

Stereocorder

SERVICE MANUAL

SONY *Model 600*

SONY

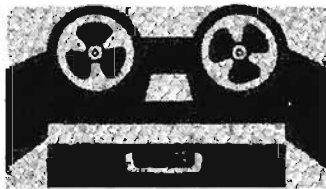

SUPERSCOPE

The Tapeway to Stereo

AUDIO ELECTRONICS DIVISION

8150 VINELAND AVENUE, SUN VALLEY, CALIFORNIA

SONY STERECORDER MODEL 600

Stereophonic Magnetic Tape Recorder

SERVICE MANUAL

Table of Contents

Section 1	SPECIFICATIONS
Section 2	ELECTRONIC ALIGNMENT PROCEDURE
2.1	Test Equipment Requirements
2.2	General Precautions
2.3	Alignment
2.3.1	Head Demagnetization
2.3.2	Head Alignment
2.3.3	Bias Adjustment
2.3.4	Playback Meter Calibration
2.3.5	Record Meter Calibration
2.3.6	Bias Trap Adjustment
2.3.7	Playback Frequency Response
2.3.8	Record Frequency Response

Section 3 MECHANICAL DISASSEMBLY PROCEDURE

3.1 Removal of Chassis from Case

3.2 Removal of Top Panel

3.3 Removal of Control Panel

3.4 Removal of Chassis Cage

3.5 Removal of Capstan Sleeve and Pinch Roller

3.6 Removal of Flywheel

3.7 Removal of Feed and Take-up Reel Spindles

3.8 Removal of Take-up, Rewind and Drive Pucks

3.9 Removal of Hysteresis Motor

3.10 Removal of V. U. Meters

3.11 Removal of Tape Counter

3.12 Removal of Automatic Cut-off Switch Assembly

3.13 Removal of Erase Record or Playback Heads

3.14 Removal of Record Pilot Lights

3.15 Removal of Instant Stop Lever Assembly

3.16 Removal of Take-up Brake Arm

3.17 Disassembly of Forward/Stop/Rewind Cam Assembly

3.18 Removal of Printed Circuit Cards

Section 4 MECHANICAL ADJUSTMENTS

4.1 Linkage from Record Buttons to Record Play Switch

*4.2 . Linkage from Forward/Stop/Play Assembly to Automatic A. C.
Cut-off Assembly*

4.3 Motor Drive Pulley

SECTION 1 - SPECIFICATIONS

The Sony Superscope STERECORDER Model 600 is a two-speed, two-channel, 1/4" magnetic tape recorder, capable of simultaneously recording or reproducing four-track tapes.

The Model 600 contains two channels of playback pre-amplification, two recording amplifiers, one push-pull bias oscillator, and a common power supply.

The recording amplifier contains a transistorized single stage microphone pre-amplifier which can also be used as a magnetic phono cartridge pre-amplifier. A two-stage transistorized playback pre-amplifier is used in each playback channel. The remaining electronics use vacuum tubes.

Separate cathode follower stages are provided in each channel for the following functions: V. U. meter drive, line output and binaural monitor. Four bias traps are incorporated in the output electronics.

Heads are 1/4 track inline (stacked) and are permanently connected to their respective amplifiers. V. U. meter indications may be obtained from either recording amplifier or playback amplifier. Drive is accomplished by hysteresis synchronous motor.

TAPE SPEED

7-1/2" per second
3-3/4" per second

FREQUENCY RESPONSE (Overall)

Each channel measured at line output jacks:

<u>SPEED</u>	<u>RESPONSE</u>
7-1/2	± 2db 50 to 15,000 cycles

SIGNAL TO NOISE RATIO

<u>Speed</u>	<u>Max. Record Level to Unweighted Noise</u>	<u>Peak Record Level to Unweighted Noise</u>
7-1/2	55 db	45 db
3-3/4	50 db	40 db

The peak record level is defined as that level at which the overall (input to output on "line jack") total RMS harmonic distortion does not exceed 1% when measured on a 400 cycle tone.

SECTION 1 - SPECIFICATIONS

Noise is measured by playing an erased portion of the tape, on which a signal of peak recording level was present prior to erasure. This will produce the overall figure of noise, including the bias and erase noise, as well as the record and playback amplifier noise.

FLUTTER AND WOW

<u>Speed</u>	<u>Flutter and Wow</u>
7-1/2	Less than 0.17% RMS
3-3/4	Less than 0.25% RMS

The flutter and wow measurements include all components between 0 and 250 c/s.

PLAYING TIME WITH 7-1/2" REEL (1,200 feet of tape)

<u>Speed</u>	<u>Playing Time</u>	<u>Timing Accuracy</u>
7-1/2	32 minutes	0.3%
3-3/4	64 minutes	0.3%

OPERATION OF CONTROLS

DRIVE MECHANISM CONTROLS

All controls for complete operation of tape drive mechanism and speed selection are located in the upper control panel.

FORWARD/STOP/REWIND SELECTOR

This three-position selector is controlled by the large grey knob located on the right side of the upper control panel. FORWARD/STOP/REWIND functions are indicated in raised letters directly below the knob.

TO OPERATE

For FORWARD function turn the knob CLOCKWISE.

For REWIND function turn the knob COUNTER CLOCKWISE.

NOTE: Selection of FORWARD or REWIND must be made from CENTER or STOP position of the knob.

Do not change from FORWARD to REWIND (or vice versa) until tape comes to a complete stop.

SECTION 1 - SPECIFICATIONSFAST FORWARD LEVER

Fast forward selection is controlled by the chrome plated spring loaded lever located at the immediate left of the FORWARD/STOP/REWIND Selector Knob. It is indicated in black letters "FAST FORWARD" with a small black arrow pointing upward. The FAST FORWARD LEVER operates in both 3-3/4 and 7-1/2 ips.

TO OPERATE

After STERECORDER 600 is placed in normal forward motion at either speed, push FAST FORWARD LEVER upwards with a smooth quick movement until lever clicks into position then release lever. To stop FAST FORWARD motion, turn the FORWARD/STOP/REWIND Selector Knob to STOP position.

INSTANT STOP LEVER

This control is the plastic capped lever located on the left of the upper control panel. It is indicated in raised letters "INSTANT STOP" with a small raised arrow pointing to the left.

When applied, this lever instantly and safely stops normal forward motion of the tape for editing and cueing. Both reels can still be rotated by hand in either direction while lever is applied.

TO OPERATE

Push lever to the left and hold until ready to release. Upon releasing the lever, the tape will immediately pick up full forward speed.

NOTE: Do not apply INSTANT STOP while STERECORDER 600 is in FAST FORWARD or REWIND position.

AUTOMATIC SHUT-OFF SWITCH

This switch is controlled by the wire lever located between the tape guide and erase head inside the Head Cover. In STOP position, the shut-off lever recedes into a slot to facilitate easy tape threading. After tape is threaded and the mechanism is placed in FORWARD motion, the shut-off lever automatically raises and rests against the tape. When the tape runs off the feed reel, the lever will activate a micro switch and shut off the recorder.

TAPE SPEED SELECTOR

Speed selection is controlled by the small silver knob located in the center of the upper control panel directly behind the head cover. This knob

SECTION 1 - SPECIFICATIONS

selects the desired speeds of either 3-3/4 ips or 7-1/2 ips, and automatically sets the proper recording and playback characteristics for each speed.

TO OPERATE

Your STERECORDER 600 is shipped with the TAPE SPEED SELECTOR in 3-3/4 ips position. To change from 3-3/4 ips to 7-1/2 ips, press down SPEED SELECTOR KNOB and turn clockwise to 7-1/2 ips position.

NOTE: (Do not turn SPEED SELECTOR KNOB CLOCKWISE from 3-3/4 ips to 7-1/2 ips without first pressing knob down). To change from 7-1/2 ips to 3-3/4 ips, simply turn SPEED SELECTOR KNOB counter-clockwise from 7-1/2 ips position to 3-3/4 ips position and allow knob to raise upwards.

NOTE: DO NOT CHANGE SPEED WHILE TAPE IS IN MOTION.

TAPE COUNTER

A 3-digit numerical indicator is located at the left of the upper control panel. It is activated through a worm gear mechanism by a belt connected to the feed reel.

TO OPERATE

Press white button, three zeros will appear in the window.

ELECTRONIC CONTROLS

All controls for complete operation of recording amplifiers, playback pre-amplifiers and monitor amplifiers, are located on the lower front control panel of the STERECORDER.

ON/OFF SWITCH

Located at the extreme left of the lower panel and operated by the grey push button marked "AC-ON/OFF".

TO OPERATE

Push button down and release to turn recorder ON or OFF.

RECORD SELECTORS

The two coral push-buttons located on the left of the lower panel and marked respectively "CH. 1 and CH. 2" select either stereophonic (both) or monophonic (either) recording modes. Each push-button instantly selects the desired mode of recording.

SECTION 1 - SPECIFICATIONS

TO OPERATE

Press the desired record button and hold down as the STERECORDER 600 is placed into the forward mode. Pre-setting of recording level does not require the use of the record button.

NOTE: The record buttons are equipped with a mechanical safety interlock to prevent accidental erasure of previously recorded tapes. The "RECORD" buttons can only be depressed while the mechanism is in the "STOP" position.

INPUT VOLUME

Each recording channel is equipped with 2 level controls to increase or decrease recording levels. These controls are operated by the round knobs mounted coaxially at the left center of the lower control panel. They are designated respectively MICROPHONE and LINE. The lower knobs are used for CH-2, the upper CH-1.

NOTE: The feature of separate level controls for microphone and auxiliary inputs provide the facilities to mix "live" microphone recording simultaneously with recordings made from stereo tuners, stereo discs, or any other auxiliary source.

OUTPUT VOLUME

Each playback channel is equipped with 2 level controls to increase or decrease "MONITOR and LINE" output levels. These controls are operated by the round knobs mounted coaxially at the right center of the lower control panel. They are designated respectively monitor and line.

The lower knob on each pair controls the playback level of Channel 2. The upper knob on each controls Channel 1.

MONITOR SWITCHES

Separate monitor switches are provided for each channel. They are marked Channel 1 and Channel 2. Two positions "SOURCE and TAPE" are indicated: In the tape position, monitoring is accomplished from tape through the playback amplifiers; in source, the signal is derived from the recording amplifiers.

Recording levels may be pre-set without depressing the record button. Simply place the monitor switch in the source position and adjust the appropriate input volume control for the desired level.

LINE OUTPUT

Both line outputs are simultaneously controlled by a ganged switch. When placed in the off position, the switch will have no effect unless the

SECTION 1 - SPECIFICATIONS

STERECORDER 600 is placed in the record mode. At such time, the output for the channel which is recording will be muted, the other channel will function normally.

V. U. METERS

Two V. U. meters are provided with the STERECORDER 600 for extremely accurate recording and playback level indication.

These meters are calibrated to NAB standards to allow the maximum recording level without distortion. For best recording results, the level controls should be adjusted so that the deflection of the V. U. indicator needle does not exceed 100%.

It is normal for transient peaks to occasionally deflect the needle into the red zone; however, the level should be lowered slightly if these peaks cause the needle to hit against the stop pin beyond the red zone.

RECORD INDICATOR LIGHTS

Two red pilot lights are provided to indicate when the STERECORDER 600 is in recording mode.

Located directly above the V. U. meters, the left light indicates CH. 1 and the right light indicates CH. 2. In stereo recording mode both lights will glow, while in monophonic recording mode either CH. 1 or CH. 2, depending upon channel in use, will glow.

INPUT AND OUTPUT CONNECTIONS

All input and output facilities, with the exception of microphone inputs and binaural monitor, are located on the rear of STERECORDER 600 chassis.

MICROPHONE INPUTS

There are 2 microphone inputs located at the lower left of the lower front panel and indicated "MICROPHONE". Channel 1 and Channel 2 are indicated respectively on the left and right of each input. These input jacks are of the "Mini-jack" variety and accept the standard 5/8" tip "Mini" type plug. The microphone input impedance is engineered for the Sony F-86, F-87, or F-96 Microphone or any high quality dynamic microphone of 600 ohm impedance.

BINAURAL MONITOR

The binaural monitor jack is designed for the Sony Model DR1-C binaural headset. It can be used with any high impedance, 10k ohm or more, binaural headset equipped with a standard binaural phone plug. The volume of this output is controlled by the monitor volume control.

SECTION 1 - SPECIFICATIONS

AUXILIARY INPUTS

The two auxiliary inputs are located on the upper left rear of the chassis, and designated "AUX. INPUT".

These inputs serve a dual function, they may be used for recording from high level sources, such as pre-amps, AM/FM tuners, TV, or tape recorders with built-in playback pre-amplifiers. However, by placing the slide switch marked "MAGNETIC PHONO/MIKE" in the magnetic phono position, a magnetic phono cartridge may be connected directly to the auxiliary inputs. It is not possible to use the magnetic phono and mike inputs simultaneously, nor can a tape playback head output, such as Sony 262-D or 263-D, be connected directly to these inputs.

LINE OUTPUTS

The 2 Line Outputs are located on the center left rear of the chassis, and are designated "LINE OUT".

These outputs are high level 600 ohm impedance and are used to connect the STERECORDER 600 to external pre-amplifiers and amplifiers.

PROPER CONNECTION FOR EXTERNAL AMPLIFICATION

It is important when using external pre-amplifiers and power amplifiers from LINE OUTPUTS that the playback level controls of the STERECORDER 600 be properly adjusted. It is recommended that these level controls be adjusted at a point below the Number 7 on the dial calibration. Control of volume can then be accomplished with the volume controls of the external pre-amplifiers. Keeping the output level of the STERECORDER 600 relatively low avoids the possibility of overloading the input of the external pre-amplifier, thereby avoiding distortion and hum.

AC RECEPTACLES

There are 3 AC receptacles located on the rear of the chassis. The upper round receptacle is for connection of the main power cord to the STERECORDER 600.

The other 2 rectangular receptacles below the main power receptacle are for convenient power connection of other components. The left receptacle is a direct 117 volt connector and is "hot" even though the power switch to the STERECORDER 600 is off.

The right receptacle is operative only when the power switch and automatic shut-off switch of STERECORDER 600 are "ON".

SECTION 1 - SPECIFICATIONS

POWER REQUIREMENTS

The Model 600 STERECORDER operates from 117 volts AC. The standard model operates on 60 c/s supply.

The power consumption is approximately 80 watts.

SECTION 2 - ALIGNMENT PROCEDURE

After a major repair or head replacement has been made, it is recommended that a complete checkout of the STERECORDER be performed. In this section, the general procedure for checking and aligning the STERECORDER Model 600 is outlined.

The alignment has to be performed only at 7-1/2 ips. The performance at 3-3/4 ips will meet the specifications if the machine operates normally at 7-1/2 ips.

- 2.1 Alignment and test equipment requirements for proper alignment and testing:
- a. Audio Oscillator - Hewlett-Packard Model 200CD or equivalent.
 - b. Vacuum Tube Voltmeter - Hewlett-Packard Model 400D or equivalent.
 - c. Head Demagnetizer.
 - d. Alignment Tape - Ampex Catalog #31321-04 or equivalent. *

- 2.2 General Precautions:
- a. It is always advisable to demagnetize the Recording and Playback heads BEFORE putting an alignment tape on the STERECORDER. Magnetization of the heads will cause partial erasure of the high frequencies on the tape and therefore make it useless as a standard. Demagnetization procedure is given under Paragraph 2.3.1.
 - b. The output of the STERECORDER must always be properly terminated when testing or aligning. The output impedance of the STERECORDER should be terminated in 200k to 1.0 meg ohms.
 - c. Never leave the right-hand knob in FORWARD position after the AC power is off.
 - d. Never change speeds while the mechanism is in FORWARD motion.
 - e. Demagnetize all metal tools which will be used to repair or adjust instrument.

2.3 Alignment:

2.3.1. Head Demagnetization

Before threading the alignment tape, the Recording and Playback heads must be demagnetized. During use, the heads may occasionally become permanently magnetized by allowing the heads to come into contact with a magnetized object. Magnetized heads will cause considerable increase in the noise level and may ruin good tapes by partially erasing the high frequencies. The following precautions are recommended to avoid head magnetization:

* A suitable playback alignment tape is available from Superscope, Inc., at a cost of \$7.50.

SECTION 2 - ALIGNMENT PROCEDURE

- a. Do not remove any tubes from the amplifier while the STERECORDER is operating in REC. mode.
- b. Do not connect or disconnect input leads while recording.
- c. Do not test continuity of the heads with an ohmeter.
- d. Do not saturate the RECORD amplifier with abnormally high input signals.

Whenever necessary, the following demagnetization procedure can be performed:

With the STERECORDER switched off, the REWIND/STOP/FORWARD knob in STOP position, plug a demagnetizer into an AC main outlet. Bring the tips of the demagnetizer into close proximity to - but not in contact with - the head core stacks. Run the tips of the demagnetizer up and down the entire length of the core stack three or four times. The tips of the demagnetizer should straddle the gaps. Remove the demagnetizer VERY SLOWLY, allowing the influence of its AC field to die off gradually. In case demagnetization is not effected, repeat process.

2.3.2. Head Alignment

- a. Elevation alignment - there are facilities for the vertical adjustment of the head in relation to the tape. The exact vertical position of the head is adjusted at the factory and should never need adjustment. However, should a head be replaced, it is necessary to check the head height. Thread a tape on the instrument and observe that during tape motion, the tape is approximately .0015" (1.5 mils) above the top edge of the upper head core of both record and play heads, and .0015" (1.5 mils) below the top edge of the upper head core of the erase head. If the tape fails to track within these limits, poor erasure, cross-talk or unbalance in the output may result. Correction for tracking error is accomplished by the adjustment of the two tape guides located to the right and left of the head assembly. Mis-alignment of individual heads can be corrected by the four screws at the head mounting base.
- b. Playback azimuth alignment - the azimuth alignment screw is located on the right side of the play head. It also serves to secure the head. Thread an alignment tape on the STERECORDER 600, adjust volume controls, monitor on tape, for an indication on the V. U. meters. During playback of the 10kc tone, adjust the azimuth alignment for maximum indication on the V. U. meters, reduce gain if necessary to maintain meter indication below full scale.

SECTION 2 - ALIGNMENT PROCEDURE

- c. Record azimuth alignment - place a reel of tape on the machine and connect an oscillator (10kc) to the auxiliary inputs. Adjust line volume control for an indication of -10db with the monitor switch in the source position. Record the 10kc signal on both channels and switch monitor to the tape position; adjust the azimuth alignment screw of the record head for maximum output; note the slight time delay due to head spacing.

2.3.3. Bias Adjustment

With the same test conditions as record azimuth alignment, record a 1kc tone on the tape at "0" level. Monitoring Channel 1 adjust potentiometer on left side of recorder nearest the back for maximum indication on the meter, turn clockwise until level drops 1/2db. Repeat for Channel 2, using the front control.

Note: Small variations in bias levels will have major effects in very high frequency response. To obtain the most uniform response, it is necessary to adjust the Record Equalization controls, R127, R227, L102, L202. These adjustments are covered in Section 2.3.8.

2.3.4. Playback Meter Calibration

Place an Ampex alignment tape on the recorder, switch meters to "tape" position and connect an AC VTVM to the line output jacks. Adjust the line volume control to the maximum clockwise position. The normal operating level section of the tape should give a 6db reading on the VTVM; if not, adjust R140, CH. 1, and R240, CH. 2, for the correct indication. Do not adjust LINE VOLUME controls. The V. U. meters should read "0" for a line output of 6db. If they do not, adjust R144, CH. 1, R244, CH. 2, for the correct indication.

2.3.5. Record Meter Calibration

Place a blank tape on the Model 600; connect an audio oscillator, 1kc 1 volt, to the line input; meter selector to "tape"; place Model 600 in Record mode. Adjust Line Input controls for "0" indication on meters; switch meters to "source"; adjust R120, CH-1, R220, CH-2, for a meter indication of "0" db.

2.3.6. Bias Trap Adjustment

Place the Model 600 in Record and defeat the automatic shutoff. Connect a VTVM to Line Output and place Line Output controls to maximum. Adjust L102, L103 - CH-1, L202, L203 - CH-2, for minimum meter indication.

SECTION 2 - ALIGNMENT PROCEDURE

2.3.7. Playback Frequency Response

NOTE: Before making a frequency response test, be sure the alignment of the head is correct. Set VTVM on +0db range and, using the second signal on the alignment tape (250 cps recorded at maximum signal), adjust each of the individual volume controls, until a reading of +0db on the VTVM scale is obtained on both channels. Mark the volume control settings for this reading and do not touch these controls until all the adjustments are made.

The next tone in the alignment tape is a reference tone, recorded at -10db. Set the VTVM to the -10db range. The reading will be again 0db on the VTVM scale.

Following this tone, there is a sequence of tones for frequency response check: 7-1/2 Equalization Adjust: Play 10kc. Adjust equalization for -10db at 10kc. Equalization pot is 2nd from top - Board #3. Tolerance is ± 2 db at 10kc. 3-3/4 Equalization Adjust: Play 5kc. Adjust equalization for -10db. Pot is on the top of the board. Tolerance is ± 2 db at 5kc.

2.3.8. Record - Playback Frequency Response

Thread a new tape on the machine. Record several frequencies from 15k cps to 50 cps, maintaining the input voltage constant at 7-1/2 ips. Play back these frequencies. The response, provided the bias adjustment is correct, will fall within the range of ± 2 db from a reference level taken at 250 cps. It is useful to remember that excessive bias current will cause the high frequency end to drop off. Refer to Section 2.3.3. Adjust R127, R227 to zero; L102, L202 for most uniform response 10kc-15kc.

Note 1 - Due to the nature of the pre-emphasis in the record circuit, tape saturation will occur at the high frequencies unless the response check is made at least 10db below normal operating level. The input signal, therefore, must be 10db lower than the one that gives a reading of 100% on the meters when the machine is in RECORD mode.

If not satisfactory, peak L101 at 15kc and recheck at 10kc and 15kc. Response at 15kc may be -2 db ± 7 db. If the response at 15kc is too high relative to 10kc, tune the slug to a higher frequency (16 - 18kc) and recheck. If the response at 10kc is too high, increase the bias to 1db below peak, same direction, and recheck. Repeat slug at 15kc if necessary.

SECTION 2 - ALIGNMENT PROCEDURE

2.3.9. Overall Noise Measurements

The overall noise is measured by finding the ratio between the signal level that gives a total harmonic distortion of 3% at 400 cps and the noise obtained when a tape recorded at 400 cps peak level is erased on the recorder and played back on the same recorder.

Note: The 3% THD level corresponds to approximately 6db above the peak recording level.

Note: When performing noise measurements, be certain that the heads are clean and demagnetized.

2.4.0. Distortion Measurements

Overall harmonic distortion can be measured by using any standard distortion measurement apparatus across the output. The readings from a wave analyser or selective frequency distortion meter will be more accurate than those from a null type instrument at lower distortion levels. Distortion readings are somewhat dependent on tape. A reading of less than 1.5% should be obtained on overall test with the maximum operating level recorded on the tape and the volume controls set to approximately 0-db output.

2.4.1. Flutter and Wow Measurements

Flutter and wow are produced by periodic irregularities in tape speed and appear as cyclic frequency deviations in recording or reproduction. They can be measured by means of any standard wow and flutter bridge. Note that variations in amplitude, as noticed sometimes on level measurements, do not constitute wow or flutter and are entirely due to tape coating variations. Readings on the wow and flutter bridge should be well under 0.15% for 7-1/2 ips and 0.25% for 3-3/4 ips speeds.

MODEL 600 VOLTAGE CHART

<u>Tube</u>	<u>1</u>	<u>2</u>	<u>3</u>	<u>4</u>	<u>5</u>	<u>6</u>	<u>7</u>	<u>8</u>	<u>Pin</u> <u>9</u>
V101 6AN8	168	35	38	Fil	Fil	45	70	0	5.4
V102 12AT7	100	0	.9	Fil	Fil	245	23	27	Fil
V102 12AT7	265	36	41	Fil	Fil	265	36	39	Fil
V201 6AN8	168	35	38	Fil	Fil	45	70	0	5.4
V202 12AT7	100	0	.9	Fil	Fil	245	23	27	Fil
V203 12AT7	265	36	41	Fil	Fil	265	36	39	Fil
V2 12BH7-A	248	--	0	Fil	248	--	0	Fil	Fil
V1 6CA4	AC 260		290	Fil	Fil		AC 260		

<u>Transistors</u>	<u>Emitter</u>	<u>Base</u>	<u>Collector</u>
X101-2SD64-5	2.5	2.6	10
X102-2SD64-5	2.6	2.7	5.2
X103-2SD64-4	4.9	5.2	9
X201-2SD64-5	2.5	2.6	10
X202-2SD64-5	2.6	2.7	5.2

Voltages for V2 are in Record mode.

Voltages measured with VTVM, Chassis is B-.

All voltages DC except as noted.

NOTE: Electrical parts list inside.

SYMBOL	NAME	SPECIFICATION	SYMBOL	NAME	SPECIFICATION
X ¹⁰¹ ₂₀₁	TRANSISTOR	2SD64-5	S ₁	POWER SWITCH	
X ¹⁰² ₂₀₂	"	"	S ₂	AC SHUT-OFF SWITCH	MICRO SWITCH
X ¹⁰³ ₂₀₃	"	2SD64-4	S ₃	BIAS SWITCH	LEAF TYPE
			S ¹⁰¹ ₂₀₁	CARTRIDGE/AUX. SWITCH	
V ₁	VACUUM TUBE	6CA4	S ¹⁰² ₂₀₂	REC/PB EDU. SWITCH	
V ₂	"	12BH7A	S ¹⁰³ ₂₀₃	MONITOR SWITCH	
V ¹⁰¹ ₂₀₁	"	6AN8	S ¹⁰⁴ ₂₀₄	LINE SWITCH	
V ¹⁰² ₂₀₂	"	12AT7	S ¹⁰⁵ ₂₀₅	REC/PB SWITCH	
V ¹⁰³ ₂₀₃	"	"			
M ¹⁰¹ ₂₀₁	LEVEL METER				
RE ¹⁰¹ ₂₀₁	RECTIFIER		R ₁	WIRE WOUND RESISTOR	500Ω 7P ±10%
			R ₂	"	500Ω " "
D.L	DAMMY COIL		R ₃	"	1.5KΩ 3P "
			R ₄	POTENTIOMETER	10KΩ (B)
L ¹⁰¹ ₂₀₁	EDU COIL		R ₅	CARBON RESISTOR	47KΩ RD ¹ / ₄ L ±5%
L ¹⁰² ₂₀₂	TRAP COIL		R ₆	"	47KΩ " "
L ¹⁰³ ₂₀₃	"		R ₇	"	47KΩ " "
			R ₈	"	47KΩ " "
			R ₉	"	250Ω " "
T ₁	POWER TRANSFORMER				
T ₂	BIAS OSC TRANSFORMER				
			K ¹⁰¹ ₂₀₁	CARBON RESISTOR	22KΩ RD ¹ / ₄ L ±5%
J ¹⁰¹ ₂₀₁	MIC INPUT JACK	MINI JACK	R ¹⁰² ₂₀₂	"	1.5KΩ " "
J ¹⁰² ₂₀₂	AUX "		R ¹⁰³ ₂₀₃	"	1.5KΩ " "
J ¹⁰³ ₂₀₃	LINE OUTPUT		R ¹⁰⁴ ₂₀₄	POTENTIOMETER	200KΩ (S)
J _{BM}	BINAURAL MONITOR		R ¹⁰⁵ ₂₀₅	"	250KΩ (A)
			R ¹⁰⁶ ₂₀₆	CARBON RESISTOR	22KΩ RD ¹ / ₄ L ±5%
			R ¹⁰⁷ ₂₀₇	"	220KΩ " "
			R ¹⁰⁸ ₂₀₈	"	220KΩ " "
CN ₁	AC POWER CONNECTOR		R ¹⁰⁹ ₂₀₉	"	1.5KΩ " "
CN ₂	AC CONSENT		R ¹¹⁰ ₂₁₀	"	5KΩ " "
CN ₃	"		R ¹¹¹ ₂₁₁	"	39KΩ " "
CN _{T1}	AC DEFEAT CONNECTOR		R ¹¹² ₂₁₂	"	22KΩ " "
CN _{T2}	"		R ¹¹³ ₂₁₃	"	100KΩ " "
CN _{T3}	POWER CONNECTOR		R ¹¹⁴ ₂₁₄	"	100KΩ " "
CNP ₁	SHORT PLUG		R ¹¹⁵ ₂₁₅	"	100KΩ " "
CNP ₂	"		R ¹¹⁶ ₂₁₆	COMPOSITION RESISTOR	120KΩ RC ¹ / ₄ ±10%
CNP ₃	POWER CONNECTOR		R ¹¹⁷ ₂₁₇	CARBON RESISTOR	1.2KΩ RD ¹ / ₄ L ±5%
			R ¹¹⁸ ₂₁₈	COMPOSITION RESISTOR	390KΩ RC ¹ / ₂ ±10%
			R ¹¹⁹ ₂₁₉	"	33KΩ RC ¹ / ₄ "
F	FUSE & HOLDER	2A	R ¹²⁰ ₂₂₀	"	150KΩ RC ¹ / ₂ "
			R ¹²¹ ₂₂₁	SEMI FIXED RESISTOR	250KΩ (A)
			R ¹²² ₂₂₂	COMPOSITION RESISTOR	470KΩ RC ¹ / ₂ ±10%
PL ¹⁰¹ ₂₀₁	REC PILOT LAMP	8V 150mA	R ¹²³ ₂₂₃	CARBON RESISTOR	750KΩ RD ¹ / ₄ L ±5%
PL ¹⁰² ₂₀₂	PILOT LAMP	"	R ¹²⁴ ₂₂₄	COMPOSITION RESISTOR	470KΩ RC ¹ / ₄ ±10%
			R ¹²⁵ ₂₂₅	CARBON RESISTOR	820Ω RD ¹ / ₄ L ±5%
M	MOTOR	MC-134	R ¹²⁶ ₂₂₆	"	3.7KΩ " "
			R ¹²⁷ ₂₂₇	COMPOSITION RESISTOR	390Ω RC ¹ / ₄ ±10%
			R ¹²⁸ ₂₂₈	SEMI FIXED RESISTOR	500Ω (B)
REC HEAD	RECORD HEAD	RP30-2902	R ¹²⁹ ₂₂₉	COMPOSITION RESISTOR	10KΩ RC ¹ / ₂ ±10%
PB HEAD	PLAYBACK HEAD	RP30-4202L	R ¹³⁰ ₂₃₀	CARBON RESISTOR	8.2KΩ RD ¹ / ₄ L ±5%
ERASE HEAD	ERASE HEAD	EF13-2902	R ¹³¹ ₂₃₁	"	1KΩ " "
			R ¹³² ₂₃₂	"	12KΩ " "
			R ¹³³ ₂₃₃	"	33KΩ " "

RESISTORS WITH *

MBOL	N A M E	SPECIFICATION	SYMBOL	N A M E	SPECIFICATION
R ₂₃₃	SEMI FIXED RESISTOR	10KΩ (B)	C ₂₀₁	MYLAR CAPACITOR	0.1μF 50WV ±10%
R ₂₃₄	"	5KΩ (B)	C ₂₀₂	"	0.02μF 100WV "
R ₂₃₅	CARBON RESISTOR	NOISELESS 5.6KΩ RD½L ±5%	C ₂₀₃	ELECTROLYTIC CAPACITOR	30μF 15WV
R ₂₃₆	"	NOISELESS 3.9KΩ " "	C ₂₀₄	"	100μF 6WV
R ₂₃₇	"	NOISELESS 3.3KΩ " "	C ₂₀₅	"	50μF 12WV
R ₂₃₈	"	NOISELESS 4.7KΩ " "	C ₂₀₆	"	100μF 25WV
R ₂₃₉	(DELETED)		C ₂₀₇	MYLAR CAPACITOR	0.1μF 50WV ±10%
R ₂₄₀	SEMI FIXED RESISTOR	50KΩ (B)	C ₂₀₈	ELECTROLYTIC CAPACITOR	100μF 6WV
R ₂₄₁	CARBON RESISTOR	100KΩ RD½L ±5%	C ₂₀₉	"	1μF 350WV
R ₂₄₂	"	±50Ω " "	C ₂₁₀	"	10μF "
R ₂₄₃	COMPOSITION RESISTOR	50KΩ RC½ ±10%	C ₂₁₁	MYLAR CAPACITOR	0.2μF 250WV
R ₂₄₄	SEMI FIXED RESISTOR	500KΩ (B)	C ₂₁₂	"	0.05μF 100WV ±10%
R ₂₄₅	COMPOSITION RESISTOR	470KΩ RC¼ ±10%	C ₂₁₃	MICA CAPACITOR	30PF 500WV "
R ₂₄₆	CARBON RESISTOR	18KΩ RD½L ±5%	C ₂₁₄	"	200PF " "
R ₂₄₇	"	3.3KΩ " "	C ₂₁₅	MYLAR CAPACITOR	0.001μF 100WV +
R ₂₄₈	POTENTIAL METER	100KΩ (A)	C ₂₁₆	"	0.009μF " "
R ₂₄₉	"	100KΩ " "	C ₂₁₇	"	0.015μF " "
R ₂₅₀	COMPOSITION RESISTOR	150KΩ RC¼ ±10%	C ₂₁₈	PAPER CAPACITOR	0.8μF 250WV
R ₂₅₁	"	10KΩ RC½ "	C ₂₁₉	MYLAR CAPACITOR	0.004μF 50WV ±20%
R ₂₅₂	CARBON RESISTOR	820Ω RD½L ±5%	C ₂₂₀	ELECTROLYTIC CAPACITOR	30μF 15WV
R ₂₅₃	"	10Ω " "	C ₂₂₁	"	200μF 25WV
R ₂₅₄	COMPOSITION RESISTOR	470KΩ RC¼ ±10%	C ₂₂₂	"	100μF 10WV
R ₂₅₅	"	10KΩ RC½ "	C ₂₂₃	MYLAR CAPACITOR	0.01μF 50WV ±10%
R ₂₅₆	CARBON RESISTOR	820Ω RD½L ±5%	C ₂₂₄	"	0.02μF 100WV "
R ₂₅₇	"	10KΩ " "	C ₂₂₅	ELECTROLYTIC CAPACITOR	350μF 12WV
R ₂₅₈	"	2.7KΩ " "	C ₂₂₆	MYLAR CAPACITOR	0.2μF 50WV ±20%
R ₂₅₉	SEMI FIXED RESISTOR	10KΩ (B)	C ₂₂₇	ELECTROLYTIC CAPACITOR	100μF 6WV
R ₂₆₀	CARBON RESISTOR	100KΩ RD½L ±5%	C ₂₂₈	MYLAR CAPACITOR	0.2μF 250WV ±10%
			C ₂₂₉	"	0.05μF 100WV "
			C ₂₃₀	"	0.002μF 50WV ±20%
			C ₂₃₁	"	0.02μF 100WV ±10%
			C ₂₃₂	ELECTROLYTIC CAPACITOR	5μF 150WV
			C ₂₃₃	MYLAR CAPACITOR	0.02μF 100WV ±10%
			C ₂₃₄	ELECTROLYTIC CAPACITOR	5μF 150WV
			C ₂₃₅	MYLAR CAPACITOR	0.003μF 100WV ±10%
			C ₂₃₆	"	0.003μF " "
			C ₂₃₇	ELECTROLYTIC CAPACITOR	1μF 150WV
C ₁	MP CAPACITOR	1.5-0.5μF 250V AC ±5%			
C ₂	"	0.3μF 100WV ±20%			
C ₃	ELECTROLYTIC CAPACITOR	40+40μF 350WV			
C ₄	"	40+40μF "			
C ₅	"	40μF 450WV			
C ₆	OIL PAPER CAPACITOR	0.1μF 400WV ±10%			
C ₇	ELECTROLYTIC CAPACITOR	10μF 350WV			
C ₈	MICA CAPACITOR	3000PF 1000WV			
C ₉	"	3000PF "			
C ₁₀	"	3000PF "			
C ₁₁	MP CAPACITOR	0.5μF 250WV			

IRE NOISELESS TYPE.

SECTION 3 - MECHANICAL DISASSEMBLY PROCEDURE

MECHANICAL DESIGN

The STERECORDER is composed of three major mechanical assemblies:

1. Tape transport mechanism.
2. Electronics chassis containing all controls, jacks and switching mechanisms.
3. Portable case for housing the above, together with cables and accessories.

3.1 REMOVAL OF CHASSIS FROM CASE

- A. Disconnect AC line from chassis.
- B. Remove fuse and cap.
- C. Place recorder face down on padded surface.
- D. Remove 4 screws and washers from back.
- E. Remove 2 screws and washers between handle.
- F. The chassis can now be removed from case.

3.2 REMOVAL OF TOP COVER PANEL

- A. Remove speed change knob.
- B. Remove 5 phillips head screws and plastic washers.
- C. Lift cover panel carefully.

3.3 REMOVAL OF CONTROL PANEL

- A. Remove head covers - front and rear.
NOTE: Set screws secure head covers.
- B. Remove FORWARD/STOP/REWIND knob.
- C. Remove volume control knobs.
- D. Slip off plastic button from instant stop lever, usually very tight - apply pressure.
- E. There are 4 screws holding this panel, 1 located next to play head, 2 located on the sides, underneath the panel, and 1 above record lights - remove these.

3.4 REMOVAL OF CHASSIS "CAGE"

- A. Remove bottom cover before removing sides, front cover can be removed separately.

SECTION 3 - MECHANICAL DISASSEMBLY PROCEDURE

3.5 REMOVAL OF CAPSTAN SLEEVE AND PINCH ROLLER

- A. Remove knurled screw on top of capstan (counter-clockwise).
- B. Insert thin V-shaped wedge between shaft and capstan sleeve and apply leverage to loosen sleeve from capstan shaft.
- C. Remove screw from top of pinch roller and remove (when re-assembling capstan sleeve, be certain that the tapered shaft and inner surface of capstan sleeve are absolutely free of oil, dust and grit).

3.6 REMOVAL OF FLYWHEEL

- A. Remove top cover panel.
- B. Remove control panel.
- C. Remove capstan sleeve and pinch roller.
- D. The flywheel assembly rests on 4 posts, approximately 1-1/4" high, located at the 4 corners of the base plate. Remove the 4 screws holding this base plate to the 4 posts. Disconnect the 2 springs attached to the back of the base plate.
- E. The entire assembly can now be turned vertically and the fly-wheel slipped out.

NOTE: Refer to exploded diagram, p. 29, when performing this operation. When re-assembling, replace left front screw loosely to act as a pivot against the pinch roller tension spring.

3.7 REMOVAL OF FEED AND TAKE-UP REEL SPINDLES

- A. Unscrew (counter-clockwise) slotted cap on top of each spindle.
- B. Remove drive belt from tape counter.
- C. Push take-up brake shoe to one side and remove take-up spindle.
- D. Push rewind puck to one side and remove feed spindle.

NOTE: Each respective shaft is bolted in place underneath the steel base plate.

3.8 REMOVAL OF TAKE-UP, REWIND AND DRIVE PUCKS

- A. Remove snap washers and composition washers.
- B. Push aside rewind push rods for accessibility and pucks can be slipped off. When re-assembling, make sure that brake block (Ref. 76) adjacent to rewind puck is in proper position.

3.9 REMOVAL OF HYSTERESIS MOTOR

- A. Remove top cover panel.
- B. Remove bottom chassis cover.

SECTION 3 - MECHANICAL DISASSEMBLY PROCEDURE

- C. *Remove drive puck and both rewind pucks*
- D. *Unsolder motor leads from capacitor.*
- E. *Remove 2 screws holding motor from top side of transport base plate.*

3.10 REMOVAL OF V. U. METERS

- A. *Remove top cover panel.*
- B. *Entire assembly can then be pulled back and removed. Unsolder connections if necessary.*

NOTE: *When re-assembling entire unit, and control panel is not in place, do not tighten holding screws until control panel is in place and V. U. meters are contoured properly to the front of the control panel.*

3.11 REMOVAL OF TAPE COUNTER

- A. *Remove top cover panel.*
- B. *Remove drive belt.*
- C. *Remove 2 screws holding bracket in place.*

3.12 REMOVAL OF AUTOMATIC CUT-OFF SWITCH ASSEMBLY

- A. *Unsolder leads from micro switch.*
- B. *Remove 2 screws holding assembly to front panel.*
- C. *Place mechanism in Forward mode.*
- D. *Remove micro switch.*

3.13 REMOVAL OF ERASE RECORD OR PLAYBACK HEADS

- A. *Remove head cover. Note set screws used to retain head cover.*
- B. *Unsolder leads to heads, noting connections and wiring color code.*
- C. *Remove azimuth alignment screw, right side of heads. Remove retaining screw, left side of heads.*

NOTE: *Observe location of screws and springs.*

3.14 REMOVAL OF RECORD PILOT LIGHTS

- A. *Remove front control panel and these pilot lights are readily accessible.*

3.15 REMOVAL OF INSTANT STOP LEVER ASSEMBLY

- A. *Disconnect spring.*
- B. *Remove instant stop arm. (Ref. 21)*
- C. *Remove snap washer from shaft.*

SECTION 3 - MECHANICAL DISASSEMBLY PROCEDURE

3.16 REMOVAL OF TAKE-UP BRAKE ARM

- A. Remove brake pressure spring.
- B. Lift brake arm from slot.

3.17 DISASSEMBLY OF FORWARD/STOP/REWIND CAM ASSEMBLY

This operation will probably only be needed on rare occasions. It should only be done by an experienced mechanic.

- A. Remove take-up puck (A12).
- B. Remove take-up puck arm (A18).
- C. Remove reset spring (Ref. 101).
- D. Remove U-shaped cam holding shaft from bottom.

NOTE: Please note position of different components while disassembling. This will facilitate re-assembling.

3.18 REMOVAL OF PRINTED CIRCUIT CARDS

- A. Remove "AMP" connectors - do not use pliers.
- B. Remove 2 screws and clips.
- C. Pull card to rear of recorder.
- D. Remove "AMP" connectors at front of card.

SECTION 4 - MECHANICAL ADJUSTMENT PROCEDURE

The mechanism of the Model 600 STERECORDER is so designed that there are no mechanical adjustments, such as brakes, tape tension, etc., necessary. The few mechanical adjustments which might be necessary after the transport has been disassembled and re-assembled are:

4.1 LINKAGE FROM RECORD BUTTONS TO RECORD/PLAY SWITCH (SW105, SW205)

- A. *Remove front and right side chassis cover.*
- B. *When depressing "RECORD" button, this linkage will activate the switch, changing the contacts to the position necessary for recording.*
- C. *Depress the "RECORD" button and place the mechanism in "FORWARD" position. This should hold the contacts in the necessary position.*
- D. *You may now adjust nut (Ref. 124) so that the contacts remain in the recording position after placing mechanism in "FORWARD" position and removing pressure from "RECORD" button.*

4.2 LINKAGE FROM FORWARD/STOP/PLAY ASSEMBLY TO AUTOMATIC AC CUT-OFF ASSEMBLY

- A. *Remove top cover panel.*
- B. *With transport in "STOP" position, bend wire lever so that tension lever (page 27) retracts into the opening to give enough clearance for tape threading.*

4.3 MOTOR DRIVE PULLEY (page 28)

- A. *Remove top cover panel.*
- B. *Loosen set screw on pulley and adjust so that, in 7-1/2 ips the top of the large diameter is about 1/32" above the top of the drive puck (A8), and 1/32" below the bottom of the take-up puck (A12).*



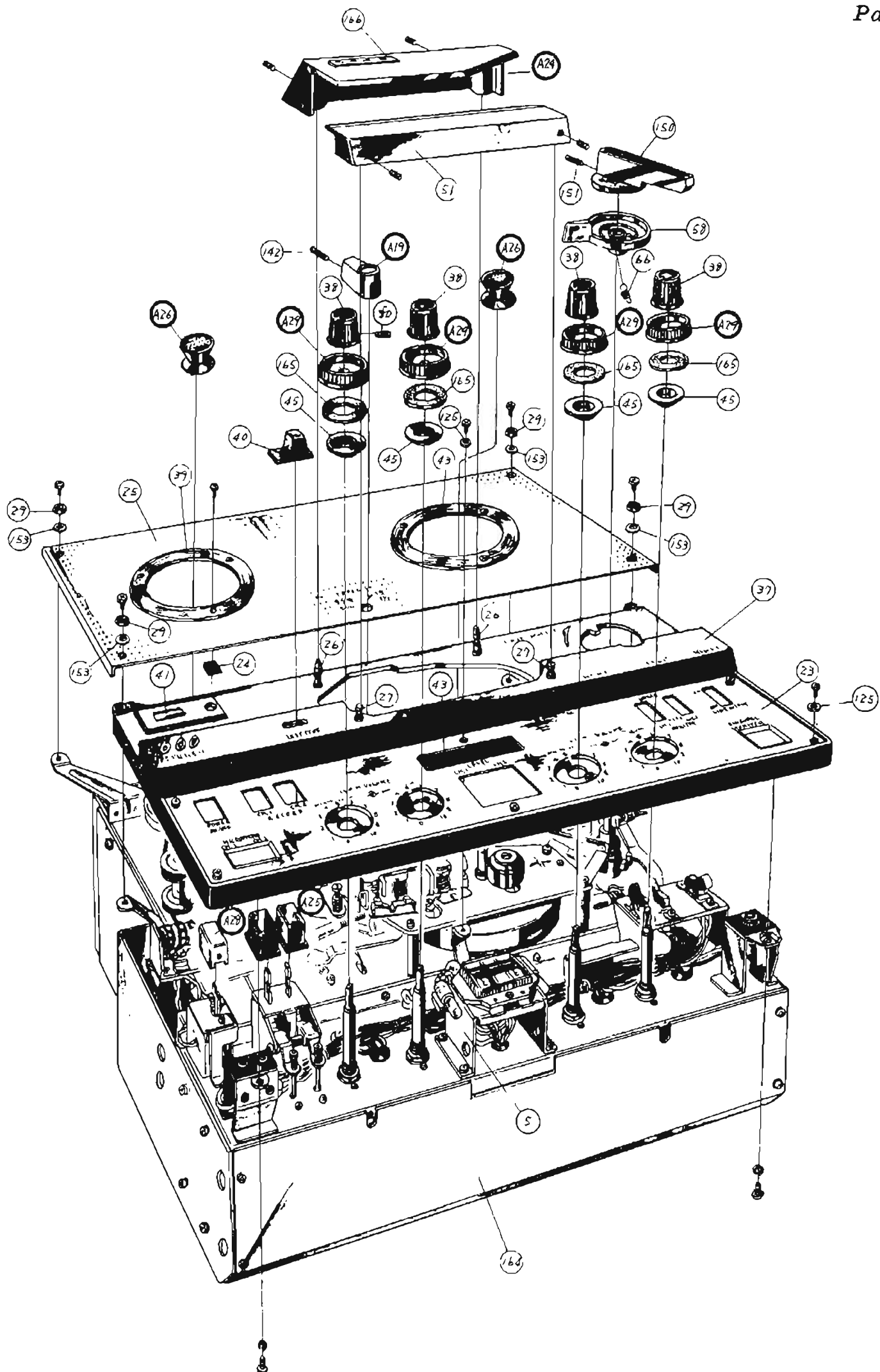

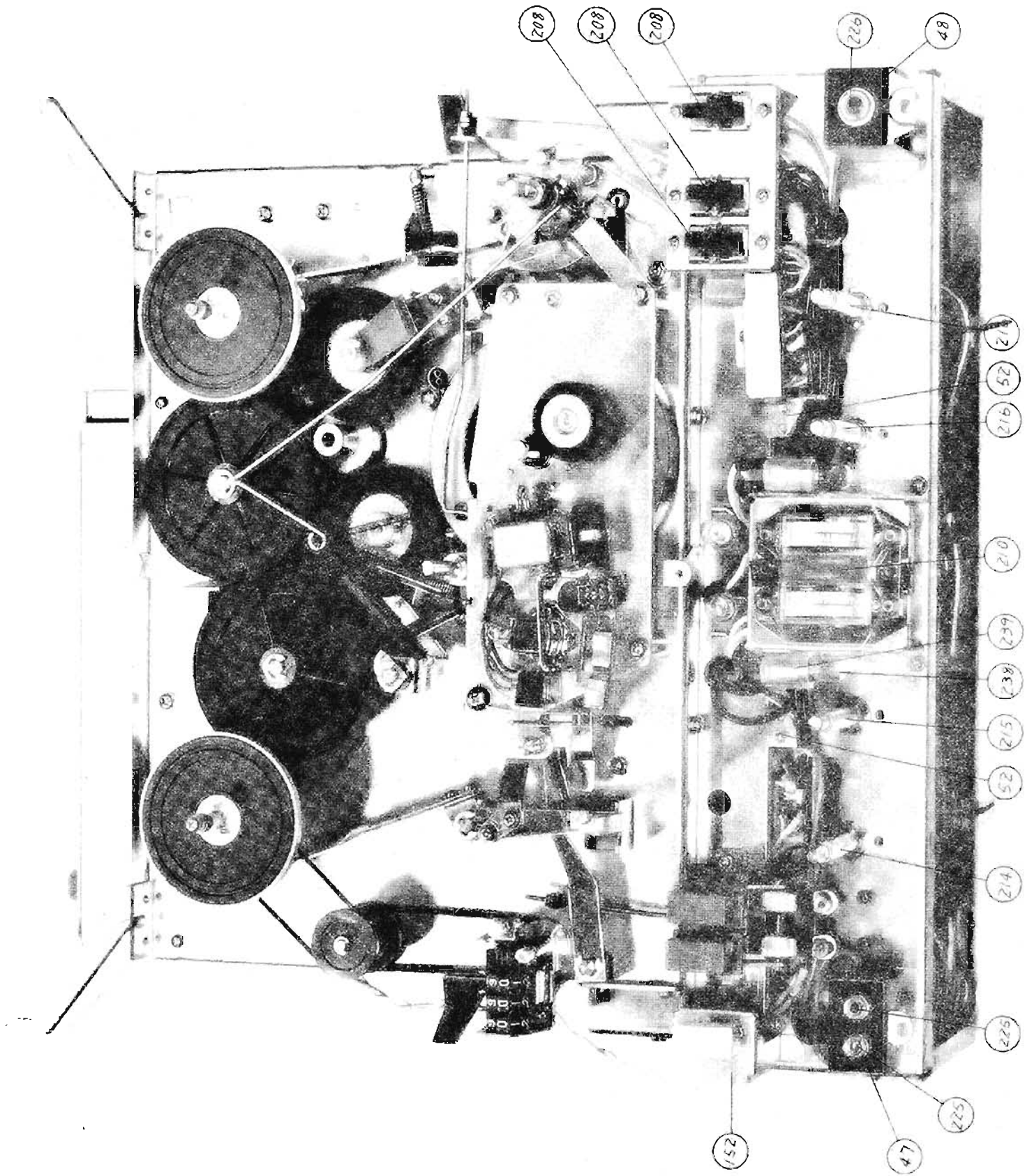

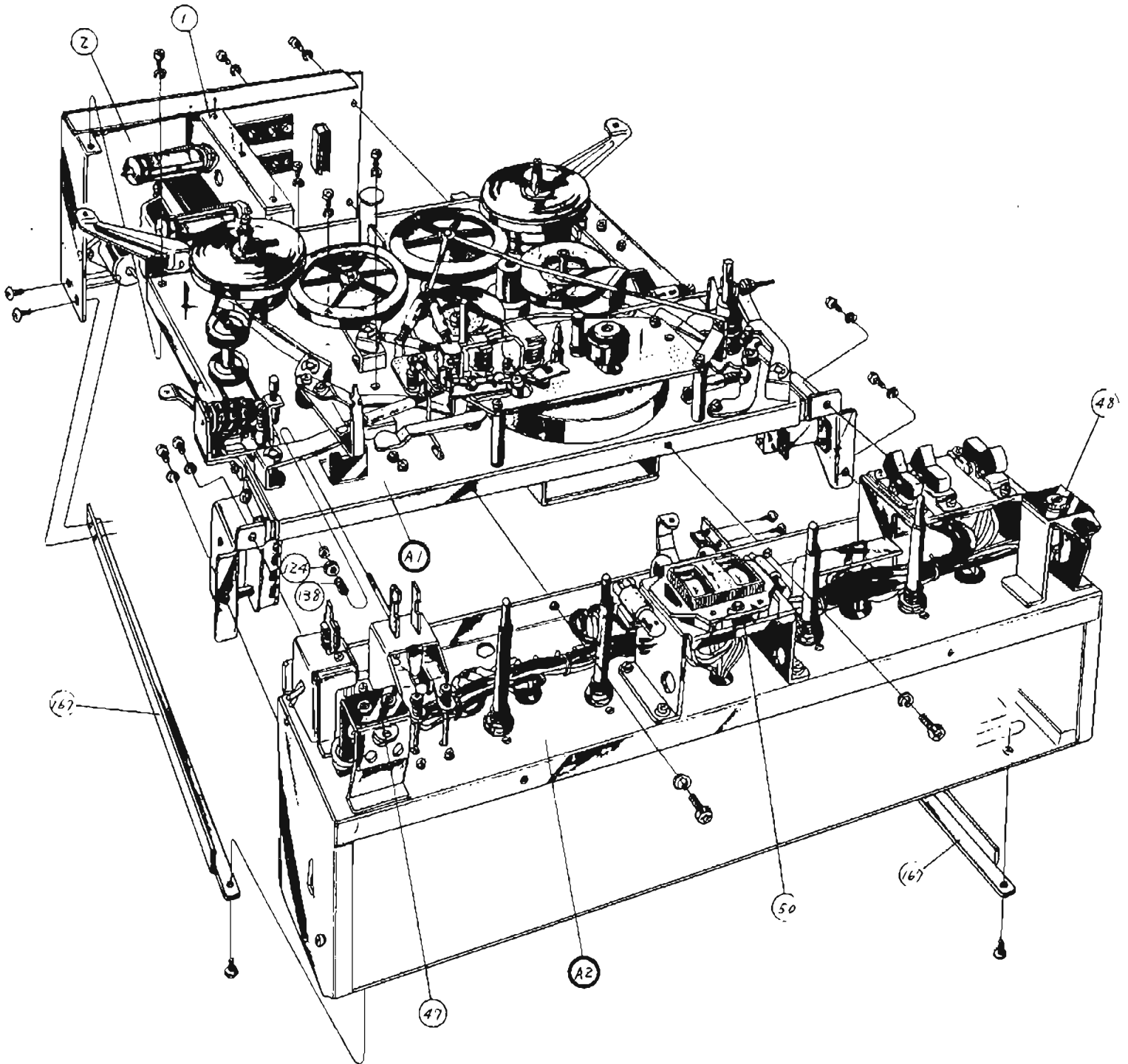

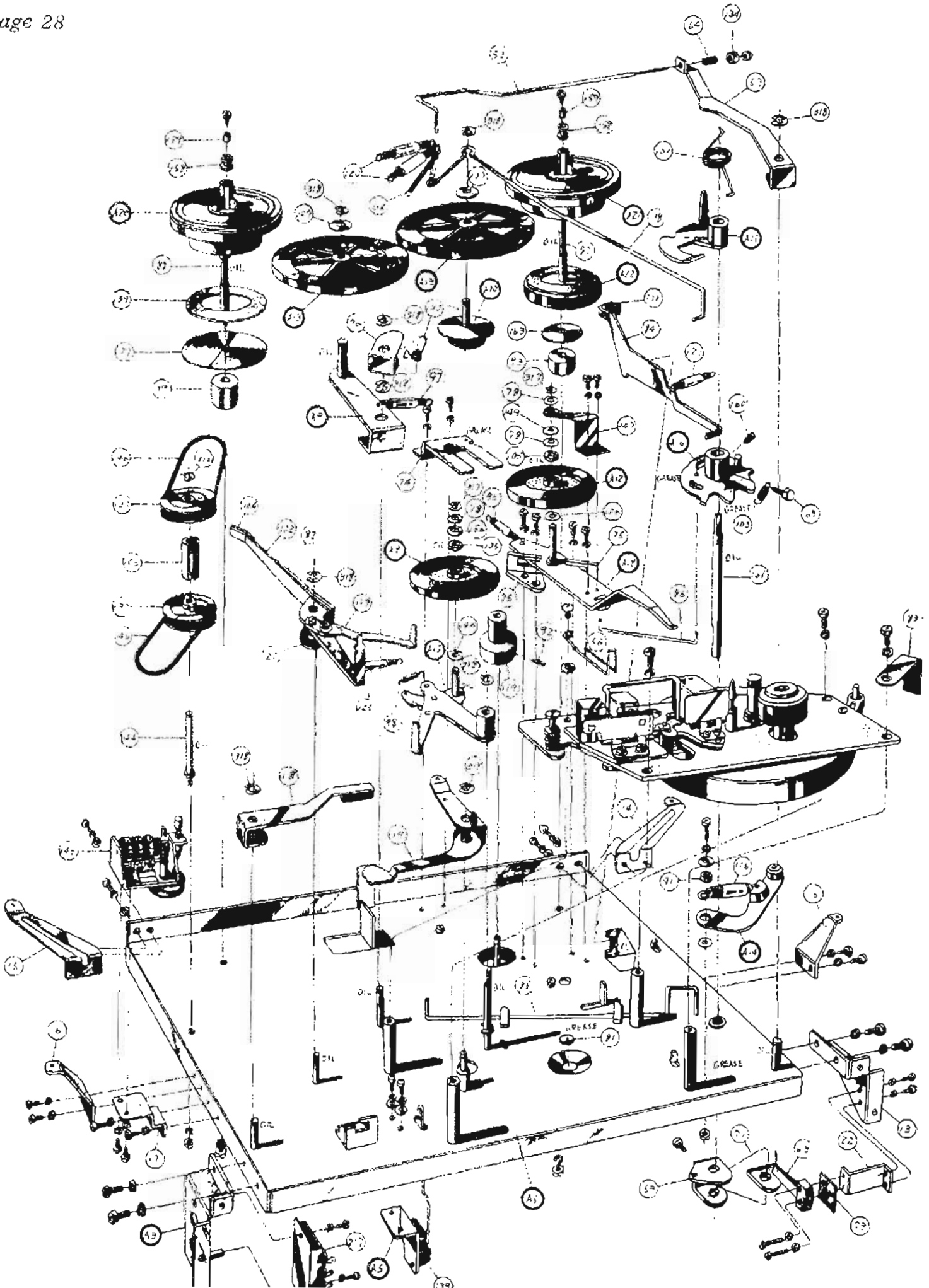

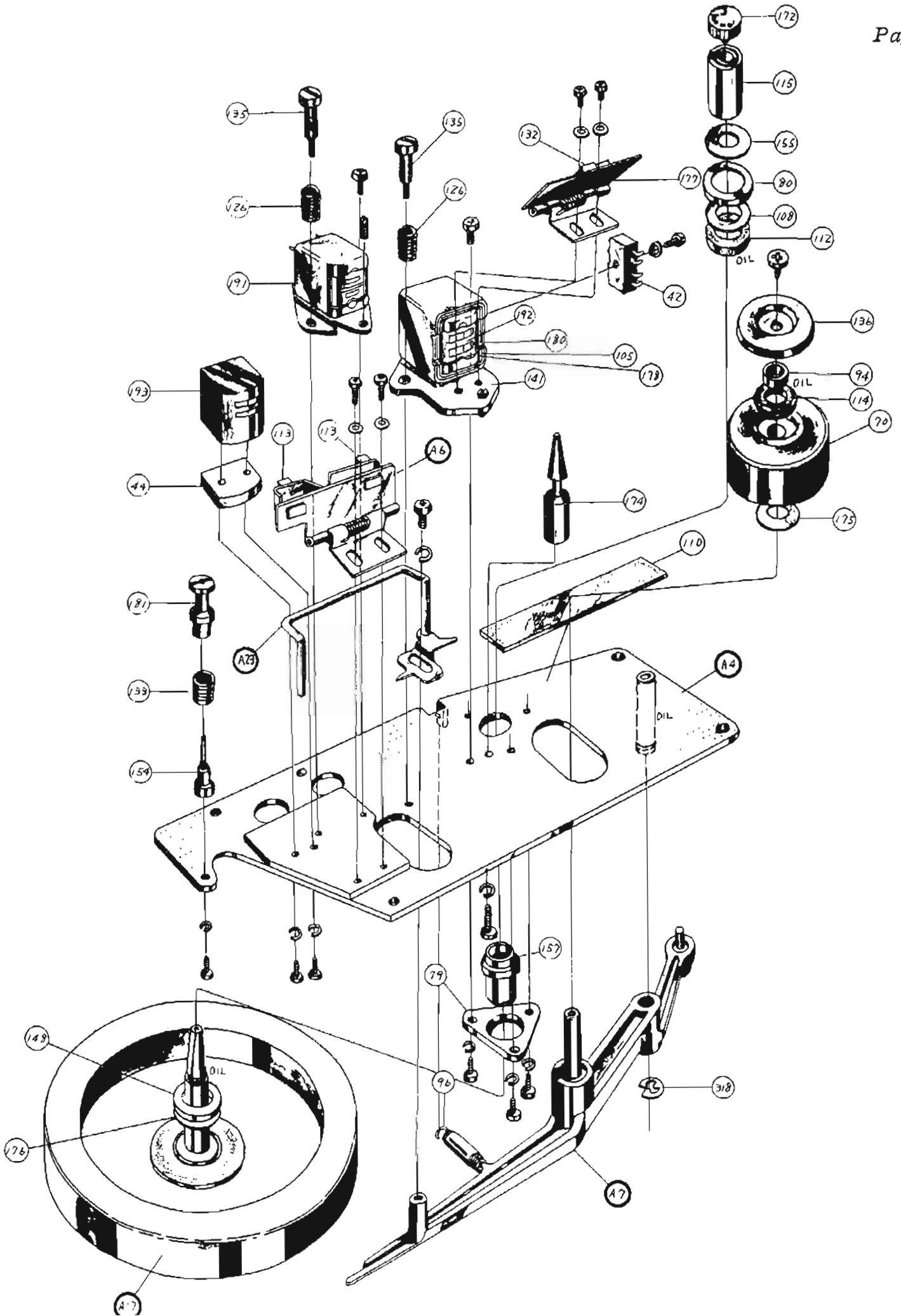

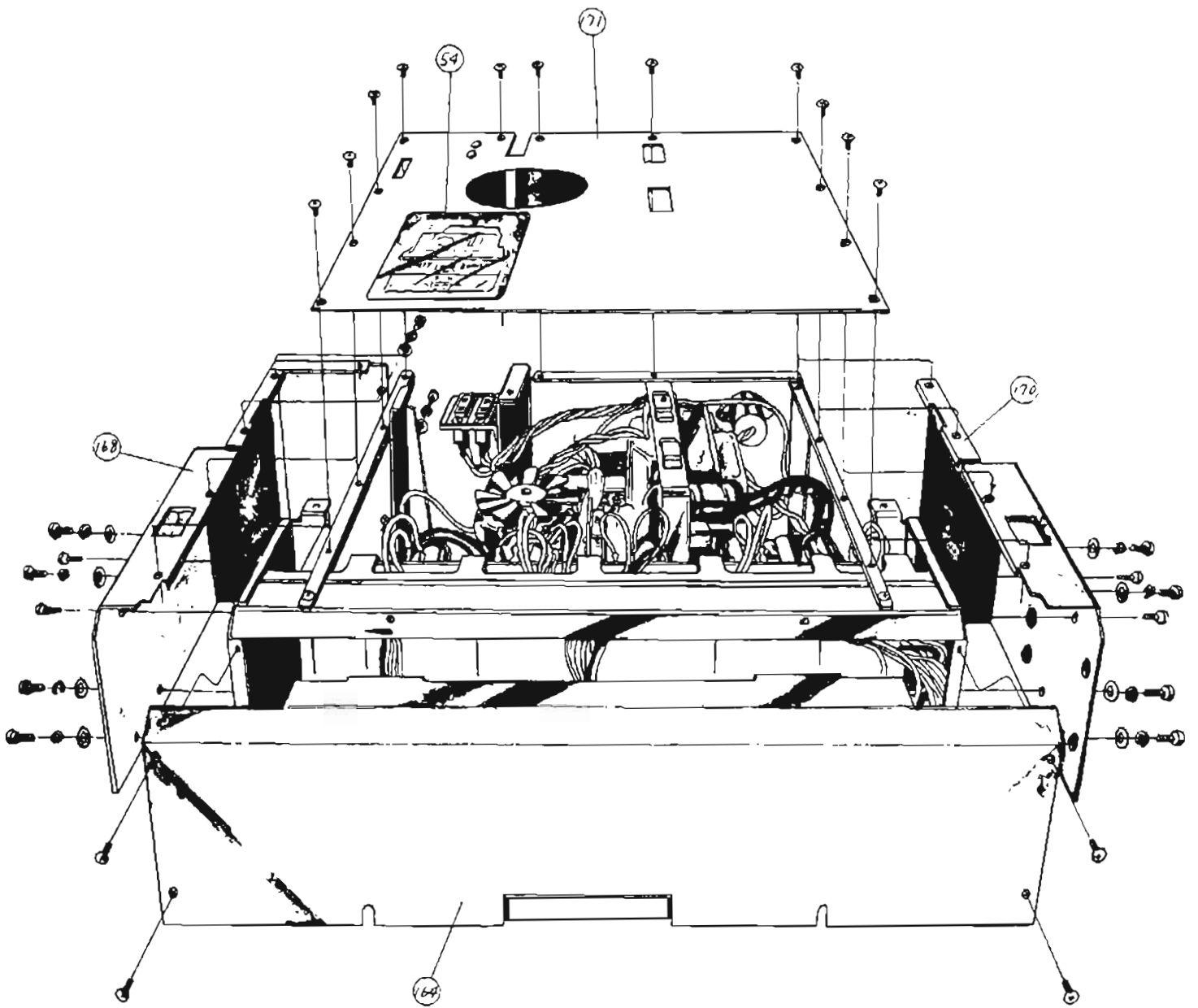

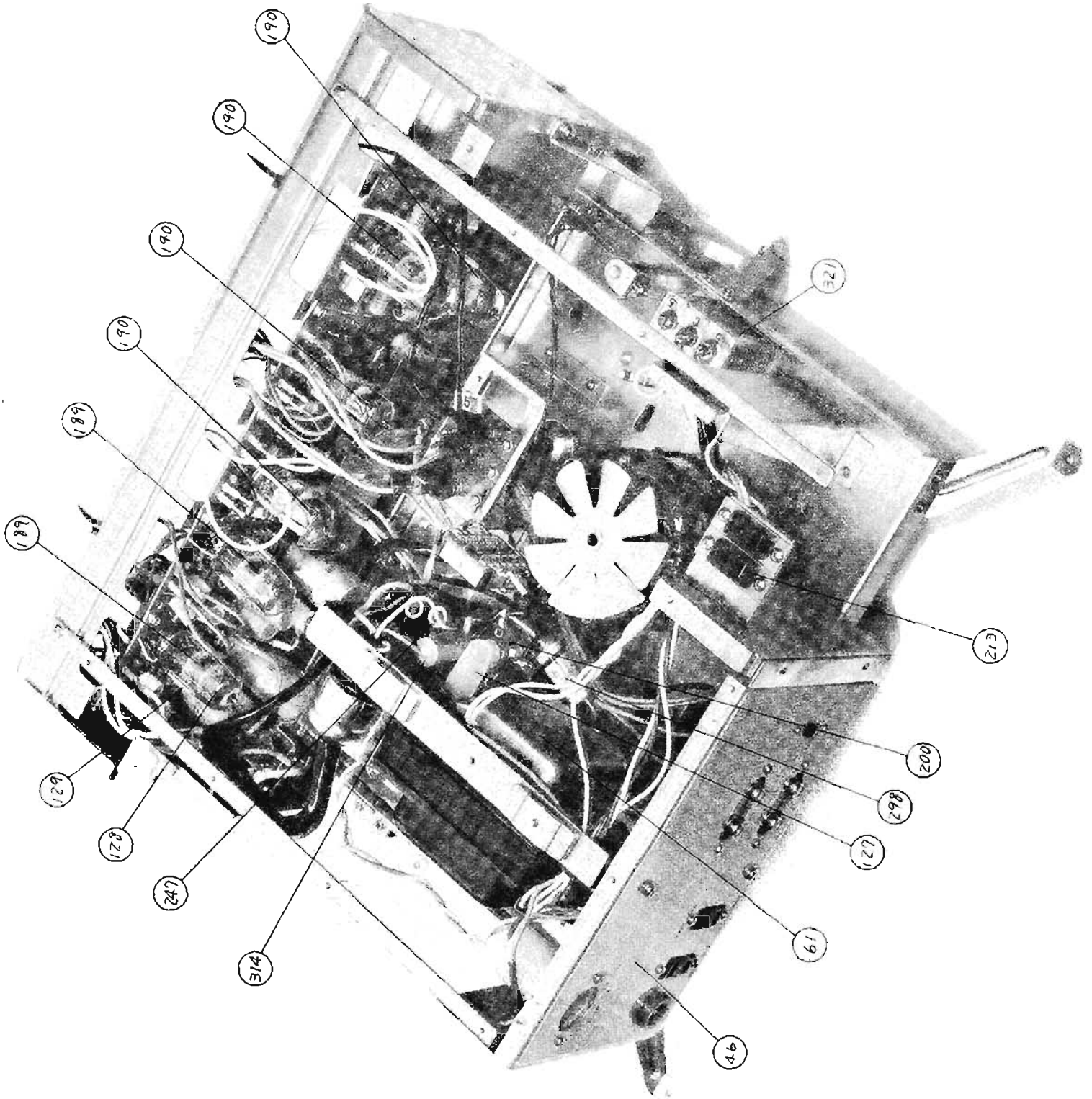

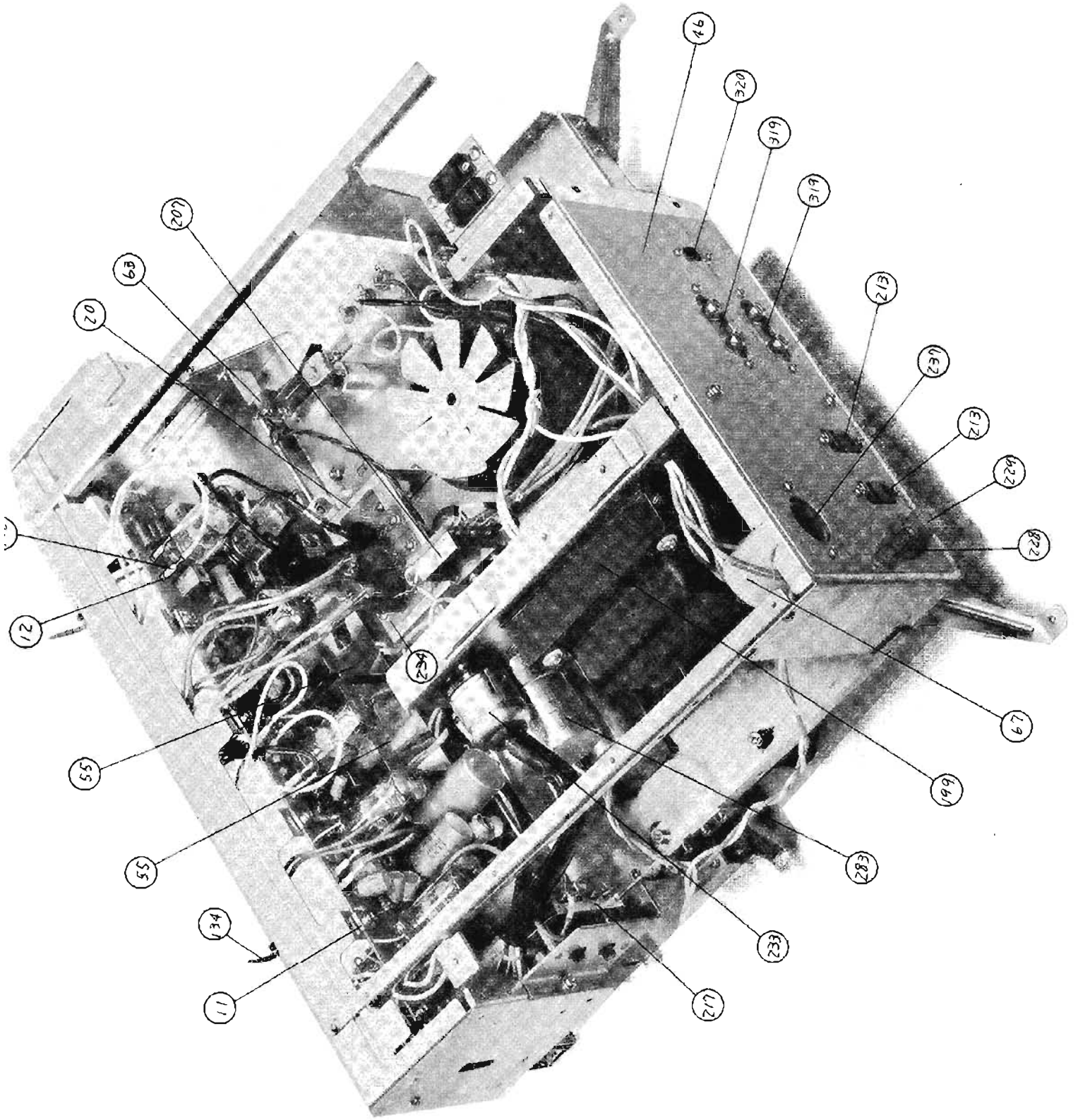

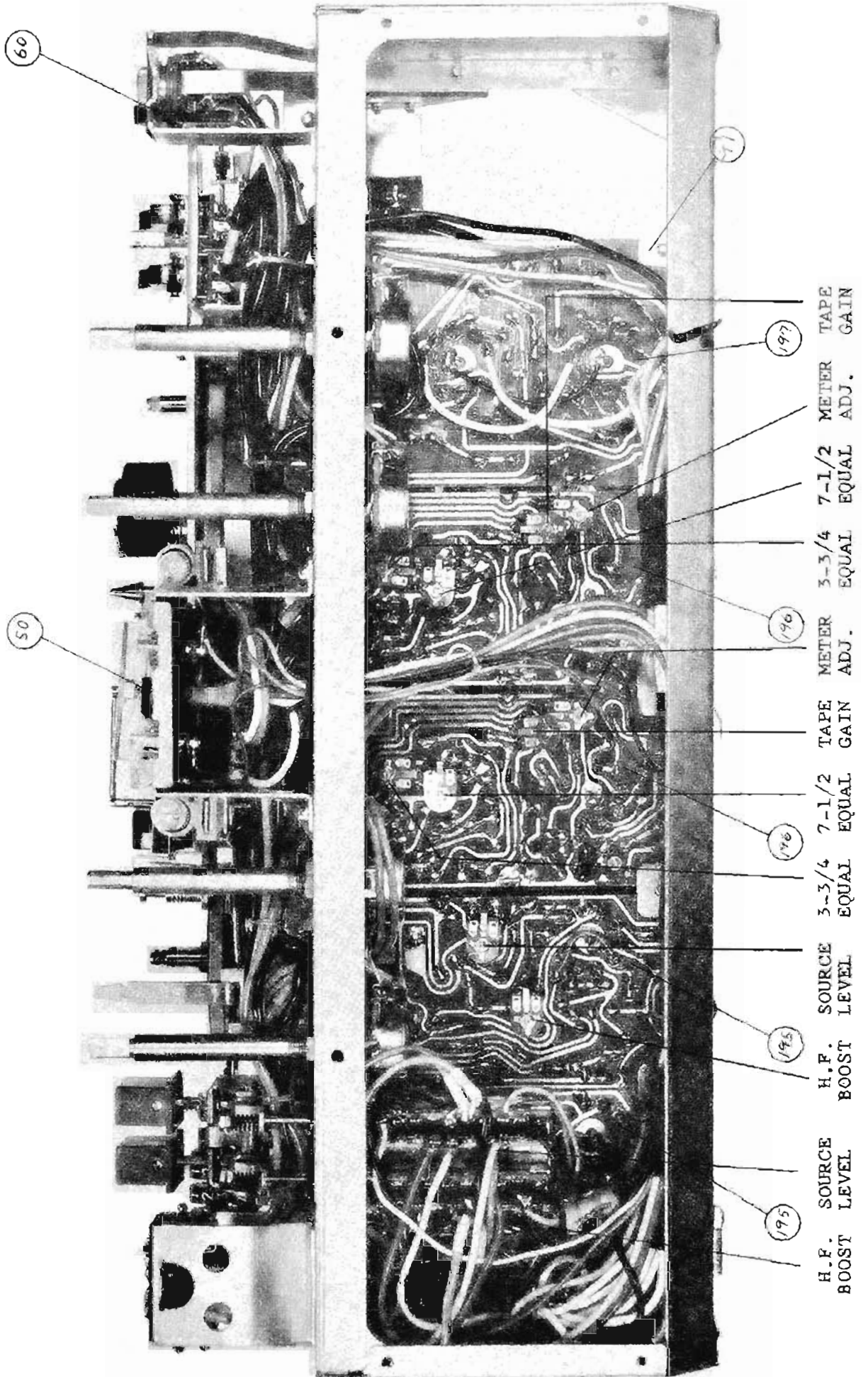

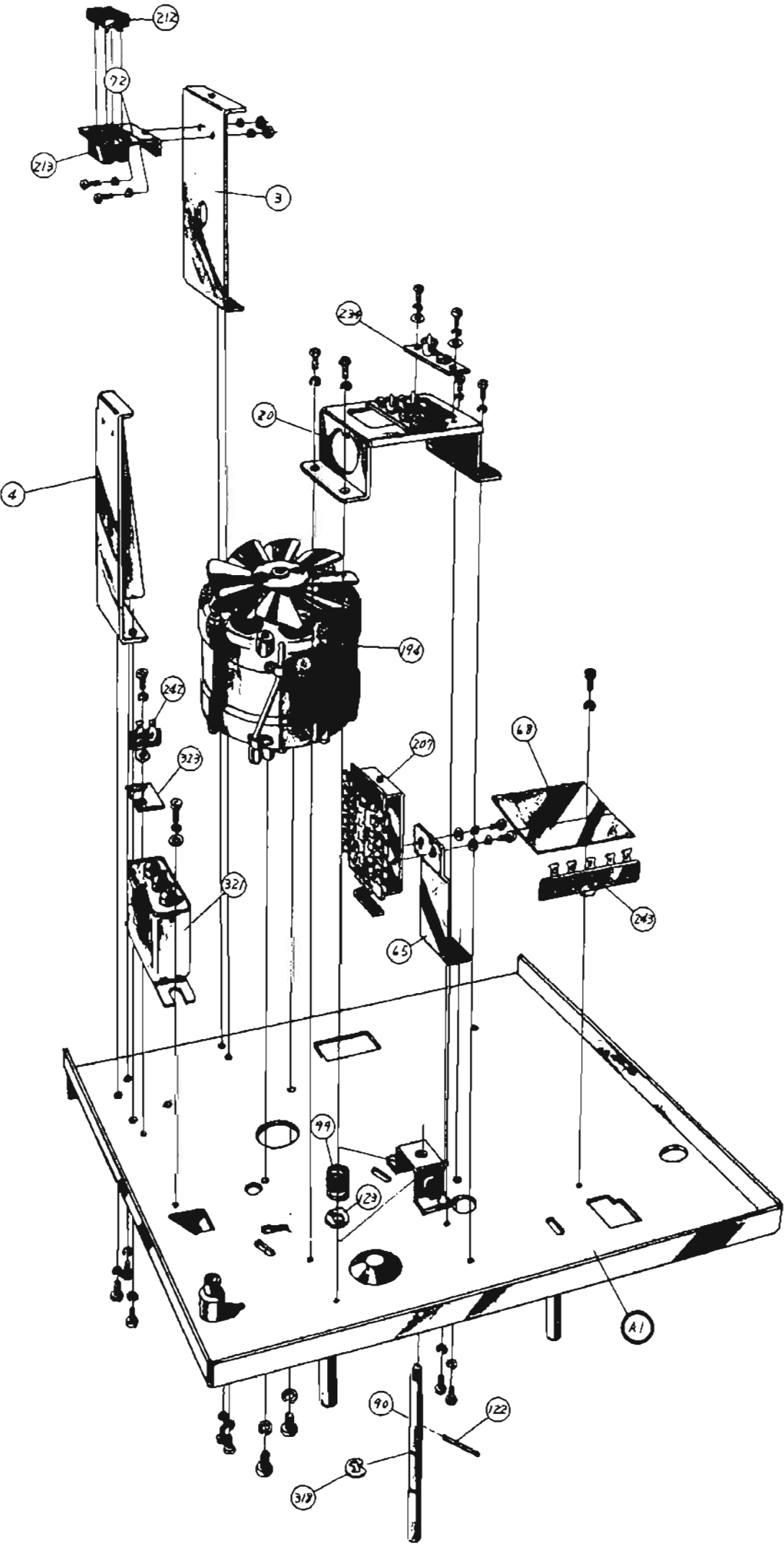

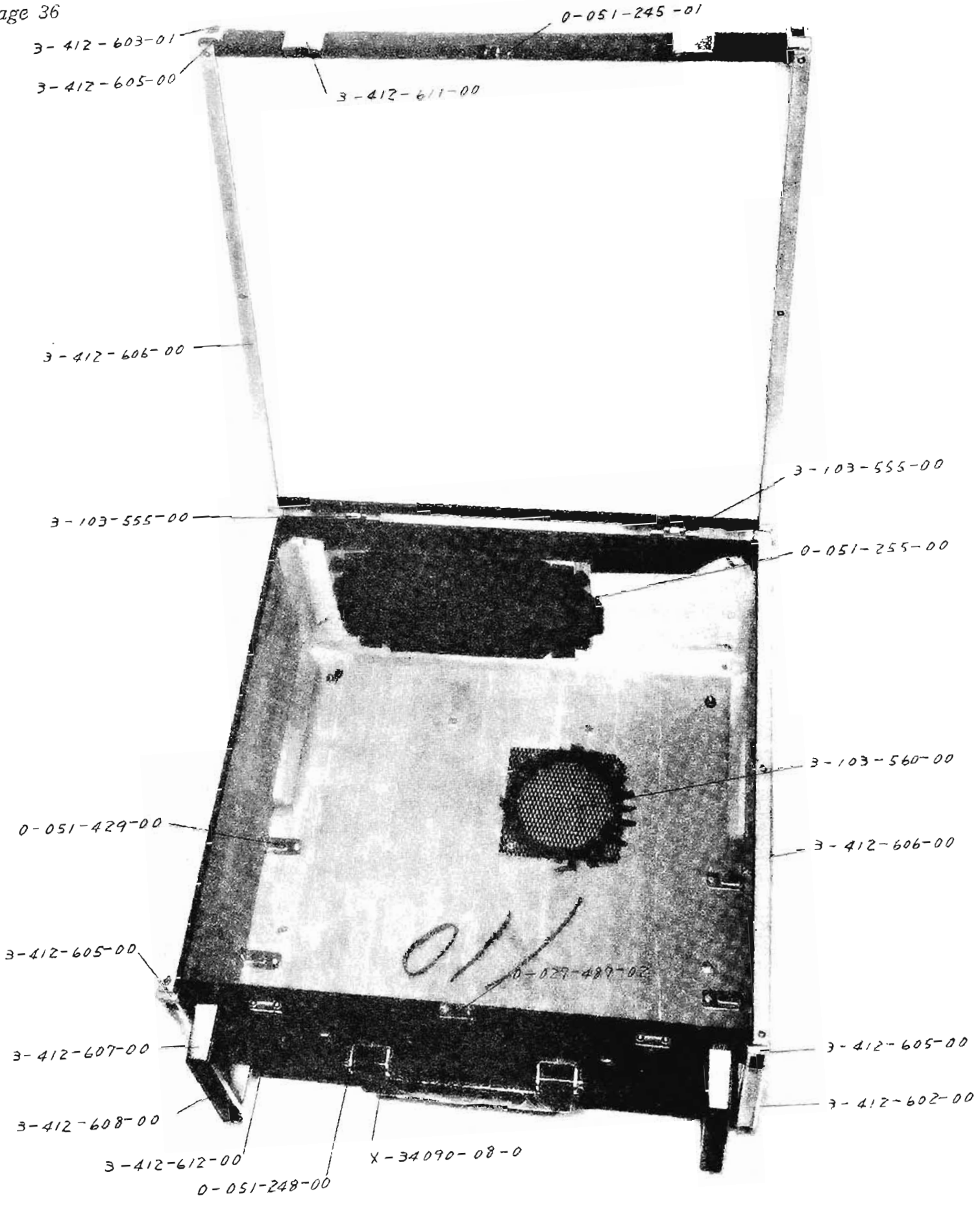

3-412-603-01

3-412-605-00

0-051-245-01

3-412-611-00

3-412-606-00

3-103-555-00

3-103-555-00

0-051-255-00

0-051-429-00

3-103-560-00

3-412-606-00

3-412-605-00

0-029-489-02

3-412-607-00

3-412-605-00

3-412-608-00

3-412-602-00

3-412-612-00

X-34090-08-0

0-051-248-00

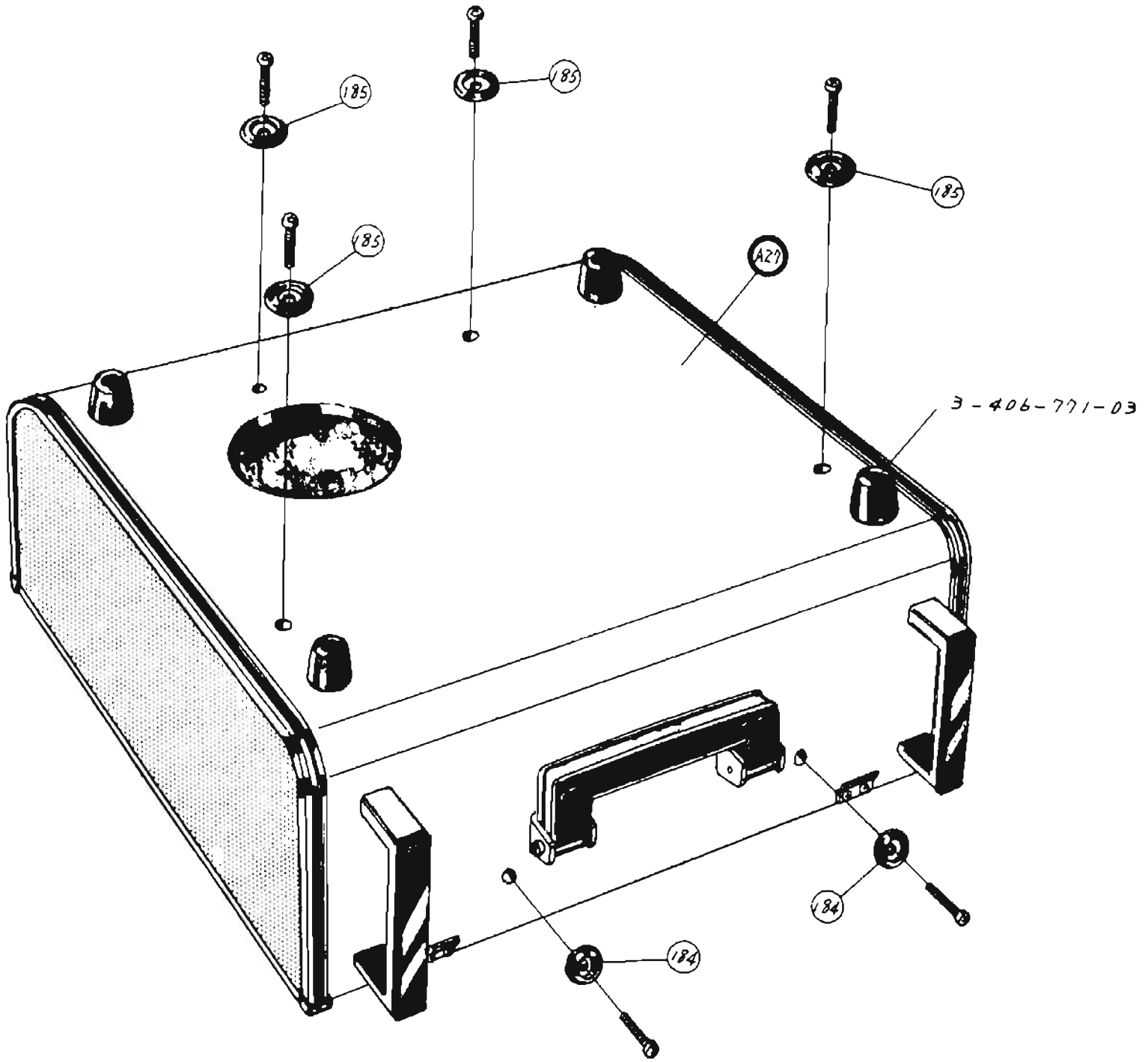

S T E R E C O R D E R600 M O D E L

<i>Ref. No.</i>	<i>Part No.</i>	<i>Description</i>	<i>Unit Price</i>
A1	X-34120-01-1	Base Plate Assembly	4.60
A2	X-34120-02-1	Amplifier Chassis Assembly	5.95
A3	X-34120-03-0	Connecting Bracket (B) Assembly	.36
A4	X-34120-05-0	Head Base Plate Assembly	1.90
A5	X-34120-06-0	Automatic Shut-Off Switch Assembly	.36
A6	X-34120-04-0	Tape Pad Hinge Assembly	.42
A7	X-00270-02-0	Pinch Lever Assembly	.65
A8	X-00270-03-0	Capstan Idler Assembly	1.25
A9	X-00270-09	Rewind Idler Arm Assembly	.42
A10	X-00270-10	Idler Shaft (C) Assembly	.30
A11	X-00270-13	Fast Forward Cam Assembly	.30
A12	X-00270-19	Take-Up Idler Assembly	1.25
A13	X-0270-25-0	Rewind Idler Assembly	.90
A14	X-00370-04-0	Stepper Arm Assembly	.30
A15	X-00370-05-0	Idler Arm Assembly	.60
A16	X-00510-65-0	Function Selector Cam Assembly	.95
A17	X-34090-20-4	Capstan Shaft Assembly	4.35
A18	X-34090-21-0	Idler Plate Assembly	.40
A19	X-34090-12-1	Speed Selector Knob Assembly	.70
A20	X-34090-16-4	Feed Reel Table Assembly	2.20
A21	X-34090-17-4	Take-Up Reel Table Assembly	2.20
A22	X-34026-44-1	Take-Up Spindle Drum Assembly	.65
A23	X-34120-11-0	Pad Shifter (C) Assembly	
A24	X-34120-08-0	Head Cover (A) Assembly	1.85
A25	X-34120-10-0	Power Push Button Assembly	.30
A26	X-34090-25	Reel Cap Assembly	.54
A27	X-34126-01-0	Cabinet Assembly	52.75
A28	X-34120-13-0	Record Button Assembly	.25
A29	X-34120-12-0	Volume Control Knob (B) Assembly	.80

Prices contained in this Parts List are subject to change without notice.

All items are available only in quantities necessary for replacement in Sony products.

Any order for unduly large quantities will not be honored.

<i>Ref. No.</i>	<i>Part No.</i>	<i>Description</i>	<i>Unit Price</i>
1	3-412-002-00	Power Supply Chassis	1.60
2	-003-00	Back Plate for Jack Location Indicating Plate	1.05
3	-004-01	Back Plate Holding Bracket	.35
4	-005-00	Panel Mounter	.30
5	-013-00	V. U. Meter Mounting Plate	.40
6	-014-00	Plate for Record/Playback Selector Shaft	.20
7	-015-00	Slide Switch Mounting Plate	.24
8	-016-00	Record Switch Selector Plate	.10
9	-017-00	Record Selector Lever	.10
10	-018-00	Record Button Plate	.10
11	-020-00	Printed Circuit Board Retainer	.05
12	-021-00	Tab for Printed Circuit Board	.05
13	-032-00	Connecting Bracket (A) for Base Plate and Amp. Chassis	.20
14	-034-00	Panel Mounting Plate (A)	.20
15	-035-00	Panel Mounting Plate (B)	.20
16	-036-00	Panel Mounting Plate (C)	.10
17	-037-00	Counter Mounting Plate	.10
18	-038-00	Record Lock Lever (A)	.15
19	-039-00	Record Lock Lever (B)	.15
20	-040-00	Socket Mounting Plate	.35
21	-041-00	Instant Stop Lever	.30
22	-042-00	Leaf Switch Mounting Plate	.12
23	-049-00	Decoration Panel	2.67
24	-050-00	Washer for Panel Decoration Ring	.05
25	-051-00	Reel Panel	4.80
26	-053-00	Head Cover Mounting Post (A)	.12
27	-054-00	Head Cover Mounting Post (B)	.10
28	-055-00	Record/Playback Selector Shaft	.10
29	-059-00	Washer for Reel Panel Fix Screw	.10
30	-060-00	Volume Control Knob Set Screw	.05
31	-061-00	Spacer for Record Selector Lever	.05
32	-063-00	Selector Lever Pull Rod (Rec./PB Selector)	.10
33	-064-00	Slide Switch Pull Rod	.10
34	-065-00	Lock Rod	.05
35	-067-00	Lock Rod Reset Spring	.05
36	-068-00	Switch Reset Spring	.05
37	-069-00	Control Panel	4.17
38	-071-00	Volume Control Knob (A) (Upper)	.25
39	-073-00	Panel Decoration Ring	.30
40	-076-00	Instant Stop Knob	.05
41	-077-00	Cover for Tape Index Counter	.10
42	-078-00	Head Terminal Plate	.10
43	-079-00	Pilot Lamp Cover	.05
44	-080-00	Erase Head Washer	.05

<i>Ref. No.</i>	<i>Part No.</i>	<i>Description</i>	<i>Unit Price</i>
45	3-412-081-00	Washer for Volume Control Knob	.05
46	-082-00	Jack Location Indicating Plate	.60
47	-083-00	Mini Jack Insulating Plate	.05
48	-084-00	Binaural Jack Insulating Plate	.05
49	-085-00	Leaf Switch Insulating Plate	.05
50	-086-00	Felt for V. U. Meter	.12
51	-088-00	Head Cover (B)	.95
52	-091-00	Connector Set Screw	.20
53	-092-00	Pull Rod	.10
54	-097-00	Location Indicating Plate	.40
55	-098-00	Printed Circuit Board Shield Case	.80
56	-103-00	Automatic Shut-Off Wire (B)	.10
57	0-051-076-00	Actuator Control Lever	.40
58	-098-02	Fast Forward Knob	.60
59	-099-00	Bracket for Muting Switch Control	.12
60	-113-00	Jack Spacer	.05
61	-206-00	Power Transformer Shielding Plate	.40
62	-210-00	Pull Rod (A) Spring	.10
63	-219-00	Muting Switch	.15
64	-220-00	Spring for Pull Rod (B)	.10
65	-237-00	Equalizer Switch Mounting Plate	.15
66	-340-00	Fast Forward Spring	.10
67	-365-00	AC Socket Cover	.10
68	-376-00	Specular Capacitor Fiber	.10
69	-380-00	Function Selector Cam Set Screw	.10
70	-426-00	Pinch Roller (B)	1.25
71	-368-00	Record Cam	.15
72	-366-00	AC Socket Mounting Plate	.20
73	-236-00	Leaf Switch Insulator	.05
74	0-027-019-00	Idler Guide Support	.12
75	-020-00	Idler Guide	.10
76	-029-00	Brake Block	.10
77	-034-00	Feed Spindle Deck	.10
78	-035-00	Thin Washer 5¢	.05
79	-036-00	Bearing Retainer	.10
80	-038-00	Bearing Cover	.10
81	-040-00	Thrust Bearer (Vulcanized Fiber)	.05
82	-061-00	Auxiliary Plate for Instant Stop Brake Arm	.10
83	-018-00	Fast Forward Cam Stopper	.10
84	-078-00	Brake Lever	.12
85	-111-00	Push Rod (A)	.12
86	-113-00	Pull Rod	.05
87	-119-00	Take-Up Spindle	.25
88	-120-00	Feed Spindle	.25

<i>Ref. No.</i>	<i>Part No.</i>	<i>Description</i>	<i>Unit Price</i>
89	0-027-121-00	Feed Spindle Spacer	.20
90	-131-00	Speed Selector Shaft	.50
91	-134-00	Stepper Shaft	.05
92	-170-00	Set Screw for Motor Pulley	.05
93	-180-00	Take-Up Spindle Spacer	.10
94	-181-00	Pinch Roller Spacer	.10
95	-191-00	Helical Spring (A)	.05
96	-193-00	Helical Spring (D)	.05
97	-194-00	Helical Spring (E)	.05
98	-197-00	Helical Spring (H)	.05
99	-198-00	Speed Selector Shaft Spring	.10
100	-200-00	Brake Block Spring	.10
101	-201-00	Fast Forward Reset Spring	.10
102	-203-00	Instant Stop Brake Arm	.15
103	-207-00	Reset Spring	.05
104	-214-00	Brake Shoe	.05
105	-216-00	Oil Absorber 5¢	.05
106	-220-00	Paper Washer 5¢	.05
107	-221-00	Paper Washer 6¢	.05
108	-230-00	Oil Retainer Cover	.05
109	-237-00	Reel Table Felt	.10
110	-246-00	Vibration Absorber	.05
111	-249-00	Brake Felt	.05
112	-250-00	Oil Retainer	.05
113	-473-00	Tape Pad (B) (Erase Head)	.05
114	-479-00	Pinch Roller Oil Absorber	.05
115	-483-00	Capstan	.45
116	0-037-018-00	Stepper Spring	.10
117	-020-00	Pinch Lever Shifter	.10
118	-028-00	Rewind Control Rod (B)	.15
119	-029-00-13	Motor Pulley	1.05
120	-040-00	Idler Spring	.10
121	-240-00	Brake Spring	.10
122	-247-00	Speed Selector Shaft Pin	.10
123	-248-00	Speed Selector Shaft Washer	.10
124	-249-00	Split Nut	.10
125	0-041-029-00	Ornamental Washer for Reel Panel	.05
126	0-056-302-00	Rec./P. B. Head Adjusting Screw	.05
127	0-045-040-00	Oscillator Transformer Mounter	.10
128	0-007-159-00	Vacuum Tube Clamp	.10
129	-238-00	Vacuum Tube Hold Spring (A)	.05
130	-239-00	Vacuum Tube Hold Spring (B)	.05
131	-121-00	Head Shield Plate	.36
132	0-041-129-00	Head Pad (PB. Head)	.05

<i>Ref. No.</i>	<i>Part No.</i>	<i>Description</i>	<i>Unit Price</i>
133	3-103-203-00	<i>Tape Guide Adjusting Spring</i>	. 05
134	-527-00	<i>Wire Retainer (Rubber)</i>	. 10
135	3-401-068-00	<i>Head Adjusting Screw</i>	. 05
136	3-403-425-01	<i>Pinch Roller Cover Plate</i>	. 05
137	3-407-040	<i>Counter Belt Pulley</i>	. 20
138	3-408-035-00	<i>Pull Rod Spring</i>	. 10
139	3-410-026-00	<i>Actuator</i>	. 10
140	-031-00	<i>Instant Stop Reset Spring</i>	. 10
141	3-413-008-01	<i>Rec./P. B. Head Adjusting Plate</i>	. 12
142	3-403-454-00	<i>Set Screw for Knob</i>	. 10
143	Y-20165-01-0	<i>Tape Index Counter VI</i>	4. 85
144	3-409-086-00	<i>Counter Pulley Shaft</i>	. 12
145	-087-00	<i>Counter Pulley Spacer</i>	. 10
146	-088-00	<i>Tape Index Counter Belt</i>	. 25
147	-097-03	<i>Idler Retainer (A)</i>	. 20
148	-101-00	<i>Nylon Washer (A)</i>	. 05
149	-102-00	<i>Nylon Washer (B)</i>	. 05
150	-103-00	<i>Function Selector Knob</i>	. 70
151	-106-00	<i>Function Selector Knob Set Screw</i>	. 10
152	-107-00	<i>Switch Cover</i>	. 10

Ref. No.	Symbol No.	Part No.	Description	Unit Price
153		3-409-108-00	Reel Panel Washer	.05
154		-109-00	Tape Guide Mounter	.20
155		-162-01	Oil Absorber for Capstan Shaft	.05
156		-163-00	Idler Thrust Washer	.05
157		-165-00	Capstan Bearing	.75
158		-201-00	Reel Cap Spacer (A) (on Reel Spindle)	.10
159		-202-00	Reel Cap Spacer (B) (on Reel Spindle)	.10
160		-188-00	Set Screw for Function Selector Cam	.12
161		0-051-081-03	Cam Shaft	.35
162		0-027-215-00	Friction Felt	.10
163		0-027-022-00	Idler Disc (B)	.10
164		3-412-047-00	Cage (C)	1.32
165		-112-00	Felt for Volume Knob	.10
166			Head Cover Escutcheon	.25
167		-044-00	Cage Reinforcing Bracket	.36
168		-128-00	Socket Mounting Bracket (B)	.20
169		-045-00	Cage (A)	1.60
170		-046-00	Cage (B)	1.25
171		-048-00	Cage (D)	2.15
172		0-037-220-00	Capstan Screw	.10
173		3-412-106-00	Tape Guide S	.10
174		3-103-201-00	Tape Guide A	.70
175		0-006-95-00	Thrust Washer	.10
176		0-027-058-00	Washer for Adjustable Screw	.10
177		3-413-114-00	Head Shield Plate	.35
178		3-412-119-00	Shield Case (A)	1.65
179		-120-00	Shield Case (B) (medium)	.25
180		-121-00	Shield Case (C) (large)	.15
181		3-409-109-00	Tape Guide	.12
182		-091-00	Push Button Washer	.05
183		-092-00	Push Button	.05
184		0-027-501-02	Special Washer	.10
185		0-051-277-00	Washer for Cabinet	.10
186	X101, 201, 102 & 202	8-720-645-00	Transistor 2SD64-5	1.10
187	V1	1-525-019-00	Vacuum Tube 6CA4	1.25
188	V2	-050-00	Vacuum Tube 12BH7-A	2.15
189	V101 & 201	-055-03	Vacuum Tube 6AN8	2.25
190	V102, 202 103 & 203	-011-03	Vacuum Tube 12AT7	2.15
191	REC. HEAD		Recording Head RP30-2902	18.80
192	P.B. HEAD		Playback Head PP30-4202L	18.80
193	ERASE HEAD		Erase Head EF18-2902	5.40
194	M	8-831-134-00	Motor HC-134	26.85
195		1-538-127-11	Printed Circuit Board (REC AMP)	.55

Ref. No.	Symbol No.	Part No.	Description	Unit Price
196		1-538-128-11	Printed Circuit Board (P/B AMP)	.55
197		-129-11	Printed Circuit Board (LINE OUT)	.80
198		1-507-080-11	Circuit Connector Jack	.40
199	T1	1-441-077-12	Power Transformer	13.30
200	T2	1-433-034-11	Oscillation Transformer	1.20
201	L101 & 201	1-409-019-12	Equalizer Coil 13mH (Variable)	.65
202	D.L.	1-431-033-11	Dummy Coil	.40
203	L102, 202, 103 & 203	1-409-103-00	Trap Coil 1mH	.50
204	S1	1-514-080-11	Push Button Switch	1.15
205	S2	-039-00	Micro Switch (AC. AUTO. Switch)	1.35
206	S101 & 201	-090-00	Slide Switch (4P-2T) (Cartridge/AUX. SW.)	.80
207	S102 & 202	1-513-081-00	Equalizer Switch (Rec./PB EQU. SW)	1.15
208	S103 & 203 104 & 204	1-514-091-01	Monitor Switch (2) Line Out ON/OFF Switch (1) (2P-2T)	.66
209	S105 & 205	1-513-179-01	Slide Switch (6P-2T) (Recording Switch)	1.05
210	M101 & 201	1-524-015-12	Level Meter (for Stereorecorder)	8.65
211	RE101 & 201	1-513-501-00	Copper-Oxide Rectifier	.75
212	CNP1 CNP2	1-506-011-01	Short-Circuiting Plug	.36
213	CN2, CN3 CNT1 & CNT2	1-509-015-01	AC Socket	.30
214	R104 & 204	1-221-122-13	Potentiometer 208K ohms (MIC Volume)	2.25
215	R105 & 205	-367-11	Potentiometer 250K ohms (LINE IN ") (A)	2.15
216	R148, 248, 149 & 249	-368-11	Potentiometer 100K ohms (LINE OUT ") (A)	2.15
217	R159 & 259	-362-11	Potentiometer 10K (B) (Bias Adj.)	1.10
218	R144 & 244	1-221-372-11	Carbon Resistor (Adjustable) 500K ohms (B)	.25
219	R4	-293-00	Carbon Resistor 10K ohms (B)	.40
220	R140 & 240	-324-01	Carbon Resistor 50K ohms (B)	.25
221	R133 & 233	-359-12	Carbon Resistor 10K ohms	.25
222	R134 & 234	-371-11	Carbon Resistor 5K ohms	.25
223	R127 & 227	-370-11	Carbon Resistor 500 ohms	.25
224	R120 & 220	-369-11	Carbon Resistor 250K ohms (A)	.25
225	J101 & 102	1-507-028-00	Miniature Jack (MIC. AUX. D Type)	.25
226	JB. M	-106-00	Miniature Jack (Binaural) (Monitor)	1.00
227	J102, 202, 103 & 203	-154-00	Miniature Pin Jack (AUX. Input) (LINE OUT)	.60
228	F	1-532-008-00	Fuse 2A SB-13220	.10
229	F	1-533-012-01	Fuse Holder	.50
230		1-509-063-11	10P Multi Connector	.65
231		1-508-012-11	14P Connector for Printed Circuit Board	1.15
232	CNJ3	1-509-060-11	11P Connector for Chassis	.55
233	CNP3	1-508-013-11	11P Plug for Amplifier	.66

<i>Ref. No.</i>	<i>Symbol No.</i>	<i>Part No.</i>	<i>Description</i>	<i>Unit Price</i>
234	CNJ101-103 CNJ201-203	1-509-034-01	2P-2P Connector (for Stereo)	.55
235	CNP101, 201, 102 & 202	-050-01	A Set of Pin Plug and Socket (Red)	.40
236	CNP103 & 203	-02	A Set of Pin Plug and Socket (Black)	.40
237	CN1	1-509-013-00	AC Socket (Special)	.55
238	PL101, 201, 102 & 202	1-518-011-00	Pilot Lamp	.10
239	PL101, 201, 102 & 202	1-517-003-00	Pilot Lamp Socket	.10
240	V1 & V2	1-526-009-00	9NP Vacuum Tube Socket	.20
241	V101, 103, 201 & 203	-044-11	9 Pin Socket (B) for Printed Circuit Board	.30
242		1-536-005-00	Terminal Strip 1-1P	.05
243		-007-00	Terminal Strip 1-4P	.10
244		-008-00	Terminal Strip 1-5P	.10
245		1-536-030-00	Terminal Strip 1-4P	.10
246		1-599-002-00	Rubber Bushing	.05
247	R1 & R2	1-207-053-11	Enameled Resistor 7P 500 ohms 10%	.70
248	R3	-050-11	Enameled Resistor 3P 1.5K ohms 10%	.45
249	R117 & 217	1-203-896-11	Carbon Resistor RD1/2L 390K ohms 5%	.10
250	R119 & 219	-803-00	Carbon Resistor RD1/2L 150K ohms 5%	.10
251	R143 & 243	-547-00	Carbon Resistor RD1/2L 50K ohms 5%	.10
252	R128, 228, 151, 251, 155, 255	-070-00	Carbon Resistor RD1/2L 10K ohms 5%	.10
253	R107 & 207	1-203-937-00	Carbon Resistors (Noiseless) RD1/4L 220K ohms 5% RD1/4L	.10
254	R110 & 210	-968-11	Carbon Resistors 39K ohms 5% RD1/4L	.10
255	R132 & 232	-954-00	Carbon Resistors 33K ohms 5% RD1/4L	.10
256	R106 & 206	-969-11	Carbon Resistors 22K ohms 5% RD1/4L	.10
257	R135 & 235	-970-11	Carbon Resistors 5.6K ohms 5% RD1/4L	.10
258	R138 & 238	-971-11	Carbon Resistors 4.7K ohms 5% RD1/4L	.10
259	R136 & 236	-972-11	Carbon Resistors 3.9K ohms 5% RD1/4L	.10
260	R137 & 237	-973-11	Carbon Resistors 3.3K ohms 5% RD1/4L	.10
261	R108 & 208	-974-11	Carbon Resistors 1.5K ohms 5% RD1/4L	.10
262	R129 & 229	-068-00	Carbon Resistors RD1/4L 8.2K ohms $\pm 5\%$.10
263	R109 & 209	-531-00	Carbon Resistors RD1/4L 5K ohms $\pm 5\%$.10
264	R7 & R8	-064-00	Carbon Resistors RD1/4L 4.7K ohms $\pm 5\%$.10
265	R147 & 247	-058-00	Carbon Resistors RD1/4L 3.3K ohms $\pm 5\%$.10
266	R158 & 258	-050-00	Carbon Resistors RD1/4L 2.7K ohms $\pm 5\%$.10
267	R116 & 216	-044-00	Carbon Resistors RD1/4L 2K ohms $\pm 5\%$.10
268	R102, 202, 103 & 203	-039-00	Carbon Resistors RD1/4L 1.5K ohms $\pm 5\%$.10
269	R125 & 225	-528-00	Carbon Resistors RD1/4L 3.7K ohms $\pm 5\%$.10

<i>Ref. No.</i>	<i>Symbol No.</i>	<i>Part No.</i>	<i>Description</i>	<i>Unit Price</i>
270	R24, 224, 152, 156, 256	1-203-852-11	Carbon Resistor RD1/4L 820 ohms $\pm 5\%$.10
271	R126, 226	-143-00	Carbon Resistor RD1/4L 390 ohms $\pm 5\%$.10
272	R142, 242, R9	-898-11	Carbon Resistor RD1/4L 250 ohms $\pm 5\%$.10
273	R130, 230	-127-00	Carbon Resistor RD1/4L 68 ohms $\pm 5\%$.10
274	R122, 222	-116-00	Carbon Resistor RD1/4L 750K ohms $\pm 5\%$.10
275	R112, 212, 113, 213, 114, 214, 141, 241, 160, 260	-100-00	Carbon Resistor RD1/4L 100K ohms $\pm 5\%$.10
276	R115, 215	1-203-123-00	Carbon Resistor RD1/4L 120K ohms $\pm 5\%$.10
277	R5, R6	1-203-095-00	Carbon Resistor RD1/4L 47K ohms $\pm 5\%$.10
278	R118, 218	-089-00	Carbon Resistor RD1/4L 33K ohms $\pm 5\%$.10
279	R101, 201, 111, 211	-083-00	Carbon Resistor RD1/4L 22K ohms $\pm 5\%$.10
280	R146, 246	-130-00	Carbon Resistor RD1/4L 18K ohms $\pm 5\%$.10
281	R131, 231	-128-00	Carbon Resistor RD1/4L 12K ohms $\pm 5\%$.10
282	R153, 253, 157, 257	-069-00	Carbon Resistor RD1/4L 10K ohms $\pm 5\%$.10
283	C3, C4	1-125-004-00	Electrolytic Capacitor 40uF x 2 350WV	1.45
284	C5	1-119-033-00	Electrolytic Capacitor 40uF 350WV	1.00
285	C7	1-119-024-00	Electrolytic Capacitor 10uF 350WV	.35
286	C132, 232, 134, 234	-103-11	Electrolytic Capacitor 5uF 150WV	.25
287	C110, 210	1-121-180-00	Electrolytic Capacitor 10uF 350WV	.65
288	C109, 209	-168-00	Electrolytic Capacitor 1uF 350WV	.10
289	C137, 237	-189-11	Electrolytic Capacitor 1uF 150WV	.35
290	C121, 221	-190-11	Electrolytic Capacitor 200uF 25WV	.50
291	C106, 206	-151-00	Electrolytic Capacitor 100uF 25WV	.45
292	C103, 203, 120, 220	-138-00	Electrolytic Capacitor 30uF 15WV	.20
293	C125, 225	-191-11	Electrolytic Capacitor 350uF 12WV	.25
294	C105, 205	-122-00	Electrolytic Capacitor 50uF 12WV	.20
295	C122, 222	-187-11	Electrolytic Capacitor 100uF 10WV	.30
296	C104, 204, 108, 208, 127, 227	-115-00	Electrolytic Capacitor 100uF 6WV	.20
297	C111, 211, 128, 228	1-105-229-13	Mylar Capacitor 0.2uF 250WV	.75
298	C6	1-115-012-11	Oil Tubular 0.1uF 400WV	.15
299	C112, 212, 129, 229	1-105-035-12	Mylar Capacitor 100WV MX 0.05uF	.15
300	C117, 217	-017-11	Mylar Capacitor 100WV MFL 0.01uF	.10
301	C115, 215	-016-12	Mylar Capacitor 100WV MX 0.001uF	.10
302	C126, 226	-037-11	Mylar Capacitor 50WV MFL 0.02uF	.35
303	C107, 207, 101, 201	-049-11	Mylar Capacitor 50WV MFL 0.01uF	.25

Ref. No.	Symbol No.	Part No.	Description	Unit Price
304	C102, 202, 124, 224, 131, 231, 133, 233	1-105-034-11	Mylar Capacitor 100WV MFL 0.02uF	.10
305	C123, 223	-067-11	Mylar Capacitor 50WV MFL 0.01uF	.10
306	C119, 219, 130, 230	-104-11	Mylar Capacitor 50WV MFL 0.002uF	.10
307	C135, 235, 136, 236	-141-11	Mylar Capacitor 100WV MFL 0.003uF	.10
308	C116, 216	-268-11	Mylar Capacitor 100WV MFL 0.009uF	.10
309	C8, C9, C1	1-109-062-11	Mica Capacitor 100WV 0.003uF	.10
310	C114, 214	-004-00	Mica Capacitor 500WV 200PF	.10
311	C113, 213	-063-11	Mica Capacitor 500WV 30PF	.10
312	C118, 218	1-115-062-00	Oil Tubular Paper Capacitor 0.8uF	.85
313	C11	1-117-008	MP Capacitor 250WV 0.5uF	.35
314	C2	-017-11	MP Capacitor 600WV 0.3uF	.20
315	C1	1-113-017-00	MP Capacitor (Metal Cased) 250WV 1.5 + 0.5uF	1.45
316		7-624-107-01	Retaining Ring E-3.2	
317		-108-01	Retaining Ring E-4	
318		-109-01	Retaining Ring E-5	
319		1-507-154-00	Pin Jack 2P	.60
320		1-514-090-11	Slide Switch 4P-2T	.80
321		1-113-010-00	MP Capacitor 1.5 + 0.5uF	1.50
322		7-626-203-41	Split Nut 1.20 x 15	
323		0-051-428-00	Lug Terminal Insulator	.05
324	R120, 220, 123, 223, 145, 245, 150, 250, 154, 254	1-203-149-00	Carbon Resistor RD1/4L 100 ohms 5%	.10
325	X103, 203	8-720-644-00	Transistor 2SD64-4	1.10

SONY CORP.

Symbol for screw consists of one alphabetical character followed by two arabic numerals. The alphabetical character denotes type of head; first numeral is the diameter of screw in millimeters, and the second numeral denotes length of threaded portion in millimeters.

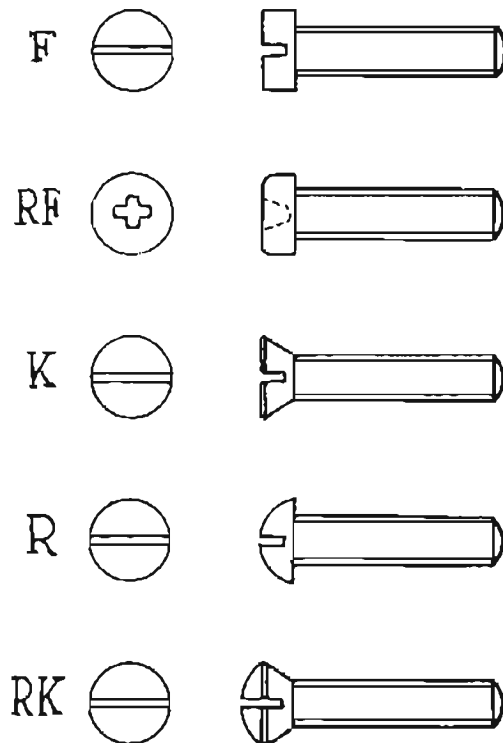

<u>DESCRIPTION</u>	<u>PRICE PER 100 PCS.</u>
Iron Screw F	
F 2 x 26	\$5.00
F 3 x 4	.50
F 3 x 6	.50
F 3 x 8	.50
F 3 x 12	.50
F 4 x 6	1.00
F 4 x 8	1.00
F 4 x 12	1.00
Brass Screw F	
F 1.4 x 3	1.00

<u>DESCRIPTION</u>		<u>PRICE PER 100 PCS.</u>
Brass Screw K		
K 2 x 3	-	\$ 1.00
K 2 x 4	-	.50
K 2 x 14	-	.50
K 2 x 24	-	4.00
K 2.6 x 6	-	.50
K 4 x 8	-	1.00
Brass Screw R		
R 2 x 2	-	1.00
R 2 x 3	-	.50
R 2 x 4	-	.50
R 3 x 4	-	.50
Brass Screw RF (+ top)		
2.6 x 6	-	2.00
3 x 4	-	2.00
3 x 6	-	2.00
3 x 8	-	2.00
3 x 12	-	2.00
3 x 25	-	3.00
Rivet		
K 2.6 x 4	-	.50
Pointed top set screw		
4 x 5	-	1.00
Cotter pin		
2 ϕ x 16	-	.50
Taper pin		
2 ϕ x 20	-	5.00
Pin		
#00 x 1/8	-	.50
Brass nut		
2 ϕ , 2.6 ϕ , 3 ϕ , 4 ϕ	-	1.00
Brass lock nut		
3 ϕ	-	.50
4 ϕ	-	.50
Brass washer		
2 ϕ	-	.50
3 ϕ	-	.50
6 ϕ	-	1.00
Spring washer		
2 ϕ	-	.50
2.6 ϕ	-	.50
3 ϕ	-	.50
4 ϕ	-	.50