

AVD-LS10

SERVICE MANUAL

Ver 1.1 2004.05

AEP Model
UK Model



| | |
|------------------------------------|--------|
| Model Name Using Similar Mechanism | NEW |
| Mechanism Type | DP-5RM |
| Base Unit Name | NEW |
| Optical Pick-up Name | NEW |

SPECIFICATIONS

Amplifier section

Stereo mode 40 W + 40 W (8 ohms at 1 kHz, THD 0.7 %)
Surround mode Front: 40 W + 40 W (THD 0.7 %)
Center*: 40 W
Rear*: 40 W + 40 W (8 ohms at 1 kHz, THD 0.7 %)

* Depending on the source, there may be no sound output.

Inputs (Analog) VIDEO 1, VIDEO 2, TV-AUDIO:
Sensitivity: 150 mV
Impedance: 50 kilohms

Inputs (Digital) VIDEO 2 (Optical):
Sensitivity: –

Outputs (Analog) VIDEO 1 (AUDIO OUT):
Voltage: 2 V
Impedance: 1 kilohms
SUBWOOFER AUDIO OUT:
Voltage: 3 V
Impedance: 1 kilohms

PHONES:
Accepts low- and high-impedance headphones

Outputs (Digital) DIGITAL OUT OPTICAL (CD/DVD)
Sensitivity: –

CD/DVD system

Laser Semiconductor laser
(CD: $\lambda = 780$ nm, DVD: $\lambda = 650$ nm)
Emission duration: continuous

Signal format system NTSC/PAL

Frequency response (at 2 CH STEREO mode)
DVD (PCM): 20 Hz to 20 kHz (+0.5 dB, -3.0 dB)
CD: 20 Hz to 20 kHz (+0.5 dB, -3.0 dB)

Signal-to-noise ratio More than 75 dB (VIDEO 1 (AUDIO) connectors only)

Harmonic distortion Less than 0.5 %

FM tuner section

System PLL quartz-locked digital synthesizer system
Tuning range: 87.5 – 108.0 MHz (50 kHz step)
Antenna FM wire antenna
Antenna terminals 75 ohms, unbalanced
Intermediate frequency 10.7 MHz

AM tuner section

System Tuner section:
PLL quartz-locked digital synthesizer system
Tuning range
North American model: 531 – 1,602 kHz (with the interval set at 9 kHz)
Antenna Loop antenna
Intermediate frequency 450 kHz

Video section (EURO AV)

Outputs Video: 1 V_{p-p} 75 ohms

General

Power requirements 230 V AC, 50/60 Hz
Power consumption 70 W
1.3 W (in the standby mode)
Dimensions (approx.) 430 x 83 x 355 mm (17 x 3 x 14 inches) (w/h/d) incl. projecting parts
Mass (approx.) 5.0 kg (11 lb 7 oz)
Operating temperature 5°C to 35°C (41°F to 95°F)
Operating humidity 5 % to 90 %
Supplied accessories See page 14.

— Continued on next page —

AUDIO CD/DVD RECEIVER

9-877-629-02

2004E02-1

© 2004.05

Sony Corporation

Home Audio Company

Published by Sony Engineering Corporation

SONY®

Supplied accessories

- AM loop antenna (1)
- FM wire antenna (1)
- Remote Commander (remote) RM-LS10 (1)
- R6 (size AA) batteries (2)
- Video cord (PINPLUG X 1 ↔ PINPLUG X 1) (1)

Design and specifications are subject to change without notice.

Laser component in this product is capable of emitting radiation exceeding the limit for Class 1.



This appliance is classified as a CLASS 1 LASER product. The CLASS 1 LASER PRODUCT MARKING is located on the rear exterior.



This caution label is located inside the unit.

CAUTION

Use of controls or adjustments or performance of procedures other than those specified herein may result in hazardous radiation exposure.

Notes on chip component replacement

- Never reuse a disconnected chip component.
- Notice that the minus side of a tantalum capacitor may be damaged by heat.

Flexible Circuit Board Repairing

- Keep the temperature of soldering iron around 270°C during repairing.
- Do not touch the soldering iron on the same conductor of the circuit board (within 3 times).
- Be careful not to apply force on the conductor when soldering or unsoldering.

NOTES ON HANDLING THE OPTICAL PICK-UP BLOCK OR BASE UNIT

The laser diode in the optical pick-up block may suffer electrostatic break-down because of the potential difference generated by the charged electrostatic load, etc. on clothing and the human body. During repair, pay attention to electrostatic break-down and also use the procedure in the printed matter which is included in the repair parts. The flexible board is easily damaged and should be handled with care.

NOTES ON LASER DIODE EMISSION CHECK

The laser beam on this model is concentrated so as to be focused on the disc reflective surface by the objective lens in the optical pick-up block. Therefore, when checking the laser diode emission, observe from more than 30 cm away from the objective lens.

LASER DIODE AND FOCUS SEARCH OPERATION CHECK

Carry out the “S curve check” in “CD section adjustment” and check that the S curve waveform is output several times.

SAFETY-RELATED COMPONENT WARNING!!

COMPONENTS IDENTIFIED BY MARK \triangle OR DOTTED LINE WITH MARK \triangle ON THE SCHEMATIC DIAGRAMS AND IN THE PARTS LIST ARE CRITICAL TO SAFE OPERATION. REPLACE THESE COMPONENTS WITH SONY PARTS WHOSE PART NUMBERS APPEAR AS SHOWN IN THIS MANUAL OR IN SUPPLEMENTS PUBLISHED BY SONY.

TABLE OF CONTENTS

| | |
|--|----|
| 1. SERVICING NOTE | 4 |
| 2. GENERAL | 6 |
| 3. DIAGRAMS | |
| 3-1. Block Diagrams – DVD Section (1/2) – | 9 |
| 3-2. Block Diagrams – DVD Section (2/2) – | 10 |
| 3-3. Block Diagrams – IN/OUT Section – | 11 |
| 3-4. Block Diagrams – POWER AMP Section – | 12 |
| 3-5. Block Diagrams – DISPLAY/POWER Section – | 13 |
| 3-6. Printed Wiring Board – DVD Section (Side A)– | 14 |
| 3-7. Printed Wiring Board – DVD Section (Side B)– | 15 |
| 3-8. Schematic Diagram – DVD Section (1/4) – | 16 |
| 3-9. Schematic Diagram – DVD Section (2/4) | 17 |
| 3-10. Schematic Diagram – DVD Section (3/4) | 18 |
| 3-11. Schematic Diagram – DVD Section (4/4) | 19 |
| 3-12. Printed Wiring Board – Main Section (Side A) – | 20 |
| 3-13. Printed Wiring Board – Main Section (Side B) – | 21 |
| 3-14. Schematic Diagram – Main Section (1/5) – | 22 |
| 3-15. Schematic Diagram – Main Section (2/5) – | 23 |
| 3-16. Schematic Diagram – Main Section (3/5) – | 24 |
| 3-17. Schematic Diagram – Main Section (4/5) – | 25 |
| 3-18. Schematic Diagram – Main Section (5/5) – | 26 |
| 3-19. Schematic Diagram – Panel Section – | 26 |
| 3-20. Printed Wiring Board – Panel Section – | 27 |
| 3-21. Printed Wiring Board – Power Section – | 28 |
| 3-22. Schematic Diagram – Power Section – | 29 |
| 4. EXPLODED VIEWS | |
| 4-1. Chassis Section | 31 |
| 4-2. Deck Section | 32 |
| 5. ELECTRICAL PARTS LIST | 33 |

SECTION 1 SERVICING NOTE

SERVICE POSITION

• **DVD MECHANISM**

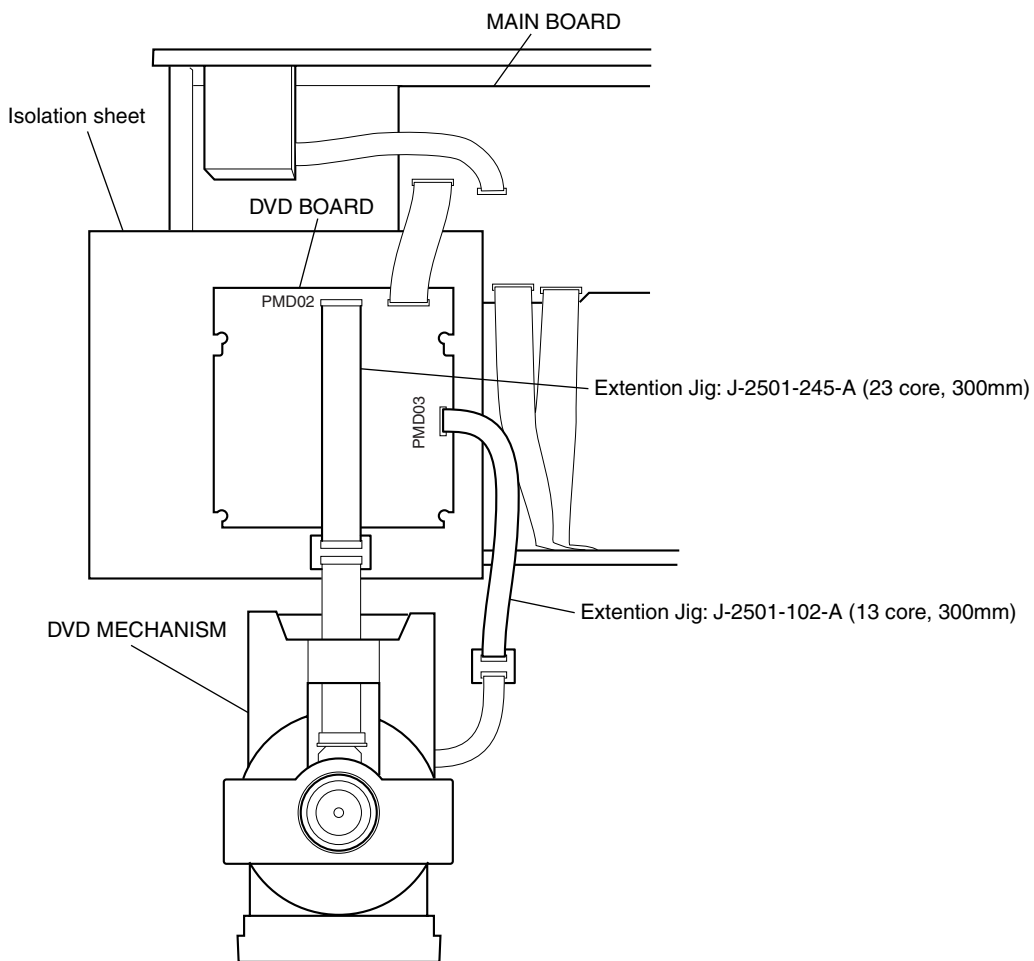

• **NOTE FOR FLAT CABLE CONNECTION**

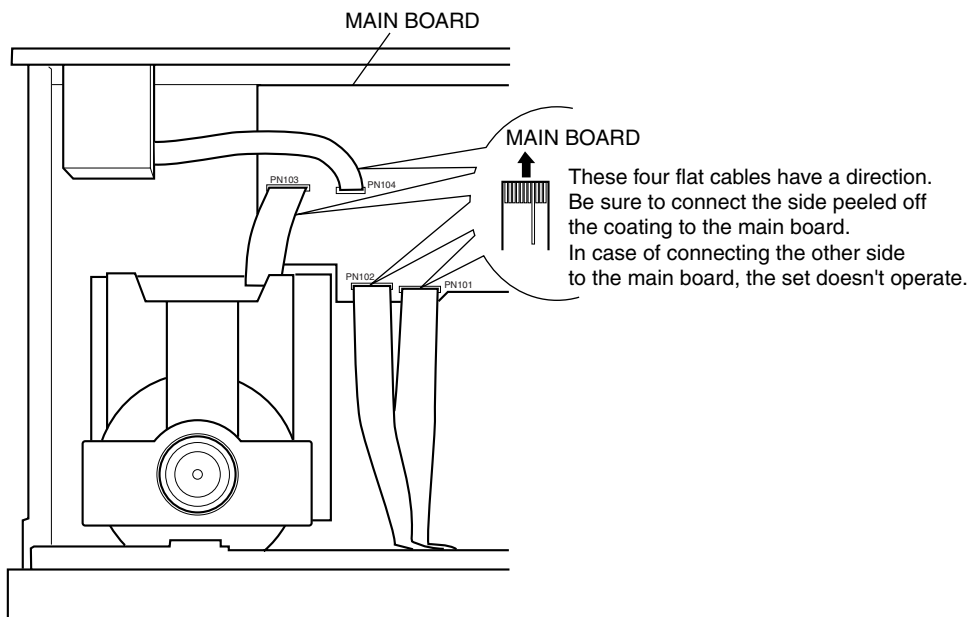

• CLEANING THE OPTICAL PICK-UP

Note 1: In cleaning the lens, do not apply an excessive force
As the optical pick-up is vulnerable, application of excessive force could damage the lens holder.

Note 2: In cleaning, do not use a cleaner other than exclusive cleaning liquid. (KK-91 or isopropyl alcohol)

Note 3: Wipe the objective lens spirally from center toward outside. (See Figure A)

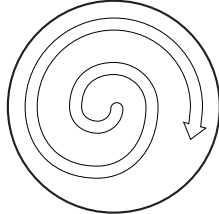



(Figure A)



• DISC TRAY LOCK

The disc tray lock function for the antitheft of an demonstration disc in the store is equipped.

Setting Procedure :

1. Press the  button of the main unit.
2. Put the disc into the tray.
3. Press two buttons of  and  simultaneously for five seconds.
4. The message “LOCKED” is displayed and the tray is locked.

Releasing Procedure :

1. Press two buttons of  and  simultaneously for five seconds again.
2. The message “UNLOCKED” is displayed and the tray is unlocked.

Note : When “LOCKED” is displayed, the tray lock is not released by turning power on/off with the  button.

Index to Parts and Controls

For more information, refer to the pages indicated in parentheses.

Front Panel

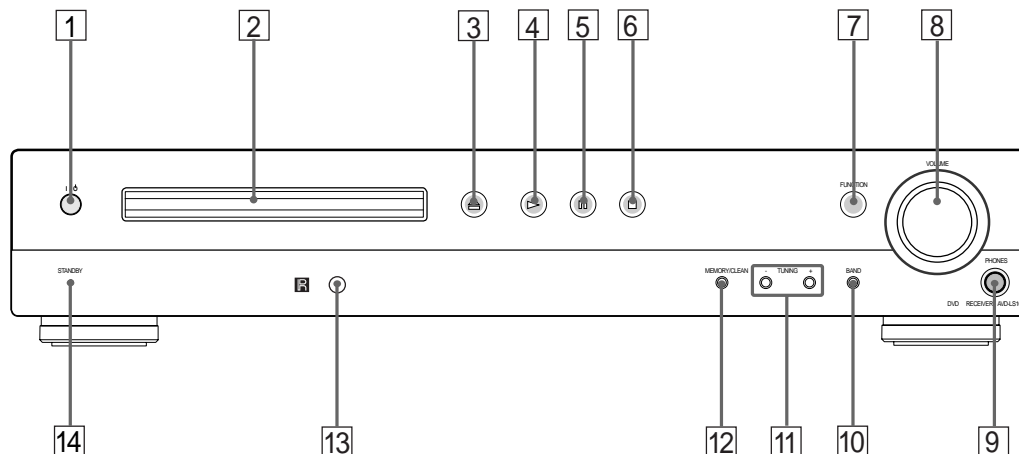

- 1 POWER switch
- 2 Disc tray
- 3 ≡ (open/close)
- 4 ▷ (play)
- 5 || (pause)
- 6 ■ (stop)
- 7 FUNCTION

- 8 VOLUME control
- 9 PHONES jack
- 10 BAND
- 11 TUNING +/-
- 12 MEMORY/CLEAR
- 13 (remote sensor)
- 14 STANDBY indicator

Rear Panel

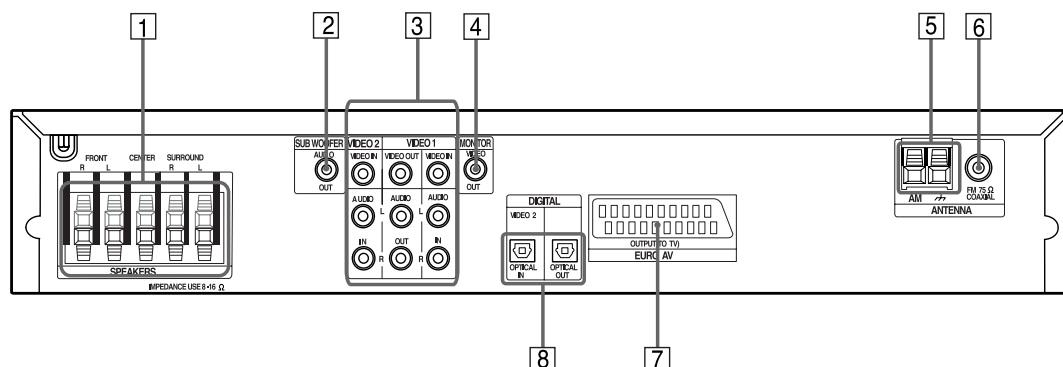

- 1 SPEAKERS jacks
- 2 SUBWOOFER AUDIO OUT jack
- 3 VIDEO 1/2 jacks
- 4 MONITOR OUT jack

- 5 AM antenna
- 6 FM 75Ω COAXIAL antenna
- 7 EURO AV OUTPUT (TO TV) jack
- 8 DIGITAL IN/OUT OPTICAL jacks

This section is extracted from instruction manual.

Remote

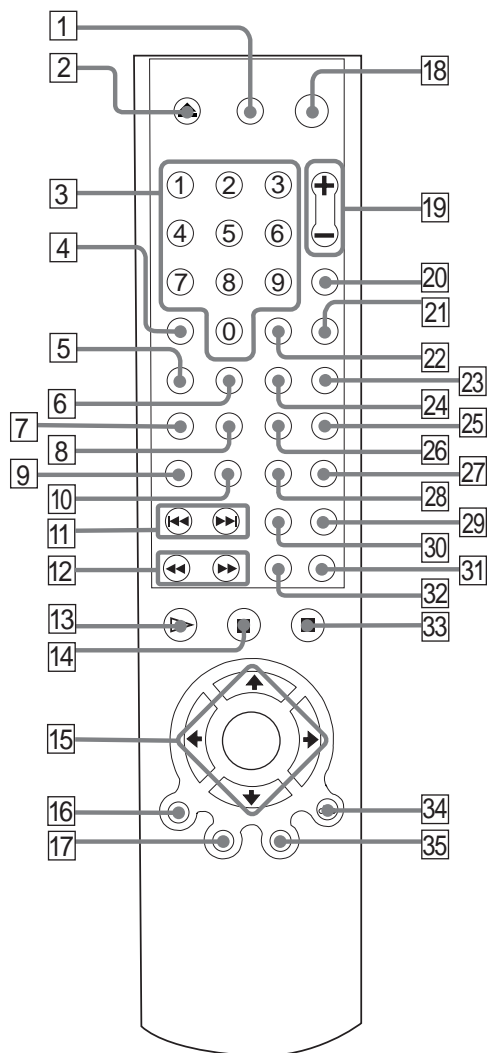

- 1 TV I/⏻ (on/standby)
- 2 OPEN/CLOSE
- 3 Number buttons
- 4 CLEAR
- 5 FUNCTION
- 6 BAND
- 7 PLAY MODE
- 8 REPEAT
- 9 DIMMER
- 10 TEST TONE
- 11 ⏮/⏭, PRESET +/-
- 12 ⏪/⏩ SLOW SCAN +/-
- 13 ▷ (play)
- 14 ⏸ (pause)
- 15 ⏪/⏩/⏮/⏭/ENTER
- 16 DVD DISPLAY
- 17 DVD TOP MENU
- 18 I/⏻ (on/standby)
- 19 VOLUME +/-
- 20 MUTING
- 21 TV/VIDEO
- 22 RDS
- 23 DOLBY PL/PLII
- 24 STEREO/MONO
- 25 2CHANNEL
- 26 REPEAT A-B
- 27 LEVEL
- 28 DELAY
- 29 ANGLE
- 30 SUBTITLE
- 31 AUDIO
- 32 DVD SETUP
- 33 ■ (stop)
- 34 ↶ RETURN
- 35 DVD MENU

Note

This remote control glows in the dark. However, before glowing, the remote must be exposed to light for awhile.

SECTION 3 DIAGRAMS

THIS NOTE IS COMMON FOR PRINTED WIRING BOARDS AND SCHEMATIC DIAGRAMS.
(In addition to this, the necessary note is printed in each block.)

For schematic diagrams.

Note:

- All capacitors are in μF unless otherwise noted. pF: $\mu\mu\text{F}$ 50 WV or less are not indicated except for electrolytics and tantalums.
- All resistors are in Ω and $1/4\text{W}$ or less unless otherwise specified.
- Δ : internal component.
- : panel designation.

Note:

The components identified by mark Δ or dotted line with mark Δ are critical for safety. Replace only with part number specified.

- : B+ Line.
- : B- Line.
- : adjustment for repair.
- Voltages and waveforms are dc with respect to ground under no-signal (detuned) conditions.
- DVD board section
 - no mark: DVD STOP
 - () : DVD PLAY
 - * : Impossible to measure
- Other board section
 - no mark: FM
 - () : DVD PLAY
 - * : Impossible to measure
- Voltages are taken with a VOM (Input impedance 10 M Ω). Voltage variations may be noted due to normal production tolerances.

- Waveforms are taken with a oscilloscope. Voltage variations may be noted due to normal production tolerances. no mark : STOP
- Circled numbers refer to waveforms.
- Signal path.
 - : FM
 - ⇌ : CD
 - ⇌⇌ : DVD
 - ⇌⇌⇌ : VIDEO

For printed wiring boards.

Note:

- : parts extracted from the component side.
- \circ : Through hole.
- : Pattern from the side which enables seeing. (The other layers' patterns are not indicated.)

Caution:

| | |
|--------------------|--|
| Pattern face side: | Parts on the pattern face side seen from the pattern face are indicated. |
| Parts face side: | Parts on the parts face side seen from the parts face are indicated. |

• Indication of transistor

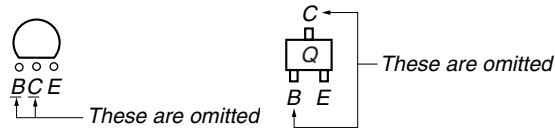

3-1. BLOCK DIAGRAM - DVD SECTION (1/2) -

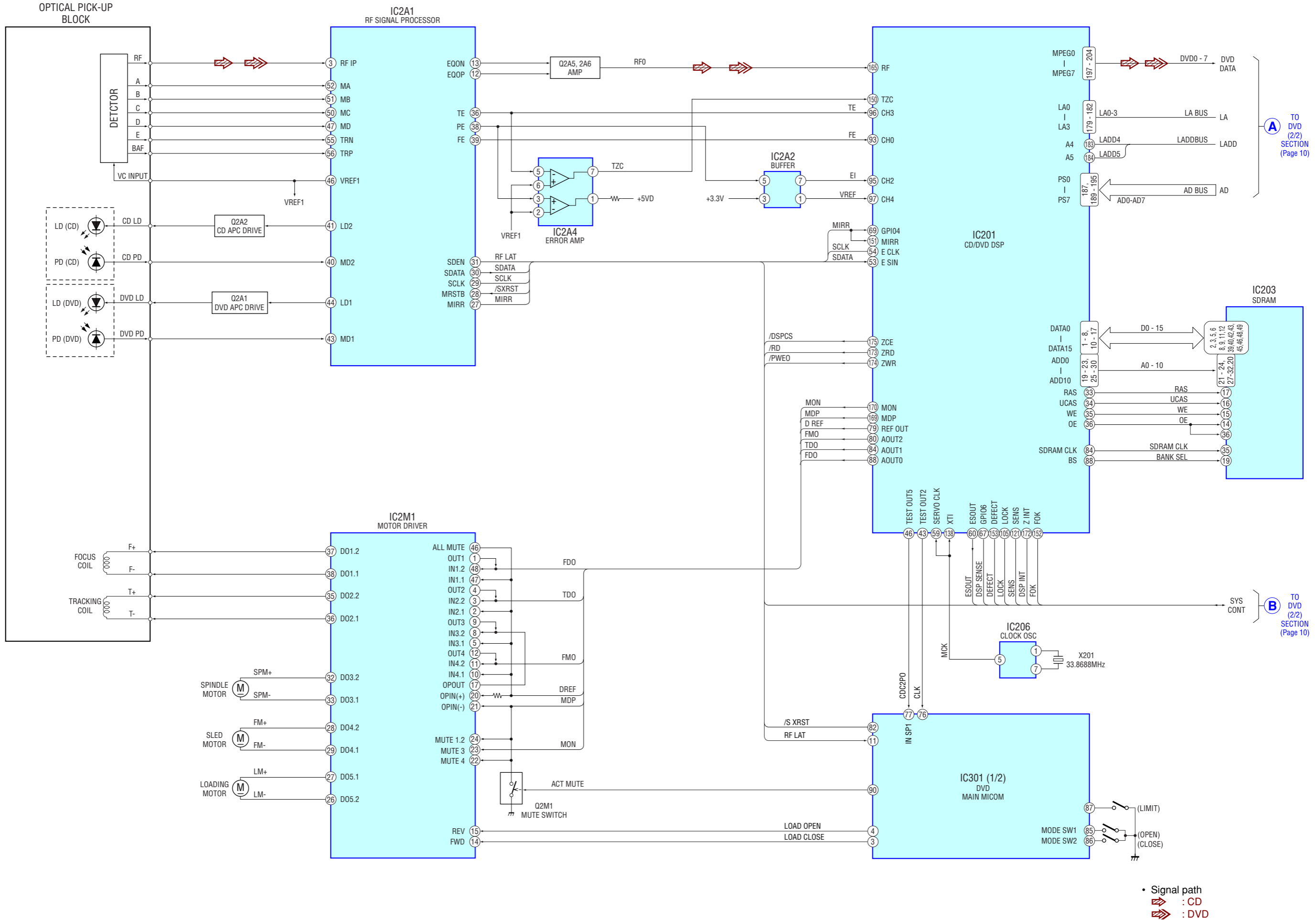

(A) TO DVD (2/2) SECTION (Page 10)

(B) TO DVD (2/2) SECTION (Page 10)

• Signal path
 : CD
 : DVD

3-2. BLOCK DIAGRAM - DVD SECTION (2/2) -

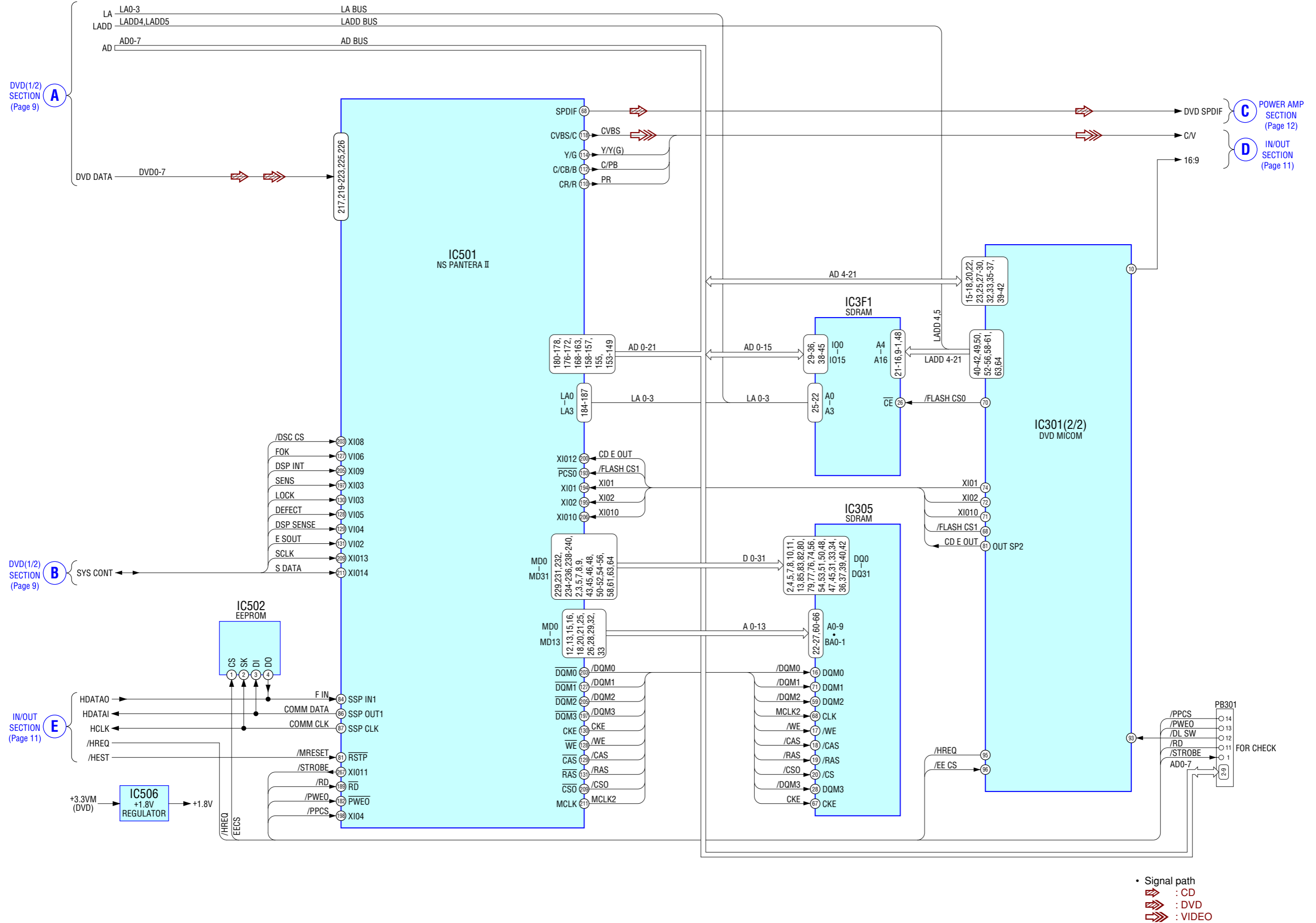

3-3. BLOCK DIAGRAM - IN/OUT SECTION -

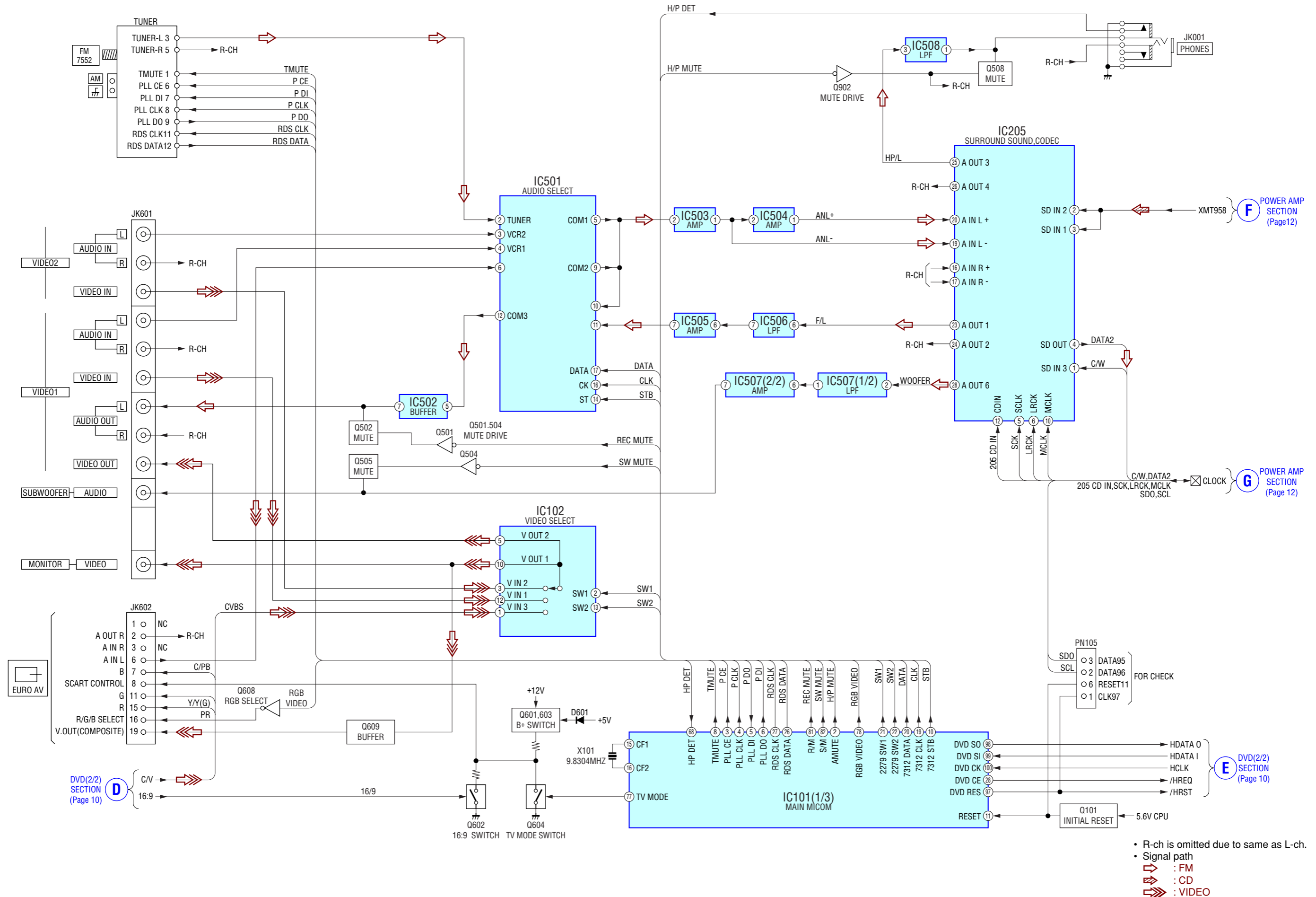

3-4. BLOCK DIAGRAM – POWER AMP SECTION –

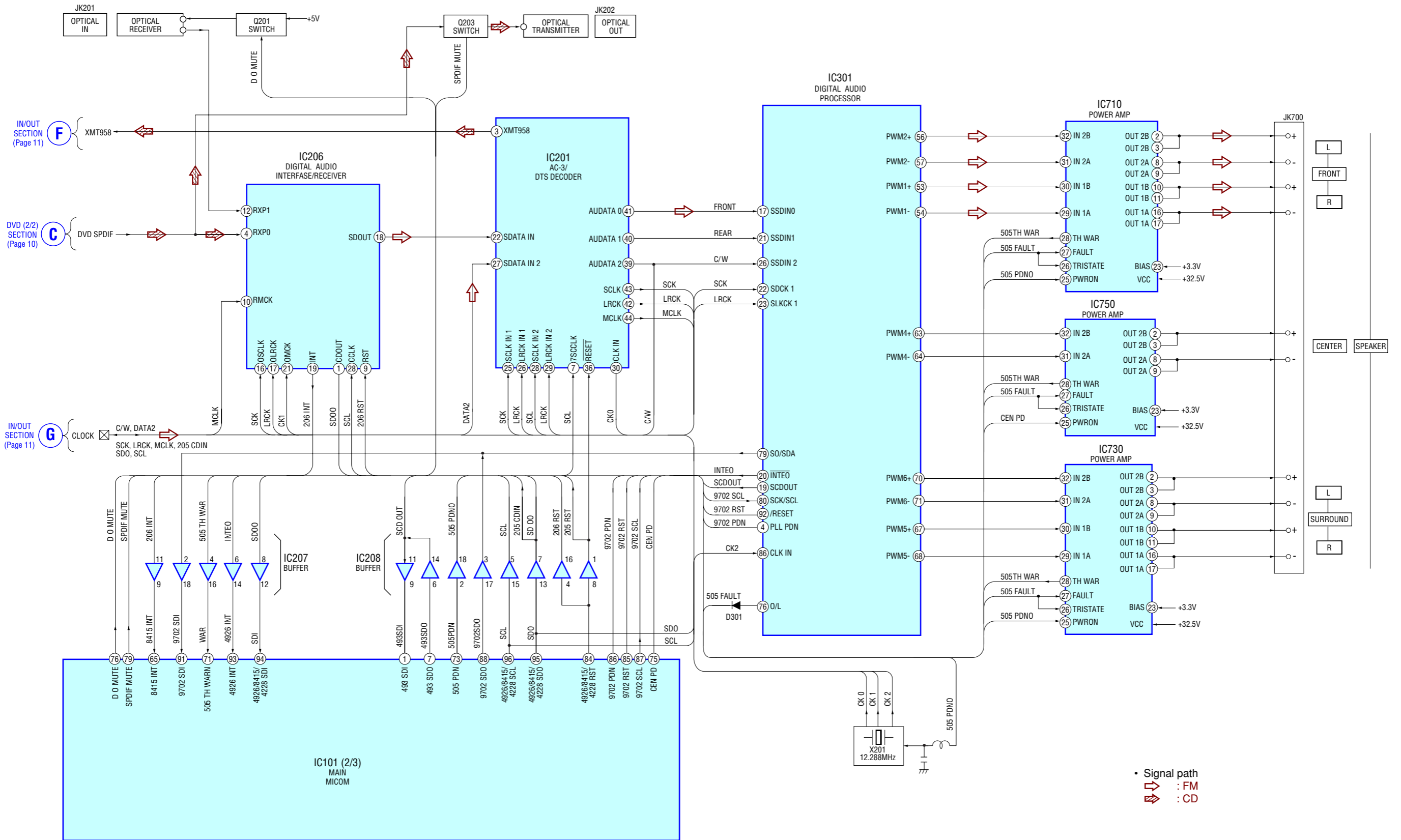

3-5. BLOCK DIAGRAM – DISPLAY/POWER SECTION –

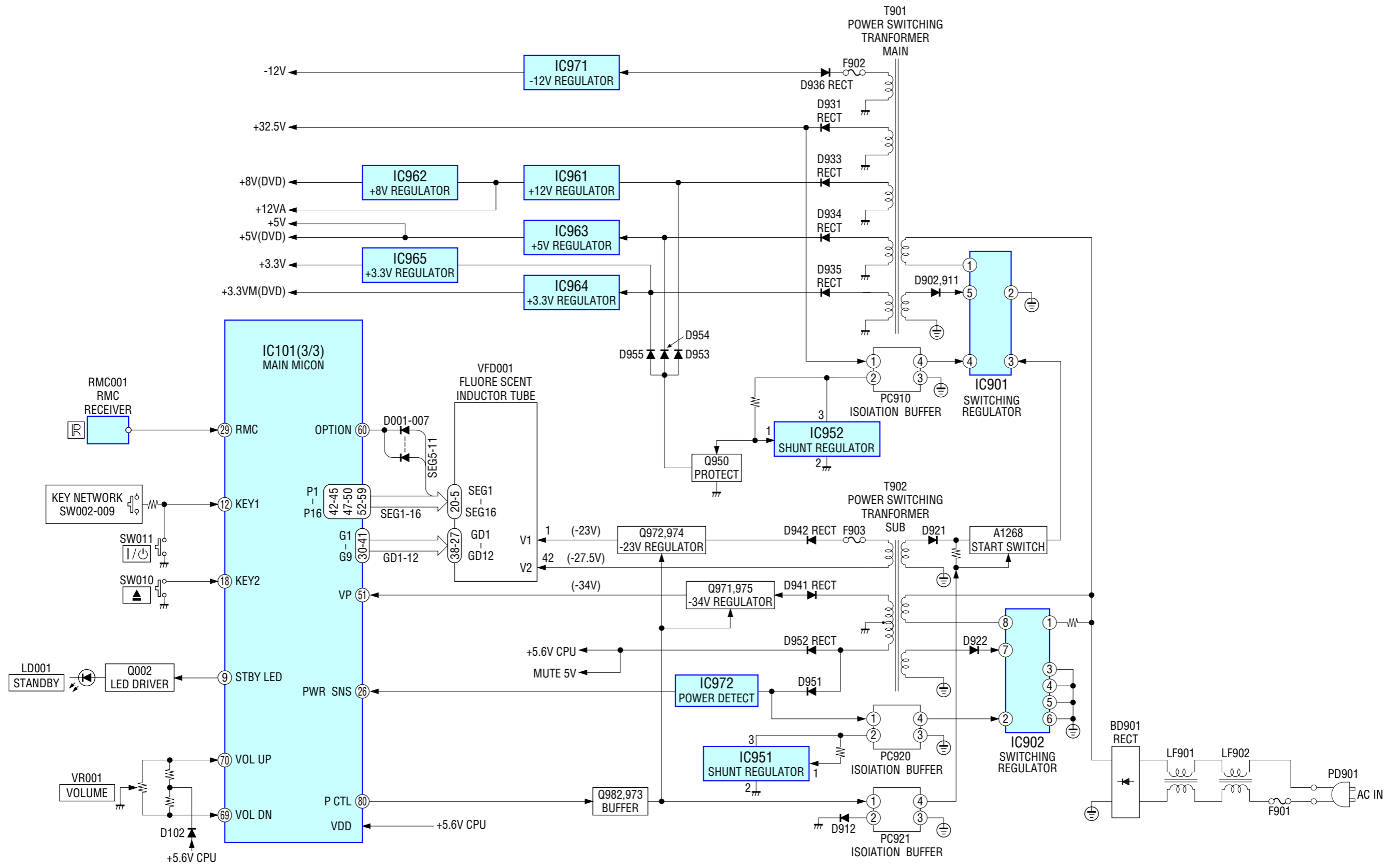

3-6. PRINTED WIRING BOARD – DVD SECTION (SIDE A) –

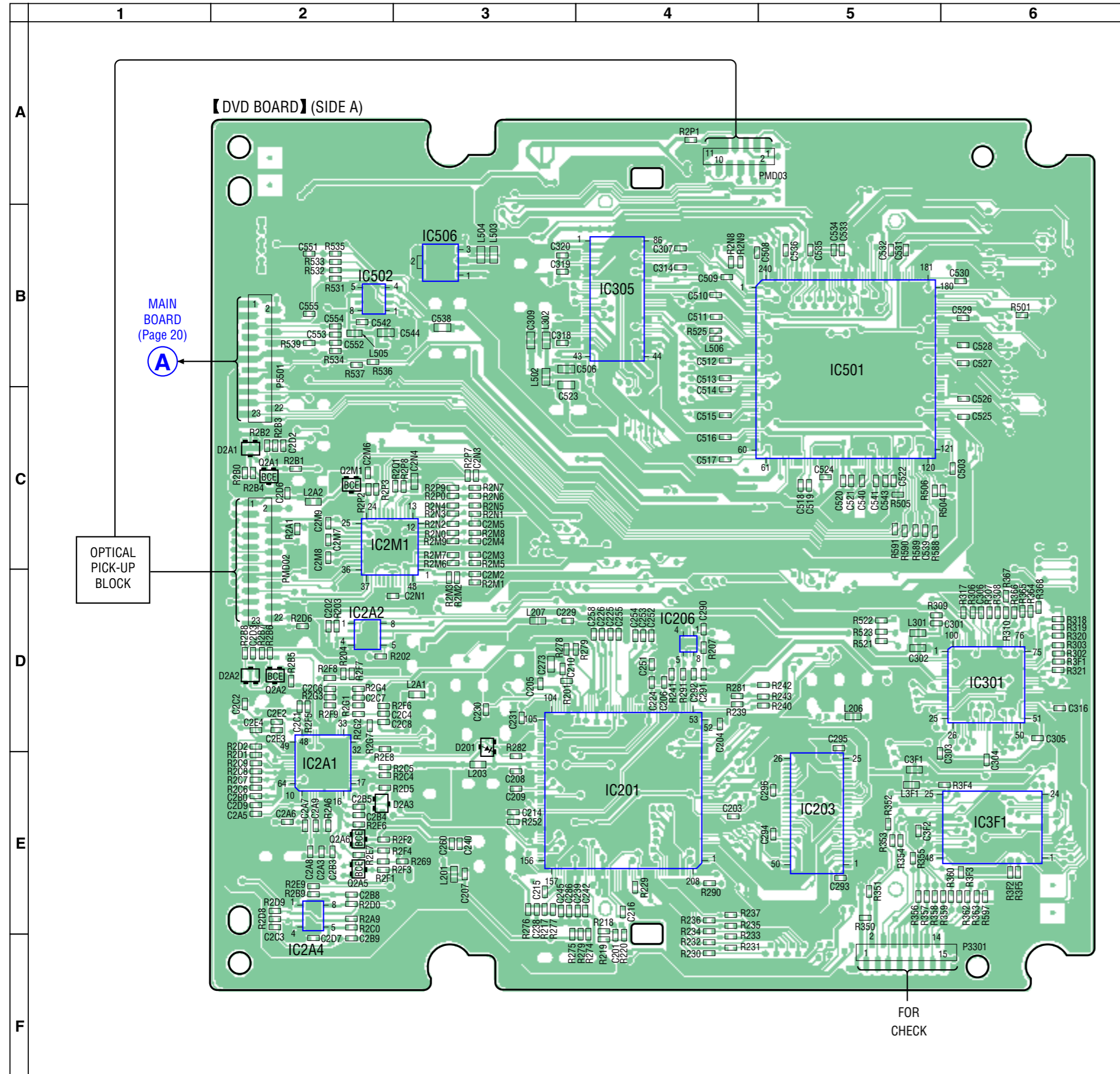

• Semiconductor Location

| Ref. No. | Location |
|----------|----------|
| D201 | D-3 |
| D2A1 | C-2 |
| D2A2 | D-2 |
| D2A3 | E-2 |
| IC201 | E-4 |
| IC203 | E-5 |
| IC206 | D-4 |
| IC2A1 | E-2 |
| IC2A2 | D-2 |
| IC2A4 | E-2 |
| IC2M1 | C-2 |
| IC301 | D-6 |
| IC3F1 | E-6 |
| IC501 | B-5 |
| IC502 | B-2 |
| IC506 | B-3 |
| Q2A1 | C-2 |
| Q2A2 | D-2 |
| Q2A5 | E-2 |
| Q2A6 | E-2 |
| Q2M1 | C-2 |

3-7. PRINTED WIRING BOARD – DVD SECTION (SIDE B) –

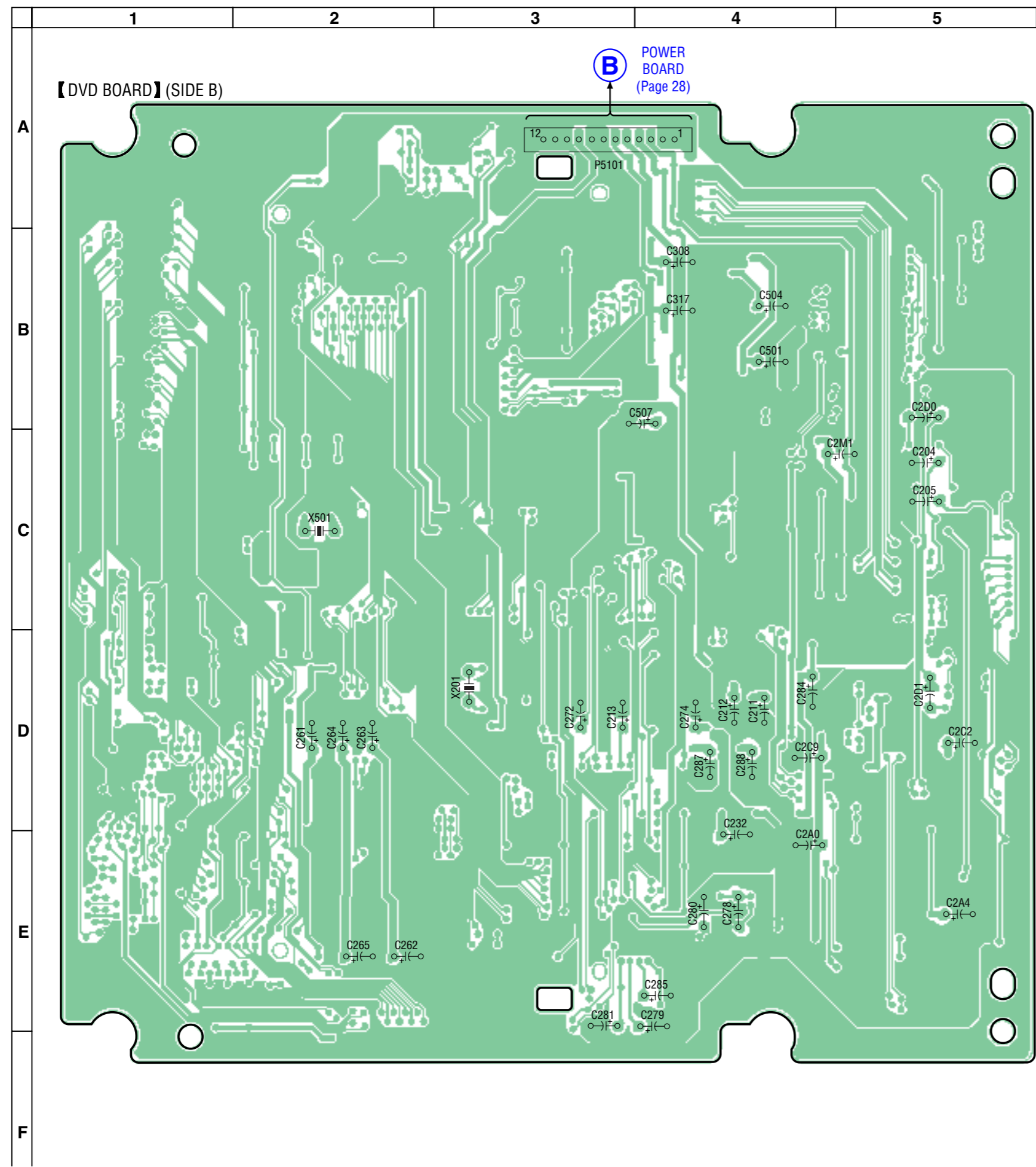

3-8. SCHEMATIC DIAGRAM – DVD SECTION (1/4)–

• See page 30 for waveforms.

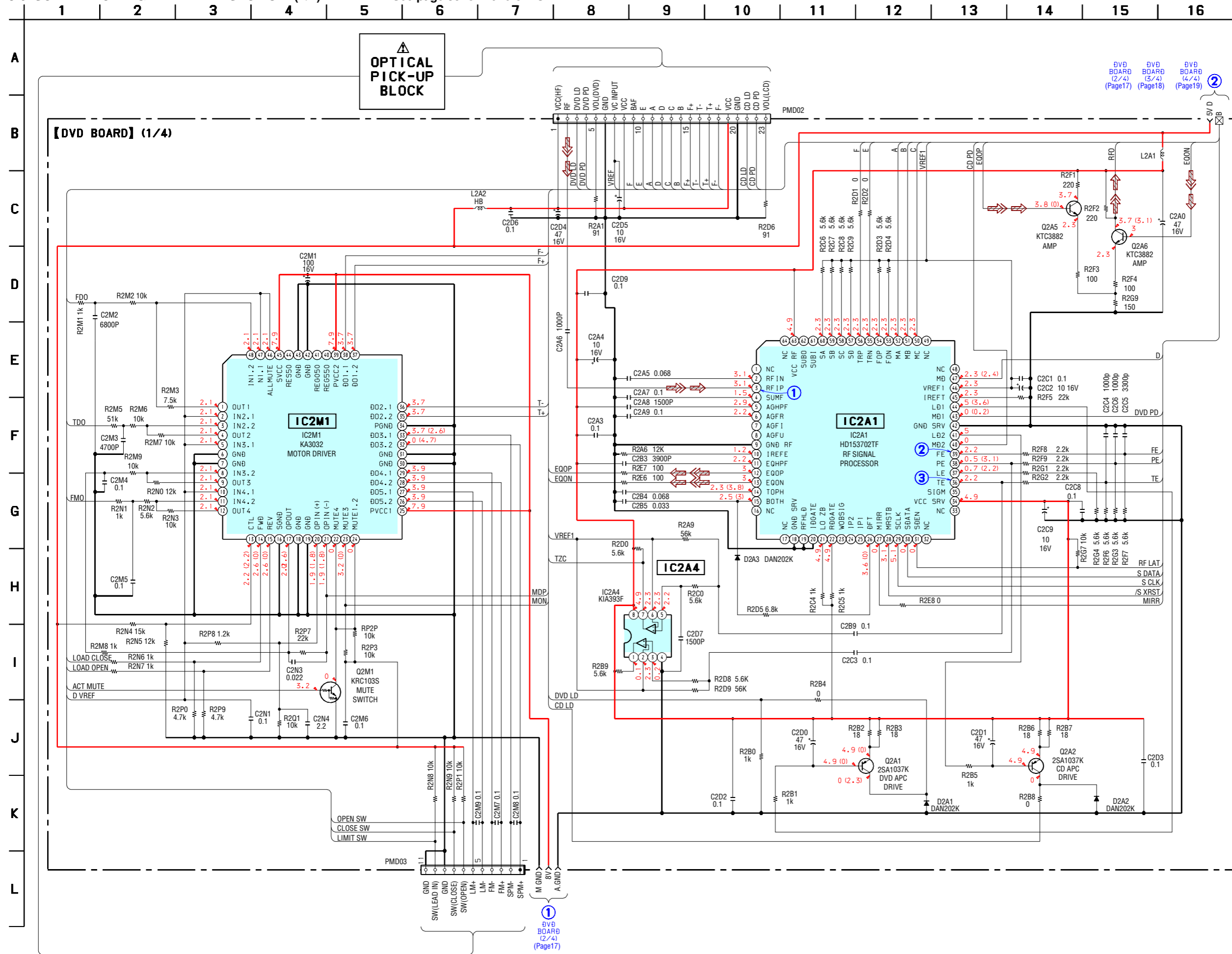

3-9. SCHEMATIC DIAGRAM – DVD SECTION (2/4)–

• See page 30 for waveforms.

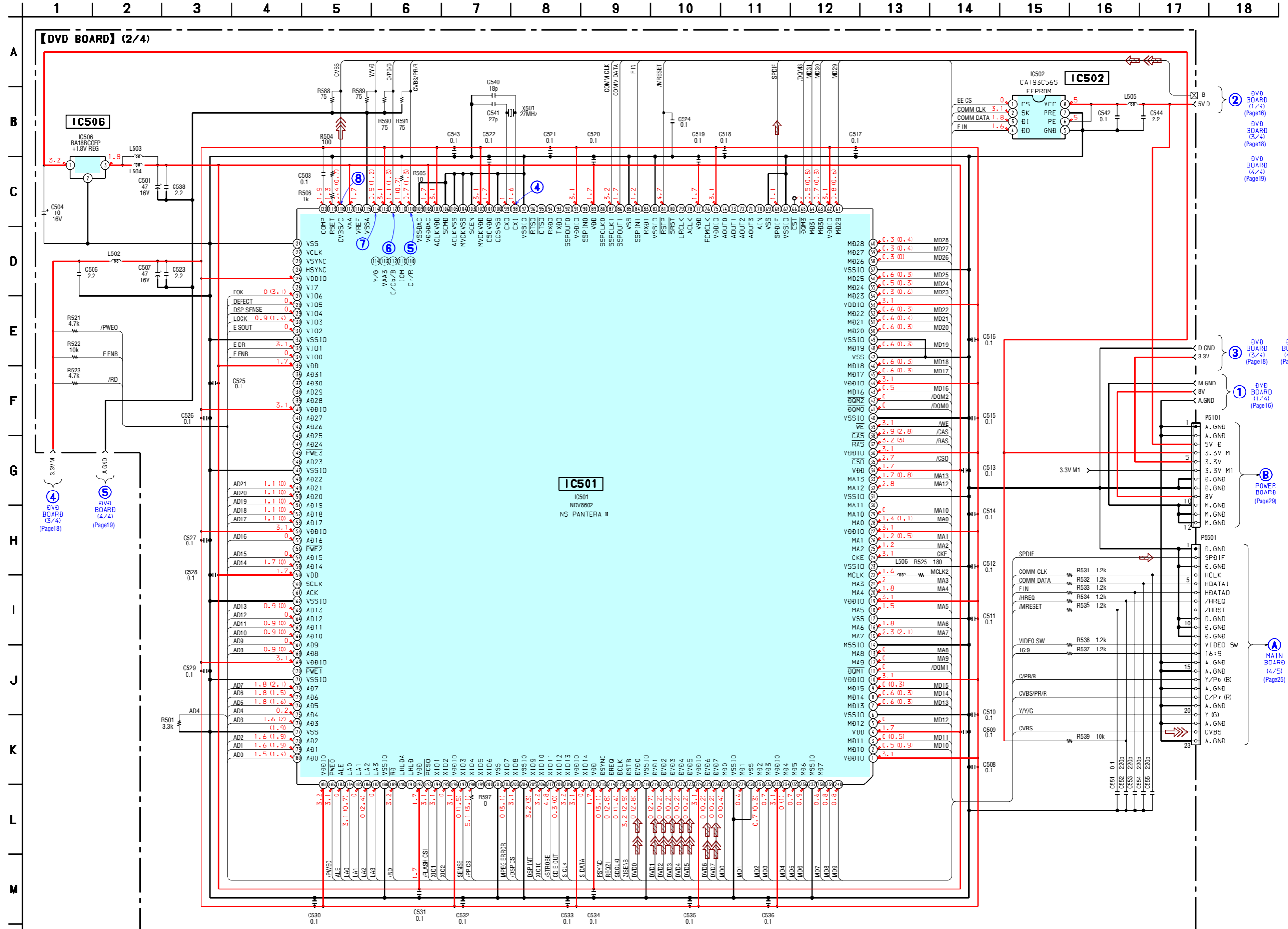

3-10. SCHEMATIC DIAGRAM – DVD SECTION (3/4)–

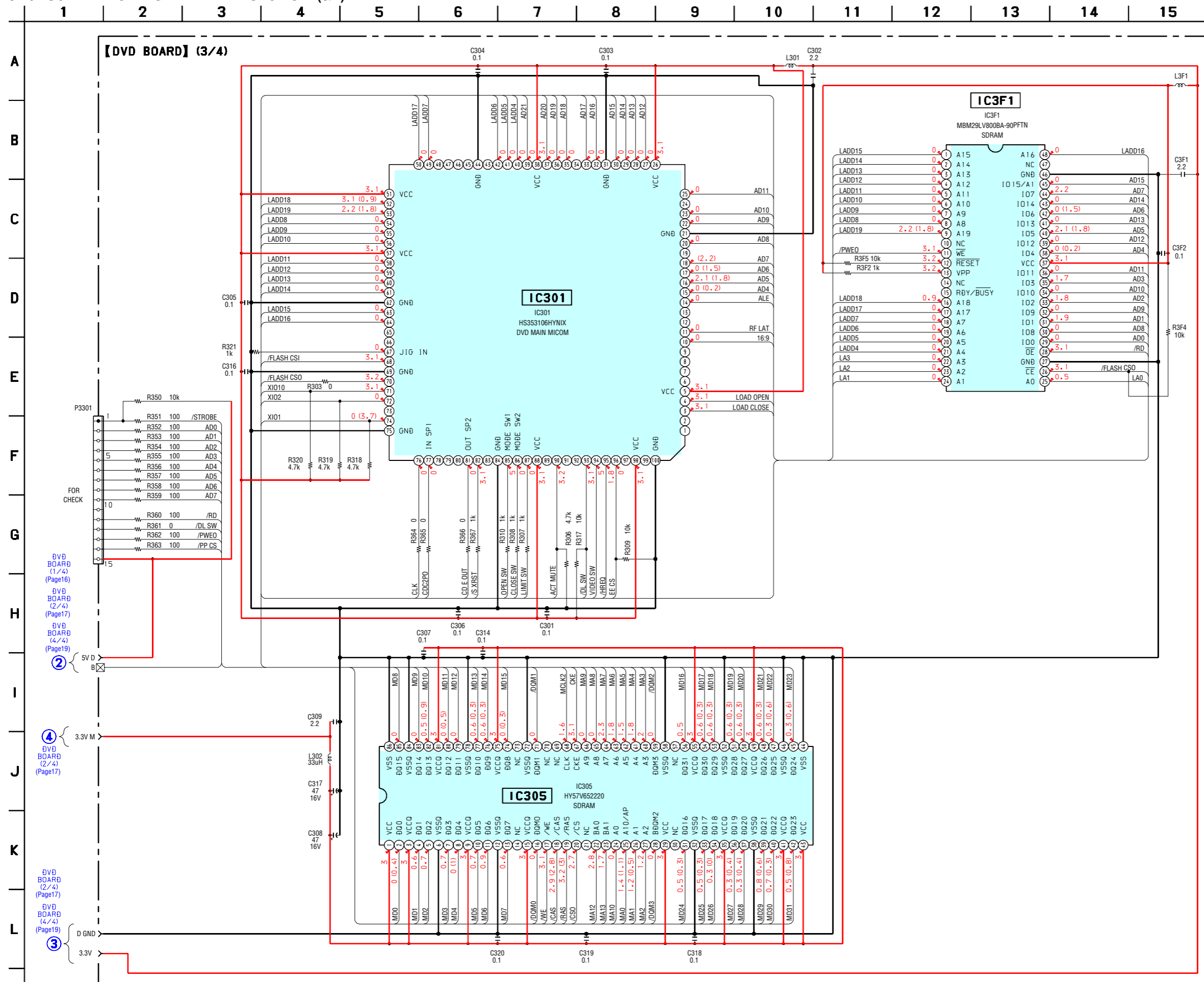

DVD BOARD (1/4) (Page16)

DVD BOARD (2/4) (Page17)

DVD BOARD (4/4) (Page19)

DVD BOARD (2/4) (Page17)

DVD BOARD (4/4) (Page19)

DVD BOARD (2/4) (Page17)

DVD BOARD (4/4) (Page19)

3-11. SCHEMATIC DIAGRAM – DVD SECTION (4/4)–

• See page 30 for waveforms.

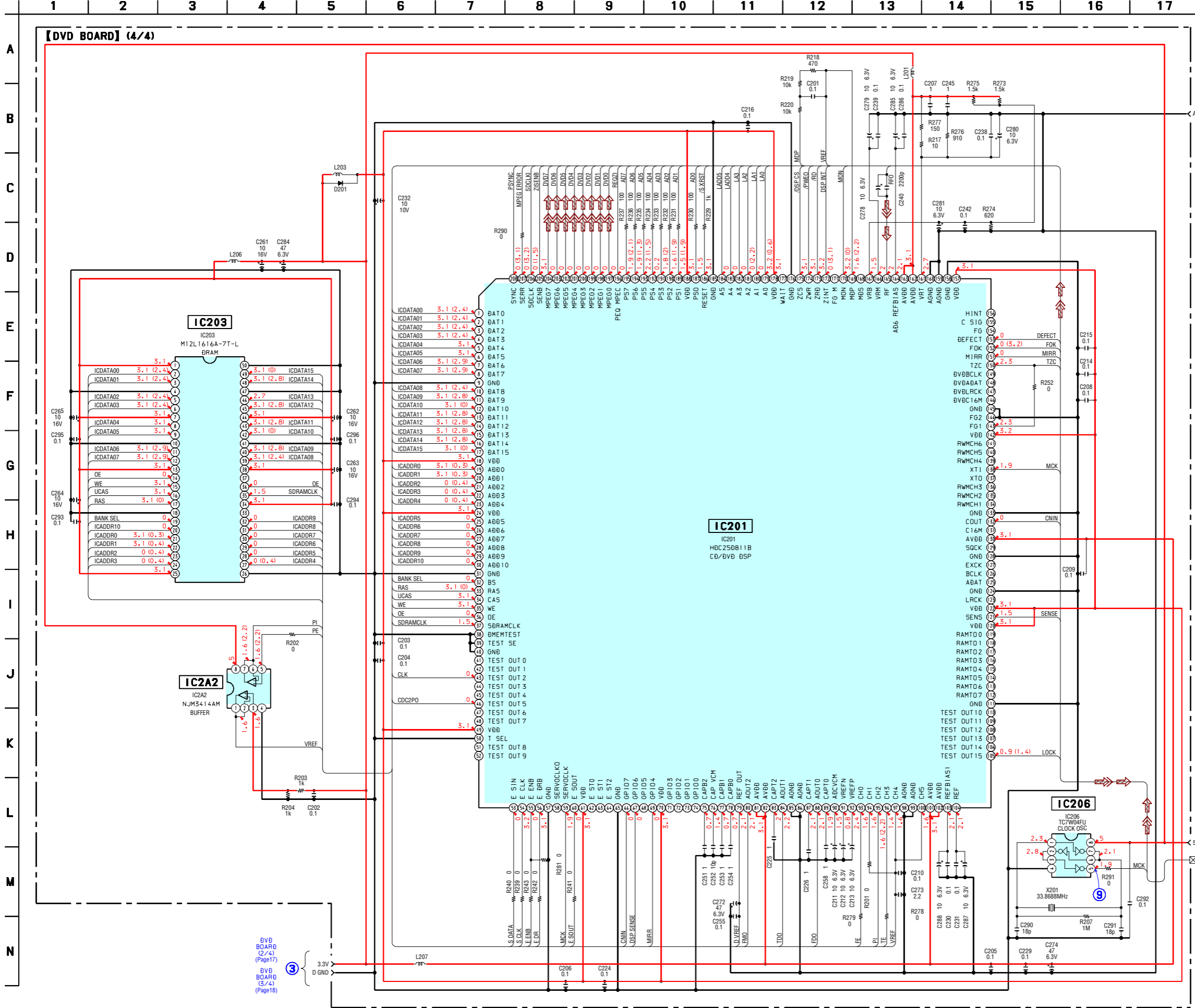

⑤
DVD BOARD (2/4)
(Page17)

②
DVD BOARD (1/4)
(Page16)

③
DVD BOARD (2/4)
(Page17)

④
DVD BOARD (3/4)
(Page18)

3-12. PRINTED WIRING BOARD – MAIN SECTION (SIDE A) –

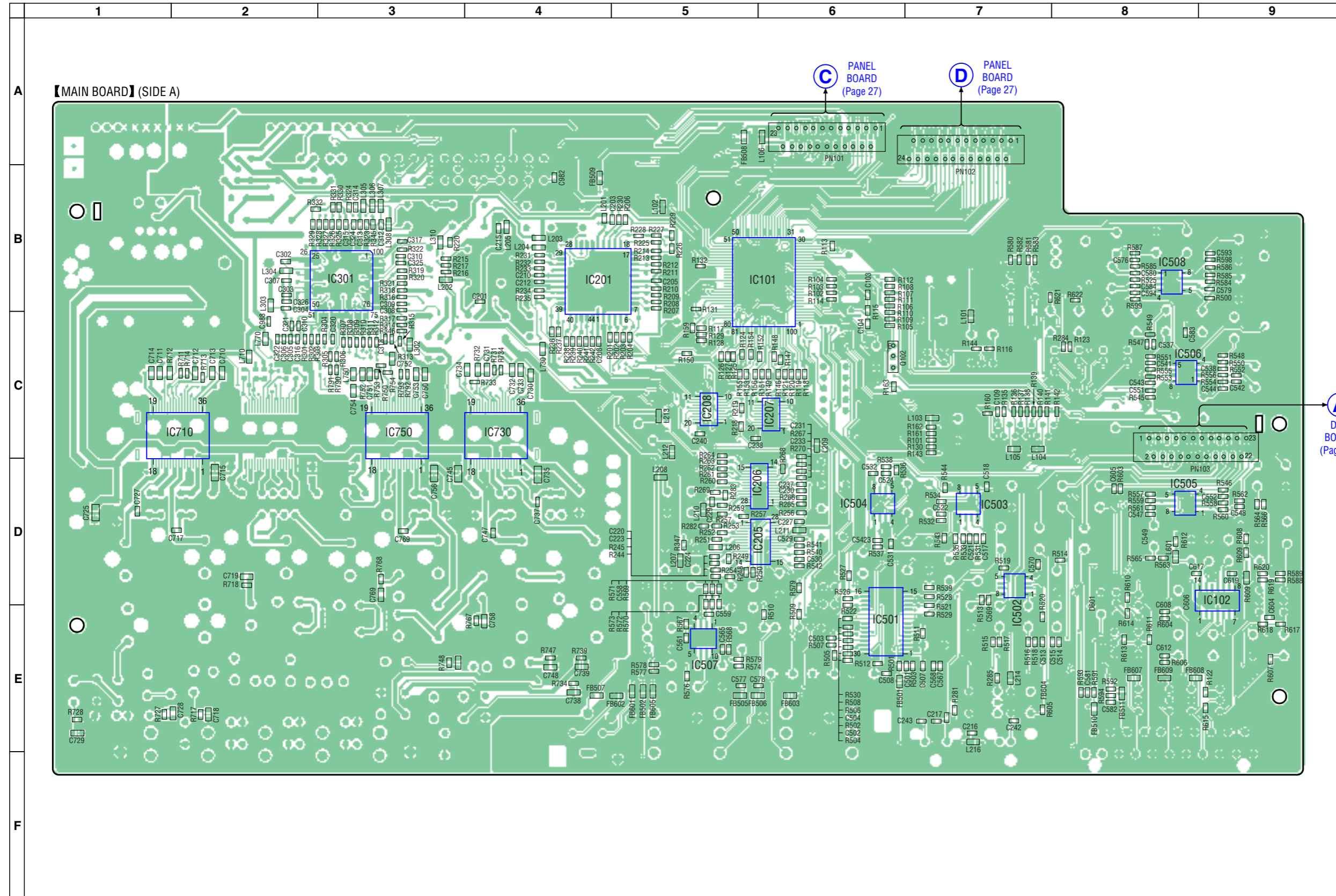

• Semiconductor Location

| Ref. No. | Location |
|----------|----------|
| IC101 | B-6 |
| IC102 | D-9 |
| IC201 | B-4 |
| IC205 | D-5 |
| IC206 | D-5 |
| IC207 | C-6 |
| IC208 | C-5 |
| IC301 | B-3 |
| IC501 | E-6 |
| IC502 | D-7 |
| IC503 | D-7 |
| IC504 | D-6 |
| IC505 | D-8 |
| IC506 | C-8 |
| IC507 | E-5 |
| IC508 | B-8 |
| IC710 | C-2 |
| IC730 | C-4 |
| IC750 | C-3 |
| Q102 | C-6 |

3-13. PRINTED WIRING BOARD – MAIN SECTION (SIDE B) –

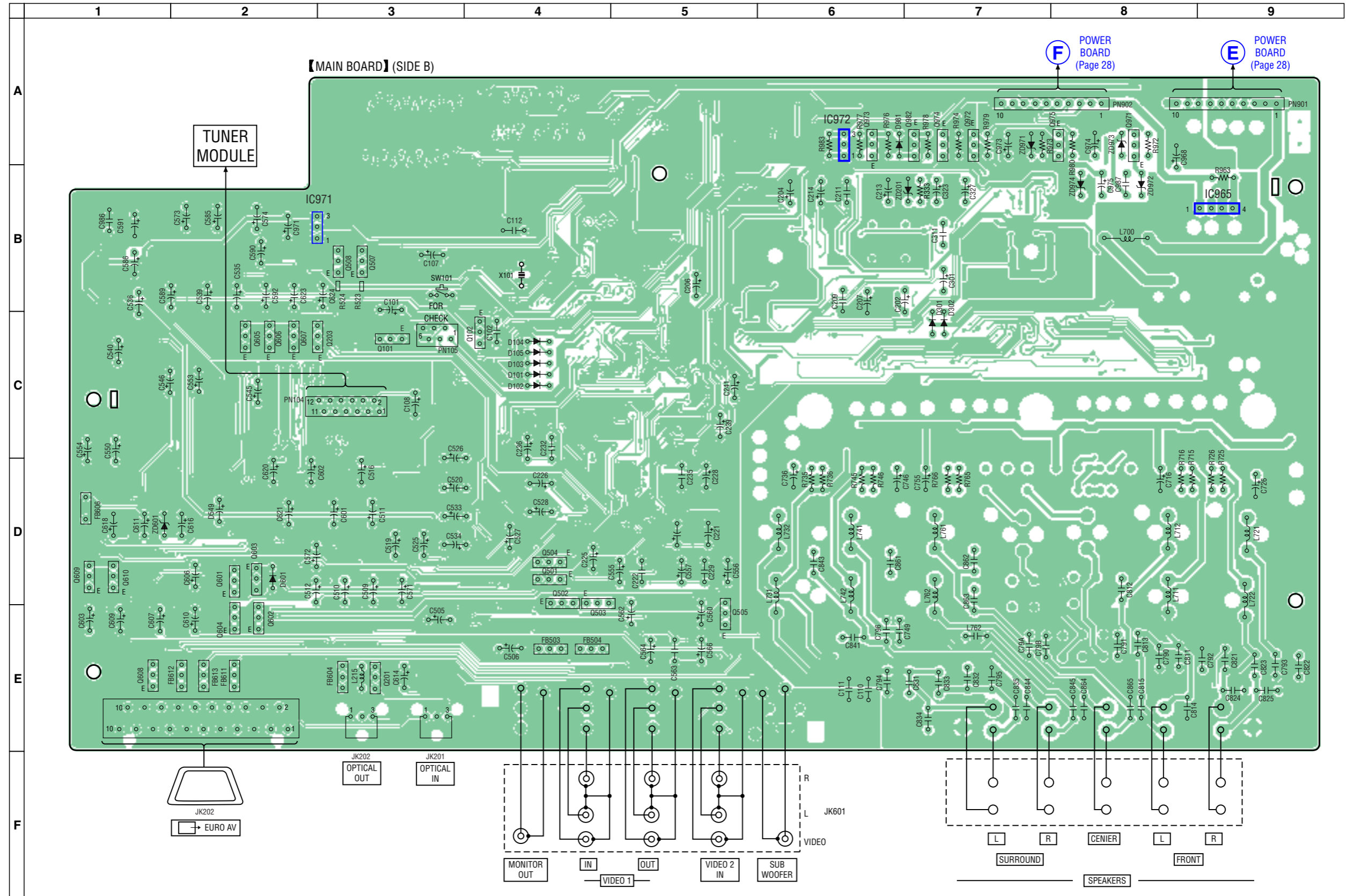

• Semiconductor Location

| Ref. No. | Location |
|----------|----------|
| D101 | C-4 |
| D102 | C-4 |
| D103 | C-4 |
| D104 | C-4 |
| D105 | C-4 |
| D301 | C-7 |
| D302 | C-7 |
| D601 | D-2 |
| D981 | A-6 |
| IC965 | B-9 |
| IC971 | B-2 |
| IC972 | A-6 |
| Q101 | C-3 |
| Q203 | C-3 |
| Q501 | D-4 |
| Q502 | D-4 |
| Q503 | D-4 |
| Q504 | D-4 |
| Q507 | B-3 |
| Q508 | B-3 |
| Q601 | D-2 |
| Q602 | E-2 |
| Q603 | D-2 |
| Q604 | E-2 |
| Q605 | C-2 |
| Q606 | C-2 |
| Q607 | C-2 |
| Q608 | E-1 |
| Q609 | D-1 |
| Q610 | D-1 |
| Q971 | A-8 |
| Q972 | A-7 |
| Q974 | A-7 |
| Q975 | A-8 |
| Q982 | A-7 |
| ZD201 | B-7 |
| ZD601 | D-1 |
| ZD971 | A-7 |
| ZD972 | B-8 |
| ZD973 | A-8 |
| ZD974 | B-8 |

3-14. SCHEMATIC DIAGRAM – MAIN SECTION (1/5) –

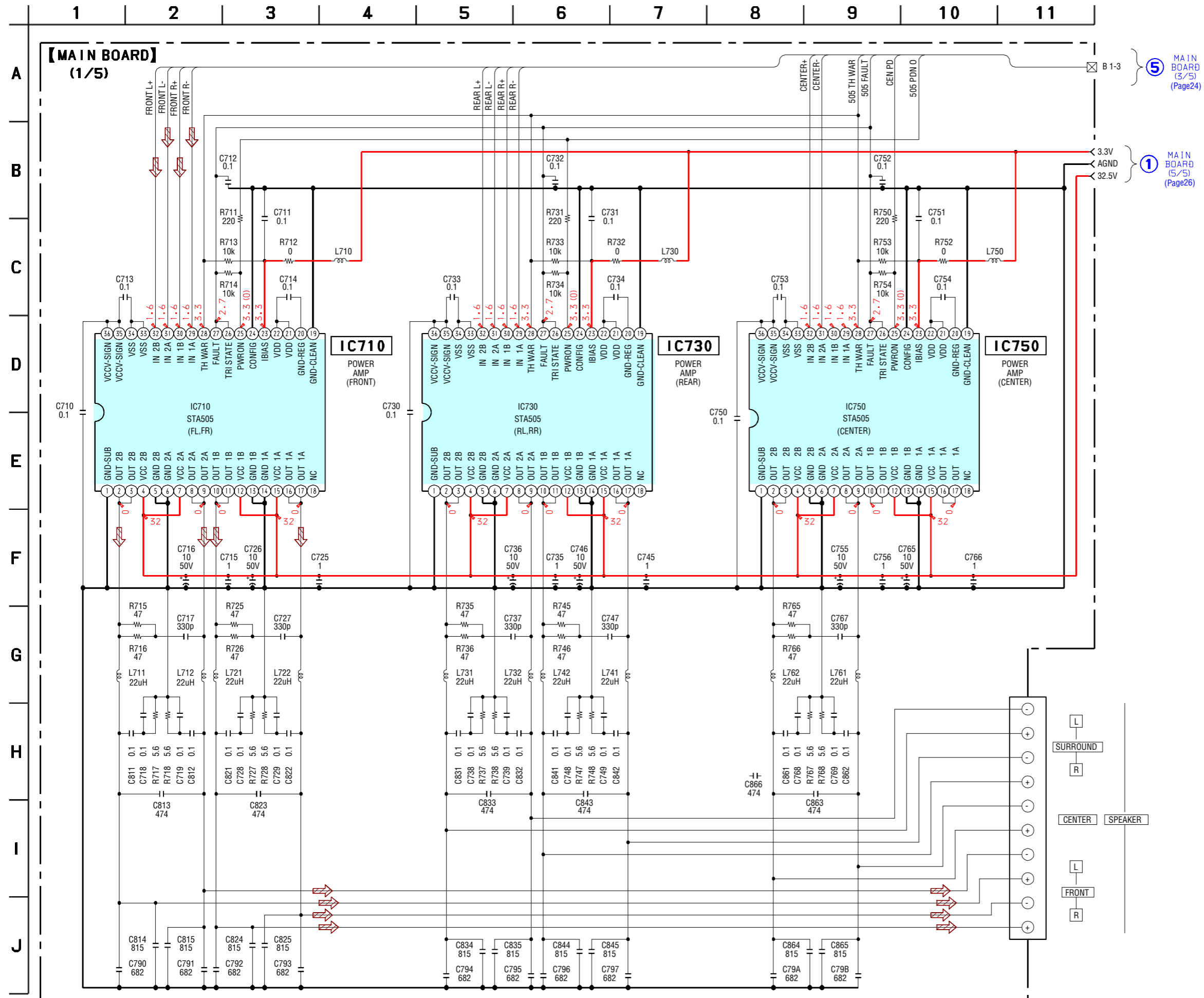

5 MAIN BOARD (3/5) (Page24)

1 MAIN BOARD (5/5) (Page26)

3-15. SCHEMATIC DIAGRAM – MAIN SECTION (2/5) –

• See page 30 for waveforms.

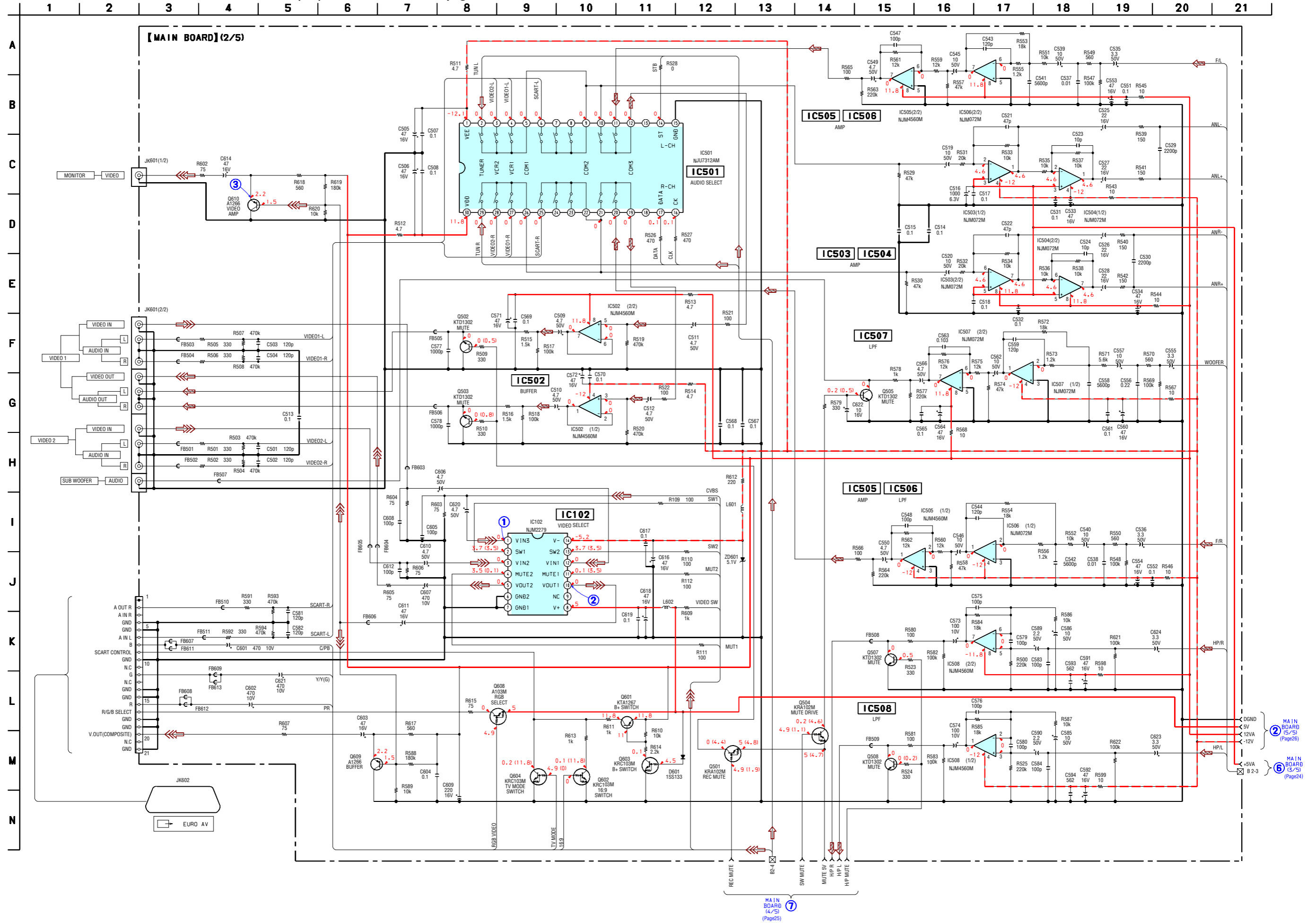

3-16. SCHEMATIC DIAGRAM – MAIN SECTION (3/5) –

• See page 30 for waveforms.

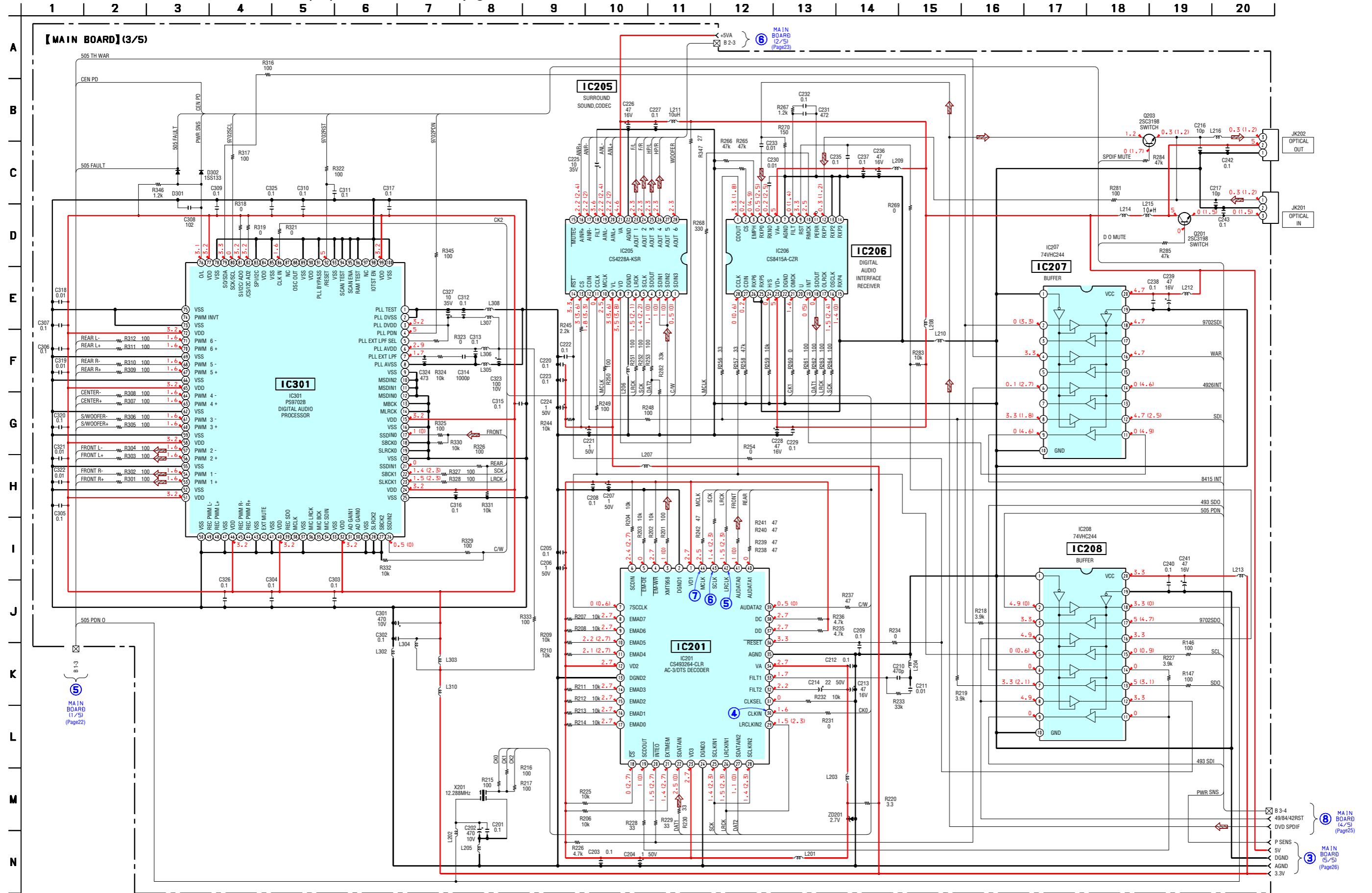

3-17. SCHEMATIC DIAGRAM – MAIN SECTION (4/5) –

• See page 30 for waveforms.

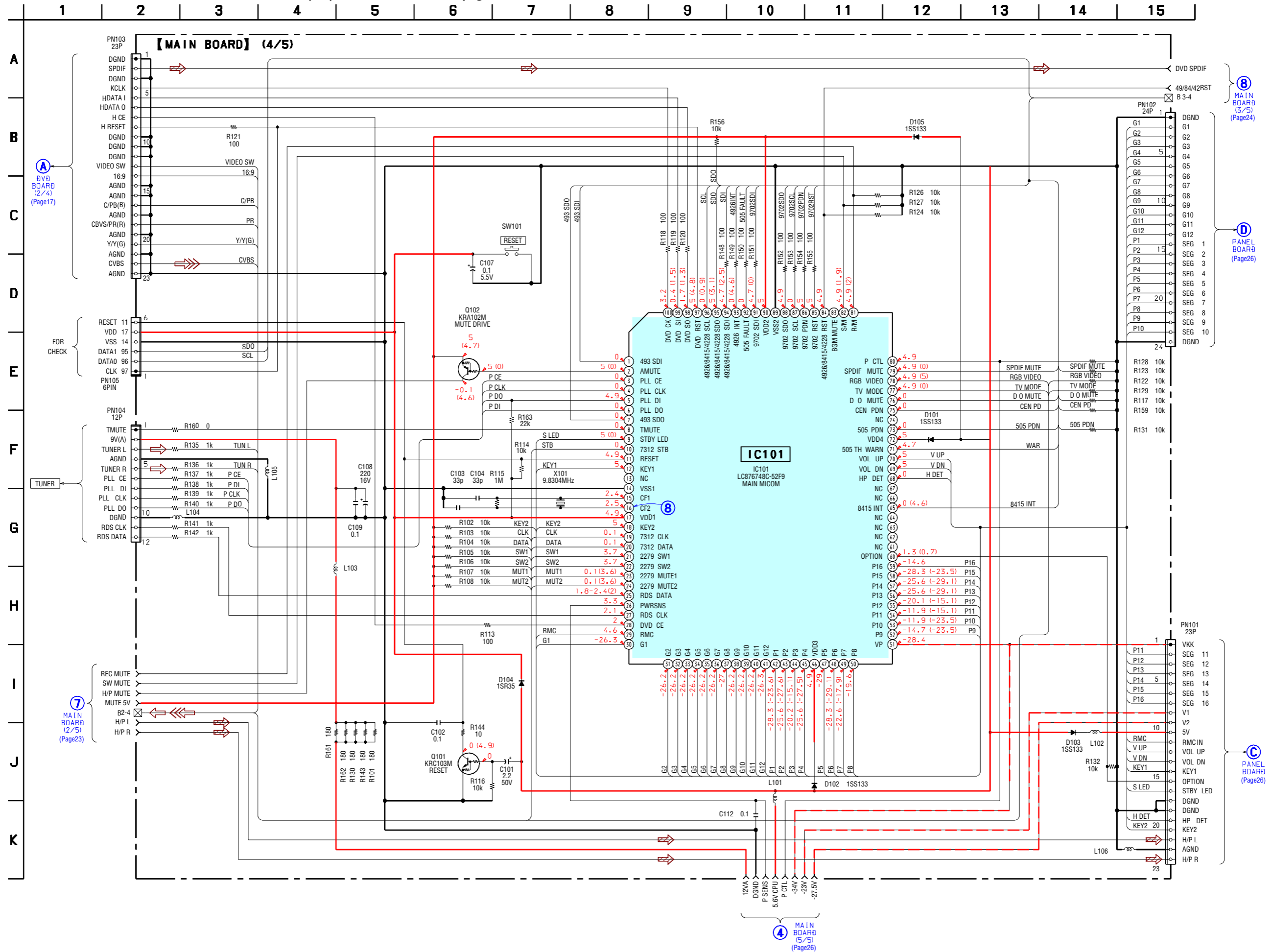

3-18. SCHEMATIC DIAGRAM – MAIN SECTION (5/5) –

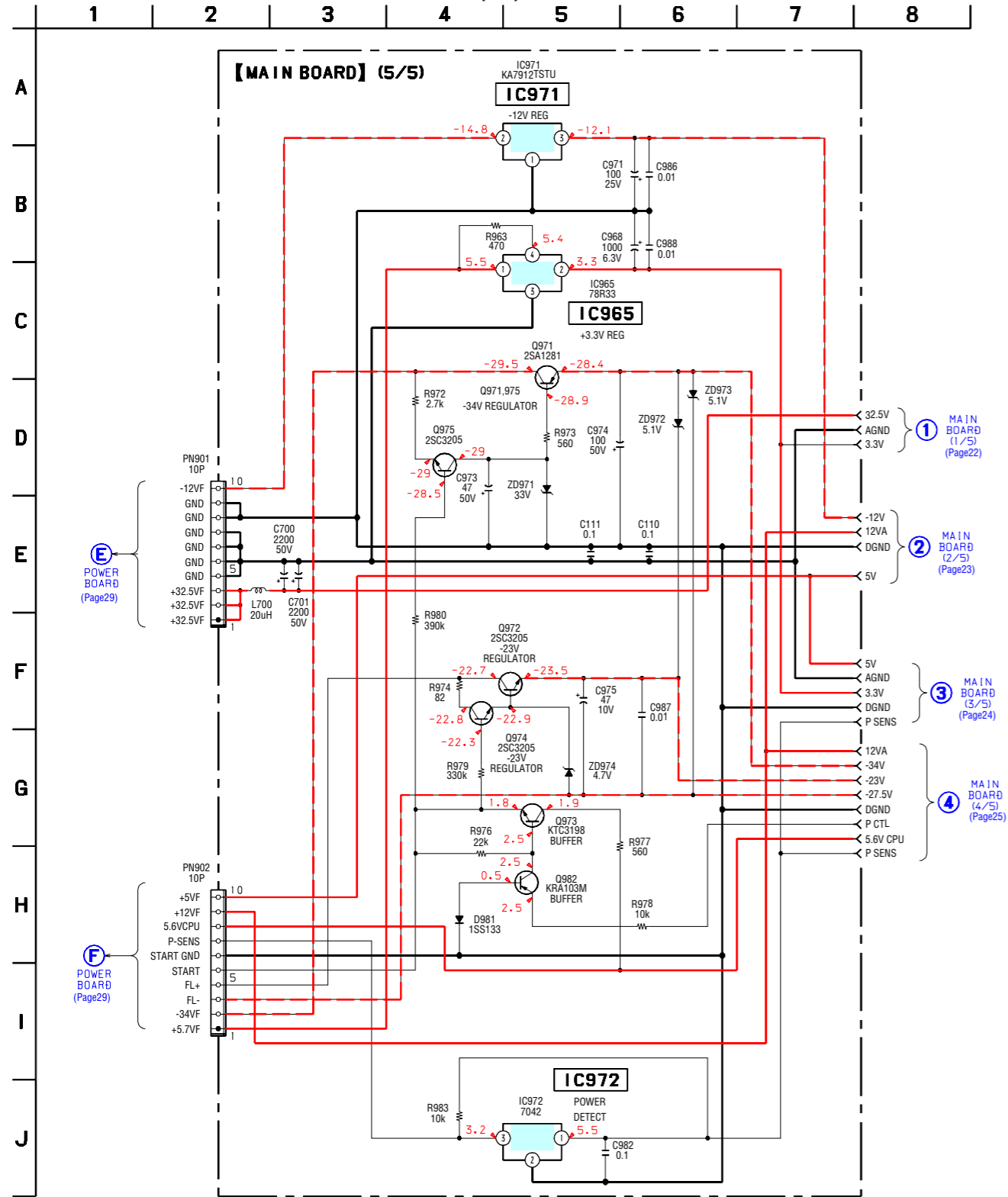

3-19. SCHEMATIC DIAGRAM – PANEL SECTION –

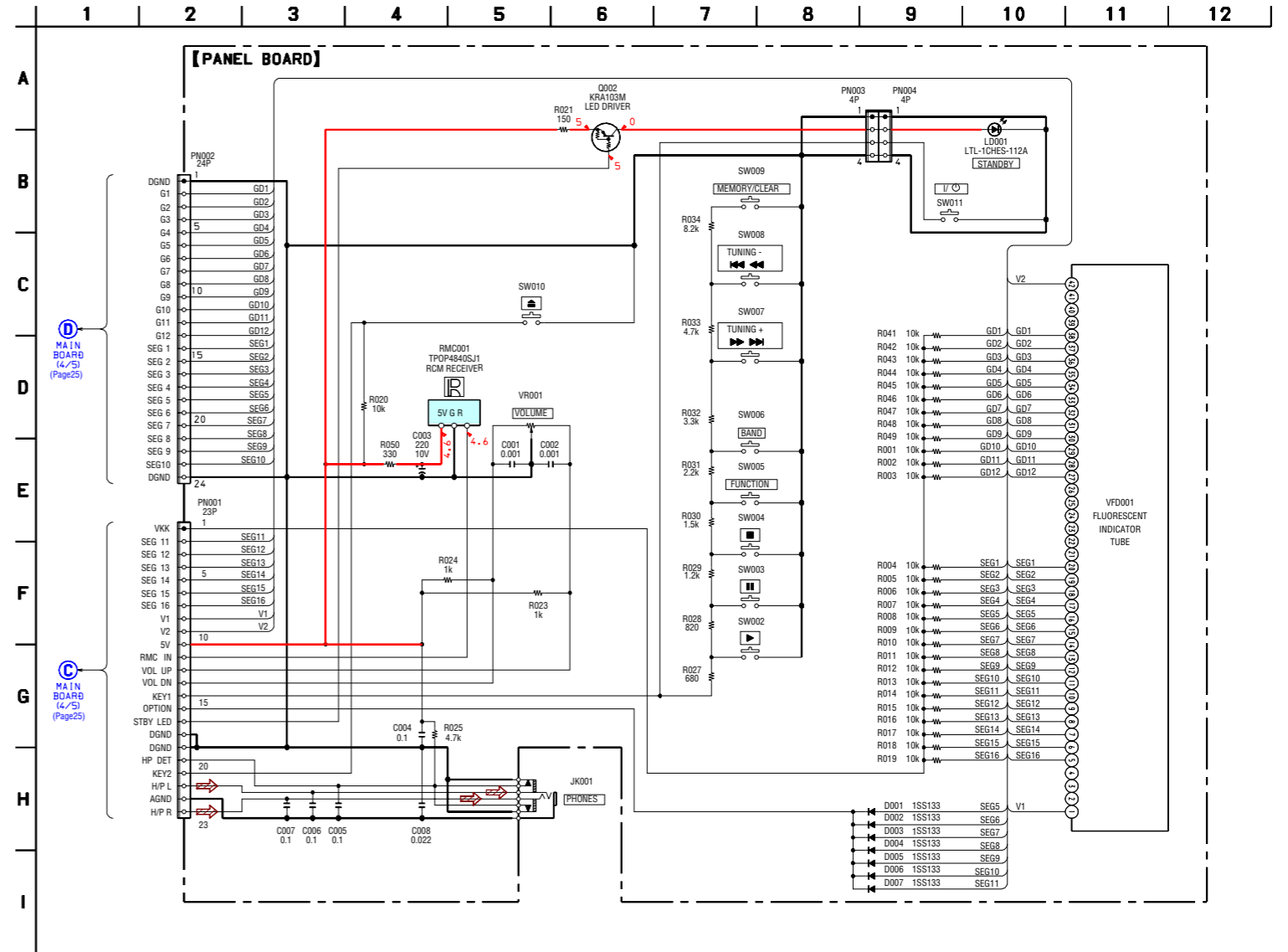

3-20. PRINTED WIRING BOARD – PANEL SECTION –

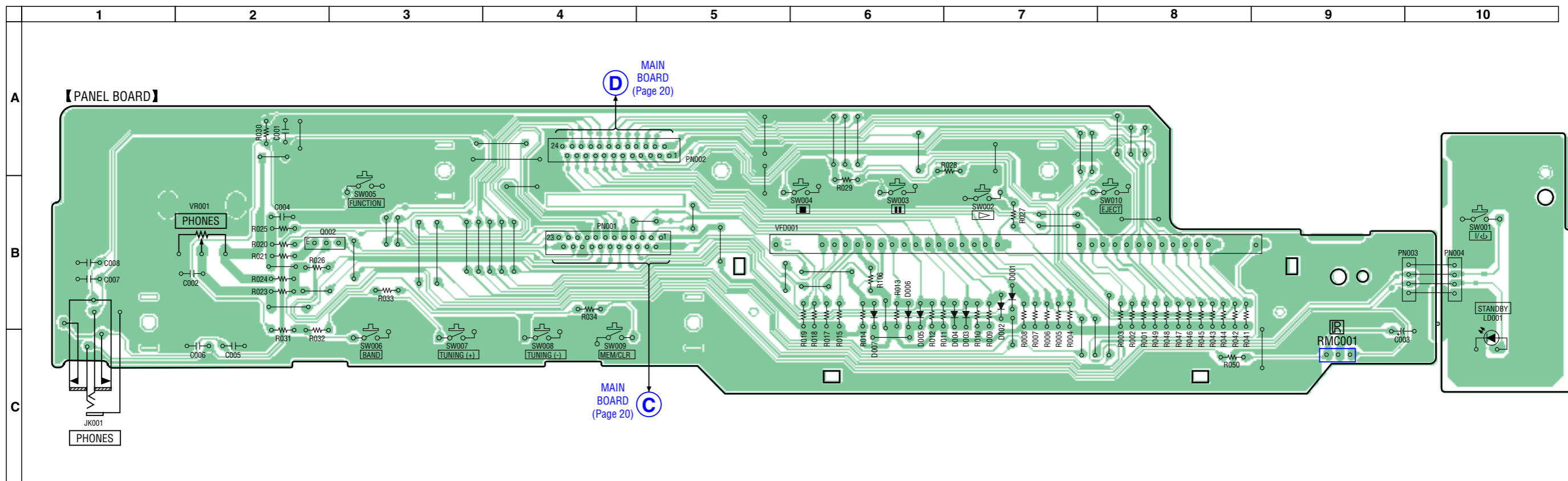

• Semiconductor Location

| Ref. No. | Location |
|----------|----------|
| D001 | B-7 |
| D002 | B-7 |
| D003 | B-7 |
| D004 | B-7 |
| D005 | B-6 |
| D006 | B-6 |
| D007 | B-6 |

3-21. PRINTED WIRING BOARD – POWER SECTION –

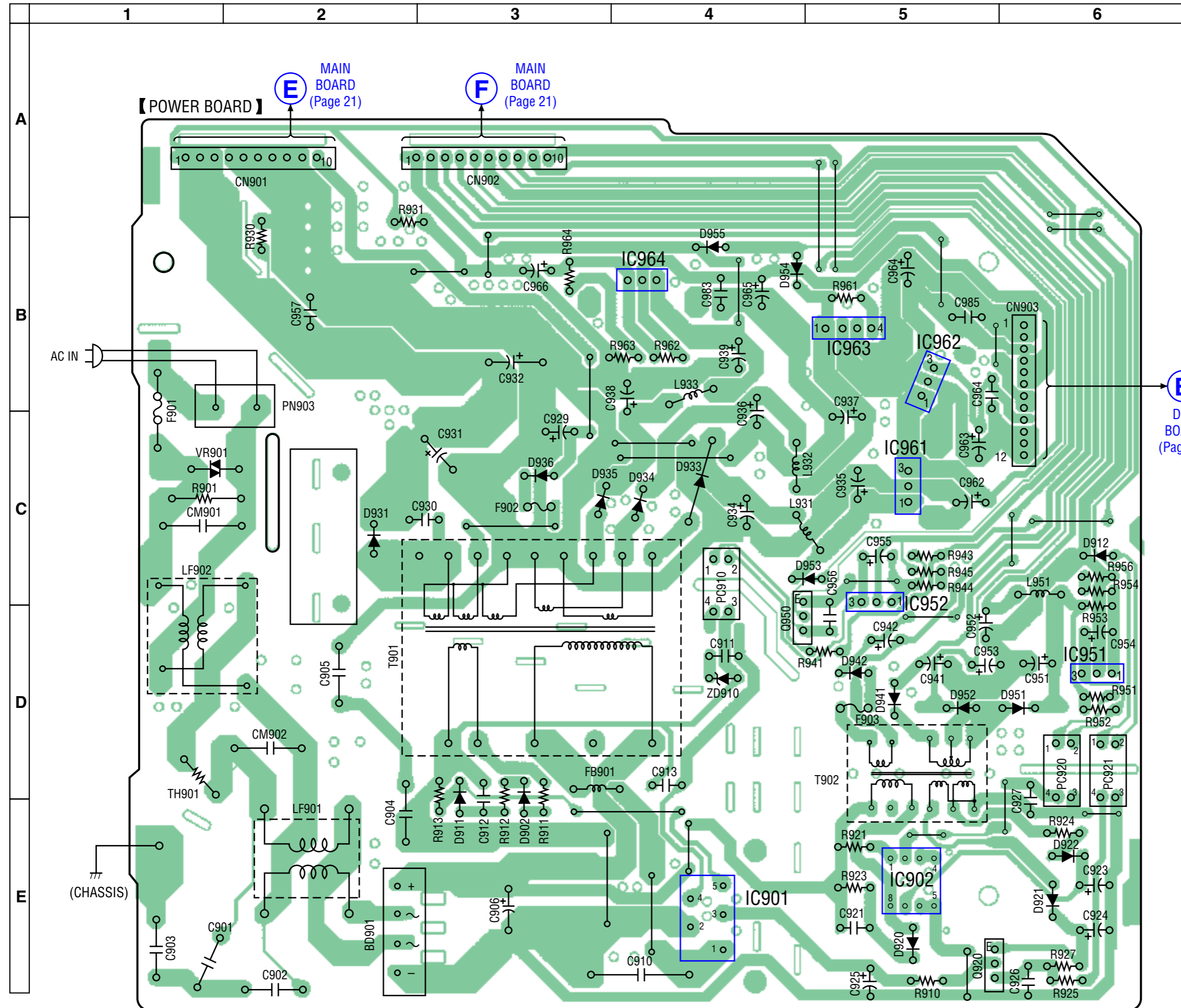

• Semiconductor Location

| Ref. No. | Location |
|----------|----------|
| D902 | E-3 |
| D911 | E-3 |
| D912 | C-6 |
| D920 | E-5 |
| D921 | E-6 |
| D922 | E-6 |
| D931 | C-2 |
| D933 | C-4 |
| D934 | C-4 |
| D935 | C-3 |
| D936 | C-3 |
| D941 | D-5 |
| D942 | D-5 |
| D951 | D-6 |
| D952 | D-5 |
| D953 | C-5 |
| D954 | B-4 |
| D955 | B-4 |
| IC901 | E-4 |
| IC902 | E-5 |
| IC951 | D-6 |
| IC952 | C-5 |
| IC961 | C-5 |
| IC962 | B-5 |
| IC963 | B-5 |
| IC964 | B-4 |
| Q920 | E-5 |
| Q950 | D-5 |
| VR901 | C-1 |
| ZD910 | D-4 |

3-22. SCHEMATIC DIAGRAM – POWER SECTION –

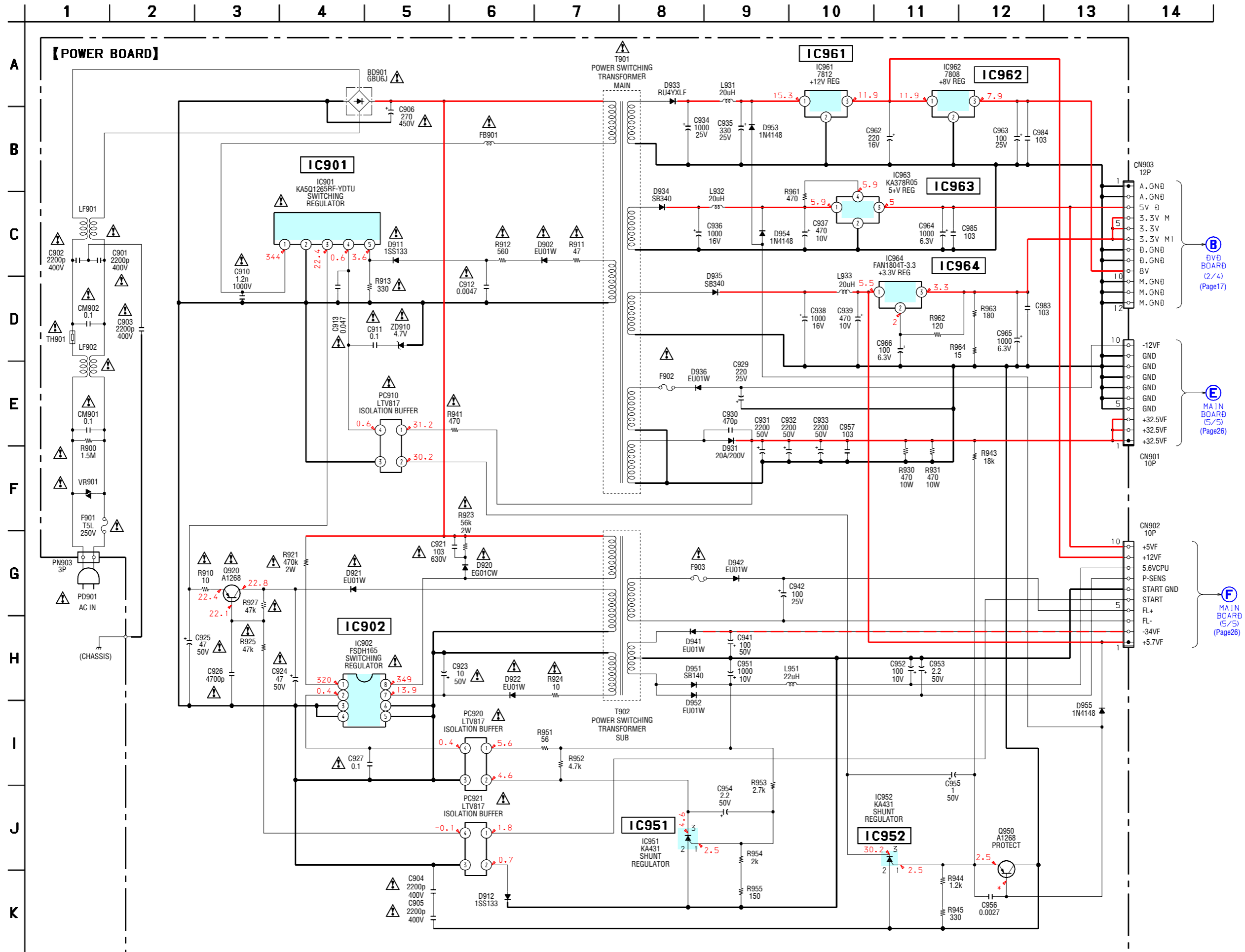

• WAVEFORMS

– DVD BOARD –

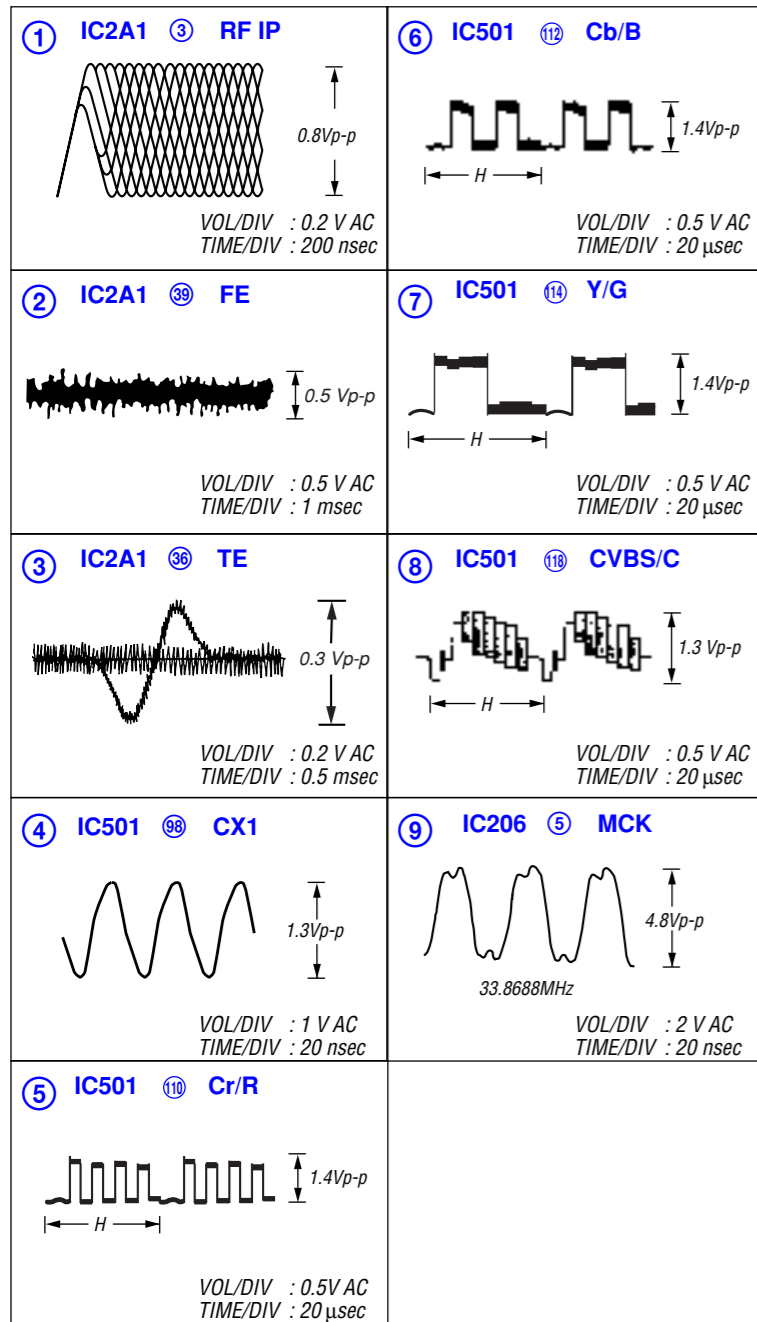

– MAIN BOARD –

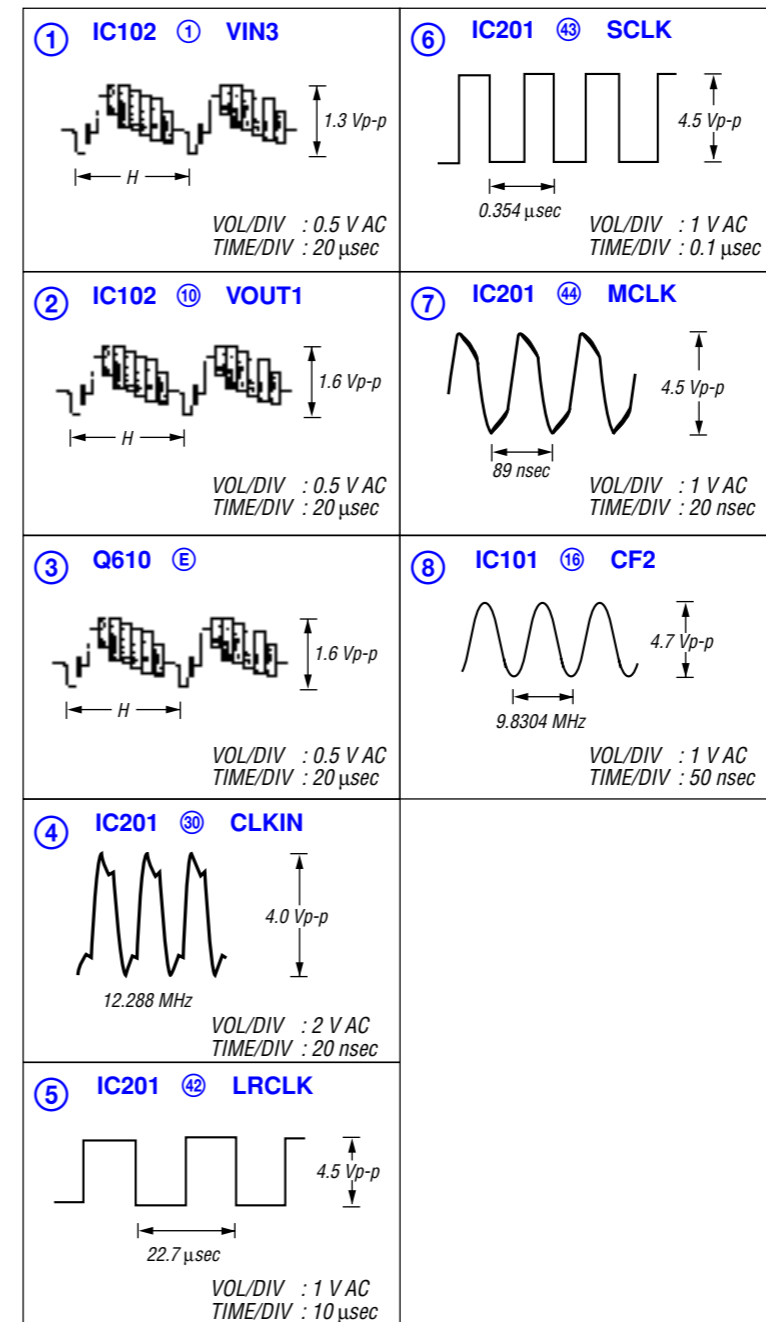

SECTION 4 EXPLODED VIEWS

NOTE:

- -XX, -X mean standardized parts, so they may have some difference from the original one.
- Items marked "*" are not stocked since they are seldom required for routine service. Some delay should be anticipated when ordering these items.
- The mechanical parts with no reference number in the exploded views are not supplied.
- Accessories are given in the last of this parts list.

The components identified by mark Δ or dotted line with mark Δ are critical for safety. Replace only with part number specified.

4-1. CHASSIS SECTION

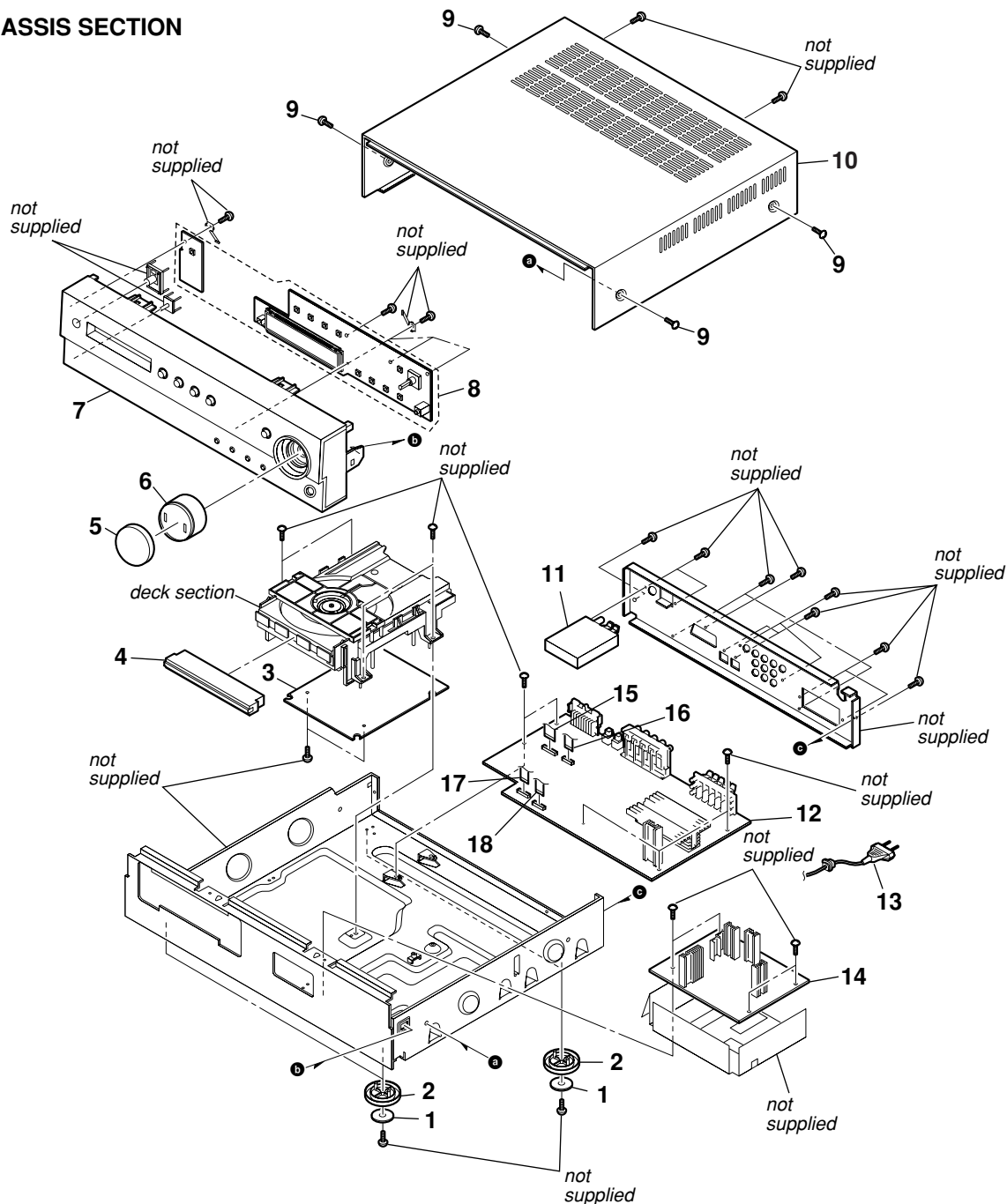

| Ref. No. | Part No. | Description | Remark | Ref. No. | Part No. | Description | Remark |
|----------|--------------|------------------|--------|-------------|--------------|--|--------|
| 1 | 9-885-054-40 | RUBBER FOOT | | 11 | 9-885-054-55 | TUNER | |
| 2 | 9-885-054-39 | HOLDER (FOOT) | | 12 | 9-885-054-53 | MAIN MOUNT | |
| 3 | 9-885-054-49 | DVD MOUNT | | Δ 13 | 9-885-054-41 | POWER CORD (AEP) | |
| 4 | 9-885-054-36 | DOOR ASSY | | Δ 13 | 9-885-054-42 | POWER CORD (UK) | |
| 5 | 9-885-054-38 | KNOB VOLUME | | 14 | 9-885-054-54 | POWER MOUNT | |
| 6 | 9-885-054-37 | HOLDER (VOLUME) | | 15 | 9-885-054-59 | CABLE, FLEXIBLE FLAT (23 CORE) (120mm) | |
| 7 | 9-885-054-33 | FRONT PANEL ASSY | | 16 | 9-885-054-56 | CABLE, FLEXIBLE FLAT (12 CORE) | |
| 8 | 9-885-054-52 | PANEL MOUNT | | 17 | 9-885-054-58 | CABLE, FLEXIBLE FLAT (24 CORE) | |
| 9 | 9-885-054-51 | SCREW 3X10 | | 18 | 9-885-054-57 | CABLE, FLEXIBLE FLAT (23 CORE) (310mm) | |
| 10 | 9-885-054-32 | CASE TOP | | | | | |

4-2. DECK SECTION

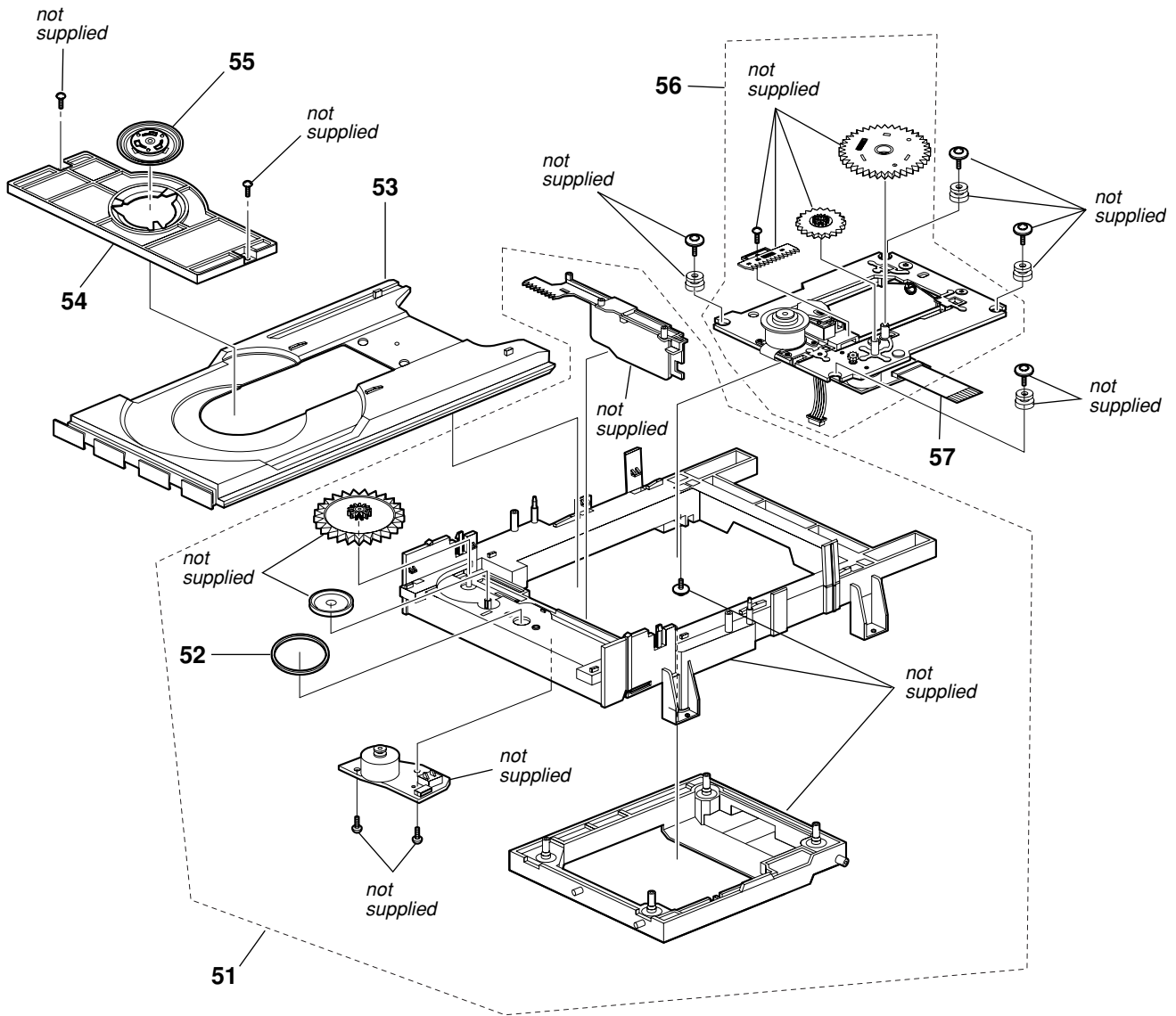

The components identified by mark Δ or dotted line with mark Δ are critical for safety. Replace only with part number specified.

| Ref. No. | Part No. | Description | Remark | Ref. No. | Part No. | Description | Remark |
|----------|--------------|--------------|--------|----------|--------------|--------------------------------|--------|
| 51 | 9-885-054-45 | BASE ASSY | | 55 | 9-885-054-47 | CLAMP ASSY | |
| 52 | 9-885-054-50 | BELT LOADING | | Δ 56 | 9-885-054-44 | PU BASE ASSY | |
| 53 | 9-885-054-46 | TRAY | | 57 | 9-885-054-60 | CABLE, FLEXIBLE FLAT (11 CORE) | |
| 54 | 9-885-054-48 | HOLDER CLAMP | | | | | |

SECTION 5 ELECTRICAL PARTS LIST

DVD

PANEL

MAIN

NOTE:

- Due to standardization, replacements in the parts list may be different from the parts specified in the diagrams or the components used on the set.
- -XX, -X mean standardized parts, so they may have some difference from the original one.
- Items marked "*" are not stocked since they are seldom required for routine service. Some delay should be anticipated when ordering these items.
- CAPACITORS:
uF: μ F

- RESISTORS
All resistors are in ohms.
METAL: metal-film resistor
METAL OXIDE: Metal Oxide-film resistor
F: nonflammable
- COILS
uH: μ H
- SEMICONDUCTORS
In each case, u: μ , for example:
uA...: μ A..., uPA..., μ PA...,
uPB..., μ PB..., uPC..., μ PC...,
uPD..., μ PD...

The components identified by mark Δ or dotted line with mark Δ are critical for safety. Replace only with part number specified.

When indicating parts by reference number, please include the board name.

| Ref. No. | Part No. | Description | Remarks | Ref. No. | Part No. | Description | Remarks |
|----------|--------------|--------------------------------|---------|----------|--------------|--------------------------------|---------|
| | 9-885-054-49 | DVD MOUNT ***** | | | 9-885-054-53 | MAIN MOUNT ***** | |
| | | < IC > | | | | < CAPACITOR > | |
| IC201 | 9-885-054-65 | IC HDC25D811B | | C107 | 9-885-054-77 | ELECT 0.1F | 5.5V |
| IC203 | 9-885-054-66 | IC M12L1616A-7T-L | | C715 | 9-885-054-78 | CERAMIC CHIP 1uF | 50V |
| IC301 | 9-885-054-70 | IC HS353106HYNIX | | C725 | 9-885-054-78 | CERAMIC CHIP 1uF | 50V |
| IC501 | 9-885-054-72 | IC NDV8602 | | C735 | 9-885-054-78 | CERAMIC CHIP 1uF | 50V |
| IC502 | 9-885-054-73 | IC CAT93C56S | | C745 | 9-885-054-78 | CERAMIC CHIP 1uF | 50V |
| IC2A1 | 9-885-054-67 | IC HD153702TF | | C756 | 9-885-054-78 | CERAMIC CHIP 1uF | 50V |
| IC2A4 | 9-885-054-68 | IC KIA393F | | | | < IC > | |
| IC2M1 | 9-885-054-69 | IC KA3032 | | IC101 | 9-885-054-82 | IC LC876748C-52F9 | |
| IC3F1 | 9-885-054-71 | IC MBM29LV800BA-90PFTN | | IC201 | 9-885-054-84 | IC CS493264-CLR | |
| | | < TRANSISTOR > | | IC205 | 9-885-054-86 | IC CS4228A-KSR | |
| Q2A5 | 9-885-054-74 | TRANSISTOR KTC3882 | | IC206 | 9-885-054-85 | IC CS8415A-CZR | |
| Q2A6 | 9-885-054-74 | TRANSISTOR KTC3882 | | IC301 | 9-885-054-83 | IC PS9702B | |
| | | < VIBRATOR > | | IC501 | 9-885-054-80 | IC NJU7312AM | |
| X201 | 9-885-054-75 | VIBRATOR, CRYSTAL (33.8688MHz) | | IC710 | 9-885-054-79 | IC STA505 | |
| X501 | 9-885-054-76 | VIBRATOR, CRYSTAL (27MHz) | | IC730 | 9-885-054-79 | IC STA505 | |
| ***** | | | | IC750 | 9-885-054-79 | IC STA505 | |
| | 9-885-054-52 | PANEL MOUNT ***** | | IC971 | 9-885-054-81 | IC KA7912TSTU | |
| | | < DIODE > | | | | < JACK > | |
| LD001 | 9-885-054-99 | DIODE LTL-1CHES-112A (STANDBY) | | JK201 | 9-885-054-91 | IC PLR131 (OPTICAL IN) | |
| | | < IC > | | JK202 | 9-885-054-92 | IC PLT131 (OPTICAL OUT) | |
| RMC001 | 9-885-055-00 | IC TPOP4840SJ1 | | JK601 | 9-885-054-93 | PIN JACK 11PIN (ANALOG IN/OUT) | |
| | | < INDICAROE TUBE > | | JK602 | 9-885-054-94 | JAC SCART (EURO AV) | |
| VFD001 | 9-885-054-98 | INDICAROE TUBE, FLUORESCENT | | JK700 | 9-885-054-95 | TERMINAL BLOCK (SPEAKER) | |
| | | < JACK > | | | | < COIL > | |
| JK001 | 9-885-055-01 | JACK, HEADPHONE (PHONES) | | L700 | 9-885-054-88 | COIL, CHOKE | |
| | | < ROTARY ENCODER > | | L711 | 9-885-054-87 | COIL | |
| VR001 | 9-885-055-02 | ENCODER, ROTARY (VOLUME) | | L712 | 9-885-054-87 | COIL | |
| ***** | | | | L721 | 9-885-054-87 | COIL | |
| | | < CONNECTOR > | | L722 | 9-885-054-87 | COIL | |
| | | | | L731 | 9-885-054-87 | COIL | |
| | | | | L732 | 9-885-054-87 | COIL | |
| | | | | L741 | 9-885-054-87 | COIL | |
| | | | | L742 | 9-885-054-87 | COIL | |
| | | | | L761 | 9-885-054-87 | COIL | |
| | | | | L762 | 9-885-054-87 | COIL | |
| | | | | PN104 | 9-885-054-96 | CONNECTOR FFC 12P | |
| | | | | PN901 | 9-885-054-97 | CONNECTOR PIN 10P | |
| | | | | PN902 | 9-885-054-97 | CONNECTOR PIN 10P | |

AVD-LS10

Ver 1.1

MAIN POWER

| Ref. No. | Part No. | Description | Remarks | Ref. No. | Part No. | Description | Remarks |
|-------------------|--------------|---------------------------------|---------|--|--|--|---------|
| < VIBRATOR > | | | | < TRANSISTOR > | | | |
| X101 | 9-885-054-89 | VIBRATOR, CRYSTAL (9.8304MHz) | | △ Q920 | 9-885-055-24 | TRANSISTOR KTA1268 | |
| X201 | 9-885-054-90 | VIBRATOR, CRYSTAL (12.288MHz) | | Q950 | 9-885-055-24 | TRANSISTOR KTA1268 | |
| ***** | | | | | | | |
| 9-885-054-54 | POWER MOUNT | ***** | | < RESISTOR > | | | |
| < CAPACITOR > | | | | △ R900 | 9-885-055-21 | CARBON 1.5M | 1/2W |
| △ C901 | 9-885-055-05 | CERAMIC 2200PF | 400V | △ R921 | 9-885-055-23 | METAL OXIDE 470K | 1W |
| △ C902 | 9-885-055-05 | CERAMIC 2200PF | 400V | R930 | 9-885-055-22 | CEMENT 470 | 10W |
| △ C903 | 9-885-055-05 | CERAMIC 2200PF | 400V | R931 | 9-885-055-22 | CEMENT 470 | 10W |
| △ C904 | 9-885-055-05 | CERAMIC 2200PF | 400V | < TRANSFORMER > | | | |
| △ C905 | 9-885-055-05 | CERAMIC 2200PF | 400V | △ T901 | 9-885-055-25 | TRANSFORMER, POWER | |
| △ C906 | 9-885-055-03 | ELECT 220MF | 450V | △ T902 | 9-885-055-26 | TRANSFORMER, POWER | |
| △ C910 | 9-885-055-04 | FILM 1.2nF | 1kV | < THERMISTOR > | | | |
| △ C911 | 9-885-055-07 | FILM 0.1MF | 100V | △ TH901 | 9-885-055-27 | THERMISTOR, NTPDB5R0LD7B0 | |
| △ C927 | 9-885-055-07 | FILM 0.1MF | 100V | < VARIABLE RESISTOR > | | | |
| C930 | 9-885-055-06 | CERAMIC 470PF | 1kV | △ VR901 | 9-885-055-28 | VARISTOR, SVR10D-471 SW-D-204B | |
| < CONNECTOR > | | | | ***** | | | |
| CN901 | 9-885-055-31 | CONNECTOR, BOARD TO BOARD 10PIN | | MISCELLANEOUS | | | |
| CN902 | 9-885-055-31 | CONNECTOR, BOARD TO BOARD 10PIN | | ***** | | | |
| CN903 | 9-885-055-30 | CONNECTOR PIN 12P | | 11 | 9-885-054-55 | TUNER | |
| < DIODE > | | | | △ 13 | 9-885-054-41 | POWER CORD (AEP) | |
| △ D920 | 9-885-055-08 | DIODE EG01CW | | △ 13 | 9-885-054-42 | POWER CORD (UK) | |
| D931 | 9-885-055-12 | DIODE FFPF10U20STU | | 15 | 9-885-054-59 | CABLE, FLEXIBLE FLAT (23 CORE) (120mm) | |
| D933 | 9-885-055-09 | DIPDE RU4YXLF M20 | | 16 | 9-885-054-56 | CABLE, FLEXIBLE FLAT (12 CORE) | |
| D934 | 9-885-055-11 | DIODE SR340 | | 17 | 9-885-054-58 | CABLE, FLEXIBLE FLAT (24 CORE) | |
| D935 | 9-885-055-11 | DIODE SR340 | | 18 | 9-885-054-57 | CABLE, FLEXIBLE FLAT (23 CORE) (310mm) | |
| D951 | 9-885-055-10 | DIODE SR140 | | △ 56 | 9-885-054-44 | PU BASE ASSY | |
| D952 | 9-885-055-10 | DIODE SR140 | | 57 | 9-885-054-60 | CABLE, FLEXIBLE FLAT (11 CORE) | |
| ***** | | | | | | | |
| < FUSE > | | | | ACCESSORIES | | | |
| △ F901 | 9-885-055-20 | FUSE (5A/250V) | | 9-885-054-61 | REMOTE COMMANDER (RM-LS10) | | |
| < FUSE HOLDER > | | | | 9-885-054-62 | ANTENNA, LOOP (AM) | | |
| FH900A | 9-885-055-18 | HOLDER, FUSE | | 9-885-054-63 | FM-ANTENNA | | |
| FH900B | 9-885-055-18 | HOLDER, FUSE | | 9-885-054-64 | CORD, CONNECTION (for TV CONNECTION) | | |
| < IC > | | | | 4-248-217-11 | MANUAL, INSTRUCTION (ENGLISH) | | |
| △ IC901 | 9-885-055-15 | IC KA5Q1265RF-YDTU | | 4-248-217-21 | MANUAL, INSTRUCTION (FRENCH, SPANISH) (AEP) | | |
| △ IC902 | 9-885-055-14 | IC FSDH0165 | | 4-248-217-31 | MANUAL, INSTRUCTION (GERMAN, DUTCH, ITALIAN) (AEP) | | |
| IC963 | 9-885-055-17 | IC KA378R05 | | 4-248-217-41 | MANUAL, INSTRUCTION (SWEDISH, POLISH) (AEP) | | |
| IC964 | 9-885-055-16 | IC FAN1084T-3.3 | | The components identified by mark △ or dotted line with mark △ are critical for safety. Replace only with part number specified. | | | |
| < COIL > | | | | | | | |
| L931 | 9-885-055-13 | COIL, CHOKE | | | | | |
| L932 | 9-885-055-13 | COIL, CHOKE | | | | | |
| L933 | 9-885-055-13 | COIL, CHOKE | | | | | |
| L951 | 9-885-055-13 | COIL, CHOKE | | | | | |
| < LINE FILTER > | | | | | | | |
| △ LF901 | 9-885-055-19 | FILTER, LINE | | | | | |
| △ LF902 | 9-885-055-19 | FILTER, LINE | | | | | |
| < PIN CONNECTOR > | | | | | | | |
| PN903 | 9-885-055-29 | CONNECTOR PIN 3P | | | | | |

MEMO

