

BM-575/577

SERVICE MANUAL

Ver. 1.1 2006. 10

US Model
AEP Model



Photo: BM-575

SPECIFICATIONS

Tape

MICROCASSETTE™ (normal position type)

Recording system

BM-577: 4-track 2-channel monaural

BM-575: 2-track 1-channel monaural

Speaker

Approx. 2.8 cm (1 1/8 in.) dia.

Tape speed

2.4 cm/s (3/4 ips), 1.2 cm/s (1/2 ips)

Frequency response

BM-577: 250 to 4,000 Hz (at 2.4 cm/s)

BM-575: 300 to 3,500 Hz (at 2.4 cm/s)

Input

Microphone jack (minijack) sensitivity 0.2 mV for low impedance microphone

Output

Earphone jack (minijack) for 8 - 300 ohms earphone

Power output

150 mW (at 10 % harmonic distortion)

Battery life

Continuous recording hours with the built-in microphone:

Approx. 9 hours (average) with alkaline batteries.

Approx. 2 hours with a rechargeable battery after charged for 5 hours.

Power requirements

3V DC

• Two size AAA (R03) batteries (not supplied)

• Sony BP-43 rechargeable battery pack (not supplied)

DC IN 3 V jack accepts:

• Sony AC-E30HG AC power adaptor (not supplied) for use on 120 V

AC, 60 Hz (US model) or 220—230V AC, 50/60Hz (AEP model)

• Sony DCC-E130L car battery cord (not supplied) for use on 12 V car battery.

Dimensions (w/h/d) (incl. projecting parts and controls)

Approx. 60 × 122 × 23.4 mm (w/h/d)

(2 3/8 × 4 7/8 × 1 1/8 in.)

Mass

Approx. 155 g (5.5 oz.)

Approx. 185 g (6.5 oz.) (incl. batteries and cassette)

Supplied accessory

Carrying case (1) (BM-577 only)

Design and specifications are subject to change without notice.

Model Name Using Similar Mechanism	BM-575	BM-540
	BM-577	BM-560
Tape Transport Mechanism Type	BM-575	MB-575-50
	BM-577	MB-577-50

Use only standard Microcassettes with this unit.

Non-standard microcassettes cannot be used because their "L" dimension (see illustration) is different.

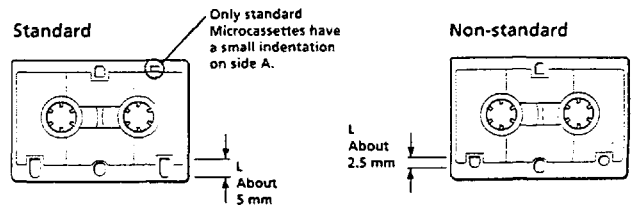

Use the AC-E30HG AC power adaptor (not supplied). Connect the adaptor to the DC IN 3V jack and to a wall outlet. Do not use any other AC power adaptor.

Polarity of the plug



NOTES ON CHIP COMPONENT REPLACEMENT

- Never reuse a disconnected chip component.
- Notice that the minus side of a tantalum capacitor may be damaged by heat.

MICROCASSETTE™ DICTATOR

9-960-235-12

2006J04-1

© 2006. 10

Sony Corporation

Personal Audio Division

Published by Sony Techno Create Corporation

SONY®

SECTION 1 GENERAL

This section is extracted from instruction manual.

TABLE OF CONTENTS

<i>Section</i>	<i>Title</i>	<i>Page</i>
1. GENERAL		
	Welcome !.....	2
	About This Manual	2
	Operation Flow Chart	2
	Dictating with the Built-in Microphone	3
	Listening to the Dictation	3
2. DISASSEMBLY		
2-1.	Lid (Cassette) Assy	4
2-2.	Cabinet (Rear).....	4
2-3.	Cabinet (Front) Assy.....	5
2-4.	Speaker/DC-JACK Board	5
2-5.	Main Board	6
2-6.	Mechanism Deck Block	6
2-7.	Flywheel Assy	7
2-8.	S Reel Table Assy.....	7
2-9.	Take-up Reel Table Assy	8
2-10.	FWD Arm Assy	8
3. MECHANICAL ADJUSTMENTS		9
4. ELECTRICAL ADJUSTMENTS		9
5. DIAGRAMS		
5-1.	Schematic Diagram—Main Section (BM-575)—	11
5-2.	Printed Wiring Boards —Main Section (BM-575)—	13
5-3.	Printed Wiring Boards —Main Section (BM-577)—	17
5-4.	Schematic Diagram—Main Section (BM-577)—	19
6. EXPLODED VIEWS		
6-1.	Cabinet Section	21
6-2.	Chassis Section	22
6-3.	Mechanism Deck Section (1)	23
6-4.	Mechanism Deck Section (2)	25
7. ELECTRICAL PARTS LIST		27

Welcome!

Thank you for purchasing the Sony Microcassette™ Dictator.

Some features are:

- Simple operation with a slide-type function lever.
- You can put electronic indexing marks on recording (BM-577 only).
- Three BATT lamps (including the DICT/BATT lamp) indicate the battery condition step by step (BM-577 only).
- VOR (Voice Operated Recording) system that starts and stops recording automatically in response to the sound, to save tapes and batteries.
- Three-digit tape counter for indexing the tape contents.
- FAST PB (fast playback) function that lets you listen to the tape with high speed.
- LOCK switch prevents the unit from accidental operation.
- 3-way powering system: batteries, AC house current and car battery.
- Tape-end alarm sounds at the end of the tape.

About This Manual

The instructions in this manual are for 2 models. The BM-577 is the model used for illustration purposes. Any differences in operation are clearly indicated in the text, for example, "BM-577 only."

Operation Flow Chart

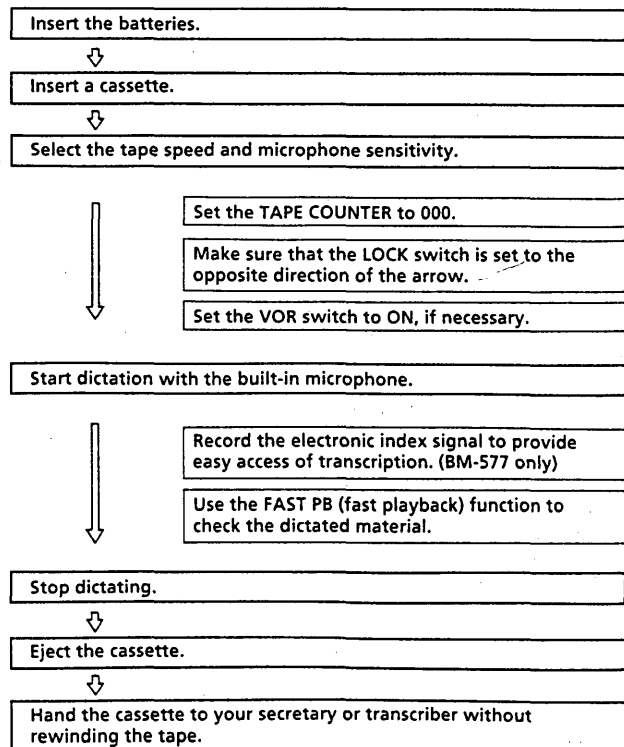

▶ Operating the Unit

Dictating with the Built-in Microphone

You can start and stop dictating simply by sliding the function lever.

- Before operating, make sure the following points.
- The LOCK switch is set to the opposite direction of the arrow.
- Nothing is connected to the MIC (microphone) jack.
- Set the VOR (Voice Operated Recording) switch to ON, if necessary.

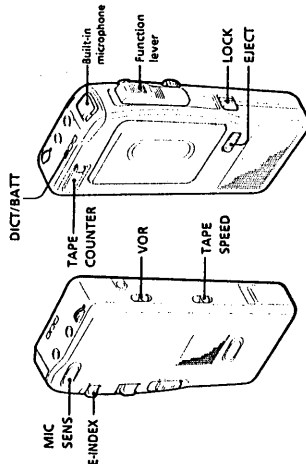

- 1 Slide the EJECT lever to open the cassette compartment lid.
- 2 Insert a cassette with the side to start dictating facing the lid.
- 3 Set the TAPE SPEED selector to the desired tape speed.

Recording time*	Set to
60 minutes	2.4 cm**
120 minutes	1.2 cm

- * Using both sides of the MC-60/90/180 Microcassette.
 - ** For optimum sound (recommended for normal use), set to 2.4 cm.
- 4 Set the MIC SENS (microphone sensitivity) selector to the desired position.

Use for	Set to
Normal use	DICT (dictation)
Recording a conference or telephone conversation	CONF (conference)

- 5 Slide up the function lever to DICT (dictation).
- 6 Speak into the microphone. The DICT/BATT lamp flashes depending on the strength of the sound during recording.
- 7 To stop dictating, slide down the function lever to STOP. To eject a cassette, slide the EJECT lever.

To economize the tapes and batteries

Set the VOR switch to ON. The tape moves only when sound is picked up, and stops automatically when sound is no longer detected (The DICT/BATT indicator goes out.), thus the minimum amount of tape is used.

To index the tape contents

Set the TAPE COUNTER to 000 by pushing the reset button before dictating.

To monitor the recording

Connect an earphone to the EAR (earphone) jack.

To listen to the just-recorded contents while dictating

Slide down the function lever to B SPACE (back space), and release it at the desired point.

When a beep sounds and the DICT/BATT lamp goes out

The tape reaches the end. Slide the function lever to STOP.

To erase the entire tape contents

Use the BE-9H cassette eraser (not supplied).

Putting Marks during Recording for Easy Access (BM-577 only)

Press E-INDEX lightly when you have special instructions for your secretary about the material or mark the end of the letter. An electronic index signal will be recorded on the tape.

This signal is the same as the LTR signal of the Sony transcriber. When your secretary uses the Sony transcriber equipped with auto-stop function, the tape automatically stops at each index signal when it is rewound or rapidly advanced. Your secretary will be able to search a necessary dictation easily.

Note

The cue-maker function of some Sony microcassette-order may not operate on the electronic indexing mark recorded with the BM-577, because the cue-maker function and the electronic indexing function have no effect each other.

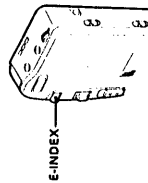

Dictating with an External Microphone or with Telephone Recording Adaptor

Connect the microphone to the MIC jack. When connecting the electret condenser microphone with "plug-in power" system, the power of the microphone is supplied from this unit.

For telephone recording, connect the TL-4 telephone recording adaptor (not supplied) to the MIC jack. For details, refer to the TL-4 instruction manual.

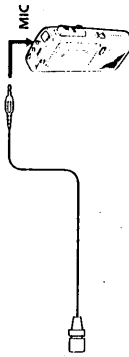

Listening to the Dictation

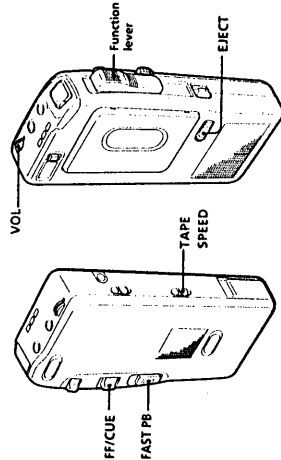

Make sure that the LOCK switch is set to the opposite direction of the arrow.

- 1 Slide the EJECT lever to open the cassette compartment lid.
- 2 Insert a cassette with the side to start listening facing the lid.
- 3 Set the TAPE SPEED selector to the same position as that in recording.
- 4 Slide down the function lever to LISTEN.
- 5 Adjust VOL (volume).
- 6 To stop playback, slide up the function lever to STOP.

To listen to the tape at a faster speed than normal

Slide up the FAST PB (fast playback) switch while listening to the tape.

To rewind the tape

Slide down the function lever at the B SPACE (back space) and release it at the desired point.

To rapidly advance the tape

Slide the FF/CUE lever in the direction of the arrow, with the function lever set to STOP. To stop the tape, release the FF/CUE lever.

To skip over unnecessary portions

During playback, slide the FF/CUE lever in the direction of the arrow. When you release the lever, the unit will automatically return to the playback mode.

For private listening

Connect the earphone to the EAR jack and the sound does not come out through the speaker.

SECTION 2 DISASSEMBLY

Note: Follow the disassembly procedure in the numerical order given.

2-1. LID (CASSETTE) ASSY

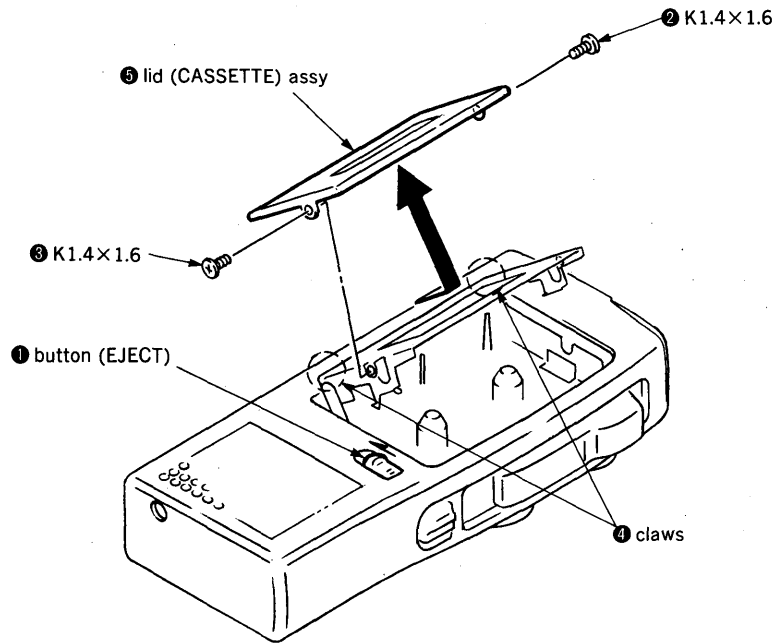

2-2. CABINET (REAR)

Note: On install, set to the knobs and switches.

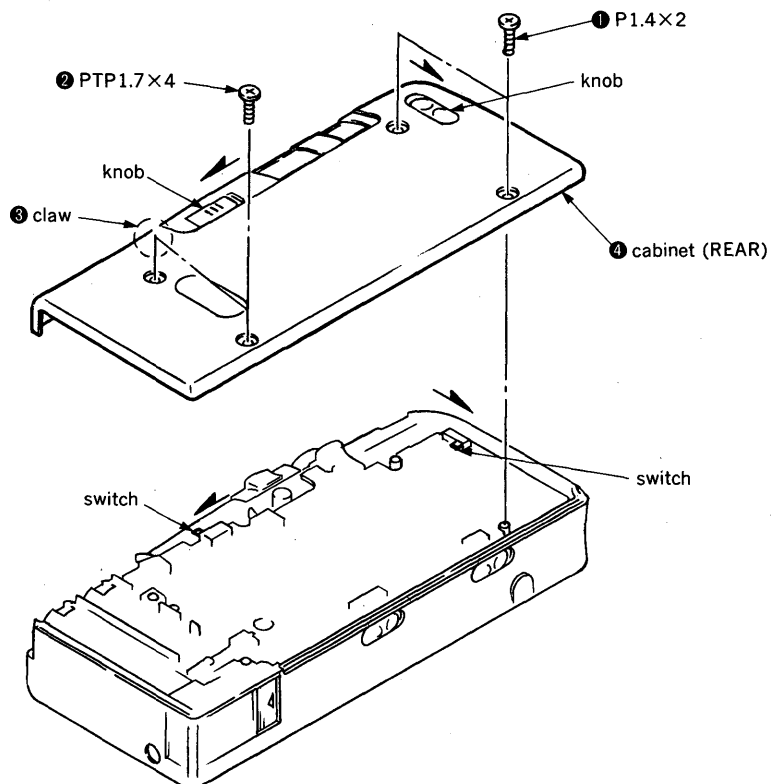

2-3. CABINET (FRONT) ASSY

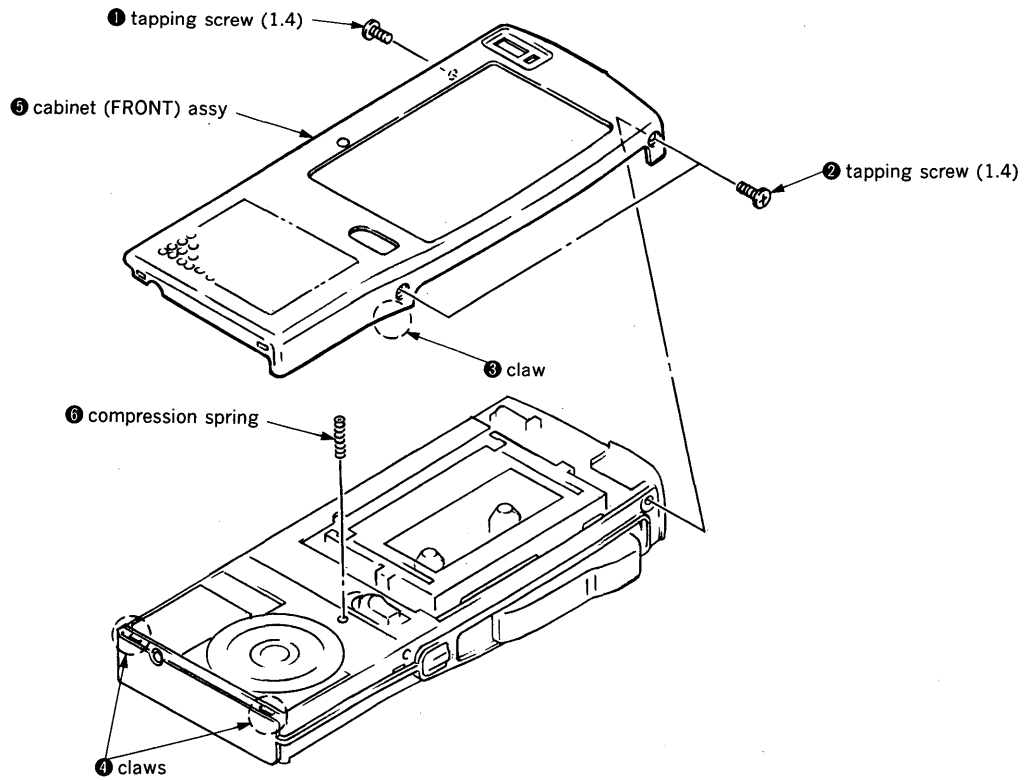

2-4. SPEAKER/DC-JACK BOARD

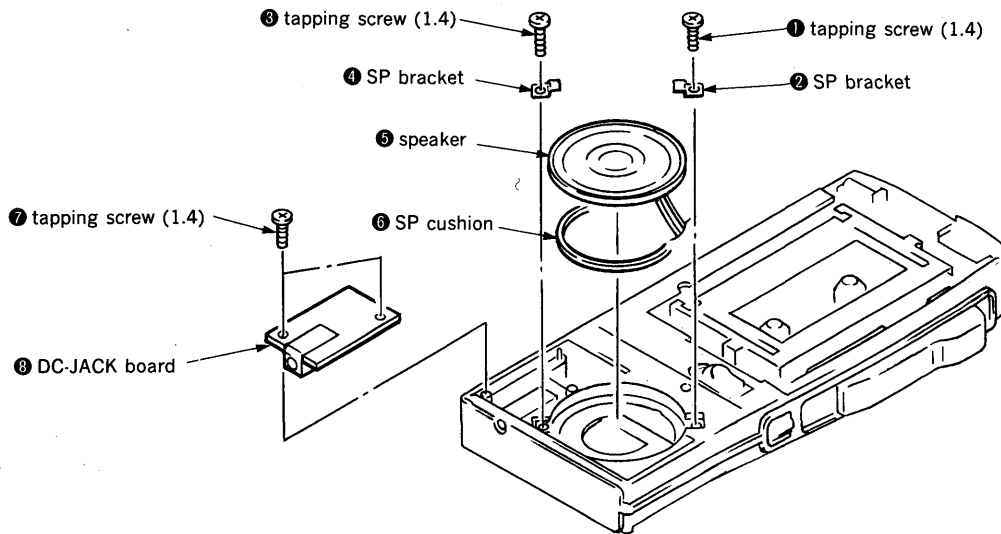

2-5. MAIN BOARD

Note: On install, set to the knobs and switches.
Control button assy to the set on STOP position.

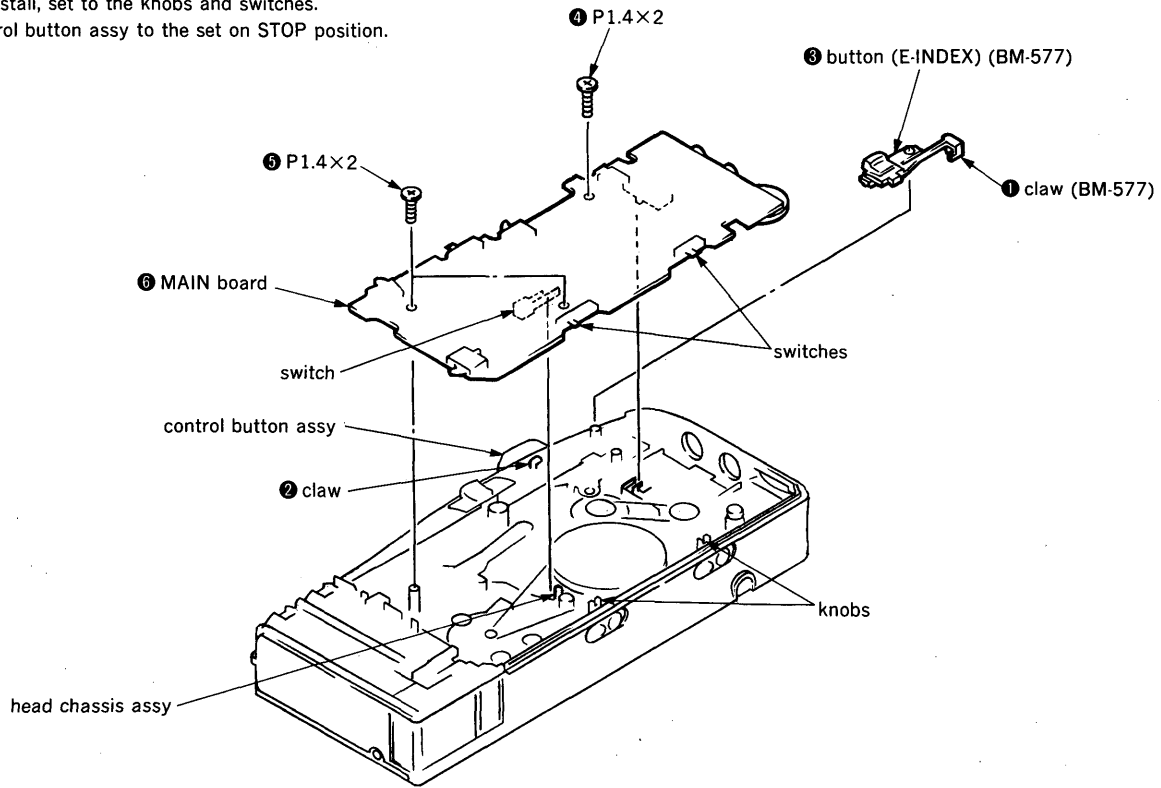

2-6. MECHANISM DECK BLOCK

Note: On install, set to the knobs and lever of mechanism deck block.

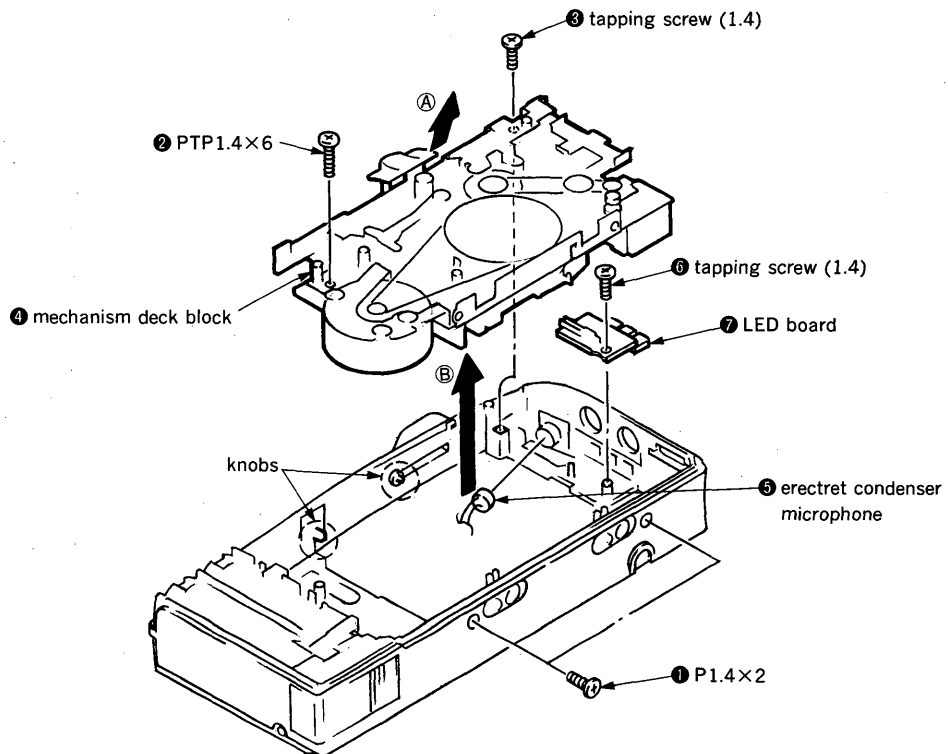

2-7. FLYWHEEL ASSY

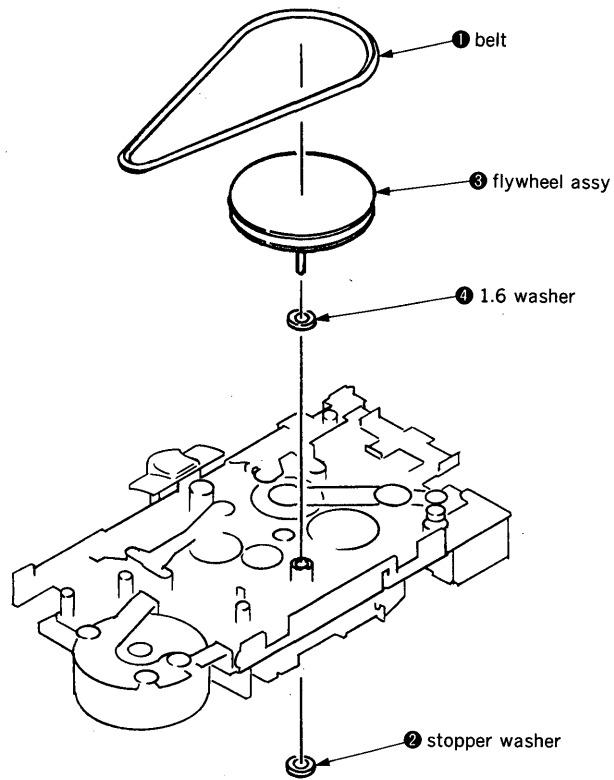

2-8. S REEL TABLE ASSY

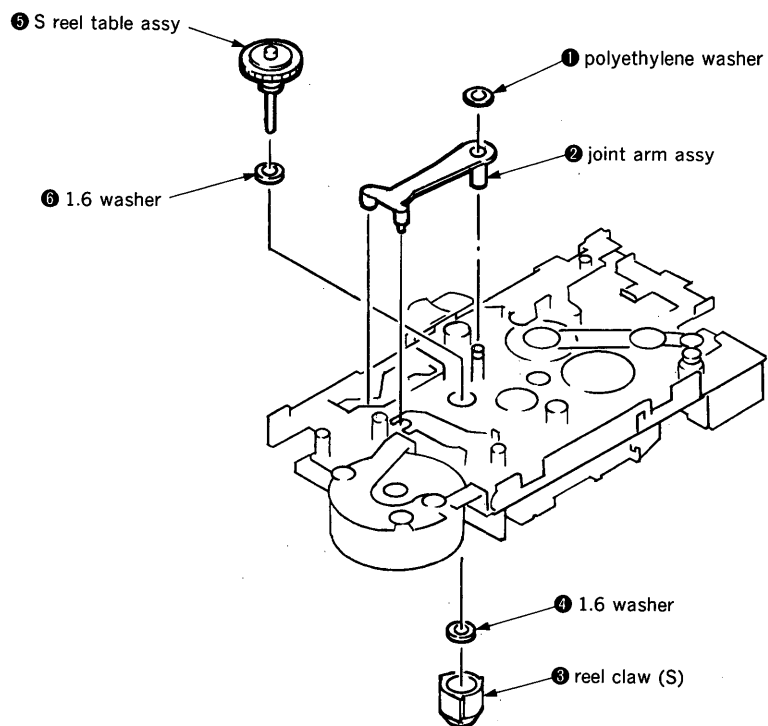

2-9. TAKE-UP REEL TABLE ASSY

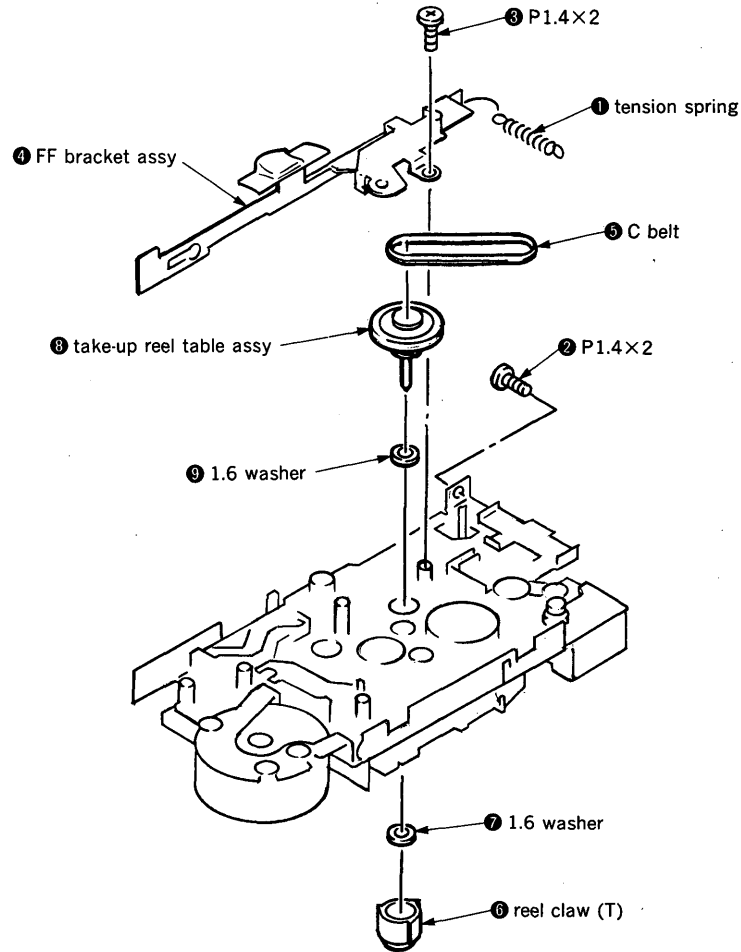

2-10. FWD ARM ASSY

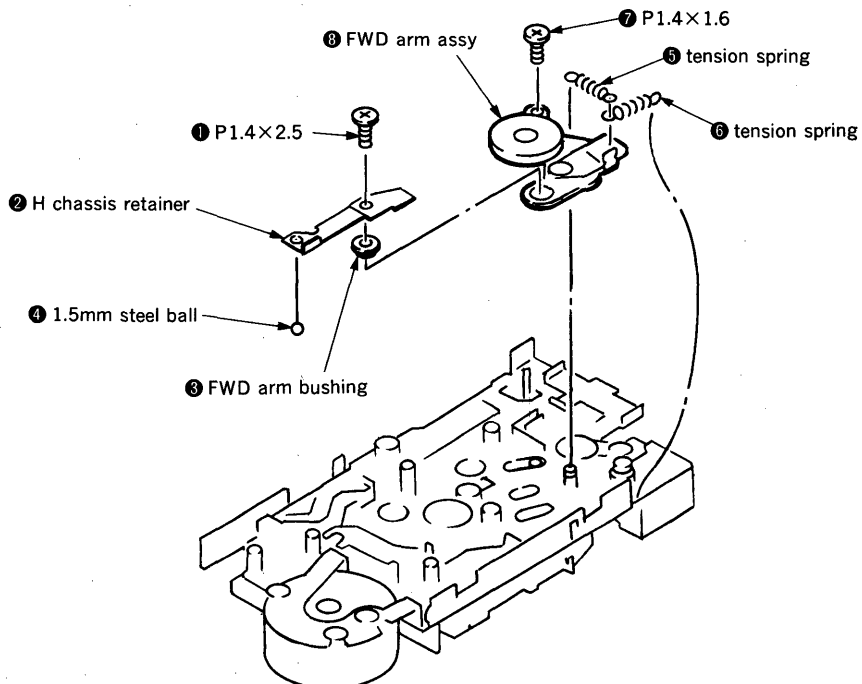

SECTION 3 MECHANICAL ADJUSTMENTS

PRECAUTION

1. Clean the following parts with a denatured alcohol moistened swab :
 record/playback head (BM-577) erase head (BM-577)
 record/playback/erase head (BM-575) pinch roller
 rubber belts capstan idlers
 2. Demagnetize the record/playback/(erase) head with a head demagnetizer.
 3. Do not use a magnetized screwdriver for the adjustments.
 4. After the adjustments, apply suitable locking compound to the parts adjusted.
 5. The adjustments should be performed with the rated power supply voltage (dc 2.5V) unless otherwise noted.
- Switches and control should be set as follows unless otherwise specified.

MIC SENS selector	: CONF
TAPE SPEED selector	: 2.4cm
FAST PB switch	: OFF
VOR switch	: OFF
VOL control	: mechanical center

Torque Measurement

Mode	Torque meter (Cassette type)	Meter reading
LISTEN	CQ-103M	5-12g·cm (0.069-0.167 oz·inch)
FF/CUE	CQ-201M	more than 5g·cm (more than 0.069 oz·inch)
B. SPACE	CQ-201M	more than 14g·cm (more than 0.194 oz·inch)

Tape Tension Measurement

Mode	Tension meter (Cassette type)	Meter reading
LISTEN	CQ-403M	25-55g (0.88-1.94 oz)

Timing Adjustment

1. Take-up reel spindle should rotate at the same time as pinch roller or earlier than pinch roller in STOP to LISTEN/DICT mode.
 Confirm that the pinch roller presses to capstan and they rotate.
2. When they are not correctly rotate, adjust the place of adjustment plate so that it is wide.

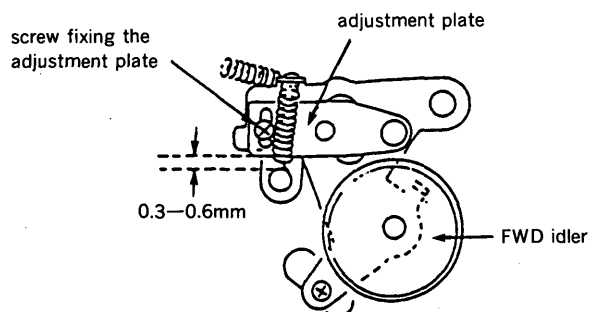

SECTION 4 ELECTRICAL ADJUSTMENTS

PRECAUTION

1. Demagnetize the record/playback/(erase) head with a head demagnetizer.
 2. Do not use a magnetized screwdriver for the adjustments.
 3. After the adjustments, apply suitable locking compound to the parts adjusted.
 4. The adjustments should be performed with the rated power supply voltage (dc 2.5V) unless otherwise noted.
 5. The adjustments should be performed in the order given in this service manual. (As a general rule, playback circuit adjustment should be completed before performing recording circuit adjustment.)
- Switches and control should be set as follows unless otherwise specified.

MIC SENS selector	: CONF
TAPE SPEED selector	: 2.4cm
FAST PB switch	: OFF
VOR switch	: OFF
VOL control	: mechanical center

Test Tape

Type	Signal	Used for
WS-24	3kHz, -10dB	Tape Speed (2.4cm) Adjustment
WS-12	3kHz, -10dB	Tape Speed (1.2cm) Adjustment
S-2-A030	3kHz, -20dB	Head Azimuth Adjustment

Tape Speed (2.4cm) Adjustment

Setting :

TAPE SPEED selector : 2.4cm

Procedure :

1. Mode : LISTEN

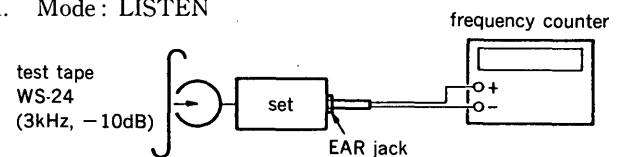

2. Adjust RV102 so that the frequency counter reads 2,990 to 3,010Hz.

Adjustment Location : See page 10.

Tape Speed (1.2cm) Adjustment

Setting :

TAPE SPEED selector : 1.2cm

Procedure :

1. Mode : LISTEN

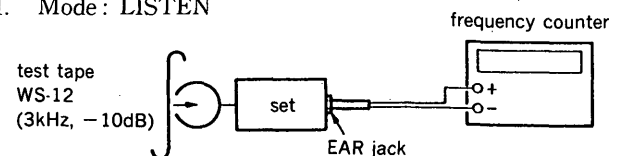

2. Adjust RV103 so that the frequency counter reads 2,990 to 3,010Hz.

Adjustment Location : See page 10.

Adjustment Location :

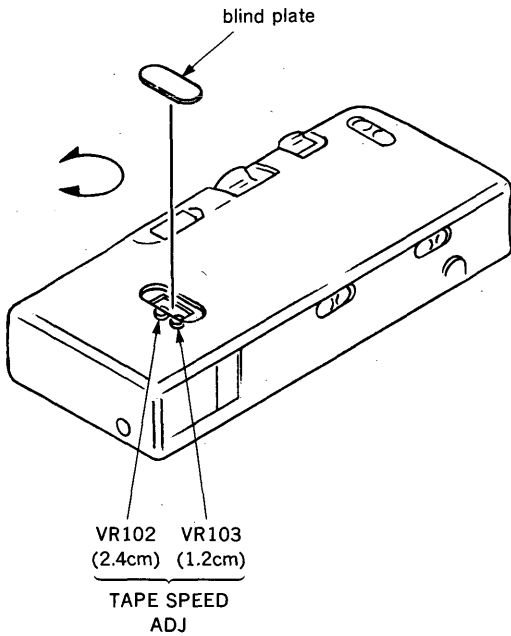

Record/playback Head Azimuth Adjustment

Procedure :

1. Mode : LISTEN

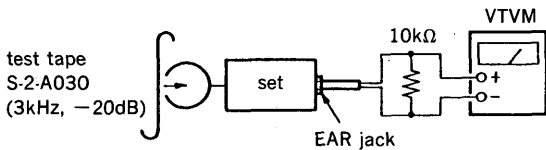

2. Turn the adjustment screw for maximum VTVM reading.

Note : Several peaks may appear, but take the maximum.

Adjustment Location :

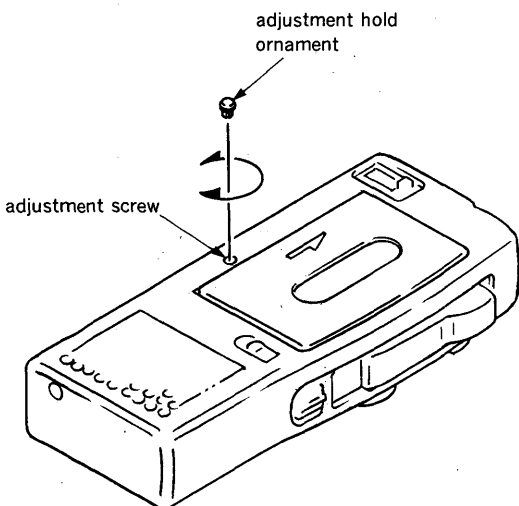

Record Bias Adjustment

Setting :

TAPE SPEED selector : 2.4cm

Procedure :

1. Mode : DICT (record)

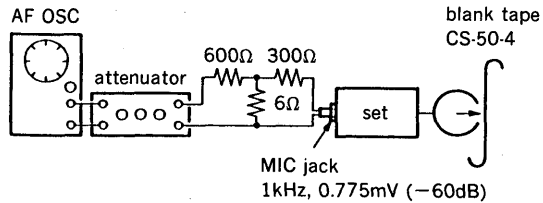

2. Mode : LISTEN (playback)

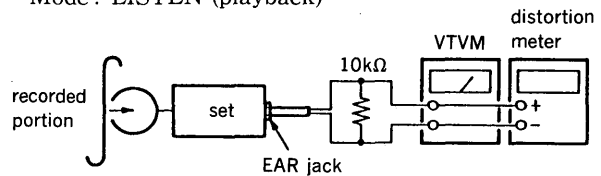

3. LISTEN (playback) the signal recorded in step 1.
4. Turn the VOL control so that the VTVM reads within 0dB.

Confirm that the distortion meter reads within adjustment limits.

5. Set the TAPE SPEED selector to 1.2cm and repeat steps 1 to 4.
6. If the adjustment limits are not satisfied, soldering the tap as follows.

Adjustment limits :

tape speed	distortion
2.4cm/s	within 10%
1.2cm/s	within 14%

Soldering Point : main board (conductor side)

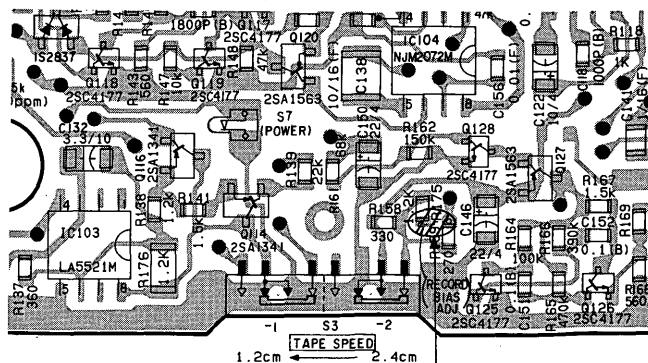

If the adjustment limits are not satisfied, soldering the tap.

SECTION 5
DIAGRAMS

5-1. SCHEMATIC DIAGRAM—MAIN SECTION (BM-575)—

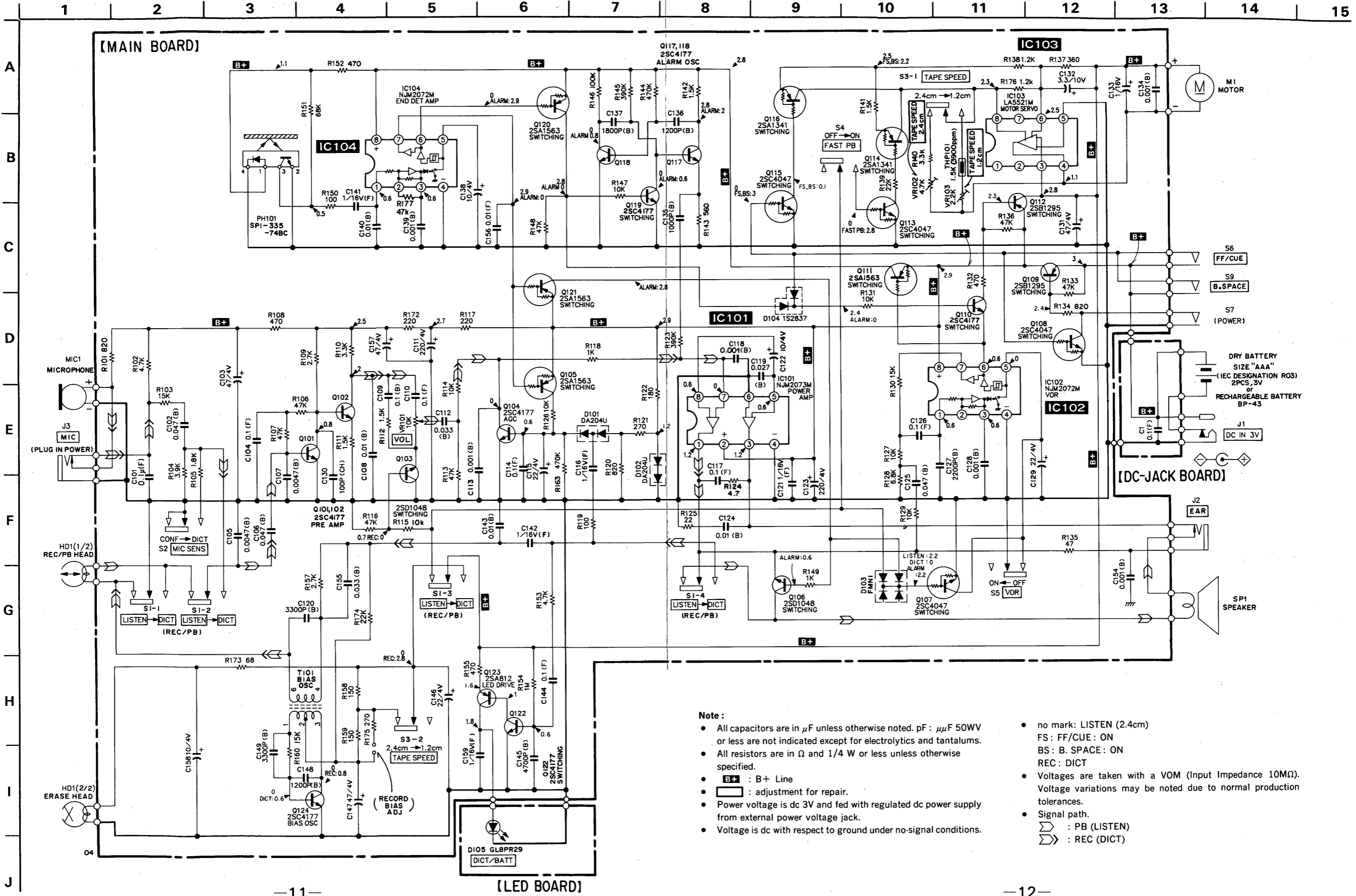

Note:

- All capacitors are in μF unless otherwise noted. pF : μF 50WV or less are not indicated except for electrolytics and tantalums.
- All resistors are in Ω and 1/4 W or less unless otherwise specified.
- **B+** : B+ Line
- : adjustment for repair.
- Power voltage is dc 3V and fed with regulated dc power supply from external power voltage jack.
- Voltage is dc with respect to ground under no-signal conditions.

- no mark: LISTEN (2.4cm)
- FS: FF/CUE: ON
- BS: B. SPACE: ON
- REC: DICT
- Voltages are taken with a VOM (Input Impedance 10M Ω). Voltage variations may be noted due to normal production tolerances.
- Signal path.
- : PB (LISTEN)
- : REC (DICT)

5-2. PRINTED WIRING BOARDS—MAIN SECTION (BM-575)—

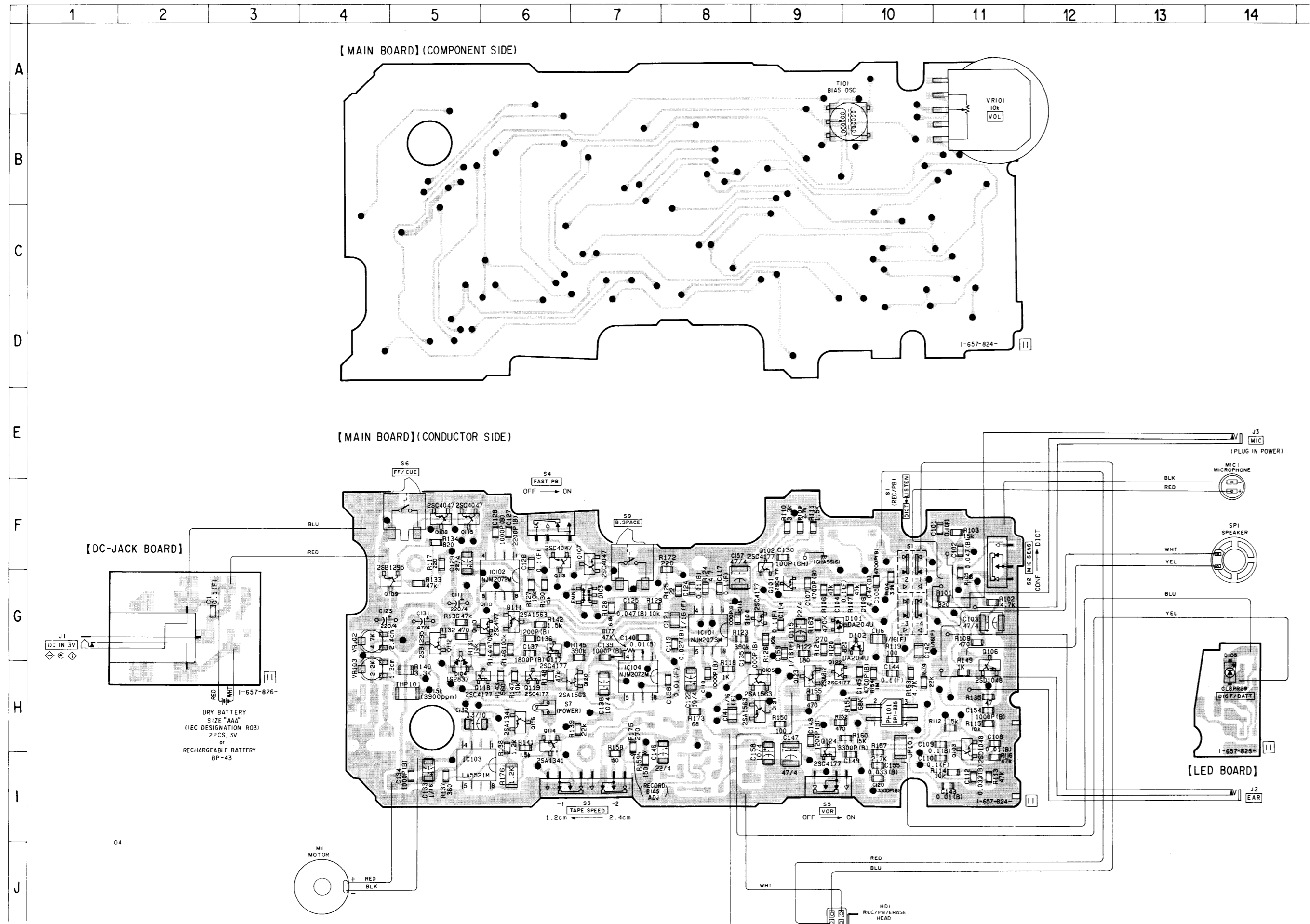

• Semiconductor Location

Ref. No.	Location
D101	G-10
D102	G-10
D103	G-7
D104	H-5
D105	H-14
IC101	G-8
IC102	G-6
IC103	I-5
IC104	H-7
Q101	G-9
Q102	F-9
Q103	H-11
Q104	G-9
Q105	H-9
Q106	H-11
Q107	F-7
Q108	F-5
Q109	G-5
Q110	G-6
Q111	G-6
Q112	G-5
Q113	F-6
Q114	H-6
Q115	F-5
Q116	H-6
Q117	G-6
Q118	H-6
Q119	H-6
Q120	H-7
Q121	H-9
Q122	H-9
Q123	H-9
Q124	H-9

Note:
 • : parts extracted from the conductor side.
 • : Through hole.
 • : Pattern on the side which is seen.
 (The other layer's patterns are not indicated.)

5-3. PRINTED WIRING BOARDS—MAIN SECTION (BM-577)—

• Semiconductor Location

Ref. No.	Location
D1	G-3
D101	G-10
D102	G-10
D103	G-7
D104	G-5
D105	H-14
D106	H-14
D107	G-14
IC101	G-8
IC102	G-6
IC103	I-5
IC104	H-7
Q101	G-9
Q102	F-9
Q103	H-11
Q104	G-9
Q105	H-9
Q106	H-11
Q107	F-7
Q108	F-5
Q109	G-5
Q110	G-6
Q111	G-6
Q112	G-5
Q113	F-6
Q114	H-6
Q115	F-5
Q116	H-6
Q117	G-6
Q118	H-6
Q119	H-6
Q120	H-7
Q121	H-9
Q122	H-9
Q123	H-9
Q124	H-9
Q125	I-7
Q126	I-8
Q127	H-8
Q128	H-7

Note:
 - : parts extracted from the conductor side.
 • : Through hole.
 - : Pattern on the side which is seen.
 (The other layer's patterns are not indicated.)

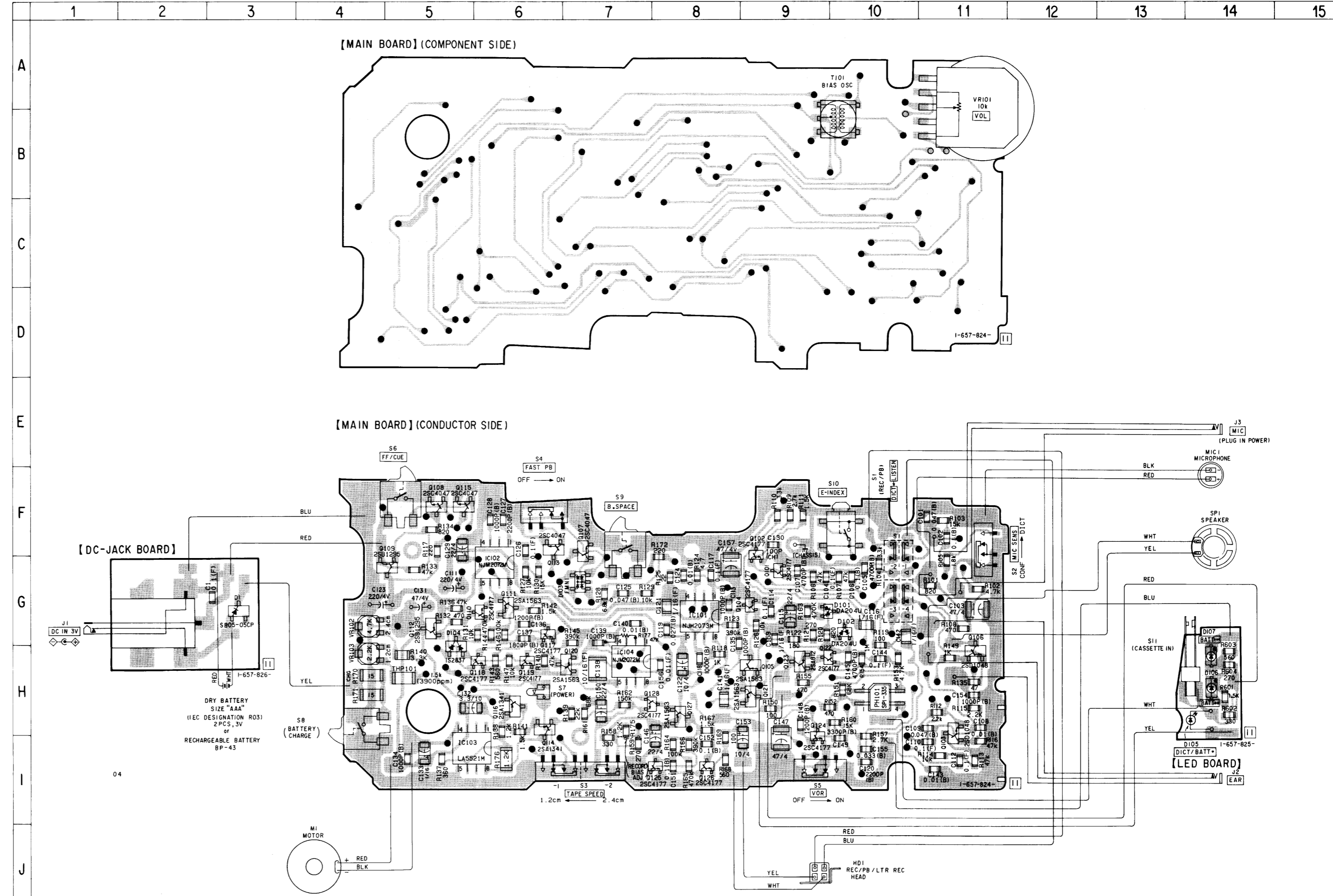

5-4. SCHEMATIC DIAGRAM—MAIN SECTION (BM-577)—

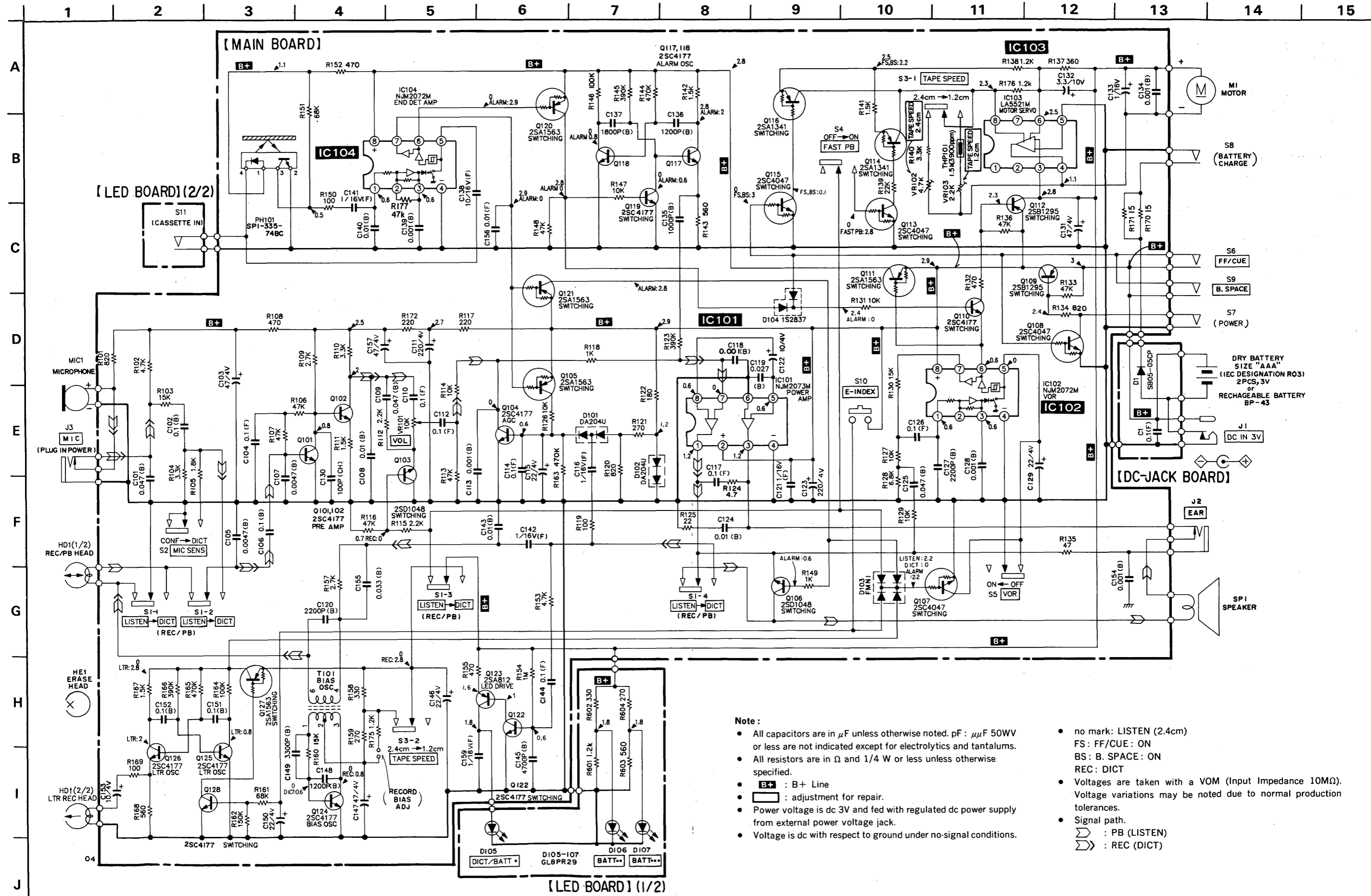

SECTION 6 EXPLODED VIEWS

NOTE:

- The mechanical parts with no reference number in the exploded views are not supplied.
- Items marked "*" are not stocked since they are seldom required for routine service. Some delay should be anticipated when ordering these items.

- -XX and -X mean standardized parts, so they may have some difference from the original one.
- Color Indication of Appearance Parts
Example :
KNOB, BALANCE (WHITE)... (RED)
 ↑ ↑
 Parts Color Cabinet's Color

- Hardware (# mark) list and accessories and packing materials are given in the last of this parts list.

6-1. CABINET SECTION

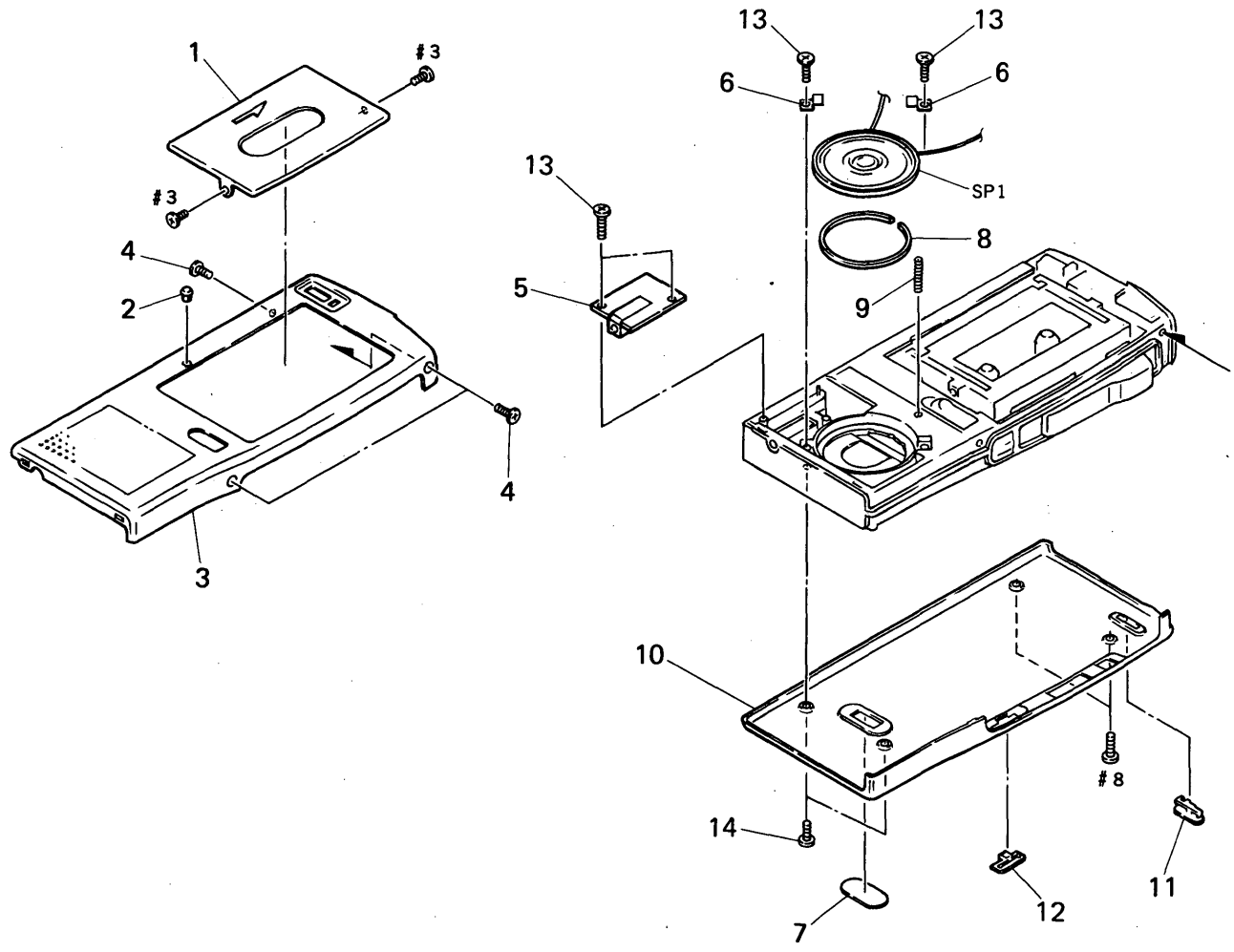

Ref. No.	Part No.	Description	Remark
1	A-3042-794-A	LID (CASSETTE) ASSY	
2	3-578-232-21	ORNAMENT, ADJUSTMENT HOLE	
3	A-3042-786-A	CABINET (FRONT) ASSY (BM-575)	
3	A-3042-789-A	CABINET (FRONT) ASSY (BM-577)	
4	3-672-586-01	SCREW (1.4), TAPPING	
*	1-657-826-11	DC-JACK BOARD	
*	3-927-397-01	BRACKET, SP	
7	3-927-400-01	PLATE, BLIND	
8	3-927-396-01	CUSHION, SP	

Ref. No.	Part No.	Description	Remark
9	3-927-395-01	SPRING, COMPRESSION	
10	3-926-697-01	CABINET (REAR) (BM-577)	
10	3-926-697-11	CABINET (REAR) (BM-575)	
11	3-927-405-01	KNOB (MIC SENS)	
12	3-927-406-01	KNOB (FAST PB)	
13	3-309-597-01	SCREW (1.4), TAPPING	
14	3-947-677-01	SCREW (1.7X4), TAPPING (B)	
SP1	1-504-961-11	SPEAKER	

6-2. CHASSIS SECTION

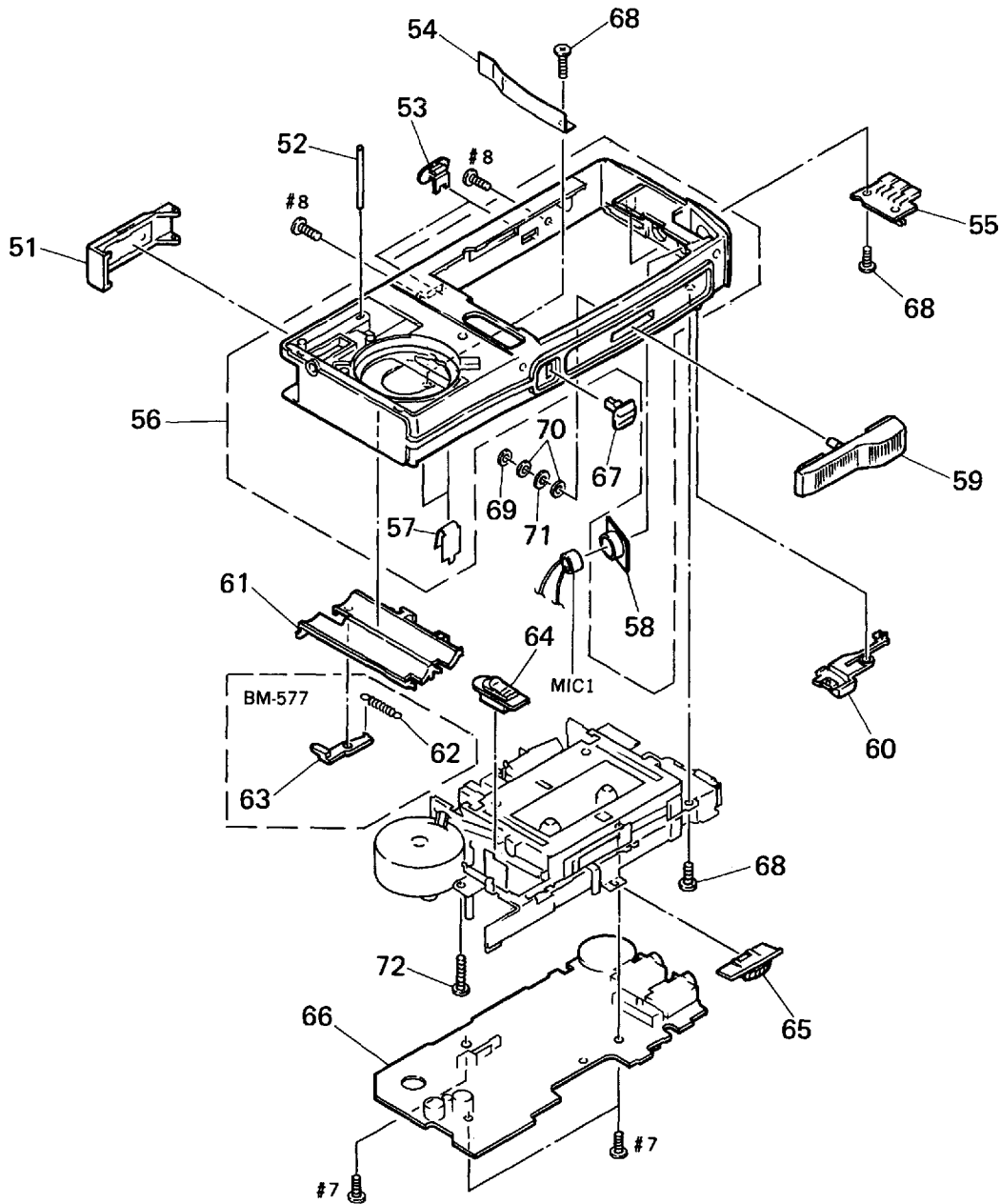

Ref. No.	Part No.	Description	Remark	Ref. No.	Part No.	Description	Remark
51	A-3042-793-A	LID ASSY, BATTERY CASE		63	3-927-401-01	LEVER, CHARGE SWITCH (BM-577)	
52	3-927-394-01	SHAFT (BATTERY CASE LID)		64	3-927-399-01	BUTTON (EJECT)	
53	3-927-398-01	KNOB (TAPE SPEED)		65	3-927-403-01	KNOB (FF/CUE)	
* 54	3-927-393-01	SPRING, BATTER CASE LID		* 66	A-3016-730-A	MAIN BOARD, COMPLETE (BM-575)	
* 55	1-657-825-11	LED BOARD		* 66	A-3016-735-A	MAIN BOARD, COMPLETE (BM-577)	
56	A-3042-788-A	CABINET (MIDDLE) ASSY (BM-575)		67	3-927-392-01	BUTTON (LOCK)	
56	A-3042-791-A	CABINET (MIDDLE) ASSY (BM-577)		68	3-309-597-01	SCREW (1.4), TAPPING	
57	3-927-413-01	SPRING, BATTERY		69	3-321-813-01	WASHER, COTTER POLYETHYLENE	
58	3-306-145-01	HOLDER (MICPHONE)		70	3-701-437-01	WASHER	
59	A-3042-792-A	BUTTON ASSY, CONTROL		* 71	3-557-857-01	CUSHION, VIBRATION PREVENTION	
60	3-927-404-01	BUTTON (E-INDEX)		72	3-309-597-61	SCREW (1.4X6), TAPPING	
* 61	3-927-499-01	COVER, BATTERY		MIC1	1-542-197-11	MICROPHONE, ELECTRET CONDENSER	
62	3-927-402-01	SPRING, TENSION (BM-577)					

6-3. MECHANISM DECK SECTION (1)
 (MB-575-50: BM-575)
 (MB-577-50: BM-577)

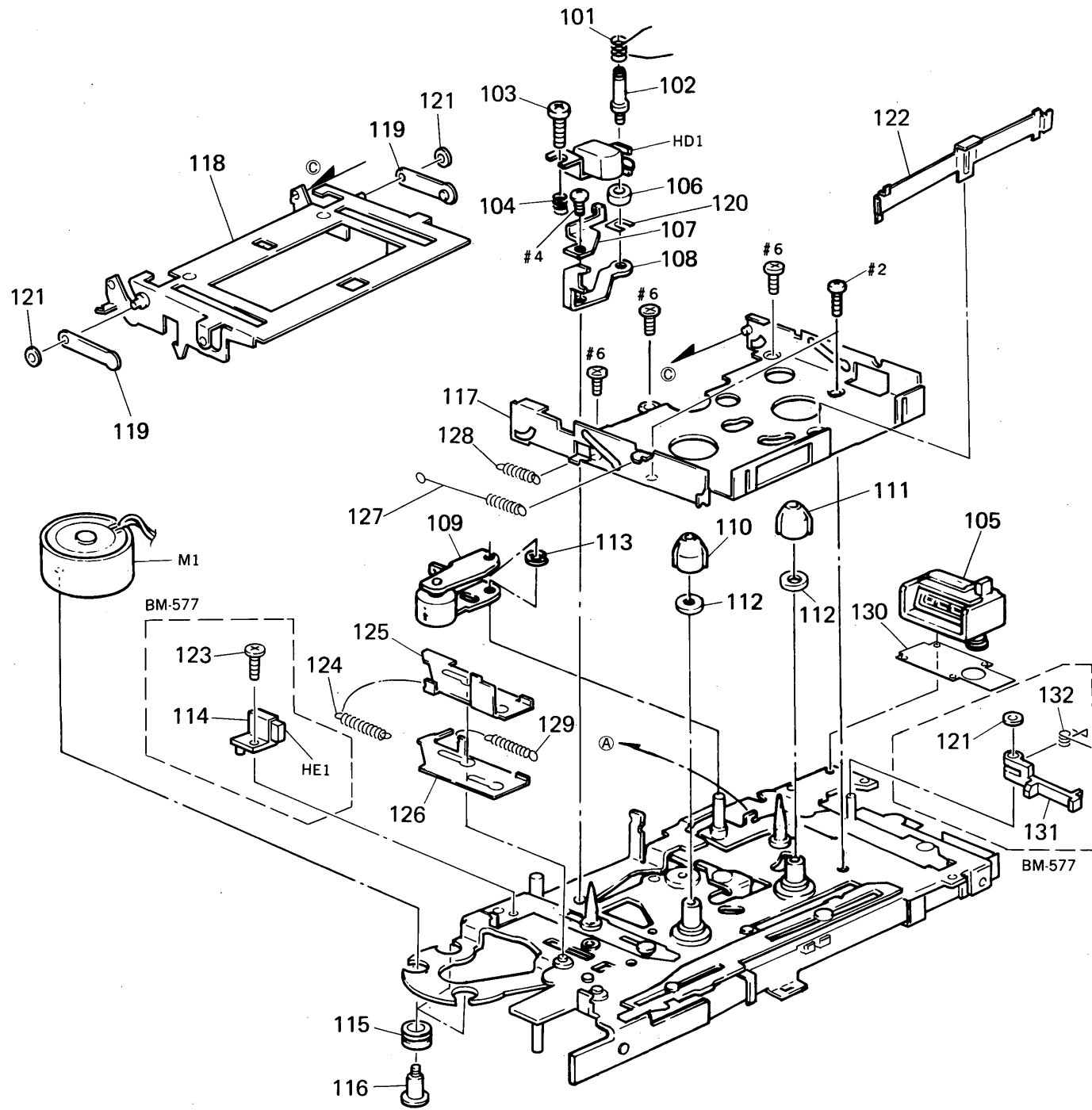

Ref. No.	Part No.	Description	Remark
101	3-306-149-01	SPRING, TORSION	
102	3-306-165-01	SHAFT (HEAD FITTING)	
103	3-704-375-01	SCREW (1.7X5.5), (+P), PRECISION	
104	3-570-558-00	SPRING, COMPRESSION	
105	1-548-516-00	TIMER, TAPE	
106	3-306-164-01	SPACER (HEAD)	
* 107	3-302-476-00	CLAMP	
* 108	3-302-464-00	GUIDE, TAPE	
109	X-3302-409-0	PINCH LEVER ASSY	
110	3-302-459-00	CLAW (S), REEL	
111	3-302-460-00	CLAW (T), REEL	
112	3-701-436-01	WASHER, 1.6	
113	3-578-255-11	RING (E1.5), RETAINING	
* 114	3-302-474-00	BRACKET, ERASE HEAD (BM-577)	
115	3-309-836-01	SHAFT, FITTING, MOTOR	
116	3-570-770-00	CUSHION (A), MOTOR	
117	X-3370-774-1	PANEL ASSY, SUB	
118	X-3370-775-1	HOLDER ASSY, LID	
* 119	X-3370-773-1	ARM ASSY	

Ref. No.	Part No.	Description	Remark
120	3-578-138-01	SHIM (t=0.1)	
120	3-578-138-11	SHIM (t=0.2)	
121	3-315-384-11	WASHER, STOPPER	
* 122	3-927-428-01	RETAINER (A), CASSETTE	
123	3-704-374-01	SCREW (1.4X2.5), (+P), PRECISION (BM-577)	
124	3-927-425-01	SPRING, TENSION	
* 125	3-924-116-01	LEVER, EJECT	
* 126	3-924-115-01	LEVER, LOCK	
127	3-927-427-01	SPRING, TENSION	
128	3-927-426-01	SPRING, TENSION	
129	3-927-424-01	SPRING, TENSION	
130	3-928-722-01	PLATE, COUNTER	
* 131	3-927-441-01	LEVER, CASSETTE DETECTION (BM-577)	
132	3-927-442-01	SPRING, CASSETTE DETECTION (BM-577)	
HD1	1-500-271-11	HEAD, MAGNETIC (REC/PB/ERASE) (BM-575)	
HD1	1-543-725-11	HEAD, MAGNETIC (REC/PB) (BM-577)	
HE1	8-825-772-01	ESF194-62G (ERASE HEAD) (BM-577)	
M1	A-3042-785-A	MOTOR ASSY	

6-4. MECHANISM DECK SECTION (2)
 (MB-575-50: BM-575)
 (MB-577-50: BM-577)

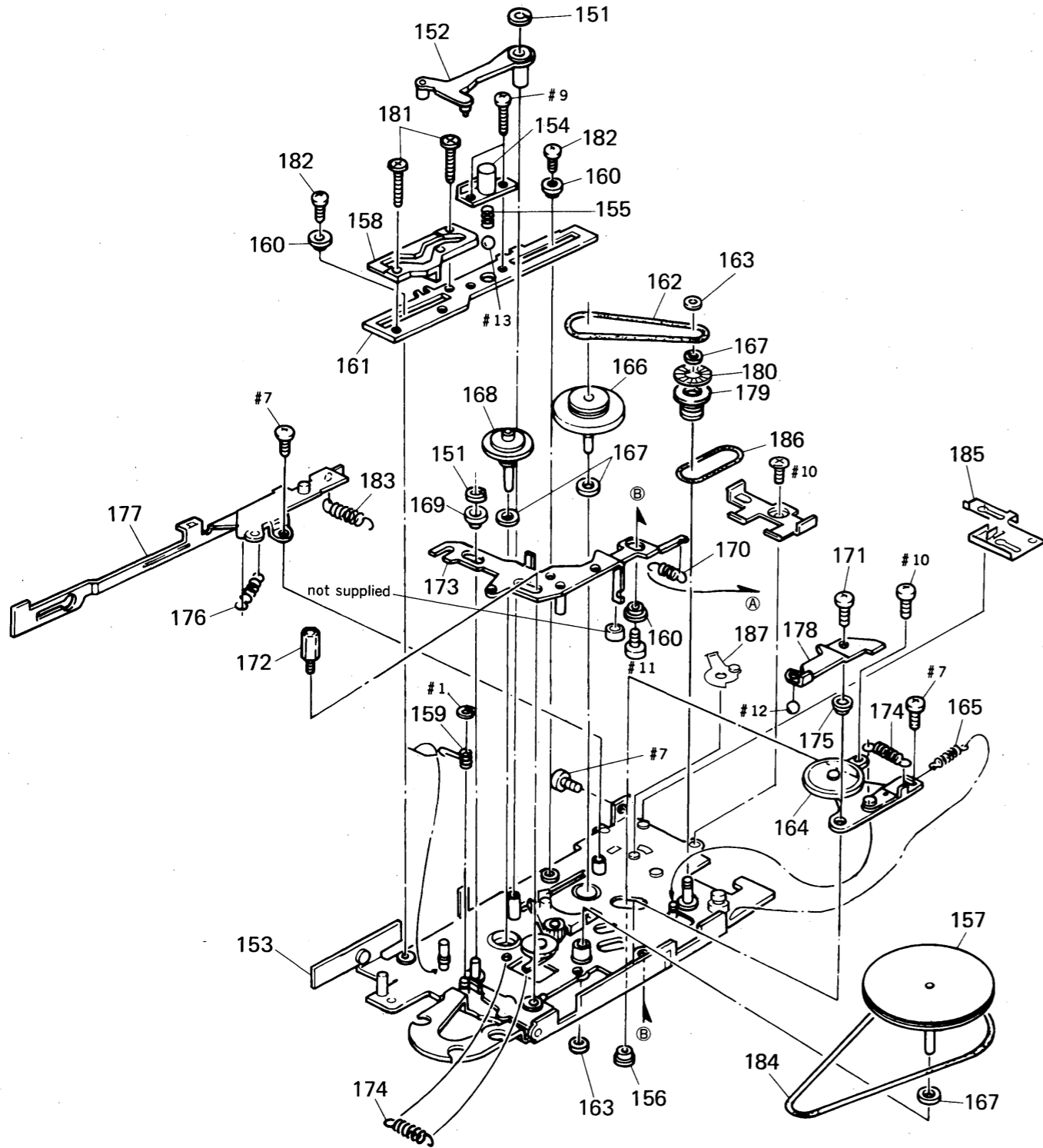

Ref. No.	Part No.	Description	Remark	Ref. No.	Part No.	Description	Remark
151	3-311-815-11	WASHER, POLYETHYLENE		170	3-570-552-00	SPRING, TENSION	
152	X-3306-122-1	ARM ASSY, JOINT		171	3-704-374-01	SCREW (1.4X2.5), (+P), PRECISION	
153	X-3370-769-1	CHASSIS ASSY, MECHANICAL		* 172	3-306-186-01	SHAFT (PC BOARD GUIDE)	
* 154	3-302-461-00	RETAINER, SPRING		* 173	X-3306-123-1	CHASSIS ASSY, HEAD (BM-577)	
155	3-302-567-01	SPRING (STEEL BALL), COMPRESSION		* 173	X-3370-771-1	CHASSIS ASSY, HEAD (BM-575)	
156	3-302-495-00	GUIDE, ARM, FWD		174	3-561-634-00	SPRING, TENSION	
157	X-3306-111-1	FLYWHEEL ASSY		* 175	3-302-541-00	BUSHING, FWD ARM	
* 158	3-306-197-01	GUIDE (B), CONTROL		176	3-527-188-00	SPRING, TENSION	
159	3-302-490-00	SPRING, BS. RETURN		* 177	X-3370-770-1	BRACKET ASSY, FF	
160	3-302-536-00	GUIDE, CONTROL LEVER		* 178	3-302-462-00	RETAINER, H CHASSIS	
* 161	3-924-114-01	LEVER, CONTROL		179	3-927-429-01	PULLEY, RELAY	
162	3-561-645-00	BELT, C		180	3-927-430-01	REFLECTOR	
163	3-315-384-11	WASHER, STOPPER		181	3-704-245-51	SCREW (1.4X3.5)	
164	X-3302-412-0	ARM ASSY, FWD		182	3-704-246-31	SCREW (P1.4X2.5)	
165	3-927-420-01	SPRING, TENSION		183	3-927-421-01	SPRING, TENSION	
166	X-3302-424-1	TABLE ASSY, REEL, TAKE-UP		184	3-927-423-01	BELT	
167	3-701-436-01	WASHER, 1.6		* 185	3-924-113-01	SPRING, DICT	
168	X-3302-414-0	TABLE ASSY, REEL, S		186	3-927-422-01	BELT	
* 169	3-302-559-00	ROLLER, GUIDE, H PC BOARD		* 187	X-3370-772-1	ARM ASSY, DICT	

SECTION 7 ELECTRICAL PARTS LIST

DC-JACK
LED
MAIN

NOTE:

- Due to standardization, replacements in the parts list may be different from the parts specified in the diagrams or the components used on the set.
- -XX and -X mean standardized parts, so they may have some difference from the original one.
- RESISTORS
All resistors are in ohms.
METAL: Metal-film resistor.
METAL OXIDE: Metal oxide-film resistor.
F: nonflammable

- Items marked "*" are not stocked since they are seldom required for routine service. Some delay should be anticipated when ordering these items.
- SEMICONDUCTORS
In each case, u: μ , for example:
uA.: μ A. uPA.: μ PA.
uPB.: μ PB. uPC.: μ PC. uPD.: μ PD.
- CAPACITORS
uF: μ F
- COILS
uH: μ H

When indicating parts by reference number, please include the board.

Ref. No.	Part No.	Description	Remark
*	1-657-826-11	DC-JACK BOARD *****	
		< CAPACITOR >	
C1	1-164-156-11	CERAMIC CHIP 0.1uF	25V
		< DIODE >	
D1	8-719-938-75	DIODE SB05-05CP (BM-577)	
		< JACK >	
J1	1-764-628-11	JACK, DC (POLARITY UNIFIED TYPE) (DC IN 3V)	

*	1-657-825-11	LED BOARD *****	
		< DIODE >	
D105	8-719-047-19	LED GL8PR29 (DICT/BATT) (BM-575)	
D105	8-719-047-19	LED GL8PR29 (DICT/BATT.) (BM-577)	
D106	8-719-047-19	LED GL8PR29 (BATT. . .) (BM-577)	
D107	8-719-047-19	LED GL8PR29 (BATT. . . .) (BM-577)	
		< RESISTOR >	
R156	1-216-833-11	METAL CHIP 10K 5% 1/16W	
R601	1-216-822-11	METAL CHIP 1.2K 5% 1/16W	(BM-577)
R602	1-216-815-11	METAL CHIP 330 5% 1/16W	(BM-577)
R603	1-216-818-11	METAL CHIP 560 5% 1/16W	(BM-577)
R604	1-216-814-11	METAL CHIP 270 5% 1/16W	(BM-577)
		< SWITCH >	
S11	1-570-395-11	SWITCH, LEAF (CASSETTE IN) (BM-577)	

Ref. No.	Part No.	Description	Remark
*	A-3016-730-A	MAIN BOARD, COMPLETE (BM-575)	
*	A-3016-735-A	MAIN BOARD, COMPLETE (BM-577) *****	
		< CAPACITOR >	
C101	1-164-156-11	CERAMIC CHIP 0.1uF	25V (BM-575)
C101	1-165-176-11	CERAMIC CHIP 0.047uF	10% 16V (BM-577)
C102	1-107-826-11	CERAMIC CHIP 0.1uF	10% 16V (BM-577)
C102	1-165-176-11	CERAMIC CHIP 0.047uF	10% 16V (BM-575)
C103	1-104-908-11	TANTAL. CHIP 47uF	20% 4V
C104	1-164-156-11	CERAMIC CHIP 0.1uF	25V
C105	1-162-968-11	CERAMIC CHIP 0.0047uF	10% 50V
C106	1-107-826-11	CERAMIC CHIP 0.1uF	10% 16V (BM-577)
C106	1-165-176-11	CERAMIC CHIP 0.047uF	10% 16V (BM-575)
C107	1-162-968-11	CERAMIC CHIP 0.0047uF	10% 50V
C108	1-162-970-11	CERAMIC CHIP 0.01uF	10% 25V
C109	1-107-826-11	CERAMIC CHIP 0.1uF	10% 16V (BM-575)
C109	1-165-176-11	CERAMIC CHIP 0.047uF	10% 16V (BM-577)
C110	1-164-156-11	CERAMIC CHIP 0.1uF	25V
C111	1-126-781-11	ELECT 220uF	20% 4V
C112	1-164-156-11	CERAMIC CHIP 0.1uF	25V (BM-577)
C112	1-164-677-11	CERAMIC CHIP 0.033uF	10% 16V (BM-575)
C113	1-162-964-11	CERAMIC CHIP 0.001uF	10% 50V
C114	1-164-156-11	CERAMIC CHIP 0.1uF	25V
C115	1-104-847-11	TANTAL. CHIP 22uF	20% 4V
C116	1-164-346-11	CERAMIC CHIP 1uF	16V
C117	1-164-156-11	CERAMIC CHIP 0.1uF	25V
C118	1-162-964-11	CERAMIC CHIP 0.001uF	10% 50V
C119	1-104-700-11	CERAMIC CHIP 0.027uF	10% 16V
C120	1-162-966-11	CERAMIC CHIP 0.0022uF	10% 50V (BM-577)

MAIN

Ref. No.	Part No.	Description	Remark
C120	1-162-967-11	CERAMIC CHIP	0.0033uF 10% 50V (BM-575)
C121	1-164-346-11	CERAMIC CHIP	1uF 16V
C122	1-135-201-11	TANTALUM CHIP	10uF 20% 4V
C123	1-126-781-11	ELECT	220uF 20% 4V
C124	1-162-970-11	CERAMIC CHIP	0.01uF 10% 25V
C125	1-165-176-11	CERAMIC CHIP	0.047uF 10% 16V
C126	1-164-156-11	CERAMIC CHIP	0.1uF 25V
C127	1-162-966-11	CERAMIC CHIP	0.0022uF 10% 50V
C128	1-162-964-11	CERAMIC CHIP	0.001uF 10% 50V
C129	1-104-847-11	TANTAL. CHIP	22uF 20% 4V
C130	1-162-927-11	CERAMIC CHIP	100PF 5% 50V
C131	1-126-779-91	ELECT	47uF 20% 4V
C132	1-135-180-21	TANTALUM CHIP	3.3uF 20% 6.3V
C133	1-135-091-91	TANTAL. CHIP	1uF 20% 16V
C134	1-162-964-11	CERAMIC CHIP	0.001uF 10% 50V
C135	1-162-964-11	CERAMIC CHIP	0.001uF 10% 50V
C136	1-164-730-11	CERAMIC CHIP	0.0012uF 10% 50V
C137	1-162-977-11	CERAMIC CHIP	0.0018uF 10% 50V
C138	1-104-932-11	CERAMIC CHIP	10uF 16V (BM-577)
C138	1-135-201-11	TANTALUM CHIP	10uF 20% 4V (BM-575)
C139	1-162-964-11	CERAMIC CHIP	0.001uF 10% 50V
C140	1-162-970-11	CERAMIC CHIP	0.01uF 10% 25V
C141	1-164-346-11	CERAMIC CHIP	1uF 16V
C142	1-164-346-11	CERAMIC CHIP	1uF 16V
C143	1-162-970-11	CERAMIC CHIP	0.01uF 10% 25V
C144	1-164-156-11	CERAMIC CHIP	0.1uF 25V
C145	1-162-968-11	CERAMIC CHIP	0.0047uF 10% 50V
C146	1-104-847-11	TANTAL. CHIP	22uF 20% 4V
C147	1-104-908-11	TANTAL. CHIP	47uF 20% 4V
C148	1-164-730-11	CERAMIC CHIP	0.0012uF 10% 50V
C149	1-162-967-11	CERAMIC CHIP	0.0033uF 10% 50V
C150	1-104-847-11	TANTAL. CHIP	22uF 20% 4V (BM-577)
C151	1-107-826-11	CERAMIC CHIP	0.1uF 10% 16V (BM-577)
C152	1-107-826-11	CERAMIC CHIP	0.1uF 10% 16V (BM-577)
C153	1-135-201-11	TANTALUM CHIP	10uF 20% 4V (BM-577)
C154	1-162-964-11	CERAMIC CHIP	0.001uF 10% 50V
C155	1-164-677-11	CERAMIC CHIP	0.033uF 10% 16V
C156	1-162-974-11	CERAMIC CHIP	0.01uF 50V
C157	1-104-908-11	TANTAL. CHIP	47uF 20% 4V
C158	1-135-201-11	TANTALUM CHIP	10uF 20% 4V (BM-575)
C159	1-164-346-11	CERAMIC CHIP	1uF 16V

Ref. No.	Part No.	Description	Remark
		< DIODE >	
D101	8-719-941-23	DIODE DA204U	
D102	8-719-941-23	DIODE DA204U	
D103	8-719-948-98	DIODE FMN1-T-148	
D104	8-719-801-78	DIODE 1SS184	
		< IC >	
IC101	8-759-701-02	IC NJM2073M	
IC102	8-759-701-51	IC NJM2072M	
IC103	8-759-804-43	IC LA5521M	
IC104	8-759-701-51	IC NJM2072M	
		< JACK >	
J2	1-766-156-11	JACK (EAR)	
J3	1-766-156-11	JACK (MIC)	
		< JUMPER RESISTOR >	
JP101	1-216-296-00	METAL CHIP 0 5% 1/8W (BM-575)	
		< PHOTO REFLECTOR >	
PH101	8-749-011-74	PHOTO REFLECTOR SPI-335-74BC	
		< TRANSISTOR >	
Q101	8-729-117-32	TRANSISTOR 2SC4177	
Q102	8-729-117-32	TRANSISTOR 2SC4177	
Q103	8-729-800-37	TRANSISTOR 2SD1048-X7	
Q104	8-729-117-32	TRANSISTOR 2SC4177	
Q105	8-729-805-91	TRANSISTOR 2SA1563	
Q106	8-729-800-37	TRANSISTOR 2SD1048-X7	
Q107	8-729-805-94	TRANSISTOR 2SC4047	
Q108	8-729-805-94	TRANSISTOR 2SC4047	
Q109	8-729-807-87	TRANSISTOR 2SB1295-UL6	
Q110	8-729-117-32	TRANSISTOR 2SC4177	
Q111	8-729-805-91	TRANSISTOR 2SA1563	
Q112	8-729-807-87	TRANSISTOR 2SB1295-UL6	
Q113	8-729-805-94	TRANSISTOR 2SC4047	
Q114	8-729-901-06	TRANSISTOR DTA144EK	
Q115	8-729-805-94	TRANSISTOR 2SC4047	
Q116	8-729-901-06	TRANSISTOR DTA144EK	
Q117	8-729-117-32	TRANSISTOR 2SC4177	
Q118	8-729-117-32	TRANSISTOR 2SC4177	
Q119	8-729-117-32	TRANSISTOR 2SC4177	
Q120	8-729-805-91	TRANSISTOR 2SA1563	
Q121	8-729-805-91	TRANSISTOR 2SA1563	
Q122	8-729-117-32	TRANSISTOR 2SC4177	
Q123	8-729-216-22	TRANSISTOR 2SA1162-G	
Q124	8-729-117-32	TRANSISTOR 2SC4177	
Q125	8-729-117-32	TRANSISTOR 2SC4177 (BM-577)	

Ref. No.	Part No.	Description	Remark
Q126	8-729-117-32	TRANSISTOR	2SC4177 (BM-577)
Q127	8-729-805-91	TRANSISTOR	2SA1563 (BM-577)
Q128	8-729-117-32	TRANSISTOR	2SC4177 (BM-577)
< RESISTOR >			
R101	1-216-820-11	METAL CHIP	820 5% 1/16W
R102	1-216-829-11	METAL CHIP	4.7K 5% 1/16W
R103	1-216-835-11	METAL CHIP	15K 5% 1/16W
R104	1-216-827-11	METAL CHIP	3.3K 5% 1/16W
R104	1-216-828-11	METAL CHIP	3.9K 5% 1/16W (BM-577) (BM-575)
R105	1-216-824-11	METAL CHIP	1.8K 5% 1/16W
R106	1-216-841-11	METAL CHIP	47K 5% 1/16W
R107	1-216-841-11	METAL CHIP	47K 5% 1/16W
R108	1-216-817-11	METAL CHIP	470 5% 1/16W
R109	1-216-826-11	METAL CHIP	2.7K 5% 1/16W
R110	1-216-827-11	METAL CHIP	3.3K 5% 1/16W
R111	1-216-823-11	METAL CHIP	1.5K 5% 1/16W
R112	1-216-823-11	METAL CHIP	1.5K 5% 1/16W (BM-575)
R112	1-216-825-11	METAL CHIP	2.2K 5% 1/16W (BM-577)
R113	1-216-841-11	METAL CHIP	47K 5% 1/16W
R114	1-216-833-11	METAL CHIP	10K 5% 1/16W
R115	1-216-825-11	METAL CHIP	2.2K 5% 1/16W (BM-577)
R115	1-216-833-11	METAL CHIP	10K 5% 1/16W (BM-575)
R116	1-216-841-11	METAL CHIP	47K 5% 1/16W
R117	1-216-813-11	METAL CHIP	220 5% 1/16W
R118	1-216-821-11	METAL CHIP	1K 5% 1/16W
R119	1-216-809-11	METAL CHIP	100 5% 1/16W
R120	1-216-820-11	METAL CHIP	820 5% 1/16W
R121	1-216-814-11	METAL CHIP	270 5% 1/16W
R122	1-216-812-11	METAL CHIP	180 5% 1/16W
R123	1-216-852-11	METAL CHIP	390K 5% 1/16W
R124	1-216-793-11	METAL GLAZE	4.7 5% 1/16W
R125	1-216-801-11	METAL CHIP	22 5% 1/16W
R126	1-216-833-11	METAL CHIP	10K 5% 1/16W
R127	1-216-833-11	METAL CHIP	10K 5% 1/16W
R128	1-216-831-11	METAL CHIP	6.8K 5% 1/16W
R129	1-216-833-11	METAL CHIP	10K 5% 1/16W
R130	1-216-835-11	METAL CHIP	15K 5% 1/16W
R131	1-216-833-11	METAL CHIP	10K 5% 1/16W
R132	1-216-817-11	METAL CHIP	470 5% 1/16W
R133	1-216-841-11	METAL CHIP	47K 5% 1/16W
R134	1-216-820-11	METAL CHIP	820 5% 1/16W
R135	1-216-805-11	METAL CHIP	47 5% 1/16W
R136	1-216-841-11	METAL CHIP	47K 5% 1/16W

Ref. No.	Part No.	Description	Remark
R137	1-218-269-11	METAL GLAZE	360 5% 1/16W
R138	1-216-822-11	METAL CHIP	1.2K 5% 1/16W
R139	1-216-837-11	METAL CHIP	22K 5% 1/16W
R140	1-216-061-00	METAL CHIP	3.3K 5% 1/10W
R141	1-216-823-11	METAL CHIP	1.5K 5% 1/16W
R142	1-216-823-11	METAL CHIP	1.5K 5% 1/16W
R143	1-216-818-11	METAL CHIP	560 5% 1/16W
R144	1-216-853-11	METAL CHIP	470K 5% 1/16W
R145	1-216-852-11	METAL CHIP	390K 5% 1/16W
R146	1-216-845-11	METAL CHIP	100K 5% 1/16W
R147	1-216-833-11	METAL CHIP	10K 5% 1/16W
R148	1-216-841-11	METAL CHIP	47K 5% 1/16W
R149	1-216-821-11	METAL CHIP	1K 5% 1/16W
R150	1-216-809-11	METAL CHIP	100 5% 1/16W
R151	1-216-843-11	METAL CHIP	68K 5% 1/16W
R152	1-216-817-11	METAL CHIP	470 5% 1/16W
R153	1-216-829-11	METAL CHIP	4.7K 5% 1/16W
R154	1-216-857-11	METAL CHIP	1M 5% 1/16W
R155	1-216-817-11	METAL CHIP	470 5% 1/16W
R157	1-216-826-11	METAL CHIP	2.7K 5% 1/16W
R158	1-216-811-11	METAL CHIP	150 5% 1/16W (BM-575)
R158	1-216-815-11	METAL CHIP	330 5% 1/16W (BM-577)
R159	1-216-811-11	METAL CHIP	150 5% 1/16W (BM-575)
R159	1-216-814-11	METAL CHIP	270 5% 1/16W (BM-577)
R160	1-216-835-11	METAL CHIP	15K 5% 1/16W
R161	1-216-843-11	METAL CHIP	68K 5% 1/16W (BM-577)
R162	1-216-847-11	METAL CHIP	150K 5% 1/16W (BM-577)
R163	1-216-853-11	METAL CHIP	470K 5% 1/16W
R164	1-216-845-11	METAL CHIP	100K 5% 1/16W (BM-577)
R165	1-216-853-11	METAL CHIP	470K 5% 1/16W (BM-577)
R166	1-216-852-11	METAL CHIP	390K 5% 1/16W (BM-577)
R167	1-216-823-11	METAL CHIP	1.5K 5% 1/16W (BM-577)
R168	1-216-818-11	METAL CHIP	560 5% 1/16W (BM-577)
R169	1-216-809-11	METAL CHIP	100 5% 1/16W (BM-577)
R170	1-216-154-00	METAL GLAZE	15 5% 1/8W (BM-577)
R171	1-216-154-00	METAL GLAZE	15 5% 1/8W (BM-577)
R172	1-216-813-11	METAL CHIP	220 5% 1/16W

MAIN

Ref. No.	Part No.	Description	Remark
R173	1-216-807-11	METAL CHIP 68 5%	1/16W (BM-575)
R174	1-216-837-11	METAL CHIP 22K 5%	1/16W (BM-575)
R175	1-216-814-11	METAL CHIP 270 5%	1/16W (BM-575)
R175	1-216-822-11	METAL CHIP 1.2K 5%	1/16W (BM-577)
R176	1-216-200-11	METAL GLAZE 1.2K 5%	1/8W
R177	1-216-841-11	METAL CHIP 47K 5%	1/16W
< SWITCH >			
S1	1-762-456-11	SWITCH, SLIDE (REC/PB)	
S2	1-572-922-11	SWITCH, SLIDE (MIC SENS)	
S3	1-571-277-31	SWITCH, SLIDE (TAPE SPEED)	
S4	1-572-922-11	SWITCH, SLIDE (FAST PB)	
S5	1-571-275-31	SWITCH, SLIDE (VOR)	
S6	1-572-288-11	SWITCH, PUSH (FF/CUE)	
S7	1-553-817-00	SWITCH, LEAF (POWER)	
S8	1-572-688-11	SWITCH, PUSH (BATTERY CHARGE) (BM-577)	
S9	1-572-688-11	SWITCH, PUSH (B.SPACE)	
S10	1-692-088-11	SWITCH, TACTILE (E-INDEX) (BM-577)	
< TRANSFORMER >			
T101	1-433-286-11	TRANSFORMER, BIAS OSCILLATION	
< THERMISTOR (POSITIVE) >			
THP101	1-808-956-11	THERMISTOR, POSITIVE	
< VARIABLE RESISTOR >			
VR101	1-223-749-11	RES, VAR, CARBON 10K/10K (VOL)	
VR102	1-238-089-11	RES, ADJ, CERMET 4.7K	
VR103	1-238-088-11	RES, ADJ, CERMET 2.2K	

MISCELLANEOUS			

105	1-548-516-00	TIMER, TAPE	
HD1	1-500-271-11	HEAD, MAGNETIC (REC/PB/ERASE) (BM-575)	
HD1	1-543-725-11	HEAD, MAGNETIC (REC/PB) (BM-577)	
HE1	8-825-772-01	ESF194-62G (ERASE HEAD) (BM-577)	
M1	A-3042-785-A	MOTOR ASSY	
MIC1	1-542-197-11	MICROPHONE, ELECTRET CONDENSER	
SP1	1-504-961-11	SPEAKER	

Ref. No.	Part No.	Description	Remark

HARDWARE LIST			

#1	7-624-101-04	STOP RING 1.2 (E TYPE)	
#2	7-627-451-07	SCREW, PRECISION +K 1.4X1.6	
#3	7-627-451-08	SCREW, PRECISION +K 1.4X1.6	
#4	7-627-551-17	SCREW, PRECISION +P 1.4X2	
#5	7-627-551-27	SCREW, PRECISION +P 1.4X2.5	
#6	7-627-551-47	SCREW, PRECISION +P 1.4X1.4	
#7	7-627-850-07	SCREW, PRECISION +P 1.4X2	
#8	7-627-850-08	SCREW, PRECISION +P 1.4X2	
#9	7-627-850-17	SCREW, PRECISION +P 1.4X2.5	
#10	7-627-850-47	SCREW, PRECISION +P 1.4X1.6	
#11	7-627-850-97	SCREW, PRECISION +P 1.4X2.2	
#12	7-671-111-11	BALL, STEEL 1.5MM	
#13	7-671-155-01	BALL, STEEL 3MM	

ACCESSORIES & PACKING MATERIALS			

3-800-079-13		MANUAL, INSTRUCTION (ENGLISH,FRENCH)	(AEP)
3-800-079-22		MANUAL, INSTRUCTION (ENGLISH) (US)	
3-800-079-43		MANUAL, INSTRUCTION (GERMAN,DUTCH)	(AEP)
3-927-586-01		CASE, CARRYING (BM-577)	

BM-575/577

SONY[®]

*US Model
AEP Model*

SERVICE MANUAL

Ver. 1.1 2006. 10

SUPPLEMENT-2

File this supplement with the service manual.

Subject : Specification change of BM-575

Change to the specifications are made to implement for the model with the serial No. 0100001 and later (US model) or 0101751 and later (AEP model).

Check the serial No. when servicing or inspecting the set.

Mechanical adjustments, electrical adjustments, printed wiring boards, schematic diagram, exploded view and electrical parts list of new type are described in this supplement-2.

1. MECHANICAL ADJUSTMENTS

PRECAUTION

1. Clean the following parts with a denatured alcohol moistened swab:
 record/playback/erase head pinch roller
 rubber belts capstan idlers
 2. Demagnetize the record/playback/erase head with a head demagnetizer.
 3. Do not use a magnetized screwdriver for the adjustments.
 4. After the adjustments, apply suitable locking compound to the parts adjusted.
 5. The adjustments should be performed with the rated power supply voltage (dc 2.5 V) unless otherwise noted.
- Switches and control should be set as follows unless otherwise specified.
- MIC SENS selector : CONF
 TAPE SPEED selector : 2.4 cm
 FAST PB switch : OFF
 VOR switch : OFF
 VOL control : mechanical center

Torque Measurement

Mode	Torque meter (Cassette type)	Meter reading
LISTEN	CQ-103M	5 to 12 g•cm (0.069 to 0.167 oz•inch)
FF/CUE	CQ-201M	more than 5 g•cm (more than 0.069 oz•inch)
B. SPACE	CQ-201M	more than 14 g•cm (more than 0.194 oz•inch)

Tape Tension Measurement

Mode	Tension meter (Cassette type)	Meter reading
LISTEN	CQ-403M	25 to 55 g (0.88 to 1.94 oz)

Timing Adjustment

1. Take-up reel spindle should rotate at the same time as pinch roller or earlier than pinch roller in STOP to LISTEN/DICT mode.
 Confirm that the pinch roller presses to capstan and they rotate.
2. When they are not correctly rotate, adjust the place of adjustment plate so that it is wide.

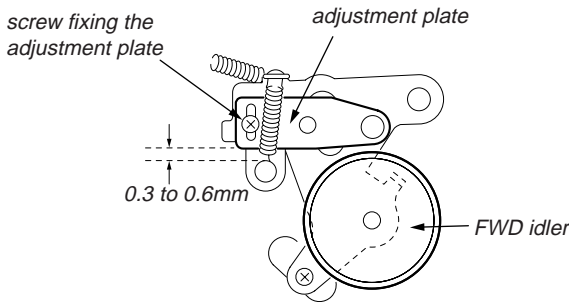

2. ELECTRICAL ADJUSTMENTS

PRECAUTION

1. Demagnetize the record/playback/erase head with a head demagnetizer.
 2. Do not use a magnetized screwdriver for the adjustments.
 3. After the adjustments, apply suitable locking compound to the parts adjusted.
 4. The adjustments should be performed with the rated power supply voltage (dc 2.5 V) unless otherwise noted.
 5. The adjustments should be performed in the order given in this service manual. (As a general rule, playback circuit adjustment should be completed before performing recording circuit adjustment.)
- Switches and control should be set as follows unless otherwise specified.
- MIC SENS selector : CONF
 TAPE SPEED selector : 2.4 cm
 FAST PB switch : OFF
 VOR switch : OFF
 VOL control : mechanical center

Test Tape

Type	Signal	Used for
WS-24	3 kHz, -10 dB	Tape Speed (2.4 cm) Adjustment
WS-12	3 kHz, -10 dB	Tape Speed (1.2 cm) Adjustment
S-2-A030A	3 kHz, -20 dB	Head Azimuth Adjustment

Tape Speed (2.4 cm) Adjustment

Setting:
 TAPE SPEED selector: 2.4 cm

- Procedure:**
1. Mode: LISTEN

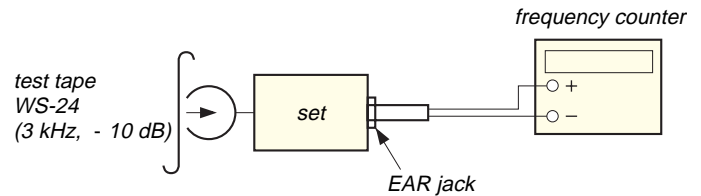

2. Adjust VR102 so that the frequency counter reads 2,990 to 3,010 Hz.

Adjustment Location: See page 3.

Tape Speed (1.2 cm) Adjustment

Setting:
 TAPE SPEED selector: 1.2 cm

- Procedure:**
1. Mode: LISTEN

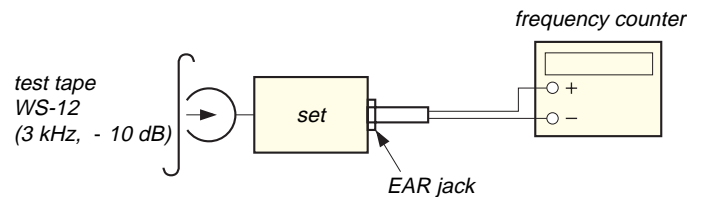

2. Adjust VR103 so that the frequency counter reads 2,990 to 3,010 Hz.

Adjustment Location: See page 3.

Adjustment Location:

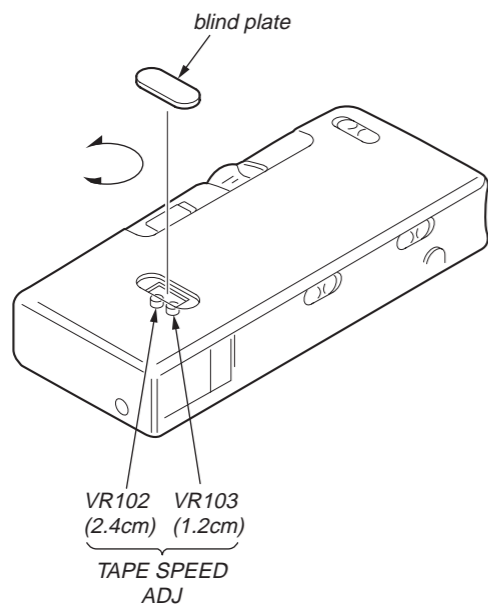

Record/playback Head Azimuth Adjustment

Procedure:

1. Mode: LISTEN

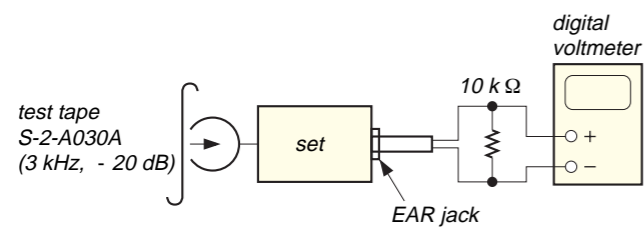

2. Turn the adjustment screw for maximum digital voltmeter reading.

Note: Several peaks may appear, but take the maximum.

Adjustment Location:

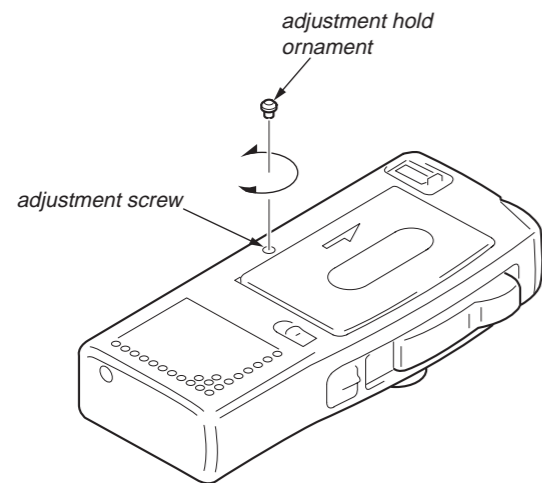

Record Bias Adjustment

Setting:

TAPE SPEED selector: 2.4 cm

Procedure:

1. Mode: DICT (record)

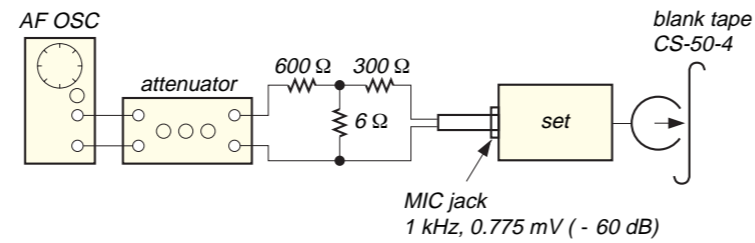

2. Mode: LISTEN (playback)

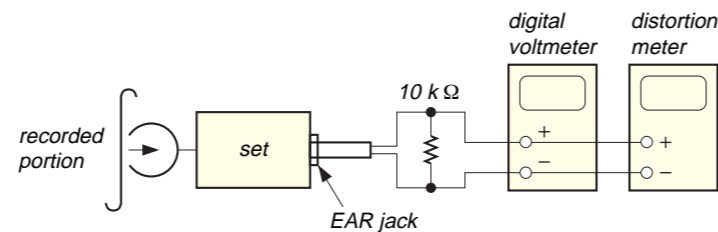

3. LISTEN (playback) the signal recorded in step 1.
4. Turn the VOL control so that the digital voltmeter reads within 0 dB.
Confirm that the distortion meter reads within adjustment limits.
5. Set the TAPE SPEED selector to 1.2 cm and repeat steps 1 to 4.
6. If the adjustment limits are not satisfied, soldering the tap as follows.

Adjustment limits:

tape speed	distortion
2.4 cm/s	within 10%
1.2 cm/s	within 14%

Soldering Point: main board (conductor side)

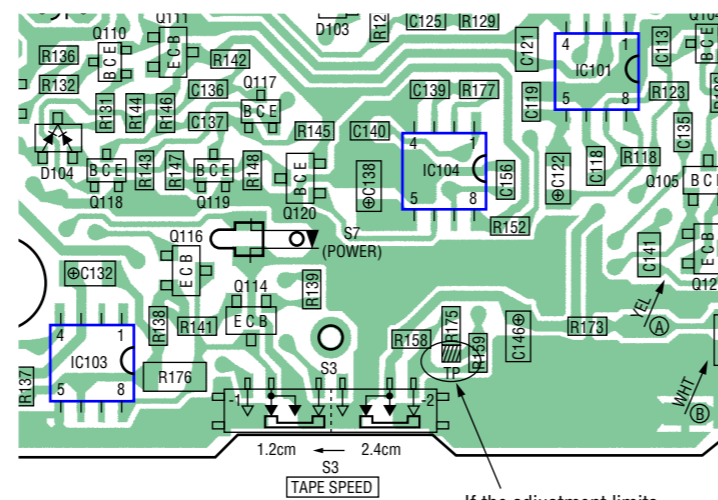

If the adjustment limits are not satisfied, soldering the tap.

3. DIAGRAMS

• NOTE FOR PRINTED WIRING BOARDS AND SCHEMATIC DIAGRAMS

THIS NOTE IS COMMON FOR PRINTED WIRING BOARDS AND SCHEMATIC DIAGRAMS. (In addition to this, the necessary note is printed in each block.)

for schematic diagram:

- All capacitors are in μF unless otherwise noted. (p: pF) 50 WV or less are not indicated except for electrolytics and tantalums.
- All resistors are in Ω and $1/4$ W or less unless otherwise specified.
- Δ : internal component.
- \square : panel designation.
- --- : B+ Line.
- --- : adjustment for repair.
- Power voltage is dc 3 V and fed with regulated dc power supply from external power voltage jack.
- Voltage is dc with respect to ground under no-signal conditions.
- no mark : LISTEN (2.4 cm)
- FS : FF/CUE: ON
- BS : B.SPACE: ON
- REC : DICT
- Voltages are taken with a VOM (Input impedance 10 M Ω). Voltage variations may be noted due to normal production tolerances.
- Signal path.
- --- : PB (LISTEN)
- --- : REC (DICT)

for printed wiring boards:

- --- : parts extracted from the component side.
- --- : parts extracted from the conductor side.
- --- : Pattern from the side which enables seeing. (The other layer's patterns are not indicated.)

Caution:

Pattern face side: Parts on the pattern face side seen from (Conductor Side) the pattern face are indicated.
Parts face side: Parts on the parts face side seen from (Component Side) the parts face are indicated.

3-1. PRINTED WIRING BOARDS

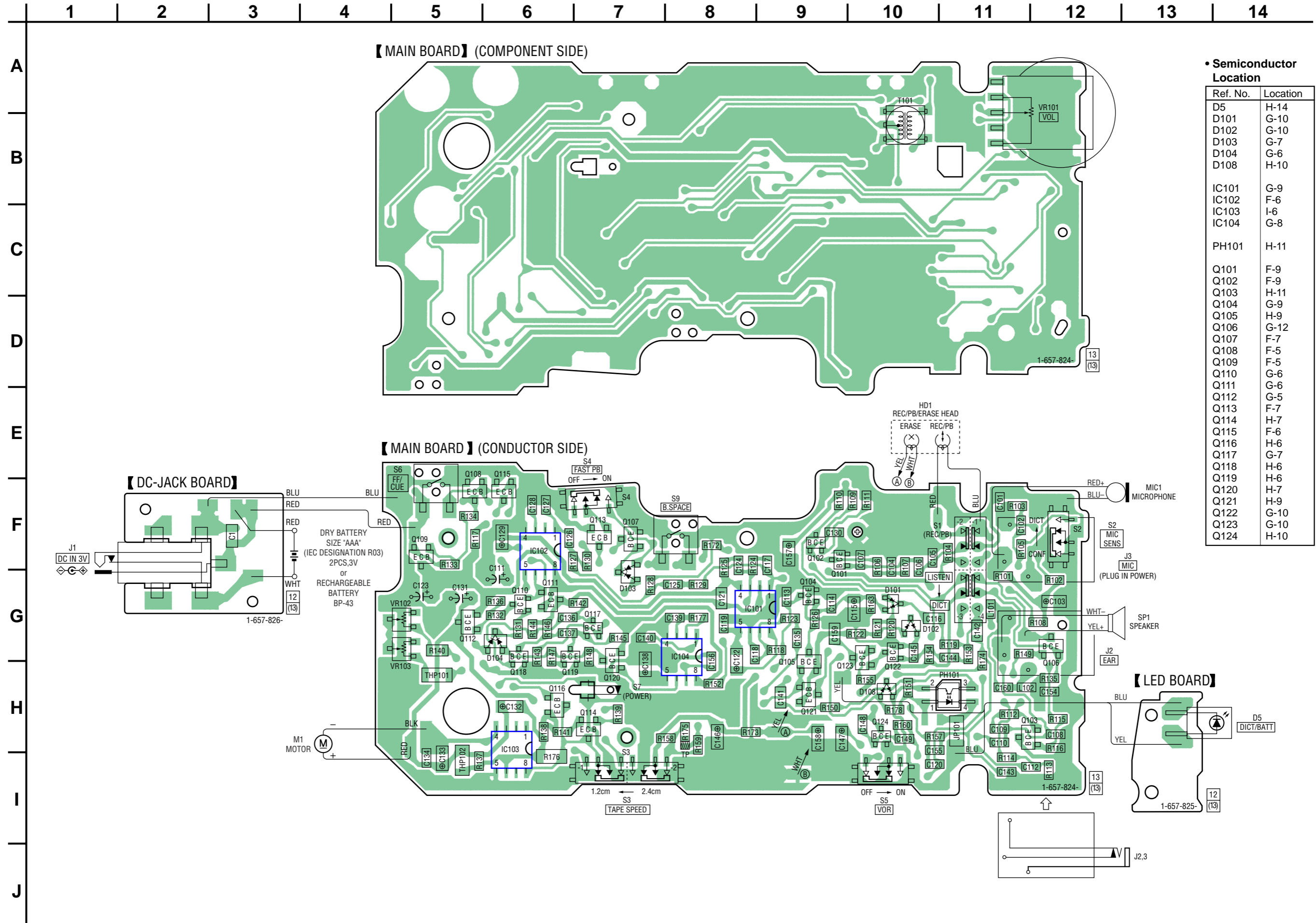

3-2. SCHEMATIC DIAGRAM

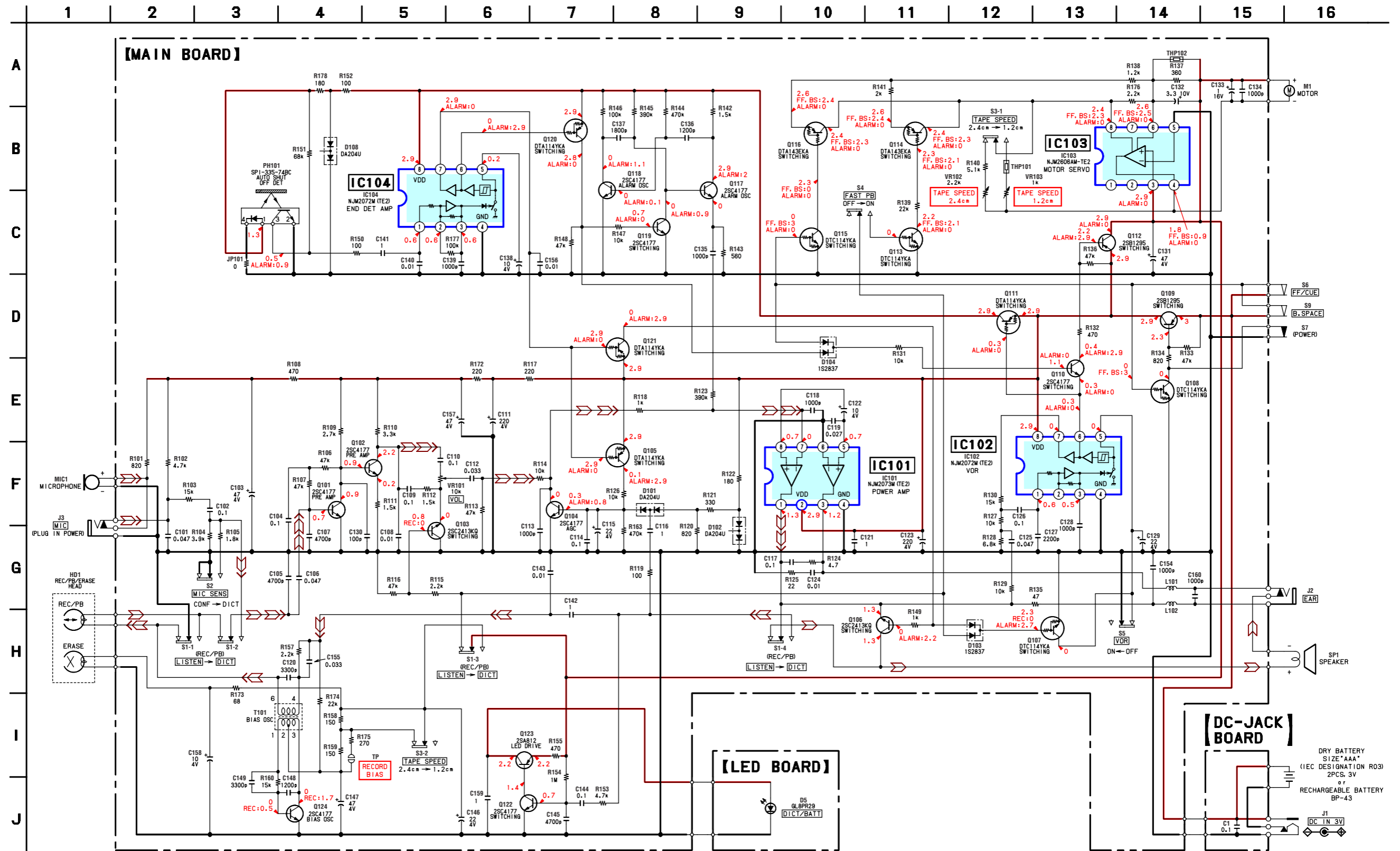

4. EXPLODED VIEWS

NOTE:

- The mechanical parts with no reference number in the exploded views are not supplied.
- Items marked "*" are not stocked since they are seldom required for routine service. Some delay should be anticipated when ordering these items.

• Color Indication of Appearance Parts

Example :

KNOB, BALANCE (WHITE) ... (RED)

↑ ↑
Parts Color Cabinet's Color

- Accessories are given in the last of this parts list.

4-1. CABINET SECTION

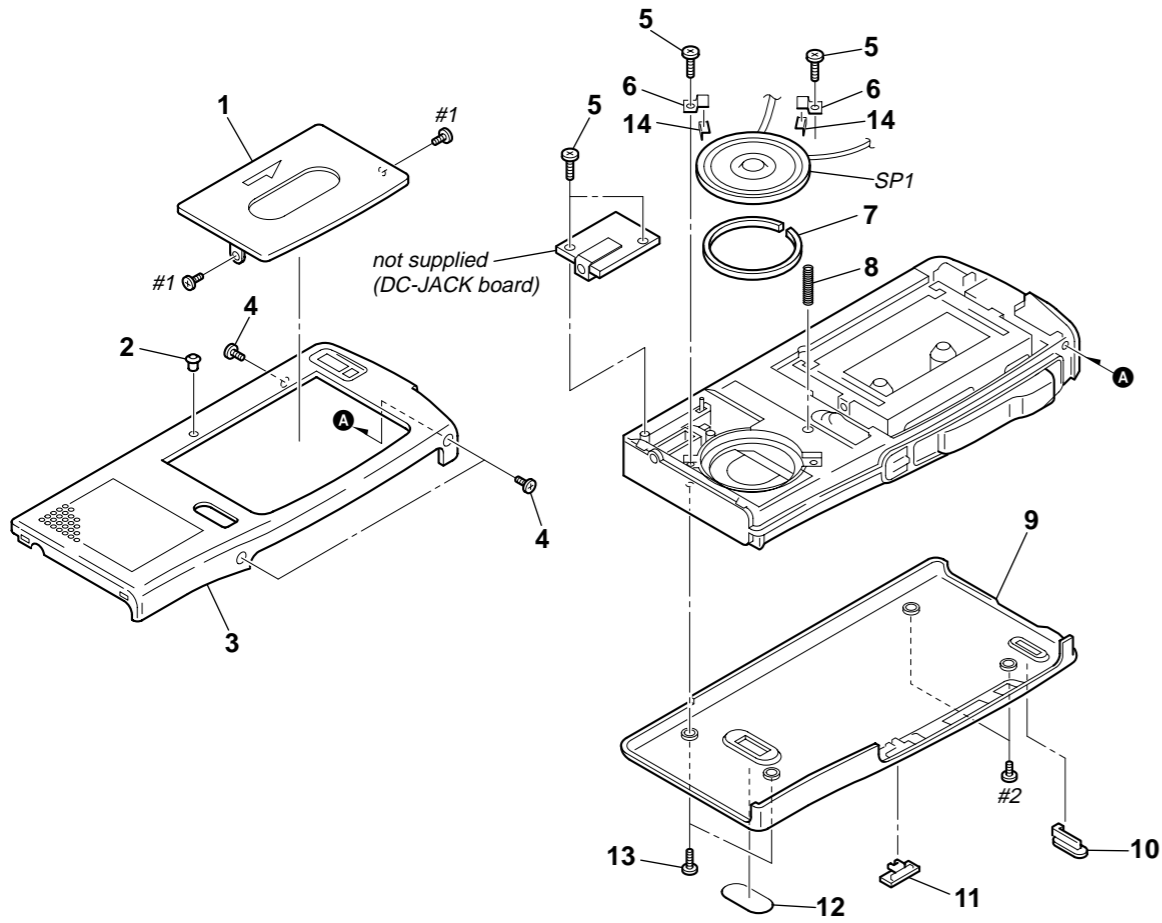

4-2. CHASSIS SECTION

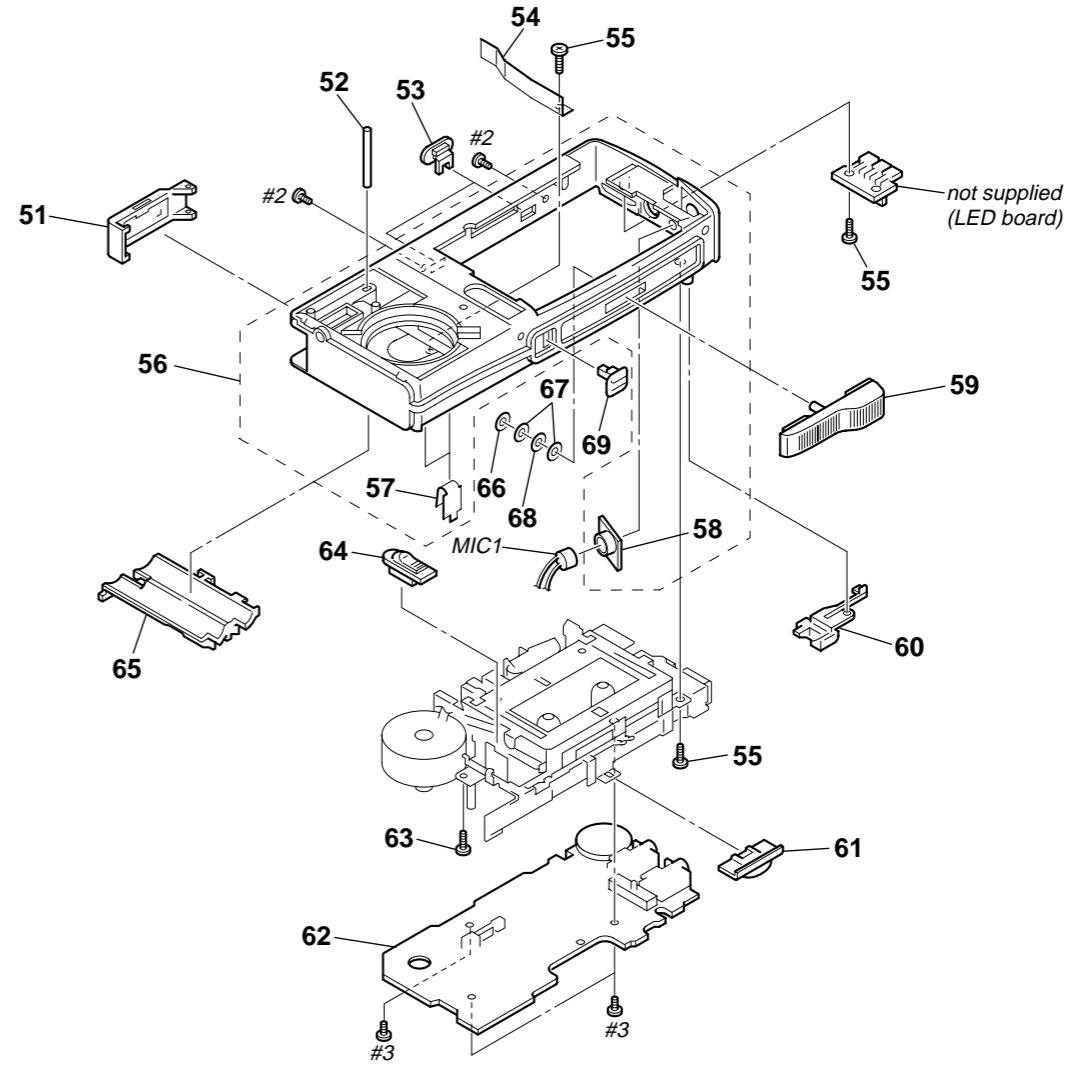

Ref. No.	Part No.	Description	Remark
1	A-3042-794-A	LID (CASSETTE) ASSY	
2	3-578-232-21	ORNAMENT, ADJUSTMENT HOLE	
3	A-3042-786-A	CABINET (FRONT) ASSY	
4	3-254-135-01	SCREW (B1.4)	
5	3-309-597-01	SCREW (1.4), TAPPING	
6	3-927-397-01	BRACKET, SP	
7	3-927-396-01	CUSHION, SP	
8	3-927-395-01	SPRING, COMPRESSION	
9	3-926-697-11	CABINET (REAR)	

Ref. No.	Part No.	Description	Remark
10	3-927-405-01	KNOB (MIC SENS)	
11	3-927-406-01	KNOB (FAST PB)	
12	3-927-400-02	PLATE, BLIND	
13	3-080-204-11	SCREW, TAPPING, P2	
14	2-629-906-01	CUSHION	
	SP1	1-826-070-11	SPEAKER (2.8cm)
	#1	7-627-451-08	SCREW, PRECISION +K 1.4X1.6
	#2	7-627-850-08	SCREW, PRECISION +P 1.4X2

Ref. No.	Part No.	Description	Remark
51	A-3042-793-A	LID ASSY, BATTERY CASE	
52	3-927-394-01	SHAFT (BATTERY CASE LID)	
53	3-927-398-01	KNOB (TAPE SPEED)	
54	3-927-393-01	SPRING, BATTERY CASE LID	
55	3-309-597-01	SCREW (1.4), TAPPING	
56	A-3042-788-A	CABINET (MIDDLE) ASSY	
57	3-927-413-01	SPRING, BATTERY	
58	3-306-145-01	HOLDER (MICROPHONE)	
59	A-3042-792-A	BUTTON ASSY, CONTROL	
60	3-927-404-01	BUTTON (E-INDEX)	
61	3-927-403-01	KNOB (FF)	

Ref. No.	Part No.	Description	Remark
62	A-1119-343-A	MAIN BOARD, COMPLETE	
63	3-309-597-61	SCREW (1.4X6), TAPPING	
64	3-927-399-01	BUTTON (EJECT)	
65	3-927-499-01	COVER, BATTERY	
66	3-321-813-01	WASHER, COTTER POLYETHYLENE	
67	3-701-437-01	WASHER	
68	3-557-857-01	CUSHION, VIBRATION PREVENTION	
69	3-927-392-01	BUTTON (LOCK)	
MIC1	1-542-197-11	MICROPHONE, ELECTRET CONDENSER	
#2	7-627-850-08	SCREW, PRECISION +P 1.4X2	
#3	7-627-850-07	SCREW, PRECISION +P 1.4X2	

4-3. MECHANISM DECK SECTION (1)
(MB-575-50)

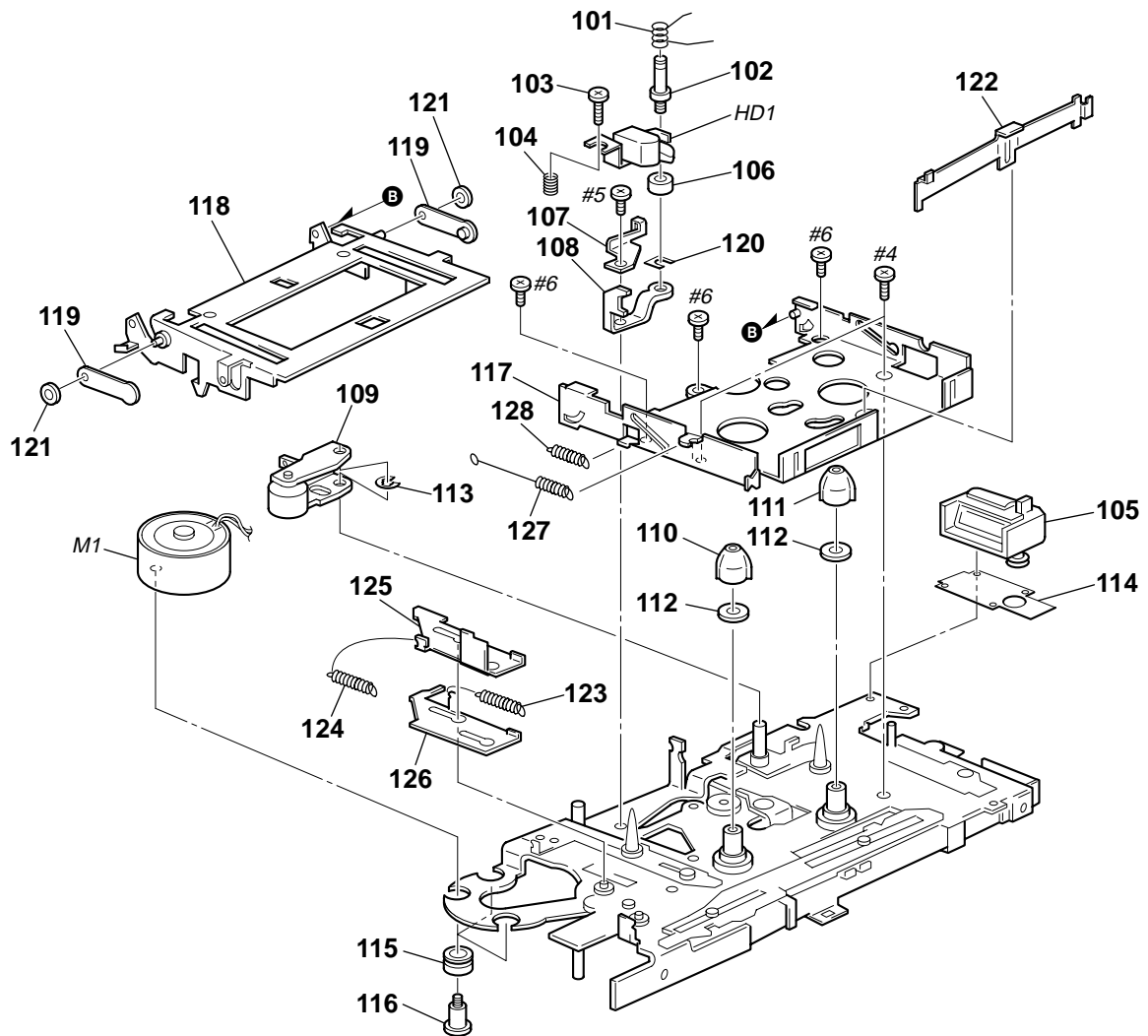

Ref. No.	Part No.	Description	Remark	Ref. No.	Part No.	Description	Remark
101	3-306-149-01	SPRING, TORSION		118	X-3370-775-1	HOLDER ASSY, LID	
102	3-306-165-01	SHAFT (HEAD FITTING)		119	X-3370-773-1	ARM ASSY	
103	3-704-375-01	SCREW (1.7X5.5), (+P), PRECISION		120	3-578-138-01	SHIM (t=0.1)	
104	3-570-558-00	SPRING, COMPRESSION		120	3-578-138-11	SHIM (t=0.2)	
105	1-548-516-00	TIMER, TAPE		121	3-315-384-11	WASHER, STOPPER	
106	3-306-164-01	SPACER (HEAD)		122	3-927-428-01	RETAINER (A), CASSETTE	
107	3-302-476-01	CLAMP		123	3-927-424-01	SPRING, TENSION	
108	3-302-464-02	GUIDE, TAPE		124	3-927-425-01	SPRING, TENSION	
109	X-3302-409-0	PINCH LEVER ASSY		125	3-924-116-01	LEVER, EJECT	
110	3-302-459-00	CLAW (S), REEL		126	3-924-115-01	LEVER, LOCK	
111	3-302-460-00	CLAW (T), REEL		127	3-927-427-01	SPRING, TENSION	
112	3-701-436-01	WASHER, 1.6		128	3-927-426-01	SPRING, TENSION	
113	3-578-255-11	RING (E1.5), RETAINING		HD1	1-500-271-11	HEAD, MAGNETIC (REC/PB/ERASE)	
114	3-928-722-01	PLATE, COUNTER		M1	X-3381-211-1	MOTOR ASSY	
115	3-570-770-00	CUSHION (A), MOTOR		#4	7-627-451-07	SCREW, PRECISION +K 1.4X1.6	
116	3-033-204-02	SHAFT, MOTOR FITTING		#5	7-627-551-17	SCREW, PRECISION +P 1.4X2	
117	X-3370-774-1	PANEL ASSY, SUB		#6	7-627-551-47	SCREW, PRECISION +P 1.4X1.4	

4-4. MECHANISM DECK SECTION (2)
(MB-575-50)

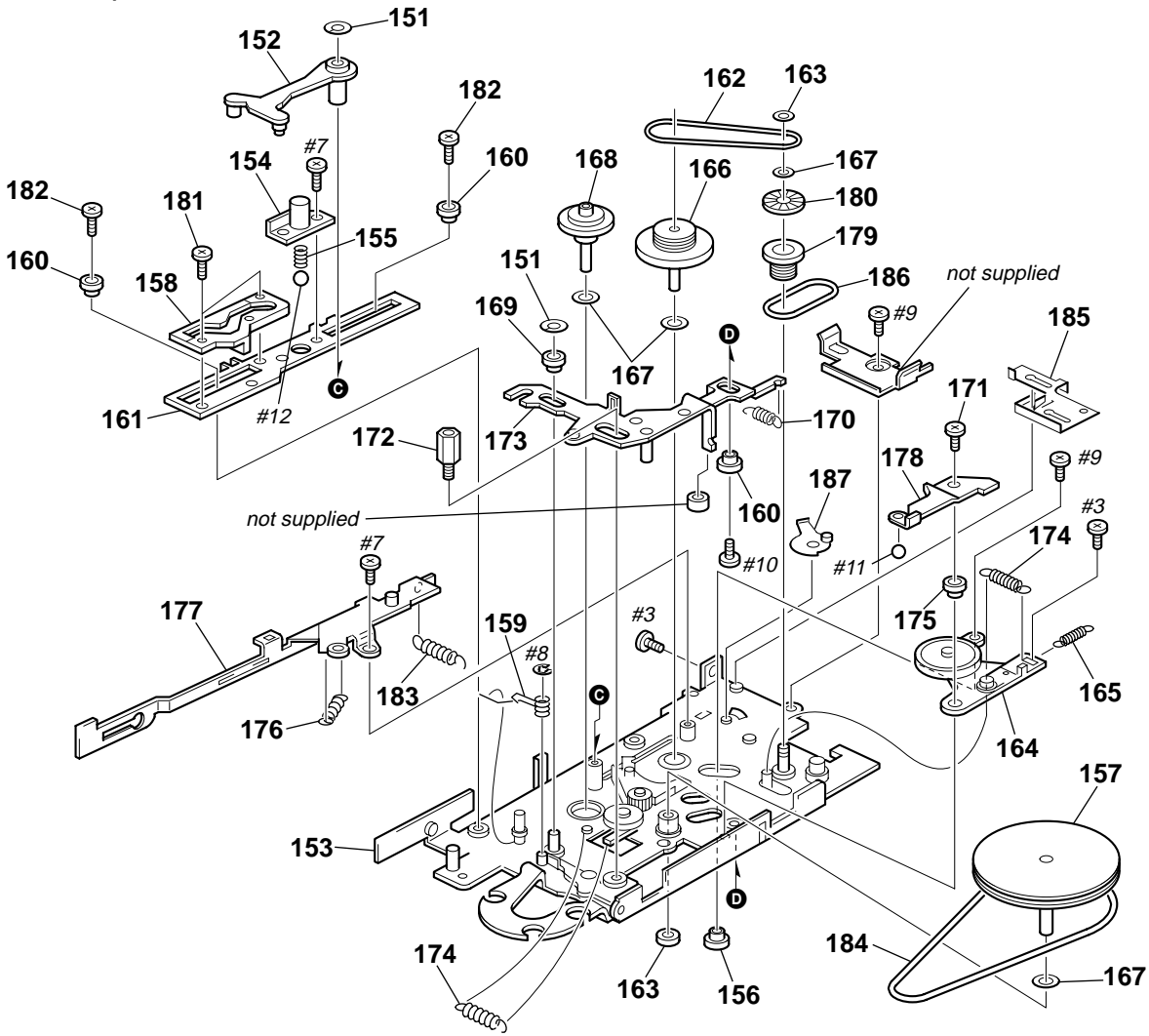

Ref. No.	Part No.	Description	Remark	Ref. No.	Part No.	Description	Remark
151	3-311-815-11	WASHER, POLYETHYLENE		173	X-3370-771-1	CHASSIS ASSY, HEAD	
152	X-3306-122-2	ARM ASSY, JOINT		174	3-561-634-00	SPRING, TENSION	
153	X-3370-769-1	CHASSIS ASSY, MECHANICAL		175	3-302-541-00	BUSHING, FWD ARM	
154	3-018-105-01	RETAINER, SPRING		176	3-527-188-00	SPRING, TENSION	
155	3-302-567-01	SPRING (STEEL BALL), COMPRESSION		177	X-3370-770-1	BRACKET ASSY, FF	
156	3-302-495-00	GUIDE, ARM, FWD		178	3-302-462-02	RETAINER, H CHASSIS	
157	X-3306-111-3	FLYWHEEL ASSY		179	3-927-429-01	PULLEY, RELAY	
158	3-306-197-01	GUIDE (B), CONTROL		180	3-927-430-01	REFLECTOR	
159	3-302-490-00	SPRING, BS RETURN		181	3-704-245-51	SCREW (1.4)	
160	3-302-536-00	GUIDE, CONTROL LEVER		182	3-704-246-31	SCREW (P1.4X2.5)	
161	3-924-114-01	LEVER, CONTROL		183	3-927-421-01	SPRING, TENSION	
162	3-561-645-00	BELT, C		184	3-353-951-01	BELT	
163	3-315-384-11	WASHER, STOPPER		185	3-924-113-01	SPRING, DICT	
164	X-3302-412-0	ARM ASSY, FWD		186	3-927-422-01	BELT	
165	2-585-489-01	SPRING, TENSION		187	X-3370-772-1	ARM ASSY, DICT	
166	X-3302-424-3	TABLE ASSY, REEL, TAKE-UP		#3	7-627-850-07	SCREW, PRECISION +P 1.4X2	
167	3-701-436-01	WASHER, 1.6		#7	7-627-850-17	SCREW, PRECISION +P 1.4X2.5	
168	X-3302-414-3	TABLE ASSY, REEL, S		#8	7-624-101-04	STOP RING 1.2 (E TYPE)	
169	3-302-559-00	ROLLER, GUIDE, H PC BOARD		#9	7-627-850-47	SCREW, PRECISION +P 1.4X1.6	
170	3-570-552-00	SPRING, TENSION		#10	7-627-850-97	SCREW, PRECISION +P 1.4X2.2	
171	3-704-197-21	SCREW (1.4)		#11	7-671-111-11	BALL, STEEL 1.5mm	
172	3-306-186-01	SHAFT (PC BOARD GUIDE)		#12	7-671-155-01	BALL, STEEL 3mm	

5. ELECTRICAL PARTS LIST

NOTE:

- Due to standardization, replacements in the parts list may be different from the parts specified in the diagrams or the components used on the set.
- -XX and -X mean standardized parts, so they may have some difference from the original one.
- RESISTORS
All resistors are in ohms.
METAL: Metal-film resistor.
METAL OXIDE: Metal oxide-film resistor.
F: nonflammable

- Items marked “*” are not stocked since they are seldom required for routine service. Some delay should be anticipated when ordering these items.
- SEMICONDUCTORS
In each case, u : μ , for example:
uA.. : μ A.. uPA.. : μ PA..
uPB.. : μ PB.. uPC.. : μ PC.. uPD.. : μ PD..
- CAPACITORS
uF : μ F
- COILS
uH : μ H

When indicating parts by reference number, please include the board.

Ref. No.	Part No.	Description	Remark	Ref. No.	Part No.	Description	Remark
		DC-JACK BOARD *****		C124	1-162-970-11	CERAMIC CHIP 0.01uF 10%	25V
		< CAPACITOR >		C125	1-165-176-11	CERAMIC CHIP 0.047uF 10%	16V
C1	1-164-156-11	CERAMIC CHIP 0.1uF	25V	C126	1-164-156-11	CERAMIC CHIP 0.1uF	25V
		< JACK >		C127	1-162-966-11	CERAMIC CHIP 0.0022uF 10%	50V
J1	1-764-628-11	JACK, DC (POLARITY UNIFIED TYPE) (DC IN 3V)		C128	1-162-964-11	CERAMIC CHIP 0.001uF 10%	50V
*****				C129	1-104-847-11	TANTAL. CHIP 22uF 20%	4V
		LED BOARD *****		C130	1-162-927-11	CERAMIC CHIP 100PF 5%	50V
		< DIODE >		C131	1-126-513-11	ELECT 47uF 20%	6.3V
D5	8-719-047-19	LED GL8PR29 (DICT/BATT)		C132	1-104-912-11	TANTAL. CHIP 3.3uF 20%	16V
*****				C133	1-135-177-21	TANTAL. CHIP 1uF 10%	25V
	A-1119-343-A	MAIN BOARD, COMPLETE *****		C134	1-162-964-11	CERAMIC CHIP 0.001uF 10%	50V
		< CAPACITOR >		C135	1-162-964-11	CERAMIC CHIP 0.001uF 10%	50V
C101	1-165-176-11	CERAMIC CHIP 0.047uF 10%	16V	C136	1-164-730-11	CERAMIC CHIP 0.0012uF 10%	50V
C102	1-107-826-11	CERAMIC CHIP 0.1uF 10%	16V	C137	1-162-977-11	CERAMIC CHIP 0.0018uF 10%	50V
C103	1-110-569-21	TANTAL. CHIP 47uF 20%	6.3V	C138	1-135-201-11	TANTAL. CHIP 10uF 20%	4V
C104	1-164-156-11	CERAMIC CHIP 0.1uF	25V	C139	1-162-964-11	CERAMIC CHIP 0.001uF 10%	50V
C105	1-162-968-11	CERAMIC CHIP 0.0047uF 10%	50V	C140	1-162-970-11	CERAMIC CHIP 0.01uF 10%	25V
C106	1-165-176-11	CERAMIC CHIP 0.047uF 10%	16V	C141	1-164-346-11	CERAMIC CHIP 1uF	16V
C107	1-162-968-11	CERAMIC CHIP 0.0047uF 10%	50V	C142	1-164-346-11	CERAMIC CHIP 1uF	16V
C108	1-162-970-11	CERAMIC CHIP 0.01uF 10%	25V	C143	1-162-970-11	CERAMIC CHIP 0.01uF 10%	25V
C109	1-107-826-11	CERAMIC CHIP 0.1uF 10%	16V	C144	1-164-156-11	CERAMIC CHIP 0.1uF	25V
C110	1-164-156-11	CERAMIC CHIP 0.1uF	25V	C145	1-162-968-11	CERAMIC CHIP 0.0047uF 10%	50V
C111	1-126-781-11	ELECT 220uF 20%	4V	C146	1-104-847-11	TANTAL. CHIP 22uF 20%	4V
C112	1-164-677-11	CERAMIC CHIP 0.033uF 10%	16V	C147	1-110-569-21	TANTAL. CHIP 47uF 20%	6.3V
C113	1-162-964-11	CERAMIC CHIP 0.001uF 10%	50V	C148	1-164-730-11	CERAMIC CHIP 0.0012uF 10%	50V
C114	1-164-156-11	CERAMIC CHIP 0.1uF	25V	C149	1-162-967-11	CERAMIC CHIP 0.0033uF 10%	50V
C115	1-104-847-11	TANTAL. CHIP 22uF 20%	4V	C154	1-162-964-11	CERAMIC CHIP 0.001uF 10%	50V
C116	1-164-346-11	CERAMIC CHIP 1uF	16V	C155	1-164-677-11	CERAMIC CHIP 0.033uF 10%	16V
C117	1-164-156-11	CERAMIC CHIP 0.1uF	25V	C156	1-162-974-11	CERAMIC CHIP 0.01uF	50V
C118	1-162-964-11	CERAMIC CHIP 0.001uF 10%	50V	C157	1-110-569-21	TANTAL. CHIP 47uF 20%	6.3V
C119	1-104-700-11	CERAMIC CHIP 0.027uF 10%	16V	C158	1-135-201-11	TANTAL. CHIP 10uF 20%	4V
C120	1-162-967-11	CERAMIC CHIP 0.0033uF 10%	50V	C159	1-164-346-11	CERAMIC CHIP 1uF	16V
C121	1-164-346-11	CERAMIC CHIP 1uF	16V	C160	1-162-964-11	CERAMIC CHIP 0.001uF 10%	50V
C122	1-135-201-11	TANTAL. CHIP 10uF 20%	4V			< DIODE >	
C123	1-126-781-11	ELECT 220uF 20%	4V	D101	8-719-941-23	DIODE DA204UT106	
				D102	8-719-941-23	DIODE DA204UT106	
				D103	8-719-801-78	DIODE 1SS184	
				D104	8-719-801-78	DIODE 1SS184	
				D108	8-719-941-23	DIODE DA204UT106	
						< IC >	
				IC101	8-759-702-02	IC NJM062M	
				IC102	8-759-701-51	IC NJM2072M	
				IC103	8-759-345-42	IC NJM2606AM-TE2	

MAIN

Ref. No.	Part No.	Description	Remark	Ref. No.	Part No.	Description	Remark
IC104	8-759-701-51	IC NJM2072M		R115	1-216-825-11	METAL CHIP 2.2K 5%	1/10W
		< JACK >		R116	1-216-841-11	METAL CHIP 47K 5%	1/10W
J2	1-766-156-21	JACK (EAR)		R117	1-216-813-11	METAL CHIP 220 5%	1/10W
J3	1-766-156-21	JACK (MIC (PLUG IN POWER))		R118	1-216-821-11	METAL CHIP 1K 5%	1/10W
		< JUMPER RESISTOR >		R119	1-216-809-11	METAL CHIP 100 5%	1/10W
JP101	1-216-296-00	SHORT CHIP 0		R120	1-216-820-11	METAL CHIP 820 5%	1/10W
		< COIL >		R121	1-216-815-11	METAL CHIP 330 5%	1/10W
L101	not supplied			R122	1-216-812-11	METAL CHIP 180 5%	1/10W
L102	not supplied			R123	1-216-852-11	METAL CHIP 390K 5%	1/10W
		< PHOTO REFLECTOR >		R124	1-216-793-11	METAL CHIP 4.7 5%	1/10W
PH101	not supplied			R125	1-216-801-11	METAL CHIP 22 5%	1/10W
		< TRANSISTOR >		R126	1-216-833-11	METAL CHIP 10K 5%	1/10W
Q101	8-729-117-32	TRANSISTOR 2SC4177-T1L6		R127	1-216-833-11	METAL CHIP 10K 5%	1/10W
Q102	8-729-117-32	TRANSISTOR 2SC4177-T1L6		R128	1-218-867-11	METAL CHIP 6.8K 0.5%	1/10W
Q103	8-729-931-02	TRANSISTOR 2SC2413KQ		R129	1-216-833-11	METAL CHIP 10K 5%	1/10W
Q104	8-729-117-32	TRANSISTOR 2SC4177-T1L6		R130	1-216-835-11	METAL CHIP 15K 5%	1/10W
Q105	8-729-027-26	TRANSISTOR DTA114YKA-T146		R131	1-216-833-11	METAL CHIP 10K 5%	1/10W
Q106	8-729-931-02	TRANSISTOR 2SC2413KQ		R132	1-216-817-11	METAL CHIP 470 5%	1/10W
Q107	8-729-027-46	TRANSISTOR DTC114YKA-T146		R133	1-216-841-11	METAL CHIP 47K 5%	1/10W
Q108	8-729-027-46	TRANSISTOR DTC114YKA-T146		R134	1-216-820-11	METAL CHIP 820 5%	1/10W
Q109	8-729-800-71	TRANSISTOR 2SB815B7-TB		R135	1-216-805-11	METAL CHIP 47 5%	1/10W
Q110	8-729-117-32	TRANSISTOR 2SC4177-T1L6		R136	1-216-841-11	METAL CHIP 47K 5%	1/10W
Q111	8-729-027-26	TRANSISTOR DTA114YKA-T146		R137	not supplied		
Q112	8-729-800-71	TRANSISTOR 2SB815B7-TB		R138	1-216-822-11	METAL CHIP 1.2K 5%	1/10W
Q113	8-729-027-46	TRANSISTOR DTC114YKA-T146		R139	1-216-837-11	METAL CHIP 22K 5%	1/10W
Q114	8-729-901-47	TRANSISTOR DTA143EK		R140	not supplied		
Q115	8-729-027-46	TRANSISTOR DTC114YKA-T146		R141	1-218-271-11	METAL CHIP 2K 5%	1/10W
Q116	8-729-901-47	TRANSISTOR DTA143EK		R142	1-216-823-11	METAL CHIP 1.5K 5%	1/10W
Q117	8-729-117-32	TRANSISTOR 2SC4177-T1L6		R143	1-216-818-11	METAL CHIP 560 5%	1/10W
Q118	8-729-117-32	TRANSISTOR 2SC4177-T1L6		R144	1-216-853-11	METAL CHIP 470K 5%	1/10W
Q119	8-729-117-32	TRANSISTOR 2SC4177-T1L6		R145	1-216-852-11	METAL CHIP 390K 5%	1/10W
Q120	8-729-027-26	TRANSISTOR DTA114YKA-T146		R146	1-216-845-11	METAL CHIP 100K 5%	1/10W
Q121	8-729-027-26	TRANSISTOR DTA114YKA-T146		R147	1-216-833-11	METAL CHIP 10K 5%	1/10W
Q122	8-729-117-32	TRANSISTOR 2SC4177-T1L6		R148	1-216-841-11	METAL CHIP 47K 5%	1/10W
Q123	8-729-216-22	TRANSISTOR 2SA1162-G		R149	1-216-821-11	METAL CHIP 1K 5%	1/10W
Q124	8-729-117-32	TRANSISTOR 2SC4177-T1L6		R150	1-216-809-11	METAL CHIP 100 5%	1/10W
		< RESISTOR >		R151	1-216-843-11	METAL CHIP 68K 5%	1/10W
R101	1-216-820-11	METAL CHIP 820 5%	1/10W	R152	1-216-809-11	METAL CHIP 100 5%	1/10W
R102	1-216-829-11	METAL CHIP 4.7K 5%	1/10W	R153	1-216-829-11	METAL CHIP 4.7K 5%	1/10W
R103	1-216-835-11	METAL CHIP 15K 5%	1/10W	R154	1-216-857-11	METAL CHIP 1M 5%	1/10W
R104	1-216-828-11	METAL CHIP 3.9K 5%	1/10W	R155	1-216-817-11	METAL CHIP 470 5%	1/10W
R105	1-216-824-11	METAL CHIP 1.8K 5%	1/10W	R157	1-216-825-11	METAL CHIP 2.2K 5%	1/10W
R106	1-216-841-11	METAL CHIP 47K 5%	1/10W	R158	1-216-811-11	METAL CHIP 150 5%	1/10W
R107	1-216-841-11	METAL CHIP 47K 5%	1/10W	R159	1-216-811-11	METAL CHIP 150 5%	1/10W
R108	1-216-817-11	METAL CHIP 470 5%	1/10W	R160	1-216-835-11	METAL CHIP 15K 5%	1/10W
R109	1-216-826-11	METAL CHIP 2.7K 5%	1/10W	R163	1-216-853-11	METAL CHIP 470K 5%	1/10W
R110	1-216-827-11	METAL CHIP 3.3K 5%	1/10W	R172	1-216-813-11	METAL CHIP 220 5%	1/10W
R111	1-216-823-11	METAL CHIP 1.5K 5%	1/10W	R173	1-216-807-11	METAL CHIP 68 5%	1/10W
R112	1-216-823-11	METAL CHIP 1.5K 5%	1/10W	R174	1-216-837-11	METAL CHIP 22K 5%	1/10W
R113	1-216-841-11	METAL CHIP 47K 5%	1/10W	R175	1-216-814-11	METAL CHIP 270 5%	1/10W
R114	1-216-833-11	METAL CHIP 10K 5%	1/10W	R176	1-216-206-00	RES-CHIP 2.2K 5%	1/8W
				R177	1-216-845-11	METAL CHIP 100K 5%	1/10W
				R178	1-216-812-11	METAL CHIP 180 5%	1/10W
						< SWITCH >	
				S1	not supplied		
				S2	1-572-922-11	SWITCH, SLIDE (MIC SENS)	
				S3	1-571-277-51	SWITCH, SLIDE (TAPE SPEED)	

Ref. No.	Part No.	Description	Remark
S4	1-572-922-11	SWITCH, SLIDE (FAST PB)	
S5	1-572-922-11	SWITCH, SLIDE (VOR)	
S6	1-786-149-21	SWITCH, PUSH (1 KEY) (FF/CUE)	
S7	1-553-817-00	SWITCH, LEAF (POWER)	
* S9	1-786-079-21	SWITCH, PUSH (1 KEY) (B.SPACE)	
		< TRANSFORMER >	
T101	1-433-286-23	TRANSFORMER, BIAS OSCILLATION	
		< THERMISTOR (POSITIVE) >	
THP101	1-805-964-11	THERMISTOR, POSITIVE	
THP102	1-805-963-11	THERMISTOR, POSITIVE	
		< VARIABLE RESISTOR >	
VR101	1-223-749-12	RES, VAR, CARBON 10KX2 (VOL)	
VR102	not supplied		
VR103	not supplied		

MISCELLANEOUS			

105	1-548-516-00	TIMER, TAPE	
HD1	1-500-271-11	HEAD, MAGNETIC (REC/PB/ERASE)	
M1	X-3381-211-1	MOTOR ASSY	
MIC1	1-542-197-11	MICROPHONE, ELECTRET CONDENSER	
SP1	1-826-070-11	SPEAKER (2.8cm)	

ACCESSORIES			

	3-800-079-15	MANUAL, INSTRUCTION (ENGLISH,FRENCH)	(AEP)
	3-800-079-24	MANUAL, INSTRUCTION (ENGLISH) (US)	
	3-800-079-45	MANUAL, INSTRUCTION (GERMAN,DUTCH)	(AEP)
	3-927-765-01	INDIVIDUAL CARTON	

