

BM-77

SERVICE MANUAL

US Model
 Canadian Model
 AEP Model
 UK Model
 E Model





SPECIFICATIONS

Recording system	4-track 2-channel monaural (L channel for electronic index signals, R channel for sound signals)
Tape speed	4.8 cm/s (17/8 in./s), 2.4 cm/s (15/16 in./s)
Fast winding time	Approx. 2 min. 20 sec. with Sony cassette DC-90
Frequency response	200-5,000 Hz (at 2.4 cm/s) 200-8,000 Hz (at 4.8 cm/s)
Speaker	Approx. 5.7 cm (2 1/4 inches) dia.
Power output	350 mW (at 10% distortion)
Input	TELEPHONE PICKUP (minijack) Sensitivity 0.2 mV Input impedance 10 kohms
Output	EARPHONE (minijack) for 8-300-ohm earphones
CONTROL UNIT connector	for HU-80 or FS-75
Power requirements	9 V DC DC IN 9 V jack accepts the supplied AC power adaptor for use on 120 V AC, 60 Hz (US, Canadian model) 220 V AC, 50 Hz (AEP, E model) 240 V AC, 50 Hz (UK model)
Power consumption	14 W (US, Canadian model) (with the supplied AC power adaptor) 13 W (AEP, UK, E model) (with the supplied AC power adaptor)
Dimensions	Approx. 200 x 70 x 245 mm (w/h/d) (7 7/8 x 2 7/8 x 9 3/4 inches) including projecting parts and controls
Weight	Approx. 1.2 kg (2 lb 11 oz)
Supplied accessory	AC power adaptor (1)

Design and specifications subject to change without notice.

Model Name Using Similar Mechanism	BM-88
Tape Transport Mechanism Type	MB-88-59

SAFETY-RELATED COMPONENT WARNING!!

COMPONENTS IDENTIFIED BY MARK  OR DOTTED LINE WITH MARK  ON THE SCHEMATIC DIAGRAMS AND IN THE PARTS LIST ARE CRITICAL TO SAFE OPERATION. REPLACE THESE COMPONENTS WITH SONY PARTS WHOSE PART NUMBERS APPEAR AS SHOWN IN THIS MANUAL OR IN SUPPLEMENTS PUBLISHED BY SONY.

ATTENTION AU COMPOSANT AYANT RAPPORT À LA SÉCURITÉ!

LES COMPOSANTS IDENTIFIÉS PAR UNE MARQUE  SUR LES DIAGRAMMES SCHÉMATIQUES ET LA LISTE DES PIÈCES SONT CRITIQUES POUR LA SÉCURITÉ DE FONCTIONNEMENT. NE REMPLACER CES COMPOSANTS QUE PAR DES PIÈCES SONY DONT LES NUMÉROS SONT DONNÉS DANS CE MANUEL OU DANS LES SUPPLÉMENTS PUBLIÉS PAR SONY.



DICTATOR/TRANSCRIBER
SONY

TABLE OF CONTENTS

<u>Section</u>	<u>Title</u>	<u>Page</u>	<u>Section</u>	<u>Title</u>	<u>Page</u>
1. SERVICING NOTES			3. MECHANICAL ADJUSTMENTS		25
Notes for Repairing		3	4. ELECTRICAL ADJUSTMENTS		26
LCD Check Method		3	5. DIAGRAMS		
Microcomputer μ PD75308GF-496-3B9 (IC112)		4	5-1. Semiconductor Lead Layouts		27
			5-2. Printed Wiring Boards		28
			5-3. Schematic Diagram		33
2. GENERAL			6. EXPLODED VIEWS		
Features		10	6-1. Cabinet Section		37
How to Use This Manual		10	6-2. Mechanism Deck Section (1)		38
Precautions		10	6-3. Mechanism Deck Section (2)		39
Operation Flow Chart		11	7. ELECTRICAL PARTS LIST		40
Location and Function of Controls		12			
Preparation		14			
Dictation		15			
Transcription		19			
Erasing		21			
Alarm System		22			
Examples of Dictation and transcription		23			
Other Convenient Functions		24			

SAFETY CHECK-OUT

After correcting the original service problem, perform the following safety check before releasing the set to the customer:

Check the antenna terminals, metal trim, "metallized" knobs, screws, and all other exposed metal parts for AC leakage. Check leakage as described below.

LEAKAGE TEST

The AC leakage from any exposed metal part to earth ground and from all exposed metal parts to any exposed metal part having a return to chassis, must not exceed 0.5 mA (500 microamperes). Leakage current can be measured by any one of three methods.

1. A commercial leakage tester, such as the Simpson 229 or RCA WT-540A. Follow the manufacturers' instructions to use these instruments.
2. A battery-operated AC milliammeter. The Data Precision 245 digital multimeter is suitable for this job.
3. Measuring the voltage drop across a resistor by means of a VOM or battery-operated AC voltmeter. The "limit" indication is 0.75 V, so analog meters must have an accurate low-voltage scale. The Simpson 250 and Sanwa SH-63Trd are examples of a passive VOM that is suitable. Nearly all battery operated digital multimeters that have a 2V AC range are suitable. (See Fig. A)

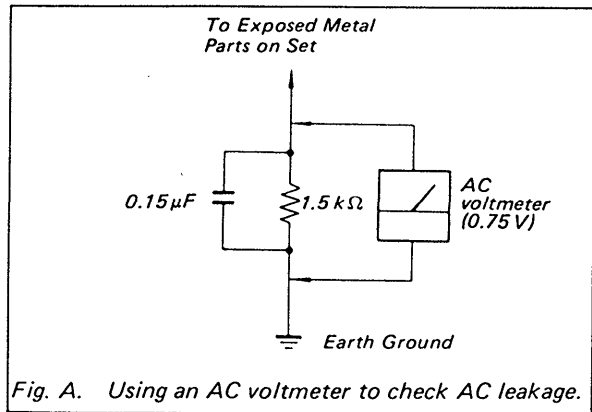

Fig. A. Using an AC voltmeter to check AC leakage.

SECTION 1 SERVICING NOTES

[NOTES FOR REPAIRING]

1. STANDBY ON (S101) Switch

The STANDBY ON switch is not a switch for turning ON/OFF the power source. Pay attention when repairing that the electricity is turned on even if the STANDBY ON switch is turned off.

- The states when turning off the STANDBY ON switch are as follows.

- a. LCD back light (EL901) will be turned off.
- b. LCD (ND901) display will be turned off.
- c. Motors (M901, 902) will be stopped.
- d. Plungers (PM901 to 903) will be turned off.

The above items from b to d are controlled by the microcomputer which makes the pin ③ of IC112 (microcomputer) become Low level.

2. IC Link (PS101)

Attention should be paid when repairing because the IC link is cut if the circuit is shortened by mistake.

3. Crack of Flywheel Gear and Cam Gear

Do not turn the flywheel counterclockwise.

The flywheel gear and cam gear may be crack when turn the flywheel counterclockwise.

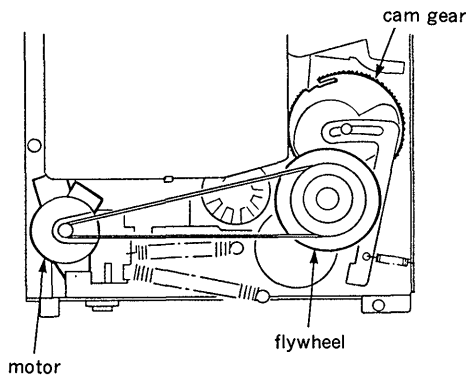

[LCD CHECK METHOD]

This unit has LCD all lighting mode to check LCD.

1. In order to perform LCD all lighting,

- Without inserting a cassette, press the three buttons of RESET, ERASE, SCAN at the same time.
LCD is all lighting.





2. In order to release LCD all lighting,

- Insert a cassette, or turn off the STANDBY ON switch once.

[MICROCOMPUTER μ PD75308GF-496-3B9 (IC112)]

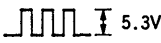
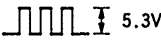
1. Terminal Description

Pin No.	Pin Name	Usage	Voltage, Remarks												
1	S12	LCD segment output													
2	S13	LCD segment output													
3	S14	LCD segment output													
4	S15	LCD segment output													
5	S16	LCD segment output													
6	S17	LCD segment output													
7	S18	LCD segment output													
8	S19	LCD segment output													
9	S20	LCD segment output													
10	S21	LCD segment output													
11	S22	LCD segment output													
12	S23	LCD segment output													
13	KOUT 0	Key scan output													
14	KOUT 1	Key scan output													
15	KOUT 2	Key scan output													
16	KOUT 3	Key scan output													
17	MA50-OUT	Amplifier gain control output at MA-50 (micro cassette adaptor)	When using MA-50 : 5.3V When using the other : 0.1V												
18	—	Not used	Open												
19	4.8/2.4-OUT	Tape speed control output	At LISTEN of 4.8cm/s : 5.3V At the other : 0.2V												
20	—	Not used	Open												
21	COM 0	LCD common output													
22	COM 1	LCD common output													
23	COM 2	LCD common output													
24	—	Not used	Open												
25	LCD-BIAS	Output for LCD outer resistance	5.3V												
26	V _{LCD0}	Power source for LCD drive	2.4V												
27	V _{LCD1}	Power source for LCD drive	1.6V												
28	V _{LCD2}	Power source for LCD drive	0.8V												
29	FE-OUT	Fast-Erase control output	At Fast-Erase : 0V At the other : 5.9V												
30	BIAS-OUT	BIAS control output	At DICT, TEL-REC : 0V At the other : 5.9V												
31	BRK-PG-OUT	Brake plunger output	Normal : 6.0V STOP from FF/REW : 												
32	STOP-PG-OUT	Stop plunger output	Normal : 0V STOP from FWD : 												
33	VSS	GND	0V												
34	FWD-PG-OUT	FWD plunger output	At FWD : 5.9V At the other : 0V												
35	FF-M-OUT	} FF/REW motor output	<table border="1"> <tr> <td></td> <td>At motor FF</td> <td>At motor REW</td> <td>At the other</td> </tr> <tr> <td>Pin ⑤</td> <td>0V</td> <td>5.9V</td> <td>5.9V</td> </tr> <tr> <td>Pin ⑥</td> <td>5.9V</td> <td>0V</td> <td>5.9V</td> </tr> </table>		At motor FF	At motor REW	At the other	Pin ⑤	0V	5.9V	5.9V	Pin ⑥	5.9V	0V	5.9V
	At motor FF			At motor REW	At the other										
Pin ⑤	0V	5.9V	5.9V												
Pin ⑥	5.9V	0V	5.9V												
36	REW-M-OUT														
37	A-OFF-OUT	Motor Auto-off output	Motor Auto-off (no cassette or after three minutes after STOP) : 1.9V At the other : 0V												
38	STAND-BY	Standby switch input	ON : 5.3V STAND-BY : 0V												

Pin No.	Pin Name	Usage	Voltage, Remarks									
39	TAB-IN	TAB (erase proof) detection switch input	Cassette with TAB : 0V, cassette without TAB : 5.3V									
40	MC-IN	MA-50 (micro cassette adaptor) or cassette half detection switch input	Cassette or with MA-50 : 0V, without a cassette and without MA-50 : 5.3V									
41	CAS-IN	Cassette detection switch input	With a cassette : 0V, without a cassette : 5.3V									
42	SR	S reel signal input										
43	TR	T reel signal input										
44	DICT-IN	HU-DICT key input	At DICT key input of the hand control unit (HU-80) : 0V At the other : 5.3V									
45	LTR-DET	LTR/SEC signal input	Count the rectangular pulse with the microcomputer <table border="1"> <thead> <tr> <th></th> <th>LTR</th> <th>SEC</th> </tr> </thead> <tbody> <tr> <td>At LISTEN</td> <td>60 to 160Hz</td> <td>800 to 2000Hz</td> </tr> <tr> <td>At FF/REW</td> <td>600 to 4800Hz</td> <td>8kHz to 60kHz</td> </tr> </tbody> </table>		LTR	SEC	At LISTEN	60 to 160Hz	800 to 2000Hz	At FF/REW	600 to 4800Hz	8kHz to 60kHz
	LTR	SEC										
At LISTEN	60 to 160Hz	800 to 2000Hz										
At FF/REW	600 to 4800Hz	8kHz to 60kHz										
46	LTR-OUT	LTR/SEC signal output	At LTR oscillating :  5.3V Output 80Hz for three seconds. At SEC oscillating :  5.3V Output 1kHz for three seconds. At the other : 5.3V									
47	REC-OUT	DICT, TEL-REC control output	At DICT, TEL-REC : 5.0V At the other : 0V									
48	TEL-OUT	TEL-REC control output	At TEL-REC : 5.3V At the other : 0V									
49	ALM-OUT	Alarm output	At alarm oscillating :  5.3V 2.05kHz									
50	KIN 0	key scan input										
51	KIN 1	key scan input										
52	KIN 2	key scan input										
53	KIN 3	key scan input										
54	VDD	Positive power source terminal of the microcomputer	5.3V									
55	—	Not used	Connect to VSS									
56	—	Not used	Open									
57	NC	Not used	Connect to VDD									
58	X 1	Input for clock oscillation	 5V _{p-p} 4.19MHz									
59	X 2	Input for clock oscillation	 5.5V _{p-p} 4.19MHz									
60	HU-LIS-IN	HU-LISTEN key input	At LISTEN key-in of the hand control unit (HU-80) : 0.8V At the other : 5.3V									
61	BS-IN	HU-BS key input	At BS key in of the hand control unit (HU-80) : 0.8V At the other : 5.3V									
62	PB-OUT	Playback control output	At LISTEN : 5.3V At the other : 0V									
63	MUTE-OUT	Amplifier mute output	At LISTEN, DICT, TEL-REC : 5.3V At the other : 0V									
64	FS-IN	HU-FS key input	At FS key input of the hand control unit (HU-80) : 0.1V At the other : 5.3V									
65	PR-IN	Foot switch LISTEN key input	At LISTEN key input of the foot control unit (FS-75) : 0.1V At the other : 5.3V									
66	SEC-IN	HU-SEC key input	At SEC key input of the hand control unit (HU-80) : 0.1V At the other : 5.3V									

Pin No.	Pin Name	Usage	Voltage, Remarks
67	LTR-IN	HU-LTR key input	At LTR key input of the hand control unit (HU-80) : 0.1V At the other : 5.3V
68	RESET	Microcomputer•reset input	Normal : 5.3V
69	S 0	LCD segment output	
70	S 1	LCD segment output	
71	S 2	LCD segment output	
72	S 3	LCD segment output	
73	S 4	LCD segment output	
74	S 5	LCD segment output	
75	S 6	LCD segment output	
76	S 7	LCD segment output	
77	S 8	LCD segment output	
78	S 9	LCD segment output	
79	S 10	LCD segment output	
80	S 11	LCD segment output	

2. LCD (ND901) Connection Diagram

* : The name of S12 is all the same because S12 is shortened on the printed board.

SEGMENT

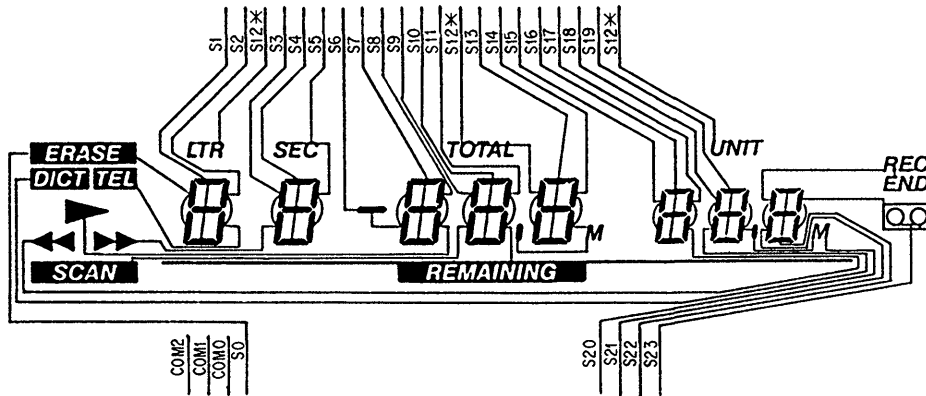

COMMON

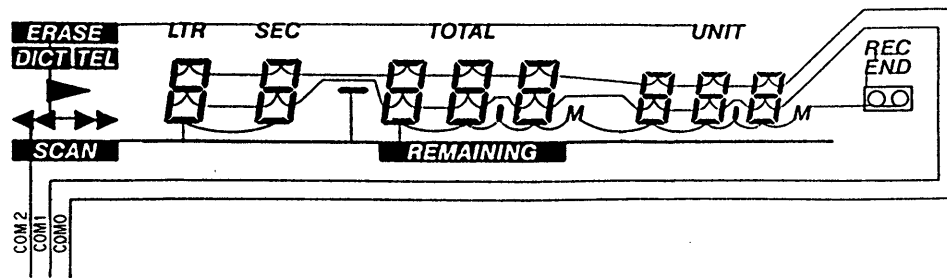

● LCD Check Method

This unit has LCD all lighting mode in order to check LCD.

1. In order to perform LCD all lighting,
 - Without inserting a cassette, press the three buttons of RESET, ERASE, SCAN at the same time.
LCD is all lighting.
2. In order to release LCD all lighting,
 - Insert a cassette, or turn off the STANDBY ON switch once.

3. LCD Display Map

* Segment output (S0 to 23)

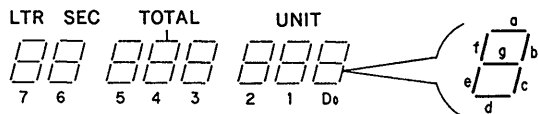

IC112 Pin No.	Segment Name	COM 0	COM 1	COM 2
12	S23	Counter D0-b	Counter D0-c	
11	S22	Counter D0-a	Counter D0-g	Counter D0-d
10	S21	Counter D0-f	Counter D0-e	"REC END"
9	S20	Counter D1-b	Counter D1-c	". ." (dot) and "M"
8	S19	Counter D1-a	Counter D1-g	Counter D1-d
7	S18	Counter D1-f	Counter D1-e	"DICT"
6	S17	Counter D2-b	Counter D2-c	◀ (REW)
5	S16	Counter D2-a	Counter D2-g	Counter D2-d
4	S15	Counter D2-f	Counter D2-e	(not used)
3	S14	Counter D3-b	Counter D3-c	". ." (dot) of TOTAL and "M"
2	S13	Counter D3-a	Counter D3-g	Counter D3-d
1	S12	Counter D3-f	Counter D3-e	"TOTAL", "UNIT", "LTR" (short on the LCD block board)
80	S11	Counter D4-b	Counter D4-c	"REMAINING"
79	S10	Counter D4-a	Counter D4-g	Counter D4-d
78	S9	Counter D4-f	Counter D4-e	"SCAN"
77	S8	Counter D5-b	Counter D5-c	▶ (FWD)
76	S7	Counter D5-a	Counter D5-g	Counter D5-d
75	S6	Counter D5-f	Counter D5-e	■ (minus sign)
74	S5	Counter D6-b	Counter D6-c	"SEC"
73	S4	Counter D6-a	Counter D6-g	Counter D6-d
72	S3	Counter D6-f	Counter D6-e	▶▶ (FF)
71	S2	Counter D7-b	Counter D7-c	"TEL"
70	S1	Counter D7-a	Counter D7-g	Counter D7-d
69	S0	Counter D7-f	Counter D7-e	"ERASE"

- The pin name of the microcomputer (IC112) and the LCD segment name are the same.

4. Key•Scan•Matrix

The pin No. and the pin name stand for those of the microcomputer (IC112).

Output		(Pin No.) 13	14	15	16
		(Pin Name) KOUT 0	KOUT 1	KOUT 2	KOUT 3
(Pin No.)	(Pin Name)	RESET (S110)	ERASE (S109)	TEL REC (S108)	SCAN (S107)
50	KIN 0				
51	KIN 1	FF (S114)	REW (S113)	LISTEN (S112)	STOP (S111)
52	KIN 2	REVERSE TIME			
		(Pin ① of S106)	(Pin ② of S106)	(Pin ③ of S106)	(Pin ④ of S106)
53	KIN 3	not used	not used	AUTO STOP (S104)	TAPE SPEED (S102)

- Hard is controlled by Low active (Low is input with turning on each switch.)

TAPE SPEED is 4.8cm/s at Low.

AUTO STOP is turned "ON" at Low.

Refer to the following figure for the key matrix of S106.

S106 position ○: ON

	0	1	2	3	4	5	6	7	8	9
Between C and 1		○		○		○		○		○
Between C and 2			○	○			○	○		
Between C and 3					○	○	○	○		
Between C and 2									○	○

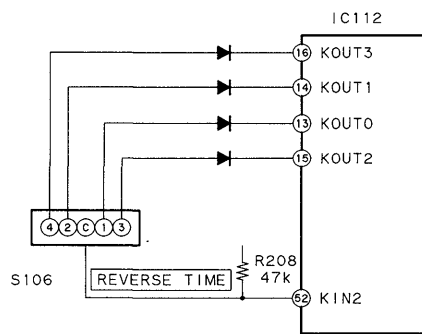

- Key•scan is controlled by Low active.

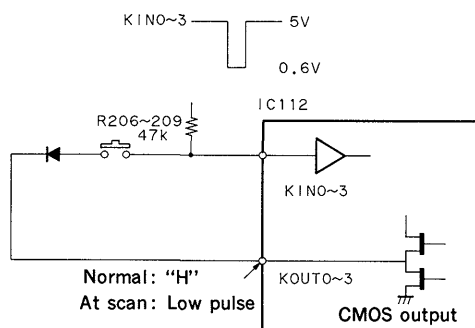

5. Detection of T and S Reel

Pin ④ of IC112: T reel }
 Pin ⑤ of IC112: S reel }

Waveform condition:

- Tape C-90 is used.
- The period is different by the tape position.

FWD:

T reel at the tape TOP }
 S reel at the tape END }

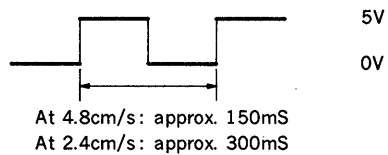

S reel at the tape TOP }
 T reel at the tape END }

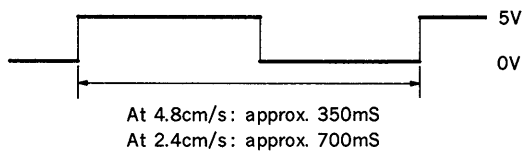

FF/REW:

T reel at the tape TOP }
 S reel at the tape END }

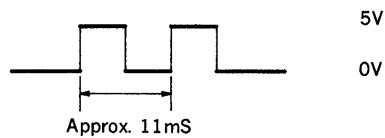

S reel at the tape TOP }
 T reel at the tape END }

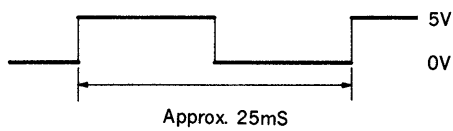

* The speed of FF and REW is the same when the tape speed switch is 4.8cm/s or 2.4cm/s.

Features

The Sony BM-88 dictator/transcriber is designed to be used for both dictation and transcription.
The Sony BM-77 transcriber is designed to be used only for transcription.

As a dictator (BM-88 only)

- The Sony HU-80 hand control unit (optional) remotely controls the BM-88 dictator/transcriber.
- Dual electronic indexing function signals—"LTR" (end of letter) and "SEC" (special instructions to secretary) signals—can be recorded on a tape during dictating, recording of telephone calls, listening or in the stop mode.
- The end of the last recorded segment on the tape can easily be located using the record-end function.
- Alarm sound and indication on the display window informs recording error.
- Recording of telephone calls can be performed with the use of the optional TL-2 message coupler.
- With the use of the optional DE-35, DE-36 or MDR-U10M earphones, you can monitor the sound with the desired sound level during recording.

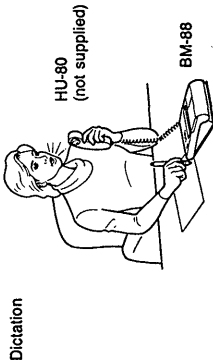

Dictation

As a transcriber

- The scanning function allows easy display of the total recorded time of dictation in minutes, the number of documents and instructions recorded on the tape.
- Auto-stop function quickly accesses instructions and documents.
- VSC (Variable Speech Control) enables rapid and easy-to-listen-to playback. (BM-88)
- Auto backspace function with the REVERSE TIME control makes transcribing easy by enabling the reviewing of the last recorded words each time listening is resumed.
- Two tape speeds (4.8 cm/sec. and 2.4 cm/sec.) can be selected according to the user's needs.
- Rapid erasing function with ERASE and REW buttons.
- Microcassette transcription is possible with the use of the optional MA-50 microcassette adaptor.

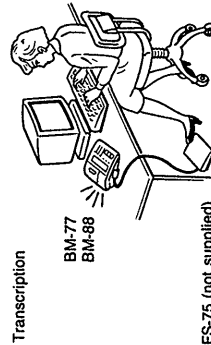

Transcription

FS-75 (not supplied)

How to Use This Manual

This instruction manual covers two models, BM-77 and BM-88. The differences in the models will be clearly described in this manual. If you have the model BM-77, please skip pages 15 to 16, 18 to 19 and page 23.

Most of the illustrations used in this manual are those of the BM-88.

Precautions

- Operate the unit only on 9 V DC.
- For AC operation, use the AC power adaptor supplied with this unit. Do not use any other AC power adaptor as it may cause malfunction.
- Unplug the AC power adaptor from the wall outlet when it will not be used for an extended period of time. To disconnect the adaptor, pull it out by grasping the adaptor. Never pull it by the cord.
- Do not install the unit in a location near heat sources such as radiators or airducts, or in a place subject to direct sunlight, excessive dust, mechanical vibration, or shock.
- Allow adequate air circulation to prevent internal heat build-up. Do not place the unit near materials (curtains, draperies) that may block the ventilation holes.
- Should any solid object or liquid fall into the unit, unplug the unit and have it checked by qualified personnel before operating it any further.
- The AC power adaptor which has been supplied becomes hot if it is connected to an AC outlet for a long period of time. But, this will not cause any trouble.

If you have any question or problem concerning your unit that is not covered in this manual, please consult the Sony dealer from whom you purchased the unit.

SECTION 2 GENERAL

This section is extracted from instruction manual.

Operation Flow Chart

For details, refer to the pages in ●.
 □ : Necessary step □ : Optional step

Dictation (BM-88 only)

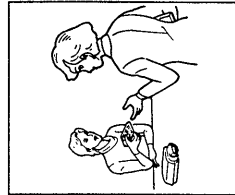
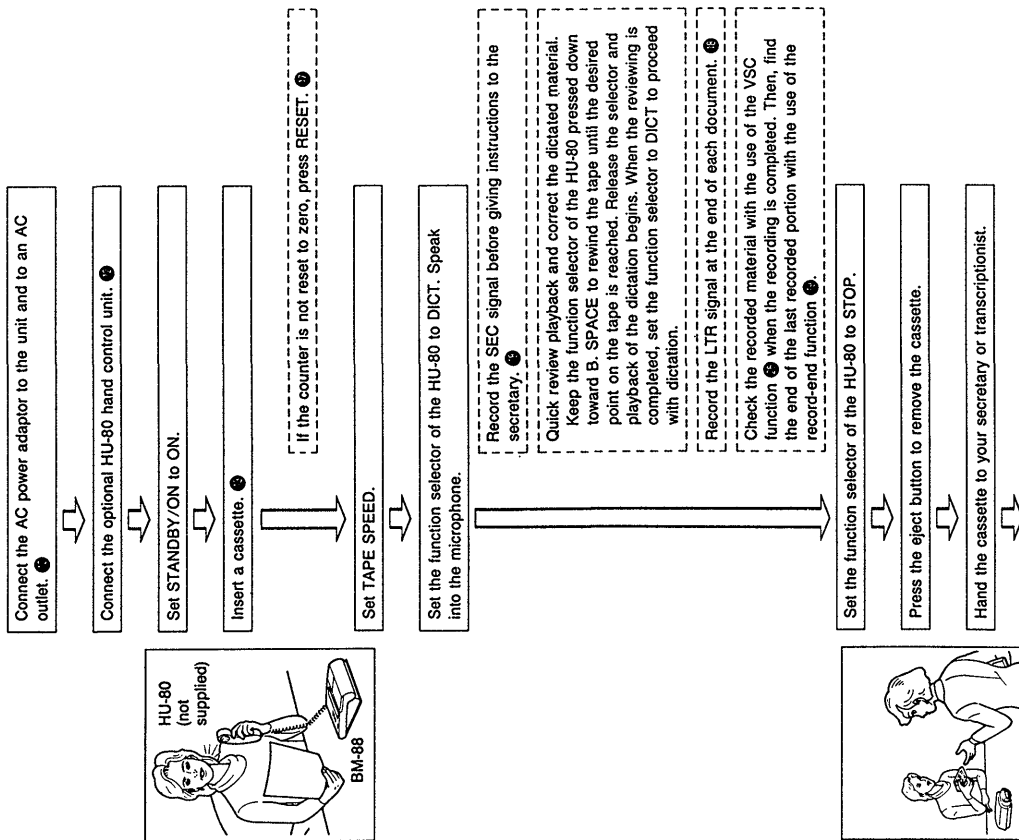

Transcription (BM-77/BM-88)

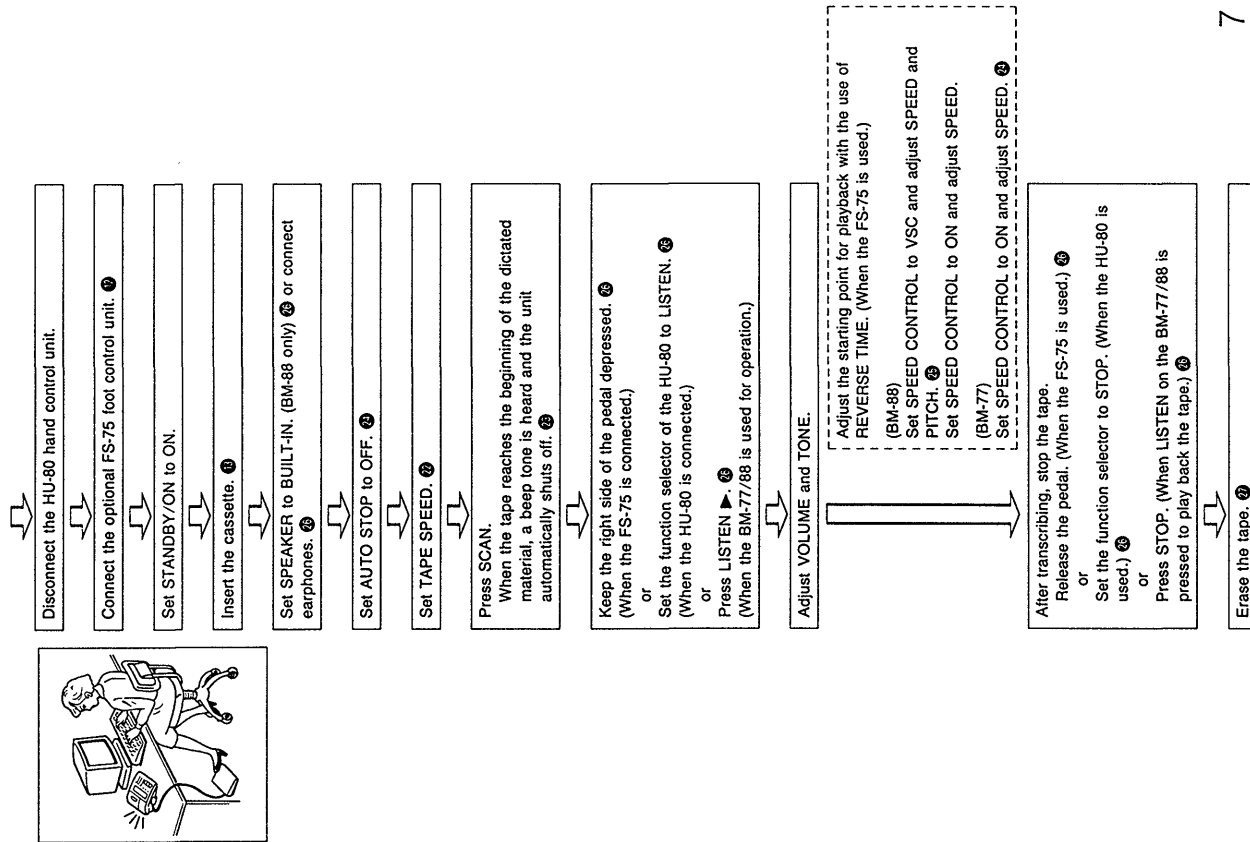

Location and Function of Controls

For details, refer to the pages indicated in ●.

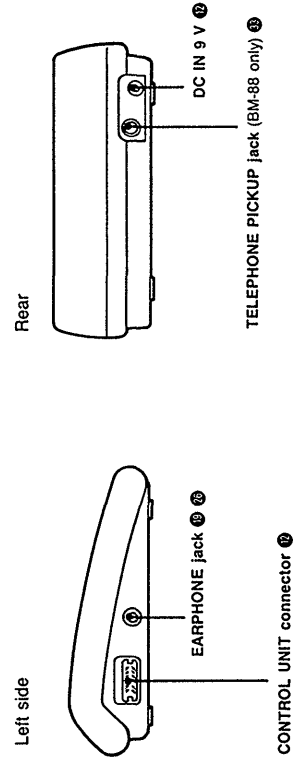
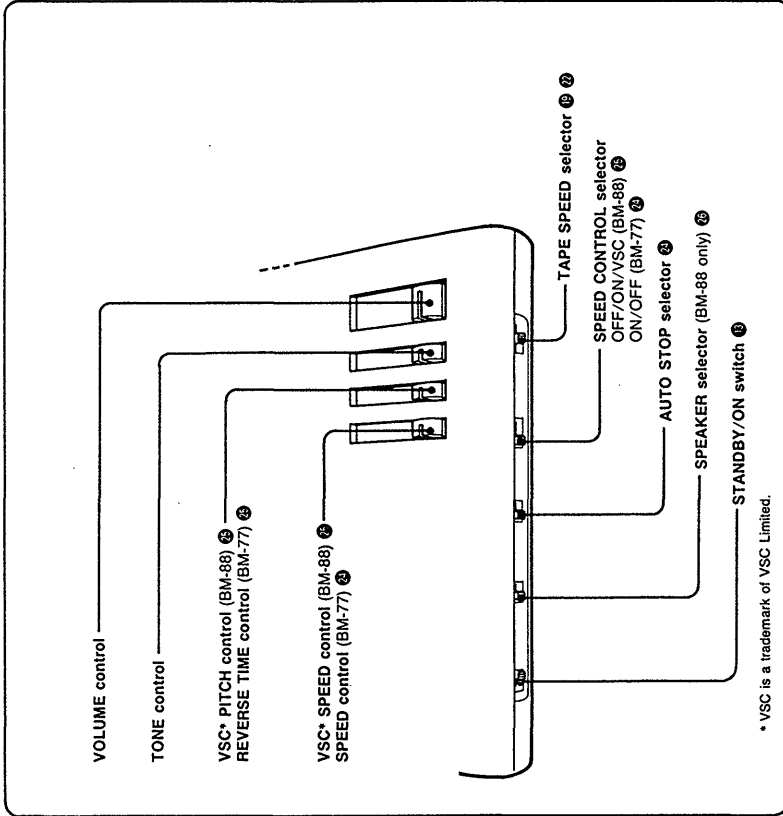
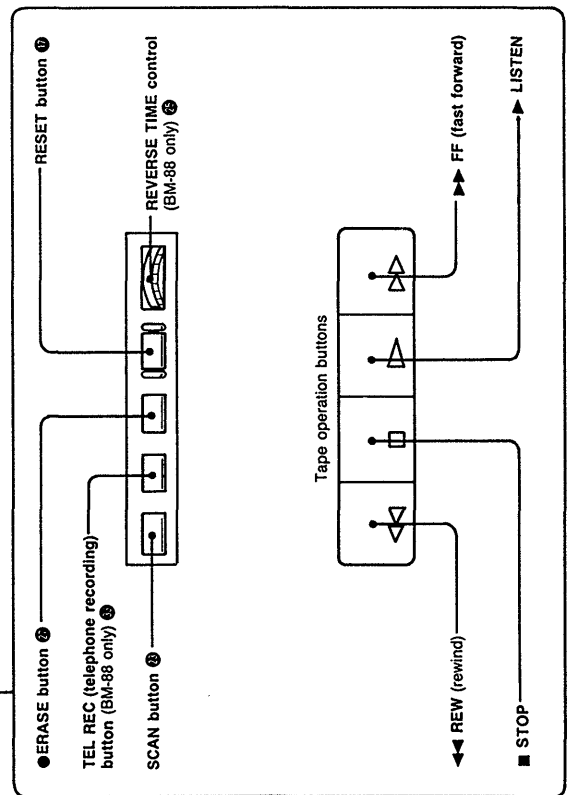
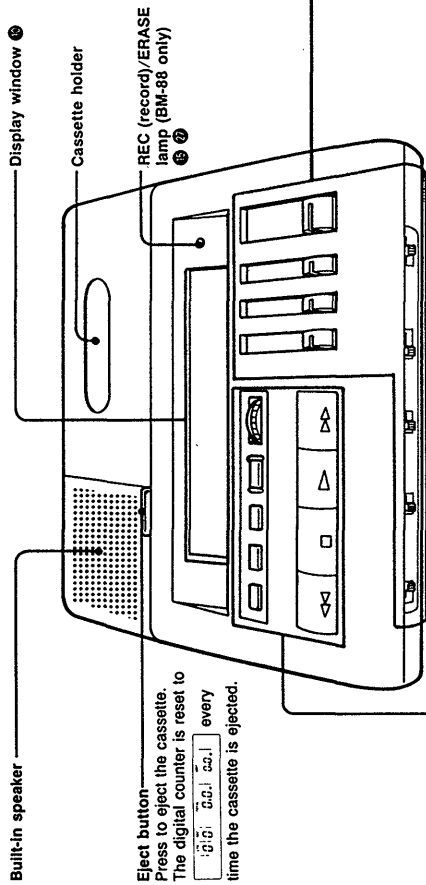

Location and Function of Controls

Display window

SEC (secretary) Special instructions for secretary counter Displays the number of special-instructions-for-secretary signals recorded.

LTR (letter) End of letter counter Displays the number of end-of-letter signals (i.e. the number of documents) recorded.

TEL (telephone) recording indicator Displayed during recording of telephone calls.

ERASE indicator Displayed while the cassette is being erased.

DICT (dictation) indicator Displayed during recording.

(listen) indicator Displayed during playback.

(rewind) indicator Displayed while the cassette is being rewound.

SCAN indicator Appears when the SCAN button is pressed

REMAINING indicator While SCAN is displayed, REMAINING is also displayed. In this case, the display window indicates the remaining time of the recorded documents, remaining numbers of recorded LTR and SEC signals and the remaining time of the actual document. This disappears with a long beep tone when the tape reaches the tape top.

(fast forward) indicator Displayed while the tape is advanced rapidly.

TOTAL (time/tape) counter Displays time or tape length of the recorded documents. The time counter and the tape counter is switched by pressing the RESET button for more than two seconds.

Time counter Indicates the approximate time of the recorded documents.

Tape counter Indicates the tape length of the recorded documents.

UNIT (time) counter Displays the time of each recorded document, i.e. displays the approximate recorded time of a citation, from the portion where the LTR signal is recorded to the portion where the next LTR signal is recorded.

REC END indicator Blinks for approx. three seconds when the recording end portion is detected and disappears.

(cassette) indicator Displayed while cassette is inserted. The indicator blinks in the following cases:

- The button is pressed when no cassette is inserted or when the cassette's safety tabs have been removed.
- About 3 minutes before reaching the end of the tape.
- End of tape or the tape is torn.

REMAINING indicator Appears when the SCAN button is pressed. While REMAINING is displayed, recordings of dictation, telephone calls, LTR signals and SEC signals cannot be made.

If the function selector is set to DICT or TEL REC (BM-88 only), LTR or SEC button is pressed, REMAINING blinks and a beep tone is heard.

The numbers on the digital counter (LTR, SEC, TOTAL and UNIT) indicate the remaining number of the LTR signals and the SEC signals, remaining amount of dictations (TOTAL) and remaining time of the actual document while the unit is in playback, fast forward or rewind mode.

To clear the REMAINING mark, press RESET or the eject button.

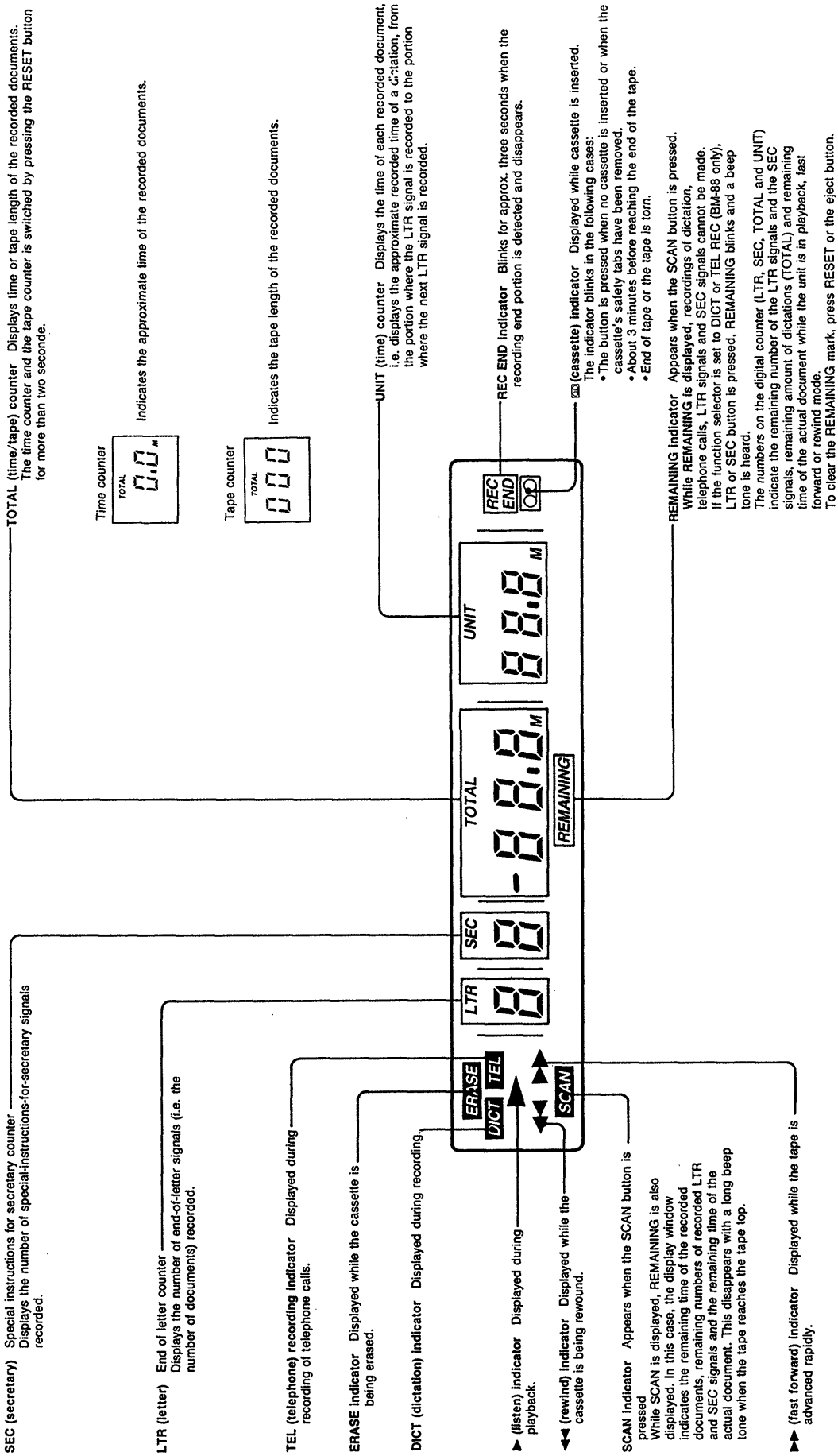

Notes

- It may be difficult to read the liquid crystal counter display due to the watching angle.
- The counter reading may work incorrectly if a music cassette or a monaural recorded cassette is played back.

Preparation

Power Connection

Note on the AC power adaptor

Use only the AC power adaptor supplied. Do not use any other AC power adaptor.

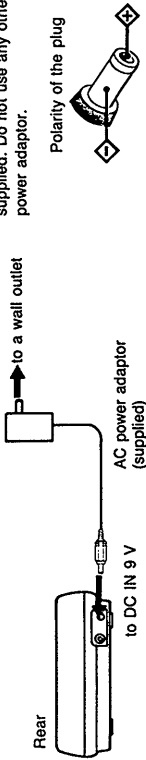

Connecting the HU-80 Hand Control Unit (not supplied) (BM-88 only)

For operation, refer to "Dictation" on page 6.

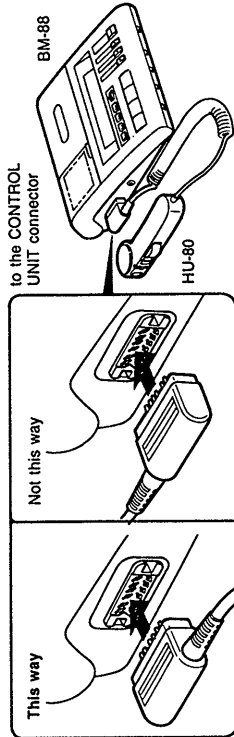

Attaching the cradle
Attach the supplied cradle with the HU-80 to the left or right side of the unit. Place the HU-80 hand control unit on the cradle while not in use. Insert the cradle into the slots and slide to secure it.

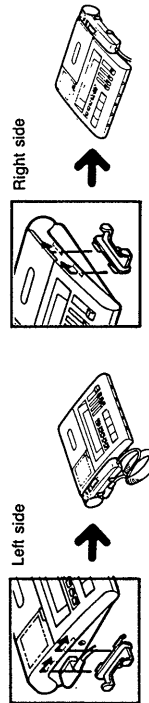

Connecting the FS-75 Foot Control Unit (not supplied)

For operation, refer to "Transcription" on page 8.

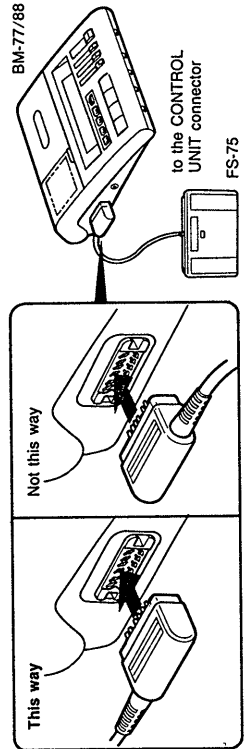

Cassette Insertion

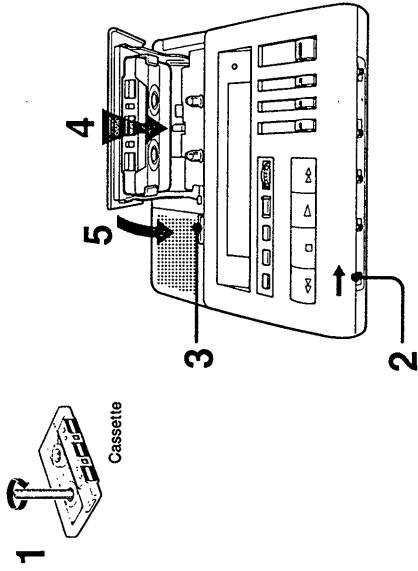

- 1 Take up any slack in the tape.
- 2 Set STANDBY/ON to ON.
- 3 Press the eject button to open the cassette holder.
- 4 Insert a cassette into the cassette holder with the side to be recorded on or played back facing upward.
- 5 Close the cassette holder.
The digital counter displays zero and 00 appears.

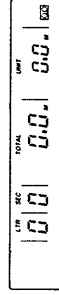

Preparation

- **Notes on cassettes**
 - Any standard cassette can be used, but the optional Sony leaderless cassette DC-60 or DC-90 is recommended. The use of the chromium dioxide or metal type of cassette is not advisable.
 - Choose a cassette of suitable length. Recording time of each side of these cassettes (at 4.8 cm/s) is as follows:
 - DC-60 Approx. 30 minutes
 - DC-90 Approx. 45 minutes
 - We do not recommend the use of cassettes with a running time of longer than 90 minutes.
 - The letter A on the Sony cassette is embossed to help you distinguish that side of the cassette in a dimly lit area.

To prevent accidental erasure
 When the BM-88 is operated in record mode, previous recordings are automatically erased. For this reason, cassettes incorporate a safety device to prevent accidental erasure. When the small tabs at the rear of a cassette are broken out, an interlock on the BM-88 will be activated, preventing recording. To protect side A recording, break out the tab of that side. For the protection of side B, break out the tab of that side. When the cassette is installed for telephone recording with the tabs broken out, the TEL REC button does not operate. When the cassette is installed for dictating with the tabs broken out, recording cannot be attempted, but the alarm sound is heard.

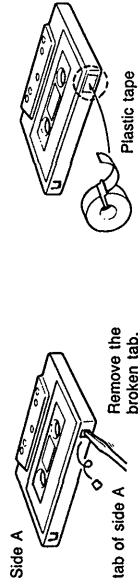

To reuse a cassette for recording after the tabs have been removed, simply cover each slot with a small piece of plastic tape. Do not stick any material on any part of the cassette except the circled portions, as shown.

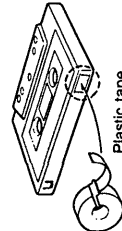

Dictation (BM-88 only)

To use the unit as a dictating machine, connect the HU-80 hand control unit (not supplied). For connection, see page 16.

Operation

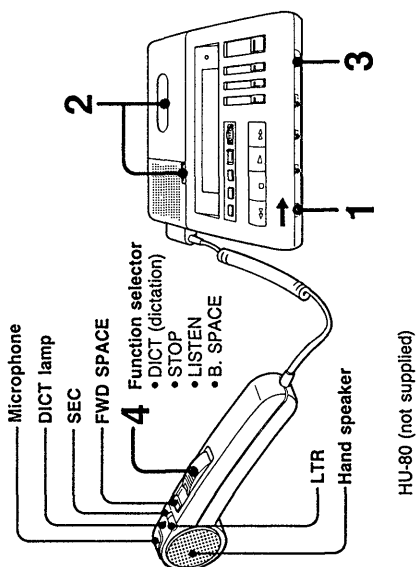

HU-80 (not supplied)

- 1 Set STANDBY/ON to ON.
- 2 Insert a cassette. (See page 16.)
- 3 Set TAPE SPEED to the desired tape speed, 4.8 or 2.4 (cm/sec.).
- 4 Set the function selector to DICT. Recording starts. Speak into the microphone. DICT appears on the display window. The DICT lamp on the hand control unit lights up and REC/ERASE lamp on the BM-88 blinks when the microphone picks up sound.

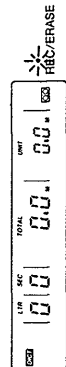

To stop the tape
 Set the function selector to STOP.

Note
 Keep the HU-80 away from the BM-88 during recording. If not, noise may be recorded.

Dictation (BM-88 only)

Digital Counter

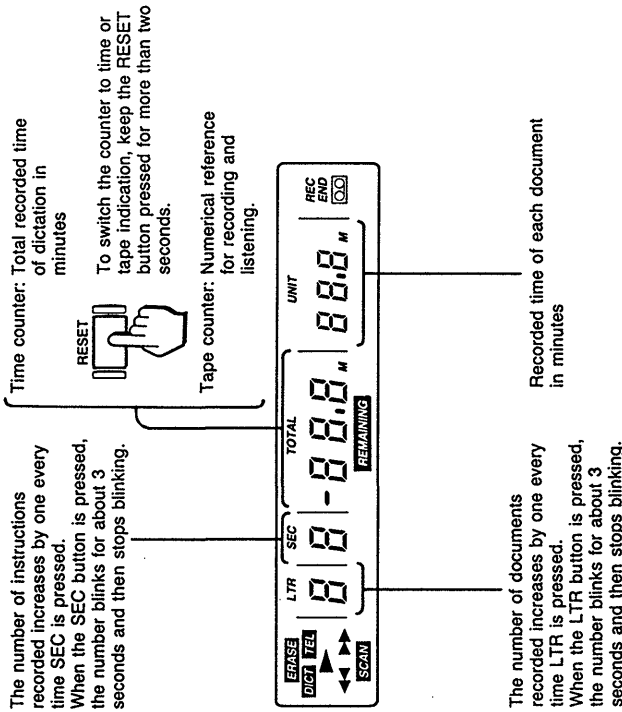

To set the digital counter to zero

We recommend that you press the RESET button before starting dictation. Keep the RESET button pressed for more than 0.5 second to reset the LTR (document), SEC (special instruction), TOTAL (time/tape) and UNIT (time) counters to zero.

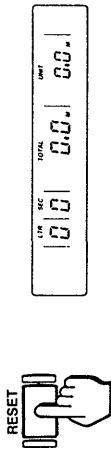

To reset the TOTAL (time/tape) counter to zero tape counter

When the RESET button is pressed for more than 2 seconds in the tape stop mode, the TOTAL (time/tape) counter changes to 000 and functions as a tape counter.

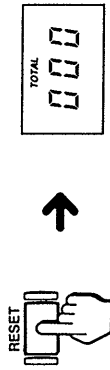

To reset the TOTAL (time/tape) counter to zero time counter

Keep the RESET button pressed for more than 2 seconds.

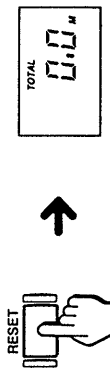

The TOTAL (time/tape) counter and the UNIT time counter indicate the approximate time of the recorded material.

Notes

- The time counters are normally within plus or minus two minutes of the actual time when using a DC-90 cassette.
- In case a cassette other than DC-60 and DC-90 is used, the time counter reading may differ to a larger extent from the actual time.
- The tape counter is switched to the time counter when the SCAN button is pressed.
- The numbers on the digital counter are memorized even when the STANDBY/ON switch is turned off.

Dictation (BM-88 only)

Convenient Functions

■ To record LTR (letter) and SEC (secretary) signals

You can record electronic index signals on the tape while the unit is set in recording (dictation), telephone recording, stop or playback (with the HU-80) mode.

LTR (letter=end of document) signal: Record at the end of each document.
 SEC (secretary = special instructions to secretary) signal: Record before giving instructions to the secretary.

When the AUTO STOP function (page 25) is activated (AUTO STOP: ON), the tape automatically stops at each index signal when it is rewound, rapidly advanced or scanned. Documents and instructions can be located without the user's having to listen to the entire tape.

Before dictating, press RESET to reset the counters to zero.

To record the LTR signal

Press LTR on the HU-80.
 Each time the button is pressed, the number on the LTR (document) counter increases by one.

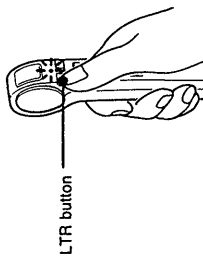

LTR button

To record the SEC signal

Press SEC on the HU-80.
 Each time the button is pressed, the number on the SEC (special instruction) counter increases by one.

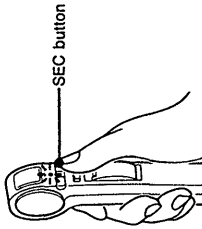

SEC button

When the LTR or SEC signal is recorded, the number on the counter blinks and then lights up. Up to nine signals each can be recorded on each side of a cassette. If more than nine signals are recorded, "E" appears in the counter display.

Notes

- The LTR or the SEC signal should be recorded with the intervals of more than 6 seconds.
- If the LTR or the SEC button is pressed while winding the tape rapidly (FF or REW), an alarm may sound continuously. In this case, stop the tape motion and wind the tape rapidly again.
- Playback sound is muted when either the LTR or SEC button is pressed.
- If either the LTR or SEC button is pressed while turning on the SPEED CONTROL selector, the tape will run at normal tape speed.
- While playing back, if either the LTR or SEC button is pressed to record the index signal on the previously recorded LTR or SEC signal by mistake, a beep tone is heard and the index signal cannot be recorded.

■ Record-end function

You can easily find the end of the last recorded segment on the tape. This function enables you to continue recording from the point where you left off.

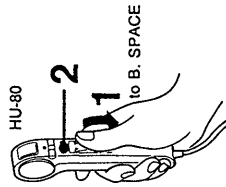

HU-80

2

1

to B. SPACE

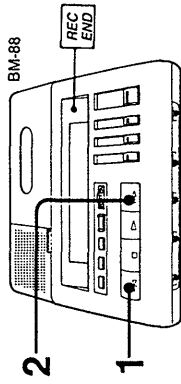

BM-88

2

1

REC END

- 1 Rewind the tape a little.
- 2 Press **▶▶** FF (FWD SPACE).

The tape will rapidly advance and stop at the end of the last recorded segment. At the end of the last recording, a long beep tone is heard and REC END blinks for approx. 3 seconds on the display window and then, disappears.

If the unit is set in record mode by mistake, immediately stop the recording. The record-end function does not operate if the recorded material is shorter than a second.

• Once the cassette is ejected or the STANDBY/ON switch is set to STANDBY, the record-end memory is cleared and the record-end function does not operate.

Recording time

Possible recording times of each side of cassettes are as follows.

Cassette	TAPE SPEED selector	
	4.8	2.4
Sony DC-60	30 minutes	60 minutes
Sony DC-90	45 minutes	90 minutes

■ Monitoring while dictating

The recording can be monitored through earphones. Connect a Sony DE-35, DE-36 or MDR-U10M earphones (not supplied) to the EARPHONE jack located on the left side of the unit. Adjust VOLUME if required.

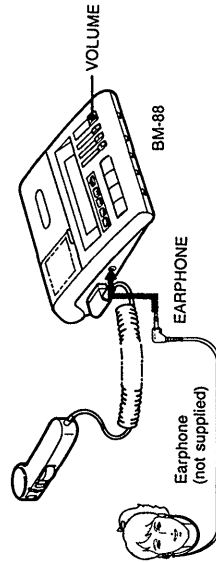

Earphone (not supplied)

EARPHONE

BM-88

VOLUME

Dictation (BM-88 only)

■ **Quick reviewing (playback)/correcting the dictated material**
 You can easily listen to the dictated material and correct it if required.

- 1 Keep the function selector of the HU-80 pressed down toward B. SPACE to rewind the tape.
- 2 Release the selector. Playback of the dictation begins.
- 3 When the reviewing is completed, set the function selector to DICT to proceed with the dictation.

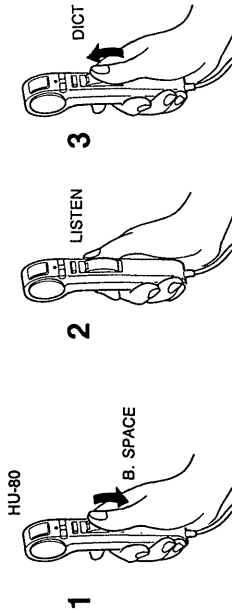

For fast winding of the tape, keep the FWD SPACE button of the HU-80 pressed until the desired portion is reached.

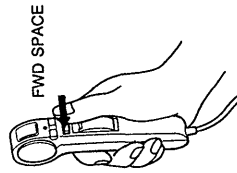

■ **When you have finished dictating**
 Hand the cassette to your secretary without rewinding the tape.

Tips for More Efficient Dictation

Before you start dictation

- Organize your thoughts.
- Make notes or an outline of what you want to dictate.
- Check that the cassette is erased. (See page 7.)

When you dictate

- Identify yourself: (Name, department, phone number)
- Indicate the type of dictation. (Memo, letter, etc.)
- Give transcribing instructions. (Type of stationery, number of copies and who they are for, envelopes, etc.)
- Specify distribution (Names, addresses, etc.)

During dictation

- Relax and speak clearly, at normal speed.
- Short sentences are best.
- Include punctuation.
- Spell difficult or unusual words.
- Correct your mistakes. (Review and re dictate, or use SEC signal to alert the transcriptionist of changes or corrections.)
- At the end of each document, record an LTR signal.

Transcription (BM-77/BM-88)

To use the unit as a transcribing machine, connect the FS-75 foot control unit (not supplied).
For connection, see page ④.

Operation

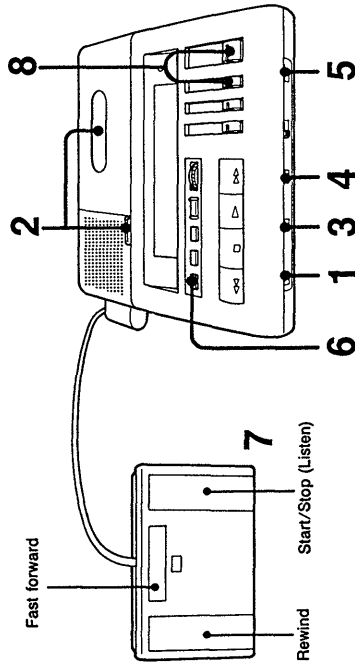

- 1 Set **STANDBY/ON** to **ON**.
- 2 Insert a cassette. (See page ③.)
- 3 Set **SPEAKER** to **BUILT-IN**. (BM-88 only)
- 4 Set **AUTO STOP** to **OFF**. (See page ②.)
- 5 Set **TAPE SPEED** to the same tape speed as that used for recording (dictation).

To stop the tape
Release the pedal.

To rewind the tape
Keep the left side of the FS-75 pedal depressed.

To rapidly advance the tape
Keep the center top of the FS-75 pedal depressed.

6 To check the recorded material by using the SCAN function:

Press **SCAN** for a second.
SCAN and **REMAINING** appear on the display and the tape starts to be rewound.

When the tape reaches the beginning of the dictated material, a beep tone is heard and the unit automatically shuts off. When the tape is completely rewound, the total dictated time and the recorded time of the first document are displayed. The numbers of documents and special instructions recorded on the tape are also displayed on the display.

Disappears when the unit shuts off.

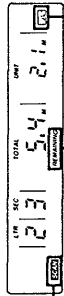

While **REMAINING** is displayed, the numbers on the display window indicate the amount of tape left. This is convenient to know the remaining amount of dictation when transcribing.
While **REMAINING** is displayed, dictating, telephone recording and recording of LTR and SEC signals cannot be performed.
Press **RESET** or the eject button. **REMAINING** will disappear.

When the tape reaches the tape top, this mark blinks while a long beep tone is heard and then lights up.

The above example of the counter indicates that the cassette has 2 documents and 3 special instructions. Total recorded time of the dictation is approx. 5.4 minutes and the recorded time of the first document is approx. 2.1 minutes.

Notes

- To stop scanning, press **STOP**.
- When the **AUTO STOP** switch is set to **ON**, the tape automatically stops at each electronic index signal previously recorded on the tape while scanning. This is convenient to locate the beginning of each document or special instruction.
- To restart scanning after it is stopped at the electronic index signal, press the **SCAN** or **REW** button.

7 Keep the right side of the FS-75 pedal depressed to listen to the tape.

8 Adjust VOLUME and TONE.

As to the display window, refer to page ④.

Transcription

Notes on the time counter

While REMAINING is displayed (in scanning mode or in rewind mode after scanning) and the unit is stopped automatically when the LTR signal is detected, the number on the UNIT counter will be reset to 0.0 M after blinking for about 3 seconds to read the amount of the document.

Scan-top function

When the tape is advanced rapidly (in fast forward mode after scanning) while REMAINING is displayed, the tape will stop automatically at the portion from which the scanning was started. In this case, a beep tone is heard and the — (minus) mark on the TOTAL counter blinks for about 3 seconds and then stops blinking.

Convenient Functions

■ AUTO STOP function

With the AUTO STOP function, recorded documents and instructions can be located without the user's having to listen to the entire tape.

This function activates only in rewind, fast forward or scanning mode.

When the AUTO STOP switch is set to ON, the tape automatically stops at each electronic index signal previously recorded on the tape. (See "To record LTR and SEC signals" on page 6.)

When an LTR signal is detected, the LTR document counter number increases or decreases and blinks for approximately 3 seconds, and a beep tone is heard. The tape stops automatically.

When the SEC signal is detected, the special instruction counter number increases or decreases and blinks for approximately 3 seconds, and a beep tone is heard. The tape stops automatically.

When the AUTO STOP switch is set to OFF, the numbers on the LTR (document) and SEC (special instruction) counters increase or decrease and blink when an LTR or SEC signal is detected, but the tape does not stop.

Note

The tape does not stop at the LTR or the SEC signal even if the AUTO STOP switch is set to ON while the FF or REW button is continuously depressed.

■ Speed control (BM-77)

Set the SPEED CONTROL selector* to ON to adjust the SPEED control. The tape can be played back at a speed faster than normal. Set the SPEED CONTROL selector to OFF to transcribe the dictated material at the normal speed.

* Tape speed can be changed in the range of approximately -20% to +80% with the use of the SPEED control.

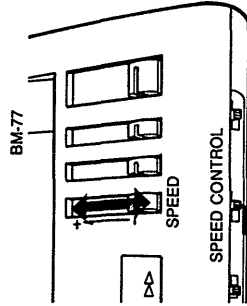

■ VSC (Variable Speech Control) (BM-88)

The tape can be played back at a speed faster than normal without distorting the voice. Set the SPEED CONTROL selector* to VSC and adjust both the SPEED and PITCH controls. Set the SPEED CONTROL selector to ON to adjust the SPEED control only. When the SPEED CONTROL switch is set to OFF, the tape moves at the normal speed regardless of the position of the SPEED and PITCH controls.

* Tape speed can be changed in the range of approximately -20% to +80% with the use of the SPEED control.

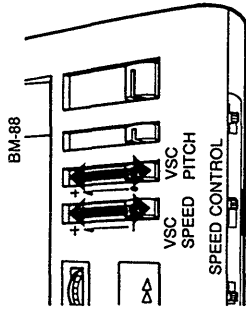

■ Auto backspace function

This control operates only when the FS-75 foot control unit is connected. With the use of the REVERSE TIME control, the tape is rewound a little each time it is stopped. Then, the last few recorded words can be reviewed when you resume listening. Adjust the REVERSE TIME control to determine the length of tape to be rewound. At "9" position, the tape is rewound so that the dictated material can be reviewed for about 5 seconds. At "0" position, the tape stops without being rewound at all.

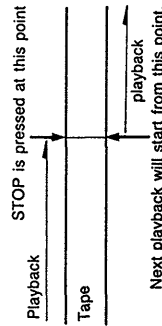
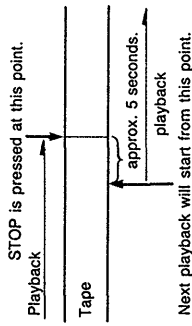
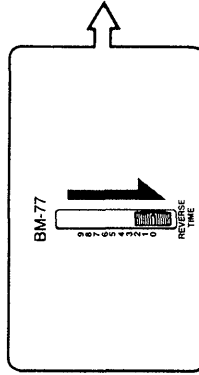
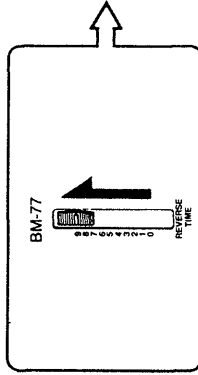

Set the REVERSE TIME control to the desired position and keep the right side of the pedal depressed to listen to the tape.

■ Tape transport operation

BM-77 BM-88	HU-80 (for BM-88 only)	FS-75
Press ◀◀ REW.	Keep the function selector pressed down toward B. SPACE.	Keep the left side of the pedal depressed.
Press ■ STOP.	Set the function selector to STOP.	Release the pedal.
Press ▶▶ LISTEN.	Set the function selector to LISTEN.	Keep the right side of the pedal depressed.
Press ▶▶▶ FF.	Keep the FWD SPACE button pressed.	Keep the top center of the pedal depressed.

■ Notes

- When a button is pressed while detecting the index signal during playback, the switching time of the operation modes may be delayed and a beep tone is heard. (See page 29.)
- When a music cassette or a monaural cassette is wound rapidly (in fast forward or rewind mode), the switching time of the operation modes may be delayed.

■ Private listening

Connect a Sony DE-35, DE-36 or MDR-U10M earphones (not supplied) to the EARPHONE jack. The sound will be heard through the earphones and speaker sound will be disconnected.

■ Selecting the speaker (BM-88 only)

You can listen to the dictated material through the built-in speaker or the speaker on the HU-80 by switching the SPEAKER selector to BUILT-IN or HAND.



■ Notes

- E-INDEX signal of the Sony conventional models BM-12, BM-17, BM-18 and so on corresponds to the LTR signal of the models BM-77 and BM-88.
- LTR/SEC signals and E-INDEX signal do not correspond to the cue signals used for consumer type tape recorder.

Tips on Transcription

- Before typing, check the recorded time of the dictation and the number of LTR and SEC signals recorded on the cassette using the SCAN function.
- Erase the tape when transcription is finished.

The recording can be erased rapidly.

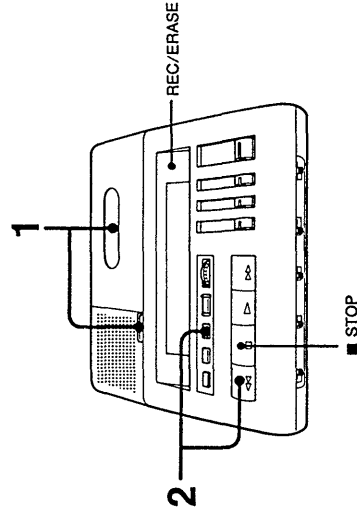

- 1 Insert the cassette with the side to be erased up.**
Be sure not to rewind the tape after transcribing. The end portion of the dictated material to be erased should be positioned at the recording head.
- 2 Keep ERASE pressed and then press ◀◀ REW.**
The REC/ERASE lamp lights up (BM-88 only) and ERASE appears on the display window. The portion of the tape being rewound is erased.

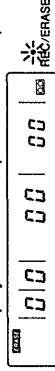















To stop the tape
Press ■ STOP.

For easier and quicker erasure of the entire cassette, use Sony BE-9H cassette eraser (not supplied).

Alarm System

An alarm sounds and an indication appears on the display window in the following situations.

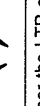
Alarm system	Situation	To release alarm system
When you press a button,  	• No cassette is inserted. • The cassette's safety tabs have been removed.	First, release the button, then • Insert a cassette. • Insert a new cassette or cover the safety slot.
The unit shuts off.  	End of tape The tape is torn	Rewind the tape. Insert a new cassette.
When you press a button,  	When you attempt to record while REMAINING is displayed. (BM-88 only)	Clear the REMAINING mark by pressing the RESET or eject button.
While recording,  	Approx. 3 minutes before the end of tape while recording. (BM-88 only)	Press ▶ LISTEN to stop alarm sound. Stop recording and insert a new cassette.
The unit shuts off during FF mode.  	End of recording. (BM-88 only)	The REC END disappears and alarm stops automatically when about 3 seconds have passed.
"E" appears.	The number of LTR or SEC signal exceeds 9.	Do not press LTR or SEC button more than 9 times.

Alarm system	Situation	To release alarm system
The unit shuts off during FF mode. The — (minus) mark on the TOTAL counter blinks. 	While REMAINING is displayed, the unit is rapidly advanced and automatically stopped at the portion from which the scanning was started.	The minus mark stops blinking and lights up automatically when about 3 seconds have passed.
The unit shuts off.  Number of LTR or SEC blinks.	Either LTR of SEC are detected while the tape is wound rapidly (in fast forward, rewind or scanning mode) and the AUTO STOP switch is set to ON.	The number of LTR or SEC stops blinking and lights up automatically when about 3 seconds have passed.
When you press a button while playing back the tape.  	Either the LTR or SEC signals are detected on the tape.	Although the switching time of the operation modes may be delayed, the button is memorized and the unit operates within a second.
Either the LTR or SEC buttons are pressed while playing back the tape. 	Either the LTR or SEC signals are detected on the tape. (BM-88 only)	Release the button. Play back the tape continuously for more than 6 seconds and then, press the button again.

Examples of Dictation and Transcription

Example of Dictation (BM-88 only)

Set the function selector of the HU-80 to DICT.

Press SEC.

"This is a letter. Type it up and send it by express."

"Today's date is August 17, 1990.

This letter is for Mr. Alan R. Jefferson
Pyrene House, Sunbury on Thames,
Middlesex, TW16 7AT, U.K.

Dear Sir,

We received your order for"

Press SEC.

"under line
POL-L-5049-D3581", "quantity 270,000 today.
Shipment can be made within two weeks by Air.
Please accept our thanks for your order.
Faithfully yours,

John S. Smith
Sales Manager
U.K.G. Ltd."

Press LTR.

Set the function selector of the HU-80 to STOP.

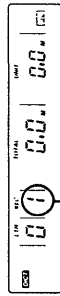

Blinks for approx. 3 seconds and stops blinking.

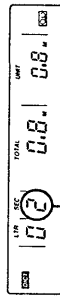

Blinks for approx. 3 seconds and stops blinking.

This number is reset to 0.0 when the LTR button is pressed and increases until the LTR button is pressed again.

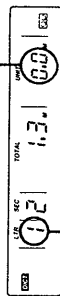

Blinks for approx. 3 seconds and stops blinking

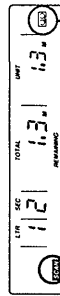
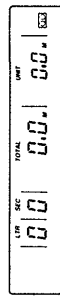

When the tape reaches the beginning, SCAN disappears and the SCAN blinks for about 3 seconds and then stops blinking.

Keep the right side of the FS-75 pedal depressed.

Tape playback starts.

Mr. Alan R. Jefferson
Pyrene House, Sunbury on Thames,
Middlesex, TW16 7AT, U.K.

Dear Sir,

We received your order for POL-L-5049-D3581, quantity 270,000 today. Shipment can be made within two weeks by Air.

Please accept our thanks for your order.

Faithfully yours,

John S. Smith
Sales Manager
U.K. G. Ltd.

JSS/hh

August 17, 1990

1.3.0.0

Blinks for approx. 3 seconds and stops blinking.

0.5.0.0

Blinks for about 3 seconds and then stops blinking.

0.0.0.0

Blinks for approx. 3 seconds and stops blinking

The number is reset.



Stop the tape when the transcription is finished.

If desired, keep ERASE pressed and then, press ◀ REW to erase the cassette.

Other Convenient Functions

Transcribing a Microcassette

With Sony MA-50 microcassette adaptor (not supplied), transcription from a microcassette is possible.

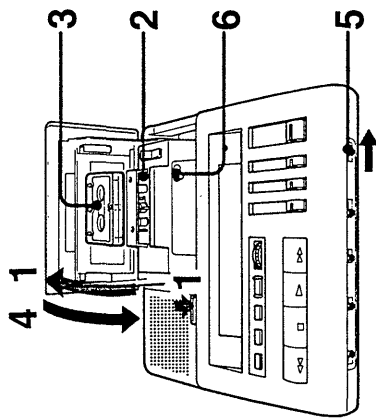

- 1 Press the eject button to open the cassette compartment and press the cassette holder in the direction of the arrow to further open the compartment.
- 2 Install the MA-50 microcassette adaptor in the cassette compartment.
For details, refer to the instruction manual of the MA-50.
- 3 Insert a microcassette in the MA-50.
- 4 Close the cassette holder firmly toward the MA-50.
- 5 Set TAPE SPEED of the BM-77/BM-88 to 4.8.
- 6 Set the tape speed of the MA-50 to 2.4 or 1.2.
Turn on the MA-50.

While using the MA-50, the display window does not work properly.

When the MA-50 is not used
Remove it.

To remove the MA-50
Lift it up.

Notes

- Turn off the MA-50 when it is inserted or removed from the unit, or when the microcassette is wound rapidly (in fast forward or rewind mode).
- As to the insertion and removal of microcassette, refer to the instruction manual of the MA-50.

Telephone Recording (BM-88 only)

To record telephone conversation, connect the optional TL-2 message coupler* to the TELEPHONE PICKUP jack. For further details, refer to the instruction manual of the message coupler.

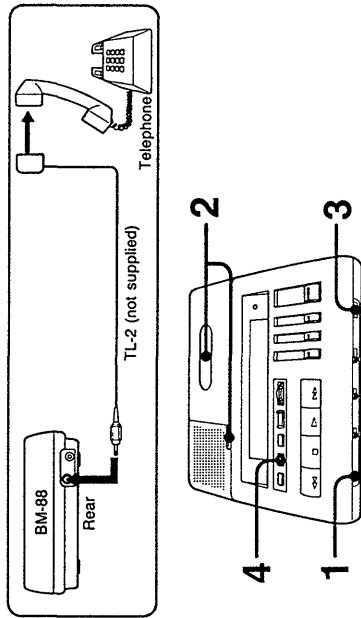

* The TL-2 message coupler cannot be used on some telephones.

- 1 Set STANDBY/ON to ON.
- 2 Insert a cassette.
- 3 Set TAPE SPEED to the desired tape speed.
- 4 Keep TEL REC pressed for more than a second.
Telephone recording begins. REC/ERASE lamp flickers and TEL appears on the display window.

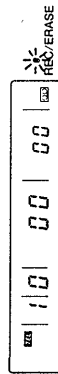

To stop the tape
Press ■ STOP.

At the beginning of telephone recording
LTR signal is automatically recorded.
While the LTR signal is being recorded (for about 3 seconds), the unit cannot be stopped even though STOP button is pressed.

During telephone recording
Only the LTR, SEC and STOP buttons are operative.

SECTION 3 MECHANICAL ADJUSTMENTS

PRECAUTION

1. Clean the following parts with a denatured alcohol-moistened swab:
 - record/playback head pinch roller
 - erase head rubber belts
 - capstan
2. Demagnetize the record/playback head with a head demagnetizer.
3. Do not use a magnetized screwdriver for the adjustment.
4. After the parts adjustments, apply suitable locking compound to the parts adjusted.
5. The adjustments should be performed with the rated power supply voltage unless otherwise noted.

Torque Measurement

Mode	Cassette type torque meter	Meter reading
Forward	CQ-102C	20-45g•cm (0.28-0.62oz•inch)
Fast Forward, Rewind	CQ-201B	80-200g•cm (1.11-2.78 oz•inch)
Back Tension	CQ-102C	1-4g•cm (0.014-0.056oz•inch)

Tape Tension Measurement

Cassette type tension meter	Meter reading
CQ-403A	100-170g (3.5-6.0oz)

Forward Torque Adjustment

Mode: Forward

Cassette type torque meter	Torque	Procedure
CQ-102C	20-45g•cm (0.28-0.62 oz•inch)	Adjust the forward torque by replace the spacer shown in below chart.

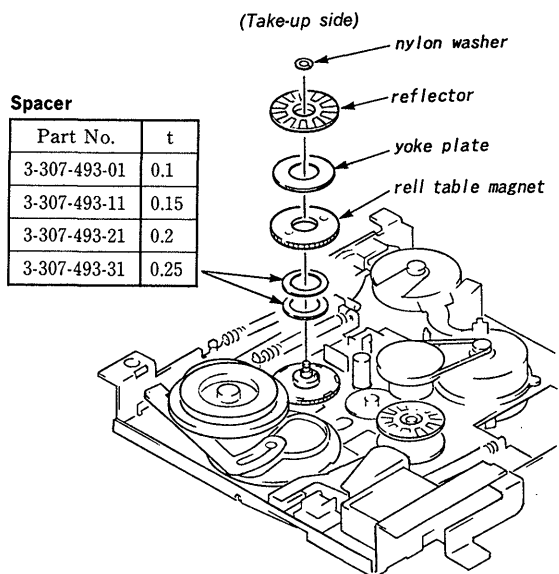

Head Height Adjustment

Procedure :

1. Insert the mirror cassette (CQ-009C).
2. In playback mode and viewing from the front, adjust the head heights to eliminate tape curl and tape twist as shown by arrows.
3. After the adjustments, apply suitable locking compound to screws.

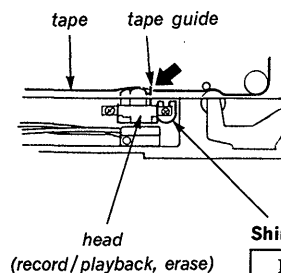

Shim, head height adjustment

Part No.	t
3-578-138-01	0.1
3-578-138-11	0.2

SECTION 4 ELECTRICAL ADJUSTMENTS

PRECAUTION

- Switches and controls should be set to the positions as follows unless otherwise specified.

• Switch positions

STANDBY ON switch	: ON
AUTO STOP switch	: ON
TONE control	: max.(H)
VOLUME control	: mechanical mid
SPEED CONTROL switch	: OFF
TAPE SPEED switch	: 4.8
REVERSE TIME control	: 0

- Standard Input Level :

TELEPHONE PICKUP jack : 300 Ω 0.77mV(-60dB)

- Standard Output Level:

Speaker : 8 Ω 0.775V(0dB)

Record/playback Head Azimuth Adjustment

Procedure :

- Mode : Playback (LISTEN)

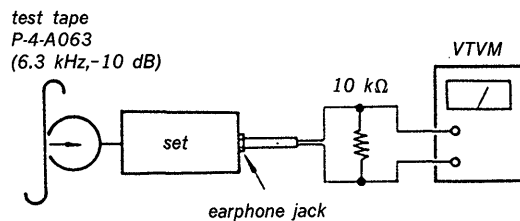

- Turn the adjustment screw to obtain the maximum reading on VTVM.
Adjustment should be finished with the screw in tightening direction.
- After the adjustment, lock the adjustment screw with suitable locking compound.

Adjustment Location : playback head

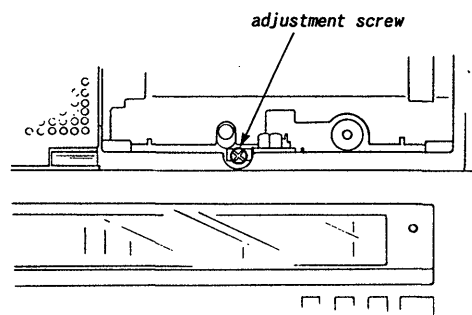

Tape Speed Adjustment

Setup :

Mode : Playback (LISTEN)

test tape
WS-48
(3 kHz, 0 dB)
tape end portion

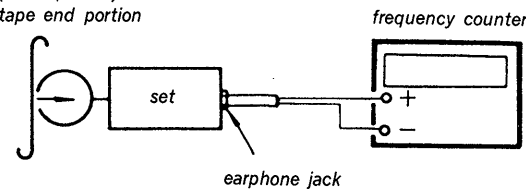

Procedure :

- SPEED CONTROL switch : OFF
TAPE SPEED switch : 2.4
Adjust RV601 to obtain a 1515 Hz frequency reading.
- SPEED CONTROL switch : OFF
TAPE SPEED switch : 4.8
Adjust RV602 to obtain a 3030 Hz frequency reading.
- SPEED CONTROL switch : ON
VSC SPEED control : max. (+)
Adjust RV603 to obtain a 5550 Hz frequency reading.

Adjustment Location : servo board

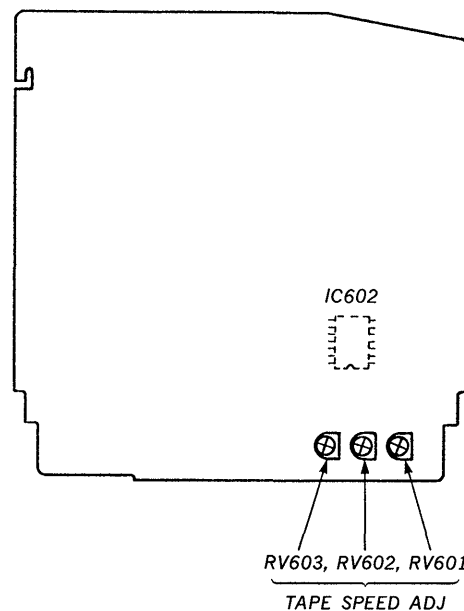

SECTION 5 DIAGRAMS

5-1. SEMICONDUCTOR LEAD LAYOUTS

μ PC2406HF

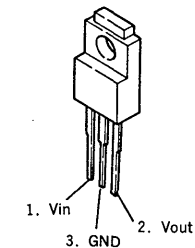

GP-2S09-C

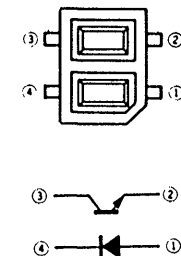

DTA114YK DTC114EK DTC143TK DTC144EK 2SB624-BV345 2SC2712-YG 2SD1048-X7

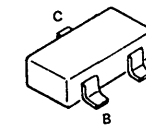

MA152WK

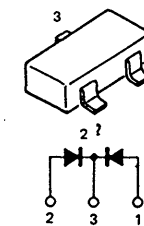

2SB798-DL 2SD999-CLCK

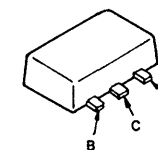

RD3. 3M-B1

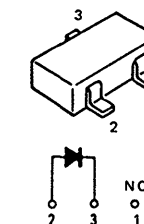

DWA010

- cathode
- cathode
- anode
- anode

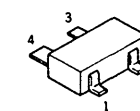

10E2

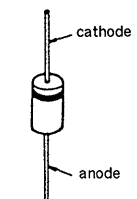

D1F10

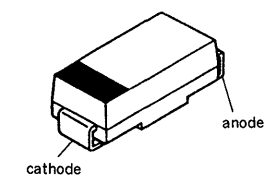

5-2. PRINTED WIRING BOARDS

• Semiconductor Location

Ref. No.	Location
D107	C-6
D108	E-14
D109	D-14
D110	D-15
D111	B-14
D112	B-14
D113	D-15
D114	D-14
D117	B-6
D601	D-29
D602(#1)	G-22
D602(#2)	G-33
D604(#1)	G-23
D604(#2)	F-33
D605	A-29
D606(#1)	G-23
D606(#2)	G-33
IC101	G-6
IC102	H-9
IC103	H-6
IC106	F-7
IC111	C-3
IC112	E-12
IC601	C-28
IC602	G-24
IC603	C-24
IC604	D-27
Q103	G-7
Q107	F-9
Q111	G-7
Q113	D-12
Q114	D-12
Q115	B-12
Q116	F-6
Q301	G-7
Q601	D-28
Q602	C-28
Q603	H-29
Q604	H-29
Q605	G-29
Q606	G-30
Q607	E-23
Q608	E-30
Q609	E-23
Q610(#1)	F-23
Q610(#2)	F-32
Q611	D-30
Q612(#1)	F-23
Q612(#2)	F-33
Q613	E-23
Q614	F-29
Q615	F-29
Q616	E-29
Q617	F-30
Q618	D-28
Q619	B-27

* 1: Used in servo board part number suffix -11.
 * 2: Used in servo board part number suffix -12.

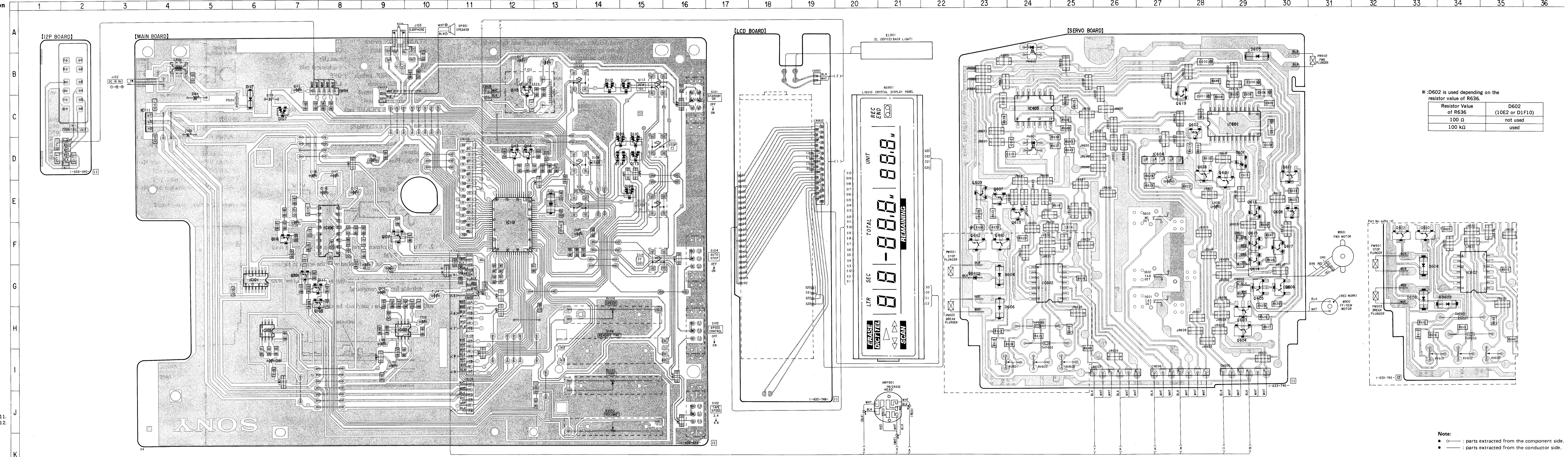

* :D602 is used depending on the resistor value of R636.

Resistor Value of R636	D602 (10E2 or D1F10)
100 Ω	not used
100 kΩ	used

Note:
 ○ : parts extracted from the component side.
 ● : parts extracted from the conductor side.

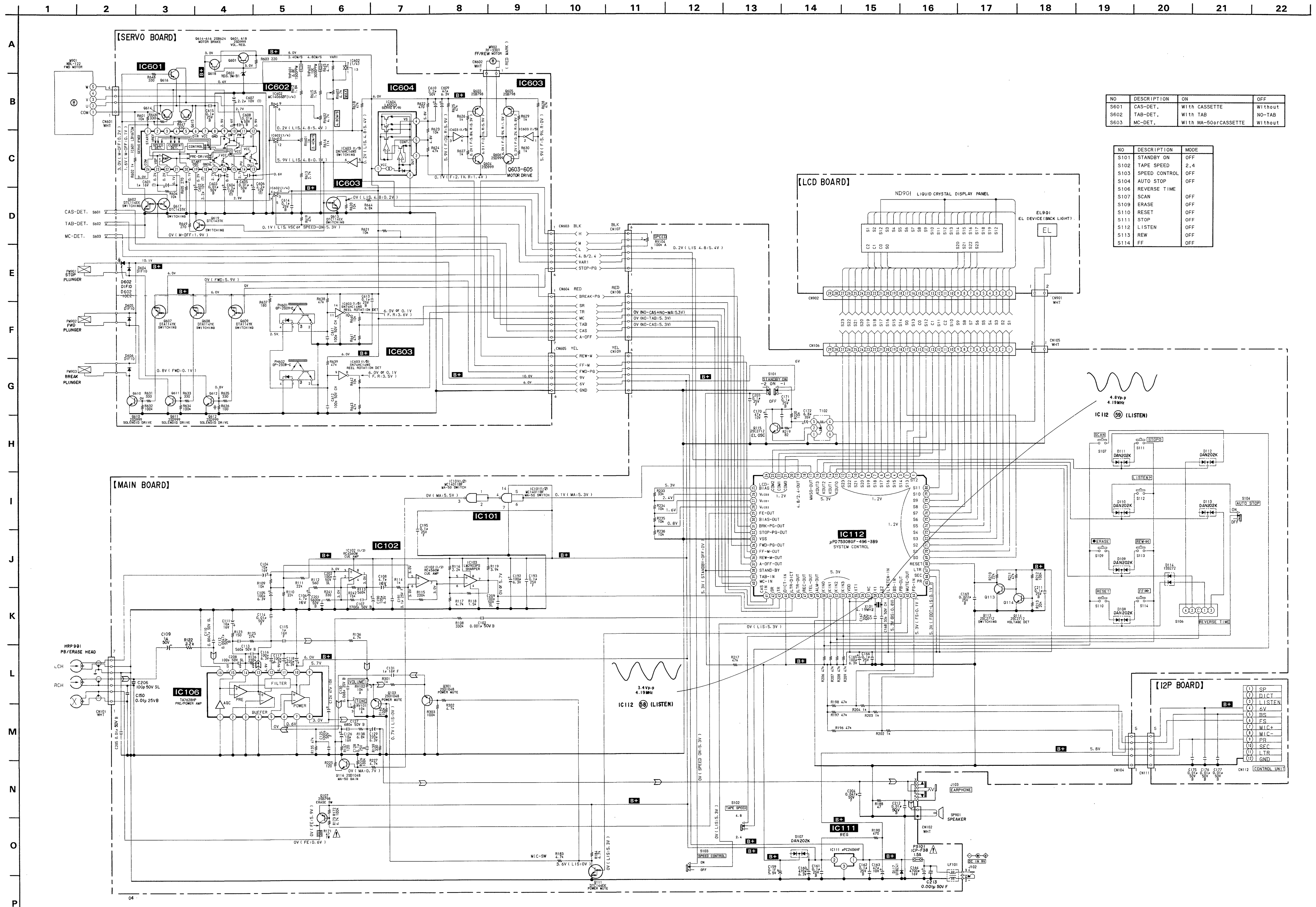

NO	DESCRIPTION	ON	OFF
S601	CAS-DET.	With CASSETTE	Without
S602	TAB-DET.	With TAB	NO-TAB
S603	MC-DET.	With MA-50orCASSETTE	Without

NO	DESCRIPTION	MODE
S101	STANDBY ON	OFF
S102	TAPE SPEED	2, 4
S103	SPEED CONTROL	OFF
S104	AUTO STOP	OFF
S106	REVERSE TIME	OFF
S107	SCAN	OFF
S109	ERASE	OFF
S110	RESET	OFF
S111	STOP	OFF
S112	LISTEN	OFF
S113	REW	OFF
S114	FF	OFF

Note 1:
S 106 (REVERSE TIME) MODE
S106 position ○ : ON

	0	1	2	3	4	5	6	7	8	9
Between C and 1	○	○	○	○	○	○	○	○	○	○
Between C and 2	○	○	○	○	○	○	○	○	○	○
Between C and 3	○	○	○	○	○	○	○	○	○	○
Between C and 2	○	○	○	○	○	○	○	○	○	○

Note 2:
T: Tantalum capacitor
PT: Mylar capacitor
MF: Metallized film capacitor
other: Electrolytics and Ceramic capacitor

*: D602 is used depending on the resistor value of R636.

Resistor Value of R636	D602 (10E2 or D1F10)
100 Ω	not used
100 kΩ	used

Note:
• All capacitors are in μF unless otherwise noted. pF: μF
• All resistors are in Ω and 1/4W or less unless otherwise specified.
• : nonflammable resistor.

Note:
The components identified by mark or dotted line with mark are critical for safety. Replace only with part number specified.

Note:
Les composants identifiés par une marque sont critiques pour la sécurité. Ne les remplacer que par une pièce portant le numéro spécifique.

- : adjustment for repair.
- Power voltage is fed with supplied AC adaptor (AC-980).
- Voltage and waveforms are dc with respect to ground under no-signal conditions.
- mark : STOP (CASSETTE IN, TAPE SPEED); 4.8, MOTOR ON
- LIS : LISTEN
- FE : FAST-ERASE
- 2.4 : 2.4cm/s
- F : FF
- R : REW
- MA : MA-50 (micro cassette adaptor)
- FWD : LISTEN, DICT, TEL, LTR, SEC
- NO-CAS : no cassette
- NO-TAB : with safety tabs removed

- Voltages are taken with a VOM (Input Impedance 10MΩ). Voltage variations may be noted due to normal production tolerances.
- Waveforms are taken with a oscilloscope. Voltage variations may be noted due to normal production tolerances.
- Signal path.
- : PB

SECTION 6 EXPLODED VIEWS

NOTE:

- The mechanical parts with no reference number in the exploded views are not supplied.
- The construction parts of an assembled part are indicated with a collation number in the remark column.
- Items marked "★" are not stocked since they are seldom required for routine service. Some delay should be anticipated when ordering these items.

- Due to standardization, parts with part number suffix -XX and -X may be different from the parts specified in the components used on the set.
- Color Indication of Appearance Parts
Example:
(RED) ... KNOB, BALANCE (WHITE)
↑ ↑
Cabinet's Color Parts' Color

The components identified by mark ▲ or dotted line with mark ▲ are critical for safety. Replace only with part number specified.

Les composants identifiés par une marque ▲ sont critiques pour la sécurité. Ne les remplacer que par une pièce portant le numéro spécifié.

6-1. CABINET SECTION

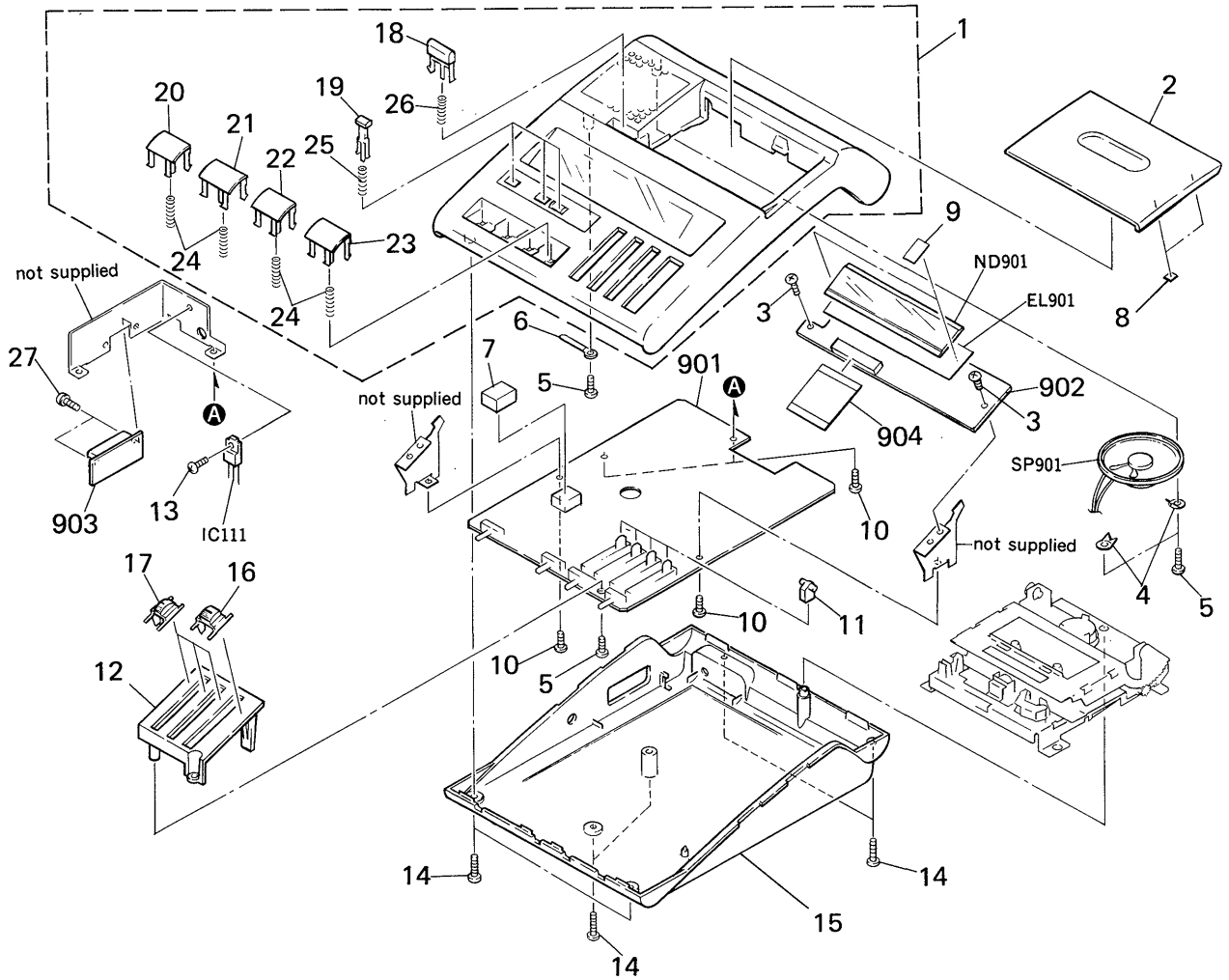

Ref.No	Part No.	Description	Remarks	Ref.No	Part No.	Description	Remarks
1	X-3323-555-1	CABINET (FRONT) ASSY	18-26	19	3-323-695-01	BUTTON	
2	X-3323-532-1	LID ASSY, CASSETTE		20	3-323-698-01	BUTTON (REW)	
3	7-682-647-09	SCREW +PS 3X6		21	3-323-697-01	BUTTON (STOP)	
4	3-845-110-00	RETAINER, SPEAKER		22	3-323-698-11	BUTTON (LISTEN)	
5	7-685-646-79	SCREW +BVTP 3X8 TYPE2 N-S		23	3-323-698-21	BUTTON (FF)	
6	*3-701-822-00	HOLDER, WIRE		24	3-323-696-01	SPRING, COMPRESSION	
7	*3-323-675-01	PLATE, SHIELD		25	3-323-694-01	SPRING, COMPRESSION	
8	3-363-245-01	CUSHION		26	3-323-692-01	SPRING, COMPRESSION	
9	9-911-838-XX	CUSHION, MAGNET		27	7-628-254-20	SCREW +PS 2.6X8	
10	7-682-547-04	SCREW +BVTT 3X6 (S)		28	3-362-436-01	DAMPER	
11	*3-323-679-01	BUSHING		901	*A-3060-189-A	MOUNTED PCB, MAIN	
12	3-359-104-01	GUIDE, KNOB		902	*1-633-748-11	PC BOARD, LCD	
13	7-682-548-04	SCREW +B 3X8		903	*1-636-640-11	PC BOARD, 12P	
14	7-685-648-79	SCREW +BVTP 3X12 TYPE2 N-S		904	*1-590-284-11	WIRE, FLAT TYPE 29 CORE	
15	X-3323-554-1	CABINET (REAR) ASSY		EL901	1-808-962-11	DEVICE, EL	
16	X-3323-535-1	KNOB (VOLUME) ASSY		IC111	8-759-148-79	IC UPC2406HF	
17	X-3323-536-1	KNOB (TONE) ASSY		ND901	1-808-961-11	DISPLAY PANEL, LIQUID CRYSTAL	
18	3-323-693-01	BUTTON (EJECT)		SP901	1-544-324-11	SPEAKER	

**6-2. MECHANISM DECK SECTION (1)
(MB-88-59)**

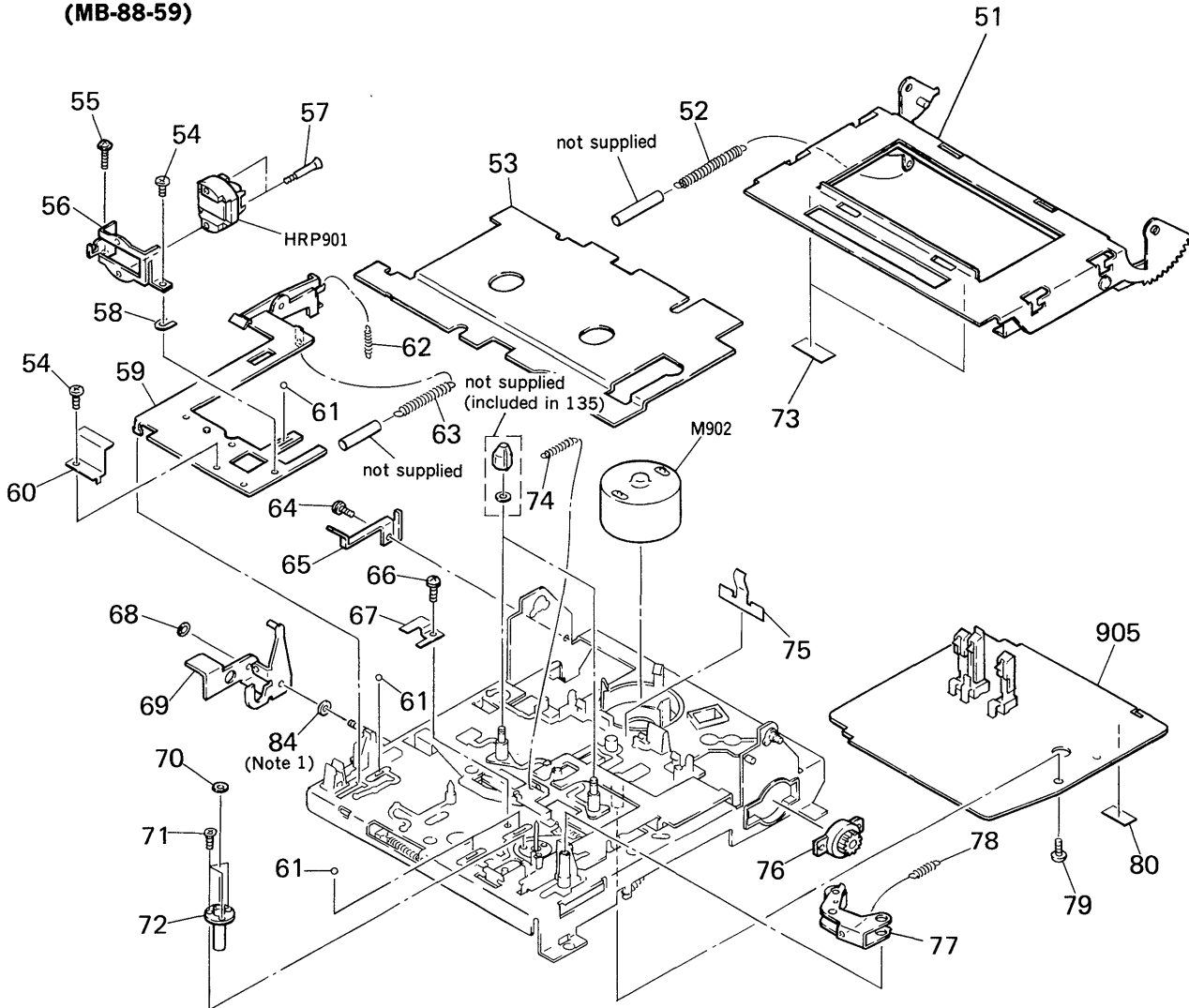

Note 1:
No. 84 has not been used on production.

Ref.No	Part No.	Description	Remarks	Ref.No	Part No.	Description	Remarks
51	X-3323-552-1	HOLDER ASSY, CASSETTE		68	3-307-948-21	WASHER, NYLON	
52	3-359-163-01	SPRING, TENSION		69	*X-3323-551-1	LEVER (EJECT) ASSY	
53	3-359-159-01	PANEL (REEL)		70	3-325-698-01	RING, RETAINING	
54	7-627-553-27	SCREW,PRECISION +P 2X2.5		71	7-627-551-58	SCREW,PRECISION +P 1.4X3	
55	7-621-771-06	SCREW, LOCK		72	3-359-152-01	BEARING, CAPSTAN	
56	*3-359-144-01	HOLDER (HEAD)		73	3-363-246-01	CUSHION (CH)	
57	4-920-347-01	SCREW, HEAD		74	3-305-902-00	SPRING, TENSION	
58	3-578-138-01	SHIM (T=0.1)		75	3-359-125-01	SPRING (CASSETTE RETAINER)	
	3-578-138-11	SHIM (T=0.2)		76	3-343-248-01	DAMPER (P), SMALL	
59	*X-3323-549-1	CHASSIS ASSY, HEAD		77	X-3323-550-1	PINCH LEVER ASSY	
60	*3-359-143-01	PLATE, SHIELD		78	3-359-164-01	SPRING, TENSION	
61	7-671-111-11	STEEL, BALL 1.5MM		79	7-685-133-19	SCREW +BTP 2.6X6 TYPE2 N-S	
62	4-858-478-00	SPRING, TENSION		80	3-831-441-11	CUSHION (B)	
63	3-583-501-00	SPRING, TENSION		84	3-701-439-11	WASHER (T=0.25)	
64	7-628-253-00	SCREW +PS 2X4		905	*A-3089-549-A	MOUNTED PCB BLOCK ASSY, SERVO	
65	*3-359-126-01	SPRING (CASSETTE HOLDER)		HRP901	1-543-564-11	HEAD, MAGNETIC (PB/ERASE)	
66	7-628-253-90	SCREW +PS 2.6X4		M902	X-3362-206-1	MOTOR ASSY (F/R)	
67	3-323-520-01	SPRING					

6-3. MECHANISM DECK SECTION (2)
(MB-88-59)

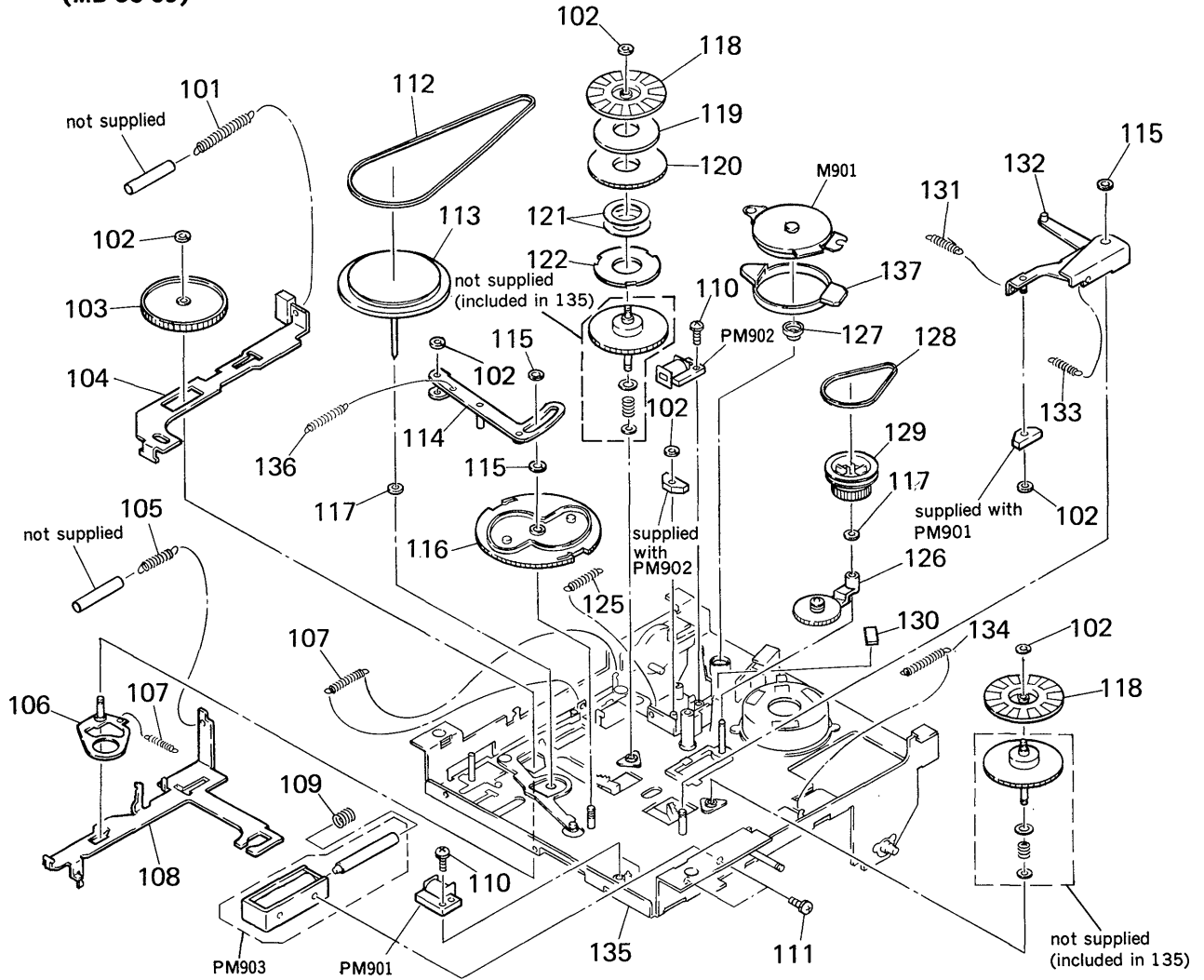

Ref.No	Part No.	Description	Remarks	Ref.No	Part No.	Description	Remarks
101	3-359-161-01	SPRING, TENSION		121	3-307-493-01	SPACER (T=0.1)	
102	3-307-948-01	WASHER, NYLON			3-307-493-11	SPACER (T=0.15)	
103	3-362-606-01	GEAR (FWD IDLER) (T=0.4)			3-307-493-21	SPACER (T=0.2)	
104	*X-3323-544-1	PLATE ASSY, FUNCTION, FWD			3-307-493-31	SPACER (T=0.25)	
105	3-359-162-01	SPRING, TENSION		122	3-561-827-00	PLATE (A), HYSTERESIS	
106	X-3323-501-1	LEVER ASSY, F.I		125	3-309-031-00	SPRING, TENSION	
107	3-509-127-00	SPRING, TENSION		126	X-3323-547-1	GEAR (F/R) ASSY	
108	*3-359-153-01	LEVER (FWD)		127	*3-362-434-01	CUSHION (M2)	
109	3-359-160-01	SPRING, COMPRESSION		128	3-359-157-01	BELT (F/R)	
110	7-628-253-40	SCREW +PS 2X10		129	3-359-156-01	IDLER (F/R)	
111	7-628-253-90	SCREW +PS 2.6X4		130	3-362-473-01	CUSHION (M3)	
112	3-359-158-01	BELT (FWD)		131	3-533-223-00	SPRING, TENSION	
113	X-3362-056-1	FLYWHEEL ASSY		132	*X-3323-543-1	PLATE ASSY, FUNCTION, STOP	
114	*X-3323-545-1	ARM (FWD DRIVING) ASSY		133	3-542-649-01	SPRING, TENSION	
115	3-307-948-21	WASHER, NYLON (T=0.4)		134	3-642-490-00	SPRING, TENSION	
116	3-359-154-01	GEAR (CAM)		135	*A-3035-282-A	CHASSIS ASSY	
117	3-701-437-01	WASHER (T=0.13)		136	3-555-212-00	SPRING, TENSION	
118	3-359-155-01	REFLECTOR		137	*3-362-433-01	CUSHION (M)	
119	3-307-313-00	PLATE, YOKE		M901	1-541-748-11	MOTOR (FWD)	
120	3-307-953-00	MAGNET, REEL TABLE		PM901	1-454-459-21	SOLENOID, PLUNGER	
				PM902	1-454-459-21	SOLENOID, PLUNGER	
				PM903	1-454-509-11	SOLENOID, PLUNGER	

SECTION 7 ELECTRICAL PARTS LIST

NOTE:

- Due to standardization, replacements in the parts list may be different from the parts specified in the diagrams or the components used on the set.
- Items marked "★" are not stocked since they are seldom required for routine service. Some delay should be anticipated when ordering these items.
- If there are two or more same circuits in a set such as a stereophonic machine, only typical circuit parts may be indicated and capacitors and resistors in other same circuits may be omitted.

CAPACITORS:
MF: μ F, PF: μ PF.

RESISTORS

- All resistors are in ohms.
- F: nonflammable

COILS

- MMH: mH, UH: μ H

SEMICONDUCTORS

In each case, U: μ , for example:
UA...: μ A..., UPA...: μ PA...,
UPC...: μ PC, UPD...: μ PD...

The components identified by mark Δ or dotted line with mark Δ are critical for safety.
Remplace only with part number specified.

Les composants identifiés par une marque Δ sont critiques pour la sécurité.
Ne les remplacer que par une pièce portant le numéro spécifié.

Ref.No	Part No.	Description			
901	*A-3060-189-A	MOUNTED PCB, MAIN			
902	*1-633-748-11	PC BOARD, LCD			
903	*1-636-640-11	PC BOARD, 12P			
904	*1-590-284-11	WIRE, FLAT TYPE 29 CORE			
CAPACITOR					
C102	1-163-009-11	CERAMIC CHIP	0.001MF	10%	50V
C104	1-126-157-11	ELECT	10MF	20%	16V
C105	1-124-225-00	ELECT	100MF	20%	6.3V
C106	1-126-094-11	ELECT	4.7MF	20%	16V
C107	1-163-014-00	CERAMIC CHIP	0.0027MF	10%	50V
C108	1-126-094-11	ELECT	4.7MF	20%	16V
C109	1-126-160-11	ELECT	1MF	20%	50V
C110	1-162-625-11	CERAMIC CHIP	0.0047MF	5%	50V
C111	1-126-157-11	ELECT	10MF	20%	16V
C112	1-163-017-00	CERAMIC CHIP	0.0047MF	10%	50V
C113	1-163-006-11	CERAMIC CHIP	560PF	10%	50V
C114	1-164-232-11	CERAMIC CHIP	0.01MF		50V
C115	1-162-638-11	CERAMIC CHIP	1MF		16V
C116	1-124-225-00	ELECT	100MF	20%	6.3V
C117	1-124-225-00	ELECT	100MF	20%	6.3V
C118	1-126-176-11	ELECT	220MF	20%	6.3V
C124	1-124-589-11	ELECT	47MF	20%	10V
C125	1-163-009-11	CERAMIC CHIP	0.001MF	10%	50V
C126	1-126-157-11	ELECT	10MF	20%	16V
C127	1-163-007-11	CERAMIC CHIP	680PF	10%	50V
C128	1-163-077-00	CERAMIC CHIP	0.1MF	10%	25V
C129	1-126-176-11	ELECT	220MF	20%	6.3V
C130	1-164-157-11	CERAMIC CHIP	0.068MF	10%	25V
C131	1-162-638-11	CERAMIC CHIP	1MF		16V
C150	1-164-232-11	CERAMIC CHIP	0.01MF	10%	50V
C159	1-125-548-11	ELECT	0.1F		50V
C160	1-124-472-11	ELECT	470MF	20%	6.3V
C161	1-163-077-00	CERAMIC CHIP	0.1MF	10%	25V
C162	1-163-077-00	CERAMIC CHIP	0.1MF	10%	25V
C163	1-124-589-11	ELECT	47MF	20%	10V
C164	1-124-898-11	ELECT	4700MF	20%	16V
C165	1-124-225-00	ELECT	100MF	20%	6.3V
C166	1-163-077-00	CERAMIC CHIP	0.1MF	10%	25V
C167	1-163-105-00	CERAMIC CHIP	33PF	5%	50V
C168	1-163-105-00	CERAMIC CHIP	33PF	5%	50V
C169	1-163-037-11	CERAMIC CHIP	0.022MF	10%	25V
C170	1-124-589-11	ELECT	47MF	20%	10V
C171	1-163-077-00	CERAMIC CHIP	0.1MF	10%	25V
C172	1-124-246-00	ELECT	6.8MF	20%	35V
C175	1-163-059-00	CERAMIC CHIP	0.01MF	10%	50V
C176	1-163-059-00	CERAMIC CHIP	0.01MF	10%	50V
C177	1-163-059-00	CERAMIC CHIP	0.01MF	10%	50V
C190	1-124-225-00	ELECT	100MF	20%	6.3V
C191	1-163-038-00	CERAMIC CHIP	0.1MF		25V
C192	1-124-225-00	ELECT	100MF	20%	6.3V
C193	1-163-038-00	CERAMIC CHIP	0.1MF		25V
C195	1-163-038-00	CERAMIC CHIP	0.1MF		25V
C201	1-163-018-00	CERAMIC CHIP	0.0056MF	10%	50V
C202	1-163-117-00	CERAMIC CHIP	100PF	5%	50V

Ref.No	Part No.	Description			
C203	1-163-038-00	CERAMIC CHIP	0.1MF		25V
C204	1-163-035-00	CERAMIC CHIP	0.047MF		50V
C205	1-164-232-11	CERAMIC CHIP	0.01MF	10%	50V
C206	1-163-117-00	CERAMIC CHIP	100PF	5%	50V
C208	1-163-117-00	CERAMIC CHIP	100PF	5%	50V
C209	1-163-117-00	CERAMIC CHIP	100PF	5%	50V
C211	1-163-077-00	CERAMIC CHIP	0.1MF	10%	25V
C212	1-164-232-11	CERAMIC CHIP	0.01MF	10%	50V
C213	1-163-009-11	CERAMIC CHIP	0.001MF	10%	50V
C601	1-135-091-00	TANTAL CHIP	1MF	20%	16V
C602	1-135-149-21	TANTAL CHIP	2.2MF	20%	10V
C603	1-164-232-11	CERAMIC CHIP	0.01MF	10%	50V
C604	1-135-149-21	TANTAL CHIP	2.2MF	20%	10V
C605	1-164-232-11	CERAMIC CHIP	0.01MF	10%	50V
C606	1-135-149-21	TANTAL CHIP	2.2MF	20%	10V
C607	1-135-149-21	TANTAL CHIP	2.2MF	20%	10V
C608	1-164-232-11	CERAMIC CHIP	0.01MF	10%	50V
C609	1-126-154-11	ELECT	47MF	20%	6.3V
C610	1-124-257-00	ELECT	2.2MF	20%	50V
C611	1-163-117-00	CERAMIC CHIP	100PF	5%	50V
C612	1-163-117-00	CERAMIC CHIP	100PF	5%	50V
C613	1-163-077-00	CERAMIC CHIP	0.1MF	10%	25V
C614	1-163-077-00	CERAMIC CHIP	0.1MF	10%	25V
C615	1-164-004-11	CERAMIC CHIP	0.1MF	10%	25V
CN106	1-580-286-21	SOCKET, CONNECTOR 29P			
CN112	*1-561-533-00	SOCKET, CONNECTOR 12P (CONTROL UNIT)			
CN902	1-580-287-21	SOCKET, CONNECTOR 29P			
CNJ101	*1-562-152-11	HOUSING, CONNECTOR 7P			
CNJ102	*1-562-147-11	HOUSING, CONNECTOR 2P			
CNJ105	*1-562-147-11	HOUSING, CONNECTOR 2P			
CNJ107	*1-562-151-11	HOUSING, CONNECTOR 6P			
CNJ108	*1-562-152-31	HOUSING, CONNECTOR 7P			
CNJ109	*1-562-151-11	HOUSING, CONNECTOR 6P			
CNJ601	*1-562-149-11	HOUSING, CONNECTOR 4P			
CNJ602	*1-562-147-11	HOUSING, CONNECTOR 2P			
CNJ603	*1-562-151-11	HOUSING, CONNECTOR 6P			
CNJ604	*1-562-152-31	HOUSING, CONNECTOR 7P			
CNJ605	*1-562-151-11	HOUSING, CONNECTOR 6P			
CNJ901	*1-562-147-11	HOUSING, CONNECTOR 2P			
CNP101	1-506-472-11	PIN, CONNECTOR 7P			
CNP102	1-506-467-11	PIN, CONNECTOR 2P			
CNP104	1-506-470-11	PIN, CONNECTOR 5P			
CNP105	1-506-467-11	PIN, CONNECTOR 2P			
CNP107	1-506-471-11	PIN, CONNECTOR 6P			
CNP108	1-506-472-11	PIN, CONNECTOR 7P			
CNP109	1-506-471-11	PIN, CONNECTOR 6P			
CNP601	1-506-469-11	PIN, CONNECTOR 4P			
CNP602	1-506-467-11	PIN, CONNECTOR 2P			
CNP603	1-506-471-11	PIN, CONNECTOR 6P			
CNP604	1-506-472-11	PIN, CONNECTOR 7P			
CNP605	1-506-471-11	PIN, CONNECTOR 6P			
CNP901	1-506-481-11	PIN, CONNECTOR 2P			
D107	8-719-400-18	DIODE MA152WK			

Ref.No	Part No.	Description
D108	8-719-400-18	DIODE MA152WK
D109	8-719-400-18	DIODE MA152WK
D110	8-719-400-18	DIODE MA152WK
D111	8-719-400-18	DIODE MA152WK
D112	8-719-400-18	DIODE MA152WK
D113	8-719-400-18	DIODE MA152WK
D114	8-719-940-45	DIODE DWA010
D117	8-719-510-38	DIODE D1F10
D601	8-719-105-45	DIODE RD3.3M-B1
D602	8-719-200-02	(Up to 0505400)....DIODE 10E2
D602	8-719-510-38	(0505401 and later)....DIODE D1F10
D604	8-719-510-38	DIODE D1F10
D605	8-719-510-38	DIODE D1F10
D606	8-719-510-38	DIODE D1F10
EL901	1-808-962-11	DEVICE, EL
HRP901	1-543-564-11	HEAD, MAGNETIC (PB/ERASE)
IC101	8-759-008-79	IC MC14011BF
IC102	8-759-981-99	IC RC4560M
IC103	8-759-925-05	IC LM2903PS
IC106	8-759-230-04	IC TA7628HP
IC111	8-759-148-79	IC UPC2406HF
IC112	8-759-149-21	IC UPD75308GF-496-3B9
IC601	8-759-821-20	IC LB1672M
IC602	8-759-932-54	IC MC14066BF
IC603	8-759-925-80	IC SN74HC14NS
IC604	8-759-801-12	IC LA5523
J102	1-568-727-11	JACK, DC (DC IN 9V)
J103	1-566-891-21	JACK (EARPHONE)
JR601	1-216-296-00	METAL GLAZE 0 5% 1/8W
JR602	1-216-296-00	METAL GLAZE 0 5% 1/8W
JR603	1-216-296-00	METAL GLAZE 0 5% 1/8W
JR604	1-216-296-00	METAL GLAZE 0 5% 1/8W
JR605	1-216-296-00	METAL GLAZE 0 5% 1/8W
JR606	1-216-296-00	METAL GLAZE 0 5% 1/8W
JR607	1-216-296-00	METAL GLAZE 0 5% 1/8W
JR608	1-216-296-00	METAL GLAZE 0 5% 1/8W
JR609	1-216-296-00	METAL GLAZE 0 5% 1/8W
JR610	1-216-296-00	METAL GLAZE 0 5% 1/8W
JR611	1-216-296-00	METAL GLAZE 0 5% 1/8W
JR612	1-216-296-00	METAL GLAZE 0 5% 1/8W
JR613	1-216-296-00	METAL GLAZE 0 5% 1/8W
JR614	1-216-296-00	METAL GLAZE 0 5% 1/8W
JR615	1-216-296-00	METAL GLAZE 0 5% 1/8W
JR616	1-216-296-00	METAL GLAZE 0 5% 1/8W
JR617	1-216-296-00	METAL GLAZE 0 5% 1/8W
JR618	1-216-296-00	METAL GLAZE 0 5% 1/8W
JR619	1-216-296-00	METAL GLAZE 0 5% 1/8W
JR620	1-216-296-00	METAL GLAZE 0 5% 1/8W
JR621	1-216-296-00	METAL GLAZE 0 5% 1/8W
JR622	1-216-296-00	METAL GLAZE 0 5% 1/8W
JR623	1-216-296-00	METAL GLAZE 0 5% 1/8W
JR624	1-216-296-00	METAL GLAZE 0 5% 1/8W
JR625	1-216-296-00	METAL GLAZE 0 5% 1/8W
JR626	1-216-296-00	METAL GLAZE 0 5% 1/8W
JR627	1-216-296-00	METAL GLAZE 0 5% 1/8W
JR629	1-216-296-00	METAL GLAZE 0 5% 1/8W
JR630	1-216-296-00	METAL GLAZE 0 5% 1/8W
JR631	1-216-296-00	METAL GLAZE 0 5% 1/8W
JR632	1-216-296-00	METAL GLAZE 0 5% 1/8W
JR633	1-216-296-00	METAL GLAZE 0 5% 1/8W
JR635	1-216-296-00	METAL GLAZE 0 5% 1/8W
JR636	1-216-296-00	METAL GLAZE 0 5% 1/8W
JR637	1-216-296-00	METAL GLAZE 0 5% 1/8W

Ref.No	Part No.	Description
JR638	1-216-296-00	METAL GLAZE 0 5% 1/8W
JR639	1-216-296-00	METAL GLAZE 0 5% 1/8W
JR640	1-216-296-00	METAL GLAZE 0 5% 1/8W
JR641	1-216-296-00	METAL GLAZE 0 5% 1/8W
JR642	1-216-296-00	METAL GLAZE 0 5% 1/8W
JR643	1-216-296-00	METAL GLAZE 0 5% 1/8W
JR645	1-216-296-00	METAL GLAZE 0 5% 1/8W
JR646	1-216-296-00	METAL GLAZE 0 5% 1/8W
JR647	1-216-296-00	METAL GLAZE 0 5% 1/8W
JR648	1-216-296-00	METAL GLAZE 0 5% 1/8W
JR649	1-216-296-00	METAL GLAZE 0 5% 1/8W
JR650	1-216-296-00	METAL GLAZE 0 5% 1/8W
JR651	1-216-296-00	METAL GLAZE 0 5% 1/8W
JR652	1-216-296-00	METAL GLAZE 0 5% 1/8W
JR653	1-216-296-00	METAL GLAZE 0 5% 1/8W
JR654	1-216-296-00	METAL GLAZE 0 5% 1/8W
JR655	1-216-296-00	METAL GLAZE 0 5% 1/8W
JR656	1-216-296-00	METAL GLAZE 0 5% 1/8W
JR657	1-216-296-00	METAL GLAZE 0 5% 1/8W
JR658	1-216-296-00	METAL GLAZE 0 5% 1/8W
JR659	1-216-296-00	METAL GLAZE 0 5% 1/8W
JR660	1-216-296-00	METAL GLAZE 0 5% 1/8W
JR661	1-216-296-00	METAL GLAZE 0 5% 1/8W
JR662	1-216-296-00	METAL GLAZE 0 5% 1/8W
JR663	1-216-296-00	METAL GLAZE 0 5% 1/8W
JR664	1-216-296-00	METAL GLAZE 0 5% 1/8W
JR665	1-216-296-00	METAL GLAZE 0 5% 1/8W
JR666	1-216-296-00	METAL GLAZE 0 5% 1/8W
JW1	1-216-296-00	METAL GLAZE 0 5% 1/8W
JW2	1-216-296-00	METAL GLAZE 0 5% 1/8W
JW3	1-216-296-00	METAL GLAZE 0 5% 1/8W
JW4	1-216-296-00	METAL GLAZE 0 5% 1/8W
JW5	1-216-296-00	METAL GLAZE 0 5% 1/8W
JW6	1-216-296-00	METAL GLAZE 0 5% 1/8W
JW7	1-216-296-00	METAL GLAZE 0 5% 1/8W
JW8	1-216-296-00	METAL GLAZE 0 5% 1/8W
JW9	1-216-296-00	METAL GLAZE 0 5% 1/8W
JW10	1-216-296-00	METAL GLAZE 0 5% 1/8W
JW11	1-216-296-00	METAL GLAZE 0 5% 1/8W
JW12	1-216-296-00	METAL GLAZE 0 5% 1/8W
JW13	1-216-296-00	METAL GLAZE 0 5% 1/8W
M901	1-541-478-11	MOTOR (FWD)
M902	X-3362-206-1	MOTOR ASSY (F/R)
ND901	1-808-961-11	DISPLAY PANEL, LIQUID CRYSTAL
PH601	8-719-939-23	PHOTO REFLECTOR GP-2S09-C
PH602	8-719-939-23	PHOTO REFLECTOR GP-2S09-C
PM901	1-454-459-21	SOLENOID, PLUNGER (STOP)
PM902	1-454-459-21	SOLENOID, PLUNGER (FWD)
PM903	1-454-509-11	SOLENOID, PLUNGER (BREAK)
PS101	1-532-675-00	LINK, IC ICP-F38 1.5A
Q103	8-729-800-37	TRANSISTOR 2SD1048-X7
Q107	8-729-101-07	TRANSISTOR 2SB798-DL
Q111	8-729-901-01	TRANSISTOR DTC144EK
Q113	8-729-230-49	TRANSISTOR 2SC2712-YG
Q114	8-729-230-49	TRANSISTOR 2SC2712-YG
Q115	8-729-230-49	TRANSISTOR 2SC2712-YG
Q116	8-729-800-37	TRANSISTOR 2SD1048-X7
Q301	8-729-800-37	TRANSISTOR 2SD1048-X7
Q601	8-729-140-75	TRANSISTOR 2SD999-CLCK
Q602	8-729-900-53	TRANSISTOR DTC114EK
Q603	8-729-101-07	TRANSISTOR 2SB798-DL
Q604	8-729-140-75	TRANSISTOR 2SD999-CLCK

Note 1:
D602 differs by the set.
10E2 Part with lead
D1F10 Chip component

Note:
The components identified by mark Δ or dotted line with mark Δ are critical for safety. Replace only with part number specified.

Note:
Les composants identifiés par une marque Δ sont critiques pour la sécurité. Ne les remplacer que par une pièce portant le numéro spécifié.

Ref.No	Part No.	Description
Q605	8-729-101-07	TRANSISTOR 2SB798-DL
Q606	8-729-140-75	TRANSISTOR 2SD999-CLCK
Q607	8-729-901-46	TRANSISTOR DTA114YK
Q608	8-729-901-46	TRANSISTOR DTA114YK
Q609	8-729-901-46	TRANSISTOR DTA114YK
Q610	8-729-140-75	TRANSISTOR 2SD999-CLCK
Q611	8-729-140-75	TRANSISTOR 2SD999-CLCK
Q612	8-729-140-75	TRANSISTOR 2SD999-CLCK
Q613	8-729-900-53	TRANSISTOR DTC114EK
Q614	8-729-141-48	TRANSISTOR 2SB624-BV345
Q615	8-729-141-48	TRANSISTOR 2SB624-BV345
Q616	8-729-141-48	TRANSISTOR 2SB624-BV345
Q617	8-729-900-98	TRANSISTOR DTC143TK
Q618	8-729-140-75	TRANSISTOR 2SD999-CLCK
Q619	8-729-900-98	TRANSISTOR DTC143TK
RESISTOR		
R108	1-216-109-00	METAL GLAZE 330K 5% 1/10W
R109	1-216-073-00	METAL GLAZE 10K 5% 1/10W
R110	1-216-081-00	METAL GLAZE 22K 5% 1/10W
R111	1-216-081-00	METAL GLAZE 22K 5% 1/10W
R112	1-216-043-00	METAL GLAZE 560 5% 1/10W
R113	1-216-115-00	METAL GLAZE 560K 5% 1/10W
R114	1-216-049-00	METAL GLAZE 1K 5% 1/10W
R115	1-216-105-00	METAL GLAZE 220K 5% 1/10W
R116	1-216-057-00	METAL GLAZE 2.2K 5% 1/10W
R117	1-216-065-00	METAL GLAZE 4.7K 5% 1/10W
R118	1-216-053-00	METAL GLAZE 1.5K 5% 1/10W
R119	1-216-063-00	METAL GLAZE 3.9K 5% 1/10W
R122	1-216-057-00	METAL GLAZE 2.2K 5% 1/10W
R123	1-216-029-00	METAL GLAZE 150 5% 1/10W
R125	1-216-083-00	METAL GLAZE 27K 5% 1/10W
R126	1-216-105-00	METAL GLAZE 220K 5% 1/10W
R135	1-216-089-00	METAL GLAZE 47K 5% 1/10W
R136	1-216-065-00	METAL GLAZE 4.7K 5% 1/10W
R137	1-216-027-00	METAL GLAZE 120 5% 1/10W
R138	1-216-069-00	METAL GLAZE 6.8K 5% 1/10W
R139	1-216-037-00	METAL GLAZE 330 5% 1/10W
R140	1-216-097-00	METAL GLAZE 100K 5% 1/10W
R171	△ 1-215-861-00	METAL OXIDE 47 5% 1W F
R172	1-216-097-00	METAL GLAZE 100K 5% 1/10W
R173	1-216-065-00	METAL GLAZE 4.7K 5% 1/10W
R183	1-216-065-00	METAL GLAZE 4.7K 5% 1/10W
R184	1-216-065-00	METAL GLAZE 4.7K 5% 1/10W
R188	1-216-017-00	METAL GLAZE 47 5% 1/10W
R190	1-216-041-00	METAL GLAZE 470 5% 1/10W
R196	1-216-089-00	METAL GLAZE 47K 5% 1/10W
R197	1-216-089-00	METAL GLAZE 47K 5% 1/10W
R198	1-216-089-00	METAL GLAZE 47K 5% 1/10W
R202	1-216-049-00	METAL GLAZE 1K 5% 1/10W
R203	1-216-049-00	METAL GLAZE 1K 5% 1/10W
R204	1-216-049-00	METAL GLAZE 1K 5% 1/10W
R206	1-216-089-00	METAL GLAZE 47K 5% 1/10W
R207	1-216-089-00	METAL GLAZE 47K 5% 1/10W
R208	1-216-089-00	METAL GLAZE 47K 5% 1/10W
R209	1-216-089-00	METAL GLAZE 47K 5% 1/10W
R210	1-216-081-00	METAL GLAZE 22K 5% 1/10W
R211	1-216-089-00	METAL GLAZE 47K 5% 1/10W
R212	1-216-097-00	METAL GLAZE 100K 5% 1/10W
R213	1-216-080-00	METAL GLAZE 20K 5% 1/10W
R217	1-216-089-00	METAL GLAZE 47K 5% 1/10W
R219	1-216-023-00	METAL GLAZE 82 5% 1/10W
R220	1-216-073-00	METAL GLAZE 10K 5% 1/10W
R225	1-216-027-00	METAL GLAZE 120 5% 1/10W
R226	1-216-097-00	METAL GLAZE 100K 5% 1/10W
R227	1-216-065-00	METAL GLAZE 4.7K 5% 1/10W

Ref.No	Part No.	Description
R233	1-216-085-00	METAL GLAZE 33K 5% 1/10W
R234	1-216-073-00	METAL GLAZE 10K 5% 1/10W
R235	1-216-073-00	METAL GLAZE 10K 5% 1/10W
R236	1-216-073-00	METAL GLAZE 10K 5% 1/10W
R241	1-216-037-00	METAL GLAZE 330 5% 1/10W
R242	1-216-077-00	METAL GLAZE 15K 5% 1/10W
R301	1-216-049-00	METAL GLAZE 1K 5% 1/10W
R302	1-216-065-00	METAL GLAZE 4.7K 5% 1/10W
R303	1-216-097-00	METAL GLAZE 100K 5% 1/10W
R601	1-216-073-00	METAL GLAZE 10K 5% 1/10W
R602	1-216-049-00	METAL GLAZE 1K 5% 1/10W
R603	1-216-033-00	METAL GLAZE 220 5% 1/10W
R604	1-216-073-00	METAL GLAZE 10K 5% 1/10W
R605	1-216-035-00	METAL GLAZE 270 5% 1/10W
R612	1-216-055-00	METAL GLAZE 1.8K 5% 1/10W
R613	1-216-059-00	METAL GLAZE 2.7K 5% 1/10W
R615	1-216-053-00	METAL GLAZE 1.5K 5% 1/10W
R616	1-216-074-00	METAL GLAZE 11K 5% 1/10W
R618	1-216-089-00	METAL GLAZE 47K 5% 1/10W
R619	1-216-089-00	METAL GLAZE 47K 5% 1/10W
R620	1-216-073-00	METAL GLAZE 10K 5% 1/10W
R621	1-216-073-00	METAL GLAZE 10K 5% 1/10W
R622	1-216-041-00	METAL GLAZE 470 5% 1/10W
R623	1-216-073-00	METAL GLAZE 10K 5% 1/10W
R624	1-216-089-00	METAL GLAZE 47K 5% 1/10W
R625	1-216-089-00	METAL GLAZE 47K 5% 1/10W
R626	1-216-049-00	METAL GLAZE 1K 5% 1/10W
R627	1-216-049-00	METAL GLAZE 1K 5% 1/10W
R628	1-216-089-00	METAL GLAZE 47K 5% 1/10W
R629	1-216-049-00	METAL GLAZE 1K 5% 1/10W
R630	1-216-049-00	METAL GLAZE 1K 5% 1/10W
R631	1-216-037-00	METAL GLAZE 330 5% 1/10W
R632	1-216-097-00	METAL GLAZE 100K 5% 1/10W
R633	1-216-037-00	METAL GLAZE 330 5% 1/10W
R634	1-216-097-00	METAL GLAZE 100K 5% 1/10W
R635	1-216-037-00	METAL GLAZE 330 5% 1/10W
R636	1-216-025-00	METAL GLAZE 100 5% 1/10W
R637	1-216-031-00	METAL GLAZE 180 5% 1/10W
R638	1-216-089-00	METAL GLAZE 47K 5% 1/10W
R639	1-216-089-00	METAL GLAZE 47K 5% 1/10W
R640	1-216-073-00	METAL GLAZE 10K 5% 1/10W
R641	1-216-089-00	METAL GLAZE 47K 5% 1/10W
R642	1-216-073-00	METAL GLAZE 10K 5% 1/10W
R643	1-216-089-00	METAL GLAZE 47K 5% 1/10W
R644	1-216-069-00	METAL GLAZE 6.8K 5% 1/10W
R645	1-216-065-00	METAL GLAZE 4.7K 5% 1/10W
R646	1-216-037-00	METAL GLAZE 330 5% 1/10W
R647	1-216-037-00	METAL GLAZE 330 5% 1/10W
R648	1-216-037-00	METAL GLAZE 330 5% 1/10W
R649	1-216-035-00	METAL GLAZE 270 5% 1/10W
RV101	1-230-564-11	RES, VAR, SLIDE 10K (TONE)
RV102	1-230-564-11	RES, VAR, SLIDE 10K (VOLUME)
RV104	1-237-364-11	RES, VAR, SLIDE 100K (SPEED)
RV601	1-237-602-11	RES, ADJ, METAL GRAZE 1K
RV602	1-237-604-11	RES, ADJ, METAL GRAZE 4.7K
RV603	1-237-604-11	RES, ADJ, METAL GRAZE 4.7K
S101	1-572-251-11	SWITCH, SLIDE (STANDBY ON)
S102	1-572-251-11	SWITCH, SLIDE (TAPE SPEED)
S103	1-572-251-11	SWITCH, SLIDE (SPEED CONTROL)
S104	1-572-251-11	SWITCH, SLIDE (AUTO STOP)
S106	1-570-361-11	SWITCH, SLIDE (DIGITAL CORD) (REVERSE TIME)
S107	1-554-303-21	SWITCH, KEY BOARD (SCAN)
S109	1-554-303-21	SWITCH, KEY BOARD (● ERASE)
S110	1-554-303-21	SWITCH, KEY BOARD (RESET)
S111	1-554-303-21	SWITCH, KEY BOARD (STOP □)

<p>Note: The components identified by mark △ or dotted line with mark △ are critical for safety. Replace only with part number specified.</p>	<p>Note: Les composants identifiés par une marque △ sont critiques pour la sécurité. Ne les remplacer que par une pièce portant le numéro spécifié.</p>
--	---

Ref.No	Part No.	Description
S112	1-554-303-21	SWITCH, KEY BOARD (LISTEN ▷)
S113	1-554-303-21	SWITCH, KEY BOARD (REW <◀)
S114	1-554-303-21	SWITCH, KEY BOARD (FF ▷▷)
S601	1-572-248-11	SWITCH, LEAF (CAS DET)
S602	1-571-281-11	SWITCH, LEAF (TAB DET)
S603	1-572-248-11	SWITCH, LEAF (MC DET)
SP901	1-544-324-11	SPEAKER
T102	1-406-342-11	TRANSFORMER, OSC
THP601	1-809-132-11	THERMISTOR (POSITIVE)
THP602	1-809-133-11	THERMISTOR (POSITIVE)
X101	1-577-273-11	OSCILLATOR, CERAMIC 4.19MHz

ACCESSORIES & PACKING MATERIALS

- △ 1-465-393-11 (US, CND)...ADAPTOR, AC
- △ 1-465-428-11 (UK)...ADAPTOR, AC
- △ 1-465-429-11 (AEP, E)...ADAPTOR, AC
- 3-751-618-11 (EXCEPT FOR US)...MANUAL, INSTRUCTION (ENGLISH, FRENCH, GERMAN, SPANISH)
- 3-751-618-21 (US)...MANUAL, INSTRUCTION (ENGLISH)
- * 3-359-174-01 CUSHION (L)
- * 3-359-175-01 CUSHION (R)
- * 3-359-178-01 INDIVIDUAL CARTON

<p>Note: The components identified by mark △ or dotted line with mark △ are critical for safety. Replace only with part number specified.</p>	<p>Note: Les composants identifiés par une marque △ sont critiques pour la sécurité. Ne les remplacer que par une pièce portant le numéro spécifié.</p>
---	---

BM-77

SONY® SERVICE MANUAL

US Model
Canadian Model
AEP Model
UK Model
E Model

SUPPLEMENT-1

File this supplement with the service manual.

Subject : Change of LCD

Except for Canadian model :
Serial No. 23, 949 and later
Canadian model :
Serial No. A23, 949 and later

Liquid crystal display has been changed.
The back light (ND901) and back light drive circuit deleted
and also, mechanism parts are changed.

 : changed portion.
PRINTED WIRING BOARDS
Page 30 (Location : B-12)

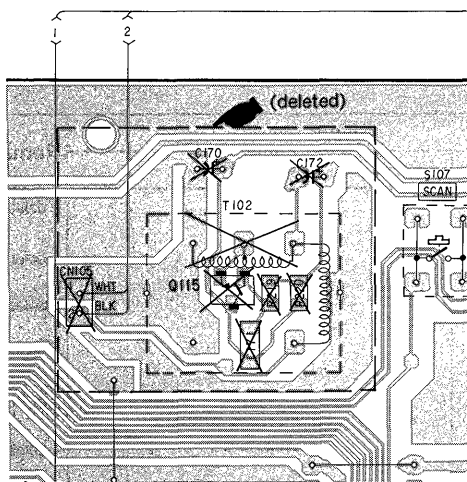

Page 30, 31 (Location : B-20)

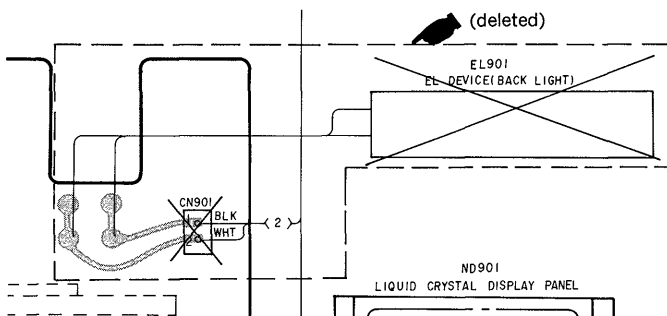

SCHEMATIC DIAGRAM
Page 35 (Location : H-14)

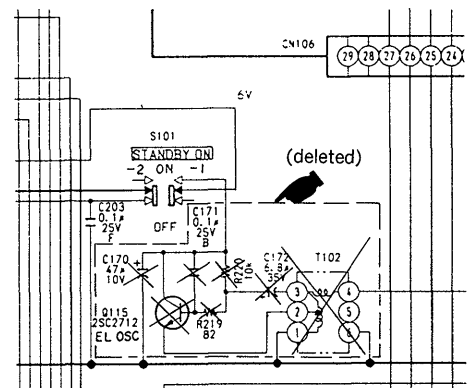

Page 35 (Location : E-18)

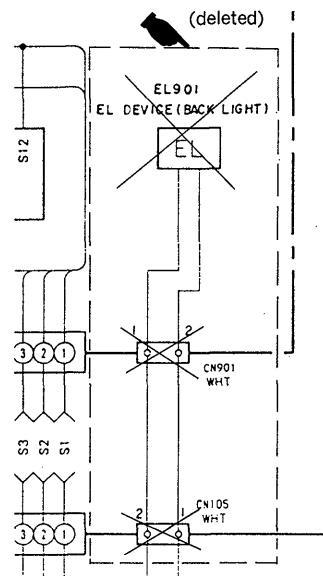

EXPLODED VIEWS

Page 37

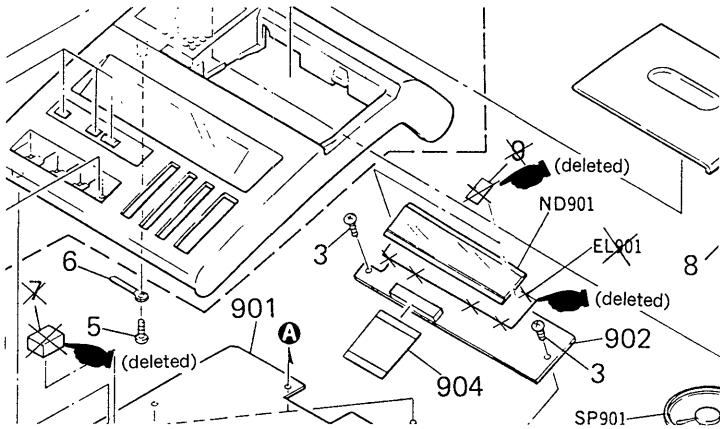

Page 38

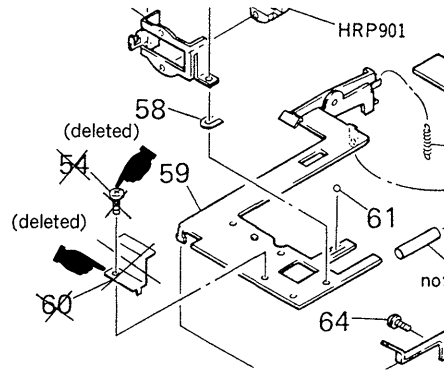

Ref. No.	Part No.	Description
* 7	3-323-675-01	PLATE, SHIELD (deleted)
9	9-911-838-XX	CUSHION, MAGNET (deleted)
EL901	1-808-962-11	DEVICE, EL (deleted)
ND901	1-808-961-21	DISPLAY PANEL, LIQUID CRYSTAL (changed)

Ref. No.	Part No.	Description
* 60	3-359-143-01	PLATE, SHIELD (deleted)

ELECTRICAL PARTS LIST

Page	Ref. No.	Former		New		Remark
		Part No.	Description	Part No.	Description	
40	C170	1-124-589-11	ELECT 47uF 20% 10V	---	---	deleted
	C171	1-163-077-00	CERAMIC CHIP 0.1uF 10% 25V	---	---	deleted
	C172	1-124-246-00	ELECT 6.8uF 20% 35V	---	---	deleted
	CNJ105	*1-562-147-11	HOUSING, CONNECTOR 2P	---	---	deleted
	CNJ901	*1-562-147-11	HOUSING, CONNECTOR 2P	---	---	deleted
	CNP105	*1-506-467-11	PIN, CONNECTOR 2P	---	---	deleted
	CNP901	*1-506-481-11	PIN, CONNECTOR 2P	---	---	deleted
41	EL901	1-808-962-11	DEVICE, EL	---	---	deleted
	ND901	1-808-961-11	DISPLAY PANEL, LIQUID CRYSTAL	1-808-961-21	DISPLAY PANEL, LIQUID CRYSTAL	changed
	Q115	8-729-230-49	TRANSISTOR 2SC2712-YG	---	---	deleted
42	R219	1-216-023-00	METAL GLAZE 82 5% 1/10W	---	---	deleted
	R220	1-216-073-00	METAL GLAZE 10K 5% 1/10W	---	---	deleted
43	T102	1-406-342-11	TRANSFORMER, OSC	---	---	deleted

• Items marked "*" are not stocked since they are seldom required for routine service. Some delay should be anticipated when ordering these items.