

C-357

SERVICE MANUAL

Ver 1.0 1999.02

US Model
Canadian Model
AEP Model



SPECIFICATIONS

General

Type: Condenser microphone
Microphone output connector: XLR-3-12C type
Stand screw: PF 1/2 screw
Dimensions: Approx. 40 x 213 mm (diameter x length) (1 5/8 x 8 1/2 in.)
Mass: Approx. 330 g (11.7 oz.) including battery
Supplied accessories: Wind screen (1)
Microphone holder (PF 1/2 screw) (1)
Microphone cord (5 m, 16 feet long) (1)
Carrying pouch (1)

Performance

Frequency response: 20 – 20,000 Hz
Directivity: Unidirectional/omni-directional (switchable)
Output impedance: 150 ohm ± 20% balanced (unbalanced with supplied microphone cord)
Sensitivity: Open circuit output level ^{*1}: -41 ± 3 dB
Power requirements: battery: R6 (size AA) x 1
Normal operating voltage: 1.5 V
Minimum operating voltage: Approx. 1 V
Battery life: Approx. 140 hours with Sony R6P (SR) battery
External Power: DC 48 V phantom power
Noise: Inherent noise ^{*2}: Less than 24 dB_{SPL}
Wind noise ^{*3} (with wind screen): Less than 50 dB_{SPL}
Induction noise from external magnetic field ^{*4}: Less than 5 dB_{SPL}
Maximum sound pressure level ^{*5}: More than 126 dB_{SPL}
Dynamic range: Approx. 102 dB
Operating temperature range: 0°C to 40°C (32°F to 104°F)
Storage temperature range: -20°C to 60°C (-4°F to 140°F)

*1 0 dB = 1 V/Pa, 1,000 Hz (1 Pa = 94 dB_{SPL}) Recommended load impedance: More than 3 kΩ
*2 0 dB_{SPL} = 2 x 10⁻⁵ Pa
*3 Converted from average of noise output level into fixed sound pressure input level when 2 m/sec wind is blowing from all directions to the microphone.
*4 The maximum level of noise induced in the microphone placed in a 50 Hz 1 x 10⁻⁷ T alternating magnetic field that is converted to an equivalent input sound pressure.
*5 Input level that causes 1% wavy distortion when the output signal of the microphone is 1,000 Hz.

Design and specifications are subject to change without notice.

Frequency Response Réponse en fréquence Respuesta en frecuencia

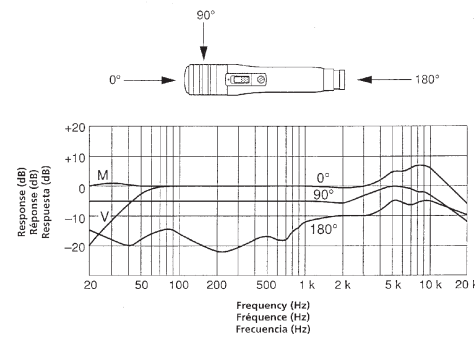

Directivity Directivité Directividad

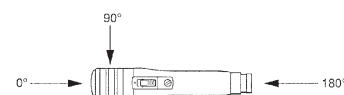
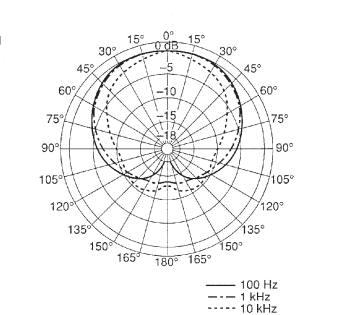

SECTION 1 GENERAL

This section is extracted from instruction manual.

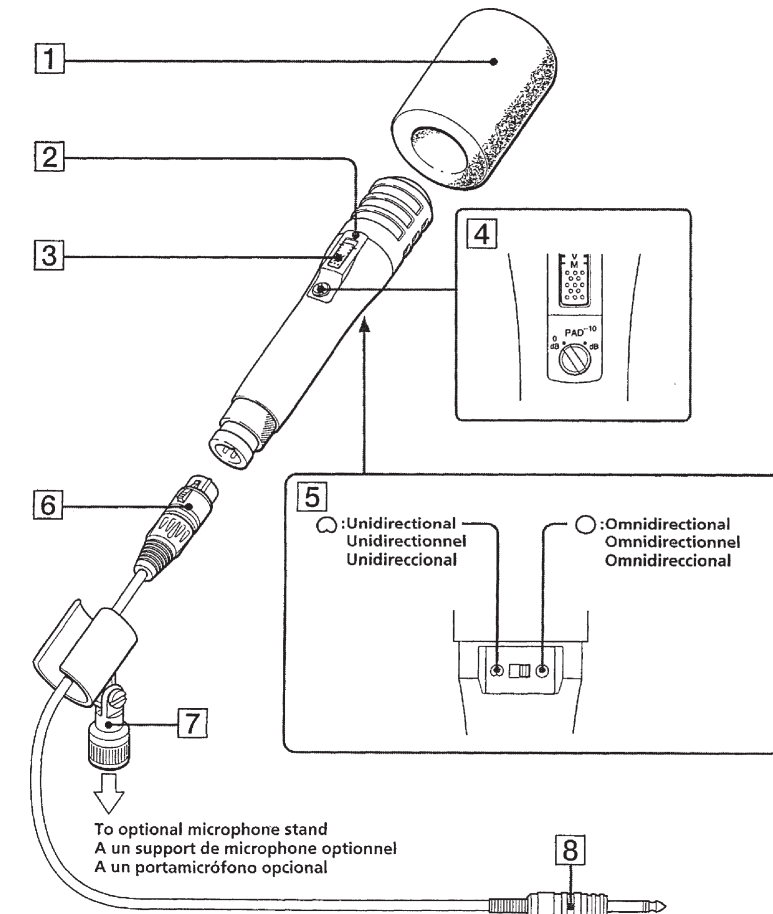

1 Wind screen

Attach to reduce hollow noise caused by the direct exposure to direct wind or breath.

2 Battery-check indicator

When you set the power/low-cut switch to on (the V or M position), the battery-check indicator flashes momentarily. This is normal and tells you whether the battery still has a charge. When the battery becomes discharged, the indicator lights dimly or does not light at all.

3 Power/low-cut switch

OFF	Turns the power off.
V	Clarifies human voice. Lowers low pitch noise of wind or vibration.
M	Catches natural wide pitch sound from low to high.

4 PAD switch

The sound received from a near source of high sound pressure may cause distortion. The PAD switch allows you to reduce the distortion by lowering the input level at the microphone's head amp.

0 dB: Normally use this position.

10 dB: Use this position when receiving on-microphone* sound from a source such as a piano, trumpet, etc., allowing you to reduce any distortion due to overload of the microphone's head amp.

* A way of receiving a sound by placing the microphone close to the sound source. It allows you to exclude peripheral noises, resulting in a clear sound of the desired source.

5 Directivity switch

This switch appears when you pull off the grip. See "Installing the battery."

6 Connector

7 Microphone holder

You can connect this to a microphone stand (PF 1/2) (optional).

8 Standard plug

Connect to the MIC jack of your recording equipment (DAT, Mixer, etc.).

Notes on chip component replacement

- Never reuse a disconnected chip component.
- Notice that the minus side of a tantalum capacitor may be damaged by heat.



CONDENSER MICROPHONE

SONY®

SECTION 2 DISASSEMBLY

Note : Follow the disassembly procedure in the numerical order given.

2-1. CASE ASSY, MICROPHONE

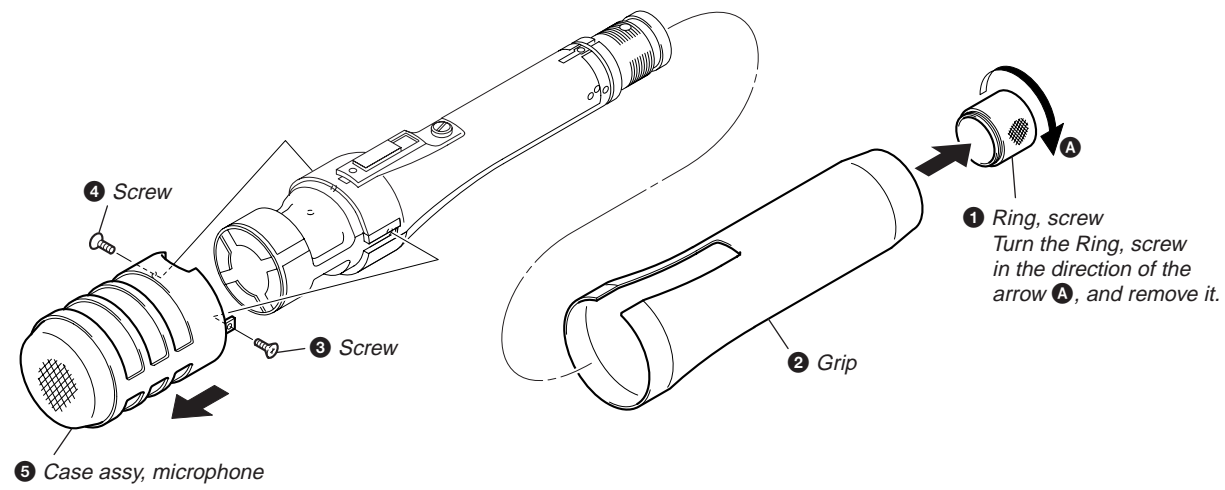

2-3. AMP BOARD

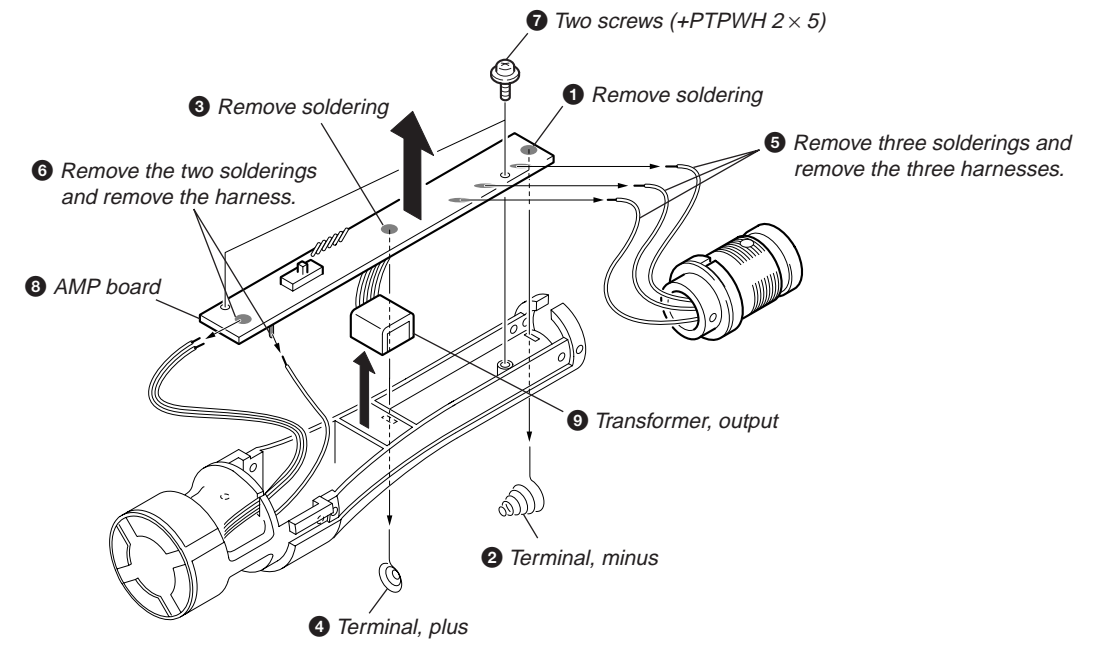

2-2. CHASSIS, "SLEEVE, CONNECTOR"

Note:

To re-attach it, turn the PAD knob first in the direction of the arrow and attach it.

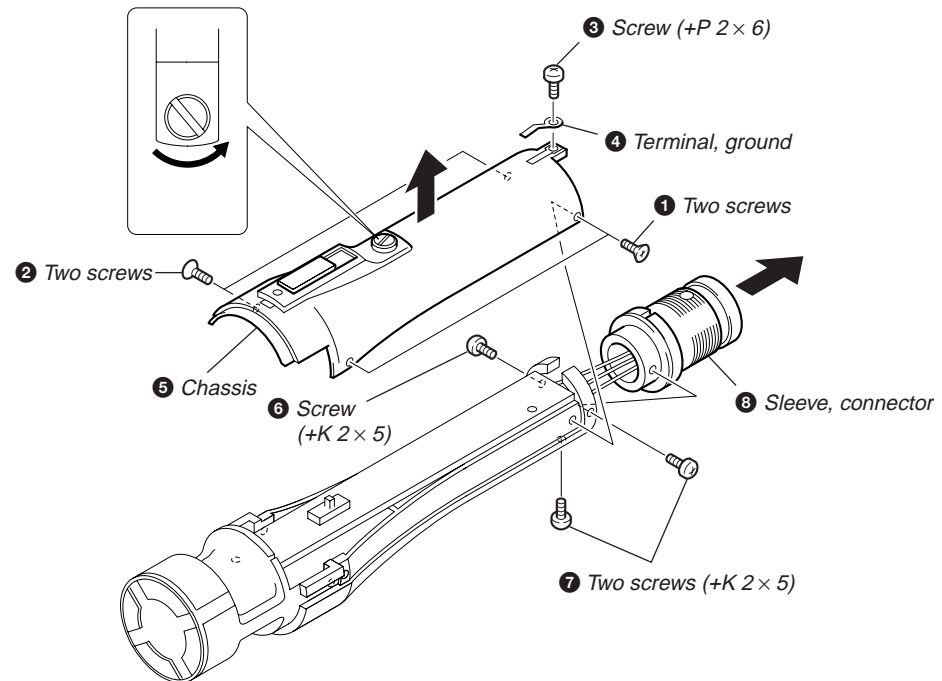

SECTION 3
DIAGRAMS

3-1. PRINTED WIRING BOARD

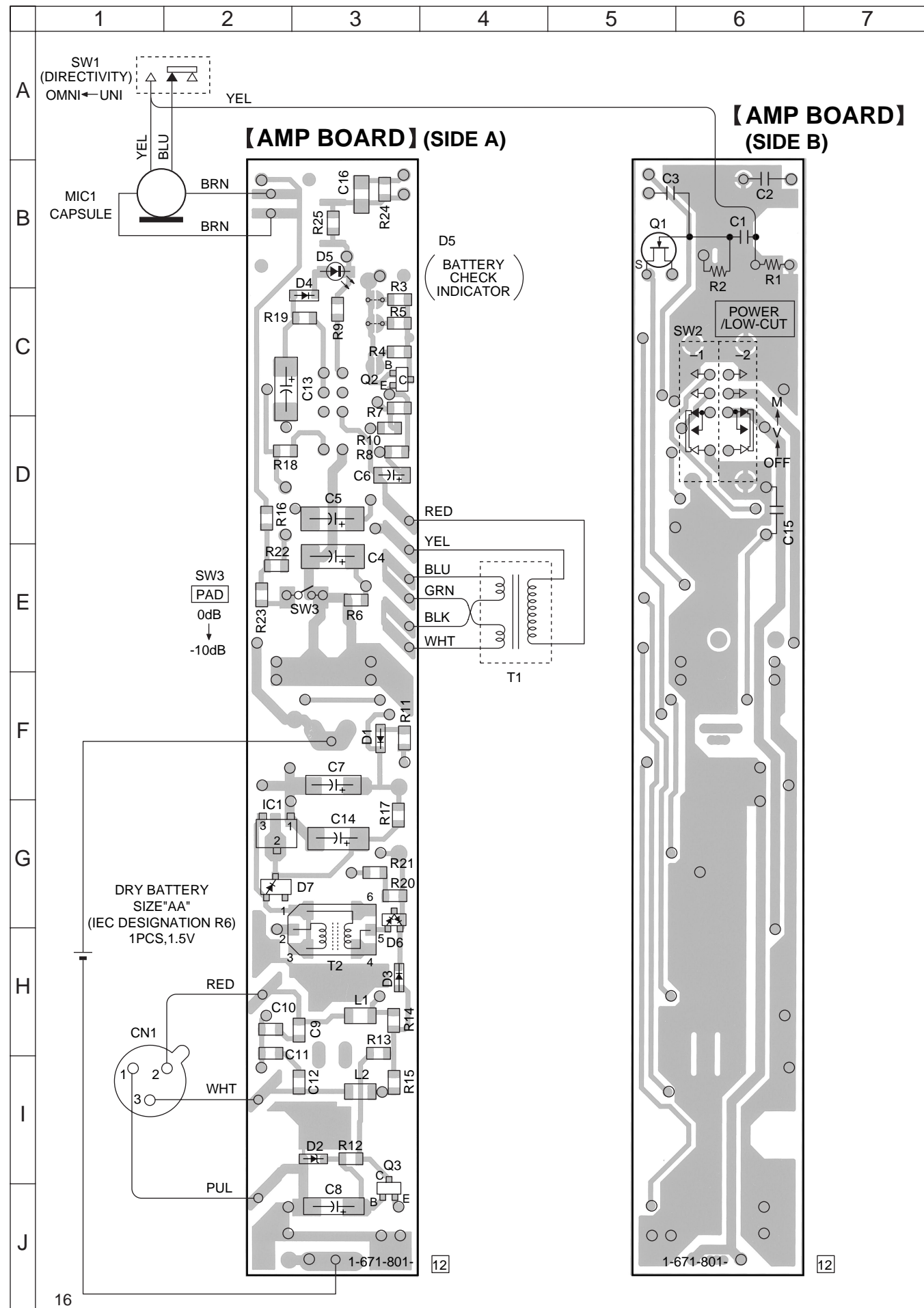

3-2. SCHAMITIC DIAGRAM

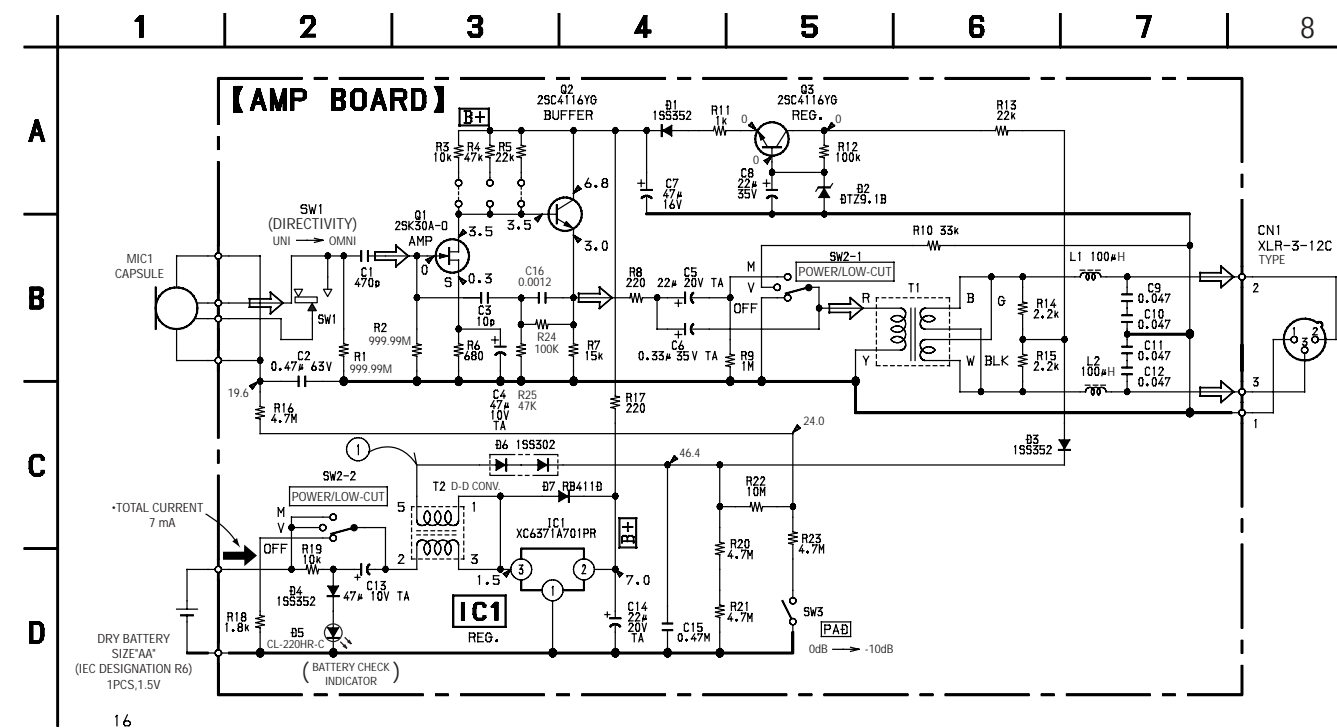

• Waveform

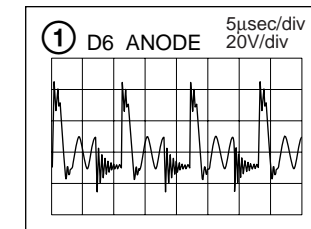

• Semiconductor Location

Ref. No.	Location
D1	F-3
D2	I-3
D3	H-3
D4	B-3
D5	B-3
D6	G-3
D7	G-2
IC1	G-2
Q1	B-5
Q2	C-3
Q3	I-3

Note on Printed Wiring Board:

- : parts extracted from the component side.
- : Through hole.
- ▨ : Pattern from the side which enables seeing.

Caution:
 Pattern face side: Parts on the pattern face side seen from the pattern face are indicated.
 Parts face side: Parts on the parts face side seen from the parts face are indicated.

Note on Schematic Diagram:

- All capacitors are in µF unless otherwise noted. pF: µF 50 WV or less are not indicated except for electrolytics and tantalums.
- All resistors are in Ω and 1/4 W or less unless otherwise specified.
- % : indicates tolerance.
- : panel designation.
- B+ : B+ Line.
- Power voltage is dc 1.5 V and fed with regulated dc power supply from battery terminal.
- Voltages and waveforms are dc with respect to ground under no-signal (detuned) conditions.
- Voltages are taken with a VOM (Input impedance 10 MΩ). Voltage variations may be noted due to normal production tolerances.
- Waveforms are taken with an oscilloscope. Voltage variations may be noted due to normal production tolerances.
- Circled numbers refer to waveforms.
- Signal path.
- ⇨ : MIC

SECTION 4 EXPLODED VIEWS

NOTE:

- XX, -X mean standardized parts, so they may have some differences from the original one.
- Items marked "*" are not stocked since they are seldom required for routine service. Some delay should be anticipated when ordering these items.

- The mechanical parts with no reference number in the exploded views are not supplied.

When indicating parts by reference number, please include the board name.

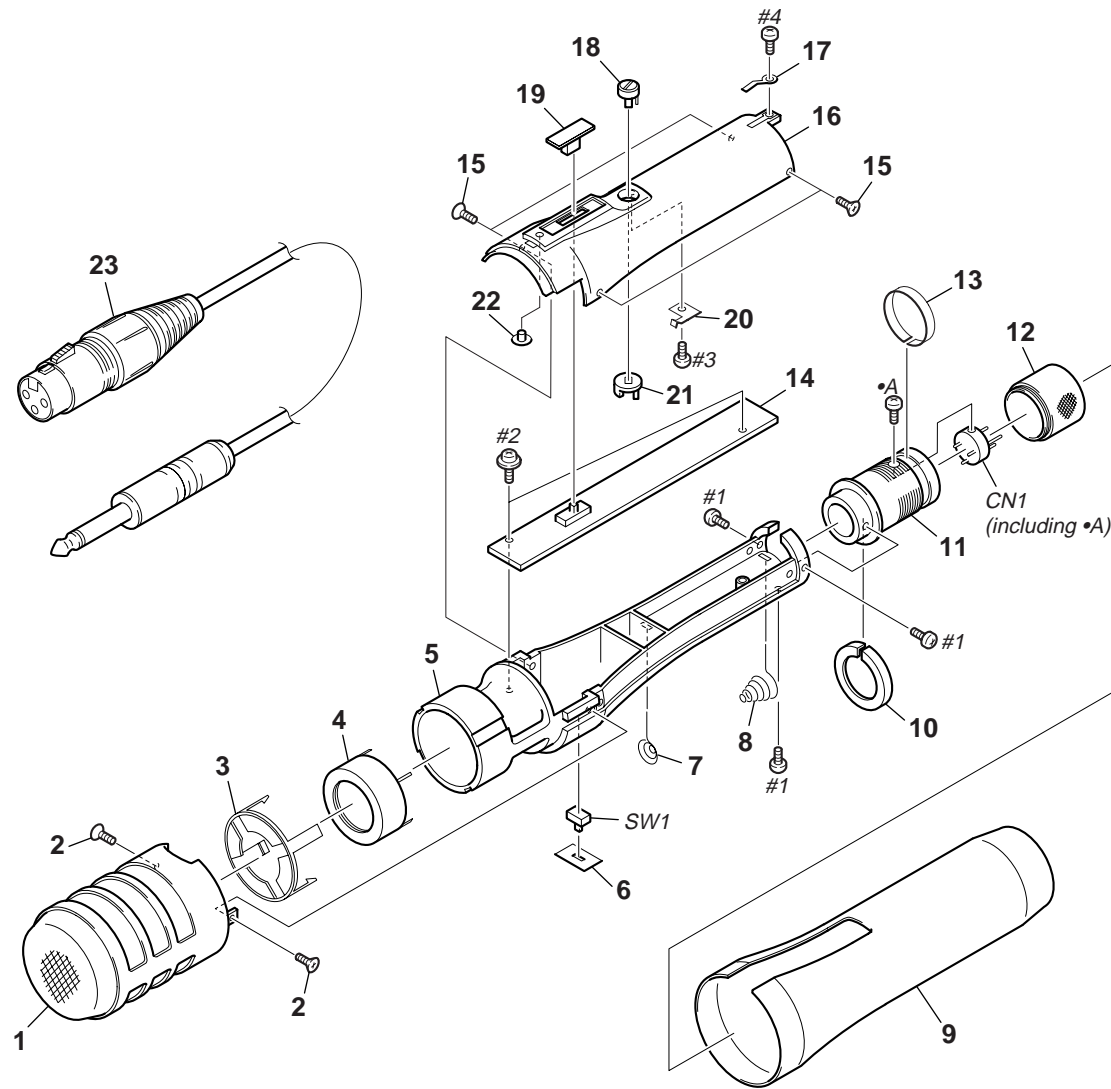

Ref. No.	Part No.	Description	Remarks	Ref. No.	Part No.	Description	Remarks
1	X-2542-164-1	CASE ASSY, MICROPHONE		* 16	2-545-572-01	CHASSIS	
2	3-736-363-11	TAPPING		* 17	2-545-613-01	TERMINAL, GROUND	
* 3	2-545-579-01	STOPPER, CAPSULE		18	2-545-581-01	KNOB (UPPER), PAD	
4	A-4540-552-A	CAPSULE ASSY		19	2-545-575-01	KNOB, POWER (POWER/LOW-CUT)	
* 5	2-545-573-01	FRAME		* 20	2-545-582-01	SPRING, PAD	
* 6	2-545-580-01	PANEL, BLIND		21	2-545-597-01	KNOB (LOWER), PAD	
7	2-544-797-01	TERMINAL, PLUS		22	2-545-594-01	COVER, LED	
8	2-544-798-01	TERMINAL, MINUS		23	1-696-448-11	CORD, MICROPHONE (DIA.5) (4 CORE)	
9	2-545-576-01	GRIP		CN1	1-563-175-61	CANNON XLR3-14 PIN INSERT	
10	2-545-578-01	JOINT		SW1	1-552-190-00	SWITCH, SLIDE (PAD)	
* 11	2-545-574-01	SLEEVE, CONNECTOR		#1	7-627-452-38	SCREW,PRECISION +K 2 × 5	
* 12	2-545-577-01	RING, SCREW		#2	7-685-103-19	+ PTPWH (2 × 5)	
13	2-545-598-01	LABEL, MODEL NUMBER		#3	7-627-551-18	SCREW,PRECISION +P 1.4 × 2	
* 14	A-4542-563-A	AMP BOARD, COMPLETE		#4	7-627-553-68	SCREW,PRECISION +P 2 × 6	
15	3-736-363-21	TAPPING					

C-357

AMP

NOTE:

- Due to standardization, replacements in the parts list may be different from the parts specified in the diagrams or the components used on the set.
- XX, -X mean standardized parts, so they may have some difference from the original one.
- Items marked "*" are not stocked since they are seldom required for routine service. Some delay should be anticipated when ordering these items.

Ref. No.	Part No.	Description	Remarks
*	A-4542-563-A	AMP BOARD, COMPLETE *****	
		< CAPACITOR >	
C1	1-130-467-00	MYLAR 470PF 5% 50V	
C2	1-130-776-00	MYLAR 0.47uF 10% 63V	
C3	1-107-202-00	MICA 10PF 5% 500V	
C4	1-113-642-11	TANTAL. CHIP 47uF 20% 10V	
C5	1-113-981-11	TANTAL. CHIP 22uF 20% 20V	
C6	1-135-073-00	TANTALUM CHIP 0.33uF 10% 35V	
C7	1-126-204-11	ELECT CHIP 47uF 20% 16V	
C8	1-126-400-11	ELECT CHIP 22uF 20% 35V	
C9	1-104-760-11	CERAMIC CHIP 0.047uF 10% 50V	
C10	1-104-760-11	CERAMIC CHIP 0.047uF 10% 50V	
C11	1-104-760-11	CERAMIC CHIP 0.047uF 10% 50V	
C12	1-104-760-11	CERAMIC CHIP 0.047uF 10% 50V	
C13	1-113-642-11	TANTAL. CHIP 47uF 20% 10V	
C14	1-113-981-11	TANTAL. CHIP 22uF 20% 20V	
C15	1-130-776-00	MYLAR 0.47uF 10% 63V	
C16	1-104-540-11	FILM CHIP 0.0012uF 5% 50V	
		< DIODE >	
D1	8-719-016-74	DIODE 1SS352	
D2	8-719-977-22	DIODE DTZ9.1	
D3	8-719-016-74	DIODE 1SS352	
D4	8-719-016-74	DIODE 1SS352	
D5	8-719-052-72	LED CL-220HR-C (BATTERY CHECK INDICATOR)	
D6	8-719-820-41	DIODE 1SS302	
D7	8-719-975-40	DIODE RB411D	
		< IC >	
IC1	8-759-564-83	IC XC6371A701PR	
		< COIL >	
L1	1-412-963-11	INDUCTOR 100uH	
L2	1-412-963-11	INDUCTOR 100uH	
		< TRANSISTOR >	
Q1	8-729-203-02	TRANSISTOR 2SK30A-O	
Q2	8-729-230-63	TRANSISTOR 2SC4116-YG	
Q3	8-729-230-63	TRANSISTOR 2SC4116-YG	
		< RESISTOR >	
R1	1-215-065-00	METAL OXIDE 999.99M 20% 1/8W	
R2	1-215-065-00	METAL OXIDE 999.99M 20% 1/8W	
R3	1-216-073-00	METAL CHIP 10K 5% 1/10W	

SECTION 5 ELECTRICAL PARTS LIST

CAPACITORS:

uF: μF

RESISTORS

All resistors are in ohms.

METAL: metal-film resistor

METAL OXIDE: Metal Oxide-film resistor

F: nonflammable

COILS

uH: μH

SEMICONDUCTORS

In each case, u: μ, for example:

uA...: μA... , uPA... , μPA... ,

uPB... , μPB... , uPC... , μPC... ,

uPD... , μPD...

When indicating parts by reference number, please include the board name.

Ref. No.	Part No.	Description	Remarks
R4	1-216-089-91	RES,CHIP 47K 5%	1/10W
R5	1-216-081-00	METAL CHIP 22K 5%	1/10W
R6	1-216-045-00	METAL CHIP 680 5%	1/10W
R7	1-216-077-00	METAL CHIP 15K 5%	1/10W
R8	1-216-033-00	METAL CHIP 220 5%	1/10W
R9	1-216-121-91	RES,CHIP 1M 5%	1/10W
R10	1-216-085-00	METAL CHIP 33K 5%	1/10W
R11	1-216-049-91	RES,CHIP 1K 5%	1/10W
R12	1-216-097-91	RES,CHIP 100K 5%	1/10W
R13	1-216-081-00	METAL CHIP 22K 5%	1/10W
R14	1-216-057-00	METAL CHIP 2.2K 5%	1/10W
R15	1-216-057-00	METAL CHIP 2.2K 5%	1/10W
R16	1-208-291-11	RES,CHIP 4.7M 5%	1/10W
R17	1-216-033-00	METAL CHIP 220 5%	1/10W
R18	1-216-055-00	METAL CHIP 1.8K 5%	1/10W
R19	1-216-073-00	METAL CHIP 10K 5%	1/10W
R20	1-208-291-11	RES,CHIP 4.7M 5%	1/10W
R21	1-208-291-11	RES,CHIP 4.7M 5%	1/10W
R22	1-218-179-11	RES,CHIP 10M 5%	1/10W
R23	1-208-291-11	RES,CHIP 4.7M 5%	1/10W
R24	1-216-097-91	RES,CHIP 100K 5%	1/10W
R25	1-216-089-91	RES,CHIP 47K 5%	1/10W
		< SWITCH >	
SW2	1-570-056-11	SWITCH, SLIDE (POWER/LOW-CUT)	
SW3	1-762-742-31	SWITCH, DETECTION (SMALL TYPE) (PAD)	
		< TRANSFORMER >	
T1	1-431-068-11	TRANSFORMER, OUTPUT	
T2	1-429-721-21	TRANSFORMER, DC-DC CONVERTER	

		MISCELLANEOUS	

CN1	1-563-175-61	CANNON XLR3-14 PIN INSERT	
SW1	1-552-190-00	SWITCH, SLIDE (DIRECTIVITY)	

		ACCESSORIES & PACKING MATERIALS	

	1-696-448-11	CORD, MICROPHONE (DIA.5) (4CORE)	
	2-100-951-04	ADAPTOR, SCREW, STAND (SAD-34) (AEP)	
	2-100-952-00	ADAPTOR, SCREW, STAND (SAD-35) (AEP)	
	2-545-055-01	SCREEN, WINDOW	
	2-545-148-01	PORCH, CARRYING	
	3-865-087-11	MANUAL, INSTRUCTION (GERMAN, DUTCH, ITALIAN) (AEP)	
	3-865-087-21	MANUAL, INSTRUCTION (ENGLISH, FRENCH, SPANISH)	
	A-4540-435-A	HOLDER ASSY	

Sony Corporation

Personal A&V Products Company

9-924-970-11

99B1660-1
Printed in Japan ©1999.2
Published by Quality Engineering Dept.
(Shinagawa)