

CDP-215/315

SERVICE MANUAL

US Model
AEP Model
CDP-215/315

E Model
Australian Model
CDP-315

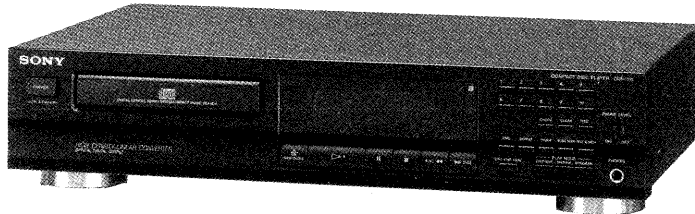

Photo: CDP-315 AEP model

Model Name Using Similar Mechanism	CDP-297/397
Tape Transport Mechanism Type	CDM14C-5DB10
Optical Pickup Block Type	BU-5BD10

SPECIFICATIONS

Compact disc player

Laser	Semiconductor laser ($\lambda = 780 \text{ nm}$)
Wavelength	780 – 790 nm
Frequency response	2 Hz to 20 kHz $\pm 0.5 \text{ dB}$
Signal-to-noise ratio	More than 100 dB
Dynamic range	More than 98 dB
Harmonic distortion	Less than 0.0045%
Channel separation	More than 95 dB

Outputs

LINE OUT (phono jacks)	Output level 2 V (at 50 kilohms) Load impedance over 10 kilohms
DIGITAL OUT (optical) (only for CDP-315)	(Optical output connector) Wavelength 660 nm Output level -18 dBm
PHONES (stereo phone jack)	Output level max. 10 mW Load impedance 32 ohms

General

Power requirements	AEP, Germany models : 220 – 230 V AC, 50/60 Hz US model : 120 V, 60 Hz Australian models : 240 V AC, 50 Hz For other countries: 110-120/220-240 V AC, adjustable with the voltage selector, 50/60 Hz
Power consumption	10 W

Dimensions (approx., including projections)	430 x 100 x 295 mm (w/h/d) (17 x 4 x 11 ⁵ / ₈ inches)
Mass (approx.)	3.2 kg (7 lbs 1 oz)

Remote commander (only for CDP-315)

Remote control system	Infrared control
Power requirements	3 VDC with two R6 (size AA) batteries

Dimensions (approx., including projections)	44 x 21 x 185 mm (w/h/d) (1 ³ / ₄ x ⁷ / ₈ x 7 ³ / ₈ inches)
Mass (approx.)	100 g (4 oz)

Supplied accessories

Audio cord	(1) (2 phono plugs – 2 phono plugs)
Remote commander (only for CDP-315)	(1)
Sony SUM-3 (NS) batteries (only for CDP-315)	(2)

Design and specifications are subject to change without notice.

COMPACT DISC PLAYER
SONY®

SAFETY CHECK-OUT

After correcting the original service problem, perform the following safety check before releasing the set to the customer:

Check the antenna terminals, metal trim, "metallized" knobs, screws, and all other exposed metal parts for AC leakage. Check leakage as described below.

LEAKAGE TEST

The AC leakage from any exposed metal part to earth ground and from all exposed metal parts to any exposed metal part having a return to chassis, must not exceed 0.5 mA (500 microamperes). Leakage current can be measured by any one of three methods.

1. A commercial leakage tester, such as the Simpson 229 or RCA WT-540A. Follow the manufacturers' instructions to use these instruments.
2. A battery-operated AC milliammeter. The Data Precision 245 digital multimeter is suitable for this job.
3. Measuring the voltage drop across a resistor by means of a VOM or battery-operated AC voltmeter. The "limit" indication is 0.75 V, so analog meters must have an accurate low-voltage scale. The Simpson 250 and Sanwa SH-63Trd are examples of a passive VOM that is suitable. Nearly all battery operated digital multimeters that have a 2 V AC range are suitable. (See Fig. A)

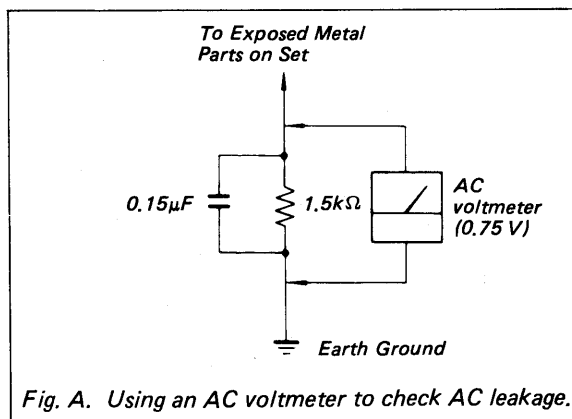

SAFETY-RELATED COMPONENT WARNING!!

COMPONENTS IDENTIFIED BY MARK OR DOTTED LINE WITH MARK ON THE SCHEMATIC DIAGRAMS AND IN THE PARTS LIST ARE CRITICAL TO SAFE OPERATION. REPLACE THESE COMPONENTS WITH SONY PARTS WHOSE PART NUMBERS APPEAR AS SHOWN IN THIS MANUAL OR IN SUPPLEMENTS PUBLISHED BY SONY.

TABLE OF CONTENTS

<i>Section</i>	<i>Title</i>	<i>Page</i>
1. GENERAL	4
2. DISASSEMBLY	5
3. ELECTRICAL BLOCK CHECKING	6
4. DIAGRAMS		
4-1. IC Pin Description		
•IC101 CXD2515Q	8
•IC201 CXP82316-037Q	10
4-2. Block Diagram	12
4-3. Semiconductor Lead Layouts	15
4-4. Printed Wiring Board	16
4-5. Schematic Diagram	19
5. EXPLODED VIEWS		
5-1. Cabinet Section	23
5-2. CD Mechanism Section (CDM14C-5BD10)	25
5-3. Optical Pick-up Block (BU-5BD10)	26
6. ELECTRICAL PARTS LIST	27

MODEL IDENTIFICATION

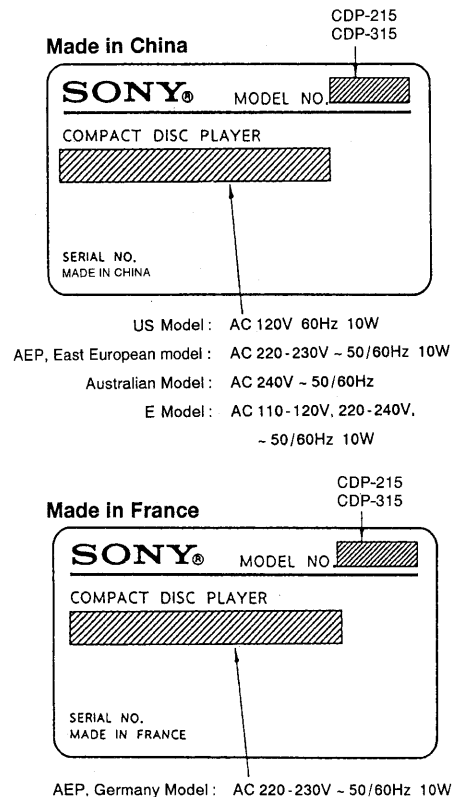

SERVICING NOTES

NOTES ON HANDLING THE OPTICAL PICK-UP BLOCK OR BASE UNIT

The laser diode in the optical pick-up block may suffer electrostatic breakdown because of the potential difference generated by the charged electrostatic load, etc. on clothing and the human body.

During repair, pay attention to electrostatic breakdown and also use the procedure in the printed matter which is included in the repair parts.

The flexible board is easily damaged and should be handled with care.

NOTES ON LASER DIODE EMISSION CHECK

The laser beam on this model is concentrated so as to be focused on the disc reflective surface by the objective lens in the optical pick-up block. Therefore, when checking the laser diode emission, observe more than 30 cm away from the objective lens.

LASER DIODE AND FOCUS SEARCH OPERATION CHECK

1. Turn POWER switch on with no disc inserted and disc table closed.
2. Confirm that the following operation is performed while observing the objecting lens.

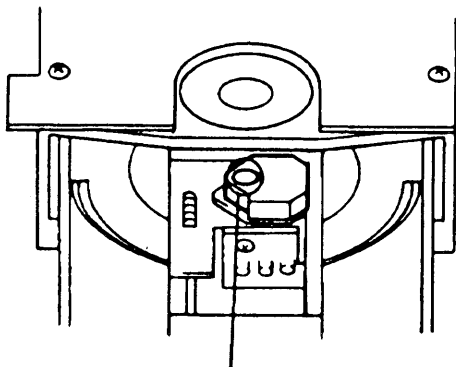

- ① Confirm that laser beam is spread.
- ② Up and down motion of the objective lens. (3 times)

CLASS 1 LASER PRODUCT
LUOKAN 1 LASERLAITE
KLASS 1 LASERAPPARAT

This appliance is classified as a CLASS 1 LASER product. The CLASS 1 LASER PRODUCT MARKING is located on the rear exterior.

The following caution label is located inside of the unit.

CAUTION	: INVISIBLE LASER RADIATION WHEN OPEN: AVOID EXPOSURE TO BEAM.
ADVARSEL	: USYNLIG LASERSTRÅLING VED ÅBNING NÅR SIKKERHEDSAFBRYDERE ER UDE AF FUNKTION. UNDGÅ UDSÆTTELSE FOR STRÅLING.
VARO!	: AVATTAESSA JA SUOJALUKITUS OHITETTAESSA OLET ALTIINA LASERSÄTEILYLLE.
VARNING	: LASERSTRÅLING NÅR DENNA DEL ÄR ÖPPNAD OCH SPARREN ÄR URKOPPLAD.
ADVARSEL	: USYNLIG LASERSTRÅLING NÅR DEKSEL ÅPNES UNNGÅ EKSPONERING FOR STRÅLEN.

SECTION 1 GENERAL

This section is extracted from instruction manual.

CDP-315/215

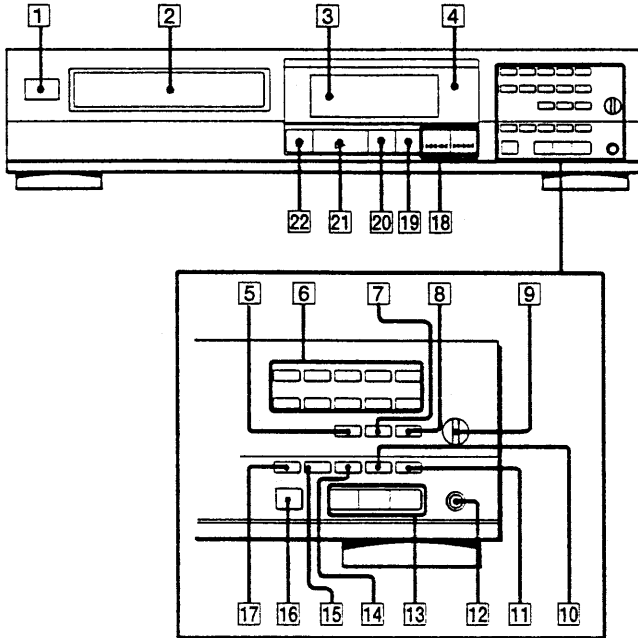

RM-D320

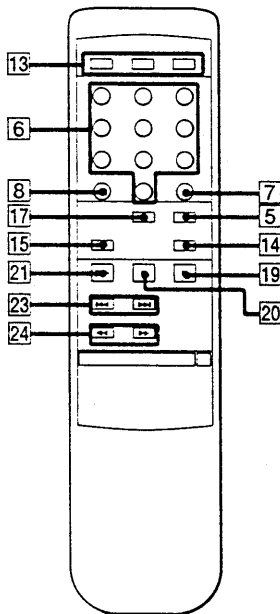

(only for CDP-315)

Identifying the Parts

Refer to the pages indicated in parenthesis for details.

Front Panel / Remote Commander

- 1 POWER switch (8)
- 2 Disc tray (8)
- 3 Display
- 4 Remote sensor
- 5 CHECK (program check) button (15)
- 6 Numeric buttons (10, 13, 14, 18, 20)
- 7 CLEAR (program clear) button (15)
- 8 >10 (over 10) button (10)
- 9 PHONE LEVEL control (8)
- 10 MUSIC SCAN button (16)
- 11 PEAK SEARCH button (21)
- 12 PHONES jack (8)
- 13 Play Mode buttons
CONTINUE button (12, 13, 19)
SHUFFLE button (12, 13, 19)
PROGRAM button (13, 14)
- 14 FADER button (11)
- 15 REPEAT button (17)
- 16 EDIT / TIME FADE button (18, 19, 20)
- 17 TIME button (9)
- 18 <<<</>>>> (AMS*/manual search) buttons (10, 11, 14, 16, 18, 20, 21)
- 19 ■ (stop) button (8)
- 20 || (pause) button (8)
- 21 ▷ (play) button (8)
- 22 ≡ OPEN/CLOSE button (8)
- 23 <<</>>> (AMS*) buttons (10, 14)
(Only on the remote commander)
- 24 <</>> (manual search) (11, 16)
(Only on the remote commander)

* AMS is the abbreviation of Automatic Music Sensor.

SECTION 2 DISASSEMBLY

NOTE: Follow the disassembly procedure in the numerical order given.

FRONT PANEL REMOVAL

When removing the front panel assembly on electric power failure, first open the loading block by turning cam with a screwdriver as shown in the figure, next pull out the loading block with hand, and remove the loading panel as shown in the figure, Then remove the front panel assembly.

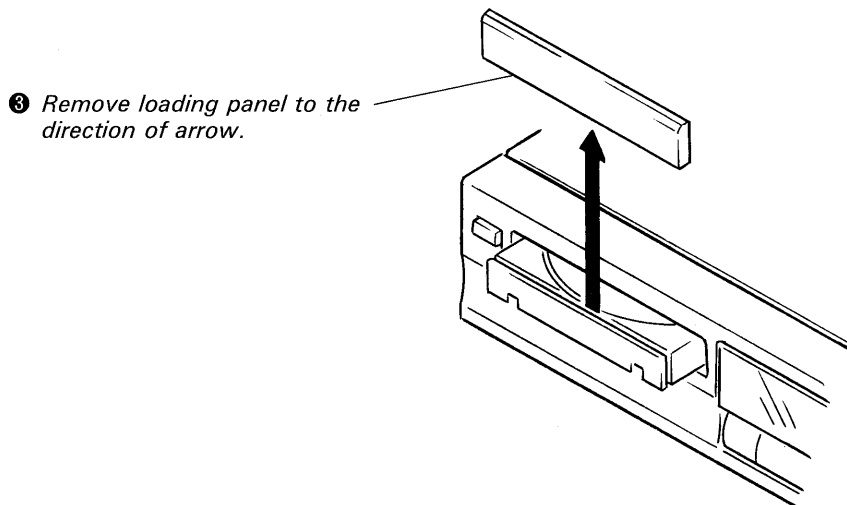
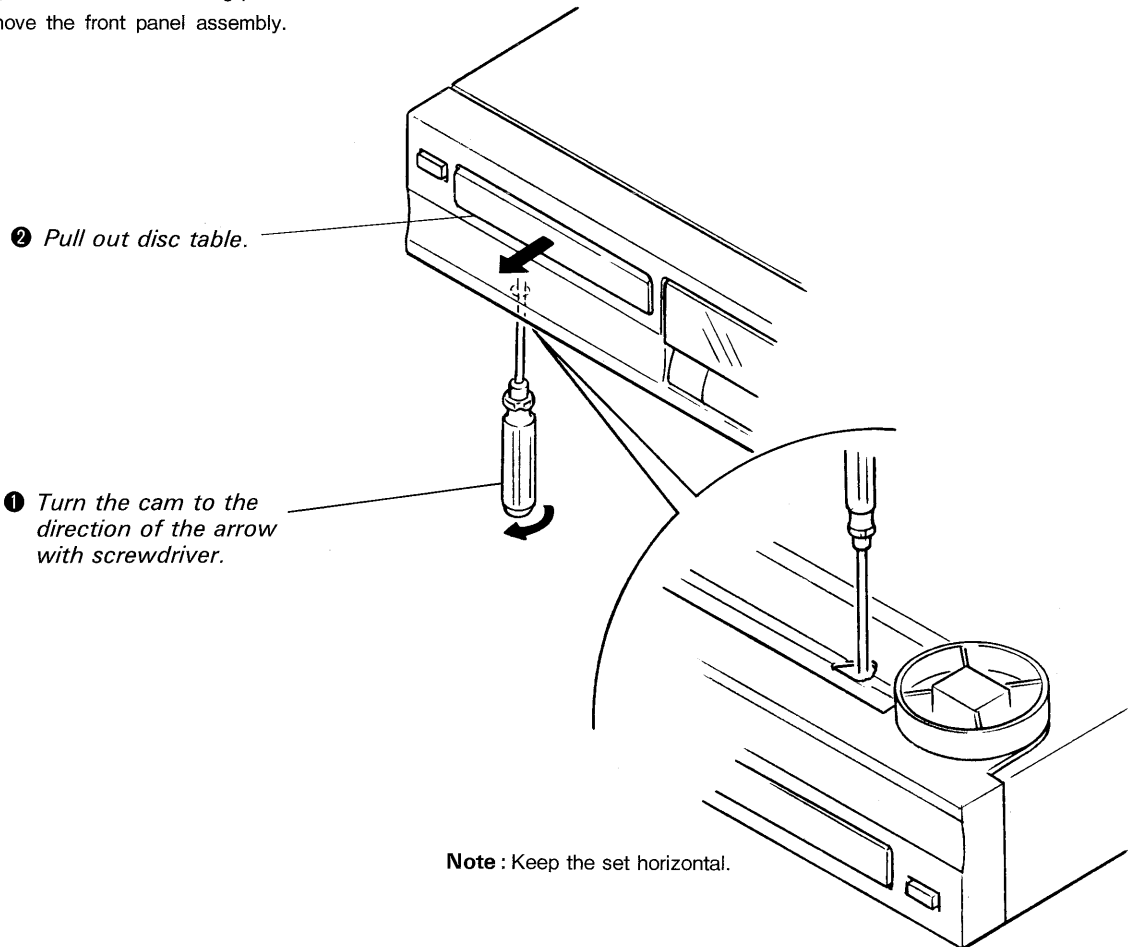

SECTION 3 ELECTRICAL BLOCK CHECKING

Note :

1. CD Block basically constructed to operate without adjustment. Therefore, check each item in order given.
2. Use YEDS-18 disc (3-702-101-01) unless otherwise indicated.
3. Use the oscilloscope with more than 10MΩ impedance.
4. Clean an object lens by an applicator with neutral detergent when the signal level is low than specified value with the following checks.

S-Curve Check

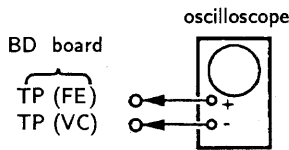

Procedure :

1. Connect oscilloscope to test point TP (FE) on BD board.
2. Connect between test point TP (TEI) and TP (VC) by lead wire.
3. Turned Power switch on.
4. Put disc (YEDS-18) in and turned Power switch on again and actuate the focus search. (actuate the focus search when disc table is moving in and out.)
5. Check the oscilloscope waveform (S-curve) is symmetrical between A and B. And confirm peak to peak level within $3 \pm 1V_{p-p}$.

S-curve waveform

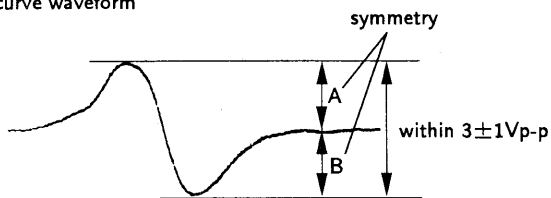

6. After check, remove the lead wire connected in step 2.

Note :

- Try to measure several times to make sure that the ratio of A : B or B : A is more than 10 : 7.
- Take sweep time as long as possible and light up the brightness to obtain best waveform.

RF Level Check

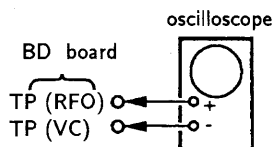

Procedure :

1. Connect oscilloscope to test point TP (RFO) on BD board.
2. Turned Power switch on.

3. Put disc (YEDS-18) in and playback.
4. Confirm that oscilloscope waveform is clear and check RF signal level is correct or not.

Note :

Clear RF signal waveform means that the shape “◇” can be clearly distinguished at the center of the waveform.

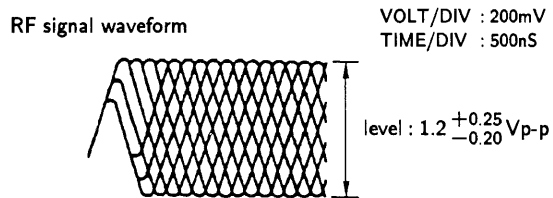

E-F Balance Check

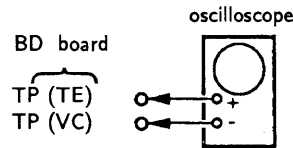

Procedure :

1. Connect test point TP (ADJ) to ground and TP (FEI) to TP (VC) with lead wire.
2. Connect oscilloscope to test point TP (TE) on BD board.
3. Turned Power switch on.
4. Put disc (YEDS-18) in and playback.
5. Confirm that the oscilloscope waveform is symmetrical on the top and bottom in relation to 0V, and check this level.

Traverse waveform

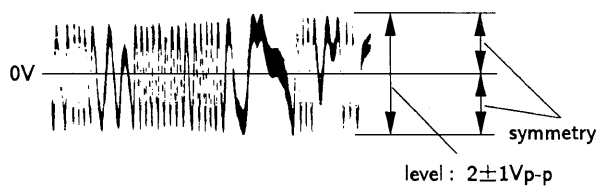

6. Remove the lead wire connected in step 1.

RF PLL Free-run Frequency Check

Procedure :

1. Connect frequency counter to test point (PCLK) with lead wire.
2. Turned Power switch on.
3. Confirm that reading on frequency counter is 4.3218MHz.

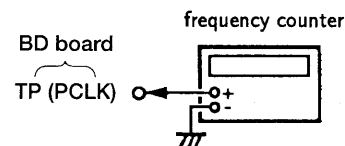

Adjustment Location :

【BD BOARD】

- Conductor side -

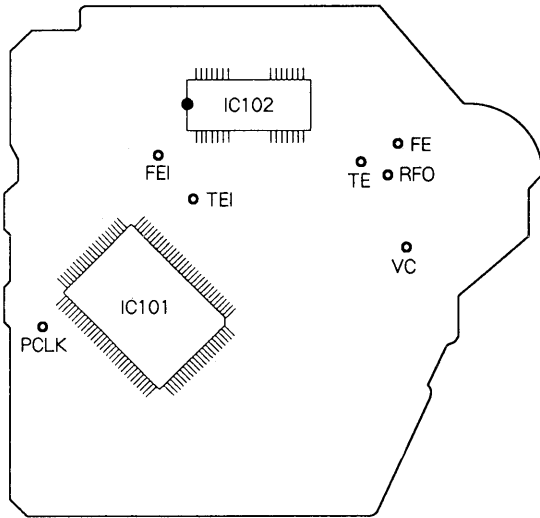

【MAIN BOARD】

- Conductor side -

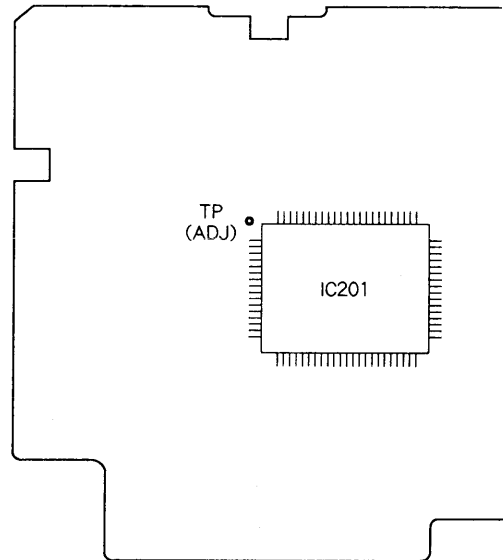

SECTION 4 DIAGRAMS

4-1. IC PIN DESCRIPTION

•IC101 CXD2515Q

No.	Pin Name	I/O	Description
1	SRON	O	Sled drive output
2	SRDR	O	Sled drive output
3	SFON	O	Sled drive output
4	TFDR	O	Tracking drive output
5	TRON	O	Tracking drive output
6	TRDR	O	Tracking drive output
7	TFON	O	Tracking drive output
8	FFDR	O	Focus drive output
9	FRON	O	Focus drive output
10	FRDR	O	Focus drive output
11	FFON	O	Focus drive output
12	VCOO	O	VCO output for analog EFM PLL
13	VCOI	I	VCO output for analog EFM PLL
14	TEST	I	TEST pin connected normally to GND
15	DVss	—	Digital GND
16	TES2	I	TEST pin connected normally to GND
17	TES3	I	TEST pin connected normally to GND
18	PDO	O	Charge-pump output for analog EFM PLL
19	VPCO	O	Charge-pump output for variable pitch PLL
20	VCKI	I	Clock input from variable pitch external VCO
21	AVD2	—	Analog power supply
22	IGEN	I	Power supply pin for operational amplifiers
23	AVS2	—	Analog GND
24	ADII	I	Input pin for A/D converter
25	ADIO	O	Operational amplifier output pin
26	RFDC	I	RF signal input
27	TE	I	Tracking error signal input
28	SE	I	Sled error signal input
29	FE	I	Focus error signal input
30	VC	I	Center voltage input pin
31	FILO	O	Filter output for master PLL
32	FILI	I	Filter input for master PLL
33	PCO	O	Charge-pump output for master PLL
34	CLTV	I	Control voltage input for master VCO
35	AVS1	—	Analog GND
36	RFAC	I	EFM signal input
37	BIAS	I	Asymmetry circuit constant current input
38	ASYI	I	Asymmetry compare voltage input
39	ASYO	O	EFM full swing output
40	AVD1	—	Analog power supply
41	DVDD	—	Digital power supply
42	ASYE	I	Asymmetry circuit ON/OFF
43	PSSL	I	Audio data output mode selection input
44	WDCK	O	48-bit slot D/A interface. Word clock
45	LRCK	O	48-bit slot D/A interface. LR clock

No.	Pin Name	I/O	Description
46	DATA	O	DA 16 output when PSSL = 1. 48-bit slot serial data when PSSL = 0
47	BCLK	O	DA 15 output when PSSL = 1. 48-bit slot data when PSSL = 0
48	64DATA	O	DA 14 output when PSSL = 1. 64-bit slot data when PSSL = 0
49	64BCLK	O	DA 13 output when PSSL = 1. 64-bit slot data when PSSL = 0
50	64LRCK	O	DA 12 output when PSSL = 1. 64-bit slot data when PSSL = 0
51	GTOP	O	DA 11 output when PSSL = 1. GTOP output when PSSL = 0
52	XUGF	O	DA 10 output when PSSL = 1. XUGF output when PSSL = 0
53	XPLCK	O	DA 09 output when PSSL = 1. XPLCK output when PSSL = 0
54	GFS	O	DA 08 output when PSSL = 1. GFS output when PSSL = 0
55	RFCK	O	DA 07 output when PSSL = 1. RFCK output when PSSL = 0
56	C2PO	O	DA 06 output when PSSL = 1. C2PO output when PSSL = 0
57	XRAOF	O	DA 05 output when PSSL = 1. XRAOF output when PSSL = 0
58	MNT3	O	DA 04 output when PSSL = 1. MNT3 output when PSSL = 0
59	MNT2	O	DA 03 output when PSSL = 1. MNT2 output when PSSL = 0
60	MNT1	O	DA 02 output when PSSL = 1. MNT1 output when PSSL = 0
61	MNT0	O	DA 01 output when PSSL = 1. MNT0 output when PSSL = 0
62	XTAI	I	X'tal oscillator circuit input
63	XTAO	O	X'tal oscillator circuit output
64	XTSL	I	X'tal selection input pin
65	DVss	—	Digital GND
66	FSTI	I	2/3 divider output of pins 62, 63
67	FSTO	O	2/3 divider output of pins 62, 63
68	C4M	O	4.2336MHz output
69	C16M	O	16.9344MHz output
70	MD2	I	Digital-out ON/OFF control pin
71	DOUT	O	Digital-out output pin
72	EMPH	O	Playback disc output in emphasis mode
73	WFCK	O	WFCK output
74	SCOR	O	Sub-code sync output
75	SBSO	O	Sub-P through Sub-W serial output
76	EXCK	I	Clock input for SBS0 read-out
77	SUBQ	O	Sub-Q 80-bit output
78	SQCK	I	Clock input for SQS0 read-out
79	MUTE	I	Muting selection pin
80	SENS	O	SENS output
81	XRST	I	System reset
82	DIRC	I	User in 1-track jump mode
83	SCLK	I	SENS serial data read-out clock
84	DFSW	I	DFCT selection pin
85	ATSK	I	Input pin for anti-shock
86	DATA	I	Serial data input, supplied from CPU
87	XLAT	I	Latch input, supplied from CPU
88	CLOK	I	Serial data transfer clock input, supplied from CPU
89	COUT	O	Numbers of track coated signal output
90	DVDD	—	Digital power supply
91	MIRR	O	Mirror signal output

No.	Pin Name	I/O	Description
92	DFCT	O	Defect signal output
93	FOK	O	Fucus Ok output
94	FSW	O	Output to select spindle motor output filter
95	MON	O	Output to control ON/OFF of spindle motor
96	MDP	O	Output to control spindle motor servo
97	MDS	O	Output to control spindle motor servo
98	LOCK	O	GFS is sampled by 460Hz. H when GFS is H.
99	SSTP	I	Input signal to detect disc inner most track
100	SFDR	O	Sled drive output

●IC201 CXP82316-037Q

No.	Pin Name	I/O	Description
1	+5V (TIMER)	I	Timer play and auto play setting; ON at H
2	RM (BUSIN)	I	Remote control/AU bus input; L active
3	+5V	—	+5V power supply
4	OPEN	—	Not used
5	OPEN	—	Not used
6	(BUS OUT)	—	Not used
7	PGML	O	Program latch to D/F
8	CLK	O	Command clock to D/F. 2515
9	SENSE	I	SENSE input from 2515
10	DATA	O	Command data to D/F. 2515
11	SQCK	O	Subcode Q read clock
12	SUBQ	I	Subcode Q read data
13	OPEN	—	Not used
14	AMUTE	O	Mute output; ON at H
15	LDON	O	Laser diode control; ON at H
16	XLT	O	Command latch to 2515
17	RVLED	—	Not used
18	RV+	—	Not used
19	RV-	—	Not used
20	LDOUT	O	Loading motor control
21	LDIN	O	Loading motor control
22 27	KEY0 KEY5	I	Key input; connect unused terminals to +5v
28	ADJ/AF ADJ	I	Test mode setting; ADJ and AF modes available
29	IN/OUT SW	I	Loading SW input; INSW and OUTSW are active
30	$\overline{\text{RST}}$	I	RESET input
31	EXTAL	I	Connect 4MHz ceramic oscillator
32	XTAL	I	Connect 4MHz ceramic oscillator
33	VSS	—	Ground
34 41	OPEN	—	Not used

No.	Pin Name	I/O	Description
42 62	S21 S1	O	Output of FL tube segments
63 67	1G 5G	O	Output of FL tube grids. Note: 8digits and 6digits require different connection
68	OPEN	—	Not used
69 70	6G 7G	O	Output of FL tube grids. Note: 8digits and 6digits require different connection
71	-30V (VFDP)	—	-30V power supply for FL tube
72	+5V (VDD)	—	+5v power supply
73	+5V	—	+5v power supply
74	GND	—	Ground
75 77	—	—	Not used
78	SCOR	I	Subcode sync input; Q data read at H→L
79	+5V	—	+5V power supply
80	+5V	—	+5V power supply

4-2. BLOCK DIAGRAM

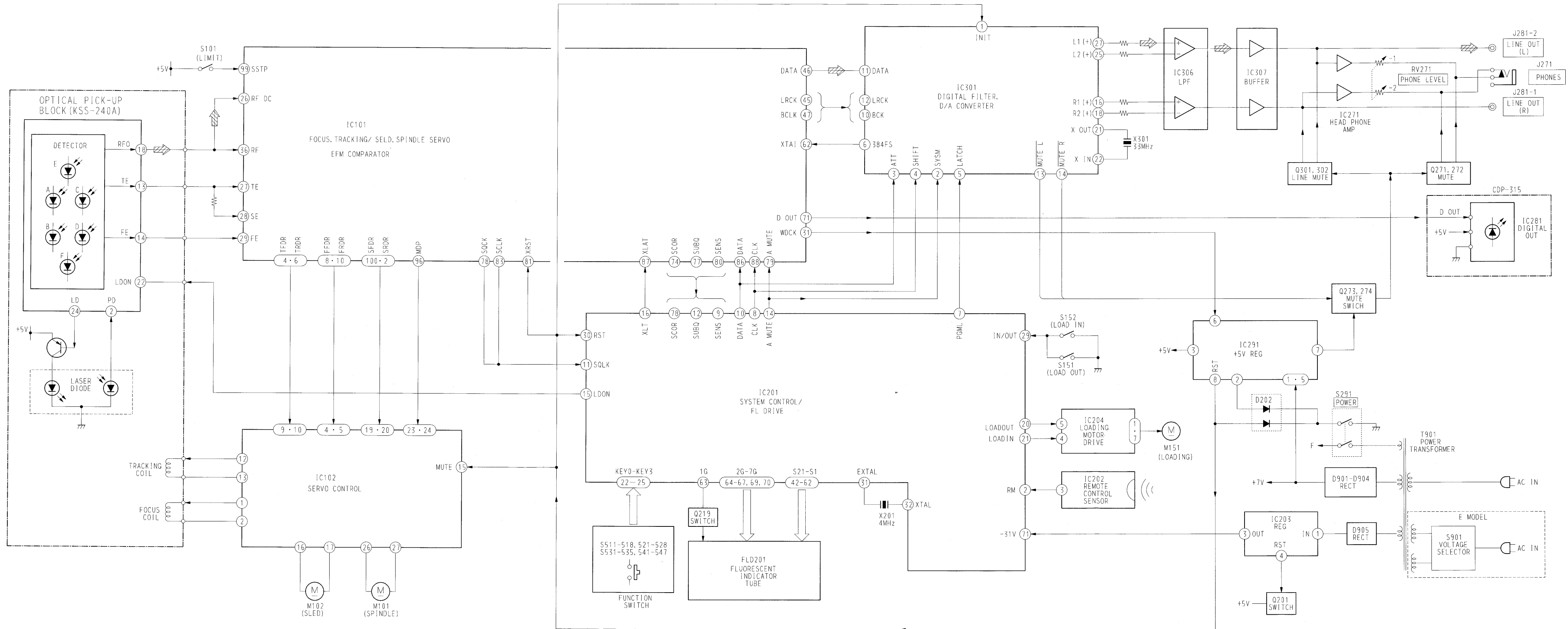

4-3. SEMICONDUCTOR LEAD LAYOUTS

BA6297AFP

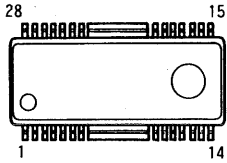

11ES2

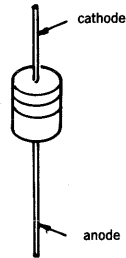

CXD2515Q

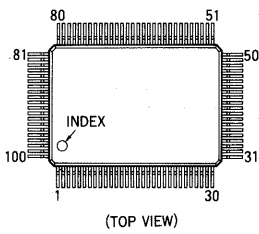

DA204K

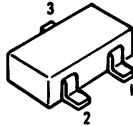

CXP82316-037Q

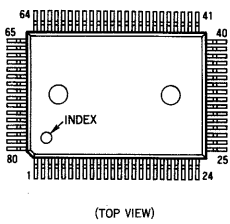

DAN202U

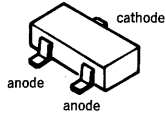

GP1U58XB

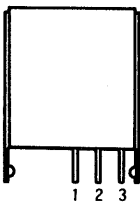

- 1 Vout
- 2 Vcc
- 3 GND

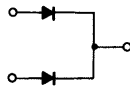

DAP202U

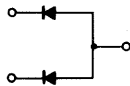
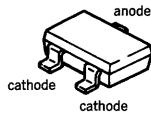

M5293L

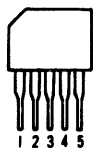

DTZ10B

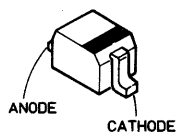

4-4. PRINTED WIRING BOARDS

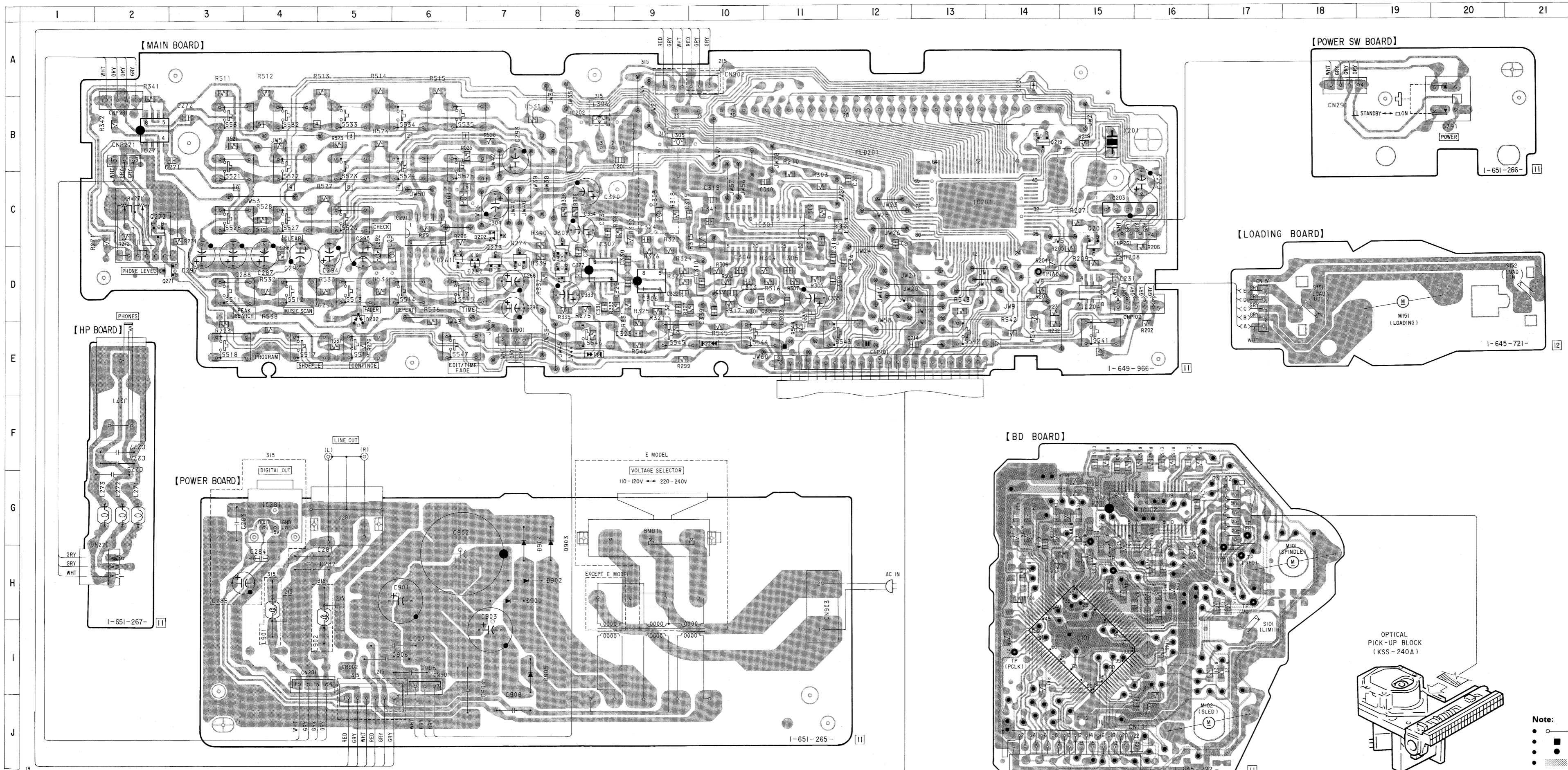

• Semiconductor Location

Ref. No.	Location
D201	A-14
D202	C-7
D261	D-6
D262	D-7
D292	D-5
D901	H-7
D902	H-7
D903	H-8
D904	H-7
D905	I-7
IC101	I-15
IC102	G-16
IC201	C-13
IC202	B-8
IC203	C-15
IC204	D-15
IC271	B-2
IC281	G-4
IC291	C-6
IC301	C-10
IC306	D-9
IC307	D-8
Q201	D-15
Q219	B-14
Q271	D-2
Q272	C-2
Q273	D-7
Q274	D-7
Q301	D-8
Q302	D-8

- Note:
- — : parts extracted from the component side.
 - : parts mounted on the conductor side.
 - : Through hole.
 - (with pattern) : Pattern on the side which is seen.
 - (with pattern) : Pattern of the rear side.

4-5. SCHEMATIC DIAGRAM

1 2 3 4 5 6 7 8 9 10 11 12 13 14 15 16 17 18 19 20 21 22 23 24

A B C D E F G H I J K L M N O P Q

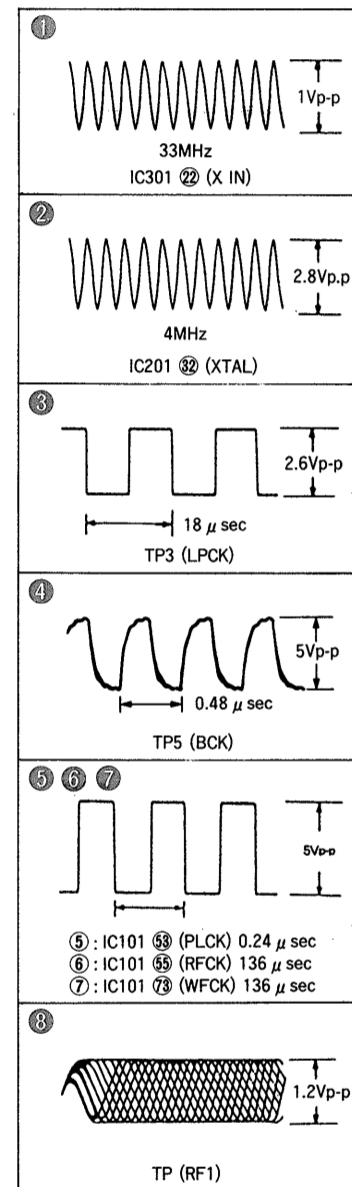
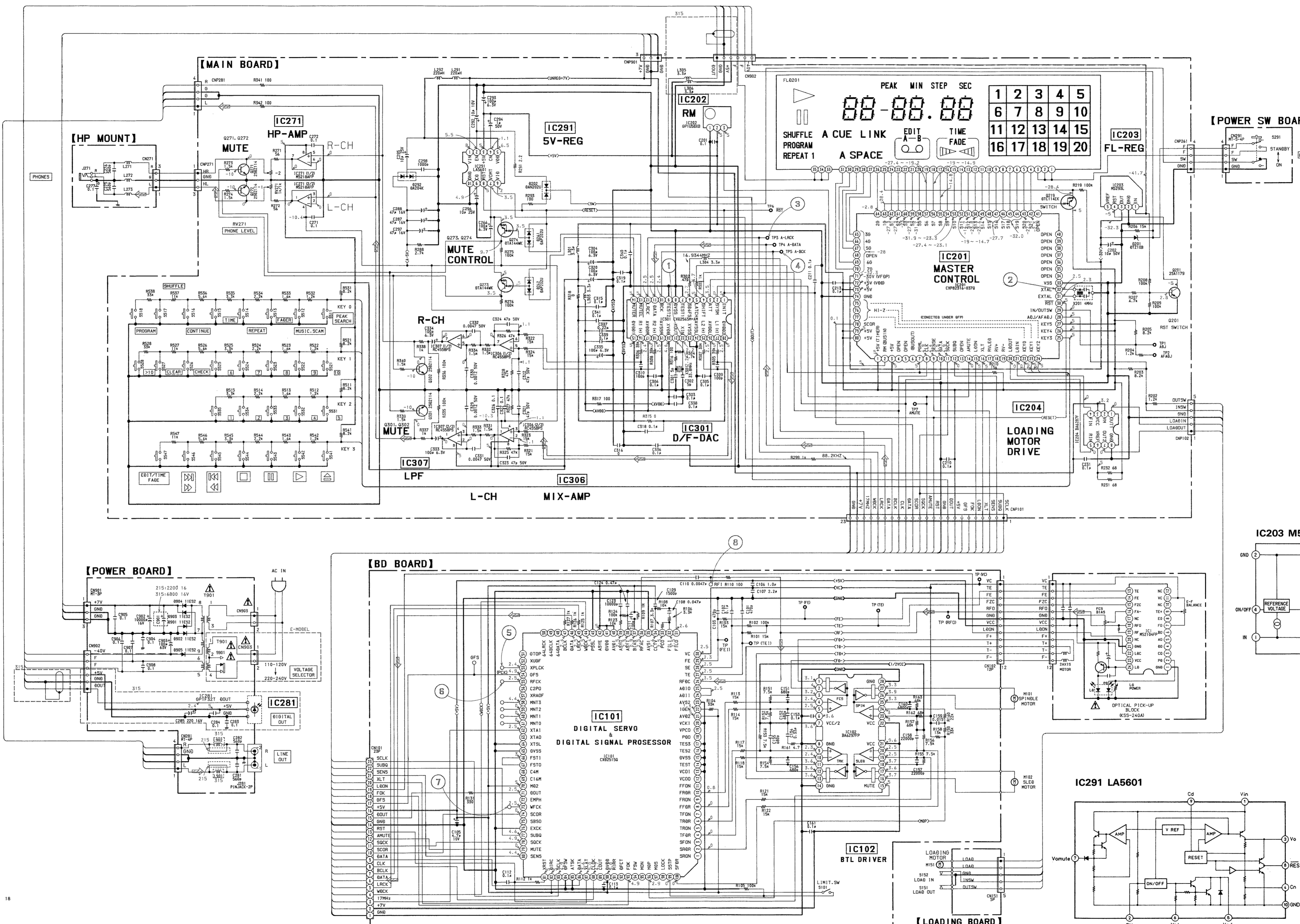

- Note:**
- All capacitors are in μF unless otherwise noted. pF: μF F 50WV or less are not indicated except for electrolytics and tantalums.
 - All resistors are in Ω and $\frac{1}{4}$ W or less unless otherwise specified.
- Note:** The components identified by mark Δ or dotted line with mark Δ are critical for safety. Replace only with part number specified.
- ———: B+ Line
 - - - - - -: B- Line
 - Voltage and waveforms are dc with respect to ground under no-signal (detuned) conditions. no mark: PLAY
 - Voltages are taken with a VOM (Input Impedance 10M Ω). Voltage variations may be noted due to normal production tolerances.
 - Waveforms are taken with an oscilloscope. Voltage variations may be noted due to normal production tolerances.
 - Circled numbers refer to waveforms.
 - Signal path
 - \Rightarrow : CD

IC Block Diagrams

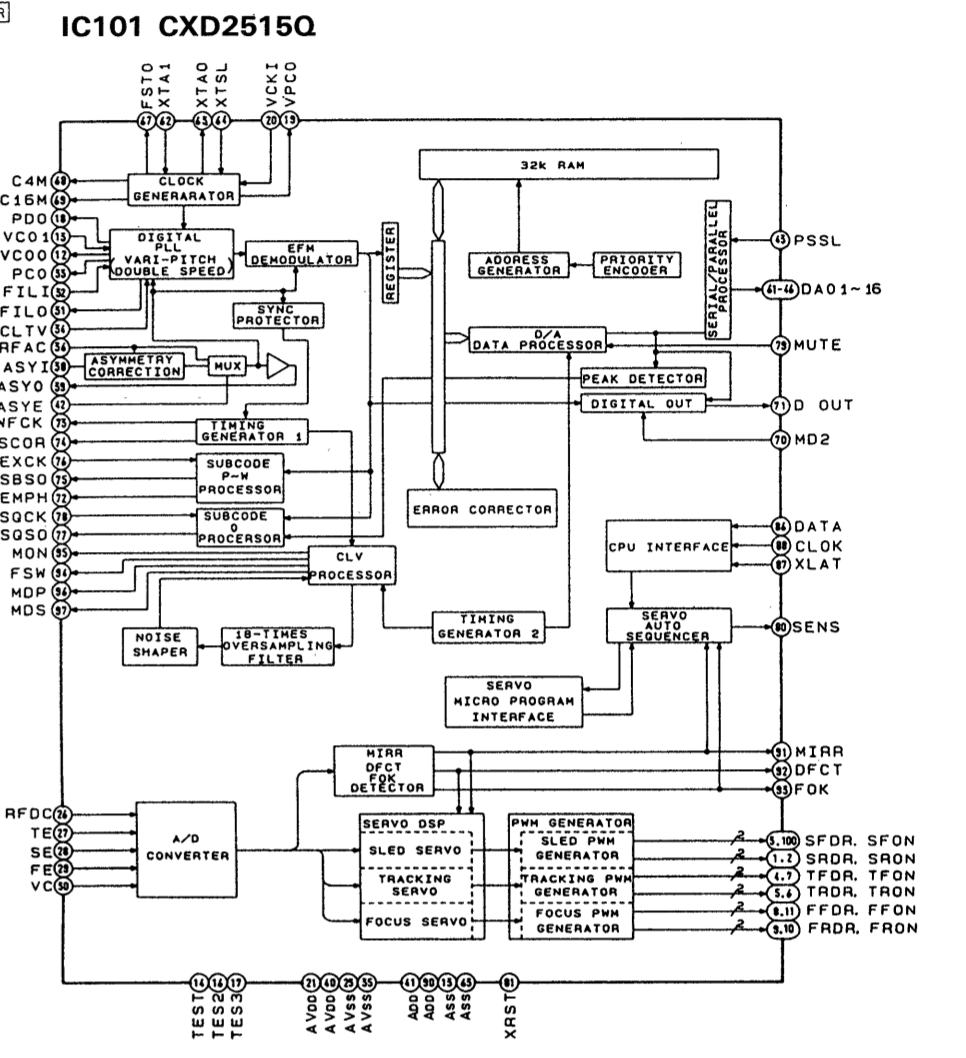

IC203 M5293L

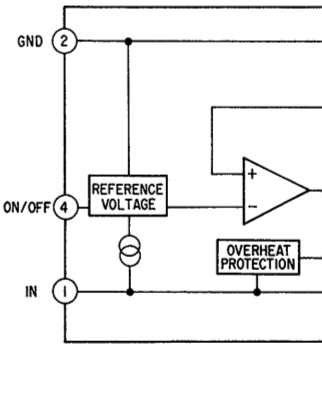

IC204 BA6287F

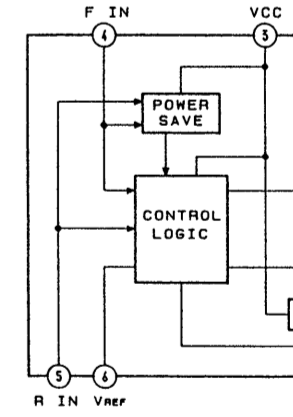

IC301 CXD2565AM

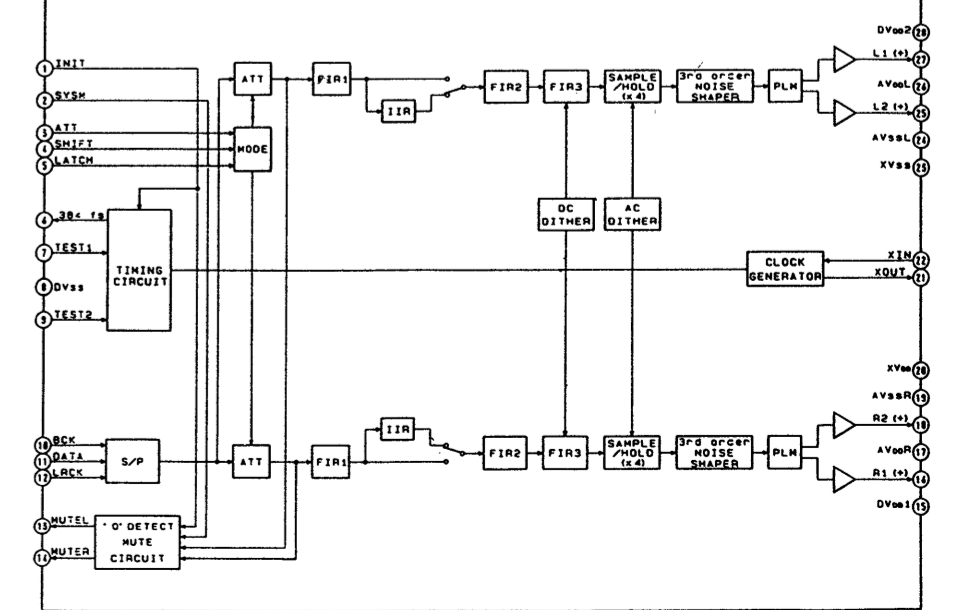

SECTION 5 EXPLODED VIEWS

NOTE:

- -xx-x mean standardized parts, so they may have some differences from the original one.

- Color Indication of Appearance Parts

Example:

KNOB, BALANCE (WHITE)...(RED)

↑ Parts color ↑ Cabinet's color

- Items marked "*" are not stocked since they are seldom required for routine service. Some delay should be anticipated when ordering these items.

- The mechanical parts with no reference number in the exploded views are not supplied.

- Hardware (#mark) list and accessories and packing materials are given in the last of this parts list.

The components identified by mark \triangle or dotted line with mark \triangle are critical for safety. Replace only with part number specified.

- Abbreviations

G: German

EE: East European

AUS: Australian

5-1. CABINET SECTION

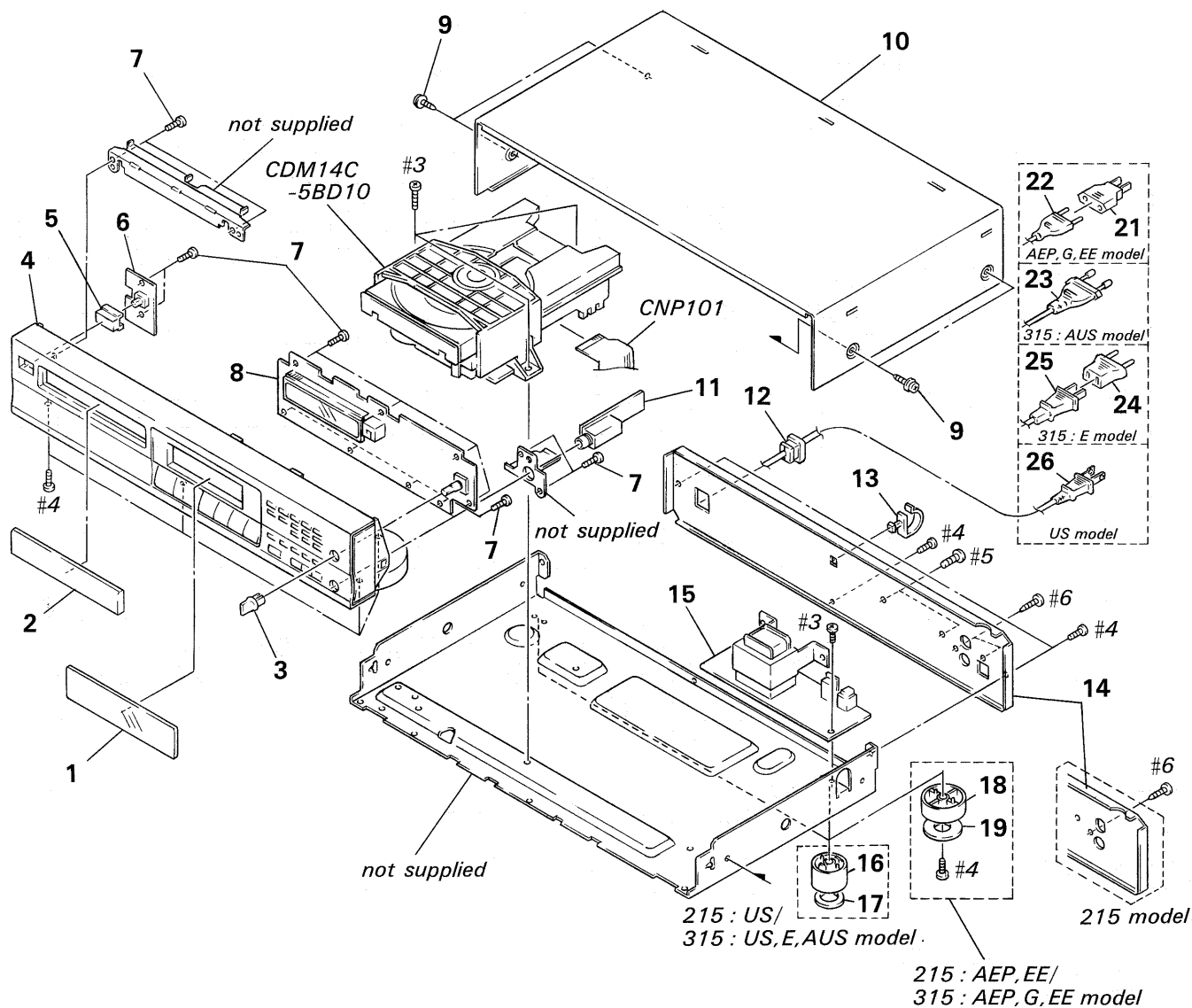

The components identified by mark \triangle or dotted line with mark \triangle are critical for safety. Replace only with part number specified.

Ref.No.	Part No.	Description	Remark
1	4-954-928-01	PLATE, INDICATION (315:AEP,G) (MADE IN FRANCE)	
1	4-954-928-11	PLATE, INDICATION (215:US,AEP,EE/315:US,AEP,E,EE,AUS)	
2	4-962-897-01	PANEL, LOADING (315:AEP,G) (MADE IN FRANCE)	
2	4-962-897-11	PANEL, LOADING (215:AEP) (MADE IN FRANCE)	
2	4-962-897-61	PANEL, LOADING (315:US,AEP,E,EE,AUS) (MADE IN CHINA)	
2	4-962-897-71	PANEL, LOADING (215:US,AEP,EE) (MADE IN CHINA)	
3	4-925-014-01	KNOB (DIA. 10)	
4	X-4944-106-1	PANEL ASSY, FRONT (315:AEP,G) (MADE IN FRANCE)	
4	X-4944-107-1	PANEL ASSY, FRONT (215:AEP) (MADE IN FRANCE)	
4	X-4944-470-1	PANEL ASSY, FRONT (315:AEP,E,EE,AUS) (MADE IN CHINA)	
4	X-4944-471-1	PANEL ASSY, FRONT (215:AEP,EE) (MADE IN CHINA)	
4	X-4944-796-1	PANEL ASSY, FRONT (315:US)	
4	X-4944-797-1	PANEL ASSY, FRONT (215:US)	
5	4-947-034-01	BUTTON (POWER)	
*6	1-651-266-11	POWER SW BOARD	
7	4-951-620-01	SCREW (2.6X8), +BVTP	
*8	A-4673-000-A	MAIN BOARD, COMPLETE (315)	
*8	A-4673-005-A	MAIN BOARD, COMPLETE (215)	
9	3-363-099-01	SCREW (CASE 3 TP2) (215:AEP/315:AEP,G) (MADE IN FRANCE)	
9	3-704-366-31	SCREW (CASE) (M3X6) (215:US,AEP,EE/315:US,AEP,EE,E,AUS) (MADE IN CHINA)	
10	4-929-035-31	CASE (AFTER BAP)	

Ref.No.	Part No.	Description	Remark
*11	1-651-267-11	HP BOARD	
*12	3-703-244-00	BUSHING (2104), CORD (315:US,AEP,G,EE,AUS)	
*12	3-703-571-11	BUSHING (S) (4516), CORD (315:E)	
*13	4-949-235-01	HOOK (215:AEP/315:AEP,G) (MADE IN FRANCE)	
*14	4-962-093-02	PANEL, BACK (315:AEP,G) (MADE IN FRANCE)	
*14	4-962-093-22	PANEL, BACK (215:AEP) (MADE IN FRANCE)	
*14	4-964-717-02	PANEL, BACK (315:AEP,EE) (MADE IN CHINA)	
*14	4-964-717-12	PANEL, BACK (315:E)	
*14	4-964-717-21	PANEL, BACK (315:AUS)	
*14	4-964-717-32	PANEL, BACK (215:AEP,EE) (MADE IN CHINA)	
*14	4-964-717-41	PANEL, BACK (315:US)	
*14	4-964-717-51	PANEL, BACK (215:US)	
*15	1-651-265-11	POWER BOARD	
16	4-964-090-01	FOOT (F22175H-M) (215:US/315:US,E,AUS)	
17	4-964-668-01	CUSHION (DIA. 16) (215:US/315:US,E,AUS)	
18	4-930-848-01	FOOT (F58175S) (215:AEP,EE/315:AEP,G,EE)	
19	4-923-836-11	CUSHION (215:AEP,EE/315:AEP,G,EE)	
\triangle 21	1-569-007-11	ADAPTER, CONVERSION 2P	
\triangle 22	1-575-651-21	CORD, POWER (AEP,G,EE)	
\triangle 23	1-696-845-11	CORD, POWER (315:AUS)	
\triangle 24	1-569-007-11	ADAPTER, CONVERSION 2P (315:E)	
\triangle 25	1-558-943-41	CORD, POWER (315:E)	
\triangle 26	1-590-926-11	CORD, POWER (US)	
CNP101	1-537-472-11	JUMPER, FILM (WITH TERMINAL)	

5-2. CD MECHANISM SECTION (CDM14C-5BD10)

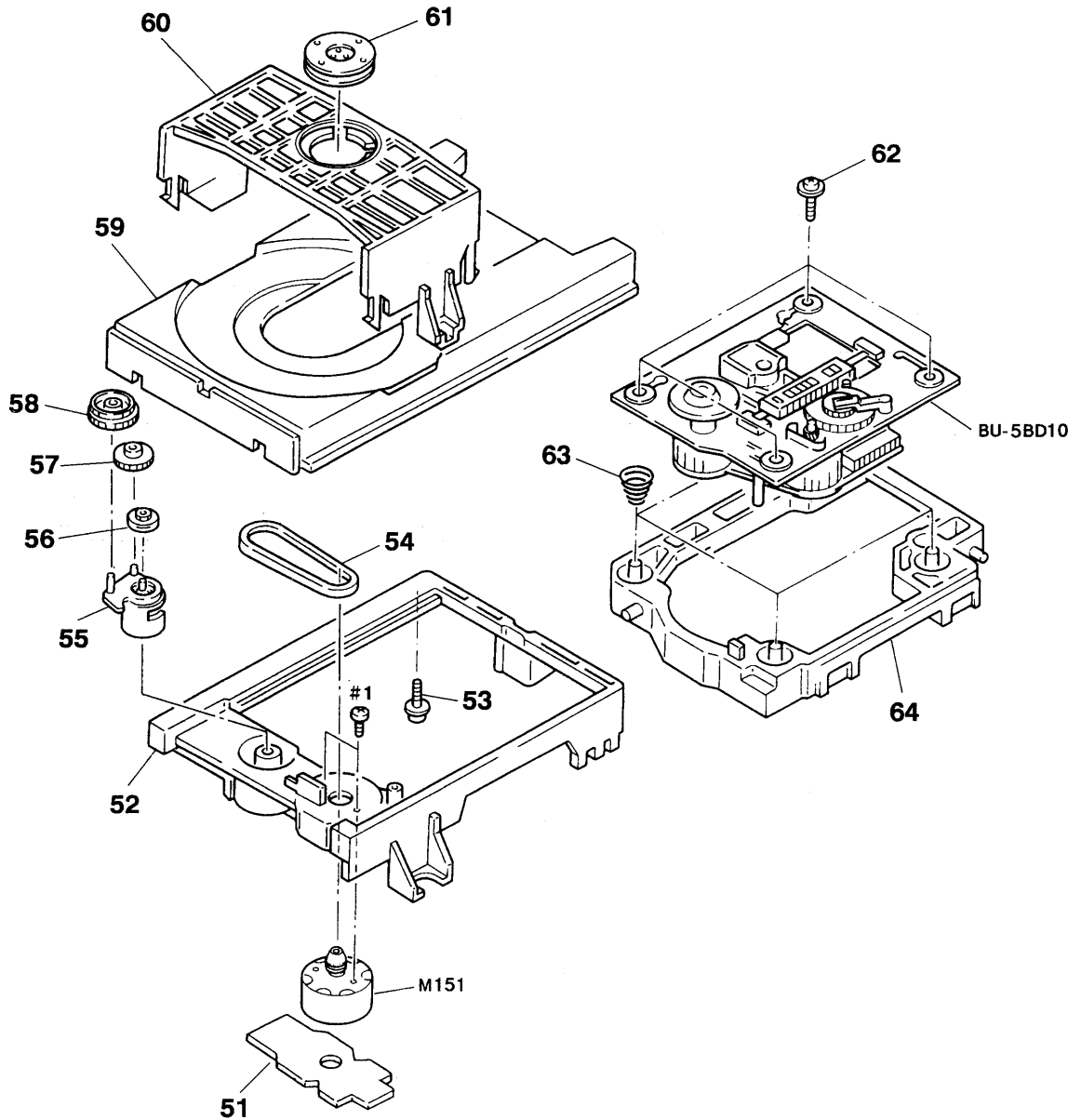

Ref.No.	Part No.	Description	Remark
*51	1-645-721-11	LOADING BOARD	
52	4-933-111-01	CHASSIS (MD) (MADE IN CHINA)	
52	4-933-111-11	CHASSIS (MD) (MADE IN FRANCE)	
*53	4-917-583-21	BRACKET, YOKE	
54	4-927-649-01	BELT	
55	4-933-109-01	CAM	
56	4-927-651-01	PULLEY (S)	
57	4-927-628-01	GEAR (C)	
58	4-933-107-01	GEAR (PL)	

Ref.No.	Part No.	Description	Remark
59	4-933-112-01	TABLE, DISK (MADE IN CHINA)	
59	4-933-112-11	TABLE, DISK (MADE IN FRANCE)	
60	4-933-110-01	HOLDER (MG) (MADE IN CHINA)	
60	4-933-110-11	HOLDER (MG) (MADE IN FRANCE)	
*61	1-452-538-11	MAGNET	
62	4-933-134-01	SCREW (+PTPWH M2.6X6)	
63	4-959-996-01	SPRING (932), COMPRESSION	
64	4-933-129-01	HOLDER (BU)	
M151	A-4604-363-A	MOTOR (L) ASSY (LOADING)	

5-3. OPTICAL PICK-UP BLOCK (BU-5BD10)

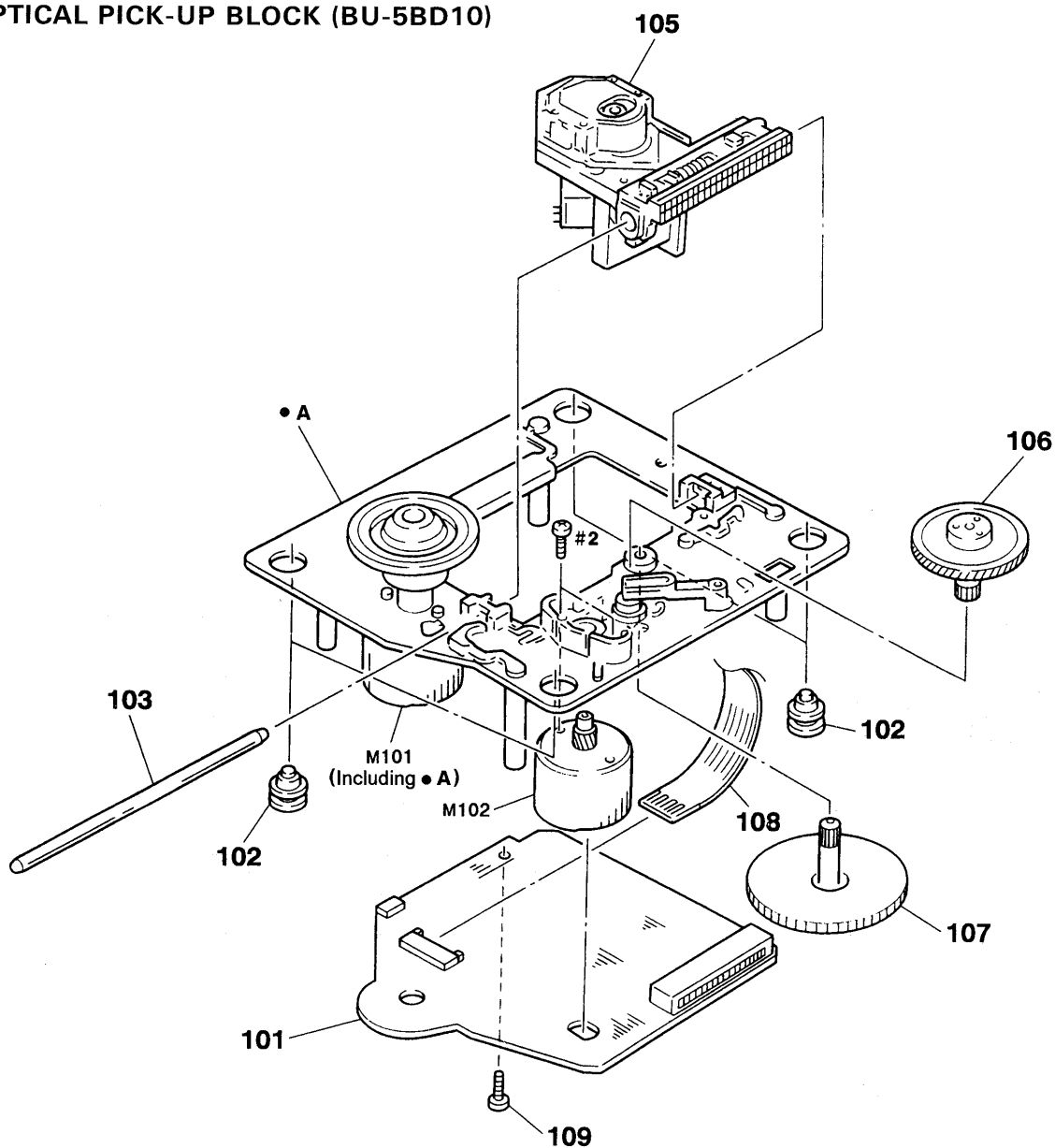

The components identified by mark \triangle or dotted line with mark \triangle are critical for safety. Replace only with part number specified.

Ref.No.	Part No.	Description	Remark
* 101	A-4649-430-A	BD BOARD, COMPLETE (MADE IN FRANCE)	
* 101	A-4649-432-A	BD BOARD, COMPLETE (MADE IN CHINA)	
102	4-951-940-01	INSULATOR (BU)	
103	4-917-565-01	SHAFT, SLED	
\triangle 105	8-848-144-11	DEVICE, OPTICAL KSS-240A	
106	4-917-567-01	GEAR (M)	

Ref.No.	Part No.	Description	Remark
107	4-917-564-01	GEAR (P), FLATNESS	
108	1-575-001-11	WIRE, FLAT TYPE (12 CORE)	
109	4-951-620-01	SCREW (2.6X8), +BVTP	
M101	X-4917-523-3	MOTOR ASSY (SPINDLE)	
M102	X-4917-504-1	MOTOR ASSY (SLED)	

SECTION 6 ELECTRICAL PARTS LIST

BD

NOTE:

- Due to standardization, replacements in the parts list may be different from the parts specified in the diagrams or the components used on the set.
- -XX and -X mean standardized parts, so they may have some difference from the original one.
- RESISTORS
All resistors are in ohms.
METAL: Metal-film resistor.
METAL OXIDE: Metal oxide-film resistor.
F: nonflammable

- Items marked “*” are not stocked since they are seldom required for routine service. Some delay should be anticipated when ordering these items.
- SEMICONDUCTORS
In each case, u : μ , for example:
uA... : μ A..., uPA... : μ PA..., uPB... : μ PB...,
uPC... : μ PC..., uPD... : μ PD...
- CAPACITORS
uF : μ F
- COILS
uH : μ H

The components identified by mark Δ or dotted line with mark Δ are critical for safety. Replace only with part number specified.

- Abbreviations
G: German
EE: East European
AUS: Australian

When indicating parts by reference number, please include the board.

Ref.No.	Part No.	Description	Remark
*	A-4649-432-A	BD BOARD, COMPLETE (MADE IN CHINA)	
*	A-4649-430-A	BD BOARD, COMPLETE (MADE IN FRANCE)	

< CAPACITOR >			
C101	1-163-005-11	CERAMIC CHIP 470PF	10% 50V
C102	1-163-038-00	CERAMIC CHIP 0.1uF	25V
C103	1-163-005-11	CERAMIC CHIP 470PF	10% 50V
C105	1-135-155-21	TANTALUM CHIP 4.7uF	10% 16V (MADE IN CHINA)
C105	1-135-287-91	TANTAL CHIP 4.7uF	20% 16V (MADE IN FRANCE)
C106	1-164-346-11	CERAMIC CHIP 1uF	16V
C107	1-164-505-11	CERAMIC CHIP 2.2uF	16V
C108	1-163-035-00	CERAMIC CHIP 0.047uF	50V
C109	1-163-011-11	CERAMIC CHIP 0.0015uF	10% 50V
C110	1-163-017-00	CERAMIC CHIP 0.0047uF	5% 50V
C111	1-163-251-11	CERAMIC CHIP 100PF	5% 50V
C112	1-163-038-00	CERAMIC CHIP 0.1uF	25V
C113	1-163-038-00	CERAMIC CHIP 0.1uF	25V
C123	1-164-232-11	CERAMIC CHIP 0.01uF	50V
C124	1-164-005-11	CERAMIC CHIP 0.47uF	25V
C151	1-163-007-11	CERAMIC CHIP 680PF	10% 50V
C152	1-163-007-11	CERAMIC CHIP 680PF	10% 50V
C153	1-163-038-00	CERAMIC CHIP 0.1uF	25V
C154	1-164-336-11	CERAMIC CHIP 0.33uF	25V
C155	1-163-007-11	CERAMIC CHIP 680PF	10% 50V
C156	1-163-007-11	CERAMIC CHIP 680PF	10% 50V
C157	1-163-033-00	CERAMIC CHIP 0.022uF	50V
C158	1-163-033-00	CERAMIC CHIP 0.022uF	50V
C159	1-163-023-00	CERAMIC CHIP 0.015uF	5% 50V
C160	1-163-019-00	CERAMIC CHIP 0.0068uF	10% 50V
C161	1-163-038-00	CERAMIC CHIP 0.1uF	25V
< CONNECTOR >			
*CN101	1-568-865-11	SOCKET, CONNECTOR 23P	
CN102	1-568-795-11	SOCKET, CONNECTOR 12P	

Ref.No.	Part No.	Description	Remark
< IC >			
IC101	8-752-361-90	IC CXD2515Q	
IC102	8-759-071-79	IC BA6297AFP	
< RESISTOR >			
R101	1-216-077-00	METAL CHIP 15K 5%	1/10W
R102	1-216-097-00	METAL CHIP 100K 5%	1/10W
R103	1-216-077-00	METAL CHIP 15K 5%	1/10W
R104	1-216-085-00	METAL CHIP 33K 5%	1/10W
R105	1-216-097-00	METAL CHIP 100K 5%	1/10W
R106	1-216-061-00	METAL CHIP 3.3K 5%	1/10W
R107	1-216-061-00	METAL CHIP 3.3K 5%	1/10W
R108	1-216-073-00	METAL CHIP 10K 5%	1/10W
R109	1-216-121-00	METAL CHIP 1M 5%	1/10W
R110	1-216-025-00	METAL CHIP 100 5%	1/10W
R112	1-216-049-00	METAL CHIP 1K 5%	1/10W
R113	1-216-077-00	METAL CHIP 15K 5%	1/10W
R114	1-216-077-00	METAL CHIP 15K 5%	1/10W
R117	1-216-077-00	METAL CHIP 15K 5%	1/10W
R118	1-216-077-00	METAL CHIP 15K 5%	1/10W
R121	1-216-077-00	METAL CHIP 15K 5%	1/10W
R122	1-216-077-00	METAL CHIP 15K 5%	1/10W
R123	1-216-073-00	METAL CHIP 10K 5%	1/10W
R124	1-216-097-00	METAL CHIP 100K 5%	1/10W
R125	1-216-049-00	METAL CHIP 1K 5%	1/10W
R126	1-216-049-00	METAL CHIP 1K 5%	1/10W
R127	1-216-049-00	METAL CHIP 1K 5%	1/10W
R131	1-216-037-00	METAL CHIP 330 5%	1/10W
R151	1-216-070-00	METAL CHIP 7.5K 5%	1/10W
R152	1-216-070-00	METAL CHIP 7.5K 5%	1/10W
R153	1-216-070-00	METAL CHIP 7.5K 5%	1/10W
R154	1-216-070-00	METAL CHIP 7.5K 5%	1/10W
R155	1-216-070-00	METAL CHIP 7.5K 5%	1/10W
R156	1-216-070-00	METAL CHIP 7.5K 5%	1/10W
R157	1-216-093-00	METAL CHIP 68K 5%	1/10W
R158	1-216-076-00	METAL CHIP 13K 5%	1/10W
R159	1-216-085-00	METAL CHIP 33K 5%	1/10W
R160	1-216-081-00	METAL CHIP 22K 5%	1/10W
R161	1-216-308-00	METAL CHIP 4.7 5%	1/10W

BD **LOADING** **MAIN**

Ref.No.	Part No.	Description	Remark	
R162	1-216-093-00	METAL CHIP	68K 5%	1/10W
R163	1-216-093-00	METAL CHIP	68K 5%	1/10W
< SWITCH >				
S101	1-572-085-11	SWITCH, LEAF (LIMIT)		

*	1-645-721-12	LOADING BOARD		

< CONNECTOR >				
*CN151	1-568-943-11	PIN, CONNECTOR 5P		
< SWITCH >				
S151	1-572-086-11	SWITCH, LEAF (LOAD OUT)		
S152	1-572-086-11	SWITCH, LEAF (LOAD IN)		

*	A-4673-005-A	MAIN BOARD, COMPLETE (215)		
*	A-4673-000-A	MAIN BOARD, COMPLETE (315)		

< CAPACITOR >				
C201	1-163-038-00	CERAMIC CHIP	0.1uF	25V
C202	1-124-261-00	ELECT	10uF	20% 50V
C210	1-163-038-00	CERAMIC CHIP	0.1uF	25V
C211	1-163-038-00	CERAMIC CHIP	0.1uF	25V
C213	1-163-038-00	CERAMIC CHIP	0.1uF	25V
C231	1-163-038-00	CERAMIC CHIP	0.1uF	25V
C266	1-124-584-00	ELECT	100uF	20% 10V
C271	1-163-038-00	CERAMIC CHIP	0.1uF	25V
C272	1-163-038-00	CERAMIC CHIP	0.1uF	25V
C287	1-124-589-11	ELECT	47uF	20% 16V
C288	1-124-589-11	ELECT	47uF	20% 16V
C292	1-126-157-11	ELECT	10uF	20% 16V
C293	1-124-584-00	ELECT	100uF	20% 10V
C294	1-126-160-11	ELECT	1uF	20% 50V
C295	1-126-096-11	ELECT	10uF	20% 35V
C296	1-126-096-11	ELECT	10uF	20% 35V
C297	1-124-589-11	ELECT	47uF	20% 16V
C298	1-163-275-11	CERAMIC CHIP	0.001uF	5% 50V
C301	1-163-088-00	CERAMIC CHIP	5PF	50V
C302	1-163-088-00	CERAMIC CHIP	5PF	50V
C303	1-163-038-00	CERAMIC CHIP	0.1uF	25V

Ref.No.	Part No.	Description	Remark	
C304	1-124-584-00	ELECT	100uF	20% 10V
C305	1-163-038-00	CERAMIC CHIP	0.1uF	25V
C306	1-163-038-00	CERAMIC CHIP	0.1uF	25V
C309	1-163-251-11	CERAMIC CHIP	100PF	5% 50V
C310	1-163-251-11	CERAMIC CHIP	100PF	5% 50V
C315	1-163-038-00	CERAMIC CHIP	0.1uF	25V
C316	1-216-295-00	METAL CHIP	0 5%	1/10W
C318	1-163-038-00	CERAMIC CHIP	0.1uF	25V
C319	1-163-038-00	CERAMIC CHIP	0.1uF	25V
C320	1-124-584-00	ELECT	100uF	20% 10V
C321	1-163-243-11	CERAMIC CHIP	47PF	5% 50V
C322	1-163-243-11	CERAMIC CHIP	47PF	5% 50V
C323	1-163-243-11	CERAMIC CHIP	47PF	5% 50V
C324	1-163-243-11	CERAMIC CHIP	47PF	5% 50V
C326	1-163-038-00	CERAMIC CHIP	0.1uF	25V
C327	1-163-038-00	CERAMIC CHIP	0.1uF	25V
C329	1-163-143-00	CERAMIC CHIP	0.0012uF	5% 50V
C330	1-163-143-00	CERAMIC CHIP	0.0012uF	5% 50V
C331	1-163-017-00	CERAMIC CHIP	0.0047uF	5% 50V
C332	1-163-017-00	CERAMIC CHIP	0.0047uF	5% 50V
C333	1-124-584-00	ELECT	100uF	20% 10V
C334	1-124-584-00	ELECT	100uF	20% 10V
C335	1-124-584-00	ELECT	100uF	20% 10V
C336	1-163-038-00	CERAMIC CHIP	0.1uF	25V
C337	1-163-081-00	CERAMIC CHIP	0.22uF	25V
C338	1-163-038-00	CERAMIC CHIP	0.1uF	25V
C339	1-163-038-00	CERAMIC CHIP	0.1uF	25V
C340	1-163-038-00	CERAMIC CHIP	0.1uF	25V
C341	1-163-038-00	CERAMIC CHIP	0.1uF	25V
< CONNECTOR >				
*CN902	1-564-708-11	PIN, CONNECTOR (SMALL TYPE) 6P (315)		
CNP101	1-537-472-11	JUMPER, FILM (WITH TERMINAL) (MADE IN CHINA)		
CNP101	1-537-472-21	JUMPER, FILM (WITH TERMINAL) (MADE IN FRANCE)		
< DIODE >				
D201	8-719-977-28	DIODE DTZ10B		
D202	8-719-941-86	DIODE DAN202U		
D261	8-719-941-09	DIODE DAP202U		
D262	8-719-941-09	DIODE DAP202U		
D292	8-719-914-42	DIODE DA204K		
< FLUORECENT INDICATOR >				
FLD201	1-519-752-11	INDICATOR TUBE, FLUORESCENT		

Ref.No.	Part No.	Description	Remark
< IC >			
IC201	8-752-851-82	IC CXP82316-037Q	
IC202	8-749-923-11	IC GPIU58XB	
IC203	8-759-633-42	IC M5293L	
IC204	8-759-040-83	IC BA6287F	
IC271	8-759-636-55	IC M5218AFP	
IC291	8-759-821-93	IC LA5601	
IC301	8-752-367-61	IC CXD2565AM	
IC306	8-759-996-43	IC RC4558PS	
IC307	8-759-996-43	IC RC4558PS	
< COIL >			
L291	1-410-658-31	INDUCTOR CHIP 220uH	
L292	1-410-658-31	INDUCTOR CHIP 220uH	
L301	1-410-375-11	INDUCTOR CHIP 3.3uH	
L303	1-410-375-11	INDUCTOR CHIP 3.3uH	
L304	1-410-375-11	INDUCTOR CHIP 3.3uH	
L305	1-410-375-11	INDUCTOR CHIP 3.3uH (315)	
L306	1-410-375-11	INDUCTOR CHIP 3.3uH (315)	
< TRANSISTOR >			
Q201	8-729-820-76	TRANSISTOR 2SA1179-M5M6	
Q219	8-729-900-53	TRANSISTOR DTC114EK	
Q271	8-729-023-22	TRANSISTOR 2SD2114K	
Q272	8-729-023-22	TRANSISTOR 2SD2114K	
Q273	8-729-900-99	TRANSISTOR DTA144WK	
Q274	8-729-900-99	TRANSISTOR DTA144WK	
Q301	8-729-023-22	TRANSISTOR 2SD2114K	
Q302	8-729-023-22	TRANSISTOR 2SD2114K	
< RESISTOR >			
R202	1-216-051-00	METAL CHIP 1.2K 5% 1/10W	
R203	1-216-071-00	METAL CHIP 8.2K 5% 1/10W	
R204	1-216-051-00	METAL CHIP 1.2K 5% 1/10W	
R205	1-216-071-00	METAL CHIP 8.2K 5% 1/10W	
R206	1-216-077-00	METAL CHIP 15K 5% 1/10W	
R207	1-216-065-00	METAL CHIP 4.7K 5% 1/10W	
R208	1-216-097-00	METAL CHIP 100K 5% 1/10W	
R209	1-216-097-00	METAL CHIP 100K 5% 1/10W	
R210	1-216-077-00	METAL CHIP 15K 5% 1/10W	
R219	1-216-097-00	METAL CHIP 100K 5% 1/10W	
R231	1-216-021-00	METAL CHIP 68 5% 1/10W	
R232	1-216-021-00	METAL CHIP 68 5% 1/10W	
R271	1-216-019-00	METAL CHIP 56 5% 1/10W	
R272	1-216-019-00	METAL CHIP 56 5% 1/10W	
R273	1-216-053-00	METAL CHIP 1.5K 5% 1/10W	
R274	1-216-053-00	METAL CHIP 1.5K 5% 1/10W	
R275	1-216-097-00	METAL CHIP 100K 5% 1/10W	

Ref.No.	Part No.	Description	Remark
R276	1-216-097-00	METAL CHIP 100K 5% 1/10W	
R288	1-216-059-00	METAL CHIP 2.7K 5% 1/10W	
R291	1-216-298-00	METAL CHIP 2.2 5% 1/10W	
R293	1-216-025-00	METAL CHIP 100 5% 1/10W	
R299	1-216-049-00	METAL CHIP 1K 5% 1/10W	
R302	1-216-041-00	METAL CHIP 470 5% 1/10W	
R303	1-216-049-00	METAL CHIP 1K 5% 1/10W	
R304	1-216-065-00	METAL CHIP 4.7K 5% 1/10W	
R305	1-216-689-11	METAL CHIP 39K 0.5% 1/10W	
R306	1-216-689-11	METAL CHIP 39K 0.5% 1/10W	
R307	1-216-689-11	METAL CHIP 39K 0.5% 1/10W	
R308	1-216-689-11	METAL CHIP 39K 0.5% 1/10W	
R315	1-216-296-91	METAL GLAZE 0 5% 1/8W	
R316	1-216-025-00	METAL CHIP 100 5% 1/10W	
R317	1-216-025-00	METAL CHIP 100 5% 1/10W	
R318	1-216-295-00	METAL CHIP 0 5% 1/10W	
R321	1-216-077-00	METAL CHIP 15K 5% 1/10W	
R322	1-216-077-00	METAL CHIP 15K 5% 1/10W	
R323	1-216-077-00	METAL CHIP 15K 5% 1/10W	
R324	1-216-077-00	METAL CHIP 15K 5% 1/10W	
R325	1-216-089-91	METAL GLAZE 47K 5% 1/10W	
R326	1-216-089-91	METAL GLAZE 47K 5% 1/10W	
R327	1-216-089-91	METAL GLAZE 47K 5% 1/10W	
R328	1-216-089-91	METAL GLAZE 47K 5% 1/10W	
R331	1-216-053-00	METAL CHIP 1.5K 5% 1/10W	
R332	1-216-053-00	METAL CHIP 1.5K 5% 1/10W	
R333	1-216-053-00	METAL CHIP 1.5K 5% 1/10W	
R334	1-216-053-00	METAL CHIP 1.5K 5% 1/10W	
R335	1-216-097-00	METAL CHIP 100K 5% 1/10W	
R336	1-216-097-00	METAL CHIP 100K 5% 1/10W	
R337	1-216-049-00	METAL CHIP 1K 5% 1/10W	
R338	1-216-049-00	METAL CHIP 1K 5% 1/10W	
R339	1-216-053-00	METAL CHIP 1.5K 5% 1/10W	
R340	1-216-053-00	METAL CHIP 1.5K 5% 1/10W	
R341	1-216-025-00	METAL CHIP 100 5% 1/10W	
R342	1-216-025-00	METAL CHIP 100 5% 1/10W	
R511	1-216-071-00	METAL CHIP 8.2K 5% 1/10W	
R512	1-216-051-00	METAL CHIP 1.2K 5% 1/10W	
R513	1-216-054-00	METAL GLAZE 1.6K 5% 1/10W	
R514	1-216-057-00	METAL CHIP 2.2K 5% 1/10W	
R515	1-216-061-00	METAL CHIP 3.3K 5% 1/10W	
R521	1-216-071-00	METAL CHIP 8.2K 5% 1/10W	
R522	1-216-051-00	METAL CHIP 1.2K 5% 1/10W	
R523	1-216-054-00	METAL GLAZE 1.6K 5% 1/10W	
R524	1-216-057-00	METAL CHIP 2.2K 5% 1/10W	
R525	1-216-061-00	METAL CHIP 3.3K 5% 1/10W	
R526	1-216-067-00	METAL CHIP 5.6K 5% 1/10W	
R527	1-216-074-00	METAL CHIP 11K 5% 1/10W	

MAIN POWER

Ref.No.	Part No.	Description	Remark
R528	1-216-085-00	METAL CHIP	33K 5% 1/10W
R531	1-216-071-00	METAL CHIP	8.2K 5% 1/10W
R532	1-216-051-00	METAL CHIP	1.2K 5% 1/10W
R533	1-216-054-00	METAL GLAZE	1.6K 5% 1/10W
R534	1-216-057-00	METAL CHIP	2.2K 5% 1/10W
R535	1-216-061-00	METAL CHIP	3.3K 5% 1/10W
R536	1-216-067-00	METAL CHIP	5.6K 5% 1/10W
R537	1-216-074-00	METAL CHIP	11K 5% 1/10W
R538	1-216-085-00	METAL CHIP	33K 5% 1/10W
R541	1-216-071-00	METAL CHIP	8.2K 5% 1/10W
R542	1-216-051-00	METAL CHIP	1.2K 5% 1/10W
R543	1-216-054-00	METAL GLAZE	1.6K 5% 1/10W
R544	1-216-057-00	METAL CHIP	2.2K 5% 1/10W
R545	1-216-061-00	METAL CHIP	3.3K 5% 1/10W
R546	1-216-067-00	METAL CHIP	5.6K 5% 1/10W
R547	1-216-074-00	METAL CHIP	11K 5% 1/10W
< VARIABLE RESISTOR >			
RV271	1-223-570-11	RES, VAR, CARBON 1K/1K (PHONE LEVEL)	
< SWITCH >			
S511	1-554-303-21	SWITCH, TACTILE (PEAK SEARCH)	
S512	1-554-303-21	SWITCH, TACTILE (MUSIC SCAN)	
S513	1-554-303-21	SWITCH, TACTILE (FADER)	
S514	1-554-303-21	SWITCH, TACTILE (REPEAT)	
S515	1-554-303-21	SWITCH, TACTILE (TIME)	
S516	1-554-303-21	SWITCH, TACTILE (CONTINUE)	
S517	1-554-303-21	SWITCH, TACTILE (SHUFFLE)	
S518	1-554-303-21	SWITCH, TACTILE (PROGRAM)	
S521	1-554-303-21	SWITCH, TACTILE (10)	
S522	1-554-303-21	SWITCH, TACTILE (9)	
S523	1-554-303-21	SWITCH, TACTILE (8)	
S524	1-554-303-21	SWITCH, TACTILE (7)	
S525	1-554-303-21	SWITCH, TACTILE (6)	
S526	1-554-303-21	SWITCH, TACTILE (CHECK)	
S527	1-554-303-21	SWITCH, TACTILE (CLEAR)	
S528	1-554-303-21	SWITCH, TACTILE (>10)	
S531	1-554-303-21	SWITCH, TACTILE (5)	
S532	1-554-303-21	SWITCH, TACTILE (4)	
S533	1-554-303-21	SWITCH, TACTILE (3)	
S534	1-554-303-21	SWITCH, TACTILE (2)	
S535	1-554-303-21	SWITCH, TACTILE (1)	
S541	1-554-303-21	SWITCH, TACTILE (△ OPEN/CLOSE)	
S542	1-554-303-21	SWITCH, TACTILE (▷)	
S543	1-554-303-21	SWITCH, TACTILE (▣)	
S544	1-554-303-21	SWITCH, TACTILE (■)	
S545	1-554-303-21	SWITCH, TACTILE (⏏ ⏏)	
S546	1-554-303-21	SWITCH, TACTILE (▶ ▶)	

Ref.No.	Part No.	Description	Remark
S547	1-554-303-21	SWITCH, TACTILE (EDIT/TIME FADE)	
< VIBRATOR >			
X201	1-577-082-11	VIBRATOR, CERAMIC (4 MHz)	
X301	1-579-833-21	VIBRATOR, CRYSTAL (33.8 MHz) (215)	
X301	1-579-834-11	VIBRATOR, CRYSTAL (33.8 MHz) (315)	

*	1-651-265-11	POWER BOARD	

< CAPACITOR >			
C281	1-162-291-31	CERAMIC	560PF 10% 50V
C282	1-162-291-31	CERAMIC	560PF 10% 50V
C283	1-164-159-11	CERAMIC	0.1uF 50V (315)
C284	1-136-165-00	FILM	0.1uF 5% 50V (315)
C285	1-126-934-11	ELECT	220uF 20% 16V (315)
C901	1-126-768-11	ELECT	2200uF 20% 16V (215)
C901	1-124-894-11	ELECT	6800uF 20% 16V (315)
C902	1-126-939-11	ELECT	10000uF 20% 16V
C903	1-124-572-11	ELECT	100uF 20% 63V (MADE IN CHINA)
C903	1-128-576-11	ELECT	100uF 20% 63V (MADE IN FRANCE)
C904	1-164-159-11	CERAMIC	0.1uF 50V
C905	1-164-159-11	CERAMIC	0.1uF 50V
C906	1-164-159-11	CERAMIC	0.1uF 50V
C907	1-164-159-11	CERAMIC	0.1uF 50V
C908	1-164-159-11	CERAMIC	0.1uF 50V
< CONNECTOR >			
CN281	1-506-469-11	PIN, CONNECTOR	4P
CN901	1-506-468-11	PIN, CONNECTOR	3P
CN902	1-506-468-11	PIN, CONNECTOR	3P (215)
△CN903	1-580-230-11	PIN, CONNECTOR (PC BOARD)	
< DIODE >			
D901	8-719-200-82	DIODE	11ES2
D902	8-719-200-82	DIODE	11ES2
D903	8-719-200-82	DIODE	11ES2
D904	8-719-200-82	DIODE	11ES2
D905	8-719-200-82	DIODE	11ES2
< IC >			
IC281	8-749-921-12	IC	GP1F32T (DIGITAL OUT) (315)

The components identified by mark △ or dotted line with mark △ are critical for safety. Replace only with part number specified.

POWER

POWER SW

HP

Ref.No.	Part No.	Description	Remark
		< JACK >	
J281	1-750-679-21	JACK, PIN 2P (LINE OUT)	
		< COIL >	
L901	1-412-473-21	INDUCTOR 0uH (315)	
L902	1-412-473-21	INDUCTOR 0uH (315)	
		< SWITCH >	
△S901	1-572-675-11	SWITCH, POWER VOLTAGE, CHANGE (VOLTAGE SELECTOR) (315:E)	
		< TRANSFORMER >	
△T901	1-426-621-11	TRANSFORMER, POWER (215:US, /315:US)	
△T901	1-423-979-11	TRANSFORMER, POWER (215:AEP, EE/ 315:AEP, G, EE, AUS)	
△T901	1-423-622-11	TRANSFORMER, POWER (315:E)	

*	1-651-266-11	POWER SW BOARD *****	
		< CONNECTOR >	
CN291	1-506-469-11	PIN, CONNECTOR 4P	
		< SWITCH >	
S291	1-554-118-00	SWITCH, PUSH (1 KEY) (POWER)	

*	1-651-267-11	HP BOARD *****	
		< CAPACITOR >	
C275	1-162-291-31	CERAMIC 560PF 10% 50V	
C276	1-162-291-31	CERAMIC 560PF 10% 50V	
C277	1-164-159-11	CERAMIC 0.1uF 50V	
		< CONNECTOR >	
*CN271	1-568-941-11	PIN, CONNECTOR 3P	
		< JACK >	
J271	1-568-519-41	JACK, LARGE TYPE (PHONES)	
		< COIL >	
L271	1-412-473-21	INDUCTOR 0uH (MADE IN CHINA)	
L271	1-410-397-21	FERRITE BEAD INDUCTOR (MADE IN FRANCE)	
L272	1-412-473-21	INDUCTOR 0uH (MADE IN CHINA)	
L272	1-410-397-21	FERRITE BEAD INDUCTOR (MADE IN FRANCE)	
L273	1-412-473-21	INDUCTOR 0uH (MADE IN CHINA)	
L273	1-410-397-21	FERRITE BEAD INDUCTOR (MADE IN FRANCE)	

Ref.No.	Part No.	Description	Remark
		MISCELLANEOUS *****	
△21	1-569-007-11	ADAPTER, CONVERSION 2P	
△22	1-575-651-21	CORD, POWER (AEP, G, EE)	
△23	1-696-845-11	CORD, POWER (315:AUS)	
△24	1-569-007-11	ADAPTER, CONVERSION 2P (315:E)	
△25	1-558-943-41	CORD, POWER (315:E)	
△26	1-590-926-11	CORD, POWER (US)	
*61	1-452-538-11	MAGNET	
△105	8-848-144-11	DEVICE, OPTICAL KSS-240A	
108	1-575-001-11	WIRE, FLAT TYPE (12 CORE)	
CNP101	1-537-472-11	JUMPER, FILM (WITH TERMINAL)	
M101	X-4917-523-3	MOTOR ASSY (SPINDLE)	
M102	X-4917-504-1	MOTOR ASSY (SLED)	
M151	A-4604-363-A	MOTOR (L) ASSY (LOADING)	

		ACCESSORIES & PACKING MATERIALS *****	
	1-467-316-11	REMOTE COMMANDER (RM-D320) (315)	
	1-558-271-11	CORD, CONNECTION (AUDIO)	
	3-757-991-11	MANUAL, INSTRUCTION (ENGLISH/FRENCH/SPANISH/CHINESE) (215:AEP/315:AEP, E, AUS) (MADE IN CHINA)	
	3-757-991-21	MANUAL, INSTRUCTION (ENGLISH) (US)	
	3-757-991-41	MANUAL, INSTRUCTION (GERMAN/ITALIAN/DUTCH/PORTUGUESE) (AEP) (MADE IN CHINA)	
	3-757-991-51	MANUAL, INSTRUCTION (ENGLISH/FRENCH/SPANISH) (AEP) (MADE IN FRANCE)	
	3-757-991-61	MANUAL, INSTRUCTION (GERMAN/ITALIAN/DUTCH/PORTUGUESE) (AEP) (MADE IN FRANCE)	
	3-757-991-71	MANUAL, INSTRUCTION (GERMAN) (G)	
	3-757-991-81	MANUAL, INSTRUCTION (EE)	
	3-757-991-91	MANUAL, INSTRUCTION (SWEDISH/FRENCH/ITALIAN) (AEP)	
*	4-925-389-11	CUSHION (215:US, AEP, EE/315:US, AEP, E, EE, AUS) (MADE IN CHINA)	
*	4-929-506-01	CUSHION (215:AEP/315:AEP, G) (MADE IN FRANCE)	
*	4-955-659-41	INDIVIDUAL CARTON (215:AEP) (MADE IN FRANCE)	
*	4-955-659-51	INDIVIDUAL CARTON (315:AEP, G) (MADE IN FRANCE)	
*	4-962-615-01	COVER, BATTERY (RM-320) (315)	
*	4-964-737-01	INDIVIDUAL CARTON (215:US)	
*	4-964-737-11	INDIVIDUAL CARTON (215:AEP, EE) (MADE IN CHINA)	
*	4-964-737-21	INDIVIDUAL CARTON (315:US, E, AUS)	
*	4-964-737-31	INDIVIDUAL CARTON (315:AEP, EE) (MADE IN CHINA)	

The components identified by mark △ or dotted line with mark △ are critical for safety. Replace only with part number specified.

<u>Ref.No.</u>	<u>Part No.</u>	<u>Description</u>	<u>Remark</u>
----------------	-----------------	--------------------	---------------

HARDWARE LIST

#1	7-621-775-10	SCREW +B 2.6X4	
#2	7-621-255-15	SCREW +P 2X3	
#3	7-682-547-09	SCREW +BVTT 3X6 (S)	
#4	7-682-548-04	SCREW +B 3X8	
#5	7-685-872-01	SCREW +BVTT 3X8 CZN	
#6	7-685-646-79	SCREW +BVTP 3X8 TYPE2 N-S	