

CDP-261/361

SERVICE MANUAL

US Model
AEP Model
CDP-261/361

UK Model
E Model
Australian Model
CDP-361

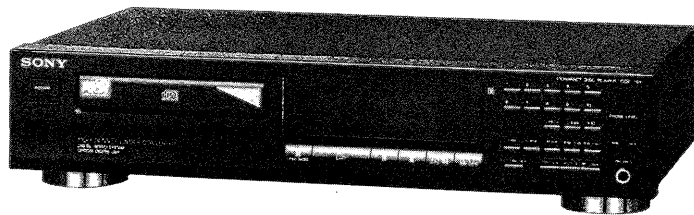

Photo : CDP-361

Model Name Using Similar Mechanism	CDP-212/312
CD Mechanism Type	CDM14-5BD10
Base Unit Type	BU-5BD10B
Optical Pick-up Type	KSS-240A

SPECIFICATIONS

Compact disc player

Laser	Semiconductor laser
Wavelength	780 – 790 nm
Frequency response	2 Hz to 20 kHz \pm 0.5 dB
Signal-to-noise ratio	More than 100 dB
Dynamic range	More than 98 dB
Harmonic distortion	Less than 0.0045%
Channel separation	More than 95 dB

Outputs

	Jack type	Maximum output level	Load impedance
LINE OUT (VARIABLE) (CDP-361)	Phono jacks	2 V (at 50 kilohms)	Over 10 kilohms
LINE OUT (CDP-261)	Phono jacks	2 V (at 50 kilohms)	Over 10 kilohms
DIGITAL OUT (OPTICAL) (CDP-361)	Optical output connector	-18 dBm	Wave length: 660 nm
PHONES	Stereo phone jack	10 mW	32 ohms

General

Power requirements	US model : 120 V AC, 60 Hz European model : 220 – 230 V AC, 50/60 Hz Australian model : 240 V AC, 60 Hz Models for other countries : 110 – 120/220 – 240 V AC, Adjustable, 50/60 Hz
--------------------	---

Power consumption	10 W
Dimensions (approx.) (w/h/d)	430 × 100 × 295 mm (17 × 4 × 11 5/8 in.) incl. projecting parts
Mass (approx.)	3.2 kg (7 lbs 1 oz)

Supplied accessories

Audio cord (2 phono plugs – 2 phono plugs) (1)
Remote commander (remote) (CDP-361 only) (1)
Sony SUM-3 (NS) batteries (CDP-361 only) (2)

Design and specifications are subject to change without notice.



COMPACT DISC PLAYER
SONY®

SAFETY CHECK-OUT

After correcting the original service problem, perform the following safety checks before releasing the set to the customer:

Check the antenna terminals, metal trim, "metallized" knobs, screws, and all other exposed metal parts for AC leakage. Check leakage as described below.

LEAKAGE

The AC leakage from any exposed metal part to earth ground and from all exposed metal parts to any exposed metal part having a return to chassis, must not exceed 0.5 mA (500 microamperes). Leakage current can be measured by any one of three methods.

1. A commercial leakage tester, such as the Simpson 229 or RCA WT-540A. Follow the manufacturers' instructions to use these instruments.
2. A battery-operated AC milliammeter. The Data Precision 245 digital multimeter is suitable for this job.
3. Measuring the voltage drop across a resistor by means of a VOM or battery-operated AC voltmeter. The "limit" indication is 0.75 V, so analog meters must have an accurate low-voltage scale. The Simpson 250 and Sanwa SH-63Trd are examples of a passive VOM that is suitable. Nearly all battery operated digital multimeters that have a 2V AC range are suitable. (See Fig. A)

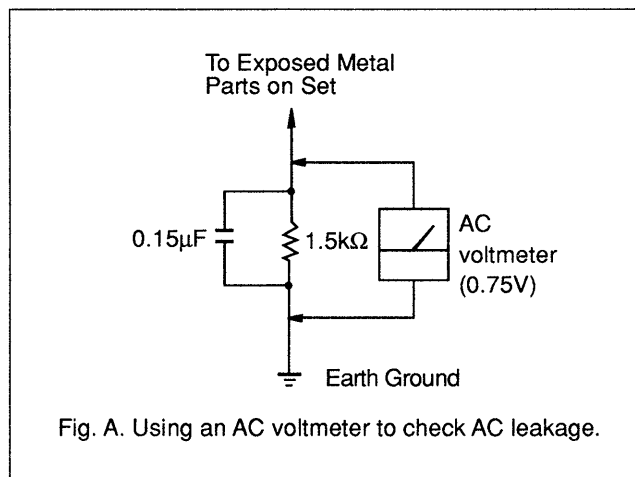

SAFETY-RELATED COMPONENT WARNING !!

COMPONENTS IDENTIFIED BY MARK Δ OR DOTTED LINE WITH MARK Δ ON THE SCHEMATIC DIAGRAMS AND IN THE PARTS LIST ARE CRITICAL TO SAFE OPERATION. REPLACE THESE COMPONENTS WITH SONY PARTS WHOSE PART NUMBERS APPEAR AS SHOWN IN THIS MANUAL OR IN SUPPLEMENTS PUBLISHED BY SONY.

TABLE OF CONTENTS

<u>Section</u>	<u>Title</u>	<u>Page</u>
1.	GENERAL	4
2.	DISASSEMBLY	
2-1.	Front Panel	5
2-2.	Base Unit Block	5
3.	ELECTRICAL BLOCK CHECKING	6
4.	DIAGRAMS	
4-1.	IC Pin Functions	
	• IC101 Digital Servo Digital Signal Processor (CXD2515Q)	8
	• IC201 Master Control (CXP82612-007Q)	10
4-2.	Block Diagram	12
4-3.	Semiconductor Lead Layouts	15
4-4.	Circuit Boards Location	15
4-5.	Printed Wiring Board	16
4-6.	Schematic Diagram	19
5.	EXPLODED VIEWS	
5-1.	Case Section	23
5-2.	Back Panel Section	24
5-3.	CD Mechanism Section (CDM14-5BD10)	25
5-4.	Base Unit Section (BU-5BD10B)	26
6.	ELECTRICAL PARTS LIST	27

MODEL IDENTIFICATION

— BACK PANEL —

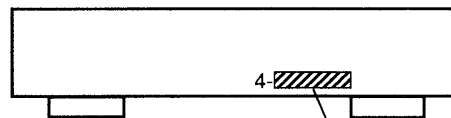

CDP-261	
US Model	: 969-747-4□
AEP, East European Model	: 969-743-1□
German Model	: 969-743-9□
CDP-361	
US Model	: 969-747-0□
AEP, East European Model	: 969-743-0□
(made in FRANCE)	
AEP Model	: 969-747-1□
(made in CHINA)	
UK Model	: 971-521-1□
German Model	: 969-743-8□
E Model	: 969-747-2□
E Model	: 969-747-3□
(made in CHINA)	
Australian Model	: 973-614-0□

SERVICING NOTE

NOTES ON HANDLING THE OPTICAL PICK-UP BLOCK OR BASE UNIT

The laser diode in the optical pick-up block may suffer electrostatic break-down because of the potential difference generated by the charged electrostatic load, etc. on clothing and the human body.

During repair, pay attention to electrostatic break-down and also use the procedure in the printed matter which is included in the repair parts.

The flexible board is easily damaged and should be handled with care.

NOTES ON LASER DIODE EMISSION CHECK

The laser beam on this model is concentrated so as to be focused on the disc reflective surface by the objective lens in the optical pick-up block. Therefore, when checking the laser diode emission, observe from more than 30 cm away from the objective lens.

LASER DIODE AND FOCUS SEARCH OPERATION CHECK

1. Turn POWER switch on with no disc inserted and disc table closed.
2. Confirm that the following operation is performed while observing the objective lens.

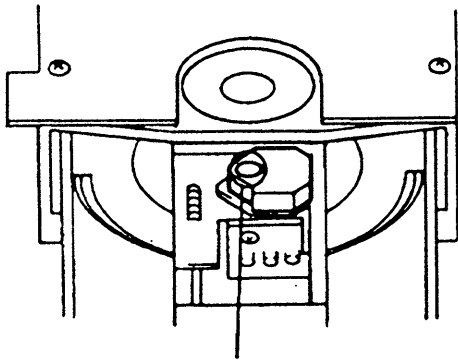

- ① Confirm that laser beam is spread.
- ② Up and down motion of the objective lens. (3 times)

The laser component in this product is capable of emitting radiation exceeding the limit for Class 1.

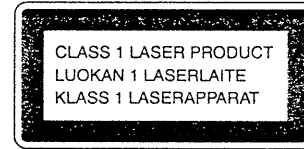

This appliance is classified as a CLASS 1 LASER product. The CLASS 1 LASER PRODUCT MARKING is located on the rear exterior.

The following caution label is located inside of the unit.

CAUTION	: INVISIBLE LASER RADIATION WHEN OPEN AND/OR EXPOSURE TO SKIN
ADVARSEL	: USYNLIG LASERSTRÅLING VED ÅBNING NÅR DRIVESVITSENBRYDERE ER LØST AF PLAKEN (UNDGÅ UDSÆTTELSE FOR STRÅLING)
VARO!	: AVIATAMINEN JA "LOJALUUTUS OHIETÄLLISSÄ" KÄYTTÄ KÄYTTÄ LASERLAITTELLA
VARNING	: LASERSTRÅLING NÅR SKIVAN OCH/ OCH ONSKAD OCH SPÄRRING ÄR UTSKOPPLAD
ADVARSEL	: USYNLIG LASERSTRÅLING NÅR ONSKED ÅPNES UNDER TILDRIFNING FOR STRÅLING

CAUTION

Use of controls or adjustments or performance of procedures other than those specified herein may result in hazardous radiation exposure.

SECTION 1 GENERAL

This section is extracted from instruction manual.

CDP-261/361

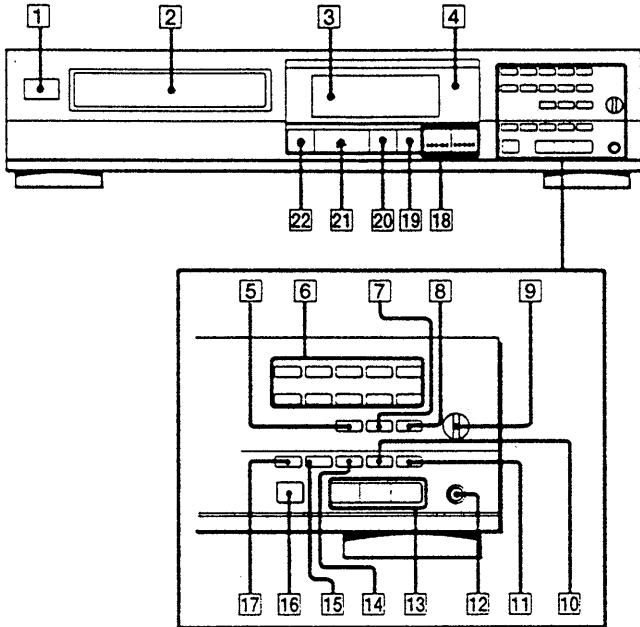

RM-D420

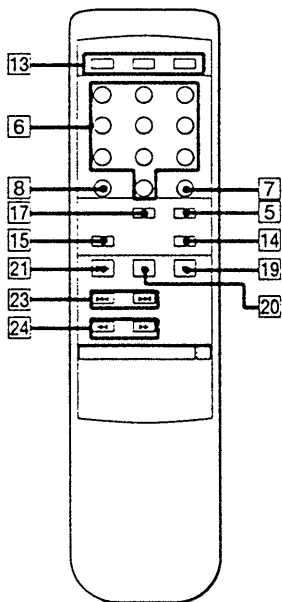

(only for CDP-361)

Identifying the Parts

Refer to the pages indicated in parenthesis for details.

Front Panel / Remote Commander

- 1 POWER switch
- 2 Disc tray
- 3 Display
- 4 Remote sensor
- 5 CHECK (program check) button
- 6 Numeric buttons
- 7 CLEAR (program clear) button
- 8 >10 (over 10) button
- 9 PHONE LEVEL control
- 10 MUSIC SCAN button
- 11 PEAK SEARCH button
- 12 PHONES jack
- 13 Play Mode buttons
CONTINUE button
SHUFFLE button
PROGRAM button
- 14 FADER button
- 15 REPEAT button
- 16 EDIT/TIME FADE button
- 17 TIME button
- 18 <<< / >>> (AMS*/manual search) buttons
- 19 ■ (stop) button
- 20 || (pause) button
- 21 ▷ (play) button
- 22 ⏏ OPEN/CLOSE button
- 23 <<< / >>> (AMS*) buttons
(Only on the remote commander)
- 24 <<< / >>> (manual search)
(Only on the remote commander)

* AMS is the abbreviation of Automatic Music Sensor.

SECTION 2 DISASSEMBLY

Note : Follow the disassembly procedure in the numerical order given.

3-1. FRONT PANEL

• When removing the front panel assembly on electric power failure, first open the loading block by turning cam with a screwdriver as shown in the figure, next pull out the loading block with hand, and remove the loading panel as shown in the figure, Then remove the front panel assembly.

③ Remove loading panel in the arrow direction.

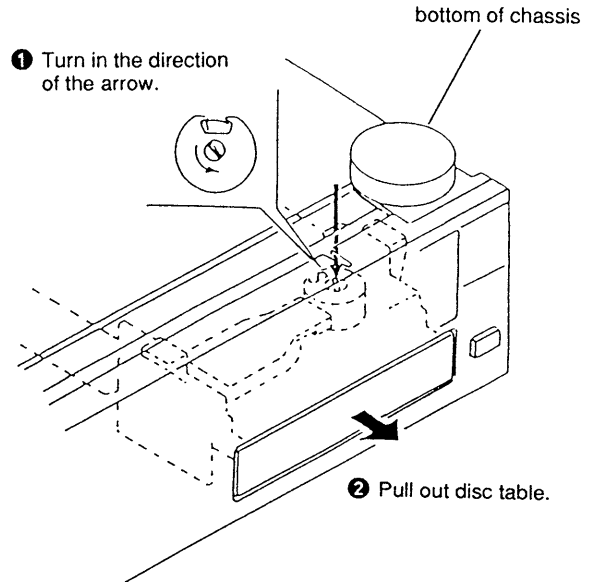
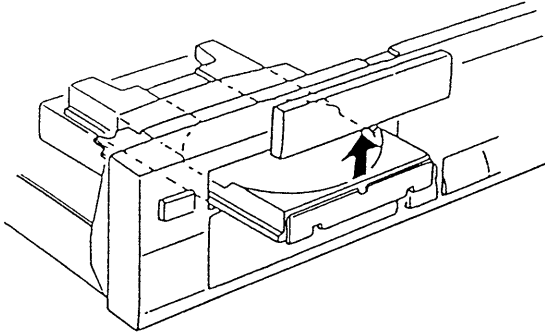

3-2. BASE UNIT BLOCK

- ① Turn the cam to the direction of arrow (Counter clock wise) by minus screw driver.
- ② Take off the disc table.
- ③ Remove the yoke bracket.
- ④ Remove the MD (BU-5BD10B) to the direction of arrow.

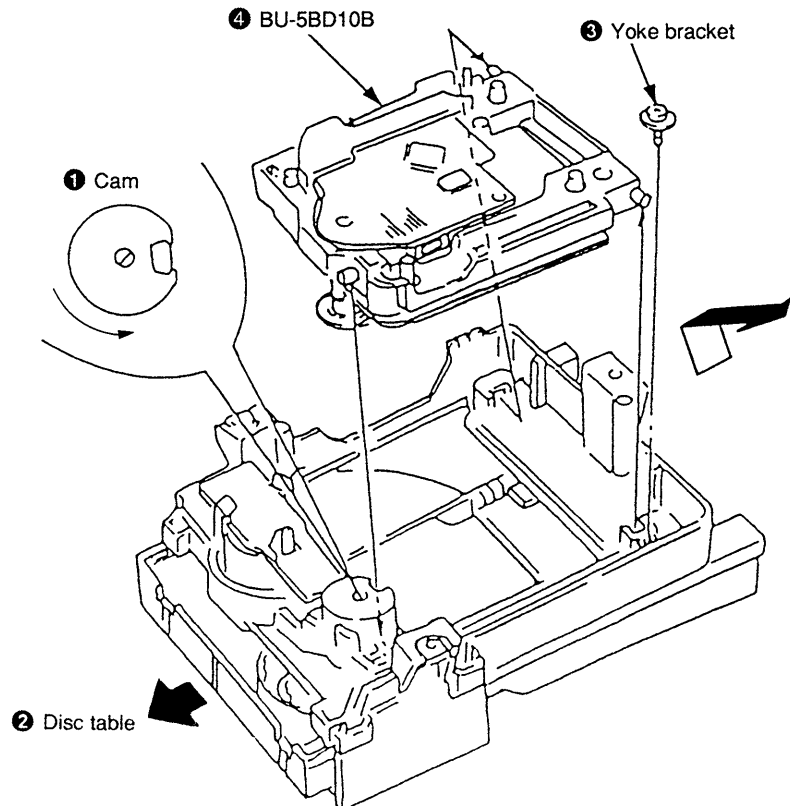

SECTION 3

ELECTRICAL BLOCK CHECKING

Note :

1. CD Block is basically constructed to operate without adjustment. Therefore, check each item in order given.
2. Use YEDS-18 disc (3-702-101-01) unless otherwise indicated.
3. Use an oscilloscope with more than 10MΩ impedance.
4. Clean an object lens by an applicator with neutral detergent when the signal level is low than specified value with the following checks.

S Curve Check

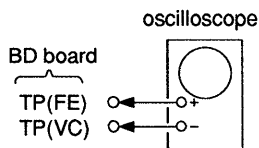

Procedure :

1. Connect oscilloscope to test point TP (FE) on BD board.
2. Connect between test point TP (TEI) and TP (VC) by lead wire.
3. Turned Power switch on.
4. Put disc (YEDS-18) in and turned Power switch on again and actuate the focus search. (actuate the focus search when disc table is moving in and out.)
5. Check the oscilloscope waveform (S-curve) is symmetrical between A and B. And confirm peak to peak level within 3 ± 1 Vp-p.

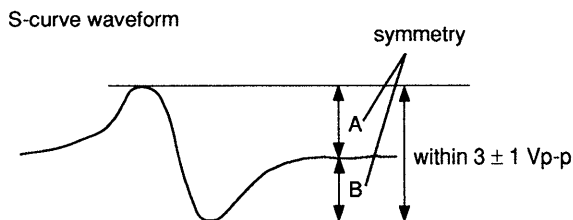

6. After check, remove the lead wire connected in step 2.

Note :

- Try to measure several times to make sure that the ratio of A : B or B : A is more than 10 : 7.
- Take sweep time as long as possible and light up the brightness to obtain best waveform.

RF Level Check

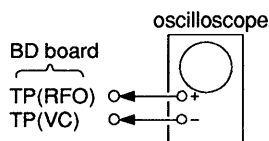

Procedure :

1. Connect oscilloscope to test point TP (RFO) on BD board.
2. Turned Power switch on.

3. Put disc (YEDS-18) in and playback.
4. Confirm that oscilloscope waveform is clear and check RF signal level is correct or not.

Note :

Clear RF signal waveform means that the shape “◇” can be clearly distinguished at the center of the waveform.

RF signal waveform

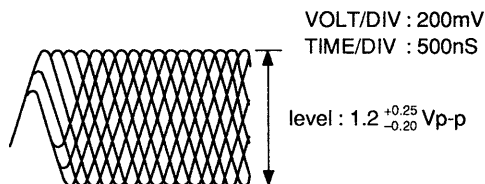

E-F Balance Check

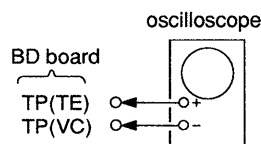

Procedure :

1. Connect test point TP (ADJ) to ground and TP(FEI) to TP (VC) with a lead wire.
2. Connect oscilloscope to test point TP (TE) on BD board.
3. Turned Power switch on.
4. Put disc (YEDS-18) in and playback.
5. Confirm that the oscilloscope waveform is symmetrical on the top and bottom in relation to 0V, and check this level.

Traverse waveform



6. Remove the lead wire connected in step 1.

RF PLL Free-run Frequency Check

Procedure :

1. Connect frequency counter to test point (PCLK) with lead wire.

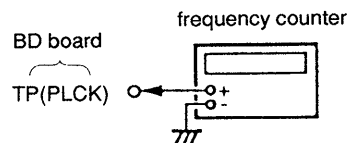

2. Turned Power switch on.
3. Confirm that reading on frequency counter is 4.3218MHz.

Adjustment Location :

[BD BOARD]

— Conductor side —

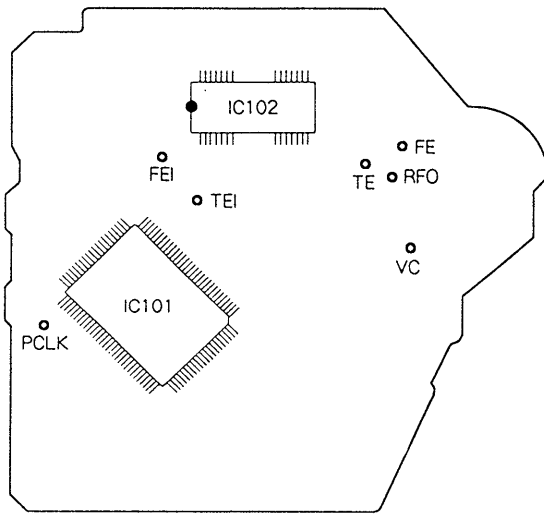

[MAIN BOARD]

— Conductor side —

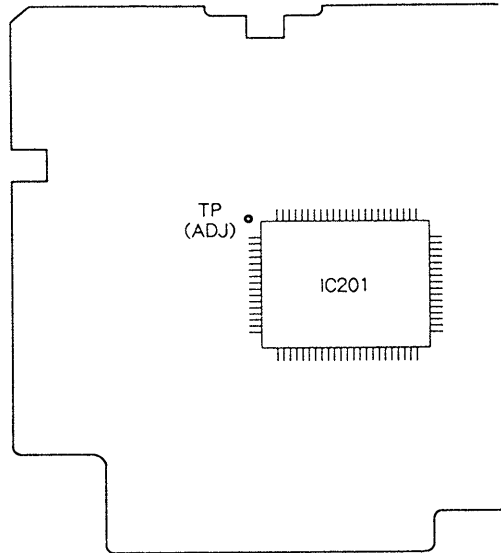

SECTION 4 DIAGRAMS

4-1. IC PIN FUNCTIONS

• IC101 DIGITAL SERVO & DIGITAL SIGNAL PROCESSOR (CXD2515Q)

Pin No.	Pin Name	I/O	Function
1	SRON	O	Sled drive output
2	SRDR	O	Sled drive output
3	SFON	O	Sled drive output
4	TFDR	O	Tracking drive output
5	TRON	O	Tracking drive output
6	TRDR	O	Tracking drive output
7	TFON	O	Tracking drive output
8	FFDR	O	Focus drive output
9	FRON	O	Focus drive output
10	FRDR	O	Focus drive output
11	FFON	O	Focus drive output
12	VCOO	O	VCO output for analog EFM PLL
13	VCOI	I	VCO output for analog EFM PLL
14	TEST	I	TEST pin connected normally to GND
15	DVss	—	Digital GND
16	TES2	I	TEST pin connected normally to GND
17	TES3	I	TEST pin connected normally to GND
18	PDO	O	Charge-pump output for analog EFM PLL
19	VPCO	O	Charge-pump output for variable pitch PLL
20	VCKI	I	Clock input from variable pitch external VCO
21	AVD2	—	Analog power supply
22	IGEN	I	Power supply pin for operational amplifiers
23	AVS2	—	Analog GND
24	ADII	I	Input pin for A/D converter
25	ADIO	O	Operational amplifier output pin
26	RFDC	I	RF signal input
27	TE	I	Tracking error signal input
28	SE	I	Sled error signal input
29	FE	I	Focus error signal input
30	VC	I	Center voltage input pin
31	FILO	O	Filter output for master PLL
32	FILI	I	Filter input for master PLL
33	PCO	O	Charge-pump output for master PLL
34	CLTV	I	Control voltage input for master VCO
35	AVS1	—	Analog GND
36	RFAC	I	EFM signal input
37	BIAS	I	Asymmetry circuit constant current input
38	ASY1	I	Asymmetry compare voltage input
39	ASYO	O	EFM full swing output
40	AVD1	—	Analog power supply

Pin No.	Pin Name	I/O	Function
41	DVDD	–	Digital power supply
42	ASYE	I	Asymmetry circuit ON/OFF
43	PSSL	I	Audio data output mode selection input
44	WDCK	O	48-bit slot D/A interface. Word clock
45	LRCK	O	48-bit slot D/A interface. LR clock
46	DATA	O	DA 16 output when PSSL=1. 48-bit slot serial data when PSSL=0
47	BCLK	O	DA 15 output when PSSL=1. 48-bit slot data when PSSL=0
48	64DATA	O	DA 14 output when PSSL=1. 64-bit slot data when PSSL=0
49	64BCLK	O	DA 13 output when PSSL=1. 64-bit slot data when PSSL=0
50	64LRCK	O	DA 12 output when PSSL=1. 64-bit slot data when PSSL=0
51	GTOP	O	DA 11 output when PSSL=1. GTOP output when PSSL=0
52	XUGF	O	DA 10 output when PSSL=1. XUGF output when PSSL=0
53	XPLCK	O	DA 09 output when PSSL=1. XPLCK output when PSSL=0
54	GFS	O	DA 08 output when PSSL=1. GFS output when PSSL=0
55	PFCK	O	DA 07 output when PSSL=1. RFCK output when PSSL=0
56	C2PO	O	DA 06 output when PSSL=1. C2PO output when PSSL=0
57	XRAOF	O	DA 05 output when PSSL=1. XRAOF output when PSSL=0
58	MNT3	O	DA 04 output when PSSL=1. MNT3 output when PSSL=0
59	MNT2	O	DA 03 output when PSSL=1. MNT2 output when PSSL=0
60	MNT1	O	DA 02 output when PSSL=1. MNT1 output when PSSL=0
61	MNT0	O	DA 01 output when PSSL=1. MNT0 output when PSSL=0
62	XTAI	I	X'tal oscillator circuit input
63	XTAO	O	X'tal oscillator circuit output
64	XTSL	I	X'tal selection input pin
65	DVss	–	Digital GND
66	FSTI	I	2/3 divider output of pins 62, 63
67	FSTO	O	2/3 divider output of pins 62, 63
68	C4M	O	4.2336 MHz output
69	C16M	O	16.9344 MHz output
70	MD2	I	Digital-out ON/OFF control pin
71	DOUT	O	Digital-out output pin
72	EMPH	O	Playback disc output in emphasis mode
73	WFCK	O	WFCK output
74	SCOR	O	Sub-code sync output
75	SBSO	O	Sub-P through Sub-W serial output
76	EXCK	I	Clock input for SBS0 read-out
77	SUBQ	O	Sub-Q 80-bit output
78	SQCK	I	Clock input for SQS0 read-out
79	MUTE	I	Muting selection pin
80	SENS	O	SENS output
81	XRST	I	System reset
82	DIRC	I	Used in 1-track jump mode
83	SCLK	I	SENS serial data read-out clock
84	DFSW	I	DFCT selection pin
85	ATSK	I	Input pin for anti-shock

Pin No.	Pin Name	I/O	Function
86	DATA	I	Serial data input, supplied from CPU
87	XLAT	I	Latch input, supplied from CPU
88	CLOK	I	Serial data transfer clock input, supplied from CPU
89	COUT	O	Numbers of track counted signal output
90	DVDD	—	Digital power supply
91	MIRR	O	Mirror signal output
92	DFCT	O	Defect signal output
93	FOK	O	Focus OK output
94	FSW	O	Output to select spindle motor output filter
95	MON	O	Output to control ON/OFF of spindle motor
96	MDP	O	Output to control spindle motor servo
97	MDS	O	Output to control spindle motor servo
98	LOCK	O	GFS is sampled by 460 Hz. H when GFS is H
99	SSTP	I	Input signal to detect disc inner most track
100	SFDR	O	Sled drive output

• IC201 MASTER CONTROL (CXP82612-007Q)

Pin No.	Pin Name	I/O	Function
1	TIMER	—	Connected to +5V.
2	RM	I	Audio bus input.
3	+5V	—	Connected to +5V.
4	OPEN	—	} Not used. (open).
5	OPEN	—	
6	OPEN	—	
7	PGML	O	Latch signal output to digital filter (IC301).
8	CLK	O	Serial clock output.
9	SENSE	I	SENSE signal input.
10	DATA	O	Serial data output.
11	SQCK	O	Read out clock output for subcode Q data.
12	SUBQ	I	Subcode Q data input.
13	OPEN	—	Not used. (open)
14	AMUTE	O	Analog muting control signal output.
15	LDON	O	Optical pickup laser diode control output.
16	XLT	O	Serial data latch signal output.
17	OPEN	—	} Not used. (open).
18	RV+	—	
19	RV-	—	
20	LDOUT	O	} Loading motor control signal output.
21	LDIN	O	
22, 23	KEY0, KEY1	I	Key input. (S601 to S612)
24 to 27	KEY2 to KEY5	—	Connected to +5V.
28	ADJ/AFADJ	—	ADJ, AFJ test pin.
29	IN/OUTSW	I	Loading IN/OUT switch input.
30	RST	I	Reset signal input.
31	EXTAL	I	Clock input. (4 MHz)
32	XTAL	O	Clock output. (4 MHz)
33	V _{ss}	—	GND
34 to 41	OPEN	—	Not used. (open)
42 to 62	S1 to S21	O	FL segment output.
63 to 70	1G to 7G	O	FL grid output.
71	VFDP (-30V)	—	-30V pin for FL display tube.
72	V _{DD} (+5V)	—	} +5V pin.
73	—	—	
74	SEL1	—	} Connected to GND.
75	OPEN	—	
76	OPEN	—	
77	OPEN	—	
78	SCOR	I	Read out timing signal input for subcode Q data.
79	SEL2	—	Connected to GND.
80	SEL3	—	Connected to +5V.

4-2. BLOCK DIAGRAM

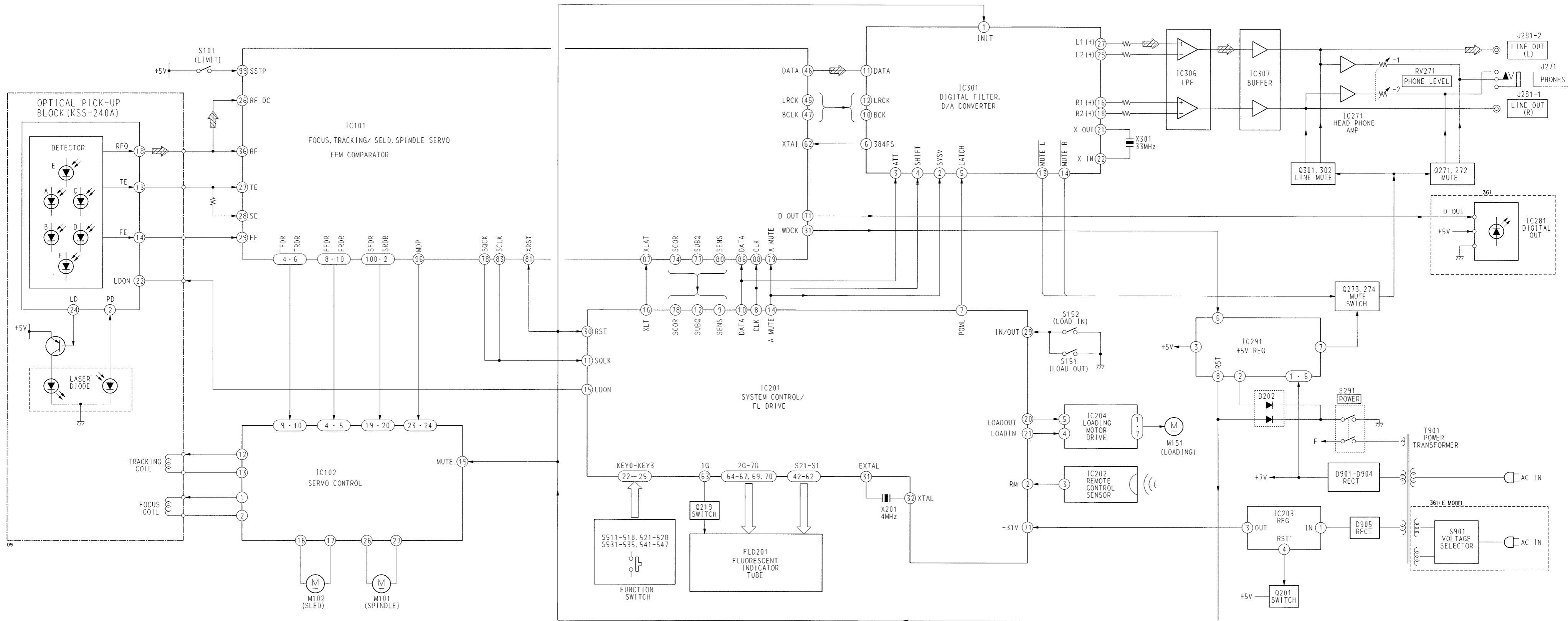

• Signal path.
 ⇨ : CD

4-3. SEMICONDUCTOR LEAD LAYOUTS

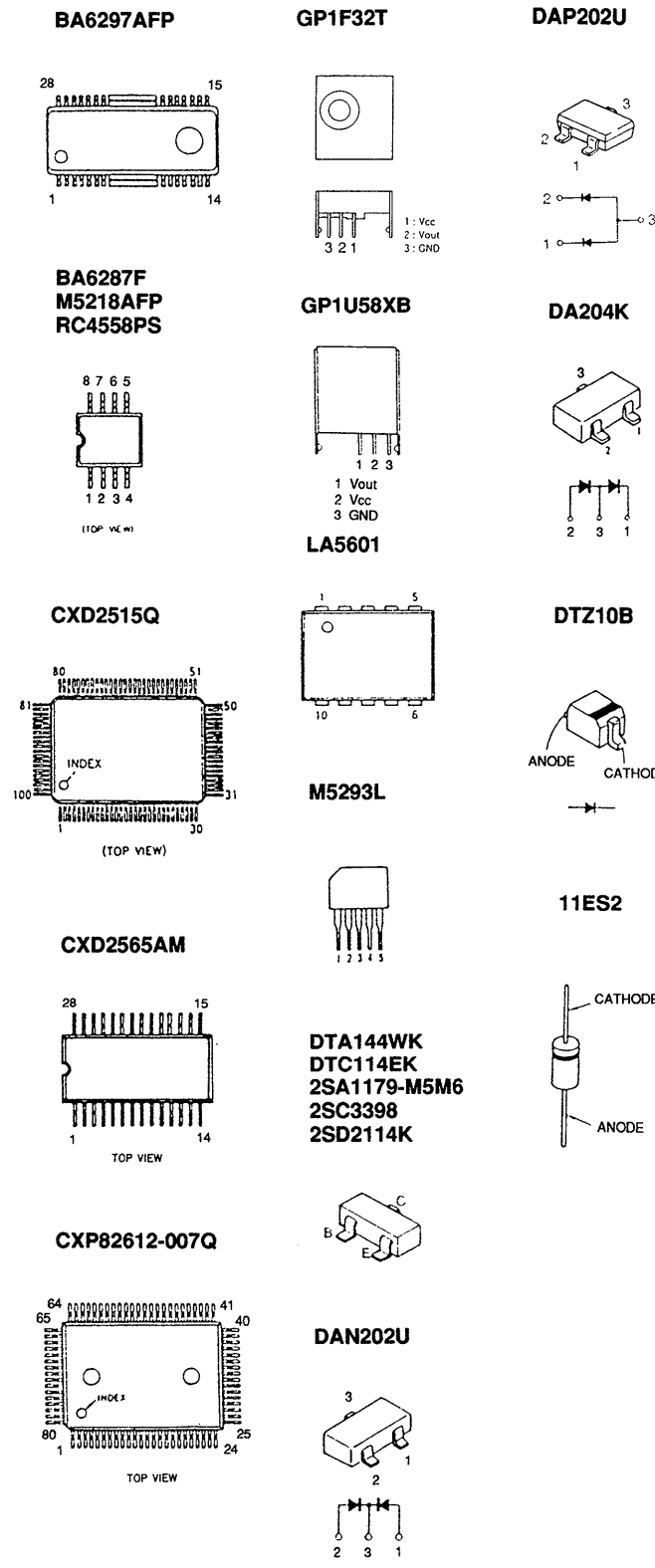

4-4. CIRCUIT BOARDS LOCATIONS

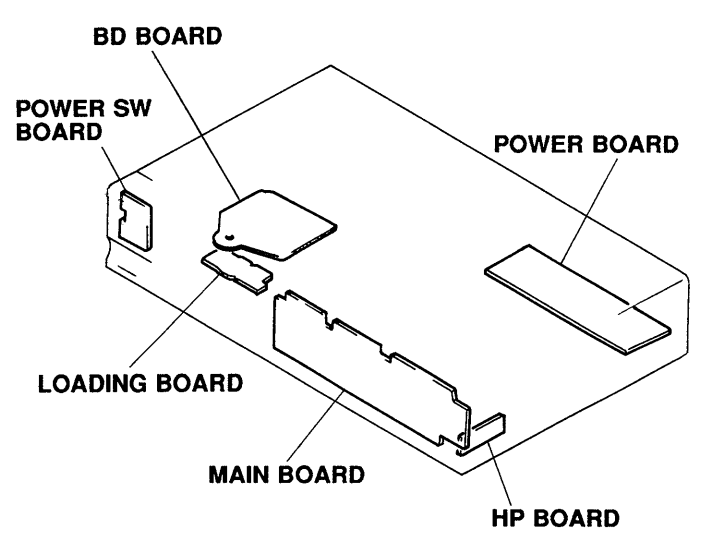

4-5. PRINTED WIRING BOARD

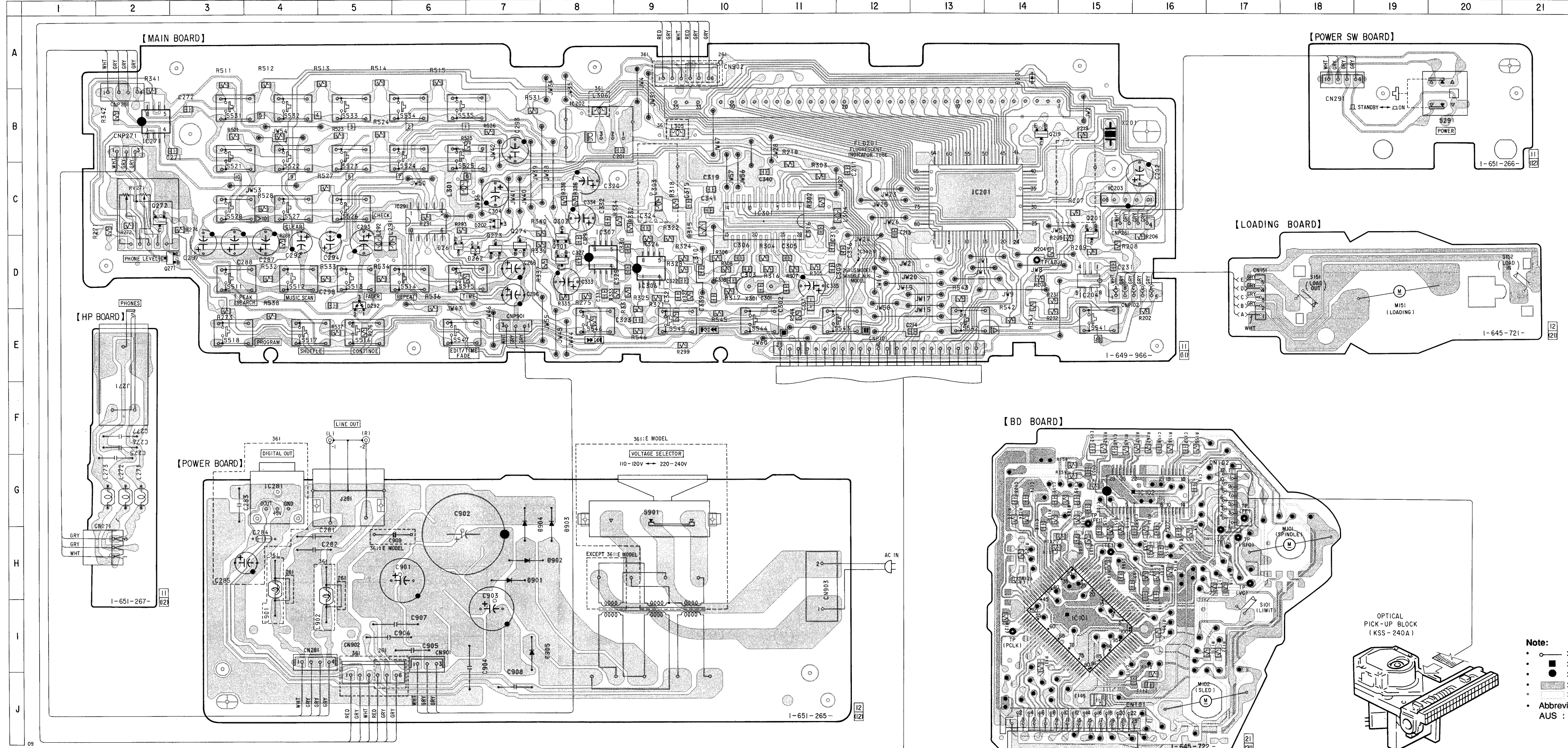

• Semiconductor Location

Ref. No.	Location
D201	A - 14
D202	C - 7
D261	D - 6
D262	D - 7
D292	D - 5
D901	H - 7
D902	H - 7
D903	H - 8
D904	H - 7
D905	I - 7
IC101	I - 15
IC102	G - 16
IC201	B - 8
IC202	B - 8
IC203	C - 15
IC204	C - 15
IC271	B - 2
IC281	G - 4
IC291	C - 6
IC301	C - 10
IC306	D - 9
IC307	D - 8
Q201	D - 15
Q219	B - 14
Q271	D - 2
Q272	C - 2
Q273	D - 7
Q274	D - 7
Q301	D - 8
Q302	D - 8

Note:
 ○ : parts extracted from the component side.
 ● : parts mounted on the conductor side.
 ■ : Through hole.
 ▨ : Pattern from the side which enable seeing.
 ▩ : Pattern of the rear side.
 • Abbreviation
 AUS : Australian model.

4-6. SCHEMATIC DIAGRAM
See page 8 for IC Pin Functions. (IC101, IC201)

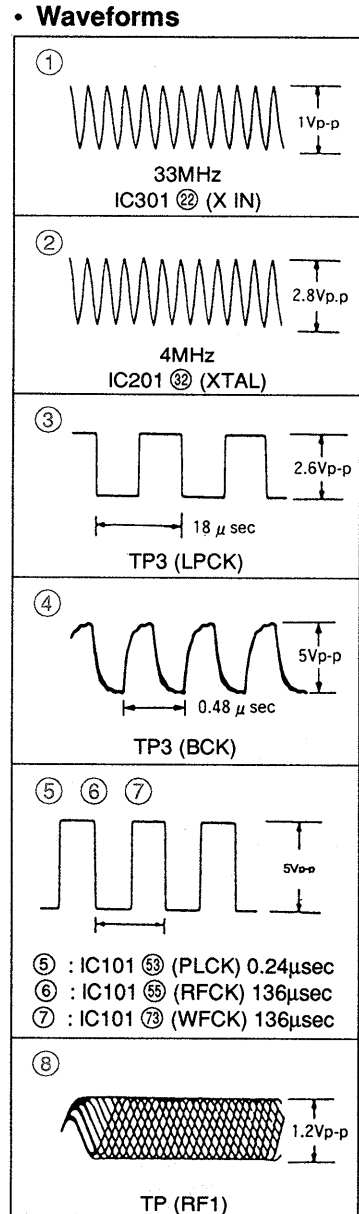
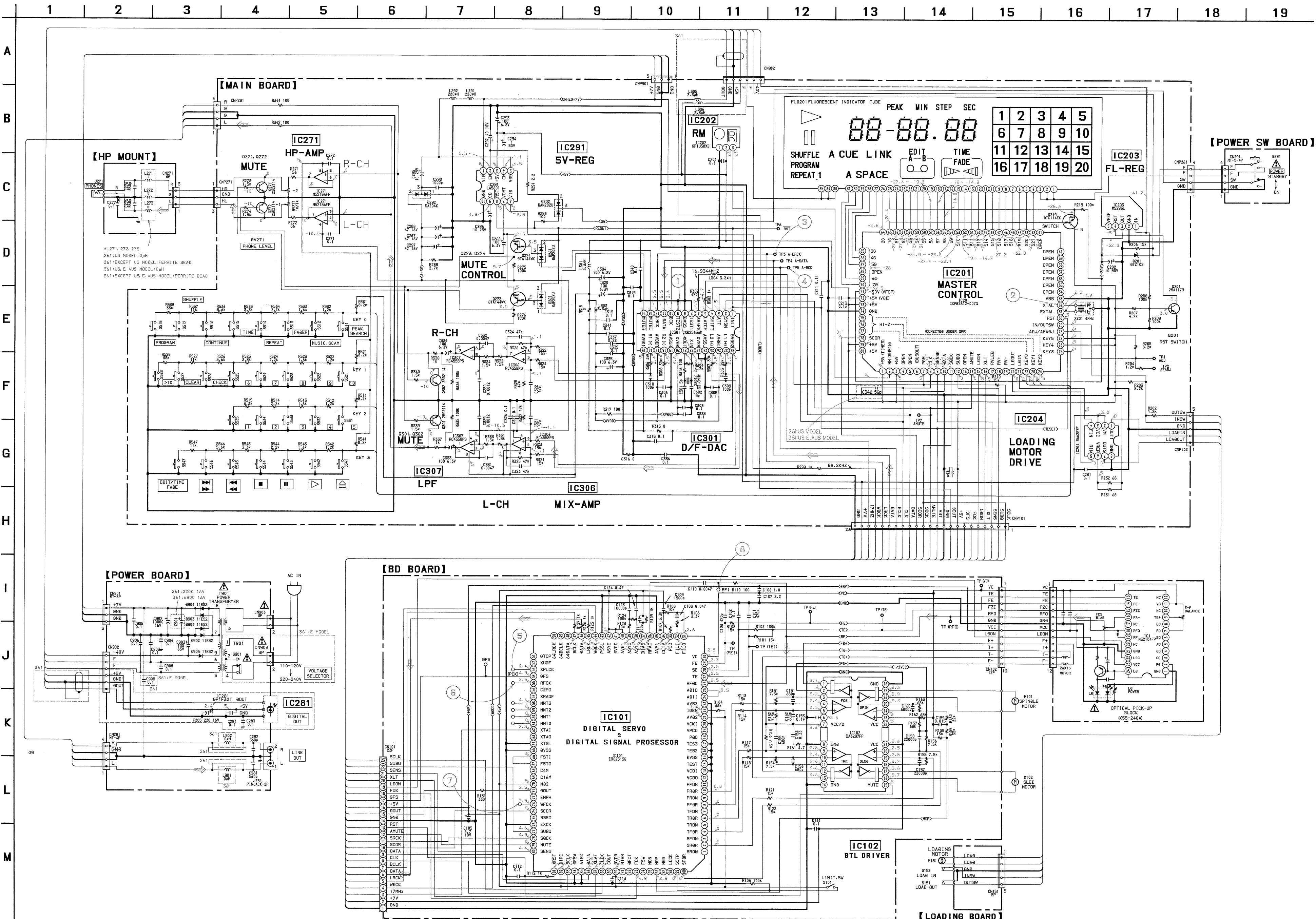

NOTE

- All capacitors are in μF unless otherwise noted. μF : μF 50WV or less are not indicated except for electrolytics and tantalums.
- All resistors are in Ω and $1/4W$ or less unless otherwise specified.
- Δ : Internal component.
- \square : Panel designation.
- Note: The components identified by mark Δ or dotted line with mark Δ are critical for safety. Replace only with part number specified.
- : B+ Line.
- - -: D- Line.
- Voltages and waveforms are dc with respect to ground under no-signal (detuned) conditions. no mark: PLAY mode.
- Voltages are taken with a VOM (input impedance 10M Ω). Voltage variations may be noted due to normal production tolerances.
- Waveforms are taken with an oscilloscope. Voltage variations may be noted due to normal production tolerances.
- Circled numbers refer to waveforms.
- Signal path.
- \Rightarrow : CB.
- Abbreviation AUS: Australia model.

IC Block Diagrams

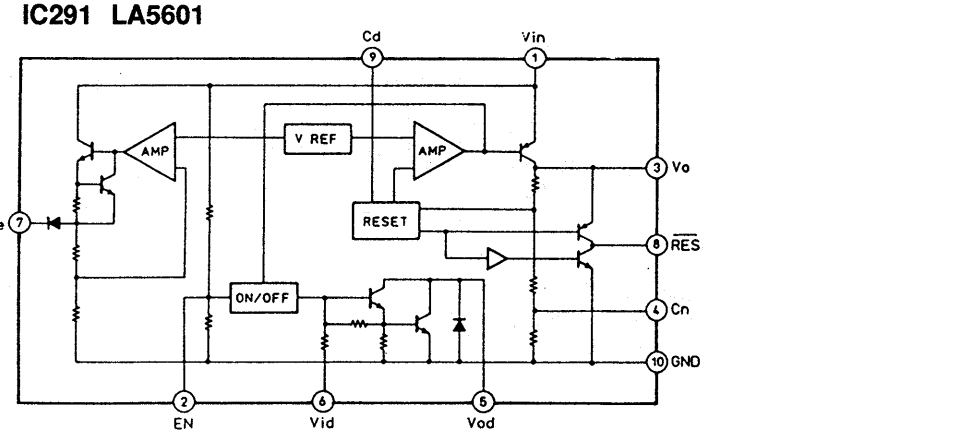
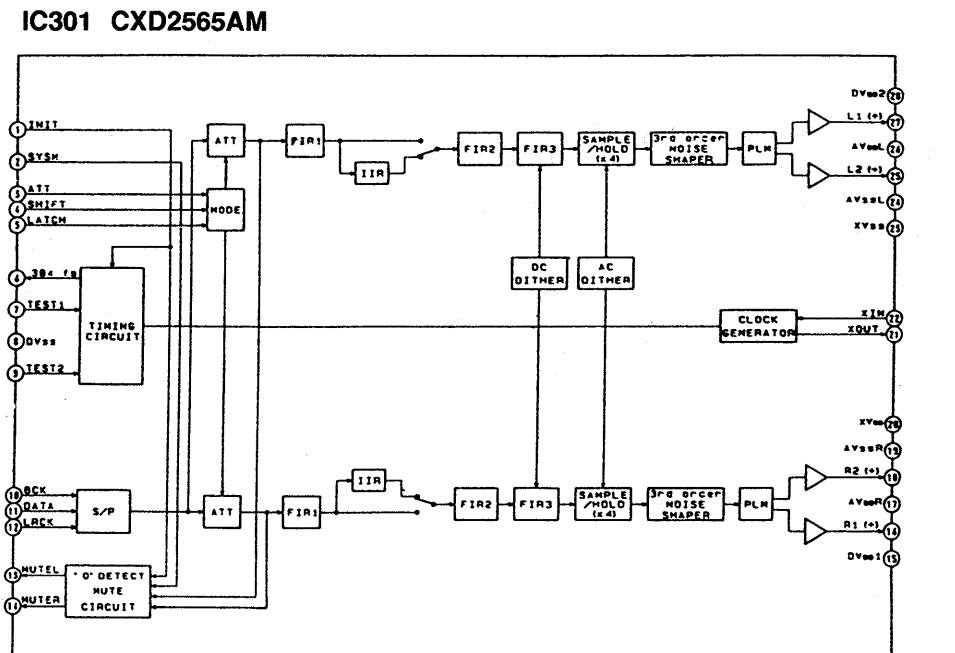
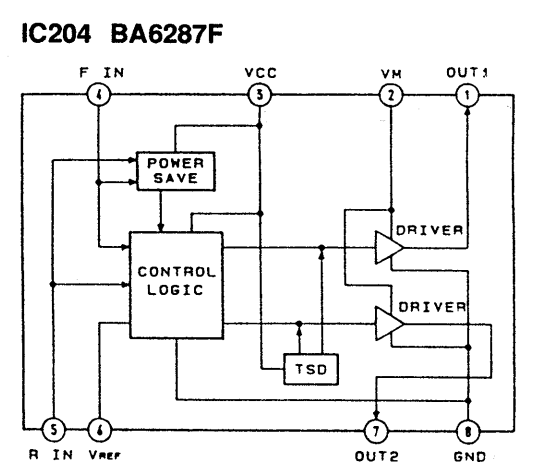
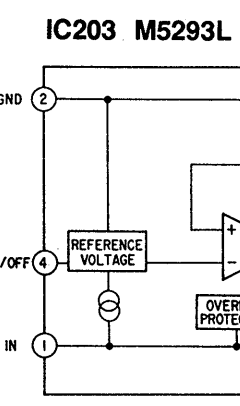
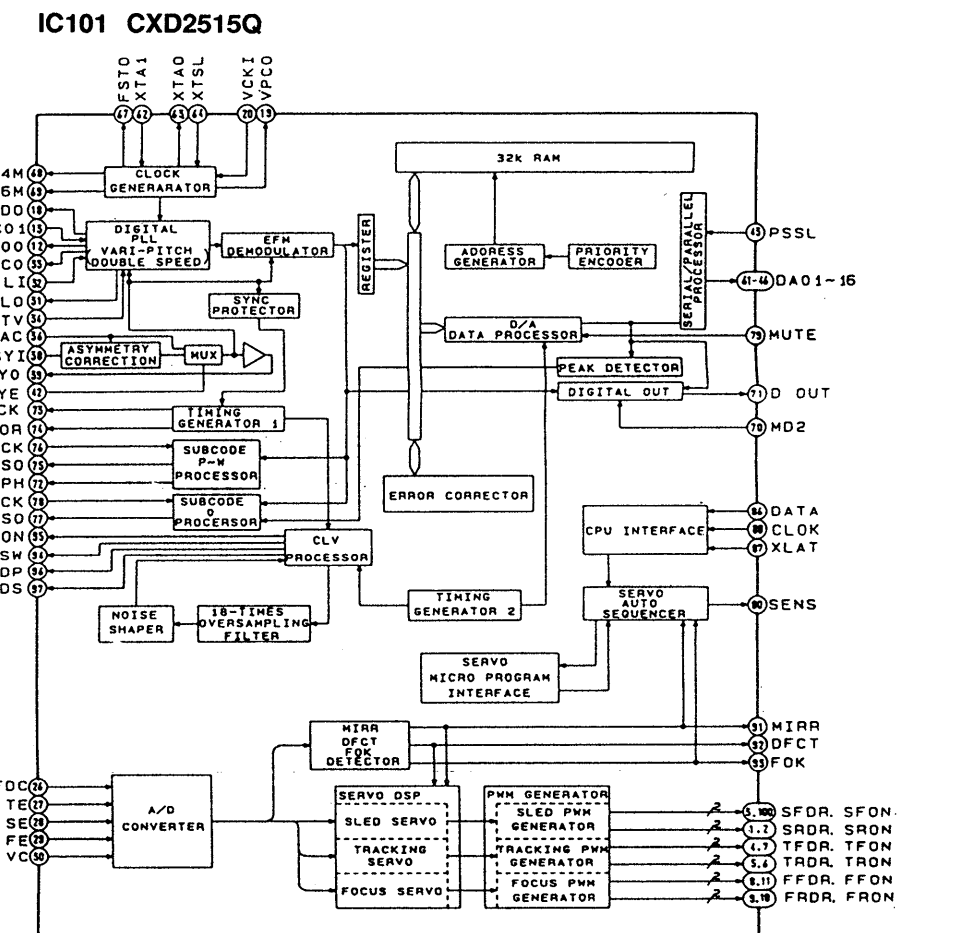

SECTION 5

EXPLODED VIEWS

NOTE:

- Items marked " * " are not stocked since they are seldom required for routine service. Some delay should be anticipated when ordering these items.
- The mechanical parts with no reference number in the exploded views are not supplied.

- Hardware (# mark) list and accessories and packing materials are given in the last of this parts list.
- Abbreviation
 G : German model
 EE : East European model
 AUS : Australian model

The components identified by mark or dotted line with mark are critical for safety. Replace only with part number specified.

5-1. CASE SECTION

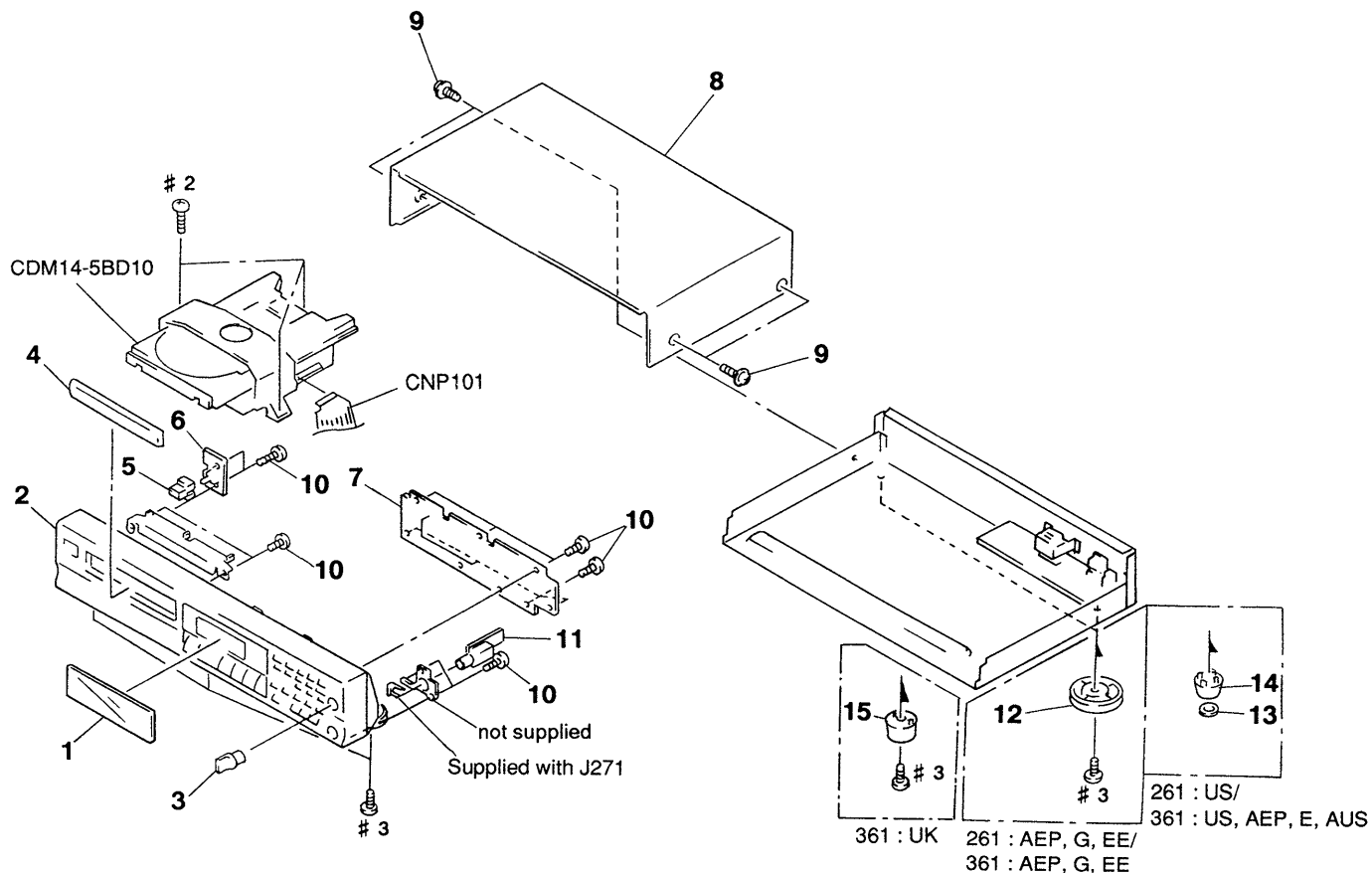

Ref. No.	Part No.	Description	Remark	Ref. No.	Part No.	Description	Remark
1	4-954-928-11	PLATE, INDICATION		* 7	A-4673-315-A	MAIN BOARD, COMPLETE (361:AEP, UK, G, EE)	
2	X-4945-299-1	PANEL ASSY, FRONT (made in FRANCE)		* 7	A-4673-389-A	MAIN BOARD, COMPLETE (261:AEP, G, EE)	
2	X-4945-300-1	PANEL ASSY, FRONT (361:US)	(361:AEP, UK, G, EE)	* 8	4-929-035-31	CASE (BAP SUMI)	
2	X-4945-301-1	PANEL ASSY, FRONT (made in CHINA)		9	3-363-099-01	SCREW (CASE 3 TP2)(made in FRANCE)	
2	X-4945-302-1	PANEL ASSY, FRONT (261:US)	(361:AEP, E, AUS)	9	3-704-366-31	SCREW (CASE)(M3X6)(made in CHINA)	(261:AEP, G, EE/361:AEP, UK, G, EE)
2	X-4945-642-1	PANEL ASSY, FRONT (261:AEP, G, EE)					(261:US/361:US, AEP, E, AUS)
3	4-925-014-01	KNOB (DIA. 10)		10	4-951-620-01	SCREW (2.6X8), +BVTP	
4	4-969-744-01	PANEL, LOADING (made in FRANCE)		* 11	1-651-267-11	HP BOARD	
4	4-969-744-11	PANEL, LOADING (261:AEP, G, EE)	(361:AEP, UK, G, EE)	* 12	4-956-885-11	FOOT (F58175S2W)(made in FRANCE)	(261:AEP, G, EE/361:AEP, G, EE)
4	4-969-750-01	PANEL, LOADING (made in CHINA)		13	4-964-668-01	CUSHION (DIA. 16)(made in CHINA)	(261:US/361:US, AEP, E, AUS)
			(361:US, AEP, E, AUS)	14	4-964-090-01	FOOT (F22175H-M)(made in CHINA)	(261:US/361:US, AEP, E, AUS)
4	4-969-750-11	PANEL, LOADING (261:US)		15	4-930-848-01	FOOT (361:UK)	
5	4-947-034-01	BUTTON (POWER)		CNP101	1-537-472-11	JUMPER, FILM (WITH TERMINAL)	(261:US/361:US, AUS, E)
* 6	1-651-266-11	POWER SW BOARD		CNP101	1-537-472-21	JUMPER, FILM (WITH TERMINAL)	(261:AEP, G, EE/361:AEP, UK, G, EE)
* 7	A-4673-313-A	MAIN BOARD, COMPLETE (361:US, E, AUS)					
* 7	A-4673-314-A	MAIN BOARD, COMPLETE (261:US)					

5-2. BACK PANEL SECTION

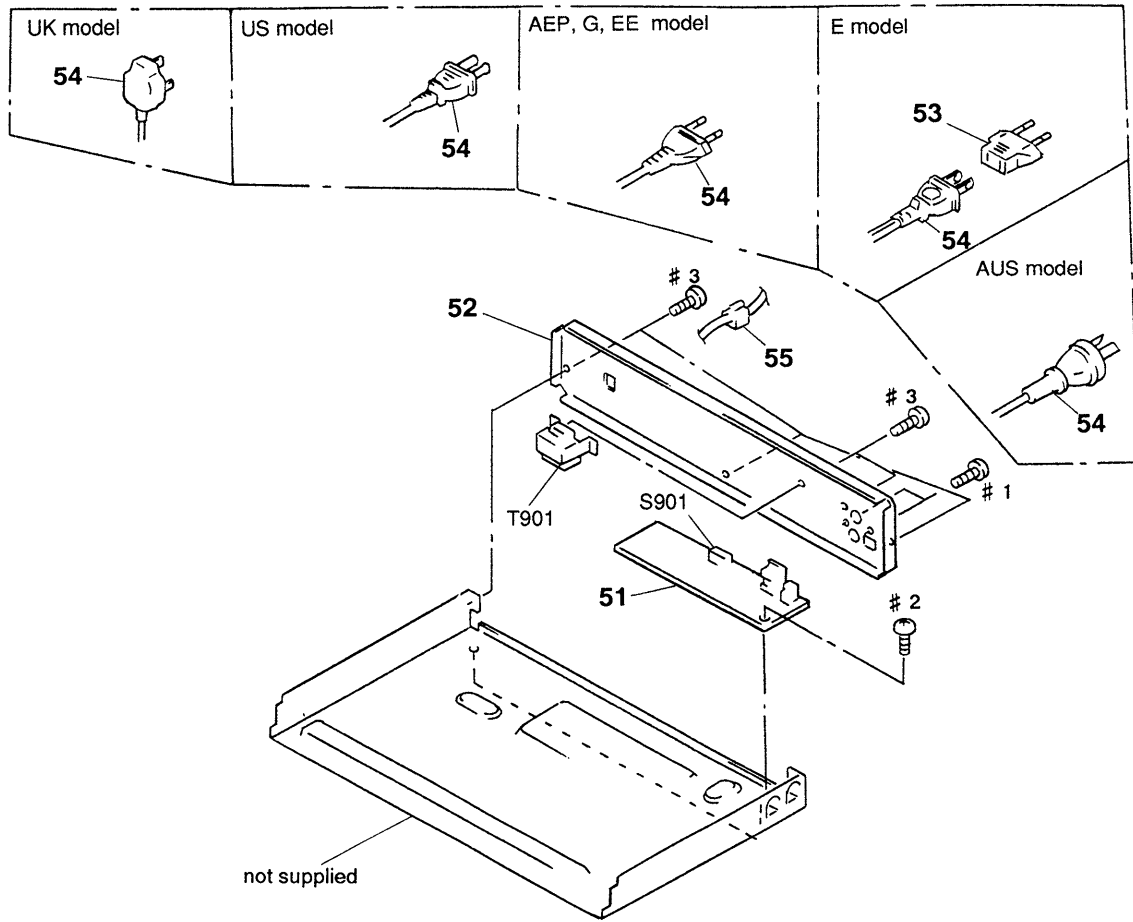

The components identified by mark \triangle or dotted line with mark \triangle are critical for safety. Replace only with part number specified.

Ref. No.	Part No.	Description	Remark	Ref. No.	Part No.	Description	Remark
* 51	1-651-265-11	POWER BOARD		\triangle 54	1-558-943-61	CORD, POWER (361:E)	
* 52	4-969-743-01	PANEL, BACK (made in FRANCE) (361:AEP, EE)		\triangle 54	1-575-651-21	CORD, POWER (AEP, G, EE)	
* 52	4-969-743-11	PANEL, BACK (261:AEP, EE)		\triangle 54	1-590-926-11	CORD, POWER (US)	
* 52	4-969-743-81	PANEL, BACK (361:G)		\triangle 54	1-696-907-11	CORD, POWER (361:UK)	
* 52	4-969-743-91	PANEL, BACK (261:G)		\triangle 54	1-696-845-11	CORD, POWER (361:AUS)	
* 52	4-969-747-01	PANEL, BACK (361:US)		* 55	3-703-244-00	BUSHING (2104), CORD (EXCEPT E)	
* 52	4-969-747-11	PANEL, BACK (made in CHINA) (361:AEP)		* 55	3-703-571-11	BUSHING (S) (4516), CORD (E)	
* 52	4-969-747-21	PANEL, BACK (361:E)		\triangle S901	1-572-675-11	SWITCH, POWER VOLTAGE CHANGE (VOLTAGE, SELECTOR) (361:E)	
* 52	4-969-747-31	PANEL, BACK (made in CHINA) (361:E)		\triangle T901	1-426-621-11	TRANSFORMER, POWER (US)	
* 52	4-969-747-41	PANEL, BACK (261:US)		\triangle T901	1-426-622-11	TRANSFORMER, POWER (E)	
* 52	4-971-521-11	PANEL, BACK (361:UK)		\triangle T901	1-423-979-11	TRANSFORMER, POWER (261:AEP, G, EE/361:AEP, UK, G, EE, AUS)	
* 52	4-973-614-01	PANEL, BACK (361:AUS)					
\triangle 53	1-569-007-11	ADAPTER, CONVERSION 2P (361:E)					

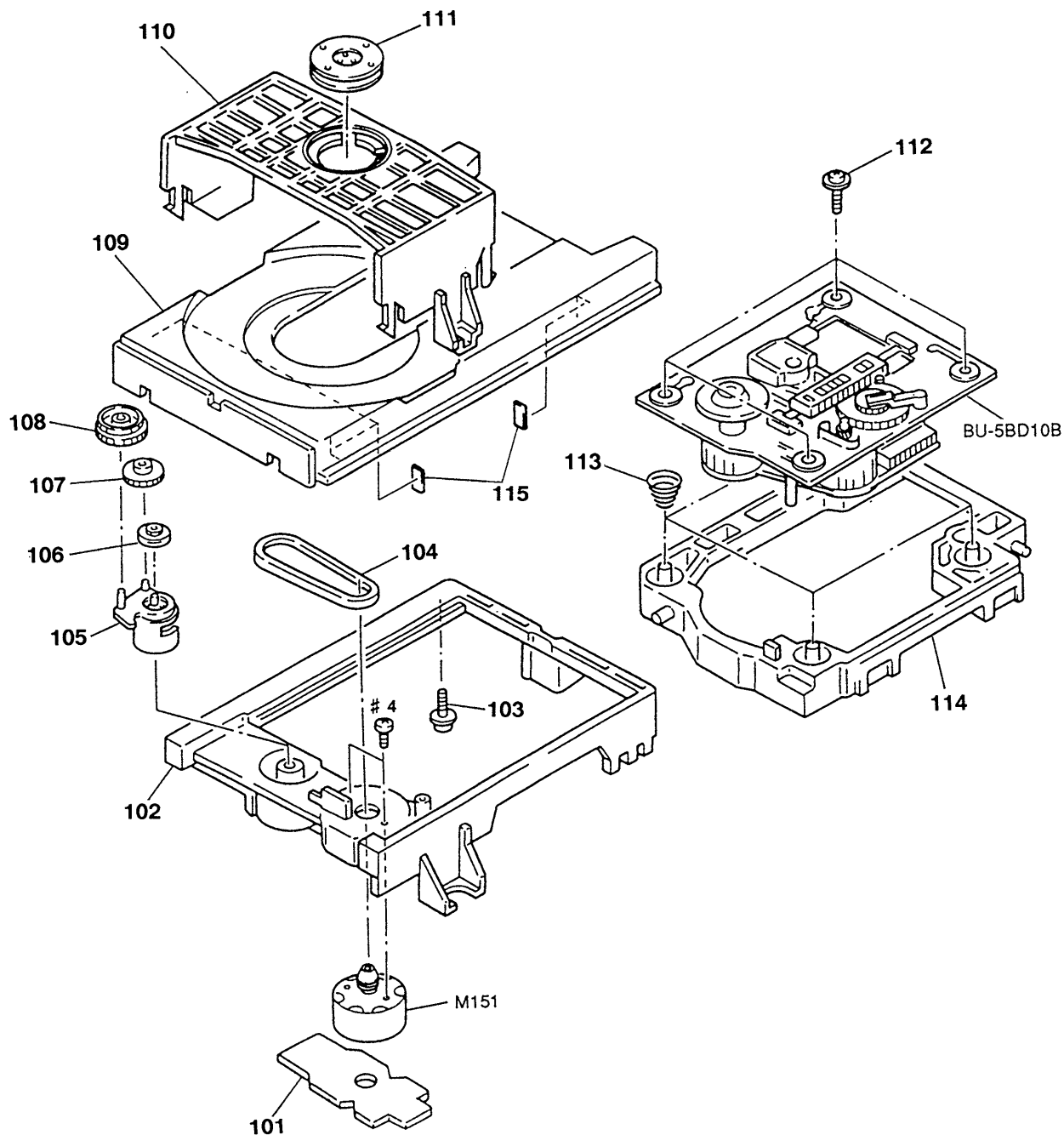

5-3. CD MECHANISM SECTION (CDM14-5BD10)

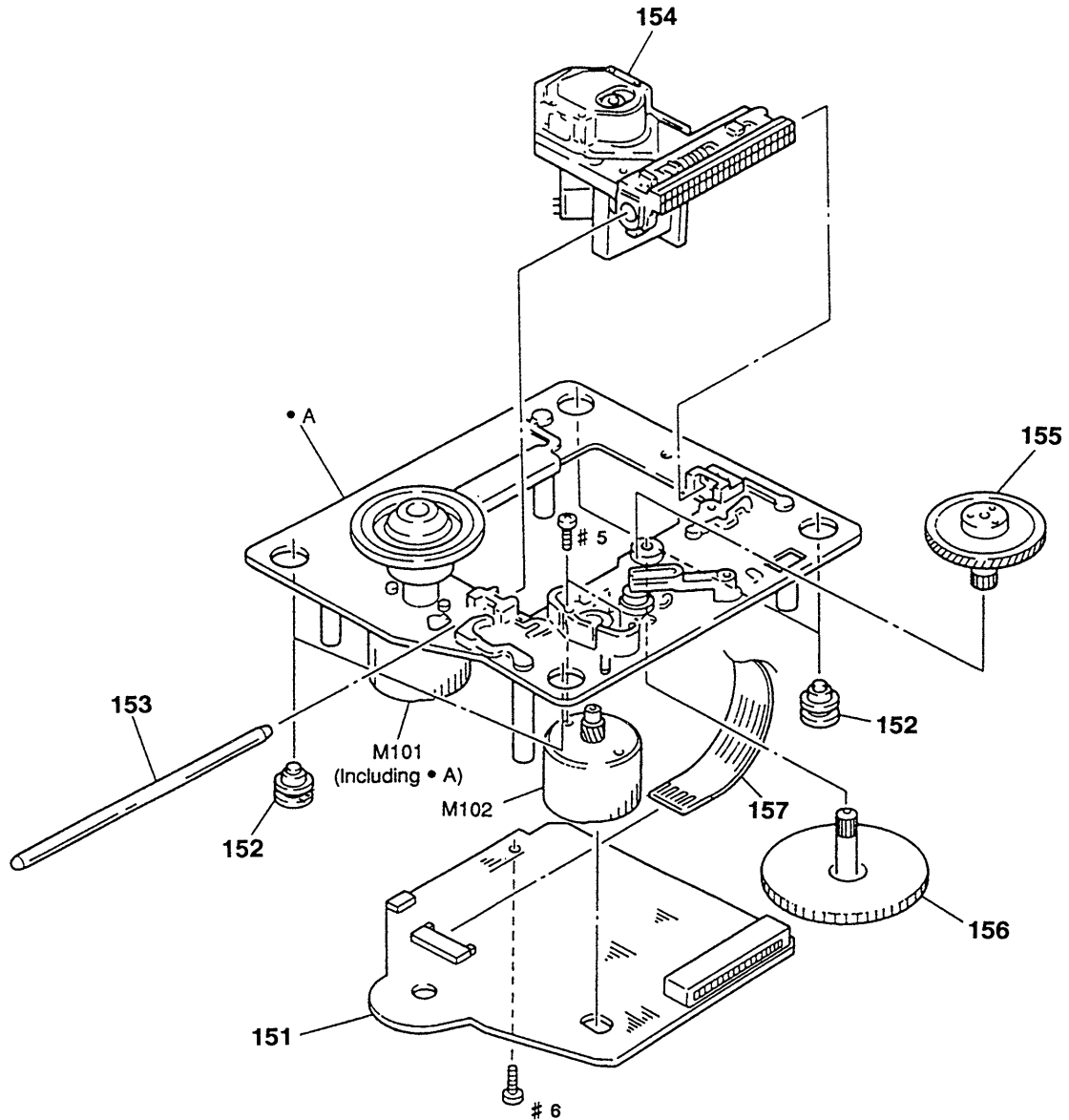

Ref.No.	Part No.	Description	Remark	Ref.No.	Part No.	Description	Remark
* 101	1-645-721-11	LOADING BOARD		110	4-933-110-01	HOLDER (MG)	
102	4-933-111-11	CHASSIS (MD)		* 111	1-452-538-11	MAGNET	
* 103	4-917-583-21	BRACKET, YOKE		112	4-933-134-01	SCREW (+PTPWH M2.6X6)	
104	4-927-649-01	BELT		113	4-959-996-01	SPRING (932), COMPRESSION	
105	4-933-109-01	CAM		114	4-933-129-01	HOLDER (BU)	
106	4-927-651-01	PULLEY (S)		115	4-925-315-31	DAMPER	
107	4-967-268-01	GEAR (C)		M151	A-4604-363-A	MOTOR (L) ASSY (LOADING)	
108	4-933-107-01	GEAR (PL)					
109	4-933-112-11	TABLE, DISC					

5-4. BASE UNIT SECTION (BU-5BD10B)



The components identified by mark  or dotted line with mark  are critical for safety. Replace only with part number specified.

Ref. No.	Part No.	Description	Remark	Ref. No.	Part No.	Description	Remark
* 151	A-4649-430-A	BD BOARD, COMPLETE (261:AEP, G, EE/361:AEP, UK, G, EE)		155	4-917-567-21	GEAR (M)	
* 151	A-4649-946-A	BD BOARD, COMPLETE (261:US/361:US, E, AUS)		156	4-917-564-01	GEAR (P), FLATNESS	
152	4-951-940-11	INSULATOR (BU)		157	1-575-001-11	WIRE, FLAT TYPE (12 CORE)	
153	4-917-565-01	SHAFT, SLED		M101	X-4917-523-3	MOTOR ASSY (SPINDLE)	
 154	8-848-144-11	OPTICAL PICK-UP BLOCK KSS-240A		M102	X-4917-504-1	MOTOR ASSY (SLED)	

SECTION 6 ELECTRICAL PARTS LIST

BD

NOTE:

The components identified by mark Δ or dotted line with mark Δ are critical for safety.
Replace only with part number specified.

When indicating parts by reference number, please include the board name.

- Due to standardization, replacements in the parts list may be different from the parts specified in the diagrams or the components used on the set.
- Items marked "*" are not stocked since they are seldom required for routine service. Some delay should be anticipated when ordering these items.
- RESISTORS
All resistors are in ohms
METAL: Metal-film resistor

- SEMICONDUCTORS
In each case, μ , for example:
uA...: μ A..., uPA...: μ PA..., uPB...: μ PB...,
uPC...: μ PC..., uPD...: μ PD...
- CAPACITORS
uF : μ F
- COILS
uH : μ H
- Abbreviation
G : German model
EE : East European model
AUS : Australian model

Ref.No.	Part No.	Description	Remark	Ref.No.	Part No.	Description	Remark
*	A-4649-430-A	BD BOARD, COMPLETE ***** (261:AEP, G, EE/361:AEP, UK, G, EE)				< MOTOR >	
				M101	X-4917-523-3	MOTOR ASSY (SPINDLE)	
				M102	X-4917-504-1	MOTOR ASSY (SLED)	
*	A-4649-946-A	BD BOARD, COMPLETE ***** (261:US/361:US, E, AUS)				< RESISTOR >	
		< CAPACITOR >		R101	1-216-077-00	METAL CHIP 15K 5%	1/10W
				R102	1-216-097-00	METAL CHIP 100K 5%	1/10W
				R103	1-216-077-00	METAL CHIP 15K 5%	1/10W
				R104	1-216-085-00	METAL CHIP 33K 5%	1/10W
				R105	1-216-097-00	METAL CHIP 100K 5%	1/10W
				R106	1-216-061-00	METAL CHIP 3.3K 5%	1/10W
				R107	1-216-061-00	METAL CHIP 3.3K 5%	1/10W
				R108	1-216-073-00	METAL CHIP 10K 5%	1/10W
				R109	1-216-121-00	METAL CHIP 1M 5%	1/10W
				R110	1-216-025-91	METAL GLAZE 100 5%	1/10W
				R112	1-216-049-91	METAL GLAZE 1K 5%	1/10W
				R113	1-216-077-00	METAL CHIP 15K 5%	1/10W
				R114	1-216-077-00	METAL CHIP 15K 5%	1/10W
				R117	1-216-077-00	METAL CHIP 15K 5%	1/10W
				R118	1-216-077-00	METAL CHIP 15K 5%	1/10W
				R121	1-216-077-00	METAL CHIP 15K 5%	1/10W
				R122	1-216-077-00	METAL CHIP 15K 5%	1/10W
				R123	1-216-073-00	METAL CHIP 10K 5%	1/10W
				R124	1-216-097-00	METAL CHIP 100K 5%	1/10W
				R125	1-216-049-91	METAL GLAZE 1K 5%	1/10W
				R126	1-216-049-91	METAL GLAZE 1K 5%	1/10W
				R127	1-216-049-91	METAL GLAZE 1K 5%	1/10W
				R131	1-216-037-00	METAL CHIP 330 5%	1/10W
				R151	1-216-070-00	METAL CHIP 7.5K 5%	1/10W
				R152	1-216-070-00	METAL CHIP 7.5K 5%	1/10W
				R153	1-216-070-00	METAL CHIP 7.5K 5%	1/10W
				R154	1-216-070-00	METAL CHIP 7.5K 5%	1/10W
				R155	1-216-070-00	METAL CHIP 7.5K 5%	1/10W
				R156	1-216-070-00	METAL CHIP 7.5K 5%	1/10W
				R157	1-216-093-00	METAL CHIP 68K 5%	1/10W
				R158	1-216-076-00	METAL CHIP 13K 5%	1/10W
				R159	1-216-085-00	METAL CHIP 33K 5%	1/10W
				R160	1-216-081-00	METAL CHIP 22K 5%	1/10W
				R161	1-216-308-00	METAL CHIP 4.7 5%	1/10W
				R162	1-216-093-00	METAL CHIP 68K 5%	1/10W
				R163	1-216-093-00	METAL CHIP 68K 5%	1/10W
		< CONNECTOR >					
*	CN101	1-568-865-11	SOCKET, CONNECTOR 23P				
	CN102	1-568-795-11	SOCKET, CONNECTOR 12P				
		< IC >					
	IC101	8-752-351-94	IC CXD2515Q				
	IC102	8-759-071-79	IC BA6297AFP				

BD HP LOADING MAIN

Ref. No.	Part No.	Description	Remark
		< SWITCH >	
S101	1-572-085-11	SWITCH, LEAF (LIMIT)	

*	1-651-267-11	HP BOARD *****	
		< CAPACITOR >	
C275	1-162-291-31	CERAMIC 560PF 10% 50V	
C276	1-162-291-31	CERAMIC 560PF 10% 50V	
C277	1-164-159-11	CERAMIC 0.1uF 50V	
		< CONNECTOR >	
* CN271	1-568-941-11	PIN, CONNECTOR 3P	
		< JACK >	
J271	1-568-519-41	JACK, LARGE TYPE (PHONES) (261:US/361:US, E, AUS)	
J271	1-770-306-11	JACK (LARGE TYPE) (PHONES) (261:AEP, G, EE/361:AEP, UK, G, EE)	
		< COIL >	
L271	1-410-397-21	FERRITE BEAD INDUCTOR (261:AEP, G, EE/361:AEP, UK, G, EE)	
L271	1-412-473-21	INDUCTOR 0uH (261:US/361:US, E, AUS)	
L272	1-410-397-21	FERRITE BEAD INDUCTOR (261:AEP, G, EE/361:AEP, UK, G, EE)	
L272	1-412-473-21	INDUCTOR 0uH (261:US/361:US, E, AUS)	
L273	1-410-397-21	FERRITE BEAD INDUCTOR (261:AEP, G, EE/361:AEP, UK, G, EE)	
L273	1-412-473-21	INDUCTOR 0uH (261:US/361:US, E, AUS)	

	1-645-721-11	LOADING BOARD *****	
		< CONNECTOR >	
* CN151	1-568-943-11	PIN, CONNECTOR 5P	
		< MOTOR >	
M151	A-4604-363-A	MOTOR (L) ASSY (LOADING)	
		< SWITCH >	
S151	1-572-086-11	SWITCH, LEAF (LOAD OUT)	
S152	1-572-086-11	SWITCH, LEAF (LOAD IN)	

Ref. No.	Part No.	Description	Remark
*	A-4673-313-A	MAIN BOARD, COMPLETE (361:US, E, AUS) *****	
*	A-4673-314-A	MAIN BOARD, COMPLETE (261:US) *****	
*	A-4673-315-A	MAIN BOARD, COMPLETE (361:AEP, UK, G, EE) *****	
*	A-4673-389-A	MAIN BOARD, COMPLETE (261:AEP, G, EE) *****	
		< CAPACITOR >	
C201	1-163-038-91	CERAMIC CHIP 0.1uF 25V	
C202	1-124-261-00	ELECT 10uF 20% 50V (261:US/361:US, E, AUS)	
C202	1-126-964-11	ELECT 10uF 20% 50V (261:AEP, G, EE/361:AEP, UK, G, EE)	
C210	1-163-038-91	CERAMIC CHIP 0.1uF 25V	
C211	1-163-038-91	CERAMIC CHIP 0.1uF 25V	
C213	1-163-038-91	CERAMIC CHIP 0.1uF 25V	
C231	1-163-038-91	CERAMIC CHIP 0.1uF 25V	
C266	1-124-584-00	ELECT 100uF 20% 10V (261:US/361:US, E, AUS)	
C266	1-126-177-11	ELECT 100uF 20% 10V (261:AEP, G, EE/361:AEP, UK, G, EE)	
C271	1-163-038-91	CERAMIC CHIP 0.1uF 25V	
C272	1-163-038-91	CERAMIC CHIP 0.1uF 25V	
C287	1-124-589-11	ELECT 47uF 20% 16V	
C288	1-124-589-11	ELECT 47uF 20% 16V	
C292	1-126-157-11	ELECT 10uF 20% 16V	
C293	1-124-584-00	ELECT 100uF 20% 10V (261:US/361:US, E, AUS)	
C293	1-126-177-11	ELECT 100uF 20% 10V (261:AEP, G, EE/361:AEP, UK, G, EE)	
C294	1-126-160-11	ELECT 1uF 20% 50V	
C295	1-126-096-11	ELECT 10uF 20% 35V	
C296	1-126-096-11	ELECT 10uF 20% 35V	
C297	1-124-589-11	ELECT 47uF 20% 16V	
C298	1-163-275-11	CERAMIC CHIP 0.001uF 5% 50V	
C301	1-163-088-00	CERAMIC CHIP 5PF 50V	
C302	1-163-088-00	CERAMIC CHIP 5PF 50V	
C303	1-163-038-91	CERAMIC CHIP 0.1uF 25V	
C304	1-124-584-00	ELECT 100uF 20% 10V (261:US/361:US, E, AUS)	
C304	1-126-177-11	ELECT 100uF 20% 10V (261:AEP, G, EE/361:AEP, UK, G, EE)	
C305	1-163-038-91	CERAMIC CHIP 0.1uF 25V	
C306	1-163-038-91	CERAMIC CHIP 0.1uF 25V	
C309	1-163-251-11	CERAMIC CHIP 100PF 5% 50V	
C310	1-163-251-11	CERAMIC CHIP 100PF 5% 50V	
C315	1-163-038-91	CERAMIC CHIP 0.1uF 25V	
C316	1-216-295-00	METAL CHIP 0 5% 1/10W	

Ref. No.	Part No.	Description	Remark	Ref. No.	Part No.	Description	Remark
C318	1-163-038-91	CERAMIC CHIP	0. 1uF 25V			< IC >	
C319	1-163-038-91	CERAMIC CHIP	0. 1uF 25V				
C320	1-124-584-00	ELECT	100uF 20% 10V (261:US/361:US, E, AUS)	IC201	8-752-858-69	IC CXP82612-007Q	
C320	1-126-177-11	ELECT	100uF 20% 10V (261:AEP, G, EE/361:AEP, UK, G, EE)	IC202	8-749-923-11	IC GPlU58XB (R)	
C321	1-163-243-11	CERAMIC CHIP	47PF 5% 50V	IC203	8-759-633-42	IC M5293L	
C322	1-163-243-11	CERAMIC CHIP	47PF 5% 50V	IC204	8-759-040-83	IC BA6287F	
C323	1-163-243-11	CERAMIC CHIP	47PF 5% 50V	IC271	8-759-636-55	IC M5218AFP	
C324	1-163-243-11	CERAMIC CHIP	47PF 5% 50V	IC291	8-759-821-93	IC LA5601	
C326	1-163-038-91	CERAMIC CHIP	0. 1uF 25V	IC301	8-752-367-61	IC CXD2565AM	
C327	1-163-038-91	CERAMIC CHIP	0. 1uF 25V	IC306	8-759-996-43	IC RC4558FS	
C329	1-163-143-00	CERAMIC CHIP	0. 0012uF 5% 50V	IC307	8-759-996-43	IC RC4558FS	
C330	1-163-143-00	CERAMIC CHIP	0. 0012uF 5% 50V			< COIL >	
C331	1-163-017-00	CERAMIC CHIP	0. 0047uF 5% 50V	L291	1-410-658-31	INDUCTOR CHIP 220uH	
C332	1-163-017-00	CERAMIC CHIP	0. 0047uF 5% 50V	L292	1-410-658-31	INDUCTOR CHIP 220uH	
C333	1-124-584-00	ELECT	100uF 20% 10V (261:US/361:US, E, AUS)	L301	1-410-375-11	INDUCTOR CHIP 3. 3uH	
C333	1-126-177-11	ELECT	100uF 20% 10V (261:AEP, G, EE/361:AEP, UK, G, EE)	L303	1-410-375-11	INDUCTOR CHIP 3. 3uH	
C334	1-124-584-00	ELECT	100uF 20% 10V (261:US/361:US, E, AUS)	L304	1-410-375-11	INDUCTOR CHIP 3. 3uH	
C334	1-126-177-11	ELECT	100uF 20% 10V (261:AEP, G, EE/361:AEP, UK, G, EE)	L305	1-410-375-11	INDUCTOR CHIP 3. 3uH (361)	
C335	1-124-584-00	ELECT	100uF 20% 10V (261:US/361:US, E, AUS)	L306	1-410-375-11	INDUCTOR CHIP 3. 3uH (361)	
C335	1-126-177-11	ELECT	100uF 20% 10V (261:AEP, G, EE/361:AEP, UK, G, EE)			< TRANSISTOR >	
C336	1-163-038-91	CERAMIC CHIP	0. 1uF 25V	Q201	8-729-820-76	TRANSISTOR 2SA1179-M5M6	
C337	1-163-081-00	CERAMIC CHIP	0. 22uF 25V	Q219	8-729-027-43	TRANSISTOR DTC114EKA	
C338	1-163-038-91	CERAMIC CHIP	0. 1uF 25V	Q271	8-729-023-22	TRANSISTOR 2SD2114K	
C339	1-163-038-91	CERAMIC CHIP	0. 1uF 25V	Q272	8-729-023-22	TRANSISTOR 2SD2114K	
C340	1-163-038-91	CERAMIC CHIP	0. 1uF 25V	Q273	8-729-027-41	TRANSISTOR DTA144WKA	
C341	1-163-038-91	CERAMIC CHIP	0. 1uF 25V	Q274	8-729-027-41	TRANSISTOR DTA144WKA	
C342	1-101-884-00	CERAMIC	56PF 5% 50V (261:US/361:US, E, AUS)	Q301	8-729-023-22	TRANSISTOR 2SD2114K	
		< CONNECTOR >		Q302	8-729-023-22	TRANSISTOR 2SD2114K	
CNP101	1-537-472-11	JUMPER, FILM (WITH TERMINAL)	(261:US/361:US, E, AUS)			< RESISTOR >	
CNP101	1-537-472-21	JUMPER, FILM (WITH TERMINAL)	(261:AEP, G, EE/361:AEP, UK, G, EE)	R202	1-216-051-00	METAL CHIP 1. 2K 5% 1/10W	
		< DIODE >		R203	1-216-071-00	METAL CHIP 8. 2K 5% 1/10W	
D201	8-719-977-28	DIODE DTZ10B		R204	1-216-051-00	METAL CHIP 1. 2K 5% 1/10W	
D202	8-719-941-86	DIODE DAN202U		R205	1-216-071-00	METAL CHIP 8. 2K 5% 1/10W	
D261	8-719-941-09	DIODE DAP202U		R206	1-216-077-00	METAL CHIP 15K 5% 1/10W	
D262	8-719-941-09	DIODE DAP202U		R207	1-216-065-00	METAL CHIP 4. 7K 5% 1/10W	
D292	8-719-914-42	DIODE DA204K		R208	1-216-097-00	METAL CHIP 100K 5% 1/10W	
		< FLUORESCENT INDICATOR >		R209	1-216-097-00	METAL CHIP 100K 5% 1/10W	
FLD201	1-519-752-11	INDICATOR TUBE, FLUORESCENT		R210	1-216-077-00	METAL CHIP 15K 5% 1/10W	
				R219	1-216-097-00	METAL CHIP 100K 5% 1/10W	
				R231	1-216-021-00	METAL CHIP 68 5% 1/10W	
				R232	1-216-021-00	METAL CHIP 68 5% 1/10W	
				R271	1-216-019-00	METAL CHIP 56 5% 1/10W	
				R272	1-216-019-00	METAL CHIP 56 5% 1/10W	
				R273	1-216-053-00	METAL CHIP 1. 5K 5% 1/10W	
				R274	1-216-053-00	METAL CHIP 1. 5K 5% 1/10W	
				R275	1-216-097-00	METAL CHIP 100K 5% 1/10W	
				R276	1-216-097-00	METAL CHIP 100K 5% 1/10W	
				R288	1-216-059-00	METAL CHIP 2. 7K 5% 1/10W	

MAIN

Ref. No.	Part No.	Description	Remark	Ref. No.	Part No.	Description	Remark
R291	1-216-298-00	METAL CHIP	2.2 5% 1/10W	R534	1-216-057-00	METAL CHIP	2.2K 5% 1/10W
R293	1-216-025-91	METAL CHIP	100 5% 1/10W	R535	1-216-061-00	METAL CHIP	3.3K 5% 1/10W
R299	1-216-049-91	METAL CHIP	1K 5% 1/10W	R536	1-216-067-00	METAL CHIP	5.6K 5% 1/10W
R302	1-216-041-00	METAL CHIP	470 5% 1/10W	R537	1-216-074-00	METAL CHIP	11K 5% 1/10W
R303	1-216-049-91	METAL CHIP	1K 5% 1/10W	R538	1-216-085-00	METAL CHIP	33K 5% 1/10W
R304	1-216-065-00	METAL CHIP	4.7K 5% 1/10W	R541	1-216-071-00	METAL CHIP	8.2K 5% 1/10W
R305	1-216-689-11	METAL CHIP	39K 0.5% 1/10W	R542	1-216-051-00	METAL CHIP	1.2K 5% 1/10W
R306	1-216-689-11	METAL CHIP	39K 0.5% 1/10W	R543	1-216-054-00	METAL CHIP	1.6K 5% 1/10W
R307	1-216-689-11	METAL CHIP	39K 0.5% 1/10W	R544	1-216-057-00	METAL CHIP	2.2K 5% 1/10W
R308	1-216-689-11	METAL CHIP	39K 0.5% 1/10W	R545	1-216-061-00	METAL CHIP	3.3K 5% 1/10W
R315	1-216-296-00	METAL CHIP	0 5% 1/8W	R546	1-216-067-00	METAL CHIP	5.6K 5% 1/10W
R316	1-216-025-91	METAL CHIP	100 5% 1/10W	R547	1-216-074-00	METAL CHIP	11K 5% 1/10W
R317	1-216-025-91	METAL CHIP	100 5% 1/10W			< VARIABLE RESISTOR >	
R318	1-216-295-00	METAL CHIP	0 5% 1/10W	RV271	1-223-570-11	RES, VAR, CARBON 1K/1K (PHONE LEVEL)	
R321	1-216-077-00	METAL CHIP	15K 5% 1/10W			< SWITCH >	
R322	1-216-077-00	METAL CHIP	15K 5% 1/10W	S511	1-554-303-21	SWITCH, TACTILE (PEAK SEARCH)	
R323	1-216-077-00	METAL CHIP	15K 5% 1/10W	S512	1-554-303-21	SWITCH, TACTILE (MUSIC SCAN)	
R324	1-216-077-00	METAL CHIP	15K 5% 1/10W	S513	1-554-303-21	SWITCH, TACTILE (FADER)	
R325	1-216-089-00	METAL CHIP	47K 5% 1/10W	S514	1-554-303-21	SWITCH, TACTILE (REPEAT)	
R326	1-216-089-00	METAL CHIP	47K 5% 1/10W	S515	1-554-303-21	SWITCH, TACTILE (TIME)	
R327	1-216-089-00	METAL CHIP	47K 5% 1/10W	S516	1-554-303-21	SWITCH, TACTILE (CONTINUE)	
R328	1-216-089-00	METAL CHIP	47K 5% 1/10W	S517	1-554-303-21	SWITCH, TACTILE (SHUFFLE)	
R331	1-216-053-00	METAL CHIP	1.5K 5% 1/10W	S518	1-554-303-21	SWITCH, TACTILE (PROGRAM)	
R332	1-216-053-00	METAL CHIP	1.5K 5% 1/10W	S521	1-554-303-21	SWITCH, TACTILE (10)	
R333	1-216-053-00	METAL CHIP	1.5K 5% 1/10W	S522	1-554-303-21	SWITCH, TACTILE (9)	
R334	1-216-053-00	METAL CHIP	1.5K 5% 1/10W	S523	1-554-303-21	SWITCH, TACTILE (8)	
R335	1-216-097-00	METAL CHIP	100K 5% 1/10W	S524	1-554-303-21	SWITCH, TACTILE (7)	
R336	1-216-097-00	METAL CHIP	100K 5% 1/10W	S525	1-554-303-21	SWITCH, TACTILE (6)	
R337	1-216-049-91	METAL CHIP	1K 5% 1/10W	S526	1-554-303-21	SWITCH, TACTILE (CHECK)	
R338	1-216-049-91	METAL CHIP	1K 5% 1/10W	S527	1-554-303-21	SWITCH, TACTILE (CLEAR)	
R339	1-216-053-00	METAL CHIP	1.5K 5% 1/10W	S528	1-554-303-21	SWITCH, TACTILE (>10)	
R340	1-216-053-00	METAL CHIP	1.5K 5% 1/10W	S531	1-554-303-21	SWITCH, TACTILE (5)	
R341	1-216-025-91	METAL CHIP	100 5% 1/10W	S532	1-554-303-21	SWITCH, TACTILE (4)	
R342	1-216-025-91	METAL CHIP	100 5% 1/10W	S533	1-554-303-21	SWITCH, TACTILE (3)	
R511	1-216-071-00	METAL CHIP	8.2K 5% 1/10W	S534	1-554-303-21	SWITCH, TACTILE (2)	
R512	1-216-051-00	METAL CHIP	1.2K 5% 1/10W	S535	1-554-303-21	SWITCH, TACTILE (1)	
R513	1-216-054-00	METAL CHIP	1.6K 5% 1/10W	S541	1-554-303-21	SWITCH, TACTILE (△)	
R514	1-216-057-00	METAL CHIP	2.2K 5% 1/10W	S542	1-554-303-21	SWITCH, TACTILE (▷)	
R515	1-216-061-00	METAL CHIP	3.3K 5% 1/10W	S543	1-554-303-21	SWITCH, TACTILE (■)	
R521	1-216-071-00	METAL CHIP	8.2K 5% 1/10W	S544	1-554-303-21	SWITCH, TACTILE (■)	
R522	1-216-051-00	METAL CHIP	1.2K 5% 1/10W	S545	1-554-303-21	SWITCH, TACTILE (◀◀ ▶▶)	
R523	1-216-054-00	METAL CHIP	1.6K 5% 1/10W	S546	1-554-303-21	SWITCH, TACTILE (▶▶ ▷▷)	
R524	1-216-057-00	METAL CHIP	2.2K 5% 1/10W	S547	1-554-303-21	SWITCH, TACTILE (EDIT/TIME FADE)	
R525	1-216-061-00	METAL CHIP	3.3K 5% 1/10W			< VIBRATOR >	
R526	1-216-067-00	METAL CHIP	5.6K 5% 1/10W	X201	1-577-082-11	VIBRATOR, CERAMIC (4MHz)	
R527	1-216-074-00	METAL CHIP	11K 5% 1/10W	X301	1-579-833-21	VIBRATOR, CRYSTAL (33.8MHz) (261)	
R528	1-216-085-00	METAL CHIP	33K 5% 1/10W				
R531	1-216-071-00	METAL CHIP	8.2K 5% 1/10W				
R532	1-216-051-00	METAL CHIP	1.2K 5% 1/10W				
R533	1-216-054-00	METAL CHIP	1.6K 5% 1/10W				

MAIN

POWER

POWER SW

Ref. No.	Part No.	Description	Remark	Ref. No.	Part No.	Description	Remark
X301	1-579-834-11	VIBRATOR, CRYSTAL (33.8MHz) (361)		L902	1-412-473-41	INDUCTOR 0uH (361)	
*****				< SWITCH >			
*	1-651-265-11	POWER BOARD *****		△S901	1-572-675-11	SWITCH, POWER VOLTAGE CHANGE (VOLTAGE, SELECTOR) (361:E)	
< CAPACITOR >				< TRANSFORMER >			
C281	1-162-291-31	CERAMIC 560PF 10% 50V		△T901	1-423-979-11	TRANSFORMER, POWER (261:AEP, G, EE/361:AEP, UK, G, EE, AUS)	
C282	1-162-291-31	CERAMIC 560PF 10% 50V		△T901	1-426-621-11	TRANSFORMER, POWER (US)	
C283	1-164-159-11	CERAMIC 0.1uF 50V (361)		△T901	1-426-622-11	TRANSFORMER, POWER (361:E)	
C284	1-136-165-00	FILM 0.1uF 5% 50V (361)		*****			
C285	1-126-934-11	ELECT 220uF 20% 16V (361)		*	1-651-266-11	POWER SW BOARD *****	
C901	1-124-556-11	ELECT 2200uF 20% 16V (261:AEP, G, EE)		< CONNECTOR >			
C901	1-124-894-11	ELECT 6800uF 20% 16V (361)		CN291	1-506-469-11	PIN, CONNECTOR 4P	
C901	1-126-768-11	ELECT 2200uF 20% 16V (261:US)		< SWITCH >			
C902	1-126-939-11	ELECT 10000uF 20% 16V		△S291	1-554-118-00	SWITCH, PUSH (1 KEY) (POWER)	
C903	1-124-572-11	ELECT 100uF 20% 63V (261:US/361:US, E, AUS)		*****			
C903	1-128-576-11	ELECT 100uF 20% 63V (361:AEP, UK, G, EE)		MISCELLANEOUS *****			
C904	1-164-159-11	CERAMIC 0.1uF 50V		△53	1-569-007-11	ADAPTER, CONVERSION 2P (361:E)	
C905	1-164-159-11	CERAMIC 0.1uF 50V		△54	1-558-943-61	CORD, POWER (361:E)	
C906	1-164-159-11	CERAMIC 0.1uF 50V		△54	1-575-651-21	CORD, POWER (AEP, G, EE)	
C907	1-164-159-11	CERAMIC 0.1uF 50V		△54	1-590-926-11	CORD, POWER (US)	
C908	1-164-159-11	CERAMIC 0.1uF 50V		△54	1-696-907-11	CORD, POWER (361:UK)	
C909	1-164-159-11	CERAMIC 0.1uF 50V (361:E)		△54	1-696-845-11	CORD, POWER (361:AUS)	
< CONNECTOR >				* 111	1-452-538-11	MAGNET	
CN281	1-506-469-11	PIN, CONNECTOR 4P		△154	8-848-144-11	OPTICAL PICK-UP BLOCK KSS-240A	
CN901	1-506-468-11	PIN, CONNECTOR 3P		157	1-575-001-11	WIRE, FLAT TYPE (12 CORE)	
CN902	1-506-468-11	PIN, CONNECTOR 3P (261)		CNP101	1-537-472-11	JUMPER, FILM (WITH TERMINAL) (261:US/361:US, E, AUS)	
* CN902	1-564-708-11	PIN, CONNECTOR (SMALL TYPE) 6P (361)		CNP101	1-537-472-21	JUMPER, FILM (WITH TERMINAL) (261:AEP, G, EE/361:AEP, UK, G, EE)	
CN903	1-580-230-11	PIN, CONNECTOR (PC BOARD) 3P		M101	X-4917-523-3	MOTOR ASSY (SPINDLE)	
< DIODE >				M102	X-4917-504-1	MOTOR ASSY (SLED)	
D901	8-719-200-82	DIODE 11ES2		M151	A-4604-363-A	MOTOR (L) ASSY (LOADING)	
D902	8-719-200-82	DIODE 11ES2		△S901	1-572-675-11	SWITCH, POWER VOLTAGE CHANGE (VOLTAGE SELECTOR) (361:E)	
D903	8-719-200-82	DIODE 11ES2		*****			
D904	8-719-200-82	DIODE 11ES2		△T901	1-426-621-11	TRANSFORMER, POWER (US)	
D905	8-719-200-82	DIODE 11ES2		△T901	1-426-622-11	TRANSFORMER, POWER (361:E)	
< IC >				△T901	1-423-979-11	TRANSFORMER, POWER (261:AEP, G, EE/361:AEP, UK, G, EE, AUS)	
IC281	8-749-921-12	IC GP1F32T (DIGITAL OUT) (361)		*****			
< JACK >				The components identified by mark △ or dotted line with mark △ are critical for safety. Replace only with part number specified.			
J281	1-750-679-21	JACK, PIN 2P (LINE OUT)					
< COIL >							
L901	1-412-473-41	INDUCTOR 0uH (361)					

Ref. No.	Part No.	Description	Remark
		ACCESSORIES & PACKING MATERIALS *****	
	1-467-880-11	REMOTE COMMANDER (RM-D420) (361)	
	1-558-271-11	CORD, CONNECTION	
	3-759-483-11	MANUAL, INSTRUCTION (ENGLISH, FRENCH, SPANISH, CHINESE) (361:AEP, E, AUS)	
	3-759-483-21	MANUAL, INSTRUCTION (ENGLISH) (US)	
	3-759-483-51	MANUAL, INSTRUCTION (ENGLISH, FRENCH, SPANISH) (261:AEP/361:AEP, UK)	
	3-759-483-61	MANUAL, INSTRUCTION (GERMAN, DUTCH, ITALIAN, PORTUGUESE) (AEP)	
	3-759-483-71	MANUAL, INSTRUCTION (GERMAN) (G)	
	3-759-483-81	MANUAL, INSTRUCTION (ENGLISH, RUSSIAN, POLISH) (EE)	
	3-759-483-91	MANUAL, INSTRUCTION (SWEDISH, FINNISH) (361:AEP)	
*	4-925-389-11	CUSHION (261:US/361:US, AEP, E, AUS)	
*	4-929-506-01	CUSHION (261:AEP, G, EE/361:AEP, UK, G, EE)	
	4-962-615-01	COVER, BATTERY (for RM-D420)	
*	4-969-745-01	INDIVIDUAL CARTON (made in FRANCE) (361:AEP, UK, G, EE)	
*	4-969-745-31	INDIVIDUAL CARTON (261:AEP, G, EE)	
*	4-969-748-01	INDIVIDUAL CARTON (361:US, E, AUS)	
*	4-969-748-11	INDIVIDUAL CARTON (made in CHINA) (361:AEP)	
*	4-969-748-31	INDIVIDUAL CARTON (made in CHINA) (361:E)	
*	4-969-748-41	INDIVIDUAL CARTON (261:US)	

		***** HARDWARE LIST *****	
#1	7-685-646-79	SCREW +BVTP 3X8 TYPE2 N-S	
#2	7-685-871-01	SCREW +BVTT 3X6 (S)	
#3	7-682-548-04	SCREW +BVTT 3X8 (S)	
#4	7-621-775-10	SCREW +B 2. 6X4	
#5	7-621-255-15	SCREW +P 2X3	
#6	7-685-134-19	SCREW +BTP 2. 6X8 TYPE2 N-S	

CDP-261/361

SONY® SERVICE MANUAL

*US Model
AEP Model
CDP-261/361*

*UK Model
E Model
Australian Model
Chinese Model
CDP-361*

SUPPLEMENT-1

**Subject : 1. MODEL IDENTIFICATION CHANGED
2. PARTS CHANGED
3. MODEL ADDITION (CDP-361 : Chinese model)
4. BD BOARD CHANGED
5. ELECTRICAL BLOCK CHECKING (for BU-5BD20)**

(ECN-CD500187)

- The two of base unit BU-5BD10 and BU-5BD20 in the CD section are used for this model.
Refer to this service manual supplement-1 for the BD board of a set used BU-5BD20, and to the service manual is issued previously for the BD board of a set used BU-5BD10.
- As for the following items, refer to "CDP-213/313 SUPPLEMENT-1 (9-960-070-81)". Besides, refer to "CDP-XA1ES SUPPLEMENT-1 (9-960-087-81)" for US model.
 1. Schematic Diagram — BD Section —
 2. Printed Wiring Boards — BD Section —
 3. IC Pin Function (IC101 CXD2545Q)
 4. ELECTRICAL PARTS LIST

1. MODEL IDENTIFICATION CHANGED

MODEL IDENTIFICATION

— BACK PANEL —

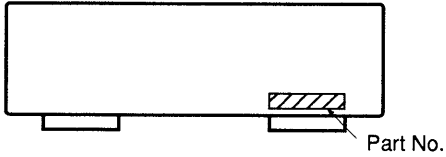

CDP-261

Destination	Product country	Part No.
US	CHINA	4-976-051-3□
		4-969-747-4□
AEP, East European	FRANCE	4-969-743-1□
German	FRANCE	4-969-743-9□

CDP-361

Destination	Product country	Part No.
US	CHINA	4-976-051-0□
		4-969-747-0□
AEP	CHINA	4-976-051-1□
		4-969-747-1□
AEP, East European	FRANCE	4-969-743-0□
UK	FRANCE	4-971-521-1□
E	CHINA	4-976-051-2□
		4-969-747-2□
		4-969-747-3□
Australian	CHINA	4-976-052-2□
		4-973-614-0□
German	FRANCE	4-969-743-8□
Chinese	CHINA	4-976-052-3□
		4-973-614-1□

2. PARTS CHANGED

Page	FORMER			NEW		
	Ref.No	Part No	Description	Ref.No	Part No	Description
24	** EXPLODED VIEWS **			** EXPLODED VIEWS **		
	* 52	4-969-747-01	PANEL, BACK (Made in CHINA) (361:US)	* 52	4-976-051-01	PANEL, BACK (Made in CHINA) (361:US)
	* 52	4-969-747-11	PANEL, BACK (Made in CHINA) (361:AEP)	* 52	4-976-051-11	PANEL, BACK (Made in CHINA) (361:AEP)
	* 52	4-973-747-21	PANEL, BACK (Made in CHINA) (361:E)	* 52	4-976-051-21	PANEL, BACK (Made in CHINA) (361:E)
	* 52	4-973-747-41	PANEL, BACK (Made in CHINA) (261:US)	* 52	4-976-051-31	PANEL, BACK (Made in CHINA) (261:US)
	* 52	4-973-614-01	PANEL, BACK (Made in CHINA) (361:AUS)	* 52	4-976-052-21	PANEL, BACK (Made in CHINA) (361:AUS)
29	** MAIN BOARD **			** MAIN BOARD **		
	IC201	8-752-858-69	IC CXP82612-007Q	IC201	8-752-867-49	IC CXP82612-017Q

3. MODEL ADDITION (CDP-361: Chinese model)

For detailed CDP-361 (Chinese model), refer to CDP-361 (E model).

DIFFERENCE TABLE

Page	CDP-361 (E model)			CDP-361 (Chinese model)		
	Ref.No	Part No	Description	Ref.No	Part No	Description
24	** EXPLODED VIEWS **			** EXPLODED VIEWS **		
	* 52	4-976-051-21	PANEL, BACK (Made in CHINA)	* 52	4-976-052-31	PANEL, BACK (Made in CHINA)
	* 52	4-969-747-21	PANEL, BACK (Made in CHINA)	* 52	4-973-614-11	PANEL, BACK (Made in CHINA)
	* 52	4-969-747-31	PANEL, BACK (Made in CHINA)			
	△53	1-569-007-11	ADAPTER, CONVERSION 2P (Made in CHINA)	△53	1-569-008-11	ADAPTER, CONVERSION 2P (Made in CHINA)
	△54	1-558-943-61	CORD, POWER (Made in CHINA)	△54	1-575-651-21	CORD, POWER (Made in CHINA)
	* 55	3-703-571-11	BUSHING (S) (4516), CORD (Made in CHINA)	* 55	3-703-244-00	BUSHING (2104), CORD (Made in CHINA)
	△S901	1-572-675-11	SWITCH, POWER VOLTAGE CHANGE (VOLTAGE SELECTOR) (Made in CHINA)			
	△T901	1-426-622-11	TRANSFORMER, POWER (Made in CHINA)	△T901	1-423-979-11	TRANSFORMER, POWER (Made in CHINA)
31	** MISCELLANEOUS **			** MISCELLANEOUS **		
	△53	1-569-007-11	ADAPTER, CONVERSION 2P (Made in CHINA)	△53	1-569-008-11	ADAPTER, CONVERSION 2P (Made in CHINA)
	△54	1-558-943-61	CORD, POWER (Made in CHINA)	△54	1-575-651-21	CORD, POWER (Made in CHINA)
	△S901	1-572-675-11	SWITCH, POWER VOLTAGE CHANGE (VOLTAGE SELECTOR) (Made in CHINA)			
	△T901	1-426-622-11	TRANSFORMER, POWER (Made in CHINA)	△T901	1-423-979-11	TRANSFORMER, POWER (Made in CHINA)

The components identified by mark △ or dotted line with mark △ are critical for safety. Replace only with part number specified.

4. BD BOARD CHANGED

- The BD board has two kinds of production, French and Chinese.
Therefore, the producing district can be found in "MODEL IDENTIFICATION" on page 2.

BU-5BD20 DIFFERENCE TABLE

 : CHANGED PORTION

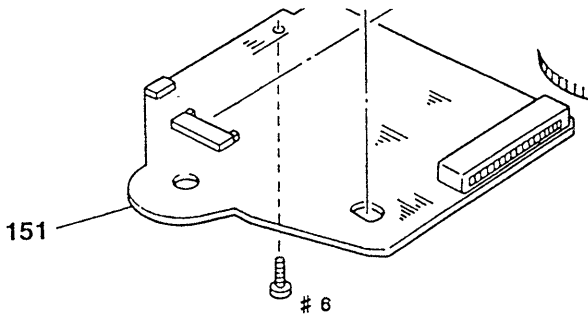
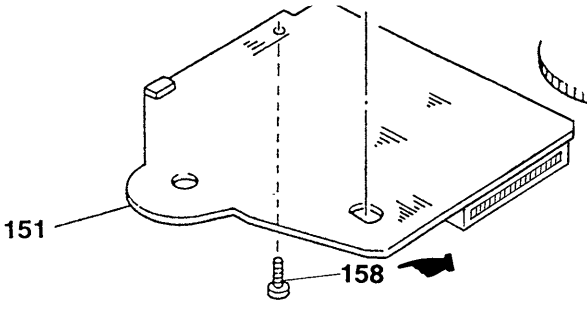
Page	BU-5BD10B			BU-5BD20		
	Ref.No	Part No	Description	Ref.No	Part No	Description
26	** EXPLODED VIEWS **			** EXPLODED VIEWS **		
	* 151	A-4649-946-A	BD BOARD, COMPLETE (Made in CHINA)	* 151	A-4673-509-A	BD BOARD, COMPLETE (Made in CHINA)
	* 151	A-4649-430-A	BD BOARD, COMPLETE (Made in FRANCE)	* 151	A-4673-511-A	BD BOARD, COMPLETE (Made in FRANCE)
	152	4-951-940-11	INSULATOR (BU)	152	4-951-940-01	INSULATOR (BU)
	Δ 154	8-848-144-11	OPTICAL PICK-UP KSS-240A	Δ 154	8-848-367-11	OPTICAL PICK-UP KSS-213B/K-N
	157	1-575-001-11	WIRE, FLAT TYPE (12 CORE)	157	1-769-069-11	WIRE (FLAT TYPE) (16 CORE)
	#6	7-685-134-19	SCREW +BTP 2.6X8 TYPE 2 N-S	158	4-951-620-01	SCREW (2.6X8), +BTP (Made in CHINA)
						
31	** MISCELLANEOUS **			** MISCELLANEOUS **		
	Δ 154	8-848-144-11	OPTICAL PICK-UP KSS-240A	Δ 154	8-848-367-11	OPTICAL PICK-UP KSS-213B/K-N
	157	1-575-001-11	WIRE, FLAT TYPE (12 CORE)	157	1-769-069-11	WIRE (FLAT TYPE) (16 CORE)

• Base Unit Change

As the base unit BU-5BD10 has changed to BU-5BD20, IC201 of the MAIN BOARD has changed.
The interchangeability between IC201 and BD BOARD is as below:

		MAIN BOARD IC201	
		FORMER	NEW
		8-752-858-69 CXP82612-007Q	8-752-867-49 CXP82612-017Q
Base Unit Type	BU-5BD10	○	○
	BU-5BD20	×	○

The components identified by mark Δ or dotted line with mark Δ are critical for safety.
Replace only with part number specified.

5. ELECTRICAL BLOCK CHECKING (for BU-5BD20)

Note :

1. CD Block is basically constructed to operate without adjustment. Therefore, check each item in order given.
2. Use YEDS-18 disc (3-702-101-01) unless otherwise indicated.
3. Use an oscilloscope with more than 10MΩ impedance.
4. Clean an object lens by an applicator with neutral detergent when the signal level is low than specified value with the following checks.

S Curve Check

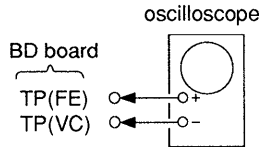

Procedure :

1. Connect oscilloscope to test point TP (FE) on BD board.
2. Connect between test point TP (TEI) and TP (VC) by lead wire.
3. Turned Power switch on.
4. Put disc (YEDS-18) in and turned Power switch on again and actuate the focus search. (actuate the focus search when disc table is moving in and out.)
5. Check the oscilloscope waveform (S-curve) is symmetrical between A and B. And confirm peak to peak level within 3 ± 1 Vp-p.

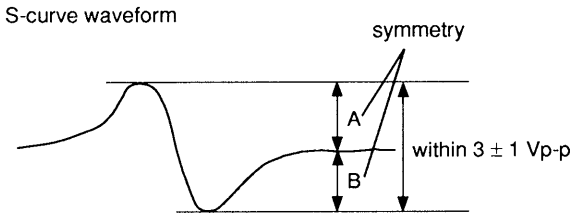

6. After check, remove the lead wire connected in step 2.
- Note :**
- Try to measure several times to make sure that the ratio of A : B or B : A is more than 10 : 7.
 - Take sweep time as long as possible and light up the brightness to obtain best waveform.

RF Level Check

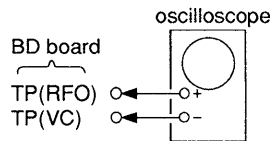

Procedure :

1. Connect oscilloscope to test point TP (RFO) on BD board.
2. Turned Power switch on.

3. Put disc (YEDS-18) in and playback.
4. Confirm that oscilloscope waveform is clear and check RF signal level is correct or not.

Note :

Clear RF signal waveform means that the shape “◇” can be clearly distinguished at the center of the waveform.

RF signal waveform

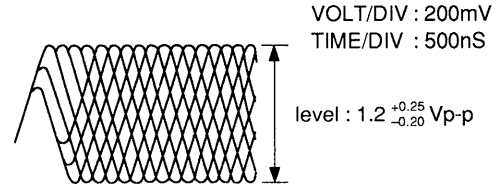

E-F Balance (1 Track Jump) Check

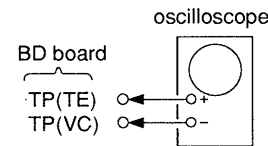

Procedure :

1. Connect oscilloscope to test point TP (TE) on BD board.
2. Turned Power switch on.
3. Put disc (YEDS-18) in to play the number five track.
4. Press the “II (pause)” button. (Becomes the 1 track jump mode)
5. Check the level B of the oscilloscope’s waveform and the A (DC voltage) of the center of the Traverse waveform. Confirm the following :
 $A/B \times 100 = \text{less than } \pm 20\%$.

1 track jump waveform

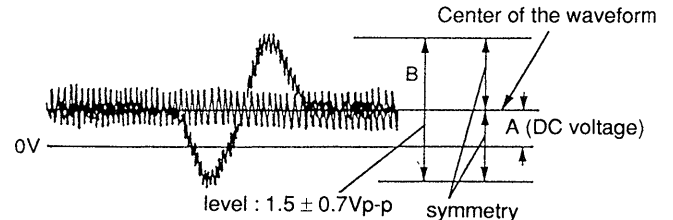

RF PLL Free-run Frequency Check

Procedure :

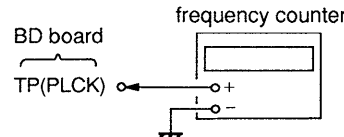
1. Connect frequency counter to test point (PCLK) with lead wire.
- 
2. Turned Power switch on.
 3. Confirm that reading on frequency counter is 4.3218MHz.

Adjustment Location :

[BD BOARD]

— Conductor side —

