

CDP-297/397

SERVICE MANUAL

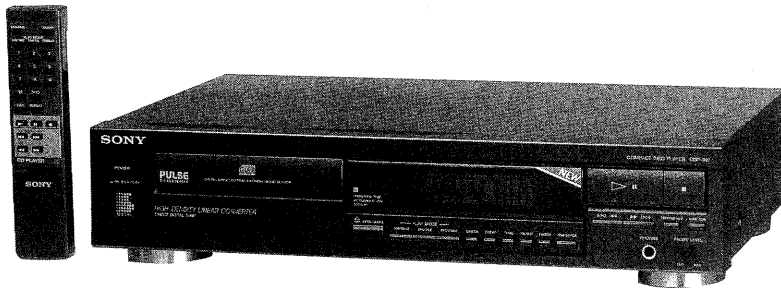

Photo: CDP-397

*US Model
Canadian Model
AEP Model
E Model
Australian Model
CDP-297*

*US Model
AEP Model
UK Model
Australian Model
CDP-397*

SPECIFICATIONS

Compact disc player

Frequency response	2 Hz to 20 kHz \pm 0.5 dB
Signal-to-noise ratio	More than 100 dB
Dynamic range	More than 98 dB
Harmonic distortion	Less than 0.0045%
Channel separation	More than 95 dB

Outputs

LINE OUT (phono jacks)	Output level 2 V (at 50 kilohms) Load impedance over 10 kilohms
PHONES (stereo phone jack)	Output level max. 10 mW Load impedance 32 ohms

General

Power requirements	AEP model: 220 - 230 V AC, 50/60 Hz US, Canadian model: 120 V AC, 60 Hz UK, Australian model: 240 V AC, 50/60 Hz E model: 110 - 120 V/220 - 240 V AC, adjustable with the voltage selector, 50/60 Hz
Power consumption	10 W
Dimensions (approx., including projections)	430 \times 100 \times 295 mm (w/h/d) (17 \times 4 \times 11 $\frac{5}{8}$ inches)
Weight (approx.)	3.5 kg (7 lbs 12 oz)

Remote commander (only for CDP-397) RM-D295

Remote control system	Infrared control
Power requirements	3 VDC with two R6 (size AA) batteries
Dimensions (approx., including projections)	40 \times 20 \times 175 mm (w/h/d) (1 $\frac{5}{8}$ \times $\frac{13}{16}$ \times 7 inches)
Weight (approx.)	95 g (4 oz)

Supplied accessories

Audio cord	(1) (2 phono plugs - 2 phono plugs)
Remote commander (only for CDP-397)	(1)
Sony SUM-3 (NS) batteries (only for CDP-397)	(2)
AC plug adaptor	(1) E model

Design and specifications are subject to change without notice.



COMPACT DISC PLAYER
SONY[®]

1. Laser Diode Properties
- Material: GaAlAs
 - Wavelength: 780 nm
 - Emission Duration: continuous

For the United Kingdom and European countries

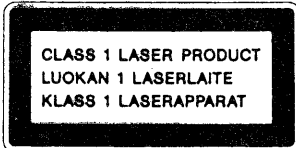

This Compact Disc player is classified as a CLASS 1 LASER product. The CLASS 1 LASER PRODUCT label is located on the rear exterior.

SAFETY-RELATED COMPONENT WARNING!!
COMPONENTS IDENTIFIED BY MARK \triangle OR DOTTED LINE WITH MARK \triangle ON THE SCHEMATIC DIAGRAMS AND IN THE PARTS LIST ARE CRITICAL TO SAFE OPERATION. REPLACE THESE COMPONENTS WITH SONY PARTS WHOSE PART NUMBERS APPEAR AS SHOWN IN THIS MANUAL OR IN SUPPLEMENTS PUBLISHED BY SONY.

ATTENTION AU COMPOSANT AYANT RAPPORT À LA SÉCURITÉ!
LES COMPOSANTS IDENTIFIÉS PAR UNE MARQUE \triangle SUR LES DIAGRAMMES SCHÉMATIQUES ET LA LISTE DES PIÈCES SONT CRITIQUES POUR LA SÉCURITÉ DE FONCTIONNEMENT. NE REMPLACER CES COMPOSANTS QUE PAR DES PIÈCES SONY DONT LES NUMÉROS SONT DONNÉS DANS CE MANUEL OU DANS LES SUPPLÉMENTS PUBLIÉS PAR SONY.

TABLE OF CONTENTS

<u>Section</u>	<u>Title</u>	<u>Page</u>
1. GENERAL		
	Location of Controls.....	4
2. DISASSEMBLY		5
3. PIN FUNCTIONS		
	IC101 (CXD2501Q).....	6
	IC301 (CXD2500Q).....	8
4. ELECTRICAL BLOCK CHECKING		10
5. DIAGRAMS		
	5-1. Block Diagram.....	12
	5-2. Semiconductor Lead Layouts.....	15
	5-3. Printed Wiring Boards.....	16
	5-4. Schematic Diagram.....	19
	5-5. IC Block Diagram.....	22
6. EXPLODED VIEWS		
	6-1. General.....	24
	6-2. Mechanism Section (CDM14L-5BD8A).....	26
	6-3. Pickup Section (BU-5BD8A).....	27
7. ELECTRICAL PARTS LIST		28

MODEL IDENTIFICATION

- Specification Label -

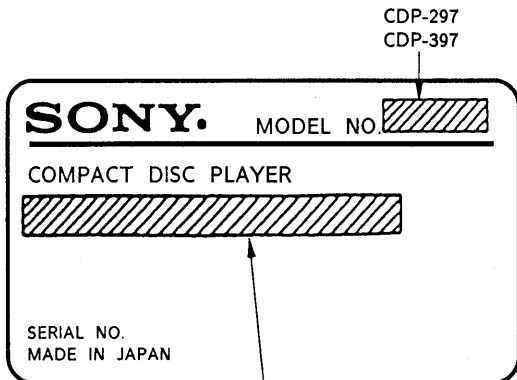

US, Canadian Model : AC 120V 60Hz 10W
 AEP, Germany Model: AC 220 - 230V ~ 50/60Hz
 UK, Australian Model: AC 240V ~ 50/60Hz
 E, Saudi Arabia Model : AC 110 - 120V, 220 - 240V,
 ~ 50/60Hz 10W

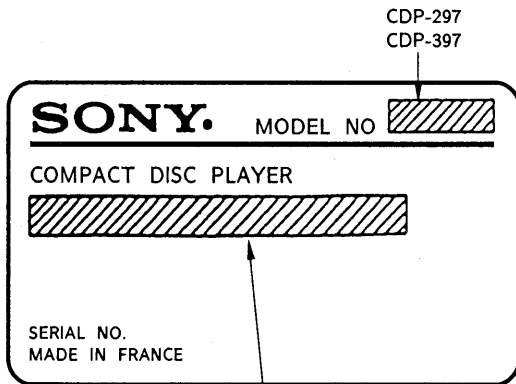

AEP, Germany Model: AC 220 - 230V ~ 50/60Hz
 UK Model: AC240V ~ 50/60Hz

NOTES ON HANDLING THE OPTICAL PICK-UP BLOCK OR BASE UNIT

The laser diode in the optical pick-up block may suffer electrostatic breakdown because of the potential difference generated by the charged electrostatic load, etc. on clothing and the human body.

During repair, pay attention to electrostatic breakdown and also use the procedure in the printed matter which is included in the repair parts.

The flexible board is easily damaged and should be handled with care.

NOTES ON LASER DIODE EMISSION CHECK

The laser beam on this model is concentrated so as to be focused on the disc reflective surface by the objective lens in the optical pick-up block. Therefore, when checking the laser diode emission, observe more than 30cm away from the objective lens.

SAFETY CHECK-OUT

After correcting the original service problem, perform the following safety check before releasing the set to the customer:

Check the antenna terminals, metal trim, "metallized" knobs, screws, and all other exposed metal parts for AC leakage. Check leakage as described below.

LEAKAGE TEST

The AC leakage from any exposed metal part to earth ground and from all exposed metal part to any exposed metal part having a return to chassis, must not exceed 0.5 mA (500 microamperes). Leakage current can be measured by any one of three methods.

1. A commercial leakage tester, such as the Simpson 229 or RCA WT-540A. Follow the manufacturers' instructions to use these instruments.
2. A battery-operated AC milliammeter. The Data Precision 245 digital multimeter is suitable for this job.
3. Measuring the voltage drop across a resistor by means of a VOM or battery-operated AC voltmeter. The "limit" indication is 0.75V, so analog meters must have an accurate low-voltage scale. The Simpson 250 and Sanwa SH-63Trd are examples of a passive VOM that is suitable. Nearly all battery operated digital multimeters that have a 2V AC range are suitable. (See Fig. A)

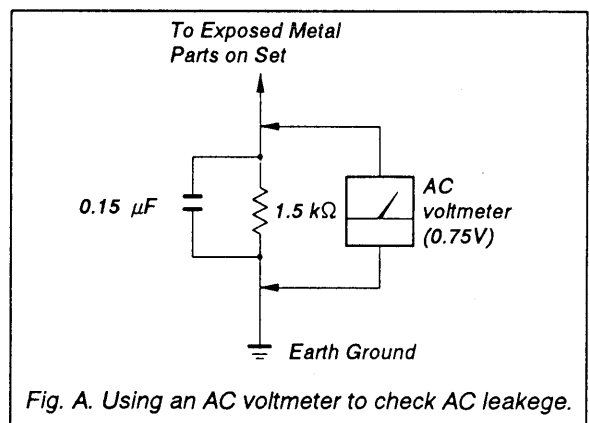
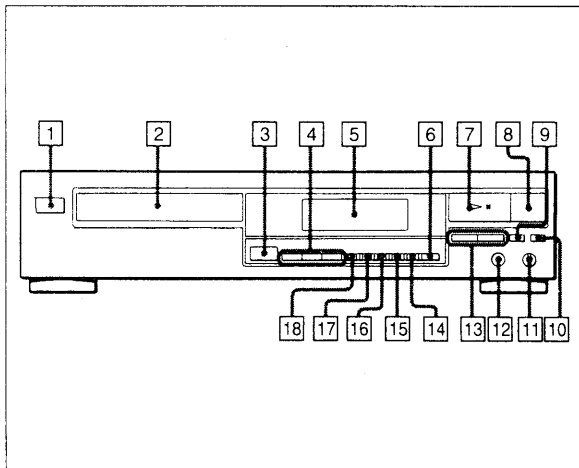

Fig. A. Using an AC voltmeter to check AC leakage.

SECTION 1 GENERAL

LOCATION OF CONTROLS

Front Panel



- 1 POWER switch
- 2 Disc tray
- 3 ▲ OPEN/CLOSE button
- 4 Play mode buttons
CONTINUE button
SHUFFLE button
PROGRAM button
- 5 Display window
- 6 PEAK SEARCH button
- 7 ►|| (play/pause) button
- 8 ■ (stop) button
- 9 EDIT/TIME FADE button
- 10 MUSIC SCAN button
- 11 PHONE LEVEL control
- 12 PHONES jack
- 13 |◀◀ ▶▶| (AMS*/RMS**) buttons
- 14 FADER button
- 15 REPEAT button
- 16 TIME button
- 17 CLEAR (program clear) button
- 18 CHECK (program check) button

* AMS is the abbreviation of Automatic Music Sensor
**RMS is the abbreviation of Random Music Sensor.

Remote Commander (only for CDP-397)

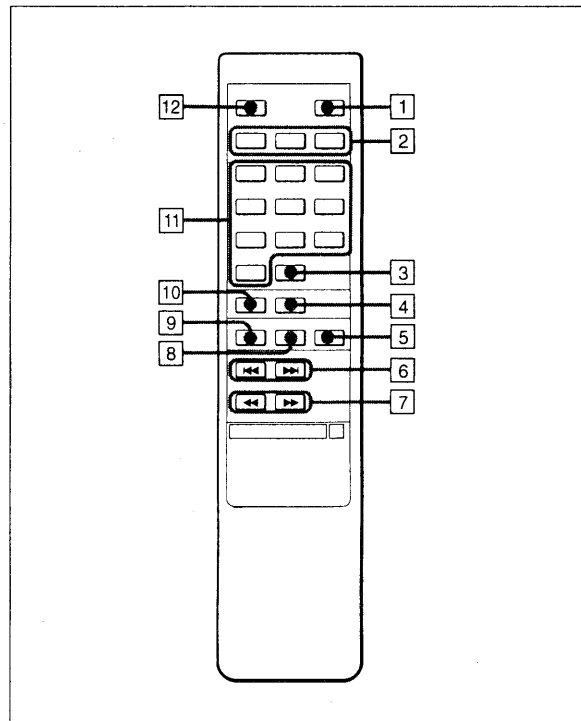

- 1 FADER button
- 2 Play mode buttons
CONTINUE button
SHUFFLE button
PROGRAM button
- 3 >10 (over 10) button
- 4 REPEAT button
- 5 ■ (stop) button
- 6 |◀◀ ▶▶| (AMS*) buttons
- 7 ◀◀ ▶▶ (manual search) buttons
- 8 || (pause) button
- 9 ► (play) button
- 10 TIME button
- 11 Numeric buttons
- 12 M. SCAN button

SECTION 2 DISASSEMBLY

Note: Follow the disassembly procedure in the numerical order given.

- ❶ Turn the cam to the direction of arrow (Counter clock wise) by minus screw driver.
- ❷ Take off the disc table.
- ❸ Remove the yoke bracket.
- ❹ Remove the MD (BU-5BD8A) to the direction of arrow.

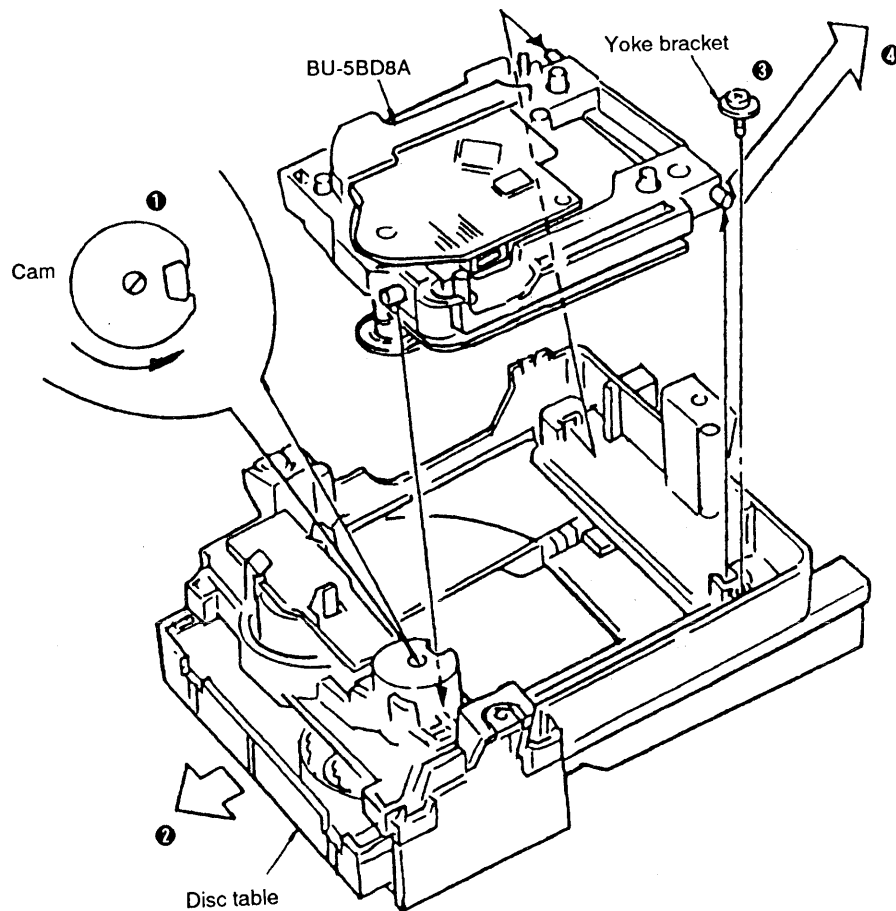

SECTION 3 PIN FUNCTIONS

• IC101 (CXD2501Q) PIN FUNCTION

Pin No.	Pin Name	I/O	Function
1	ADII	I	A/D signal input.
2	ADIO	O	Analog switch output.
3	RF	I	RF signal input.
4	TE	I	Tracking error signal input.
5	SE	I	SE signal input.
6	NC		Not used.
7	FE	I	Focus error signal input.
8	VC	I	Center voltage (2.5V) input.
9	DVss		Digital GND.
10	NC		Not used.
11	ATSK		
12	NC		
13	DFSW	I	Prevents the DFCT circuit from operating at "H".
14	DFCT	O	DFCT signal output.
15	XTAL	I	Master clock signal input.
16	NC		Not used.
17	XTSL	I	Frequency switching of input master clock signal. 22 MHz at "H". 11 MHz at "L".
18	LOCK	I	Lock signal input.
19	FOK	O	Focus OK signal output.
20	MIRR	O	Mirror signal output.
21	CLK	I	Clock signal when transmitting data from micro processor.
22	NC		Not used.
23	XLT	I	Latch signal when transmitting data from micro processor.
24	DATA	I	Data from micro processor.
25	COUT	O	Track jump number count signal output.
26	NC		Not used.
27	DVDD		Digital +5V.
28	NC		Not used.
29	SENS	O	SENS signal output.
30	SCLK	I	Serial data reading clock.
31	NC		Not used.
32	DIRC	I	DIRC signal input.
33	XRST	I	Reset signal input.
34	SOCK		Not used.
35	XOLT		
36	SOUT		
37	NC		
38	SFDR	O	Sled drive signal output (FWD).
39	SRON		Not used.
40	SRDR	O	Sled drive signal output (REVERSE).
41	SFON		Not used.
42	NC		
43	DVss		Digital GND.
44	NC		Not used.

Pin No.	Pin Name	I/O	Function
45	TEST		Fixed at "L".
46	NC		Not used.
47	TRDF	O	Tracking drive signal output (FWD).
48	TRON		Not used.
49	TRDR	O	Tracking drive signal output (REVERSE).
50	TFON		Not used.
51	FFDR	O	Focus drive signal output (FWD).
52	FRON		Not used.
53	FRDR	O	Focus drive signal output (REVERSE).
54	FFON		Not used.
55	NC		
56	SSTP	I	Limit switch detection.
57	NC		Not used.
58	CDS	I	Used at "H".
59	NC		Not used.
60	DVDD		Digital +5V.
61	AVDD		Analog +5V.
62	IGEN		Input for the ope-amp current supply.
63	NC		Not used.
64	AVSS		Analog GND.

• IC301 (CXD2500QA) PIN FUNCTION

Pin No.	Pin Name	I/O	Function
1	FOK	I	Focus OK input pin. Used for SENS output and servo auto sequencer.
2	FSW	O	Spindle motor output filter switching output.
3	MON	O	Spindle motor ON-OFF control output.
4	MDP	O	Spindle motor servo control.
5	MDS	O	Spindle motor servo control.
6	LOCK	O	Samples GFS at 460 Hz, and outputs H when GFS is H. Outputs L if L continues eight times.
7	NC	—	
8	VCOO	O	Oscillation circuit output for analog EFM PLL.
9	VCOI	I	Oscillation circuit input for analog EFM PLL. f _{LOCK} =8.6436 MHz.
10	TEST	I	TEST pin. Normally GND.
11	PDO	O	Charge pump output for analog EFM and PLL.
12	Vss		GND
13	NC	—	
14	NC	—	
15	NC	—	
16	VPCO	O	PLL charge pump output for variable pitch.
17	VCKI	I	Clock input from the external VCO for variable pitch. f _{Center} =16.9344 MHz.
18	FILO	O	Filter output for master PLL (Slave=Digital PLL).
19	FILI	I	Filter input for master PLL.
20	PCO	O	PLL charge pump output for master PLL.
21	AVss		Analog GND
22	CLTV	I	Master VCO control voltage input.
23	AVDD		Analog power supply (+5V)
24	RF	I	EFM signal input.
25	BIAS	I	Asymmetry circuit regulated current input.
26	ASYI	I	Asymmetry comparative voltage input.
27	ASYO	O	EFM full swing output (L=Vss, H=VDD)
28	ASYE	I	L:Asymmetry circuit OFF H:Asymmetry circuit ON.
29	NC	—	Not used.
30	PSSL	I	Audio data output mode switching input. Serial output at L, parallel output at H.
31	WDCK	O	D/A interface for 48 bit slot. Word-clock f=2Fs.
32	LRCK	O	D/A interface for 48 bit slot. LR clock f=Fs.
33	VDD		Power supply (+5V).
34	DA16	O	DA16 (MSB) output when PSSL=1. 48 bit slot serial data when PSSL=0 (2s'COMP, MSB first).
35	DA15	O	DA15 output when PSSL=1. 48 bit slot bit clock when PSSL=0.
36	DA14	O	DA14 output when PSSL=1. 64 bit slot serial data when PSSL=0 (2s'COMP, LSB first)
37	DA13	O	DA13 output when PSSL=1. 64 bit slot bit clock when PSSL=0.
38	DA12	O	DA12 output when PSSL=1. 64 bit slot LR clock when PSSL=0.
39	DA11	O	DA11 output when PSSL=1. G _{TOP} output when PSSL=0.
40	AD10	O	DA10 output when PSSL=1. XUGF output when PSSL=0.
41	DA09	O	DA09 output when PSSL=1. XPLCK output when PSSL=0.
42	DA08	O	DA08 output when PSSL=1. GFS output when PSSL=0.
43	DA07	O	DA07 output when PSSL=1. RFCK output when PSSL=0.
44	DA06	O	DA06 output when PSSL=1. C2P0 output when PSSL=0.
45	DA05	O	DA05 output when PSSL=1. XRAOF output when PSSL=0.

Pin No.	Pin Name	I/O	Function
46	DA04	O	DA04 output when PSSL=1. MNT3 output when PSSL=0.
47	DA03	O	DA03 output when PSSL=1. MNT2 output when PSSL=0.
48	DA02	O	DA02 output when PSSL=1. MNT1 output when PSSL=0.
49	DA01	O	DA01 output when PSSL=1. MNT0 output when PSSL=0.
50	APTR	O	Aperture correction control output. H when Rch.
51	APTL	O	Aperture correction control output. H when Lch.
52	Vss		GND
53	XTAI	I	16.9344 MHz crystal oscillation circuit input. Or 33.8688 MHz input.
54	XTAO	O	16.9344 MHz crystal oscillation circuit input.
55	XTSL	I	Crystal selection input pin. Set to L when crystal is 16.9344 MHz. Set to H when 33.8688 MHz.
56	FSTT	O	2/3 frequency division output of Pins ⑤ and ⑥. Will not change by variable pitch.
57	C4M	O	4.2336 MHz output. Varies simultaneously with pitch.
58	C16M	O	16.9344 MHz output. Varies simultaneously with pitch.
59	MD2	I	Digital-Out ON/OFF control. ON at H, OFF at L.
60	DOUT	O	Digital-Out output pin.
61	EMPH	O	Outputs H if emphasis is present in the playback disc. Outputs L when it is absent.
62	WFCK	O	WFCK (Write Frame Clock) output.
63	SCOR	O	Outputs H when either sub-code sync S0 or S1 has been detected.
64	SBSO	O	SubP to W serial output.
65	EXCK	I	SBSO read-out clock input.
66	SQSO	O	SubQ 80 bit and PCM peak level data 16 bit output.
67	SQCK	I	SQSO read-out clock input.
68	MUTE	I	Mute at H, release at L.
69	SENS	—	SENS output. Outputs to CPU.
70	XRST	I	System reset. Resets at "L".
71	DATA	I	Serial data input from CPU.
72	XLAT	I	Latch input from CPU. Latches the serial data at falling.
73	VDD		Power supply (+5V).
74	CLOK	I	Serial data transmission clock input from CPU.
75	SEIN	I	SENS input from SSP.
76	CNIN	I	Track jump number count signal input.
77	DATO	O	Outputs the serial data to SSP.
78	XLTO	O	Outputs the serial data latch to SSP. Latches at falling.
79	CLKO	O	Outputs the serial data transmission clock to SSP.
80	MIRR	I	Mirror signal input. Uses for a jump above 128 track with auto sequencer. 1, 0

SECTION 4 ELECTRICAL BLOCK CHECKING

Note :

1. CD Block basically constructed to operate without adjustment. Therefore, check each item in order given.
2. Use YEDS-18 disc (3-702-101-01) unless otherwise indicated.
3. Use the oscilloscope with more than $10M\Omega$ impedance.
4. Clean an object lens by an applicator with neutral detergent when the signal level is low than specified value with the following checks.

S-Curve Check

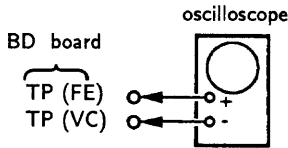

Procedure :

1. Connect oscilloscope to test point TP (FE) on BD board.
2. Connect between test point TP (FEI) and TP (VC) by lead wire.
3. Turned Power switch on and actuate the focus search. (actuate the focus search when disc table is moving in and out.)
4. Check the oscilloscope waveform (S-curve) is symmetrical between A and B. And confirm peak to peak level within $3\pm 1V_{p-p}$.

S-curve waveform

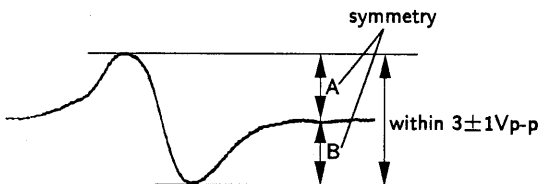

5. After check, remove the lead wire connected in step 2.
- Note :**
- Try to measure several times to make sure that the ratio of A : B or B : A is more than 10 : 7.
 - Take sweep time as long as possible and light up the brightness to obtain best waveform.

RF Level Check

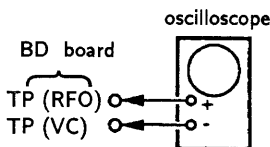

Procedure :

1. Connect oscilloscope to test point TP (RFO) on BD board.
2. Turn Power switch on.
3. Put disc (YEDS-18) in and playback.
4. Confirm that oscilloscope waveform is clear and check RF signal level is correct or not.

Note :

Clear RF signal waveform means that the shape "◇" can be clearly distinguished at the center of the waveform.

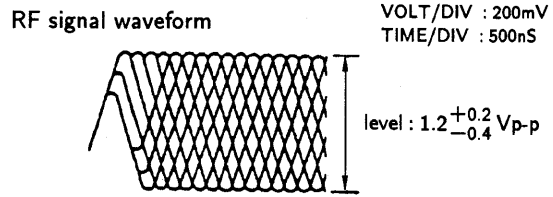

E-F Balance Check

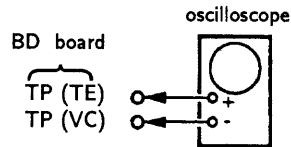

Procedure :

1. Connect test point TP (ADJ) to ground and TP (TEI) to TP (VC) with lead wire.
2. Connect oscilloscope to test point TP (TE) on BD board.
3. Turn Power switch on.
4. Put disc (YEDS-18) in and playback.
5. Confirm that the oscilloscope waveform is symmetrical on the top and bottom in relation to 0V, and check this level.

Traverse oscilloscope



6. Remove the lead wire connected in step 1.

RF PLL Free-run Frequency Check

Procedure :

1. Connect frequency counter to test point (PCK) with lead wire.

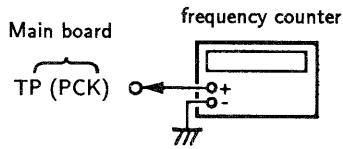

2. Turn Power switch on.
3. Confirm that reading on frequency counter is 4.3218 MHz.

Adjustment Location :

【BD BOARD】

- Conductor side -

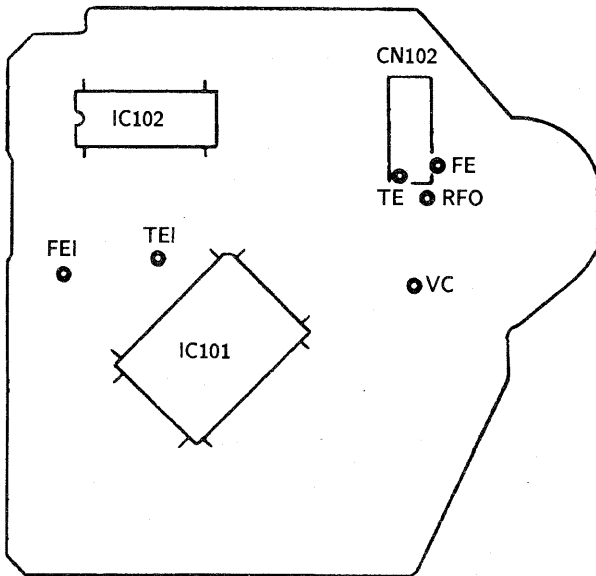

【MAIN BOARD】

- Conductor side -

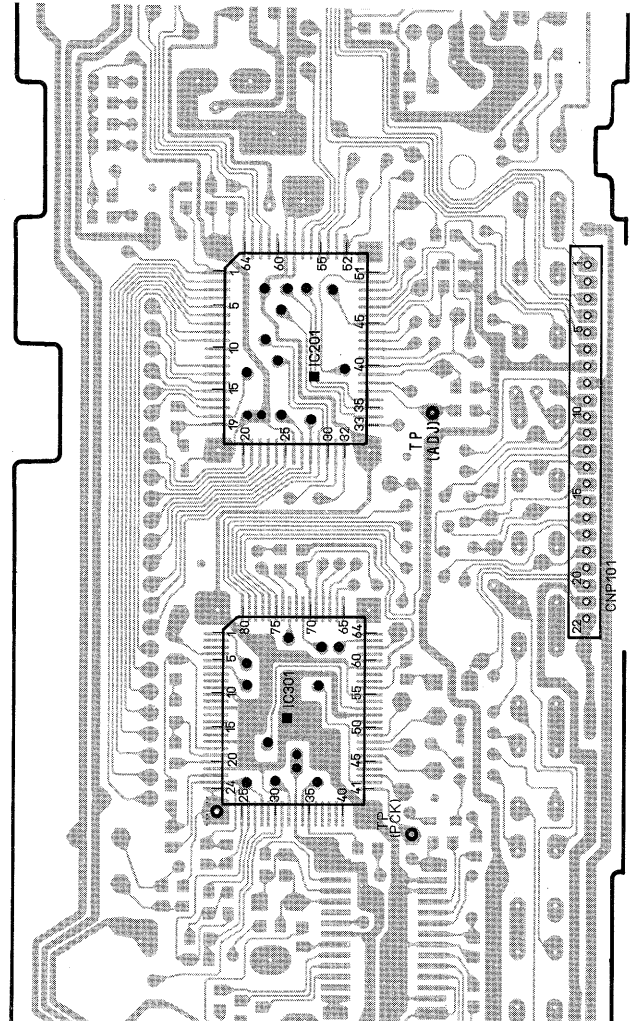

SECTION 5
DIAGRAMS

5-1. BLOCK DIAGRAM

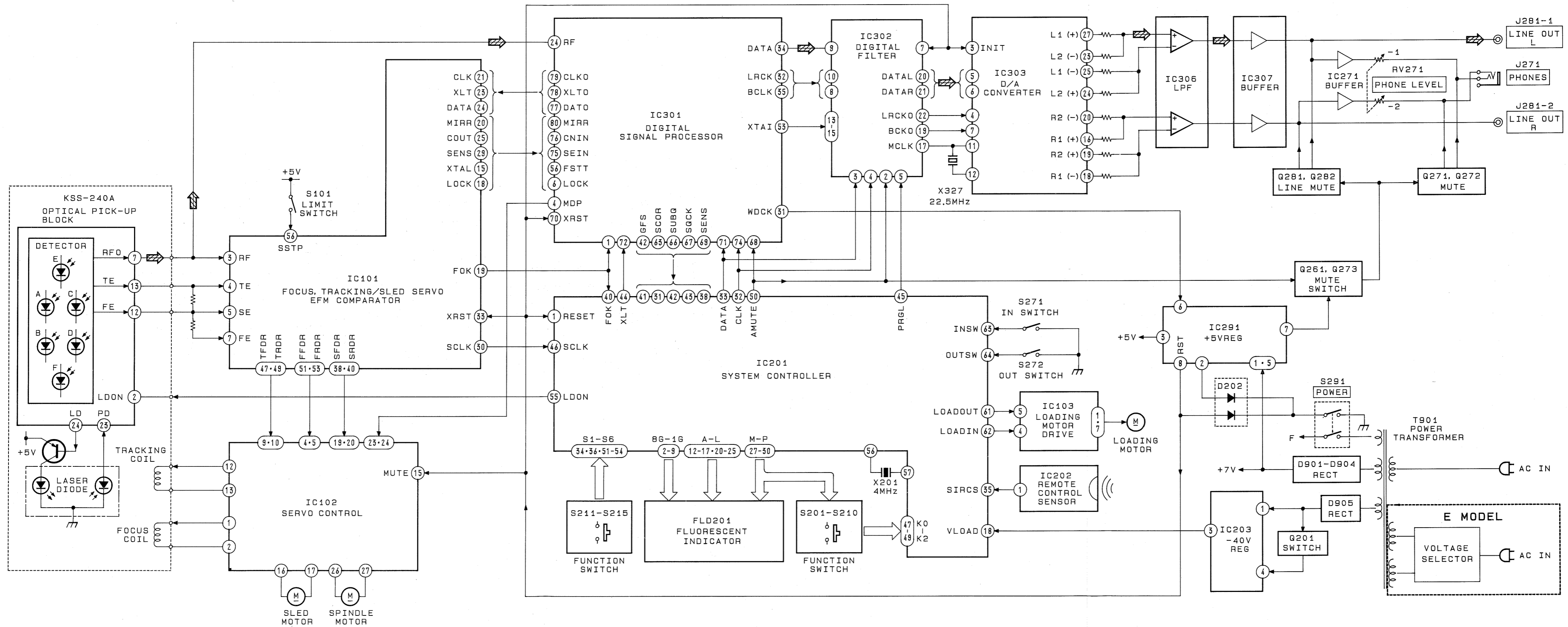

5-2. SEMICONDUCTOR LEAD LAYOUTS

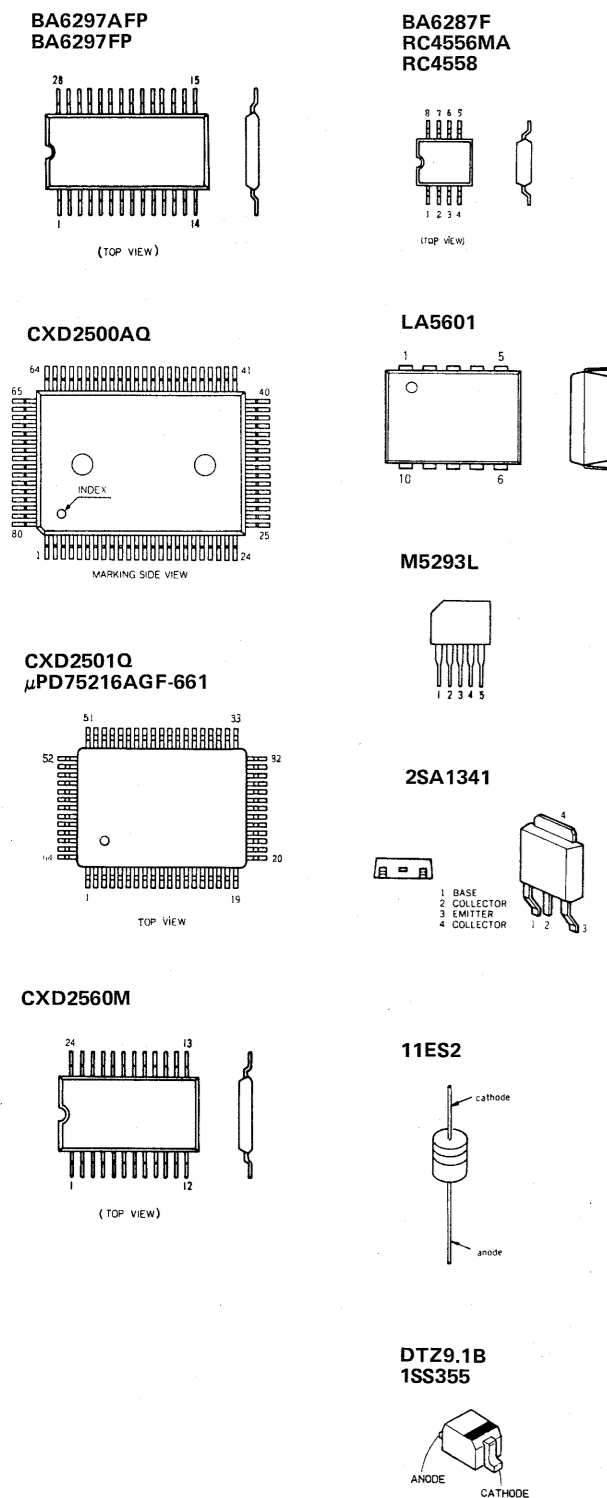

5-3. PRINTED WIRING BOARDS

● Semiconductor Location

Ref.No.	Location	Ref.No.	Location
D201	E-10	IC103	B-16
D202	D-11	IC201	D-8
D212	D-8	IC202	D-10
D221	E-10	IC271	D-2
D222	E-10	IC291	E-4
D223	E-7	IC301	D-7
D224	E-6	IC302	E-6
D261	D-2	IC303	D-4
D292	D-3	IC306	C-3
D328	E-4	IC307	C-3
D901	G-4		
D902	G-3	Q201	E-10
D903	G-4	Q261	D-3
D904	G-4	Q271	D-1
D905	G-4	Q272	D-1
		Q273	D-3
IC101	C-15	Q281	C-2
IC102	B-15	Q282	C-2

Note

- : parts mounted on the conductor side.
- : Through hole.
- : Pattern on the side which is seen.
- : Pattern of the rear side
- : Chip components extracted from the rear side.

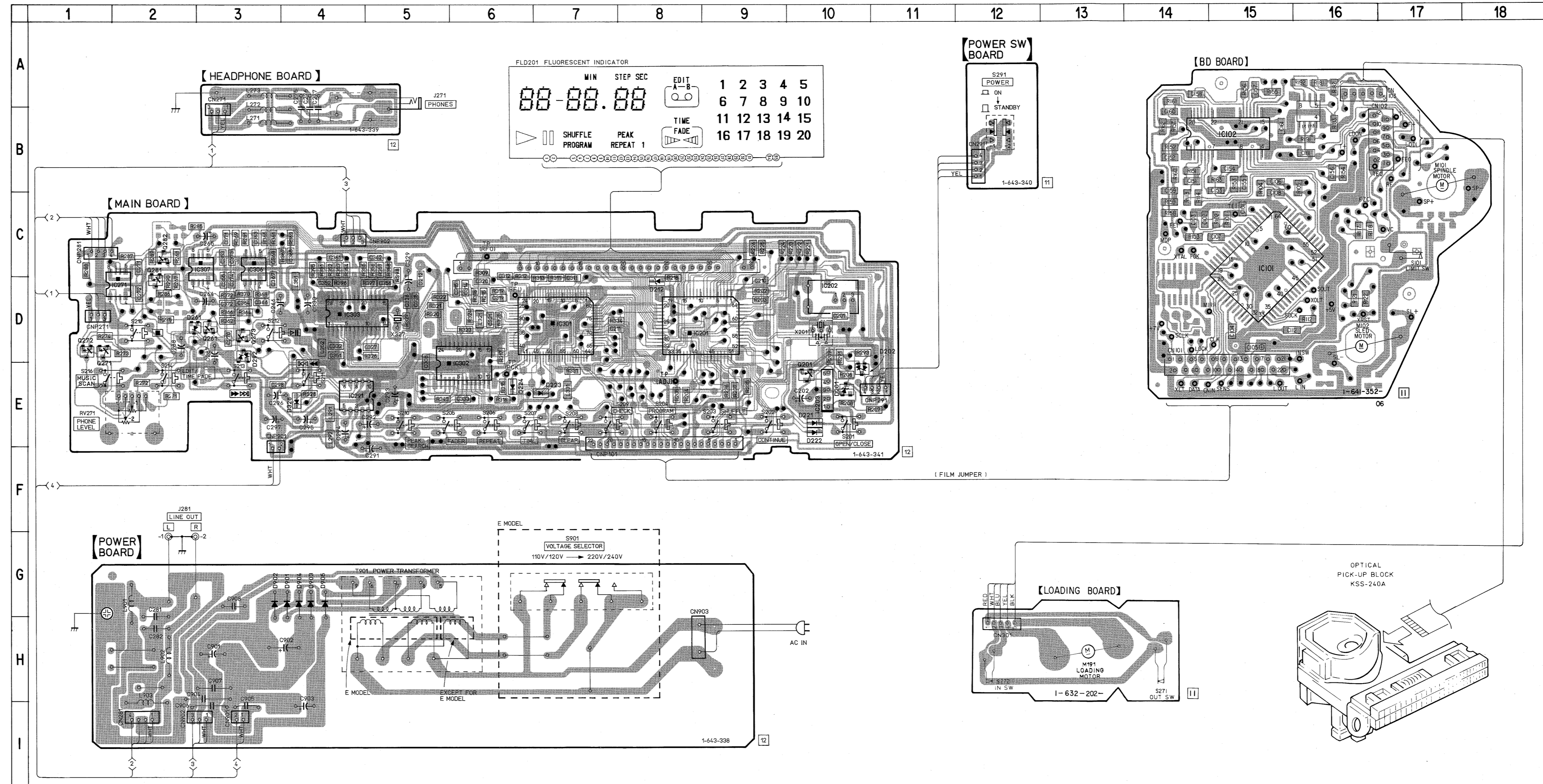

A
B
C
D
E
F
G
H
I
J
K
L
M
N
O
P

5.4. SCHEMATIC DIAGRAM

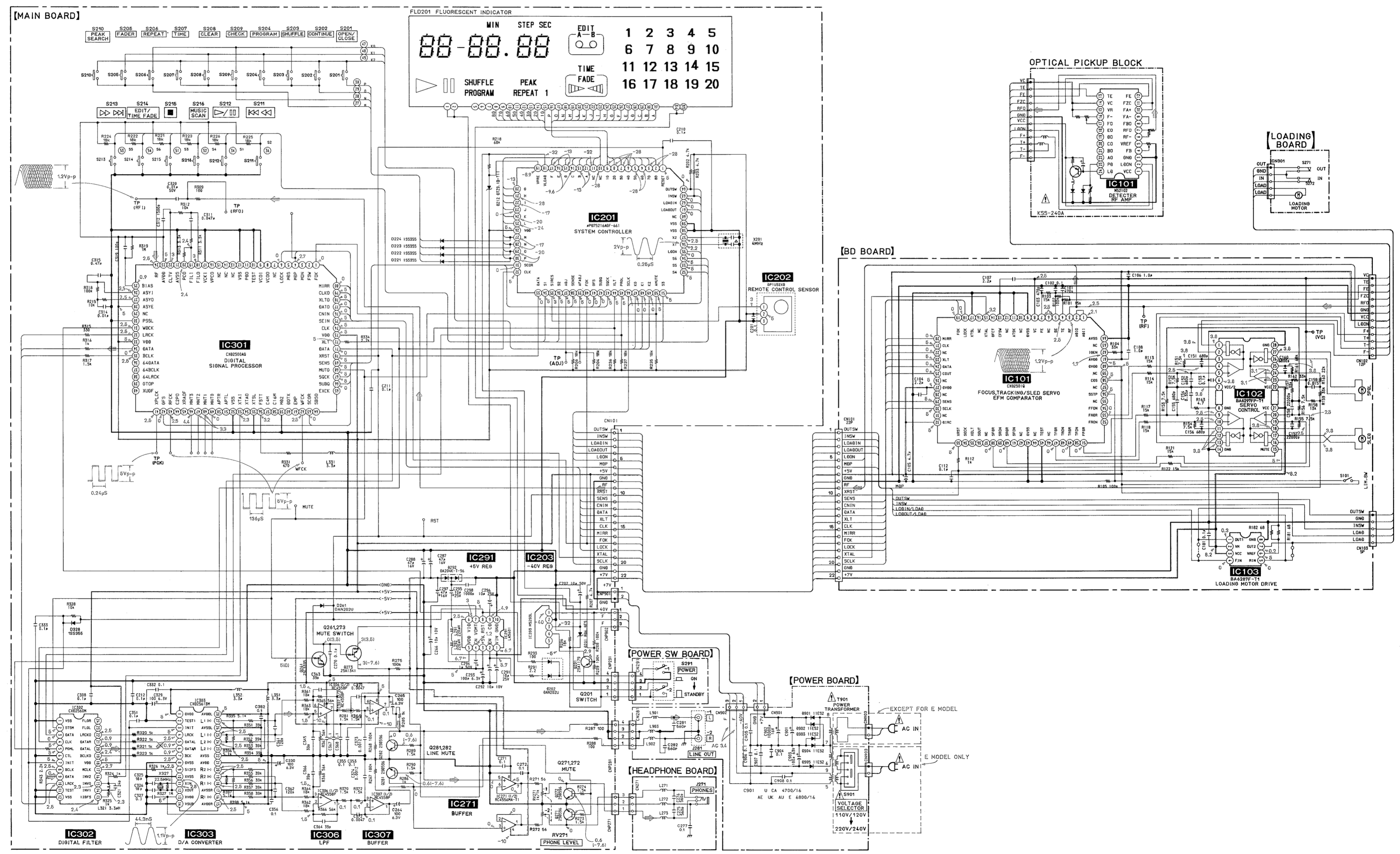

Note:

- All capacitors are in μF unless otherwise noted. pF : μF 50WV or less are not indicated except for electrolytics and tantalums.
- All resistors are in Ω and $\frac{1}{2}\text{W}$ or less unless otherwise specified.
- Δ : internal component.
- \ominus : B+ line.
- \ominus : B- line.
- Voltage and waveforms are dc with respect to ground under no-signal conditions.
- no mark: STOP
- (): PLAY
- Voltages are taken with a VOM. (Input impedance 10M Ω) Voltage variations may be noted due to normal production tolerances.
- Waveforms are taken with an oscilloscope. Voltage variations may be noted due to normal production tolerances.
- Signal path.
- \Rightarrow : CD

Note: The components identified by mark Δ or dotted line with mark Δ are critical for safety. Replace only with part number specified.

Note: Les composants identifiés par une marque Δ ou pointillés sont critiques pour la sécurité. Ne les remplacer que par une pièce portant le numéro spécifié.

5-5. IC BLOCK DIAGRAM

IC101 CXD2501Q

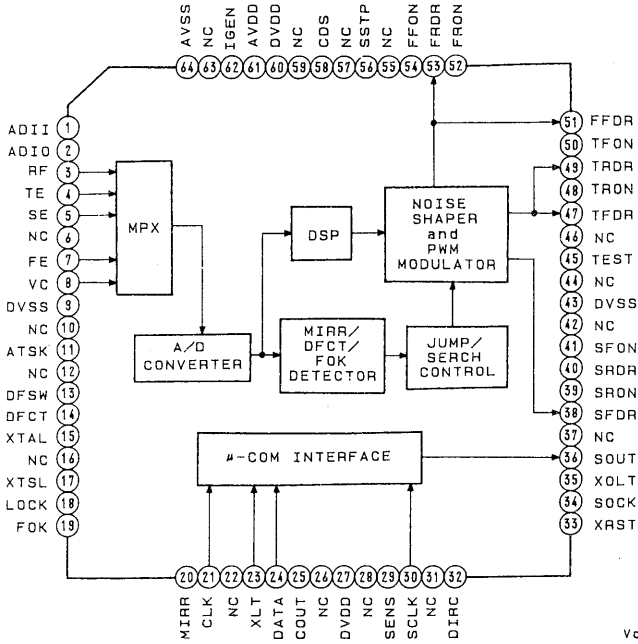

IC203 M5293L

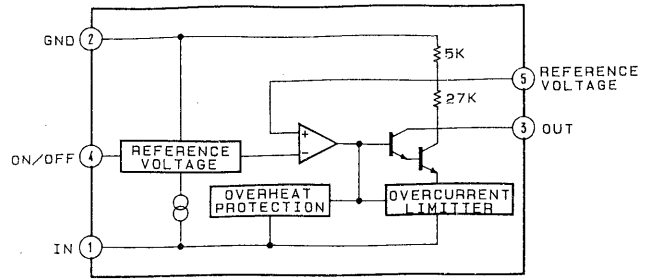

IC291 LA5601

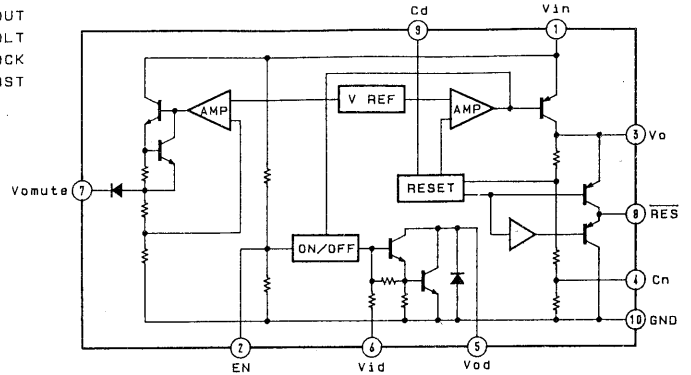

IC303 CXD2561M

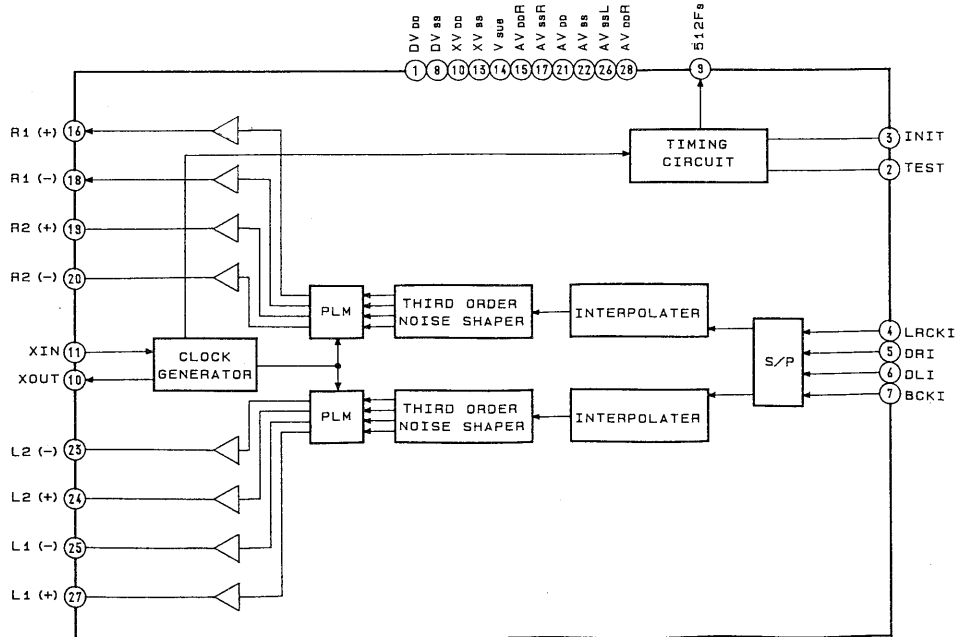

IC301 CXD2500AQ

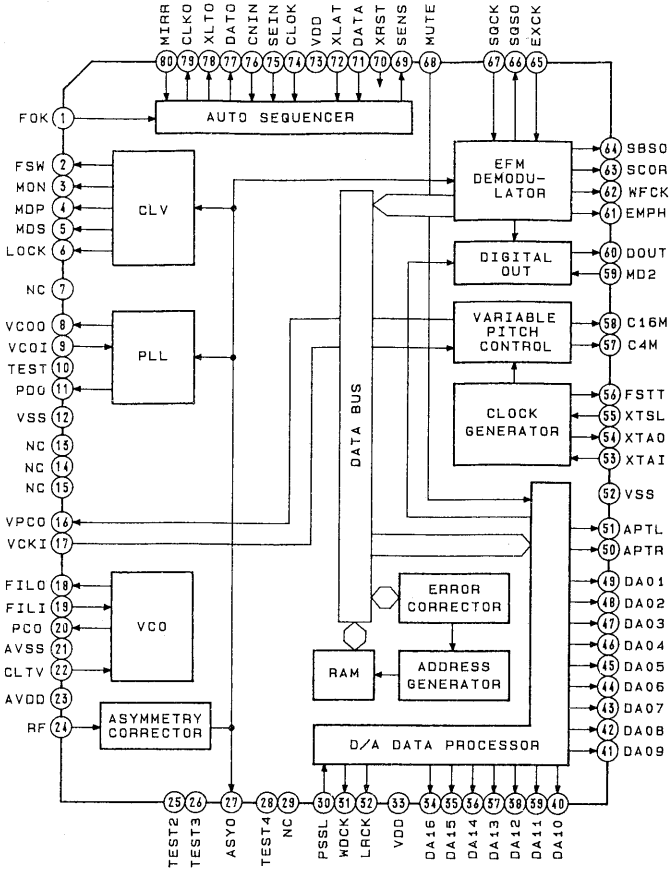

IC302 CXD2560M

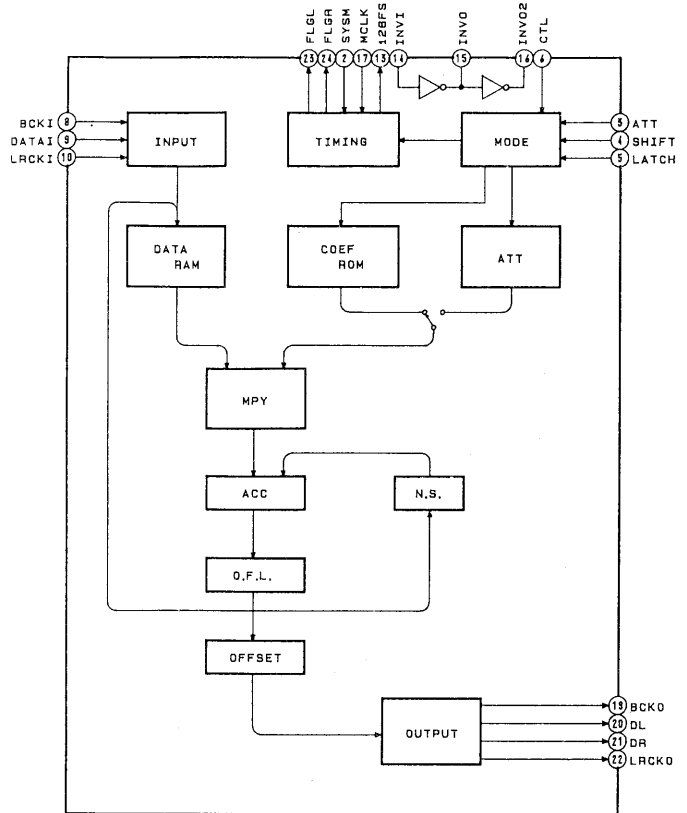

SECTION 6 EXPLODED VIEWS

NOTE:

- -XX, -X mean standardized parts, so they may have some differences from the original one.

- Color Indication of Appearance Parts
Example:

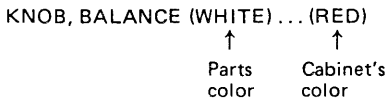

- Items marked "*" are not stocked since they are seldom required for routine service. Some delay should be anticipated when ordering these items.
- The mechanical parts with no reference number in the exploded views are not supplied.
- Hardware (# mark) list is given in the last of this parts list.

The components identified by mark or dotted line with mark are critical for safety. Replace only with part number specified.

Les composants identifiés par une marque sont critiques pour la sécurité. Ne les remplacer que par une pièce portant le numéro spécifié.

6-1. GENERAL

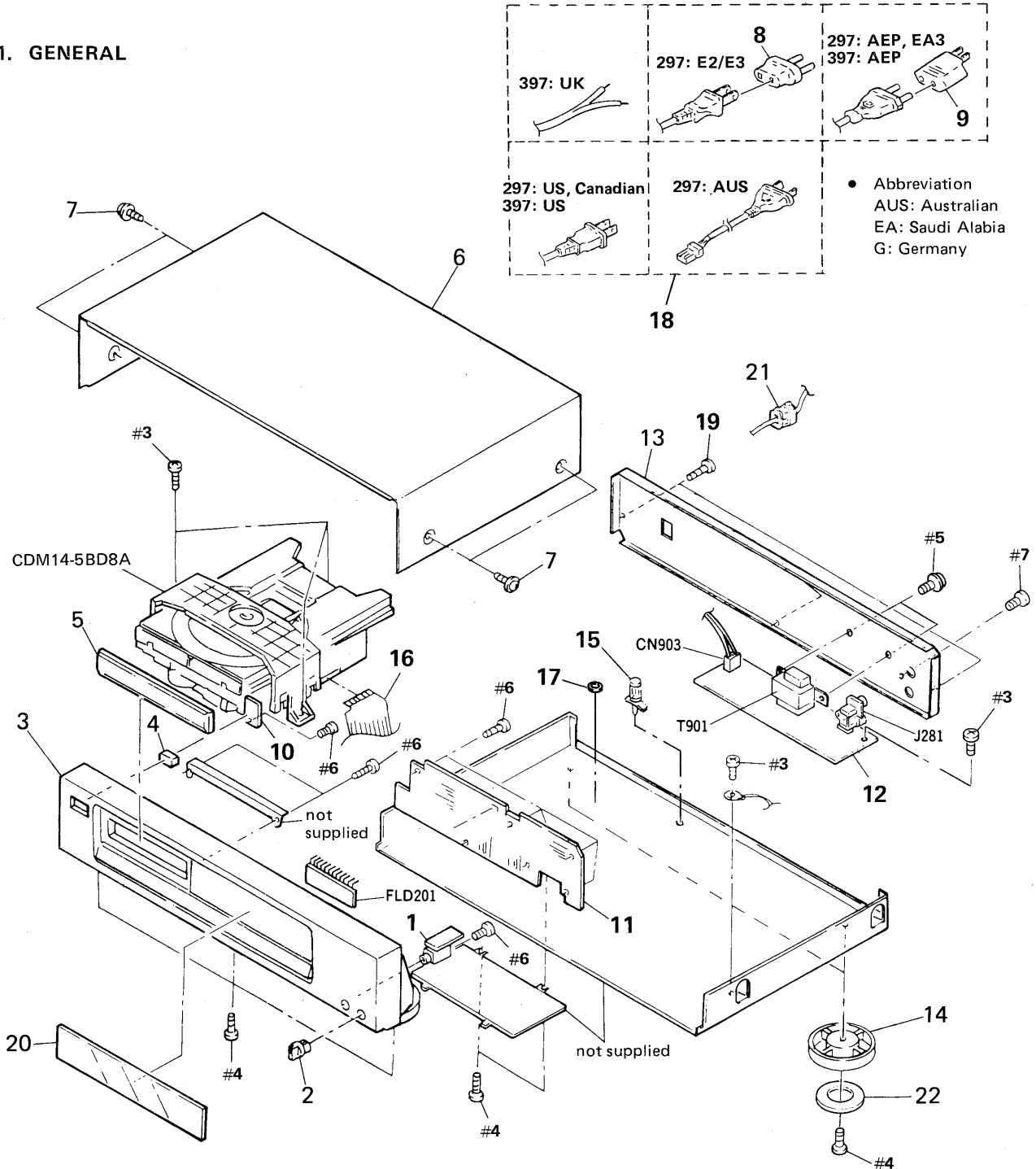

Ref. No.	Part No.	Description	Remark
* 1	1-643-339-11	HEADPHONE BOARD	
2	4-933-116-11	KNOB (C, TYPE), VOL	
3	X-4942-250-1	PANEL ASSY, FRONT (397:AEP, UK, AUS, G)	
3	X-4942-251-1	PANEL ASSY, FRONT (297:US, Canadian)	
3	X-4942-252-1	PANEL ASSY, FRONT (297:AEP, AUS, E, EA, G)	
3	X-4942-603-1	PANEL ASSY, FRONT (397:US)	
4	4-922-921-01	BUTTON (POWER)	
5	4-949-547-01	PANEL, LOADING (397)	
5	4-949-547-11	PANEL, LOADING (297)	
6	4-929-035-31	CASE	
7	3-704-366-31	SCREW (CASE) (M3X6)	
△8	1-569-007-11	ADAPTER, CONVERSION 2P (E)	
△9	1-569-008-11	ADAPTER, CONVERSION 2P (EA)	
* 10	1-643-340-11	POWER SW BOARD	
* 11	A-4649-223-A	MAIN BOARD, COMPLETE (UK)	
* 11	A-4649-224-A	MAIN BOARD, COMPLETE (297:AEP, AUS, Canadian, E, EA/397:AEP, AUS)	
* 11	A-4649-369-A	MAIN BOARD, COMPLETE (US)	
* 11	A-4649-374-A	MAIN BOARD, COMPLETE (G)	
12	1-643-338-11	POWER BOARD	
* 13	4-949-538-31	PANEL, BACK (397:US)	
* 13	4-949-538-01	PANEL, BACK (397:AEP, UK, G)	
* 13	4-949-539-02	PANEL, BACK (297:US)	
* 13	4-949-539-11	PANEL, BACK (297:AEP, G)	
* 13	4-949-539-21	PANEL, BACK (EA)	
* 13	4-949-539-31	PANEL, BACK (297:AUS)	
* 13	4-949-539-41	PANEL, BACK (297:Canadian/397:AUS)	

Ref. No.	Part No.	Description	Remark
14	4-943-148-42	FOOT (F58175SW) (297:AEP, E, AUS, EA, G/397:AEP, AUS, UK, G)	
14	4-943-148-32	FOOT (F58175SW) (297:US, Canadian/397:US)	
* 15	3-349-025-41	HOLDER, PC BOARD	
16	1-694-001-11	JUMPER, FILM (WITH TERMINAL)	
* 17	4-929-566-01	SPACER (CDM)	
△18	1-558-943-41	CORD, POWER (E)	
△18	1-558-946-21	CORD, POWER (UK)	
△18	1-574-358-31	CORD, POWER (WITH CONNECTOR) (AUS)	
△18	1-575-651-21	CORD, POWER (G)	
△18	1-575-651-21	CORD, POWER (397:AEP/297:AEP, EA)	
△18	1-590-836-11	CORD, POWER (297:US, Canadian/397:US)	
19	4-928-635-01	SCREW, +BV (2. 6X8) TAPPING	
20	4-939-706-61	PLATE, INDICATION (297)	
20	4-939-706-52	PLATE, INDICATION (397)	
* 21	3-703-244-00	BUSHING (2104), CORD (EXCEPT E)	
* 21	3-703-571-11	BUSHING (S) (4516), CORD (E)	
22	4-923-836-11	CUSHION	
△CN903	1-580-230-11	PIN CONNECTOR 3P, MALE	
FLD201	1-519-611-11	INDICATOR TUBE, FLUORESCENT	
J281	1-569-442-11	JACK, PIN 2P (LINE OUT)	
△T901	1-450-212-11	TRANSFORMER, POWER (297:US, Canadian/397:US)	
△T901	1-450-213-11	TRANSFORMER, POWER (297:AEP, AUS, G/397:AEP, AUS, UK, G)	
△T901	1-450-214-11	TRANSFORMER, POWER (E, EA)	

6-2. MECHANISM SECTION (CDM14L-5BD8A)

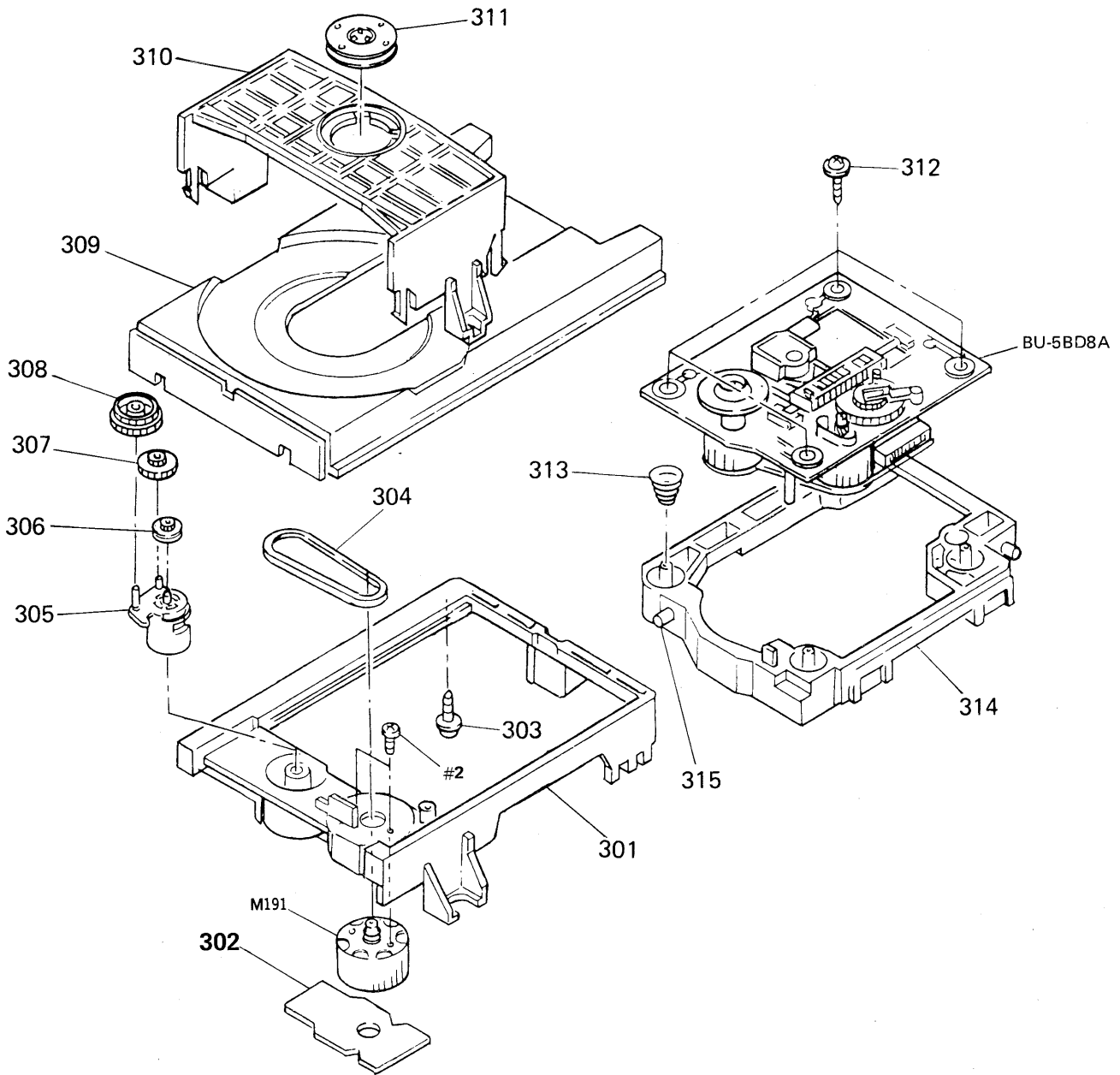



Ref. No.	Part No.	Description	Remark
301	4-933-111-01	CHASSIS (MD)	
* 302	1-632-202-11	LOADING BOARD	
* 303	4-917-583-21	BRACKET, YOKE	
304	4-927-649-01	BELT	
305	4-933-109-01	CAM	
306	4-927-651-01	PULLEY (S)	
307	4-927-628-01	GEAR (C)	
308	4-933-107-01	GEAR (PL)	

Ref. No.	Part No.	Description	Remark
309	4-933-112-01	TABLE, DISK	
310	4-933-110-01	HOLDER (MG)	
* 311	1-452-538-11	MAGNET	
312	4-933-134-01	SCREW (+PTPWH M2. 6X6)	
313	4-948-503-01	SPRING (BU), COMPRESSION	
314	4-933-129-01	HOLDER (BU)	
315	4-933-108-01	SHAFT (CAM)	
M191	A-4604-363-A	MOTOR (L) ASSY	

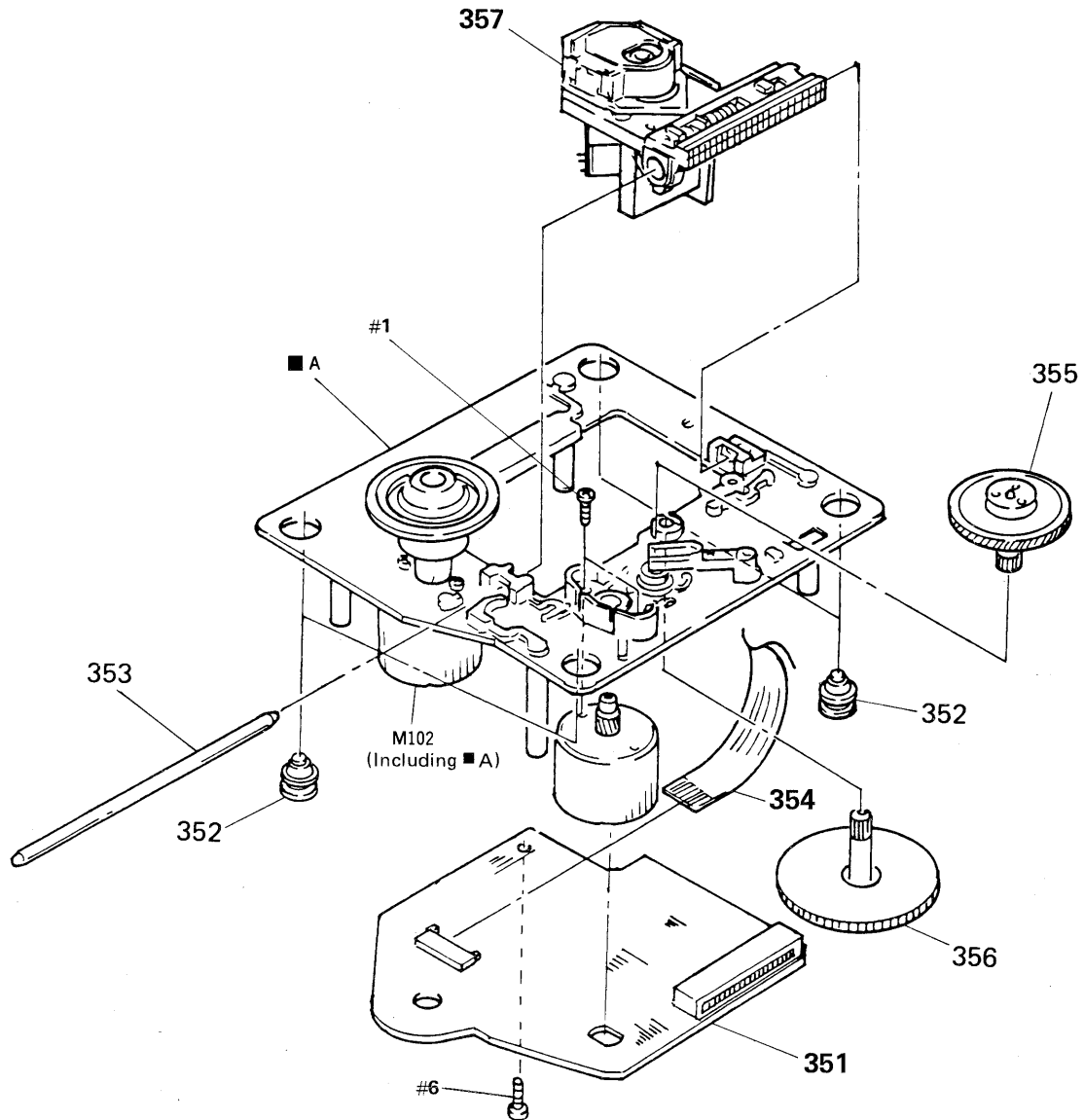
6-3. PICKUP SECTION (BU-5BD8A)



Ref. No.	Part No.	Description	Remark
* 351	A-4617-977-A	BD BOARD, COMPLETE (MADE IN JAPAN)	
* 351	A-4617-986-A	BD BOARD, COMPLETE (MADE IN FRANCE)	
	352	4-933-126-01 INSULATOR (A)	
	353	4-917-565-01 SHAFT, SLED	
	354	1-575-001-11 WIRE, FLAT TYPE (12 CORE)	
	355	4-917-567-01 GEAR (M)	
	356	4-917-564-01 GEAR (P), FLATNESS	
△357	8-848-144-11	DEVICE, OPTICAL KSS-240A	
M102	X-4917-504-1	MOTOR ASSY (SPINDLE)	

<p>Note: The components identified by mark  or dotted line with mark  are critical for safety. Replace only with part number specified.</p>	<p>Note: Les composants identifiés par une marque  sont critiques pour la sécurité. Ne les remplacer que par une pièce portant le numéro spécifié.</p>
--	--

SECTION 7 ELECTRICAL PARTS LIST

BD

NOTE:

- Due to standardization, replacements in the parts list may be different from the parts specified in the diagrams or the components used on the set.
- -XX and -X mean standardized parts, so they may have some difference from the original one.
- RESISTORS
All resistors are in ohms.
METAL: Metal-film resistor.
METAL OXIDE: Metal oxide-film resistor.
F: nonflammable

- Items marked "*" are not stocked since they are seldom required for routine service. Some delay should be anticipated when ordering these items.
- SEMICONDUCTORS
In each case, u: μ , for example:
uA ..: μ A. uPA..: μ PA.
uPB..: μ PB. uPC..: μ PC. uPD..: μ PD.
- CAPACITORS
uF: μ F
- COILS
uH: μ H

The components identified by mark Δ or dotted line with mark Δ are critical for safety. Replace only with part number specified.

Les composants identifiés par une marque Δ sont critiques pour la sécurité. Ne les remplacer que par une pièce portant le numéro spécifié.

When indicating parts by reference number, please include the board.

- Abbreviation
AUS: Australian
EA: Saudi Arabia
G: Germany

Ref. No.	Part No.	Description	Remark
*	A-4617-977-A	BD BOARD, COMPLETE *****	
		< CAPACITOR >	
C101	1-163-005-11	CERAMIC CHIP 470PF	10% 50V
C102	1-163-038-00	CERAMIC CHIP 0.1uF	25V
C103	1-163-005-11	CERAMIC CHIP 470PF	10% 50V
C104	1-164-505-11	CERAMIC CHIP 2.2uF	16V
C105	1-135-155-21	TANTALUM CHIP 4.7uF	10% 16V
C106	1-164-346-11	CERAMIC CHIP 1uF	16V
C107	1-164-505-11	CERAMIC CHIP 2.2uF	16V
C108	1-164-346-11	CERAMIC CHIP 1uF	16V
C112	1-163-038-00	CERAMIC CHIP 0.1uF	25V
C151	1-163-007-11	CERAMIC CHIP 680PF	10% 50V
C152	1-163-007-11	CERAMIC CHIP 680PF	10% 50V
C153	1-163-038-00	CERAMIC CHIP 0.1uF	25V
C154	1-164-336-11	CERAMIC CHIP 0.33uF	25V
C155	1-163-007-11	CERAMIC CHIP 680PF	10% 50V
C156	1-163-007-11	CERAMIC CHIP 680PF	10% 50V
C157	1-163-037-11	CERAMIC CHIP 0.022uF	10% 25V
C158	1-163-037-11	CERAMIC CHIP 0.022uF	10% 25V
C159	1-163-023-00	CERAMIC CHIP 0.015uF	5% 50V
C160	1-163-019-00	CERAMIC CHIP 0.0068uF	10% 50V
C181	1-163-038-00	CERAMIC CHIP 0.1uF	25V
		< CONNECTOR >	
CN101	1-568-796-11	SOCKET, CONNECTOR 22P	
CN102	1-568-795-11	SOCKET, CONNECTOR 12P	
CN103	1-564-721-11	PIN, CONNECTOR (SMALL TYPE) 5P	
		< IC >	
IC101	8-752-344-48	IC CXD2501Q	
IC102	8-759-071-80	IC BA6297AFP	
IC103	8-759-040-83	IC BA6287F	

Ref. No.	Part No.	Description	Remark
		< RESISTOR >	
R101	1-216-077-00	METAL CHIP 15K 5%	1/10W
R102	1-216-097-00	METAL CHIP 100K 5%	1/10W
R103	1-216-077-00	METAL CHIP 15K 5%	1/10W
R104	1-216-085-00	METAL CHIP 33K 5%	1/10W
R105	1-216-097-00	METAL CHIP 100K 5%	1/10W
R112	1-216-049-00	METAL CHIP 1K 5%	1/10W
R113	1-216-077-00	METAL CHIP 15K 5%	1/10W
R114	1-216-077-00	METAL CHIP 15K 5%	1/10W
R117	1-216-077-00	METAL CHIP 15K 5%	1/10W
R118	1-216-077-00	METAL CHIP 15K 5%	1/10W
R121	1-216-077-00	METAL CHIP 15K 5%	1/10W
R122	1-216-077-00	METAL CHIP 15K 5%	1/10W
R151	1-216-070-00	METAL CHIP 7.5K 5%	1/10W
R152	1-216-070-00	METAL CHIP 7.5K 5%	1/10W
R153	1-216-070-00	METAL CHIP 7.5K 5%	1/10W
R154	1-216-070-00	METAL CHIP 7.5K 5%	1/10W
R155	1-216-070-00	METAL CHIP 7.5K 5%	1/10W
R156	1-216-070-00	METAL CHIP 7.5K 5%	1/10W
R157	1-216-085-00	METAL CHIP 33K 5%	1/10W
R158	1-216-076-00	METAL CHIP 13K 5%	1/10W
R159	1-216-085-00	METAL CHIP 33K 5%	1/10W
R160	1-216-081-00	METAL CHIP 22K 5%	1/10W
R161	1-216-093-00	METAL CHIP 68K 5%	1/10W
R162	1-216-085-00	METAL CHIP 33K 5%	1/10W
R163	1-216-308-00	METAL CHIP 4.7 5%	1/10W
R181	1-216-021-00	METAL CHIP 68 5%	1/10W
R182	1-216-021-00	METAL CHIP 68 5%	1/10W
		< SWITCH >	
S101	1-572-085-11	SWITCH, LEAF (LIM)	

HEADPHONE	LOADING	MAIN
------------------	----------------	-------------

Ref. No.	Part No.	Description		Remark
*	1-643-339-11	HEADPHONE BOARD *****		
		< CAPACITOR >		
C275	1-162-291-31	CERAMIC 560PF	10%	50V
C276	1-162-291-31	CERAMIC 560PF	10%	50V
C277	1-164-159-11	CERAMIC 0.1uF		50V
		< CONNECTOR >		
* CN271	1-568-941-11	PIN, CONNECTOR 3P		
		< JACK >		
J271	1-568-519-41	JACK, LARGE TYPE (PHONES)		
		< COIL >		
L271	1-412-473-21	INDUCTOR 0uH		
L272	1-412-473-21	INDUCTOR 0uH		
L273	1-412-473-21	INDUCTOR 0uH		

*	1-632-202-11	LOADING BOARD *****		
		< CONNECTOR >		
* CN301	1-564-707-11	PIN, CONNECTOR (SMALL TYPE) 5P		
		< SWITCH >		
S271	1-572-086-11	SWITCH, LEAF (OUT)		
S272	1-572-086-11	SWITCH, LEAF (IN)		

*	A-4649-369-A	MAIN BOARD, COMPLETE *****		
	1-694-001-11	JUMPER, FILM (WITH TERMINAL)		
		< CAPACITOR >		
C201	1-163-038-00	CERAMIC CHIP 0.1uF		25V
C202	1-124-261-00	ELECT 10uF	20%	50V
C210	1-163-038-00	CERAMIC CHIP 0.1uF		25V
C211	1-163-038-00	CERAMIC CHIP 0.1uF		25V
C212	1-163-038-00	CERAMIC CHIP 0.1uF		25V

Ref. No.	Part No.	Description		Remark
C264	1-124-584-00	ELECT	100uF	20% 10V
C265	1-124-584-00	ELECT	100uF	20% 10V
C266	1-126-157-11	ELECT	10uF	20% 16V
C270	1-163-038-00	CERAMIC CHIP	0.1uF	25V
C271	1-163-038-00	CERAMIC CHIP	0.1uF	25V
C272	1-163-038-00	CERAMIC CHIP	0.1uF	25V
C287	1-124-589-11	ELECT	47uF	20% 16V
C288	1-124-589-11	ELECT	47uF	20% 16V
C291	1-126-096-11	ELECT	10uF	20% 35V
C292	1-126-157-11	ELECT	10uF	20% 16V
C293	1-124-584-00	ELECT	100uF	20% 10V
C294	1-126-160-11	ELECT	1uF	20% 50V
C295	1-126-096-11	ELECT	10uF	20% 35V
C296	1-126-096-11	ELECT	10uF	20% 35V
C297	1-124-589-11	ELECT	47uF	20% 16V
C298	1-163-275-11	CERAMIC CHIP	0.001uF	5% 50V
C308	1-163-038-00	CERAMIC CHIP	0.1uF	25V
C311	1-163-809-11	CERAMIC CHIP	0.047uF	10% 25V
C312	1-163-011-11	CERAMIC CHIP	0.0015uF	10% 50V
C314	1-163-031-11	CERAMIC CHIP	0.01uF	50V
C315	1-164-005-11	CERAMIC CHIP	0.47uF	25V
C319	1-163-251-11	CERAMIC CHIP	100PF	5% 50V
C320	1-163-031-11	CERAMIC CHIP	0.01uF	50V
C321	1-163-102-00	CERAMIC CHIP	24PF	5% 50V
C325	1-163-233-00	CERAMIC CHIP	18PF	50V
C326	1-163-233-00	CERAMIC CHIP	18PF	50V
C327	1-163-038-00	CERAMIC CHIP	0.1uF	25V
C329	1-124-584-00	ELECT	100uF	20% 10V
C330	1-124-584-00	ELECT	100uF	20% 10V
C332	1-163-038-00	CERAMIC CHIP	0.1uF	25V
C333	1-163-038-00	CERAMIC CHIP	0.1uF	25V
C351	1-163-038-00	CERAMIC CHIP	0.1uF	25V
C352	1-163-038-00	CERAMIC CHIP	0.1uF	25V
C353	1-163-038-00	CERAMIC CHIP	0.1uF	25V
C355	1-163-038-00	CERAMIC CHIP	0.1uF	25V
C356	1-163-038-00	CERAMIC CHIP	0.1uF	25V
C361	1-163-253-11	CERAMIC CHIP	120PF	5% 50V
C362	1-163-253-11	CERAMIC CHIP	120PF	5% 50V
C363	1-163-241-11	CERAMIC CHIP	39PF	5% 50V
C364	1-163-241-11	CERAMIC CHIP	39PF	5% 50V
C365	1-163-241-11	CERAMIC CHIP	39PF	5% 50V
C366	1-163-241-11	CERAMIC CHIP	39PF	5% 50V
C367	1-163-038-00	CERAMIC CHIP	0.1uF	25V
C368	1-163-038-00	CERAMIC CHIP	0.1uF	25V
C371	1-163-017-00	CERAMIC CHIP	0.0047uF	5% 50V
C372	1-163-017-00	CERAMIC CHIP	0.0047uF	5% 50V
C373	1-163-143-00	CERAMIC CHIP	0.0012uF	5% 50V
C374	1-163-143-00	CERAMIC CHIP	0.0012uF	5% 50V

MAIN

Ref. No.	Part No.	Description	Remark
< DIODE >			
D201	8-719-106-18	DIODE RD6. 8M-B3	
D202	8-719-941-86	DIODE DAN202U	
D212	8-719-977-24	DIODE DT29. 1B	
D221	8-719-988-62	DIODE 1SS355	
D222	8-719-988-62	DIODE 1SS355	
D223	8-719-988-62	DIODE 1SS355	
D224	8-719-988-62	DIODE 1SS355	
D261	8-719-941-86	DIODE DAN202U	
D292	8-719-800-76	DIODE 1SS226	
D328	8-719-988-62	DIODE 1SS355	
< FLUORECENT INDICATOR >			
FLD201	1-519-611-11	INDICATOR TUBE, FLUORESCENT	
< IC >			
IC201	8-759-060-39	IC uPD75216AGF-661-3BE	
IC202	8-749-920-83	IC GP1U52XB	
IC203	8-759-633-42	IC M5293L	
IC271	8-759-981-86	IC RC4556M-A	
IC291	8-759-821-93	IC LA5601	
IC301	8-752-337-26	IC CXD2500AQ	
IC302	8-752-342-65	IC CXD256QM	
IC303	8-752-351-21	IC CXD2561BM	
IC306	8-759-981-92	IC RC4558M	
IC307	8-759-981-92	IC RC4558M	
< COIL >			
L291	1-410-658-31	INDUCTOR CHIP 220uH	
L292	1-410-658-31	INDUCTOR CHIP 220uH	
L321	1-410-375-11	INDUCTOR CHIP 3. 3uH	
L331	1-410-375-11	INDUCTOR CHIP 3. 3uH	
L351	1-410-375-11	INDUCTOR CHIP 3. 3uH	
L352	1-410-375-11	INDUCTOR CHIP 3. 3uH	
< TRANSISTOR >			
Q201	8-729-820-76	TRANSISTOR 2SA1179-M5M6	
Q261	8-729-805-45	TRANSISTOR 2SC3395	
Q271	8-729-141-75	TRANSISTOR 2SD596DV345	
Q272	8-729-141-75	TRANSISTOR 2SD596DV345	
Q273	8-729-805-69	TRANSISTOR 2SA1341	
Q281	8-729-141-75	TRANSISTOR 2SD596DV345	
Q282	8-729-141-75	TRANSISTOR 2SD596DV345	
< RESISTOR >			
R202	1-216-065-00	METAL CHIP 4. 7K 5%	1/10W
R203	1-216-065-00	METAL CHIP 4. 7K 5%	1/10W
R204	1-216-079-00	METAL CHIP 18K 5%	1/10W
R205	1-216-079-00	METAL CHIP 18K 5%	1/10W

Ref. No.	Part No.	Description	Remark
R206	1-216-079-00	METAL CHIP 18K 5%	1/10W
R207	1-216-065-00	METAL CHIP 4. 7K 5%	1/10W
R208	1-216-097-00	METAL CHIP 100K 5%	1/10W
R209	1-216-097-00	METAL CHIP 100K 5%	1/10W
R215	1-216-073-00	METAL CHIP 10K 5%	1/10W
R218	1-216-093-00	METAL CHIP 68K 5%	1/10W
R221	1-216-079-00	METAL CHIP 18K 5%	1/10W
R222	1-216-079-00	METAL CHIP 18K 5%	1/10W
R223	1-216-079-00	METAL CHIP 18K 5%	1/10W
R224	1-216-079-00	METAL CHIP 18K 5%	1/10W
R225	1-216-079-00	METAL CHIP 18K 5%	1/10W
R226	1-216-079-00	METAL CHIP 18K 5%	1/10W
R235	1-216-079-00	METAL CHIP 18K 5%	1/10W
R236	1-216-079-00	METAL CHIP 18K 5%	1/10W
R237	1-216-079-00	METAL CHIP 18K 5%	1/10W
R267	1-216-097-00	METAL CHIP 100K 5%	1/10W
R268	1-216-097-00	METAL CHIP 100K 5%	1/10W
R271	1-216-019-00	METAL CHIP 56 5%	1/10W
R272	1-216-019-00	METAL CHIP 56 5%	1/10W
R273	1-216-053-00	METAL CHIP 1. 5K 5%	1/10W
R274	1-216-053-00	METAL CHIP 1. 5K 5%	1/10W
R275	1-216-097-00	METAL CHIP 100K 5%	1/10W
R285	1-216-049-00	METAL CHIP 1K 5%	1/10W
R286	1-216-049-00	METAL CHIP 1K 5%	1/10W
R287	1-216-025-00	METAL CHIP 100 5%	1/10W
R288	1-216-025-00	METAL CHIP 100 5%	1/10W
R289	1-216-053-00	METAL CHIP 1. 5K 5%	1/10W
R290	1-216-053-00	METAL CHIP 1. 5K 5%	1/10W
R291	1-216-298-00	METAL CHIP 2. 2 5%	1/10W
R293	1-216-025-00	METAL CHIP 100 5%	1/10W
R309	1-216-025-00	METAL CHIP 100 5%	1/10W
R311	1-216-061-00	METAL CHIP 3. 3K 5%	1/10W
R312	1-216-073-00	METAL CHIP 10K 5%	1/10W
R313	1-216-061-00	METAL CHIP 3. 3K 5%	1/10W
R315	1-216-037-00	METAL CHIP 330 5%	1/10W
R316	1-216-049-00	METAL CHIP 1K 5%	1/10W
R317	1-216-053-00	METAL CHIP 1. 5K 5%	1/10W
R318	1-216-097-00	METAL CHIP 100K 5%	1/10W
R319	1-216-121-00	METAL CHIP 1M 5%	1/10W
R320	1-216-049-00	METAL CHIP 1K 5%	1/10W
R321	1-216-049-00	METAL CHIP 1K 5%	1/10W
R322	1-216-049-00	METAL CHIP 1K 5%	1/10W
R323	1-216-049-00	METAL CHIP 1K 5%	1/10W
R324	1-216-049-00	METAL CHIP 1K 5%	1/10W
R325	1-216-049-00	METAL CHIP 1K 5%	1/10W
R326	1-216-049-00	METAL CHIP 1K 5%	1/10W
R327	1-216-121-00	METAL CHIP 1M 5%	1/10W
R328	1-216-073-00	METAL CHIP 10K 5%	1/10W
R331	1-216-041-00	METAL CHIP 470 5%	1/10W

MAIN POWER

Ref. No.	Part No.	Description	Remark		
R334	1-216-057-00	METAL CHIP	2.2K	5%	1/10W
R343	1-216-057-00	METAL CHIP	2.2K	5%	1/10W
R351	1-216-748-11	METAL CHIP	39K	1%	1/10W
R352	1-216-748-11	METAL CHIP	39K	1%	1/10W
R353	1-216-748-11	METAL CHIP	39K	1%	1/10W
R354	1-216-748-11	METAL CHIP	39K	1%	1/10W
R355	1-216-748-11	METAL CHIP	39K	1%	1/10W
R356	1-216-748-11	METAL CHIP	39K	1%	1/10W
R357	1-216-748-11	METAL CHIP	39K	1%	1/10W
R358	1-216-748-11	METAL CHIP	39K	1%	1/10W
R361	1-216-079-00	METAL CHIP	18K	5%	1/10W
R362	1-216-079-00	METAL CHIP	18K	5%	1/10W
R363	1-216-079-00	METAL CHIP	18K	5%	1/10W
R364	1-216-079-00	METAL CHIP	18K	5%	1/10W
R365	1-216-091-00	METAL CHIP	56K	5%	1/10W
R366	1-216-091-00	METAL CHIP	56K	5%	1/10W
R367	1-216-091-00	METAL CHIP	56K	5%	1/10W
R368	1-216-091-00	METAL CHIP	56K	5%	1/10W
R369	1-216-053-00	METAL CHIP	1.5K	5%	1/10W
R370	1-216-053-00	METAL CHIP	1.5K	5%	1/10W
R371	1-216-053-00	METAL CHIP	1.5K	5%	1/10W
R372	1-216-053-00	METAL CHIP	1.5K	5%	1/10W
R395	1-216-066-00	METAL CHIP	5.1K	5%	1/10W
R396	1-216-066-00	METAL CHIP	5.1K	5%	1/10W
R397	1-216-066-00	METAL CHIP	5.1K	5%	1/10W
R398	1-216-066-00	METAL CHIP	5.1K	5%	1/10W
< VARIABLE RESISTOR >					
RV271	1-238-748-11	RES, VAR, CARBON 1K/1K (PHONE LEVEL)			
< SWITCH >					
S201	1-554-303-21	SWITCH, TACTILE (OPEN/CLOSE)			
S202	1-554-303-21	SWITCH, TACTILE (CONTINUE)			
S203	1-554-303-21	SWITCH, TACTILE (SHUFFLE)			
S204	1-554-303-21	SWITCH, TACTILE (PROGRAM)			
S205	1-554-303-21	SWITCH, TACTILE (FADER)			
S206	1-554-303-21	SWITCH, TACTILE (REPEAT)			
S207	1-554-303-21	SWITCH, TACTILE (TIME)			
S208	1-554-303-21	SWITCH, TACTILE (CLEAR)			
S209	1-554-303-21	SWITCH, TACTILE (CHECK)			
S210	1-554-303-21	SWITCH, TACTILE (PEAK SEARCH)			
S211	1-554-303-21	SWITCH, TACTILE (K<< >>)			
S212	1-554-303-21	SWITCH, TACTILE (> /)			
S213	1-554-303-21	SWITCH, TACTILE (>> >>)			
S214	1-554-303-21	SWITCH, TACTILE (EDIT/TIME FADE)			
S215	1-554-303-21	SWITCH, TACTILE (□)			
S216	1-554-303-21	SWITCH, TACTILE (MUSIC SCAN)			

Ref. No.	Part No.	Description	Remark		
< VIBRATOR >					
X201	1-577-358-21	VIBRATOR, CERAMIC (4MHz)			
X327	1-579-314-11	VIBRATOR, CRYSTAL (22.5792MHz)			

*	1-643-338-11	POWER BOARD			

< CAPACITOR >					
C281	1-162-291-31	CERAMIC	560PF	10%	50V
C282	1-162-291-31	CERAMIC	560PF	10%	50V
C901	1-124-898-11	ELECT	4700uF	20%	16V (US, Canadian)
C901	1-126-017-11	ELECT	6800uF	20%	16V (EXCEPT US, Canadian)
C902	1-126-939-11	ELECT	10000uF	20%	16V
C903	1-124-572-11	ELECT	100uF	20%	63V
C904	1-164-159-11	CERAMIC	0.1uF		50V
C905	1-164-159-11	CERAMIC	0.1uF		50V
C906	1-164-159-11	CERAMIC	0.1uF		50V
C907	1-164-159-11	CERAMIC	0.1uF		50V
C908	1-164-159-11	CERAMIC	0.1uF		50V
< CONNECTOR >					
CN281	1-506-469-11	CONNECTOR 4P, MALE			
* CN901	1-568-951-11	PIN, CONNECTOR 2P			
CN902	1-506-468-11	CONNECTOR 3P, MALE			
△CN903	1-580-230-11	PIN, CONNECTOR (PC BOARD) 3P			
< DIODE >					
D901	8-719-200-82	DIODE	11ES2		
D902	8-719-200-82	DIODE	11ES2		
D903	8-719-200-82	DIODE	11ES2		
D904	8-719-200-82	DIODE	11ES2		
D905	8-719-200-82	DIODE	11ES2		
< JACK >					
J281	1-569-442-11	JACK, PIN 2P (LINE OUT)			
J901	1-412-473-21	INDUCTOR	0uH		
J902	1-412-473-21	INDUCTOR	0uH		
J903	1-412-473-21	INDUCTOR	0uH		
< SWITCH >					
S901	1-571-722-11	SWITCH, VOLTAGE SELECTION (E)			

<p>The components identified by mark △ or dotted line with mark △ are critical for safety. Replace only with part number specified.</p>	<p>Les composants identifiés par une marque △ sont critiques pour la sécurité. Ne les remplacer que par une pièce portant le numéro spécifié.</p>
---	---

POWEVR

Ref. No.	Part No.	Description	Remark
< TRANSFORMER >			
△T901	1-450-212-11	TRANSFORMER, POWER (297:US, Canadian, 397:US)	
△T901	1-450-213-11	TRANSFORMER, POWER (297:AEP, AUS, G/397:AEP, AUS, UK, G)	
△T901	1-450-214-11	TRANSFORMER, POWER (E, EA)	

*	1-643-340-11	POWER SW BOARD *****	
< CONNECTOR >			
CN291	1-506-469-11	CONNECTOR 4P, MALE	
< SWITCH >			
S291	1-554-118-00	SWITCH, PUSH (1 KEY)	

MISCELLANEOUS *****			
△8	1-569-007-11	ADAPTER, CONVERSION 2P (297:E2/E3)	
△9	1-569-008-11	ADAPTER, CONVERSION 2P (297:EA3)	
△18	1-558-946-21	CORD, POWER (UK)	
△18	1-558-943-41	CORD, POWER (E)	
△18	1-574-358-31	CORD, POWER (WITH CONNECTOR) (AUS)	
△18	1-575-651-21	CORD, POWER (G)	
△18	1-575-651-21	CORD, POWER (397:AEP/297:AEP, EA)	
△18	1-590-836-11	CORD, POWER (297:US, Canadian/397:US)	
* 311	1-452-538-11	MAGNET	
354	1-575-001-11	WIRE, FLAT TYPE (12 CORE)	
△357	8-848-144-11	DEVICE, OPTICAL KSS-240A	
M102	X-4917-504-1	MOTOR ASSY (SPINDLE)	
M191	A-4604-363-A	MOTOR (L) ASSY	
△T901	1-450-212-11	TRANSFORMER, POWER (297:US, Canadian/397:US)	
△T901	1-450-213-11	TRANSFORMER, POWER (297:AEP, AUS, G/397:AEP, AUS, UK, G)	
△T901	1-450-214-11	TRANSFORMER, POWER (E, EA)	

Ref. No.	Part No.	Description	Remark
ACCESSORIES & PACKING MATERIALS *****			
	1-465-635-11	REMOTE COMMANDER (RM-D295) (397)	
	1-558-271-11	CORD, CONNECTION	
	2-181-754-01	COVER, BATTERY (397:AEP, AUS, US)	
	3-754-502-11	MANUAL, INSTRUCTION (ENGLISH, FRENCH, SPANISH, PORTUGUESE) (297:AEP, Canadian, AUS, E, EA/397:AEP, AUS)	
	3-754-502-21	MANUAL, INSTRUCTION (ENGLISH) (US)	
	3-754-502-41	MANUAL, INSTRUCTION (GERMAN, DUCH, SWEDISH) (AEP)	
	3-754-502-51	MANUAL, INSTRUCTION (ENGLISH, FRENCH, SPANISH, PORTUGUESE) (UK)	
	3-754-502-81	MANUAL, INSTRUCTION (D) (G)	
*	4-925-389-01	CUSHION	
*	4-941-548-01	LABEL, CLASS 1 (EXCEPT US, Canadian)	

HARDWARE LIST

#1	7-621-255-15	SCREW +P 2X3
#2	7-621-775-10	SCREW +B 2.6X4
#3	7-682-547-04	SCREW +BVTT 3X6 (S)
#4	7-682-548-09	SCREW +BVTT 3X8 (S)
#5	7-682-562-09	SCREW +BVTT 4X10 (S)
#6	7-685-134-19	SCREW +BTP 2.6X8 TYPE2 N-S
#7	7-685-646-79	SCREW +BVTP 3X8 TYPE2 N-S

<p>The components identified by mark △ or dotted line with mark. △ are critical for safety. Replace only with part number specified.</p>	<p>Les composants identifiés par une marque △ sont critiques pour la sécurité. Ne les remplacer que par une pièce portant le numéro spécifié.</p>
--	---

CDP-297/397

SONY[®] SERVICE MANUAL

*US Model
Canadian Model
AEP Model
E Model
Australian Model
CDP-297*

SUPPLEMENT-1

File this supplement with the service manual.

*US Model
Canadian Model
AEP Model
UK Model
Australian Model
CDP-397*

Subject :

1. Canadian Model has been added for CDP-397.
As only the difference from US Model is described, please refer CDP-297/397 service manual for the other sections.
2. CORRECTION (PAGE 2)

Page	US MODEL		Canadian MODEL	
	<u>Ref. No.</u>	<u>Part No.</u>	<u>Part No.</u>	<u>Description</u>
24, 25	13	4-949-538-31	4-949-538-61	PANEL, BACK
32	ACCESSORY	3-754-502-21	3-754-502-11	MANUAL, INSTRUCTION (ENGLISH, FRENCH)

 : indicates corrected portion.

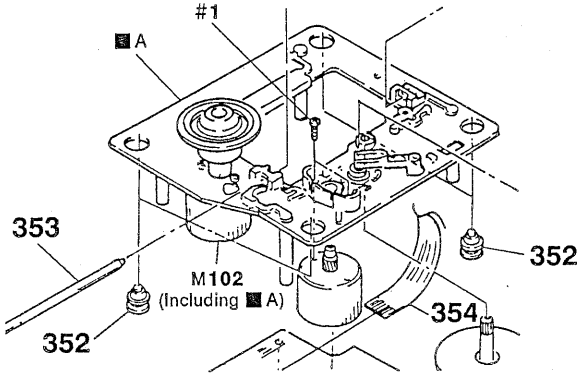
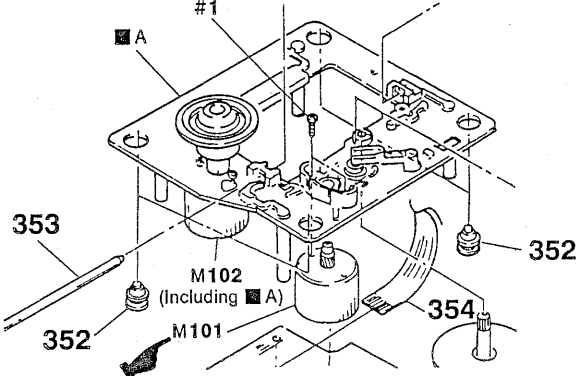
Page	INCORRECT	CORRECT																	
27																			
	<table border="1"> <thead> <tr> <th>Ref. No.</th> <th>Part No.</th> <th>Description</th> </tr> </thead> <tbody> <tr> <td>M102</td> <td>X-4917-504-1</td> <td>MOTOR ASSY (SPINDLE)</td> </tr> <tr> <td>—</td> <td>—</td> <td>—</td> </tr> </tbody> </table>	Ref. No.	Part No.	Description	M102	X-4917-504-1	MOTOR ASSY (SPINDLE)	—	—	—	<table border="1"> <thead> <tr> <th>Ref. No.</th> <th>Part No.</th> <th>Description</th> </tr> </thead> <tbody> <tr> <td>M101</td> <td>X-4917-504-1</td> <td>MOTOR ASSY (SLED)</td> </tr> <tr> <td>M102</td> <td>X-4917-523-3</td> <td>MOTOR ASSY (SPINDLE)</td> </tr> </tbody> </table>	Ref. No.	Part No.	Description	M101	X-4917-504-1	MOTOR ASSY (SLED)	M102	X-4917-523-3
Ref. No.	Part No.	Description																	
M102	X-4917-504-1	MOTOR ASSY (SPINDLE)																	
—	—	—																	
Ref. No.	Part No.	Description																	
M101	X-4917-504-1	MOTOR ASSY (SLED)																	
M102	X-4917-523-3	MOTOR ASSY (SPINDLE)																	