

CDP-302 / 302ES / 520ES

SERVICE MANUAL

Refer to RM-D302/D502 Service Manual issued separately for information of the remote controller supplied with this set.

CDP-302, CDP-520ES:

US Model

CDP-302:

Canadian Model

CDP-302ES:

AEP Model

UK Model

E Model

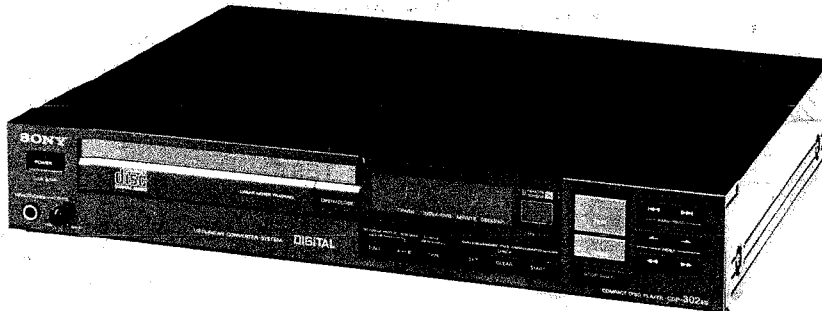

Photo: CDP-302ES

COMPACT
disc
DIGITAL AUDIO

SPECIFICATIONS

COMPACT DISC PLAYER

System	Compact disc digital audio system
Disc	Compact disc
Laser diode properties	Material: GaAlAs Wavelength: 780 nm Emission duration: Continuous Laser output: Max. 0.6 mW*

*This output is the value measured at a distance of about 1.6 mm from the objective lens surface on the optical pick-up block.

Spindle speed	500 r.p.m. to 200 r.p.m. (CLV)
Scan velocity	1.2 - 1.4 m/sec.
Error correction	Sony Super Strategy Cross Interleave Reed Solomon Code
Number of channels	2
D-A conversion	16-bit linear
Frequency response	2 - 20,000 Hz ± 0.5 dB
Harmonic distortion	Less than 0.003 % (1 kHz)
Dynamic range	More than 96 dB
Channel separation	More than 95 dB

SAFETY-RELATED COMPONENT WARNING!!

COMPONENTS IDENTIFIED BY SHADING AND MARK  ON THE SCHEMATIC DIAGRAMS AND IN THE PARTS LIST ARE CRITICAL TO SAFE OPERATION. REPLACE THESE COMPONENTS WITH SONY PARTS WHOSE PART NUMBERS APPEAR AS SHOWN IN THIS MANUAL OR IN SUPPLEMENTS PUBLISHED BY SONY.

Wow and flutter	Below measurable limit
Outputs	Line outputs Output level 2 V rms (at MSB) Load impedance over 10 kilohms Headphones 28 mW at 32 ohms Remote control connectors (4-pin)
Other jacks	
Disc	
Track pitch	1.6 μ m
Sampling frequency	44.1 kHz
Quantization	16 bit linear quantizing/channel
Modulation system	EFM
Transfer rate	2.03 Mbit/sec. (before modulation)
General	
Dimensions	Approx. 430 x 80 x 335 mm (w/h/d) (17 x 3 ¹ / ₄ x 13 ³ / ₄ in.) including projecting parts and controls
Weight	Approx. 6.7 kg (14 lb 13 oz), net

ATTENTION AU COMPOSANT AYANT RAPPORT À LA SÉCURITÉ!

LES COMPOSANTS IDENTIFIÉS PAR UNE TRAME ET UNE MARQUE  SUR LES DIAGRAMMES SCHÉMATIQUES ET LA LISTE DES PIÈCES SONT CRITIQUES POUR LA SÉCURITÉ DE FONCTIONNEMENT. NE REMPLACER CES COMPOSANTS QUE PAR DES PIÈCES SONY DONT LES NUMÉROS SONT DONNÉS DANS CE MANUEL OU DANS LES SUPPLÉMENTS PUBLIÉS PAR SONY.



COMPACT DISK PLAYER
SONY[®]

AUD

CDP-302/302ES/520ES

MODEL IDENTIFICATION

CDP-302

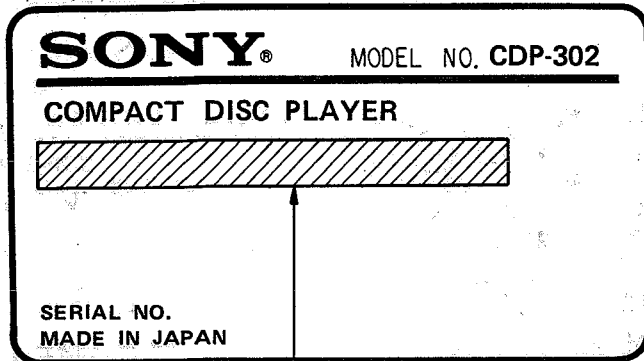

US model: AC: 120 V ~ 60 Hz 15 W
 Canadian model: AC: 120 V ~ 60 Hz 15 W

CDP-302ES

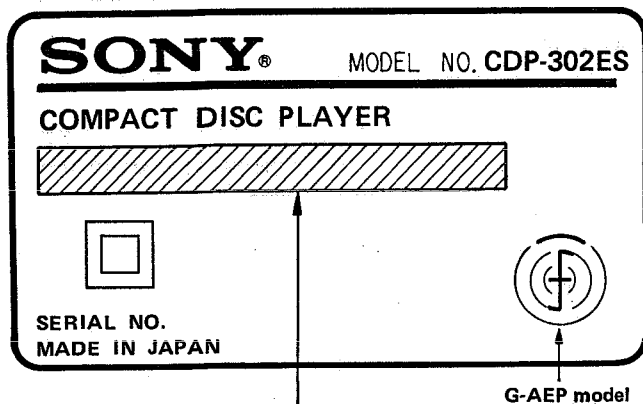

AEP model: AC: 220 V ~ 50/60 Hz 15 W
 G-AEP model: AC: 220 V ~ 50/60 Hz 15 W
 UK model: AC: 240 V ~ 50/60 Hz 15 W
 E model: AC: 110, 120, 220, 240 V ~ 50/60 Hz 15 W

CDP-520ES

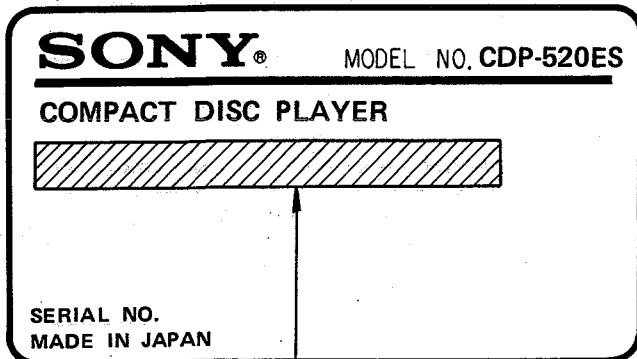

US model: AC: 120 V ~ 60 Hz 15 W

SAFETY CHECK-OUT (US Model)

After correcting the original service problem, perform the following safety check before releasing the set to the customer:

Check the antenna terminals, metal trim, "metallized" knobs, screws, and all other exposed metal parts for AC leakage. Check leakage as described below.

LEAKAGE TEST

The AC leakage from any exposed metal part to earth ground and from all exposed metal parts to any exposed metal part having a return to chassis, must not exceed 0.5 mA (500 microamperes). Leakage current can be measured by any one of three methods.

1. A commercial leakage tester, such as the Simpson 229 or RCA WT-540A. Follow the manufacturers' instructions to use these instruments.
2. A battery-operated AC milliammeter. The Data Precision 245 digital multimeter is suitable for this job.
3. Measuring the voltage drop across a resistor by means of a VOM or battery-operated AC voltmeter. The "limit" indication is 0.75 V, so analog meters must have an accurate low-voltage scale. The Simpson 250 and Sanwa SH-63Trd are examples of a passive VOM that is suitable. Nearly all battery operated digital multimeters that have a 2 V AC range are suitable. (See Fig. A)

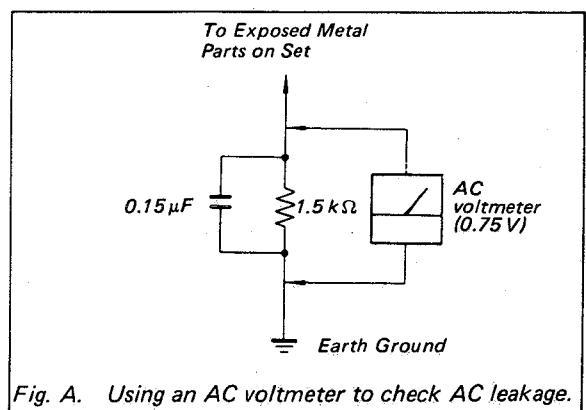

Fig. A. Using an AC voltmeter to check AC leakage.

PROTECTION OF EYES FROM LASER BEAM DURING SERVICING

This set employs a laser. Therefore, be sure to follow carefully the instructions below when servicing.

WARNING !!

WHEN SERVICING, DO NOT APPROACH THE LASER EXIT WITH THE EYE TOO CLOSELY. IN CASE IT IS NECESSARY TO CONFIRM LASER BEAM EMISSION, BE SURE TO OBSERVE FROM A DISTANCE OF MORE THAN 30 cm FROM THE SURFACE OF THE OBJECTIVE LENS ON THE OPTICAL PICK-UP BLOCK.

1. Laser Diode Properties

- Material: GaAlAs
- Wavelength: 780 nm
- Emission Duration: continuous
- Laser Output: max. 0.6 mW*

* This output is the value measured at a distance of about 1.6 mm from the objective lens surface on the Optical Pick-up Block.

- Classification: Class IIIb

2. During service, do not take the Optical Pick-up Block apart, and do not adjust the APC circuit. If there is a breakdown in the APC circuit (including laser diode), replace the entire Optical Pick-up Block (including APC board).

LASER WARNING LABELS

The labels shown below are affixed.

1. Protective Housing Label

DHHS Non-Interlocked Protective Housing Label
..... (US, Canadian model)

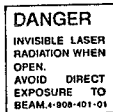

2. Interlock defeatable Label

..... (US, Canadian model)

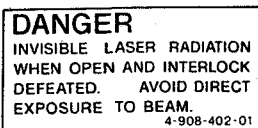

- US, Canadian model

2. Aperture Label..... (AEP, UK, E model)



- See figure on next page for location of label.

3. Caution Label..... (AEP, UK, E model)

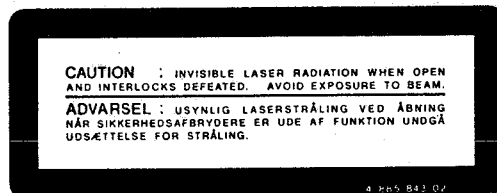

- AEP, UK, E model

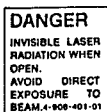
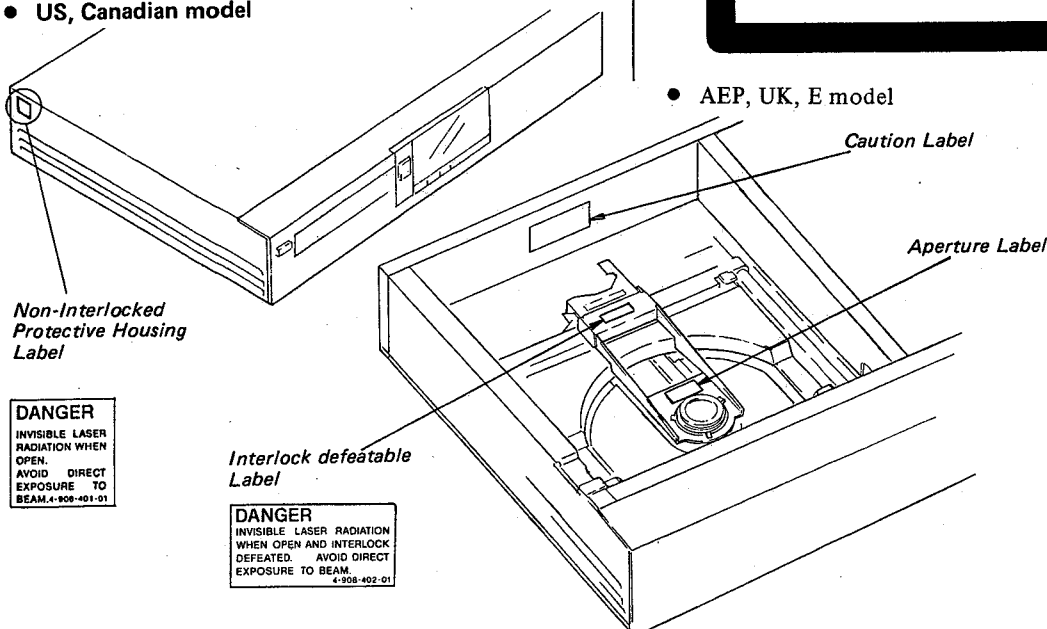

Interlock defeatable Label

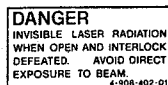

BESKYTTELSE AF ØJNE MOD LASERSTRÅLING UNDER SERVICE

I dette apparat anvendes laserlys. Derfor skal nedenstående instruktioner nøje følges under service.

Følg iverigt instruktionerne i servicemanualen.

ADVARSEL!!

Under service må øjnene ikke komme nær objektiv-linsen på den optiske pick-up enhed. I tilfælde af at det er nødvendigt at kontrollere udsendelsen af laserlys, skal det ske i en afstand af mere end 30 cm fra den optiske pick-up.

1. Data for Laser Diode

- Materiale: GaAlAs
- Bølgelængde: 780 nm
- Udstråling: Kontinuerlig
- Laser Output: max. 0.6 mW*
 - * målt i 1.6 mm afstand fra overfladen af objektiv-linsen på den optiske pick-up enhed.
- Klassifikation: Svarende til klasse IIIb

2. Adskil aldrig den optiske pick-up enhed under service, og juster ikke APC kredsløbet (Automatic Power Control). Hvis APC kredsløbet (incl. laser-dioden) bryder ned, skal hele den optiske pick-up enhed (incl. APC printkortet) udskiftes.

LASER ADVARSEL MÆRKNING (AEP model)

Følgende mærkning findes indvendig i apparatet:

1. Advarsel Mærkning

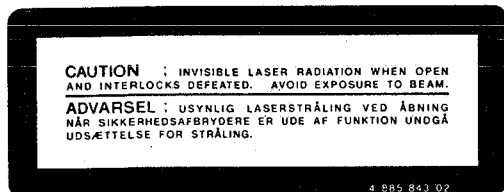

2. Aperture Label



- AEP, UK model

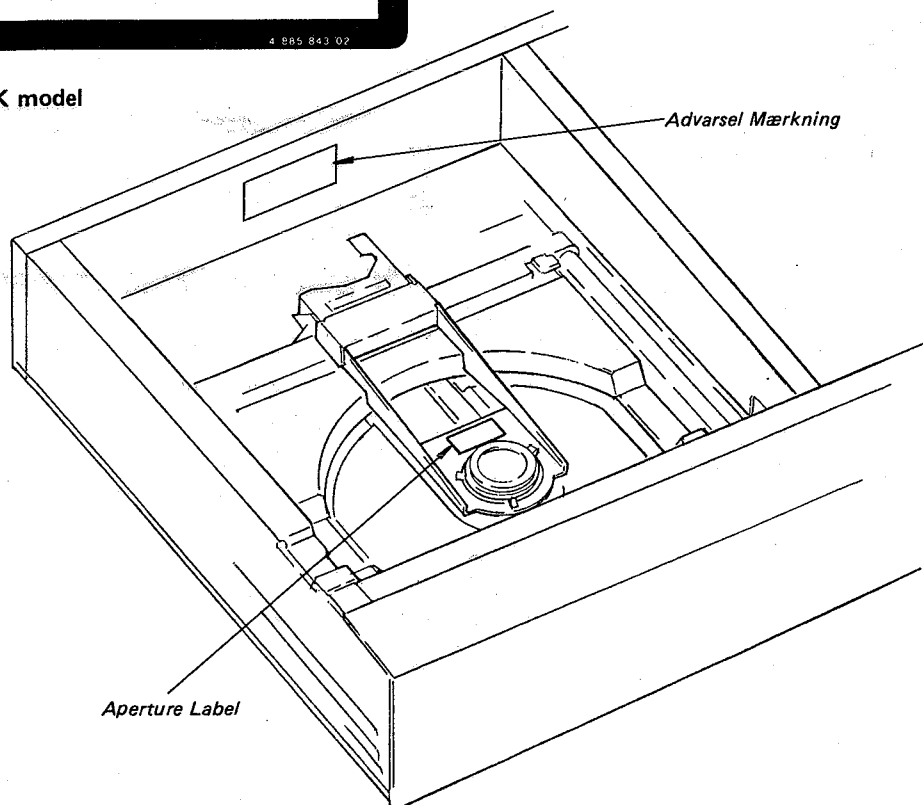

— CAUTION FOR ELECTROSTATIC BREAKDOWN —

NOTES ON HANDLING THE OPTICAL PICK-UP BLOCK (BU-1)

The laser diode in the optical pick-up block may suffer electrostatic breakdown because of the potential difference generated by the charged electrostatic load, etc. on clothing and the human body.

The printed matter below is included in the repair parts. During repair, use the procedure in the printed matter.

The following method is an example for reference purposes:

1. Place a conductive sheet on the workbench. (The black sheet used as repair parts wrapping).
2. Place the set on the conductive sheet so that the chassis touches the sheet. (This makes it the same potential as the conductive sheet).
3. Place your hands on the conductive sheet. (This makes them the same potential as the sheet).
4. Remove the optical pick-up block.
5. Perform work on top of the conductive sheet. Be careful that clothing does not touch the optical pick-up block.

Printed Matter Included in the Repair Parts

When opening or repairing a BU-1, the procedure for grounding as follows is required to prevent damage caused by static electricity.

1. Grounding for the human body.
Be sure to put on a wrist-strap for grounding (with impedance lower than $10^8 \Omega$) whose other end is grounded. The strap works to drain away the static electricity built-up on the human body.
2. Grounding for the work table.
Be sure to lay on the table a conductive sheet (with impedance lower than $10^9 \Omega$) such as sheet of copper which is grounded.
3. As static electricity built-up on clothes is not drained away, be careful not to let your clothes touch the BU-1.

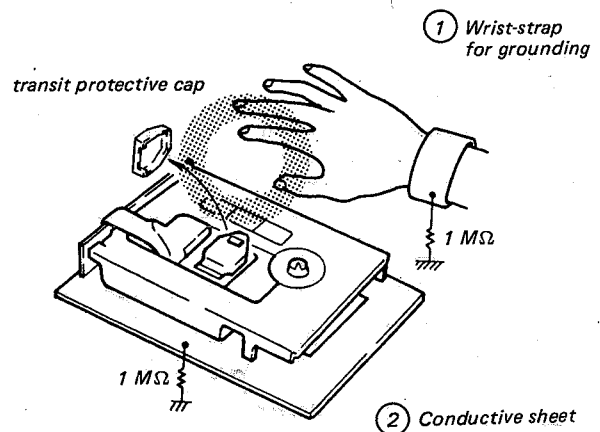
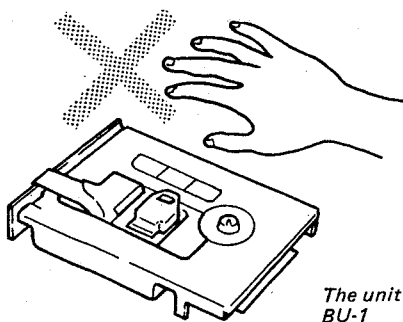

— SERVICING NOTE —

NOTES ON LASER DIODE EMISSION CHECK

The laser beam on this model is concentrated so as to be focused on the disc reflective surface by the objective lens in the optical pick-up block. Therefore, when checking the laser diode emission, observe, from more than 30 cm away from the objective lens.

LASER DIODE AND FOCUS SEARCH OPERATION CHECK

1. Make POWER switch on with no disc inserted and disc table closed.
2. Confirm that the following operation is performed while observing the objective lens.

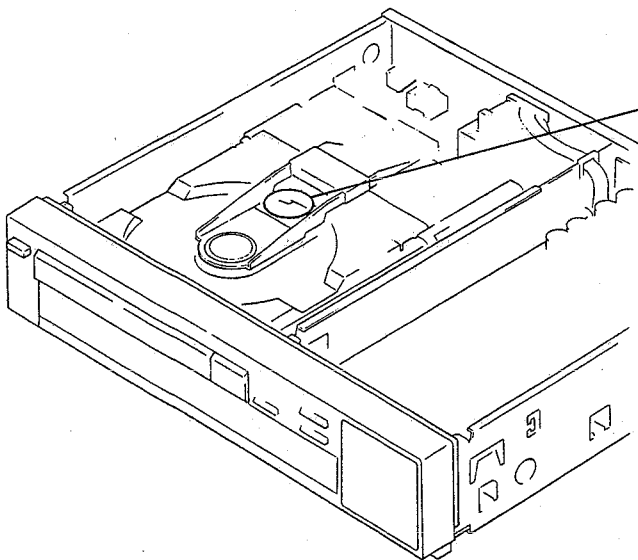
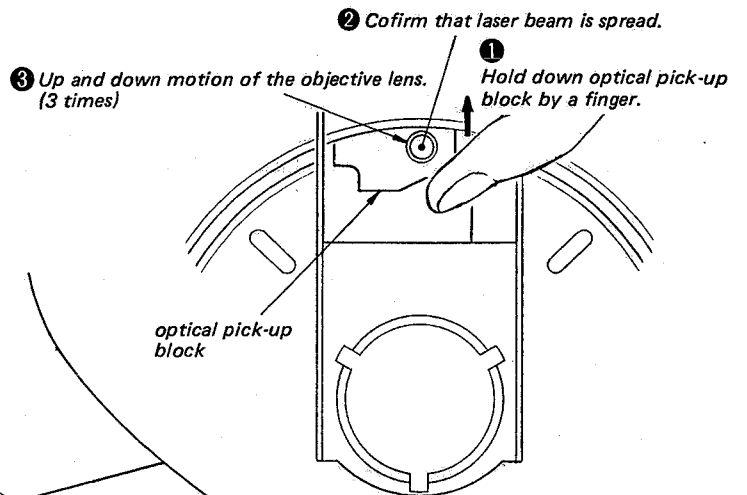

A transit lever is provided at the bottom of the unit to protect the optical system against shock during transportation. Before starting repairing, make following procedures.

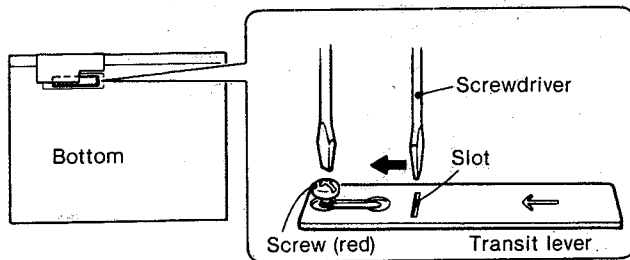

- 1 Loosen the screw (red) with the screwdriver.
- 2 Insert the screwdriver into the slot in the lever and move it in the direction of the arrow until it stops.
- 3 Tighten the screw.

**FLOW CHART OF BU-1 (BASE UNIT)
TROUBLE SHOOTING**

- Confirm all connectors around BU-1 (base unit) are secured before the following check.

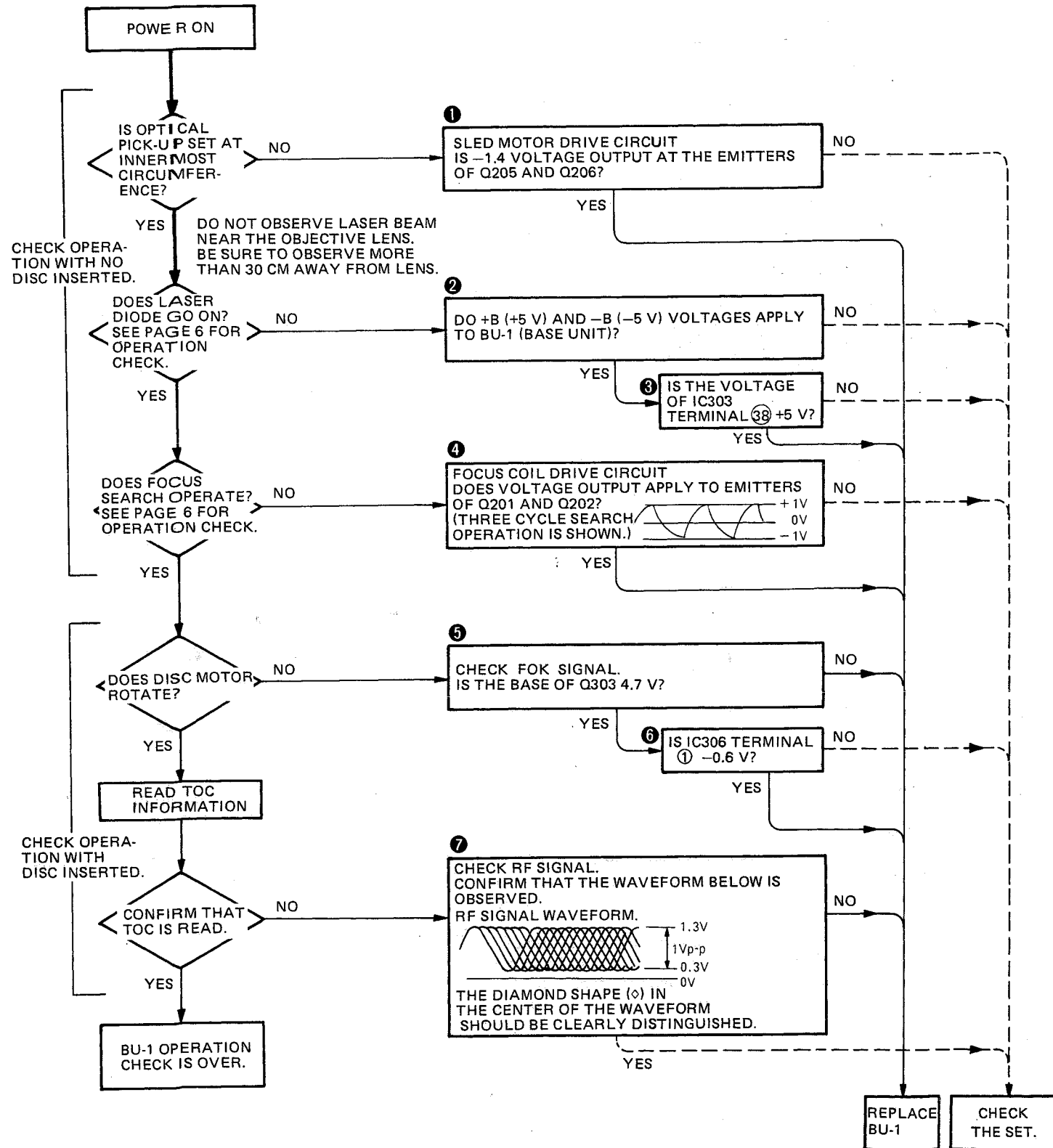

MAIN BOARD

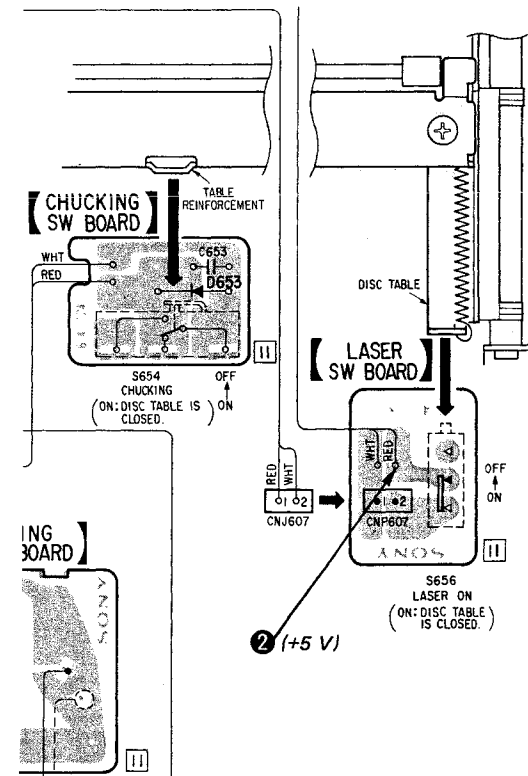
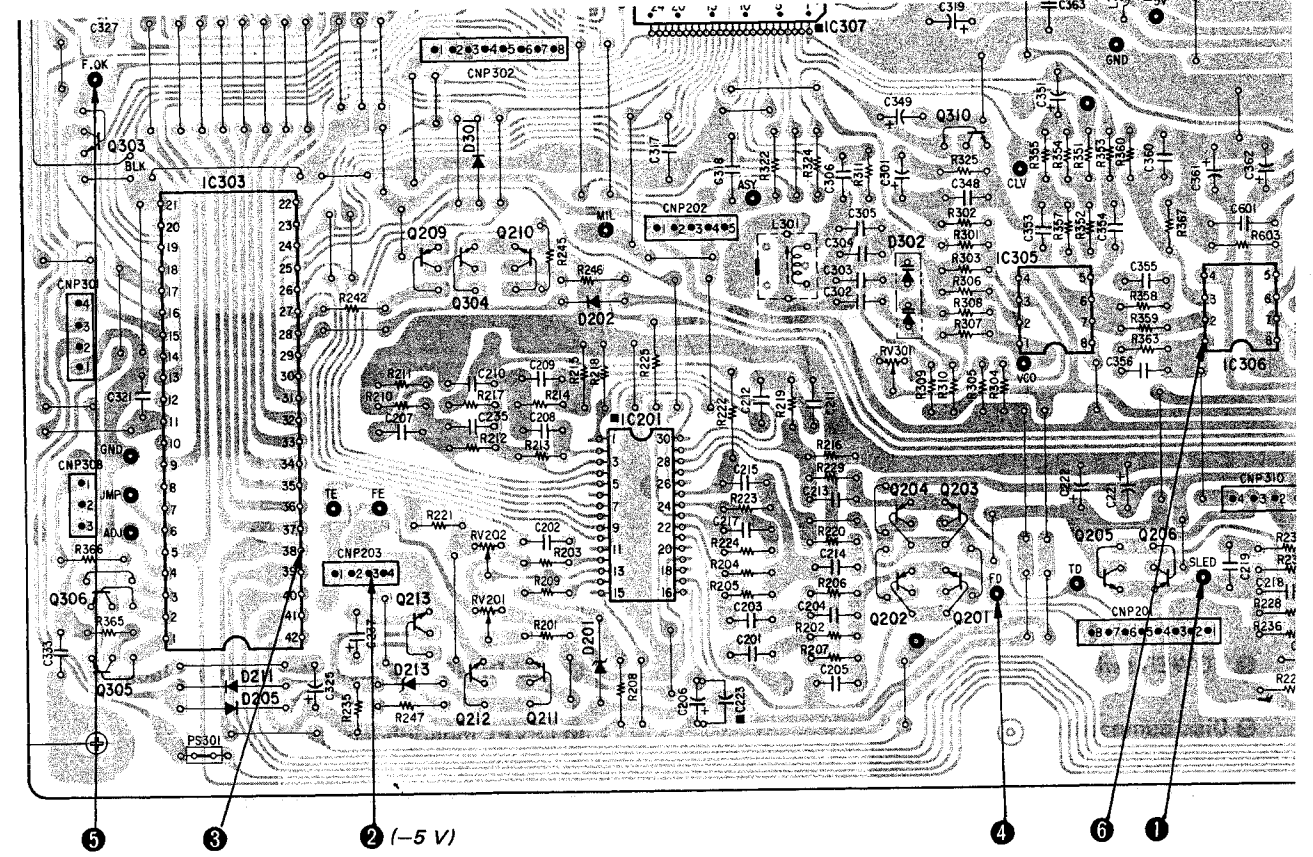

BU-1 (BASE UNIT)

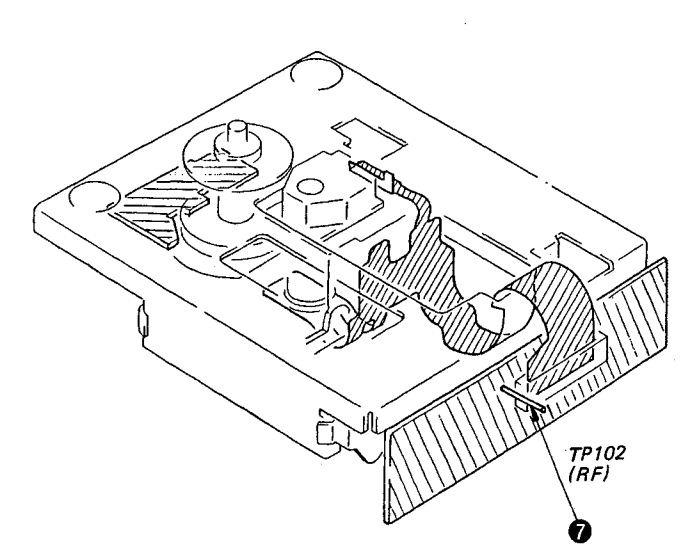

LOCATION AND FUNCTION OF CONTROLS

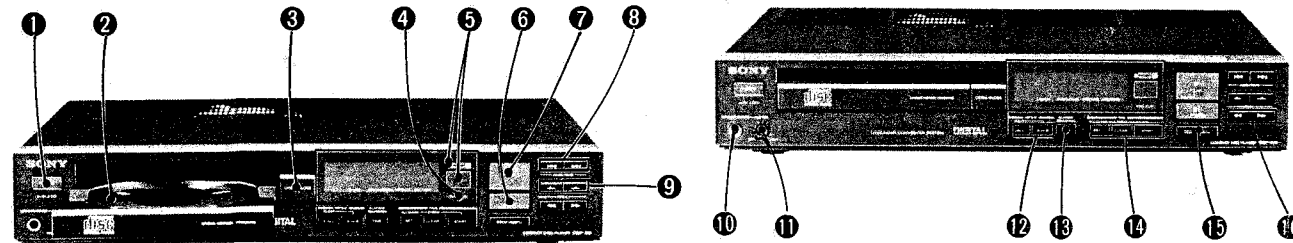

- 1 POWER switch
- 2 Disc compartment
- 3 OPEN/CLOSE button
- 4 RMS PLAY indicator
- 5 REMOTE SENSOR and indicator (for remote control)
- 6 || PAUSE button and indicator
- 7 ► PLAY button and indicator
- 8 AMS/RMS buttons
- 9 INDEX buttons

- 10 HEADPHONES jack (stereo phone jack)
- 11 LEVEL (headphones level) control
- 12 REPEAT programming buttons
- 13 ELAPSED/REMAINING TIME button
- 14 RMS buttons
- 15 STOP (RESET) button
- 16 Manual search buttons

Display window

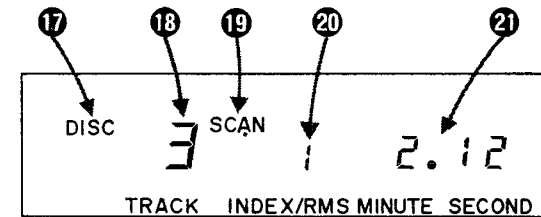

- 17 DISC indicator
- 18 TRACK indicator
- 19 SCAN indicator
- 20 INDEX/RMS indicator
- 21 Time counter

Rear panel

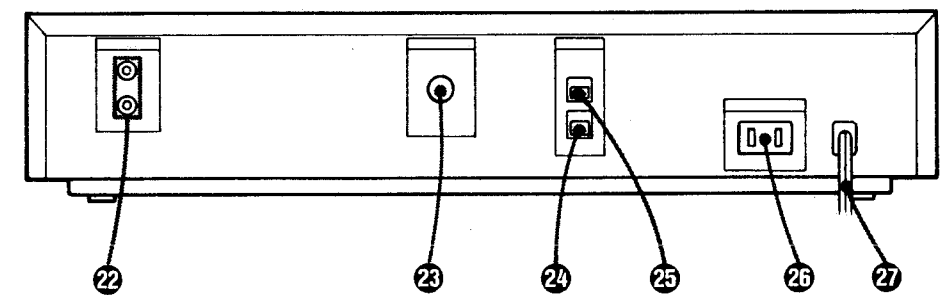

- 22 LINE OUT jacks
- 23 SUBCODE connector
This connector is provided to extend the utility of this compact disc player by allowing for the connection of optional equipment which will be available in the future.
- 24 **R** REMOTE OUT (remote control output) connector
Connect this connector to remote control input connector of optional Sony TC-W7R cassette deck, etc. For details, refer to the operating instructions of the RM-S410 system controller.
- 25 **R** REMOTE IN (remote control input) connector
Connect this connector to remote control output connector of optional, Sony RM-S410 system remote controller. For details, refer to the operating instructions of the RM-S410 system controller.
- 26 AC OUTLET
- 27 AC power cord

SECTION 1
OUTLINE

CIRCUIT DESCRIPTION

1-1. OUTLINE

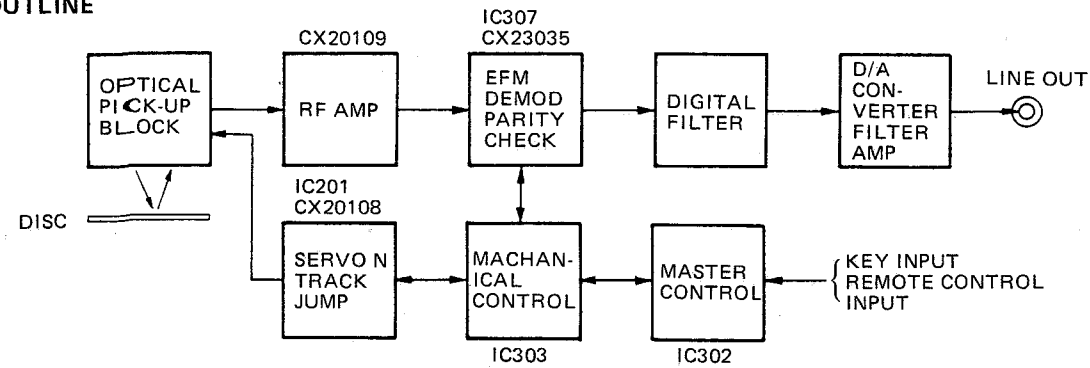

Above block diagram shows configuration of this set. Master control IC (IC302) serves as the center of all operation. Master control IC (IC302) assumes interface between man and machine like key input and remote control input. Mechanical control IC (IC303) assumes interface between master control IC (IC302) and machine.

For example, if PLAY button is pressed from key input, master control (IC302) gives mechanical control IC (IC303) a command to make PLAY mode. When this command is given, mechanical control IC (IC303) works in routine operation to make PLAY mode. It gives every kind of commands for IC201, 307 and they are in PLAY mode.

Through IC201 and IC307 use common data bus, they distinguish a command for IC201 or IC307 by a higher rank 4 bit value of each command from mechanical control IC (IC303).

Command for IC201: higher rank 4 bit 0000-0011 (0-3 with hexadecimal number system) are used.

Command for IC307: higher rank 4 bit 1010-1110 (A-E with hexadecimal number system) are used. IC201 controls servo (focus, tracking, sled) mainly. IC307 checks EFM demodulation and CRC.

The illustration below shows flow chart of simple operation after power is ON.

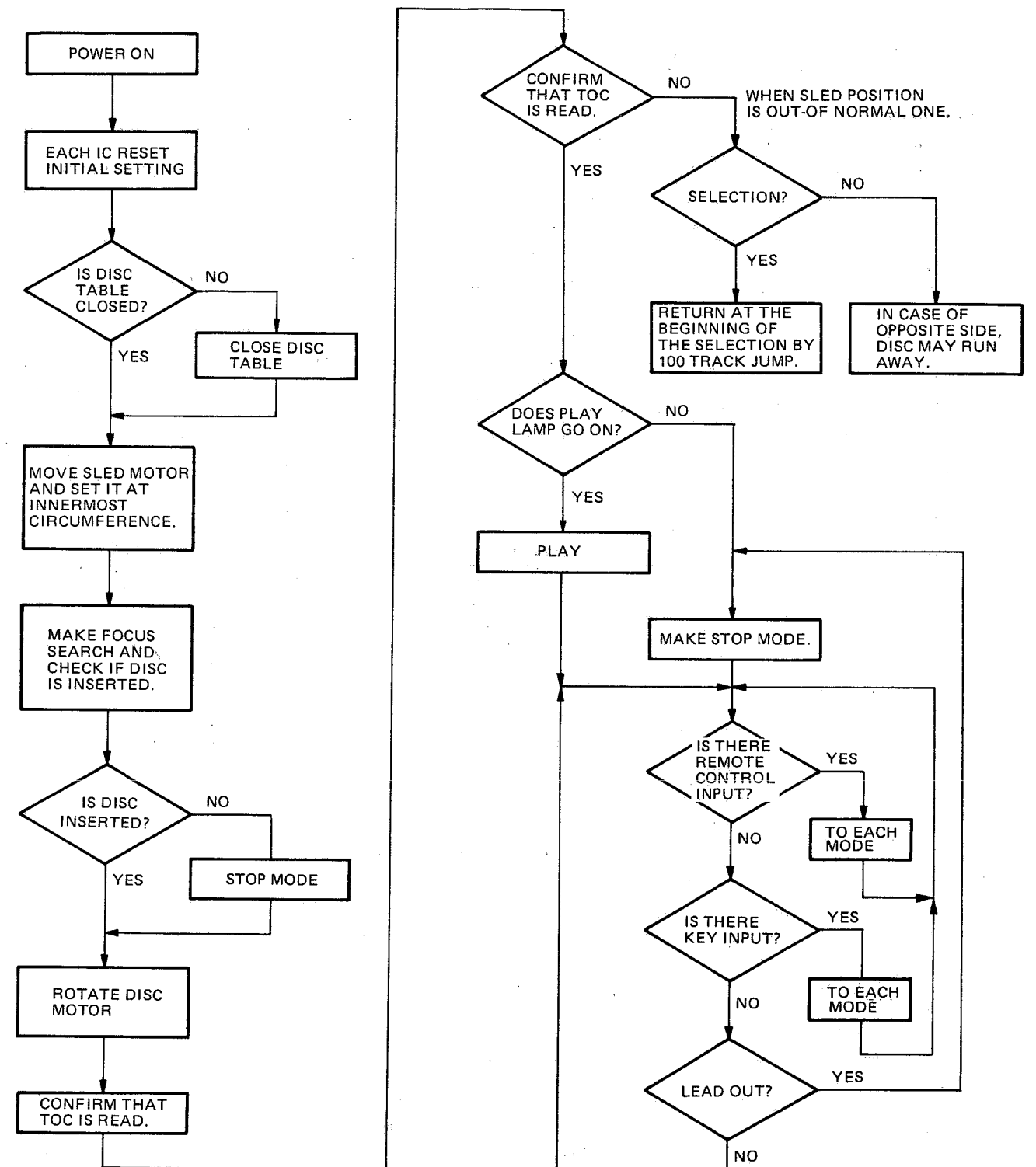

1-2. MASTER CONTROL IC (IC302)

Master control IC (IC302) controls all of the operations of this set. Besides inputting key input and remote control input and data from mechanism control IC (IC303), it outputs display output and commands to mechanism control IC303.

Pin Functions

Pin. No.	I/O	Pin Name	Operation
1-4	OUT	D0-D3	Data output pin for key scan digit signal and to display tube drive IC (IC801)
5-8	IN	K0-K3	Key scan data input pin.
9	IN	OSC	Clock input pin.
11	IN	RESET	Reset input pin. Goes high about 1.5 seconds after power on.
13	IN	Q INT	Trigger input pin when data is transferred from IC303 to IC302.
14	IN	OUT SW	Input pin, goes low when disc compartment opens. When this pin goes high, IC302 outputs load in command to IC303.
15	-	H. L.	When this pin is low, IC302 does not output load in command to IC303 even if pin 14 is high.
17	IN	REC M	Syncro REC signal input pin.
18	IN	SI CLK	Clock input pin from remote control decoder.
19	IN	IN SW	Input pin, goes low when disc compartment closes.
20	IN	SI DATA	Serial data input pin from remote control decoder.
21	-	GND	Ground
29	OUT	CD F	Direct function output pin. High is output for 600 msec when PLAY, PAUSE button is pressed during STOP mode.
30-33	IN/OUT	CMD0-CMD3	I/O pin for data with IC303.
34	OUT	M REQ	Control (request) signal output pin for commands to IC303.
35	IN	S ACK	IC303 acknowledge signal input pin.
36	OUT	RST	Reset output pin to display tube drive IC (IC810).
37	OUT	CTL	Clock output pin to display tube drive IC (IC801).
38	OUT	IDP	Output pin for data which controls display tube drive IC (IC801) characters.
39	OUT	RMS LED	RMS LED output pin.
40	OUT	PAUSE LED	PAUSE LED output pin.
41	OUT	PLAY LED	PLAY LED output pin.
42	OUT	VDD	Power supply pin (5 V)

When commands are sent from the master control IC (IC302) to the mechanism control IC, the master control IC sets the data to be sent and makes the M REQ pin go low from high, as shown in the figure. When the M REQ pin goes low, the mechanism control IC (IC303) makes the S ACK pin go low from high. At the time data is taken in to the mechanism control IC (IC303).

When the master control IC (IC302) confirms that the S ACK pin has gone low, it sets the next data and makes the M REQ pin high. When the M REQ pin goes high, the mechanism control IC (IC303) makes the S ACK pin high and reads in the data.

Example: CLOSE command. (CF)

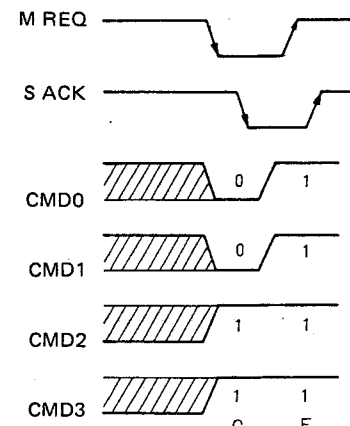

Command from master control IC (IC302) to mechanism control IC (IC303).

Command

OPEN	DF	Opens disc compartment.
CLOSE	CF	Closes disc compartment.
AMS	A * * 01F	Perform AMS. If for the 5th selection: A0501F
	TRACK NO	
INDEX	A * * * * F	Performs index search. When the INDEX key is pressed, TRACK NO and INDEX NO are input and sent.
	TRACK NO INDEX NO	
LOCATION	B * * * * * * * * OF	Performs A → B repeat. The place for A is memorized, that data is put into the * section and set out, the pick-up is returned to the place with that value, and repeats play between that point and the point where B was pressed.
	TRACK NO INDEX NO MIN SEC FRAME	
STOP	1F	Stops spindle motor and sled motor.
manual search	4F-9F	Sends out during FF and REW.
	4F	FF during PAUSE. Performs 40 track jump after a certain time passes.
	5F	REW during PAUSE.
	6F	FF Performs 10 track jump after a certain time passes.
	7F	REW
	8F, 9F	not used
PAUSE	3F	PAUSE
PLAY	2F	normal PLAY command
TOC REQ	* * * * * * * * (F)	This command is sent out when the TOC data in the mechanism control IC is desired, and is sent out during random access, when selection changes, etc.
	H L MIN SEC MIN SEC	
	(Selection N) (Selection N + 1)	

The above signals are sent from CMD0-CMD3 to the mechanism control IC.

The mechanism control IC executes these commands.

Commands sent from the mechanism control IC (IC303) to the master control IC (IC302).

TOC, Q data	C * * * * * * * * * * F	TOC data or Q data is sent.
	TRACK NO INDEX NO MIN SEC FRAME MIN SEC	
		elapsed time in the track elapsed time from beginning of disc

TOC READ END	A (F)	Sent out when TOC data read-in is finished.
LEAD OUT	B (F)	Sent out when disc ends.
NO DISC	E (F)	Sent out when there is no disc in the disc compartment.
OPEN	D (F)	Sent out when the disc compartment is open.

The mechanism control IC (IC303) keeps the TOC data and Q data read in from the disc, and sends it to the master control IC (IC302) as required.

1-3. MECHANISM CONTROL IC (IC303)

Mechanism control IC303 sends commands to IC201 (servo IC CX20108) and IC307 (digital processing/CLV servo IC CX23035) via the DATA, CLOCK and LATCH pins, and also memorizes TOC and Q data, and performs direct search, etc. based on this data.

Pin Functions

Pin No.	I/O	Pin Name	Operation
1	OUT	REC MUTE	Synchro REC MUTE signal output pin.
2	OUT	PAUSE	Synchro PAUSE release signal output pin.
3	IN	REC M	Synchro REC signal input pin.
4	-	ADJ	By making this pin low, IC303 will not load the disc out even if servo or other abnormalities are detected. Used for servo and PLL adjustment.
5	OUT	MUTE	Muting control output pin.
6	-	JMP	By making this pin low, direct search is not performed and access is done by track jump. Used for track jump check.
9	IN	OSC	Clock input pin.
11	IN	RESET	Reset input pin. Goes high about 1.5 seconds after power on.
13	IN	SCOR	SUB Q sync signal input pin.
15	IN	IN SW	Input pin; goes low when disc compartment closes.
16	IN	OUT SW	Input pin; goes low when disc compartment opens.
17	IN	FOK	Focus OK signal input pin.
18	IN	WFCK	WFCK (Write Frame Clock) input pin.
19	IN	GFS	Guard Frame Sync input pin. High is input when disc data can be read in normally.
20	IN	SUB Q	SUB Q signal (selection address, emphasis data, etc.) input pin.
21	-	GND	Ground
22	IN	SENSE	IC201, IC301 SENS output input pin.
23	IN	Q CHECK	Input pin for SUB Q CRC results output from IC307.
24	OUT	LATCH	Latch output pin for serial data to IC201, 307.
25	OUT	DIRECT	Output pin to IC201 during track jump. Normally high, reverses track jump pulse direction at low. Next, for high set to normal tracking mode. Outputs low for a set time at detection of TZC rise and fall.
26	OUT	DATA	Serial data output pin to IC201, 307.
27	OUT	CLOCK	Serial data transmission clock output pin to IC201, 307.
28	OUT	SLED G	Output pin; controls sled motor gain. Normally high. Low during access.
29	IN	SLED S	Low when sled motor operates. Inputs high when it stops.
31	OUT	Q INT	Trigger output pin for data sent to IC302.
32	OUT	S ACK	Acknowledge signal output pin for IC302 M REQ signal.
33	IN	M REQ	IC302 M REQ signal input pin.
34-37	IN/OUT	CMD0-CMD3	I/O pin with IC302 data.
38	OUT	LD ON	Output pin; controls laser diode ON/OFF.
39	OUT	LOAD IN	Output pin; drives loading motor to the close side.
40	OUT	LOAD OUT	Output pin; drives loading motor to the open side.
41	OUT	EPS	Detects disc emphasis, switches emphasis ON/OFF. Output pin.
42	-	VDD	Power supply pin (5 V)

The Q data called SUB Q is used for the TOC Table of Contents) data in the lead-in area, mode control signals such as preemphasis during the selections, and track number (TNO), index number, play time, etc. display and address data.

This data is input to mechanism control IC (IC303) SUB Q pin from IC307, and is written into the RAM by 8 bit units. Data is sent from the mechanism control IC (IC303) to the master control IC (IC302) as required, and is displayed. Data is sent from the mechanism control IC to the master control IC about 8 times in 1 second.

1-4. DIRECT SEARCH

On this set, a linear motor is used for the sled motor, so that besides 100, 10 and 1 track jump, the optical pick-up can be moved directly to the address specified by the microcomputer. (direct search). (On the conventional CD player, only the objective lens moves, and the optical pick-up follows it by servo in order to perform 100, 10 and 1 track jump only.) Higher performance access is enabled on this set.

On the conventional CD player, only three data, A0 (MNR of first selection on the disc), A1 (MNR of last selection on the disc) and A2 (leadout track start point) were memorized when TOC data was read in to the microcomputer. However, on this model, the absolute time from the first to the 21st selection is memorized in the microcomputer. This absolute time is converted to track numbers inside the microcomputer, and the track number to be jumped is obtained by subtracting the current address track number from the track number of the selection to be jumped to.

Frame number	POINT	PMIN, PSEC, RFRAME
n	01	00, 02, 32
n + 1	01	00, 02, 32
n + 2	01	00, 02, 32
n + 3	02	10, 15, 12
n + 4	02	10, 15, 12
n + 5	02	10, 15, 12
n + 6	03	16, 28, 63
n + 7	03	16, 28, 63
n + 8	03	16, 28, 63
n + 9	04	. .
n + 10	04	. .
n + 11	04	. .
n + 12	05	. .
n + 13	05	. .
n + 14	05	. .
n + 15	06	49, 10, 03
n + 16	06	49, 10, 03
n + 17	06	49, 10, 03
n + 18	A0	01, 00, 00
n + 19	A0	01, 00, 00
n + 20	A0	01, 00, 00
n + 21	A1	06, 00, 00
n + 22	A1	06, 00, 00
n + 23	A1	06, 00, 00
n + 24	A2	52, 48, 41
n + 25	A2	52, 48, 41
n + 26	A2	52, 48, 41
n + 27	01	00, 02, 32
n + 28	01	00, 03, 32
.	.	. .
.	.	. .
.	.	. .

- Frame number: 98 symbol, 1 block No.
- POINT = For A0, PMIN indicates MNR of first selection on the disc. PSEC, PFRAME are "00".
- POINT = For A1, PMIN indicates MNR of last selection on the disc. PSEC, PFRAME are "00".
- POINT = For A2, PSEC, PFRAME indicate lead-out track start point.
- POINT = For 01-06, PMIN, PSEC indicate the absolute time of the selection.

Table A. TOC Structure (Example of a 6 selection disc)

Direct search is performed as follows:

When the search command is input to the mechanism control to (IC303) from the master control IC (IC302) due to key input or remote control input, the mechanism control IC303 converts the current address to track number from the data Q of the current address channel Q (Figure 1) data. (This data Q is always input from pin 20 SUB Q during play.) The address to be jumped to is also converted to a track number, the track numbers are compared, and the number of tracks to be jumped is calculated.

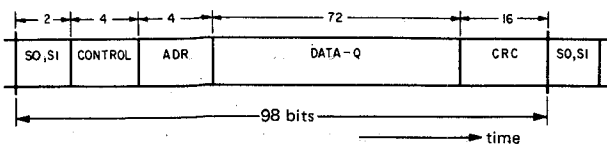

SO, S1: parts of sync pattern.
 CONTROL: Indicates channel number and preemphasis ON/OFF.
 Output from MSB
 0000 - 2CH, no pre-emphasis
 1000 - 4CH, no pre-emphasis
 0001 - 2CH, pre-emphasis
 1001 - 4CH, pre-emphasis
 LSB = 0 at lead-in and lead-out portions.
 ADR: Control bit for DATA-Q. Output from MSB.
 DATA-Q: 72 bits of data; output from MSB.
 CRC: CRC for CONTROL, ADR, DATA-Q. Refer to PCM-F1 Operation Manual for details on CRC.
 Output from MSB.
 Generation multinomial is
 $P(x) = X^{16} + X^{12} + X^5 + 1$

Figure 1. Channel Q Structure

- Data Form on Lead-in Track (indicate TOC) -

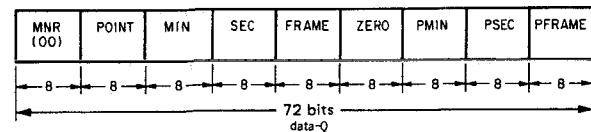

- Data Form of Music Signal and Lead-out Track -

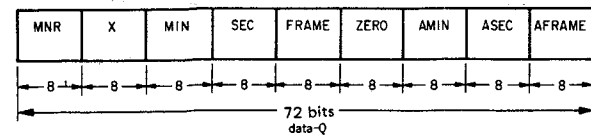

MNR: Expresses Music Number as 2 digits of BCD.
 00 → Lead-in track
 01-99 → Music number
 AA → Lead-out track
 X: MNR index, expressed as 2 digits of BCD.
 1 MNR is divided into 100. The method of division is determined by the software, and numbering is in order from "00-99". Does not exist on lead-in track.
 00 → Pause encoding
 Applies pause. There is 2-3 seconds of pause encoding at the top of the selection.

01-99 → Sub-division number.

X = 01 on the lead-out track, MNR = 01-99 and X ≠ 00 during a selection. Initial value is "01", then increases by ones.

ZERO: All these 8 bits are "0".

MIN, SEC, FRAME: Selection running time is expressed by BCD 6 digits. All "0" at beginning of selection. Time increases during the selection, stops at pause. Become "0" at end of pause. Time increases on lead-in and lead-out tracks. 1MIN = 60 SEC, 1SEC = 75 FRAME (00-74)

AMIN, ASEC, AFRAME: Disc running time is expressed as BCD 6 digits. At start of disc program area, time is "0" and MNR is the first value of that disc. 1AMIN = 60 ASEC, 1ASEC = 75 AFRAME (00-74)

POINT, PMIN, PSEC, PFRAME: Disc table of contents is on this part of the lead-in track. As shown in the table, it is recorded continuously and repeatedly on the lead-in track, or MNR = 00 portion. Also, each content is recorded 3 times each.

PMIN, PSEC, PFRAME values each express selection start point. There is ±1 second precision on AMIN, ASEC, AFRAME time axes.

Figure 2. Data Q Structure

Next, the mechanism control IC puts the digital signal processing/CLV servo IC (IC307) CX23035 into counter set mode. By doing this, CX23035 outputs the CNIN pin (17) input signal CNIN/2h (Hz) signal from SENSE pin (18) (COUNT). At this time 41 is set in n, so a signal which is the input signal divided by 82 is output from the SENSE pin.

Then tracking and sled servo go off, focus servo goes on and the optical pick-up is moved quickly by the linear (sled) motor. When this happens the RF amp (IC201) CX20109 MIRR pin (18) mirror output is as shown in Figure 3. (For example, if there are 20000 tracks from the innermost to outermost circumference, and access is done in 0.5 seconds, mirror output is 40 kHz, which is too fast for the mechanism control IC to read.)

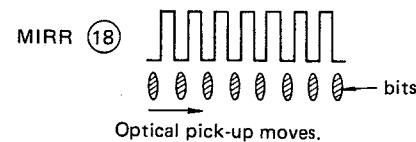

Figure 3. Mirror Output for Direct Search

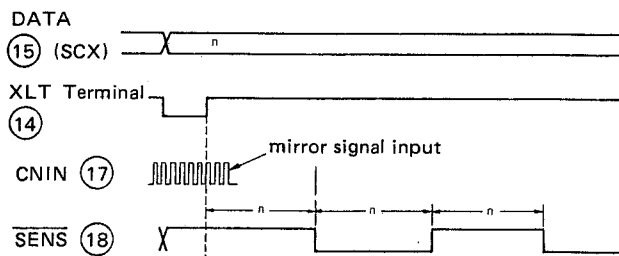
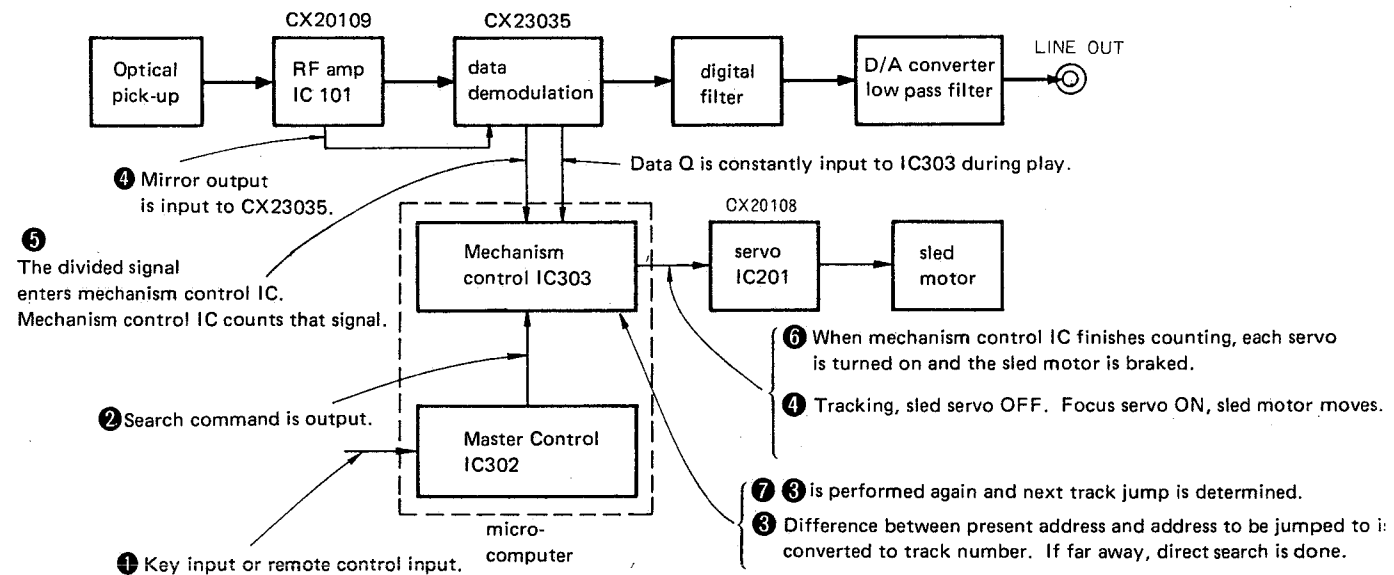

Figure 4. Count Signal Timing

This mirror output is input to CX23035 CNIN pin (17), then is divided into 41 and output from SENSE pin (18) to the mechanism control IC SENSE pin (22). (At this time, it is divided and can be read.) This input signal is counted by the mechanism control IC at rise or fall and is converted to the number of tracks to be jumped. For example, for a 1000 track jump, consecutive comparison, such as $1000/82 \approx 12$ is done and when that value is reached, each servo is turned on and the optical pick-up is braked. Then DATA-Q is read, converted to track number, and if within a certain range, 100, 10, 1 track jump are performed and convergence is done. Outside of that range, direct search is performed again.



1-5. LINEAR MOTOR AND SERVO CIRCUITS

A linear motor is used for optical pick-up transportation mechanism on this model.

Figure a shows the optical pick-up transportation mechanism. The linear motor drive coil (sled coil) is part of the optical pick-up and performs transporta-

tion operation. There is a sensor coil mounted on the opposite side of the linear motor. This detects when the optical pick-up reaches the innermost circumference and stops the linear motor.

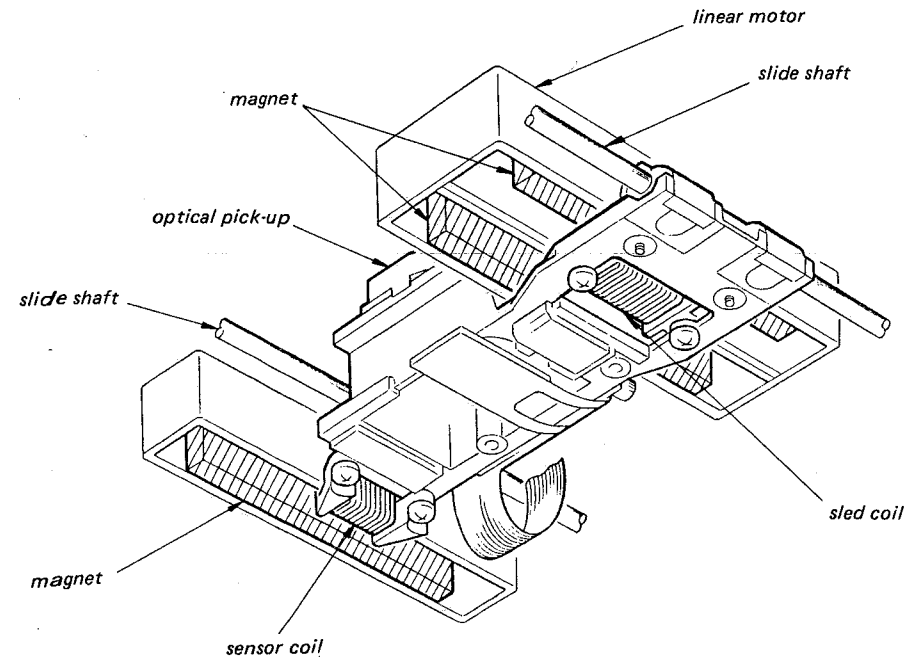

Figure a. Optical Pick-up Transportation Mechanism

The linear motor is structured with a coil wound around a yoke plate and a magnet at both ends. Figure b shows the theory of operation. The coil re-

ceives force in the direction of (A) when current flows to the coil in the magnetic field.

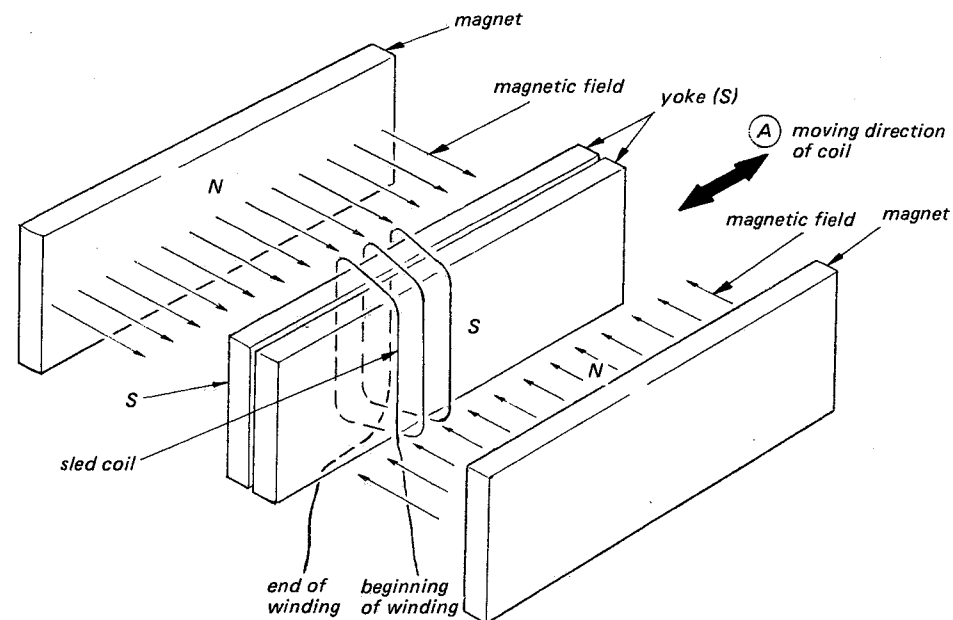
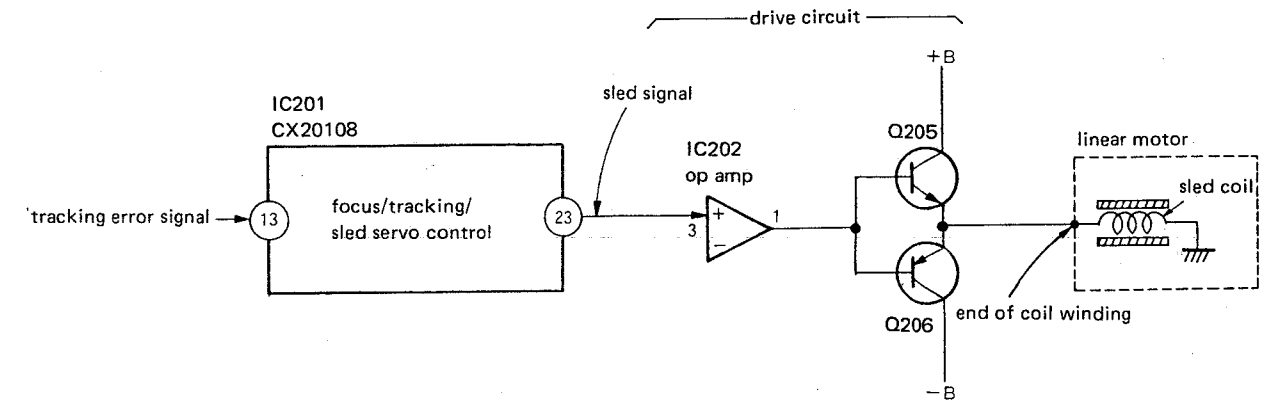

Figure b. Theory of Linear Motor Operation

The linear motor servo circuit receives a tracking error signal at CX20108 (IC201) servo control in order to prevent the optical pick-up laser spot from leaving the pit track, and outputs a sled signal. This sled signal drive controls the linear motor. Also, to

perform 1, 10, 100 track jump, the signal from IC303 (mechanism control) is controlled at IC201 (CX20108) and the linear motor is driven by the sled signal. This allows 1, 10, 100 track jump to be performed smoothly.



Linear Motor Servo Circuit Structure

CDP-302/302ES/520ES CDP-302/302ES/520ES

SECTION 2 BLOCK DIAGRAM

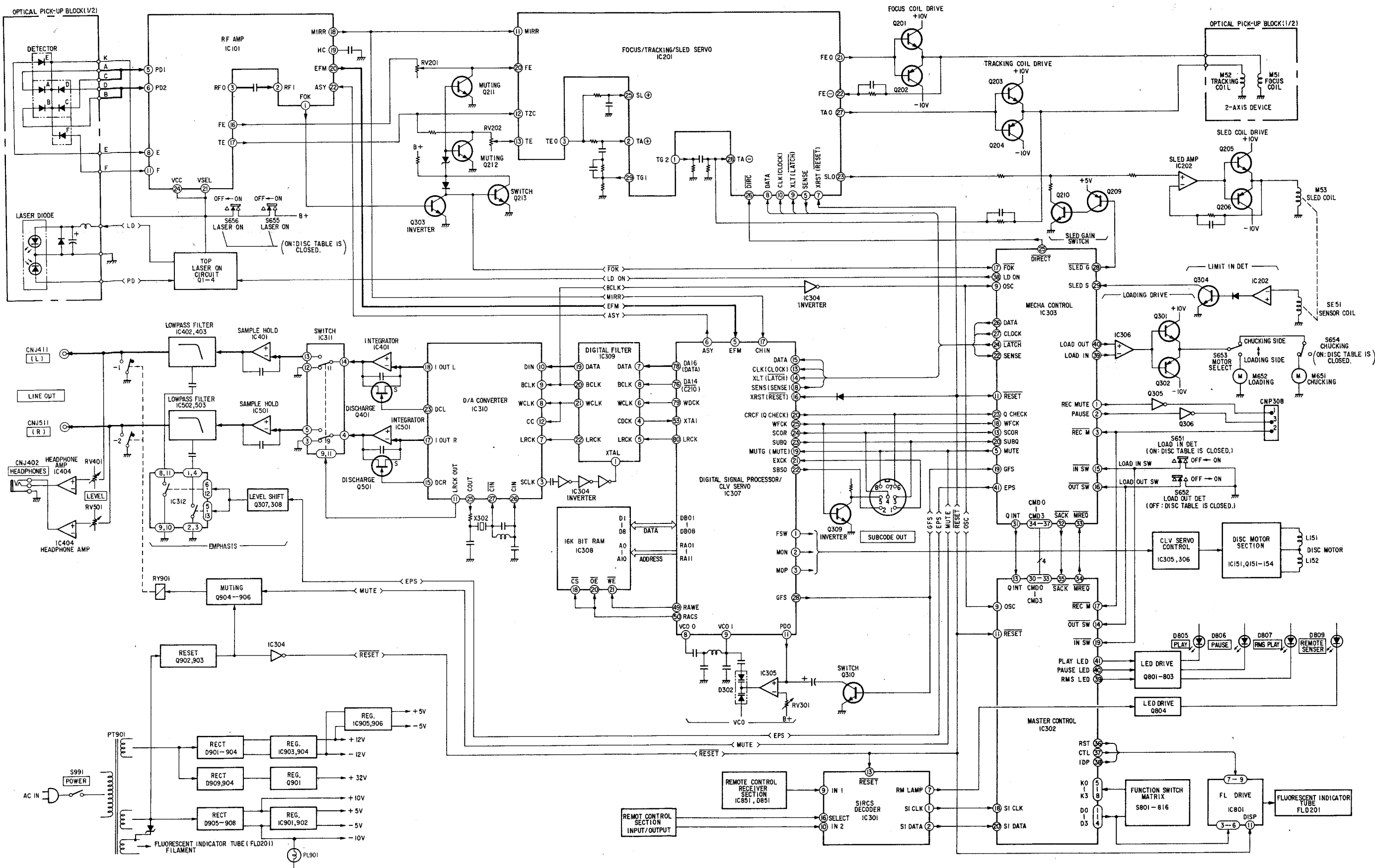

SECTION 3
DISASSEMBLY

3-1. DISASSEMBLY

Note: Follow the disassembly procedure in the numerical order given.

- Remove case by taking out seven screws:
both sides, 4 pcs.
rear side, 3 pcs.

MAIN BOARD CONNECTOR LAYOUTS

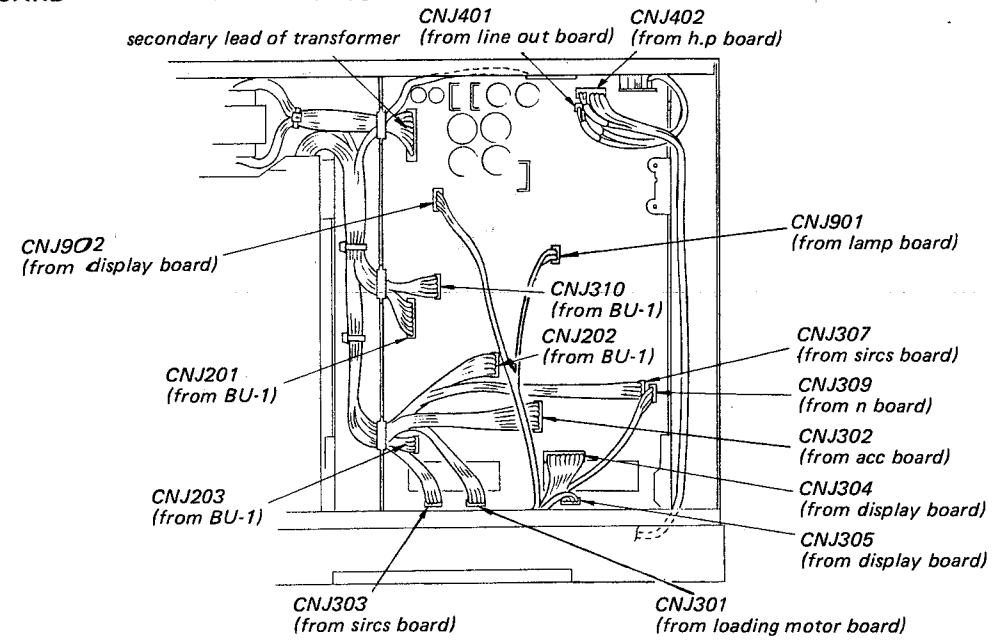

MD SECTION

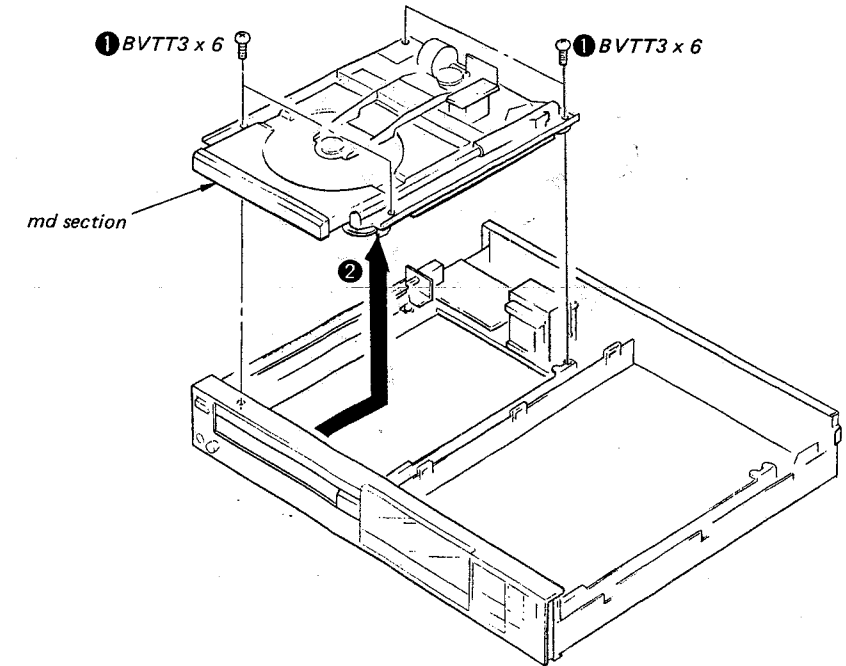

- Remove bottom plate.
(BVT3 x 8 8 pcs.)

MAIN BOARD

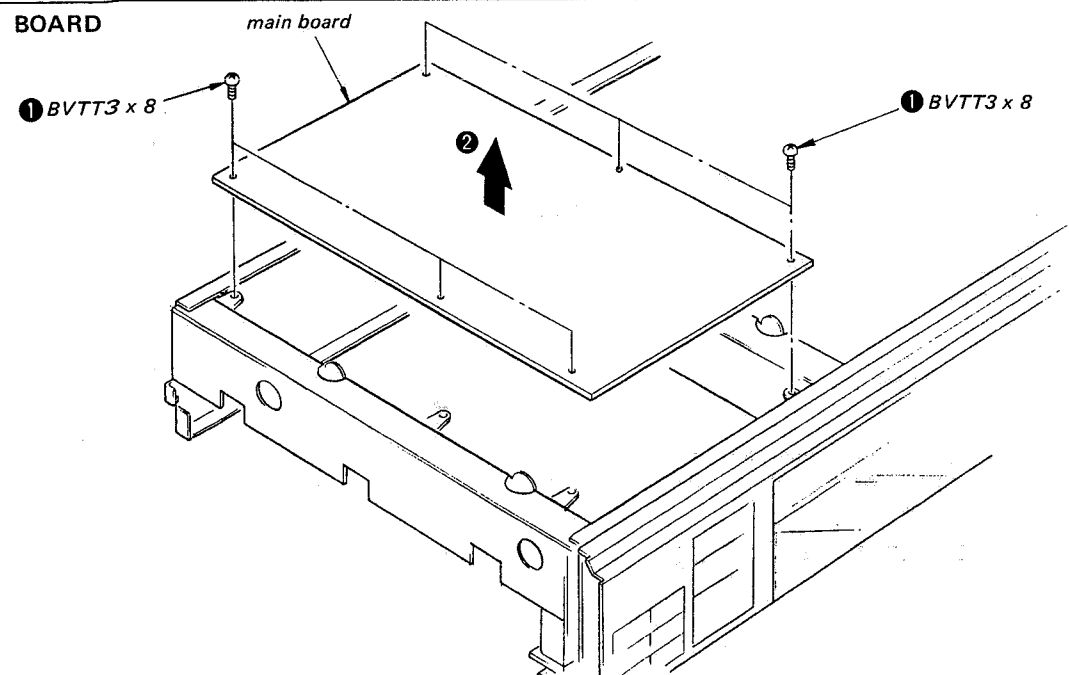

BSL MOTOR BOARD

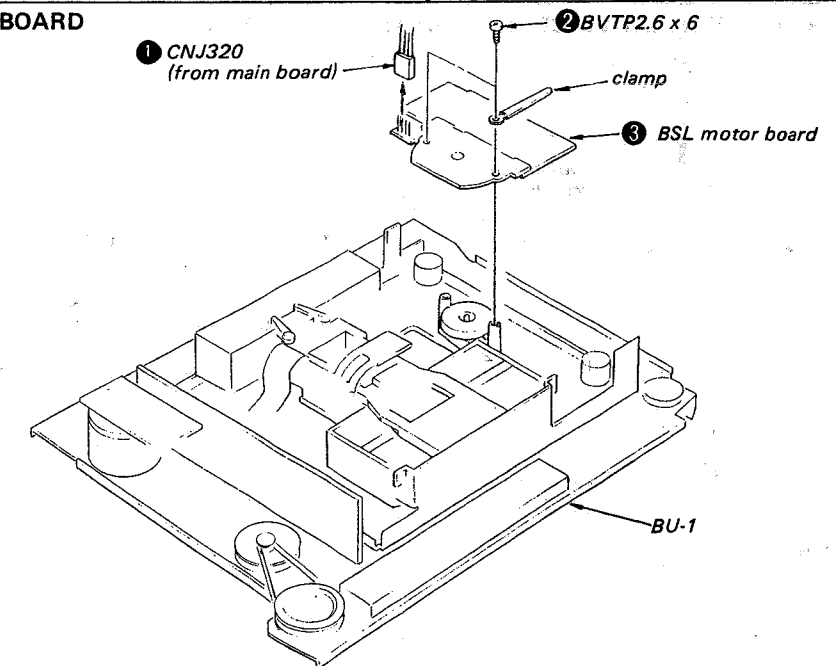

SWITCH BOARDS

- All wires of each sw board are connected to loading motor board.

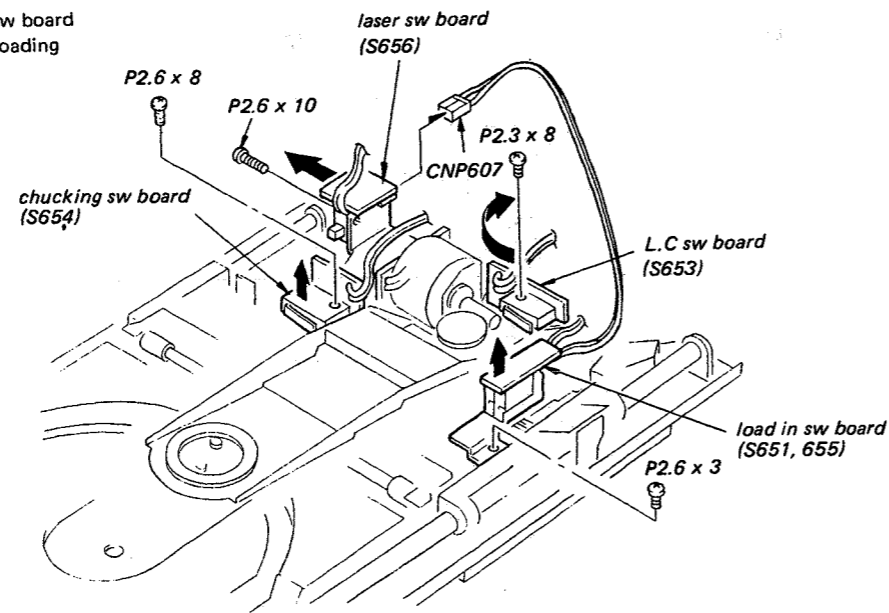

CHUCKING MOTOR (M651)

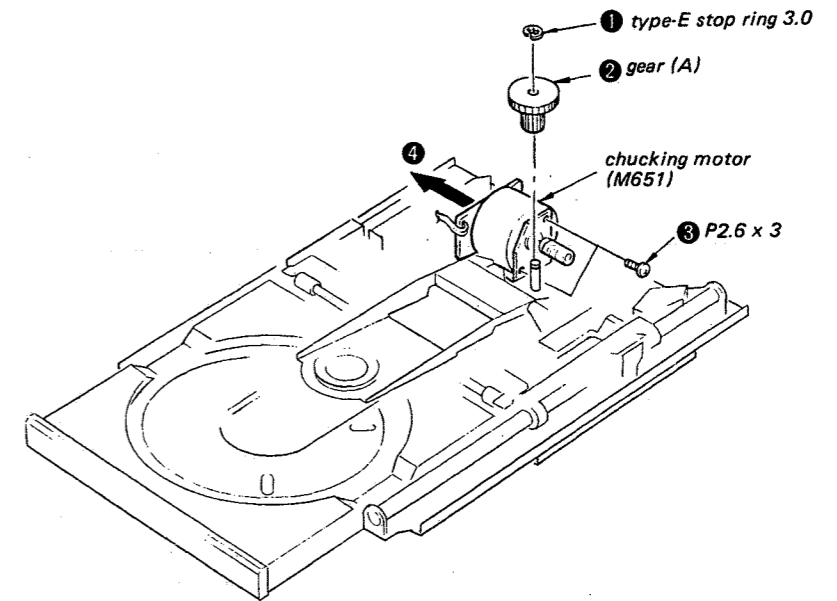

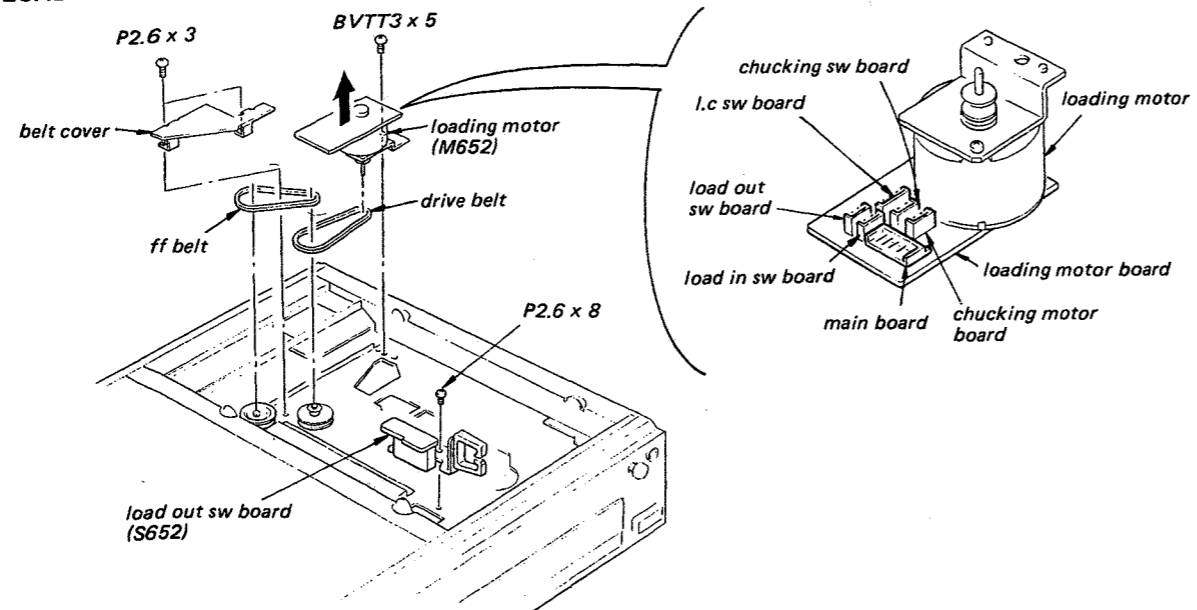

LOADING MOTOR, FF BELT, DRIVE BELT, LOAD OUT SW BOARD

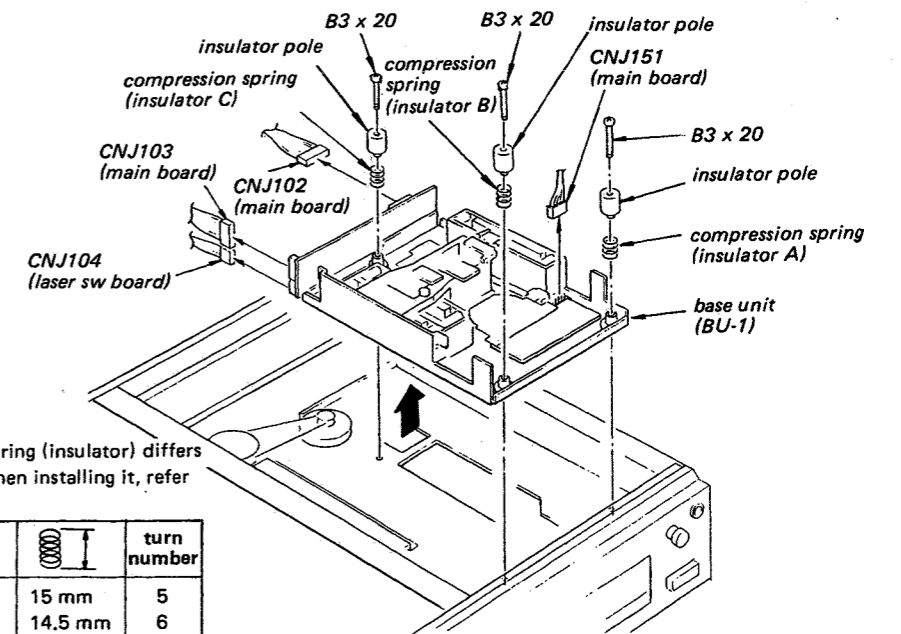

BASE UNIT (BU-1)

- Note (1):** When replacing BU-1, refer to "NOTES ON HANDLING BASE UNIT (BU-1)" on page 5 to prevent damage caused by static electricity.
- Note (2):** Each compression spring (insulator) differs in size and turns. When installing it, refer to the following list.



compression spring (insulator)		turn number
A	15 mm	5
B	14.5 mm	6
C	20.5 mm	5

Refer to "NOTES ON HANDLING BU-1 (BASE UNIT)" on page 5 to prevent damage caused by static electricity.

Refer to "NOTES ON HANDLING BU-1 (BASE UNIT)" on page 5 to prevent damage caused by static electricity.

FLEXIBLE BOARD

Unsolder marked portion of ref. no. 3, 5, and 6 and remove flexible board.

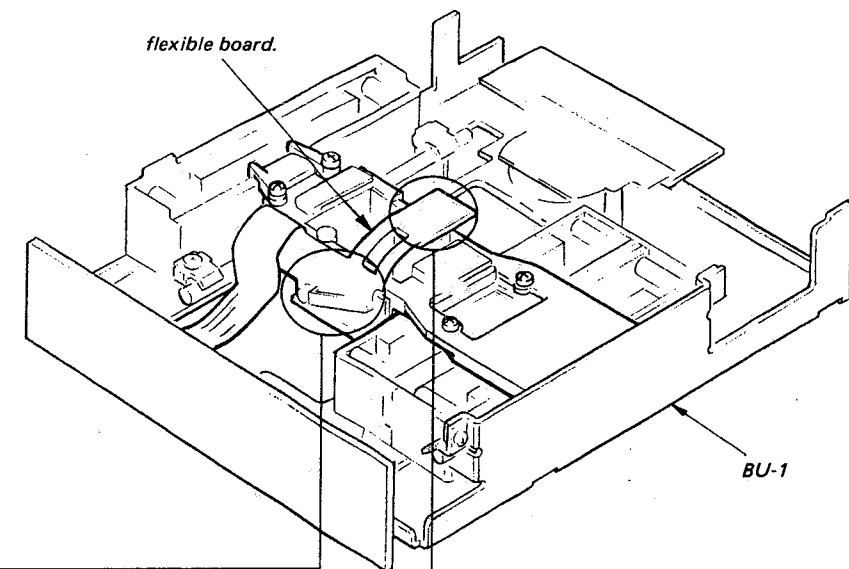
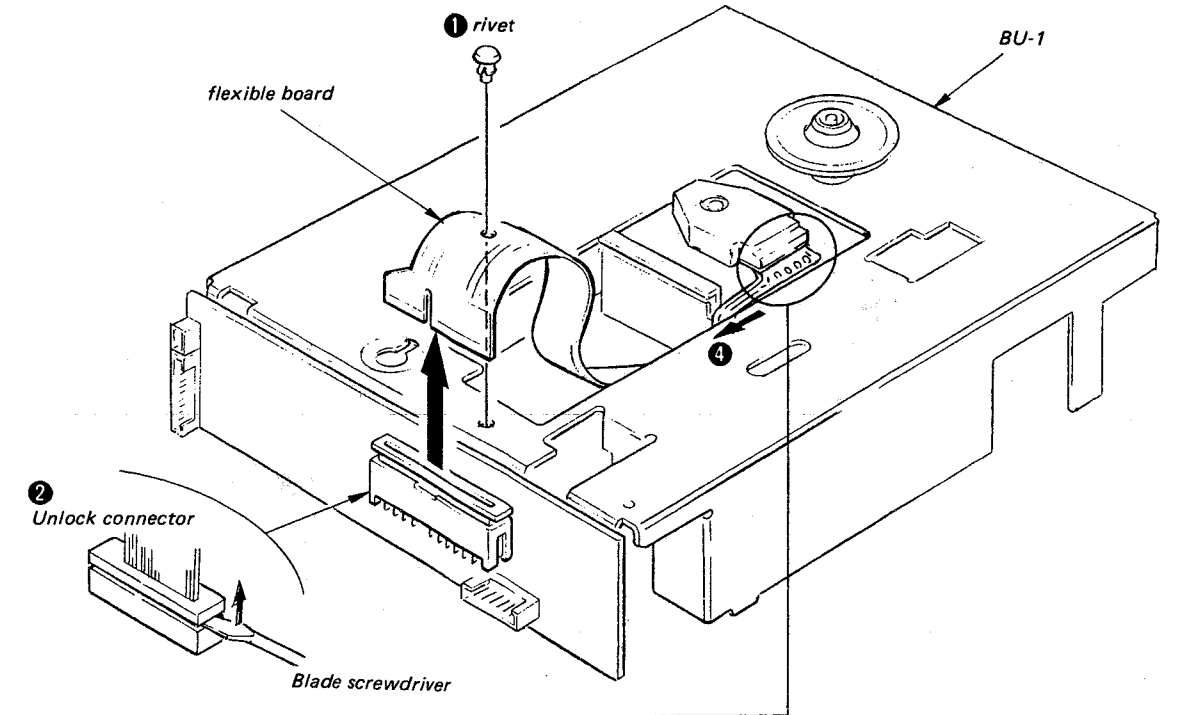
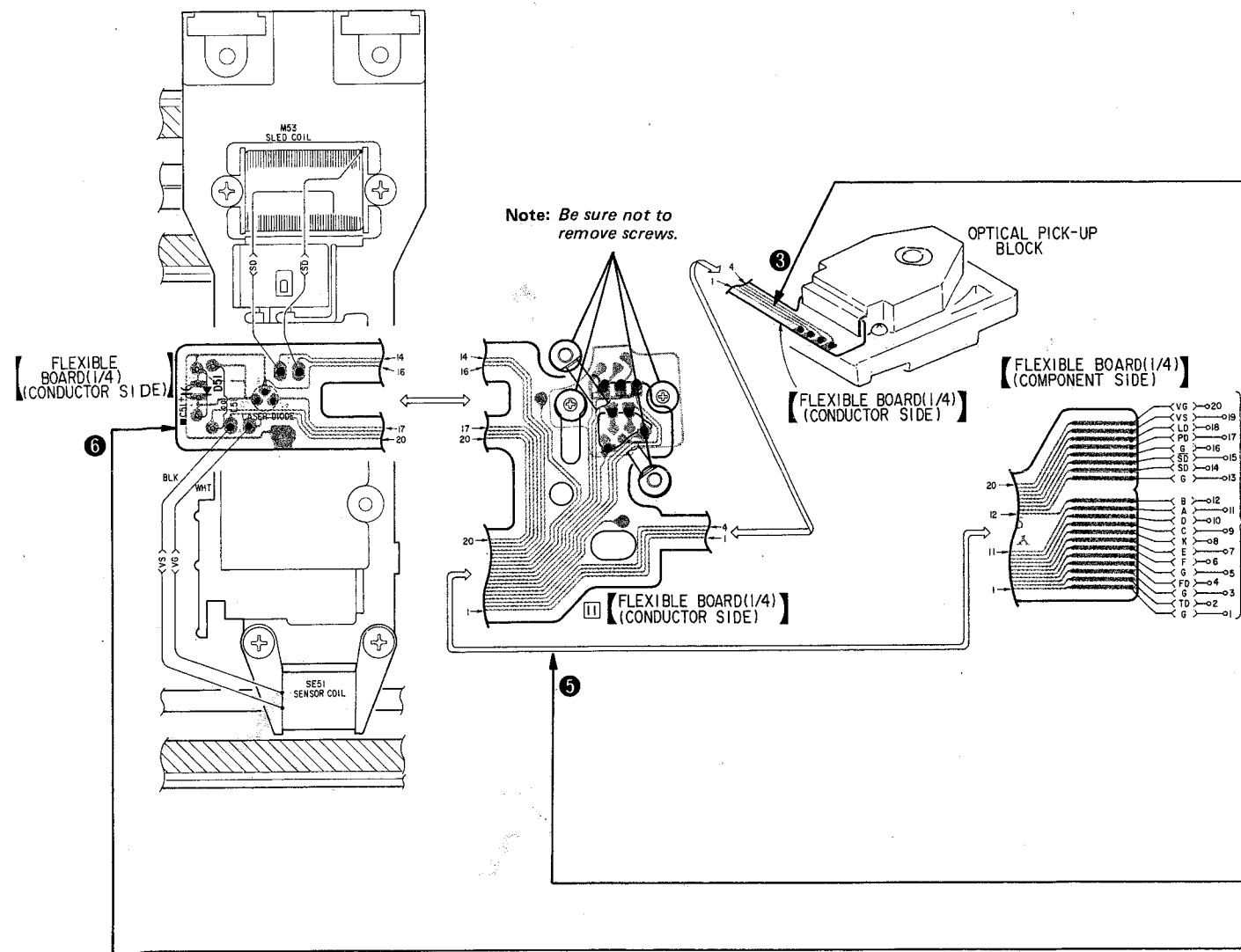

Refer to "NOTES ON HANDLING BU-1 (BASE UNIT)" on page 5 to prevent damage caused by static electricity.

Refer to "NOTES ON HANDLING BU-1 (BASE UNIT)" on page 5 to prevent damage caused by static electricity.

SLED/SENSOR COIL (1)

Open lid of lead retainer (A) as illustrated.

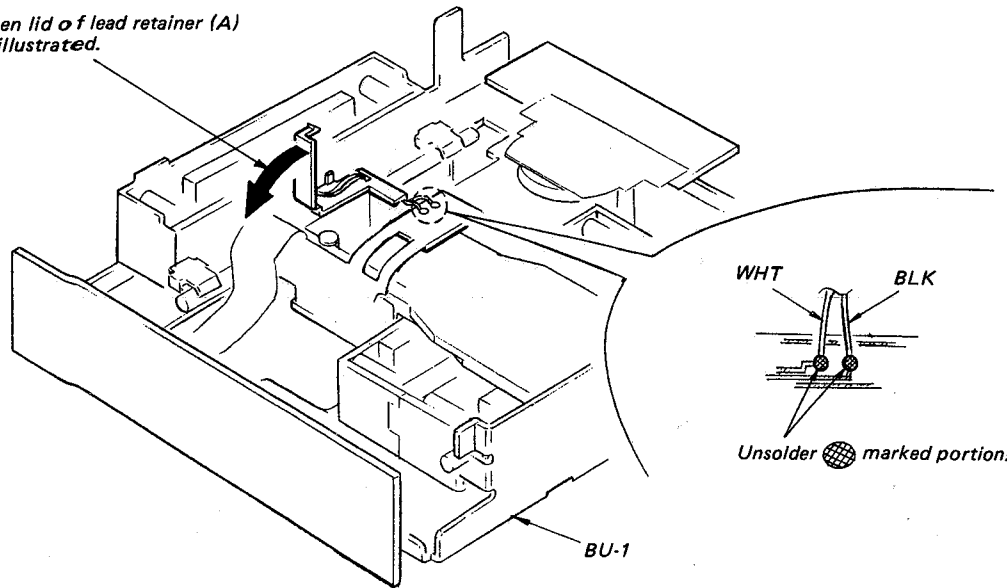

Unsolder marked portion.

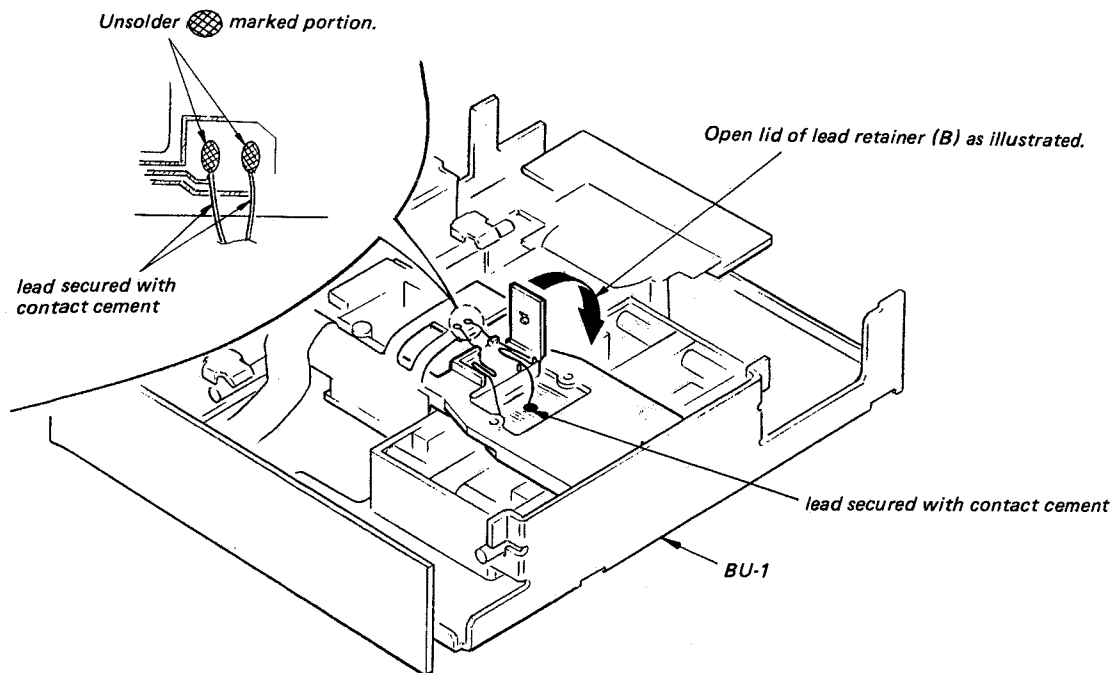

SLED/SENSOR COIL (2)

1 Perform flexible board removal 1, 2.

2 B2.6 x 5

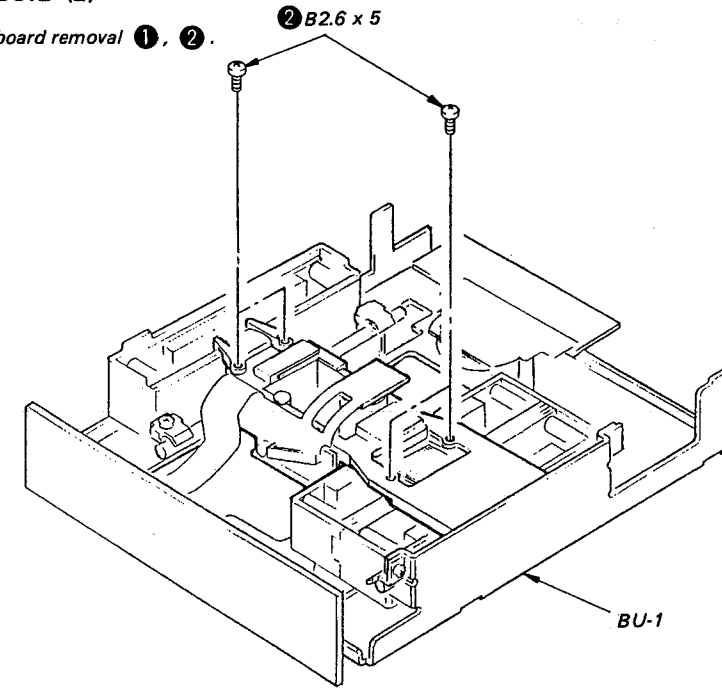

SLED/SENSOR COIL (3)

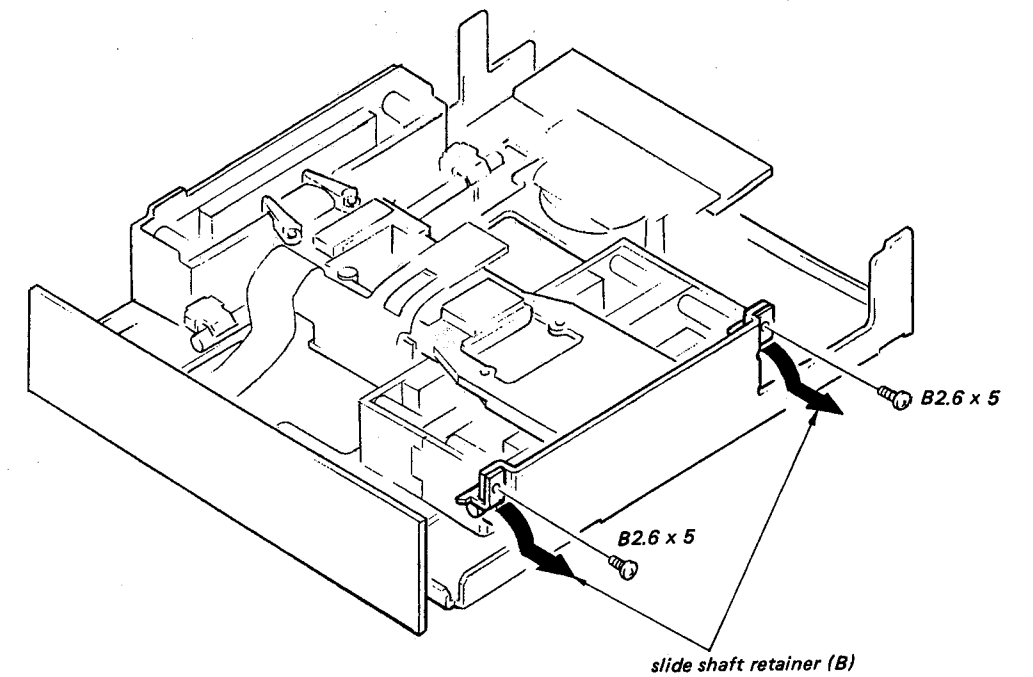

Refer to "NOTES ON HANDLING BU-1 (BASE UNIT)" on page 5 to prevent damage caused by static electricity.

Refer to "NOTES ON HANDLING BU-1 (BASE UNIT)" on page 5 to prevent damage caused by static electricity.

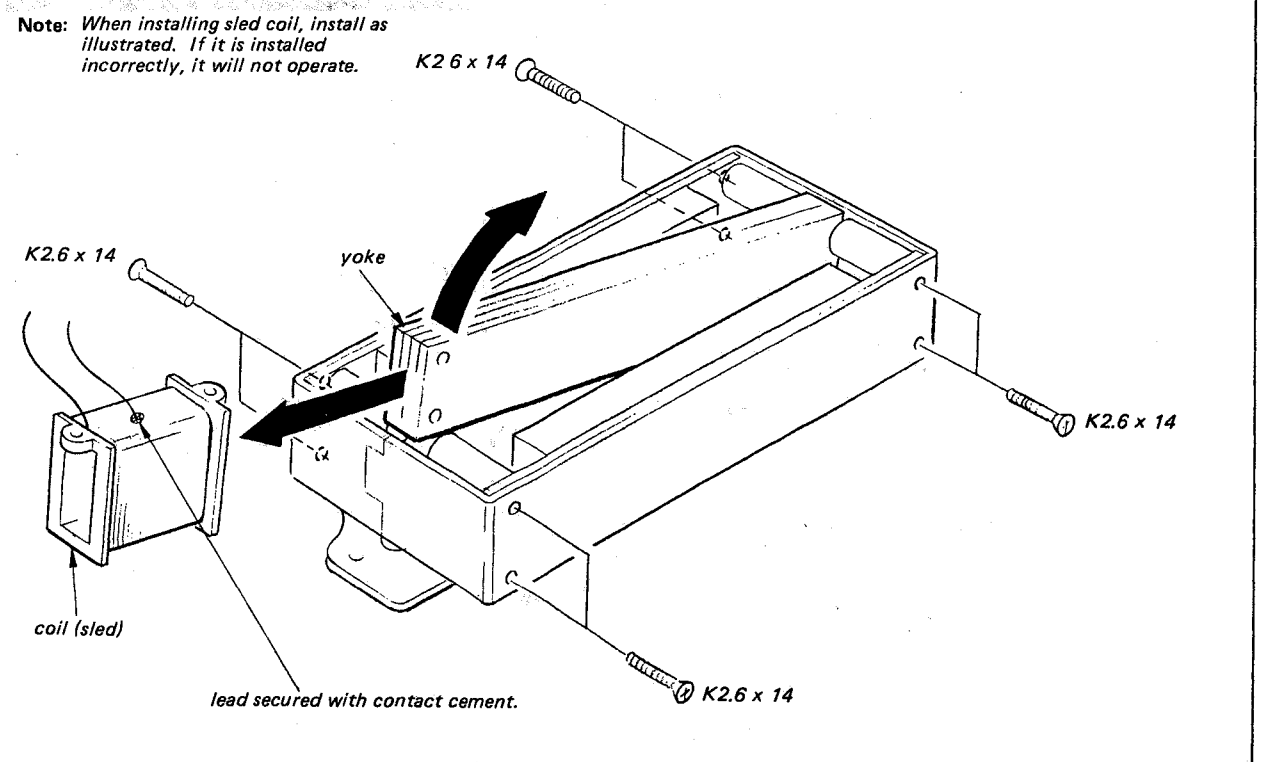
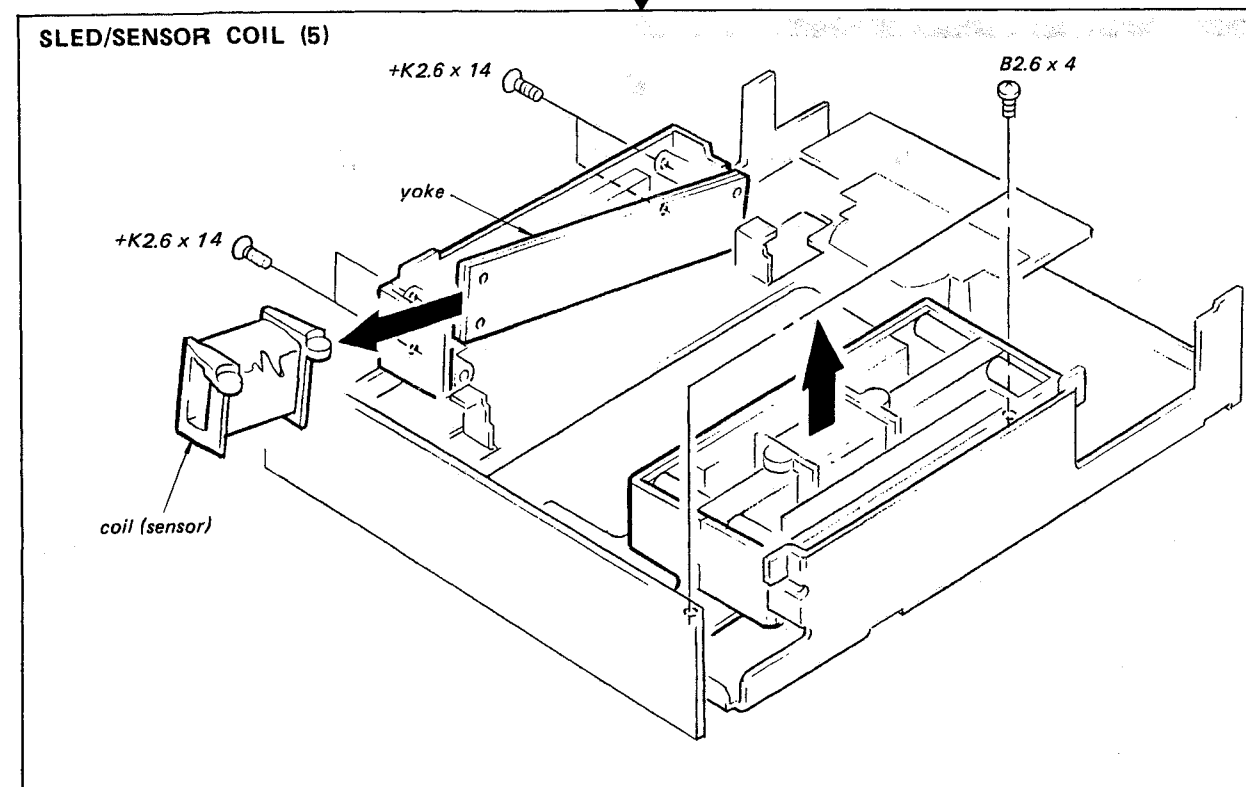
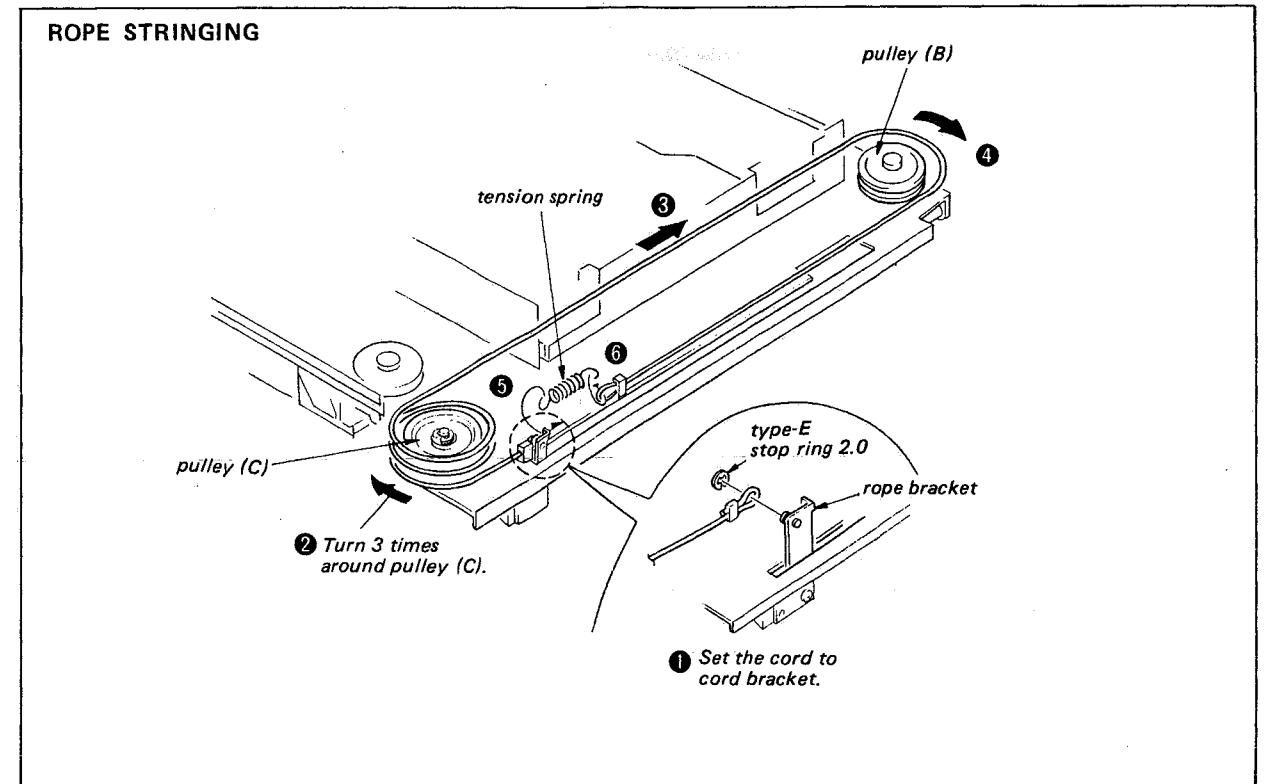
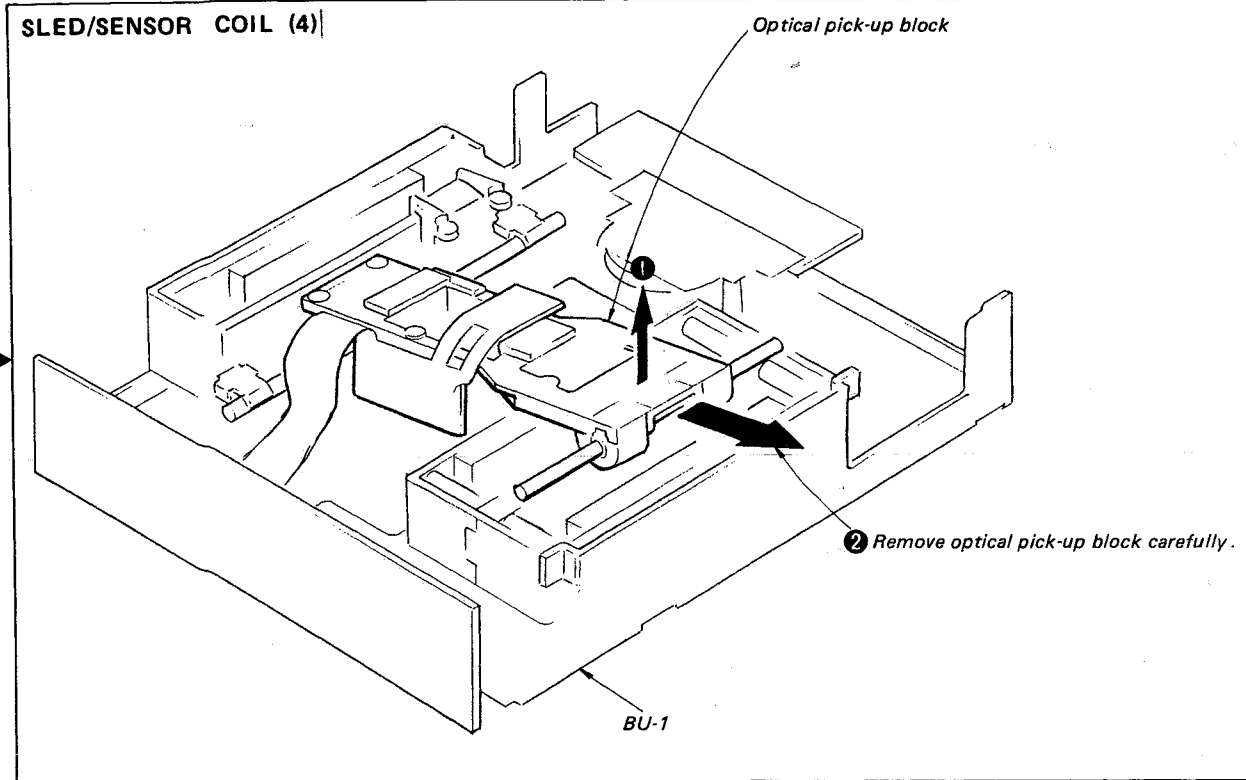

● Remove case by taking out seven screws:
both sides, 4 pcs.
rear side, 3 pcs.

FRONT PANEL

① Remove each connector.

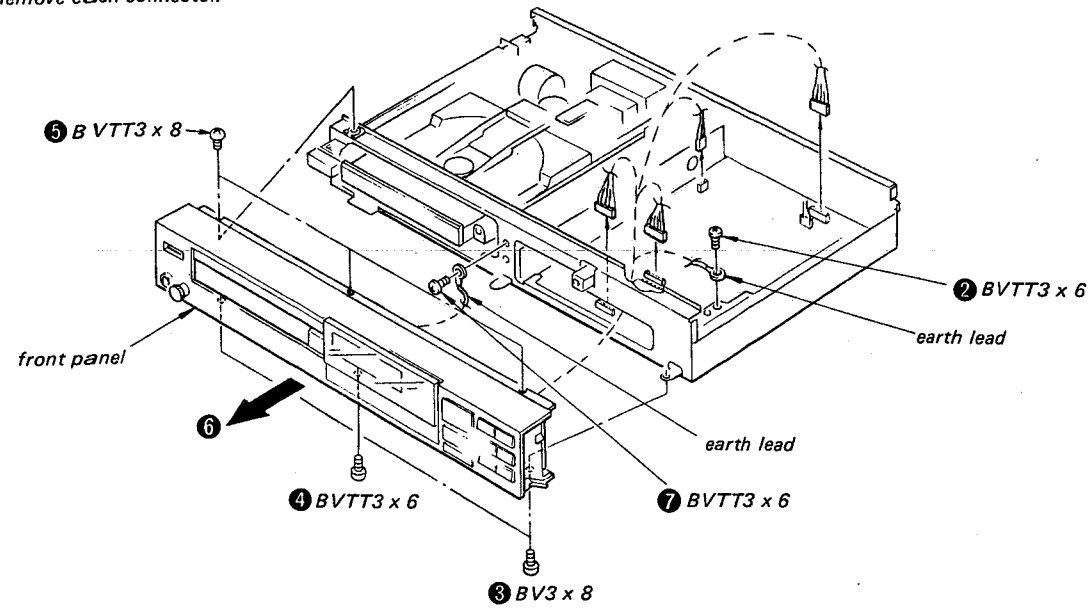

REMOTE SENSOR

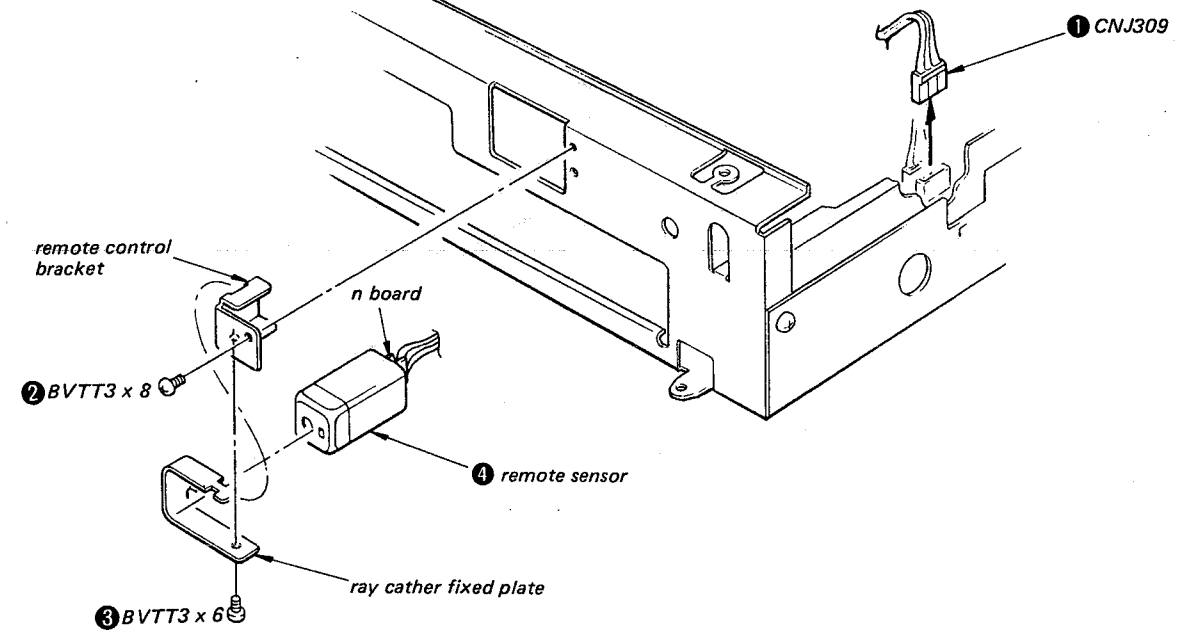

DISPLAY BOARD, H.P. BOARD

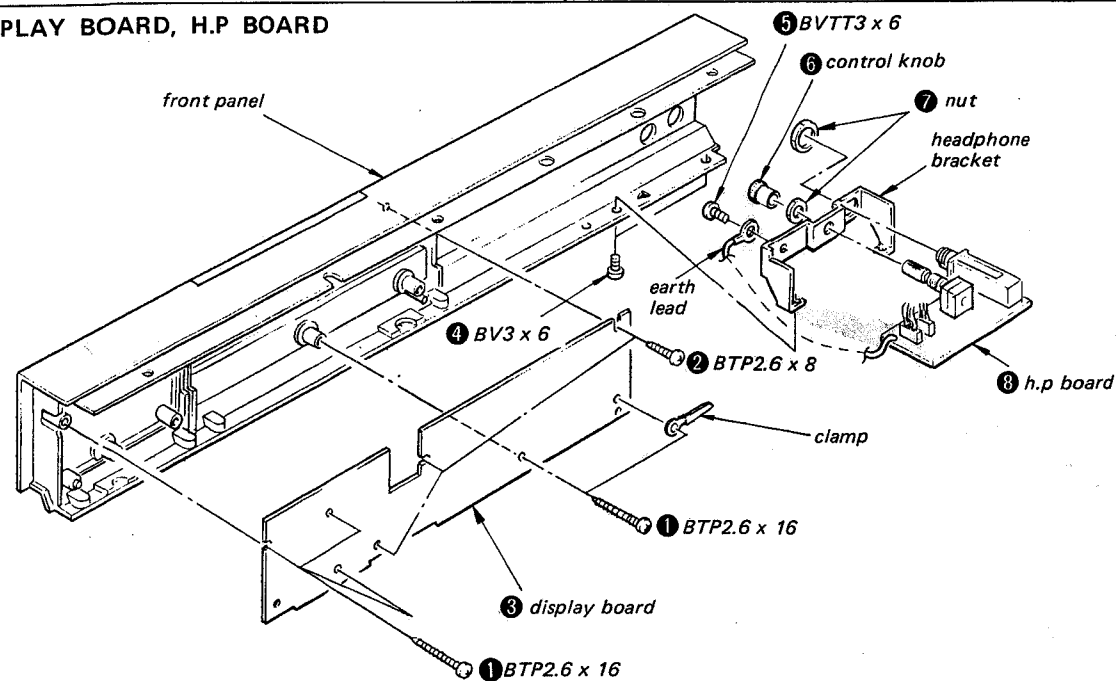

P. SW BOARD

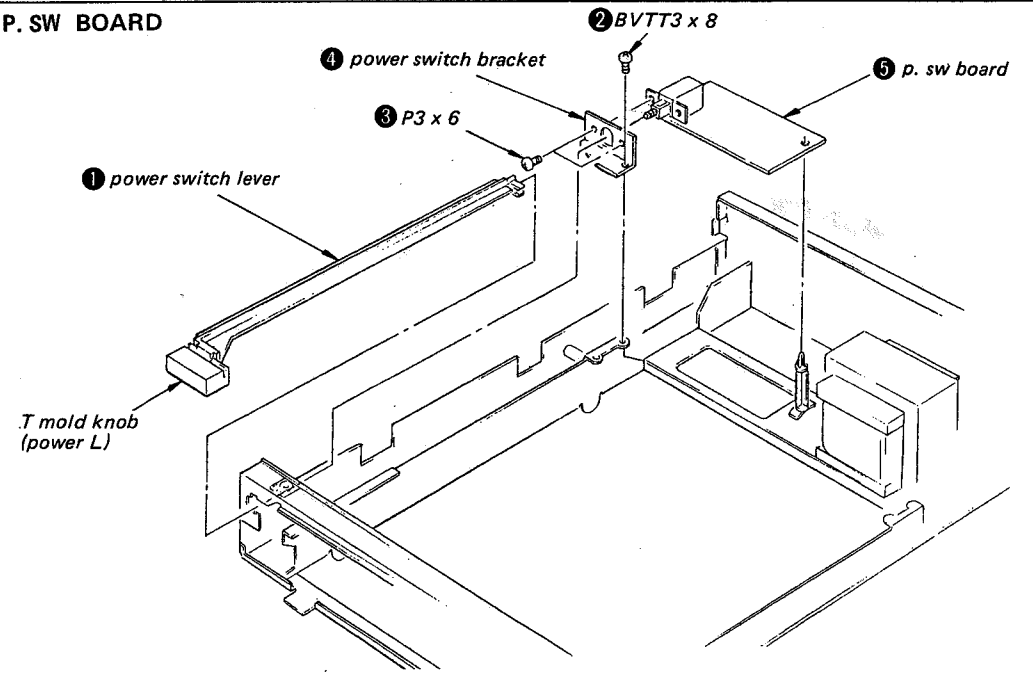

3-2. PC BOARD LOCATION

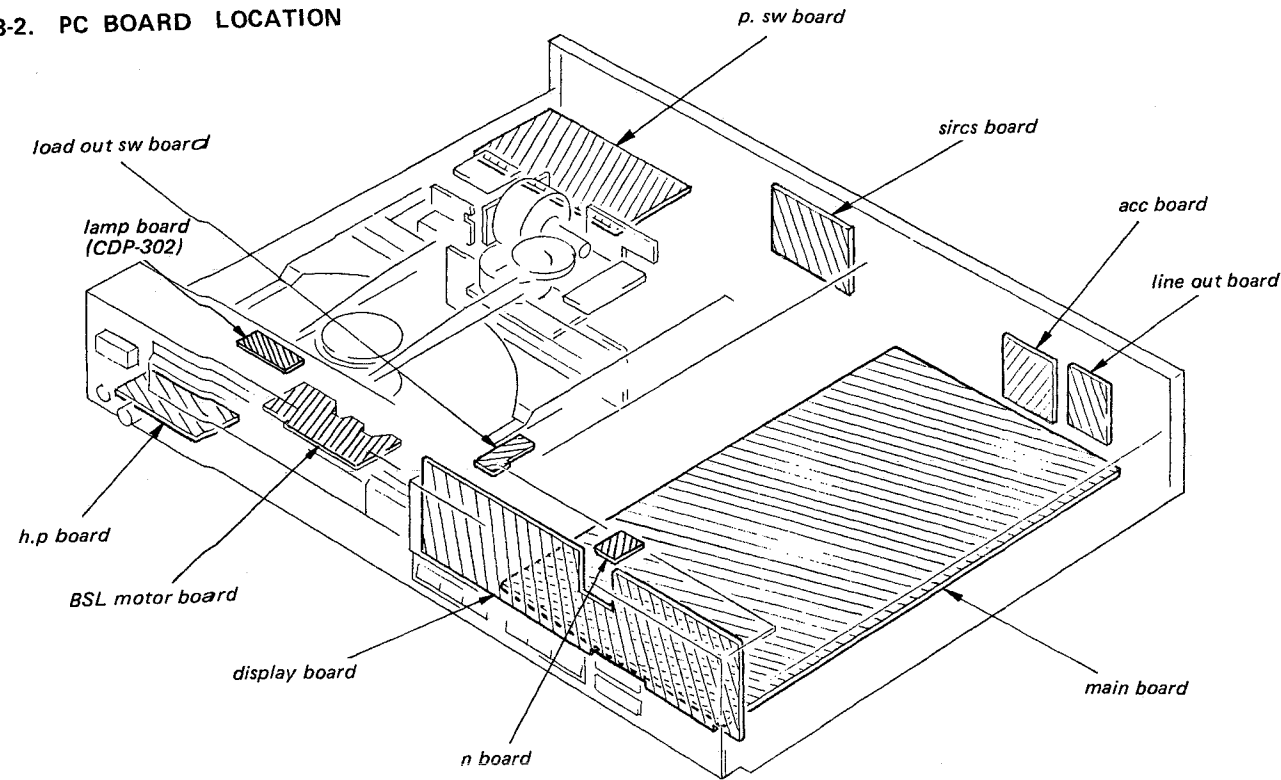

MECHANICAL SECTION

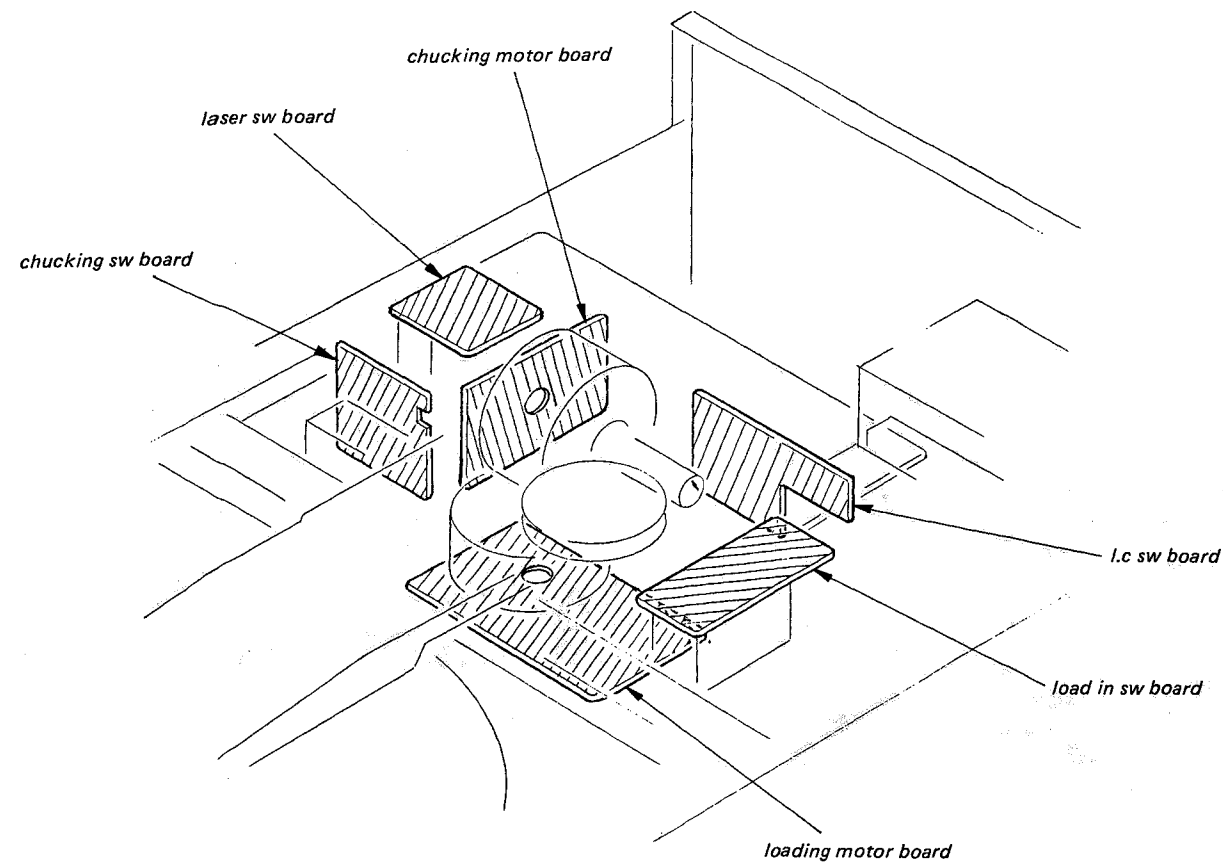

4-1. MECHANICAL ADJUSTMENT
DISC TABLE POINT ADJUSTMENT

- Setting:
- Turn power on.
 - Keep disc table closed.

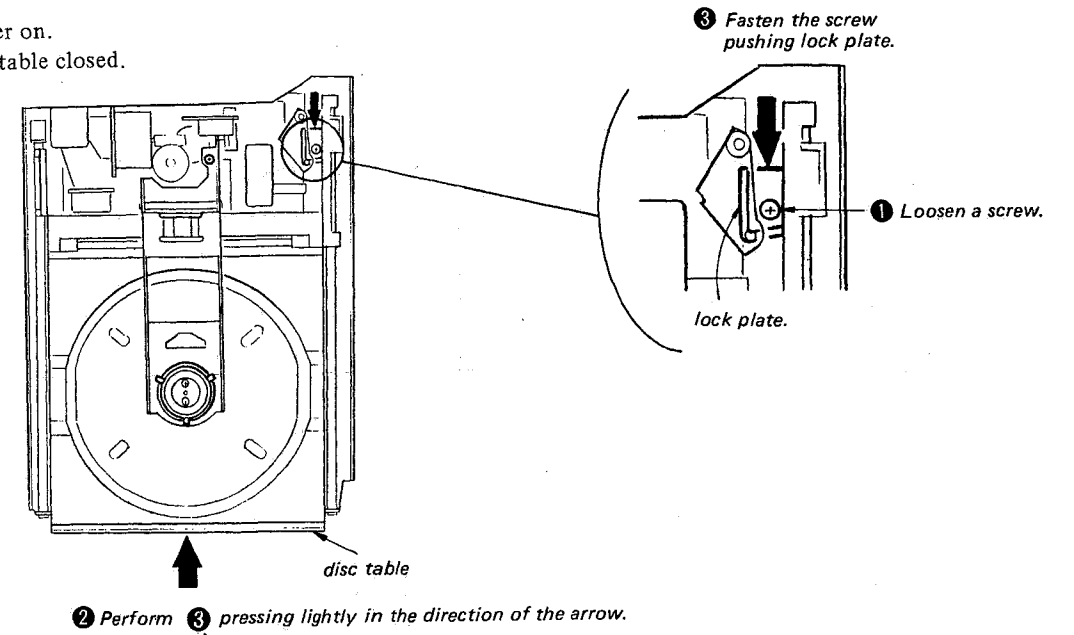

CHUCKING ARM HEIGHT ADJUSTMENT

Adjust the height of portion (A) with disc inserted and disc table closed.
Repeat loading and confirm that chucking arm does not touch disc pulley.

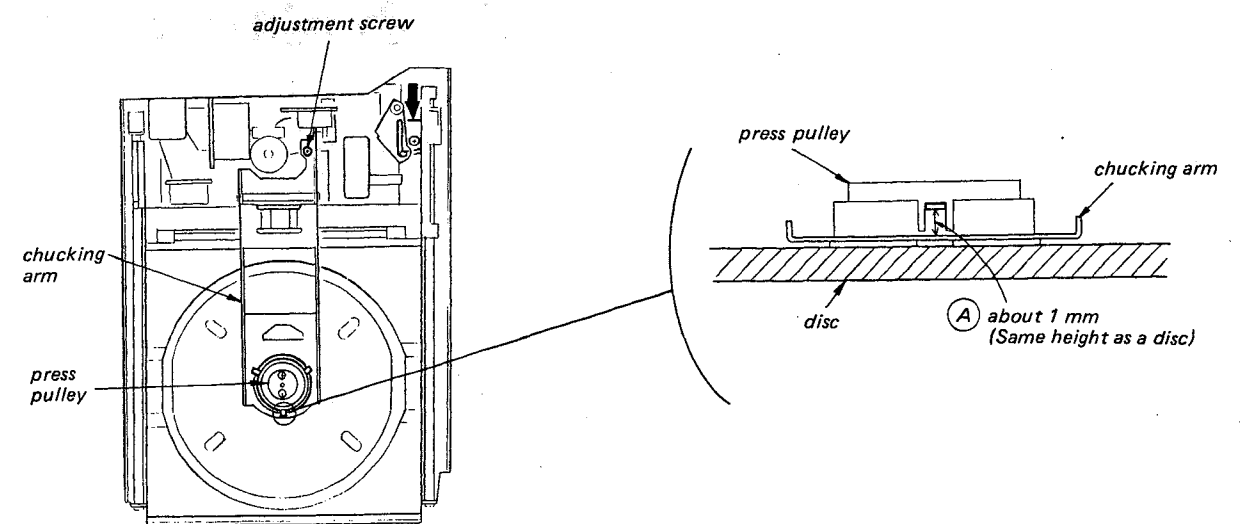

Disc Pulley Height Adjustment

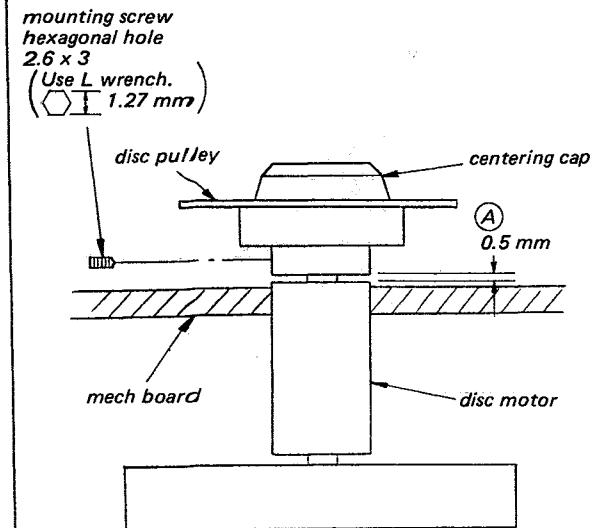

Install the disc pulley so that clearance (A) is 0.5 mm.
Confirm that centering cap moves up and down.

4-2. ELECTRICAL ADJUSTMENTS

1. Perform adjustments in the order given.
2. Use YEDS-1 disc unless otherwise indicated.
3. Use the oscilloscope with more than 10MΩ impedance.

Adjustment Mode

1. Connect main amp board test point ADJ and GND. This is to prevent the disc table from opening even though pits are not read, by making micro-computer IC303 pin (4) low.
2. Turn POWER switch on. (To reset microcomputer.)

After adjustment, remove the lead wire connecting test points ADJ and GND.

Adjustment Location: main board.

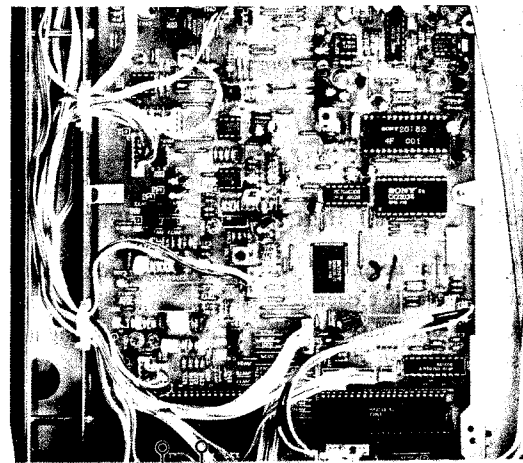

ADJ GND

Connect test points ADJ and GND.

RF PLL Adjustment

Procedure:

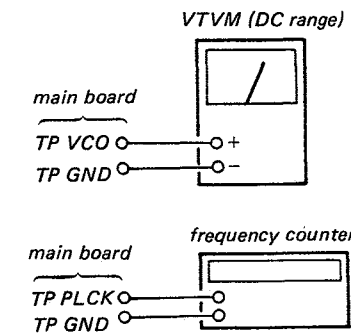

1. Turn POWER switch ON. (stop mode).
2. Keep disc table opened.
3. Put set into adjustment mode (See page 37.)
4. Connect VTVM to main board test points TP VCO and TP GND.
5. Adjust main board RV301 so that reading on VTVM is 0V ± 50 mV.
6. Connect the frequency counter to main board test points TP PLCK and TP GND.
7. Adjust main board L301 so that reading on frequency counter is 4.2818 MHz ± 10 KHz.
8. Reconnect lead wires connected in adjustment mode.
9. Put disc (YEDS-1) in and press ▷ PLAY button.
10. Confirm that reading on frequency counter is 4.3218 MHz.

Adjustment Location: main board.

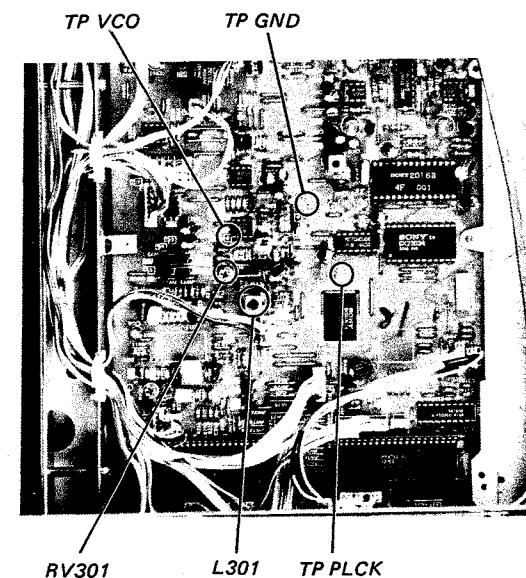

CLV Phase Lock Check

Perform this check when replacing BU-1 (base unit) and press pulley in chucking arm section.)

Procedure:

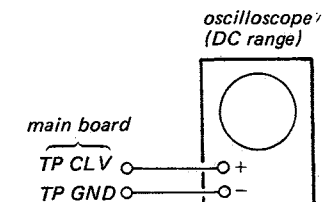

1. Put disc (YEDS-1) in.
2. Connect oscilloscope to main board test points TP CLV and TP GND.
3. Press ▷ PLAY button in TRACK 1 mode.
4. Confirm that the waveform is as shown in the figure below.

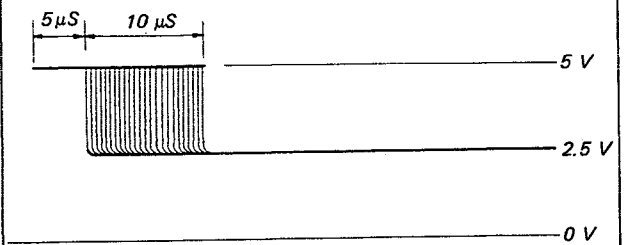

Adjustment Location: main board.

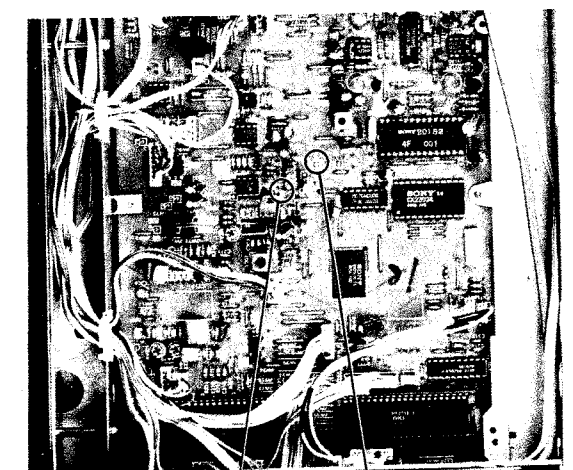

TP CLV

TP GND

REFERENCE

Focus/Tracking Gain Adjustment

A frequency response analyzer is necessary in order to perform this adjustment exactly.

However, this gain has a margin, so even if it is slightly off, there is no problem. Therefore, do not perform this adjustment.

Focus/tracking gain determines the pick-up follow-up (vertical and horizontal) relative to mechanical noise and mechanical shock when the 2-axis device operate.

However, as these reciprocate, the adjustment is at the point where both are satisfied.

- When gain is raised, the noise when the 2-axis device operates increases.
- When gain is lowered, it is more susceptible to mechanical shock and skipping occurs more easily.
- When gain adjustment is off, the symptoms below appear.

Symptoms	Gain	Focus	Tracking
● The time until music starts becomes longer for STOP →▷PLAY or automatic selection (◀▶▶▶ buttons pressed. (Normally takes about 2 seconds.)		low	low or high
● Music does not start and disc continues to rotate for STOP →▷PLAY or automatic selection (◀▶▶▶ buttons pressed.)		-	low
● Disc table opens shortly after STOP →▷PLAY.		low or high	-
● Sound is interrupted during PLAY. Or time counter display stops progressing.		-	low
● More poise during 2-axis device operation.		high	high

The following is a simple adjustment method.

- Simple Adjustment -

Note: Since exact adjustment cannot be performed, remember the positions of the controls before performing the adjustment. If the positions after the simple adjustment are only a little different, return the controls to the original position.

Procedure:

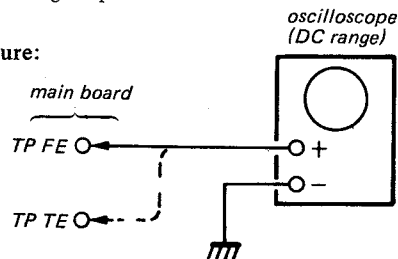

1. Keep the set horizontal. (If the set is not horizontal, this adjustment cannot be performed due to the gravity against the 2 axis device.)
2. Put set in adjustment mode. (see page 37)
3. Insert disc (YEDS-1) and press ▷PLAY button.
4. Connect oscilloscope to main amp board TP FE.
5. Adjustment RV201 so that the waveform is as shown in the figure below. (focus gain adjustment)

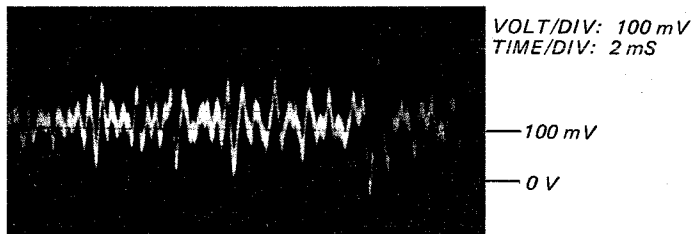

- Inccornt Examples (DC level changes more than on adjusted waveform)

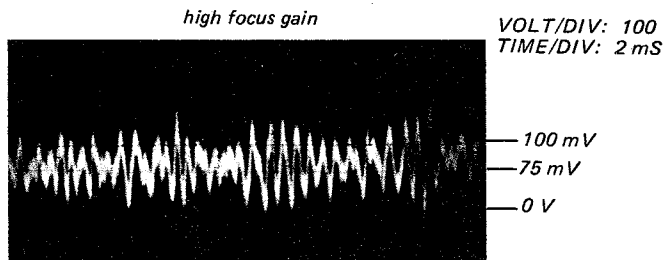
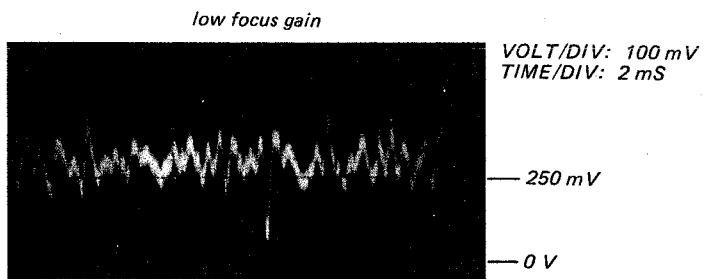

6. Connect oscilloscope to main board TP TE.

7. Adjust RV202 so that the waveform is as shown in the figure below. (tracking gain adjustment)

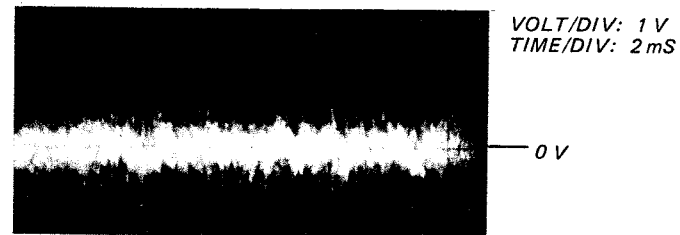

- Incorrect Examples (fundamental wave appears)

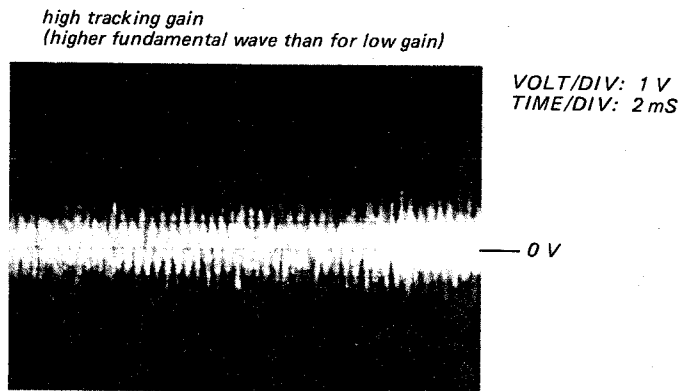
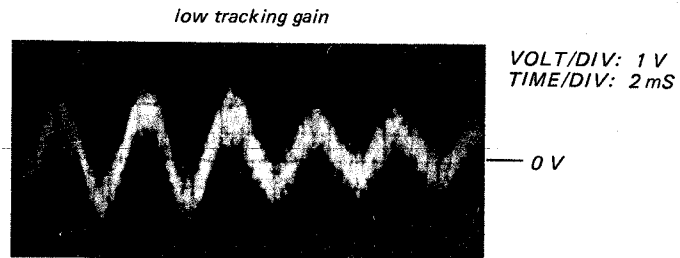

Adjustment Location: main board

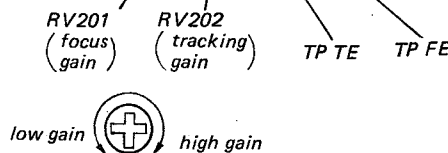
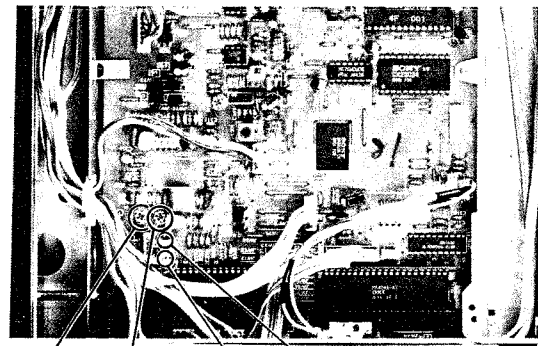

● Semiconductor Lead Layouts

2SD774-5
2SB734-2



10DF2
10E-2
HZ5CLL
RD2.7E-L1
RD5.1E-B1
RD8.2E-B2
RD33E-B3

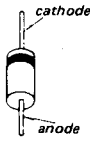

CX20108

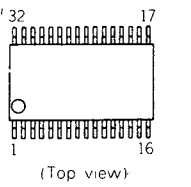

2SB740
2SC2001



MSM6404A-39RS
MSM6404A-41RS

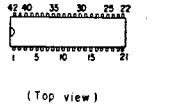

2SA1175
2SC2785-E

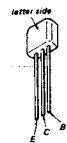

1SS119

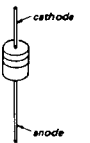

M50760-414P

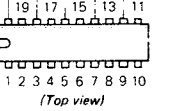

DTA114ES
DTC114ES
DTC144ES
DTC143TS



KV1236Z

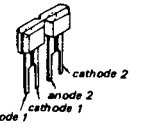

CX20197
NJM4558D-FA
TDB0353DP
μPC4082C
μPC4558C

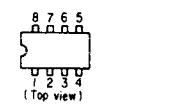

2SK152

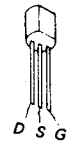

GL-5NG27

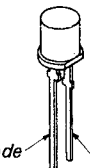

MB84066B
TC74HCU04P

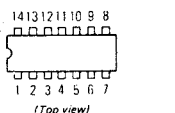

2SA874
DTC143TF



PH302B

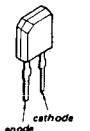

CX23035

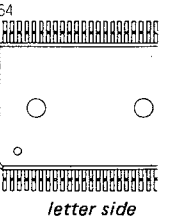

THS103A-1

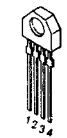

21DQ05

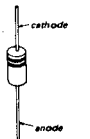

MB8416-20LPF

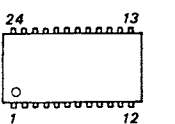

SECTION 5
5-1. MOUNTING DIAGRAM
DIAGRAMS — BU-1 (BASE UNIT) Section —

1 2 3 4 5 6 7 8 9

● Semiconductor Lead Layouts

2SD774-5
2SB734-2



10DF2
10E-2
HZ5CLL
RD2.7E-L1
RD5.1E-B1
RD8.2E-B2
RD33E-B3

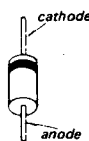

CX20108

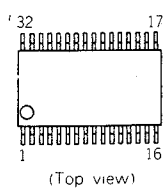

CX23034

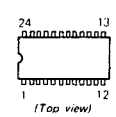

NJM79M12A

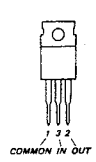

2SB740
2SC2001

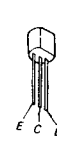

1SS119

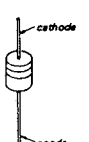

MSM6404A-39RS
MSM6404A-41RS

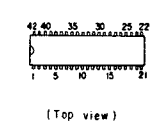

CX20152

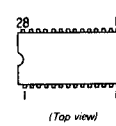

NJM78M05A

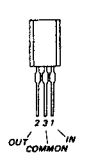

2SA1175
2SC2785-E

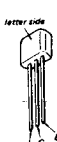

KV1236Z

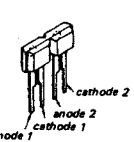

M50760-414P

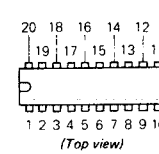

μPD4053BC

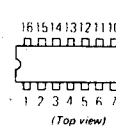

NJM79M05A

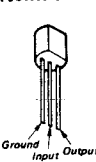

DTA114ES
DTC114ES
DTC144ES
DTC143TS

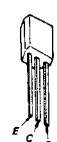

GL-5NG27

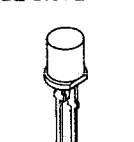

CX20197
NJM4558D-FA
TDB0353DP
μPC4082C
μPC4558C

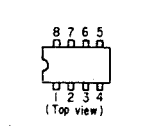

M54940P

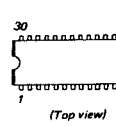

NJM4560S

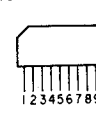

2SK152



anode cathode

MB84066B
TC74HCU04P

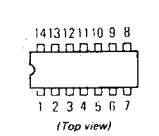

NJM7805A

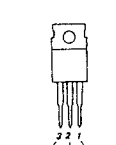

2SA874
DTC143TF



PH302B

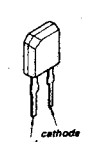

CX23035

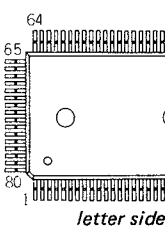

NJM7905A

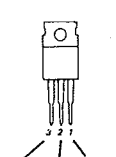

THS103A-1



21DQ05

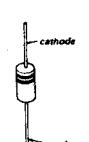

MB8416-20LPF

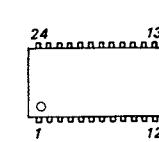

μPC78M12H

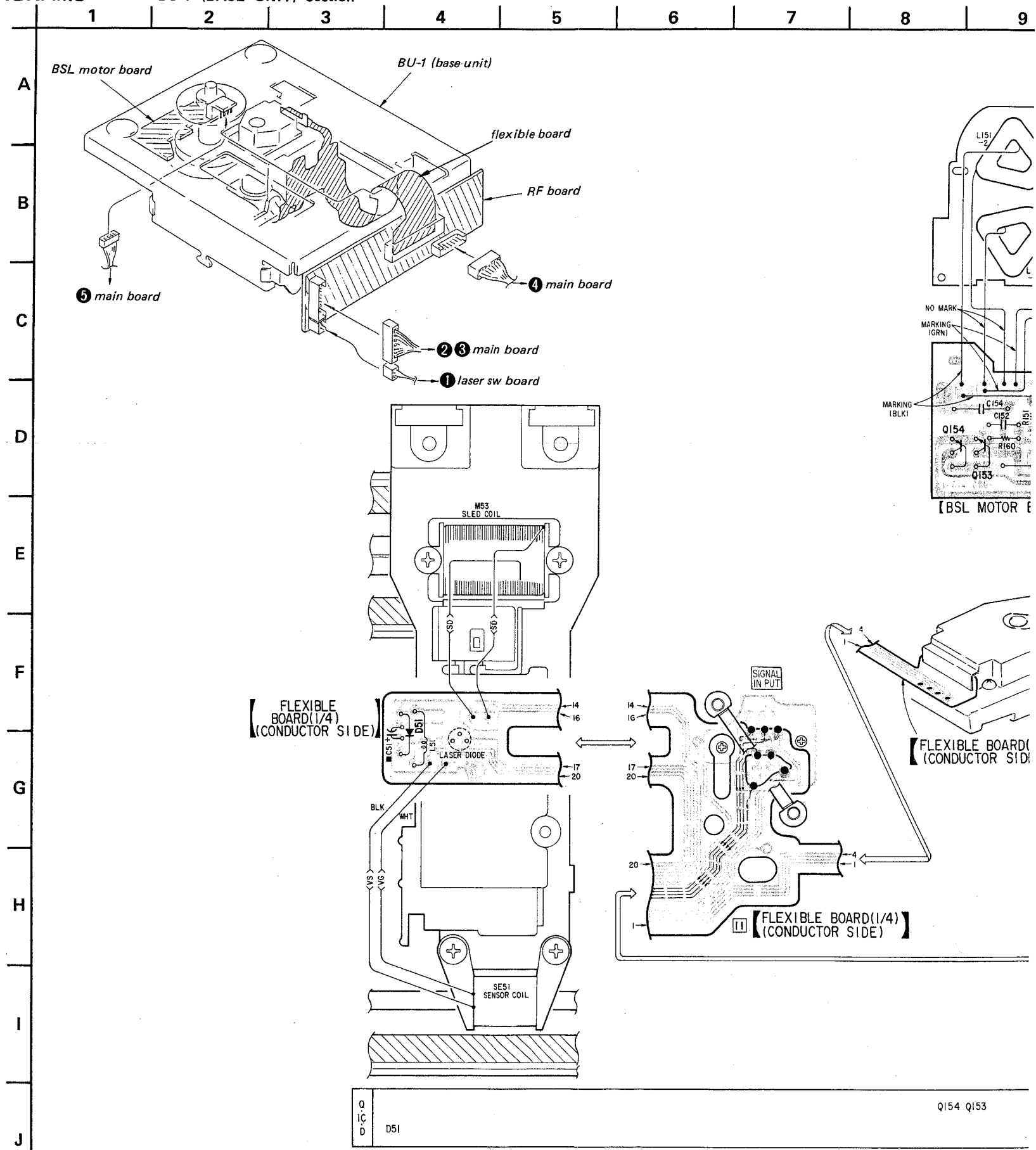
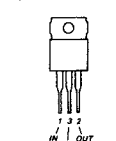

n in
OLT/DIV: 1 V
ME/DIV: 2 mS
0 V
OLT/DIV: 1 V
ME/DIV: 2 mS
0 V
OLT/DIV: 1 V
ME/DIV: 2 mS
0 V

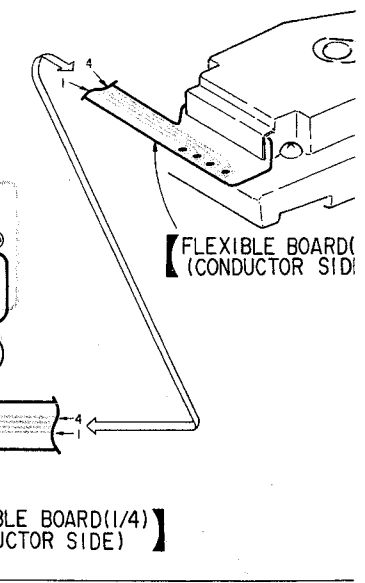
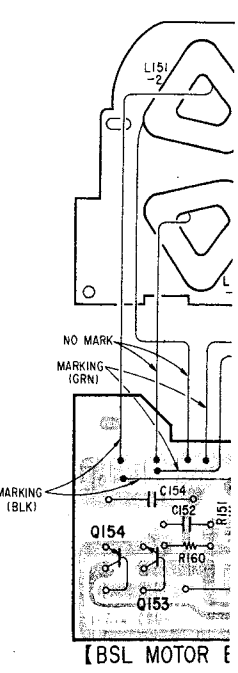

Q IC D D51 Q154 Q153

1 2 3 4 5 6 7 8 9 10 11 12 13 14 15 16

IM12A
3.2 IN OUT
BM05A
1.0 IN IN
9M05A
1.0 IN IN
I560S
456789

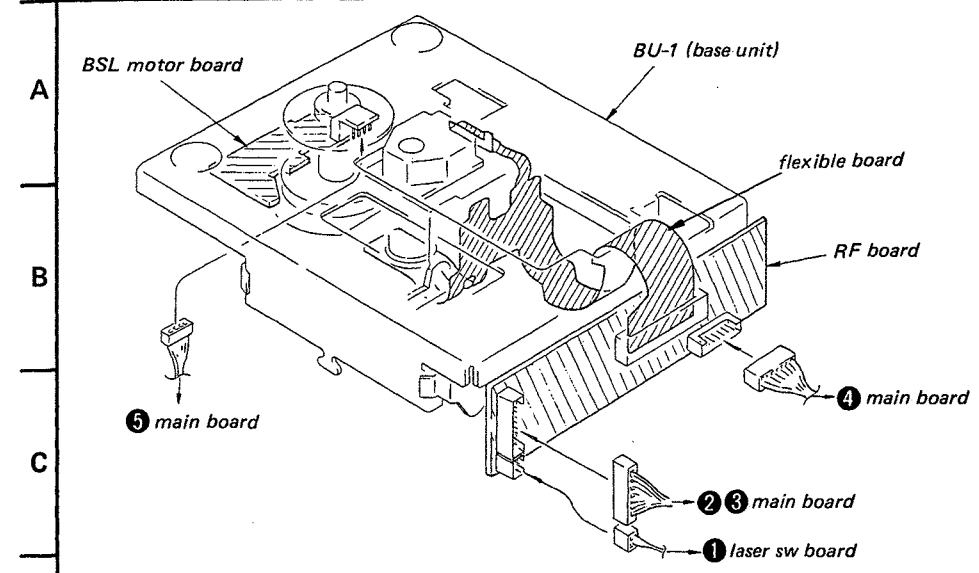

Note:
 ● — : parts extracted from the conductor side.
 ● ■ : part mounted on the conductor side.
 — : signal path
 ● : B + pattern

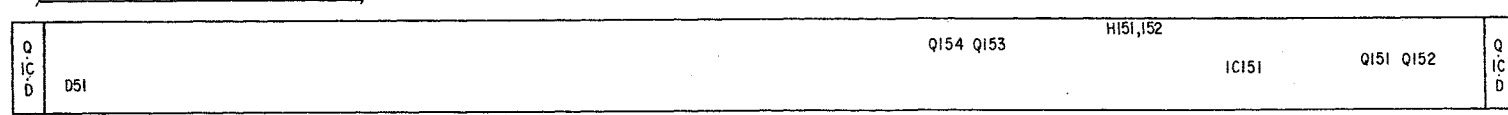
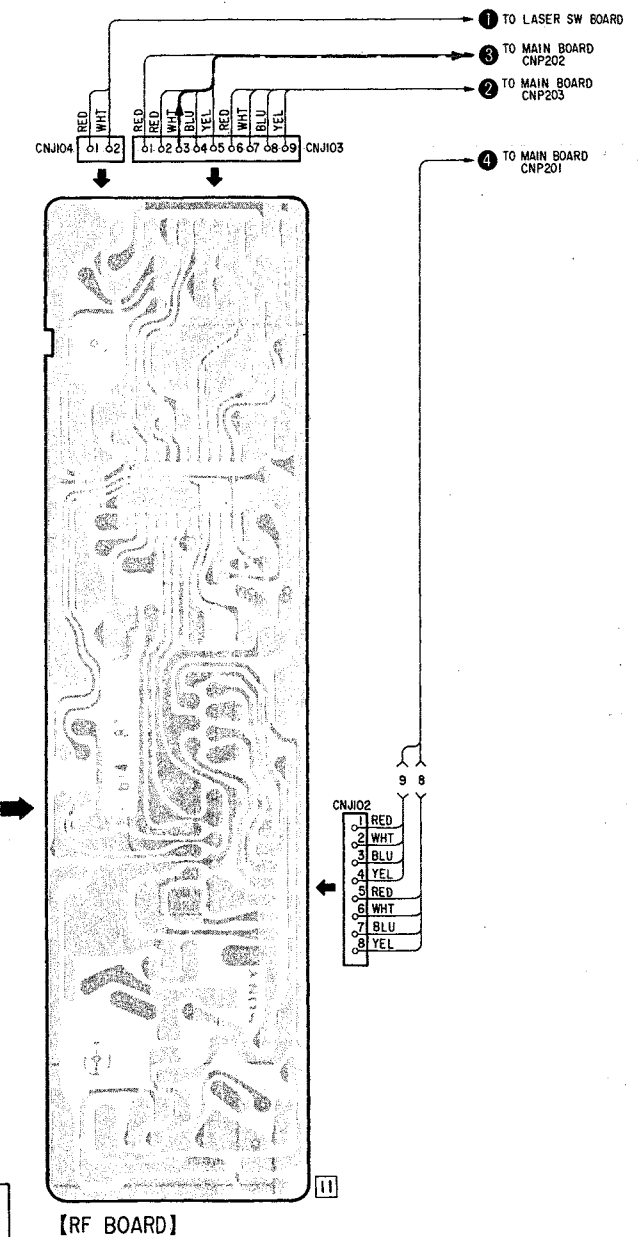
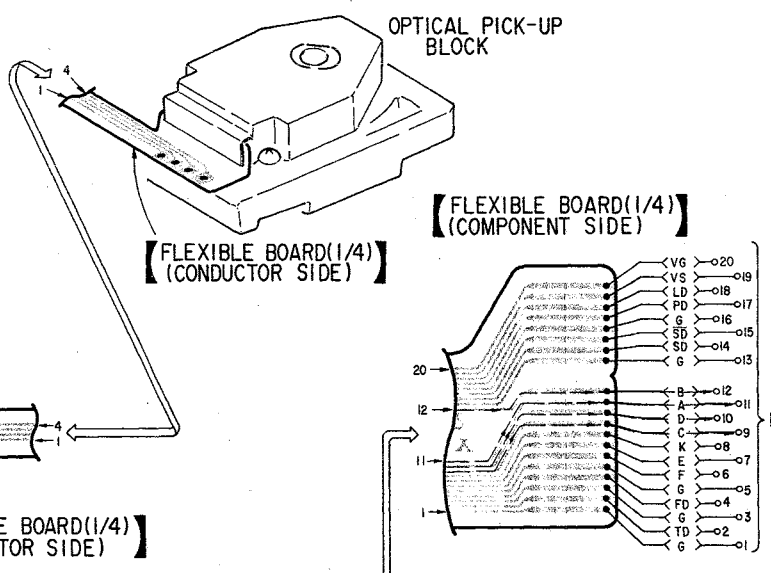
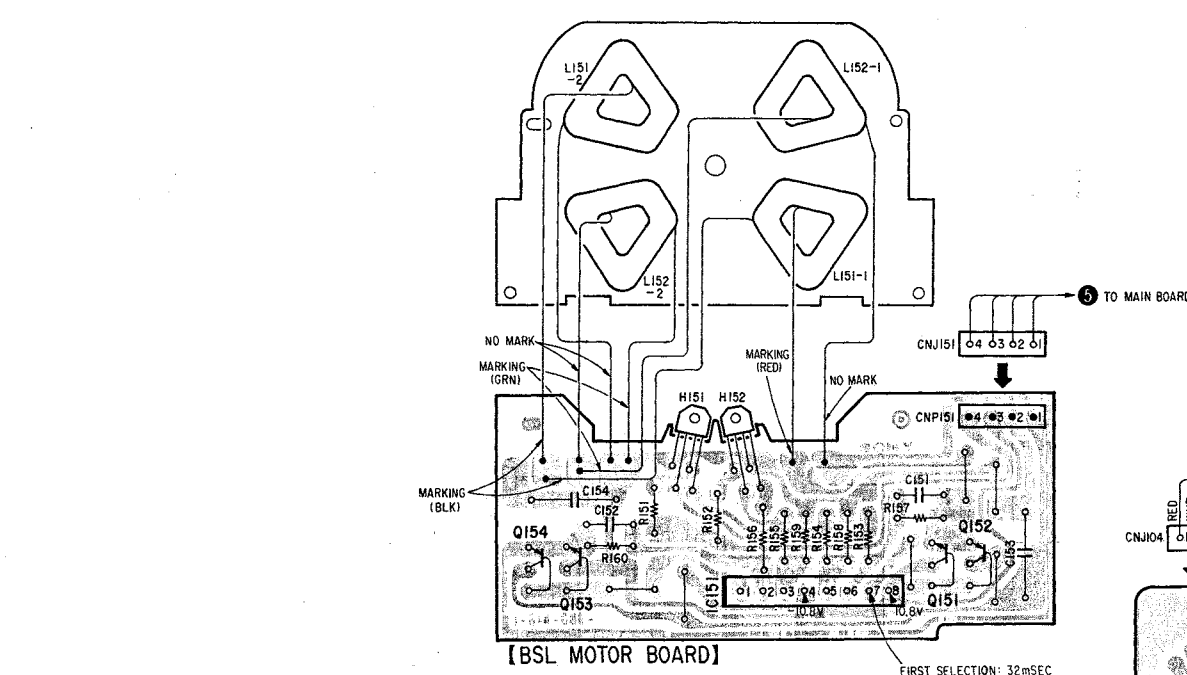
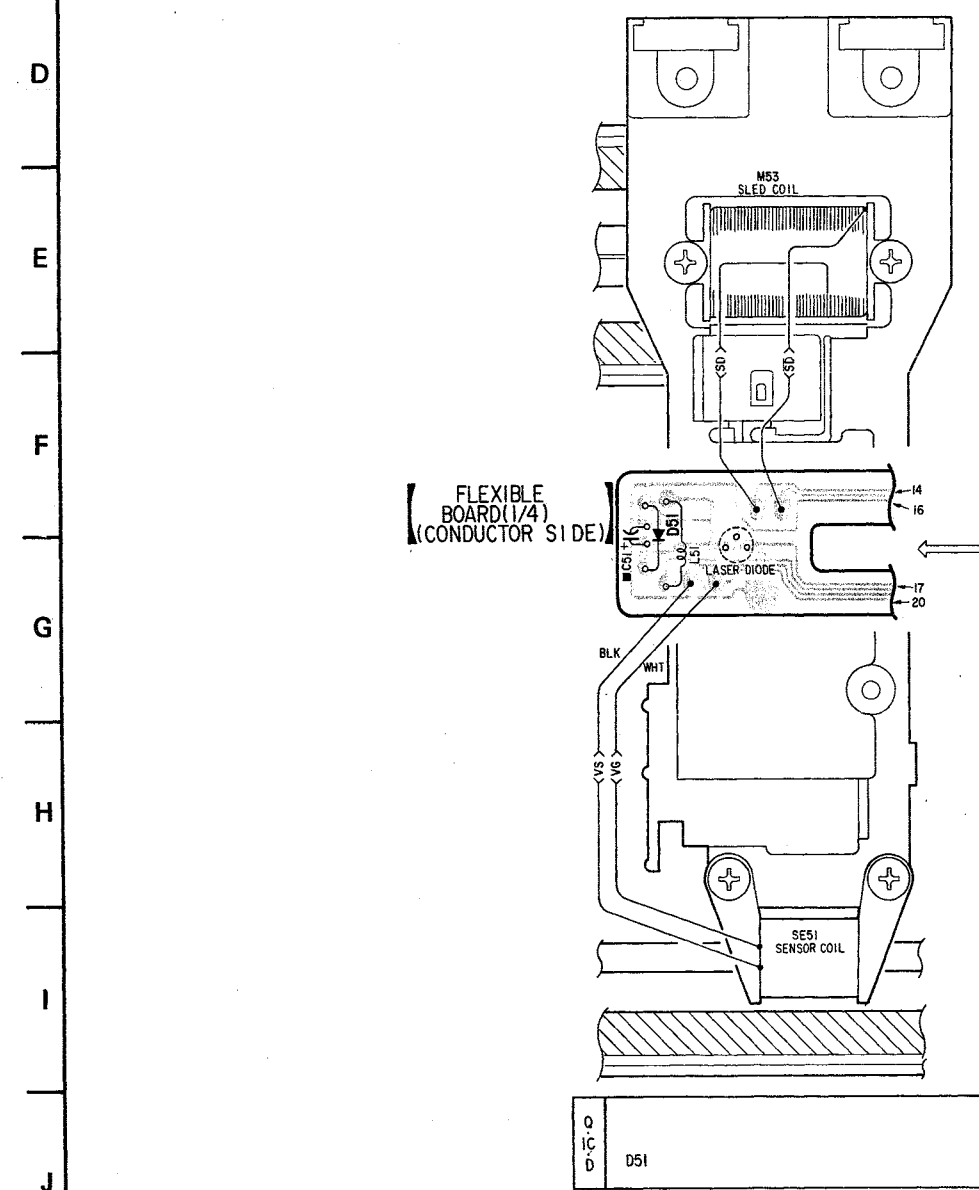

A
B
C
D
E
F
G
H
I
J

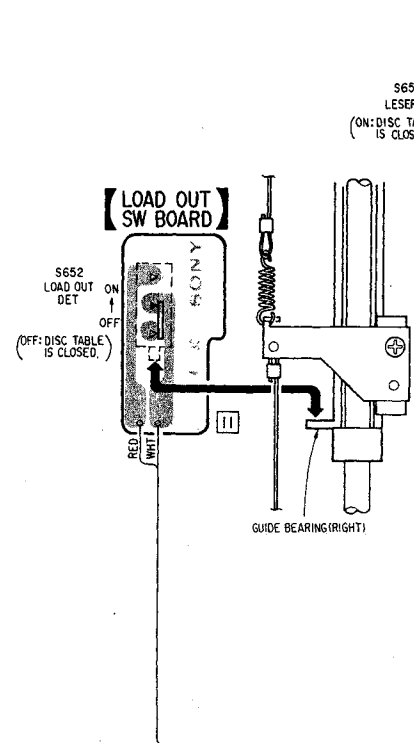

[LOAD IN SW BOARD]

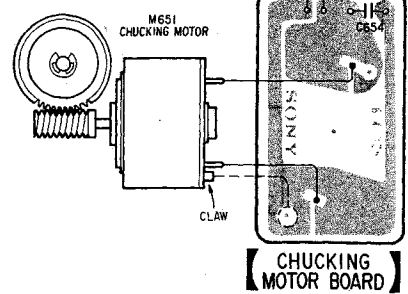
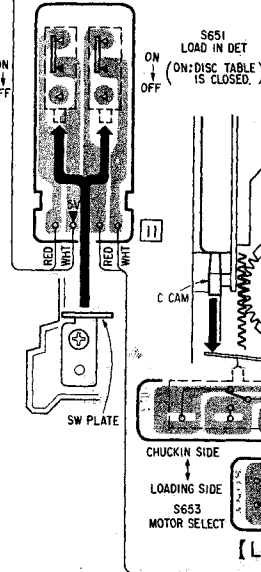

[CHUCKING SW BOARD]

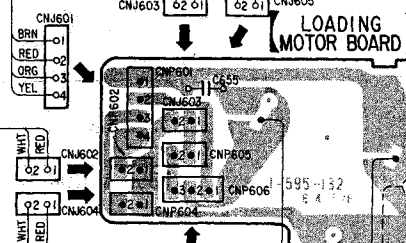
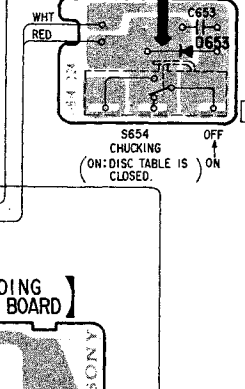

[L.C SW BOARD]

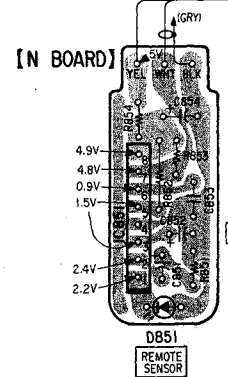
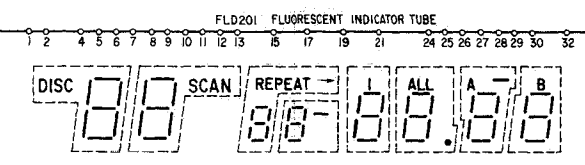
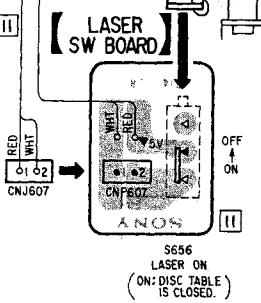
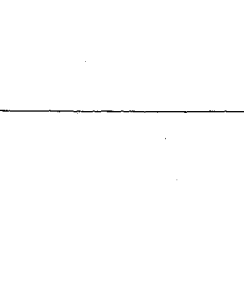

[DISPLAY BOARD]

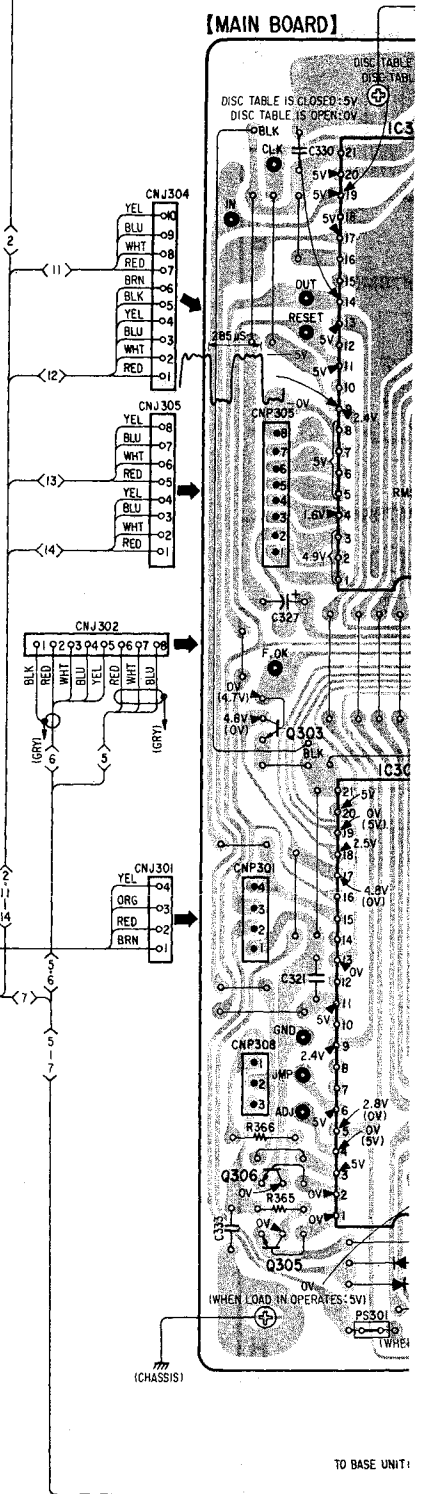
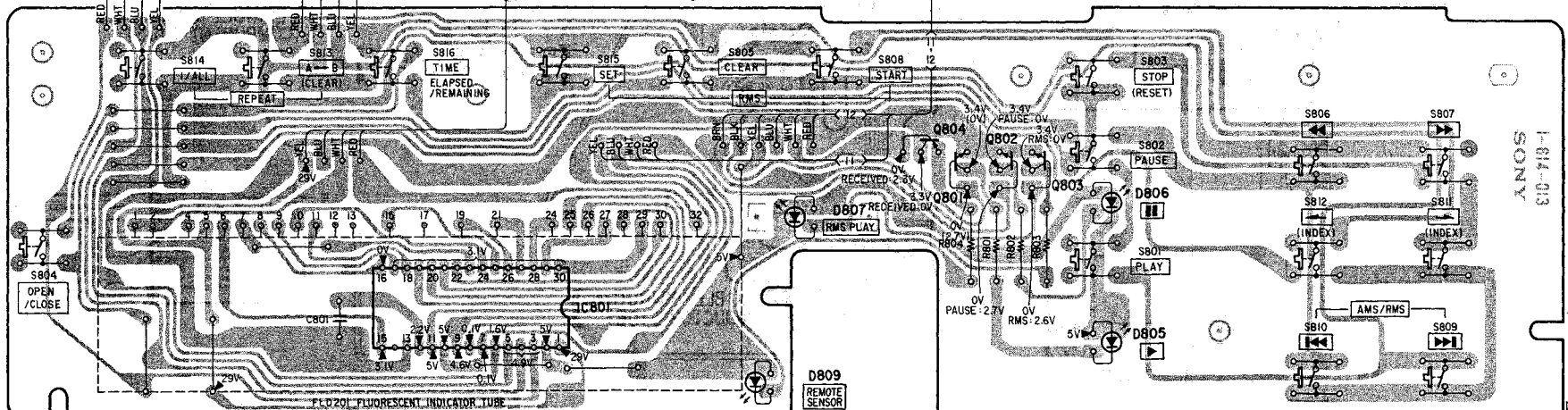

IC				154	153		IC151		151	152		IC30
Q	IC851											303
							804	801	802	803		306
D		652										305
		651										IC30
	851											211
												201

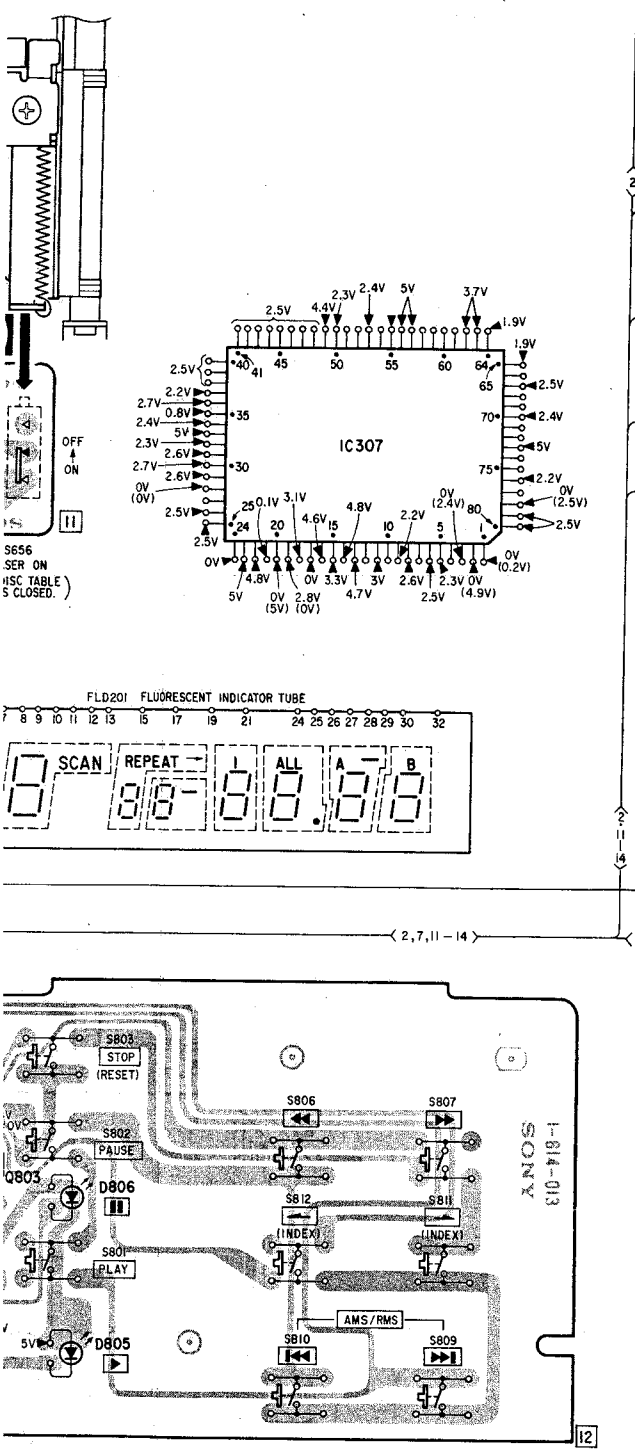

[MAIN BOARD]

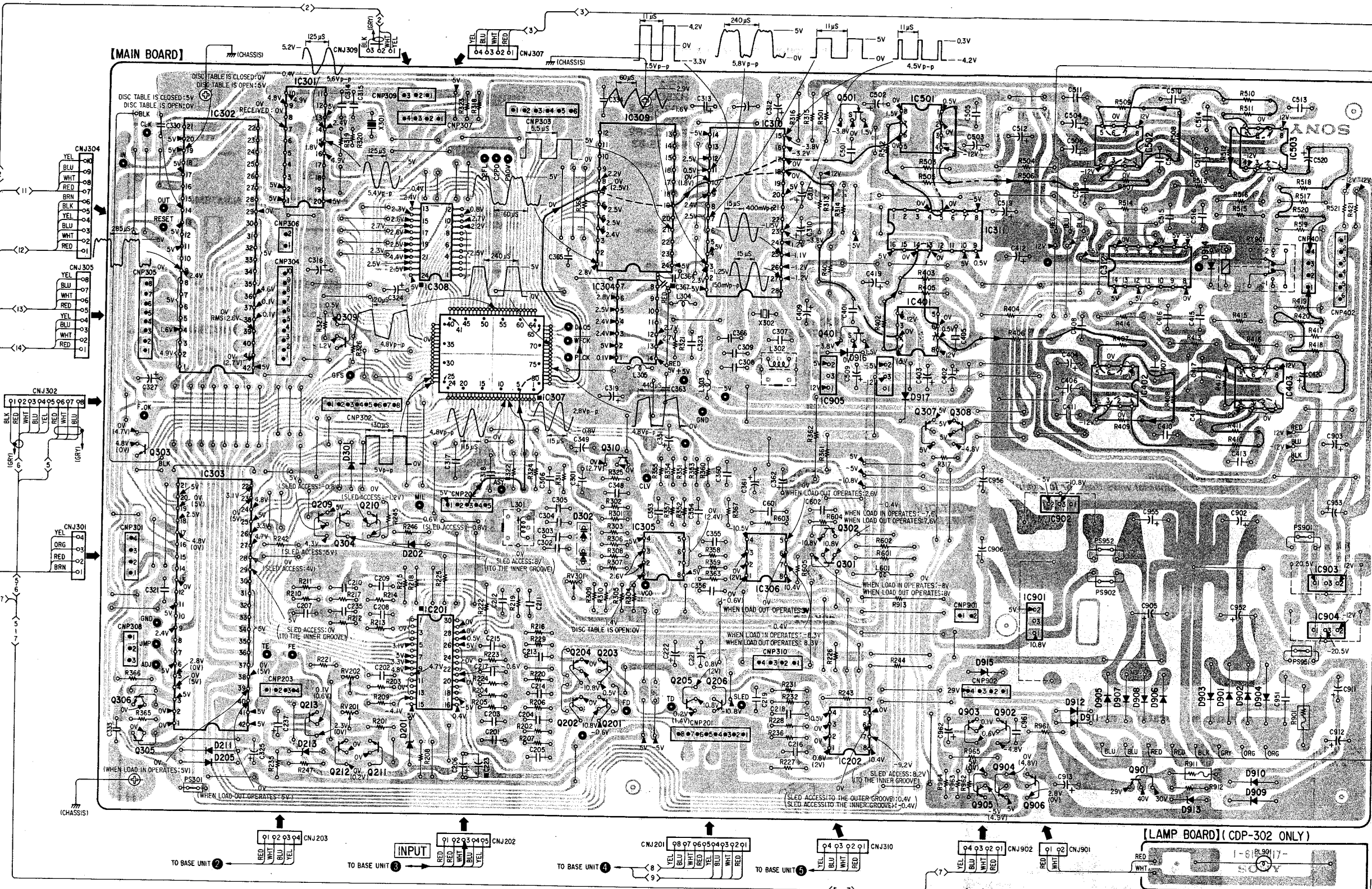

[LAMP BOARD] (CDP-302 ONLY)

154 153	IC151	151 152	IC302	IC301	IC308	IC307	IC309 IC304	IC310	501 401	IC501 IC311 IC401	307 308	IC502 IC312	IC503	
			303	309	209 304 210		310		IC905	IC906		IC402	IC403	
			306 IC303	213 212 211	IC201		204 203 201	IC305	301 IC202			903 902 905 904 906	901	IC903 IC904
				301	202				916	917				
			211 205	213	201		302					915		914
												912 905 907 908 906	903 901 902 904	910 909
												911	913	

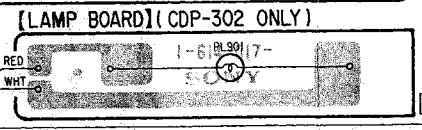
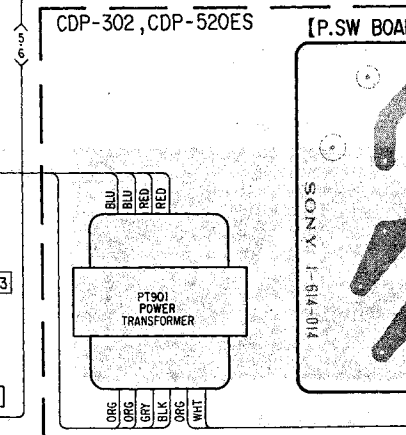
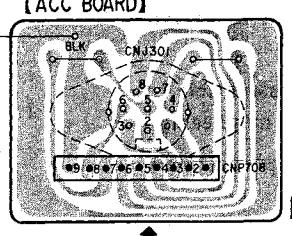
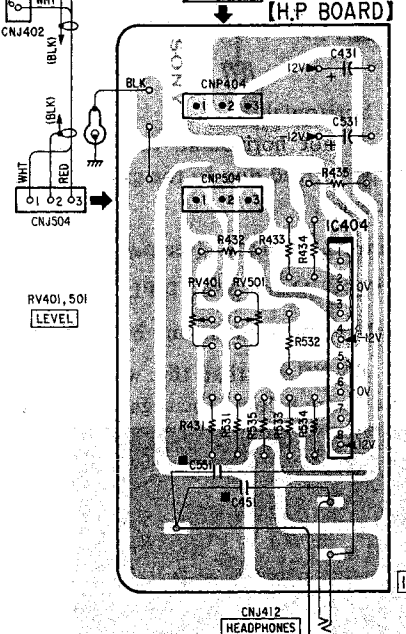
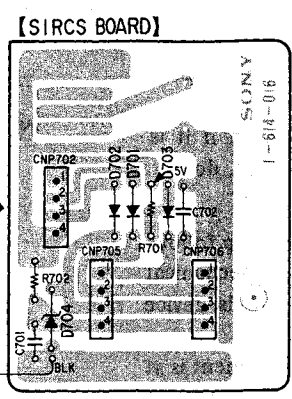
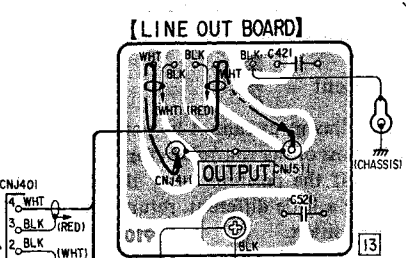
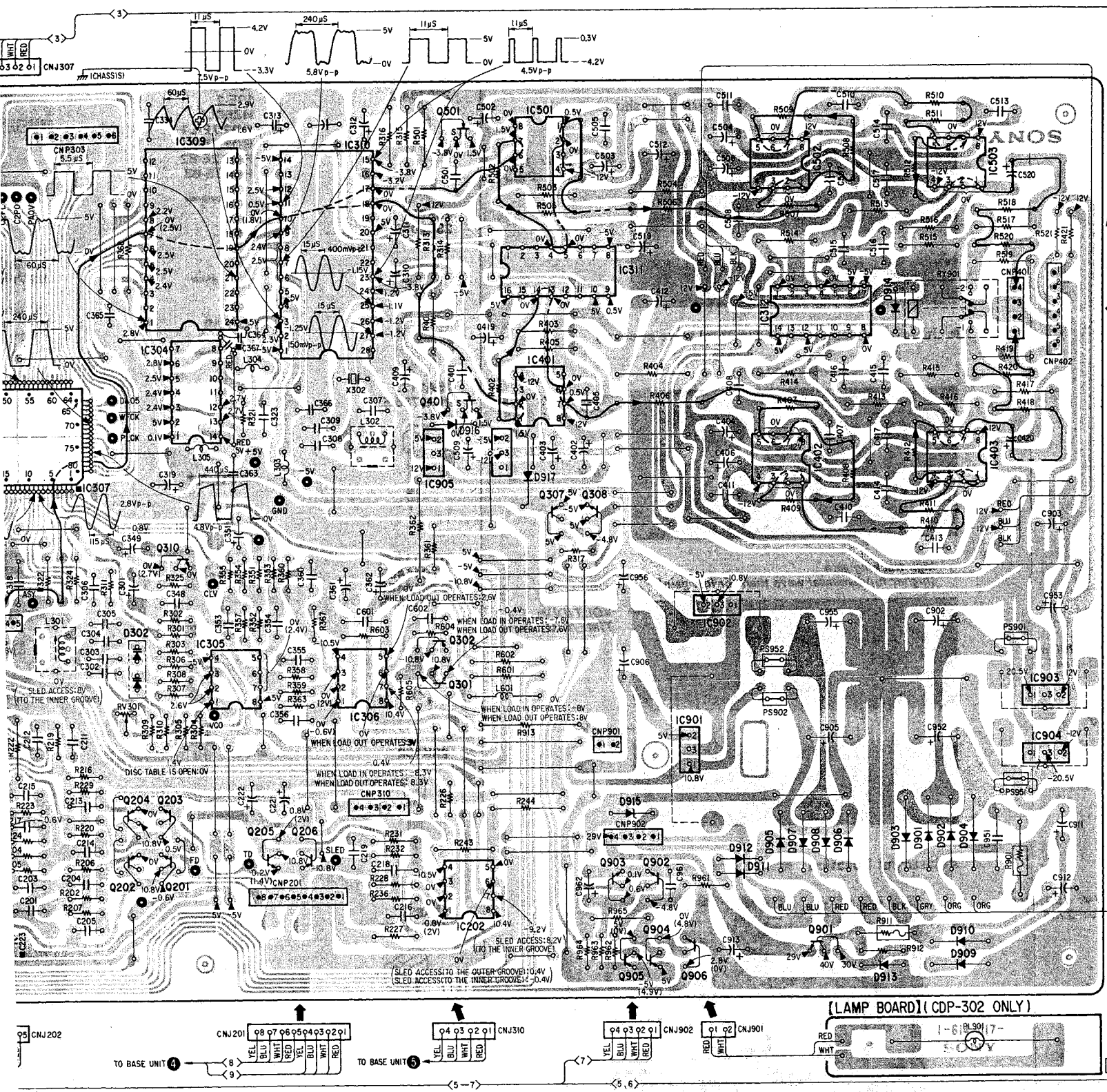

IC 307	IC 309 IC 304	IC 310	501	IC 501 IC 311 IC 401	IC 502	IC 312	IC 503	IC 404	IC 903 IC 904
	310 IC 305	IC 306	401	IC 905 IC 906 307 308	IC 402				
	204 203 202 201	205 206	302 301	IC 202	IC 901 IC 902	903 902 905 904 906	901		
			916	917			914		702 701 703 704
302					915	912 905 907 908 906 911	903 901 902 904 910 909		
						913			

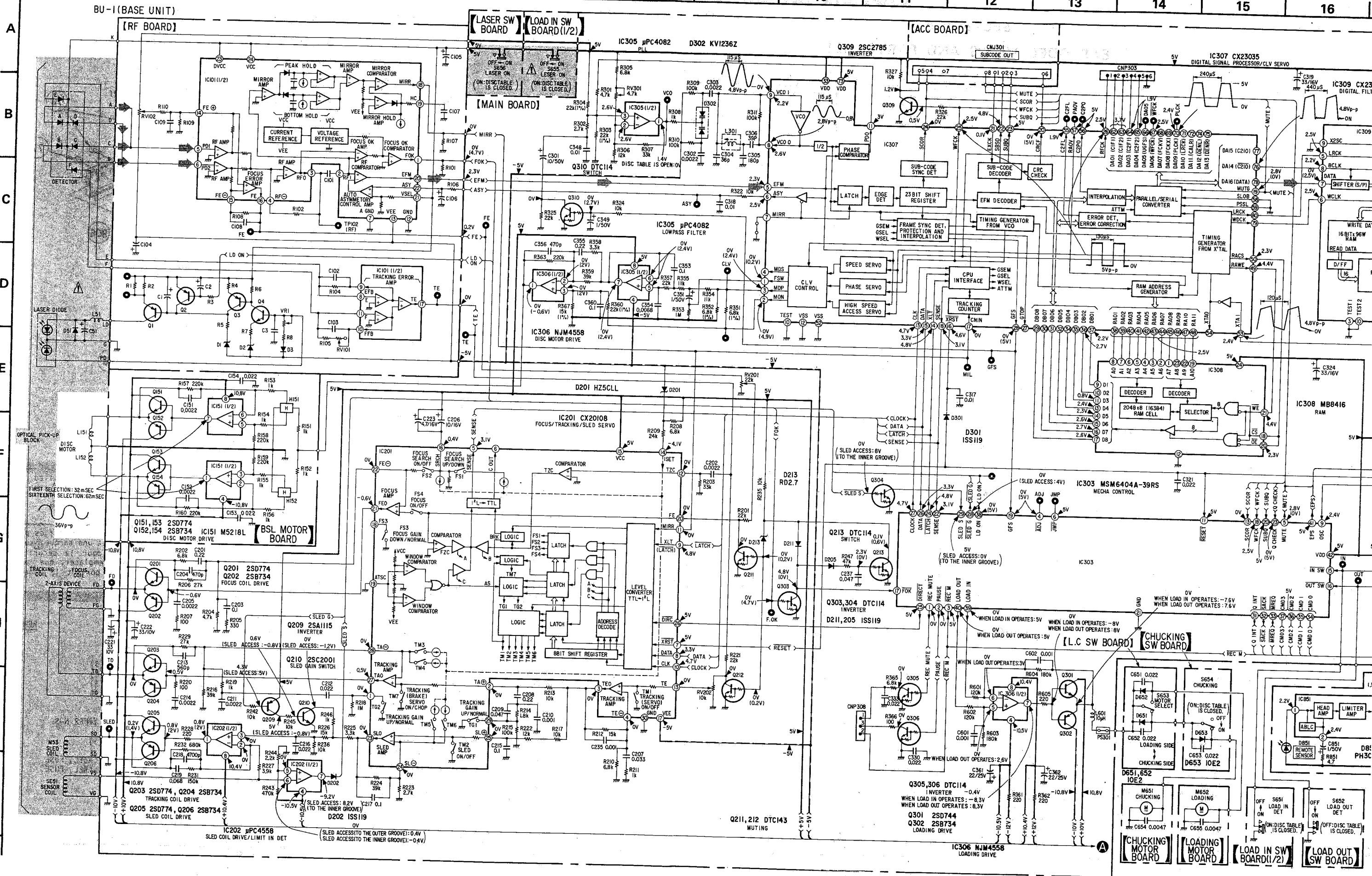

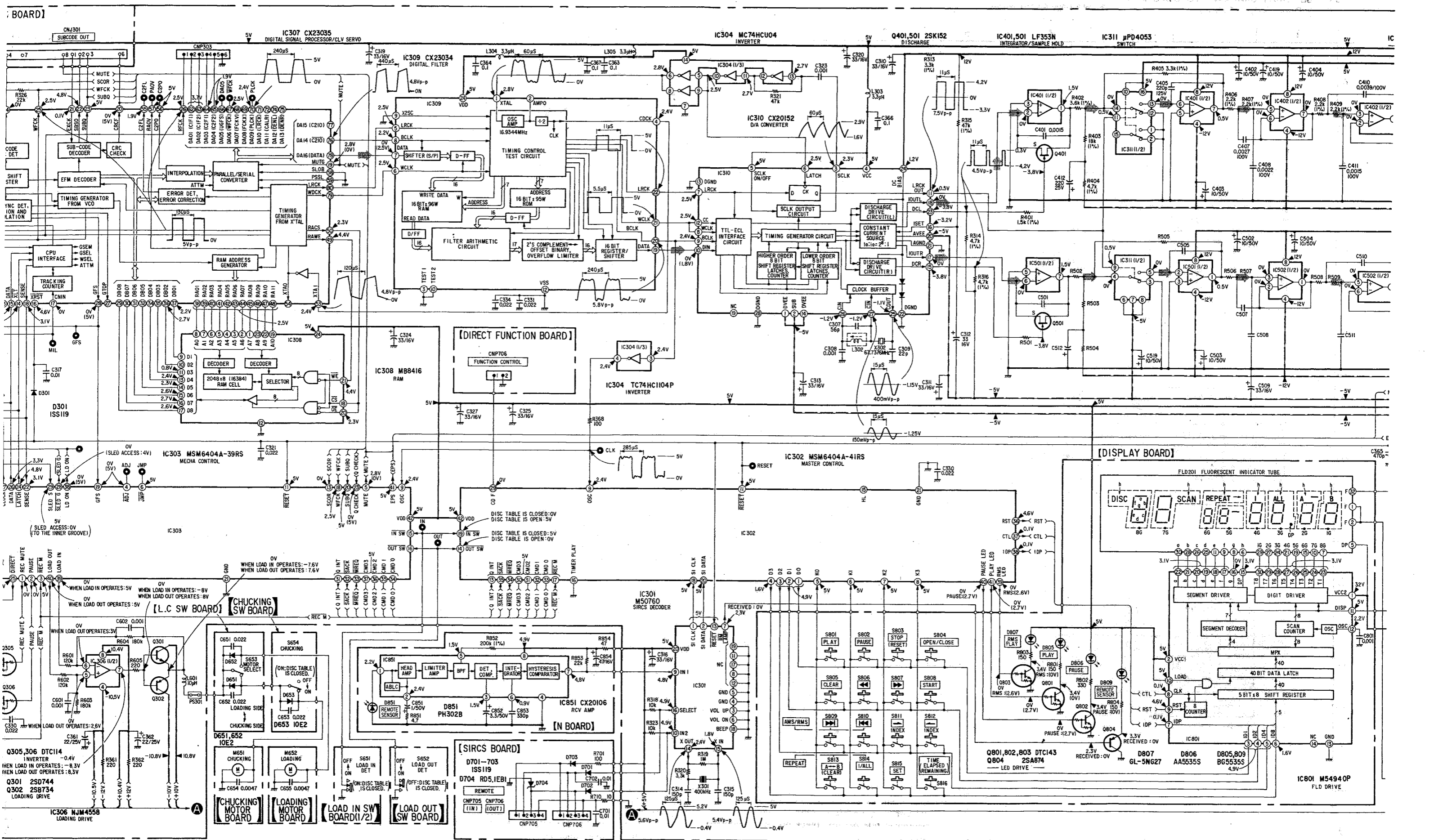

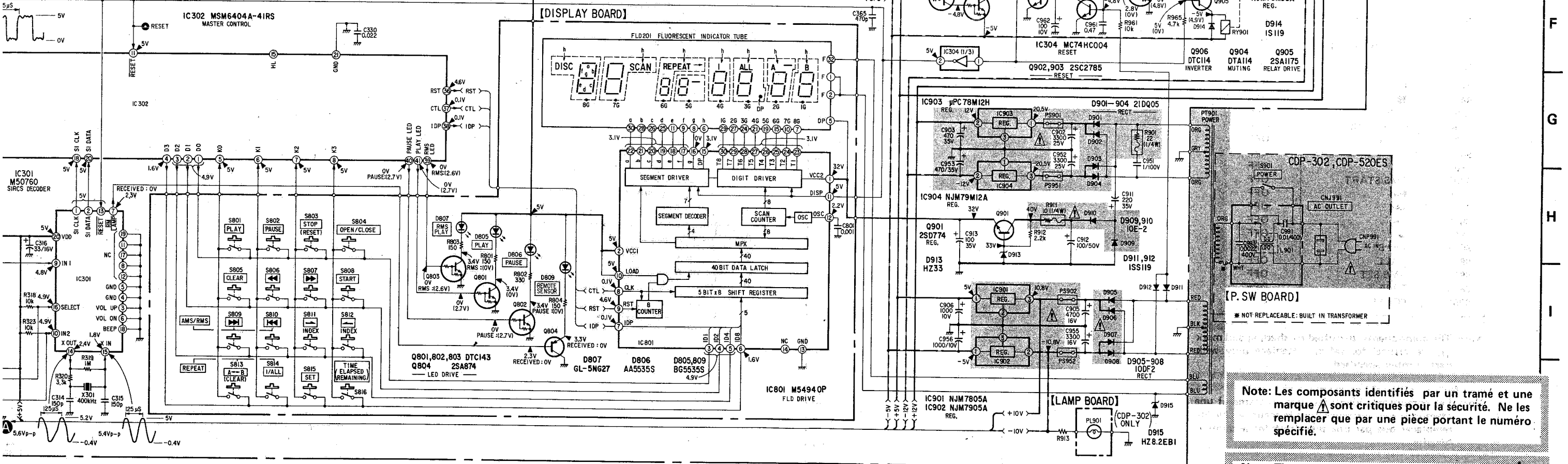
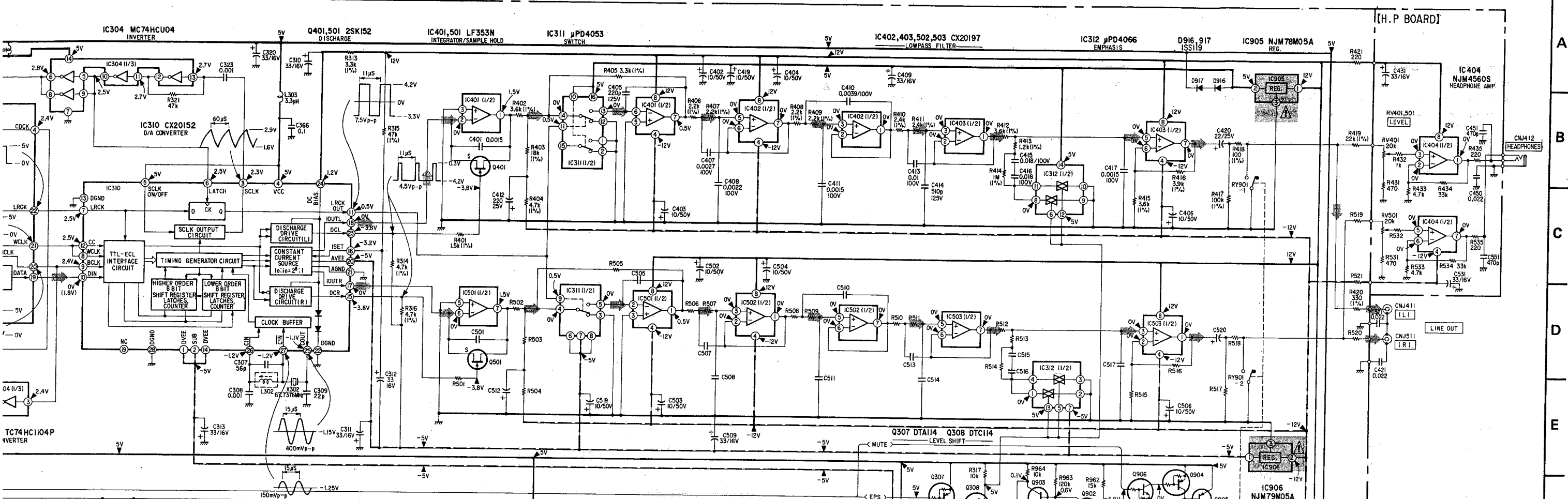





Note: Les composants identifiés par un trame et une marque sont critiques pour la sécurité. Ne les remplacer que par une pièce portant le numéro spécifié.







Note: The components identified by shading and mark are critical for safety. Replace only with part number specified.

Note on Schematic Diagram:

Note:

- All capacitors are in μF unless otherwise noted. pF : $\mu\mu\text{F}$ 50 WV or less are not indicated except for electrolytics and tantalums.
- All resistors are in Ω and $1/4\text{W}$ or less unless otherwise specified.
-  : signal path.
- Components for right channel have same values as for left channel.
-  : nonflammable resistor.
-  : B+ bus.
-  : B- bus.
- Voltages are dc with respect to ground unless otherwise noted.
- Readings are taken under no-signal conditions with a VOM (50 $\text{k}\Omega/\text{V}$), no mark: STOP (): PLAY
- Voltage variations may be noted due to normal production tolerances.
- Waveforms are taken to ground under no-signal conditions by using oscilloscope. Voltage variations may be noted due to normal production tolerances.

Switch

Ref. No.	Switch	Position
S651	LOAD IN DET	ON
S652	LOAD OUT DET	OFF
S653	MOTOR SELECT	CHUCKING SIDE
S654	CHUCKING LASER ON (CHUCKING SIDE)	ON
S655	LASER ON (LOADING SIDE)	ON
S801		OFF
S802		OFF
S803	STOP	OFF
S804	OPEN/CLOSE	OFF
S805	CLEAR	OFF
S806		OFF
S807		OFF
S808	RMS/START	OFF
S809		OFF
S810		OFF
S811		OFF
S812		OFF
S813	A \leftrightarrow B	OFF
S814	I/ALL	OFF
S815	RMS/SET	OFF
S816	TIME	OFF
S991	POWER	OFF

Note: The components identified by shading and mark  are critical for safety. Replace only with part number specified.





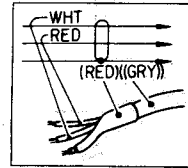

Note: Les composants identifiés par un trame et une marque  sont critiques pour la sécurité. Ne les remplacer que par une pièce portant le numéro spécifié.

Note on Mounting Diagram:

Note:

- Color code of sleeving over the end of the jacket.



-  : parts extracted from the component side.
-  : parts extracted from the conductor side.
-  : indicates side identified with part number.
-  : signal path
-  : L-CH signal path
-  : R-CH signal path
-  : B+ pattern

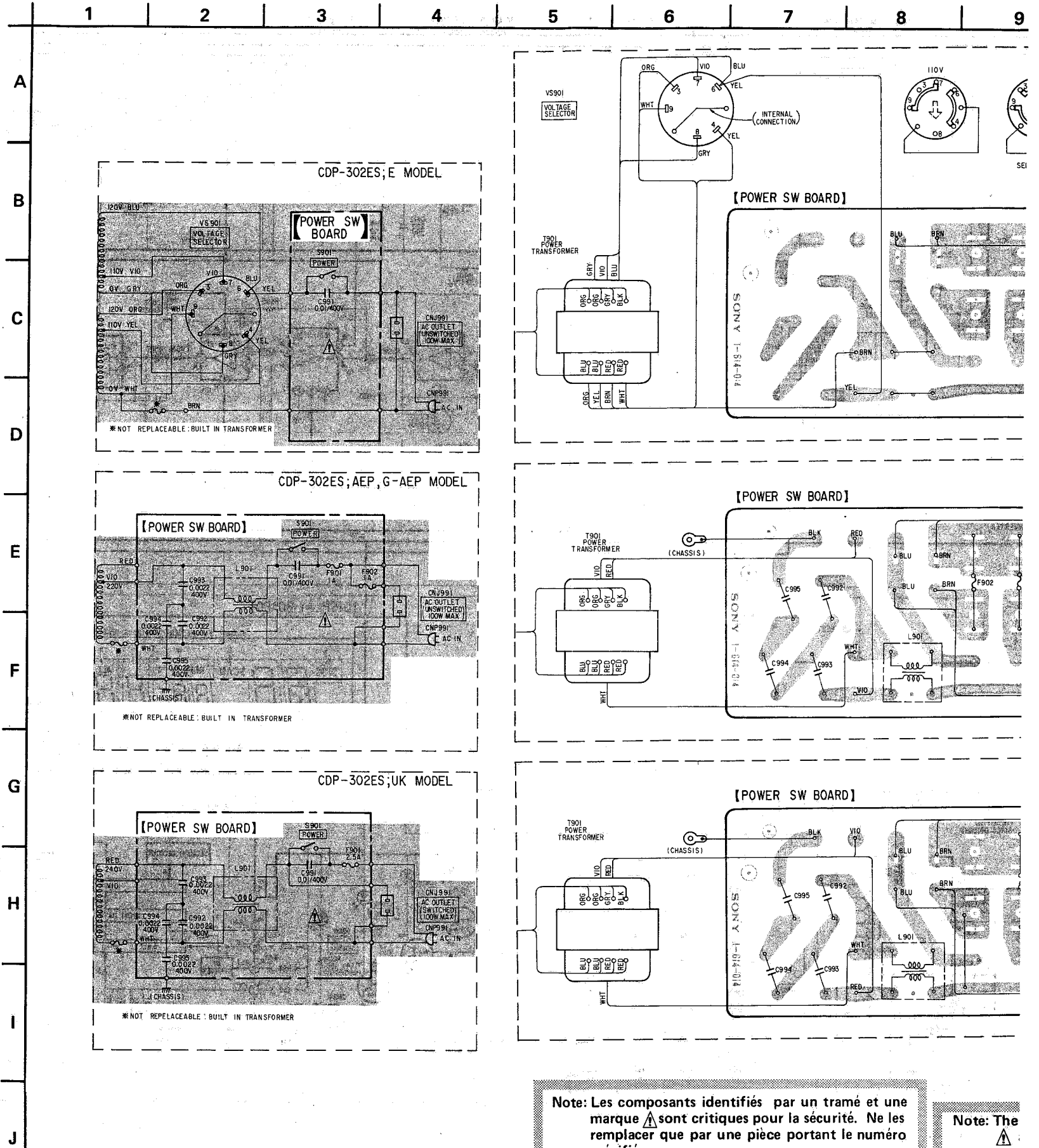



SECTION 6

EXPLODED VIEWS AND PARTS LIST

NOTE:

- The mechanical parts with no reference number in the exploded views are not supplied.
- Items marked "*" are not stocked since they are seldom required for routine service. Some delay should be anticipated when ordering these items.
- The construction parts of an assembled part are indicated with a collation number on the remark column.

The components identified by shading and mark  are critical for safety. Replace only with part number specified.

Les composants identifiés par une trame et une marque  sont critiques pour la sécurité. Ne les remplacer que par une pièce portant le numéro spécifié.

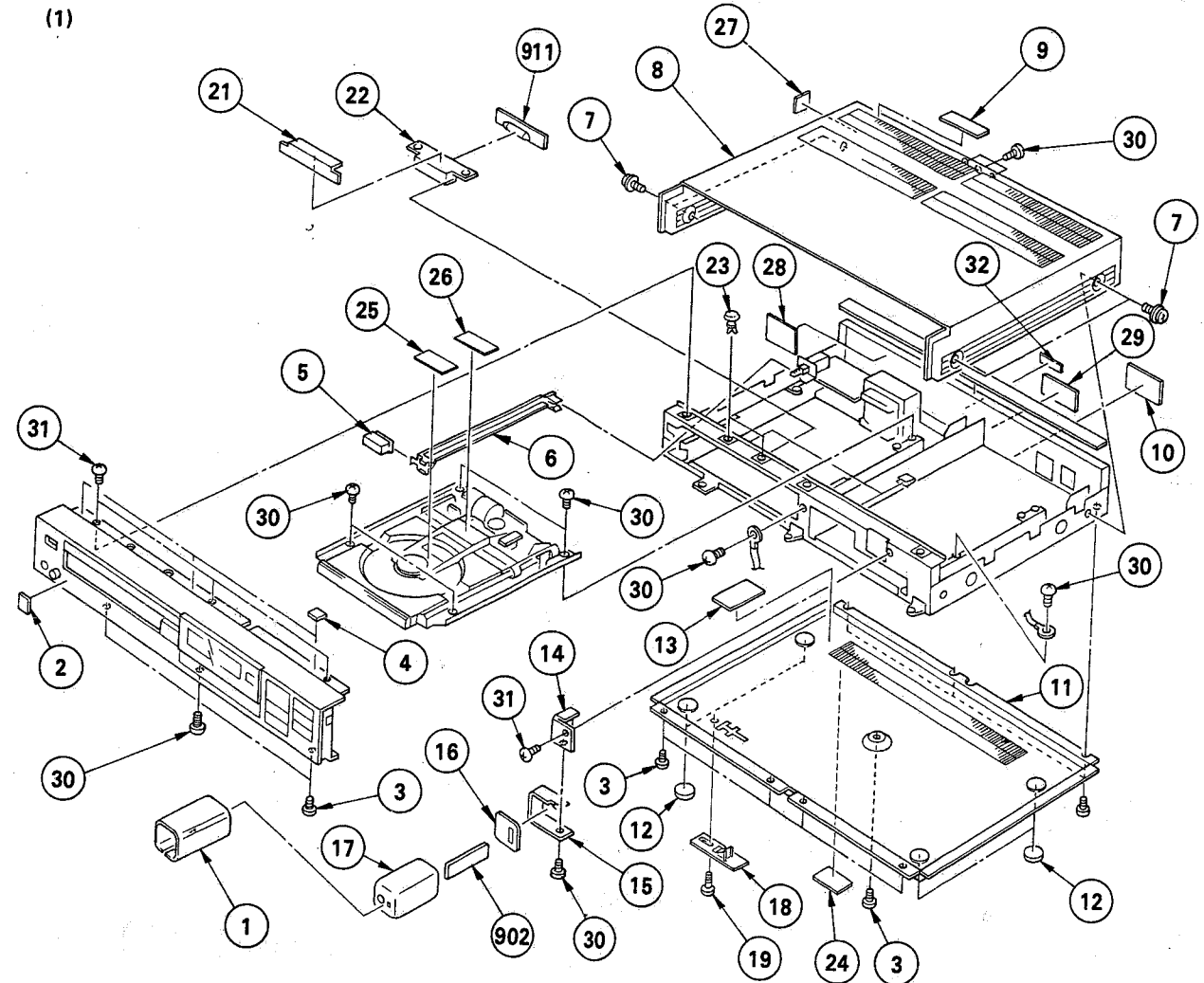

No.	Part No.	Description	REMARKS	No.	Part No.	Description	REMARKS
1	*4-884-637-00	SHEET (C), INSULATING		15	*4-908-408-01	PLATE, FIXED, CATCHER, RAY	
2	3-703-710-41	(302ES,520ES)...STICKER, SONY SYMBOL	(12)	16	*4-342-118-00	LID, SHIELD CASE, R	
3	3-703-685-21	SCREW (+BV 3X8)		17	*4-342-117-00	CASE, SHIELD (MAIN), R	
4	9-911-840-XX	CUSHION		18	*4-908-600-01	LEVER, LOCK, TRANSPORT	
5	3-318-911-11	KNOB (POWER.L.), T MOLD		19	3-323-470-01	SCREW (B3X6), (+ -)	
6	*4-908-425-01	LEVER, POWER SWITCH		20	3-831-441-XX	CUSHION	
7	4-889-321-31	SCREW		21	*4-908-459-01	(302)...PLATE, LIGHT INTERCEPTION	
8	4-908-438-01	CASE		22	*4-908-458-01	(302)...BRACKET, LAMP	
9	4-885-831-00	LABEL, CAUTION		23	4-812-134-00	(302)...RIVET NYLON, 3.5	
10	*4-908-449-01	(302).....LABEL, MODEL NUMBER (U)		24	3-703-079-21	(302ES;UK)...LABEL, CAUTION (BACK)	
	*4-908-450-01	(520ES).....LABEL, MODEL NUMBER (U)		25	*3-703-680-00	(302,520ES)...LABEL, CAUTION, SUB, NEW UL	
	*4-908-453-01	(302ES;AEP)...LABEL, MODEL NUMBER (AE1)		26	4-908-404-01	(302ES)...LABEL, APARTURTE, LASER, DHHS	
	*4-908-455-01	(302ES;UK)...LABEL, MODEL NUMBER (UK)		27	4-908-402-01	(302,520ES)...LABEL, INTERLOCK, DHHS	
	*4-908-457-01	(302ES;E)...LABEL, MODEL NUMBER (E2/3)		28	4-908-401-01	(302,520ES)...LABEL, HOUSING, DHHS	
	*4-908-463-01	(302ES;G-AEP)...LABEL, MODEL NUMBER (AE4)		29	4-885-843-02	(302ES)...LABEL, CAUTION, LASER	
11	*4-908-439-01	(302).....PLATE, BOTTOM		30	*4-885-838-01	(302ES)...LABEL, CLASS 1	
	*4-908-439-11	(302ES,520ES)...PLATE, BOTTOM		31	7-685-751-09	SCREW +BVTT 3X6 (S)	
12	4-887-290-00	LEG, RUBBER		32	*4-884-680-00	(302;Canadian)...LABEL	
13	*4-908-447-01	SHEET, INSULATING		902	*1-611-717-11	PC BOARD, N	
14	*4-908-409-01	BRACKET, REMOTE CONTROL		911	*1-614-017-11	(302).....PC BOARD, LAMP	

4 5 6 7 8 9 10 11

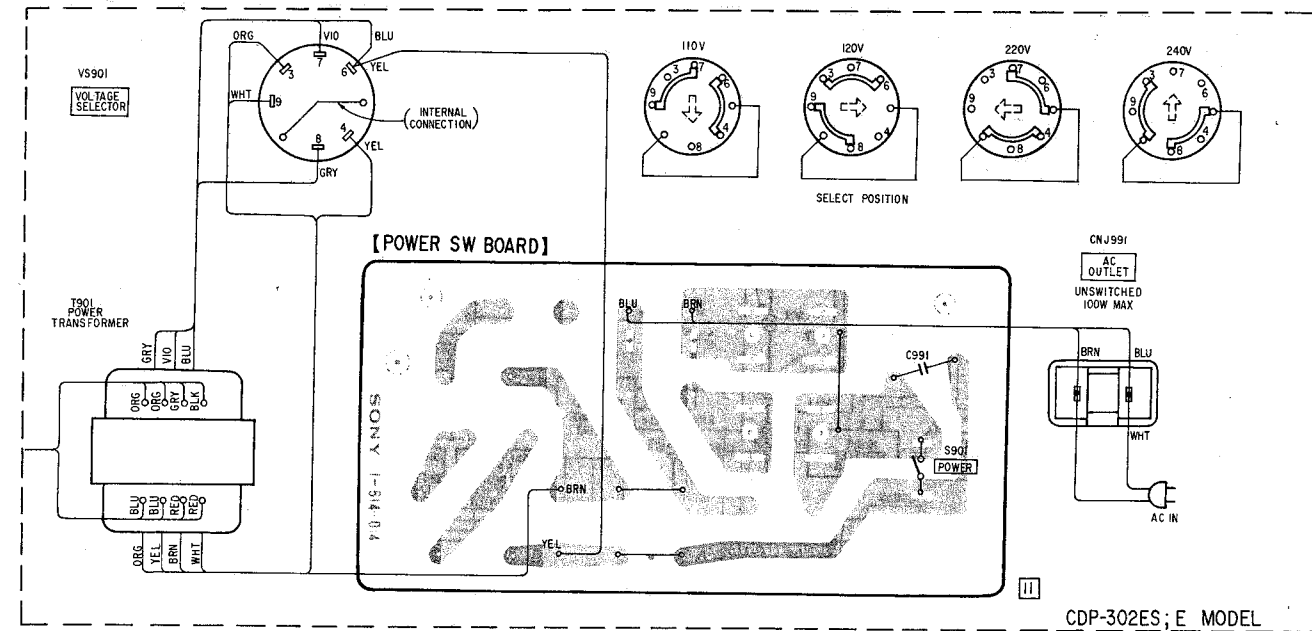

CDP-302ES; E MODEL

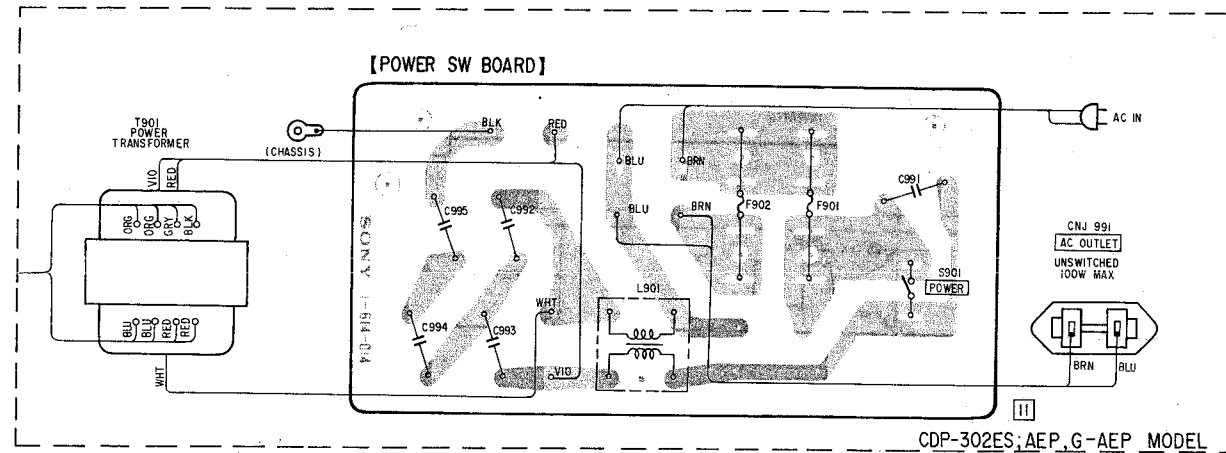

CDP-302ES; AEP, G-AEP MODEL

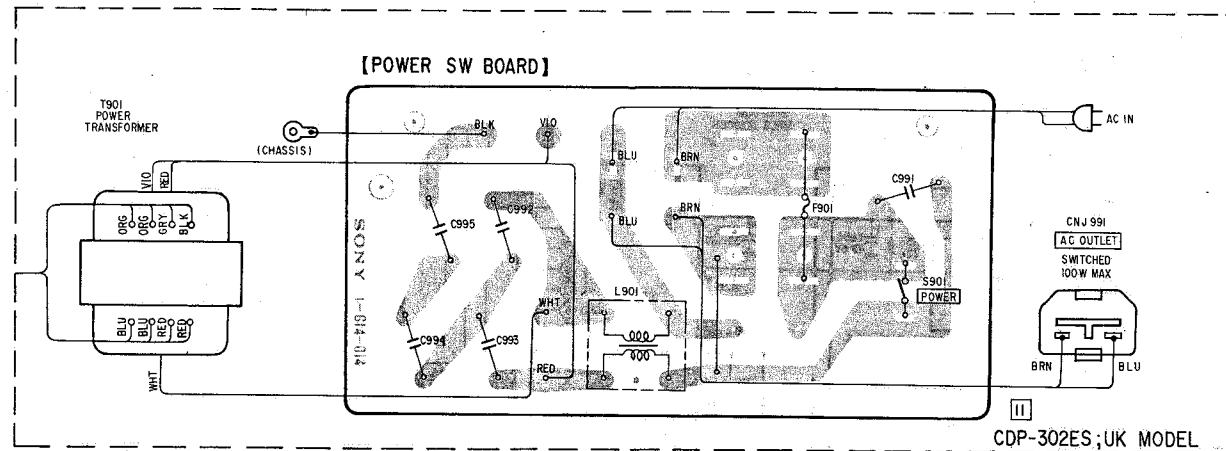

CDP-302ES; UK MODEL



Note: Les composants identifiés par un trame et une marque  sont critiques pour la sécurité. Ne les remplacer que par une pièce portant le numéro spécifié.

Note: The components identified by shading and mark  are critical for safety. Replace only with part number specified.

SECTION 6

EXPLODED VIEWS AND PARTS LIST

NOTE:
 • The mechanical parts with no reference number in the exploded views are not supplied.
 • Items marked " * " are not stocked since they are seldom required for routine service. Some delay should be anticipated when ordering these items.
 • The construction parts of an assembled part are indicated with a collation number on the remark column.

The components identified by shading and mark  are critical for safety. Replace only with part number specified.
 Les composants identifiés par une trame et une marque  sont critiques pour la sécurité. Ne les remplacer que par une pièce portant le numéro spécifié.

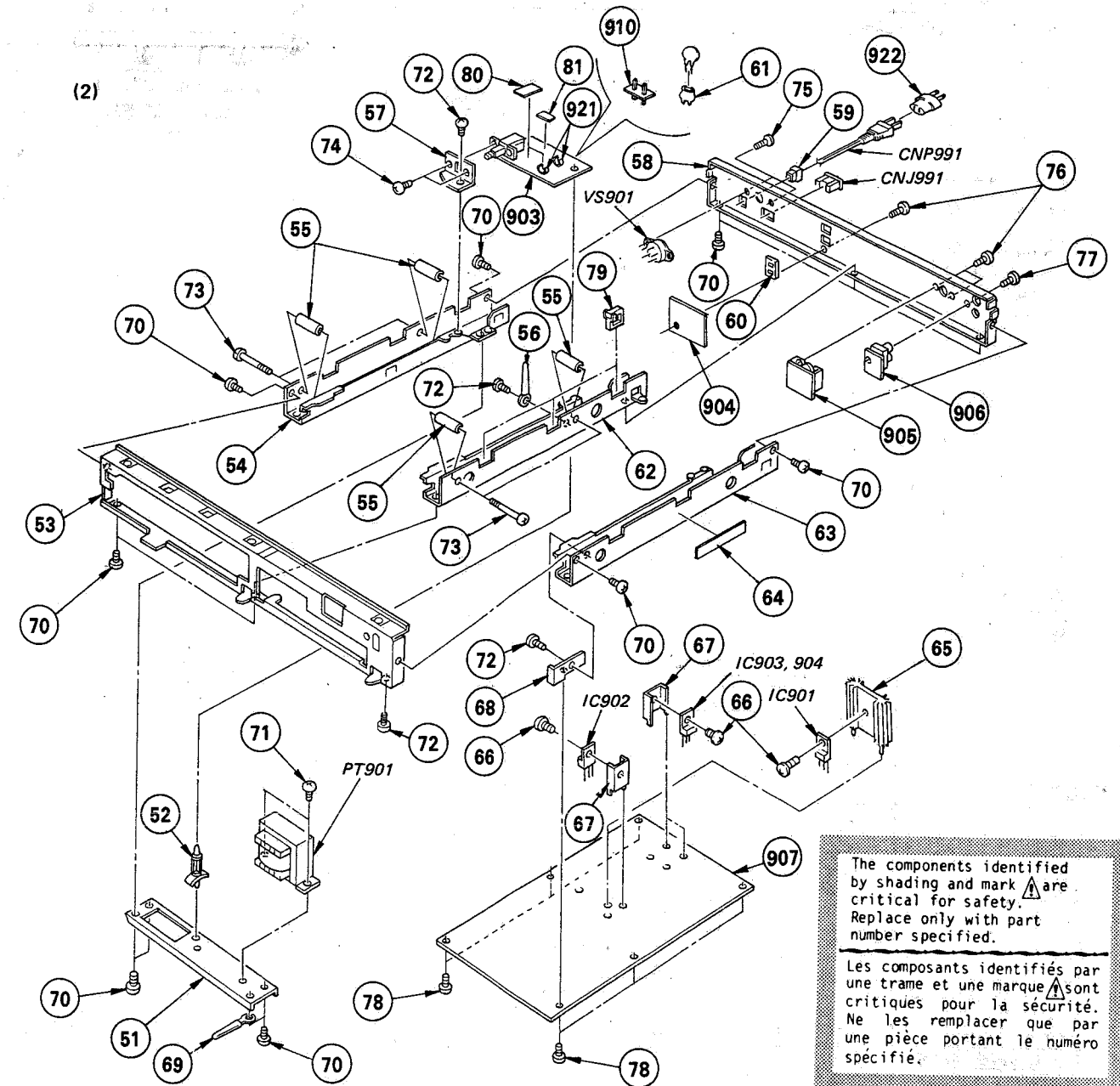
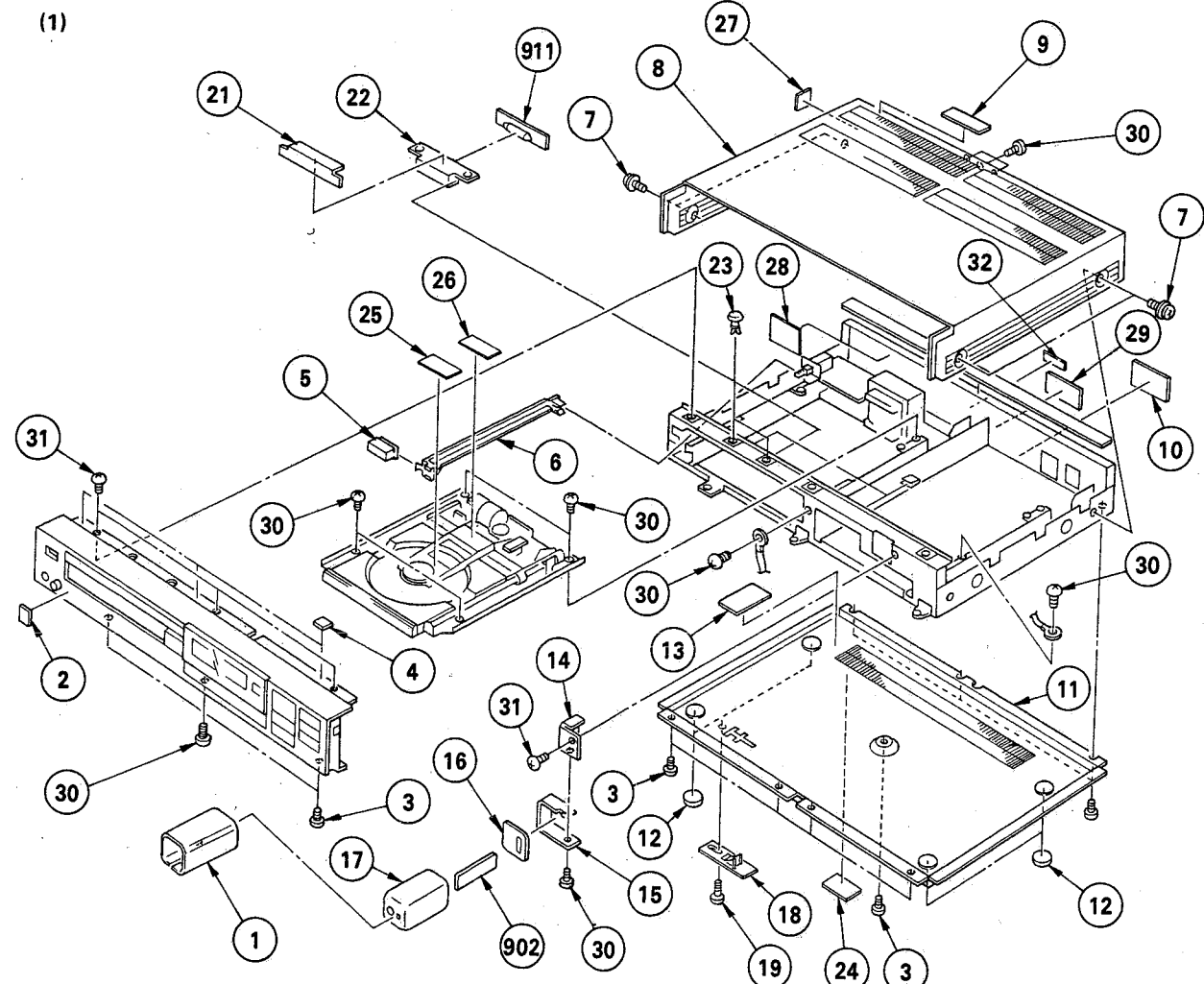

No.	Part No.	Description	REMARKS	No.	Part No.	Description	REMARKS
1	*4-884-637-00	SHEET (C), INSULATING		15	*4-908-408-01	PLATE, FIXED, CATCHER, RAY	
2	3-703-710-41	(302ES,520ES)...STICKER, SONY SYMBOL(12)		16	*4-342-118-00	LID, SHIELD CASE, R	
3	3-703-685-21	SCREW (+BV 3X8)		17	*4-342-117-00	CASE, SHIELD (MAIN), R	
4	9-911-840-XX	CUSHION		18	*4-908-600-01	LEVER, LOCK, TRANSPORT	
5	3-318-911-11	KNOB (POWER.L.), T MOLD		19	3-323-470-01	SCREW (B3X6), (+ -)	
6	*4-908-425-01	LEVER, POWER SWITCH		20	3-831-441-XX	CUSHION	
7	4-889-321-31	SCREW		21	*4-908-459-01	(302)...PLATE, LIGHT INTERCEPTION	
8	4-908-438-01	CASE		22	*4-908-458-01	(302)...BRACKET, LAMP	
9	4-885-831-00	LABEL, CAUTION		23	4-812-134-00	(302)...RIVET NYLON, 3.5	
10	*4-908-449-01	(302)...LABEL, MODEL NUMBER (U)		24	3-703-079-21	(302ES;UK)...LABEL, CAUTION (BACK)	
	*4-908-450-01	(520ES)...LABEL, MODEL NUMBER (U)			*3-703-680-00	(302,520ES)...LABEL, CAUTION, SUB, NEW UL	
	*4-908-453-01	(302ES;AEP)...LABEL, MODEL NUMBER (AE1)		25	4-908-404-01	(302ES)...LABEL, APARTURTE, LASER, DHHS	
	*4-908-455-01	(302ES;UK)...LABEL, MODEL NUMBER (UK)		26	4-908-402-01	(302,520ES)...LABEL, INTERLOCK, DHHS	
	*4-908-457-01	(302ES;E)...LABEL, MODEL NUMBER (E2/3)		27	4-908-401-01	(302,520ES)...LABEL, HOUSING, DHHS	
	*4-908-463-01	(302ES;G-AEP)...LABEL, MODEL NUMBER (AE4)		28	4-885-843-02	(302ES)...LABEL, CAUTION, LASER	
11	*4-908-439-01	(302)...PLATE, BOTTOM		29	*4-885-838-01	(302ES)...LABEL, CLASS 1	
	*4-908-439-11	(302ES,520ES)...PLATE, BOTTOM		30	7-685-751-09	SCREW +BVTT 3X6 (S)	
12	4-887-290-00	LEG, RUBBER		31	7-685-872-09	SCREW +BVTT 3X8 (S)	
13	*4-908-447-01	SHEET, INSULATING		32	*4-884-680-00	(302;Canadian)...LABEL	
14	*4-908-409-01	BRACKET, REMOTE CONTROL		902	*1-611-717-11	PC BOARD, N	
				911	*1-614-017-11	(302)...PC BOARD, LAMP	

No.	Part No.	Description	REMARKS	No.	Part No.	Description	REMARKS
51	*4-908-424-01	BRACKET, TRANSFORMER		68	*4-908-406-01	BRACKET, PC BOARD	
52	*3-703-353-07	SUPPORT, PC BOARD		69	3-703-150-11	CLAMP	
53	*4-908-437-01	PANEL, SUB		70	7-685-872-09	SCREW +BVTT 3X8 (S)	
54	*4-908-432-01	FRAME (LEFT)		71	7-685-880-01	SCREW +BVTT 4X6 (S)	
55	*3-312-427-00	SPACER (3X22)		72	7-685-751-09	SCREW +BVTT 3X6 (S)	
56	3-701-822-00	HOLDER, WIRE		73	7-685-879-01	SCREW +BVTT 3X30 (S)	
57	*4-908-407-01	BRACKET, POWER SWITCH		74	7-682-147-09	SCREW +P 3X6	
58	*4-908-444-01	(302;US)...PLATE, JACK		75	7-621-775-20	SCREW +B 2.6X5	
	*4-908-444-11	(302;Canadian)...PLATE, JACK		76	7-685-134-19	SCREW +BTP 2.6X8 TYPE2 N-S	
	*4-908-444-51	(520ES)...PLATE, JACK		77	3-703-473-00	SCREW, TERMINAL	
	*4-908-444-61	(302ES;AEP,G-AEP)...PLATE, JACK		78	7-685-752-04	SCREW +BVTT 3X8 (S)	
	*4-908-444-71	(302ES;UK)...PLATE, JACK		79	4-308-840-00	HOLDER, WIRE	
	*4-908-444-81	(302ES;E)...PLATE, JACK		80	*3-701-948-14	(302ES;AEP,GAEP)...LABEL, FUSE	
59	3-703-244-00	(302;Canadian,302ES,520ES)...BUSHING, CORD		81	3-701-948-18	(302ES;UK)...LABEL, FUSE	
	3-703-571-11	(302;US)...BUSHING (S), CORD		903	*1-614-014-11	PC BOARD, P.SW	
60	*3-322-818-01	HOLDER, CONNECTOR		904	*1-614-016-11	PC BOARD, SIRCS	
61	4-875-455-02	(302ES;AEP,G-AEP,UK)...CAVER (DIA 20), CAPACITOR		905	*1-614-021-11	PC BOARD, ACC	
62	*4-908-431-01	FRAME (INNER)		906	*1-614-019-11	PC BOARD, LINE OUT	
63	*4-908-430-01	FRAME (RIGHT)		907	*A-4651-033-A	(302)...MOUNTED PCB, MAIN	
64	*3-701-030-00	LABEL, SERIAL NUMBER			A-4651-034-A	(302ES,520ES)...MOUNTED PCB, MAIN	
65	*4-902-345-01	HEAT SINK		921	1-533-131-00	(302ES;AEP,G-AEP,UK)...HOLDER, FUSE	
66	2-259-121-00	SCREW, TR		922	*1-526-565-00	(302ES;E)...AC PLUG ADAPTOR	
67	*4-908-502-01	HEAT SINK					

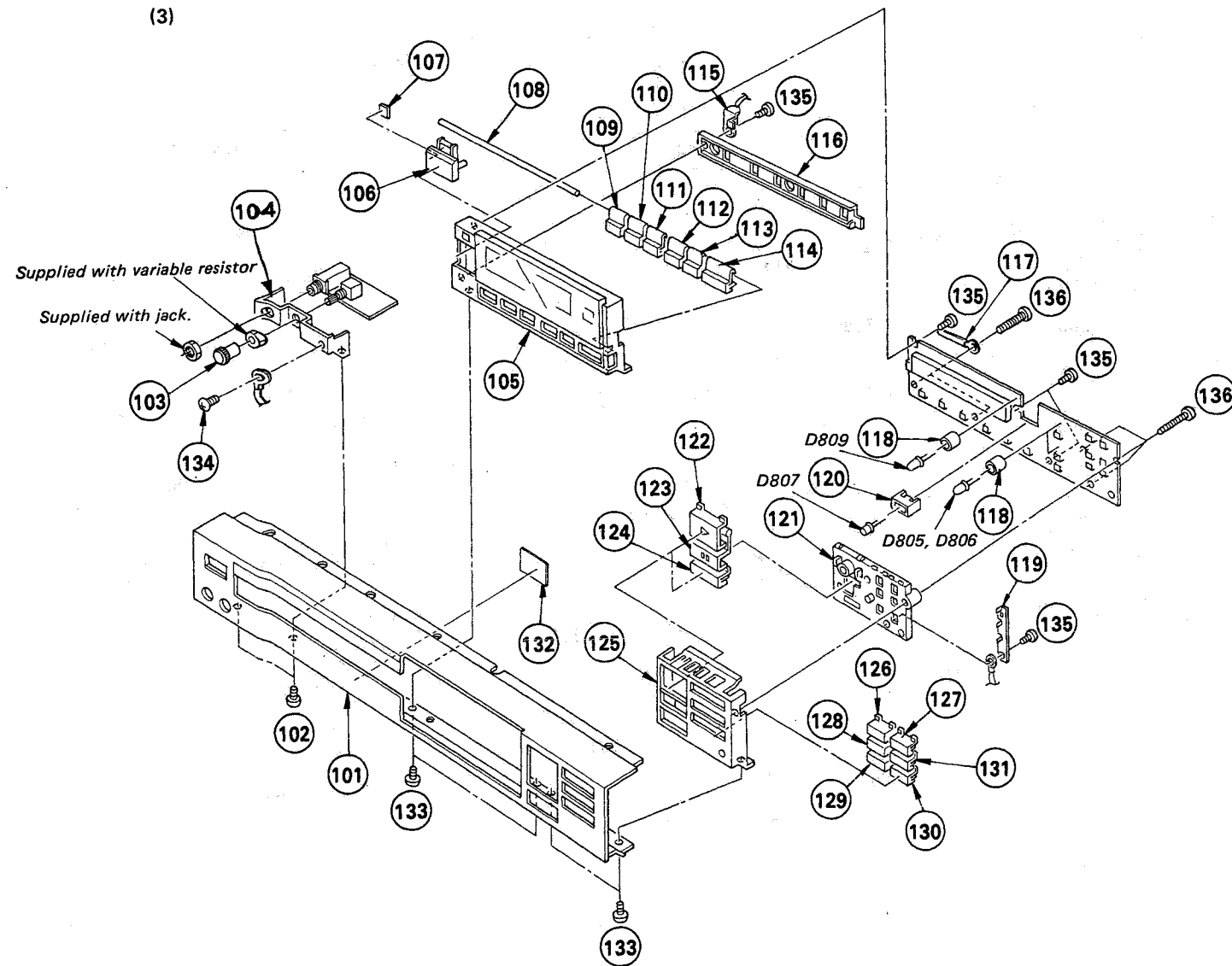

No.	Part No.	Description	REMARKS	No.	Part No.	Description	REMARKS
101	X-4908-410-1	(302ES)...FRONT PANEL ASSY		119	4-908-423-01	SPACER, BUTTON	
	X-4908-411-1	(302)...FRONT PANEL ASSY		120	4-908-554-01	HOLDER, LED	
	X-4908-413-1	(520ES)...FRONT PANEL ASSY		121	4-908-429-01	PLATE (B), SWITCH	
102	3-703-108-21	SCREW +BV 3X6, S TIGHT		122	X-4908-404-1	PLAY KNOB ASSY	
103	4-902-067-11	KNOB, CONTROL		123	X-4908-405-1	PAUSE KNOB ASSY	
104	*4-908-426-01	BRACKET, HEADPHONE		124	4-908-414-41	KNOB (B) (BLACK), T	
105	X-4908-406-1	FROSTED PLATE HOLDER (B) ASSY		125	4-908-436-01	HOLDER, CONTROL BUTTON	
106	X-4908-402-1	BUTTON (B) ASSY, OPEN/CLOSE		126	4-908-415-01	KNOB (AMS), T	
107	9-911-844-XX	RUBBER, BRAKE		127	4-908-415-11	KNOB (AMS), T	
108	4-908-412-01	SHAFT, BUTTON		128	4-908-414-01	KNOB (B) (BLACK), T	
109	4-908-413-01	KNOB (A) (BLACK), T		129	4-908-414-21	KNOB (B) (BLACK), T	
110	4-908-413-11	KNOB (A) (BLACK), T		130	4-908-414-31	KNOB (B) (BLACK), T	
111	4-908-413-21	KNOB (A) (BLACK), T		131	4-908-414-11	KNOB (B) (BLACK), T	
112	4-908-413-31	KNOB (A) (BLACK), T		132	3-831-441-XX	CUSHION	
113	4-908-413-41	KNOB (A) (BLACK), T		133	7-685-646-19	SCREW +BVTP 3X8 TYPE2 N-S	
114	4-908-413-51	KNOB (A) (BLACK), T		134	7-685-751-09	SCREW +BVTT 3X6 (S)	
115	*4-908-446-01	PLATE, GROUND		135	7-685-134-19	SCREW +BTP 2.6X8 TYPE2 N-S	
116	4-908-428-01	PLATE (A), SWITCH		136	7-685-538-14	SCREW +BTP 2.6X16 TYPE2 N-S	
117	3-701-822-00	HOLDER, WIRE		908	*1-614-015-11	PC BOARD, H.P	
118	3-886-569-00	TUBE, RUBBER		909	*1-614-013-11	PC BOARD, DISPLAY	

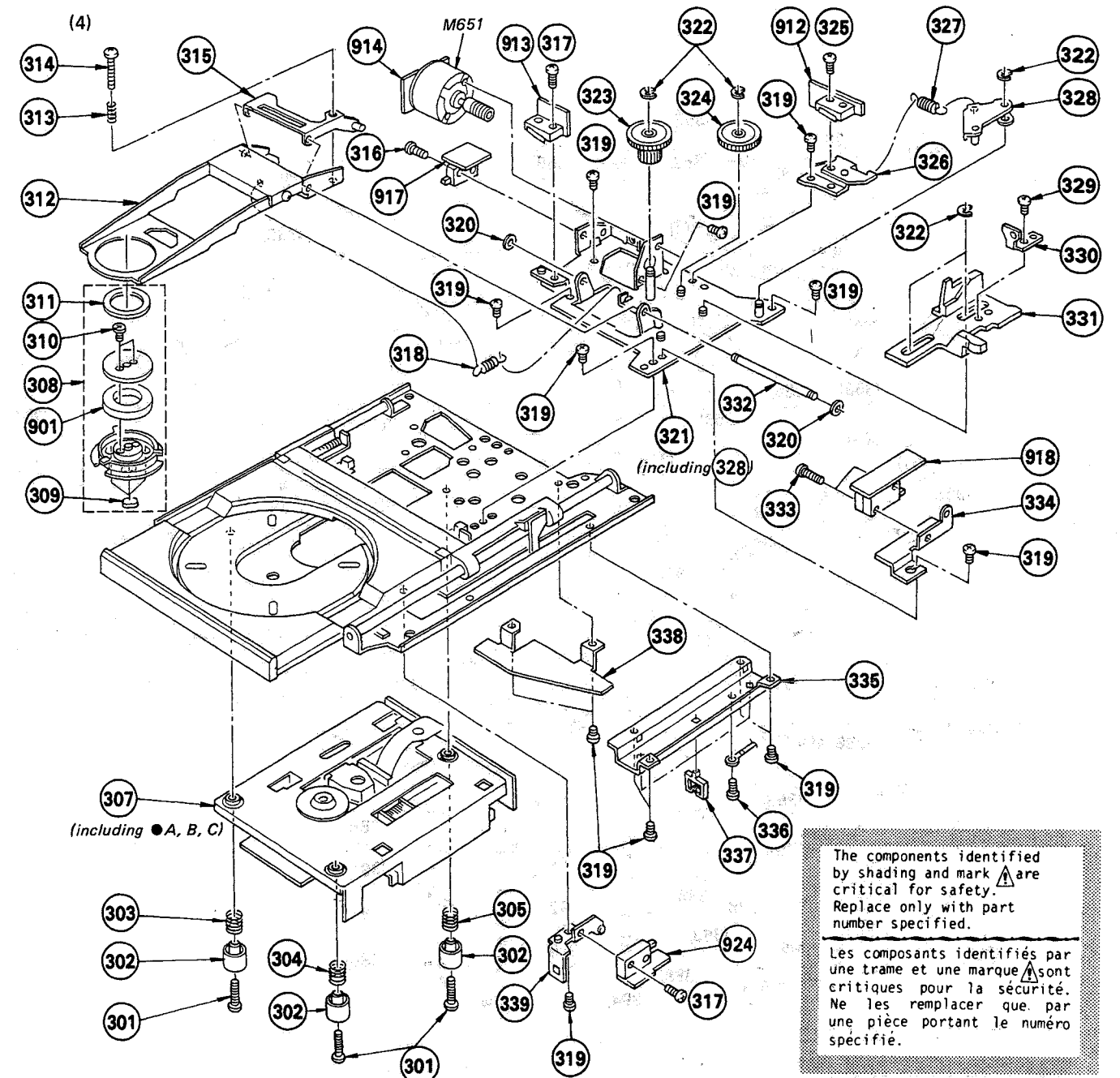

The components identified by shading and mark Δ are critical for safety. Replace only with part number specified.

Les composants identifiés par une trame et une marque Δ sont critiques pour la sécurité. Ne les remplacer que par une pièce portant le numéro spécifié.

No.	Part No.	Description	REMARKS	No.	Part No.	Description	REMARKS
301	7-682-553-09	SCREW +B 3X20		325	7-621-257-55	SCREW +P 2.3X8	
302	4-908-592-01	POLE (A), INSULATOR		326	*4-908-522-01	BRACKET (B), SWITCH	
303	4-908-594-01	SPRING, COMPRESSION		327	4-908-556-01	SPRING, TENSION (LOCK LEVER)	
304	4-908-595-01	SPRING, COMPRESSION		328	*X-4908-504-1	LEVER ASSY, LOCK	
305	4-908-596-01	SPRING, COMPRESSION		329	7-685-132-19	SCREW +BTP 2.6X8 TYPE2 N-S	
307	Δ X-4908-203-1	BU-1 BASE UNIT		330	*4-908-521-01	PLATE, SWITCH	
308	A-4675-077-A	PULLEY ASSY, PRESS		331	4-908-570-01	CAM, C	
309	4-908-537-01	FELT, PRESS		332	4-908-513-01	SHAFT, FULCRUM, C ARM	
310	4-908-618-01	SCREW (+BTP)(2X4)		333	7-621-259-80	SCREW +P 2.6X14	
311	4-908-551-01	CUSHION		334	*4-908-532-01	BRACKET (A), SWITCH	
312	*X-4908-510-1	ARM ASSY, C		335	*4-908-508-01	COVER, ROPE	
313	4-908-559-01	SPRING, COMPRESSION		336	7-685-751-04	SCREW +PTT 3X6 (S)	
314	7-621-775-80	SCREW +B 2.6X16		337	4-308-840-00	HOLDER, WIRE	
315	X-4908-513-1	PLATE ASSY, ADJUSTMENT, ARM		338	*4-908-597-01	COVER, BELT	
316	7-685-864-01	SCREW +BVTT 2.6X10 (S)		339	*4-908-541-01	BRACKET (C), SWITCH	
317	7-621-284-30	SCREW +P 2.6X8		340	4-908-621-01	SHEET	
318	4-908-555-01	SPRING, TENSION (C ARM)		901	1-452-340-11	MAGNET	
319	7-621-259-10	SCREW +P 2.6X3		912	*1-614-023-11	PC BOARD, L.C SW	
320	3-558-708-21	WASHER, STOPPER		913	*1-614-024-11	PC BOARD, CHUCKING SW	
321	*X-4908-509-1	CHASSIS ASSY, SUB		914	*1-614-025-11	PC BOARD, CHUCKING MOTOR	
322	7-624-106-04	STOP RING 3.0, TYPE -E		917	*1-614-028-11	PC BOARD, LASER SW	
323	4-908-528-01	GEAR (A)		918	*1-614-029-11	PC BOARD, LOAD IN SW	
324	4-908-529-01	GEAR (B)		924	*1-614-030-11	PC BOARD, LOAD OUT SW	

(5)

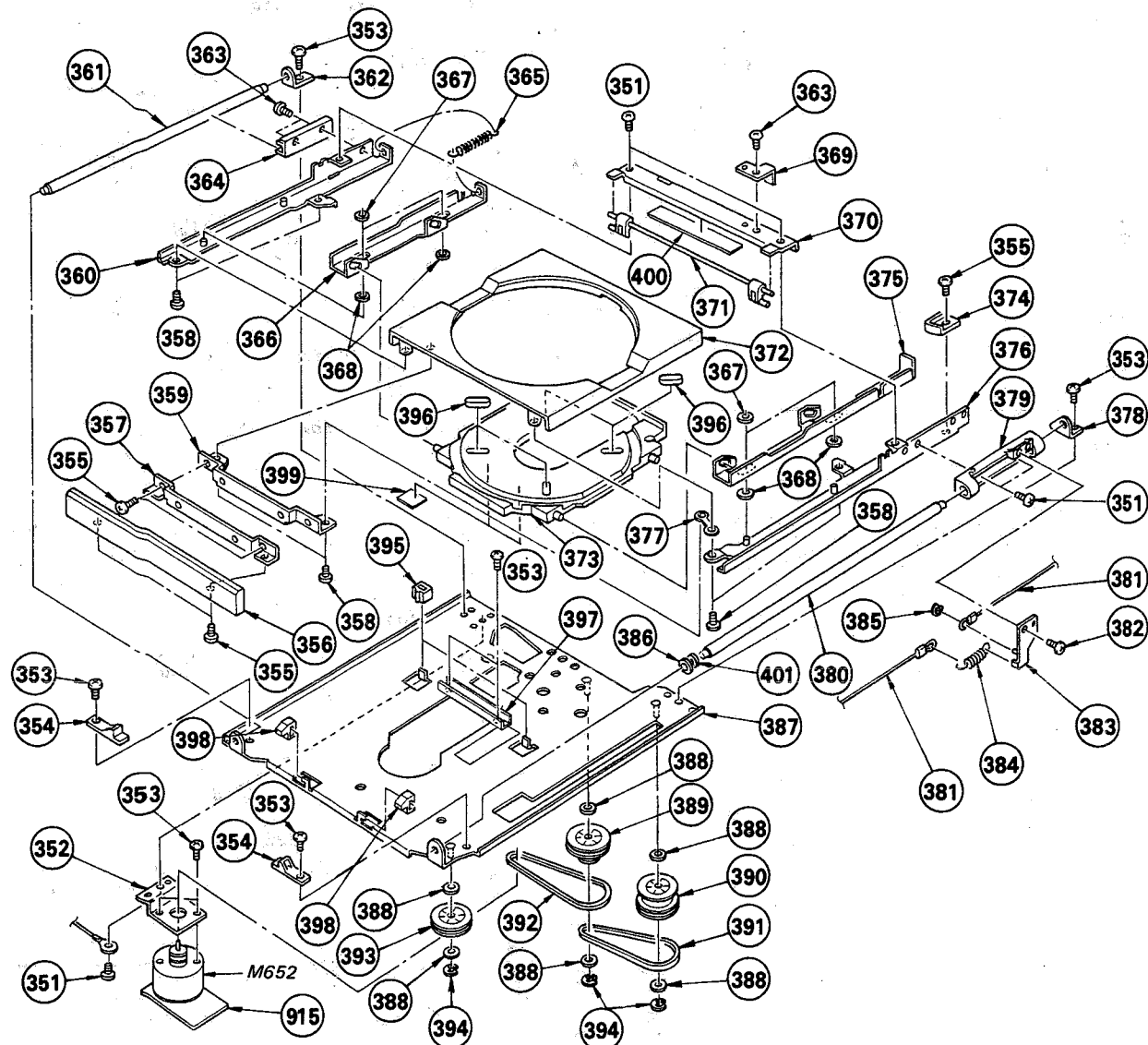

No.	Part No.	Description	REMARKS	No.	Part No.	Description	REMARKS
351	7-685-870-09	SCREW +BVTT 3X5 (S)		377	*4-908-608-01	PLATE (A), GROUND	
352	*4-908-523-01	BRACKET, MOTOR		378	*4-908-531-01	PLATE (RIGHT), BEARING	
353	7-621-259-10	SCREW +P 2.6X3		379	4-908-574-01	BEARING (RIGHT), GUIDE	
354	4-908-540-01	GUIDE, ASSIST		380	4-908-503-01	SHAFT (RIGHT), GUIDE	
355	7-621-775-20	SCREW +B 2.6X5		381	4-908-544-01	ROPE	
356	4-908-571-11	PANEL, LOADING		382	7-685-132-19	SCREW +BTP 2.6X5 TYPE2 N-S	
357	*4-908-539-01	BRACKET (B), LOADING PANEL		383	*X-4908-502-1	BRACKET ASSY, ROPE	
358	7-685-646-29	SCREW +BVTP 3X8 TYPE2 SLIT		384	4-908-553-01	SPRING, COMPRESSION (ROPE)	
359	*4-908-538-01	BRACKET (A), LOADING PANEL		385	7-624-104-04	STOP RING 2.0, TYPE -E	
360	X-4908-508-1	PLATE ASSY (LEFT), SIDE, TABLE		386	4-908-550-01	STOPPER, RUBBER	
361	4-908-505-01	SHAFT (LEFT), GUIDE		387	*X-4908-511-1	CHASSIS ASSY, MECHANICAL	
362	*4-908-530-01	PLATE (LEFT), BEARING		388	3-701-441-21	WASHER	
363	7-685-861-09	SCREW +BVTT 2.6X5 (S)		389	4-908-519-01	PULLEY (A)	
364	4-908-572-01	BEARING (LEFT), GUIDE		390	4-908-525-01	PULLEY (C)	
365	4-908-552-01	SPRING, COMPRESSION		391	3-671-077-00	BELT, FF	
366	*4-908-562-01	PLATE (LEFT), CAM, DISK		392	4-908-591-01	BELT, DRIVING	
367	3-558-708-21	WASHER, STOPPER		393	4-908-524-01	PULLEY (B)	
368	3-701-439-11	WASHER		394	7-624-106-04	STOP RING 3.0, TYPE -E	
369	*4-908-609-01	PLATE (B), GROUND		395	4-887-175-00	RUBBER, STOPPER	
370	*4-908-533-01	REINFORCEMENT, TABLE		396	4-908-543-01	RETAINER, DISK	
371	4-908-534-01	LEVER, FUNCTION		397	*4-908-598-01	REINFORCEMENT, CHASSIS	
372	4-908-584-01	TABLE, DISK		398	4-908-590-01	RETAINER, TABLE	
373	X-4908-506-1	PLATE ASSY, DISK		399	*4-908-964-01	SHEET, PS, DT	
374	4-908-520-01	PLATE, LOCK		400	*4-908-965-01	SHEET	
375	*4-908-561-01	PLATE (RIGHT), CAM, DISK		401	4-908-622-01	CUSHION (S)	
376	X-4908-507-1	PLATE ASSY (RIGHT), SIDE, TABLE		915	*1-614-026-11	PC BOARD, LOADING MOTOR	

(6)

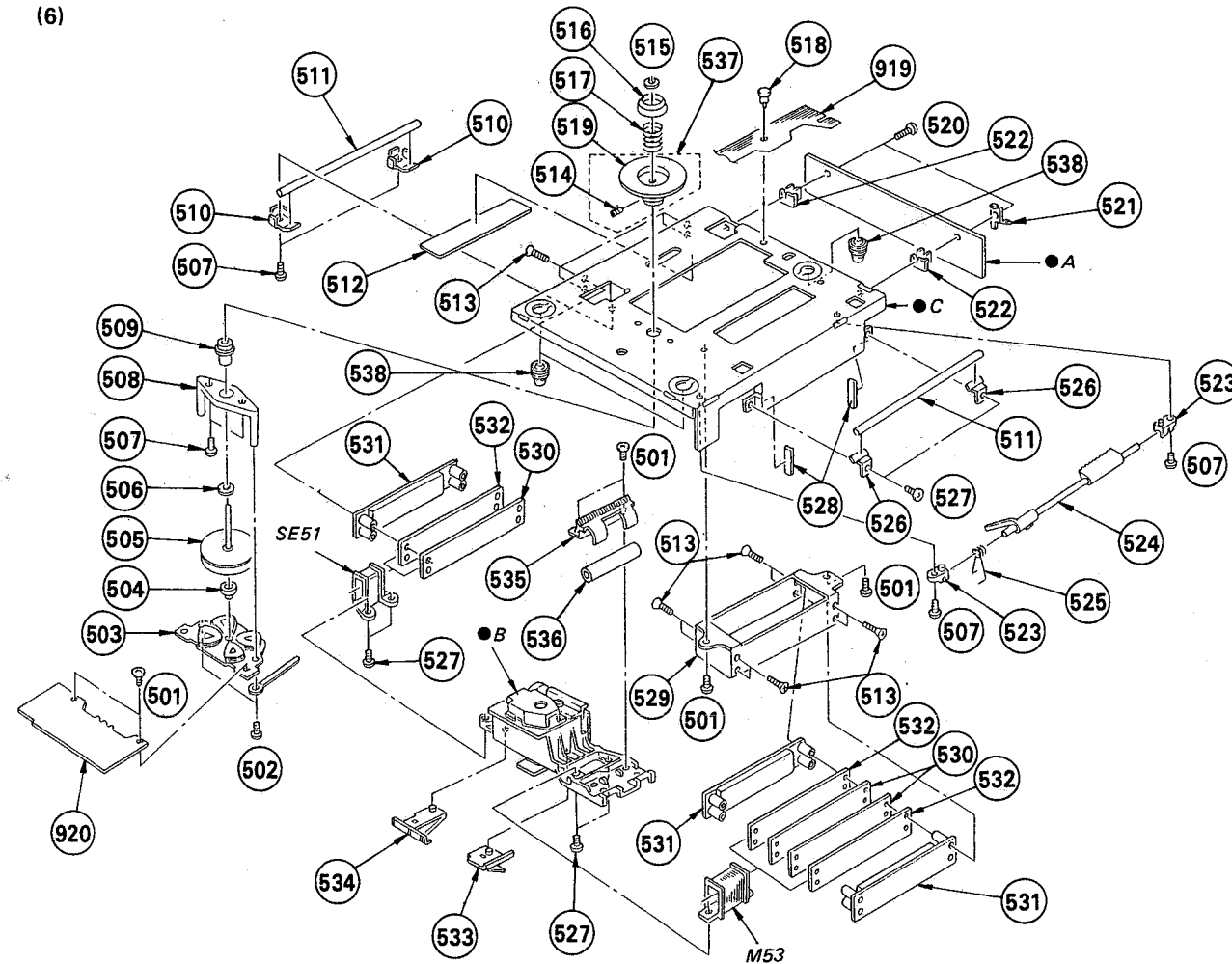

No.	Part No.	Description	REMARKS	No.	Part No.	Description	REMARKS
501	7-621-775-10	SCREW +B 2.6X4		521	*4-908-232-01	LUG	
502	7-685-533-19	SCREW +BTP 2.6X6 TYPE2 N-S		522	4-908-222-01	HOLDER, PC BOARD	
503	A-4675-068-A	BRACKET ASSY, MOTOR (L151,152)		523	4-908-220-01	HOLDER, ROD	
504	2-622-105-01	RETAINER, THRUST		524	4-908-227-01	LEVER, LOCK	
505	A-4675-069-A	ROTOR ASSY		525	4-908-230-01	SPRING	
506	3-701-439-21	WASHER		526	4-908-217-01	RETAINER (B), SLIDE SHAFT	
507	7-621-773-95	SCREW +B 2.6X6		527	7-621-775-20	SCREW +B 2.6X5	
508	4-908-216-01	HOLDER, STATOR		528	*3-548-366-02	CUSHION	
509	4-908-206-01	BEARING, SPINDLE		529	4-908-203-01	YOKE (A)	
510	4-908-205-01	RETAINER (A), SLIDE SHAFT		530	4-908-214-01	YOKE (C)-1	
511	4-908-201-01	SHAFT, SLIDE		531	A-4675-070-A	MAGNET ASSY, LINEAR	
512	2-270-836-00	RUBBER, RETAINER		532	4-908-215-01	YOKE (C)-2	
513	7-621-559-80	SCREW +K 2.6X14		533	4-908-225-01	RETAINER (A), LEAD	
514	7-621-734-09	SET-SCT, HEX. 2.6X3		534	4-908-219-01	RETAINER (B), LEAD	
515	3-558-708-21	WASHER, STOPPER		535	4-908-224-01	HOLDER, BEARING	
516	4-908-212-01	CAP, CENTERING		536	4-908-221-01	BEARING	
517	4-908-213-01	SPRING, COMPRESSION		537	X-4908-202-1	PULLEY ASSY, DISK	
518	3-531-576-01	RIVET		538	4-908-593-01	INSULATOR	
519	4-908-211-02	PULLEY, DISK		919	A-4646-215-A	MOUNTED PCB, FLEXIBLE	
520	7-621-259-65	SCREW +P 2.6X10		920	1-614-086-11	PC BOARD, BSL MOTOR	

CDP-302/302ES/520ES

NOTE:

Items marked " * " are not stocked since they are seldom required for routine service. Some delay should be anticipated when ordering these items.

If there are two or more same circuits in a set such as a stereophonic machine, only typical circuit parts may be indicated and capacitors and resistors in other same circuits may be omitted.

CAPACITORS:

MF:µF, PF:µuF.

RESISTORS

All resistors are in ohms.
F : nonflammable

COILS

MMH : mH, UH : µH

SEMICONDUCTORS

In each case, U : µ, for example:
UA...: µA..., UPA...: µPA..., UPC...: µPC,
UPD...: µPD...

The components identified by shading and mark Δ are critical for safety. Replace only with part number specified.

Les composants identifiés par une trame et une marque Δ sont critiques pour la sécurité. Ne les remplacer que par une pièce portant le numéro spécifié.

ELECTRICAL PARTS

Ref.No.	Part No.	Description			
901	1-452-340-11	MAGNET			
902	*1-611-717-11	PC BOARD, N			
903	*1-614-014-11	PC BOARD, P.SW			
904	*1-614-016-11	PC BOARD, SIRCS			
905	*1-614-021-11	PC BOARD, ACC			
906	*1-614-019-11	PC BOARD, LINE OUT			
907	*A-4651-033-A	(302).....MOUNTED PCB, MAIN			
	A-4651-034-A	(302ES,520ES)...MOUNTED PCB, MAIN			
908	*1-614-015-11	PC BOARD, H.P			
909	*1-614-013-11	PC BOARD, DISPLAY			
910	*1-535-139-00	BASE POST 19MM (10MM PITCH) 2P			
911	*1-614-017-11	(302)....PC BOARD, LAMP			
912	*1-614-023-11	PC BOARD, L.C SW			
913	*1-614-024-11	PC BOARD, CHUCKING SW			
914	*1-614-025-11	PC BOARD, CHUCKING MOTOR			
915	*1-614-026-11	PC BOARD, LOADING MOTOR			
916				
917	*1-614-028-11	PC BOARD, LASER SW			
918	*1-614-029-11	PC BOARD, LOAD IN SW			
919	A-4646-215-A	MOUNTED PCB, FLEXIBLE			
920	*1-614-086-11	PC BOARD, BSL MOTOR			
921	1-533-131-00	(302ES;AEP,G-AEP,UK)...HOLDER, FUSE			
922	1-526-565-00	(302ES;E)...AC PLUG ADAPTOR			
923				
924	*1-614-030-11	PC BOARD, LOAD OUT SW			
C51	1-135-008-00	TANTALUM(CHIP)2.2MF	20%	6.3V	
C151	1-162-302-31	CERAMIC	0.0022MF	20%	16V
C152	1-162-302-31	CERAMIC	0.0022MF	20%	16V
C153	1-161-494-00	CERAMIC	0.022MF	30%	25V
C154	1-161-494-00	CERAMIC	0.022MF	30%	25V
C201	1-136-169-00	FILM	0.22MF	5%	50V
C202	1-162-302-31	CERAMIC	0.0022MF	30%	16V
C203	1-136-165-00	FILM	0.1MF	5%	50V
C204	1-162-290-31	CERAMIC	470PF	10%	50V
C205	1-130-475-00	MYLAR	0.0022MF	5%	50V
C206	1-131-371-00	TANTALUM	10MF	10%	16V
C207	1-136-159-00	FILM	0.033MF	5%	50V
C208	1-136-169-00	FILM	0.22MF	5%	50V
C209	1-136-161-00	FILM	0.047MF	5%	50V
C210	1-162-294-31	CERAMIC	0.001MF	10%	50V
C211	1-162-302-31	CERAMIC	0.0022MF	30%	16V
C212	1-130-487-00	MYLAR	0.022MF	5%	50V
C213	1-162-291-31	CERAMIC	560PF	10%	50V
C214	1-130-475-00	MYLAR	0.0022MF	5%	50V
C215	1-136-165-00	FILM	0.1MF	5%	50V
C216	1-130-487-00	MYLAR	0.022MF	5%	50V

ELECTRICAL PARTS

Ref.No.	Part No.	Description			
C217	1-136-165-00	FILM	0.1MF	5%	50V
C218	1-162-304-31	CERAMIC	0.0047MF	30%	16V
C219	1-136-163-00	FILM	0.068MF	5%	50V
C221	1-123-318-00	ELECT	33MF	20%	16V
C222	1-123-318-00	ELECT	33MF	20%	16V
C223	1-131-369-00	TANTALUM	4.7MF	10%	16V
C235	1-162-294-31	CERAMIC	0.001MF	10%	50V
C236	1-136-169-00	FILM	0.22MF	5%	50V
C237	1-136-161-00	FILM	0.047MF	5%	50V
C301	1-123-356-00	ELECT	10MF	20%	50V
C302	1-162-302-31	CERAMIC	0.0022MF	30%	16V
C303	1-162-302-31	CERAMIC	0.0022MF	30%	16V
C304	1-102-725-00	CERAMIC	36PF	5%	50V
C305	1-102-658-00	CERAMIC	180PF	5%	50V
C306	1-102-647-00	CERAMIC	39PF	5%	50V
C307	1-102-523-00	CERAMIC	56PF	5%	50V
C308	1-162-294-31	CERAMIC	0.001MF	10%	50V
C309	1-102-514-00	CERAMIC	22PF	5%	50V
C310	1-123-318-00	ELECT	33MF	20%	16V
C311	1-123-318-00	ELECT	33MF	20%	16V
C312	1-123-318-00	ELECT	33MF	20%	16V
C313	1-123-318-00	ELECT	33MF	20%	16V
C314	1-162-284-31	CERAMIC	150PF	10%	50V
C315	1-162-284-31	CERAMIC	150PF	10%	50V
C316	1-123-318-00	ELECT	33MF	20%	16V
C317	1-162-306-31	CERAMIC	0.01MF	30%	16V
C318	1-162-306-31	CERAMIC	0.01MF	30%	16V
C319	1-123-318-00	ELECT	33MF	20%	16V
C321	1-130-487-00	MYLAR	0.022MF	5%	50V
C323	1-162-294-31	CERAMIC	0.001MF	10%	50V
C324	1-123-318-00	ELECT	33MF	20%	16V
C325	1-123-318-00	ELECT	33MF	20%	16V
C327	1-123-318-00	ELECT	33MF	20%	16V
C330	1-101-005-00	CERAMIC	0.022MF		50V
C331	1-101-005-00	CERAMIC	0.022MF		50V
C332	1-131-374-00	(302)...TANTALUM	33MF	10%	16V
C333	1-101-005-00	CERAMIC	0.022MF		50V
C334	1-101-005-00	CERAMIC	0.022MF		50V
C348	1-130-483-00	MYLAR	0.01MF	5%	50V
C349	1-123-380-00	ELECT	1MF	20%	50V
C351	1-123-380-00	ELECT	1MF	20%	50V
C353	1-136-165-00	FILM	0.1MF	5%	50V
C354	1-130-481-00	MYLAR	0.0068MF	5%	50V
C355	1-136-169-00	FILM	0.22MF	5%	50V
C356	1-162-290-31	CERAMIC	470PF	10%	50V
C360	1-136-165-00	FILM	0.1MF	5%	50V

CDP-302/302ES/520ES

ELECTRICAL PARTS

Ref.No.	Part No.	Description				
C361	1-123-330-00	ELECT	22MF	20%	25V	
C362	1-123-330-00	ELECT	22MF	20%	25V	
C363	1-161-974-00	CERAMIC	0.1MF	20%	16V	
C364	1-161-974-00	CERAMIC	0.1MF	20%	16V	
C365	1-102-114-00	CERAMIC	470PF	10%	50V	
C366	1-161-974-00	CERAMIC	0.1MF	20%	16V	
C367	1-161-974-00	CERAMIC	0.1MF	20%	16V	
C401	1-104-230-00	POLYSTYRENE	0.0015MF	5%	50V	
C402	1-123-384-00	ELECT	10MF	20%	50V	
C403	1-123-384-00	ELECT	10MF	20%	50V	
C404	1-123-384-00	ELECT	10MF	20%	50V	
C405	1-104-233-00	POLYSTYRENE	220PF	5%	125V	
C406	1-123-384-00	ELECT	10MF	20%	50V	
C407	1-130-967-00	FILM	0.0027MF	3%	100V	
C408	1-136-230-00	FILM	0.0022MF	3%	100V	
C409	1-123-318-00	ELECT	33MF	20%	16V	
C410	1-136-257-00	FILM	0.0039MF	3%	100V	
C411	1-136-252-00	FILM	0.0015MF	3%	100V	
C412	1-123-334-00	(302).....ELECT	220MF	20%	25V	
C412	1-123-694-52	(302ES,520ES)...ELECT	220MF	20%	25V	
C413	1-130-955-00	FILM	0.01MF	3%	100V	
C414	1-104-260-11	POLYSTYRENE	510PF	2%	125V	
C415	1-130-340-00	FILM	0.018MF	3%	100V	
C416	1-130-340-00	FILM	0.018MF	3%	100V	
C417	1-136-252-00	FILM	0.0015MF	3%	100V	
C419	1-123-356-00	ELECT	10MF	20%	50V	
C420	1-123-330-00	(302).....ELECT	22MF	20%	25V	
C420	1-123-700-52	(302ES,520ES)...ELECT	22MF	20%	35V	
C421	1-101-005-00	CERAMIC	0.022MF		50V	
C431	1-123-330-00	ELECT	22MF	20%	25V	
C451	1-162-290-00	CERAMIC	470PF	10%	50V	
C501	1-104-230-00	POLYSTYRENE	0.0015MF	5%	50V	
C502	1-123-384-00	ELECT	10MF	20%	50V	
C503	1-123-384-00	ELECT	10MF	20%	50V	
C504	1-123-384-00	ELECT	10MF	20%	50V	
C505	1-104-233-00	POLYSTYRENE	220PF	5%	125V	
C506	1-123-384-00	ELECT	10MF	20%	50V	
C507	1-130-967-00	FILM	0.0027MF	3%	100V	
C508	1-136-230-00	FILM	0.0022MF	3%	100V	
C509	1-123-318-00	ELECT	33MF	20%	16V	
C510	1-136-257-00	FILM	0.0039MF	3%	100V	
C511	1-136-252-00	FILM	0.0015MF	3%	100V	
C512	1-123-334-00	(302).....ELECT	220MF	20%	25V	
C512	1-123-694-52	(302ES,520ES)...ELECT	220MF	20%	25V	

ELECTRICAL PARTS

Ref.No.	Part No.	Description				
C513	1-130-955-00	FILM	0.01MF	3%	100V	
C514	1-104-260-11	POLYSTYRENE	510PF	2%	125V	
C515	1-130-340-00	FILM	0.018MF	3%	100V	
C516	1-130-340-00	FILM	0.018MF	3%	100V	
C517	1-136-252-00	FILM	0.0015MF	3%	100V	
C519	1-123-356-00	ELECT	10MF	20%	50V	
C520	1-123-330-00	(302).....ELECT	22MF	20%	25V	
C520	1-123-700-52	(302ES,520ES)...ELECT	22MF	20%	35V	
C521	1-101-005-00	CERAMIC	0.022MF		50V	
C531	1-123-330-00	ELECT	22MF	20%	25V	
C551	1-162-290-00	CERAMIC	470PF	10%	50V	
C601	1-162-294-31	CERAMIC	0.001MF	10%	50V	
C602	1-162-294-31	CERAMIC	0.001MF	10%	50V	
C651	1-136-157-00	FILM	0.022MF	5%	50V	
C652	1-136-157-00	FILM	0.022MF	5%	50V	
C653	1-136-157-00	FILM	0.022MF	5%	50V	
C654	1-130-479-00	MYLAR	0.0047MF	5%	50V	
C655	1-130-479-00	MYLAR	0.0047MF	5%	50V	
C701	1-162-306-31	CERAMIC	0.01MF	30%	16V	
C702	1-162-113-00	CERAMIC	0.01MF	30%	16V	
C801	1-162-294-31	CERAMIC	0.001MF	10%	50V	
C851	1-123-611-00	ELECT	1MF	20%	50V	
C852	1-123-613-00	ELECT	3.3MF	20%	50V	
C853	1-162-288-31	CERAMIC	330PF	10%	50V	
C854	1-123-821-00	ELECT	47MF	20%	16V	
C902	1-123-339-00	ELECT	3300MF	20%	25V	
C903	1-124-348-00	ELECT	470MF	20%	35V	
C905	1-123-491-51	(302).....ELECT	4700MF	20%	16V	
C905	1-123-327-00	(302ES,520ES)...ELECT	4700MF	20%	16V	
C906	1-123-311-00	ELECT	1000MF	20%	10V	
C911	1-123-346-00	ELECT	220MF	20%	35V	
C912	1-123-360-00	ELECT	100MF	20%	50V	
C913	1-123-345-00	ELECT	100MF	20%	35V	
C951	1-130-789-00	FILM	1MF	10%	100V	
C952	1-123-339-00	ELECT	3300MF	20%	25V	
C953	1-124-348-00	ELECT	470MF	20%	35V	
C955	1-123-326-00	(302).....ELECT	3300MF	20%	16V	
C955	1-123-339-00	(302ES,520ES)...ELECT	3300MF	20%	25V	
C956	1-123-311-00	ELECT	1000MF	20%	10V	
C961	1-136-173-00	FILM	0.47MF	5%	50V	
C962	1-123-307-00	ELECT	100MF	20%	10V	
C991	▲ 1-161-744-00	CERAMIC	0.01MF		400V	
C992	▲ 1-162-742-00	(302ES)...CERAMIC	0.0022MF	20%	400V	
C993	▲ 1-161-742-00	CERAMIC	0.0022MF	20%	400V	
C994	▲ 1-162-742-00	(302ES)...CERAMIC	0.0022MF	20%	400V	
C995	▲ 1-162-742-00	(302ES)...CERAMIC	0.0022MF	20%	400V	

The components identified by shading and mark ▲ are critical for safety. Replace only with part number specified.

Les composants identifiés par une trame et une marque ▲ sont critiques pour la sécurité. Ne les remplacer que par une pièce portant le numéro spécifié.

ELECTRICAL PARTS

Ref.No.	Part No.	Description
CNJ301	1-562-677-11	SOCKET, CONNECTOR
CNJ411	1-507-912-11	(302).....JACK, PIN 2P
CNJ411	1-507-912-21	(302ES,520ES)...JACK, PIN 2P
CNJ412	1-507-863-11	JACK, LARGE TYPE, HEADPHONES
CNJ511	1-507-912-11	JACK, PIN 2P
△CNP991	1-526-609-00	(302 US, 302ES, E, 520ES).....CONNECTOR, AC OUTLET
△CNP991	1-526-751-11	(302ES,UK).....OUTLET, AC
△CNP991	1-526-794-11	(302ES, AEP, G-AEP).....OUTLET, AC
△CNP991	1-526-882-00	(302 Canadian).....OUTLET, AC
CNP151*1-560-073-00		PIN, CONNECTOR (U TYPE)
CNP201	1-564-710-11	PIN, CONNECTOR (SMALL TYPE) 8P
CNP202*1-564-707-11		PIN, CONNECTOR (SMALL TYPE) 5P
CNP203*1-564-706-11		PIN, CONNECTOR (SMALL TYPE) 4P
CNP301*1-564-507-41		PLUG, CONNECTOR 4P
CNP302	1-564-708-11	(302ES)...PIN, CONNECTOR (SMALL TYPE) 6P
CNP302	1-564-710-11	(302).....PIN, CONNECTOR (SMALL TYPE) 8P
CNP303*1-560-064-00		PIN, CONNECTOR 6P
CNP304*1-564-712-11		PIN, CONNECTOR (SMALL TYPE) 10P
CNP305	1-564-710-11	PIN, CONNECTOR (SMALL TYPE) 8P
CNP306*1-564-505-11		PLUG, CONNECTOR 2P
CNP307*1-564-507-21		PLUG, CONNECTOR 4P
CNP308*1-564-506-11		PLUG, CONNECTOR 3P
CNP309*1-564-506-11		PLUG, CONNECTOR 3P
CNP310*1-564-507-31		PLUG, CONNECTOR 4P
CNP401*1-564-507-41		PLUG, CONNECTOR 4P
CNP402*1-564-509-11		PLUG, CONNECTOR 6P
CNP404*1-564-506-11		PLUG, CONNECTOR 3P
CNP504*1-564-506-11		PLUG, CONNECTOR 3P
CNP601*1-564-519-11		PLUG, CONNECTOR 4P
CNP602*1-564-505-11		PLUG, CONNECTOR 2P
CNP603*1-564-505-21		PLUG, CONNECTOR 2P
CNP604*1-564-505-31		PLUG, CONNECTOR 2P
CNP605*1-564-505-41		PLUG, CONNECTOR 2P
CNP606*1-564-506-11		PLUG, CONNECTOR 3P
CNP607*1-564-517-11		PLUG, CONNECTOR 2P
CNP702*1-564-519-21		PLUG, CONNECTOR 4P
CNP705*1-560-039-00		PIN, CONNECTOR
CNP706*1-560-039-00		PIN, CONNECTOR
CNP708*1-564-725-11		PIN, CONNECTOR (SMALL TYPE) 9P
CNP901*1-564-505-11		PLUG, CONNECTOR 2P
CNP902*1-564-507-11		PLUG, CONNECTOR 4P
△CNP991	1-555-386-00	(302ES, E).....CORD, POWER
△CNP991	1-555-701-00	(520ES).....CORD, POWER
△CNP991	1-555-795-11	(302ES, AEP, G-AEP).....CORD, POWER
△CNP991	1-555-835-11	(302ES, UK).....CORD, POWER
△CNP991	1-555-874-00	(302 US).....CORD, POWER
△CNP991	1-557-577-11	(302 Canadian).....CORD, POWER

ELECTRICAL PARTS

Ref.No.	Part No.	Description
D51	8-719-911-19	DIODE 1SS119
D201	8-719-951-13	DIODE HZ5CLL
D202	8-719-911-19	DIODE 1SS119
D205	8-719-911-19	DIODE 1SS119
D211	8-719-911-19	DIODE 1SS119
D213	8-719-101-32	DIODE RD2.7EL1
D301	8-719-911-19	DIODE 1SS119
D302	8-719-902-39	DIODE KV1236Z
D651	8-719-200-02	DIODE 10E-2
D652	8-719-200-02	DIODE 10E-2
D653	8-719-200-02	DIODE 10E-2
D701	8-719-911-19	DIODE 1SS119
D702	8-719-911-19	DIODE 1SS119
D703	8-719-911-19	DIODE 1SS119
D704	8-719-100-29	DIODE RD5.1EB1
D805	8-719-907-81	DIODE BG5535S
D806	8-719-907-80	DIODE AA5335S
D807	8-719-918-57	DIODE GL-5NG27
D809	8-719-907-81	DIODE BG5535S
D851	8-719-110-32	DIODE PH302B
D901	8-719-200-31	DIODE 21DQ05
D902	8-719-200-31	DIODE 21DQ05
D903	8-719-200-31	DIODE 21DQ05
D904	8-719-200-31	DIODE 21DQ05
D905	8-719-210-12	DIODE 10DF2
D906	8-719-210-12	DIODE 10DF2
D907	8-719-210-12	DIODE 10DF2
D908	8-719-210-12	DIODE 10DF2
D909	8-719-200-02	DIODE 10E-2
D910	8-719-200-02	DIODE 10E-2
D911	8-719-911-19	DIODE 1SS119
D912	8-719-911-19	DIODE 1SS119
D913	8-719-101-07	DIODE RD33EB3
D914	8-719-911-19	DIODE 1SS119
D915	8-719-100-48	DIODE RD8.2EB2
F901	△ 1-532-078-00	(302ES, AEP, G-AEP).....FUSE, TIME LAG (1A)
F901	△ 1-532-286-00	(302ES, UK).....FUSE, TIME LAG (2.5A)
F902	△ 1-532-078-00	(302ES, AEP, G-AEP).....FUSE, TIME LAG (1A)
FLD201	1-519-304-00	INDICATOR TUBE, FLUORESCENT
H151	8-719-800-31	DIODE THS103A-1
H152	8-719-800-31	DIODE THS103A-1
IC151	8-759-600-02	IC CX20109
IC201	8-752-010-80	IC CX20108
IC202	8-759-700-58	IC NJM4558D-FA

The components identified by shading and mark **△** are critical for safety. Replace only with part number specified.

Les composants identifiés par une trame et une marque **△** sont critiques pour la sécurité. Ne les remplacer que par une pièce portant le numéro spécifié.

CDP-302/302ES/520ES

ELECTRICAL PARTS

Ref.No.	Part No.	Description
IC301	8-759-602-25	IC M50760-414P
IC302	8-759-913-84	IC MSM6404A-41RS
IC303	8-759-913-82	IC MSM6404A-39RS
IC304	8-759-202-13	IC TC74HC04P
IC305	8-759-100-82	IC UPC4082C
IC306	8-759-145-58	IC UPC4558C
IC307	8-759-912-52	IC CX23035
IC308	8-759-913-72	IC MB8416-20LPF
IC309	8-759-912-53	IC CX23034
IC310	8-752-015-20	IC CX20152
IC311	8-759-140-53	IC UPD4053BC
IC312	8-759-984-66	IC MB84066B
IC401	8-759-910-75	IC TDB0353DP
IC402	8-759-602-33	IC CX20197
IC403	8-759-602-33	IC CX20197
IC501	8-759-910-75	IC TDB0353DP
IC502	8-759-602-33	IC CX20197
IC503	8-759-602-33	IC CX20197
IC801	8-759-600-35	IC M54940P
IC851	8-752-010-60	IC CX20106
IC901	8-759-700-51	IC NJM7805A
IC902	8-759-700-28	IC NJM7905A
IC903	8-759-170-12	IC UPC78M12H
IC904	8-759-700-24	IC NJM79M12A
IC905	8-759-700-11	IC NJM78M05A
IC906	8-759-700-20	IC NJM79M05A
L51	1-408-563-00	MICRO INDUCTOR 10UH
L301	1-426-212-11	COIL (RF)
L302	1-406-123-11	COIL (OSC)
L303	1-408-597-00	MICRO INDUCTOR 3.3UH
L304	1-408-597-00	MICRO INDUCTOR 3.3UH
L305	1-408-597-00	MICRO INDUCTOR 3.3UH
L601	1-408-117-00	MICRO INDUCTOR 10UH
L901	1-421-580-00	(302,520ES)...TRANSFORMER, POWER
L901	1-421-340-11	(302ES;AEP,G-AEP,UK)...LINE FILTER
M53	1-422-197-13	COIL (DRIVE)
M651	X-4902-019-1	MOTOR ASSY, CHUCKING
M652	A-4608-303-A	MOTOR ASSY, LOADING
PL901	1-518-370-00	(302)...LAMP, PILOT
PT901A	1-448-016-11	(302,520ES)...TRANSFORMER, POWER
PT901A	1-448-017-11	(302ES;E)...TRANSFORMER, POWER
PT901A	1-448-018-11	(302ES;AEP,G-AEP,UK)...TRANSFORMER, POWER
PS301	1-532-685-00	LINK, IC
PS901	1-532-675-00	LINK, IC
PS902	1-532-675-00	LINK, IC

ELECTRICAL PARTS

Ref.No.	Part No.	Description
PS951	1-532-675-00	LINK, IC
PS952	1-532-675-00	LINK, IC
Q151	8-729-177-44	TRANSISTOR 2SD774-5
Q152	8-729-103-43	TRANSISTOR 2SB734-2
Q153	8-729-177-44	TRANSISTOR 2SD774-5
Q154	8-729-103-43	TRANSISTOR 2SB734-2
Q201	8-729-177-44	TRANSISTOR 2SD774-5
Q202	8-729-374-02	TRANSISTOR 2SB740
Q203	8-729-177-44	TRANSISTOR 2SD774-5
Q204	8-729-374-02	TRANSISTOR 2SB740
Q205	8-729-177-44	TRANSISTOR 2SD774-5
Q206	8-729-374-02	TRANSISTOR 2SB740
Q209	8-729-117-54	TRANSISTOR 2SA1175
Q210	8-729-100-13	TRANSISTOR 2SC2001
Q211	8-729-900-74	TRANSISTOR DTC143TS
Q212	8-729-900-74	TRANSISTOR DTC143TS
Q213	8-729-900-89	TRANSISTOR DTC144ES
Q301	8-729-177-44	TRANSISTOR 2SD774-5
Q302	8-729-374-02	TRANSISTOR 2SB740
Q303	8-729-900-81	TRANSISTOR DTC114ES
Q304	8-729-900-81	TRANSISTOR DTC114ES
Q305	8-729-900-81	TRANSISTOR DTC114ES
Q306	8-729-900-81	TRANSISTOR DTC114ES
Q307	8-729-900-62	TRANSISTOR DTA114ES
Q308	8-729-900-81	TRANSISTOR DTC114ES
Q309	8-729-178-55	TRANSISTOR 2SC2785-E
Q310	8-729-900-81	TRANSISTOR DTC114ES
Q401	8-729-800-43	TRANSISTOR 2SK152
Q501	8-729-800-43	TRANSISTOR 2SK152
Q801	8-729-900-46	TRANSISTOR DTC143TF
Q802	8-729-900-46	TRANSISTOR DTC143TF
Q803	8-729-900-46	TRANSISTOR DTC143TF
Q804	8-729-987-42	TRANSISTOR 2SA874
Q901	8-729-177-44	TRANSISTOR 2SD774-5
Q902	8-729-178-55	TRANSISTOR 2SC2785-E
Q903	8-729-178-55	TRANSISTOR 2SC2785-E
Q904	8-729-900-62	TRANSISTOR DTA114ES
Q905	8-729-117-54	TRANSISTOR 2SA1175
Q906	8-729-900-81	TRANSISTOR DTC114ES
R151	1-247-831-00	CARBON 1K 5% 1/6W
R152	1-247-831-00	CARBON 1K 5% 1/6W
R153	1-247-831-00	CARBON 1K 5% 1/6W
R154	1-247-831-00	CARBON 1K 5% 1/6W
R155	1-247-831-00	CARBON 1K 5% 1/6W
R156	1-247-831-00	CARBON 1K 5% 1/6W

The components identified by shading and mark Δ are critical for safety. Replace only with part number specified.

Les composants identifiés par une trame et une marque Δ sont critiques pour la sécurité. Ne les remplacer que par une pièce portant le numéro spécifié.

ELECTRICAL PARTS

Ref.No.	Part No.	Description			
R157	1-247-887-00	CARBON	220K	5%	1/6W
R158	1-247-887-00	CARBON	220K	5%	1/6W
R159	1-247-887-00	CARBON	220K	5%	1/6W
R160	1-247-887-00	CARBON	220K	5%	1/6W
R201	1-247-863-00	CARBON	22K	5%	1/6W
R202	1-247-851-00	CARBON	6.8K	5%	1/6W
R203	1-247-867-00	CARBON	33K	5%	1/6W
R204	1-247-847-00	CARBON	4.7K	5%	1/6W
R205	1-247-819-00	CARBON	330	5%	1/6W
R206	1-247-865-00	CARBON	27K	5%	1/6W
R207	1-247-807-00	CARBON	100	5%	1/6W
R208	1-247-851-00	CARBON	6.8K	5%	1/6W
R209	1-247-864-00	CARBON	24K	5%	1/6W
R210	1-247-851-00	CARBON	6.8K	5%	1/6W
R211	1-247-831-00	CARBON	1K	5%	1/6W
R212	1-247-859-00	CARBON	15K	5%	1/6W
R213	1-247-855-00	CARBON	10K	5%	1/6W
R214	1-247-837-00	CARBON	1.8K	5%	1/6W
R215	1-247-879-00	CARBON	100K	5%	1/6W
R216	1-247-869-00	CARBON	39K	5%	1/6W
R217	1-247-855-00	CARBON	10K	5%	1/6W
R218	1-247-903-00	CARBON	1M	5%	1/6W
R219	1-247-831-00	CARBON	1K	5%	1/6W
R220	1-247-807-00	CARBON	100	5%	1/6W
R221	1-247-863-00	CARBON	22K	5%	1/6W
R222	1-247-857-00	CARBON	12K	5%	1/6W
R223	1-247-841-00	CARBON	2.7K	5%	1/6W
R224	1-247-869-00	CARBON	39K	5%	1/6W
R225	1-247-843-00	CARBON	3.3K	5%	1/6W
R226	1-247-859-00	CARBON	15K	5%	1/6W
R227	1-247-845-00	CARBON	3.9K	5%	1/6W
R228	1-247-815-00	CARBON	220	5%	1/6W
R229	1-247-865-00	CARBON	27K	5%	1/6W
R231	1-247-883-00	CARBON	150K	5%	1/6W
R232	1-247-899-00	CARBON	680K	5%	1/6W
R235	1-247-855-00	CARBON	10K	5%	1/6W
R236	1-247-855-00	CARBON	10K	5%	1/6W
R242	1-247-855-00	CARBON	10K	5%	1/6W
R243	1-247-895-00	CARBON	470K	5%	1/6W
R244	1-247-839-00	CARBON	2.2K	5%	1/6W
R245	1-247-855-00	CARBON	10K	5%	1/6W
R246	1-247-831-00	CARBON	1K	5%	1/6W
R247	1-247-871-00	CARBON	47K	5%	1/6W
R301	1-247-847-00	CARBON	4.7K	5%	1/6W
R302	1-247-841-00	CARBON	2.7K	5%	1/6W

ELECTRICAL PARTS

Ref.No.	Part No.	Description			
R303	1-215-453-00	METAL	22K	1%	1/6W
R304	1-215-453-00	METAL	22K	1%	1/6W
R305	1-247-851-00	CARBON	6.8K	5%	1/6W
R306	1-247-857-00	CARBON	12K	5%	1/6W
R307	1-247-867-00	CARBON	33K	5%	1/6W
R308	1-247-831-00	CARBON	1K	5%	1/6W
R309	1-247-879-00	CARBON	100K	5%	1/6W
R310	1-247-879-00	CARBON	100K	5%	1/6W
R311	1-247-879-00	CARBON	100K	5%	1/6W
R313	1-214-741-00	METAL	3.3K	1%	1/4W
R314	1-214-745-00	METAL	4.7K	1%	1/4W
R315	1-214-769-00	METAL	47K	1%	1/4W
R316	1-214-745-00	METAL	4.7K	1%	1/4W
R317	1-247-855-00	CARBON	10K	5%	1/6W
R318	1-247-855-00	CARBON	10K	5%	1/6W
R319	1-247-903-00	CARBON	1M	5%	1/6W
R320	1-247-843-00	CARBON	3.3K	5%	1/6W
R321	1-247-871-00	CARBON	47K	5%	1/6W
R322	1-247-855-00	CARBON	10K	5%	1/6W
R323	1-247-855-00	CARBON	10K	5%	1/6W
R324	1-247-855-00	CARBON	10K	5%	1/6W
R325	1-247-863-00	CARBON	22K	5%	1/6W
R326	1-247-863-00	CARBON	22K	5%	1/6W
R327	1-247-855-00	CARBON	10K	5%	1/6W
R351	1-215-441-00	METAL	6.8K	1%	1/6W
R352	1-215-441-00	METAL	6.8K	1%	1/6W
R353	1-247-903-00	CARBON	1M	5%	1/6W
R354	1-247-856-00	CARBON	11K	5%	1/6W
R355	1-247-856-00	CARBON	11K	5%	1/6W
R357	1-247-863-00	CARBON	22K	5%	1/6W
R358	1-247-843-00	CARBON	3.3K	5%	1/6W
R359	1-247-869-00	CARBON	39K	5%	1/6W
R360	1-215-453-00	METAL	22K	1%	1/6W
R361	1-247-815-00	CARBON	220	5%	1/6W
R362	1-247-815-00	CARBON	220	5%	1/6W
R363	1-247-887-00	CARBON	220K	5%	1/6W
R365	1-247-851-00	CARBON	6.8K	5%	1/6W
R366	1-247-807-00	CARBON	100	5%	1/6W
R367	1-215-449-00	METAL	15K	1%	1/6W
R368	1-247-807-00	CARBON	100	5%	1/6W
R401	1-214-733-00	METAL	1.5K	1%	1/4W
R402	1-214-742-00	METAL	3.6K	1%	1/4W
R403	1-214-759-00	METAL	18K	1%	1/4W
R404	1-214-745-00	METAL	4.7K	1%	1/4W
R405	1-214-741-00	METAL	3.3K	1%	1/4W

CDP-302/302ES/520ES

ELECTRICAL PARTS

Ref.No.	Part No.	Description			
R406	1-214-737-00	METAL	2.2K	1%	1/4W
R407	1-214-737-00	METAL	2.2K	1%	1/4W
R408	1-214-737-00	METAL	2.2K	1%	1/4W
R409	1-214-737-00	METAL	2.2K	1%	1/4W
R410	1-214-738-00	METAL	2.4K	1%	1/4W
R411	1-214-738-00	METAL	2.4K	1%	1/4W
R412	1-214-742-00	METAL	3.6K	1%	1/4W
R413	1-214-731-00	METAL	1.2K	1%	1/4W
R414	1-214-964-00	METAL	1M	1%	1/4W
R415	1-214-742-00	METAL	3.6K	1%	1/4W
R416	1-214-743-00	METAL	3.9K	1%	1/4W
R417	1-214-777-00	METAL	100K	1%	1/4W
R418	1-214-705-00	METAL	100	1%	1/4W
R419	1-214-761-00	METAL	22K	1%	1/4W
R420	1-214-717-00	METAL	330	1%	1/4W
R421	1-247-815-00	CARBON	220	5%	1/6W
R431	1-247-823-00	CARBON	470	5%	1/6W
R432	1-247-831-00	CARBON	1K	5%	1/6W
R433	1-247-847-00	CARBON	4.7K	5%	1/6W
R434	1-247-867-00	CARBON	33K	5%	1/6W
R435	1-247-815-00	CARBON	220	5%	1/6W
R501	1-214-733-00	METAL	1.5K	1%	1/4W
R502	1-214-742-00	METAL	3.6K	1%	1/4W
R503	1-214-759-00	METAL	18K	1%	1/4W
R504	1-214-745-00	METAL	4.7K	1%	1/4W
R505	1-214-741-00	METAL	3.3K	1%	1/4W
R506	1-214-737-00	METAL	2.2K	1%	1/4W
R507	1-214-737-00	METAL	2.2K	1%	1/4W
R508	1-214-737-00	METAL	2.2K	1%	1/4W
R509	1-214-737-00	METAL	2.2K	1%	1/4W
R510	1-214-738-00	METAL	2.4K	1%	1/4W
R511	1-214-738-00	METAL	2.4K	1%	1/4W
R512	1-214-742-00	METAL	3.6K	1%	1/4W
R513	1-214-731-00	METAL	1.2K	1%	1/4W
R514	1-214-964-00	METAL	1M	1%	1/4W
R515	1-214-742-00	METAL	3.6K	1%	1/4W
R516	1-214-743-00	METAL	3.9K	1%	1/4W
R517	1-214-777-00	METAL	100K	1%	1/4W
R518	1-214-705-00	METAL	100	1%	1/4W
R519	1-214-761-00	METAL	22K	1%	1/4W
R520	1-214-717-00	METAL	330	1%	1/4W
R521	1-247-815-00	CARBON	220	5%	1/6W
R531	1-247-823-00	CARBON	470	5%	1/6W
R532	1-247-831-00	CARBON	1K	5%	1/6W
R533	1-247-847-00	CARBON	4.7K	5%	1/6W

ELECTRICAL PARTS

Ref.No.	Part No.	Description			
R534	1-247-867-00	CARBON	33K	5%	1/6W
R535	1-247-815-00	CARBON	220	5%	1/6W
R601	1-247-881-00	CARBON	120K	5%	1/6W
R602	1-247-881-00	CARBON	120K	5%	1/6W
R603	1-247-885-00	CARBON	180K	5%	1/6W
R604	1-247-885-00	CARBON	180K	5%	1/6W
R605	1-247-815-00	CARBON	220	5%	1/6W
R701	1-247-783-00	CARBON	10	5%	1/6W
R702	1-247-783-00	CARBON	10	5%	1/6W
R801	1-247-111-00	CARBON	150	5%	1/4W
R802	1-247-119-00	CARBON	330	5%	1/4W
R803	1-247-111-00	CARBON	150	5%	1/4W
R804	1-247-111-00	CARBON	150	5%	1/4W
R851	1-247-775-00	CARBON	4.7	5%	1/6W
R852	1-214-784-00	METAL	200K	1%	1/4W
R853	1-247-863-00	CARBON	22K	5%	1/6W
R854	1-247-799-00	CARBON	47	5%	1/6W
R901	1-212-865-00	FUSE	22	5%	1/4W
R911	1-212-857-00	FUSE	10	5%	1/4W
R912	1-247-839-00	CARBON	2.2K	5%	1/6W
R913	1-244-837-00	CARBON	33	5%	1/2W
R961	1-247-855-00	CARBON	10K	5%	1/6W
R962	1-247-859-00	CARBON	15K	5%	1/6W
R963	1-247-881-00	CARBON	120K	5%	1/6W
R964	1-247-855-00	CARBON	10K	5%	1/6W
R965	1-247-847-00	CARBON	4.7K	5%	1/6W
RV201	1-226-773-00	RES, ADJ, METAL GLAZE	22K		
RV202	1-226-703-00	RES, ADJ, METAL GLAZE	10K		
RV301	1-226-772-00	RES, ADJ, METAL GLAZE	4.7K		
RV401	1-230-313-00	RES, VAR, CARBON 20K/20K,	LEVEL		
RV501	1-230-313-00	RES, VAR, CARBON 20K/20K,	LEVEL		
RY901	1-515-529-11	RELAY			
S651	1-554-205-00	SWITCH, PUSH			
S652	1-554-205-00	SWITCH, PUSH			
S653	1-553-636-00	SWITCH, MICRO			
S654	1-553-636-00	SWITCH, MICRO			
S655	1-554-205-00	SWITCH, PUSH			
S656	1-554-205-00	SWITCH, PUSH			
S801	1-553-856-00	SWITCH, KEY BOARD, PLAY			
S802	1-553-856-00	SWITCH, KEY BOARD, PAUSE			
S803	1-553-856-00	SWITCH, KEY BOARD, STOP			
S804	1-553-856-00	SWITCH, KEY BOARD, OPEN			
S805	1-553-856-00	SWITCH, KEY BOARD, CLEAR			
S806	1-553-856-00	SWITCH, KEY BOARD, ◀◀			

The components identified by shading and mark  are critical for safety. Replace only with part number specified.

Les composants identifiés par une trame et une marque  sont critiques pour la sécurité. Ne les remplacer que par une pièce portant le numéro spécifié.

CDP-302/302ES/520ES

ELECTRICAL PARTS

Ref.No.	Part No.	Description
S807	1-553-856-00	SWITCH, KEY BOARD, ►►
S808	1-553-856-00	SWITCH, KEY BOARD, START
S809	1-553-856-00	SWITCH, KEY BOARD, ◀◀
S810	1-553-856-00	SWITCH, KEY BOARD, ►►, ◀◀
S811	1-553-856-00	SWITCH, KEY BOARD, ←
S812	1-553-856-00	SWITCH, KEY BOARD, →
S813	1-553-856-00	SWITCH, KEY BOARD, A↔B
S814	1-553-856-00	SWITCH, KEY BOARD, 1/ALL
S815	1-553-856-00	SWITCH, KEY BOARD, SET
S816	1-553-856-00	SWITCH, KEY BOARD, TIME
S901	1-553-318-00	SWITCH, PUSH (AC POWER) (1 KEY), POWER
SE51	1-422-198-11	COIL (SENSOR)
TB901	*1-535-121-00	TERMINAL
VS901	1-552-963-00	(302ES;E)...SWITCH POWER/VOLTAGE SELECT
X301	1-527-532-00	OSCILLATOR, CERAMIC
X302	1-567-336-11	VIBRATOR, CRYSTAL

ACCESSORY & PACKING MATERIAL

No.	Part No.	Description
701	A-4600-438-A	COMMANDER COMPLETE ASSY (RM-D902)
702	1-551-315-11	(302ES,520ES)..CORD, CONNECTION (RK-112)
702	1-551-734-11	(302)...CORD, CONNECTION (RK-74A)
703	1-564-085-00	(302ES;UK)...PLUG, AC (CM-35)
704	1-556-372-41	CORD, CONNECTION (4 CORE)
705	3-701-630-00	BAG, POLYETHYLENE
706	3-703-390-01	(302,520ES)...INSTRUCTION
706	3-795-629-14	(302ES;AEP)...INSTRUCTION
707	3-760-149-11	(302ES)...MANUAL, INSTRUCTION
707	3-760-149-21	(302).....MANUAL, INSTRUCTION
707	3-760-149-31	(302; Canadian)...MANUAL, INSTRUCTION
707	3-760-149-41	(302ES;AEP,G-AEP)...MANUAL, INSTRUCTION
707	3-760-402-21	(520ES)...MANUAL, INSTRUCTION
708	4-884-695-03	CLEANER, DISK
709	4-907-610-01	JOINT
710	3-304-973-00	SHEET, PROTECTION
711	4-908-440-11	(302).....INDIVIDUAL CARTON
711	4-908-440-21	(302ES)...INDIVIDUAL CARTON
711	4-908-440-31	(520ES)...INDIVIDUAL CARTON
712	4-908-441-01	CUSHION (RIGHT), UPPER
713	4-908-442-01	CUSHION (LEFT), UPPER
714	4-908-443-01	CUSHION, LOWER
715	4-908-602-01	HOLDER, COMMANDER

The components identified by shading and mark  are critical for safety. Replace only with part number specified.

Les composants identifiés par une trame et une marque  sont critiques pour la sécurité. Ne les remplacer que par une pièce portant le numéro spécifié.