

CDP-270/470

SERVICE MANUAL

US Model
Canadian Model
AEP Model
E Model
 CDP-270

US Model
Canadian Model
AEP Model
UK Model
E Model
 CDP-470

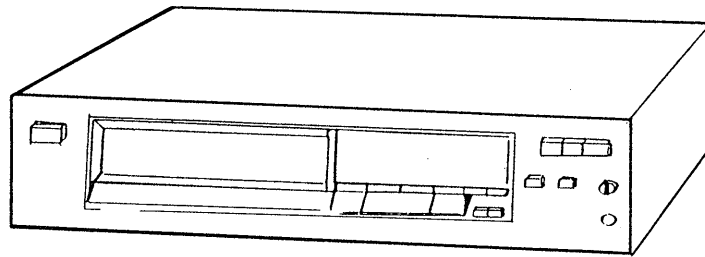

SPECIFICATIONS

Frequency response	2Hz—20kHz (±1 dB)
Signal-to-noise ratio	More than 100dB
Dynamic range	More than 90dB
Harmonic distortion (1 kHz)	Less than 0.09%
Channel separation	More than 95 dB (1 kHz)
Outputs	LINE OUT (photo jacks) Output level 2V (at 50kilohms) Load impedance over 10kilohms
General	
Power requirements	US, Canadian model: 120V AC, 60Hz AEP model: 220V AC, 50/60Hz UK model: 240V AC, 50/60Hz E model: 110—120V or 220—240V AC adjustable, 50/60Hz
Power consumption	US, Canadian model: 12W EXCEPT US, Canadian model: 10W
Dimensions (approx. including projections)	AEP, UK model: 430x100x275 mm (17x4x10 inches) EXCEPT AEP, UK model: 430x95x275 mm (17x3¾x10 inches)
Weight (approx.)	3.5kg (7 lbs 12oz)

TABLE OF CONTENTS

<u>Section</u>	<u>Title</u>	<u>Page</u>
	Specifications	1
	Features	2
	Safety Check-out	2
	Servicing Note	3
SECTION 1. GENERAL		
1-1.	Location and Function of Controls.	4
1-2.	Description on IC6 (MSC6458).	5
SECTION 2. ADJUSTMENTS		7
SECTION 3. DIAGRAMS		
3-1.	Semiconductor Lead Layouts	10
3-2.	Printed Wiring Boards	11
3-3.	Schematic Diagram	13
3-4.	IC Block Diagrams	16
3-5.	Waveforms	17
SECTION 4. EXPLODED VIEWS		18
SECTION 5. ELECTRICAL PARTS LIST		21
SUPPLEMENT-1		25

COMPACT DISC PLAYER
SONY®

FEATURES

- Three CUSTOM EDIT functions, convenient for tape editing
 - PROGRAM EDIT function for confirming the total playing time while choosing the selection to be programmed.
 - TIME EDIT function for programming selections automatically to fit in a desired duration.
 - TIME FADE function for stopping the play, fading out at the desired time.
- FADE-IN/FADE-OUT function for fading in or out the play when starting or stopping.
- SHUFFLE play for playing the selections in a random order.
- REPEAT function for a single selection, the whole disc, PROGRAM play, or SHUFFLE play.
- Easy-to-read display window shows the selection number being played, all the numbers of the selections on the disc (up to 16), the elapsed playing time, and the remaining time.

SAFETY-RELATED COMPONENT WARNING!!

COMPONENTS IDENTIFIED BY MARK \triangle OR DOTTED LINE WITH MARK \triangle ON THE SCHEMATIC DIAGRAMS AND IN THE PARTS LIST ARE CRITICAL TO SAFE OPERATION. REPLACE THESE COMPONENTS WITH SONY PARTS WHOSE PART NUMBERS APPEAR AS SHOWN IN THIS MANUAL OR IN SUPPLEMENTS PUBLISHED BY SONY.

ATTENTION AU COMPOSANT AYANT RAPPORT À LA SÉCURITÉ!

LES COMPOSANTS IDENTIFIÉS PAR UNE MARQUE \triangle SUR LES DIAGRAMMES SCHÉMATIQUES ET LA LISTE DES PIÈCES SONT CRITIQUES POUR LA SÉCURITÉ DE FONCTIONNEMENT. NE REMPLACER CES COMPOSANTS QUE PAR DES PIÈCES SONY DONT LES NUMÉROS SONT DONNÉS DANS CE MANUEL OU DANS LES SUPPLÉMENTS PUBLIÉS PAR SONY.

SAFETY CHECK-OUT

After correcting the original service problem, perform the following safety check before releasing the set to the customer:

Check the antenna terminals, metal trim, "metallized" knobs, screws, and all other exposed metal parts for AC leakage. Check leakage as described below.

LEAKAGE TEST

The AC leakage from any exposed metal part to earth ground and from all exposed metal parts to any exposed metal part having a return to chassis, must not exceed 0.5 mA (500 microamperes). Leakage current can be measured by any one of three methods.

1. A commercial leakage tester, such as the Simpson 229 or RCA WT-540A. Follow the manufacturers' instructions to use these instruments.
2. A battery-operated AC milliammeter. The Data Precision 245 digital multimeter is suitable for this job.
3. Measuring the voltage drop across a resistor by means of a VOM or battery-operated AC voltmeter. The "limit" indication is 0.75 V, so analog meters must have an accurate low-voltage scale. The Simpson 250 and Sanwa SH-63Trd are examples of a passive VOM that is suitable. Nearly all battery operated digital multimeters that have a 2 V AC range are suitable. (See Fig. A)

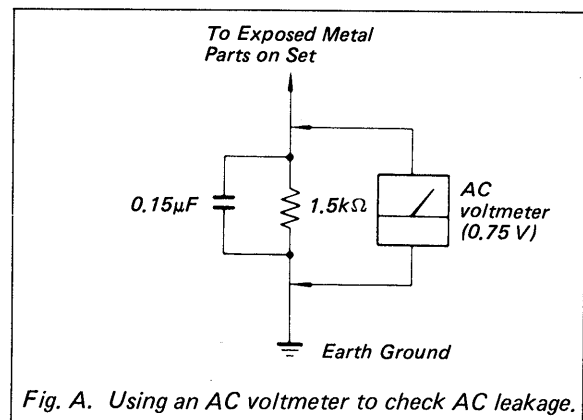

Fig. A. Using an AC voltmeter to check AC leakage.

SERVICING NOTE**PROTECTION OF EYES FROM LASER BEAM DURING SERVICING**

This set employs a laser. Therefore, be sure to follow carefully the instructions below when servicing.

CAUTION

Use of controls or adjustments or performance of procedures other than those specified herein may result in hazardous radiation exposure.

NOTES ON HANDLING THE OPTICAL PICK-UP BLOCK OR BASE UNIT

The laser diode in the optical pick-up block may suffer electrostatic breakdown because of the potential difference generated by the charged electrostatic load, etc. on clothing and the human body.

During repair, pay attention to electrostatic breakdown and also use the procedure in the printed matter which is included in the repair parts.

The flexible board is easily damaged and should be handled with care.

1. Laser Diode Properties

- Material: GaAlAs
- Wavelength: 780 nm
- Emission Duration: continuous
- Laser Output: max. 44.6 μ W*

* This output is the value measured at a distance of about 200 mm from the objective lens surface on the Optical Pick-up Block.

2. During service, do not take the Optical Pick-up Block apart, and do not adjust the APC circuit. If there is a breakdown in the APC circuit (including laser diode), replace the entire Optical Pick-up Block (including APC board).

BESKYTTELSE AF ØJNE MOD LASERSTRÅLING UNDER SERVICE

I dette apparat anvendes laserlys. Derfor skal nedenstående instruktioner nøje følges under service.

Følg iøvrigt instruktionerne i servicemanualen.

ADVARSEL!!

Under service må øjnene ikke komme nær objektiv-linsen på den optiske pick-up enhed. I tilfælde af at det er nødvendigt at kontrollere udsendelsen af laserlys, skal det ske i en afstand af mere end 25 cm fra den optiske pick-up.

LASER ADVARSEL MÆRKNING

Følgende mærkning findes indvendig i apparatet:

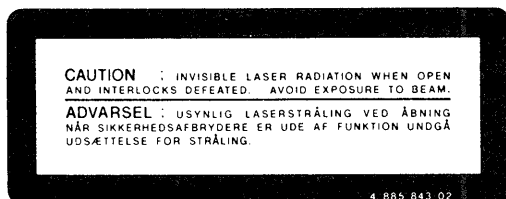
1. Advarsel Mærkning**1. Laser-didoe data**

- Materiale: GaAlAs
- Bølgelængde: 780 nm
- Udstråling: Kontinuerlig
- Laseroutput: Max. 0,4 mW*

* Målt i 1,6 mm afstand fra overfladen af objektiv-linsen på den optiske pick-up enhed.

- Klassifikation: Klasse IIIb.

2. Adskil aldrig den optiske pick-up enhed under service, og juster ikke APC kredsløbet (Automatic Power Control). Hvis APC kredsløbet (incl. laserdioden) bryder ned, skal hele den optiske pick-up enhed (incl. APC printkortet) udskiftes.

VAROITUS: Laite sisältää, laserdiodin, joka lähettää (näkyvätöntä) silmille vaarallista lasersäteilyä.

SECTION 1 GENERAL

1-1. LOCATION AND FUNCTION OF CONTROLS

Front Panel

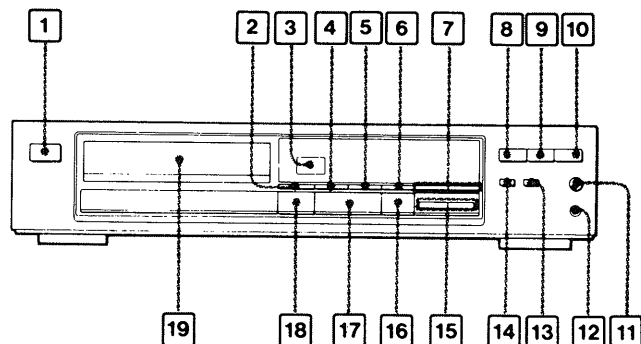

- 1 POWER switch
- 2 TIME button
- 3 Remote control sensor
- 4 AUTO SPACE button
- 5 REPEAT button
- 6 EDIT/TIME FADE button
- 7 ◀▶▶▶ (manual search) buttons
- 8 PROGRAM (or PGM) button
- 9 SHUFFLE button
- 10 CONTINUE button
- 11 PHONE LEVEL (headphones level) control
- 12 PHONES jack

Remote Commander (supplied only for the CDP-470)

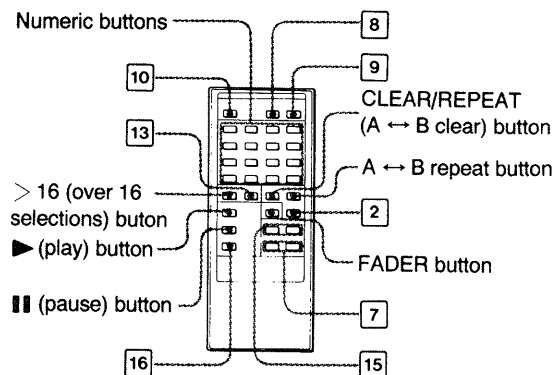

- 13 CLEAR (program clear) button
- 14 PGM CHECK (program check) button
- 15 ◀▶▶▶ (AMS*/RMS**) buttons
- 16 ■ (stop) button
- 17 ▶|| (play/pause) button
- 18 ▲ (OPEN/CLOSE) button
- 19 Disc compartment

*AMS is the abbreviation of Automatic Music Sensor.
**RMS is the abbreviation of Random Music Sensor.

Remote Control Operation

Once the POWER switch is turned on, you can remotely control various functions of the player with the remote commander. (Supplied only with the CDP-470).

Operations which performed only with the remote commander

- Direct music selection.
- A ↔ B repeat.
- Fading in/Fading out the play.

Operations which cannot be performed with the remote commander

- Turning the power on and off.
- Opening and closing the disc compartment.
- Setting and releasing auto space function.
- Checking the programmed selections.
- Time edit function.
- Time fade function.

Notes on the remote commander and remote control operation

- Keep the commander away from extremely hot or humid places.
- Avoid dropping any foreign objects into the commander casing, particularly when replacing the batteries.
- To avoid a malfunction, do not simultaneously depress two or more buttons.
- Avoid exposure of the remote sensor to direct sunlight or lighting apparatus. Such exposure can cause a malfunction.

1-2. DESCRIPTION ON IC6 (MSC6458) SYSTEM CONTROL MICROCOMPUTER

IC6 has the following functions:

- . Digital signal output to operation key
- . Sub Q signal loading and processing
- . Fluorescent display (FLD) control
- . Servo circuit control

Pin Functions

Pin no.	Pin name	I/O	Description
1	PLL SW	O	"L" in play mode and "H" in search mode.
2	CLK	O	Command transfer of clock to SSP (IC3) and DSP (IC7).
3	DATA	O	Command transfer of data to SSP (IC3) and DSP (IC7).
4	XLK	O	Command transfer of latch to SSP (IC3) and DSP (IC7).
5	PRGL	O	Command transfer of latch to DFIL (IC9).
6	SYNC OUT	O	No connector (NC).
7	SENSE	I	SSP (IC2) and DSP (IC3) sense information.
8	SYNC ON	I	Sync REC ("L" in REC mode).
9	SIRCS	I	Remote control signal input.
10	SCOR	I	Q code read timing.
11	AF ADJ	I	No connection (NC).
12	ADJ	I	"L" in adjustment mode.
13	AMUTE	O	ALL muting. Output to DSP (IC3) MUTG.
14	EMPS	O	No connection (NC)
15	SUBQ	I	Subcode data.
16	SQCLK	O	Subcode data read clock.
17	GFS	I	"H" when CLV is locked.
18	FOK	I	"H" when focus is on.
19	KEY0	I	Key matrix input, "H" active.
20	KEY1	I	Key matrix input, "H" active.
21	KEY2	I	Key matrix input, "H" active.
22	KEY3	I	Key matrix input, "H" active.
23	KEY4	I	Key matrix input, "H" active.
24	KEY5	I	Key matrix input, "H" active.
25	INSW	I	Loading IN SW.
26	LDON	O	Laser on / off.
27	OUTSW	I/O	Loading OUT SW.
28	LODOUT	O	Loading motor control.
29	LODIN	O	Loading motor control.
30	OSC1	I	Oscillator input terminal (4 MHz).
31	OSC0	I	Oscillator input terminal (4 MHz).

Pin No.	Pin name	I/O	Description
32	GND	—	GND terminal.
33	RESET	I	Reset input terminal. Input when power is turned on.
34	TEST	—	No connection (NC).
35	VL DOWN	—	No connection (NC).
36	VL UP	O	Volume up.
37	TIMER	O	No connection (NC).
38	LED	O	Volume indicator.
39	8G	O	FLD timing output.
40	7G	O	FLD timing output.
41	6G	O	FLD timing output.
42	5G	O	FLD timing output.
43	4G	O	FLD timing output.
44	3G	O	FLD timing output.
45	2G	O	FLD timing output.
46	1G	O	FLD timing output.
47	NC	—	No connection (NC).
48	o	O	FLD segment output.
49	n	O	FLD segment output.
50	m	O	FLD segment output.
51	+ 30V	—	+ 30V
52	l	O	FLD segment output.
53	k	O	FLD segment output.
54	j	O	FLD segment output.
55	i	O	FLD segment output.
56	h	O	FLD segment output.
57	g	O	FLD segment output.
58	f	O	FLD segment output.
59	e	O	FLD segment output.
60	d	O	FLD segment output.
61	c	O	FLD segment output.
62	b	O	FLD segment output.
63	a	O	FLD segment output.
64	VDD	—	positive(+) power supply (5V)

SECTION 2 ADJUSTMENTS

ELECTRICAL ADJUSTMENTS

1. Perform adjustments in the order given.
2. Use YEDS-18 (Part No. 3-702-101-01) disc unless otherwise indicated.
3. Use the oscilloscope with more than $10M\Omega$ impedance.

RF PLL Frequency Adjustment/Lock Frequency Check

Procedure:

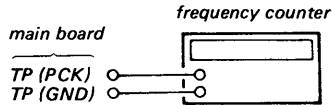

1. Ground test point TP (ASY).
2. Connect the frequency counter to the test points TP (PCK) and TP (GND).
3. Turn POWER switch on.
4. Adjust RV205 so that the reading on the frequency counter is 4.3218 MHz.
... (RF PLL frequency adjustment)
5. Remove the grounding wire from TP (ASY).
6. Put the disc (YEDS-18) in and press \triangleright button.
7. Confirm that the reading on the frequency counter is locked at 4.3218 MHz.

Focus Bias Adjustment

This adjustment should be made after replacing the Optical Pick-up Block.

Procedure:

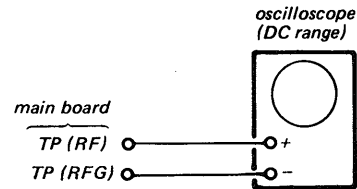

1. Connect oscilloscope to the test points TP (RF) and TP (RFG).
2. Turn POWER switch on.
3. Put the disc (YEDS-18) in and press \triangleright button.
4. Adjust RV202 for an optimum waveform eye pattern. Optimum eye pattern means that shape "◇" can be clearly distinguished at the center of the waveform.

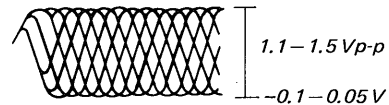

E-F Balance Adjustment

This adjustment should be made after replacing the Optical Pick-up Block.

Procedure:

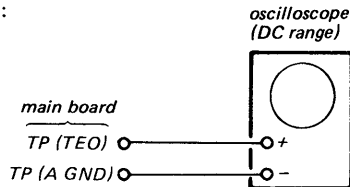

1. Connect the oscilloscope to the test points TP (TEO) and TP (A GND).
2. Ground TP (ADJ) to set an adjustment mode.
3. Turn POWER switch on.
4. Put the disc (YEDS-18) in and press \triangleright button.
5. Adjust RV201 so that the traverse waveform is symmetrical above and below.
6. After adjustment, cancel the adjustment mode.

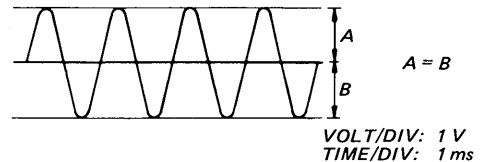

Focus/Tracking Gain Adjustment

A frequency response analyzer is necessary in order to perform this adjustment exactly.

However, this gain has a margin, so even if it is slightly off, there is no problem. Therefore, this adjustment is not recommended generally to be performed.

Focus/tracking gains determine the pick-up follow-up (vertical and horizontal) relative to mechanical noise and mechanical shock when the 2-axis device operate.

However, as these reciprocate, the adjustment is at the point where both are satisfied.

- When gain is raised, the noise when the 2-axis device operates increases.
- When gain is lowered, it is more susceptible to mechanical shock and skipping occurs more easily.
- When gain adjustment is off, the symptoms below appear.

Symptoms	Gain	Focus	Tracking
• The time until music starts becomes longer for STOP → ▷PLAY or automatic selection (◀▶▶▶ buttons pressed). (Normally takes about 2 seconds.)		low	low or high
• Music does not start and disc continues to rotate for STOP → ▷PLAY or automatic selection (◀▶▶▶ buttons pressed.)		-	low
• Disc table opens shortly after STOP → ▷PLAY.		low or high	-
• Sound is interrupted during PLAY. Or time counter display stops progressing.		-	low
• More poise during 2-axis device operation.		high	high

The following is a simple adjustment method.

- Simple Adjustment -

Note: Since exact adjustment cannot be performed, remember the positions of the controls before performing the adjustment. If the positions after the simple adjustment are only a little different, return the controls to the original position.

Procedure:

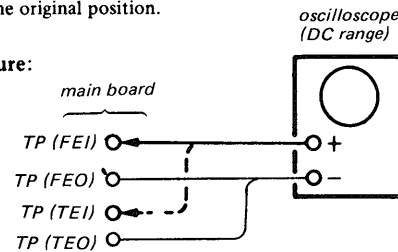

1. Keep the set flat.
If the set is not horizontal, this adjustment cannot be performed due to the gravity against the 2 axis device.
2. Insert the disc (YEDS-18) and press ▷ PLAY button.
3. Connect the oscilloscope to TP (FEI) and TP (FEO).
4. Adjustment RV203 so that the waveform is as shown in the picture below. (focus gain adjustment)

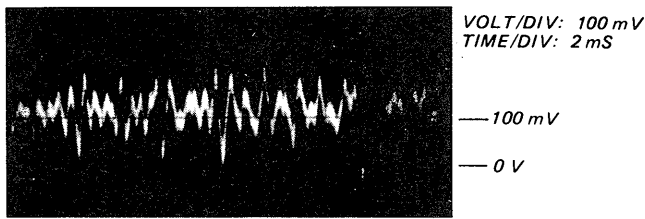

• Incorrect Examples (DC level is quite different from the adjusted waveform) (below)

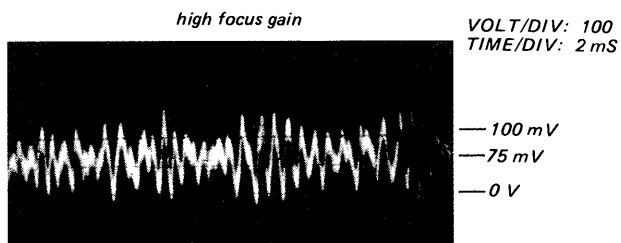
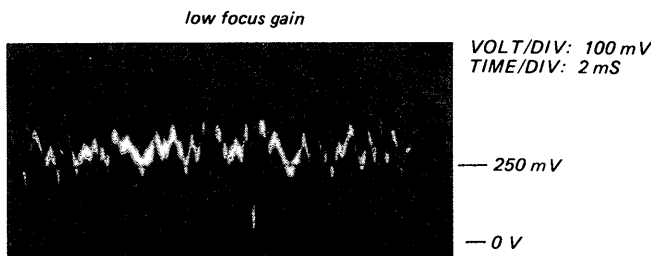

5. Connect the oscilloscope to TP (TEI), TP (TEO).

6. Adjust RV204 so that the waveform is as shown in the picture below. (tracking gain adjustment)

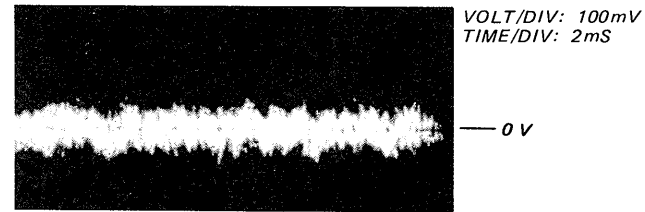

• Incorrect Examples (fundamental wave appears)

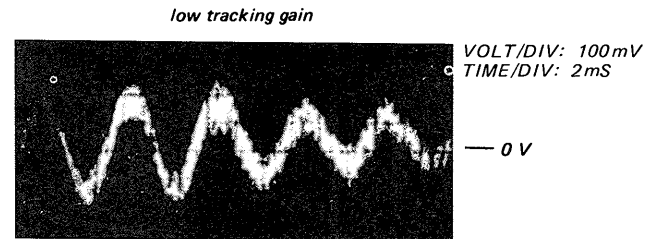

high tracking gain
(higher frequency of the fundamental wave than above)

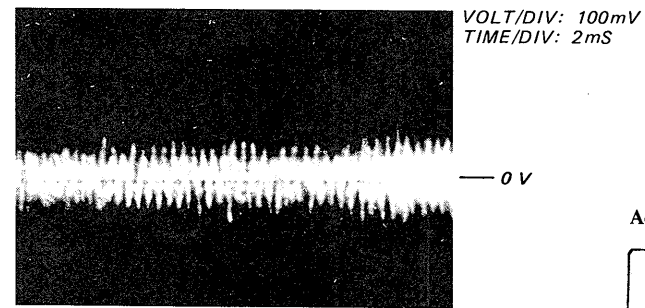

Adjustment Location: main board

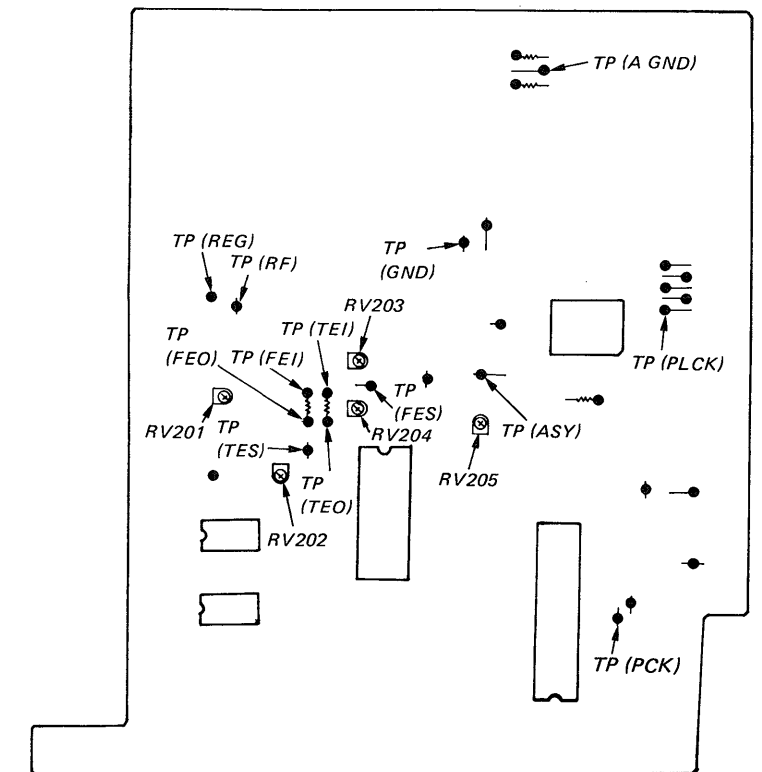

- Component Side -

SECTION 3
DIAGRAMS

3-1. SEMICONDUCTOR LEAD LAYOUTS

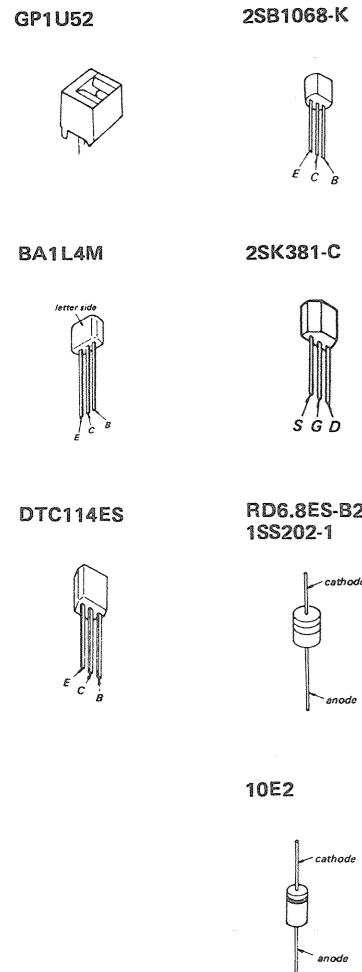

● SEMICONDUCTOR LOCATION

Ref. No.	Location	Ref. No.	Location
D1	E-10	IC6	I-5
D3	J-9	IC7	E-4
D4	J-9	IC8	D-5
D5	J-9	IC9	D-3
D6	D-7	IC10	C-3
D7	D-7	IC11	B-4
D8	D-8	IC12	C-7
D9	D-8	IC13	J-12
D10	C-7	-	-
-	-	Q1	B-7
IC1	C-6	Q2	G-9
IC2	F-8	Q3	G-6
IC3	H-7	Q4	G-5
IC4	H-9	Q5	H-5
IC5	I-9	Q6	H-3

- : parts extracted from the component side.
- : parts extracted from the conductor side.
- : Jumper wire connected to the ground pattern on the component side.

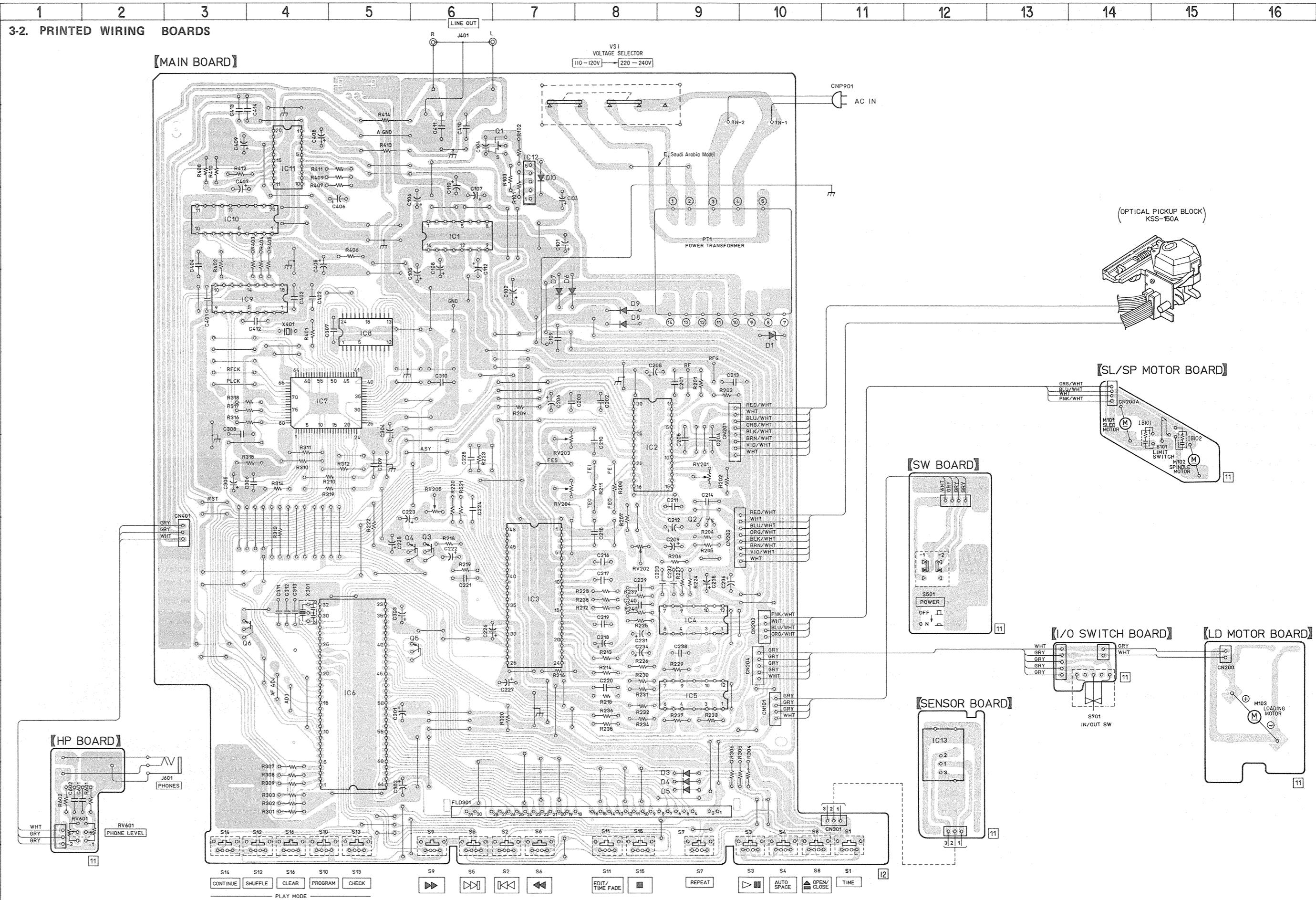

3-3. SCHEMATIC DIAGRAM

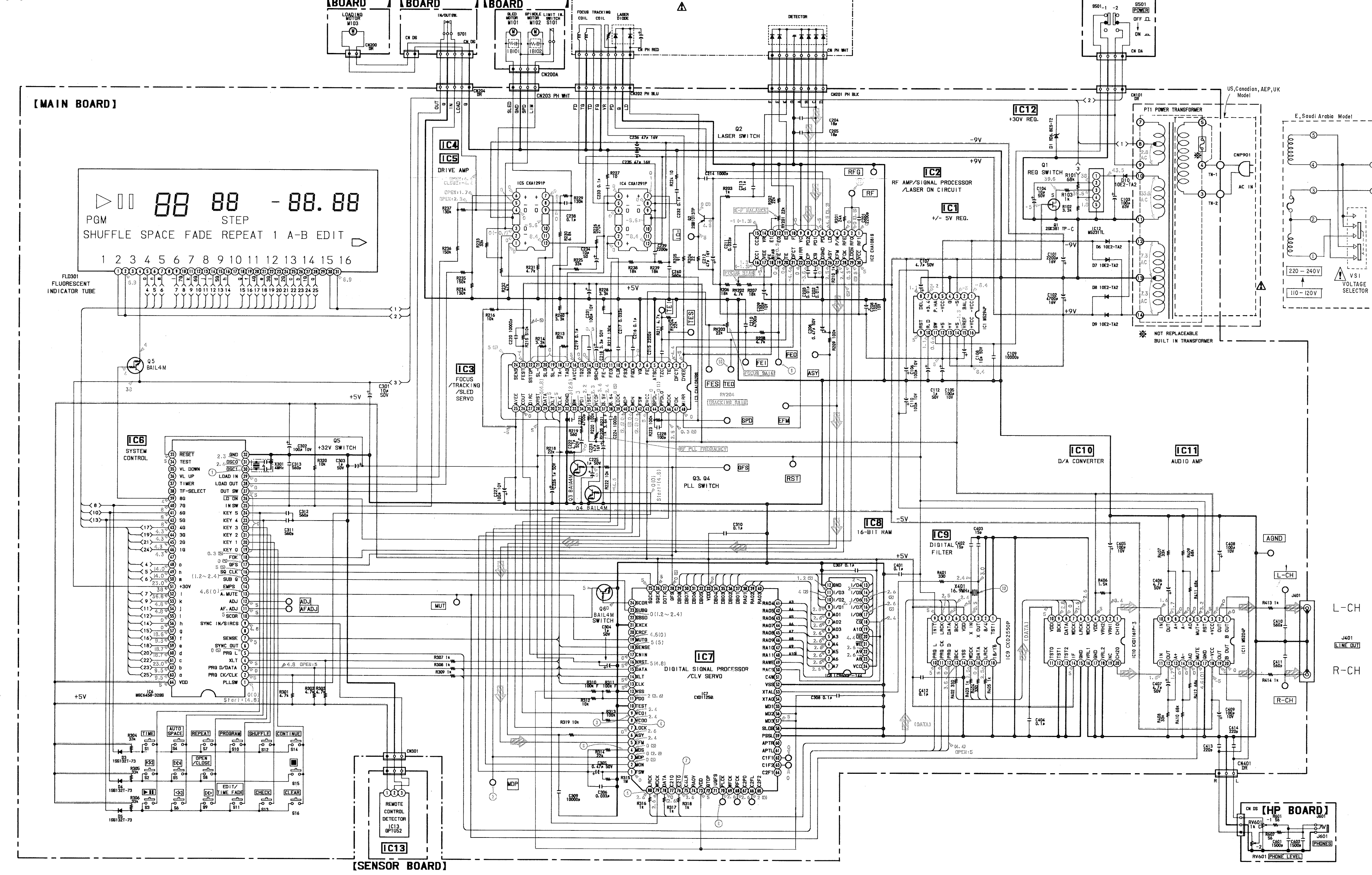

A
B
C
D
E
F
G
H
I
J
K
L
M
N
O

1 2 3 4 5 6 7 8 9 10 11 12 13 14 15 16 17 18 19 20 21 22 23 24

US, Canadian, AEP, UK Model

E, Saudi Arabia Model

220-240V
110-120V
V1
VOLTAGE SELECTOR

NOT REPLACEABLE
BUILT IN TRANSFORMER

L-CH
J401
LINE OUT

R-CH

[HP BOARD]
RV601 (PHONE LEVEL)

3-4. IC BLOCK DIAGRAMS

IC2 CXA1081S

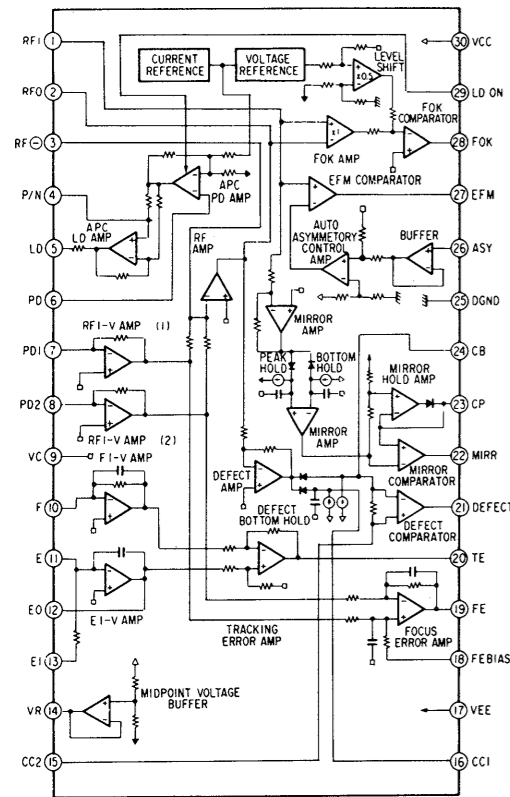

IC8 CXK5816M-12L

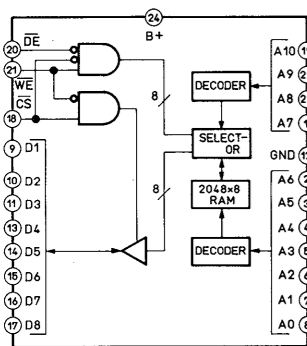

IC3 CXA1082BS

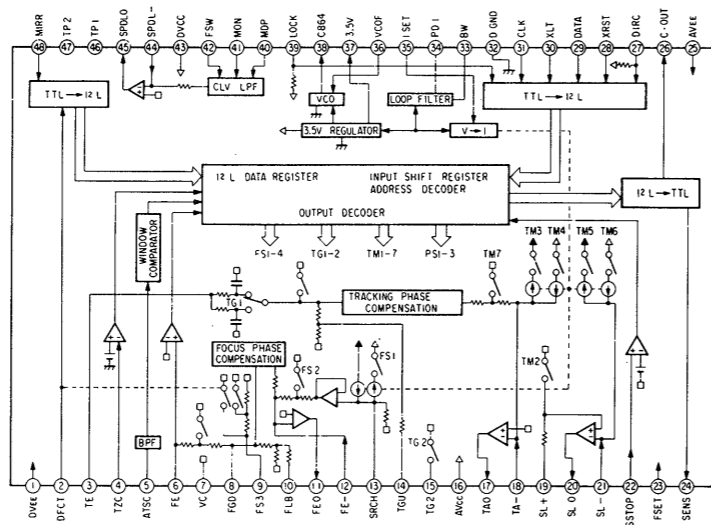

IC9 CXD2550P

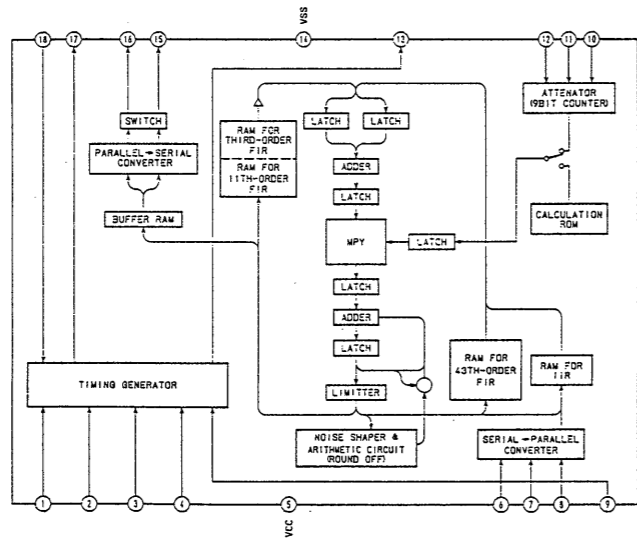

IC4, 5 CXA1291P

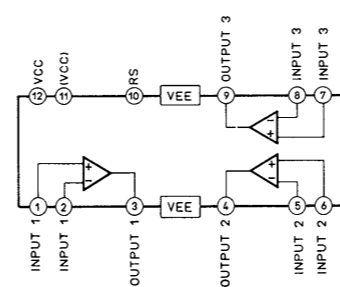

IC12 M5231TL

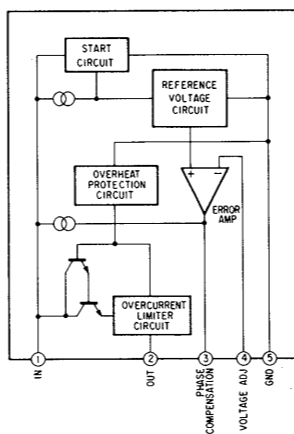

IC10 CXD1161P-3

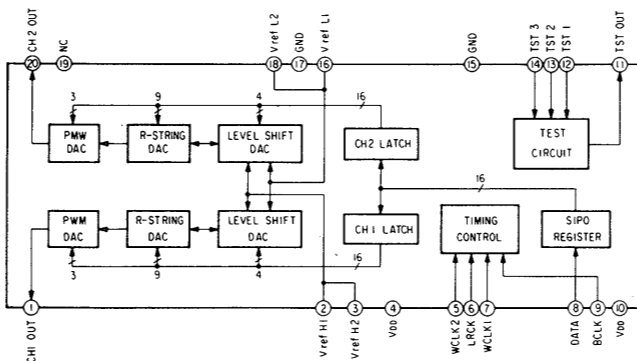

3-5. WAVEFORMS

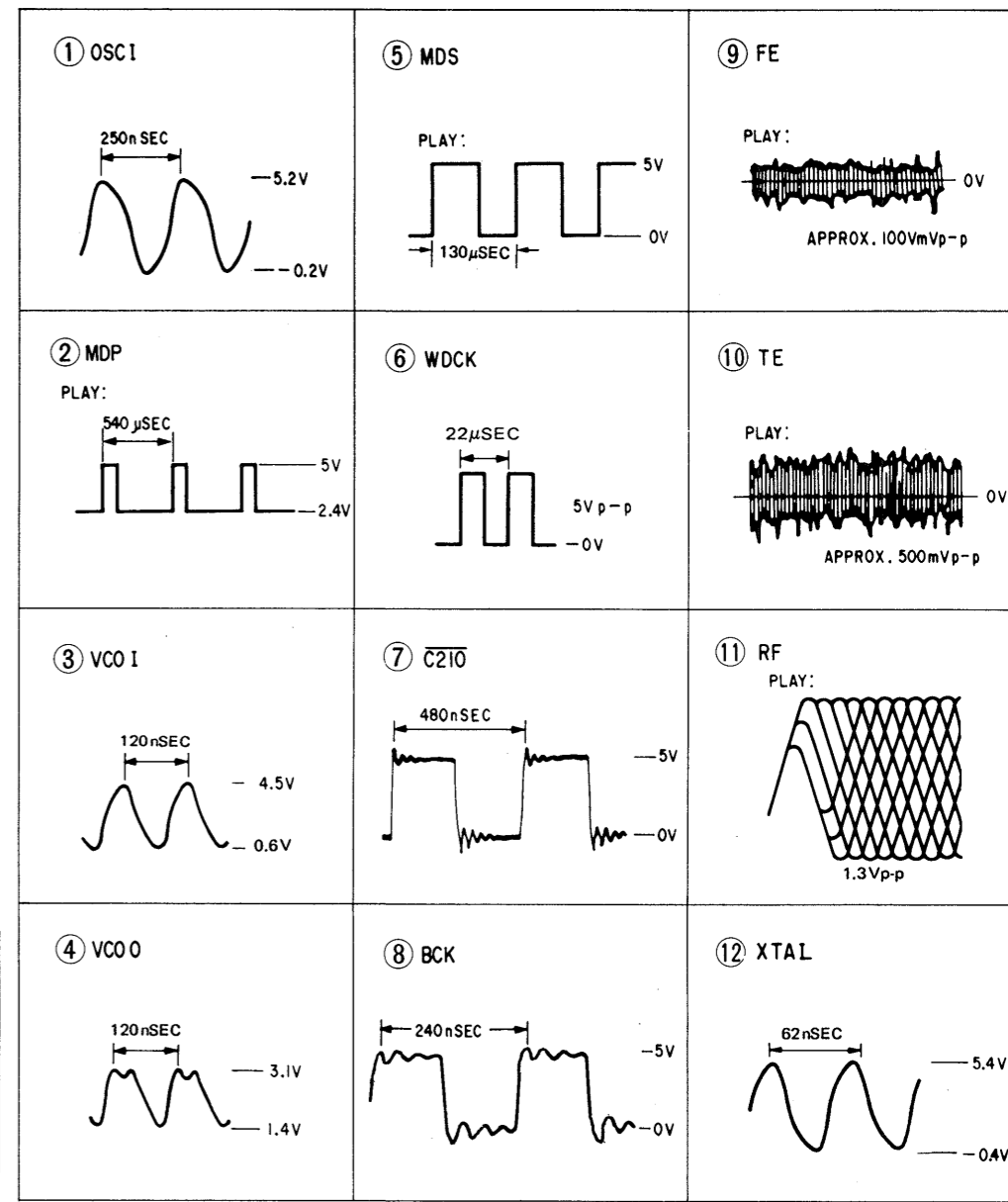

Note on Schematic Diagram:

- All capacitors are in μF unless otherwise noted. pF: μpF 50WV or less are not indicated except for electrolytics and tantalums.
- All resistors are in Ω and $\frac{1}{4}\text{W}$ or less unless otherwise specified.
- Δ : internal component.
- --- : B + line
- --- : B - line
- --- : adjustment for repair
- Signal path.
- --- : CD
- Voltage and waveforms are dc with respect to ground under no-signal conditions. no mark: STOP Mode (): PLAY

- Voltages are taken with a VOM. (Input impedance $10\text{M}\Omega$) Voltage variations may be noted due to normal production tolerances.
- Waveforms are taken with an oscilloscope. Voltage variations may be noted due to normal production tolerances.
- Circled numbers refer to waveforms.

Note:
The components identified by mark Δ or dotted line with mark Δ are critical for safety. Replace only with part number specified.



Note:
Les composants identifiés par une marque Δ sont critiques pour la sécurité. Ne les remplacer que par une pièce portant le numéro spécifié.

SECTION 4 EXPLODED VIEWS

NOTE:

- The mechanical parts with no reference number in the exploded views are not supplied.
- The construction parts of an assembled part are indicated with a collation number in the remark column.
- Items marked "★" are not stocked since they are seldom required for routine service. Some delay should be anticipated when ordering these items.

- Due to standardization, parts with part number suffix -XX and -X may be different from the parts specified in the components used on the set.
- Color Indication of Appearance Parts
Example:
(RED) ... KNOB, BALANCE (WHITE)
↑ Cabinet's Color ↑ Parts' Color

The components identified by mark  or dotted line with mark  are critical for safety. Replace only with part number specified.

Les composants identifiés par une marque  sont critiques pour la sécurité. Ne les remplacer que par une pièce portant le numéro spécifié.

4-1. GENERAL

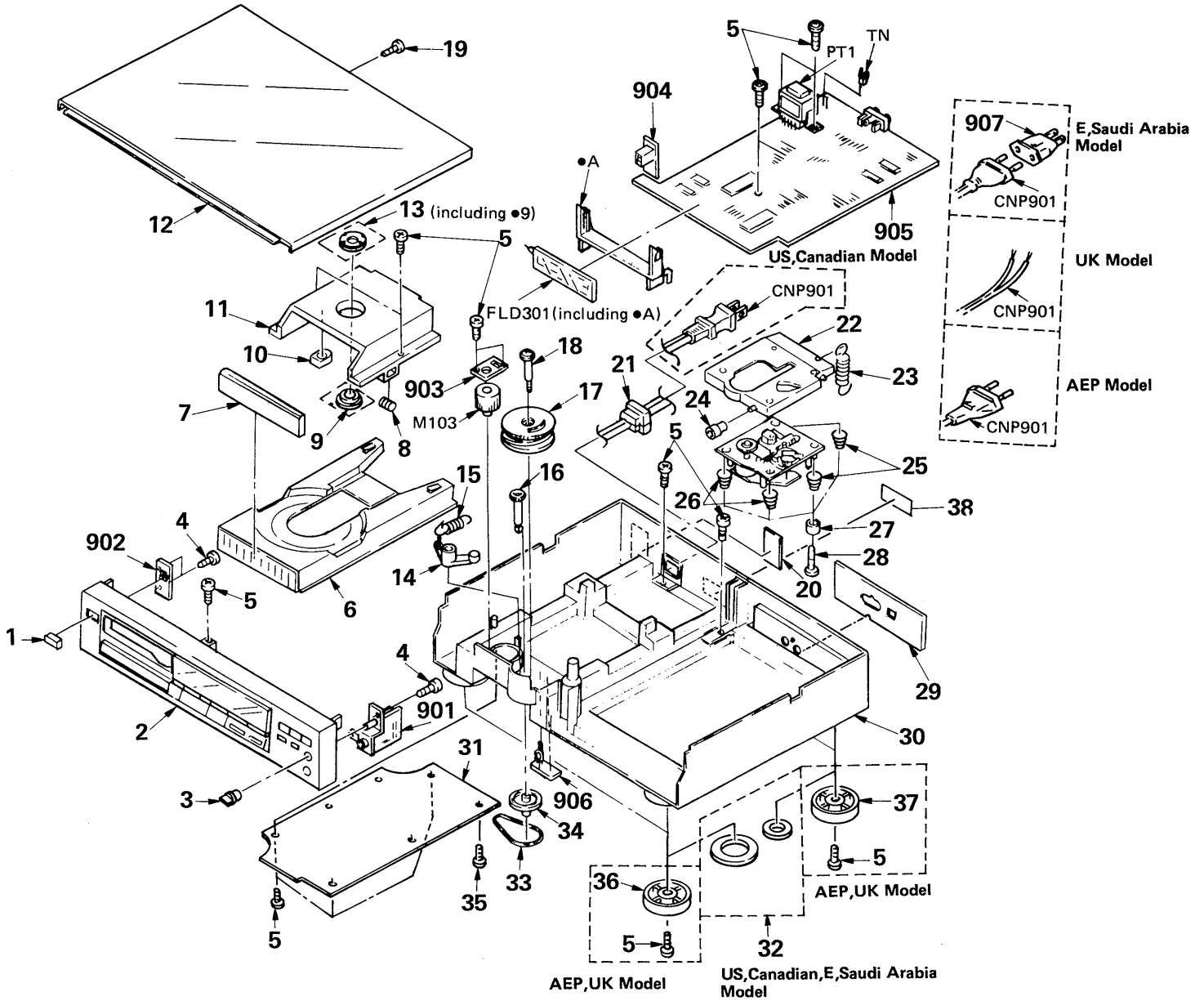

No.	Part No.	Description	Remarks
1	4-922-921-01	BUTTON (POWER)	
2	X-4922-555-1	(270:US,Canadian)...PANEL ASSY, FRONT	
	X-4922-556-1	(270:AEP).....PANEL ASSY, FRONT	
	X-4922-557-1	(270:Saudi Arabia)...PANEL ASSY, FRONT	
	X-4922-564-1	(470:E).....PANEL ASSY, FRONT	
	X-4922-565-1	(470:AEP,UK).....PANEL ASSY, FRONT	
	X-4922-566-1	(470:US,Canadian)...PANEL ASSY, FRONT	
3	4-923-522-12	KNOB (B.TYPE), LOV	
4	7-685-134-19	SCREW +BTP 2.6X8 TYPE2 N-S	
5	7-685-647-79	SCREW +BVTP 3X10 TYPE2 N-S	
6	*4-925-307-01	TABLE, DISK	
7	4-925-343-21	(270:Saudi Arabia/470)...PANEL, LOADING	
	4-925-343-31	(270:US,Canadian,AEP)...PANEL, LOADING	
8	4-925-335-01	SPRING, COMPRESSION	
9	*4-918-679-04	PULLEY, PRESS	
10	*4-922-529-01	DAMPER	
11	*4-925-345-01	HOLDER (MG)	
12	4-925-348-01	CASE	
13	A-4665-024-A	MAGNET ASSY	
14	4-917-519-01	LEVER, SET	
15	4-917-514-01	SPRING, TENSION	
16	4-922-508-01	GEAR (DRIVING)	
17	4-925-306-01	GEAR (LOADING)	
18	7-685-152-19	SCREW, STEP	
19	7-685-650-79	SCREW (2), TAPPING	
20	*3-704-217-01	(US,Canadian)...LABEL	
21	*3-703-244-00	(EXCEPT E)...BUSHING (2104), CORD	
	*3-703-571-11	(E).....BUSHING (S)(4516), CORD	
22	*4-922-514-01	BRACKET (BU-5)	
23	4-917-526-01	SPRING, TENSION	
24	4-917-515-01	ROLLER	
25	4-917-507-01	SPRING (H)	
26	4-917-541-01	SPRING (B)	
27	4-917-508-01	HOLDER, SP	
28	7-685-535-11	SCREW +BTP 2.6X10 TYPE2 N-S	



No.	Part No.	Description	Remarks
29	*4-927-301-51	(470:US) ...PLATE (O/P TERMINAL), INDICATION	
	*4-927-301-61	(470:Canadian) ...PLATE (O/P TERMINAL), INDICATION	
	*4-927-301-71	(470:AEP) ...PLATE (O/P TERMINAL), INDICATION	
	*4-927-301-81	(470:E) ...PLATE (O/P TERMINAL), INDICATION	
	*4-929-054-01	(470:UK) ...PLATE (O/P TERMINAL), INDICATION	
	*4-927-302-51	(270:US).....PLATE, INDICATION	
	*4-927-302-61	(270:Canadian).....PLATE, INDICATION	
	*4-927-302-71	(270:AEP).....PLATE, INDICATION	
	*4-927-302-81	(270:Saudi Arabia)...PLATE, INDICATION	
30	*4-925-346-01	CHASSIS	
31	*4-929-049-01	PLATE (H), BOTTOM	
32	4-922-942-01	(US,Canadian,E,Saudi Arabia)..FOOT (FELT)	
33	4-917-522-02	BELT	
34	4-922-512-01	PULLEY	
35	7-685-879-01	SCREW +BVTT 3X30 (S)	
36	X-4922-917-1	(AEP,UK)...FOOT ASSY (F)	
37	X-4922-918-1	(AEP,UK)...FOOT ASSY (R)	
38	*4-885-838-00	(AEP,UK,E,Saudi Arabia)...LABEL, CLASS 1	
901	*1-628-122-11	PC BOARD, H.P	
902	*1-628-123-11	PC BOARD, SW	
903	*1-628-124-11	PC BOARD, LD MOTOR	
904	*1-628-120-11	PC BOARD, SENSOR	
905	*A-4651-236-A	(E,Saudi Arabia).....MOUNTED PCB, MAIN	
	*A-4651-237-A	(US,Canadian,AEP,UK)...MOUNTED PCB, MAIN	
906	*1-628-125-11	PC BOARD, IO SWITCH	
907	△1-526-565-00	(E)...AC PLUG, ADAPTOR	
	△1-506-401-11	(Saudi Arabia)...ADAPTOR, CONVERSION	
	△CNP901.1-551-188-XX	(E).....CORD, POWER	
	△CNP901.1-555-795-00	(AEP,Saudi Arabia)...CORD, EULO PLUG	
	△CNP901.1-556-035-00	(UK).....CORD, POWER	
	△CNP901.1-557-577-11	(US,Canadian)...CORD, POWER	
	FLD301 1-519-479-21	INDICATOR TUBE, FLUORESCENT	
	M103 A-4608-346-A	MOTOR ASSY, LOADING	
	PT1 △1-449-024-11	(US,Canadian,UK)...TRANSFORMER, POWER	
	PT1 △1-449-025-11	(AEP).....TRANSFORMER, POWER	
	PT1 △1-449-026-11	(E,Saudi Arabia)...TRANSFORMER, POWER	
	TN *1-535-688-11	TERMINAL	

Note:
The components identified by mark △ or dotted line with mark △ are critical for safety. Replace only with part number specified.

Note:
Les composants identifiés par une marque △ sont critiques pour la sécurité. Ne les remplacer que par une pièce portant le numéro spécifié.

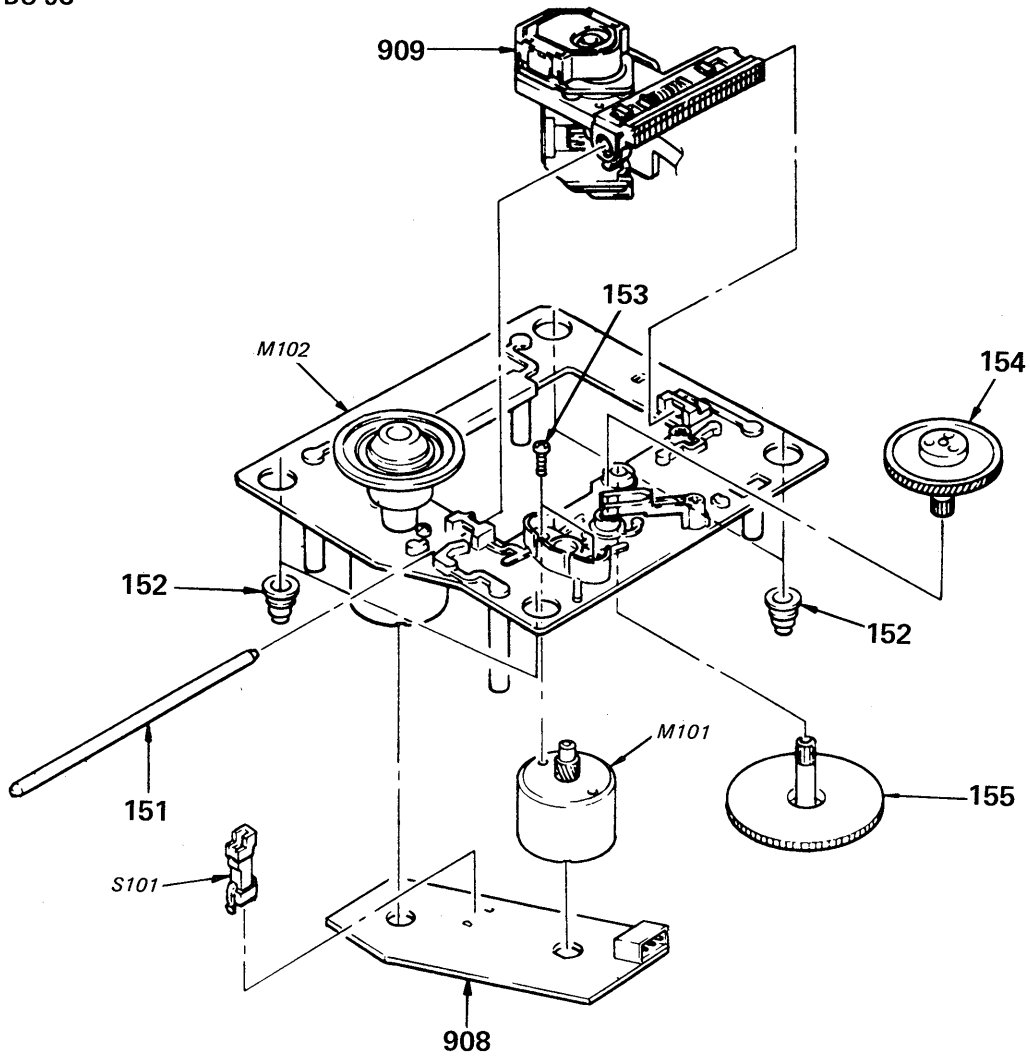
4-2. BU-5C



<p>Note: The components identified by mark  or dotted line with mark  are critical for safety. Replace only with part number specified.</p>	<p>Note: Les composants identifiés par une marque  sont critiques pour la sécurité. Ne les remplacer que par une pièce portant le numéro spécifié.</p>
---	--

No.	Part No.	Description	Remarks
151	4-917-565-01	SHAFT, SLED	
152	4-917-562-01	INSULATOR	
153	7-621-255-15	SCREW +P 2X3	
154	4-917-567-01	GEAR (M)	
155	4-917-564-01	GEAR (P), FLATNESS	

No.	Part No.	Description	Remarks
908	*1-626-304-11	PC BOARD, SL/SP MOTOR	
909	 8-848-062-01	DEVICE, OPTICAL KSS-150A(H)	
M101	X-4917-504-1	MOTOR ASSY (SLED)	
M102	X-4917-523-1	MOTOR ASSY (SPINDLE)	
S101	1-571-274-11	SWITCH, LEAF	

SECTION 5

ELECTRICAL PARTS LIST

NOTE:

- Due to standardization, replacements in the parts list may be different from the parts specified in the diagrams or the components used on the set.
- Items marked "★" are not stocked since they are seldom required for routine service. Some delay should be anticipated when ordering these items.
- If there are two or more same circuits in a set such as a stereophonic machine, only typical circuit parts may be indicated and capacitors and resistors in other same circuits may be omitted.

CAPACITORS:MF: μ F, PF: μ MF.**RESISTORS**

- All resistors are in ohms.
- F: nonflammable

COILS

- MMH: mH, UH: μ H

SEMICONDUCTORSIn each case, U: μ , for example:UA...: μ A..., UPA...: μ PA...,UPC...: μ PC, UPD...: μ PD...



The components identified by mark Δ or dotted line with mark Δ are critical for safety. Replace only with part number specified.

Les composants identifiés par une marque Δ sont critiques pour la sécurité. Ne les remplacer que par une pièce portant le numéro spécifié.

Ref.No.	Part No.	Description	Ref.No.	Part No.	Description
901	*1-628-122-11	PC BOARD, H.P	C227	1-124-443-00	ELECT 100MF 20% 10V
902	*1-628-123-11	PC BOARD, SW	C228	1-162-282-31	CERAMIC 100PF 10% 50V
903	*1-628-124-11	PC BOARD, LD MOTOR	C231	1-124-443-00	ELECT 100MF 20% 10V
904	*1-628-120-11	PC BOARD, SENSOR			
905	*A-4651-236-A	(E,Saudi Arabia)...MOUNTED PCB, MAIN	C232	1-164-159-11	CERAMIC 0.1MF 50V
	*A-4651-237-A	(US,Canadian,AEP,UK) ...MOUNTED PCB, MAIN	C233	1-164-159-11	CERAMIC 0.1MF 50V
			C234	1-123-875-11	ELECT 10MF 20% 50V
906	*1-628-125-11	PC BOARD, IO SWITCH	C235	1-124-477-11	ELECT 47MF 20% 16V
907	Δ 1-526-565-00	(E)...AC PLUG, ADAPTOR	C236	1-124-477-11	ELECT 47MF 20% 16V
908	*1-626-304-11	PC BOARD, SL/SP MOTOR	C238	1-136-165-00	FILM 0.1MF 5% 50V
909	Δ 8-848-062-01	DEVICE, OPTICAL KSS-150A(H)			
C101	1-124-556-11	ELECT 2200MF 20% 16V	C239	1-161-375-00	CERAMIC 0.0022MF 30% 16V
C102	1-124-898-11	ELECT 4700MF 20% 16V	C240	1-162-291-31	CERAMIC 560PF 10% 50V
C103	1-124-572-11	ELECT 100MF 20% 63V	C301	1-123-875-11	ELECT 10MF 20% 50V
C104	1-123-875-11	ELECT 10MF 20% 50V	C302	1-124-443-00	ELECT 100MF 20% 10V
C105	1-124-443-00	ELECT 100MF 20% 10V	C303	1-124-499-11	ELECT 1MF 20% 50V
C106	1-124-443-00	ELECT 100MF 20% 10V	C304	1-124-499-11	ELECT 1MF 20% 50V
C107	1-124-927-11	ELECT 4.7MF 20% 50V	C305	1-124-902-00	ELECT 0.47MF 20% 50V
C108	1-123-875-11	ELECT 10MF 20% 50V	C306	1-136-159-00	FILM 0.033MF 5% 50V
C109	1-161-379-00	CERAMIC 0.01MF 20% 16V	C307	1-164-159-11	CERAMIC 0.1MF 50V
C110	1-124-443-00	ELECT 100MF 20% 10V	C308	1-164-159-11	CERAMIC 0.1MF 50V
C112	1-124-499-11	ELECT 1MF 20% 50V	C309	1-161-379-00	CERAMIC 0.01MF 20% 16V
C201	1-161-375-00	CERAMIC 0.0022MF 30% 16V	C310	1-164-159-11	CERAMIC 0.1MF 50V
C202	1-136-153-00	FILM 0.01MF 5% 50V	C311	1-162-291-31	CERAMIC 560PF 10% 50V
C203	1-136-153-00	FILM 0.01MF 5% 50V	C312	1-162-291-31	CERAMIC 560PF 10% 50V
C204	1-162-205-31	CERAMIC 18PF 5% 50V	C313	1-162-291-31	CERAMIC 560PF 10% 50V
C205	1-162-205-31	CERAMIC 18PF 5% 50V	C401	1-164-159-11	CERAMIC 0.1MF 50V
C206	1-124-902-00	ELECT 0.47MF 20% 50V	C402	1-162-203-31	CERAMIC 15PF 5% 50V
C208	1-124-443-00	ELECT 100MF 20% 10V	C403	1-162-203-31	CERAMIC 15PF 5% 50V
C209	1-124-443-00	ELECT 100MF 20% 10V	C404	1-164-159-11	CERAMIC 0.1MF 50V
C210	1-161-377-00	CERAMIC 0.0047MF 20% 16V	C405	1-124-443-00	ELECT 100MF 20% 10V
C211	1-136-159-00	FILM 0.033MF 5% 50V	C406	1-124-927-11	ELECT 4.7MF 20% 50V
C212	1-124-477-11	ELECT 47MF 20% 16V	C407	1-124-927-11	ELECT 4.7MF 20% 50V
C213	1-164-159-11	CERAMIC 0.1MF 50V	C408	1-124-443-00	ELECT 100MF 20% 10V
C214	1-162-294-31	CERAMIC 0.001MF 10% 50V	C409	1-124-443-00	ELECT 100MF 20% 10V
C215	1-161-375-00	CERAMIC 0.0022MF 30% 16V	C410	1-162-291-31	CERAMIC 560PF 10% 50V
C216	1-136-165-00	FILM 0.1MF 5% 50V	C411	1-162-291-31	CERAMIC 560PF 10% 50V
C217	1-136-159-00	FILM 0.033MF 5% 50V	C412	1-164-159-11	CERAMIC 0.1MF 50V
C218	1-123-382-00	ELECT 3.3MF 20% 50V	C413	1-162-286-31	CERAMIC 220PF 10% 50V
C219	1-136-165-00	FILM 0.1MF 5% 50V	C414	1-162-286-31	CERAMIC 220PF 10% 50V
C220	1-161-379-00	CERAMIC 0.01MF 20% 16V	C601	1-161-374-11	CERAMIC 0.0015MF 30% 16V
C221	1-161-377-00	CERAMIC 0.0047MF 20% 16V	C602	1-161-374-11	CERAMIC 0.0015MF 30% 16V
C222	1-124-927-11	ELECT 4.7MF 20% 50V	CN101	*1-564-338-00	PIN, CONNECTOR 4P
C223	1-124-477-11	ELECT 47MF 20% 16V	CN200	*1-564-495-11	PIN, CONNECTOR 2P
C224	1-162-294-31	CERAMIC 0.001MF 10% 50V	CN200A	*1-564-720-11	PIN, CONNECTOR (SMALL TYPE) 4P
C225	1-124-499-11	ELECT 1MF 20% 50V	CN202	*1-564-710-11	PIN, CONNECTOR (SMALL TYPE) 8P
C226	1-124-499-11	ELECT 1MF 20% 50V	CN203	*1-564-706-11	PIN, CONNECTOR (SMALL TYPE) 4P
			CN204	*1-564-339-00	PIN, CONNECTOR 5P

Ref.No.	Part No.	Description
CN301	*1-566-165-11	CONNECTOR, BOARD TO BOARD 3P
CN401	*1-564-337-00	PIN, CONNECTOR 3P
△CNP901.1	1-551-188-XX	(E).....CORD, POWER
△CNP901.1	1-555-795-00	(AEP,Saudi Arabia)...CORD, EULO PLUG
△CNP901.1	1-556-035-00	(UK).....CORD, POWER
△CNP901.1	1-557-577-11	(US,Canadian)...CORD, POWER
D1	8-719-109-97	DIODE RD6.8ES-B2
D3	8-719-107-94	DIODE 1SS202-1
D4	8-719-107-94	DIODE 1SS202-1
D5	8-719-107-94	DIODE 1SS202-1
D6	8-719-200-02	DIODE 10E2
D7	8-719-200-02	DIODE 10E2
D8	8-719-200-02	DIODE 10E2
D9	8-719-200-02	DIODE 10E2
D10	8-719-200-02	DIODE 10E2
FLD301	1-519-479-21	INDICATOR TUBE, FLUORESCENT
IC1	8-759-631-40	IC M52 94P
IC2	8-752-034-00	IC CXA1081S
IC3	8-752-032-30	IC CXA1082BS
IC4	8-759-035-28	IC CXA1291P
IC5	8-759-035-28	IC CXA1291P
IC6	8-759-978-34	IC MSC6458-32SS
IC7	8-752-328-62	IC CXD1125Q
IC8	8-752-323-64	IC CXK5816M-12L
IC9	8-752-328-72	IC CXD2550P
IC10	8-759-805-36	IC CXD1161P-3
IC11	8-759-631-39	IC M5204P
IC12	8-759-605-43	IC M523 1TL
IC13	8-749-920-03	IC GP1U52
IB101	1-233-171-11	COMPOSITION CIRCUIT BLOCK
IB102	1-233-171-11	COMPOSITION CIRCUIT BLOCK
J401	*1-562-999-21	JACK, PIN 2P (LINE OUT)
J601	1-566-936-61	JACK, LARGE TYPE (PHONES)
M101	X-4917-504-1	MOTOR ASSY (SLED)
M102	X-4917-523-1	MOTOR ASSY (SPINDLE)
M103	A-4608-346-A	MOTOR ASSY, LOADING
PT1	△.1-449-024-11	(US,Canadian,UK)...TRANSFORMER, POWER
PT1	△.1-449-025-11	(AEP).....TRANSFORMER, POWER
PT1	△.1-449-026-11	(E,Saudi Arabia)...TRANSFORMER, POWER
Q1	8-729-600-94	TRANSISTOR 2SK381-C
Q2	8-729-116-57	TRANSISTOR 2SB1068-K
Q3	8-729-900-80	TRANSISTOR DTC114ES
Q4	8-729-115-77	TRANSISTOR BA1L4M
Q5	8-729-115-77	TRANSISTOR BA1L4M
Q6	8-729-115-77	TRANSISTOR BA1L4M

Ref.No.	Part No.	Description				
R101	1-249-439-11	CARBON	68K	5%	1/4W	
R102	1-249-423-11	CARBON	3.3K	5%	1/4W	
R103	1-249-417-11	CARBON	1K	5%	1/4W	
R201	1-247-864-11	CARBON	24K	5%	1/4W	
R202	1-249-433-11	CARBON	22K	5%	1/4W	
R203	1-249-417-11	CARBON	1K	5%	1/4W	
R204	1-249-397-11	CARBON	22	5%	1/4W	
R205	1-247-806-11	CARBON	91	5%	1/4W	
R206	1-249-432-11	CARBON	18K	5%	1/4W	
R207	1-249-432-11	CARBON	18K	5%	1/4W	
R208	1-249-425-11	CARBON	4.7K	5%	1/4W	
R209	1-249-441-11	CARBON	100K	5%	1/4W	
R210	1-249-417-11	CARBON	1K	5%	1/4W	
R211	1-249-425-11	CARBON	4.7K	5%	1/4W	
R212	1-247-882-11	CARBON	130K	5%	1/4W	
R213	1-249-440-11	CARBON	82K	5%	1/4W	
R214	1-249-423-11	CARBON	3.3K	5%	1/4W	
R215	1-247-896-11	CARBON	510K	5%	1/4W	
R216	1-249-429-11	CARBON	10K	5%	1/4W	
R218	1-249-433-11	CARBON	22K	5%	1/4W	
R219	1-249-414-11	CARBON	560	5%	1/4W	
R220	1-249-441-11	CARBON	100K	5%	1/4W	
R221	1-215-434-00	METAL	3.6K	1%	1/6W	
R222	1-249-429-11	CARBON	10K	5%	1/4W	
R223	1-249-441-11	CARBON	100K	5%	1/4W	
R224	1-249-393-11	CARBON	10	5%	1/4W	
R225	1-249-435-11	CARBON	33K	5%	1/4W	
R226	1-247-889-00	CARBON	270K	5%	1/4W	
R227	1-249-393-11	CARBON	10	5%	1/4W	
R228	1-249-423-11	CARBON	3.3K	5%	1/4W	
R229	1-247-881-00	CARBON	120K	5%	1/4W	
R230	1-249-427-11	CARBON	6.8K	5%	1/4W	
R231	1-249-425-11	CARBON	4.7K	5%	1/4W	
R232	1-249-437-11	CARBON	47K	5%	1/4W	
R233	1-249-435-11	CARBON	33K	5%	1/4W	
R234	1-247-882-11	CARBON	130K	5%	1/4W	
R235	1-247-883-00	CARBON	150K	5%	1/4W	
R236	1-247-883-00	CARBON	150K	5%	1/4W	
R237	1-247-882-11	CARBON	130K	5%	1/4W	
R238	1-249-432-11	CARBON	18K	5%	1/4W	
R239	1-249-432-11	CARBON	18K	5%	1/4W	
R240	1-249-423-11	CARBON	3.3K	5%	1/4W	
R301	1-249-425-11	CARBON	4.7K	5%	1/4W	
R302	1-249-425-11	CARBON	4.7K	5%	1/4W	
R303	1-249-425-11	CARBON	4.7K	5%	1/4W	

Note:
The components identified by mark  or dotted line with mark  are critical for safety. Replace only with part number specified.

Note:
Les composants identifiés par une marque  sont critiques pour la sécurité. Ne les remplacer que par une pièce portant le numéro spécifié.

Ref.No.	Part No.	Description			
R304	1-249-435-11	CARBON	33K	5%	1/4W
R305	1-249-435-11	CARBON	33K	5%	1/4W
R306	1-249-435-11	CARBON	33K	5%	1/4W
R307	1-249-417-11	CARBON	1K	5%	1/4W
R308	1-249-417-11	CARBON	1K	5%	1/4W
R309	1-249-417-11	CARBON	1K	5%	1/4W
R310	1-215-469-00	METAL	100K	1%	1/6W
R311	1-215-469-00	METAL	100K	1%	1/6W
R312	1-249-429-11	CARBON	10K	5%	1/4W
R313	1-249-441-11	CARBON	100K	5%	1/4W
R314	1-249-433-11	CARBON	22K	5%	1/4W
R315	1-247-903-00	CARBON	1M	5%	1/4W
R316	1-249-417-11	CARBON	1K	5%	1/4W
R317	1-249-417-11	CARBON	1K	5%	1/4W
R318	1-249-417-11	CARBON	1K	5%	1/4W
R319	1-249-429-11	CARBON	10K	5%	1/4W
R320	1-249-429-11	CARBON	10K	5%	1/4W
R401	1-249-411-11	CARBON	330	5%	1/4W
R402	1-249-411-11	CARBON	330	5%	1/4W
R403	1-249-417-11	CARBON	1K	5%	1/4W
R404	1-249-411-11	CARBON	330	5%	1/4W
R405	1-249-417-11	CARBON	1K	5%	1/4W
R406	1-249-419-11	CARBON	1.5K	5%	1/4W
R407	1-249-435-11	CARBON	33K	5%	1/4W
R408	1-249-435-11	CARBON	33K	5%	1/4W
R409	1-249-439-11	CARBON	68K	5%	1/4W
R410	1-249-439-11	CARBON	68K	5%	1/4W
R411	1-249-439-11	CARBON	68K	5%	1/4W
R412	1-249-439-11	CARBON	68K	5%	1/4W
R413	1-249-417-11	CARBON	1K	5%	1/4W
R414	1-249-417-11	CARBON	1K	5%	1/4W
R601	1-249-402-11	CARBON	56	5%	1/4W
R602	1-249-402-11	CARBON	56	5%	1/4W
RV201	1-228-995-00	RES, ADJ, CARBON 22K			
RV202	1-228-993-00	RES, ADJ, CARBON 4.7K			
RV203	1-228-995-00	RES, ADJ, CARBON 22K			
RV204	1-228-995-00	RES, ADJ, CARBON 22K			
RV205	1-228-990-00	RES, ADJ, METAL GLAZE 1K			
RV601	1-238-302-11	RES, VAR, CARBON 1K/1K (PHONE LEVEL)			

Ref.No.	Part No.	Description
S1	1-571-685-11	SWITCH, KEY BOARD (TIME)
S2	1-571-686-11	SWITCH, KEY BOARD (◀◀)
S3	1-571-686-11	SWITCH, KEY BOARD (▶▶)
S4	1-571-685-11	SWITCH, KEY BOARD (AUTO SPACE)
S5	1-571-686-11	SWITCH, KEY BOARD (▶▶)
S6	1-571-685-11	SWITCH, KEY BOARD (◀◀)
S7	1-571-685-11	SWITCH, KEY BOARD (REPEAT)
S8	1-571-686-11	SWITCH, KEY BOARD (OPEN/CLOSE)
S9	1-571-685-11	SWITCH, KEY BOARD (▶▶)
S10	1-571-685-11	SWITCH, KEY BOARD (PROGRAM)
S11	1-571-685-11	SWITCH, KEY BOARD (EDIT/TIME FADE)
S12	1-571-685-11	SWITCH, KEY BOARD (SHUFFLE)
S13	1-571-685-11	SWITCH, KEY BOARD (CHECK)
S14	1-571-685-11	SWITCH, KEY BOARD (CONTINUE)
S15	1-571-686-11	SWITCH, KEY BOARD (■)
S16	1-571-685-11	SWITCH, KEY BOARD (CLEAR)
S101	1-571-274-11	SWITCH, LEAF
S501	1-571-305-11	SWITCH, PUSH (1 KEY)(POWER)
S701	1-571-300-11	SWITCH, ROTARY (I/O)
TN	*1-535-688-11	TERMINAL
VS1	△.1-571-722-11	(E,Saudi Arabia) ...SWITCH, VOLTAGE SELECTOR
X301	1-577-082-11	VIBRATOR, CERAMIC (4MHz)
X401	1-567-908-21	VIBRATOR, CRYSTAL (16.9MHz)

ACCESSORY & PACKING MATERIAL

1-465-050-11	(470)...REMOTE COMMANDER (RM-D170)
△.1-506-401-11	(Saudi Arabia)...ADAPTOR, CONVERSION
△.1-526-565-00	(E)...AC PLUG, ADAPTOR
1-558-543-11	CORD, CONNECTION (○)
1-559-533-11	CORD, CONNECTION (○)
*3-704-217-01	LABEL
3-704-217-31	LABEL, CERTIFICATION
*3-704-339-01	SHEET (STANDARD), PROTECTION
3-750-022-11	(AEP,UK,E,Saudi Arabia) ...MANUAL, INSTRUCTION
3-750-022-21	(US,Canadian)...MANUAL, INSTRUCTION
3-750-022-31	(Canadian)...MANUAL, INSTRUCTION
3-750-022-41	(AEP)...MANUAL, INSTRUCTION
*3-795-629-11	(AEP)...INSTRUCTION
*4-925-389-01	CUSHION
*4-929-061-11	(470)...INDIVIDUAL CARTON
*4-929-061-31	(270)...INDIVIDUAL CARTON

Note:
The components identified by mark Δ or dotted line with mark Δ are critical for safety. Replace only with part number specified.

Note:
Les composants identifiés par une marque Δ sont critiques pour la sécurité. Ne les remplacer que par une pièce portant le numéro spécifié.

CDP-270/470

SONY[®] SERVICE MANUAL

*US Model
Canadian Model
AEP Model
E Model
CDP-270*

SUPPLEMENT-1

File this supplement with the service manual.

This SUPPLEMENT-1 is for the model made in France.
Refer to the CDP-270/470 SERVICE MANUAL for related
information not contained in this SUPPLEMENT-1.

*US Model
Canadian Model
AEP Model
UK Model
E Model
CDP-470*

[MODEL IDENTIFICATION]

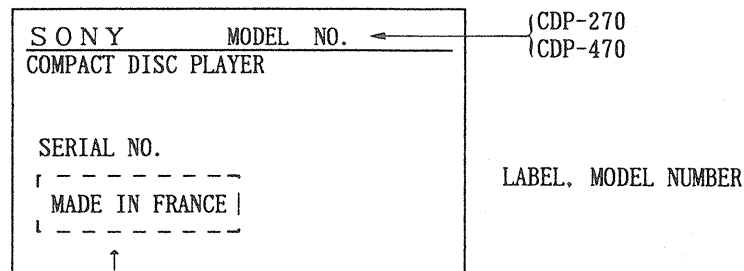

Identify the set with the indication of "MADE IN FRANCE" here.

The following parts are not used in the CDP-270/470 (US, Canadian, UK, E MODEL), but used in the CDP-270/470 made in FRANCE only.

ELECTRICAL PARTS LIST

Page	Ref No.	Part No.	Description
21	901	*1-630-126-11	PC BOARD, HP
21	902	*1-630-127-11	PC BOARD, SW
21	903	*1-624-793-11	PC BOARD, LOADING MOTOR
21	905	*A-4617-039-A	MOUNTED PCB, MAIN
21	908	*1-629-464-11	PC BOARD, SL/SP MOTOR
21	909	△.8-848-062-01	DEVICE, OPTICAL KSS-150A (H)

MAIN BOARD

Page	Ref No.	Part No.	Description
21	C202, 203	1-130-483-00	MYLAR 0.01MF 5% 50V
21	C211, 217	1-130-489-00	MYLAR 0.033MF 5% 50V
21	C238	1-136-162-00	FILM 0.056MF 5% 50V
21	C306,	1-130-489-00	MYLAR 0.033MF 5% 50V
21	C402	1-162-202-31	CERAMIC 13PF 5% 50V
22	CN101	*1-564-706-11	PIN, CONNECTOR (SMALL TYPE) 4P
22	CN204	*1-564-707-11	PIN, CONNECTOR (SMALL TYPE) 5P
22	CN401	*1-564-705-11	PIN, CONNECTOR (SMALL TYPE) 3P
22	CNP901	△.1-574-127-11	CORD, POWER
22	IC4, 5	8-759-805-18	IC LA6520
22	IC6	8-759-988-85	IC MSC6458-38SS

The components identified by mark △ or dotted line with mark △ are critical for safety. Replace only with part number specified.

Les composants identifiés par une marque △ sont critiques pour la sécurité. Ne les remplacer que par une pièce portant le numéro spécifié.

- Items marked "*" are not stocked since they are seldom required for routine service. Some delay should be anticipated when ordering these items.

● PRINTED WIRING BOARDS

- The following PC BOARDS are used in the model made in France only.

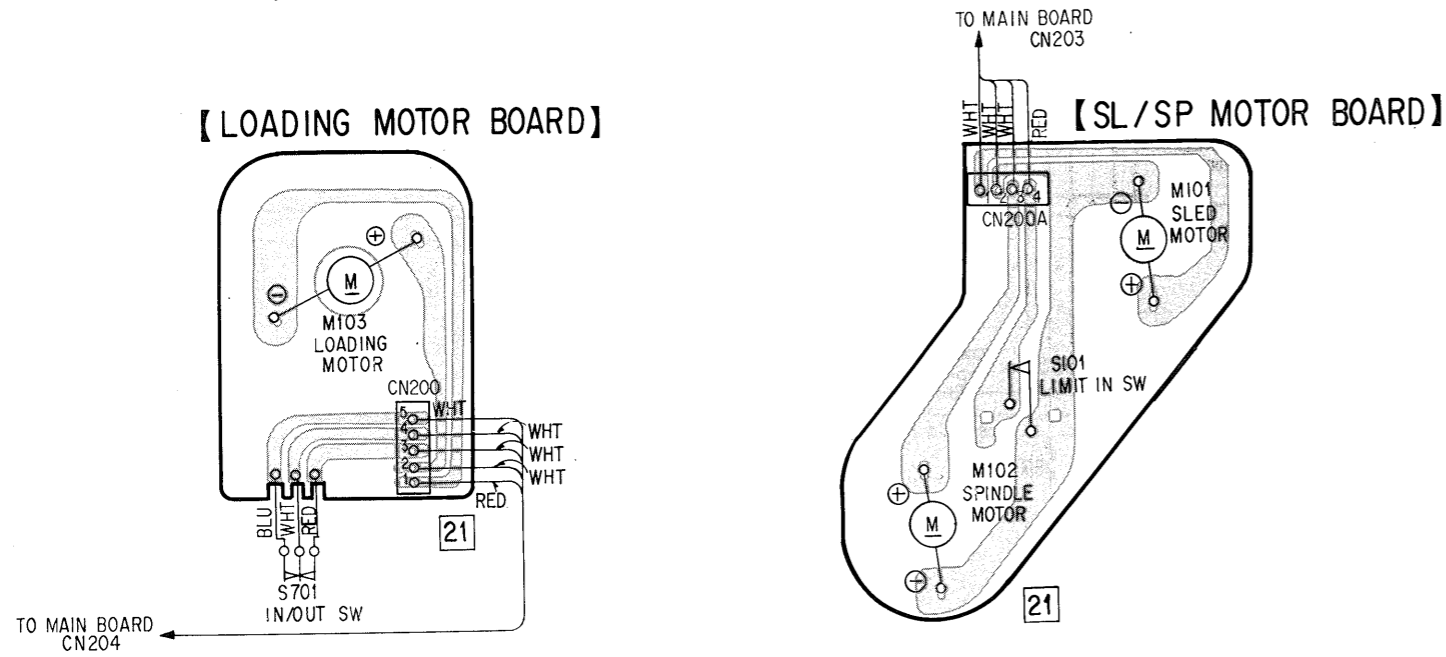

22	IC8	8-752-323-64	IC LC9600P-144
22	IC10	8-759-821-24	IC LC7881-C
22	R229	1-249-440-00	CARBON 82K 5% 1/4W
22	R234, 237	1-249-883-00	CARBON 150K 5% 1/4W
23	S1	1-554-088-00	SWITCH, KEY BOARD
23	S2.3	1-571-810-11	SWITCH, KEY BOARD
23	S4	1-554-088-00	SWITCH, KEY BOARD
23	S5	1-571-810-11	SWITCH, KEY BOARD
23	S6.7	1-554-088-00	SWITCH, KEY BOARD
23	S8	1-571-810-11	SWITCH, KEY BOARD
23	S9-14	1-554-088-00	SWITCH, KEY BOARD
23	S15	1-571-810-11	SWITCH, KEY BOARD
23	S16	1-554-088-00	SWITCH, KEY BOARD
23	X301	1-567-686-11	VIBRATOR, CERAMIC
23	X401	1-577-328-11	VIBRATOR, CRYSTAL

I/O SWITCH BOARD (Not MADE IN FRANCE)

Page	Ref No.	Part No.	Description
12.21	906		PC BOARD, I/O SWITCH
12.21	S701		SWITCH, ROTARY (IN/OUT)
12.21	CONNECTOR		CONNECTOR 2P, 5P

LD MOTOR BOARD (Not MADE IN FRANCE)

Page	Ref No.	Part No.	Description
12.21	903		PC BOARD, LD MOTOR
12.21	CN200		PIN, CONNECTOR 2P
12.21	M103		LOADING MOTOR

LOADING MOTOR BOARD

Page	Ref No.	Part No.	Description
12.21	CN200	*1-564-721-11	PIN, CONNECTOR (SMALL TYPE) 5P
12.21	M103	X-2641-336-1	LOADING MOTOR
12.21	S701	1-571-312-11	SWITCH, LEAF (IN/OUT)

SL/SP MOTOR BOARD

Page	Ref No.	Part No.	Description
12.23	S101	1-570-822-22	LIMIT IN SWITCH
12.22	M101	X-2641-344-1	SLED MOTOR
12.22	M102	X-2641-350-1	SPINDLE MOTOR
12.22	CN200A	*1-564-720-11	PIN, CONNECTR (SMALL TYPE) 4P

ACCESSORY & PACKING MATERIAL

Page	Part No.	Description
23	3-750-022-51	MANUAL, INSTRUCTION
23	3-750-022-61	MANUAL, INSTRUCTION
23	*4-929-507-21	(CDP-470) ... INDIVIDUAL CARTON
23	*4-929-507-31	(CDP-270) ... INDIVIDUAL CARTON
23	*4-929-058-01	(CDP-270) ... LABEL, MODEL NUMBER
23	*4-929-059-01	(CDP-470) ... LABEL, MODEL NUMBER

NOTE:

- The mechanical parts with no reference number in the exploded views are not supplied.
- The construction parts of an assembled part are indicated with a collation number in the remark column.
- Items marked "*" are not stocked since they are seldom required for routine service. Some delay should be anticipated when ordering these items.
- Due to standardization, parts with part number suffix -XX and -X may be different from the parts specified in the components used on the set.
- Color Indication of Appearance Parts Example: (RED) ... KNOB, BALANCE (WHITE)

The components identified by mark Δ or dotted line with mark Δ are critical for safety. Replace only with part number specified.

Les composants identifiés par une marque Δ sont critiques pour la sécurité. Ne les remplacer que par une pièce portant le numéro spécifié.

1. CABINET SECTION (MADE IN FRANCE TYPE)

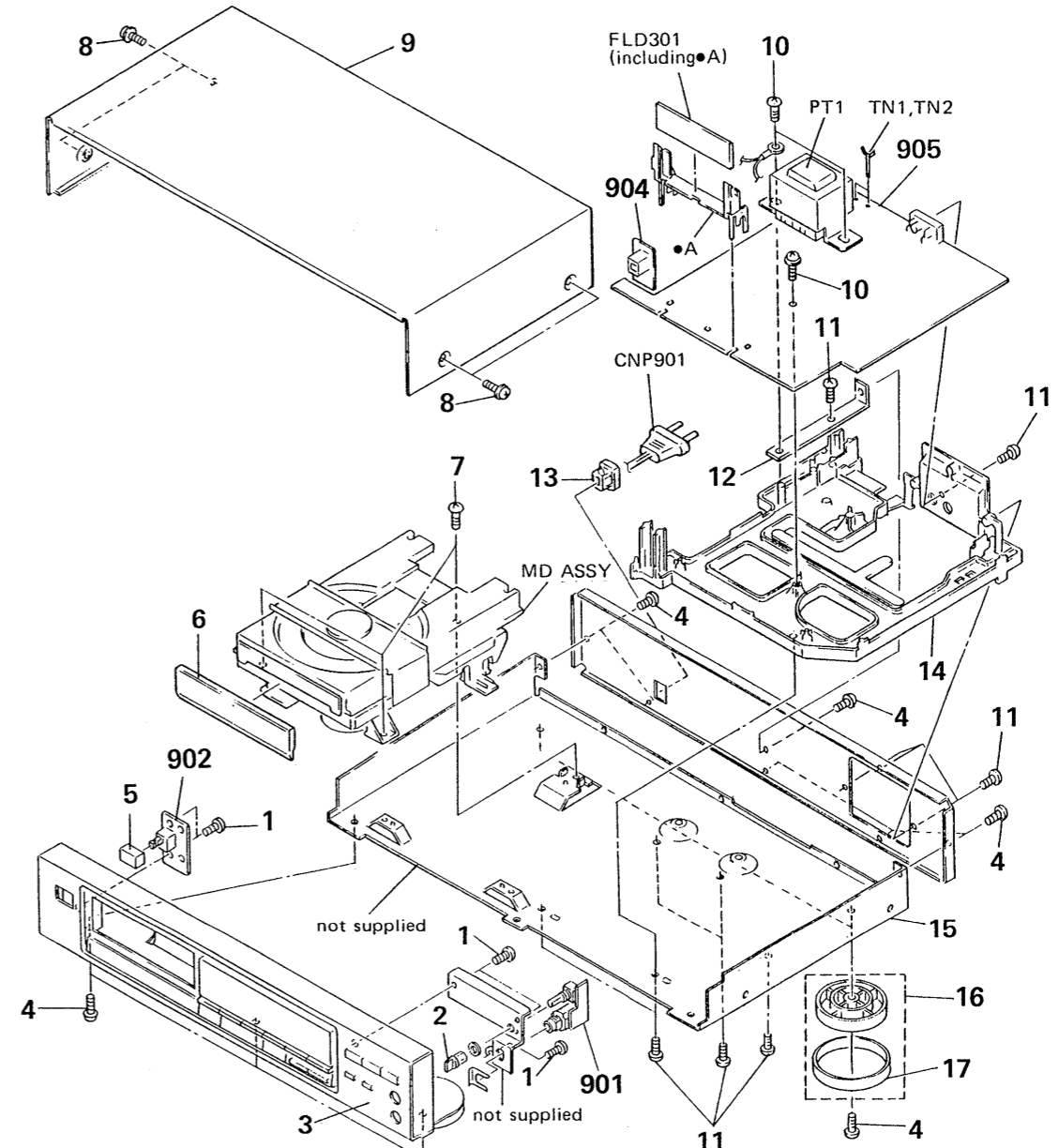

No.	Part No.	Description	Remarks	No.	Part No.	Description	Remarks
1	7-685-134-19	SCREW +BTP 2.6X8 TYPE2 N-S		13	*3-703-244-00	BUSHING (2104), CORD	
2	4-923-522-12	KNOB (B.TYPE), VOL (PHONE LEVEL)		14	*4-929-034-01	HOLDER (MAIN PC BOARD)	
3	X-4922-561-3	(CDP-270)...PANEL ASSY, FRONT		15	*4-929-024-01	PANEL, BACK	
	X-4922-562-3	(CDP-470)...PANEL ASSY, FRONT		16	4-929-030-11	RING (DIA.58A), ORNAMENTAL	
4	7-685-872-09	SCREW +BVT 3X8 (S)		17	X-4885-935-1	FOOT ASSY	
5	4-922-921-01	BUTTON (POWER)		901	*1-630-126-11	PC BOARD, HP	
6	4-929-026-11	(CDP-270)...PANEL, LOADING		902	*1-630-127-11	PC BOARD, SW	
	4-929-026-21	(CDP-470)...PANEL, LOADING		905	*A-4167-039-A	MOUNTED PCB, MAIN	
7	7-682-548-04	SCREW, S TIGHT, (+) PTTWH (3X8)		Δ .CNP901	1-574-127-11	CORD, POWER	
8	3-704-366-31	SCREW (CASE) (M3X6)		FLD301	1-519-479-21	INDICATOR TUBE, FLUORESCENT	
9	4-929-035-11	CASE		PT1	Δ .1-449-025-11	TRANSFORMER, POWER	
10	7-685-647-79	SCREW, TAPPING		TN1	*1-535-688-11	TERMINAL	
11	7-685-647-79	SCREW +BVT 3X10 TYPE2 N-S		TN2	*1-535-688-11	TERMINAL	
12	*4-929-029-01	BRACKET (TRANSFORMER)					

2. BU-5C (1) (MADE IN FRANCE TYPE)

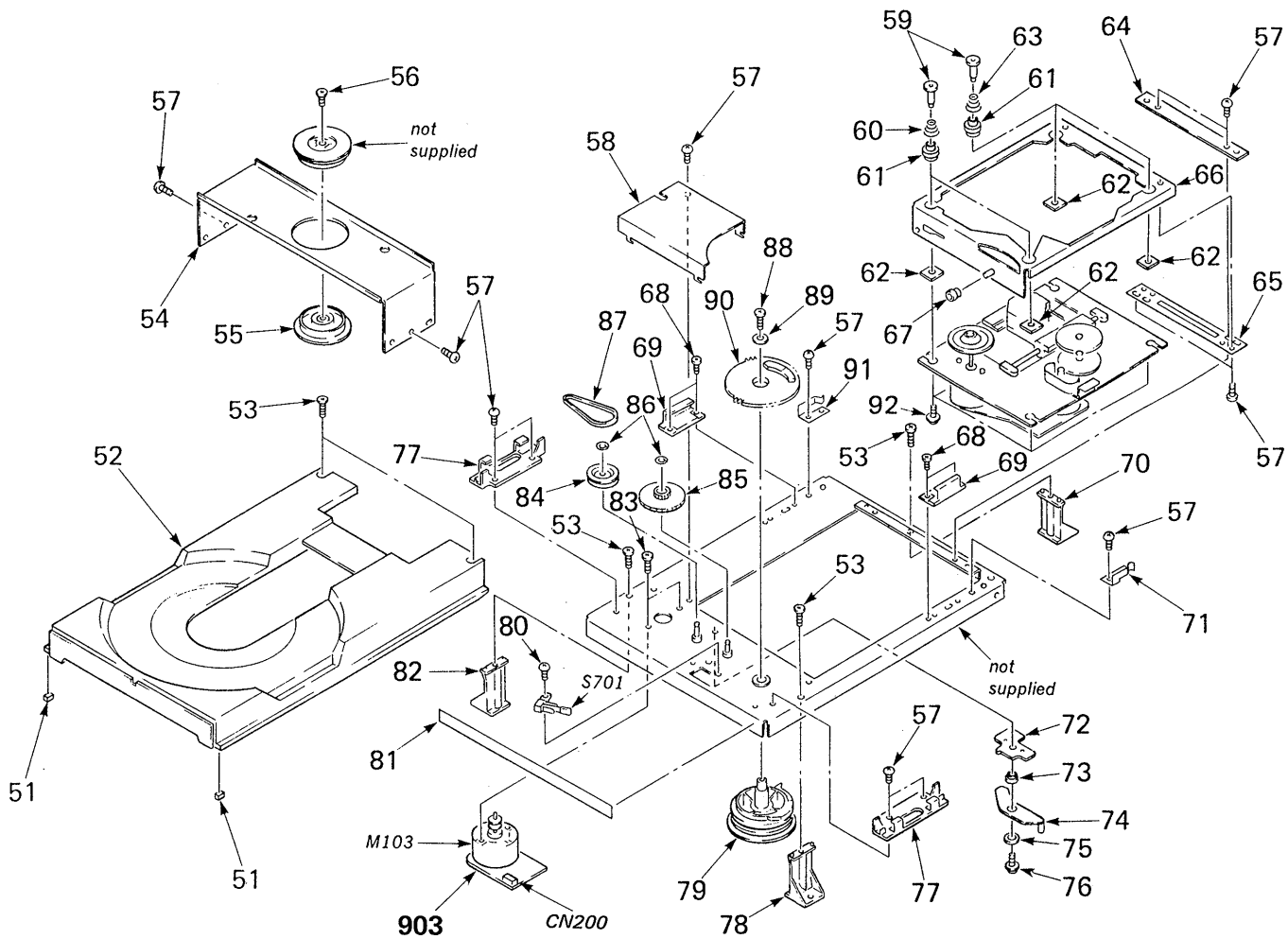

Ref.No	Part No.	Description	Remarks
51	*2-642-125-01	DAMPER	
52	2-642-156-01	TRAY (SP)	
53	7-685-647-79	SCREW +BTP 3X10 TYPE2 N-S	
54	*2-642-165-01	CHASSIS (SP), CHUCK	
55	2-642-432-01	PULLEY, CHUCKING	
56	7-685-132-19	SCREW +BTP 2.6X5 TYPE2 N-S	
57	7-621-770-67	SCREW +BVTT 2.6X6 (S)	
58	*2-642-149-02	COVER (SP), GEAR	
59	2-642-160-01	SHAFT (T) (SP)	
60	2-642-139-01	SPRING (A)	
61	2-642-158-01	INSULATOR (C)	
62	2-642-159-01	PLATE (T) (SP)	
63	2-642-137-01	SPRING (B)	
64	*2-642-170-01	RETAINER (SP), HINGE	
65	*2-642-164-01	HINGE (SP)	
66	*X-2642-105-2	CHASSIS ASSY (SP), SUB	
67	2-642-169-01	ROLLER (SP)	
68	7-621-255-25	SCREW +PTT 2X4 (S)	
69	2-642-162-01	HOLDER (REAR) (SP), TRAY	
70	*2-642-512-01	BOSS (REAR), MD FITTING	
71	*2-642-146-01	GUIDE (RIGHT) (SP), TRAY	
72	2-642-173-01	PLATE (SP), LINK	
73	*2-642-133-02	BOSS	

Ref.No	Part No.	Description	Remarks
74	*X-2642-109-1	LINK ASSY (AU), STOPPER	
75	*2-642-172-01	SPACER (SP)	
76	7-685-134-19	SCREW (+ PTPWH) (2.6X8)	
77	2-642-161-01	HOLDER (FRONT) (SP), TRAY	
78	*2-642-510-01	BOSS (RIGHT), MD FITTING	
79	2-642-153-01	CAM (SP), CONTROL	
80	7-621-255-25	SCREW +BVTT 2X4 (S)	
81	*2-642-157-03	TAPE, FRONT	
82	*2-642-511-01	BOSS (LEFT), MD FITTING	
83	7-621-775-00	SCREW +B 2.6X3	
84	4-913-731-01	PULLEY, ROADING	
85	2-642-148-01	GEAR (SP), MIDWAY	
86	3-558-708-21	WASHER, STOPPER	
87	3-653-387-00	BELT, LM	
88	7-685-135-19	SCREW +BTP 2.6X10 TYPE2 N-S	
89	4-812-554-00	WASHER	
90	2-642-154-03	GEAR (SP), DRIVE	
91	*2-642-147-01	GUIDE (LEFT) (SP), TRAY	
92	2-642-142-01	SCREW	
903	1-624-793-21	PC BOARD, LOADING MOTOR	
CN200	1-564-721-11	PIN CONNECTOR (SMALL TYPE) 5P	
M103	X-2641-336-1	MOTOR ASSY (LOADING)	
S701	1-571-312-11	SWITCH, LEAF (IN/OUT SW)	

3. BU-5C (2) (MADE IN FRANCE TYPE)

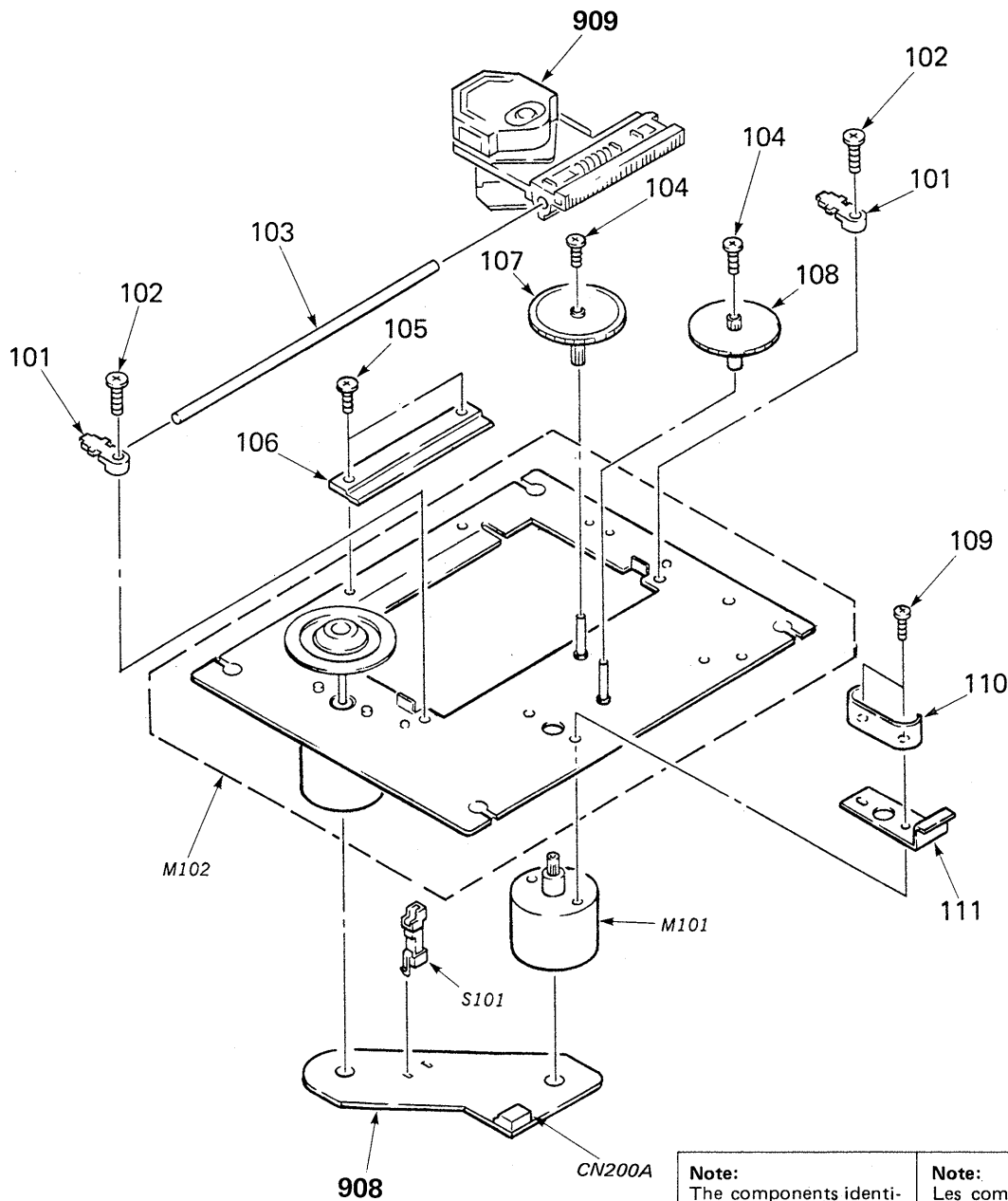

<p>Note: The components identified by mark or dotted line with mark are critical for safety. Replace only with part number specified.</p>	<p>Note: Les composants identifiés par une marque sont critiques pour la sécurité. Ne les remplacer que par une pièce portant le numéro spécifié.</p>
--	---

Ref.No	Part No.	Description	Remarks	Ref.No	Part No.	Description	Remarks
101	2-641-448-02	CLAMP, SHAFT		110	2-641-434-01	COVER, GEAR	
102	2-641-447-01	SCREW (2.6X8), +STP		111	*2-641-371-01	STOPPER	
103	*4-910-431-01	SHAFT, SLIDE		908	*1-629-464-11	PC BOARD, SL/SP MOTOR	
104	3-303-809-31	SCREW (M1.7X3.0), SPECIAL HEAD		909	8-848-062-01	DEVICE, OPTICAL KSS-150A (H)	
105	2-641-386-01	SCREW (2X5), TAPPING (S)		CN200A	*1-564-720-11	PIN, CONNECTOR (SMALL TYPE) 4P	
106	2-641-439-11	HOLDER, SLIDE		M101	X-2641-344-1	SLED MOTOR	
107	2-641-404-02	GEAR (A)		M102	X-2641-350-1	SPINDLE MOTOR	
108	2-641-403-06	GEAR (B)		S101	1-570-822-22	SWITCH, LEAF (LIMIT IN)	
109	7-621-255-35	SCREW, +P 2X5					

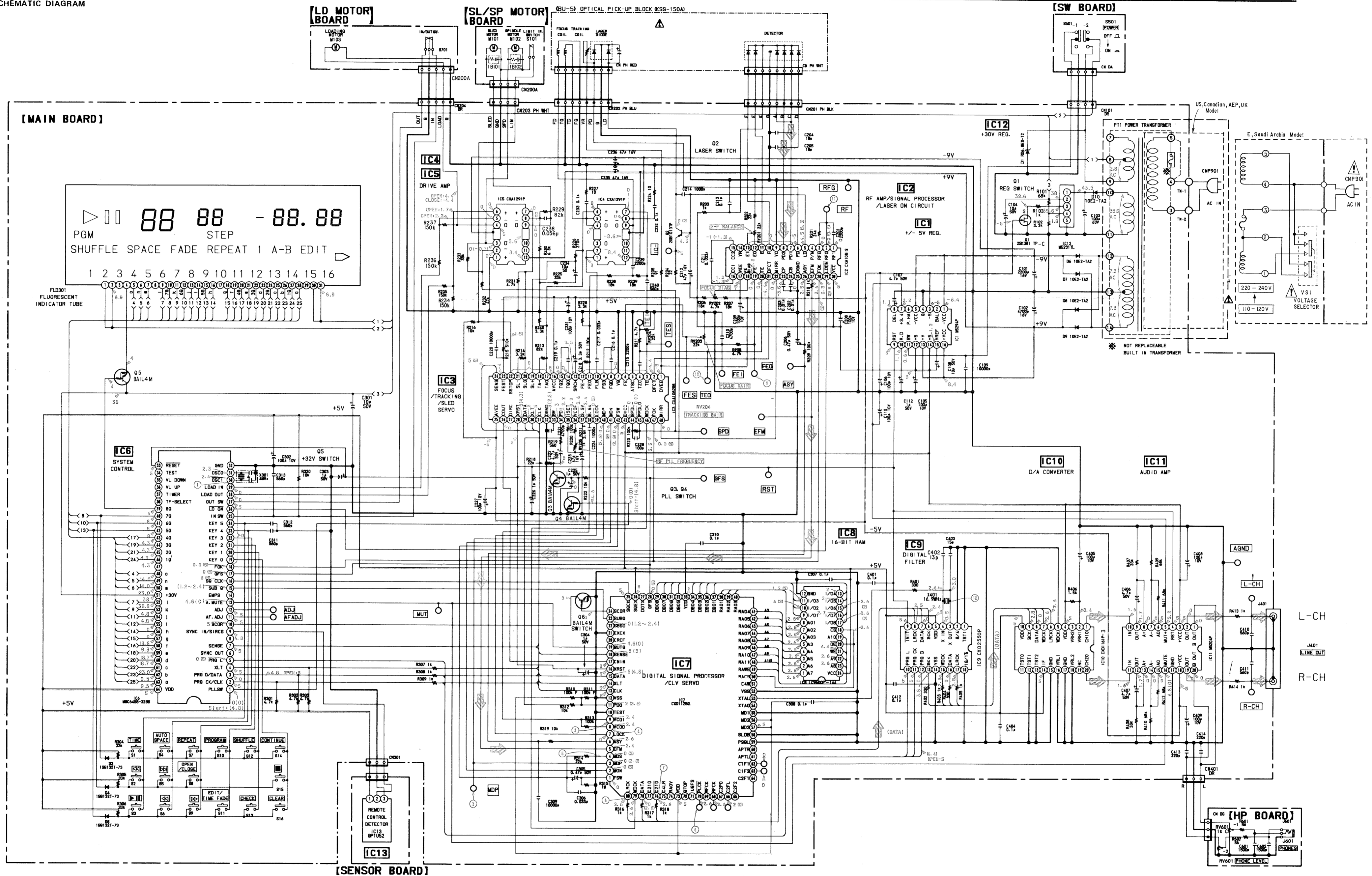

Note on Schematic Diagram:

- All capacitors are in μF unless otherwise noted. pF : μF 50WV or less are not indicated except for electrolytics and tantalums.
- All resistors are in Ω and $\frac{1}{2}\text{W}$ or less unless otherwise specified.
- Δ : internal component.

— : B + line
 - - - : B - line
 □ : adjustments for repair
 ○ : Signal path.
 ⊕ : CD
 ⊖ : Voltage and waveforms are dc with respect to ground under no-signal conditions.
 no mark: STOP Mode
 (): PLAY

- Voltages are taken with a VOM. (Input impedance 10M Ω) Voltage variations may be noted due to normal production tolerances.
- Waveforms are taken with an oscilloscope. Voltage variations may be noted due to normal production tolerances.
- Circled numbers refer to waveforms.

Note:
 The components identified by mark Δ or dotted line with mark Δ are critical for safety. Replace only with part number specified.

Note:
 Les composants identifiés par une marque Δ sont critiques pour la sécurité. Ne les remplacer que par une pièce portant le numéro spécifié.

