

CDP-897

SERVICE MANUAL

*Canadian Model
AEP Model
E Model
Australian Model*



Model Name Using Similar Mechanism	CDP-797
CD Mechanism Type	CDM14-5BD8A
Optical Pick-Up Block Type	BU-5BD8A

SPECIFICATIONS

Compact disc player

Frequency response	2 Hz – 20 kHz ± 0.5 dB
Signal to noise ratio	More than 112 dB
Dynamic range	More than 98 dB
Harmonic distortion	Less than 0.0027%
Channel separation	More than 107 dB

Outputs

LINE OUT (FIXED) (phono jacks)	Output level 2V (at 50 kilohms, non DSP mode.) Load impedance over 10 kilohms
LINE OUT (VARIABLE) (phono jacks)	Output level max. 2V (at 50 kilohms, non DSP mode.) Load impedance over 50 kilohms
DIGITAL OUT (OPTICAL) (optical output connector)	Wave length 660 nm Output level – 18 dBm
HEADPHONES (Stereo phone jack) Laser output	Output level max. 28 mW Load impedance 32 ohms Max. 44.6 μ W This output is the value measured at a distance of about 200 mm from the objective lens surface on the Optical Pick-up Block.

General

Power requirements	AEP Model 220 – 230 V AC, 50/60 Hz Australian Model 240 V AC, 50 Hz Canadian Model 120 V AC, 60 Hz E Model 110 - 120 or 220 - 240 V AC adjustable, 50/60 Hz
--------------------	--

Power consumption	14 W
Dimensions (approx., including projections)	430×110×295 mm (w/h/d) (17×4 3/8×13 1/2 inches)
Weight (approx.)	3.9 kg (8 lbs 10 oz)

Remote commander

Remote control system	Infrared control
Power requirements	3 V DC with two batteries size AA (IEC designation R6)
Dimensions	62×18×175 mm (w/h/d) (2 1/2×23/32×7 inches)
Weight	130 g (4.6 oz) Including batteries

Supplied accessories

Connecting cord	1 (2 phono plugs ↔ 2 phono plugs)
Remote commander	1
Sony SUM-3(NS) batteries	2

Design and specifications are subject to change without notice.

COMPACT DISC PLAYER
SONY®

TABLE OF CONTENTS

<u>Section</u>	<u>Title</u>	<u>Page</u>
Specifications		1
Model Identification		2
Notes on Handling the Optical Pick-Up Block or Base Unit		2
1. GENERAL		
Identifying the Parts		3
2. DISASSEMBLY		4
3. ELECTRICAL CHECKS		5
4. DIAGRAMS		
4-1. Block Diagram		7
4-2. BD Section Printed Wiring Boards and Schematic Diagram		11
4-3. Main Section Printed Wiring Boards		15
4-4. Main Section Schematic Diagram		19
5. EXPLODED VIEWS		27
6. ELECTRICAL PARTS LIST		31

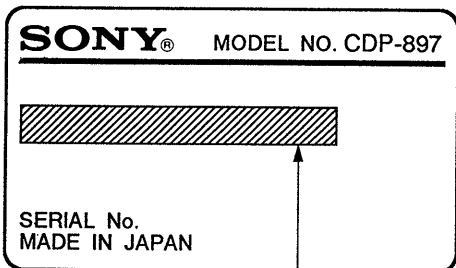

MODEL IDENTIFICATION

— Model Number Label —



- Canadian model: AC: 120 V 60 Hz 14W
- AEP, Germany model: AC: 220 – 230 V ~50/60 Hz
- Australian model: AC: 240 V ~50/60 Hz
- E model: AC: 110 – 120, 220 – 240 V ~50/60 Hz 14 W

SAFETY-RELATED COMPONENT WARNING!!

COMPONENTS IDENTIFIED BY MARK  OR DOTTED LINE WITH MARK  ON THE SCHEMATIC DIAGRAMS AND IN THE PARTS LIST ARE CRITICAL TO SAFE OPERATION. REPLACE THESE COMPONENTS WITH SONY PARTS WHOSE PART NUMBERS APPEAR AS SHOWN IN THIS MANUAL OR IN SUPPLEMENTS PUBLISHED BY SONY.

NOTES ON HANDLING THE OPTICAL PICK-UP BLOCK OR BASE UNIT

The laser diode in the optical pick-up block may suffer electrostatic breakdown because of the potential difference generated by the charged electrostatic load, etc. on clothing and the human body.

During repair, pay attention to electrostatic breakdown and also use the procedure in the printed matter which is included in the repair parts.

The flexible board is easily damaged and should be handled with care.

NOTES ON LASER DIODE EMISSION CHECK

The laser beam on this model is concentrated so as to be focused on the disc reflective surface by the objective lens in the optical pick-up block. Therefore, when checking the laser diode emission, observe more than 30 cm away from the objective lens.

For AEP, E, Australian Model

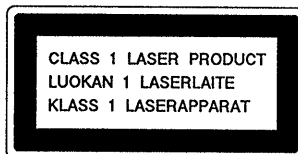

This Compact Disc player is classified as a CLASS 1 LASER product. The CLASS 1 LASER PRODUCT label is located on the rear exterior.

ATTENTION AU COMPOSANT AYANT RAPPORT À LA SÉCURITÉ!

LES COMPOSANTS IDENTIFIÉS PAR UNE MARQUE  SUR LES DIAGRAMMES SCHÉMATIQUES ET LA LISTE DES PIÈCES SONT CRITIQUES POUR LA SÉCURITÉ DE FONCTIONNEMENT. NE REMPLACER CES COMPOSANTS QUE PAR DES PIÈCES SONY DONT LES NUMÉROS SONT DONNÉS DANS CE MANUEL OU DANS LES SUPPLÉMENTS PUBLIÉS PAR SONY.

This section is extracted from instruction manual.

SECTION 1 GENERAL

Remote Commander

Refer to the pages indicated in () for details.

- 1 OPEN/CLOSE button (22)
- 2 DISPLAY MODE button (24)
- 3 MUSIC SCAN button (44)
- 4 Numeric buttons (28)
- 5 CLEAR button (42, 52)
- 6 CHECK button (62)
- 7 DSP SELECT button (32)
- 8 FLAT button (36)
- 9 FADER (fade in/fade out) button (78)
- 10 DSP1-20 button and indicator (32)
- 11 LINE OUT LEVEL (line out/headphones level) buttons (22)
- 12 SLOW (low speed manual search) buttons (28)
- 13 INDEX buttons (28)
- 14 AMS* buttons (28)
- 15 (stop) button (22)
- 16 (pause) button (22)
- 17 (play) button (22)
- 18 REPEAT (repeat/A-B repeat clear) button (48)
- 19 A → B repeat button (50)
- 20 A, SPACE (auto space)/A.CUE (auto cue) button (30, 78)
- 21 TIME button (24)
- 22 > 20 (over 20) button (26)
- 23 PLAY MODE buttons
- 24 CONTINUE button (22)
- 25 SHUFFLE button (38)
- 26 PROGRAM button (52)

* AMS is the abbreviation of Automatic Music Sensor.

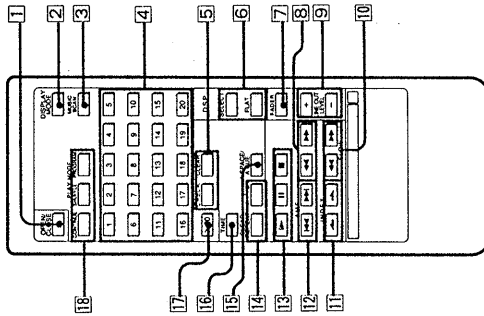

Identifying the Parts

Front Panel

Refer to the pages indicated in () for details.

- 1 POWER switch (22)
- 2 Disc tray (22)
- 3 OPEN/CLOSE button (22)
- 4 PLAY MODE buttons
- 5 CONTINUE button (22)
- 6 SHUFFLE button (38)
- 7 PROGRAM button (52)
- 8 PEAK SEARCH button (80)
- 9 A, SPACE/A, CUE button (30, 78)
- 10 DSP1-20 button and indicator (32)
- 11 MUSIC SCAN button (44)
- 12 Numeric buttons/DSP SELECT buttons (28, 32)
- 13 > 20 (over 20)/FLAT button (26, 36)
- 14 EFFECT level control (64)
- 15 LINE OUT/PHONE LEVEL control (22)
- 16 PHONES jack (22)
- 17 Display window (24)
- 18 Remote sensor
- 19 TIMER switch (82)
- 20 TIME button (24)
- 21 REPEAT button (48)
- 22 FADER (fade in/fade out) button (78)
- 23 EDIT/TIME FADE button (78)
- 24 CHECK (program check) button (52)
- 25 CLEAR (program clear) button (42, 52)
- 26 ← ← ← ← ← (manual search) buttons (28)
- 27 → → → → → (AMS* buttons) (28)
- 28 (stop) button (22)
- 29 (pause) button (22)
- 30 (play) button (22)

* AMS is the abbreviation of Automatic Music Sensor.

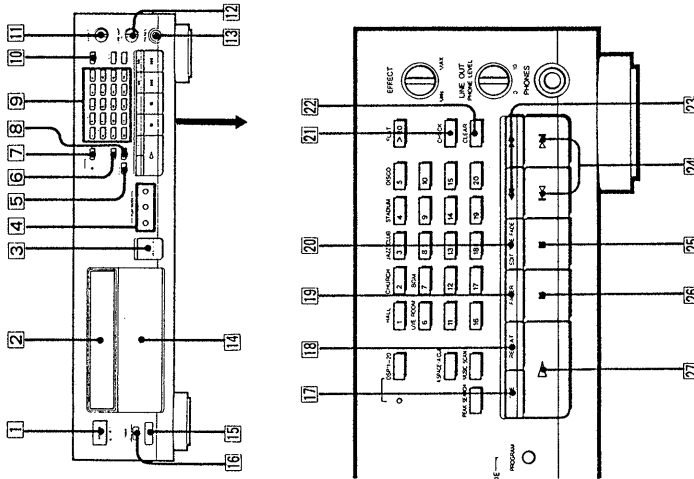

SECTION 2 DISASSEMBLY

- When removing the front panel assembly on electric power failure, first open the loading block by turning cam with a screwdriver as shown in the figure, next pull out the loading block with hand, and remove the loading panel as shown in the figure. Then remove the front panel assembly.

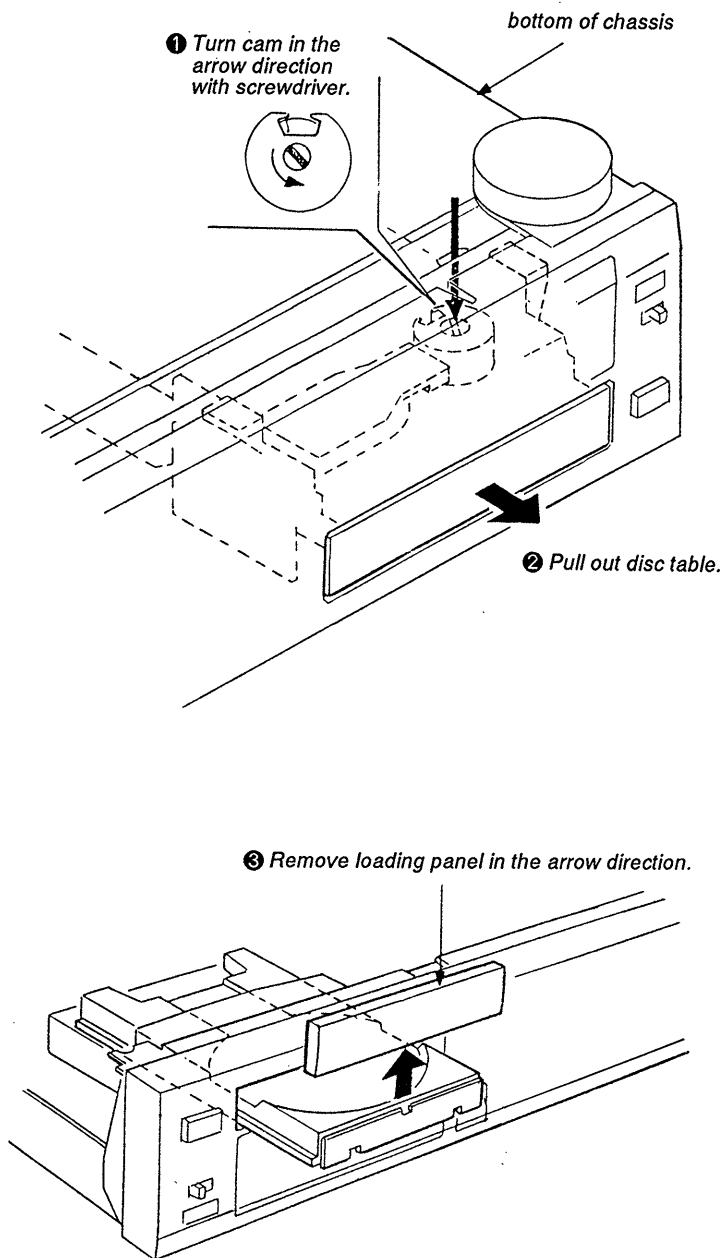

SECTION 3 ELECTRICAL CHECKS

1. Perform adjustments in the order given.
2. Use YEDS-18 disc (3-702-101-01) unless otherwise indicated.
3. Use the oscilloscope with more than 10 MΩ impedance.

RF LEVEL Check

Procedure:

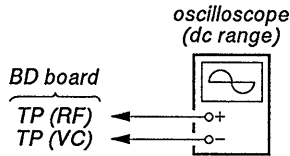

1. Connect oscilloscope to test point TP (RF) and TP (VC) on BD board.
2. Turn POWER switch on.
3. Put disc (YEDS-18) in and playback.
4. Confirm that RF level and eye pattern is optimum.
Optimum eye pattern means that shape "◇" can be clearly distinguished at the center of the waveform.

RF Signal Reference Waveform (eye pattern)

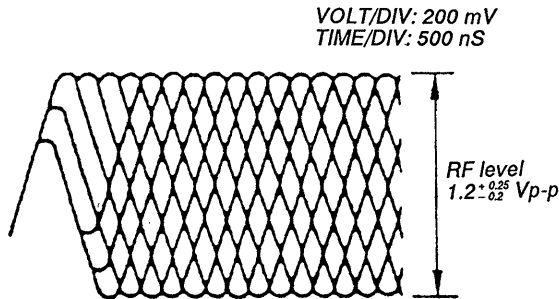

REFERENCE

E-F Balance Check

Procedure:

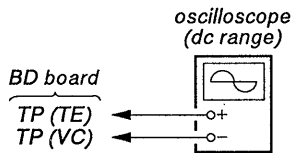

1. Connect test point TP (ADJ) to ground and TP (TEI) to VC with lead wires.
2. Connect oscilloscope to test point TP (TE).
3. Turn POWER switch on.
4. Put disc (YEDS-18) in and playback.
5. Confirm that the oscilloscope waveform is symmetrical on the top and bottom in relation to 0 V.
6. After check, remove the lead wires connected in step 1.

Note: Take sweep time as long as possible to obtain best waveform.

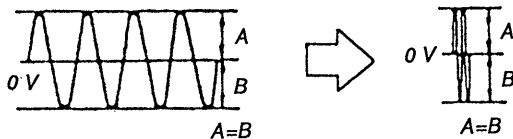

RF PLL Free-run Frequency Check

Procedure:

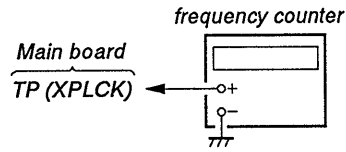

1. Turn POWER switch on.
2. Put disc (YEDS-18) in and playback.
3. Confirm that reading on frequency counter is 4.3218 MHz.

Focus/Tracking Gain Check

Focus/tracking gain determines the pick-up follow-up (vertical and horizontal) relative to mechanical noise and mechanical shock when the 2-axis device operate.

However, as these reciprocate, the microcomputer adjusts automatically at the point where both are satisfied.

- When gain is raised, the noise when the 2-axis device operates increases.
- When gain is lowered, mechanical shock and skipping occurs more easily.

When gain adjustment is off, the symptoms below appear.

Symptoms \ Gain	Focus	Tracking
<ul style="list-style-type: none"> • The time until music starts becomes longer for STOP → ► PLAY or automatic selection (◀◀ , ▶▶ buttons pressed). (Normally takes about 2 seconds.) 	low	low or high
<ul style="list-style-type: none"> • Music does not start and disc continues to rotate for STOP → ► PLAY or automatic selection (◀◀ , ▶▶ buttons pressed). 	—	low
<ul style="list-style-type: none"> • Sound is interrupted during PLAY. Or time counter display stops progressing. 	—	low
<ul style="list-style-type: none"> • Noise increases during 2-axis device operation. 	high	high

Focus Gain Check

1. Keep the set horizontal.
(If the set is not horizontal, this adjustment cannot be performed)
due to the gravity against the 2-axis device.)
2. Insert disc (YEDS-18: Fifth track) and press ▷ PLAY button.
3. Connect oscilloscope to Pin ⑦ of IC101 on BD board.
4. Confirm the waveform is as shown in the figure below.

Tracking Gain Check

1. Connect oscilloscope to Pin ④ of IC101 on BD board.
2. Confirm the waveform is as shown the figure below.

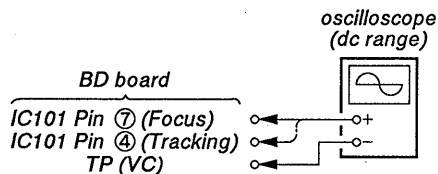

Normal

VOLT/DIV : 100 mV
TIME/DIV : 2 mS

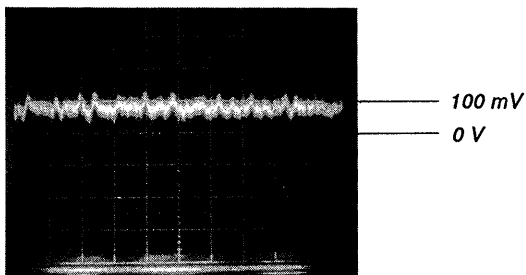

Normal

VOLT/DIV : 500 mV
TIME/DIV : 2 mS

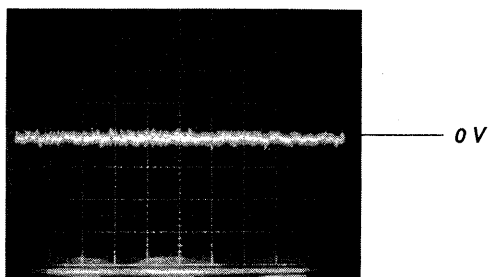

Focus gain is low.

VOLT/DIV : 100 mV
TIME/DIV : 2 mS

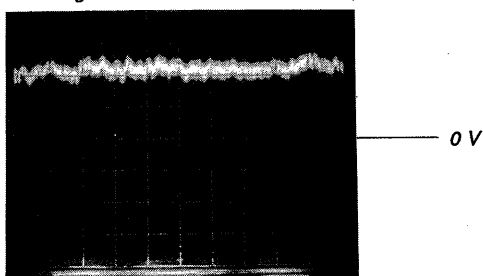

Tracking gain is low.

VOLT/DIV : 500 mV
TIME/DIV : 2 mS

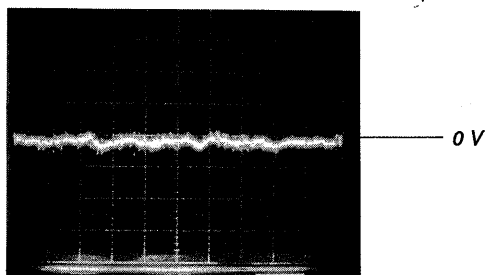

Focus gain is high.

VOLT/DIV : 100 mV
TIME/DIV : 2 mS

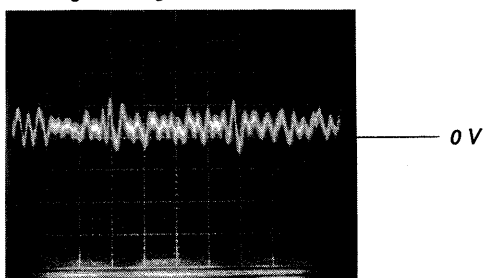

Tracking gain is high.

VOLT/DIV : 500 mV
TIME/DIV : 2 mS

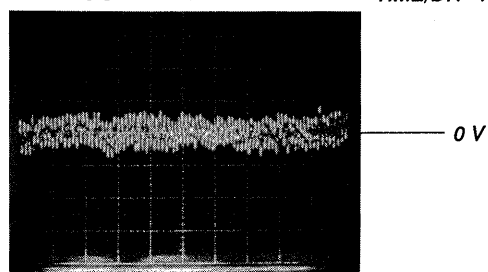

4-1. BLOCK DIAGRAM

SECTION 4
DIAGRAMS

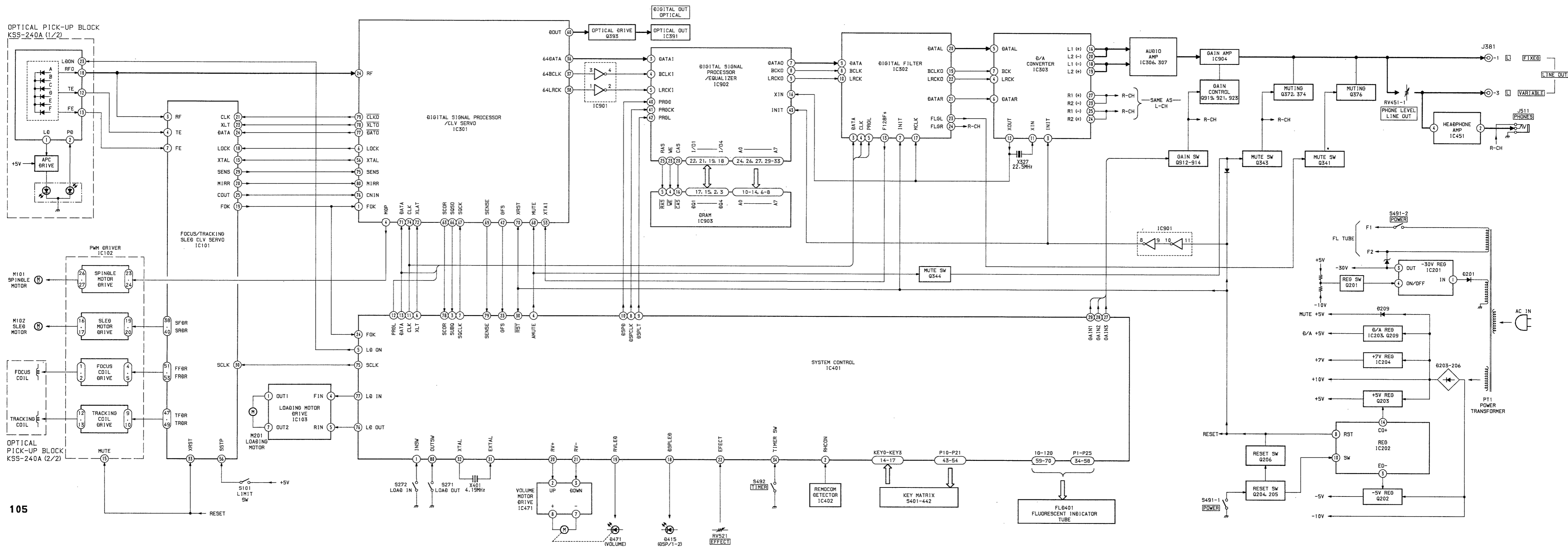

• Waveforms

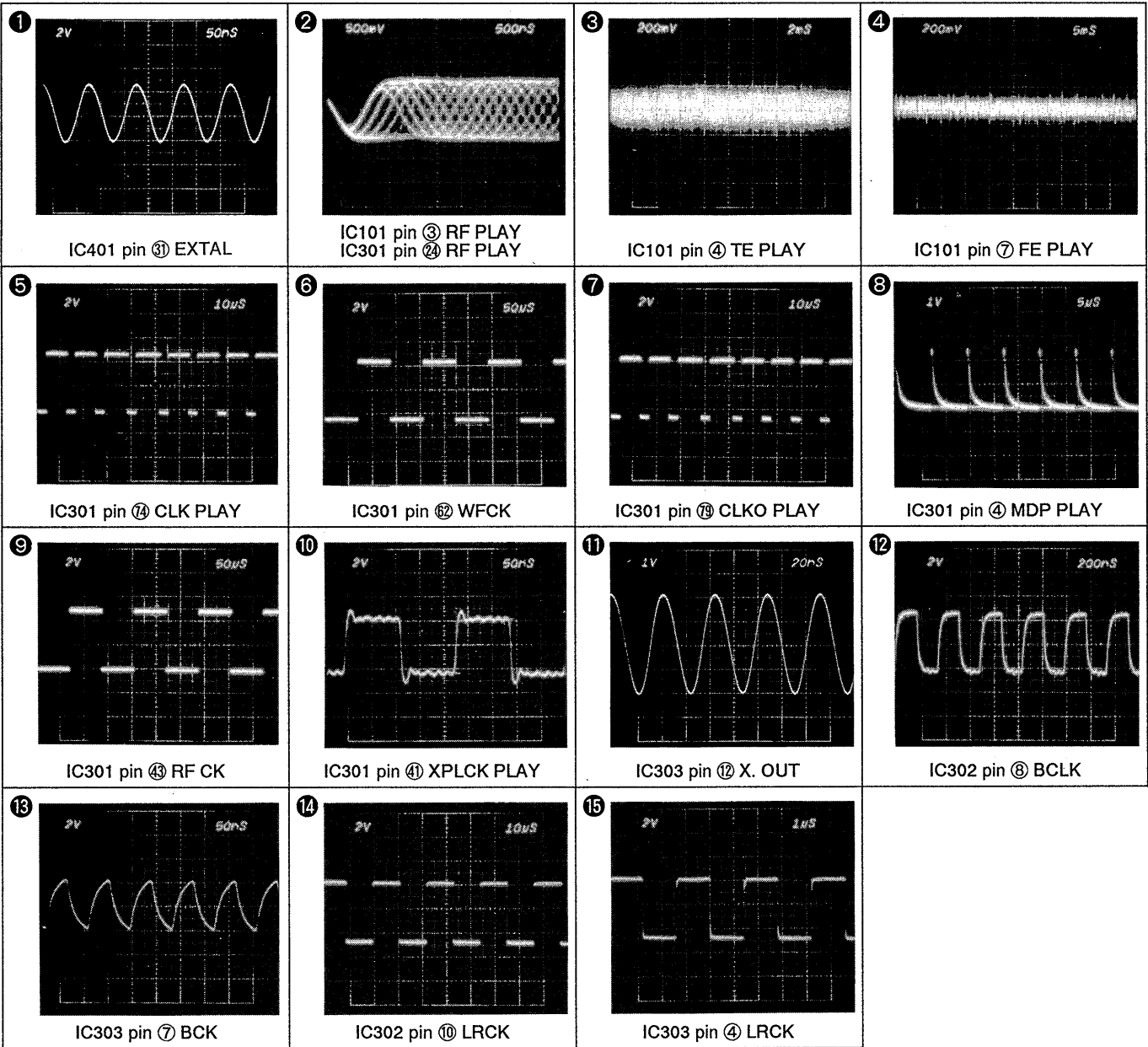

4-2. BD SECTION PRINTED WIRING BOARDS AND SCHEMATIC DIAGRAM

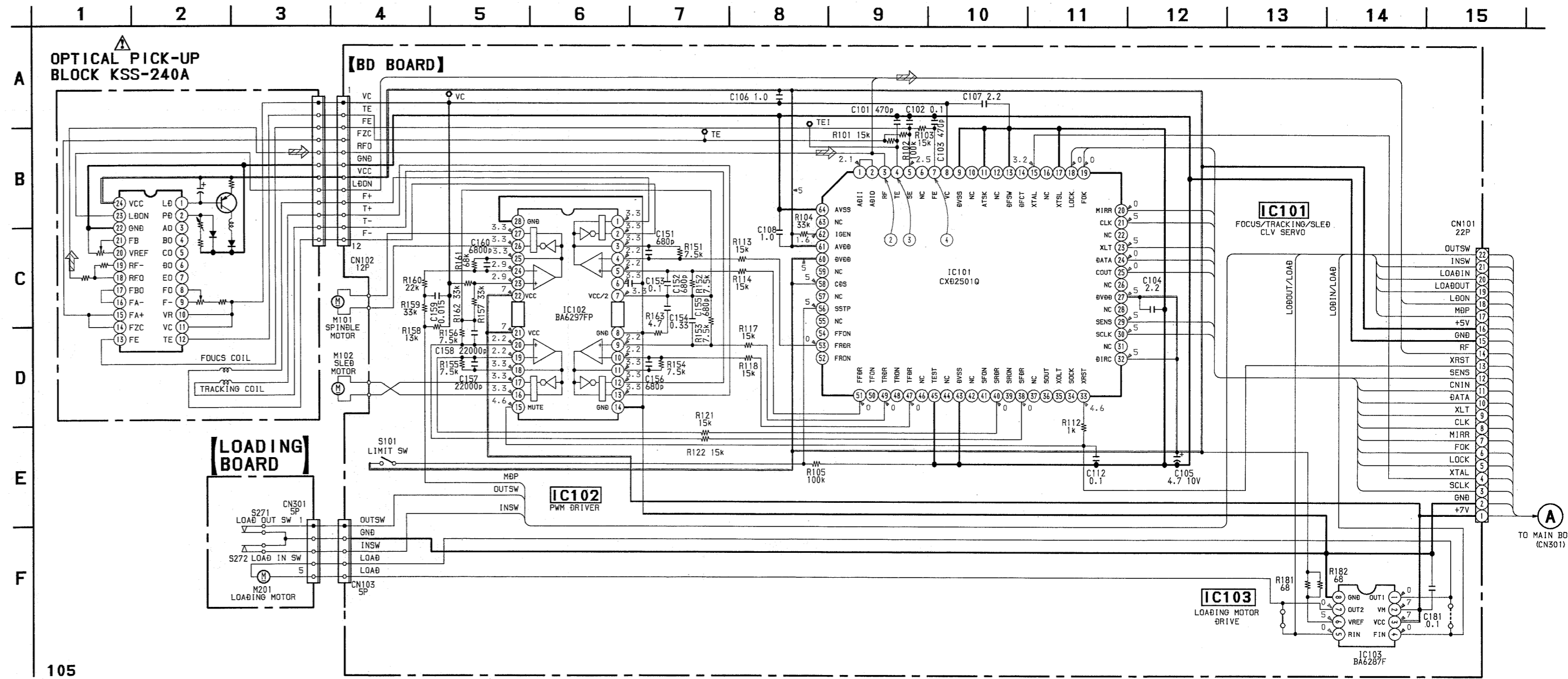
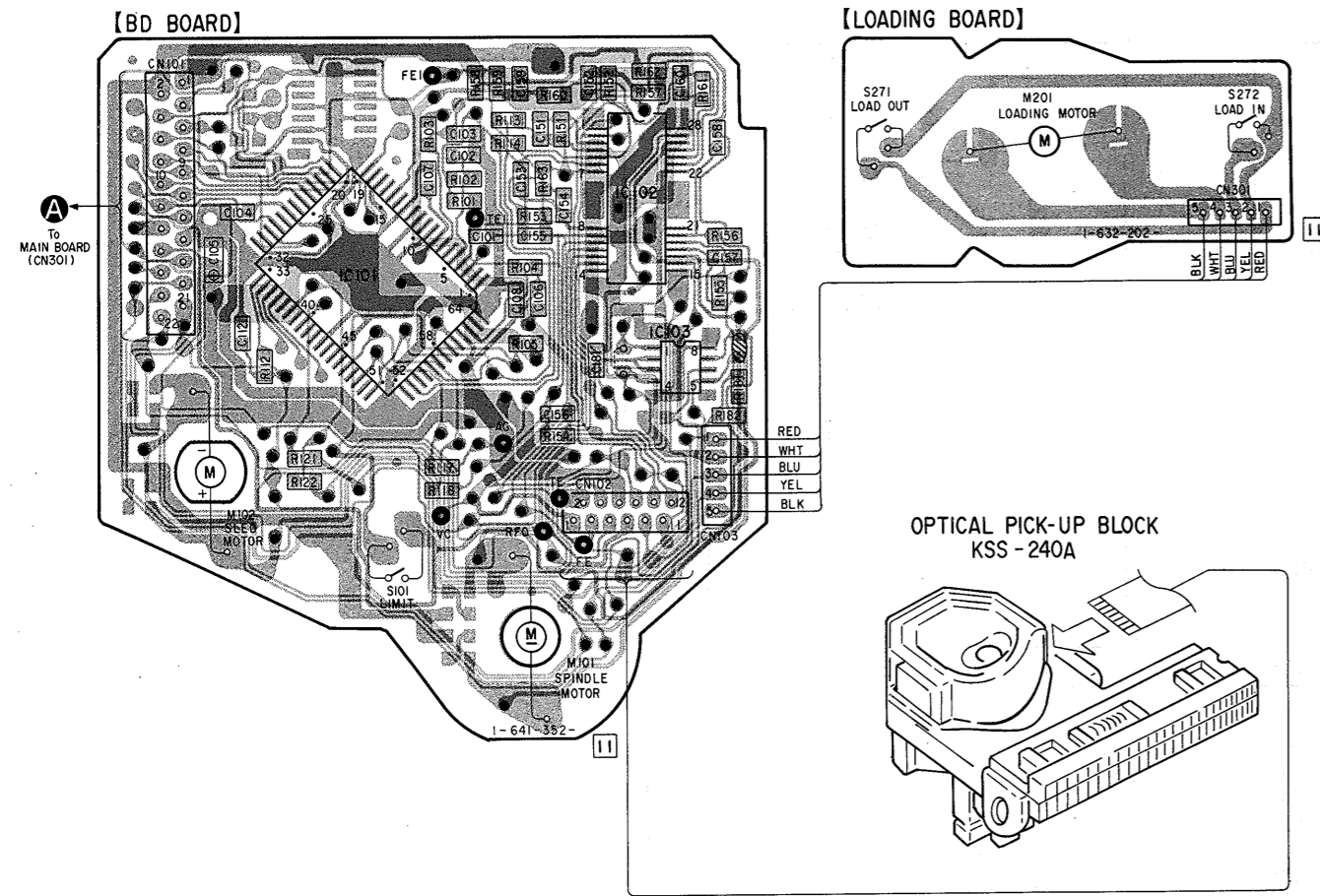

Note on Schematic Diagram:

- All capacitors are in μF unless otherwise noted. pF : $\mu\mu\text{F}$. 50 WV or less are not indicated except for electrolytics and tantalums.
- All resistors are in Ω and $\frac{1}{4} W$ or less unless otherwise specified.

Note on Printed Wiring Board:

- : parts extracted from the component side.
- : Through hole.
- ▨ : Pattern on the side which is seen.
- ▩ : Pattern of the rear side.

Note:
The components identified by mark Δ or dotted line with mark Δ are critical for safety. Replace only with part number specified.

Note:
Les composants identifiés par une marque Δ sont critiques pour la sécurité. Ne les remplacer que par une pièce portant le numéro spécifié.

- : B + Line.
- Voltages and waveforms are dc with respect to ground under no-signal conditions.
- Voltages are taken with a VOM (Input impedance 10 M Ω). Voltage variations may be noted due to normal production tolerances.
- Waveforms are taken with an oscilloscope. Voltage variations may be noted due to normal production tolerances.
- Circled numbers refer to waveforms.
- Signal path.
- ⇒ : CD

4-3. MAIN SECTION PRINTED WIRING BOARDS

Note on Schematic Diagram:

- All capacitors are in μF unless otherwise noted. μF : μF 50 WV or less are not indicated except for electrolytics and tantalums.
- All resistors are in Ω and $\frac{1}{4} W$ or less unless otherwise specified.
- Δ : internal component.

Note:
The components identified by mark Δ or dotted line with mark Δ are critical for safety. Replace only with part number specified.

Note:
Les composants identifiés par une marque Δ sont critiques pour la sécurité. Ne les remplacer que par une pièce portant le numéro spécifié.

- : B+ Line.
- - - : B- Line.
- Voltagés and waveforms are dc with respect to ground under no-signal conditions.
- Voltagés are taken with a VOM (input impedance 10 M Ω). Voltage variations may be noted due to normal production tolerances.
- Waveforms are taken with an oscilloscope. Voltage variations may be noted due to normal production tolerances.
- Circled numbers refer to waveforms.
- Signal path.
- \Rightarrow : CD
- \Rightarrow : digital out

Note on Printed Wiring Board:

- \bullet : parts extracted from the component side.
- \bullet : Pattern on the side which is seen.

Semiconductor Location

Ref. No.	Location	Ref. No.	Location
D201	E-19	IC402	B-2
D202	F-19	IC451	F-9
D203	E-18	IC471	F-10
D204	E-18	IC901	G-16
D205	E-18	IC902	H-15
D206	E-18	IC903	H-14
D208	F-17	IC904	C-15
D209	F-17		
D328	F-14	Q201	F-19
D344	H-14	Q202	H-18
D401	C-11	Q203	F-18
D402	C-10	Q204	G-19
D403	C-10	Q205	G-18
D404	C-10	Q206	F-18
D405	B-10	Q209	F-16
D406	B-9	Q341	E-13
D407	B-9	Q342	E-13
D408	B-9	Q343	E-13
D409	B-9	Q344	G-13
D410	B-9	Q371	B-14
D411	B-9	Q372	C-16
D412	B-9	Q373	B-14
D415	I-2	Q374	C-16
D471	F-11	Q375	B-14
		Q376	B-16
		Q393	B-14
IC201	F-19	Q912	D-13
IC202	G-18	Q913	D-13
IC203	G-16	Q914	D-13
IC204	F-18	Q919	C-14
IC301	I-17	Q920	D-16
IC302	G-15	Q921	C-14
IC303	F-15	Q922	D-16
IC306	D-15	Q923	C-14
IC307	C-15	Q924	C-16
IC391	A-14		
IC401	C-9		

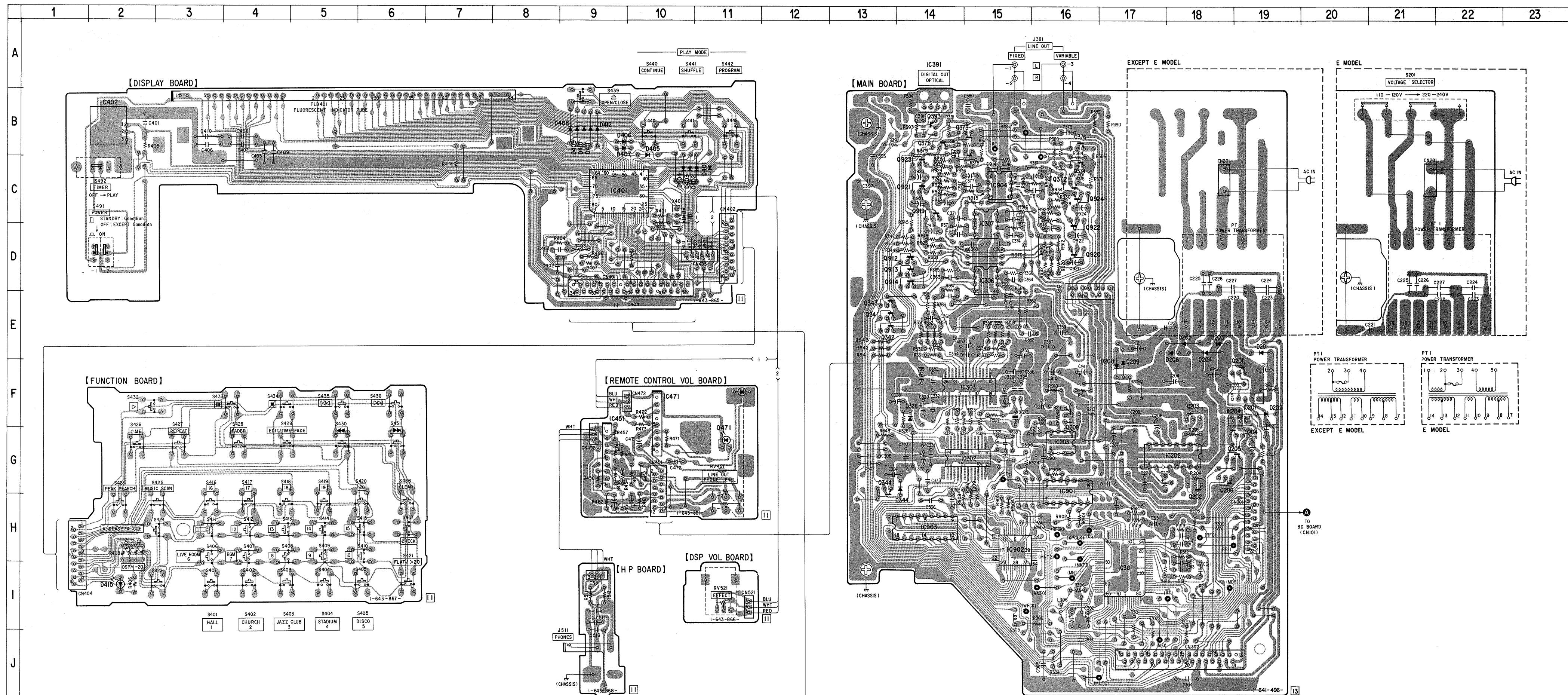

• Semiconductor Lead Layouts

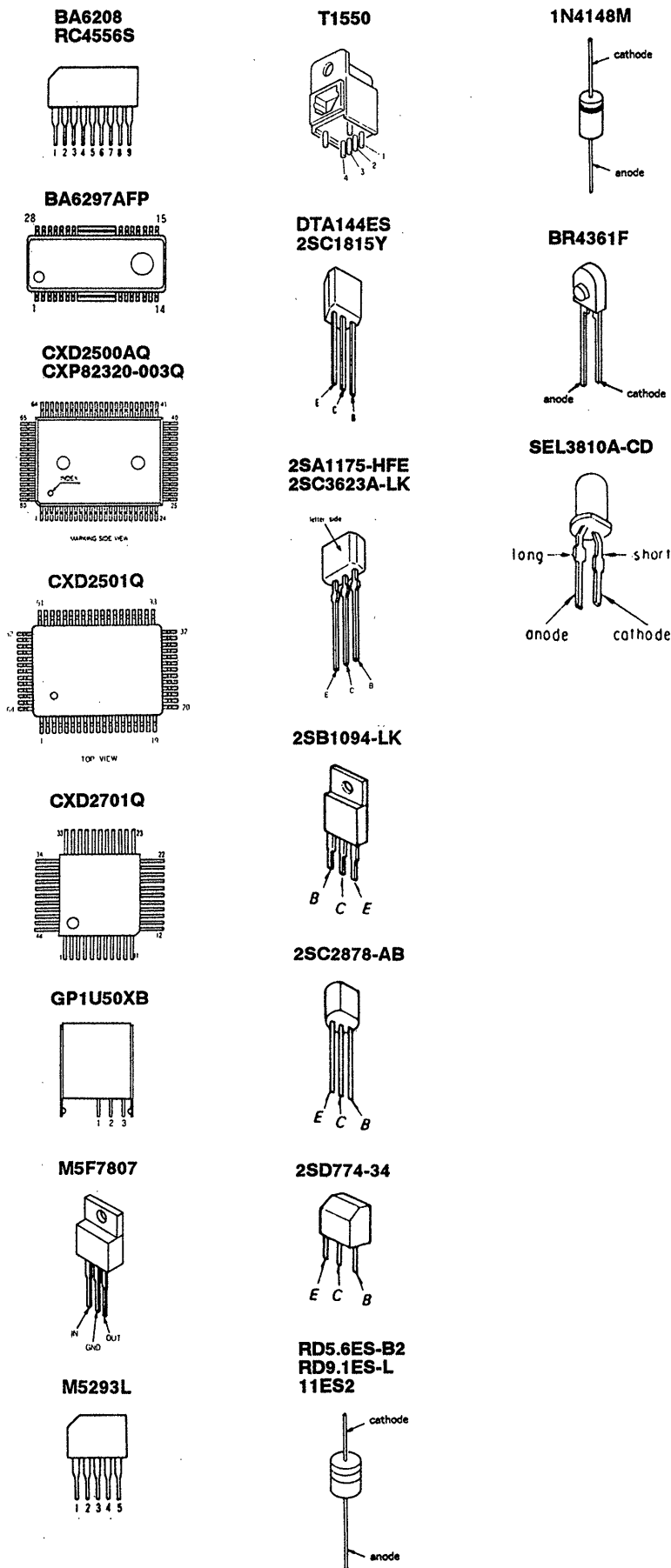

• IC Block Diagrams

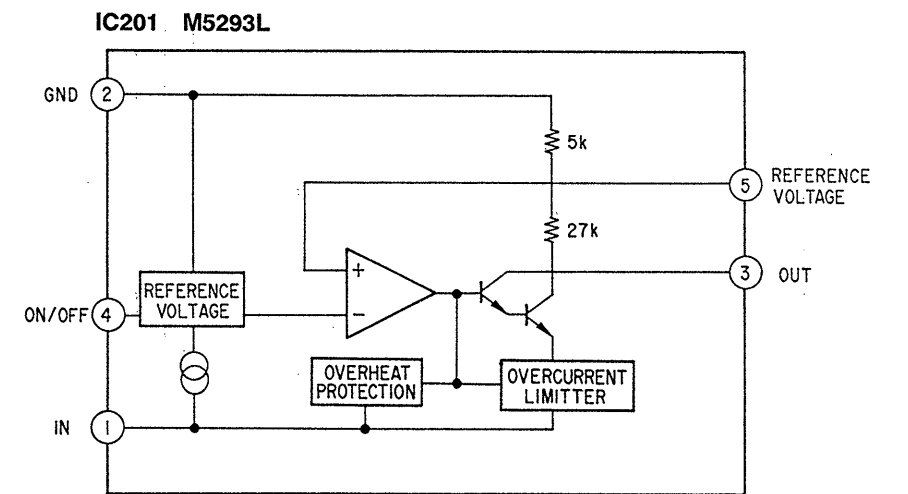
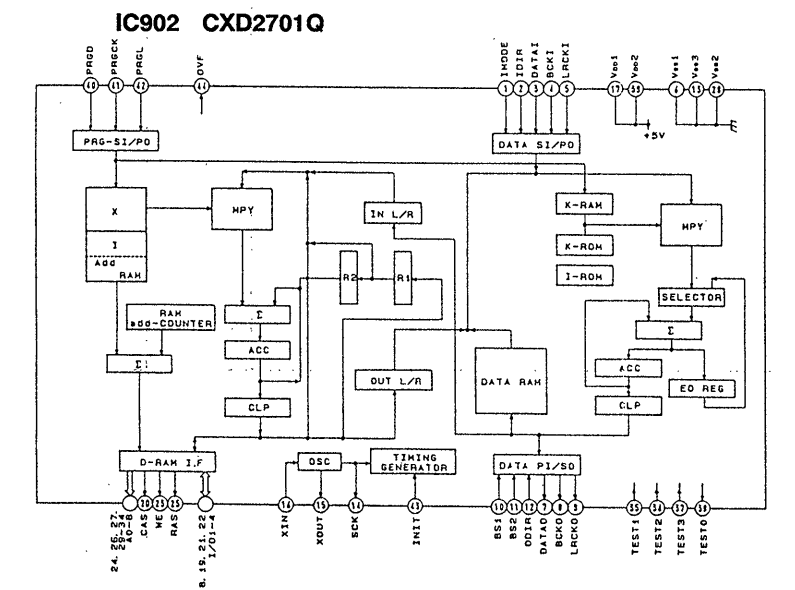
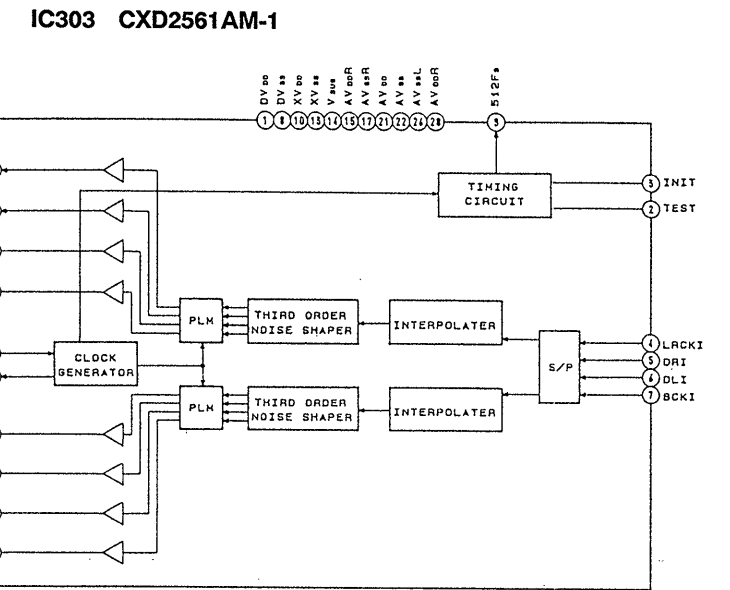
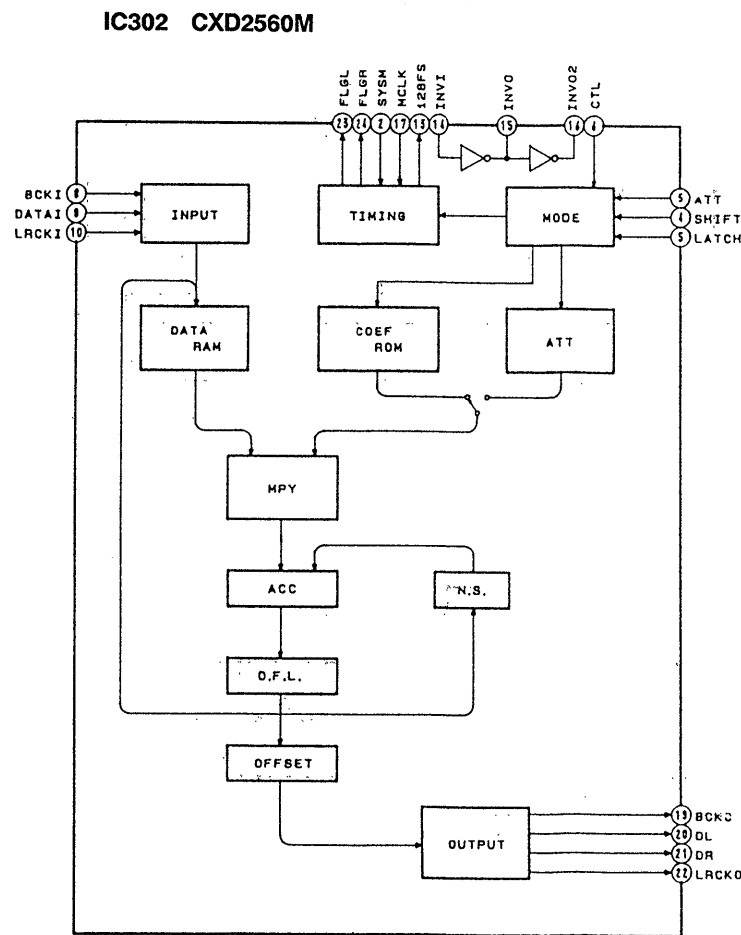
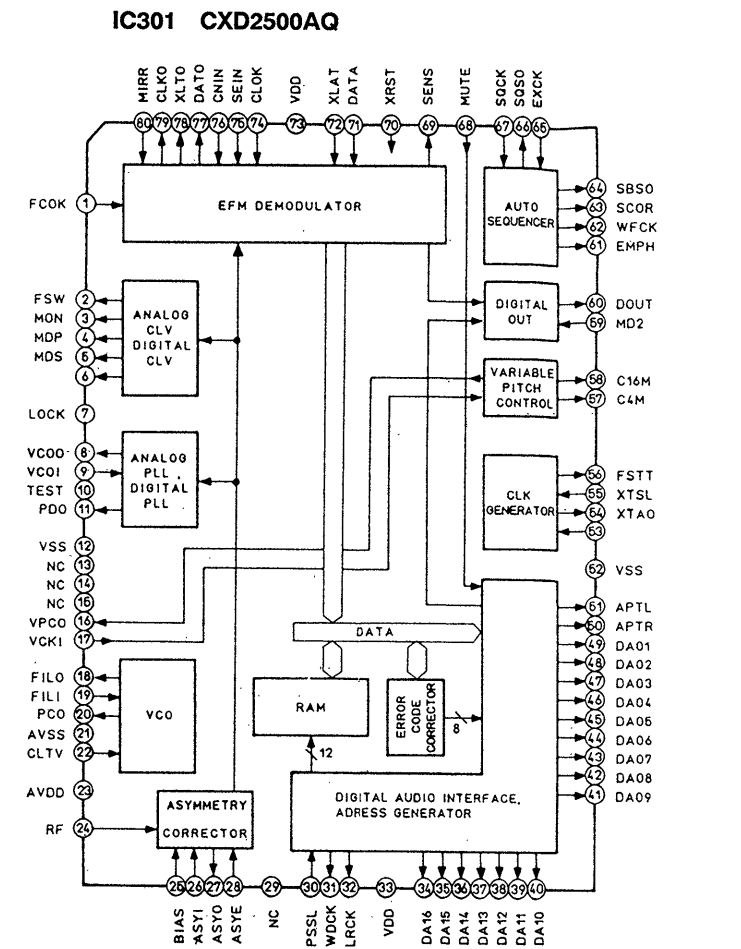
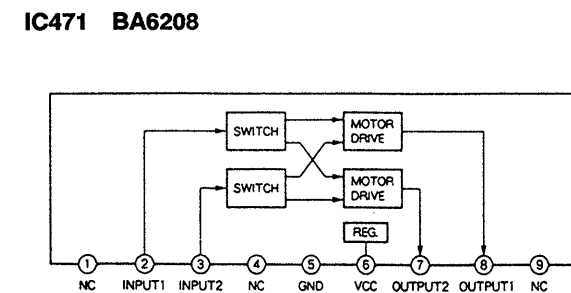
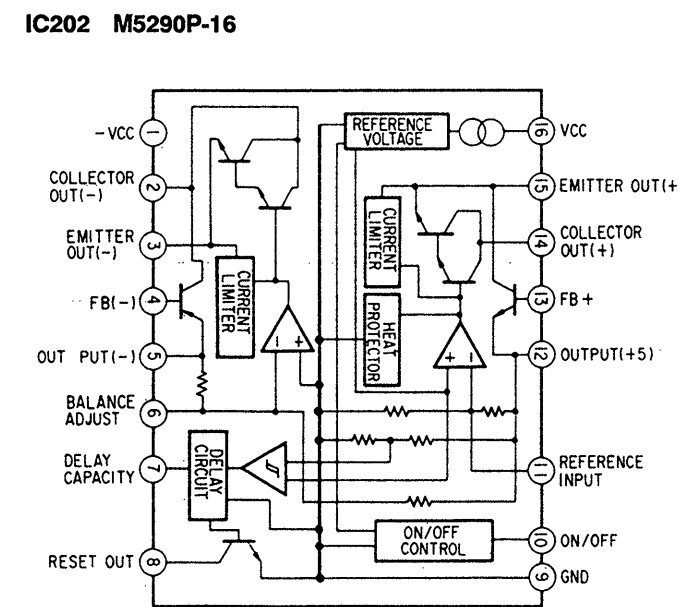
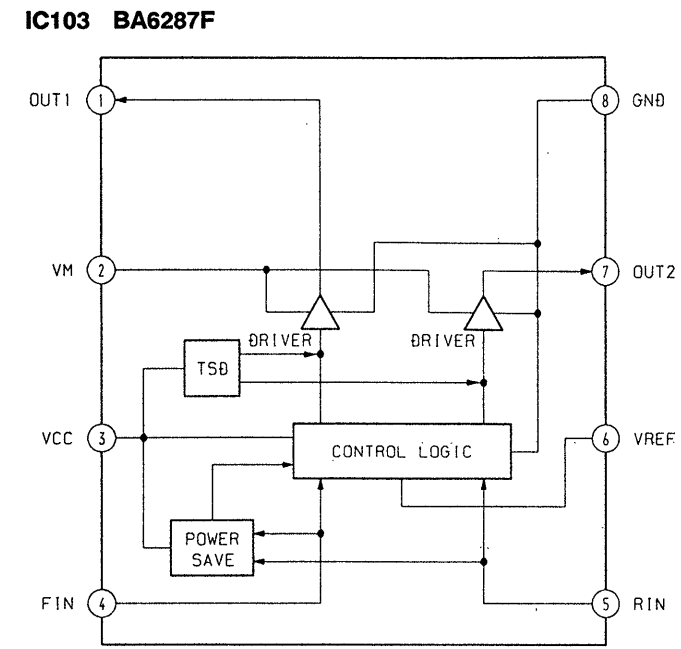

SECTION 5 EXPLODED VIEWS

NOTE:

- -XX and -X mean standardized parts, so they may have some difference from the original one.
- Color Indication of Appearance Parts
Example:
KNOB, BALANCE (WHITE) ... (RED)

↑ Parts Color ↑ Cabinet's Color
- Items marked "*" are not stocked since they are seldom required for routine service. Some delay should be anticipated when ordering these items.
- The mechanical parts with no reference number in the exploded views are not supplied.
- Hardware (# mark) list is given in the last of this parts list.

The components identified by mark Δ or dotted line with mark Δ are critical for safety. Replace only with part number specified.

Les composants identifiés par une marque Δ sont critiques pour la sécurité. Ne les remplacer que par une pièce portant le numéro spécifié.

(1) FRONT PANEL ASS'Y AND CASE SECTION

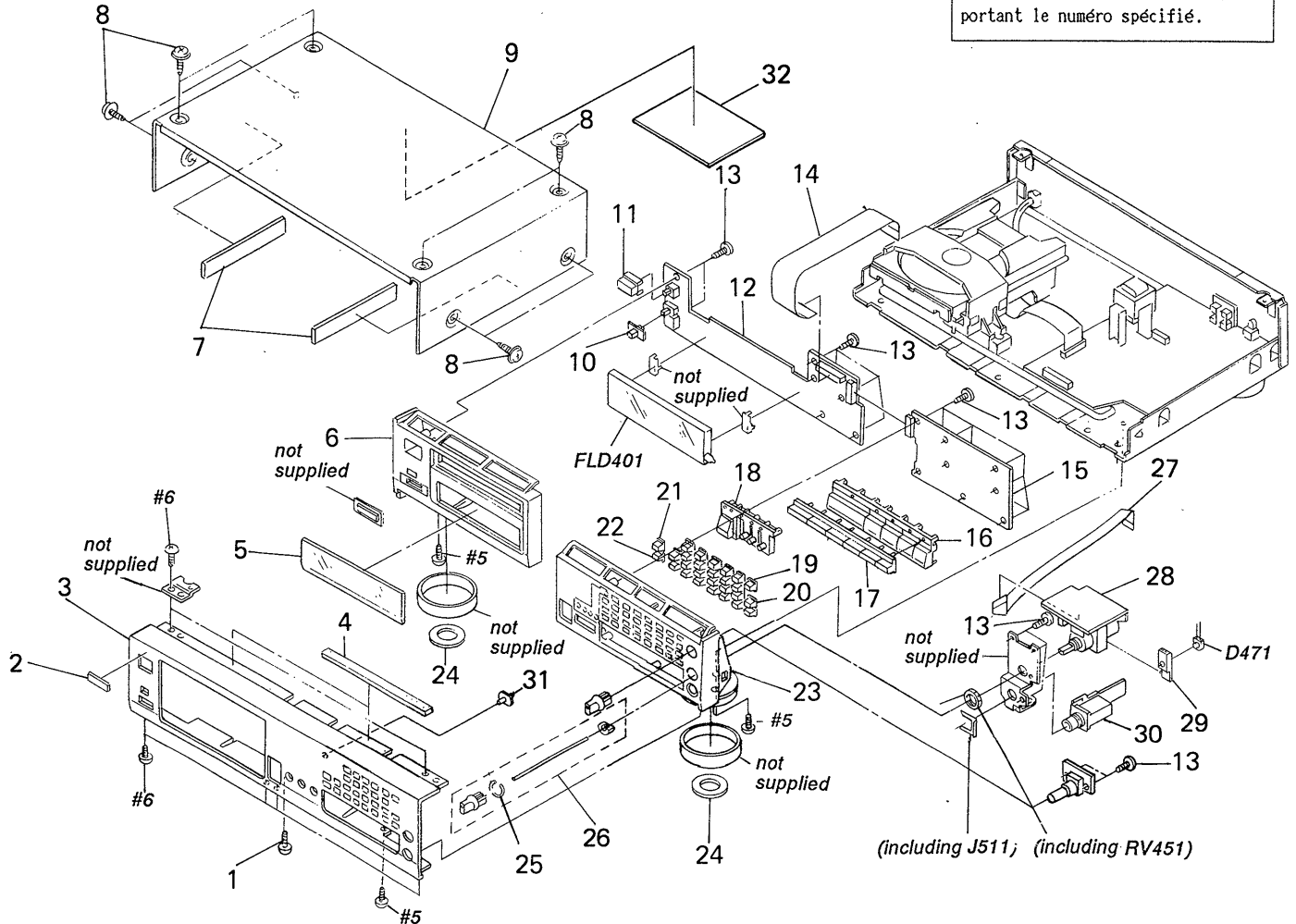

Ref. No.	Part No.	Description	Remark
1	3-703-685-21	SCREW (+BV 3X8)	
2	4-908-848-01	EMBLEM, SONY	
3	4-949-195-01	PANEL (FRONT) (AEP, E, AUS)	
3	4-949-195-11	PANEL (FRONT) (CND)	
* 4	4-929-557-01	CUSHION (PANEL)	
5	4-949-193-01	PLATE, INDICATION	
6	X-4942-163-1	PANEL (BASE) (L) ASSY (AEP, E, AUS)	
6	X-4942-165-1	PANEL (BASE) (L) ASSY (CND)	
* 7	4-929-561-01	CUSHION (CASE)	
8	3-704-366-01	SCREW (CASE) (M3X8)	
9	4-929-529-01	CASE	
10	4-922-518-11	KNOB (TIMER)	
11	4-947-034-03	BUTTON (POWER)	
* 12	A-4649-137-A	DISP BOARD, COMPLETE	
13	4-951-620-01	SCREW (2. 6X8), +BVTP	
14	1-690-923-11	WIRE (FLAT TYPE) (35 CORE)	
* 15	1-643-867-11	FUNCTION BOARD	
16	4-949-243-01	BUTTON (L)	

Ref. No.	Part No.	Description	Remark
17	4-947-582-11	BUTTON (S)	
18	4-949-191-01	BUTTON (O/C)	
19	4-947-574-01	BUTTON (MC1)	
20	4-947-575-01	BUTTON (MC2)	
20	4-947-576-01	BUTTON (MC3)	
21	4-947-577-01	BUTTON (MC4)	
23	X-4941-940-1	PANEL (BASE) (R) ASSY (AEP, E, AUS)	
23	X-4942-167-1	PANEL (BASE) (R) ASSY (CND)	
24	4-923-836-11	CUSHION	
25	4-948-469-01	SPRING, RING	
26	A-4604-901-A	KNOB (HP) ASSY	
27	1-690-392-11	WIRE, FLAT TYPE (13 CORE)	
* 28	1-643-864-11	REMOTE CONTROL VOL BOARD	
* 29	4-922-980-01	HOLDER (LED)	
* 30	1-643-868-11	HP BOARD	
31	4-951-617-01	INDICATOR	
* 32	4-922-943-01	DUMPER	
* 33	1-643-866-11	DSP VOL BOARD	

34	4-948-345-01	KNOB (VOL)	
D471	8-719-970-49	DIODE BR4361F	
FLD401	1-519-696-11	INDICATOR TUBE, FLUORESCENT	

(2) CHASSIS SECTION

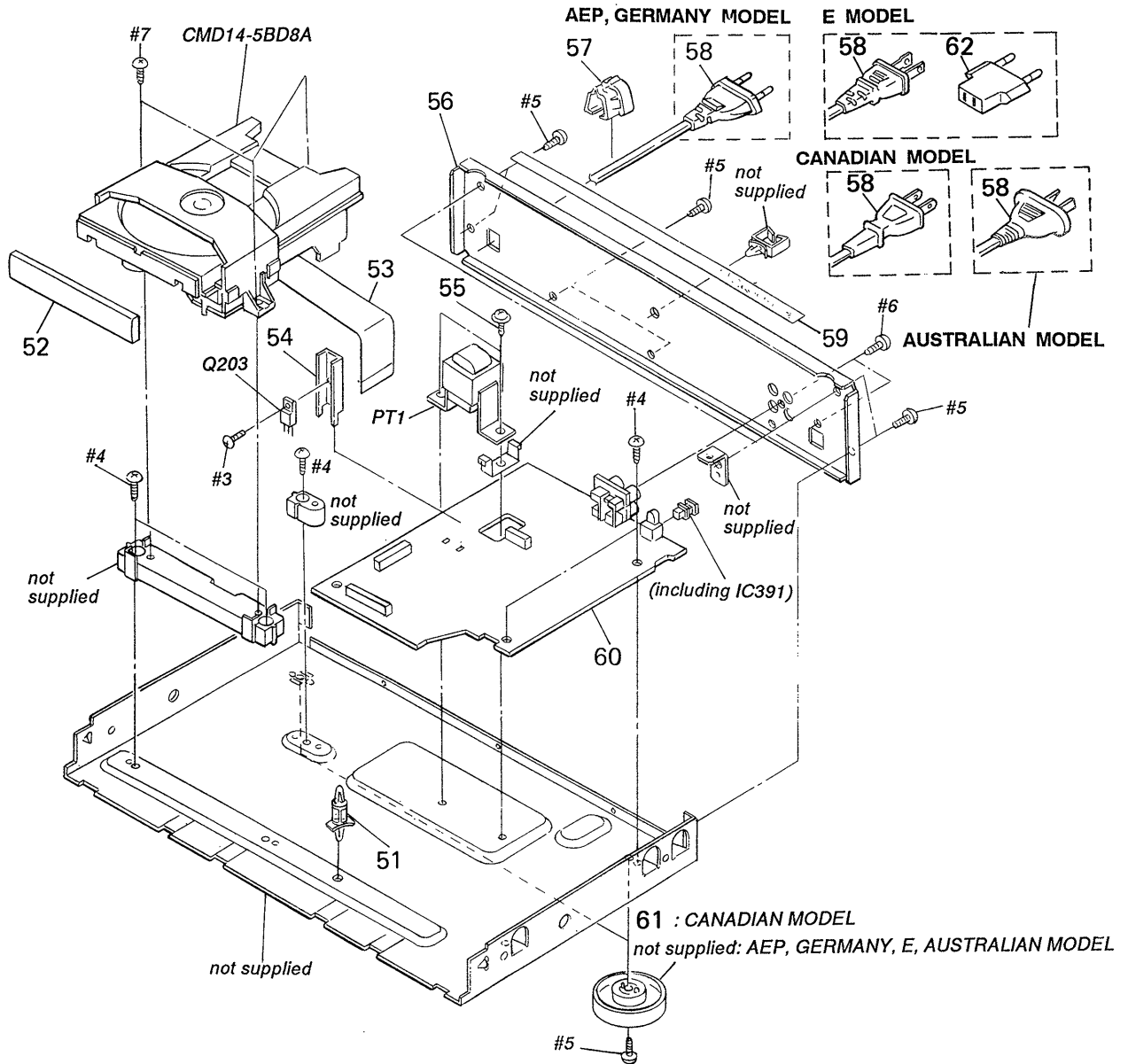

Ref. No.	Part No.	Description	Remark
* 51	4-924-098-01	HOLDER, PC BOARD	
52	4-947-167-01	PANEL, LOADING	
53	1-575-002-11	WIRE, FLAT TYPE (22 CORE)	
* 54	4-941-237-01	HEAT SINK	
55	4-886-821-11	SCREW, S TIGHT, +PTTW 3X6	
* 56	4-949-176-01	PANEL, BACK (AEP)	
* 56	4-949-176-11	PANEL, BACK (AEP)	
* 56	4-949-176-21	PANEL, BACK (AUS)	
* 56	4-949-176-32	PANEL, BACK (CND)	
* 56	4-949-176-42	PANEL, BACK (E)	
* 57	3-703-244-00	BUSHING (2104), CORD (CND, AEP, AUS)	
* 57	3-703-571-11	BUSHING (S) (4516), CORD (E)	

Ref. No.	Part No.	Description	Remark
△58	1-558-943-41	CORD, POWER (E)	
△58	1-574-358-31	CORD, POWER (WITH CONNECTOR) (AUS)	
△58	1-575-651-21	CORD, POWER (AEP)	
△58	1-590-836-11	CORD, POWER (CND)	
* 59	4-927-653-01	SHEET (F/P)	
* 60	A-4649-140-A	MAIN BOARD, COMPLETE (CND, AEP, AUS)	
* 60	A-4649-253-A	MAIN BOARD, COMPLETE (E)	
61	4-943-148-32	FOOT (F58175SW) (CND)	
△62	1-569-007-11	ADAPTER, CONVERSION 2P (E)	
△PT1	1-449-921-11	TRANSFORMER, POWER (CND)	
△PT1	1-449-922-11	TRANSFORMER, POWER (AEP, AUS)	
△PT1	1-449-923-11	TRANSFORMER, POWER (E)	
Q203	8-729-141-83	TRANSISTOR 2SB1094-LK	

The components identified by mark △ or dotted line with mark. △ are critical for safety. Replace only with part number specified.

Les composants identifiés par une marque △ sont critiques pour la sécurité. Ne les remplacer que par une pièce portant le numéro spécifié.

(3) CD MECHANISM SECTION (CDM14-5BD8A)

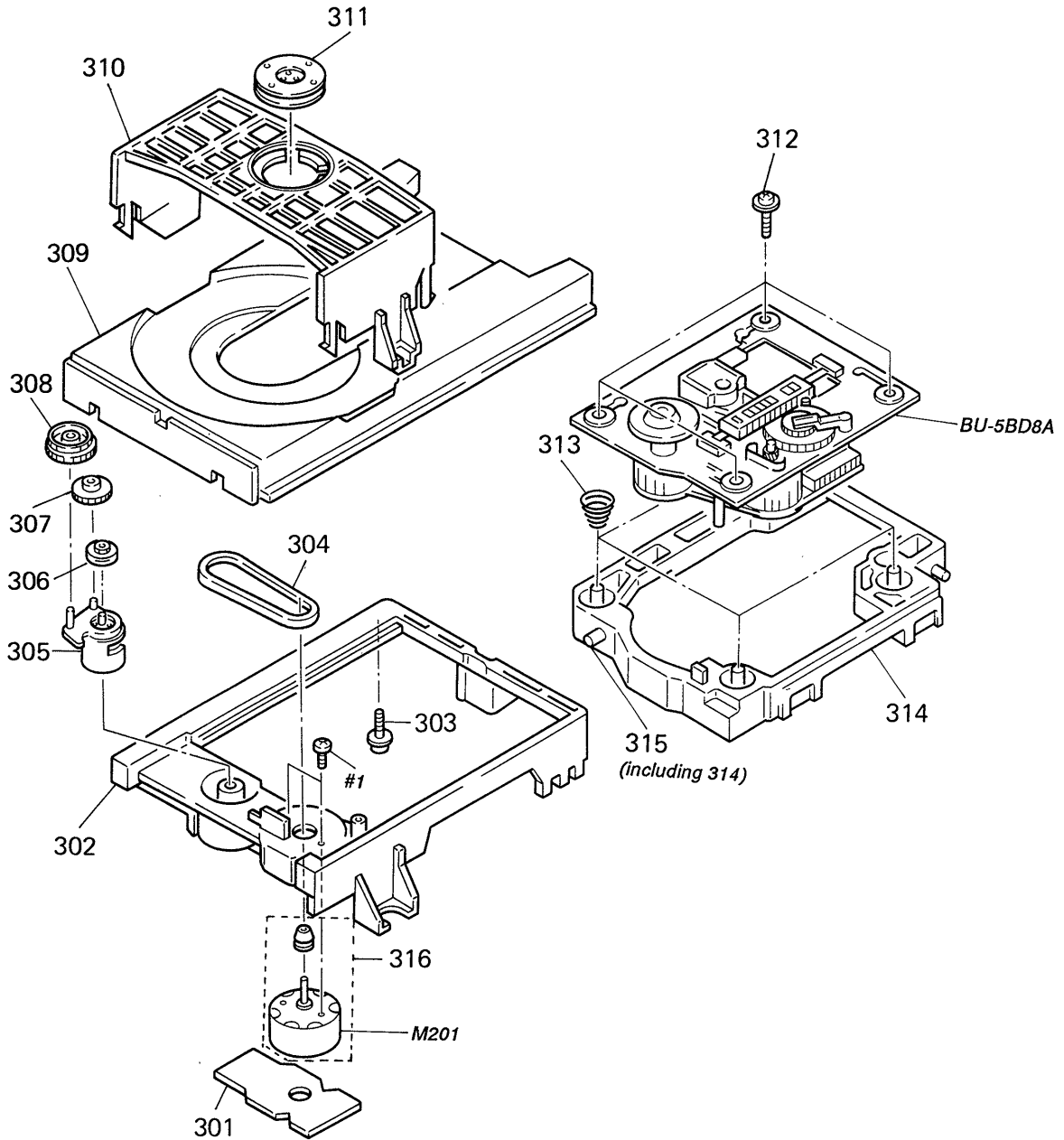

Part No.	Description	Remark
* 301	1-632-202-11 LOADING BOARD	
302	4-933-111-01 CHASSIS (MD)	
* 303	4-917-583-21 BRACKET, YOKE	
304	4-927-649-01 BELT	
305	4-933-109-01 CAM	
306	4-927-651-01 PULLEY (S)	
307	4-927-628-01 GEAR (C)	
308	4-933-107-01 GEAR (PL)	
309	4-933-112-01 TABLE, DISK	
310	4-933-110-01 HOLDER (MG)	

Ref. No.	Part No.	Description	Remark
* 311	1-452-538-11	MAGNET	
	312	4-933-134-01 SCREW (+PTPHW M2. 6X6)	
	313	4-948-503-01 SPRING (BU), COMPRESSION	
	314	4-933-129-04 HOLDER (BU)	
	315	4-933-108-01 SHAFT (CAM)	
	316	A-4604-363-A MOTOR (L) ASSY	
	M201	1-541-632-11 MOTOR, DC (LOADING)	

(4) OPTICAL PICK-UP BLOCK (BU-5BD8A)

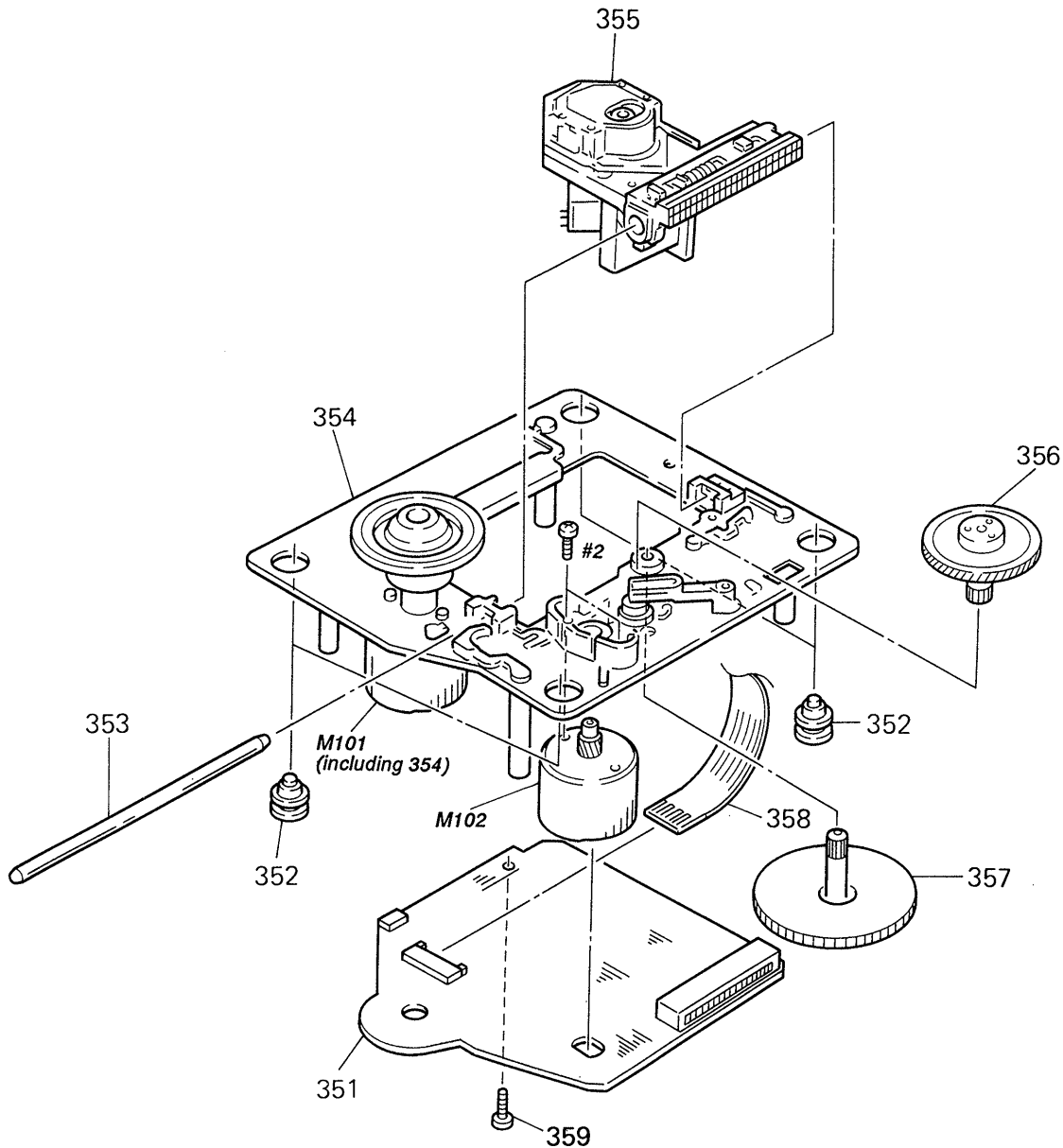

Ref. No.	Part No.	Description	Remark
* 351	A-4617-977-A	BD BOARD, COMPLETE	
352	4-933-126-01	INSULATOR (A)	
353	4-917-565-01	SHAFT, SLED	
354	X-4917-523-3	BASE ASSY (OUTSERT) (Including M101)	
△355	8-848-144-11	PICK-UP, OPTICAL KSS-240A	

Ref. No.	Part No.	Description	Remark
356	4-917-567-01	GEAR (M)	
357	4-917-564-01	GEAR (P), FLATNESS	
358	1-575-001-11	WIRE, FLAT TYPE (12 CORE)	
359	4-951-620-01	SCREW (2.6X8), +BVTP	
M102	X-4917-504-1	MOTOR ASSY (SLED)	

<p>The components identified by mark △ or dotted line with mark △ are critical for safety. Replace only with part number specified.</p>	<p>Les composants identifiés par une marque △ sont critiques pour la sécurité. Ne les remplacer que par une pièce portant le numéro spécifié.</p>
---	---

SECTION 6 ELECTRICAL PARTS LIST

BD

NOTE:

- Due to standardization, replacements in the parts list may be different from the parts specified in the diagrams or the components used on the set.
- -XX and -X mean standardized parts, so they may have some difference from the original one.
- RESISTORS
All resistors are in ohms.
METAL: Metal-film resistor.
METAL OXIDE: Metal oxide-film resistor.
F: Nonflammable

- Items marked "*" are not stocked since they are seldom required for routine service. Some delay should be anticipated when ordering these items.
- SEMICONDUCTORS
In each case, u: μ , for example:
uA ..: μ A. uPA..: μ PA.
uPB..: μ PB. uPC..: μ PC. uPD..: μ PD.
- CAPACITORS
uF: μ F
- COILS
uH: μ H

The components identified by mark Δ or dotted line with mark Δ are critical for safety. Replace only with part number specified.

Les composants identifiés par une marque Δ sont critiques pour la sécurité. Ne les remplacer que par une pièce portant le numéro spécifié.

When indicating parts by reference number, please include the board.

Ref. No.	Part No.	Description	Remark	Ref. No.	Part No.	Description	Remark
* A-4617-977-A BD BOARD, COMPLETE *****				< RESISTOR >			
< CAPACITOR >				R101	1-216-077-00	METAL CHIP	15K 5% 1/10W
C101	1-163-005-11	CERAMIC CHIP	470PF 10% 50V	R102	1-216-097-00	METAL CHIP	100K 5% 1/10W
C102	1-163-038-00	CERAMIC CHIP	0.1uF 25V	R103	1-216-077-00	METAL CHIP	15K 5% 1/10W
C103	1-163-005-11	CERAMIC CHIP	470PF 10% 50V	R104	1-216-085-00	METAL CHIP	33K 5% 1/10W
C104	1-164-505-11	CERAMIC CHIP	2.2uF 16V	R105	1-216-097-00	METAL CHIP	100K 5% 1/10W
C105	1-135-155-21	TANTALUM CHIP	4.7uF 10% 16V	R112	1-216-049-00	METAL CHIP	1K 5% 1/10W
C106	1-164-346-11	CERAMIC CHIP	1uF 16V	R113	1-216-077-00	METAL CHIP	15K 5% 1/10W
C107	1-164-505-11	CERAMIC CHIP	2.2uF 16V	R114	1-216-077-00	METAL CHIP	15K 5% 1/10W
C108	1-164-346-11	CERAMIC CHIP	1uF 16V	R117	1-216-077-00	METAL CHIP	15K 5% 1/10W
C112	1-163-038-00	CERAMIC CHIP	0.1uF 25V	R118	1-216-077-00	METAL CHIP	15K 5% 1/10W
C151	1-163-007-11	CERAMIC CHIP	680PF 10% 50V	R121	1-216-077-00	METAL CHIP	15K 5% 1/10W
C152	1-163-007-11	CERAMIC CHIP	680PF 10% 50V	R122	1-216-077-00	METAL CHIP	15K 5% 1/10W
C153	1-163-038-00	CERAMIC CHIP	0.1uF 25V	R151	1-216-070-00	METAL CHIP	7.5K 5% 1/10W
C154	1-164-336-11	CERAMIC CHIP	0.33uF 25V	R152	1-216-070-00	METAL CHIP	7.5K 5% 1/10W
C155	1-163-007-11	CERAMIC CHIP	680PF 10% 50V	R153	1-216-070-00	METAL CHIP	7.5K 5% 1/10W
C156	1-163-007-11	CERAMIC CHIP	680PF 10% 50V	R154	1-216-070-00	METAL CHIP	7.5K 5% 1/10W
C157	1-163-037-11	CERAMIC CHIP	0.022uF 10% 25V	R155	1-216-070-00	METAL CHIP	7.5K 5% 1/10W
C158	1-163-037-11	CERAMIC CHIP	0.022uF 10% 25V	R156	1-216-070-00	METAL CHIP	7.5K 5% 1/10W
C159	1-163-023-00	CERAMIC CHIP	0.015uF 5% 50V	R157	1-216-085-00	METAL CHIP	33K 5% 1/10W
C160	1-163-019-00	CERAMIC CHIP	0.0068uF 10% 50V	R158	1-216-076-00	METAL CHIP	13K 5% 1/10W
C181	1-163-038-00	CERAMIC CHIP	0.1uF 25V	R159	1-216-085-00	METAL CHIP	33K 5% 1/10W
< CONNECTOR >				R160	1-216-081-00	METAL CHIP	22K 5% 1/10W
CN101	1-568-796-11	SOCKET, CONNECTOR 22P		R161	1-216-093-00	METAL CHIP	68K 5% 1/10W
CN102	1-568-795-11	SOCKET, CONNECTOR 12P		R162	1-216-085-00	METAL CHIP	33K 5% 1/10W
CN103	1-564-721-11	PIN, CONNECTOR (SMALL TYPE) 5P		R163	1-216-308-00	METAL CHIP	4.7 5% 1/10W
< IC >				R181	1-216-021-00	METAL CHIP	68 5% 1/10W
IC101	8-752-344-48	IC	CXD2501Q	R182	1-216-021-00	METAL CHIP	68 5% 1/10W
IC102	8-759-071-80	IC	BA6297AFP	< SWITCH >			
IC103	8-759-040-83	IC	BA6287F	S101	1-572-085-11	SWITCH, LEAF (LIMIT)	

DISP	DSP VOL	FUNCTION
------	---------	----------

Ref. No.	Part No.	Description	Remark	Ref. No.	Part No.	Description	Remark
*	A-4649-137-A	DISP BOARD, COMPLETE *****		R407	1-249-429-11	CARBON 10K 5% 1/4W	
		< CAPACITOR >		R408	1-249-435-11	CARBON 33K 5% 1/4W	
C401	1-164-159-11	CERAMIC 0.1uF	50V	R411	1-249-417-11	CARBON 1K 5% 1/4W	
C402	1-164-159-11	CERAMIC 0.1uF	50V	R414	1-249-441-11	CARBON 100K 5% 1/4W	
C403	1-164-159-11	CERAMIC 0.1uF	50V			< SWITCH >	
C404	1-164-159-11	CERAMIC 0.1uF	50V	S439	1-554-303-21	SWITCH, TACTILE (△ OPEN/CLOSE)	
C405	1-164-159-11	CERAMIC 0.1uF	50V	S440	1-554-303-21	SWITCH, TACTILE (CONTINUE)	
C406	1-164-159-11	CERAMIC 0.1uF	50V	S441	1-554-303-21	SWITCH, TACTILE (SHUFFLE)	
C407	1-164-159-11	CERAMIC 0.1uF	50V	S442	1-554-303-21	SWITCH, TACTILE (PROGRAM)	
C408	1-164-159-11	CERAMIC 0.1uF	50V	S491	1-554-118-00	SWITCH, PUSH (1 KEY) (POWER)	
C409	1-164-159-11	CERAMIC 0.1uF	50V	S492	1-570-157-51	SWITCH, SLIDE (TIMER)	
C410	1-164-159-11	CERAMIC 0.1uF	50V			< CRYSTAL >	
		< CONNECTOR >		X401	1-579-175-11	VIBRATOR, CERAMIC (4.19MHz)	
* CN401	1-691-958-11	SOCKET, CONNECTOR 35P		*****			
* CN402	1-691-188-11	CONNECTOR, BOARD TO BOARD 18P		*	1-643-866-11	DSP VOL BOARD *****	
* CN403	1-564-708-11	PIN, CONNECTOR (SMALL TYPE) 6P				< CONNECTOR >	
		< DIODE >		* CN521	1-564-705-11	PIN, CONNECTOR (SMALL TYPE) 3P	
D401	8-719-987-63	DIODE 1N4148M				< VARIABLE RESISTOR >	
D402	8-719-987-63	DIODE 1N4148M		RV521	1-241-738-11	RES, VAR, CARBON 10K (EFFECT)	
D403	8-719-987-63	DIODE 1N4148M		*****			
D404	8-719-987-63	DIODE 1N4148M		*	1-643-867-11	FUNCTION BOARD *****	
D405	8-719-987-63	DIODE 1N4148M				< CONNECTOR >	
D406	8-719-987-63	DIODE 1N4148M		* CN404	1-691-187-11	CONNECTOR, BOARD TO BOARD 18P	
D407	8-719-987-63	DIODE 1N4148M				< DIODE >	
D408	8-719-987-63	DIODE 1N4148M		D415	8-719-313-72	DIODE SEL3810A-CD	
D409	8-719-987-63	DIODE 1N4148M				< RESISTOR >	
D410	8-719-987-63	DIODE 1N4148M		R406	1-249-399-11	CARBON 330 5% 1/4W	
D411	8-719-987-63	DIODE 1N4148M		R408	1-249-435-11	CARBON 33K 5% 1/4W	
D412	8-719-987-63	DIODE 1N4148M		R409	1-249-435-11	CARBON 33K 5% 1/4W	
		< INDICATOR TUBE >		R410	1-249-435-11	CARBON 33K 5% 1/4W	
FLD401	1-519-696-11	INDICATOR TUBE, FLUORESCENT		R412	1-249-435-11	CARBON 33K 5% 1/4W	
		< IC >				< SWITCH >	
IC401	8-752-834-34	IC CXP82320-003Q		S401	1-554-303-21	SWITCH, TACTILE (HALL/1)	
IC402	8-749-922-36	IC GP1U50XB		S402	1-554-303-21	SWITCH, TACTILE (CHURCH/2)	
		< RESISTOR >		S403	1-554-303-21	SWITCH, TACTILE (JAZZ CLUB/3)	
R401	1-249-429-11	CARBON 10K 5% 1/4W		S404	1-554-303-21	SWITCH, TACTILE (STADIUM/4)	
R402	1-249-429-11	CARBON 10K 5% 1/4W		S405	1-554-303-21	SWITCH, TACTILE (DISCO/5)	
R403	1-249-425-11	CARBON 4.7K 5% 1/4W					
R404	1-249-425-11	CARBON 4.7K 5% 1/4W					
R405	1-249-425-11	CARBON 4.7K 5% 1/4W					
R406	1-249-429-11	CARBON 10K 5% 1/4W					

FUNCTION HP LOADING MAIN

Ref. No.	Part No.	Description	Remark
S406	1-554-303-21	SWITCH, TACTILE (LIVE ROOM/6)	
S407	1-554-303-21	SWITCH, TACTILE (BGM/7)	
S408	1-554-303-21	SWITCH, TACTILE (8)	
S409	1-554-303-21	SWITCH, TACTILE (9)	
S410	1-554-303-21	SWITCH, TACTILE (10)	
S411	1-554-303-21	SWITCH, TACTILE (11)	
S412	1-554-303-21	SWITCH, TACTILE (12)	
S413	1-554-303-21	SWITCH, TACTILE (13)	
S414	1-554-303-21	SWITCH, TACTILE (14)	
S415	1-554-303-21	SWITCH, TACTILE (15)	
S416	1-554-303-21	SWITCH, TACTILE (16)	
S417	1-554-303-21	SWITCH, TACTILE (17)	
S418	1-554-303-21	SWITCH, TACTILE (18)	
S419	1-554-303-21	SWITCH, TACTILE (19)	
S420	1-554-303-21	SWITCH, TACTILE (20)	
S421	1-554-303-21	SWITCH, TACTILE (FLAT>20)	
S422	1-554-303-21	SWITCH, TACTILE (DSP/1-20)	
S423	1-554-303-21	SWITCH, TACTILE (PEAK SEARCH)	
S424	1-554-303-21	SWITCH, TACTILE (A. SPACE/A. CUE)	
S425	1-554-303-21	SWITCH, TACTILE (MUSIC SCAN)	
S426	1-554-303-21	SWITCH, TACTILE (TIME)	
S427	1-554-303-21	SWITCH, TACTILE (REPEAT)	
S428	1-554-303-21	SWITCH, TACTILE (FADER)	
S429	1-554-303-21	SWITCH, TACTILE (EDIT/TIME FADE)	
S430	1-554-303-21	SWITCH, TACTILE (<<)	
S431	1-554-303-21	SWITCH, TACTILE (>>)	
S432	1-554-303-21	SWITCH, TACTILE (▶)	
S433	1-554-303-21	SWITCH, TACTILE (■)	
S434	1-554-303-21	SWITCH, TACTILE (■)	
S435	1-554-303-21	SWITCH, TACTILE (<<)	
S436	1-554-303-21	SWITCH, TACTILE (>>)	
S437	1-554-303-21	SWITCH, TACTILE (CHECK)	
S438	1-554-303-21	SWITCH, TACTILE (CLEAR)	

*	1-643-868-11	HP BOARD	

		< CAPACITOR >	
C511	1-162-290-31	CERAMIC 470PF 10% 50V	
C512	1-162-290-31	CERAMIC 470PF 10% 50V	
C513	1-164-159-11	CERAMIC 0.1uF 50V	
		< JACK >	
J511	1-568-519-41	JACK, LARGE TYPE (PHONES)	
		< RESISTOR >	
R511	1-249-402-11	CARBON 56 5% 1/4W	
R512	1-249-402-11	CARBON 56 5% 1/4W	

Ref. No.	Part No.	Description	Remark
*	1-632-202-11	LOADING BOARD	

		< CONNECTOR >	
* CN301	1-564-707-11	PIN, CONNECTOR (SMALL TYPE) 5P	
		< SWITCH >	
S271	1-572-086-11	SWITCH, LEAF (LOAD OUT)	
S272	1-572-086-11	SWITCH, LEAF (LOAD IN)	

*	A-4649-140-A	MAIN BOARD, COMPLETE (CND, AEP, AUS)	
*	A-4649-253-A	MAIN BOARD, COMPLETE (E)	

*	4-941-237-01	HEAT SINK	
		< CAPACITOR >	
C201	1-124-572-11	ELECT 100uF 20% 63V	
C202	1-126-059-11	ELECT 10uF 20% 50V	
C203	1-124-360-00	ELECT 1000uF 20% 16V	
C204	1-126-937-11	ELECT 4700uF 20% 16V	
C205	1-126-163-11	ELECT 4.7uF 20% 50V	
C206	1-126-059-11	ELECT 10uF 20% 50V	
C207	1-126-059-11	ELECT 10uF 20% 50V	
C208	1-124-997-11	ELECT 470uF 20% 10V	
C209	1-124-997-11	ELECT 470uF 20% 10V	
C211	1-124-997-11	ELECT 470uF 20% 10V	
C212	1-124-997-11	ELECT 470uF 20% 10V	
C213	1-130-487-00	MYLAR 0.022uF 5% 50V	
C214	1-126-023-11	ELECT 100uF 20% 16V	
C220	1-164-159-11	CERAMIC 0.1uF 50V	
C221	1-164-159-11	CERAMIC 0.1uF 50V	
C223	1-164-159-11	CERAMIC 0.1uF 50V	
C224	1-164-159-11	CERAMIC 0.1uF 50V	
C225	1-164-159-11	CERAMIC 0.1uF 50V	
C226	1-164-159-11	CERAMIC 0.1uF 50V	
C227	1-164-159-11	CERAMIC 0.1uF 50V	
C301	1-126-022-11	ELECT 47uF 20% 16V	
C302	1-126-301-11	ELECT 1uF 20% 50V	
C303	1-164-159-11	CERAMIC 0.1uF 50V	
C304	1-164-159-11	CERAMIC 0.1uF 50V	
C305	1-126-022-11	ELECT 47uF 20% 16V	
C306	1-164-159-11	CERAMIC 0.1uF 50V	
C307	1-164-159-11	CERAMIC 0.1uF 50V	
C308	1-164-159-11	CERAMIC 0.1uF 50V	
C309	1-164-159-11	CERAMIC 0.1uF 50V	
C311	1-130-491-00	MYLAR 0.047uF 5% 50V	
C312	1-161-374-11	CERAMIC 0.0015uF 20% 50V	

MAIN

Ref. No.	Part No.	Description	Remark		Ref. No.	Part No.	Description	Remark	
C313	1-161-494-00	CERAMIC	0.022uF	25V	C911	1-126-012-11	ELECT	470uF	20% 16V
C314	1-162-306-11	CERAMIC	0.01uF	20% 16V	C913	1-161-494-00	CERAMIC	0.022uF	25V
C315	1-126-300-11	ELECT	0.47uF	20% 50V	C914	1-161-494-00	CERAMIC	0.022uF	25V
C316	1-161-494-00	CERAMIC	0.022uF	25V	C915	1-126-022-11	ELECT	47uF	20% 16V
C319	1-162-282-31	CERAMIC	100PF	10% 50V	C916	1-126-022-11	ELECT	47uF	20% 16V
C320	1-130-483-00	MYLAR	0.01uF	5% 50V	C917	1-162-219-31	CERAMIC	68PF	5% 50V
C321	1-162-208-31	CERAMIC	24PF	5% 50V	C918	1-162-219-31	CERAMIC	68PF	5% 50V
C322	1-126-022-11	ELECT	47uF	20% 16V	C919	1-124-463-00	ELECT	0.1uF	20% 50V
C323	1-164-159-11	CERAMIC	0.1uF	50V	C920	1-124-463-00	ELECT	0.1uF	20% 50V
C324	1-164-159-11	CERAMIC	0.1uF	50V	C921	1-124-463-00	ELECT	0.1uF	20% 50V
C325	1-162-205-31	CERAMIC	18PF	5% 50V	C922	1-124-463-00	ELECT	0.1uF	20% 50V
C326	1-162-205-31	CERAMIC	18PF	5% 50V	C923	1-124-463-00	ELECT	0.1uF	20% 50V
C327	1-161-494-00	CERAMIC	0.022uF	25V	C924	1-124-463-00	ELECT	0.1uF	20% 50V
C328	1-126-059-11	ELECT	10uF	20% 50V					
C329	1-126-022-11	ELECT	47uF	20% 16V			< CONNECTOR >		
C331	1-161-494-00	CERAMIC	0.022uF	25V	* CN201	1-580-230-11	PIN, CONNECTOR (PC BOARD)	3P	
C332	1-164-159-11	CERAMIC	0.1uF	50V	* CN301	1-568-822-11	SOCKET, CONNECTOR	22P	
C333	1-162-294-31	CERAMIC	0.001uF	10% 50V	* CN302	1-691-958-11	SOCKET, CONNECTOR	35P	
C351	1-126-022-11	ELECT	47uF	20% 16V	* CN381	1-568-832-11	SOCKET, CONNECTOR	13P	
C352	1-164-159-11	CERAMIC	0.1uF	50V			< DIODE >		
C353	1-126-022-11	ELECT	47uF	20% 16V	D201	8-719-200-82	DIODE	11ES2	
C354	1-161-494-00	CERAMIC	0.022uF	25V	D202	8-719-121-24	DIODE	RD9.1ES-L	
C355	1-126-022-11	ELECT	47uF	20% 16V	D203	8-719-200-82	DIODE	11ES2	
C356	1-164-159-11	CERAMIC	0.1uF	50V	D204	8-719-200-82	DIODE	11ES2	
C357	1-130-495-00	MYLAR	0.1uF	5% 50V	D205	8-719-200-82	DIODE	11ES2	
C358	1-130-495-00	MYLAR	0.1uF	5% 50V	D206	8-719-200-82	DIODE	11ES2	
C361	1-162-280-31	CERAMIC	82PF	10% 50V	D208	8-719-109-89	DIODE	RD5.6ES-B2	
C362	1-162-280-31	CERAMIC	82PF	10% 50V	D209	8-719-987-63	DIODE	1N4148M	
C363	1-162-213-31	CERAMIC	39PF	5% 50V	D328	8-719-987-63	DIODE	1N4148M	
C364	1-162-213-31	CERAMIC	39PF	5% 50V	D344	8-719-987-63	DIODE	1N4148M	
C365	1-162-213-31	CERAMIC	39PF	5% 50V			< IC >		
C366	1-162-213-31	CERAMIC	39PF	5% 50V	IC201	8-759-633-42	IC	M5293L	
C367	1-161-494-00	CERAMIC	0.022uF	25V	IC202	8-759-630-21	IC	M5290P-16	
C368	1-161-494-00	CERAMIC	0.022uF	25V	IC203	8-759-945-58	IC	RC4558P	
C371	1-130-479-00	MYLAR	0.0047uF	5% 50V	IC204	8-759-604-86	IC	M5F7807L	
C372	1-130-479-00	MYLAR	0.0047uF	5% 50V	IC301	8-752-337-26	IC	CXD2500AQ	
C373	1-130-472-00	MYLAR	0.0012uF	5% 50V	IC302	8-752-342-65	IC	CXD2560M	
C374	1-130-472-00	MYLAR	0.0012uF	5% 50V	IC303	8-752-349-02	IC	CXD2561AM-1	
C377	1-126-022-11	ELECT	47uF	20% 16V	IC306	8-759-503-91	IC	TL082ACP	
C378	1-126-022-11	ELECT	47uF	20% 16V	IC307	8-759-900-72	IC	NE5532P	
C379	1-130-473-00	MYLAR	0.0015uF	5% 50V	IC391	8-749-921-20	IC	T-1550	
C380	1-130-473-00	MYLAR	0.0015uF	5% 50V	IC901	8-759-232-07	IC	TC74HC04AP	
C391	1-162-286-31	CERAMIC	220PF	10% 50V	IC902	8-752-341-99	IC	CXD2701Q	
C393	1-164-159-11	CERAMIC	0.1uF	50V	IC903	8-759-508-41	IC	MS51464-10NC	
C396	1-164-159-11	CERAMIC	0.1uF	50V	IC904	8-759-900-72	IC	NE5532P	
C397	1-164-159-11	CERAMIC	0.1uF	50V					
C901	1-164-159-11	CERAMIC	0.1uF	50V					
C905	1-164-159-11	CERAMIC	0.1uF	50V					
C910	1-126-012-11	ELECT	470uF	20% 16V					

Ref. No.	Part No.	Description	Remark	Ref. No.	Part No.	Description	Remark
		< JACK >					
* J381	1-569-443-11	JACK, PIN 4P (LINE OUT FIXED/VARIABLE)		R214	1-249-417-11	CARBON	1K 5% 1/4W
		< COIL >		R301	1-249-417-11	CARBON	1K 5% 1/4W
L305	1-408-403-00	INDUCTOR 3. 3uH		R302	1-249-417-11	CARBON	1K 5% 1/4W
L306	1-408-403-00	INDUCTOR 3. 3uH		R303	1-249-421-11	CARBON	2. 2K 5% 1/4W
L321	1-408-403-00	INDUCTOR 3. 3uH		R304	1-249-417-11	CARBON	1K 5% 1/4W
		< TRANSISTOR >		R305	1-249-411-11	CARBON	330 5% 1/4W
Q201	8-729-119-76	TRANSISTOR 2SA1175-HFE		R306	1-249-413-11	CARBON	470 5% 1/4W
Q202	8-729-140-96	TRANSISTOR 2SD774-34		R309	1-249-405-11	CARBON	100 5% 1/4W
Q203	8-729-141-83	TRANSISTOR 2SB1094-LK		R311	1-249-423-11	CARBON	3. 3K 5% 1/4W
Q204	8-729-900-65	TRANSISTOR DTA144ES		R312	1-249-429-11	CARBON	10K 5% 1/4W
Q205	8-729-900-89	TRANSISTOR DTC144ES		R313	1-249-423-11	CARBON	3. 3K 5% 1/4W
Q206	8-729-900-89	TRANSISTOR DTC144ES		R314	1-249-429-11	CARBON	10K 5% 1/4W
Q209	8-729-281-52	TRANSISTOR 2SC1815-Y		R318	1-249-441-11	CARBON	100K 5% 1/4W
Q341	8-729-900-65	TRANSISTOR DTA144ES		R319	1-247-903-00	CARBON	1M 5% 1/4W
Q342	8-729-900-65	TRANSISTOR DTA144ES		R320	1-249-417-11	CARBON	1K 5% 1/4W
Q343	8-729-900-65	TRANSISTOR DTA144ES		R321	1-249-417-11	CARBON	1K 5% 1/4W
Q344	8-729-900-89	TRANSISTOR DTC144ES		R322	1-249-417-11	CARBON	1K 5% 1/4W
Q371	8-729-141-30	TRANSISTOR 2SC3623A-LK		R323	1-249-417-11	CARBON	1K 5% 1/4W
Q372	8-729-141-30	TRANSISTOR 2SC3623A-LK		R324	1-249-417-11	CARBON	1K 5% 1/4W
Q373	8-729-141-30	TRANSISTOR 2SC3623A-LK		R325	1-249-417-11	CARBON	1K 5% 1/4W
Q374	8-729-141-30	TRANSISTOR 2SC3623A-LK		R326	1-249-417-11	CARBON	1K 5% 1/4W
Q375	8-729-231-55	TRANSISTOR 2SC2878-AB		R327	1-247-903-00	CARBON	1M 5% 1/4W
Q376	8-729-231-55	TRANSISTOR 2SC2878-AB		R328	1-249-429-11	CARBON	10K 5% 1/4W
Q393	8-729-119-76	TRANSISTOR 2SA1175-HFE		R331	1-249-429-11	CARBON	10K 5% 1/4W
Q912	8-729-900-63	TRANSISTOR DTA124ES		R332	1-249-429-11	CARBON	10K 5% 1/4W
Q913	8-729-900-63	TRANSISTOR DTA124ES		R333	1-249-429-11	CARBON	10K 5% 1/4W
Q914	8-729-900-63	TRANSISTOR DTA124ES		R334	1-249-429-11	CARBON	10K 5% 1/4W
Q919	8-729-231-55	TRANSISTOR 2SC2878-AB		R343	1-249-441-11	CARBON	100K 5% 1/4W
Q920	8-729-231-55	TRANSISTOR 2SC2878-AB		R344	1-249-441-11	CARBON	100K 5% 1/4W
Q921	8-729-231-55	TRANSISTOR 2SC2878-AB		R345	1-249-425-11	CARBON	4. 7K 5% 1/4W
Q922	8-729-231-55	TRANSISTOR 2SC2878-AB		R346	1-249-425-11	CARBON	4. 7K 5% 1/4W
Q923	8-729-231-55	TRANSISTOR 2SC2878-AB		R347	1-249-441-11	CARBON	100K 5% 1/4W
Q924	8-729-231-55	TRANSISTOR 2SC2878-AB		R348	1-249-429-11	CARBON	10K 5% 1/4W
		< RESISTOR >		R351	1-249-436-11	CARBON	39K 5% 1/4W
R201	1-249-435-11	CARBON	33K 5% 1/4W	R352	1-249-436-11	CARBON	39K 5% 1/4W
R202	1-249-438-11	CARBON	56K 5% 1/4W	R353	1-249-436-11	CARBON	39K 5% 1/4W
R203	1-249-429-11	CARBON	10K 5% 1/4W	R354	1-249-436-11	CARBON	39K 5% 1/4W
R204	1-249-425-11	CARBON	4. 7K 5% 1/4W	R355	1-249-436-11	CARBON	39K 5% 1/4W
R205	1-249-425-11	CARBON	4. 7K 5% 1/4W	R356	1-249-436-11	CARBON	39K 5% 1/4W
R208	1-249-423-11	CARBON	3. 3K 5% 1/4W	R357	1-249-436-11	CARBON	39K 5% 1/4W
R209	1-249-413-11	CARBON	470 5% 1/4W	R358	1-249-436-11	CARBON	39K 5% 1/4W
R210	1-249-429-11	CARBON	10K 5% 1/4W	R361	1-249-431-11	CARBON	15K 5% 1/4W
R211	1-249-410-11	CARBON	270 5% 1/4W	R362	1-249-431-11	CARBON	15K 5% 1/4W
R213	1-249-417-11	CARBON	1K 5% 1/4W	R363	1-249-431-11	CARBON	15K 5% 1/4W
				R364	1-249-431-11	CARBON	15K 5% 1/4W
				R365	1-249-438-11	CARBON	56K 5% 1/4W
				R366	1-249-438-11	CARBON	56K 5% 1/4W
				R367	1-249-438-11	CARBON	56K 5% 1/4W
				R368	1-249-438-11	CARBON	56K 5% 1/4W

MAIN REMOTE CONTROL VOL

Ref. No.	Part No.	Description	Remark
R369	1-249-419-11	CARBON	1.5K 5% 1/4W
R370	1-249-419-11	CARBON	1.5K 5% 1/4W
R371	1-249-419-11	CARBON	1.5K 5% 1/4W
R372	1-249-419-11	CARBON	1.5K 5% 1/4W
R373	1-247-887-00	CARBON	220K 5% 1/4W
R374	1-247-887-00	CARBON	220K 5% 1/4W
R375	1-249-409-11	CARBON	220 5% 1/4W
R376	1-249-409-11	CARBON	220 5% 1/4W
R377	1-249-409-11	CARBON	220 5% 1/4W
R378	1-249-409-11	CARBON	220 5% 1/4W
R379	1-249-425-11	CARBON	4.7K 5% 1/4W
R380	1-249-425-11	CARBON	4.7K 5% 1/4W
R381	1-249-425-11	CARBON	4.7K 5% 1/4W
R382	1-249-425-11	CARBON	4.7K 5% 1/4W
R383	1-249-413-11	CARBON	470 5% 1/4W
R384	1-249-413-11	CARBON	470 5% 1/4W
R385	1-249-393-11	CARBON	10 5% 1/4W
R386	1-249-393-11	CARBON	10 5% 1/4W
R389	1-249-413-11	CARBON	470 5% 1/4W
R390	1-249-413-11	CARBON	470 5% 1/4W
R392	1-249-405-11	CARBON	100 5% 1/4W
R393	1-249-406-11	CARBON	120 5% 1/4W
R394	1-249-435-11	CARBON	33K 5% 1/4W
R901	1-249-417-11	CARBON	1K 5% 1/4W
R902	1-249-419-11	CARBON	1.5K 5% 1/4W
R903	1-249-417-11	CARBON	1K 5% 1/4W
R904	1-249-417-11	CARBON	1K 5% 1/4W
R905	1-249-417-11	CARBON	1K 5% 1/4W
R906	1-247-887-00	CARBON	220K 5% 1/4W
R907	1-249-417-11	CARBON	1K 5% 1/4W
R908	1-249-417-11	CARBON	1K 5% 1/4W
R909	1-249-417-11	CARBON	1K 5% 1/4W
R910	1-249-405-11	CARBON	100 5% 1/4W
R911	1-249-405-11	CARBON	100 5% 1/4W
R912	1-249-441-11	CARBON	100K 5% 1/4W
R913	1-249-441-11	CARBON	100K 5% 1/4W
R914	1-249-441-11	CARBON	100K 5% 1/4W
R915	1-249-419-11	CARBON	1.5K 5% 1/4W
R916	1-249-419-11	CARBON	1.5K 5% 1/4W
R917	1-249-441-11	CARBON	100K 5% 1/4W
R918	1-249-441-11	CARBON	100K 5% 1/4W
R919	1-249-425-11	CARBON	4.7K 5% 1/4W
R920	1-249-425-11	CARBON	4.7K 5% 1/4W
R921	1-249-421-11	CARBON	2.2K 5% 1/4W
R922	1-249-421-11	CARBON	2.2K 5% 1/4W
R923	1-249-422-11	CARBON	2.7K 5% 1/4W
R924	1-249-422-11	CARBON	2.7K 5% 1/4W
R925	1-249-425-11	CARBON	4.7K 5% 1/4W
R926	1-249-425-11	CARBON	4.7K 5% 1/4W

Ref. No.	Part No.	Description	Remark
R927	1-249-419-11	CARBON	1.5K 5% 1/4W
R928	1-249-419-11	CARBON	1.5K 5% 1/4W
R929	1-247-828-11	CARBON	750 5% 1/4W
R930	1-247-828-11	CARBON	750 5% 1/4W
R931	1-249-425-11	CARBON	4.7K 5% 1/4W
R932	1-249-425-11	CARBON	4.7K 5% 1/4W
R933	1-249-417-11	CARBON	1K 5% 1/4W
R934	1-249-417-11	CARBON	1K 5% 1/4W
R935	1-249-410-11	CARBON	270 5% 1/4W
R936	1-249-410-11	CARBON	270 5% 1/4W
R941	1-249-417-11	CARBON	1K 5% 1/4W
R942	1-249-417-11	CARBON	1K 5% 1/4W
R943	1-249-417-11	CARBON	1K 5% 1/4W
< SWITCH >			
△S201	1-571-722-11	SWITCH, VOLTAGE SELECTION (E) (VOLTAGE SELECTOR)	
< CRYSTAL >			
X327	1-579-314-11	VIBRATOR, CRYSTAL (22.5MHz)	

*	1-643-864-11	REMOTE CONTROL VOL BOARD	

*	4-922-980-01	HOLDER (LED)	
< CAPACITOR >			
C451	1-124-994-11	ELECT	100uF 20% 10V
C452	1-124-994-11	ELECT	100uF 20% 10V
C471	1-124-994-11	ELECT	100uF 20% 10V
C472	1-124-277-11	ELECT	4.7uF 20% 35V
< CONNECTOR >			
* CN451	1-568-832-11	SOCKET, CONNECTOR 13P	
* CN472	1-564-719-11	PIN, CONNECTOR (SMALL TYPE) 3P	
< DIODE >			
D471	8-719-970-49	DIODE	BR4361F
< IC >			
IC451	8-759-981-89	IC	RC4556S
IC471	8-759-962-08	IC	BA6208
< RESISTOR >			
R451	1-249-435-11	CARBON	33K 5% 1/4W
R452	1-249-435-11	CARBON	33K 5% 1/4W
R453	1-249-432-11	CARBON	18K 5% 1/4W
R454	1-249-432-11	CARBON	18K 5% 1/4W

The components identified by mark △ or dotted line with mark △ are critical for safety. Replace only with part number specified.

Les composants identifiés par une marque △ sont critiques pour la sécurité. Ne les remplacer que par une pièce portant le numéro spécifié.

REMOTE CONTROL VOL

Ref. No.	Part No.	Description	Remark
R455	1-249-422-11	CARBON	2.7K 5% 1/4W
R456	1-249-422-11	CARBON	2.7K 5% 1/4W
R457	1-249-429-11	CARBON	10K 5% 1/4W
R458	1-249-429-11	CARBON	10K 5% 1/4W
R461	1-249-399-11	CARBON	33 5% 1/4W
R462	1-249-399-11	CARBON	33 5% 1/4W
R471	1-249-411-11	CARBON	.330 5% 1/4W
R472	1-249-417-11	CARBON	1K 5% 1/4W
R473	1-249-417-11	CARBON	1K 5% 1/4W

< VARIABLE RESISTOR >

RV451 1-238-974-11 RES, VAR, CARBON 10K/10K
(LINE OUT PHONE LEVEL)

MISCELLANEOUS

14 1-690-923-11 WIRE (FLAT TYPE) (35 CORE)
27 1-690-392-11 WIRE, FLAT TYPE (13 CORE)
53 1-575-002-11 WIRE, FLAT TYPE (22 CORE)

△58 1-558-943-41 CORD, POWER (E)
△58 1-574-358-31 CORD, POWER (WITH CONNECTOR) (AUS)
△58 1-575-651-21 CORD, POWER (AEP)
△58 1-590-836-11 CORD, POWER (CND)

△62 1-569-007-11 ADAPTER, CONVERSION 2P (E)
* 311 1-452-538-11 MAGNET
△355 8-848-144-11 PICK-UP, OPTICAL KSS-240A
358 1-575-001-11 WIRE, FLAT TYPE (12 CORE)

M102 X-4917-504-1 MOTOR ASSY (SLED)
M201 1-541-632-11 MOTOR, DC (LOADING)

△PT1 1-449-921-11 TRANSFORMER, POWER (CND)
△PT1 1-449-922-11 TRANSFORMER, POWER (AEP, AUS)
△PT1 1-449-923-11 TRANSFORMER, POWER (E)

ACCESSORIES & PACKING MATERIALS

1-465-875-11 REMOTE COMMANDER (RM-D897)
1-558-271-11 CORD, CONNECTION
3-707-584-01 COVER, BATTERY

3-754-718-11 MANUAL, INSTRUCTION (ENGLISH, FRENCH,
SPANISH, PORTUGUESE) (CND, AEP, E, AUS)

3-754-718-41 MANUAL, INSTRUCTION
(GERMAN, ITALIAN, DUTCH, SWEDISH) (AEP)

* 4-941-548-01 LABEL, CLASS 1 (AEP, E, AUS)
* 4-941-925-01 CUSHION
* 4-948-308-21 INDIVIDUAL CARTON

Ref. No.	Part No.	Description	Remark
HARDWARE LIST			

#1	7-621-775-10	SCREW +B 2.6X4	
#2	7-621-255-15	SCREW +P 2X3	
#3	7-682-547-09	SCREW +B 3X6	
#4	7-682-548-04	SCREW +BVTT 3X8 (S)	
#5	7-682-548-09	SCREW +BVTT 3X8 (S)	
#6	7-685-646-79	SCREW +BVTP 3X8 TYPE2 N-S	
#7	7-685-647-79	SCREW +BVTP 3X10 TYPE2 N-S	

The components identified by mark △ or dotted line with mark △ are critical for safety. Replace only with part number specified.

Les composants identifiés par une marque △ sont critiques pour la sécurité. Ne les remplacer que par une pièce portant le numéro spécifié.

