

CDP-C211/C215/C315

SERVICE MANUAL

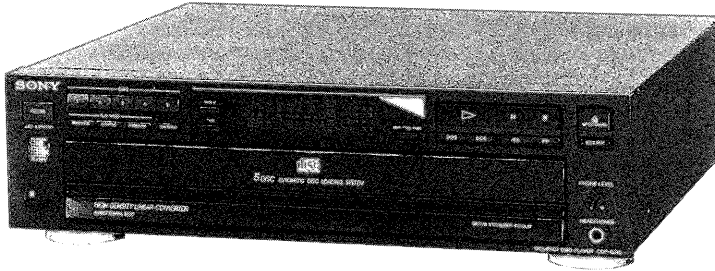

US Model
Canadian Model
AEP Model
UK Model
E Model
Australian Model
CDP-C315
US Model
Canadian Model
CDP-C215
US Model
CDP-C211

Model Name Using Similar Mechanism	CDP-C312M
CD Mechanism Type	CDM16E2-5BD3
Optical Pick-Up Block Type	BU-5BD3

SPECIFICATIONS

System Compact disc digital audio system
Laser Semiconductor laser ($\lambda=780$ nm)
 Emission duration: continuous
Laser output Max. 44.6 μ W*
 * This output is the value measured at a distance of about 200 mm from the objective lens surface on the Optical Pick-up Block.
Frequency response 2 Hz — 20 kHz (± 0.5 dB)
Signal to noise ratio More than 100 dB
Dynamic range More than 98 dB
Harmonic distortion Less than 0.005% (1 kHz)
Channel separation More than 100 dB (1 kHz)
Wow and flutter Below measurable limit
Outputs LINE OUT (phono jacks)
 Output level 2 V (at 50 kilohms)
 Load impedance over 10 kilohms
 PHONES (stereo phone jack) (CDP-C315/C215 only)
 Output level 0 — 10 mW (variable) (at 32 ohms)

General

Power requirements Model for USA and Canada
 120 V AC, 60Hz
 Model for Australia (CDP-C315 only)
 240 V AC, 50/60 Hz

Power consumption 12 W
Dimensions CDP-C315/C215/C211
 Approx. 430 × 125 × 385 mm
 (w/h/d) (17 × 5 × 15¼ inches)
 including projecting parts and controls
Weight CDP-C315/C215/C211
 Approx. 6 kg (13 lbs 4 oz), net

Remote commander RM-D315

Remote control system Infrared control
Power requirements 3-V DC with two batteries size AA (IEC designation R6)

Supplied accessories

Audio signal connecting cord
 (phono plug × 2 ↔ phono plug × 2) (1)
 Remote commander (1) (CDP-C315 only)
 R6 (size AA) batteries (2) (CDP-C315 only)
 Operating Manual (1)

Design and specifications subject to change without notice.

COMPACT DISK PLAYER
SONY®

Note on the Transit Key

The transit key on the bottom exterior of the unit protects the optical system against shock during transportation. Before operating the CD player, be sure to remove the key by following the instructions on the label, and store it in a safe place.

When transporting the unit, replace the key in its original hole and lock it in place.

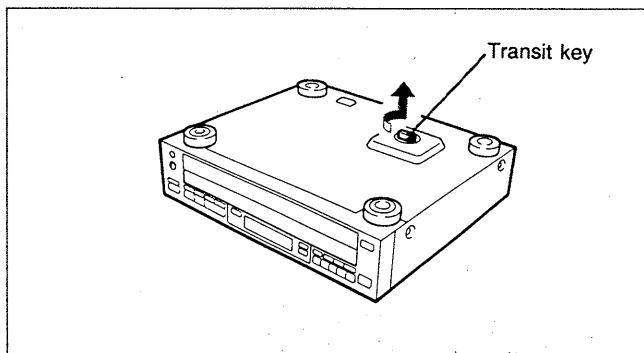





TABLE OF CONTENTS

<u>Section</u>	<u>Title</u>	<u>Page</u>	<u>Section</u>	<u>Title</u>	<u>Page</u>
1. GENERAL			5. EXPLODED VIEWS		
1-1. Location of Controls		5	5-1. Front Panel and Case Assemblies		21
2. DISASSEMBLY			5-2. Disc Tray Assembly		22
2-1. Removal of Front Panel and Case Assemblies		6	5-3. Chassis Assembly		23
2-2. Removal of Disc Tray Assembly		6	5-4. Optical Pick-up Block Assembly (BU-5BD3)		24
2-3. Removal of Optical Pick-up Block Assembly		6	6. ELECTRICAL PARTS LIST		25
3. ELECTRICAL BLOCK CHECKING		7			
4. DIAGRAMS					
4-1. Circuit Boards Location		9			
4-2. Semiconductor Lead Layouts		9			
4-3. IC Block Diagrams		10			
4-4. Printed Wiring Boards		12			
4-5. Schematic Diagram		17			

SAFETY-RELATED COMPONENT WARNING!!

COMPONENTS IDENTIFIED BY MARK  OR DOTTED LINE WITH MARK  ON THE SCHEMATIC DIAGRAMS AND IN THE PARTS LIST ARE CRITICAL TO SAFE OPERATION. REPLACE THESE COMPONENTS WITH SONY PARTS WHOSE PART NUMBERS APPEAR AS SHOWN IN THIS MANUAL OR IN SUPPLEMENTS PUBLISHED BY SONY.

ATTENTION AU COMPOSANT AYANT RAPPORT À LA SÉCURITÉ!

LES COMPOSANTS IDENTIFIÉS PAR UNE MARQUE  SUR LES DIAGRAMMES SCHÉMATIQUES ET LA LISTE DES PIÈCES SONT CRITIQUES POUR LA SÉCURITÉ DE FONCTIONNEMENT. NE REMPLACER CES COMPOSANTS QUE PAR DES PIÈCES SONY DONT LES NUMÉROS SONT DONNÉS DANS CE MANUEL OU DANS LES SUPPLÉMENTS PUBLIÉS PAR SONY.

MODEL IDENTIFICATION

—Model Number Label—

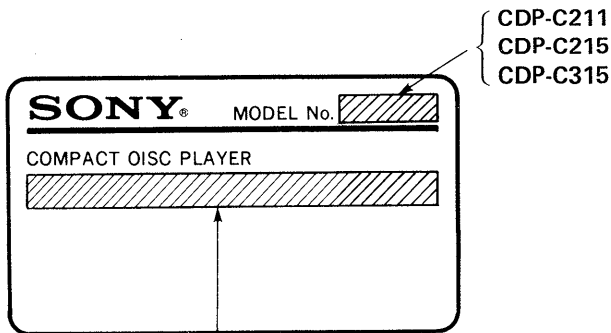

US, Canadian model : AC : 120V 60Hz 11W
 AEP model : AC : 220-230V~50/60Hz
 UK, Australian model : AC : 240V~50/60Hz
 E model : AC : 110-120V, 220-240V~50/60Hz

NOTES ON HANDLING THE OPTICAL PICK-UP BLOCK OR BASE UNIT

The laser diode in the optical pick-up block may suffer electrostatic breakdown because of the potential difference generated by the charged electrostatic load, etc. on clothing and the human body.

During repair, pay attention to electrostatic breakdown and also use the procedure in the printed matter which is included in the repair parts.

The flexible board is easily damaged and should be handled with care.

NOTES ON LASER DIODE EMISSION CHECK

The laser beam on this model is concentrated so as to be focused on the disc reflective surface by the objective lens in the optical pick-up block. Therefore, when checking the laser diode emission, observe from more than 30cm away from the objective lens.

SAFETY CHECK-OUT

After correcting the original service problem, perform the following safety check before releasing the set to the customer:

Check the antenna terminals, metal trim, "metallized" knobs, screws, and all other exposed metal parts for AC leakage. Check leakage as described below.

LEAKAGE TEST

The AC leakage from any exposed metal part to earth ground and from all exposed metal parts to any exposed metal part having a return to chassis, must not exceed 0.5 mA (500 microamperes). Leakage current can be measured by any one of three methods.

1. A commercial leakage tester, such as the Simpson 229 or RCA WT-540A. Follow the manufacturers' instructions to use these instruments.
2. A battery-operated AC milliammeter. The Data Precision 245 digital multimeter is suitable for this job.
3. Measuring the voltage drop across a resistor by means of a VOM or battery-operated AC voltmeter. The "limit" indication is 0.75 V, so analog meters must have an accurate low-voltage scale. The Simpson 250 and Sanwa SH-63Trd are examples of a passive VOM that is suitable. Nearly all battery operated digital multimeters that have a 2V AC range are suitable. (See Fig. A)

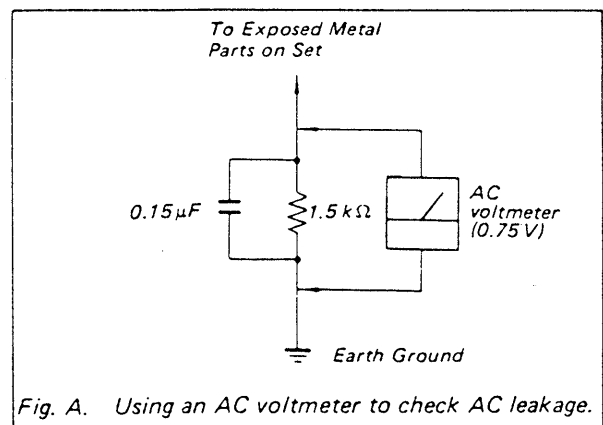

Fig. A. Using an AC voltmeter to check AC leakage.

PROTECTION OF EYES FROM LASER BEAM DURING SERVICING

This set employs a laser. Therefore, be sure to follow carefully the instructions below when servicing.

CAUTION

Use of controls or adjustments or performance of procedures other than those specified herein may result in hazardous radiation exposure.

1. Laser Diode Properties

- Material: GaAlAs
- Wavelength: 780 nm
- Emission Duration: continuous
- Laser Output Power: less than 44.6 μW *

* This output is the value measured at a distance of 200 mm from the objective lens surface on the Optical Pick-up Block.

2. During service, do not take the Optical Pick-up Block apart, and do not adjust the APC circuit. If there is a breakdown in the APC circuit (including laser diode), replace the entire Optical Pick-up Block (including APC board).

BESKYTTELSE AF ØJNE MOD LASERSTRÅLING UNDER SERVICE

I dette apparat anvendes laserlys. Derfor skal nedenstående instruktioner nøje følges under service.

Følg iøvrigt instruktionerne i servicemanualen.

ADVARSEL!!

Under service må øjnene ikke komme nær objektiv-linsen på den optiske pick-up enhed. I tilfælde af at det er nødvendigt at kontrollere udsendelsen af laserlys, skal det ske i en afstand af mere end 25 cm fra den optiske pick-up.

1. Laser-didoe data

- Materiale: GaAlAs
- Bølgelængde: 780 nm
- Udstråling: Kontinuerlig
- Laseroutput: Max. 0,4 mW*

* Målt i 1,6 mm afstand fra overfladen af objektiv-linsen på den optiske pick-up enhed.

- Klassifikation: Klasse IIIb.

2. Adskil aldrig den optiske pick-up enhed under service, og juster ikke APC kredsløbet (Automatic Power Control). Hvis APC kredsløbet (incl. laserdioden) bryder ned, skal hele den optiske pick-up enhed (incl. APC printkortet) udskiftes.

LASER ADVARSEL MÆRKNING

Følgende mærkning findes indvendig i apparatet:

1. Advarsel Mærkning

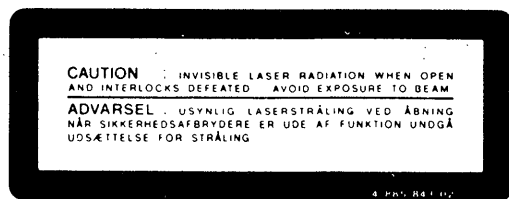

VAROITUS: Laite sisältää, laserdiodin, joka lähettää (näkyvätöntä) silmille vaarallista lasersäteilyä.

SECTION 1 GENERAL

1-1. LOCATION OF CONTROLS

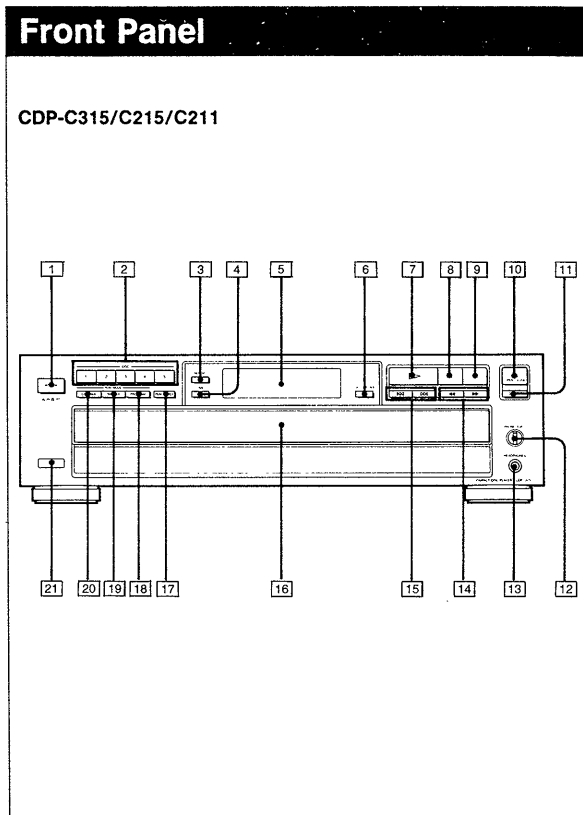

- 1 POWER switch
- 2 Disc 1-5 buttons
- 3 REPEAT button
- 4 TIME button
- 5 Display window
- 6 EDIT/TIME FADE button
- 7 ► (play) button
- 8 || (pause) button
- 9 ■ (stop) button
- 10 ▲ OPEN/CLOSE button
- 11 DISC SKIP button
- 12 (Headphones) PHONE LEVEL control
(CDP-C211 is not provided.)
- 13 HEADPHONES jack (CDP-C211 is not provided.)
- 14 ◀◀/▶▶ (manual search) buttons
- 15 ◀◀▶▶ (AMS*) buttons
- 16 Disc tray
- 17 PEAK SEARCH button
- 18 PROGRAM button
- 19 SHUFFLE button
- 20 CONTINUE button
- 21 Remote sensor

* AMS is the abbreviation of Automatic Music Sensor.

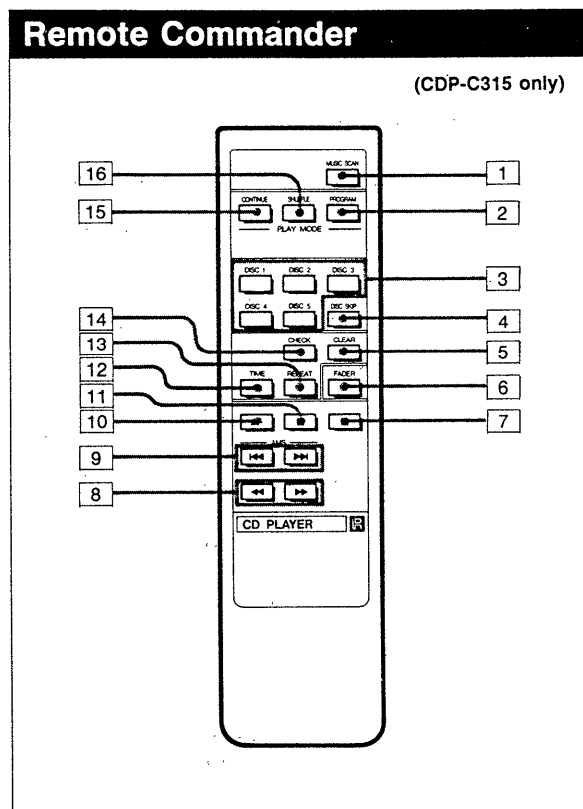

- 1 MUSIC SCAN button
- 2 PROGRAM button
- 3 DISC 1-5 buttons
- 4 DISC SKIP button
- 5 CLEAR (program clear) button
- 6 FADER button
- 7 ■ (stop) button
- 8 ◀◀/▶▶ (manual search) buttons
- 9 ◀◀▶▶ (AMS) buttons
- 10 ► (play) button
- 11 || (pause) button
- 12 TIME button
- 13 REPEAT button
- 14 CHECK (program check) button
- 15 CONTINUE button
- 16 SHUFFLE button

SECTION 2 DISASSEMBLY

2-1. REMOVAL OF FRONT PANEL AND CASE ASSEMBLIES

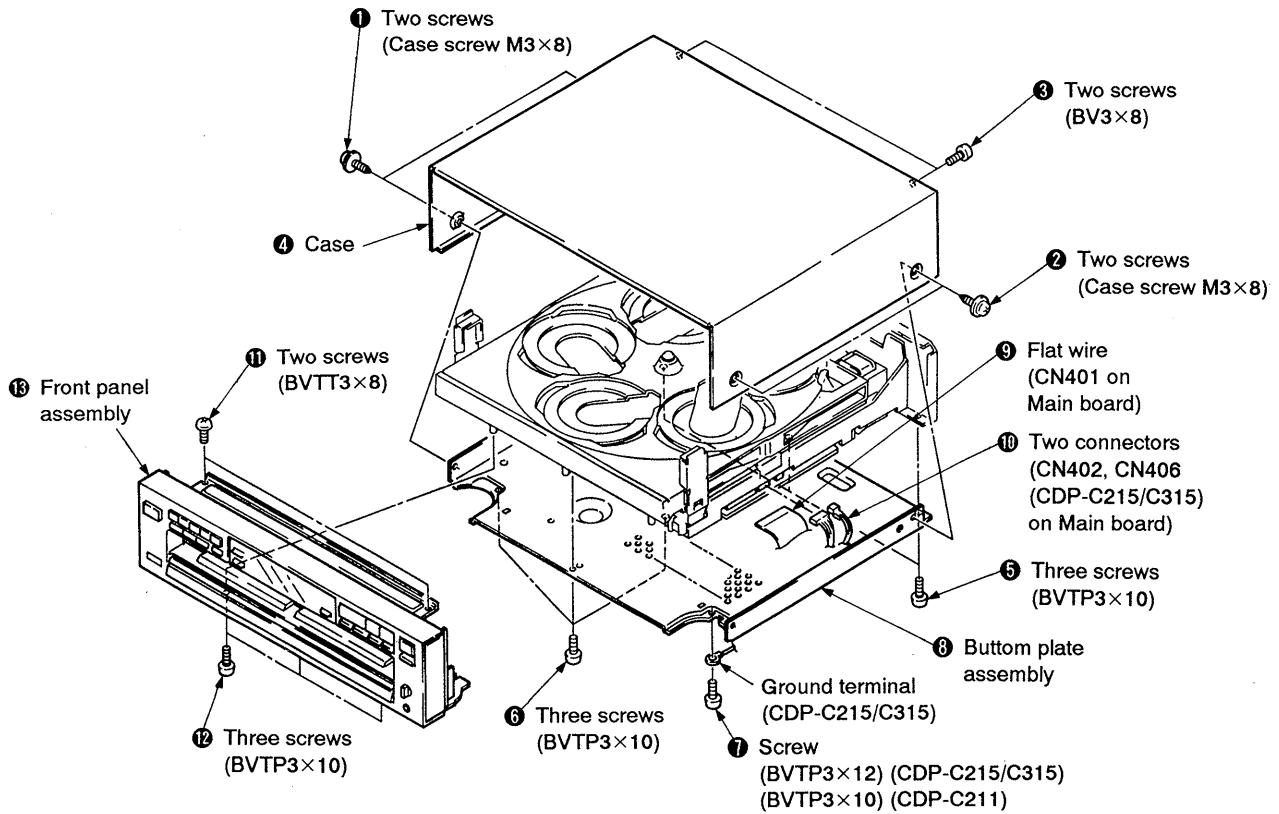

2-2. REMOVAL OF DISC TRAY ASSEMBLY

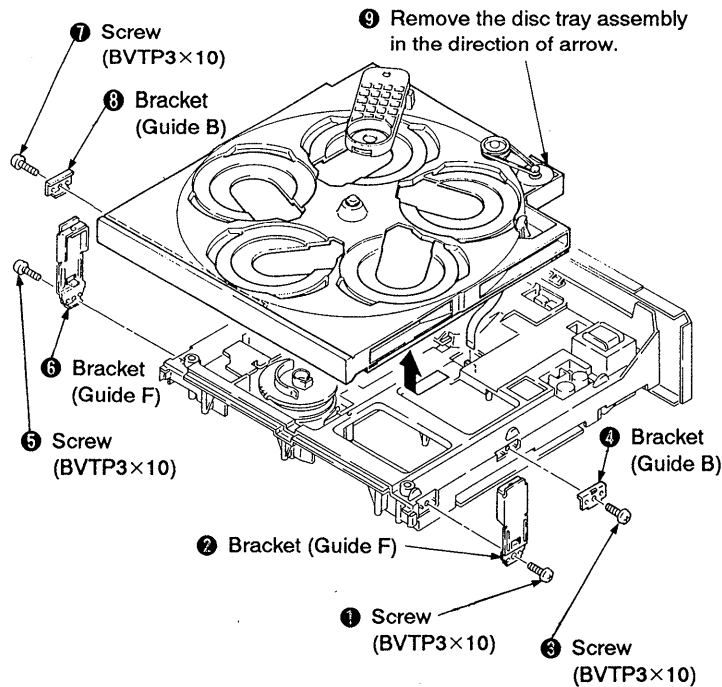

2-3. REMOVAL OF OPTICAL PICK-UP BLOCK ASSEMBLY

1) Replace the set up side down.

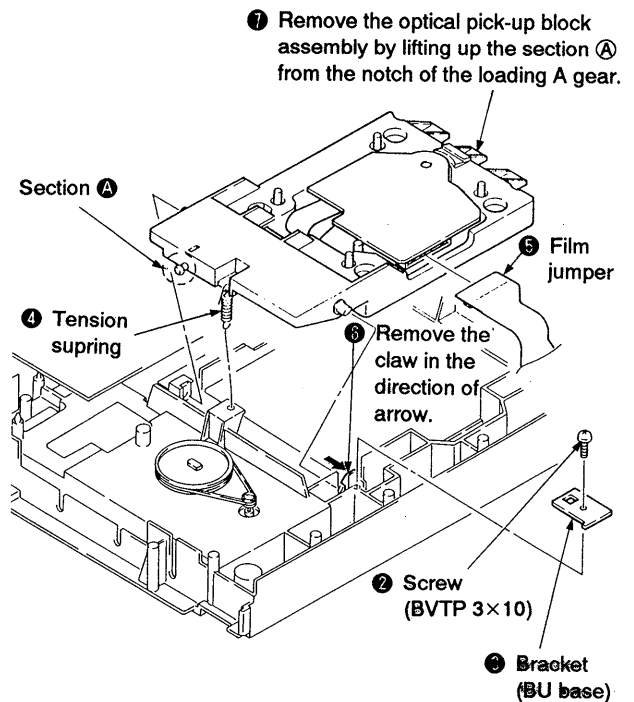

SECTION 3 ELECTRICAL BLOCK CHECKING

Note :

1. CD Block basically constructed to operate without adjustment. Therefore, check each item in order given.
2. Use YEDS-18 disc (3-702-101-01) unless otherwise indicated.
3. Use the oscilloscope with more than $10M\Omega$ impedance.
4. Clean an object lens by an applicator with neutral detergent when the signal level is low than specified value with the following checks.

S Curve Check

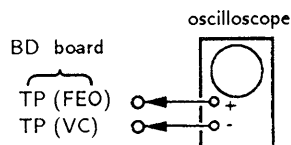

Procedure :

1. Connect oscilloscope to test point TP (FEO) on BD board.
2. Connect between test point TP (FES) and TP (VC) by lead wire.
3. Turned Power switch on and actuate the focus serch. (actuate the focus serch when disc table is moving in and out.)
4. Check the oscilloscope waveform (S curve) is symmetrical between A and B. And confirm peak to peak level within $3 \pm 1V_{p-p}$.

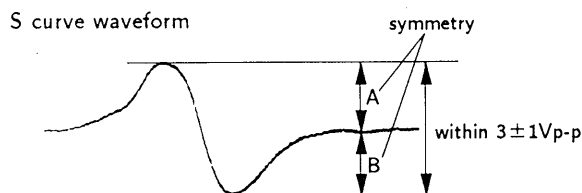

5. After check, remove the lead wire connected in step 2.

Note : • Try to mesure several times to make sure that the ratio of A : B or B : A is more than 10 : 7.

- Take sweep time as long as possible and light up the brightness to obtain best waveform.

RF Level Check

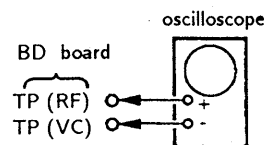

Procedure :

1. Connect oscilloscope to test point TP (RF) on BD board.
2. Turn Power switch on.
3. Put disc (YEDS-18) in and playback.
4. Confirm that oscilloscope waveform is clear and check RF signal level is correct or not.

Note :

Clear RF signal waveform means that the shape "◇" can be clearly distinguished at the center of the waveform.

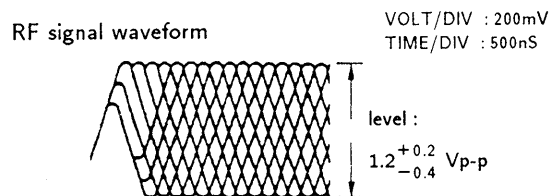

E-F Balance Check

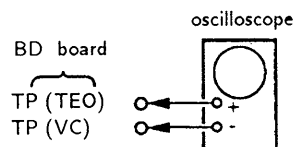

Procedure :

1. Connect test point TP (ADJ) to ground and TP (TES) to TP (VC) with lead wire.
2. Connect oscilloscope to test point TP (TEO) on BD board.
3. Turn Power switch on.
4. Put disc (YEDS-18) in and playback.
5. Confirm that the osilloscope waveform is symmetrical on the top and bottom in relation to 0V, and check this level.

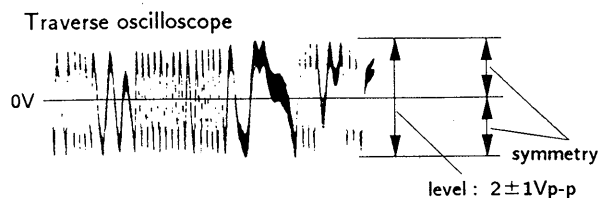

6. Remove the lead wire connected in step 1.

RF PLL Free-run Frequency Check

Procedure :

1. Connect frequency counter to test point (PCK) with lead wire.

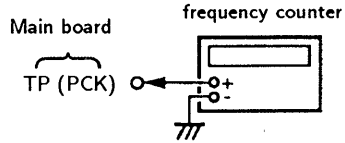

2. Turn Power switch on.
3. Confirm that reading on frequency counter is
4. 3218MHz.

Focus/Tracking Gain

This gain has a margin, so even if it is slightly off. There is no problem.

Therefore, do not perform, this adjustment.

Please note that it should be fixed to mechanical center position when you moved and do not know original position.

Adjustment Locations : [BD board]

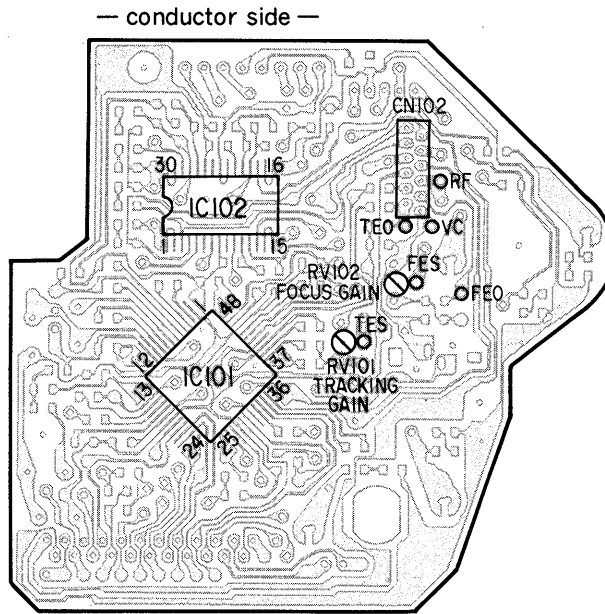

[Main board]

— component side —

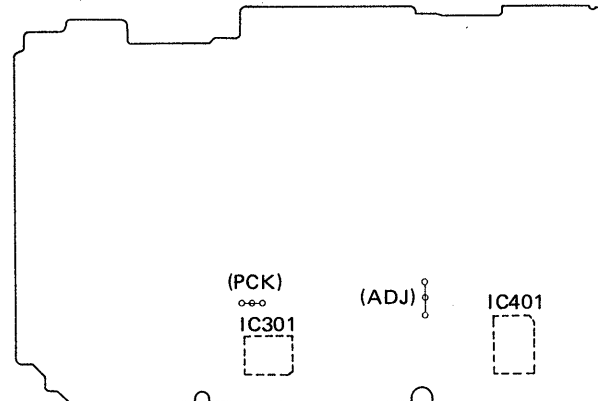

SECTION 4 DIAGRAMS

4-1. CIRCUIT BOARDS LOCATION

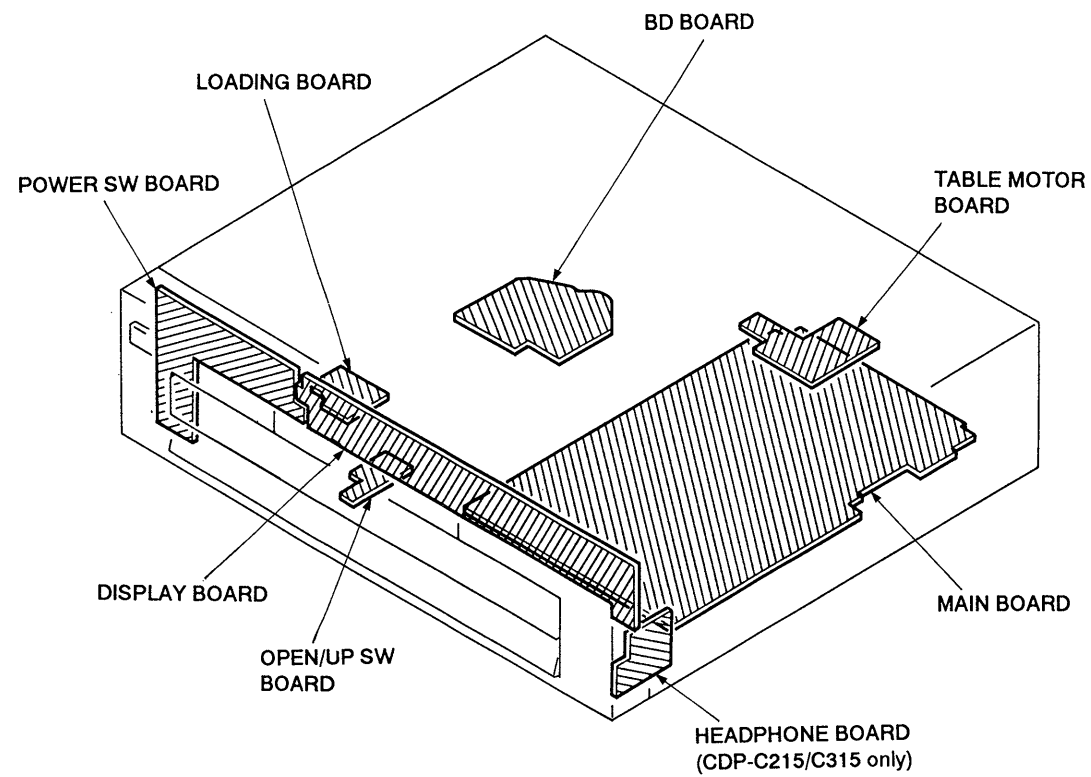

4-3. IC BLOCK DIAGRAMS

IC101 CXA1372Q

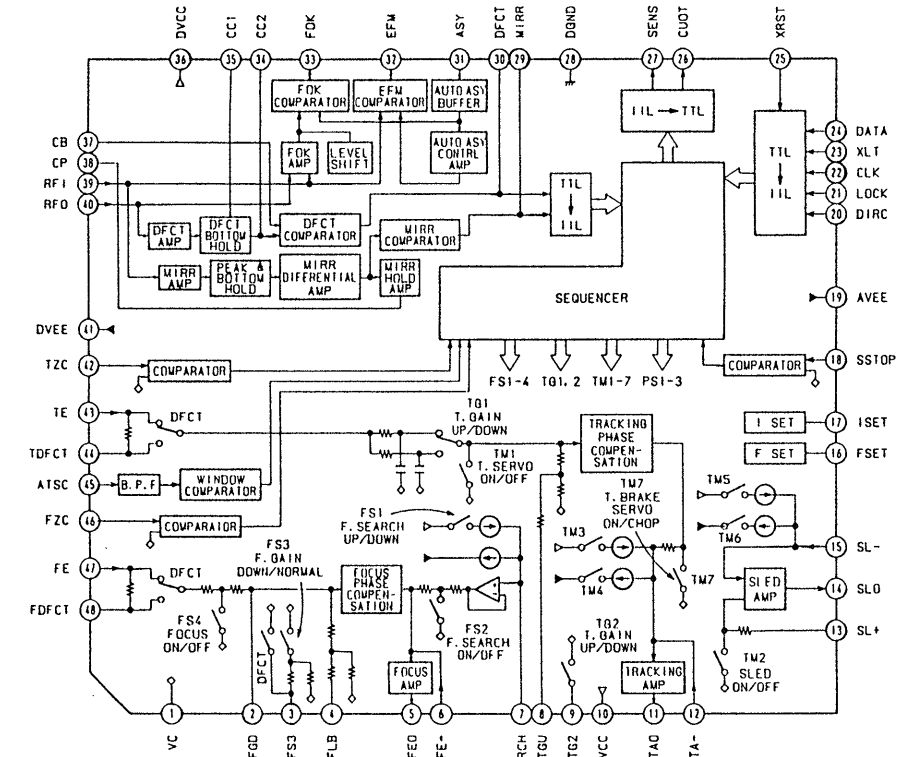

IC102 LA6532M

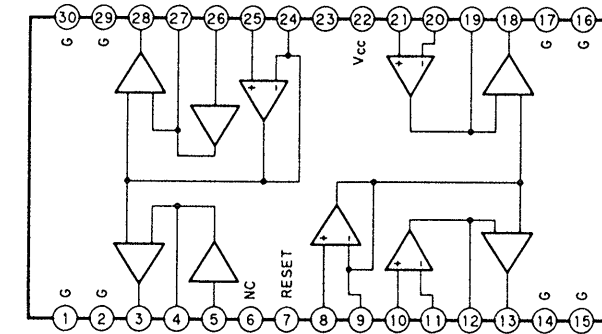

IC201 M5293L

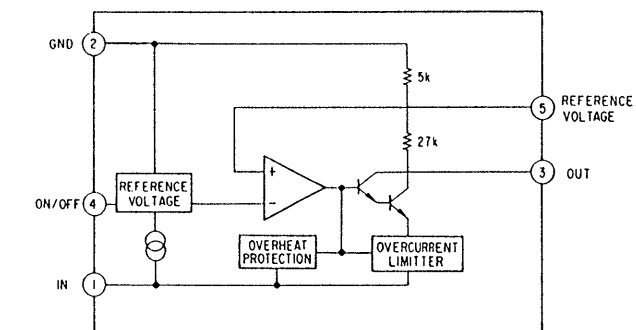

4-2. SEMICONDUCTOR LEAD LAYOUTS

CXA1291P

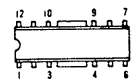

CXD2561M

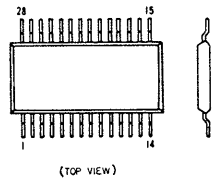

RC4556D
RC5532DD

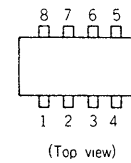

2SB1094-L

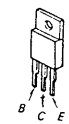

2SD774-34



BR4361F

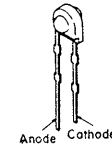

CXD2500AQ
CXP50116-213Q

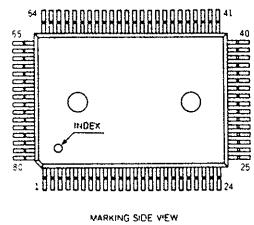

M5293L

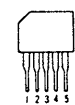

SBX1610-59

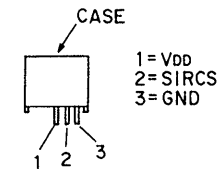

2SC1815-Y
2SC2878-AB



GP-1A521

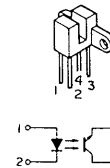

CXD2560M

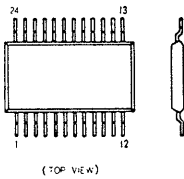

M5F7807L

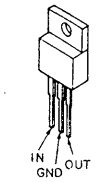

2SA1175-HFE

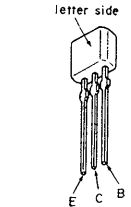

2SC3623-LK
DTA144ES
DTC144ES

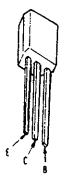

11EQS04
11ES2
1SS120
RD5.6ES-B2
RD6.8ES-B2

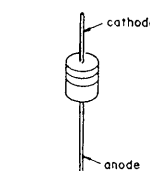

IC202 M5290P-16

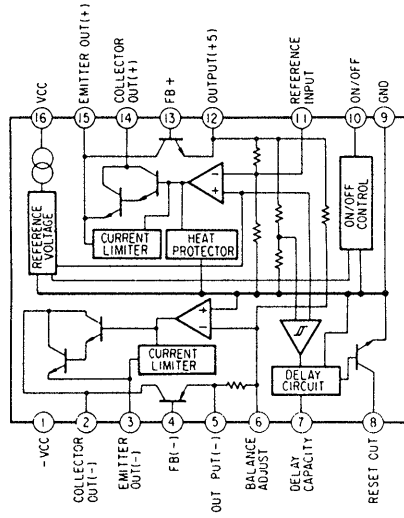

IC301 CXD2500Q

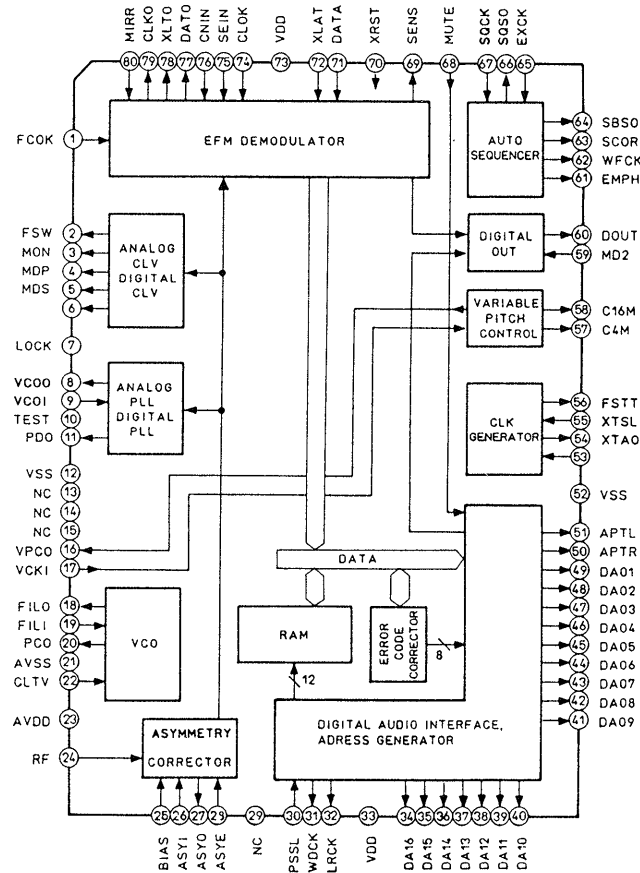

4-4. PRINTED WIRING BOARDS
 • Refer to page 9 for Semiconductor Lead Layouts.

• Semiconductor Location

Ref. No.	Location
D201	I-25
D202	I-25
D203	E-24
D204	E-24
D205	E-24
D206	E-24
D208	E-19
D209	E-19
D341	H-21
D351	H-21
D701	H-30
IC101	D-29
IC102	C-29
IC201	I-24
IC202	F-23
IC203	F-20
IC204	G-24
IC301	J-21
IC302	I-23
IC303	G-21
IC306	F-18
IC307	F-18
IC309	E-17
IC401	I-17
IC402	G-16
IC551	G-14
Q101	E-29
Q201	J-25
Q202	F-23
Q203	E-23
Q204	G-23
Q205	F-23
Q206	F-23
Q209	F-21
Q341	F-16
Q342	F-16
Q343	F-16
Q344	H-21
Q371	G-17
Q372	E-17
Q373	F-17
Q374	F-17
Q375	F-17
Q376	F-17
Q401	I-16

Note:
 ○ — parts extracted from the component side.
 ● — Through hole.
 ▨ — Pattern on the side which is seen.
 ○ — Pattern of the rear side.

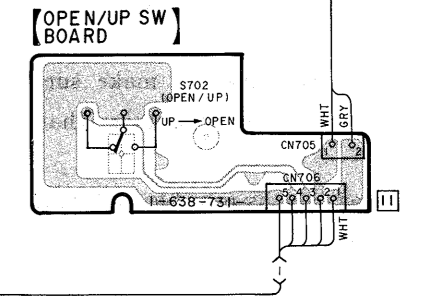
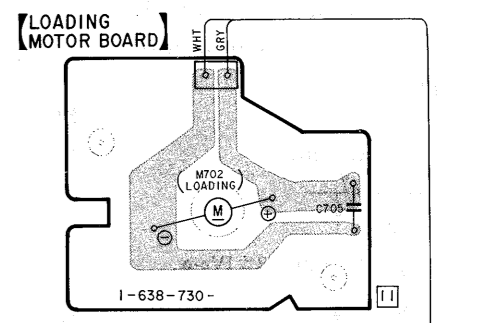
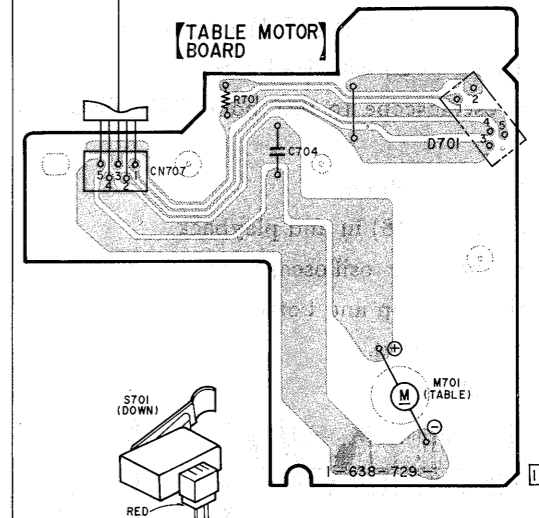
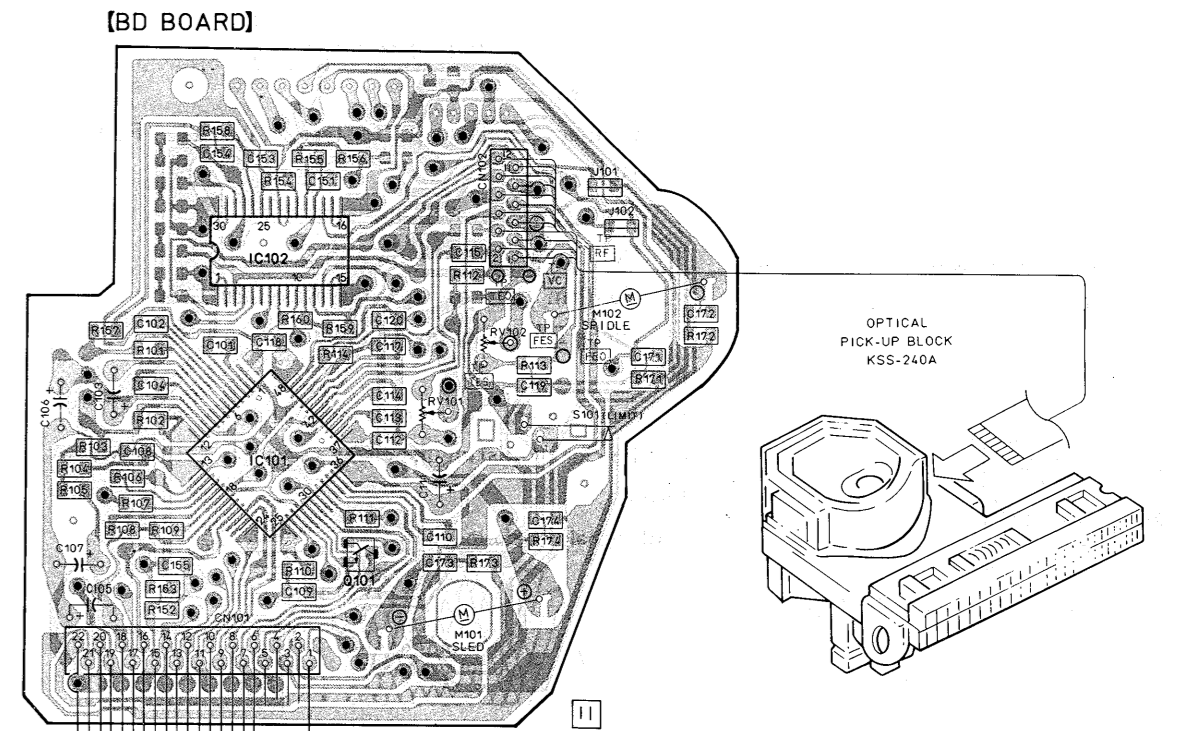
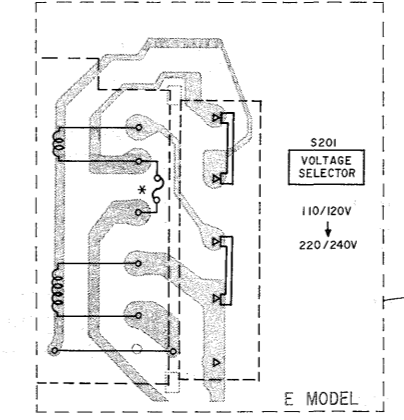
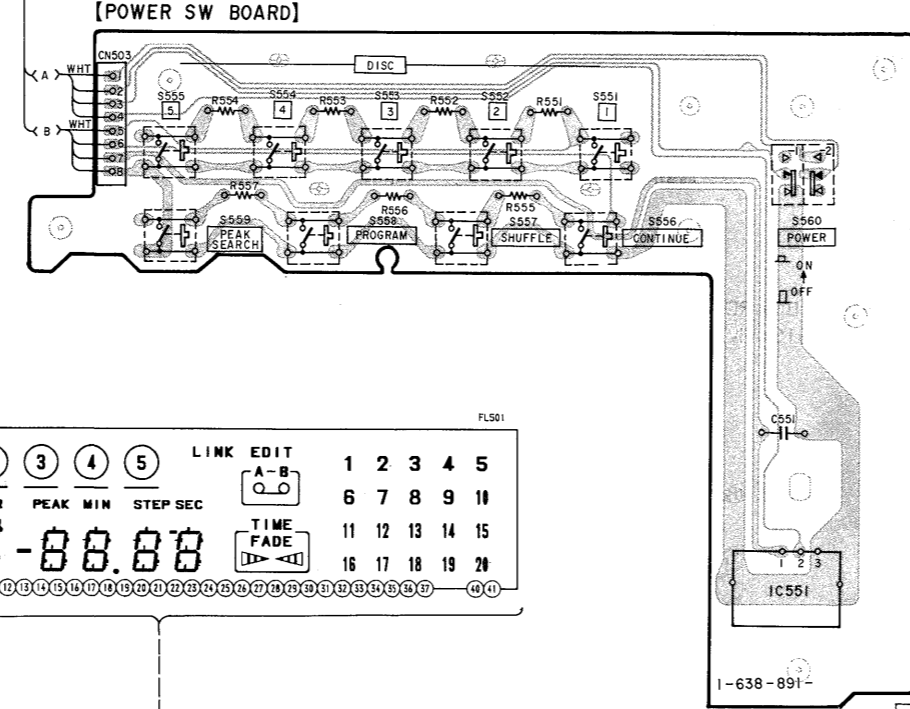
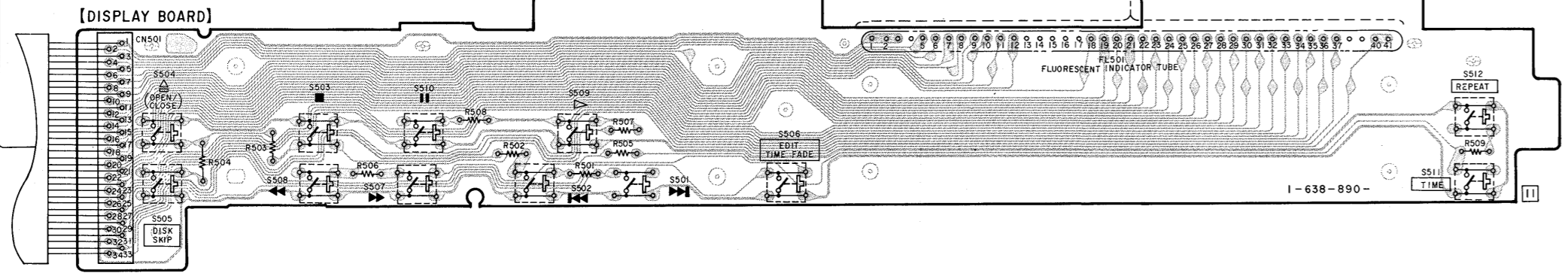
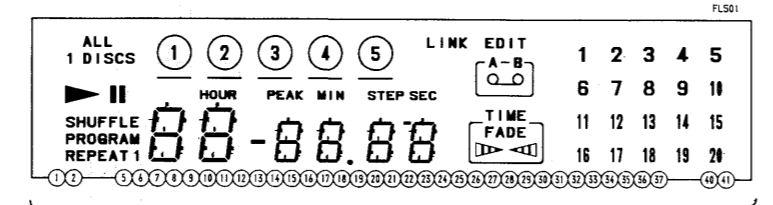
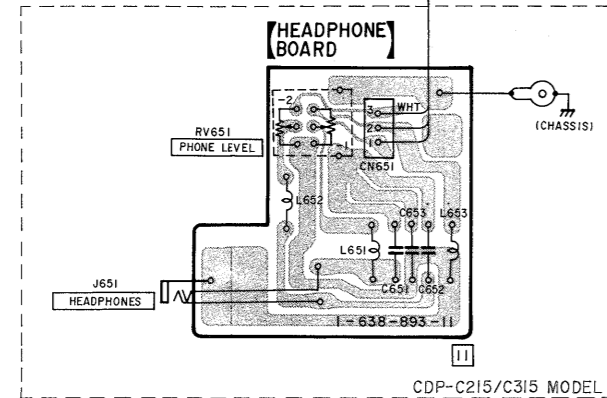
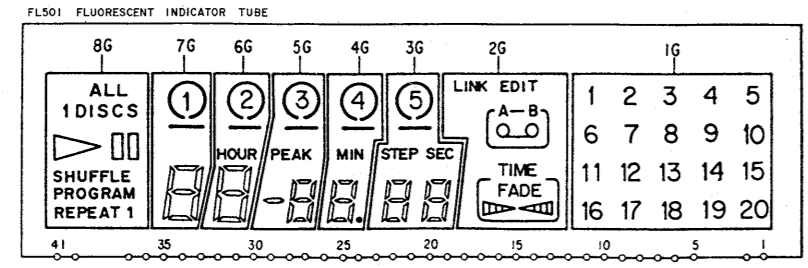
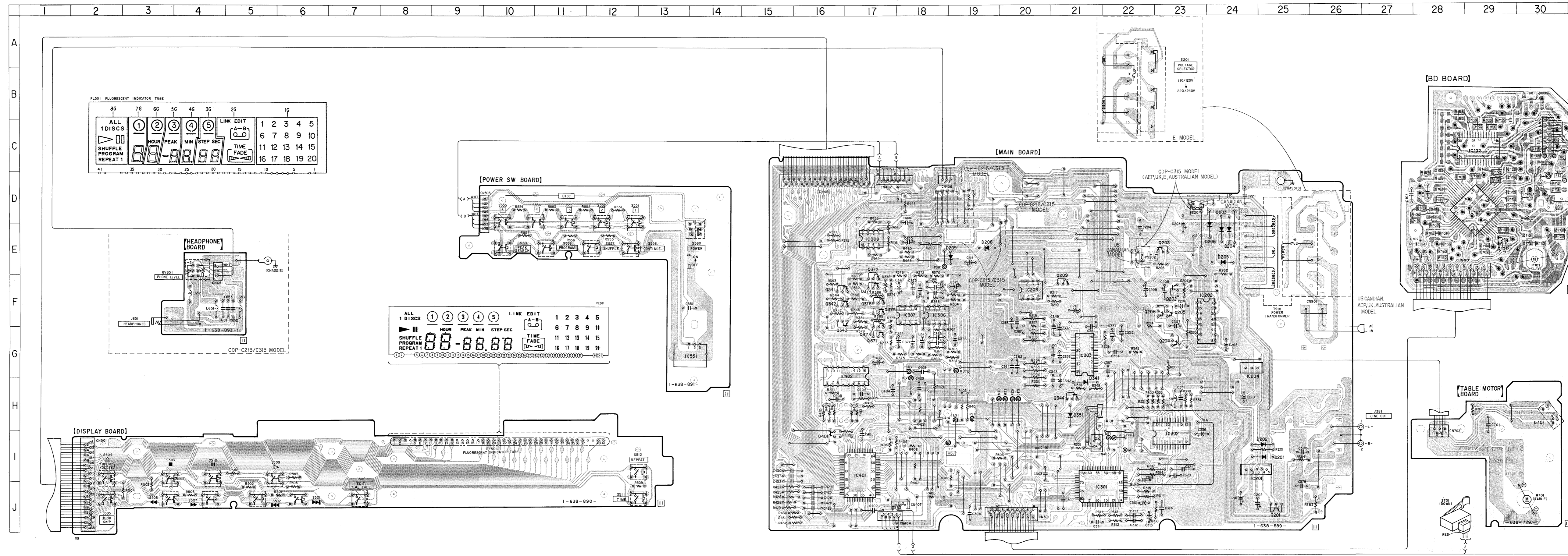

4-5. SCHEMATIC DIAGRAM
 • Refer to page 10 for IC BLOCK Diagrams.

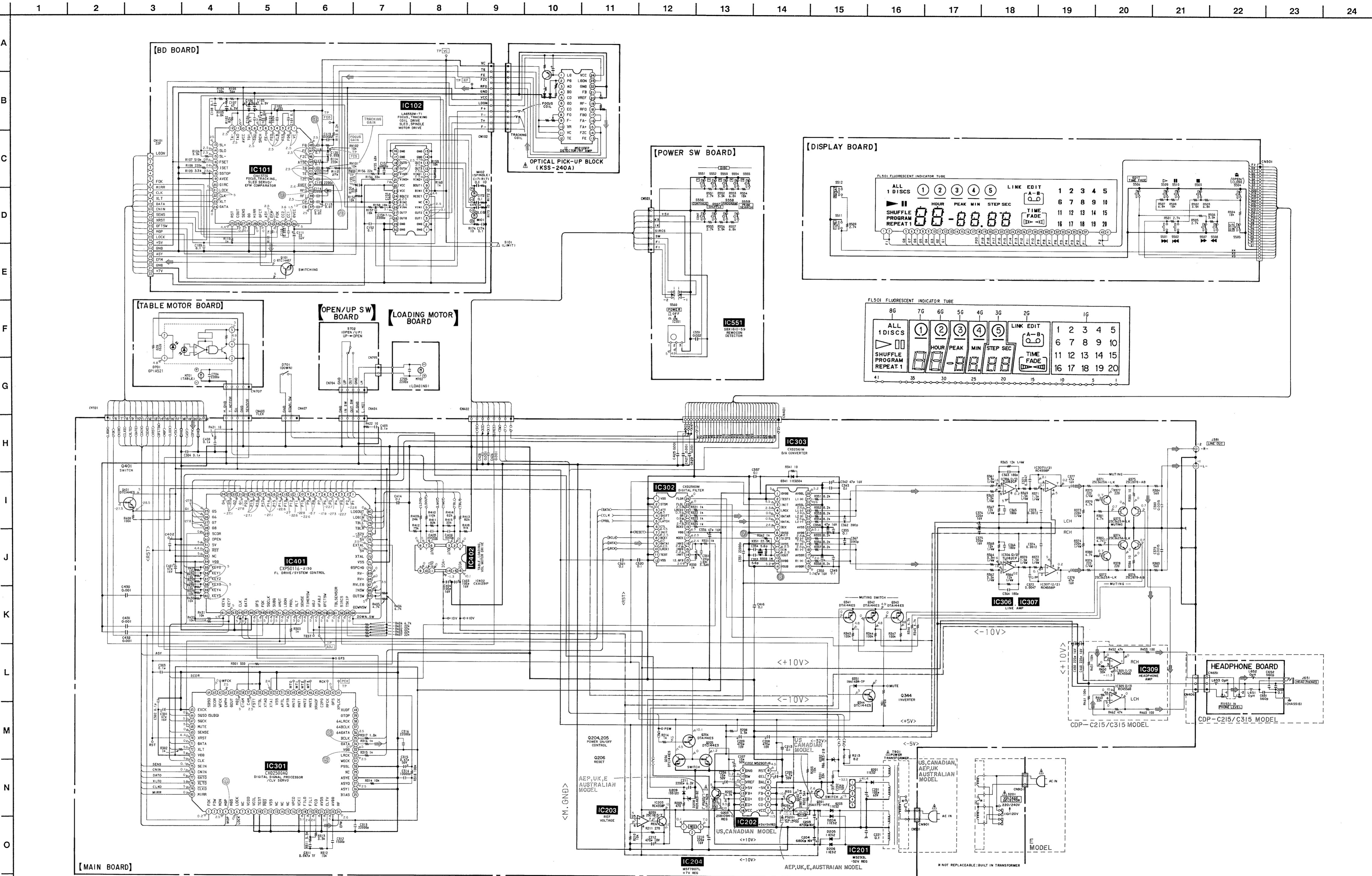

- Note:**
- All capacitors are in μF unless otherwise noted. pF : μF F
 - 50WV or less are not indicated except for electrolytics and tantalums.
 - All resistors are in Ω and $\frac{1}{4}\text{W}$ or less unless otherwise specified.

Note:
 The components identified by mark Δ or dotted line with mark Δ are critical for safety. Replace only with part number specified.

Note:
 Les composants identifiés par une marque Δ sont critiques pour la sécurité. Ne les remplacer que par une pièce portant le numéro spécifié.

- --- : B+ Line
- --- : B- Line
- --- : adjustment for repair.
- Voltage and waveforms are dc with respect to ground under no-signal (detuned) conditions.
- Voltages are taken with a VOM (Input Impedance 10M Ω)
- Voltage variations may be noted due to normal production tolerances.
- Waveforms are taken with an oscilloscope.
- Voltage variations may be noted due to normal production tolerances.
- Circled numbers refer to waveforms.
- Signal path.

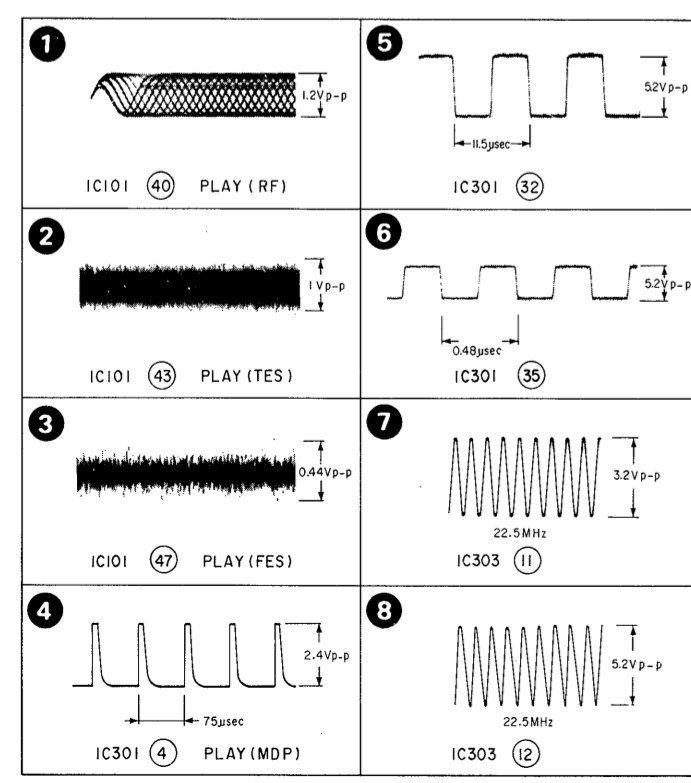

SECTION 5 EXPLODED VIEWS

NOTE:

- -XX, -X mean standardized parts, so they may have some difference from the original one.
- The construction parts of an assembled part are indicated with a collation number in the remark column.
- Items marked " * " are not stocked since they are seldom required for routine service. Some delay should be anticipated when ordering these items.
- The mechanical parts with no reference number in the exploded views are not supplied.
- Hardware (# mark) list is given in the last of this parts list.

The components identified by mark or dotted line with mark are critical for safety. Replace only with part number specified.

Les composants identifiés par une marque sont critiques pour la sécurité. Ne les remplacer que par une pièce portant le numéro spécifié.

5-1. FRONT PANEL AND CASE ASSEMBLIES

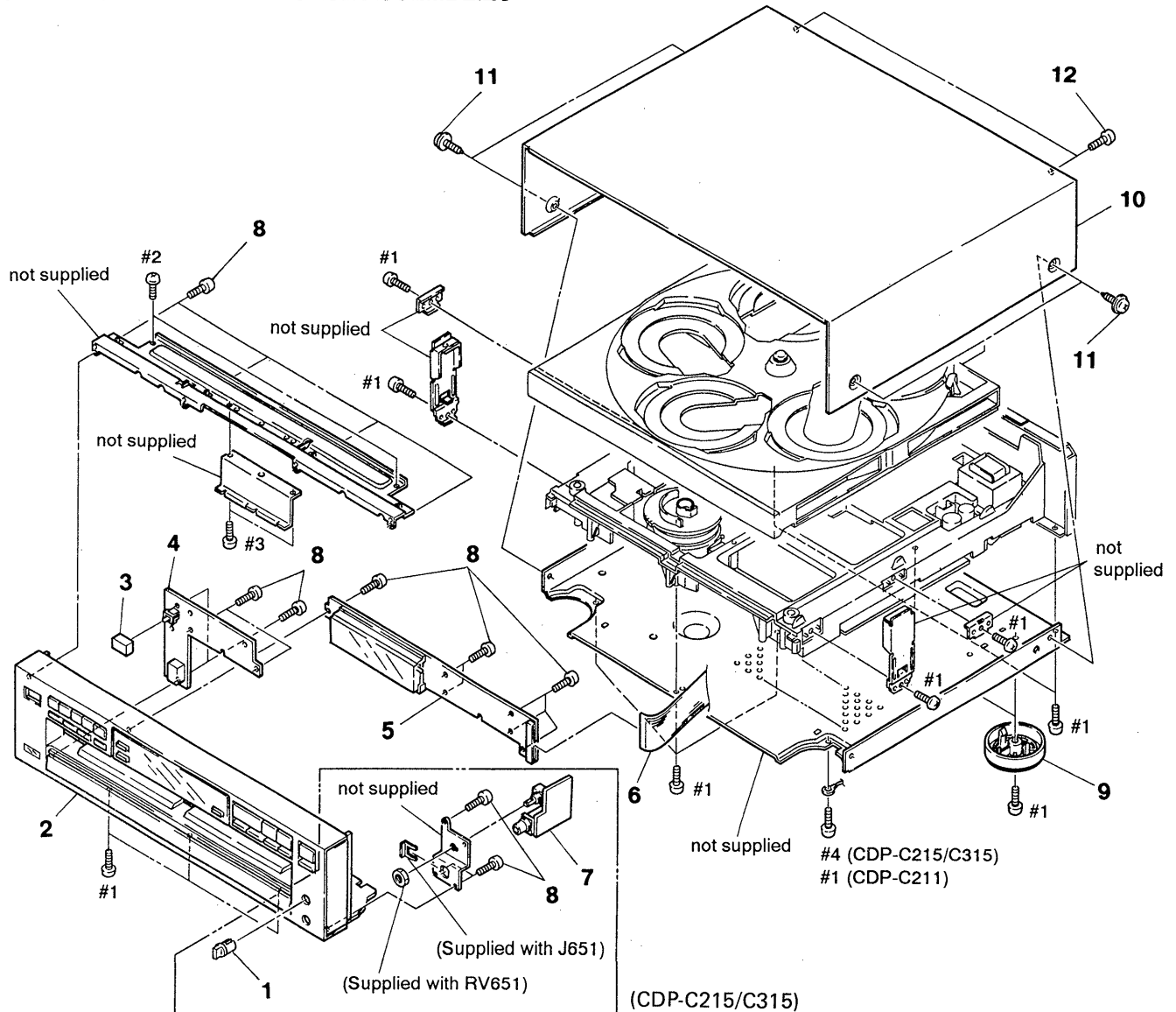

Ref. No.	Part No.	Description	Remark	Ref. No.	Part No.	Description	Remark
1	4-922-531-11	KNOB (A TYPE), VOL (C215/C315)		6	1-590-835-11	WIRE, FLAT TYPE (34 CORE)	
2	X-4941-479-1	PANEL ASSY, FRONT (C315:US, Canadian)		7	* 1-638-893-11	HEADPHONE BOARD (C215/C315)	
2	X-4941-480-1	PANEL ASSY, FRONT (AEP, UK, E. Australian)		8	4-928-635-01	SCREW, +BV (2.6X8) TAPPING	
2	X-4941-481-1	PANEL ASSY, FRONT (C215)		9	X-4924-463-1	FOOT ASSY (AEP, UK, E. Australian)	
2	X-4941-482-1	PANEL ASSY, FRONT (C211)		9	X-4924-464-1	FOOT ASSY (US, Canadian)	
3	4-922-921-01	BUTTON (POWER)		10	* 4-944-153-01	CASE	
4	* 1-638-891-11	POWER SW BOARD		11	3-704-366-01	SCREW (CASE) (M3X8)	
5	* 1-638-890-11	DISPLAY BOARD		12	3-703-685-21	SCREW (+BV 3X8)	

5-2. DISC TRAY ASSEMBLY

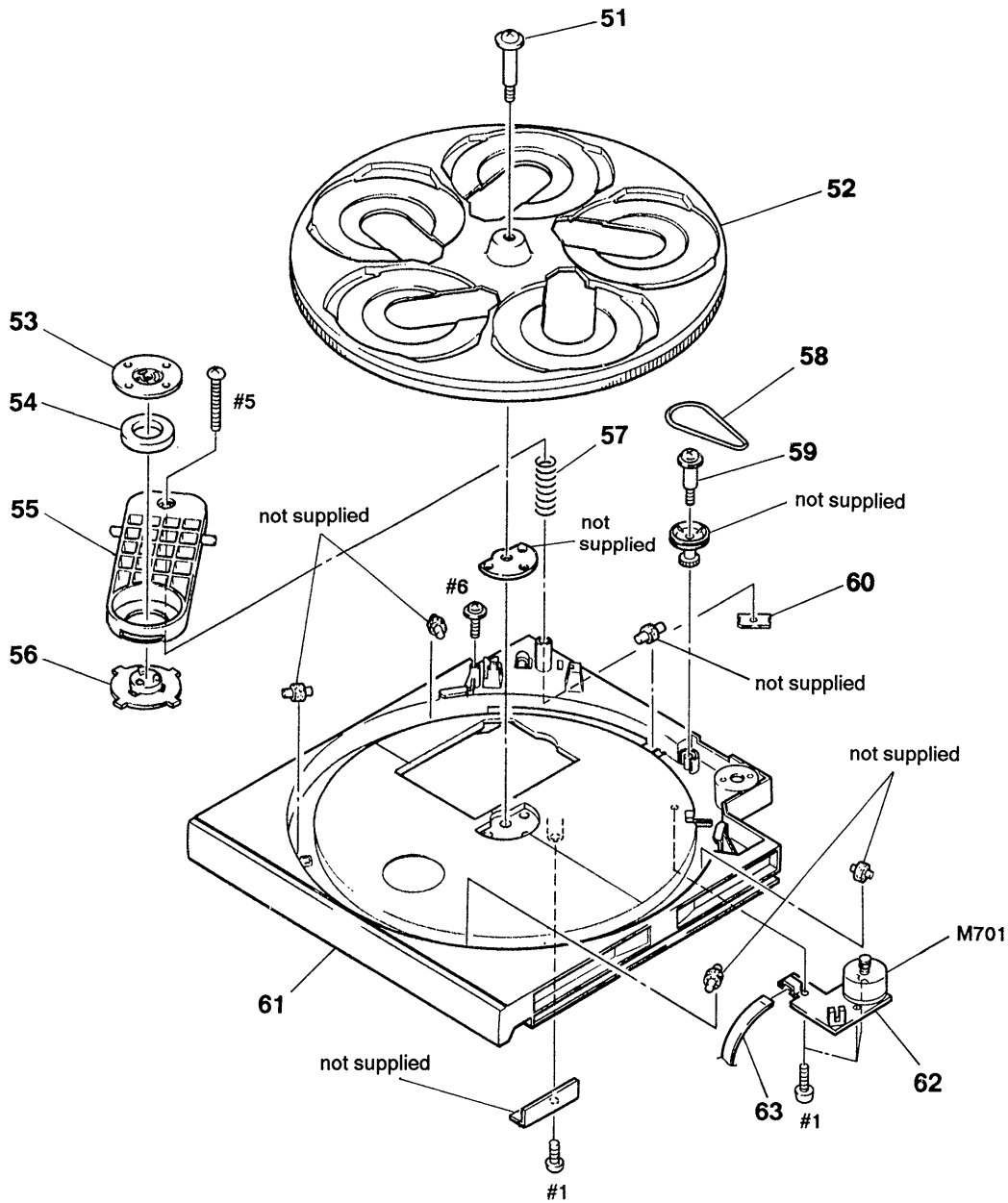

Ref. No.	Part No.	Description	Remark	Ref. No.	Part No.	Description	Remark
51	4-926-384-01	SCREW, STEP		61	4-944-160-11	TABLE (A), DISC (C215)	
52	* 4-926-383-01	TABLE (B), DISK		61	4-944-160-01	TABLE (A), DISC (C211/C315)	
53	4-921-029-01	YOKE, CHUCKING		62	* 1-638-729-11	TABLE MOTOR BOARD	
54	1-452-340-21	MAGNET		63	1-590-849-11	WIRE, FLAT TYPE (5 CORE)	
55	* 4-930-506-02	BRACKET (PRESS PULLEY)		M701	A-4604-585-A	MOTOR ASSY, ROTARY (TABLE)	
56	4-921-022-01	PULLEY, CHUCKING					
57	4-926-395-01	SPRING, COMPRESSION					
58	4-926-399-01	BELT					
59	4-923-597-01	SCREW, STEP					
60	* 4-926-388-01	BRACKET (ADJUSTMENT)					

5-3. CHASSIS ASSEMBLY

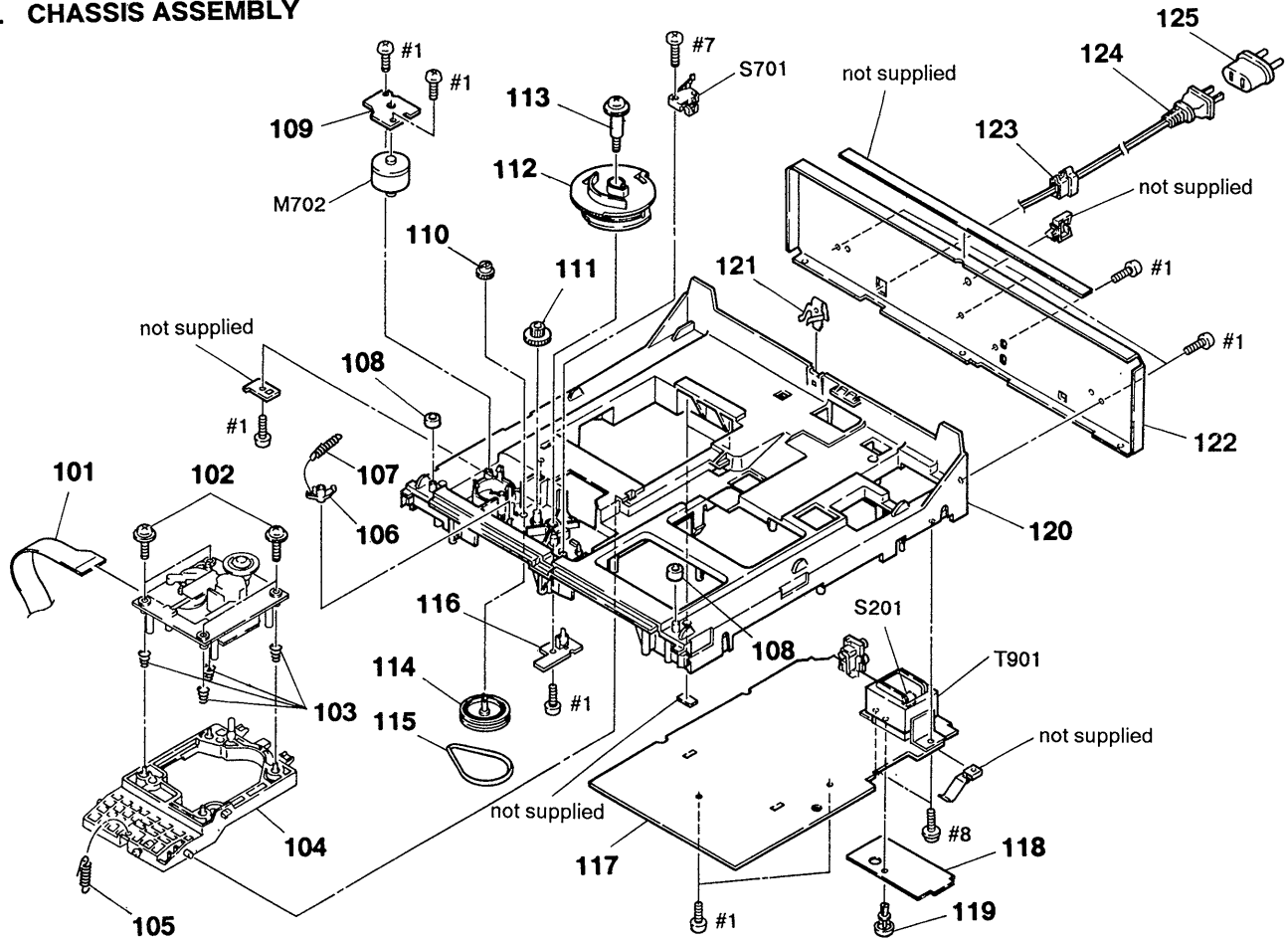

<p>Note: The components identified by mark or dotted line with mark are critical for safety. Replace only with part number specified.</p>	<p>Note: Les composants identifiés par une marque sont critiques pour la sécurité. Ne les remplacer que par une pièce portant le numéro spécifié.</p>
--	---

Ref. No.	Part No.	Description	Remark
101	1-535-892-11	JUMPER, FILM (WITH TERMINAL)	
102	4-933-134-01	SCREW (+PTPWH M2. 6X6)	
103	4-917-541-01	SPRING (B)	
104	* 4-934-373-01	BRACKET (BU)	
105	4-937-911-01	SPRING, TENSION	
106	4-917-519-01	LEVER, SET	
107	4-924-412-01	SPRING (B). TENSION	
108	* 4-934-382-01	CUSHION	
109	* 1-638-730-11	LOADING MOTOR BOARD	
110	4-934-375-01	GEAR (LOADING B)	
111	4-934-381-01	GEAR (LOADING C)	
112	4-934-391-01	GEAR (LOADING A)	
113	4-926-317-01	SCREW, STEP	
114	X-4941-529-1	PULLEY ASSY	
115	4-944-490-01	BELT (TIMING)	
116	* 1-638-731-11	OPEN/UP SW BOARD	
117	* A-4617-825-A	MAIN BOARD, COMPLETE (AEP, UK, Australian)	
117	* A-4617-826-A	MAIN BOARD, COMPLETE (E)	
117	* A-4617-820-A	MAIN BOARD, COMPLETE (US, Canadian)	
118	* 4-944-178-01	SHEET (INSULATING)	
119	3-531-576-11	RIVET	
120	* 4-943-997-01	CHASSIS	
121	* 4-943-996-01	SPRING, LEAF	

Ref. No.	Part No.	Description	Remark
122	* 4-943-681-51	PANEL, BACK (C215:US)	
122	* 4-943-681-61	PANEL, BACK (C211)	
122	* 4-943-681-71	PANEL, BACK (C215:Canadian)	
122	* 4-943-681-41	PANEL, BACK (E)	
122	* 4-943-681-21	PANEL, BACK (AEP)	
122	* 4-943-681-31	PANEL, BACK (UK, Australian)	
122	* 4-943-681-11	PANEL, BACK (C315:Canadian)	
122	* 4-943-681-01	PANEL, BACK (C315:US)	
123	* 3-703-571-12	BUSHING (S) (4516), CORD (E)	
123	* 3-703-244-00	BUSHING (2104), CORD (US, Canadian, AEP, UK, Australian)	
124	1-574-358-31	CORD, POWER (WITH CONNECTOR) (Australian)	
124	1-575-653-21	CORD, POWER (E)	
124	1-575-651-21	CORD, POWER (AEP)	
124	1-558-946-21	CORD, POWER (UK)	
124	1-590-836-11	CORD, POWER (US, Canadian)	
125	1-569-007-11	ADAPTOR, CONVERSION 2P (E)	
M702	A-4604-834-A	MOTOR ASSY, LOADING	
S201	1-571-722-11	SWITCH, VOLTAGE SELECTION (E)	
S701	1-572-713-11	SWITCH, PUSH (WITH CONNECTOR) (DOWN)	
T901	1-449-956-11	TRANSFORMER, POWER (E)	
T901	1-449-955-11	TRANSFORMER, POWER (AEP, UK, Australian)	
T901	1-449-954-11	TRANSFORMER, POWER (US, Canadian)	

5-4. OPTICAL PICK-UP BLOCK ASSEMBLY
(BU-5BD3)

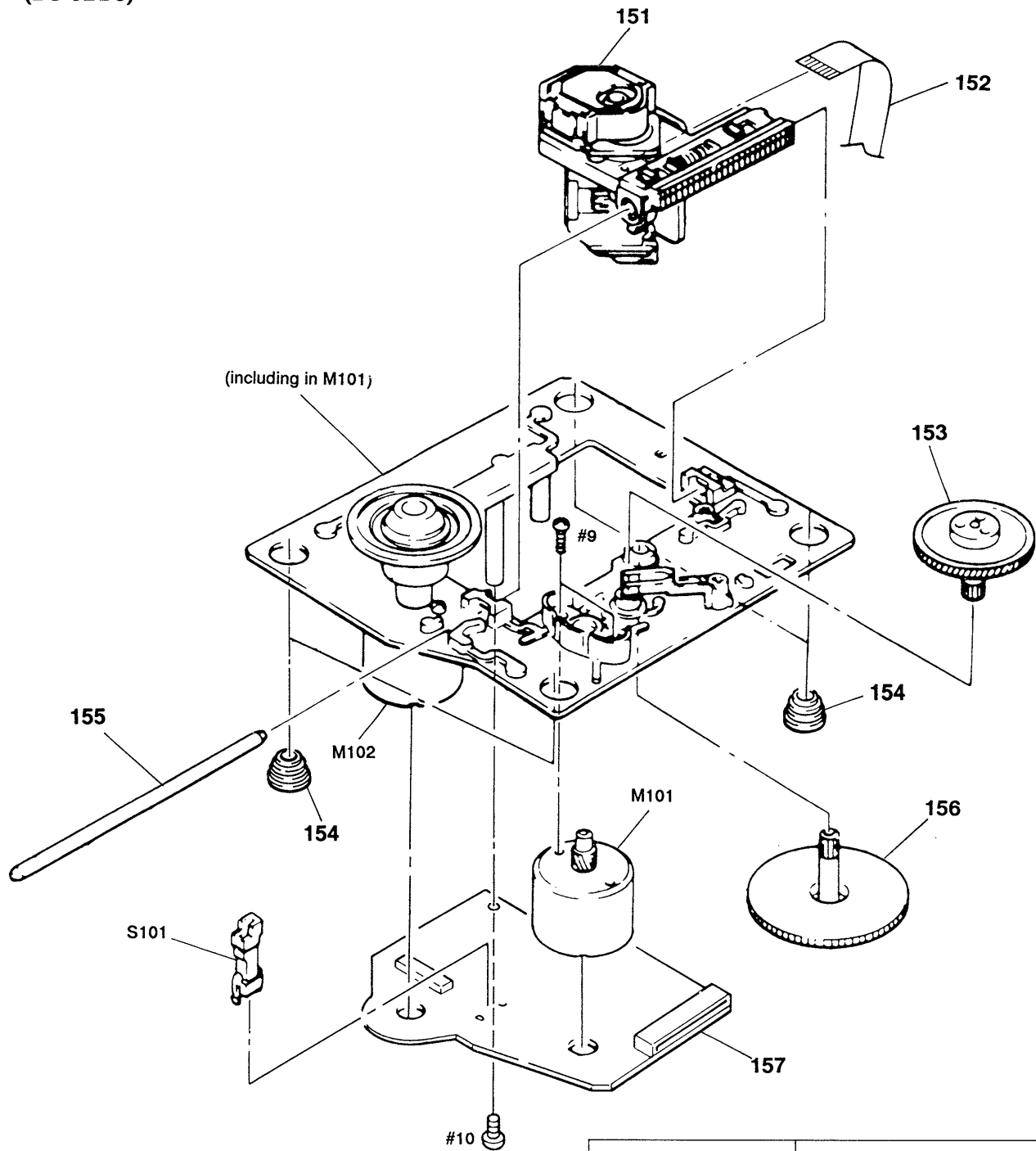

<p>Note: The components identified by mark Δ or dotted line with mark Δ are critical for safety. Replace only with part number specified.</p>	<p>Note: Les composants identifiés par une marque Δ sont critiques pour la sécurité. Ne les remplacer que par une pièce portant le numéro spécifié.</p>
--	--

Ref. No.	Part No.	Description	Remark
151	Δ 8-848-144-11	DEVICE, OPTICAL KSS-240A	
152	1-575-001-11	WIRE, FLAT TYPE (12 CORE)	
153	4-917-567-01	GEAR (M)	
154	4-933-126-01	INSULATOR (A)	
155	4-917-565-01	SHAFT, SLED	

Ref. No.	Part No.	Description	Remark
156	4-917-564-01	GEAR (P), FLATNESS	
157	* A-4617-371-A	BD BOARD, COMPLETE	
M101	X-4917-504-1	MOTOR ASSY (SLED)	
M102	X-4917-523-3	BASE (OUTSERT) ASSY (SPINDLE MOTOR)	
S101	1-572-085-11	SWITCH, LEAF (LIMIT IN)	

SECTION 6 ELECTRICAL PARTS LIST

BD

NOTE:

The components identified by mark or dotted line with mark are critical for safety. Replace only with part number specified.

Les composants identifiés par une marque sont critiques pour la sécurité. Ne les remplacer que par une pièce portant le numéro spécifié.

When indicating parts by reference number, please include the board name.

- Due to standardization, replacements in the parts list may be different from the parts specified in the diagrams or the components used on the set.
- -XX, -X mean standardized parts, so they may have some difference from the original one.
- **RESISTORS**
All resistors are in ohms
METAL: Metal-film resistor
METAL OXIDE: Metal Oxide-film resistor
F : nonflammable
- Items marked "*" are not stocked since they are seldom required for routine service. Some delay should be anticipated when ordering these items.
- **SEMICONDUCTORS**
In each case, u: μ , for example:
uA...: μ A..., uPA...: μ PA...,
uPB...: μ PB..., uPC...: μ PC...,
uPD...: μ PD...
- **CAPACITORS**
uF : μ F
- **COILS**
uH : μ H

Ref. No.	Part No.	Description	Remark	Ref. No.	Part No.	Description	Remark
	* A-4617-371-A	BD BOARD, COMPLETE *****				< CONNECTOR >	
		< CAPACITOR >					
C101	1-163-038-00	CERAMIC CHIP	0.1uF 25V			< IC >	
C102	1-163-989-11	CERAMIC CHIP	0.033uF 10% 25V				
C103	1-126-163-11	ELECT	4.7uF 20% 50V	IC101	8-752-050-82	IC CXA1372Q	
C104	1-163-038-00	CERAMIC CHIP	0.1uF 25V	IC102	8-759-822-36	IC LA6532M	
C105	1-126-154-11	ELECT	47uF 20% 6.3V			< JAMPER >	
C106	1-126-154-11	ELECT	47uF 20% 6.3V	J101	1-216-295-00	METAL CHIP 0	5% 1/10W
C107	1-126-154-11	ELECT	47uF 20% 6.3V	J102	1-216-295-00	METAL CHIP 0	5% 1/10W
C108	1-163-038-00	CERAMIC CHIP	0.1uF 25V			< TRANSISTOR >	
C109	1-163-038-00	CERAMIC CHIP	0.1uF 25V				
C110	1-163-989-11	CERAMIC CHIP	0.033uF 10% 25V	Q101	8-729-901-01	TRANSISTOR DTC144EK	
C111	1-131-367-00	TANTALUM	22uF 10% 20V			< RESISTOR >	
C112	1-164-232-11	CERAMIC CHIP	0.01uF 50V				
C113	1-164-232-11	CERAMIC CHIP	0.01uF 50V	R101	1-216-097-00	METAL CHIP 100K	5% 1/10W
C114	1-164-161-11	CERAMIC CHIP	0.0022uF 10% 100V	R102	1-216-095-00	METAL CHIP 82K	5% 1/10W
C115	1-164-161-11	CERAMIC CHIP	0.0022uF 10% 100V	R103	1-216-091-00	METAL CHIP 56K	5% 1/10W
C117	1-163-038-00	CERAMIC CHIP	0.1uF 25V	R104	1-216-099-00	METAL CHIP 120K	5% 1/10W
C118	1-163-038-00	CERAMIC CHIP	0.1uF 25V	R105	1-216-069-00	METAL CHIP 6.8K	5% 1/10W
C119	1-164-161-11	CERAMIC CHIP	0.0022uF 10% 100V	R106	1-216-061-00	METAL CHIP 3.3K	5% 1/10W
C120	1-163-989-11	CERAMIC CHIP	0.033uF 10% 25V	R107	1-216-114-00	METAL GLAZE 510K	5% 1/10W
C151	1-163-019-00	CERAMIC CHIP	0.0068uF 10% 50V	R108	1-216-105-00	METAL CHIP 220K	5% 1/10W
C152	1-163-038-00	CERAMIC CHIP	0.1uF 25V	R109	1-216-061-00	METAL CHIP 3.3K	5% 1/10W
C153	1-163-006-11	CERAMIC CHIP	560PF 10% 50V	R110	1-216-049-00	METAL CHIP 1K	5% 1/10W
C154	1-164-161-11	CERAMIC CHIP	0.0022uF 10% 100V	R111	1-216-049-00	METAL CHIP 1K	5% 1/10W
C155	1-163-023-00	CERAMIC CHIP	0.015uF 5% 50V	R112	1-216-083-00	METAL CHIP 27K	5% 1/10W
C171	1-163-038-00	CERAMIC CHIP	0.1uF 25V	R113	1-216-071-00	METAL CHIP 8.2K	5% 1/10W
C172	1-163-038-00	CERAMIC CHIP	0.1uF 25V	R114	1-216-105-00	METAL CHIP 220K	5% 1/10W
C173	1-163-038-00	CERAMIC CHIP	0.1uF 25V	R152	1-216-073-00	METAL CHIP 10K	5% 1/10W
C174	1-163-038-00	CERAMIC CHIP	0.1uF 25V				

BD MAIN DISPLAY POWER SW HEADPHONE

Ref. No.	Part No.	Description	Remark	Ref. No.	Part No.	Description	Remark
R153	1-216-085-00	METAL CHIP	33K 5% 1/10W	C211	1-124-893-11	ELECT	2200uF 20% 10V
R154	1-216-085-00	METAL CHIP	33K 5% 1/10W	C212	1-124-997-11	ELECT	470uF 20% 10V
R155	1-216-093-00	METAL CHIP	68K 5% 1/10W	C213	1-164-159-11	CERAMIC	0.1uF 50V
R156	1-216-081-00	METAL CHIP	22K 5% 1/10W	C221	1-164-159-11	CERAMIC	0.1uF 50V
R157	1-216-079-00	METAL CHIP	18K 5% 1/10W	C301	1-126-022-11	ELECT	47uF 20% 16V
R158	1-216-079-00	METAL CHIP	18K 5% 1/10W	C302	1-164-159-11	CERAMIC	0.1uF 50V
R159	1-216-079-00	METAL CHIP	18K 5% 1/10W	C303	1-164-159-11	CERAMIC	0.1uF 50V
R160	1-216-049-00	METAL CHIP	1K 5% 1/10W	C304	1-164-159-11	CERAMIC	0.1uF 50V
R171	1-216-001-00	METAL CHIP	10 5% 1/10W	C311	1-136-161-00	FILM	0.047uF 5% 50V
R172	1-216-001-00	METAL CHIP	10 5% 1/10W	C312	1-161-374-11	CERAMIC	0.0015uF 20% 50V
R173	1-216-001-00	METAL CHIP	10 5% 1/10W	C313	1-161-494-00	CERAMIC	0.022uF 25V
R174	1-216-001-00	METAL CHIP	10 5% 1/10W	C314	1-162-306-11	CERAMIC	0.01uF 20% 16V
		< VARIABLE RESISTOR >		C315	1-126-300-11	ELECT	0.47uF 20% 50V
RV101	1-238-016-11	RES. ADJ. CARBON 10K		C316	1-161-494-00	CERAMIC	0.022uF 25V
RV102	1-238-016-11	RES. ADJ. CARBON 10K		C320	1-164-159-11	CERAMIC	0.1uF 50V
		< SWITCH >		C321	1-164-159-11	CERAMIC	0.1uF 50V
S101	1-572-085-11	SWITCH, LEAF (LIMIT)		C331	1-162-208-31	CERAMIC	24PF 5% 50V
		*****		C336	1-126-022-11	ELECT	47uF 20% 16V
		* A-4617-820-A MAIN BOARD, COMPLETE (C211)		C342	1-126-022-11	ELECT	47uF 20% 16V
		* A-4617-820-A MAIN BOARD, COMPLETE (C215/C315:		C343	1-164-159-11	CERAMIC	0.1uF 50V
		US, Canadian)		C349	1-164-159-11	CERAMIC	0.1uF 50V
		* A-4617-825-A MAIN BOARD, COMPLETE (C315:		C350	1-126-022-11	ELECT	47uF 20% 16V
		AEP, UK, Australian)		C351	1-161-494-00	CERAMIC	0.022uF 25V
		* A-4617-826-A MAIN BOARD, COMPLETE (C315:E)		C353	1-162-196-31	CERAMIC	5.6PF 10% 50V
		*****		C354	1-162-196-31	CERAMIC	5.6PF 10% 50V
		* 1-638-890-11 DISPLAY BOARD		C355	1-164-159-11	CERAMIC	0.1uF 50V
		*****		C356	1-126-022-11	ELECT	47uF 20% 16V
		* 1-638-891-11 POWER SW BOARD		C357	1-161-772-11	CERAMIC	0.1uF 10% 25V
		*****		C362	1-162-289-31	CERAMIC	390PF 10% 50V
		* 1-638-893-11 HEADPHONE BOARD (C215/C315)		C363	1-162-285-31	CERAMIC	180PF 10% 50V
		*****		C364	1-162-285-31	CERAMIC	180PF 10% 50V
		* 4-875-327-01 HEAT SINK		C365	1-162-285-31	CERAMIC	180PF 10% 50V
		7-682-547-04 SCREW +BVTT 3X6 (S)		C366	1-162-285-31	CERAMIC	180PF 10% 50V
		< CAPACITOR >		C367	1-162-289-31	CERAMIC	390PF 10% 50V
C201	1-124-572-11	ELECT	100uF 20% 63V	C371	1-130-479-00	MYLAR	0.0047uF 5% 50V
C202	1-126-059-11	ELECT	10uF 20% 50V	C372	1-130-479-00	MYLAR	0.0047uF 5% 50V
C203	1-126-937-11	ELECT	4700uF 20% 16V	C373	1-130-472-00	MYLAR	0.0012uF 5% 50V
C204	1-126-017-11	ELECT	6800uF 20% 16V	C374	1-130-472-00	MYLAR	0.0012uF 5% 50V
C205	1-126-163-11	ELECT	4.7uF 20% 50V	C375	1-126-024-11	ELECT	220uF 20% 16V
C206	1-126-059-11	ELECT	10uF 20% 50V	C376	1-126-024-11	ELECT	220uF 20% 16V
C207	1-126-059-11	ELECT	10uF 20% 50V	C377	1-126-022-11	ELECT	47uF 20% 16V
C208	1-124-997-11	ELECT	470uF 20% 10V	C378	1-126-022-11	ELECT	47uF 20% 16V
C209	1-124-997-11	ELECT	470uF 20% 10V	C379	1-130-473-00	MYLAR	0.0015uF 5% 50V
C210	1-126-024-11	ELECT	220uF 20% 16V	C380	1-130-473-00	MYLAR	0.0015uF 5% 50V
				C401	1-126-022-11	ELECT	47uF 20% 16V
				C402	1-164-159-11	CERAMIC	0.1uF 50V
				C403	1-126-023-11	ELECT	100uF 20% 16V
				C404	1-126-023-11	ELECT	100uF 20% 16V
				C405	1-162-294-31	CERAMIC	0.001uF 10% 50V

MAIN

DISPLAY

POWER SW

HEADPHONE

Ref. No.	Part No.	Description	Remark
C406	1-162-294-31	CERAMIC 0.001uF 10% 50V	
C408	1-164-159-11	CERAMIC 0.1uF 50V	
C409	1-164-159-11	CERAMIC 0.1uF 50V	
C414	1-164-159-11	CERAMIC 0.1uF 50V	
C416	1-164-159-11	CERAMIC 0.1uF 50V	
C425	1-162-294-31	CERAMIC 0.001uF 10% 50V	
C426	1-162-294-31	CERAMIC 0.001uF 10% 50V	
C427	1-162-294-31	CERAMIC 0.001uF 10% 50V	
C428	1-162-294-31	CERAMIC 0.001uF 10% 50V	
C429	1-162-294-31	CERAMIC 0.001uF 10% 50V	
C430	1-162-294-31	CERAMIC 0.001uF 10% 50V	
C431	1-162-294-31	CERAMIC 0.001uF 10% 50V	
C432	1-162-294-31	CERAMIC 0.001uF 10% 50V	
C450	1-126-024-11	ELECT 220uF 20% 16V (C215/C315)	
C460	1-126-024-11	ELECT 220uF 20% 16V (C215/C315)	
C551	1-161-494-00	CERAMIC 0.022uF 25V	
C651	1-162-291-31	CERAMIC 560PF 10% 50V (C215/C315)	
C652	1-162-291-31	CERAMIC 560PF 10% 50V (C215/C315)	
C653	1-164-159-11	CERAMIC 0.1uF 50V (C215/C315)	

< CONNECTOR >

CN301	* 1-573-046-11	SOCKET, CONNECTOR 18P	
CN401	* 1-573-080-11	SOCKET, CONNECTOR (34P, L TYPE)	
CN402	* 1-568-946-11	PIN, CONNECTOR 8P	
CN403	* 1-568-824-11	SOCKET, CONNECTOR 5P	
CN404	* 1-568-943-11	PIN, CONNECTOR 5P	

CN406	* 1-568-941-11	PIN, CONNECTOR 3P (C215/C315)	
CN501	* 1-573-080-11	SOCKET, CONNECTOR (34P, L TYPE)	
CN901	* 1-573-047-11	PIN, CONNECTOR	

< DIODE >

D201	8-719-200-82	DIODE 11ES2	
D202	8-719-109-97	DIODE RD6. 8ES-2B	
D203	8-719-200-82	DIODE 11ES2	
D204	8-719-200-82	DIODE 11ES2	
D205	8-719-200-82	DIODE 11ES2	
D206	8-719-200-82	DIODE 11ES2	
D208	8-719-109-89	DIODE RD5. 6ES-B2	
D209	8-719-912-20	DIODE 1SS120	
D341	8-719-210-21	DIODE 11EQS04	
D351	8-719-912-20	DIODE 1SS120	

< FLUORESCENT INDICATOR >

FL501	1-519-655-11	FLUORESCENT INDICATOR	
-------	--------------	-----------------------	--

Ref. No.	Part No.	Description	Remark
		< IC >	
IC201	8-759-633-42	IC M5293L	
IC202	8-759-630-21	IC M5290P-16	
IC203	8-759-945-58	IC RC4558P	
IC204	8-759-604-86	IC M5F7807L	
IC301	8-752-337-26	IC CXD2500AQ	
IC302	8-752-342-65	IC CXD2560M	
IC303	8-752-343-01	IC CXD2561M	
IC306	8-759-990-82	IC TL082CP	
IC307	8-759-945-58	IC RC4558P	
IC309	8-759-981-85	IC RC4556D (C215/C315)	
IC401	8-752-817-42	IC CXP50116-2130	
IC402	8-759-821-32	IC CXA-1291P	
IC551	8-741-100-48	IC SBX1610-59	

< JACK >

J381	1-569-442-11	JACK, PIN 2P (LINE OUT)	
J651	1-568-519-21	JACK, LARGE TYPE (HEADPHONES) (C215/C315)	

< COIL >

L331	1-408-403-00	INDUCTOR 3.3uH	
L651	1-412-473-21	INDUCTOR 0uH (C215/C315)	
L652	1-412-473-21	INDUCTOR 0uH (C215/C315)	
L653	1-412-473-21	INDUCTOR 0uH (C215/C315)	

< LINK >

PS201	△ 1-532-685-00	LINK, IC ICP-N20 (0.8A) (C315:AEP, UK, Australian, E)	
PS202	△ 1-532-637-00	LINK, IC ICP-N25 (1.0A) (C315:AEP, UK, Australian, E)	

< TRANSISTOR >

Q201	8-729-119-76	TRANSISTOR 2SA1175-HFE	
Q202	8-729-140-96	TRANSISTOR 2SD774-34	
Q203	8-729-111-67	TRANSISTOR 2SB1094-L	
Q204	8-729-900-65	TRANSISTOR DTA144ES	
Q205	8-729-900-89	TRANSISTOR DTC144ES	
Q206	8-729-900-89	TRANSISTOR DTC144ES	
Q209	8-729-281-52	TRANSISTOR 2SC1815-Y	
Q341	8-729-900-65	TRANSISTOR DTA144ES	
Q342	8-729-900-65	TRANSISTOR DTA144ES	
Q343	8-729-900-65	TRANSISTOR DTA144ES	
Q344	8-729-900-89	TRANSISTOR DTC144ES	
Q371	8-729-141-30	TRANSISTOR 2SC3623A-LK	
Q372	8-729-141-30	TRANSISTOR 2SC3623A-LK	
Q373	8-729-141-30	TRANSISTOR 2SC3623A-LK	
Q374	8-729-141-30	TRANSISTOR 2SC3623A-LK	

Note:

The components identified by mark △ or dotted line with mark △ are critical for safety. Replace only with part number specified.

Note:

Les composants identifiés par une marque △ sont critiques pour la sécurité. Ne les remplacer que par une pièce portant le numéro spécifié.

MAIN

DISPLAY

POWER SW

HEADPHONE

Ref. No.	Part No.	Description	Remark	Ref. No.	Part No.	Description	Remark
Q375	8-729-231-55	TRANSISTOR 2SC2878-AB		R358	1-249-428-11	CARBON	8. 2K 5% 1/4W
Q376	8-729-231-55	TRANSISTOR 2SC2878-AB		R359	1-247-903-00	CARBON	1M 5% 1/4W
Q401	8-729-900-89	TRANSISTOR DTC144ES		R361	1-249-423-11	CARBON	3. 3K 5% 1/4W
< RESISTOR >				R362	1-249-423-11	CARBON	3. 3K 5% 1/4W
R201	1-249-435-11	CARBON	33K 5% 1/4W	R363	1-249-423-11	CARBON	3. 3K 5% 1/4W
R202	1-249-438-11	CARBON	56K 5% 1/4W	R364	1-249-423-11	CARBON	3. 3K 5% 1/4W
R203	1-249-429-11	CARBON	10K 5% 1/4W	R365	1-249-430-11	CARBON	12K 5% 1/4W
R204	1-249-425-11	CARBON	4. 7K 5% 1/4W	R366	1-249-430-11	CARBON	12K 5% 1/4W
R205	1-249-425-11	CARBON	4. 7K 5% 1/4W	R367	1-249-430-11	CARBON	12K 5% 1/4W
R208	1-249-423-11	CARBON	3. 3K 5% 1/4W	R368	1-249-430-11	CARBON	12K 5% 1/4W
R209	1-249-413-11	CARBON	470 5% 1/4W	R369	1-249-419-11	CARBON	1. 5K 5% 1/4W
R210	1-249-429-11	CARBON	10K 5% 1/4W	R370	1-249-419-11	CARBON	1. 5K 5% 1/4W
R211	1-249-410-11	CARBON	270 5% 1/4W	R371	1-249-419-11	CARBON	1. 5K 5% 1/4W
R212	1-249-392-11	CARBON	8. 2 5% 1/4W	R372	1-249-419-11	CARBON	1. 5K 5% 1/4W
R213	1-249-392-11	CARBON	8. 2 5% 1/4W	R373	1-247-887-00	CARBON	220K 5% 1/4W
R214	1-249-417-11	CARBON	1K 5% 1/4W	R374	1-247-887-00	CARBON	220K 5% 1/4W
R301	1-249-411-11	CARBON	330 5% 1/4W	R375	1-249-409-11	CARBON	220 5% 1/4W
R302	1-249-417-11	CARBON	1K 5% 1/4W	R376	1-249-409-11	CARBON	220 5% 1/4W
R303	1-249-417-11	CARBON	1K 5% 1/4W	R377	1-249-409-11	CARBON	220 5% 1/4W
R311	1-249-423-11	CARBON	3. 3K 5% 1/4W	R378	1-249-409-11	CARBON	220 5% 1/4W
R312	1-249-429-11	CARBON	10K 5% 1/4W	R379	1-249-425-11	CARBON	4. 7K 5% 1/4W
R313	1-249-423-11	CARBON	3. 3K 5% 1/4W	R380	1-249-425-11	CARBON	4. 7K 5% 1/4W
R314	1-249-429-11	CARBON	10K 5% 1/4W	R381	1-249-425-11	CARBON	4. 7K 5% 1/4W
R315	1-249-417-11	CARBON	1K 5% 1/4W	R382	1-249-425-11	CARBON	4. 7K 5% 1/4W
R316	1-249-417-11	CARBON	1K 5% 1/4W	R383	1-249-414-11	CARBON	560 5% 1/4W
R317	1-249-420-11	CARBON	1. 8K 5% 1/4W	R384	1-249-414-11	CARBON	560 5% 1/4W
R318	1-249-441-11	CARBON	100K 5% 1/4W	R385	1-249-393-11	CARBON	10 5% 1/4W
R321	1-249-417-11	CARBON	1K 5% 1/4W	R386	1-249-393-11	CARBON	10 5% 1/4W
R322	1-249-417-11	CARBON	1K 5% 1/4W	R401	1-249-433-11	CARBON	22K 5% 1/4W
R323	1-249-417-11	CARBON	1K 5% 1/4W	R402	1-249-433-11	CARBON	22K 5% 1/4W
R324	1-249-417-11	CARBON	1K 5% 1/4W	R403	1-249-433-11	CARBON	22K 5% 1/4W
R330	1-249-417-11	CARBON	1K 5% 1/4W	R404	1-249-425-11	CARBON	4. 7K 5% 1/4W
R331	1-249-417-11	CARBON	1K 5% 1/4W	R405	1-249-425-11	CARBON	4. 7K 5% 1/4W
R341	1-249-393-11	CARBON	10 5% 1/4W	R406	1-249-425-11	CARBON	4. 7K 5% 1/4W
R342	1-249-417-11	CARBON	1K 5% 1/4W	R407	1-249-433-11	CARBON	22K 5% 1/4W
R343	1-249-441-11	CARBON	100K 5% 1/4W	R408	1-249-441-11	CARBON	100K 5% 1/4W
R344	1-249-441-11	CARBON	100K 5% 1/4W	R409	1-247-864-11	CARBON	24K 5% 1/4W
R345	1-249-425-11	CARBON	4. 7K 5% 1/4W	R410	1-247-880-11	CARBON	110K 5% 1/4W
R346	1-249-425-11	CARBON	4. 7K 5% 1/4W	R411	1-249-440-11	CARBON	82K 5% 1/4W
R347	1-249-441-11	CARBON	100K 5% 1/4W	R412	1-247-876-11	CARBON	75K 5% 1/4W
R348	1-249-429-11	CARBON	10K 5% 1/4W	R413	1-249-440-11	CARBON	82K 5% 1/4W
R351	1-249-428-11	CARBON	8. 2K 5% 1/4W	R414	1-247-874-11	CARBON	62K 5% 1/4W
R352	1-249-428-11	CARBON	8. 2K 5% 1/4W	R415	1-249-435-11	CARBON	33K 5% 1/4W
R353	1-249-428-11	CARBON	8. 2K 5% 1/4W	R416	1-247-878-00	CARBON	91K 5% 1/4W
R354	1-249-428-11	CARBON	8. 2K 5% 1/4W	R421	1-249-393-11	CARBON	10 5% 1/4W
R355	1-249-428-11	CARBON	8. 2K 5% 1/4W	R422	1-249-393-11	CARBON	10 5% 1/4W
R356	1-249-428-11	CARBON	8. 2K 5% 1/4W				
R357	1-249-428-11	CARBON	8. 2K 5% 1/4W				

MAIN

DISPLAY

POWER SW

HEADPHONE

TABLE MOTOR

LOADING MOTOR

OPEN/UP SW

Ref. No.	Part No.	Description	Remark		
R425	1-249-429-11	CARBON	10K	5%	1/4W
R426	1-249-429-11	CARBON	10K	5%	1/4W
R427	1-249-429-11	CARBON	10K	5%	1/4W
R428	1-249-429-11	CARBON	10K	5%	1/4W
R429	1-249-429-11	CARBON	10K	5%	1/4W
R430	1-249-429-11	CARBON	10K	5%	1/4W
R431	1-249-429-11	CARBON	10K	5%	1/4W
R432	1-249-429-11	CARBON	10K	5%	1/4W
R450	1-249-435-11	CARBON	33K	5%	1/4W (C215/C315)
R451	1-249-441-11	CARBON	100K	5%	1/4W (C215/C315)
R452	1-249-437-11	CARBON	47K	5%	1/4W (C215/C315)
R453	1-249-405-11	CARBON	100	5%	1/4W (C215/C315)
R460	1-249-435-11	CARBON	33K	5%	1/4W (C215/C315)
R461	1-249-441-11	CARBON	100K	5%	1/4W (C215/C315)
R462	1-249-437-11	CARBON	47K	5%	1/4W (C215/C315)
R463	1-249-405-11	CARBON	100	5%	1/4W (C215/C315)
R501	1-249-422-11	CARBON	2.7K	5%	1/4W
R502	1-249-424-11	CARBON	3.9K	5%	1/4W
R503	1-249-427-11	CARBON	6.8K	5%	1/4W
R504	1-249-432-11	CARBON	18K	5%	1/4W
R505	1-249-422-11	CARBON	2.7K	5%	1/4W
R506	1-249-424-11	CARBON	3.9K	5%	1/4W
R507	1-249-427-11	CARBON	6.8K	5%	1/4W
R508	1-249-432-11	CARBON	18K	5%	1/4W
R509	1-249-422-11	CARBON	2.7K	5%	1/4W
R551	1-249-422-11	CARBON	2.7K	5%	1/4W
R552	1-249-424-11	CARBON	3.9K	5%	1/4W
R553	1-249-427-11	CARBON	6.8K	5%	1/4W
R554	1-249-432-11	CARBON	18K	5%	1/4W
R555	1-249-422-11	CARBON	2.7K	5%	1/4W
R556	1-249-424-11	CARBON	3.9K	5%	1/4W
R557	1-249-427-11	CARBON	6.8K	5%	1/4W
< VARIABLE RESISTOR >					
RV651	1-241-506-11	RES. VAR. CARBON 1K/1K (PHONE LEVEL) (C215/C315)			
< SWITCH >					
S201	△ 1-571-722-11	SWITCH. VOLTAGE SELECTION (E)			
S501	1-554-303-21	SWITCH. TACTILE (▶▶▶)			
S502	1-554-303-21	SWITCH. TACTILE (◀◀◀)			
S503	1-554-303-21	SWITCH. TACTILE (■)			
S504	1-554-303-21	SWITCH. TACTILE (OPEN/CLOSE)			
S505	1-554-303-21	SWITCH. TACTILE (DISC SKIP)			
S506	1-554-303-21	SWITCH. TACTILE (EDIT TIME FADE)			
S507	1-554-303-21	SWITCH. TACTILE (▶▶▶)			
S508	1-554-303-21	SWITCH. TACTILE (◀◀◀)			
S509	1-554-303-21	SWITCH. TACTILE (▷)			

Ref. No.	Part No.	Description	Remark		
S510	1-554-303-21	SWITCH. TACTILE (■)			
S511	1-554-303-21	SWITCH. TACTILE (TIME)			
S512	1-554-303-21	SWITCH. TACTILE (REPEAT)			
S551	1-554-303-21	SWITCH. TACTILE (DISC 1)			
S552	1-554-303-21	SWITCH. TACTILE (DISC 2)			
S553	1-554-303-21	SWITCH. TACTILE (DISC 3)			
S554	1-554-303-21	SWITCH. TACTILE (DISC 4)			
S555	1-554-303-21	SWITCH. TACTILE (DISC 5)			
S556	1-554-303-21	SWITCH. TACTILE (CONTINUE)			
S557	1-554-303-21	SWITCH. TACTILE (SHUFFLE)			
S558	1-554-303-21	SWITCH. TACTILE (PROGRAM)			
S559	1-554-303-21	SWITCH. TACTILE (PEAK SEARCH)			
S560	1-572-714-11	SWITCH. PUSH (POWER ON/OFF)			
< CRYSTAL >					
X351	1-567-965-11	VIBRATOR, CRYSTAL (22.5MHz)			

* 1-638-729-11 TABLE MOTOR BOARD					

* 1-638-730-11 LOADING MOTOR BOARD					

* 1-638-731-11 OPEN/UP SW BOARD					

< CAPACITOR >					
C704	1-161-375-00	CERAMIC	0.0022uF	20%	50V
C705	1-161-375-00	CERAMIC	0.0022uF	20%	50V
< CONNECTOR >					
CN705	* 1-566-214-11	PIN. CONNECTOR (PC BOARD) 2P			
CN707	* 1-573-044-11	SOCKET, CONNECTOR			
< DIODE >					
D701	8-719-970-19	DIODE GP1A521			
< RESISTOR >					
R701	1-249-416-11	CARBON	820	5%	1/4W
< SWITCH >					
S702	1-571-300-21	SWITCH. ROTARY (OPEN/UP)			

Note:
The components identified by mark △ or dotted line with mark △ are critical for safety. Replace only with part number specified.

Note:
Les composants identifiés par une marque △ sont critiques pour la sécurité. Ne les remplacer que par une pièce portant le numéro spécifié.

Ref. No.	Part No.	Description	Remark
		MISCELLANEOUS *****	
6	1-590-835-11	WIRE, FLAT TYPE (34 CORE)	
54	1-452-340-21	MAGNET	
63	1-590-849-11	WIRE, FLAT TYPE (5 CORE)	
101	1-535-892-11	JUMPER, FILM (WITH TERMINAL)	
124	△ 1-558-946-21	CORD, POWER (UK)	
124	△ 1-574-358-31	CORD, POWER (WITH CONNECTOR) (Australian)	
124	△ 1-575-651-21	CORD, POWER (AEP)	
124	△ 1-575-653-21	CORD, POWER (E)	
124	△ 1-590-836-11	CORD, POWER (US, Canadian)	
125	△ 1-569-007-11	ADAPTOR, CONVERSION 2P (E)	
151	△ 8-848-144-11	DEVICE, OPTICAL KSS-240A	
152	1-575-001-11	WIRE, FLAT TYPE (12 CORE)	
M101	X-4917-523-3	BASE (OUTSERT) ASSY (SPINDLE MOTOR)	
M102	X-4917-504-1	MOTOR ASSY (SLED)	
M701	A-4604-585-A	MOTOR ASSY, ROTARY (TABLE)	
M702	A-4604-834-A	MOTOR ASSY, LOADING	
S701	1-572-713-11	SWITCH, PUSH (WITH CONNECTOR) (DOWN)	
T901	△ 1-449-954-11	TRANSFORMER, POWER (US, Canadian)	
T901	△ 1-449-955-11	TRANSFORMER, POWER (AEP, UK, Australian)	
T901	△ 1-449-956-11	TRANSFORMER, POWER (E)	

ACCESSORY & PACKING MATERIAL

- 1-465-733-11 REMOTE COMMANDER (C315)
- 1-559-533-11 CORD, CONNECTION
- 2-181-754-01 COVER, BATTERY (C315)
- 3-753-144-11 MANUAL, INSTRUCTION (ENGLISH, FRENCH, SPANISH, PORTUGUESE) (AEP, UK, E)
- 3-753-144-21 MANUAL, INSTRUCTION (ENGLISH) (US, Canadian, Australian)
- 3-753-144-31 MANUAL, INSTRUCTION (FRENCH) (Canadian)
- 3-753-144-41 MANUAL, INSTRUCTION (GERMAN, DUTCH, SWEDISH, ITALIAN) (AEP)
- 4-937-945-01 PLATE (TRANSPORT), LOCK
- * 4-941-548-01 LABEL, CLASS 1 (AEP, UK, E, Australian)
- * 4-944-109-01 INDIVIDUAL CARTON (C315)
- * 4-944-109-11 INDIVIDUAL CARTON (C215)
- * 4-944-109-21 INDIVIDUAL CARTON (C211)
- * 4-944-110-01 CUSHION (FRONT)
- * 4-944-111-01 CUSHION (REAR)

Ref. No.	Part No.	Description	Remark
		HARDWARE LIST *****	
# 1	7-685-647-79	SCREW +BVTP 3X10 TYPE2 N-S	
# 2	7-682-548-04	SCREW +BVTT 3X8 (S)	
# 3	7-682-547-04	SCREW +BVTT 3X6 (S)	
# 4	7-685-648-79	SCREW +BVTP 3X12 TYPE2 N-S (C215/C315)	
# 5	7-682-554-04	SCREW +B 3X25	
# 6	7-685-648-79	SCREW (M3X12), TAPPING	
# 7	7-685-136-19	SCREW +P 2.6X12 TYPE2 NON-SLIT	
# 8	7-685-647-79	SCREW, TAPPING	
# 9	7-621-255-15	SCREW +P 2X3	
#10	7-685-134-19	SCREW +BTP 2.6X8 TYPE2 N-S	

Note:
The components identified by mark △ or dotted line with mark △ are critical for safety. Replace only with part number specified.

Note:
Les composants identifiés par une marque △ sont critiques pour la sécurité. Ne les remplacer que par une pièce portant le numéro spécifié.