

CDP-C160Z/C260Z/CE215/CE315

SERVICE MANUAL



Photo : CDP-CE315

US Model
CDP-C160Z/C260Z/CE215/CE315

Canadian Model
CDP-C260Z/CE215/CE315

AEP Model
Australian Model
CDP-CE215/CE315

UK Model
E Model
CDP-CE315

Model Name Using Similar Mechanism	CDP-C250Z/C350Z/CE305/CE405
CD Mechanism Type	CDM27A2-5BD20
Base Unit Type	BU-5BD20
Optical Pick-up Type	KSS-213BA/F-NP

SPECIFICATIONS

Compact Disc Player

Laser	Semiconductor laser ($\lambda = 780 \text{ nm}$)
Laser output	Emission duration: continuous Max 44.6 μW * * This output is the value measured at a distance of 200 mm from the objective lens surface on the Optical Pick-up block with 7 mm aperture.
Frequency response	2 Hz to 20 kHz $\pm 0.5 \text{ dB}$
Signal-to-noise ratio	More than 102 dB
Dynamic range	More than 98 dB
Harmonic distortion	Less than 0.0045%

Output

	Jack type	Maximum output level	Load impedance
LINE OUT	Phono jacks	2V (at 50 kilohms)	Over 10 kilohms
DIGITAL OUT (OPTICAL) (AEP, UK, CIS, North European, East European models only)	Optical output connector	-18 dBm	Wave length: 660nm

General

Power requirements

Where purchased	Power requirements
US, Canadian	120V AC, 60 Hz
AEP, UK, CIS, Singapore North European, East European	220-230V AC, 50/60 Hz
Australian	240V AC, 50/60 Hz
E	110-120V, 220-240V adjustable, 50/60 Hz

Power consumption	14W
Dimensions (approx.) (w/h/d)	430 \times 120 \times 385 mm (17 \times 4 3/4 \times 15 1/4 in.) incl. projecting parts
Mass (approx.)	5.4 kg (11 lbs 15 oz)

Supplied accessories

Audio cord (2 phono plugs-2 phono plugs) (1)
Remote commander (remote) (CDP-CE315 and CDP-C260Z only)
Sony SUM-3 (NS) batteries (2) (CDP-CE315 and CDP-C260Z only)

Design and specifications are subject to change without notice.

COMPACT DISC PLAYER



SONY®

The following caution label is located inside of the unit.

CAUTION	; INVISIBLE LASER RADIATION WHEN OPEN. AVOID EXPOSURE TO BEAM.
ADVARSEL	; USYNLIG LASERSTRÅLING VED ÅBNING NÅR SIKKERHEDSÅRBEYDERE ER UDE AF FUNKTION. UNDGÅ UDSÆTTELSE FOR STRÅLING.
VARO!	; AVATTAESSA JA SUOJALUKITUS OHITETTAESSA DLET ALTIINA LASERSÄTELYLLE.
VARNING	; LASERSTRÅLING NÅR DENNA DEL ÄR ÖPPNAD OCH SPÄRREN ÄR URÖPPPLAD.
ADVARSEL	; USYNLIG LASERSTRÅLING NÅR DEKSEL ÅPNES UNNGÅ EKSPONERING FOR STRÅLEN.

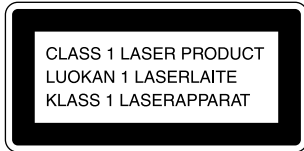

This appliance is classified as a CLASS 1 LASER product.
The CLASS 1 LASER PRODUCT MARKING is located on the rear exterior.

CAUTION
Use of controls or adjustments or performance of procedures other than those specified herein may result in hazardous radiation exposure.

TABLE OF CONTENTS

1. GENERAL	5
2. DISASSEMBLY	
2-1. Case, Bottom Plate and Front Panel	6
2-2. Back Panel and Disc Table	6
2-3. Optical Pick-up Block Assembly	7
2-4. Bracket (Gear) Assembly	7
3. ELECTRICAL BLOCK CHECKING	8
4. DIAGRAMS	
4-1. Circuit Boards Location	10
4-2. Printed Wiring Board — BD Section —	11
4-3. Schematic Diagram — BD Section —	13
4-4. Printed Wiring Board — Main Section —	15
4-5. Schematic Diagram — Main Section —	17
4-6. Schematic Diagram — Display Section —	19
4-7. Printed Wiring Board — Display Section —	21
4-8. IC Block Diagrams	23
4-9. IC Pin Functions	
• IC101 Digital Signal Processor (CXD2545Q)	25
• IC302 System Control (CXP82324-082Q)	28
5. EXPLODED VIEWS	
5-1. Front Panel and Case Section	30
5-2. Back Panel and Disc Table Section	31
5-3. Chassis Section	32
5-4. Base Unit Section (BU-5BD20)	33
6. ELECTRICAL PARTS LIST	34

SAFETY-RELATED COMPONENT WARNING!!

COMPONENTS IDENTIFIED BY MARK \triangle OR DOTTED LINE WITH MARK \triangle ON THE SCHEMATIC DIAGRAMS AND IN THE PARTS LIST ARE CRITICAL TO SAFE OPERATION. REPLACE THESE COMPONENTS WITH SONY PARTS WHOSE PART NUMBERS APPEAR AS SHOWN IN THIS MANUAL OR IN SUPPLEMENTS PUBLISHED BY SONY.

ATTENTION AU COMPOSANT AYANT RAPPORT À LA SÉCURITÉ!

LES COMPOSANTS IDENTIFIÉS PAR UNE MARQUE \triangle SUR LES DIAGRAMMES SCHÉMATIQUES ET LA LISTE DES PIÈCES SONT CRITIQUES POUR LA SÉCURITÉ DE FONCTIONNEMENT. NE REMPLACER CES COMPOSANTS QUE PAR DES PIÈCES SONY DONT LES NUMÉROS SONT DONNÉS DANS CE MANUEL OU DANS LES SUPPLÉMENTS PUBLIÉS PAR SONY.

MODEL IDENTIFICATION
— BACK PANEL —

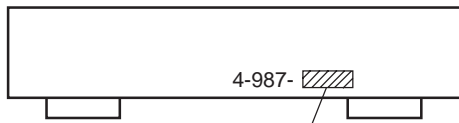

CDP-C160Z	
US Model	: 782-4□
CDP-C260Z	
US Model	: 783-7□
Canadian Model	: 783-8□
CDP-CE215	
US Model	: 782-0□
Canadian Model	: 782-1□
AEP Model	: 782-2□
Australian Model	: 782-3□
CDP-CE315	
AEP, East European, North European,	
CIS Model	: 783-0□
UK Model	: 783-1□
Singapore Model	: 783-2□
Australian Model	: 783-3□
E Model	: 783-4□
US Model	: 783-5□
Canadian Model	: 783-6□

**NOTES ON HANDLING THE OPTICAL PICK-UP
BLOCK OR BASE UNIT**

The laser diode in the optical pick-up block may suffer electrostatic breakdown because of the potential difference generated by the charged electrostatic load, etc. on clothing and the human body. During repair, pay attention to electrostatic breakdown and also use the procedure in the printed matter which is included in the repair parts. The flexible board is easily damaged and should be handled with care.

NOTES ON LASER DIODE EMISSION CHECK

The laser beam on this model is concentrated so as to be focused on the disc reflective surface by the objective lens in the optical pick-up block. Therefore, when checking the laser diode emission, observe from more than 30 cm away from the objective lens.

SAFETY CHECK-OUT
(US model only)

After correcting the original service problem, perform the following safety checks before releasing the set to the customer: Check the antenna terminals, metal trim, “metallized” knobs, screws, and all other exposed metal parts for AC leakage. Check leakage as described below.

LEAKAGE

The AC leakage from any exposed metal part to earth ground and from all exposed metal parts to any exposed metal part having a return to chassis, must not exceed 0.5 mA (500 microamperes). Leakage current can be measured by any one of three methods.

1. A commercial leakage tester, such as the Simpson 229 or RCA WT-540A. Follow the manufacturers’ instructions to use these instruments.
2. A battery-operated AC milliammeter. The Data Precision 245 digital multimeter is suitable for this job.
3. Measuring the voltage drop across a resistor by means of a VOM or battery-operated AC voltmeter. The “limit” indication is 0.75 V, so analog meters must have an accurate low-voltage scale. The Simpson 250 and Sanwa SH-63Trd are examples of a passive VOM that is suitable. Nearly all battery operated digital multimeters that have a 2V AC range are suitable. (See Fig. A)

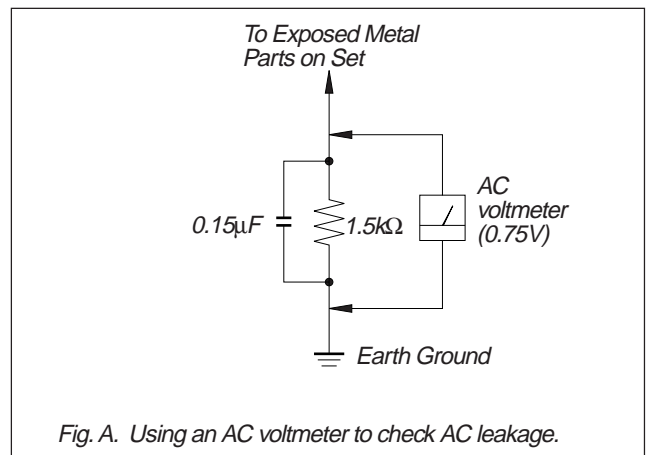
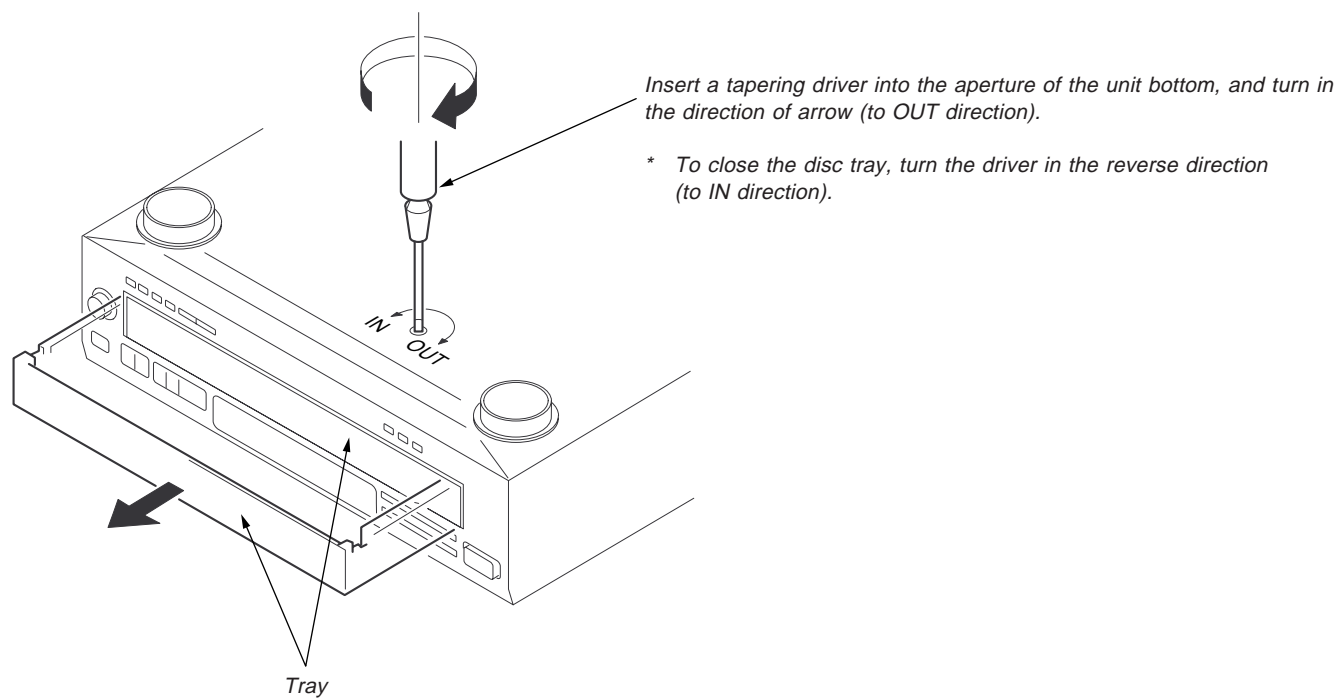
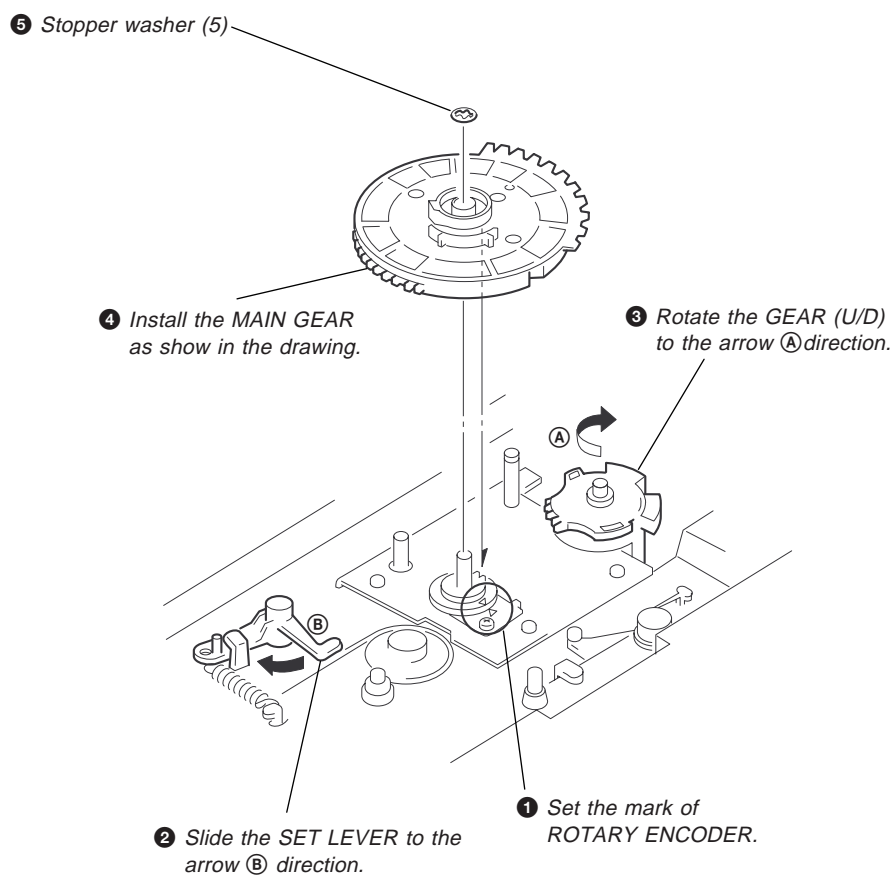

Fig. A. Using an AC voltmeter to check AC leakage.

HOW TO OPEN THE DISC TRAY WHEN POWER SWITCH TURNS OFF



NOTE FOR MAIN GEAR INSTALLATION



SECTION 1 GENERAL

Identifying the Parts

Front Panel

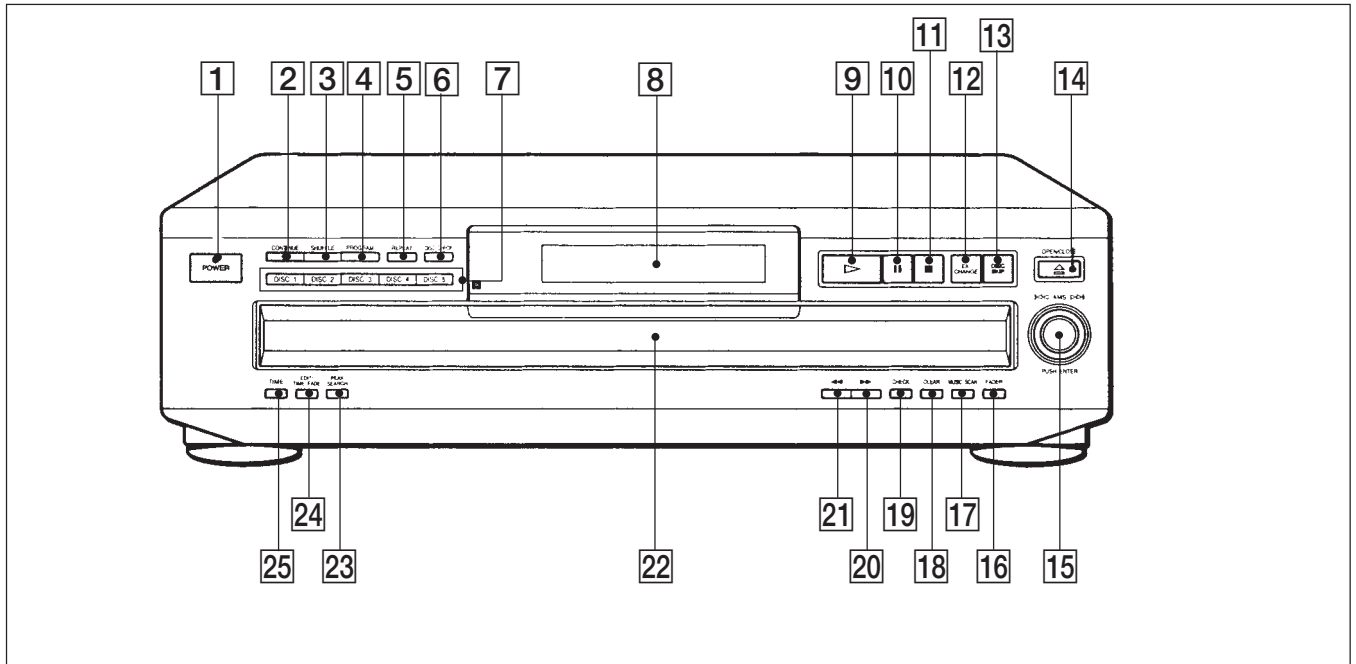

- | | |
|---|--|
| 1 POWER switch | 13 DISC SKIP button |
| 2 CONTINUE button | 14 ▲ OPEN/CLOSE button |
| 3 SHUFFLE button | 15 AMS knob |
| 4 PROGRAM button | 16 FADER button |
| 5 REPEAT button | 17 MUSIC SCAN button |
| 6 DISC CHECK button: CE215/CE315 model
TIME button: C160Z/C260Z model | 18 CLEAR button |
| 7 DISC 1-5 button | 19 CHECK button |
| 8 Display window | 20 ►► (forward) button |
| 9 ► (play) button | 21 ◀◀ (backward) button |
| 10 ■■ (pause) button | 22 Disc tray |
| 11 ■ (stop) button | 23 PEAK SEARCH button: CE215/CE315 model |
| 12 EX-CHANGE button | 24 EDIT/TIME FADE button: CE215/CE315 model |
| | 25 TIME button: CE215/CE315 model |

SECTION 2 DISASSEMBLY

Note : Follow the disassembly procedure in the numerical order given.

2-1. CASE, BOTTOM PLATE AND FRONT PANEL

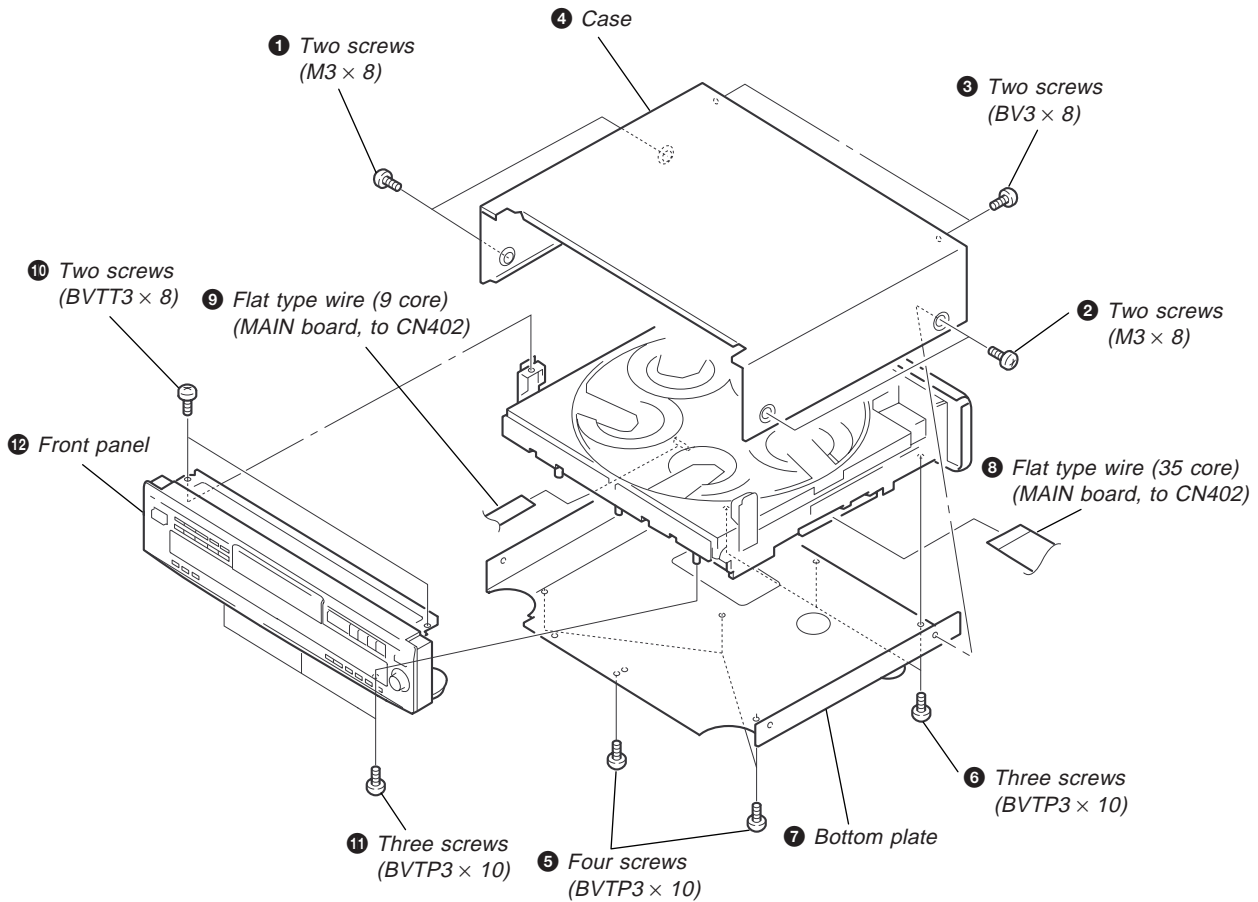

2-2. BACK PANEL AND DISC TABLE

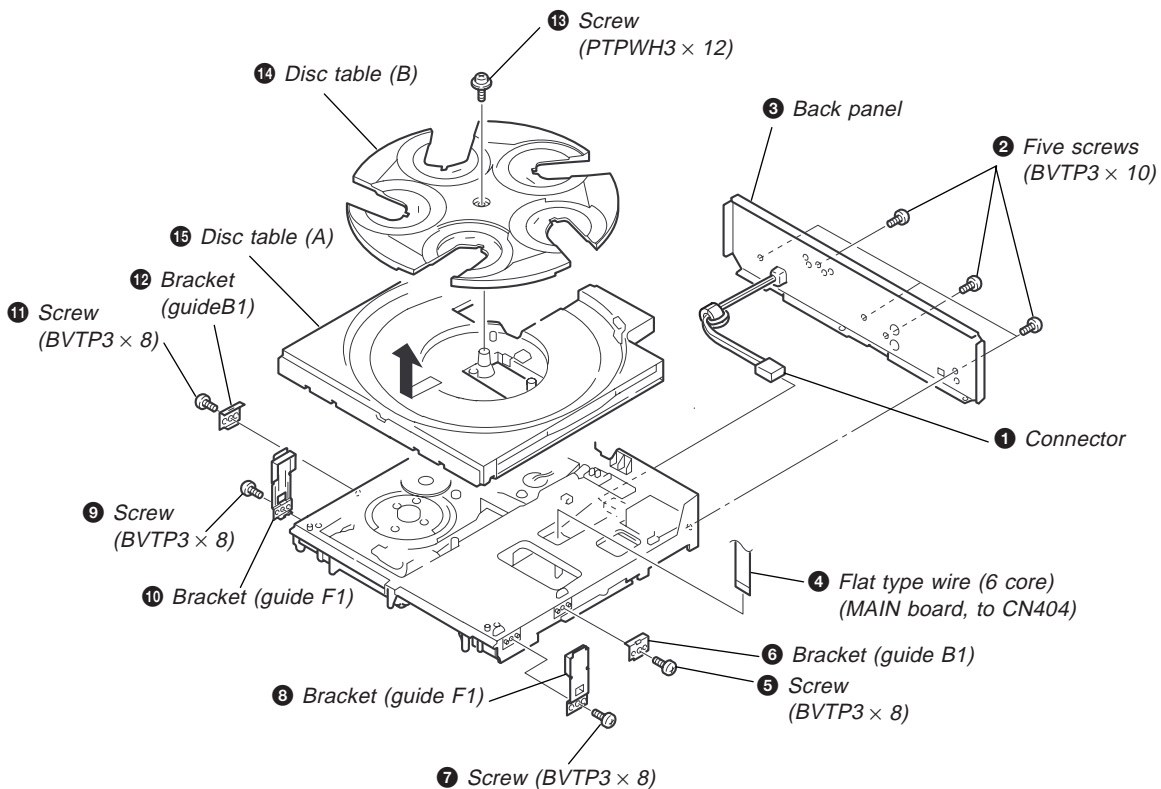

2-3. OPTICAL PICK-UP BLOCK ASSEMBLY

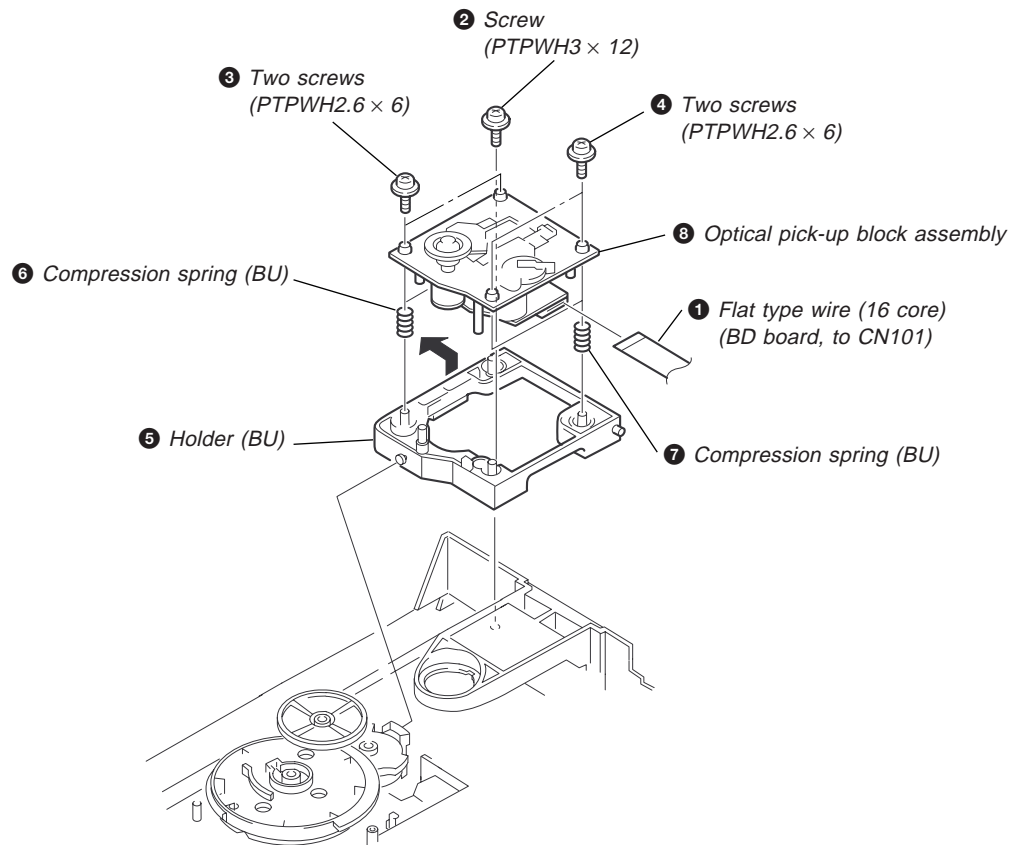

2-4. BRACKET (GEAR) ASSEMBLY

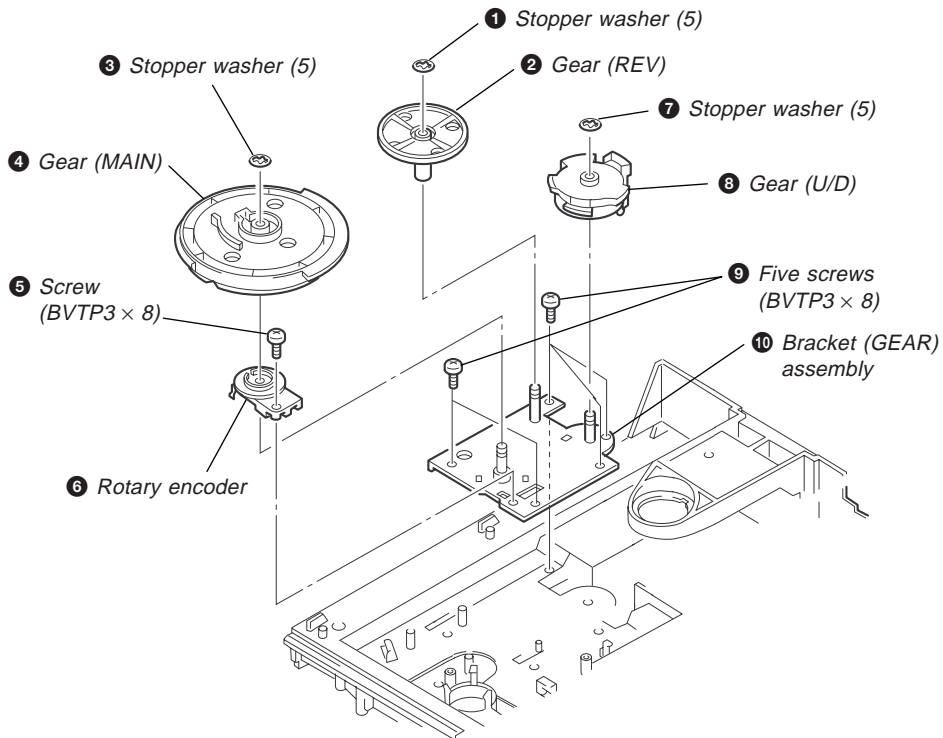

Note : As for the installation of the main gear, refer to “Note for MAIN GEAR installation” on page 4.

SECTION 3 ELECTRICAL BLOCK CHECKING

Note :

1. CD Block is basically designed to operate without adjustment. Therefore, check each item in order given.
2. Use YEDS-18 disc (3-702-101-01) unless otherwise indicated.
3. Use an oscilloscope with more than 10MΩ impedance.
4. Clean the object lens using an applicator with neutral detergent when the signal level is low than specified value with the following checks.

S Curve Check

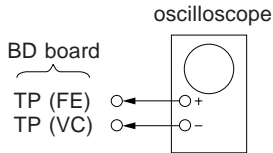

Procedure :

1. Connect oscilloscope to test point TP (FE) on BD board.
2. Connect between test point TP (FEI) and TP (VC) by lead wire.
3. Turn Power switch on.
4. Put disc (YEDS-18) in and turn Power switch on again and actuate the focus search. (Actuate the focus search when disc table is moving in and out.)
5. Check if the oscilloscope waveform (S-curve) is symmetrical between A and B. And confirm peak to peak level within 3 ± 1 Vp-p.

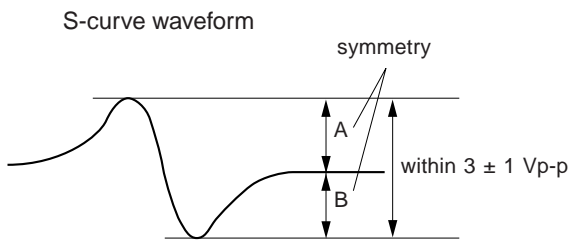

6. After check, remove the lead wire connected in step 2.
- Note :
- Try to measure several times to make sure than the ratio of A : B or B : A is more than 10 : 7.
 - Take sweep time as long as possible and light up the brightness to obtain best waveform.

RF Level Check

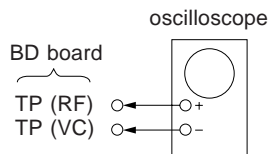

Procedure :

1. Connect oscilloscope to test point TP (RF) on BD board.
2. Turned Power switch on.
3. Put disc (YEDS-18) in to play the number five track.
4. Confirm that oscilloscope waveform is clear and check if RF signal level is correct or not.

Note :

A clear RF signal waveform means that the shape “◇” can be clearly distinguished at the center of the waveform.

RF signal waveform

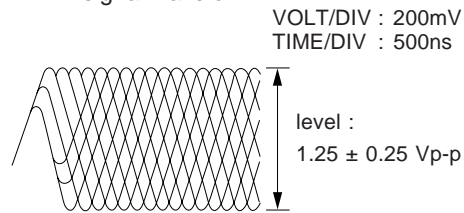

E-F Balance Check

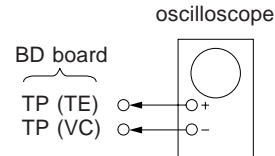

Procedure :

1. Connect test point TP1 (ADJ) to ground with a lead wire.
2. Connect oscilloscope to test point TP (TE) on BD board.
3. Turned Power switch on.
4. Put disc (YEDS-18) in to play the number five track.
5. Press the “3” button. (The tracking servo and the sledding servo are turned OFF.)
6. Check the level B of the oscilloscope's waveform and the A (DC voltage) of the center of the Traverse waveform. Confirm the following : $A/B \times 100 = \text{less than } \pm 22\%$

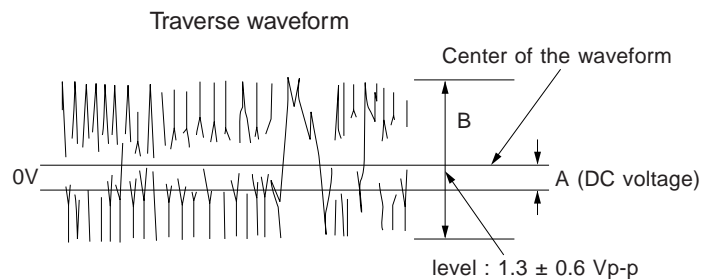

7. Press the “8” button. (The tracking servo and sledding servo are turned ON.) Confirm the C (DC voltage) is almost equal to the A (DC voltage) is step 6.

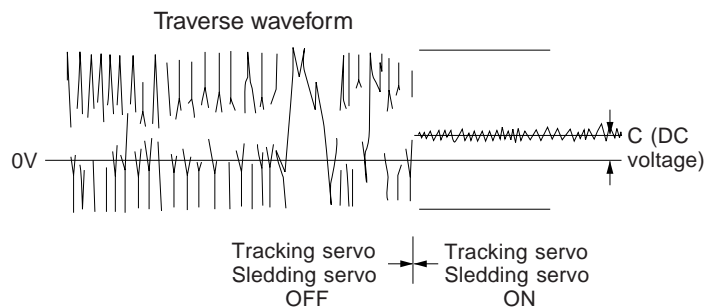

8. Disconnect the lead wire of TP (ADJ) connected in step 1.

SECTION 4 DIAGRAMS

RF PLL Free-run Frequency Check

Procedure :

1. Connect frequency counter to test point (PLCK) with lead wire.

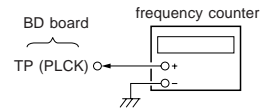

2. Turned Power switch on.
3. Put the disc (YEDS-18) in to play the number five track. Confirm that reading on frequency counter is 4.3218MHz.

Adjustment Location :

[BD BOARD] — Conductor Side —

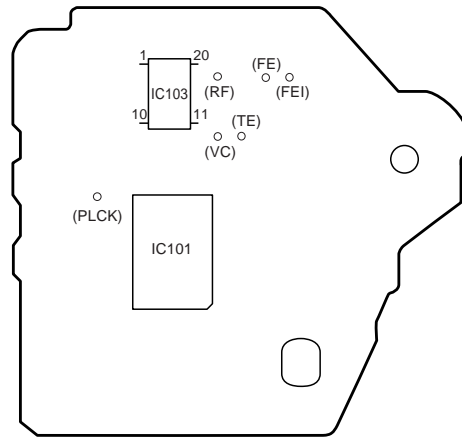

[MAIN BOARD] — Conductor Side —

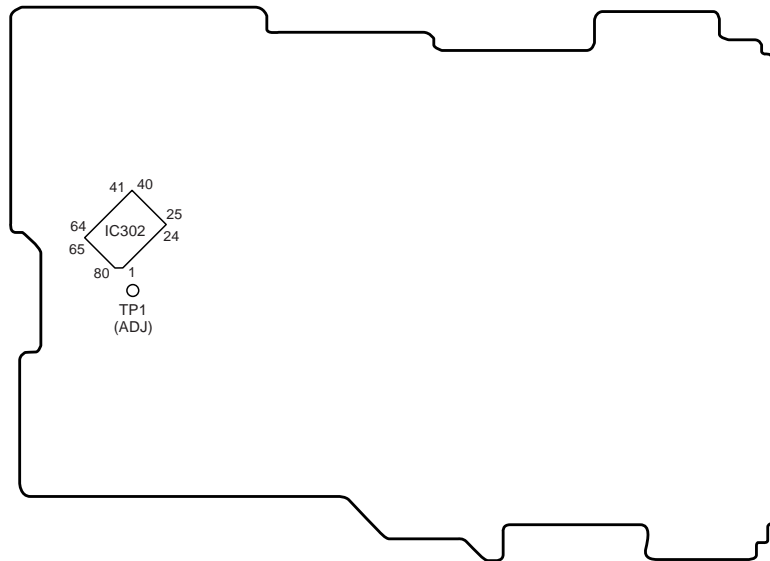

4-1. CIRCUIT BOARDS LOCATION

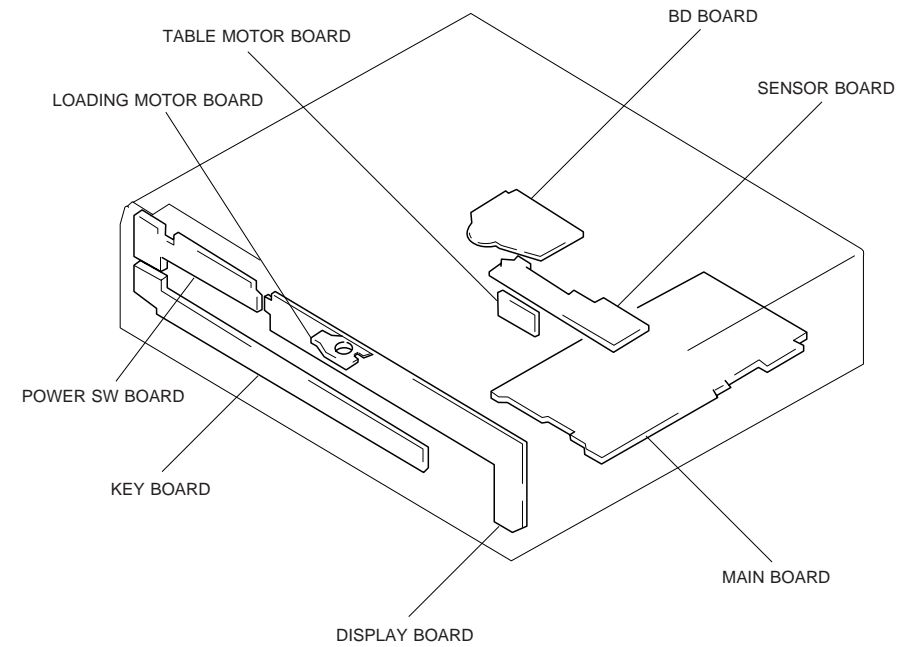

4-2. PRINTED WIRING BOARD - BD SECTION -

• See page 10 for Circuit Board Location.

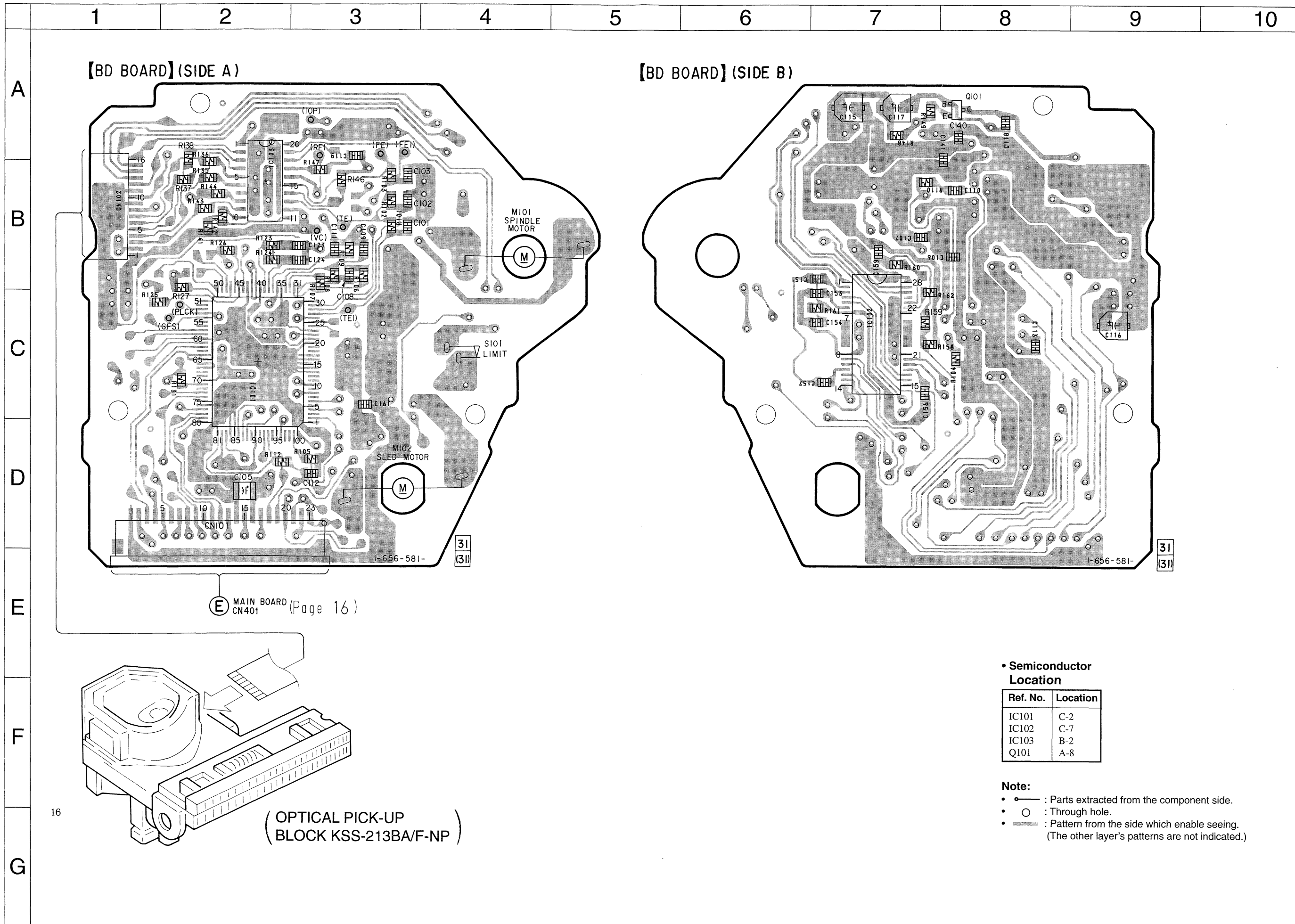

4-3. SCHEMATIC DIAGRAM – BD SECTION –

- See page 23 for IC Block Diagrams.
- See page 25 for IC Pin Functions. (IC101)

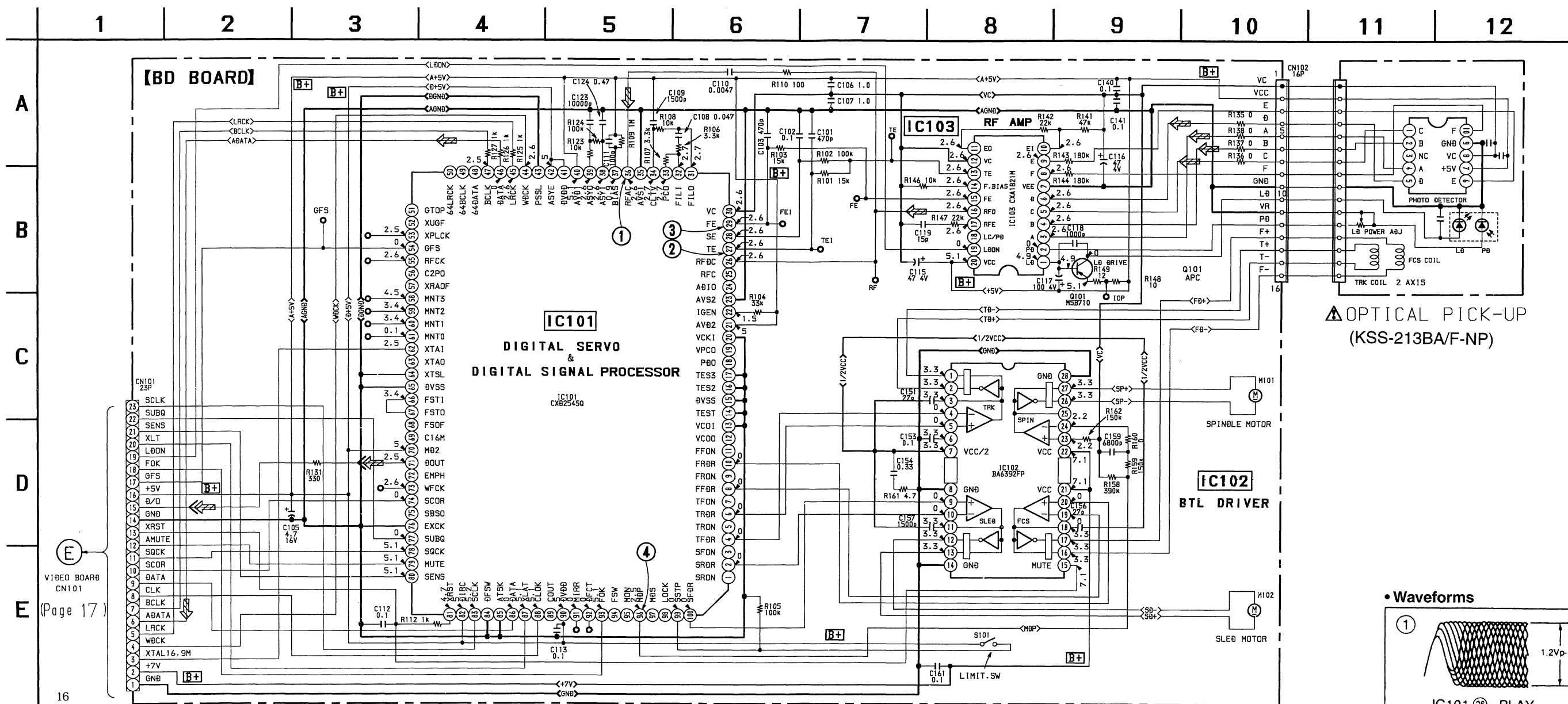

Note:

- All capacitors are in μF unless otherwise noted. pF: μF 50WV or less are not indicated except for electrolytics and tantalums.
- All resistors are in Ω and 1/4W or less unless otherwise specified.
- **B+**: B+ Line.
- Voltages and waveforms are dc with respect to ground under no-signal conditions.
- No mark: STOP
- Voltages are taken with a VOM (Input impedance 10M Ω). Voltage variations may be noted due to normal production tolerances.
- Waveforms are taken with an oscilloscope. Voltage variations may be noted due to normal production tolerances.

- Circled numbers refer to waveforms.
- Signal path.
 - \Rightarrow : CD
 - \Rightarrow : Digital out

<p>Note : The components identified by mark Δ or dotted line with mark Δ are critical for safety. Replace only with part number specified.</p>	<p>Note : Les composants identifiés par une marque Δ sont critiques pour la sécurité. Ne les remplacer que par une pièce portant le numéro spécifié.</p>
---	---

• Waveforms

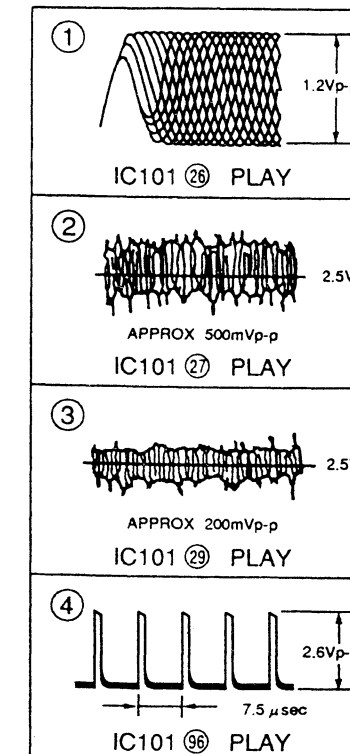

CDP-C160Z/C260Z/CE215/CE315

4-4. PRINTED WIRING BOARD - MAIN SECTION -

• See page 10 for Circuit Board Location.

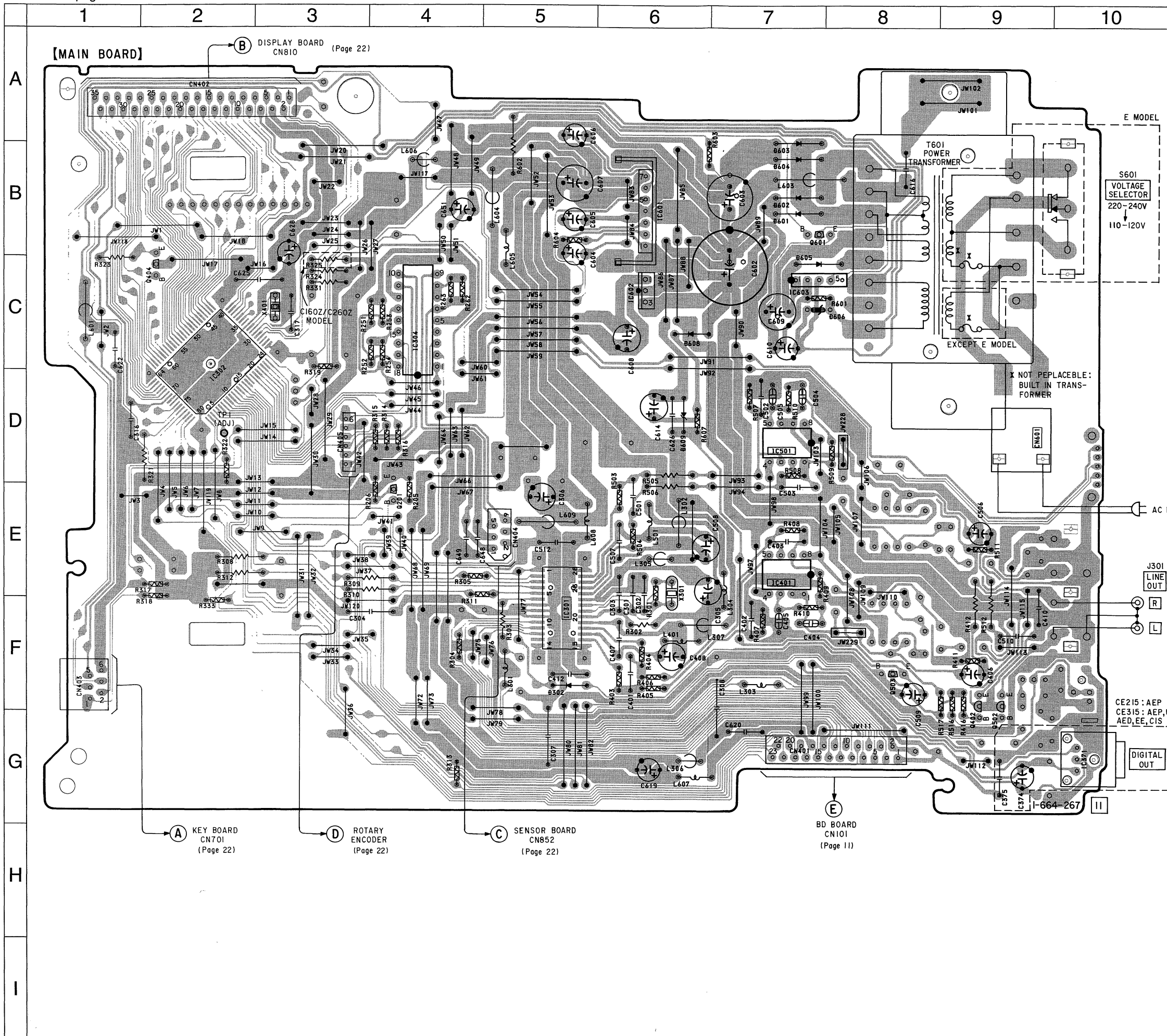

• Semiconductor Location

Ref. No.	Location
D302	F-5
D601	B-7
D602	B-7
D603	A-7
D604	B-7
D605	B-7
D606	C-8
D608	C-6
D609	D-6
IC301	F-5
IC302	D-2
IC304	C-4
IC371	G-10
IC401	E-7
IC501	D-7
IC601	B-6
IC602	C-6
IC603	C-7
Q201	E-4
Q402	F-9
Q404	C-2
Q502	F-9
Q503	F-8
Q601	B-7

• Waveforms

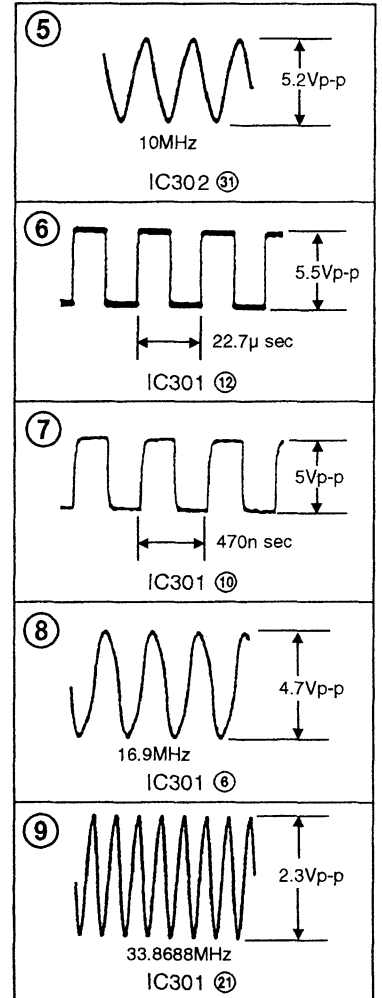

Note:

- : Parts extracted from the component side.
 - Δ : Internal component.
 - — : Pattern from the side which enable seeing.
- Abbreviation
 AED: North European
 EE: East European

4-5. SCHEMATIC DIAGRAM – MAIN SECTION –

- See page 23 for IC Block Diagrams.
- See page 28 for IC Pin Function. (IC302)

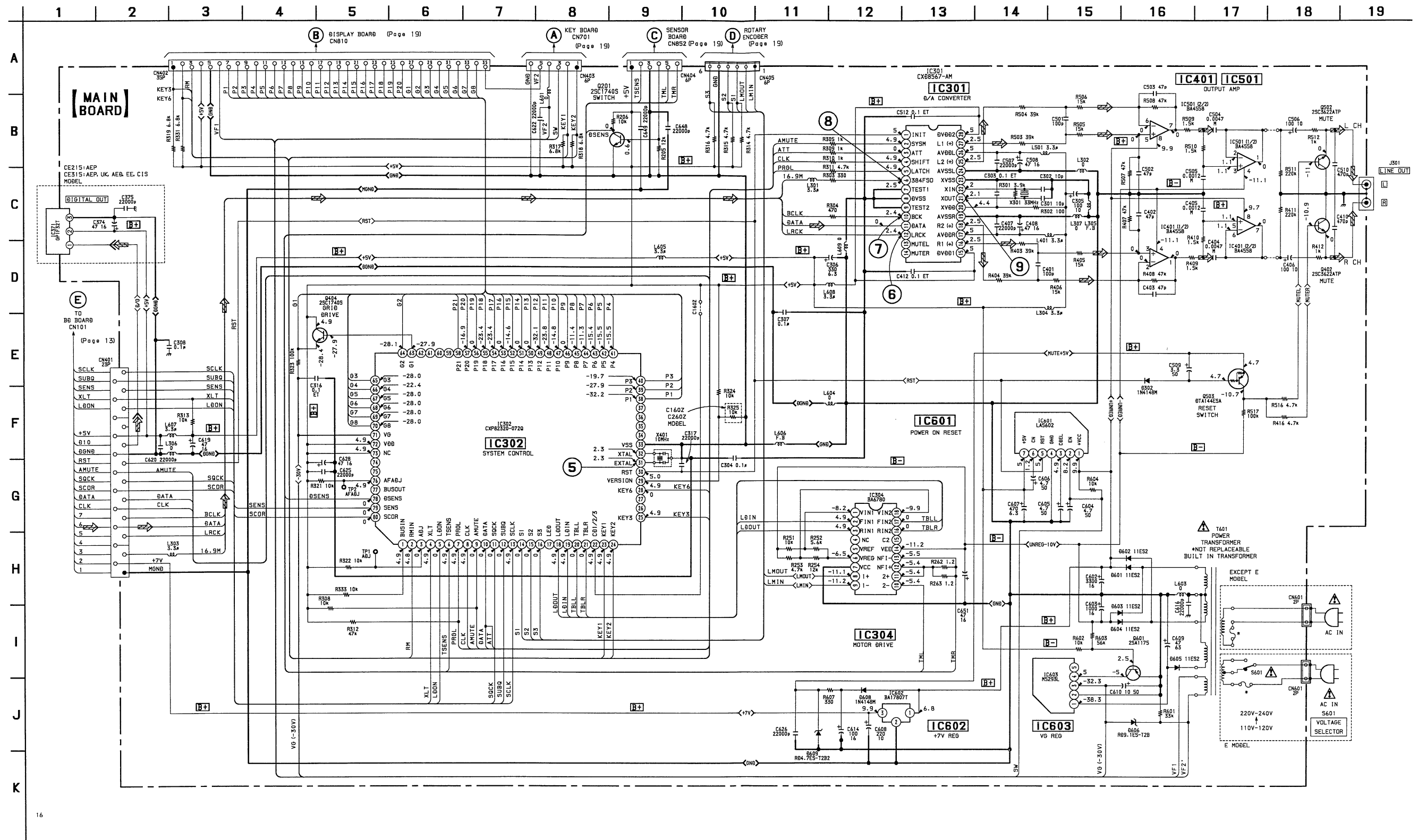

Note:

- All capacitors are in μF unless otherwise noted. pF: μF 50WV or less are not indicated except for electrolytics and tantalums.
- All resistors are in Ω and 1/4W or less unless otherwise specified.
- Δ : Internal component.
- \square : Panel designation.
- **B+**: B+ Line.
- **B-**: B- Line.
- Voltages and waveforms are dc with respect to ground under no-signal conditions.

- No mark: STOP
- Voltages are taken with a VOM (Input impedance 10M Ω). Voltage variations may be noted due to normal production tolerances.
- Waveforms are taken with an oscilloscope. Voltage variations may be noted due to normal production tolerances.
- Circled numbers refer to waveforms.

- Signal path. \Rightarrow : CD \Rightarrow : Digital out
- Abbreviation
AED: North European
EE: East European

Note:
The components identified by mark Δ or dotted line with mark Δ are critical for safety. Replace only with part number specified.

Note:
Les composants identifiés par une marque Δ sont critiques pour la sécurité. Ne les remplacer que par une pièce portant le numéro spécifique.

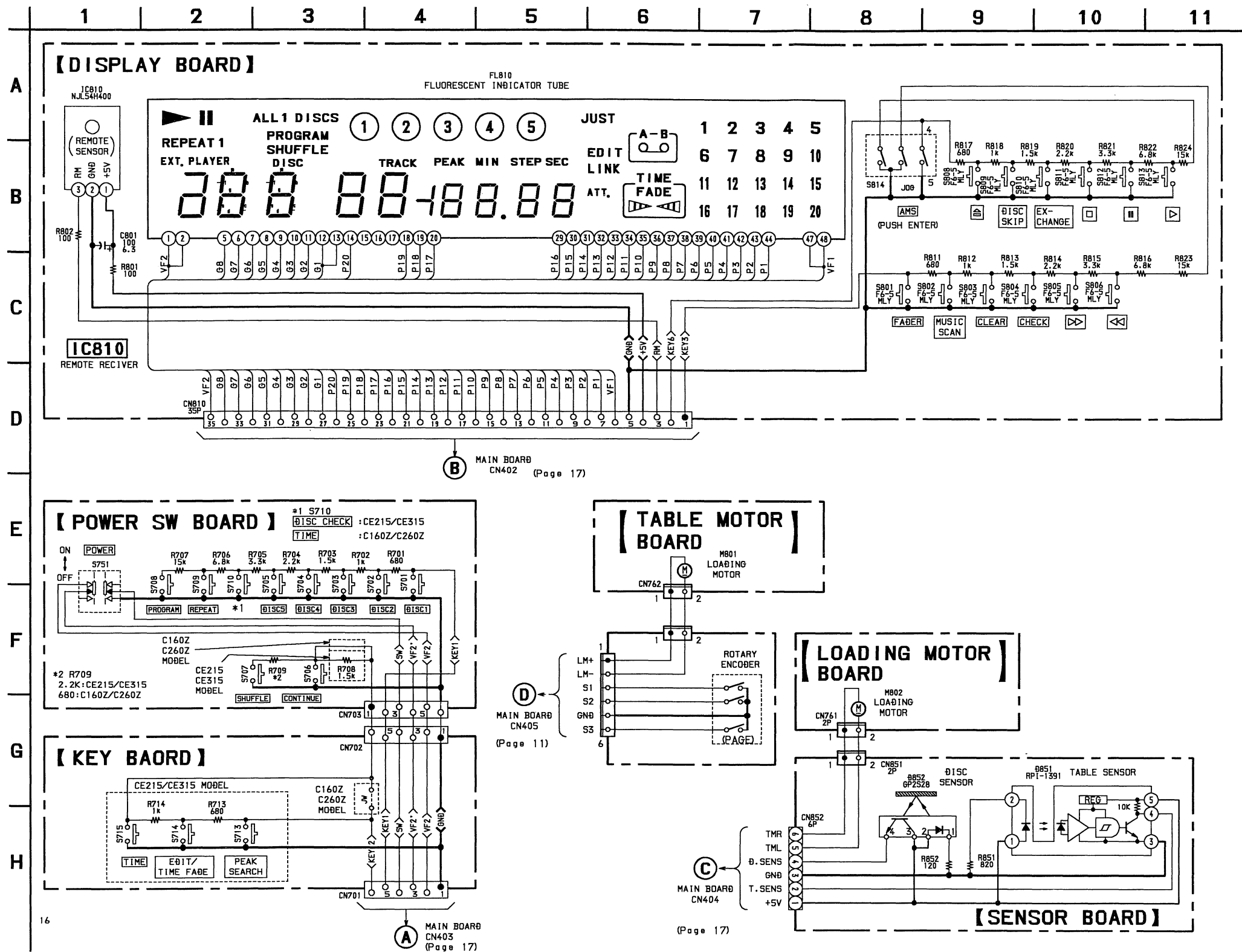

Note:

- All capacitors are in μF unless otherwise noted. pF: μF 50WV or less are not indicated except for electrolytics and tantalums.
- All resistors are in Ω and 1/4W or less unless otherwise specified.
- \triangle : Internal component.
- \square : Panel designation.
- $\text{B}+$: B+ Line.
- $\text{B}-$: B- Line.
- Voltages and waveforms are dc with respect to ground under no-signal conditions. No mark: STOP
- Voltages are taken with a VOM (Input impedance 10M Ω). Voltage variations may be noted due to normal production tolerances.
- Waveforms are taken with an oscilloscope. Voltage variations may be noted due to normal production tolerances.
- Circled numbers refer to waveforms.

<p>Note:</p> <p>The components identified by mark \triangle or dotted line with mark \triangle are critical for safety. Replace only with part number specified.</p>	<p>Note:</p> <p>Les composants identifiés par une marque \triangle sont critiques pour la sécurité. Ne les remplacer que par une pièce portant le numéro spécifié.</p>
---	--

4-7. PRINTED WIRING BOARD – DISPLAY SECTION –

• See page 10 for Circuit Board Location.

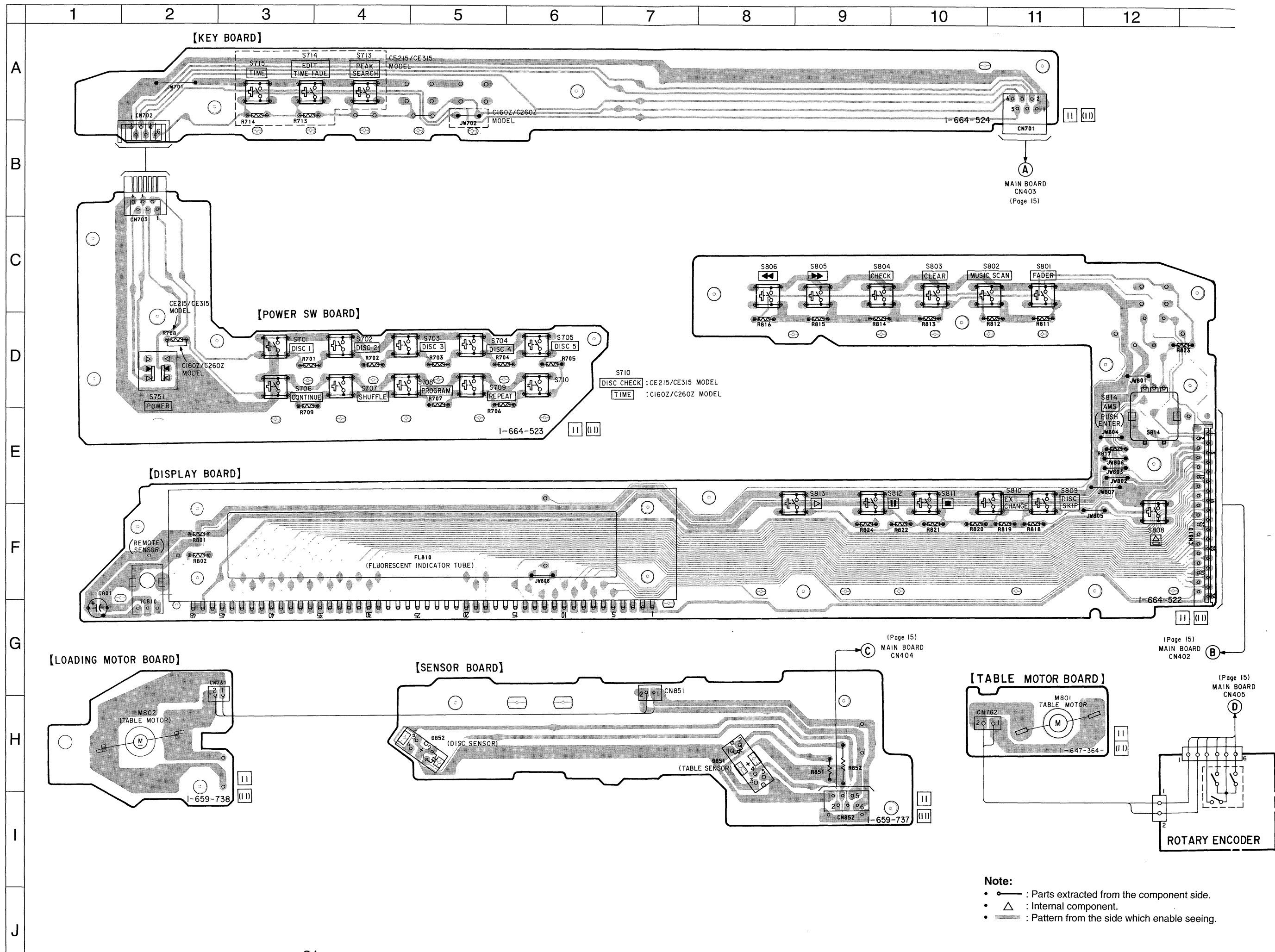

Note:
 • — : Parts extracted from the component side.
 • Δ : Internal component.
 • — : Pattern from the side which enable seeing.

4-8. IC BLOCK DIAGRAMS

IC101 CXA2545Q

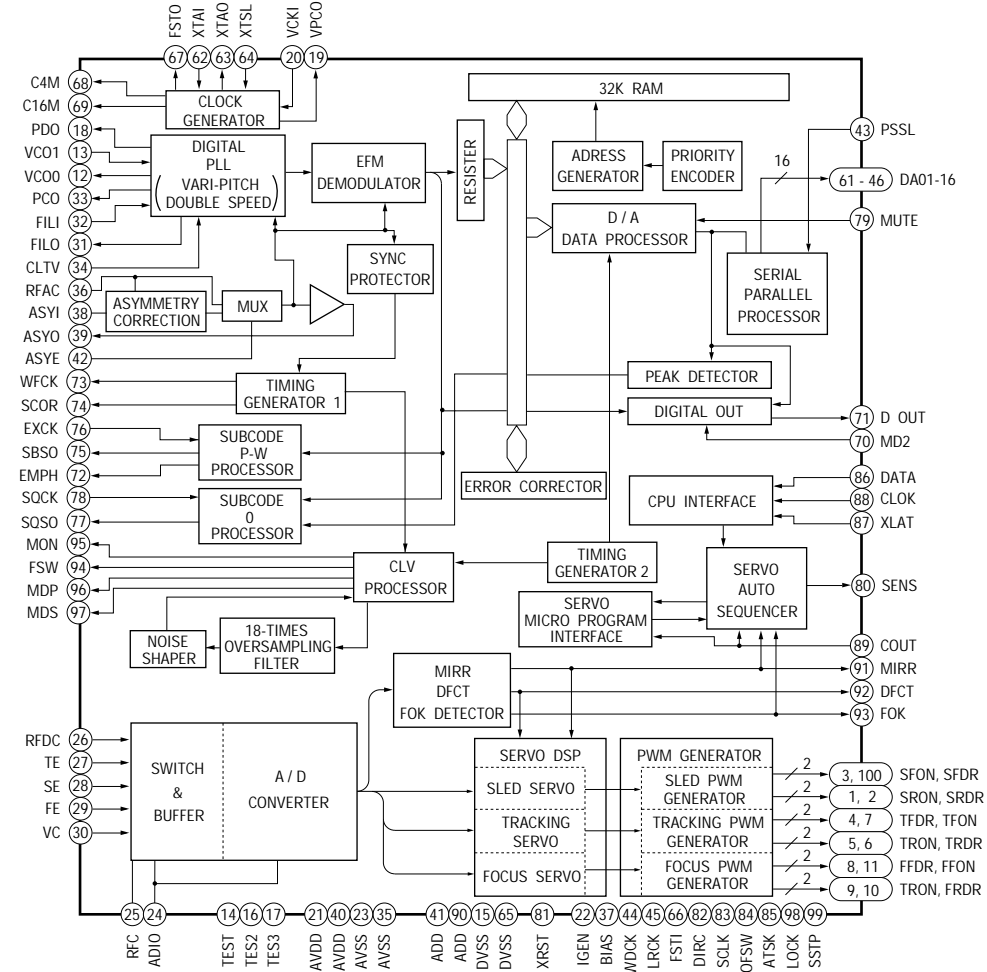

IC301 CXD8567AM

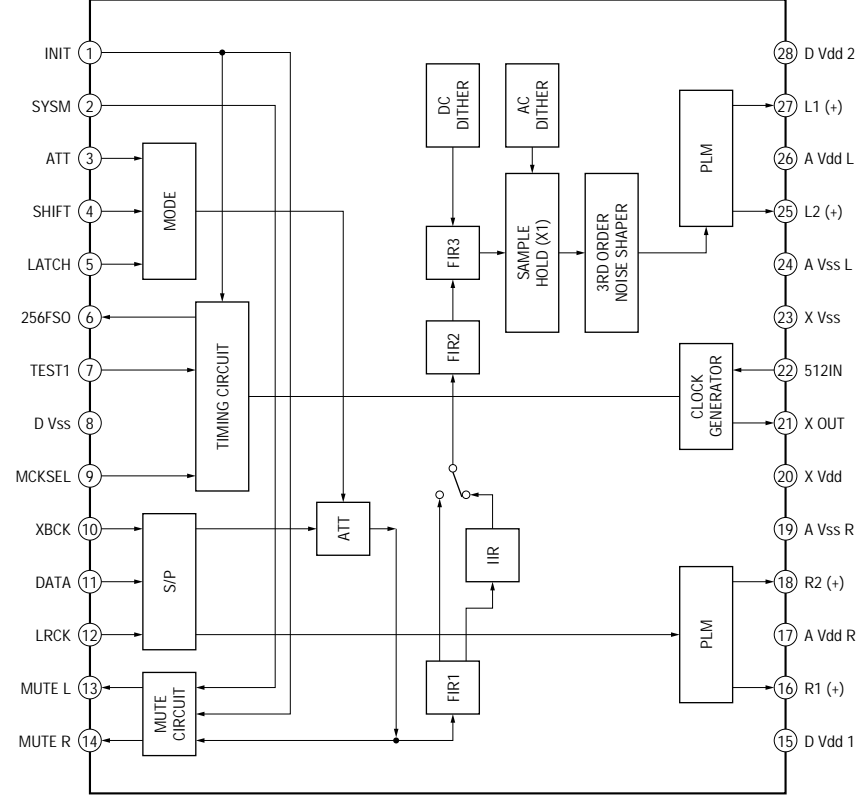

IC603 M5293L

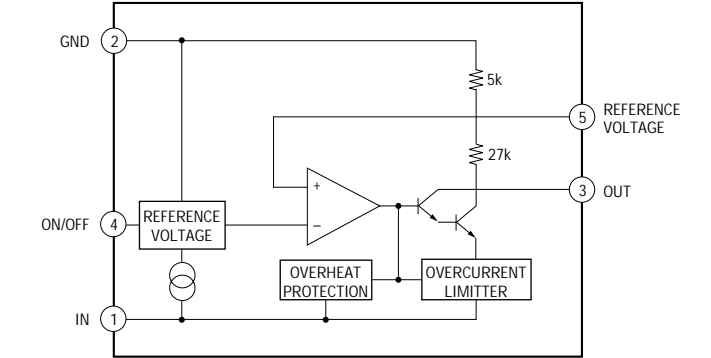

IC102 BA6392FP

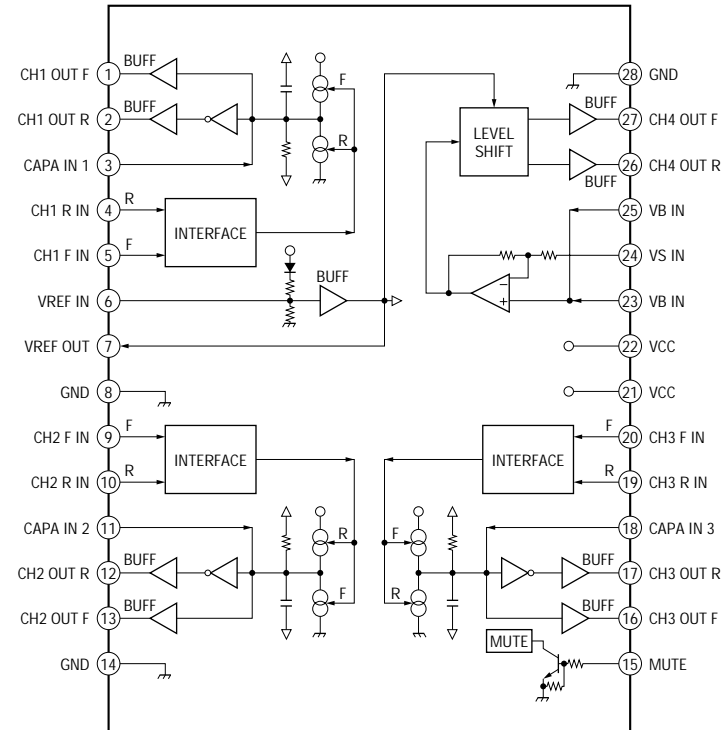

IC103 CXA1821M

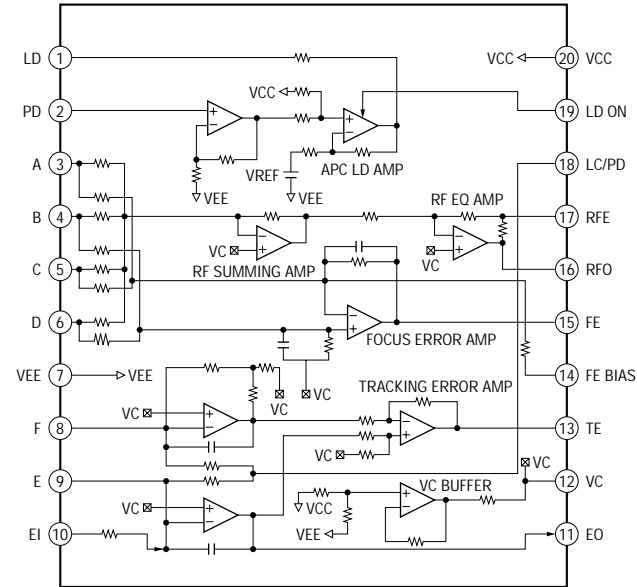

IC601 LA5602

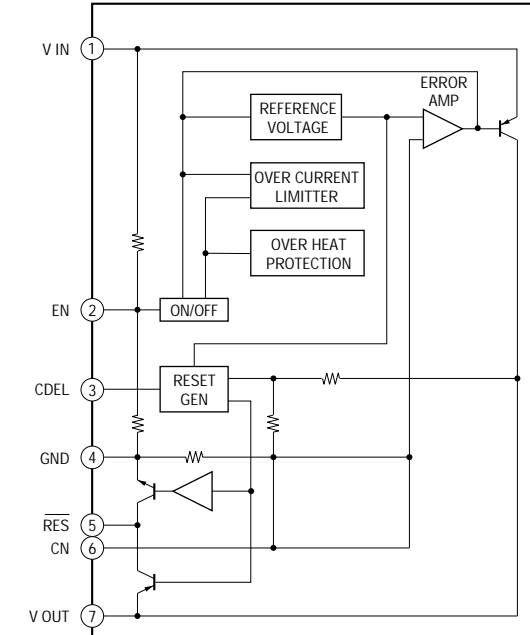

4-9. IC PIN FUNCTIONS

• IC101 DIGITAL SIGNAL PROCESSOR (CXD2545Q)

Pin No.	Pin Name	I/O	Function
1	SRON	O	Sled drive output (Not used)
2	SRDR	O	Sled drive output
3	SFON	O	Sled drive output (Not used)
4	TFDR	O	Tracking drive output
5	TRON	O	Tracking drive output (Not used)
6	TRDR	O	Tracking drive output
7	TFON	O	Tracking drive output (Not used)
8	FFDR	O	Focus drive output
9	FRON	O	Focus drive output (Not used)
10	FRDR	O	Focus drive output
11	FFON	O	Focus drive output (Not used)
12	VCOO	O	VCO output for analog EFM PLL (Not used)
13	VCOI	I	VCO output for analog EFM PLL (Ground)
14	TEST	I	TEST pin connected normally to ground
15	DVss	—	Digital ground
16	TES2	I	TEST pin connected normally to ground
17	TES3	I	TEST pin connected normally to ground
18	PDO	O	Charge-pump output for analog EFM PLL (Not used)
19	VPCO	O	Charge-pump output for variable pitch PLL (Not used)
20	VCKI	I	Clock input from variable pitch external VCO (Ground)
21	AVD2	—	Analog power supply
22	IGEN	I	Power supply pin for operational amplifiers
23	AVS2	—	Analog ground
24	ADIO	I	(Not used)
25	RFC	O	(Not used)
26	RFDC	I	RF signal input
27	TE	I	Tracking error signal input
28	SE	I	Sled error signal input
29	FE	I	Focus error signal input
30	VC	I	Center voltage input pin
31	FILO	O	Filter output for master PLL
32	FILI	I	Filter input for master PLL
33	PCO	O	Charge-pump output for master PLL
34	CLTV	I	Control voltage input for master VCO
35	AVS1	—	Analog ground
36	RFAC	I	EFM signal input
37	BIAS	I	Asymmetry circuit constant current input
38	ASYI	I	Asymmetry compare voltage input
39	ASYO	O	EFM full swing output
40	AVD1	—	Analog power supply

Pin No.	Pin Name	I/O	Function
41	DVDD	—	Digital power supply
42	ASYE	I	Asymmetry circuit ON/OFF
43	PSSL	I	Audio data output mode selection input
44	WDCK	O	48-bit slot D/A interface. Word clock.
45	LRCK	O	48-bit slot D/A interface. LR clock.
46	DATA	O	DA 16 output when PSSL=1.48-bit slot serial data when PSSL=0
47	BCLK	O	DA 15 output when PSSL=1.48-bit slot data when PSSL=0
48	64DATA	O	DA 14 output when PSSL=1.64-bit slot data when PSSL=0 (Not used)
49	64BCLK	O	DA 13 output when PSSL=1.64-bit slot data when PSSL=0 (Not used)
50	64LRCK	O	DA 12 output when PSSL=1.64-bit slot data when PSSL=0 (Not used)
51	GTOP	O	DA 11 output when PSSL=1.GTOP output when PSSL=0 (Not used)
52	XUGF	O	DA 10 output when PSSL=1.XUGF output when PSSL=0 (Not used)
53	XPLCK	O	DA 09 output when PSSL=1.XPLCK output when PSSL=0
54	GFS	O	DA 08 output when PSSL=1.GFS output when PSSL=0
55	PFCK	O	DA 07 output when PSSL=1.RFCK output when PSSL=0
56	C2PO	O	DA 06 output when PSSL=1.C2PO output when PSSL=0 (Not used)
57	XRA0F	O	DA 05 output when PSSL=1.XRA0F output when PSSL=0
58	MNT3	O	DA 04 output when PSSL=1.MNT3 output when PSSL=0
59	MNT2	O	DA 03 output when PSSL=1.MNT2 output when PSSL=0
60	MNT1	O	DA 02 output when PSSL=1.MNT1 output when PSSL=0
61	MNT0	O	DA 01 output when PSSL=1.MNT0 output when PSSL=0
62	XTAI	I	X'tal oscillator circuit input
63	XTAO	O	X'tal oscillator circuit output (Not used)
64	XTSL	I	X'tal selection input pin (Ground)
65	DVss	—	Digital ground
66	FSTI	I	2/3 divider output of pins 62, 63
67	FSTO	O	2/3 divider output of pins 62, 63
68	FSOF	O	(Not used)
69	C16M	O	16.9344 MHz output (Not used)
70	MD2	I	Digital-out ON/OFF control pin (+5V)
71	DOUT	O	Digital-out output pin
72	EMPH	O	Playback disc output in emphasis mode (Not used)
73	WFCK	O	WFCK output
74	SCOR	O	Sub-code sync output
75	SBSO	O	Sub-P through Sub-W serial output (Not used)
76	EXCK	I	Clock input for SBS0 read-out (Ground)
77	SUBQ	O	Sub-Q 80-bit output
78	SQCK	I	Muting selection pin
79	MUTE	I	SENS output
80	SENS	O	System reset

Pin No.	Pin Name	I/O	Function
81	XRST	I	System reset
82	DIRC	I	Used in 1-track jump mode (+5v)
83	SCLK	I	SENS serial data read-out clock
84	DFSW	I	DFCT selection pin (Ground)
85	ATSK	I	Input pin for anti-shock (Ground)
86	DATA	I	Serial data input, supplied from CPU
87	XLAT	I	Latch input, supplied from CPU
88	CLOK	I	Serial data transfer clock input, supplied from CPU
89	COUT	O	Numbers of track counted signal output (Not used)
90	DVDD	—	Digital power supply
91	MIRR	O	Mirror signal output
92	DFCT	O	Defect signal output
93	FOK	O	Focus OK output
94	FSW	O	Output to select spindle motor output filter (Not used)
95	MON	O	Output to control ON/OFF of spindle motor (Not used)
96	NDP	O	Output to control spindle motor servo
97	MDS	O	Output to control spindle motor servo (Not used)
98	LOCK	O	GFS is sampled by 460 Hz. H when GFS is H (Not used)
99	SSTP	I	Input signal to detect disc inner most track
100	SFDR	O	Sled drive output

• IC302 SYSTEM CONTROL (CXP82324-082Q)

Pin No.	Pin Name	I/O	Function
1	BUS IN	I	Not used. (Pull up)
2	RM IN	I	Remote control signal input
3	ADJ	I	ADJ mode setting pin
4	XLT	O	CXD2545 latch output
5	LD ON	O	Laser diode ON output
6	TSENS	I	Table position sensor input
7	PRGL	O	CXD8567 latch output
8	CLK	O	CXD2545/CXD8567 serial clock output
9	AMUTE	O	Mute output pin
10	DATA	O	CXD2545/CXD8567 serial data output
11	SQCK	O	Subcode Q read clock
12	SUBQ	I	Subcode Q read data input
13	SCLK	O	CXD2545 data read serial clock output
14	S1	I	CDM27 table rotary encoder input 1
15	S2	I	CDM27 table rotary encoder input 2
16	S3	I	CDM27 table rotary encoder input 3
17	LED	O	Not used. (Open)
18	LDOUT	O	Loading-out output
19	LDIN	O	Loading-in output
20	TBLL	O	Rotary table rotation counter-clockwise rotation output
21	TBLR	O	Rotary table rotation clockwise rotation output
22	CD123	I	Not used. (Pull up)
23	KEY1	I	A/D input 1 for key input
24	KEY2	I	A/D input 2 for key input
25	KEY3	I	A/D input 3 for key input
26	KEY4	O	Not used. (Open)
27	KEY5	O	Not used. (Open)
28	KEY6	I	A/D input 6 for key input
29	VERSION	I	Version setting input pin
30	XRST	I	Reset input
31	EXTAL	—	Oscillator connection pin
32	XTAL	—	Oscillator connection pin
33	V _{ss}	—	Ground
34 to 37	NC	O	Not used. (Open)
38	P1	O	FL display tube segment output 1
39	P2	O	FL display tube segment output 2
40	P3	O	FL display tube segment output 3

Pin No.	Pin Name	I/O	Function
41	P4	O	FL display tube segment output 4
42	P5	O	FL display tube segment output 5
43	P6	O	FL display tube segment output 6
44	P7	O	FL display tube segment output 7
45	P8	O	FL display tube segment output 8
46	P9	O	FL display tube segment output 9
47	P10	O	FL display tube segment output 10
48	P11	O	FL display tube segment output 11
49	P12	O	FL display tube segment output 12
50	P13	O	FL display tube segment output 13
51	P14	O	FL display tube segment output 14
52	P15	O	FL display tube segment output 15
53	P16	O	FL display tube segment output 16
54	P17	O	FL display tube segment output 17
55	P18	O	FL display tube segment output 18
56	P19	O	FL display tube segment output 19
57	P20	O	FL display tube segment output 20
58 to 62	NC	O	Not used. (Open)
63	G1	O	FL display tube grid output 1
64	G2	O	FL display tube grid output 2
65	G3	O	FL display tube grid output 3
66	G4	O	FL display tube grid output 4
67	G5	O	FL display tube grid output 5
68	G6	O	FL display tube grid output 6
69	G7	O	FL display tube grid output 7
70	G8	O	FL display tube grid output 8
71	VG	—	FL display tube filament voltage (–30 V)
72	VDD	—	+5V
73	NC	—	+5V
74	NC	O	Not used. (Open)
75	NC	O	Not used. (Open)
76	AFADJ	I	AFADJ mode setting pin
77	BUS OUT	O	Not used. (Open)
78	DSSENS	I	Disc sensor input
79	SENS	I	CXD2545 internal state monitor input
80	SCOR	I	Subcode sync. input

SECTION 5 EXPLODED VIEWS

NOTE:

- Items marked “*” are not stocked since they are seldom required for routine service. Some delay should be anticipated when ordering these items.
 - The mechanical parts with no reference number in the exploded views are not supplied.
 - Hardware (#mark) list is given in the last of this parts list.
- Abbreviation
 CND : Canadian model
 EE : East European model
 AUS : Australian model
 AED: North European model
 SP: Singapore model

The components identified by mark \triangle or dotted line with mark \triangle are critical for safety. Replace only with part number specified.

Les composants identifiés par une marque \triangle sont critiques pour la sécurité. Ne les remplacer que par une pièce portant le numéro spécifié.

5-1. FRONT PANEL AND CASE SECTION

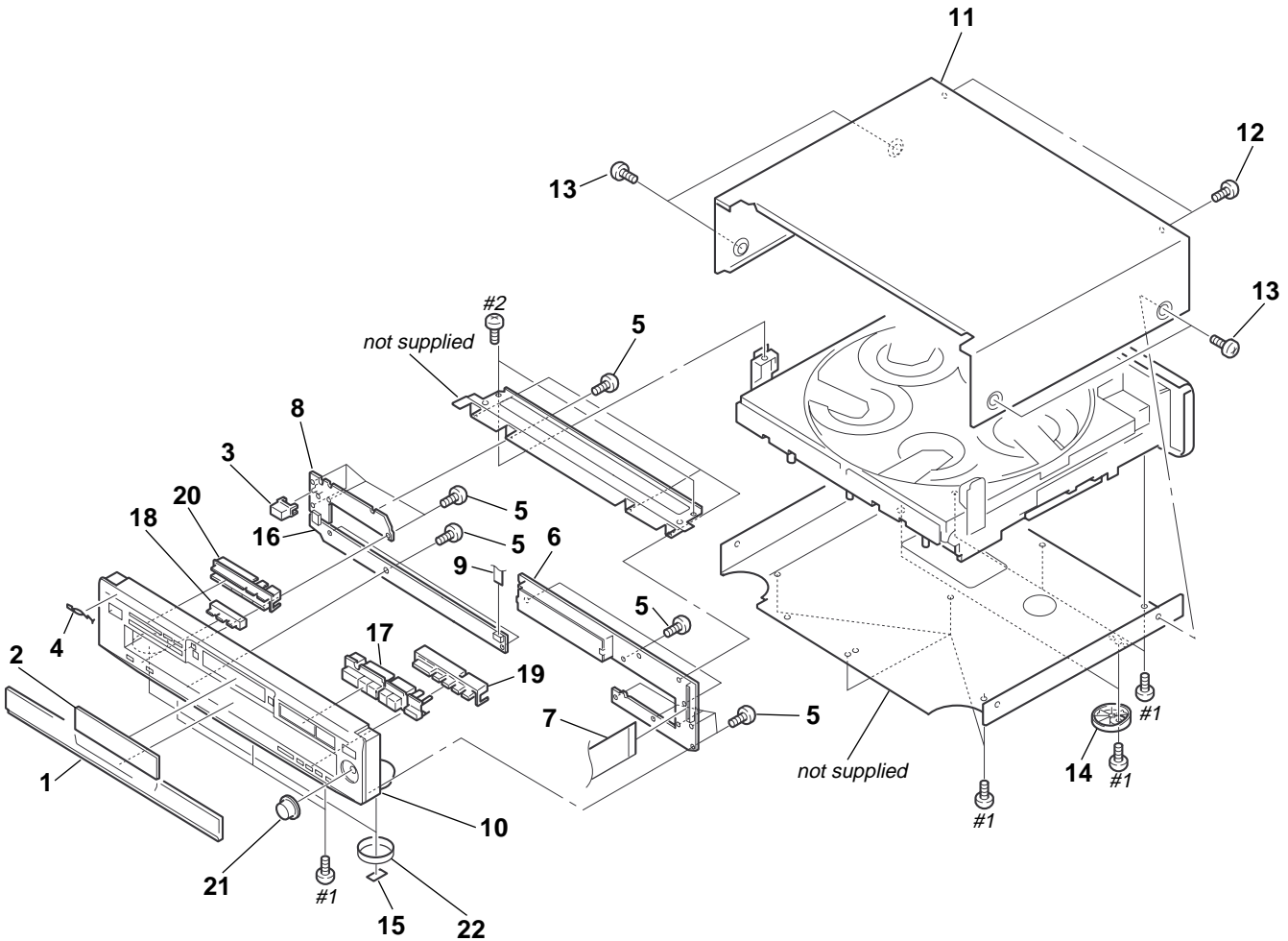

Ref. No.	Part No.	Description	Remarks	Ref. No.	Part No.	Description	Remarks
1	4-987-780-01	PANEL, LOADING		* 11	4-978-492-11	CASE	
2	4-987-779-01	WINDOW (FL) (C160Z/CE215)		12	3-703-685-21	SCREW (+BV 3X8)	
2	4-987-779-11	WINDOW (FL) (C260Z/CE315)		13	3-704-366-01	SCREW (CASE) (M3X8)	
3	4-977-589-01	BUTTON (POWER)		14	X-4946-618-1	FOOT ASSY (US,CND)	
4	3-008-600-01	EMBLEM (5-AR), SONY		14	X-4946-641-1	FOOT ASSY (EXCEPT US,CND)	
5	4-951-620-01	SCREW (2.6X8), +BVTP		* 15	4-978-398-21	CUSHION	
* 6	1-664-522-11	DISPLAY BOARD		* 16	1-664-524-11	KEY BOARD	
7	1-777-837-11	WIRE (FLAT TYPE) (35 CORE)		17	4-987-775-01	BUTTON (PLAY)	
* 8	1-664-523-11	POWER SW BOARD		18	4-987-776-01	BUTTON (FUNC)(CE215/CE315)	
9	1-777-838-11	WIRE (FLAT TYPE) (6 CORE)		19	4-987-777-01	BUTTON (FF)	
10	4-987-773-01	PANEL, FRONT (CE215)		20	4-987-774-01	BUTTON (MODE)	
10	4-987-773-11	PANEL, FRONT (CE315)		21	4-987-994-01	KNOB (AMS)	
10	4-987-773-21	PANEL, FRONT (C160Z)		22	4-977-593-01	RING (DIA. 50), ORNAMENTAL	
10	4-987-773-71	PANEL, FRONT (C260Z)					(EXCEPT US,CND)

5-2. BACK PANEL AND DISC TABLE SECTION

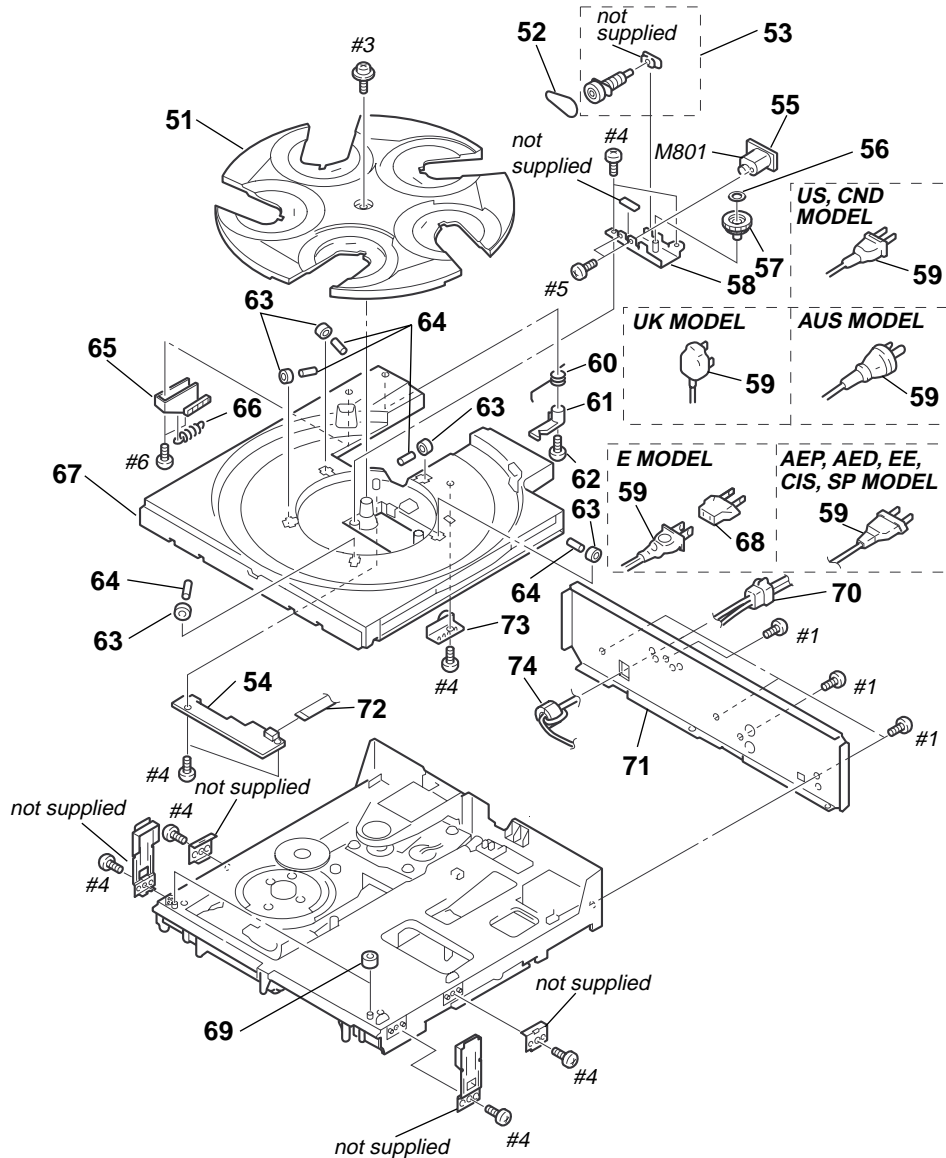

Ref. No.	Part No.	Description	Remarks	Ref. No.	Part No.	Description	Remarks
51	4-957-299-11	TABLE (B), DISC		△ 68	1-569-007-11	ADAPTOR, CONVERSION 2P (E)	
52	4-957-304-01	BELT (RM)		* 69	4-951-619-01	CUSHION (A)	
53	X-4943-479-1	GEAR (ROTARY A) ASSY		* 70	3-703-244-00	BUSHING (2104), CORD (EXCEPT E)	
* 54	1-659-737-11	SENSOR BOARD		* 70	3-703-571-11	BUSHING (S) (4516), CORD (E)	
* 55	1-647-364-11	TABLE MOTOR BOARD		* 71	4-987-782-01	PANEL, BACK (CE215:US)	
				* 71	4-987-782-11	PANEL, BACK (CE215:CND)	
56	3-325-697-01	WASHER		* 71	4-987-782-21	PANEL, BACK (CE215:AEP)	
57	4-957-284-01	GEAR (ROTARY B)		* 71	4-987-782-31	PANEL, BACK (CE215:AUS)	
58	X-4943-477-1	BRACKET (RM) ASSY		* 71	4-987-782-41	PANEL, BACK (C160Z,US)	
△ 59	1-558-943-61	CORD, POWER (E)		* 71	4-987-783-01	PANEL, BACK (CE315:AEP,AED,EE,CIS)	
△ 59	1-575-651-21	CORD, POWER (AEP,AED,EE,CIS,SP)		* 71	4-987-783-11	PANEL, BACK (CE315:UK)	
△ 59	1-590-926-11	CORD, POWER (US,CND)		* 71	4-987-783-21	PANEL, BACK (CE315:SP)	
△ 59	1-696-845-11	CORD, POWER (AUS)		* 71	4-987-783-31	PANEL, BACK (CE315:AUS)	
△ 59	1-751-529-11	CORD, POWER (UK)		* 71	4-987-783-41	PANEL, BACK (CE315:E)	
60	4-957-293-01	SPRING (RACK RELEASE)		* 71	4-987-783-51	PANEL, BACK (CE315:US)	
				* 71	4-987-783-61	PANEL, BACK (CE315:CND)	
61	4-957-291-11	LEVER (RACK RELEASE)		* 71	4-987-783-71	PANEL, BACK (C260Z:US)	
62	4-957-868-01	SCREW (+PTPWH 2.6X20)		* 71	4-987-783-81	PANEL, BACK (C260Z:CND)	
63	X-4924-457-1	ROLLER ASSY		72	1-751-052-11	WIRE (FLAT TYPE) (6 CORE)	
64	4-934-376-01	SHAFT (ROLLER)					
65	4-957-292-11	SLIDER (RACK)		73	X-4943-480-1	BRACKET (ROLLER D) ASSY	
				74	1-500-455-11	CORE, FERRITE	
66	4-957-294-01	SPRING (D.T), TENSION		M801	A-4660-525-A	MOTOR ASSY, ROTARY (TABLE)	
67	4-957-298-01	TABLE (A), DISC					

The components identified by mark △ or dotted line with mark △ are critical for safety. Replace only with part number specified.

Les composants identifiés par une marque △ sont critiques pour la sécurité. Ne les remplacer que par une pièce portant le numéro spécifié.

5-3. CHASSIS SECTION

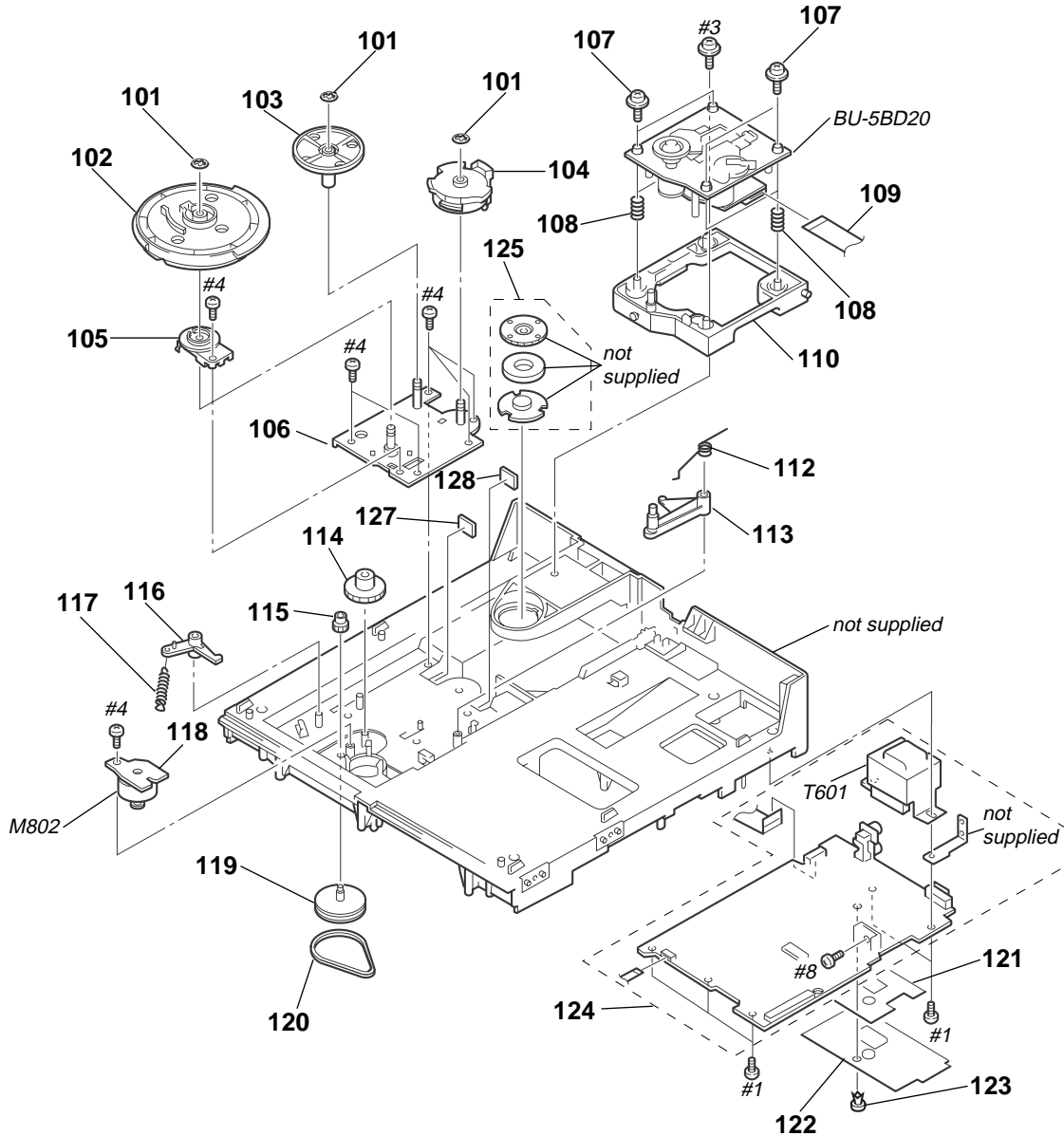

Ref. No.	Part No.	Description	Remarks	Ref. No.	Part No.	Description	Remarks
101	4-957-283-01	WASHER (5), STOPPER		120	4-944-490-01	BELT (TIMING)	
102	4-957-288-01	GEAR (MAIN)		* 121	4-957-555-01	SHEET, INSULATING (EXCEPT US,CND)	
103	4-957-287-01	GEAR (REV)		* 122	4-957-556-01	SHEET, INSULATING (EXCEPT US,CND)	
104	4-957-286-01	GEAR (U/D)		123	3-531-576-11	RIVET (EXCEPT US,CND)	
105	1-466-996-11	ENCODER, ROTARY		* 124	A-4699-469-A	MAIN BOARD, COMPLETE (C160Z/C260Z)	
				* 124	A-4699-472-A	MAIN BOARD, COMPLETE	(CE215:AUS/CE315:AUS,SP)
106	X-4946-195-1	BRACKET (GEAR) ASSY		* 124	A-4699-476-A	MAIN BOARD, COMPLETE	(CE215:US,CND/CE315:US,CND)
107	4-933-134-01	SCREW (+PTPWH M2.6X6)		* 124	A-4699-477-A	MAIN BOARD, COMPLETE	(CE215:AEP/CE315:AEP,UK,AED,EE,CIS)
108	4-948-503-01	SPRING (BU), COMPRESSION		* 124	A-4699-565-A	MAIN BOARD, COMPLETE (CE315:E)	
109	1-765-443-11	WIRE (FLAT TYPE) (23 CORE)					
110	4-957-289-12	HOLDER (BU)		125	1-452-838-12	MAGNET (ASSY)	
				* 127	4-981-731-01	CUSHION (U/D)	
112	4-957-281-01	SPRING (LOCK LEVER)		* 128	4-981-731-11	CUSHION (U/D)	
113	4-957-279-11	LEVER, LOCK		△ T601	1-429-956-11	TRANSFORMER, POWER (US,CND)	
114	4-957-303-01	GEAR (LOADING C)		△ T601	1-431-076-11	TRANSFORMER, POWER (EXCEPT US,CND,E)	
115	4-934-375-01	GEAR (LOADING B)		△ T601	1-431-168-11	TRANSFORMER, POWER (E)	
116	4-957-285-01	LEVER, SET		M802	A-4660-914-A	MOTOR ASSY (LOADING)	
117	4-962-087-01	SPRING (S), TENSION					
* 118	1-659-738-11	LOADING MOTOR BOARD					
119	X-4941-529-1	PULLEY ASSY					

<p>The components identified by mark Δ or dotted line with mark Δ are critical for safety. Replace only with part number specified.</p>	<p>Les composants identifiés par une marque Δ sont critiques pour la sécurité. Ne les remplacer que par une pièce portant le numéro spécifié.</p>
---	---

5-4. BASE UNIT SECTION (BU-5BD20)

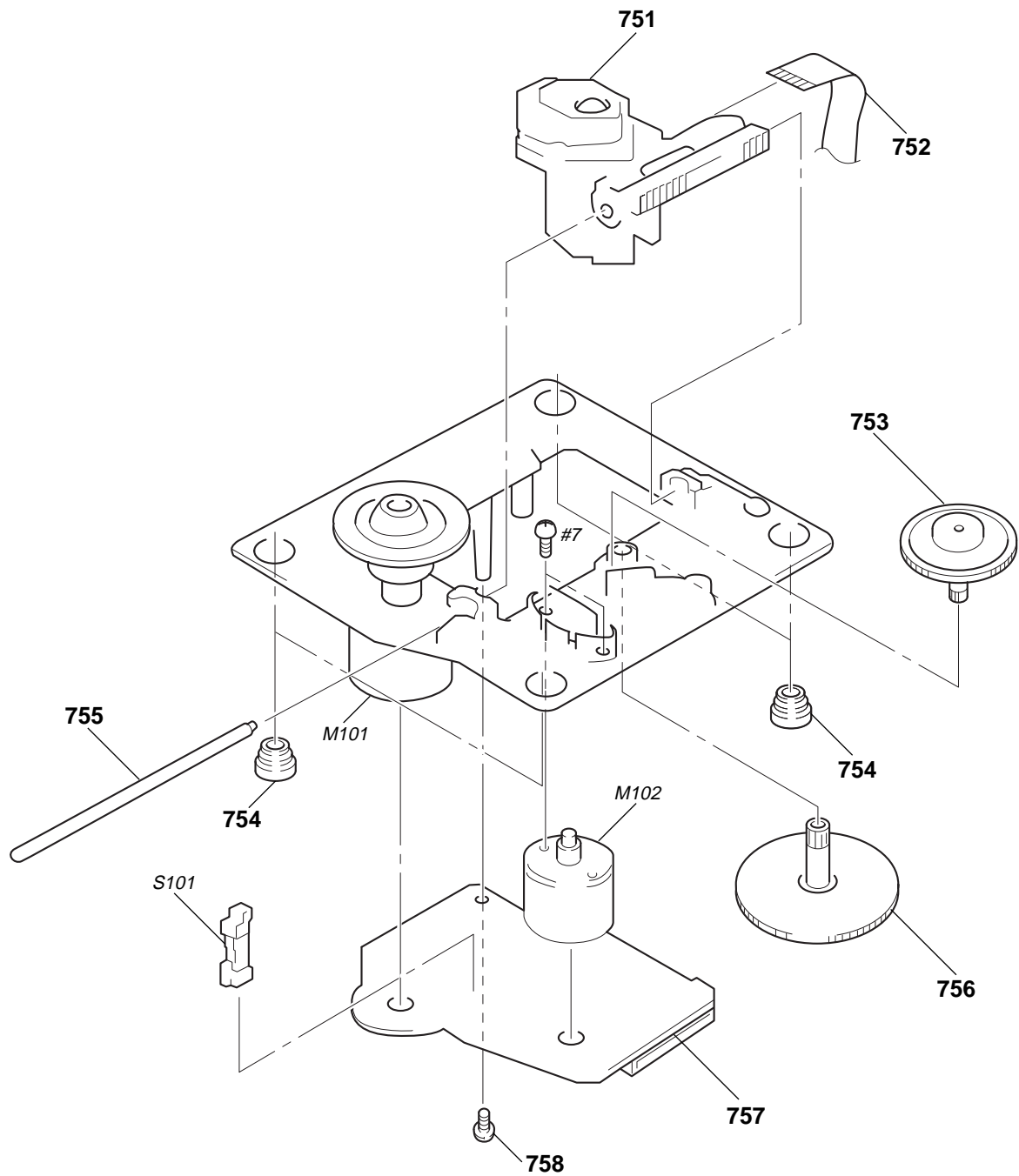

Ref. No.	Part No.	Description	Remarks	Ref. No.	Part No.	Description	Remarks
△ 751	8-848-379-31	OPTICAL PICK UP KSS-213BA/F-NP		* 757	A-4673-510-A	BD BOARD, COMPLETE	
752	1-769-069-11	WIRE (FLAT TYPE) (16 CORE)		758	4-951-620-01	SCREW (2.6X8), +BVTP	
753	4-917-567-01	GEAR (M)		M101	X-4917-523-3	MOTOR ASSY (SPINDLE)	
754	4-951-940-01	INSULATOR (BU)		M102	X-4917-504-1	MOTOR ASSY (SLED)	
755	4-917-565-01	SHAFT, SLED		S101	1-572-085-11	SWITCH, LEAF (LIMIT)	
756	4-917-564-01	GEAR (P), FLATNESS					

<p>The components identified by mark △ or dotted line with mark △ are critical for safety. Replace only with part number specified.</p>	<p>Les composants identifiés par une marque △ sont critiques pour la sécurité. Ne les remplacer que par une pièce portant le numéro spécifié.</p>
---	---

SECTION 6 ELECTRICAL PARTS LIST

BD

DISPLAY

NOTE:

When indicating parts by reference number, please include the board name.

The components identified by mark Δ or dotted line with mark Δ are critical for safety. Replace only with part number specified.

Les composants identifiés par une marque Δ sont critiques pour la sécurité. Ne les remplacer que par une pièce portant le numéro spécifié.

- Due to standardization, replacements in the parts list may be different from the parts specified in the diagrams or the components used on the set.
- Items marked “*” are not stocked since they are seldom required for routine service. Some delay should be anticipated when ordering these items.
- RESISTORS
All resistors are in ohms
METAL: Metal-film resistor
F : nonflammable
- SEMICONDUCTORS
In each case, u: μ , for example:
uA...: μ A..., uPA...: μ PA..., uPB...: μ PB...,
uPC...: μ PC..., uPD...: μ PD...
- CAPACITORS
uF : μ F
COILS
uH : μ H
- Abbreviation
CND : Canadian model
EE : East European model
AUS : Australian model
AED: North European model
SP: Singapore model

Ref. No.	Part No.	Description	Remarks	Ref. No.	Part No.	Description	Remarks
*	A-4673-510-A	BD BOARD, COMPLETE *****				< RESISTOR >	
		< CAPACITOR >		R101	1-216-077-00	METAL CHIP 15K 5%	1/10W
C101	1-163-005-11	CERAMIC CHIP 470PF 10%	50V	R102	1-216-097-00	METAL GLAZE 100K 5%	1/10W
C102	1-163-038-00	CERAMIC CHIP 0.1uF	25V	R103	1-216-077-00	METAL CHIP 15K 5%	1/10W
C103	1-163-005-11	CERAMIC CHIP 470PF 10%	50V	R104	1-216-085-00	METAL CHIP 33K 5%	1/10W
C105	1-135-155-21	TANTALUM CHIP 4.7uF 10%	16V	R105	1-216-097-00	METAL GLAZE 100K 5%	1/10W
C106	1-164-346-11	CERAMIC CHIP 1uF	16V	R106	1-216-061-00	METAL CHIP 3.3K 5%	1/10W
C107	1-164-346-11	CERAMIC CHIP 1uF	16V	R107	1-216-061-00	METAL CHIP 3.3K 5%	1/10W
C108	1-163-035-00	CERAMIC CHIP 0.047uF	50V	R108	1-216-073-00	METAL CHIP 10K 5%	1/10W
C109	1-163-145-00	CERAMIC CHIP 0.0015uF 5%	50V	R109	1-216-121-00	METAL GLAZE 1M 5%	1/10W
C110	1-163-017-00	CERAMIC CHIP 0.0047uF 5%	50V	R110	1-216-025-00	METAL GLAZE 100 5%	1/10W
C111	1-163-251-11	CERAMIC CHIP 100PF 5%	50V	R112	1-216-049-11	METAL GLAZE 1K 5%	1/10W
C112	1-163-038-00	CERAMIC CHIP 0.1uF	25V	R123	1-216-073-00	METAL CHIP 10K 5%	1/10W
C113	1-163-038-00	CERAMIC CHIP 0.1uF	25V	R124	1-216-097-00	METAL GLAZE 100K 5%	1/10W
C115	1-126-607-11	ELECT CHIP 47uF 20%	4V	R125	1-216-049-11	METAL GLAZE 1K 5%	1/10W
C116	1-126-607-11	ELECT CHIP 47uF 20%	4V	R126	1-216-049-11	METAL GLAZE 1K 5%	1/10W
C117	1-126-209-11	ELECT 100uF 20%	4V	R127	1-216-049-11	METAL GLAZE 1K 5%	1/10W
C118	1-163-275-11	CERAMIC CHIP 0.001uF 5%	50V	R131	1-216-037-00	METAL CHIP 330 5%	1/10W
C119	1-163-231-11	CERAMIC CHIP 15PF 5%	50V	R135	1-216-295-00	CONDUCTOR, CHIP (2012)	
C123	1-164-232-11	CERAMIC CHIP 0.01uF	50V	R136	1-216-295-00	CONDUCTOR, CHIP (2012)	
C124	1-164-005-11	CERAMIC CHIP 0.47uF	25V	R137	1-216-295-00	CONDUCTOR, CHIP (2012)	
C124	1-164-005-11	CERAMIC CHIP 0.47uF	25V	R138	1-216-295-00	CONDUCTOR, CHIP (2012)	
C140	1-163-038-00	CERAMIC CHIP 0.1uF	25V	R141	1-216-089-00	METAL GLAZE 47K 5%	1/10W
C141	1-163-038-00	CERAMIC CHIP 0.1uF	25V	R142	1-216-081-00	METAL CHIP 22K 5%	1/10W
C151	1-163-237-11	CERAMIC CHIP 27PF 5%	50V	R143	1-216-103-00	METAL CHIP 180K 5%	1/10W
C153	1-163-038-00	CERAMIC CHIP 0.1uF	25V	R144	1-216-103-00	METAL CHIP 180K 5%	1/10W
C154	1-164-336-11	CERAMIC CHIP 0.33uF	25V	R146	1-216-073-00	METAL CHIP 10K 5%	1/10W
C156	1-163-237-11	CERAMIC CHIP 27PF 5%	50V	R147	1-216-081-00	METAL CHIP 22K 5%	1/10W
C157	1-163-145-00	CERAMIC CHIP 0.0015uF 5%	50V	R148	1-216-001-00	METAL CHIP 10 5%	1/10W
C159	1-163-019-00	CERAMIC CHIP 0.0068uF 10%	50V	R149	1-216-003-11	METAL GLAZE 12 5%	1/10W
C161	1-163-038-00	CERAMIC CHIP 0.1uF	25V	R158	1-216-111-00	METAL GLAZE 390K 5%	1/10W
		< CONNECTOR >		R159	1-216-101-00	METAL CHIP 150K 5%	1/10W
CN101	1-770-072-11	CONNECTOR,(LIF(NON-ZIF))FFC23P		R160	1-216-295-00	CONDUCTOR, CHIP (2012)	
CN102	1-770-014-11	CONNECTOR, FFC/FPC 16P		R161	1-216-308-00	METAL CHIP 4.7 5%	1/10W
		< IC >		R162	1-216-101-00	METAL CHIP 150K 5%	1/10W
IC101	8-752-369-78	IC CXD2545Q				< SWITCH >	
IC102	8-759-176-09	IC BA6392FP		S101	1-572-085-11	SWITCH, LEAF (LIMIT)	
IC103	8-752-072-45	IC CXA1821M		*****			
		< TRANSISTOR >		*	1-664-522-11	DISPLAY BOARD	
Q101	8-729-010-08	TRANSISTOR MSB710-R		*****			
		< CAPACITOR >		C801	1-126-968-11	ELECT 100uF 20%	6.3V

DISPLAY	KEY	LOADING MOTOR	MAIN
----------------	------------	----------------------	-------------

Ref. No.	Part No.	Description	Remarks	Ref. No.	Part No.	Description	Remarks
		< CONNECTOR >				< SWITCH >	
* CN810	1-691-958-11	SOCKET, CONNECTOR 35P		S713	1-554-303-21	SWITCH, TACTILE (PEAK SEARCH) (CE215/CE315)	
		< FILTER >		S714	1-554-303-21	SWITCH, TACTILE (EDIT/TIME FADE) (CE215/CE315)	
FL810	1-517-616-11	TUBE, FLUORESCENT INDICATOR		S715	1-554-303-21	SWITCH, TACTILE (TIME)(CE215/CE315)	
		< IC >		*****			
IC810	8-759-459-84	IC NJL56H400		*	1-659-738-11	LOADING MOTOR BOARD *****	
		< RESISTOR >				< MOTOR >	
R801	1-247-807-31	CARBON 100 5%	1/4W	M802	A-4660-914-A	MOTOR ASSY (LOADING) *****	
R802	1-247-807-31	CARBON 100 5%	1/4W				
R811	1-249-415-11	CARBON 680 5%	1/4W F	*	A-4699-469-A	MAIN BOARD, COMPLETE (C160Z/C260Z) *****	
R812	1-249-417-11	CARBON 1K 5%	1/4W F	*	A-4699-472-A	MAIN BOARD, COMPLETE *****	
R813	1-249-419-11	CARBON 1.5K 5%	1/4W F			(CE215:AUS/CE315:AUS,SP)	
R814	1-249-421-11	CARBON 2.2K 5%	1/4W F	*	A-4699-476-A	MAIN BOARD, COMPLETE *****	
R815	1-247-843-11	CARBON 3.3K 5%	1/4W			(CE215:US,CND/CE315:US,CND)	
R816	1-249-427-11	CARBON 6.8K 5%	1/4W F	*	A-4699-477-A	MAIN BOARD, COMPLETE *****	
R817	1-249-415-11	CARBON 680 5%	1/4W F			(CE215:AEP/CE315:AEP,UK,AED,EE,CIS)	
R818	1-249-417-11	CARBON 1K 5%	1/4W F	*	A-4699-565-A	MAIN BOARD, COMPLETE (CE315:E) *****	
R819	1-249-419-11	CARBON 1.5K 5%	1/4W F				
R820	1-249-421-11	CARBON 2.2K 5%	1/4W F				
R821	1-247-843-11	CARBON 3.3K 5%	1/4W				
R822	1-249-427-11	CARBON 6.8K 5%	1/4W F				
R823	1-249-431-11	CARBON 15K 5%	1/4W				
R824	1-249-431-11	CARBON 15K 5%	1/4W		7-685-871-01	SCREW +BVTT 3X6 (S)	
		< SWITCH >				< CAPACITOR >	
S801	1-554-303-21	SWITCH, TACTILE (FADER)		C301	1-162-199-31	CERAMIC 10PF 5% 50V	
S802	1-554-303-21	SWITCH, TACTILE (MUSIC SCAN)		C302	1-162-199-31	CERAMIC 10PF 5% 50V	
S803	1-554-303-21	SWITCH, TACTILE (CLEAR)		C303	1-164-159-11	CERAMIC 0.1uF 50V	
S804	1-554-303-21	SWITCH, TACTILE (CHECK)		C304	1-164-159-11	CERAMIC 0.1uF 50V	
S805	1-554-303-21	SWITCH, TACTILE (▶▶)		C305	1-124-443-00	ELECT 100uF 20% 10V	
S806	1-554-303-21	SWITCH, TACTILE (◀◀)		C306	1-124-442-00	ELECT 330uF 20% 6.3V	
S808	1-554-303-21	SWITCH, TACTILE (OPEN/CLOSE)		C307	1-164-159-11	CERAMIC 0.1uF 50V	
S809	1-554-303-21	SWITCH, TACTILE (DISC SKIP)		C308	1-164-159-11	CERAMIC 0.1uF 50V	
S810	1-554-303-21	SWITCH, TACTILE (EX-CHANGE)		C316	1-164-159-11	CERAMIC 0.1uF 50V	
S811	1-554-303-21	SWITCH, TACTILE (■)		C317	1-161-494-00	CERAMIC 0.022uF 25V	
S812	1-554-303-21	SWITCH, TACTILE (■)		C374	1-104-664-11	ELECT 47uF 20% 16V (CE215:AEP/CE315:AEP,UK,AED,EE,CIS)	
S813	1-554-303-21	SWITCH, TACTILE (▷)		C375	1-161-494-00	CERAMIC 0.022uF 25V (CE215:AEP/CE315:AEP,UK,AED,EE,CIS)	
S814	1-473-957-11	ENCODER, ROTARY (AMS)		C401	1-162-282-31	CERAMIC 100PF 10% 50V	

*	1-664-524-11	KEY BOARD *****		C402	1-162-215-31	CERAMIC 47PF 5% 50V	
		< CONNECTOR >		C403	1-162-215-31	CERAMIC 47PF 5% 50V	
CN701	1-568-849-11	SOCKET, CONNECTOR 6P		C404	1-130-479-00	MYLAR 0.0047uF 5% 50V	
CN702	1-750-195-11	CONNECTOR, BOARD TO BOARD 6P		C405	1-130-472-00	MYLAR 0.0012uF 5% 50V	
		< RESISTOR >		C406	1-124-443-00	ELECT 100uF 20% 10V	
R713	1-249-415-11	CARBON 680 5%	1/4W F (CE215/CE315)	C407	1-161-494-00	CERAMIC 0.022uF 25V	
R714	1-249-417-11	CARBON 1K 5%	1/4W F (CE215/CE315)	C408	1-104-664-11	ELECT 47uF 20% 16V	
				C410	1-162-290-31	CERAMIC 470PF 10% 50V	
				C412	1-164-159-11	CERAMIC 0.1uF 50V	
				C501	1-162-282-31	CERAMIC 100PF 10% 50V	
				C502	1-162-215-31	CERAMIC 47PF 5% 50V	
				C503	1-162-215-31	CERAMIC 47PF 5% 50V	
				C504	1-130-479-00	MYLAR 0.0047uF 5% 50V	
				C505	1-130-472-00	MYLAR 0.0012uF 5% 50V	

MAIN

Ref. No.	Part No.	Description	Remarks	Ref. No.	Part No.	Description	Remarks
C506	1-124-443-00	ELECT	100uF 20% 10V			< COIL >	
C507	1-161-494-00	CERAMIC	0.022uF 25V				
C508	1-104-664-11	ELECT	47uF 20% 16V	L301	1-410-503-11	INDUCTOR 3.3uH	
C509	1-126-962-11	ELECT	3.3uF 20% 50V	L302	1-412-473-21	INDUCTOR 0uH	
C510	1-162-290-31	CERAMIC	470PF 10% 50V	L303	1-410-503-11	INDUCTOR 3.3uH	
C512	1-164-159-11	CERAMIC	0.1uF 50V	L304	1-410-503-11	INDUCTOR 3.3uH	
C602	1-126-944-11	ELECT	3300uF 20% 16V	L305	1-410-397-21	FERRITE BEAD INDUCTOR	
C603	1-126-942-61	ELECT	1000uF 20% 16V	L306	1-412-473-51	INDUCTOR 0uH	
C604	1-126-963-11	ELECT	4.7uF 20% 50V	L307	1-412-473-21	INDUCTOR 0uH	
C605	1-126-963-11	ELECT	4.7uF 20% 50V	L401	1-410-503-11	INDUCTOR 3.3uH	
C606	1-126-963-11	ELECT	4.7uF 20% 50V	L501	1-410-503-11	INDUCTOR 3.3uH	
C607	1-126-941-11	ELECT	470uF 20% 6.3V	L601	1-412-473-21	INDUCTOR 0uH	
C608	1-104-666-11	ELECT	220uF 20% 10V	L603	1-412-473-21	INDUCTOR 0uH	
C609	1-124-918-11	ELECT	47uF 20% 63V	L604	1-412-473-21	INDUCTOR 0uH	
C610	1-124-907-11	ELECT	10uF 20% 50V	L605	1-410-503-11	INDUCTOR 3.3uH	
C614	1-104-665-11	ELECT	100uF 20% 16V	L606	1-410-397-21	FERRITE BEAD INDUCTOR	
C616	1-161-494-00	CERAMIC	0.022uF 25V	L607	1-410-503-11	INDUCTOR 3.3uH	
C619	1-104-664-11	ELECT	47uF 20% 16V	L608	1-410-503-11	INDUCTOR 3.3uH	
C620	1-161-494-00	CERAMIC	0.022uF 25V	L609	1-412-473-21	INDUCTOR 0uH	
C622	1-161-494-00	CERAMIC	0.022uF 25V			< TRANSISTOR >	
C625	1-161-494-00	CERAMIC	0.022uF 25V	Q201	8-729-119-78	TRANSISTOR 2SC2785-HFE	
C626	1-161-494-00	CERAMIC	0.022uF 25V	Q402	8-729-141-26	TRANSISTOR 2SC3622A-LK	
C628	1-104-664-11	ELECT	47uF 20% 16V	Q404	8-729-119-78	TRANSISTOR 2SC2785-HFE	
C648	1-161-494-00	CERAMIC	0.022uF 25V	Q502	8-729-141-26	TRANSISTOR 2SC3622A-LK	
C649	1-161-494-00	CERAMIC	0.022uF 25V	Q503	8-729-029-56	TRANSISTOR DTA144ESA	
C651	1-104-664-11	ELECT	47uF 20% 16V	Q601	8-729-119-76	TRANSISTOR 2SA1175-HFE	
		< CONNECTOR >				< RESISTOR >	
CN401	1-750-640-11	CONNECTOR, FFC/FPC 23P		R205	1-249-430-11	CARBON 12K 5% 1/4W	
CN402	1-764-411-11	PIN, CONNECTOR (PC BOARD) 35P		R206	1-249-429-11	CARBON 10K 5% 1/4W	
CN403	1-568-849-11	SOCKET, CONNECTOR 6P		R251	1-249-429-11	CARBON 10K 5% 1/4W	
* CN404	1-568-825-11	SOCKET, CONNECTOR 6P		R252	1-249-426-11	CARBON 5.6K 5% 1/4W	
* CN601	1-573-047-11	PIN, CONNECTOR (PC BOARD) 2P		R253	1-249-425-11	CARBON 4.7K 5% 1/4W F	
		< DIODE >		R254	1-249-430-11	CARBON 12K 5% 1/4W	
D302	8-719-987-63	DIODE 1N4148M		R262	1-249-382-11	CARBON 1.2 5% 1/6W F	
D601	8-719-200-82	DIODE 11ES2		R263	1-249-382-11	CARBON 1.2 5% 1/6W F	
D602	8-719-200-82	DIODE 11ES2		R301	1-249-424-11	CARBON 3.9K 5% 1/4W F	
D603	8-719-200-82	DIODE 11ES2		R302	1-247-807-31	CARBON 100 5% 1/4W	
D604	8-719-200-82	DIODE 11ES2		R303	1-249-411-11	CARBON 330 5% 1/4W	
D605	8-719-200-82	DIODE 11ES2		R304	1-249-413-11	CARBON 470 5% 1/4W F	
D606	8-719-923-60	DIODE MTZJ-T-77-9.1A		R305	1-249-417-11	CARBON 1K 5% 1/4W F	
D608	8-719-987-63	DIODE 1N4148M		R308	1-249-429-11	CARBON 10K 5% 1/4W	
D609	8-719-010-34	DIODE UZ-4.7BSC		R309	1-249-417-11	CARBON 1K 5% 1/4W F	
		< IC >		R310	1-249-417-11	CARBON 1K 5% 1/4W F	
IC301	8-759-362-47	IC CXD8567AM		R311	1-249-425-11	CARBON 4.7K 5% 1/4W F	
IC302	8-752-884-93	IC CXP82324-082Q		R312	1-249-437-11	CARBON 47K 5% 1/4W	
IC304	8-759-356-03	IC BA6780		R313	1-249-429-11	CARBON 10K 5% 1/4W	
IC371	8-749-921-12	IC GP1F32T (DIGITAL OUT) (CE215:AEP/CE315:AEP,UK,AED,EE,CIS)		R314	1-249-425-11	CARBON 4.7K 5% 1/4W F	
IC401	8-759-145-58	IC uPC4558C		R315	1-249-425-11	CARBON 4.7K 5% 1/4W F	
IC501	8-759-145-58	IC uPC4558C		R316	1-249-425-11	CARBON 4.7K 5% 1/4W F	
IC601	8-759-061-65	IC LA5602		R317	1-249-427-11	CARBON 6.8K 5% 1/4W F	
IC602	8-749-011-78	IC BA17807T		R318	1-249-427-11	CARBON 6.8K 5% 1/4W F	
IC603	8-759-633-42	IC M5293L		R319	1-249-427-11	CARBON 6.8K 5% 1/4W F	
		< JACK >		R321	1-249-429-11	CARBON 10K 5% 1/4W	
J301	1-770-719-11	JACK, PIN 2P (LINE OUT)		R322	1-249-429-11	CARBON 10K 5% 1/4W	
				R323	1-249-441-11	CARBON 100K 5% 1/4W	
				R324	1-249-429-11	CARBON 10K 5% 1/4W	
				R325	1-249-429-11	CARBON 10K 5% 1/4W	

(C160Z/C260Z)

MAIN

POWER SW

SENSOR

TABLE MOTOR

Ref. No.	Part No.	Description	Remarks	Ref. No.	Part No.	Description	Remarks
R331	1-249-427-11	CARBON	6.8K 5%	1/4W	F		
R333	1-249-429-11	CARBON	10K 5%	1/4W		< SWITCH >	
R403	1-249-436-11	CARBON	39K 5%	1/4W			
R404	1-249-436-11	CARBON	39K 5%	1/4W			
R405	1-249-431-11	CARBON	15K 5%	1/4W			
R406	1-249-431-11	CARBON	15K 5%	1/4W			
R407	1-215-461-00	METAL	47K 1%	1/4W			
R408	1-215-461-00	METAL	47K 1%	1/4W			
R409	1-249-419-11	CARBON	1.5K 5%	1/4W	F		
R410	1-249-419-11	CARBON	1.5K 5%	1/4W	F		
R411	1-247-887-00	CARBON	220K 5%	1/4W			
R412	1-249-417-11	CARBON	1K 5%	1/4W	F		
R416	1-249-425-11	CARBON	4.7K 5%	1/4W	F		
R503	1-249-436-11	CARBON	39K 5%	1/4W			
R504	1-249-436-11	CARBON	39K 5%	1/4W			
R505	1-249-431-11	CARBON	15K 5%	1/4W			
R506	1-249-431-11	CARBON	15K 5%	1/4W			
R507	1-215-461-00	METAL	47K 1%	1/4W			
R508	1-215-461-00	METAL	47K 1%	1/4W			
R509	1-249-419-11	CARBON	1.5K 5%	1/4W	F		
R510	1-249-419-11	CARBON	1.5K 5%	1/4W	F		
R511	1-247-887-00	CARBON	220K 5%	1/4W			
R512	1-249-417-11	CARBON	1K 5%	1/4W	F		
R516	1-249-425-11	CARBON	4.7K 5%	1/4W	F		
R517	1-249-441-11	CARBON	100K 5%	1/4W			
R601	1-249-435-11	CARBON	33K 5%	1/4W			
R602	1-249-429-11	CARBON	10K 5%	1/4W			
R603	1-249-438-11	CARBON	56K 5%	1/4W			
R604	1-249-429-11	CARBON	10K 5%	1/4W			
R607	1-249-411-11	CARBON	330 5%	1/4W			
		< SWITCH >					
△S601	1-572-675-11	SWITCH, POWER VOLTAGE CHANGE (VOLTAGE SELECTOR)(E)					
		< VIBRATOR >					
X301	1-579-833-21	VIBRATOR, CRYSTAL 33MHZ					
X401	1-579-175-11	VIBRATOR, CERAMIC 10MHZ					

*	1-664-523-11	POWER SW BOARD *****					
		< CONNECTOR >					
CN703	1-750-186-11	CONNECTOR, BOARD TO BOARD 6P					
		< RESISTOR >					
R701	1-249-415-11	CARBON	680 5%	1/4W	F		
R702	1-249-417-11	CARBON	1K 5%	1/4W	F		
R703	1-249-419-11	CARBON	1.5K 5%	1/4W	F		
R704	1-249-421-11	CARBON	2.2K 5%	1/4W	F		
R705	1-247-843-11	CARBON	3.3K 5%	1/4W			
R706	1-249-427-11	CARBON	6.8K 5%	1/4W	F		
R707	1-249-431-11	CARBON	15K 5%	1/4W			
R708	1-249-419-11	CARBON	1.5K 5%	1/4W	F		
		(CE215/CE315)					
R709	1-249-421-11	CARBON	2.2K 5%	1/4W	F		
		(CE215/CE315)					
R709	1-249-415-11	CARBON	680 5%	1/4W	F		
		(C160Z/C260Z)					
S701	1-554-303-21	SWITCH, TACTILE (DISC 1)					
S702	1-554-303-21	SWITCH, TACTILE (DISC 2)					
S703	1-554-303-21	SWITCH, TACTILE (DISC 3)					
S704	1-554-303-21	SWITCH, TACTILE (DISC 4)					
S705	1-554-303-21	SWITCH, TACTILE (DISC 5)					
S706	1-554-303-21	SWITCH, TACTILE (CONTINUE)					
S707	1-554-303-21	SWITCH, TACTILE (SHUFFLE)					
S708	1-554-303-21	SWITCH, TACTILE (PROGRAM)					
S709	1-554-303-21	SWITCH, TACTILE (REPEAT)					
S710	1-554-303-21	SWITCH, TACTILE (CE215,CE315:DISC CHECK/C160Z,C260Z:TIME)					
S751	1-554-118-00	SWITCH, PUSH (1 KEY) (POWER)					

*	1-659-737-11	SENSOR BOARD *****					
		< CONNECTOR >					
CN851	1-573-383-11	PIN, CONNECTOR (PC BOARD) 2P					
CN852	1-750-243-11	SOCKET, CONNECTOR 6P					
		< DIODE >					
D851	8-749-924-18	DIODE PHOTO INTERRUPTER RPI-1391					
D852	8-749-924-30	DIODE PHOTO REFLECTOR GP2S28					
		< RESISTOR >					
R851	1-249-416-11	CARBON	820 5%	1/4W	F		
R852	1-249-406-11	CARBON	120 5%	1/4W	F		

*	1-647-364-11	TABLE MOTOR BOARD *****					
		< MOTOR >					
M801	A-4660-525-A	MOTOR ASSY, ROTARY (TABLE)					

MISCELLANEOUS *****							
7	1-777-837-11	WIRE (FLAT TYPE) (35 CORE)					
9	1-777-838-11	WIRE (FLAT TYPE) (6 CORE)					
△59	1-558-943-61	CORD, POWER (E)					
△59	1-575-651-21	CORD, POWER (AEP,AED,EE,CIS,SP)					
△59	1-590-926-11	CORD, POWER (US,CND)					
△59	1-696-845-11	CORD, POWER (AUS)					
△59	1-751-529-11	CORD, POWER (UK)					
△68	1-569-007-11	ADAPTOR, CONVERSION 2P (E)					
72	1-751-052-11	WIRE (FLAT TYPE) (6 CORE)					
74	1-500-455-11	CORE, FERRITE					
105	1-466-996-11	ENCODER, ROTARY					
109	1-765-443-11	WIRE (FLAT TYPE) (23 CORE)					
125	1-452-838-12	MAGNET (ASSY)					
△751	8-848-379-31	OPTICAL PICK UP KSS-213BA/F-NP					
752	1-769-069-11	WIRE (FLAT TYPE) (16 CORE)					

The components identified by mark △ or dotted line with mark △ are critical for safety. Replace only with part number specified.

Les composants identifiés par une marque △ sont critiques pour la sécurité. Ne les remplacer que par une pièce portant le numéro spécifique.

CDP-C160Z/C260Z/CE215/CE315

Ref. No.	Part No.	Description	Remarks
M101	X-4917-523-3	MOTOR ASSY (SPINDLE)	
M102	X-4917-504-1	MOTOR ASSY (SLED)	
M801	A-4660-525-A	MOTOR ASSY, ROTARY (TABLE)	
M802	A-4660-914-A	MOTOR ASSY (LOADING)	
S101	1-572-085-11	SWITCH, LEAF (LIMIT)	
△ T601	1-429-956-11	TRANSFORMER, POWER (US,CND)	
△ T601	1-431-076-11	TRANSFORMER, POWER (EXCEPT US,CND,E)	
△ T601	1-431-168-11	TRANSFORMER, POWER (E)	

ACCESSORIES & PACKING MATERIALS			

	1-473-519-11	REMOTE COMMANDER (RM-DC41) (C260Z/CE315)	
	1-558-271-11	CORD, CONNECTION (AUDIO)108cm	
	3-859-177-11	MANUAL, INSTRUCTION (ENGLISH) (US,UK,AUS)	
	3-859-177-21	MANUAL, INSTRUCTION (ENGLISH/FRENCH/SPANISH/PORTUGUESE/CHINESE) (CND,AEP,E,SP)	
	3-859-177-31	MANUAL, INSTRUCTION (GERMAN/DUTCH/ITALIAN/SWEDISH)(AEP,AED)	
	3-859-177-41	MANUAL, INSTRUCTION (DANISH/FINNISH) (AED)	
	3-859-177-51	MANUAL, INSTRUCTION (ENGLISH/POLISH/RUSSIAN)(EE,CIS)	
	4-941-762-11	COVER (MLY), BATTERY (C260Z/CE315)	

Ref. No.	Part No.	Description	Remarks

		HARDWARE LIST	

#1	7-685-647-79	SCREW +BVTP 3X10 TYPE2 N-S	
#2	7-685-872-09	SCREW +BVTT 3X8 (S)	
#3	7-685-648-79	SCREW (M3X12), TAPPING	
#4	7-685-646-79	SCREW +BVTP 3X8 TYPE2 N-S	
#5	7-621-772-00	SCREW +B 2X3	
#6	7-685-134-19	SCREW (+ PTPWH) (2.6X8)	
#7	7-621-255-15	SCREW +P 2X3	
#8	7-685-871-01	SCREW +BVTT 3X6 (S)	

<p>The components identified by mark △ or dotted line with mark △ are critical for safety. Replace only with part number specified.</p>	<p>Les composants identifiés par une marque △ sont critiques pour la sécurité. Ne les remplacer que par une pièce portant le numéro spécifié.</p>
---	---