

# CDP-C311M

## SERVICE MANUAL

AEP Model  
UK Model

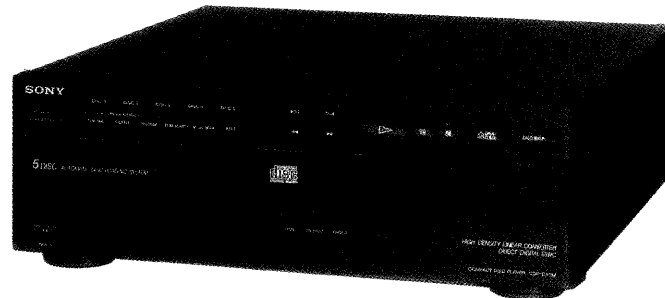

Model Name Using Similar Mechanism	CDP-C75ES/C85ES/C705
CD Transport Mechanism Type	CDM16G1-5BD3
Optical Pick-Up Block Type	BU-5BD3

### SPECIFICATIONS

System	Compact disc digital audio system
Laser	Semiconductor laser ( $\lambda = 780 \text{ nm}$ ) Emission duration: continuous
Laser output	Max. $44.6 \mu\text{W}^*$ * This output is the value measured at a distance of about 200 mm from the objective lens surface on the Optical Pick-up Block.
Frequency response	2 Hz – 20 kHz ( $\pm 0.5 \text{ dB}$ )
Signal to noise ratio	More than 100 dB
Dynamic range	More than 98 dB
Harmonic distortion	Less than 0.005% (1 kHz)
Channel separation	More than 100 dB (1 kHz)
Wow and flutter	Below measurable limit
Outputs LINE OUT (phono jacks)	Output level 2 V (at 50 kilohms) Load impedance over 10 kilohms

### General

Power requirements	UK model: 240 V AC, 50/60 Hz AEP model: 220–230 V AC, 50/60 Hz
Power consumption	12 W
Dimensions (not including projecting parts and controls)	Approx. 355 × 120 × 385 mm (w/h/d) (14 × 4¾ × 15¼ inches)
Weight	Approx. 4.9 kg (10 lbs 13 oz)

### Supplied accessories

Audio signal connecting cord	1 (phono plug × 2 ↔ phono plug × 2)
------------------------------	--

Design and specifications subject to change without notice.

COMPACT DISC PLAYER  
**SONY**®

CLASS 1 LASER PRODUCT  
 LUOKAN 1 LASERLAITE  
 KLASSE 1 LASERAPPARAT

This Compact Disc player is classified as a CLASS 1 LASER product.  
 The CLASS 1 LASER PRODUCT label is located on the rear exterior.

#### NOTES ON HANDLING THE OPTICAL PICK-UP BLOCK OR BASE UNIT

The laser diode in the optical pick-up block may suffer electrostatic breakdown because of the potential difference generated by the charged electrostatic load, etc. on clothing and the human body.



During repair, pay attention to electrostatic breakdown and also use the procedure in the printed matter which is included in the repair parts.

The flexible board is easily damaged and should be handled with care.

#### NOTES ON LASER DIODE EMISSION CHECK

The laser beam on this model is concentrated so as to be focused on the disc reflective surface by the objective lens in the optical pick-up block. Therefore, when checking the laser diode emission, observe from more than 30cm away from the objective lens.

#### SAFETY-RELATED COMPONENT WARNING!!

COMPONENTS IDENTIFIED BY MARK  OR DOTTED LINE WITH MARK  ON THE SCHEMATIC DIAGRAMS AND IN THE PARTS LIST ARE CRITICAL TO SAFE OPERATION. REPLACE THESE COMPONENTS WITH SONY PARTS WHOSE PART NUMBERS APPEAR AS SHOWN IN THIS MANUAL OR IN SUPPLEMENTS PUBLISHED BY SONY.

## Note on the Transit Key

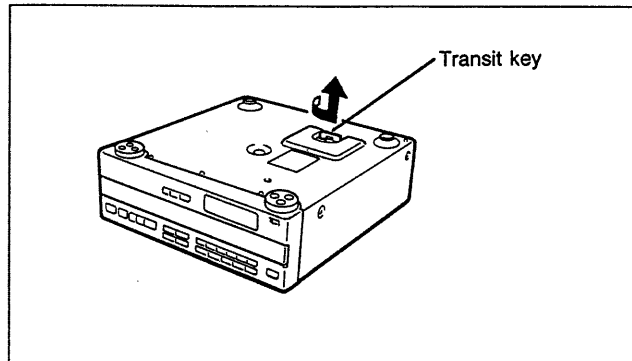

The transit key on the bottom exterior of the unit protects the optical system against shock during transportation. Before operating the CD player, be sure to remove the key by following the instructions on the label, and store it in a safe place.

When transporting the unit, replace the key in its original hole and lock it in place.

## PROTECTION OF EYES FROM LASER BEAM DURING SERVICING

This set employs a laser. Therefore, be sure to follow carefully the instructions below when servicing.

### CAUTION

Use of controls or adjustments or performance of procedures other than those specified herein may result in hazardous radiation exposure.

#### 1. Laser Diode Properties

- Material: GaAlAs
  - Wavelength: 780 nm
  - Emission Duration: continuous
  - Laser Output Power: less than 44.6  $\mu\text{W}$ \*
- \* This output is the value measured at a distance of 200 mm from the objective lens surface on the Optical Pick-up Block.

2. During service, do not take the Optical Pick-up Block apart, and do not adjust the APC circuit. If there is a breakdown in the APC circuit (including laser diode), replace the entire Optical Pick-up Block (including APC board).

## BESKYTTELSE AF ØJNE MOD LASERSTRÅLING UNDER SERVICE

I dette apparat anvendes laserlys. Derfor skal nedenstående instruktioner nøje følges under service.

Følg iøvrigt instruktionerne i servicemanualen.

### ADVARSEL!!

Under service må øjnene ikke komme nær objektiv-linsen på den optiske pick-up enhed. I tilfælde af at det er nødvendigt at kontrollere udsendelsen af laserlys, skal det ske i en afstand af mere end 25 cm fra den optiske pick-up.

#### 1. Laser-dioe data

- Materiale: GaAlAs
  - Bølgelængde: 780 nm
  - Udstråling: Kontinuerlig
  - Laseroutput: Max. 0,4 mW\*
- \* Målt i 1,6 mm afstand fra overfladen af objektiv-linsen på den optiske pick-up enhed.
- Klassifikation: Klasse IIIb.

2. Adskil aldrig den optiske pick-up enhed under service, og juster ikke APC kredsløbet (Automatic Power Control). Hvis APC kredsløbet (incl. laser-dioden) bryder ned, skal hele den optiske pick-up enhed (incl. APC printkortet) udskiftes.

## LASER ADVARSEL MÆRKNING

Følgende mærkning findes indvendig i apparatet:

#### 1. Advarsel Mærkning

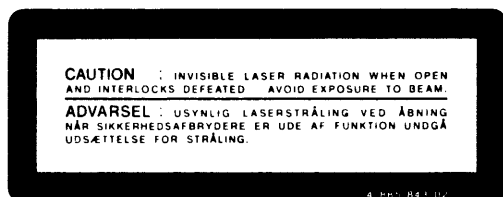

**VAROITUS:** Laite sisältää, laserdiodin, joka lähettää (näkyvätöntä) silmille vaarallista lasersäteilyä.

## SECTION 1 GENERAL

### 1-1. LOCATION AND CONTROL

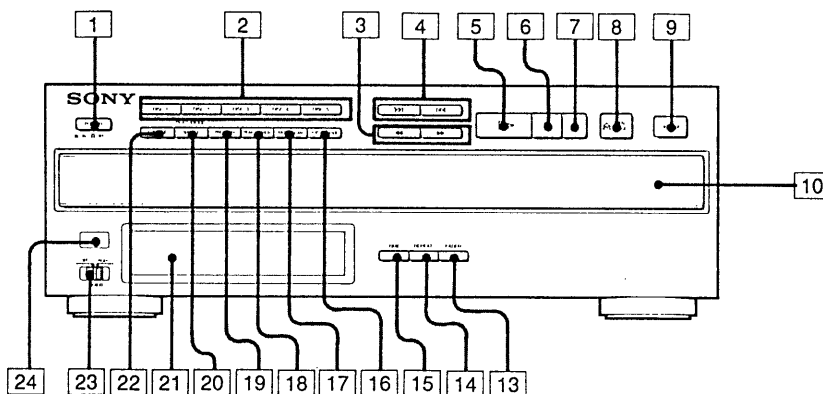

- 1 POWER switch
- 2 DISC 1-5 buttons
- 3 ◀▶ (manual search) buttons
- 4 ◀▶▶▶ (AMS\*) buttons
- 5 ▶ (play) button
- 6 || (pause) button
- 7 ■ (stop) button
- 8 ▲ OPEN/CLOSE button
- 9 DISC SKIP button
- 10 Disc tray
- 13 FADER button
- 14 REPEAT button
- 15 TIME button
- 16 EDIT/TIME FADE button
- 17 MUSIC SCAN button
- 18 PEAK SEARCH button
- 19 PROGRAM button
- 20 SHUFFLE button
- 21 Display window
- 22 CONTINUE button
- 23 TIMER switch
- 24 Remote sensor

\* AMS is the abbreviation of Automatic Music Sensor.

## SECTION 2 ELECTRICAL BLOCK CHECKING

**Note :**

1. CD Block basically constructed to operate without adjustment. Therefore, check each item in order given.
2. Use YEDS-18 disc (3-702-101-01) unless otherwise indicated.
3. Use the oscilloscope with more than 10MΩ impedance.
4. Clean an object lens by an applicator with neutral detergent when the signal level is low than specified value with the following checks.

**S Curve Check**

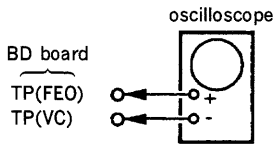

**Procedure :**

1. Connect oscilloscope to test point TP (FEO) on BD board.
2. Connect between test point TP (FES) and TP (VC) by lead wire.
3. Turned Power switch on and actuate the focus search. (actuate the focus search when disc table is moving in and out.)
4. Check the oscilloscope waveform (S curve) is symmetrical between A and B. And confirm peak to peak level within  $3 \pm 1V_{p-p}$ .

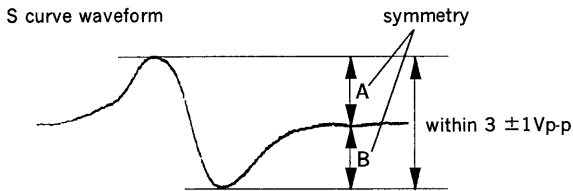

5. After check, remove the lead wire connected in step 2.
- Note :**
- Try to measure several times to make sure that the ratio of A : B or B : A is more than 10 : 7.
  - Take sweep time as long as possible and light up the brightness to obtain best waveform.

**RF Level Check**

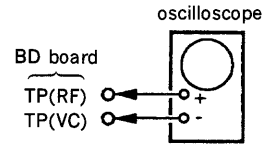

**Procedure :**

1. Connect oscilloscope to test point TP (RF) on BD board.
2. Turn Power switch on.
3. Put disc (YEDS-18) in and playback.
4. Confirm that oscilloscope waveform is clear and check RF signal level is correct or not.

**Note :**

Clear RF signal waveform means that the shape “◇” can be clearly distinguished at the center of the waveform.

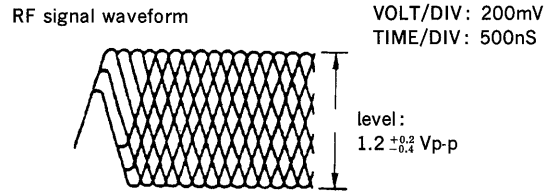

**E-F Balance Check**

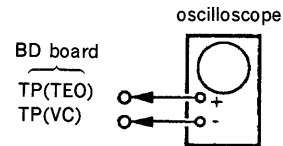

**Procedure :**

1. Connect test point TP (AFJ) to ground and TP (TES) to TP (VC) with lead wire.
2. Connect oscilloscope to test point TP (TEO) on BD board.
3. Turn Power switch on.
4. Put disc (YEDS-18) in and playback.
5. Confirm that the oscilloscope waveform is symmetrical on the top and bottom in relation to 0V, and check this level.

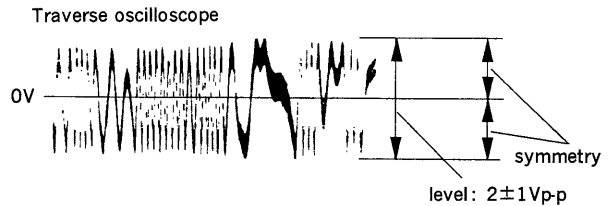

6. Remove the lead wire connected in step 1.

## RF PLL Free-run Frequency Check

### Procedure :

1. Connect frequency counter to test point (PCK) with lead wire.

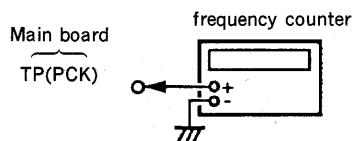

2. Turn Power switch on.
3. Confirm that reading on frequency counter is 4.3218MHz.

### Focus/Tracking Gain

This gain has a margin, so even if it is slightly off.

There is no problem.

Therefore, do not perform, this adjustment.

Please note that it should be fixed to mechanical center position when you moved and do not know original position.

### Adjustment Locations :

[BD board]

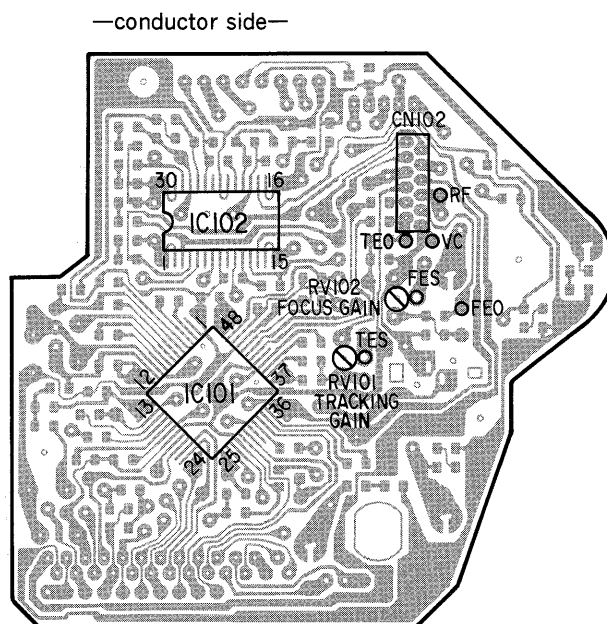

[MAIN board]

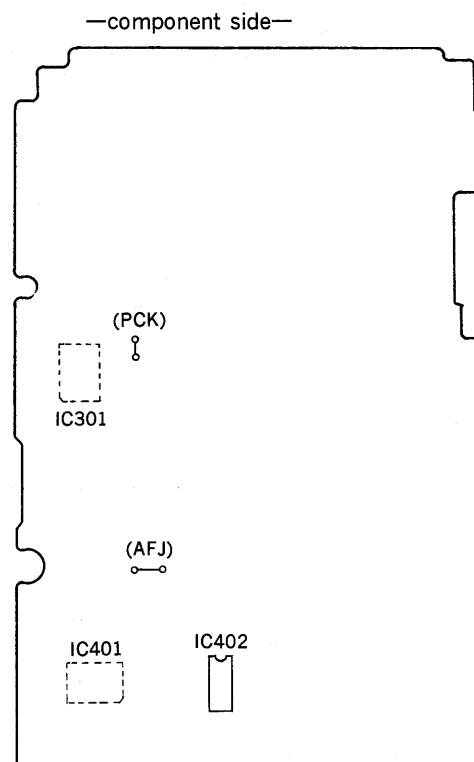

# SECTION 3 DIAGRAMS

## 3-1. CIRCUIT BOARDS LOCATION

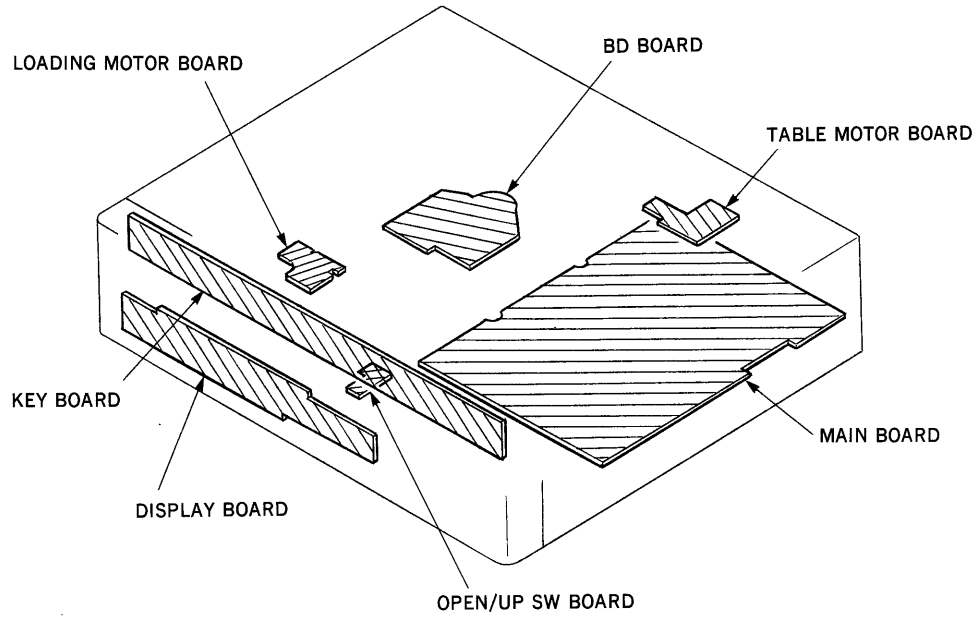

## 3-2. SEMICONDUCTOR LEAD LAYOUTS

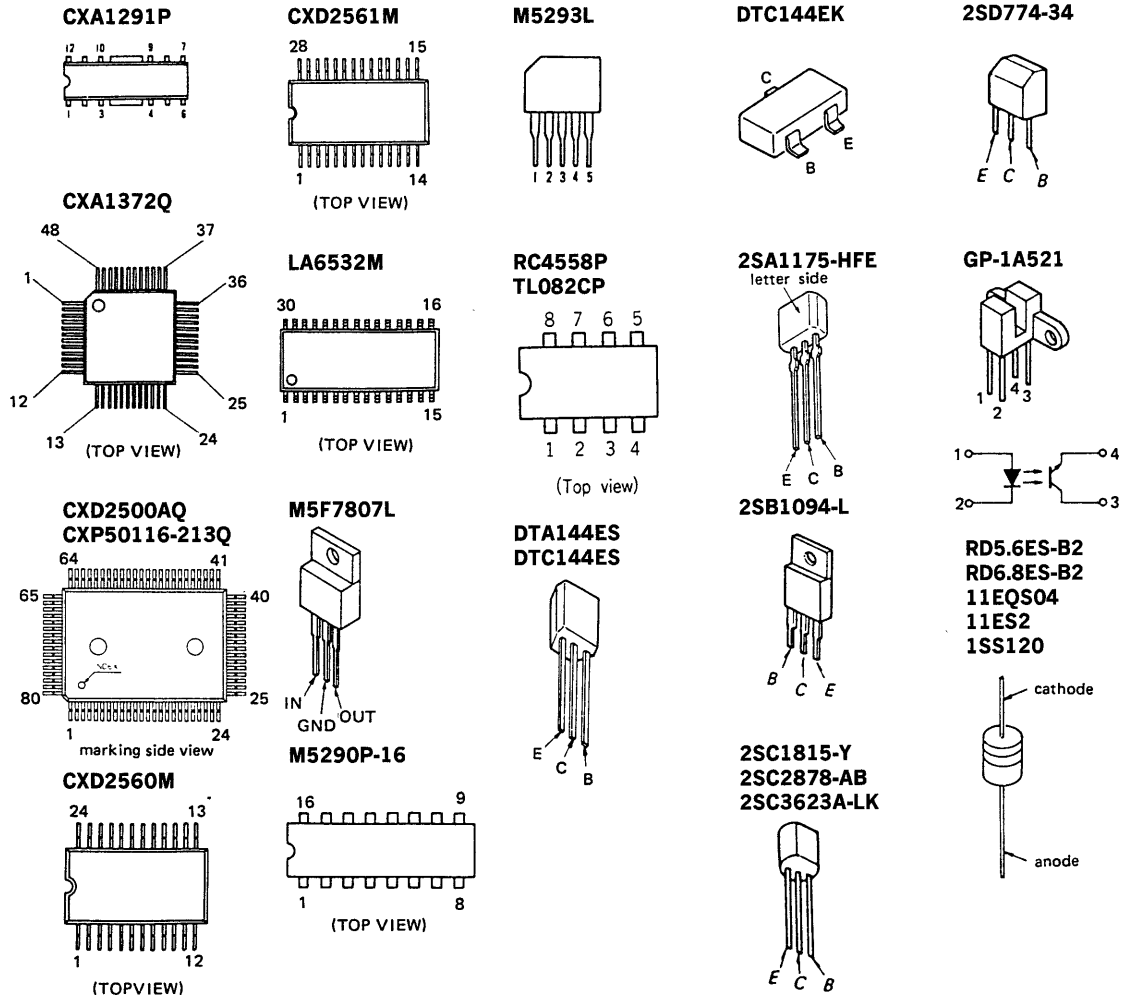

• Semiconductor Location

Ref. No.	Location
D201	C-5
D202	C-5
D203	G-6
D204	G-5
D205	F-6
D206	G-6
D208	G-10
D209	G-11
D341	D-8
D351	D-8
D701	A-18
IC101	C-20
IC102	B-20
IC201	B-5
IC202	E-6
IC203	F-9
IC204	D-5
IC301	B-8
IC302	C-7
IC303	E-8
IC306	E-11
IC307	E-12
IC401	B-13
IC402	D-13
IC551	I-15
Q101	D-21
Q201	B-5
Q202	F-6
Q203	G-7
Q204	E-7
Q205	F-7
Q206	F-7
Q209	F-9
Q341	F-13
Q342	F-13
Q343	E-13
Q344	D-9
Q371	E-12
Q372	F-12
Q373	E-12
Q374	F-12
Q375	E-12
Q376	F-12
Q401	C-13

3-3. PRINTED WIRING BOARDS

• Refer to Page 7 for Semiconductor Lead Layouts

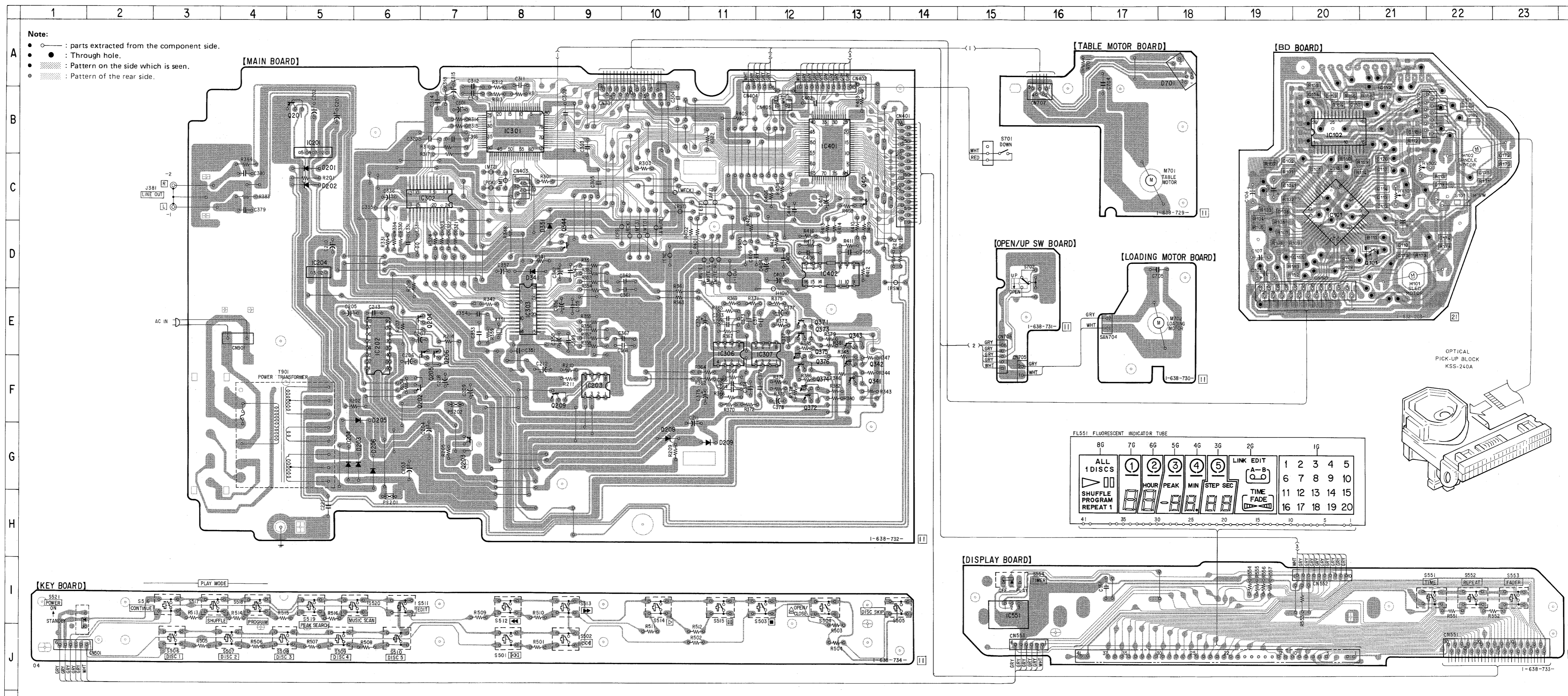



3-4. SCHEMATIC DIAGRAM

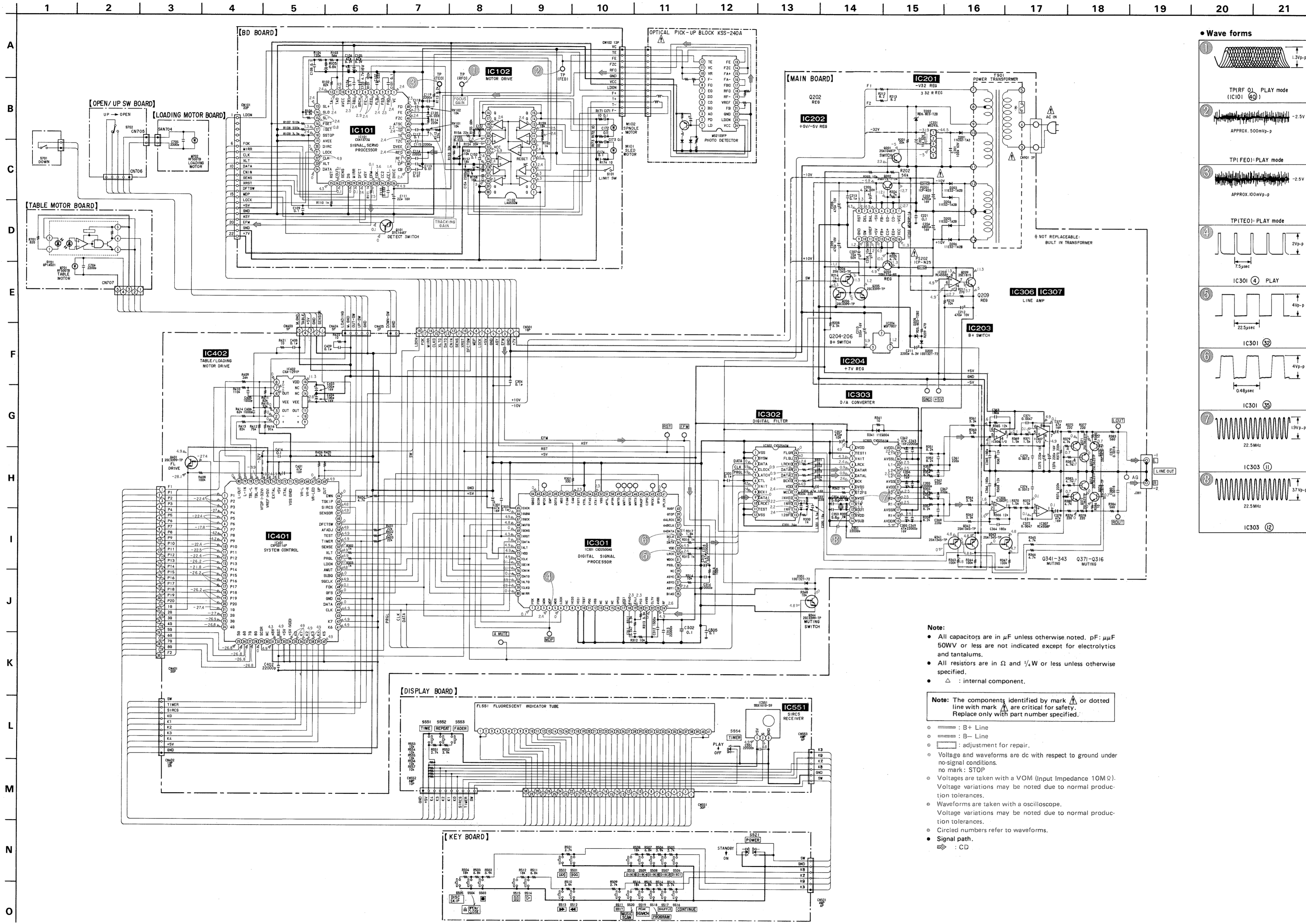

• IC Block Diagrams  
IC101 CXA1372Q

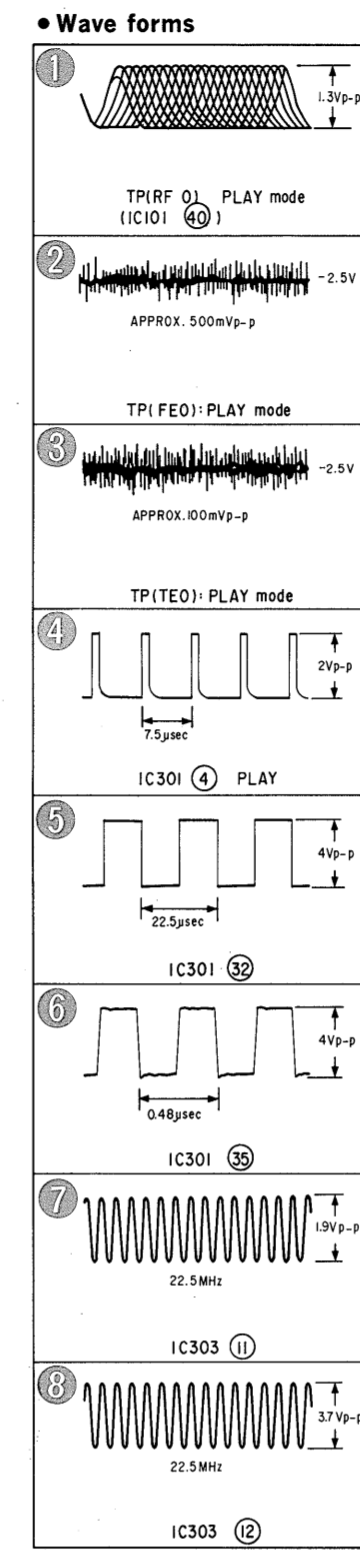
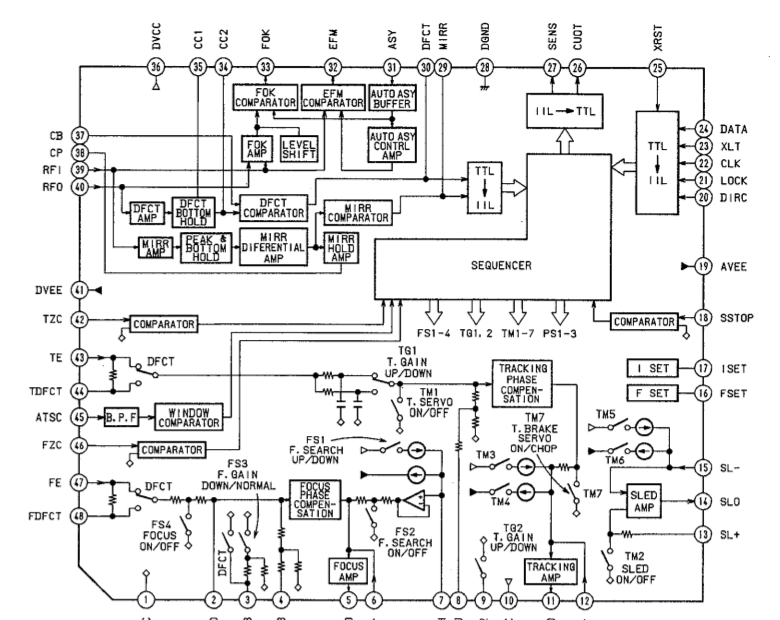

IC301 CXD2500AQ

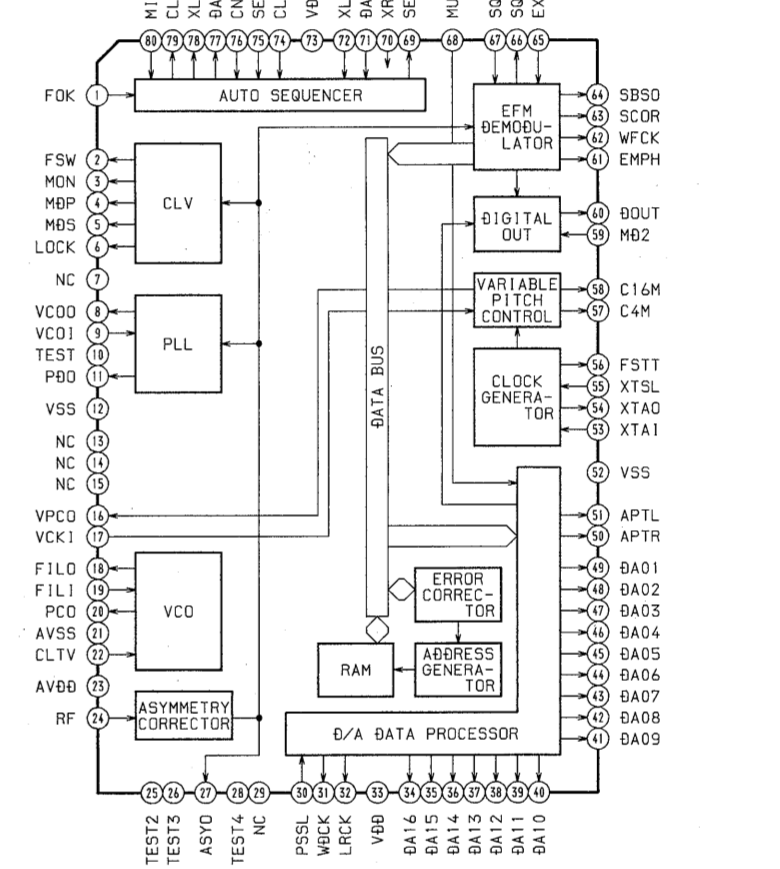

IC202 M5290P

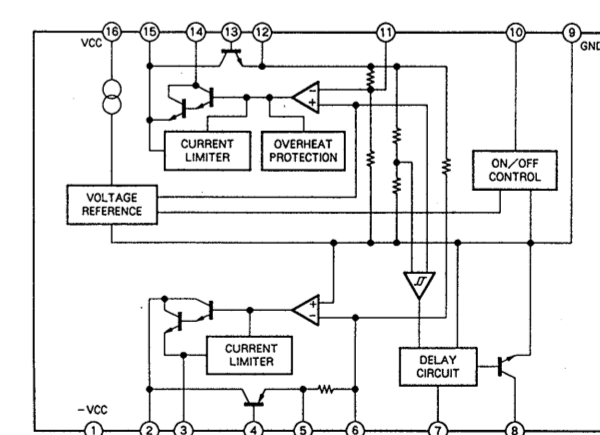

IC402 CXA1291P

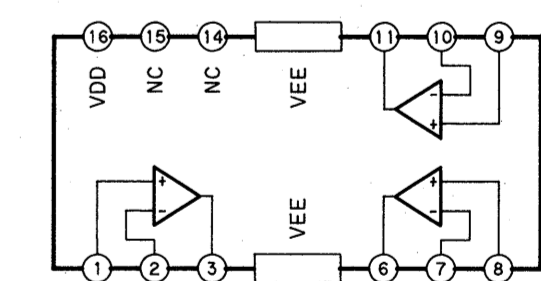

IC201 M5293L

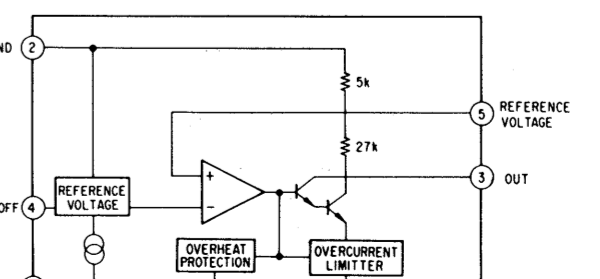

Note:  
 • All capacitors are in  $\mu F$  unless otherwise noted. pF:  $\mu\mu F$  50WV or less are not indicated except for electrolytics and tantalums.  
 • All resistors are in  $\Omega$  and  $1/4 W$  or less unless otherwise specified.  
 •  $\Delta$ : internal component.

Note: The components identified by mark  $\Delta$  or dotted line with mark  $\Delta$  are critical for safety. Replace only with part number specified.

- : B+ Line
- ◐ : B- Line
- ◑ : adjustment for repair.
- : Voltage and waveforms are dc with respect to ground under no-signal conditions. no mark: STOP
- : Voltages are taken with a VOM (Input Impedance 10M $\Omega$ ). Voltage variations may be noted due to normal production tolerances.
- : Waveforms are taken with an oscilloscope. Voltage variations may be noted due to normal production tolerances.
- : Circled numbers refer to waveforms.
- Signal path
- ◑ : CD

# SECTION 4 EXPLODED VIEWS

**NOTE:**

- The mechanical parts with no reference number in the exploded views are not supplied.
- Items marked "\*" are not stocked since they are seldom required for routine service. Some delay should be anticipated when ordering these items.

- -XX, -X mean standardized parts, so they may have some differences from the original one.

- Color Indication of Appearance Parts  
Example:  
KNOB, BALANCE (WHITE)...(RED)

Parts Color      Cabinet's Color

- Hardware (# mark) list is given in the last of this parts list.

The components identified by mark or dotted line with mark are critical for safety. Replace only with part number specified.

**4-1. CABINET ASSEMBLY**

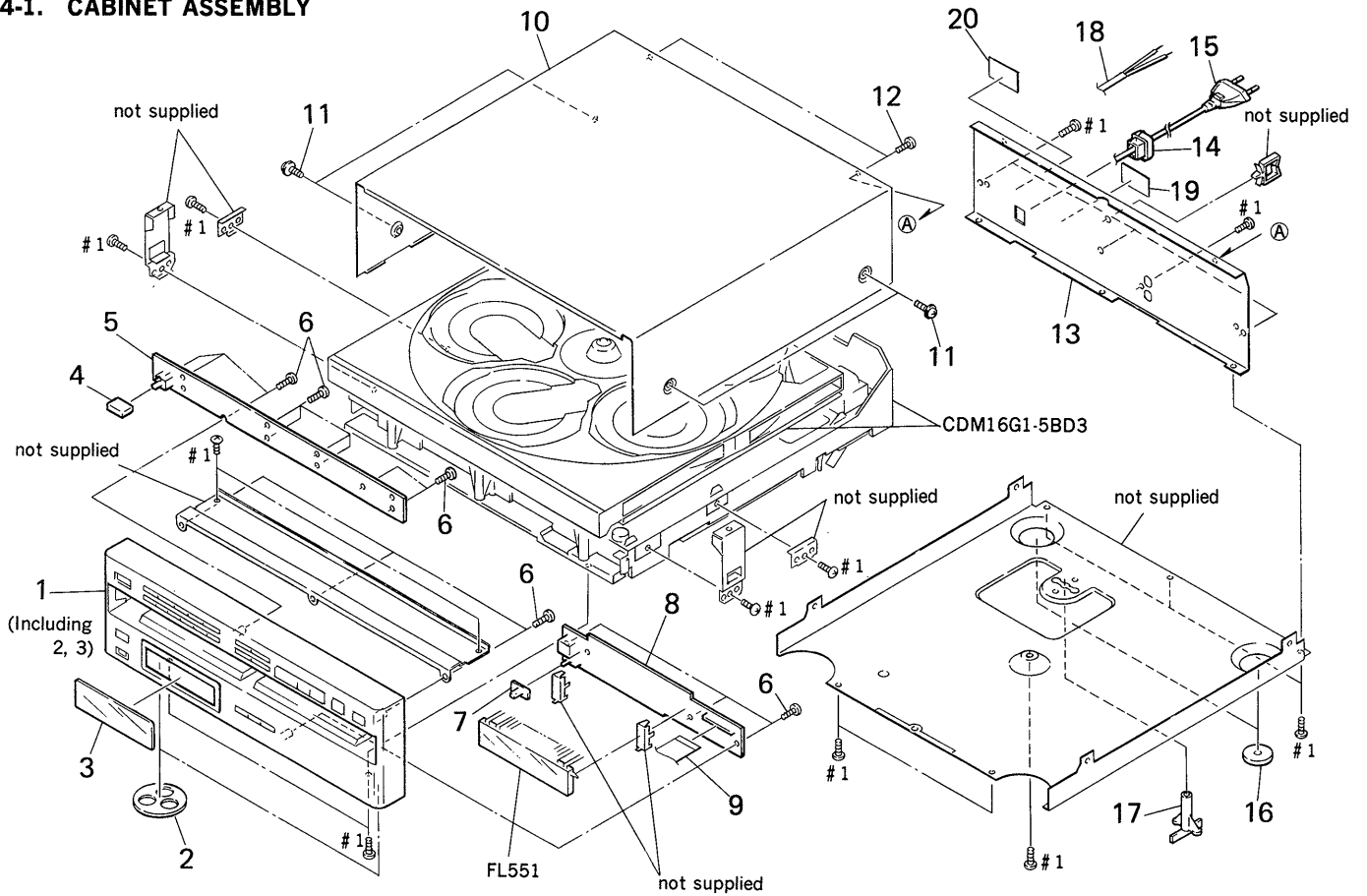

Ref. No.	Part No.	Description	Remark
1	X-4941-459-1	PANEL ASSY, FRONT	
2	4-921-906-01	FELT	
3	4-943-987-01	PLATE, INDICATION (AEP)	
4	4-927-341-01	BUTTON (POWER)	
5	* 1-638-734-11	KEY BOARD	
6	4-928-635-01	SCREW, +BV (2.6X8) TAPPING	
7	4-922-518-01	KNOB (TIMER)	
8	* 1-638-733-11	DISPLAY BOARD	
9	1-590-905-11	WIRE, FLAT TYPE (30 CORE)	
10	* 4-943-992-11	CASE	
11	3-704-366-01	SCREW (CASE) (M3X8)	
12	3-703-685-21	SCREW (+BV 3X8)	

Ref. No.	Part No.	Description	Remark
13	* 4-943-120-41	PANEL, BACK (AEP)	
13	* 4-943-120-51	PANEL, BACK (UK)	
14	* 3-703-244-00	BUSHING (2104), CORD	
15	1-575-651-21	CORD, POWER (AEP)	
16	4-924-410-01	FELT	
17	4-937-945-01	PLATE (TRANSPORT), LOCK	
18	1-558-946-21	CORD, POWER (UK)	
19	* 4-941-548-01	LABEL, CLASS 1 (AEP)	
20	* 4-941-548-01	LABEL, CLASS 1 (UK)	
FL551	1-519-655-21	FLUORESCENT INDICATOR	

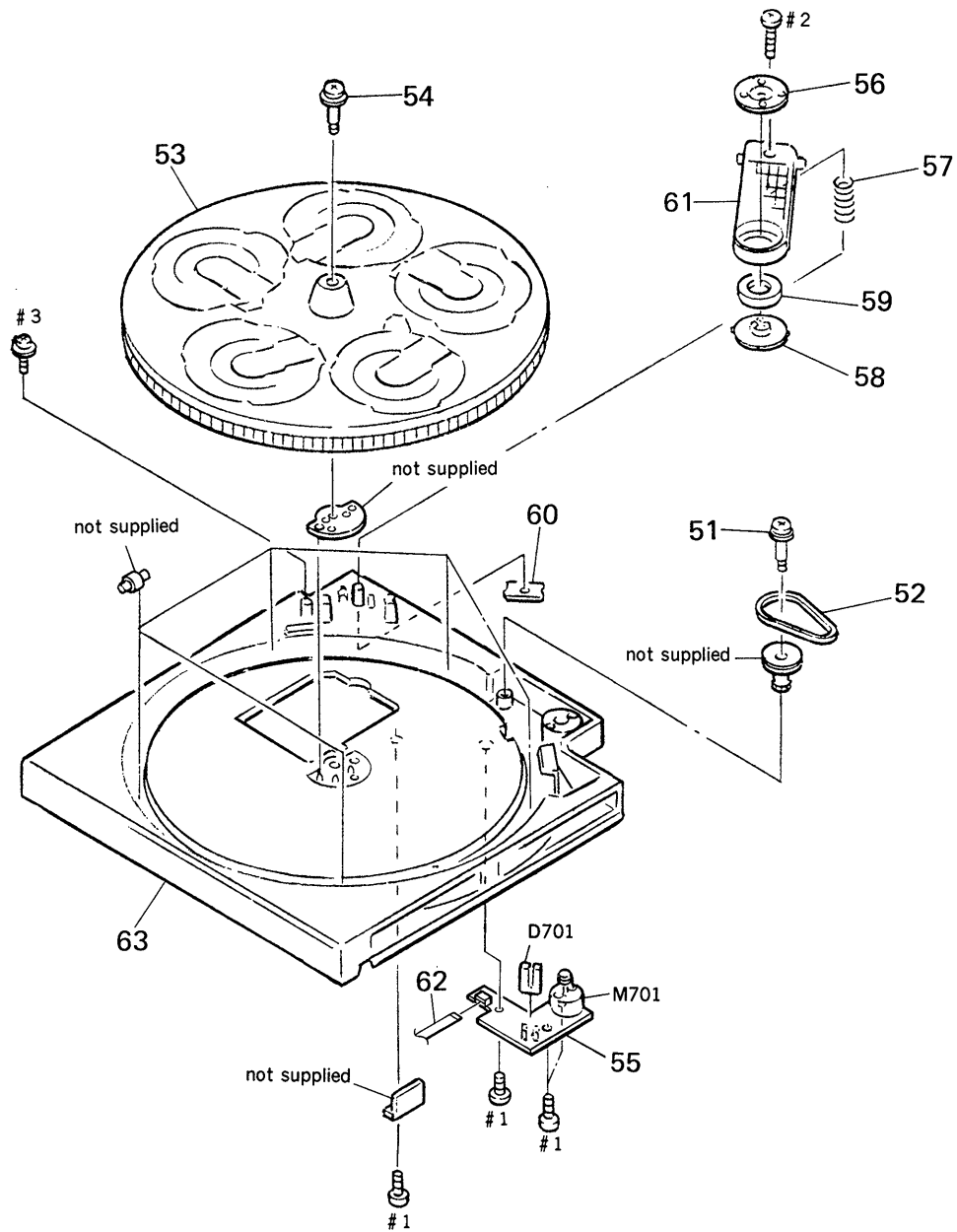

## 4-2. TRAY ASSEMBLY

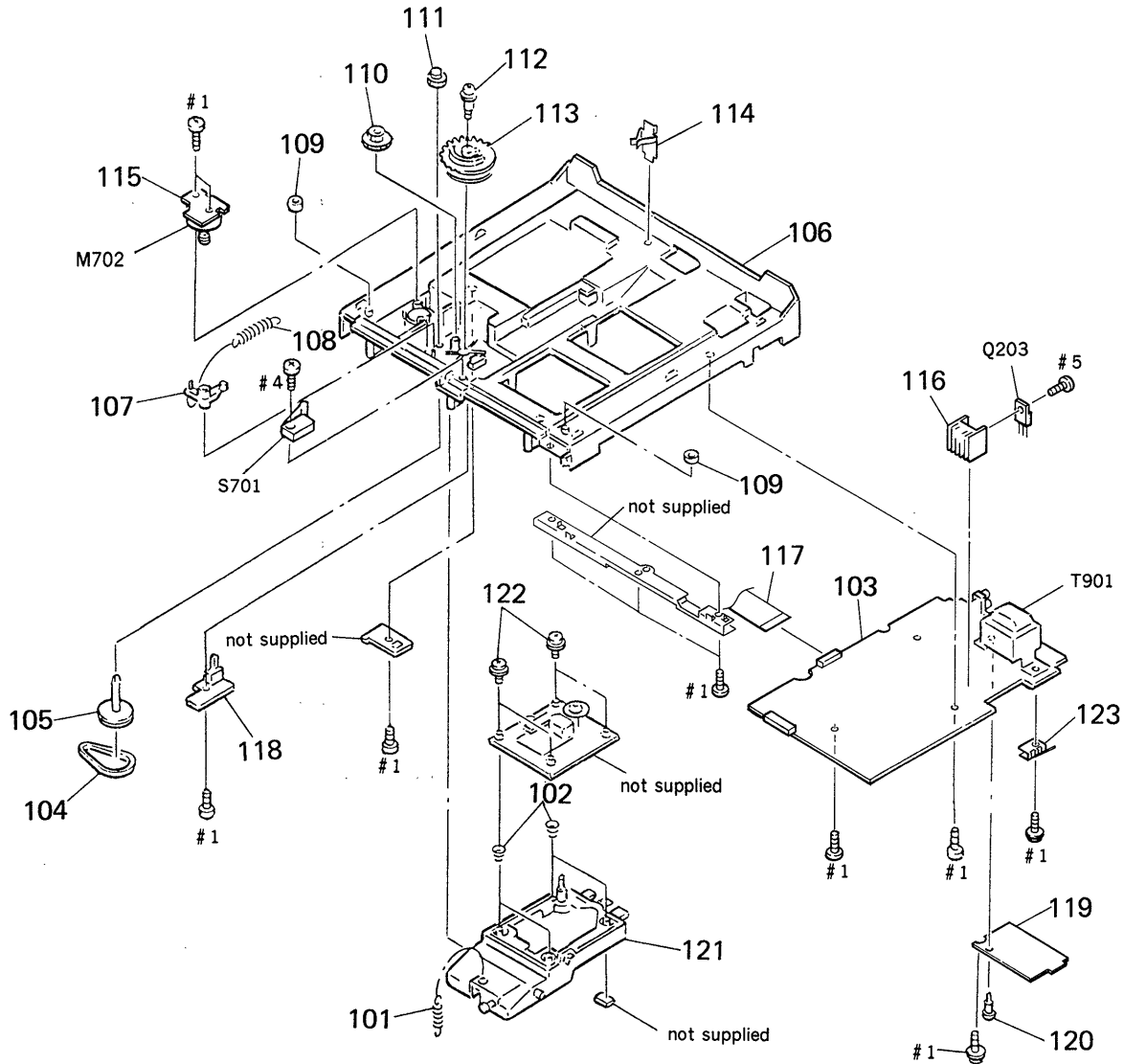

Ref. No.	Part No.	Description	Remark	Ref. No.	Part No.	Description	Remark
51	4-923-597-01	SCREW, STEP		59	1-452-340-21	MAGNET	
52	4-926-399-01	BELT		60	* 4-926-388-01	BRACKET (ADJUSTMENT)	
53	* 4-926-383-02	TABLE (B), DISK		61	* 4-930-506-02	BRACKET (PRESS PULLEY)	
54	4-926-384-01	SCREW, STEP		62	1-590-849-11	WIRE, FLAT TYPE (5 CORE)	
55	* 1-638-729-11	TABLE MOTOR BOARD		63	4-943-986-01	TABLE (A), DISK	
56	4-921-029-01	YOKE, CHUCKING		D701	8-719-970-19	DIODE GP-1A521	
57	4-926-395-01	SPRING, COMPRESSION		M701	A-4604-585-A	MOTOR ASSY, ROTARY	
58	4-921-022-01	PULLEY, CHUCKING					

### 4-3. CHASSIS ASSEMBLY



**Note:** The components identified by mark  or dotted line with mark  are critical for safety. Replace only with part number specified.

Ref. No.	Part No.	Description	Remark
101	4-937-911-01	SPRING, TENSION	
102	4-917-541-01	SPRING (B)	
103	* A-4617-785-A	MAIN BOARD, COMPLETE	
104	4-944-490-01	BELT (TIMING)	
105	X-4941-529-1	PULLEY ASSY	
106	* 4-943-997-01	CHASSIS	
107	4-917-519-01	LEVER, SET	
108	4-924-412-01	SPRING (B), TENSION	
109	* 4-934-382-01	CUSHION	
110	4-934-381-01	GEAR (LOADING C)	
111	4-934-375-01	GEAR (LOADING B)	
112	4-926-317-01	SCREW, STEP	
113	4-934-391-01	GEAR (LOADING A)	
114	* 4-943-996-01	SPRING, LEAF	

Ref. No.	Part No.	Description	Remark
115	* 1-638-730-11	LOADING MOTOR BOARD	
116	* 4-363-146-21	HEAT SINK, V. OUT	
117	1-535-892-11	JUMPER, FILM (WITH TERMINAL)	
118	* 1-638-731-11	OPEN/UP SW BOARD	
119	* 4-944-178-01	SHEET (INSULATING)	
120	3-531-576-11	RIVET	
121	* 4-934-373-01	BRACKET (BU)	
122	4-933-134-01	SCREW (+PTPWH M2. 6X6)	
123	* 4-944-581-01	PLATE, GROUND	
M702	A-4604-834-A	MOTOR ASSY, LOADING	
Q203	8-729-111-67	TRANSISTOR 2SB1094-L	
S701	1-572-713-11	SWITCH, PUSH (WITH CONNECTOR) (DOWN)	
T901	 1-449-955-11	TRANSFORMER, POWER	

#### 4-4. OPTICAL PICK-UP BLOCK (BU-5BD3)

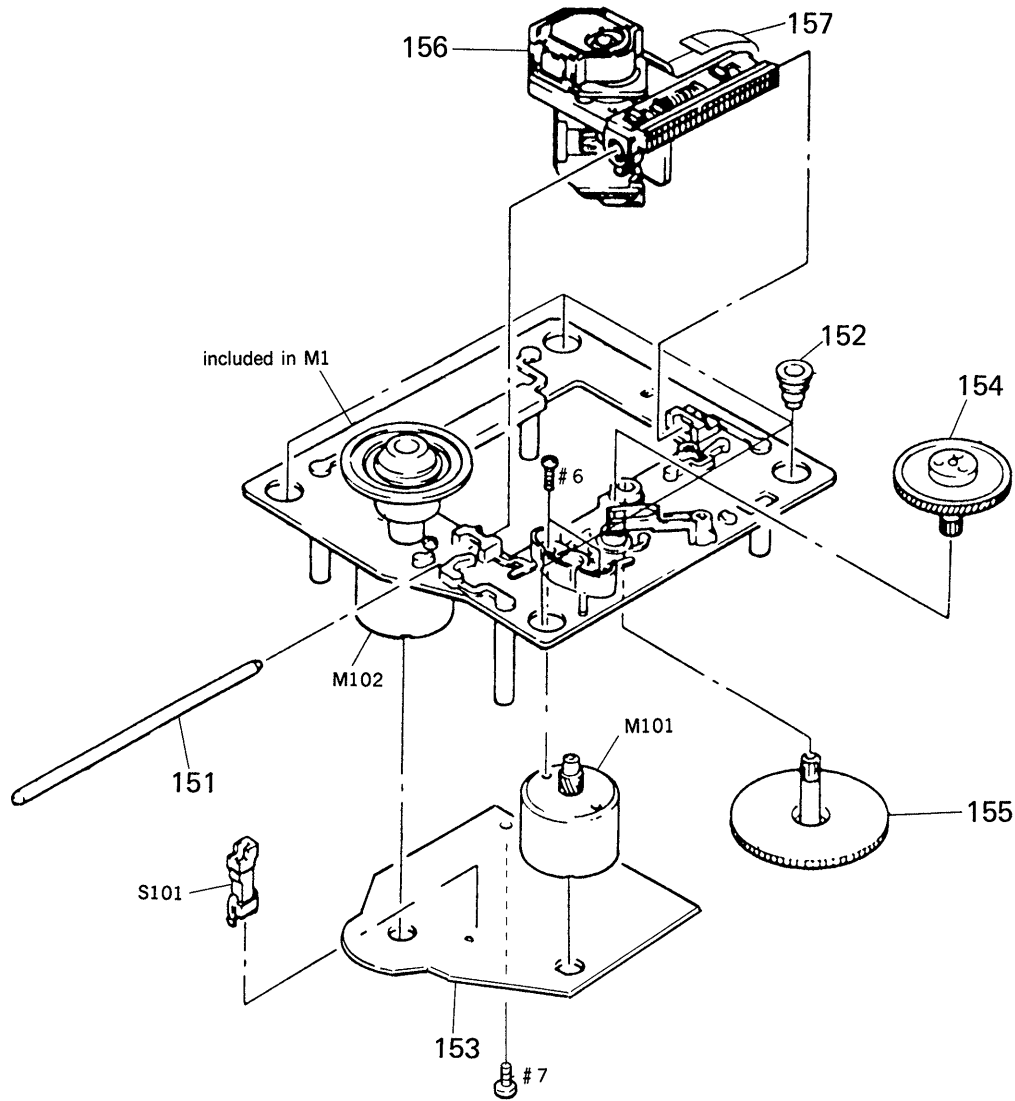

**Note:** The components identified by mark  $\triangle$  or dotted line with mark  $\triangle$  are critical for safety. Replace only with part number specified.

Ref. No.	Part No.	Description	Remark	Ref. No.	Part No.	Description	Remark
151	4-917-565-01	SHAFT, SLED		156	$\triangle$ 8-848-144-11	DEVICE, OPTICAL KSS-240A	
152	4-933-126-01	INSULATOR (A)		157	1-575-001-11	WIRE, FLAT TYPE (12 CORE)	
153	* A-4617-371-A	BD BOARD, COMPLETE		M101	X-4917-504-1	MOTOR ASSY, SLED	
154	4-917-567-01	GEAR (M)		M102	X-4917-523-3	MOTOR ASSY, SPINDLE	
155	4-917-564-01	GEAR (P), FLATNESS		S101	1-572-085-11	SWITCH, LEAF (LIMIT)	

## SECTION 5 ELECTRICAL PARTS LIST

BD

**NOTE:**

- Due to standardization, replacements in the parts list may be different from the parts specified in the diagrams or the components used on the set.
- Items marked "\*" are not stocked since they are seldom required for routine service. Some delay should be anticipated when ordering these items.
- -XX, -X mean standardized parts, so they may have some differences from the original one.
- CAPACITORS  
uF:  $\mu$ F

- RESISTORS  
All resistors are in ohms  
METAL: Metal-film resistor  
METAL OXIDE: Metal Oxide-film resistor  
F: nonflammable
- COILS  
uH:  $\mu$ H
- SEMICONDUCTORS  
In each case, u:  $\mu$ , for example:  
uA...:  $\mu$ A..., uPA...:  $\mu$ PA...,  
uPB...:  $\mu$ PB..., uPC...:  $\mu$ PC...,  
uPD...:  $\mu$ PD....

The components identified by mark  $\Delta$  or dotted line with mark  $\Delta$  are critical for safety. Replace only with part number specified.

When indicating parts by reference number, please include the board name.

Ref. No.	Part No.	Description	Remark	Ref. No.	Part No.	Description	Remark
	* A-4617-371-A	BD BOARD, COMPLETE *****				< CONNECTOR >	
		< CAPACITOR >					
C101	1-163-038-00	CERAMIC CHIP 0.1uF	25V			< IC >	
C102	1-163-989-11	CERAMIC CHIP 0.033uF	10% 25V				
C103	1-126-163-11	ELECT 4.7uF	20% 50V	IC101	8-752-050-82	IC CXA1372Q	
C104	1-163-038-00	CERAMIC CHIP 0.1uF	25V	IC102	8-759-821-94	IC LA6532M	
C105	1-126-154-11	ELECT 47uF	20% 6.3V				
C106	1-126-154-11	ELECT 47uF	20% 6.3V	J101	1-216-295-00	METAL CHIP 0	5% 1/10W
C107	1-126-154-11	ELECT 47uF	20% 6.3V	J102	1-216-295-00	METAL CHIP 0	5% 1/10W
C108	1-163-038-00	CERAMIC CHIP 0.1uF	25V			< TRANSISTOR >	
C109	1-163-038-00	CERAMIC CHIP 0.1uF	25V				
C110	1-163-989-11	CERAMIC CHIP 0.033uF	10% 25V	Q101	8-729-901-01	TRANSISTOR DTC144EK	
C111	1-131-367-00	TANTALUM 22uF	10% 20V			< RESISTOR >	
C112	1-164-232-11	CERAMIC CHIP 0.01uF	50V	R101	1-216-097-00	METAL CHIP 100K	5% 1/10W
C113	1-164-232-11	CERAMIC CHIP 0.01uF	50V	R102	1-216-095-00	METAL CHIP 82K	5% 1/10W
C114	1-164-161-11	CERAMIC CHIP 0.0022uF	10% 100V	R103	1-216-091-00	METAL CHIP 56K	5% 1/10W
C115	1-164-161-11	CERAMIC CHIP 0.0022uF	10% 100V	R104	1-216-099-00	METAL CHIP 120K	5% 1/10W
C117	1-163-038-00	CERAMIC CHIP 0.1uF	25V	R105	1-216-069-00	METAL CHIP 6.8K	5% 1/10W
C118	1-163-038-00	CERAMIC CHIP 0.1uF	25V	R106	1-216-061-00	METAL CHIP 3.3K	5% 1/10W
C119	1-164-161-11	CERAMIC CHIP 0.0022uF	10% 100V	R107	1-216-114-00	METAL GLAZE 510K	5% 1/10W
C120	1-163-989-11	CERAMIC CHIP 0.033uF	10% 25V	R108	1-216-105-00	METAL CHIP 220K	5% 1/10W
C151	1-163-019-00	CERAMIC CHIP 0.0068uF	10% 50V	R109	1-216-061-00	METAL CHIP 3.3K	5% 1/10W
C152	1-163-038-00	CERAMIC CHIP 0.1uF	25V	R110	1-216-049-00	METAL CHIP 1K	5% 1/10W
C153	1-163-006-11	CERAMIC CHIP 560PF	10% 50V	R111	1-216-049-00	METAL CHIP 1K	5% 1/10W
C154	1-164-161-11	CERAMIC CHIP 0.0022uF	10% 100V	R112	1-216-083-00	METAL CHIP 27K	5% 1/10W
C155	1-163-023-00	CERAMIC CHIP 0.015uF	5% 50V	R113	1-216-071-00	METAL CHIP 8.2K	5% 1/10W
C171	1-163-038-00	CERAMIC CHIP 0.1uF	25V	R114	1-216-105-00	METAL CHIP 220K	5% 1/10W
C172	1-163-038-00	CERAMIC CHIP 0.1uF	25V	R152	1-216-073-00	METAL CHIP 10K	5% 1/10W
C173	1-163-038-00	CERAMIC CHIP 0.1uF	25V				
C174	1-163-038-00	CERAMIC CHIP 0.1uF	25V				

**BD MAIN, DISPLAY, KEY**

Ref. No.	Part No.	Description	Remark
R153	1-216-085-00	METAL CHIP 33K	5% 1/10W
R154	1-216-085-00	METAL CHIP 33K	5% 1/10W
R155	1-216-093-00	METAL CHIP 68K	5% 1/10W
R156	1-216-081-00	METAL CHIP 22K	5% 1/10W
R157	1-216-079-00	METAL CHIP 18K	5% 1/10W
R158	1-216-079-00	METAL CHIP 18K	5% 1/10W
R159	1-216-079-00	METAL CHIP 18K	5% 1/10W
R160	1-216-049-00	METAL CHIP 1K	5% 1/10W
R171	1-216-001-00	METAL CHIP 10	5% 1/10W
R172	1-216-001-00	METAL CHIP 10	5% 1/10W
R173	1-216-001-00	METAL CHIP 10	5% 1/10W
R174	1-216-001-00	METAL CHIP 10	5% 1/10W
< VARIABLE RESISTOR >			
RV101	1-238-016-11	RES. ADJ. CARBON 10K	
RV102	1-238-016-11	RES. ADJ. CARBON 10K	
< SWITCH >			
S101	1-572-085-11	SWITCH, LEAF (LIMIT)	
*****			
*A-4617-785-A MAIN BOARD, COMPLETE			
*****			
* 1-638-733-11 DISPLAY BOARD			
* 1-638-734-11 KEY BOARD			
* 4-363-146-21 HEAT SINK, V. OUT			
7-682-548-09 SCREW +BVTT 3X8 (S)			
< CAPACITOR >			
C201	1-124-572-11	ELECT 100uF	20% 63V
C202	1-126-059-11	ELECT 10uF	20% 50V
C203	1-126-937-11	ELECT 4700uF	20% 16V
C204	1-126-017-11	ELECT 6800uF	20% 16V
C205	1-126-163-11	ELECT 4.7uF	20% 50V
C206	1-126-059-11	ELECT 10uF	20% 50V
C207	1-126-059-11	ELECT 10uF	20% 50V
C208	1-124-997-11	ELECT 470uF	20% 10V
C209	1-124-997-11	ELECT 470uF	20% 10V
C210	1-126-024-11	ELECT 220uF	20% 16V
C211	1-124-893-11	ELECT 2200uF	20% 10V
C212	1-124-997-11	ELECT 470uF	20% 10V
C213	1-164-159-11	CERAMIC 0.1uF	50V
C221	1-164-159-11	CERAMIC 0.1uF	50V
C301	1-126-022-11	ELECT 47uF	20% 16V
C302	1-164-159-11	CERAMIC 0.1uF	50V
C303	1-164-159-11	CERAMIC 0.1uF	50V
C304	1-164-159-11	CERAMIC 0.1uF	50V
C305	1-164-159-11	CERAMIC 0.1uF	50V

Ref. No.	Part No.	Description	Remark
C311	1-136-161-00	METALIZED FILM 0.047uF	5% 50V
C312	1-161-374-11	CERAMIC 0.0015uF	20% 50V
C313	1-161-494-00	CERAMIC 0.022uF	25V
C314	1-162-306-11	CERAMIC 0.01uF	20% 16V
C315	1-126-300-11	ELECT 0.47uF	20% 50V
C316	1-161-494-00	CERAMIC 0.022uF	25V
C320	1-164-159-11	CERAMIC 0.1uF	50V
C331	1-162-208-31	CERAMIC 24PF	5% 50V
C335	1-162-205-31	CERAMIC 18PF	5% 50V
C336	1-126-022-11	ELECT 47uF	20% 16V
C342	1-126-022-11	ELECT 47uF	20% 16V
C343	1-161-494-00	CERAMIC 0.022uF	25V
C349	1-161-494-00	CERAMIC 0.022uF	25V
C350	1-126-022-11	ELECT 47uF	20% 16V
C351	1-161-494-00	CERAMIC 0.022uF	25V
C353	1-162-196-31	CERAMIC 5.6PF	10% 50V
C354	1-162-196-31	CERAMIC 5.6PF	10% 50V
C355	1-161-494-00	CERAMIC 0.022uF	25V
C356	1-126-022-11	ELECT 47uF	20% 16V
C357	1-124-997-11	ELECT 470uF	20% 10V
C361	1-162-286-31	CERAMIC 220PF	10% 50V
C362	1-162-286-31	CERAMIC 220PF	10% 50V
C363	1-162-285-31	CERAMIC 180PF	10% 50V
C364	1-162-285-31	CERAMIC 180PF	10% 50V
C365	1-162-285-31	CERAMIC 180PF	10% 50V
C366	1-162-285-31	CERAMIC 180PF	10% 50V
C367	1-162-286-31	CERAMIC 220PF	10% 50V
C368	1-162-286-31	CERAMIC 220PF	10% 50V
C371	1-130-479-00	MYLAR 0.0047uF	5% 50V
C372	1-130-479-00	MYLAR 0.0047uF	5% 50V
C373	1-130-472-00	MYLAR 0.0012uF	5% 50V
C374	1-130-472-00	MYLAR 0.0012uF	5% 50V
C375	1-126-024-11	ELECT 220uF	20% 16V
C376	1-126-024-11	ELECT 220uF	20% 16V
C377	1-126-022-11	ELECT 47uF	20% 16V
C378	1-126-022-11	ELECT 47uF	20% 16V
C379	1-130-474-00	MYLAR 0.0018uF	5% 50V
C380	1-130-474-00	MYLAR 0.0018uF	5% 50V
C401	1-126-022-11	ELECT 47uF	20% 16V
C402	1-161-494-00	CERAMIC 0.022uF	25V
C403	1-126-023-11	ELECT 100uF	20% 16V
C404	1-126-023-11	ELECT 100uF	20% 16V
C405	1-162-294-31	CERAMIC 0.001uF	10% 50V
C406	1-162-294-31	CERAMIC 0.001uF	10% 50V
C408	1-164-159-11	CERAMIC 0.1uF	50V
C409	1-164-159-11	CERAMIC 0.1uF	50V
C414	1-164-159-11	CERAMIC 0.1uF	50V
C551	1-161-494-00	CERAMIC 0.022uF	25V

## MAIN, DISPLAY, KEY

Ref. No.	Part No.	Description	Remark	Ref. No.	Part No.	Description	Remark
< CONNECTOR >				< TRANSISTOR >			
CN301	* 1-573-046-11	SOCKET, CONNECTOR 18P		Q201	8-729-119-76	TRANSISTOR 2SA1175-HFE	
CN401	* 1-573-045-11	SOCKET, CONNECTOR 30P		Q202	8-729-140-96	TRANSISTOR 2SD774-34	
CN402	* 1-568-948-11	PIN, CONNECTOR 10P		Q203	8-729-111-67	TRANSISTOR 2SB1094-L	
CN403	* 1-568-824-11	SOCKET, CONNECTOR 5P		Q204	8-729-900-65	TRANSISTOR DTA144ES	
CN404	* 1-568-943-11	PIN, CONNECTOR 5P		Q205	8-729-900-89	TRANSISTOR DTC144ES	
CN551	* 1-568-933-21	SOCKET, CONNECTOR 30P		Q206	8-729-900-89	TRANSISTOR DTC144ES	
CN901	* 1-573-047-11	PIN, CONNECTOR		Q209	8-729-281-52	TRANSISTOR 2SC1815-Y	
< DIODE >				Q341	8-729-900-65	TRANSISTOR DTA144ES	
D201	8-719-200-82	DIODE 11ES2		Q342	8-729-900-65	TRANSISTOR DTA144ES	
D202	8-719-109-97	DIODE RD6. 8ES-B2		Q343	8-729-900-65	TRANSISTOR DTA144ES	
D203	8-719-200-82	DIODE 11ES2		Q344	8-729-900-89	TRANSISTOR DTC144ES	
D204	8-719-200-82	DIODE 11ES2		Q371	8-729-141-30	TRANSISTOR 2SC3623A-LK	
D205	8-719-200-82	DIODE 11ES2		Q372	8-729-141-30	TRANSISTOR 2SC3623A-LK	
D206	8-719-200-82	DIODE 11ES2		Q373	8-729-141-30	TRANSISTOR 2SC3623A-LK	
D208	8-719-109-89	DIODE RD5. 6ES-B2		Q374	8-729-141-30	TRANSISTOR 2SC3623A-LK	
D209	8-719-912-20	DIODE 1SS120		Q375	8-729-231-55	TRANSISTOR 2SC2878-AB	
D341	8-719-210-21	DIODE 11EQS04		Q376	8-729-231-55	TRANSISTOR 2SC2878-AB	
D351	8-719-912-20	DIODE 1SS120		Q401	8-729-900-89	TRANSISTOR DTC144ES	
< FILTER >				< RESISTOR >			
FL551	1-519-655-21	FLUORESCENT INDICATOR		R201	1-249-435-11	CARBON 33K 5% 1/4W	
< IC >				R202	1-249-438-11	CARBON 56K 5% 1/4W	
IC201	8-759-633-42	IC M5293L		R203	1-249-429-11	CARBON 10K 5% 1/4W	
IC202	8-759-630-21	IC M5290P-16		R204	1-249-425-11	CARBON 4.7K 5% 1/4W	
IC203	8-759-945-58	IC RC4558P		R205	1-249-425-11	CARBON 4.7K 5% 1/4W	
IC204	8-759-604-86	IC M5F7807L		R208	1-249-423-11	CARBON 3.3K 5% 1/4W	
IC301	8-752-337-26	IC CXD2500AQ		R209	1-249-413-11	CARBON 470 5% 1/4W	
IC302	8-752-342-65	IC CXD2560M		R210	1-249-429-11	CARBON 10K 5% 1/4W	
IC303	8-752-343-01	IC CXD2561M		R211	1-249-410-11	CARBON 270 5% 1/4W	
IC306	8-759-990-82	IC TL082CP		R212	1-249-392-11	CARBON 8.2 5% 1/4W	
IC307	8-759-945-58	IC RC4558P		R213	1-249-392-11	CARBON 8.2 5% 1/4W	
IC401	8-752-817-42	IC CXP50116-213Q		R214	1-249-417-11	CARBON 1K 5% 1/4W	
IC402	8-752-035-28	IC CXA1291P		R301	1-249-411-11	CARBON 330 5% 1/4W	
IC551	8-741-100-48	IC SBX1610-59		R302	1-249-417-11	CARBON 1K 5% 1/4W	
< JACK >				R303	1-249-417-11	CARBON 1K 5% 1/4W	
J381	1-569-442-11	JACK, PIN 2P (LINE OUT)		R311	1-249-423-11	CARBON 3.3K 5% 1/4W	
< COIL >				R312	1-249-429-11	CARBON 10K 5% 1/4W	
L331	1-408-403-00	INDUCTOR 3.3uH		R313	1-249-423-11	CARBON 3.3K 5% 1/4W	
PS201	△ 1-532-685-00	LINK, IC		R314	1-249-429-11	CARBON 10K 5% 1/4W	
PS202	△ 1-532-637-00	LINK, IC 1.0A		R315	1-249-417-11	CARBON 1K 5% 1/4W	

**Note:** The components identified by mark  $\Delta$  or dotted line with mark  $\Delta$  are critical for safety. Replace only with part number specified.



## MAIN, DISPLAY, KEY

Ref. No.	Part No.	Description	Remark	Ref. No.	Part No.	Description	Remark
R323	1-249-417-11	CARBON	1K 5% 1/4W	R402	1-249-433-11	CARBON	22K 5% 1/4W
R324	1-249-418-11	CARBON	1.2K 5% 1/4W	R403	1-249-433-11	CARBON	22K 5% 1/4W
R330	1-249-417-11	CARBON	1K 5% 1/4W	R404	1-249-425-11	CARBON	4.7K 5% 1/4W
R331	1-249-409-11	CARBON	220 5% 1/4W	R405	1-249-425-11	CARBON	4.7K 5% 1/4W
R334	1-249-409-11	CARBON	220 5% 1/4W	R406	1-249-425-11	CARBON	4.7K 5% 1/4W
R341	1-249-393-11	CARBON	10 5% 1/4W	R408	1-249-441-11	CARBON	100K 5% 1/4W
R342	1-249-417-11	CARBON	1K 5% 1/4W	R409	1-247-864-11	CARBON	24K 5% 1/4W
R343	1-249-441-11	CARBON	100K 5% 1/4W	R410	1-247-880-11	CARBON	110K 5% 1/4W
R344	1-249-441-11	CARBON	100K 5% 1/4W	R411	1-249-440-11	CARBON	82K 5% 1/4W
R345	1-249-425-11	CARBON	4.7K 5% 1/4W	R412	1-247-876-11	CARBON	75K 5% 1/4W
R346	1-249-425-11	CARBON	4.7K 5% 1/4W	R413	1-249-440-11	CARBON	82K 5% 1/4W
R347	1-249-441-11	CARBON	100K 5% 1/4W	R414	1-247-874-11	CARBON	62K 5% 1/4W
R348	1-249-429-11	CARBON	10K 5% 1/4W	R415	1-249-435-11	CARBON	33K 5% 1/4W
R351	1-249-428-11	CARBON	8.2K 5% 1/4W	R416	1-247-878-00	CARBON	91K 5% 1/4W
R352	1-249-428-11	CARBON	8.2K 5% 1/4W	R421	1-249-393-11	CARBON	10 5% 1/4W
R353	1-249-428-11	CARBON	8.2K 5% 1/4W	R422	1-249-393-11	CARBON	10 5% 1/4W
R354	1-249-428-11	CARBON	8.2K 5% 1/4W	R501	1-249-422-11	CARBON	2.7K 5% 1/4W
R355	1-249-428-11	CARBON	8.2K 5% 1/4W	R502	1-249-424-11	CARBON	3.9K 5% 1/4W
R356	1-249-428-11	CARBON	8.2K 5% 1/4W	R503	1-249-427-11	CARBON	6.8K 5% 1/4W
R357	1-249-428-11	CARBON	8.2K 5% 1/4W	R504	1-249-432-11	CARBON	18K 5% 1/4W
R358	1-249-428-11	CARBON	8.2K 5% 1/4W	R505	1-249-422-11	CARBON	2.7K 5% 1/4W
R359	1-247-903-00	CARBON	1M 5% 1/4W	R506	1-249-424-11	CARBON	3.9K 5% 1/4W
R361	1-249-423-11	CARBON	3.3K 5% 1/4W	R507	1-249-427-11	CARBON	6.8K 5% 1/4W
R362	1-249-423-11	CARBON	3.3K 5% 1/4W	R508	1-249-432-11	CARBON	18K 5% 1/4W
R363	1-249-423-11	CARBON	3.3K 5% 1/4W	R509	1-249-422-11	CARBON	2.7K 5% 1/4W
R364	1-249-423-11	CARBON	3.3K 5% 1/4W	R510	1-249-424-11	CARBON	3.9K 5% 1/4W
R365	1-249-430-11	CARBON	12K 5% 1/4W	R511	1-249-427-11	CARBON	6.8K 5% 1/4W
R366	1-249-430-11	CARBON	12K 5% 1/4W	R512	1-249-432-11	CARBON	18K 5% 1/4W
R367	1-249-430-11	CARBON	12K 5% 1/4W	R513	1-249-422-11	CARBON	2.7K 5% 1/4W
R368	1-249-430-11	CARBON	12K 5% 1/4W	R514	1-249-424-11	CARBON	3.9K 5% 1/4W
R369	1-249-419-11	CARBON	1.5K 5% 1/4W	R515	1-249-427-11	CARBON	6.8K 5% 1/4W
R370	1-249-419-11	CARBON	1.5K 5% 1/4W	R516	1-249-432-11	CARBON	18K 5% 1/4W
R371	1-249-419-11	CARBON	1.5K 5% 1/4W	R551	1-249-422-11	CARBON	2.7K 5% 1/4W
R372	1-249-419-11	CARBON	1.5K 5% 1/4W	R552	1-249-424-11	CARBON	3.9K 5% 1/4W
R373	1-247-887-00	CARBON	220K 5% 1/4W	R553	1-249-429-11	CARBON	10K 5% 1/4W
R374	1-247-887-00	CARBON	220K 5% 1/4W	R554	1-249-429-11	CARBON	10K 5% 1/4W
R375	1-249-409-11	CARBON	220 5% 1/4W	R555	1-249-429-11	CARBON	10K 5% 1/4W
R376	1-249-409-11	CARBON	220 5% 1/4W	R556	1-249-429-11	CARBON	10K 5% 1/4W
R377	1-249-409-11	CARBON	220 5% 1/4W	R557	1-249-429-11	CARBON	10K 5% 1/4W
R378	1-249-409-11	CARBON	220 5% 1/4W				
R379	1-249-425-11	CARBON	4.7K 5% 1/4W				
R380	1-249-425-11	CARBON	4.7K 5% 1/4W				
R381	1-249-425-11	CARBON	4.7K 5% 1/4W				
R382	1-249-425-11	CARBON	4.7K 5% 1/4W				
R383	1-249-414-11	CARBON	560 5% 1/4W				
R384	1-249-414-11	CARBON	560 5% 1/4W				
R385	1-249-393-11	CARBON	10 5% 1/4W				
R386	1-249-393-11	CARBON	10 5% 1/4W				
R401	1-249-433-11	CARBON	22K 5% 1/4W				

&lt; SWITCH &gt;

S501	1-554-303-21	SWITCH, TACTILE (⏏)
S502	1-554-303-21	SWITCH, TACTILE (⏏)
S503	1-554-303-21	SWITCH, TACTILE (■)
S504	1-554-303-21	SWITCH, TACTILE (OPEN/CLOSE)
S505	1-554-303-21	SWITCH, TACTILE (DISC SKIP)
S506	1-554-303-21	SWITCH, TACTILE (DISC 1)
S507	1-554-303-21	SWITCH, TACTILE (DISC 2)
S508	1-554-303-21	SWITCH, TACTILE (DISC 3)

**MAIN, DISPLAY, KEY**

**TABLE MOTOR, LOADING MOTOR, OPEN/UP SW**

Ref. No.	Part No.	Description	Remark
S509	1-554-303-21	SWITCH, TACTILE (DISC 4)	
S510	1-554-303-21	SWITCH, TACTILE (DISC 5)	
S511	1-554-303-21	SWITCH, TACTILE (EDIT)	
S512	1-554-303-21	SWITCH, TACTILE (◀◀)	
S513	1-554-303-21	SWITCH, TACTILE (▶▶)	
S514	1-554-303-21	SWITCH, TACTILE (▷ )	
S515	1-554-303-21	SWITCH, TACTILE (□□ )	
S516	1-554-303-21	SWITCH, TACTILE (CONTINUE)	
S517	1-554-303-21	SWITCH, TACTILE (SHUFFLE)	
S518	1-554-303-21	SWITCH, TACTILE (PROGRAM)	
S519	1-554-303-21	SWITCH, TACTILE (PEAK SEARCH)	
S520	1-554-303-21	SWITCH, TACTILE (MUSIC SCAN)	
S521	1-572-714-11	SWITCH, PUSH (POWER)	
S551	1-554-303-21	SWITCH, TACTILE (TIME)	
S552	1-554-303-21	SWITCH, TACTILE (REPEAT)	
S553	1-554-303-21	SWITCH, TACTILE (FADER)	
S554	1-570-157-51	SWITCH, SLIDE (TIMER)	
		< CRYSTAL >	
X351	1-567-965-11	VIBRATOR, CRYSTAL (22.5MHz)	
*****			
	* 1-638-729-11	TABLE MOTOR BOARD	*****
	* 1-638-730-11	LOADING MOTOR BOARD	
	* 1-638-731-11	OPEN/UP SW BOARD	
		< CAPACITOR >	
C704	1-161-375-00	CERAMIC 0.0022uF 20% 50V	
C705	1-161-375-00	CERAMIC 0.0022uF 20% 50V	
		< CONNECTOR >	
CN705	* 1-566-214-11	PIN, CONNECTOR (PC BOARD) 2P	
CN707	* 1-573-044-11	SOCKET, CONNECTOR	
		< DIODE >	
D701	8-719-970-19	DIODE GP-1A521	
		< RESISTOR >	
R701	1-249-416-11	CARBON 820 5% 1/4W	
		< SWITCH >	
S702	1-571-300-21	SWITCH, ROTARY (OPEN/UP)	

Ref. No.	Part No.	Description	Remark
		MISCELLANEOUS	
		*****	
	1-590-905-11	WIRE, FLAT TYPE (30 CORE)	
△	1-575-651-21	CORD, POWER (AEP)	
△	1-558-946-21	CORD, POWER (UK)	
	1-452-340-21	MAGNET	
	1-590-849-11	WIRE, FLAT TYPE (5 CORE)	
	1-535-892-11	JUMPER, FILM (WITH TERMINAL)	
△	8-848-144-11	DEVICE, OPTICAL KSS-240A	
	1-575-001-11	WIRE, FLAT TYPE (12 CORE)	
FL551	1-519-655-21	FLUORESCENT INDICATOR	
M101	X-4917-504-1	MOTOR ASSY, SLED	
M102	X-4917-523-3	MOTOR ASSY, SPINDLE	
M701	A-4604-585-A	MOTOR ASSY, ROTARY	
M702	A-4604-834-A	MOTOR ASSY, LOADING	
S701	1-572-713-11	SWITCH, PUSH (WITH CONNECTOR) (DOWN)	
T901	△ 1-449-955-11	TRANSFORMER, POWER	
*****			
		ACCESSORY & PACKING MATERIAL	
	3-753-030-11	MANUAL, INSTRUCTION	
		(ENGLISH, FRENCH, SPANISH, PORTUGUESE)	
	3-753-030-41	MANUAL, INSTRUCTION (AEP)	
		(GERMAN, DUTCH, SWEDISH, ITALIAN)	
	* 3-795-629-11	INSTRUCTION (AEP)	
	* 4-944-039-01	INDIVIDUAL CARTON	
	* 4-944-040-01	CUSHION (FRONT)	
	* 4-944-041-01	CUSHION (REAR)	
*****			
		<b>HARDWARE LIST</b>	
# 1	7-685-647-79	SCREW +BVTP 3X10 TYPE2 N-S	
# 2	7-682-554-04	SCREW +B 3X25	
# 3	7-685-648-79	SCREW (M3X12), TAPPING	
# 4	7-685-136-19	SCREW +P 2.6X12 TYPE2 NON-SLIT	
# 5	7-682-548-09	SCREW +BVTT 3X8 (S)	
# 6	7-621-255-15	SCREW +P 2X3	
# 7	7-685-134-19	SCREW +BTP 2.6X8 TYPE2 N-S	

**Note:** The components identified by mark △ or dotted line with mark △ are critical for safety. Replace only with part number specified.

