

# CDP-C313M/C315M

## SERVICE MANUAL

*AEP Model*  
*E Model*  
*Australian Model*  
 CDP-C315  
*UK Model*  
 CDP-C313



Model Name Using Similar Mechanism	CDP-C311M
CD Mechanism Type	CDM16H1-5BD3
Optical Pick-Up Block Type	BU-5BD3

### SPECIFICATIONS

	CDP-C315M/C313M
System	Compact disc digital audio system
Laser	Semiconductor laser ( $\lambda = 780 \text{ nm}$ ) Emission duration: continuous
Laser output	Max. $44.6 \mu\text{W}^*$ * This output is the value measured at a distance of about 200 mm from the objective lens surface on the Optical Pick-up Block.
Frequency response	2 Hz – 20 kHz ( $\pm 0.5 \text{ dB}$ )
Signal to noise ratio	More than 100 dB
Dynamic range	More than 98 dB
Harmonic distortion	Less than 0.005% (1 kHz)
Channel separation	More than 100 dB (1 kHz)
Wow and flutter	Below measurable limit
Outputs LINE OUT (phono jacks)	Output level 2 V (at 50 kilohms) Load impedance over 10 kilohms
HEADPHONES (stereo phone jack)	Output level 0 – 10 mW (variable) (at 32 ohms)

#### General

Power requirements	UK Model 240 V AC, 50/60 Hz AEP, AUS Model 220 – 230 V AC, 50/60 Hz E Model 110 – 120 or 220 – 240 V AC adjustable, 50/60 Hz
Power consumption	12 W
Dimensions (not including projecting parts and controls)	Approx. 355 × 120 × 385 mm (w/h/d) (14 × 4 $\frac{3}{4}$ × 15 $\frac{1}{4}$ inches)
Weight	Approx. 4.9 kg (10 lbs 13 oz)

#### Supplied accessories

	CDP-C315M/C313M
Audio signal connecting cord	1 (phono plug × 2 ↔ phono plug × 2)
Remote commander	1 (RM-D315)
R6 (size AA) batteries	2

Design and specifications subject to change without notice.

COMPACT DISC PLAYER  
**SONY**<sup>®</sup>

For the United Kingdom  
and European Countries

CLASS 1 LASER PRODUCT  
LUOKAN 1 LASERLAITE  
KLASS 1 LASERAPPARAT

This Compact Disc player is classified as a CLASS 1 LASER product. The CLASS 1 LASER PRODUCT label is located on the rear exterior.



### NOTES ON HANDLING THE OPTICAL PICK-UP BLOCK OR BASE UNIT

The laser diode in the optical pick-up block may suffer electrostatic breakdown because of the potential difference generated by the charged electrostatic load, etc. on clothing and the human body. During repair, pay attention to electrostatic breakdown and also use the procedure in the printed matter which is included in the repair parts. The flexible board is easily damaged and should be handled with care.

### NOTES ON LASER DIODE EMISSION CHECK

The laser beam on this model is concentrated so as to be focused on the disc reflective surface by the objective lens in the optical pick-up block. Therefore, when checking the laser diode emission, observe from more than 30cm away from the objective lens.

### SAFETY-RELATED COMPONENT WARNING!!

COMPONENTS IDENTIFIED BY MARK  OR DOTTED LINE WITH MARK  ON THE SCHEMATIC DIAGRAMS AND IN THE PARTS LIST ARE CRITICAL TO SAFE OPERATION. REPLACE THESE COMPONENTS WITH SONY PARTS WHOSE PART NUMBERS APPEAR AS SHOWN IN THIS MANUAL OR IN SUPPLEMENTS PUBLISHED BY SONY.

## Note on the Transit Key

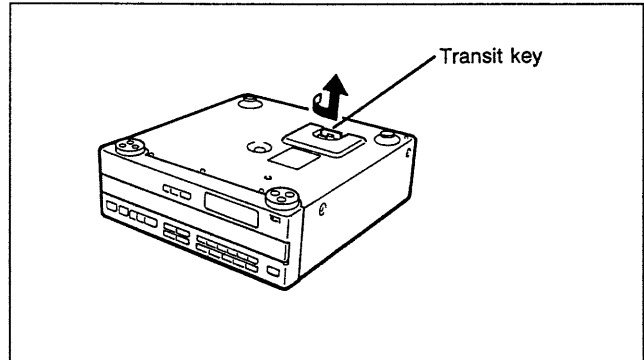

The transit key on the bottom exterior of the unit protects the optical system against shock during transportation. Before operating the CD player, be sure to remove the key by following the instructions on the label, and store it in a safe place.

When transporting the unit, replace the key in its original hole and lock it in place.

### MODEL IDENTIFICATION

#### — Specification Label —

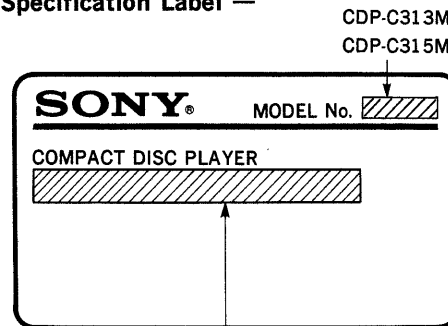

AEP model: AC: 220-230V~50/60Hz

UK, AUS model: AC: 240V~50/60Hz

E model: AC: 110-120, 220-240V~50/60Hz 12W

• AUS: Australian model

## PROTECTION OF EYES FROM LASER BEAM DURING SERVICING

This set employs a laser. Therefore, be sure to follow carefully the instructions below when servicing.

### CAUTION

Use of controls or adjustments or performance of procedures other than those specified herein may result in hazardous radiation exposure.

#### 1. Laser Diode Properties

- Material: GaAlAs
- Wavelength: 780 nm
- Emission Duration: continuous
- Laser Output Power: less than 44.6  $\mu$ W\*

\* This output is the value measured at a distance of 200 mm from the objective lens surface on the Optical Pick-up Block.

2. During service, do not take the Optical Pick-up Block apart, and do not adjust the APC circuit. If there is a breakdown in the APC circuit (including laser diode), replace the entire Optical Pick-up Block (including APC board).

## BESKYTTELSE AF ØJNE MOD LASERSTRÅLING UNDER SERVICE

I dette apparat anvendes laserlys. Derfor skal nedenstående instruktioner nøje følges under service.

Følg iøvrigt instruktionerne i servicemanualen.

### ADVARSEL!!

Under service må øjnene ikke komme nær objektiv-linsen på den optiske pick-up enhed. I tilfælde af at det er nødvendigt at kontrollere udsendelsen af laserlys, skal det ske i en afstand af mere end 25 cm fra den optiske pick-up.

#### 1. Laser-dioe data

- Materiale: GaAlAs
- Bølgelængde: 780 nm
- Udstråling: Kontinuerlig
- Laseroutput: Max. 0,4 mW\*

\* Målt i 1,6 mm afstand fra overfladen af objektiv-linsen på den optiske pick-up enhed.

- Klassifikation: Klasse IIIb.

2. Adskil aldrig den optiske pick-up enhed under service, og juster ikke APC kredsløbet (Automatic Power Control). Hvis APC kredsløbet (incl. laserdioden) bryder ned, skal hele den optiske pick-up enhed (incl. APC printkortet) udskiftes.

## LASER ADVARSEL MÆRKNING

Følgende mærkning findes indvendig i apparatet:

#### 1. Advarsel Mærkning

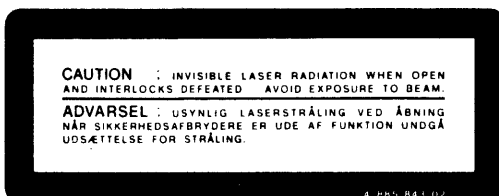

**VAROITUS:** Laite sisältää, laserdiodin, joka lähettää (näkyvätöntä) silmille vaarallista lasersäteilyä.

SECTION 1  
GENERAL

1-1. LOCATION AND CONTROL

Front Panel

CDP-C315M/C313M

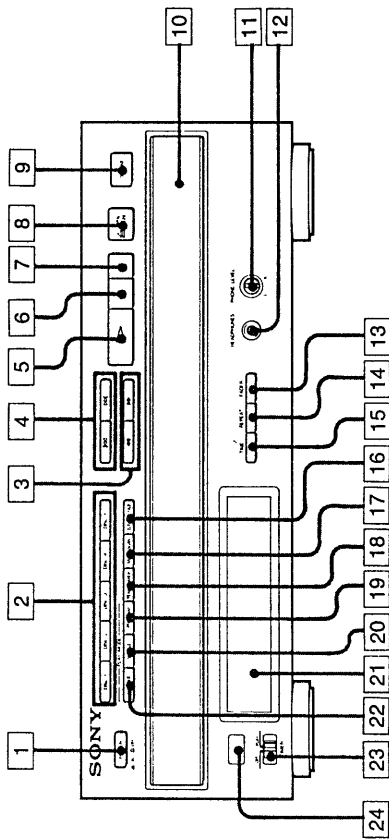

- 1 POWER switch 18
- 2 DISC 1-5 buttons 18 24
- 3 ◀◀/▶▶ (manual search) buttons 24
- 4 ◀◀/▶▶ (AMS\*) buttons 24
- 5 ▶ (play) button 18
- 6 || (pause) button 18
- 7 ■ (stop) button 18
- 8 ▲ OPEN/CLOSE button 18
- 9 DISC SKIP button 18
- 10 Disc tray 18
- 11 PHONE LEVEL control (CDP-C315M/C313M only) 18
- 12 HEADPHONES jack (CDP-C315M/C313M only)
- 13 FADER button 47
- 14 REPEAT button 40
- 15 TIME button 22
- 16 EDIT/TIME FADE button 34
- 17 MUSIC SCAN button 40
- 18 PEAK SEARCH button 45
- 19 PROGRAM button 28
- 20 SHUFFLE button 25
- 21 Display window
- 22 CONTINUE button 18
- 23 TIMER switch 48
- 24 Remote sensor

\* AMS is the abbreviation of Automatic Music Sensor.

This section is extracted from instruction manual.

Remote Commander

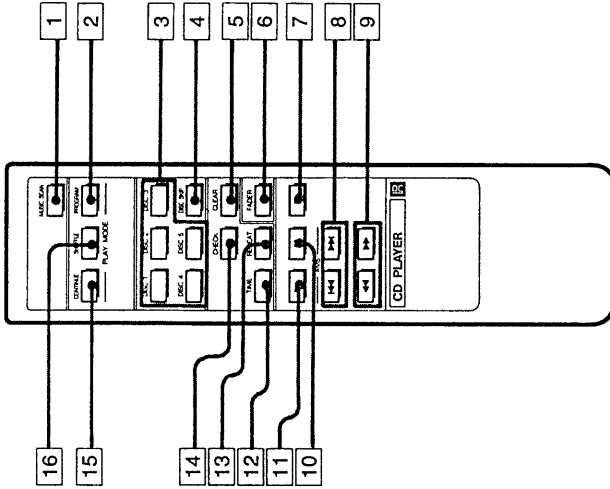

- CDP-C315M/C313M only
- 1 MUSIC SCAN button 40
  - 2 PROGRAM button 28
  - 3 DISC 1-5 buttons 18 24
  - 4 DISC SKIP button 18
  - 5 CLEAR (program clear) button 37
  - 6 FADER button 47
  - 7 ■ (stop) button 18
  - 8 ◀◀▶▶ (AMS) buttons 24
  - 9 ◀◀▶▶ (manual search) buttons 24
  - 10 || (pause) button 18
  - 11 ▶ (play) button 18
  - 12 TIME button 22
  - 13 REPEAT button 40
  - 14 CHECK (program check) button 37
  - 15 CONTINUE button 18
  - 16 SHUFFLE button 25

## SECTION 2 ELECTRICAL BLOCK CHECKING

**Note :**

1. CD Block basically constructed to operate without adjustment. Therefore, check each item in order given.
2. Use YEDS-18 disc (3-702-101-01) unless otherwise indicated.
3. Use the oscilloscope with more than 10MΩ impedance.
4. Clean an object lens by an applicator with neutral detergent when the signal level is low than specified value with the following checks.

**S Curve Check**

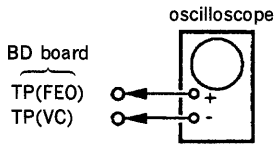

**Procedure :**

1. Connect oscilloscope to test point TP (FEO) on BD board.
2. Connect between test point TP (FES) and TP (VC) by lead wire.
3. Turned Power switch on and actuate the focus serch. (actuate the focus serch when disc table is moving in and out.)
4. Check the oscilloscope waveform (S curve) is symmetrical between A and B. And confirm peak to peak level within  $3 \pm 1V_{p-p}$ .

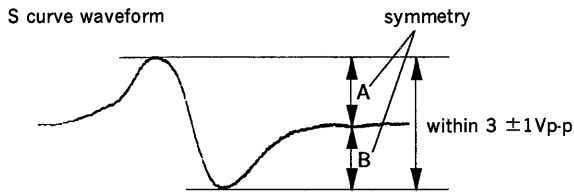

5. After check, remove the lead wire connected in step 2.
- Note :**
- Try to measure several times to make sure that the ratio of A : B or B : A is more than 10 : 7.
  - Take sweep time as long as possible and light up the brightness to obtain best waveform.

**RF Level Check**

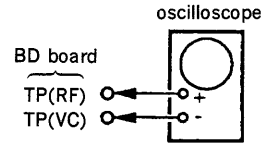

**Procedure :**

1. Connect oscilloscope to test point TP (RF) on BD board.
2. Turn Power switch on.
3. Put disc (YEDS-18) in and playback.
4. Confirm that oscilloscope waveform is clear and check RF signal level is correct or not.

**Note :**

Clear RF signal waveform means that the shape “◇” can be clearly distinguished at the center of the waveform.

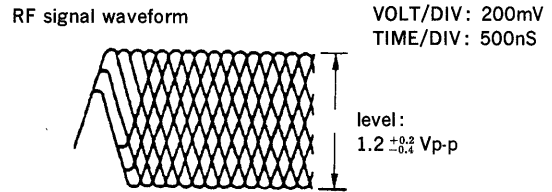

**E-F Balance Check**

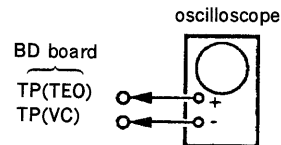

**Procedure :**

1. Connect test point TP (AFJ) to ground and TP (TES) to TP (VC) with lead wire.
2. Connect oscilloscope to test point TP (TEO) on BD board.
3. Turn Power switch on.
4. Put disc (YEDS-18) in and playback.
5. Confirm that the oscilloscope waveform is symmetrical on the top and bottom in relation to 0V, and check this level.

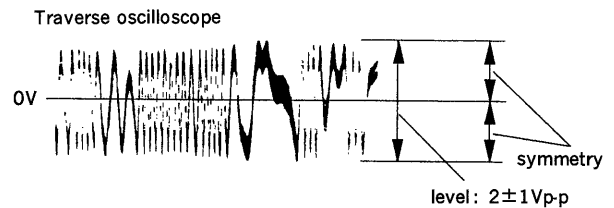

6. Remove the lead wire connected in step 1.

### RF PLL Free-run Frequency Check

#### Procedure :

1. Connect frequency counter to test point (PCK) with lead wire.

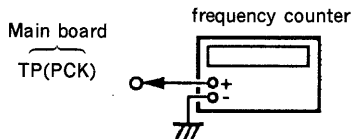

2. Turn Power switch on.
3. Confirm that reading on frequency counter is 4.3218MHz.

### Focus/Tracking Gain

This gain has a margin, so even if it is slightly off.

There is no problem.

Therefore, do not perform, this adjustment.

Please note that it should be fixed to mechanical center position when you moved and do not know original position.

### Adjustment Locations :

[BD board]

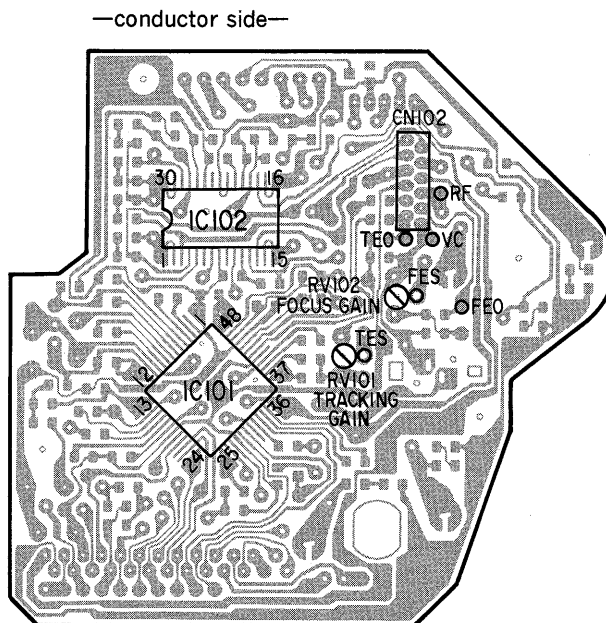

[MAIN board]

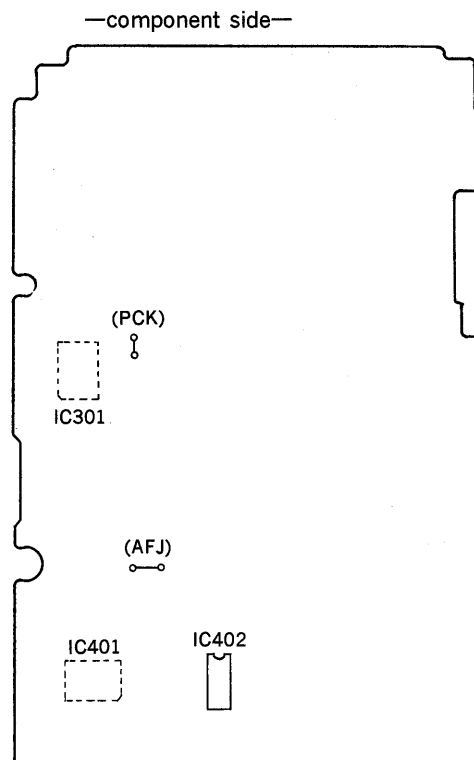

## SECTION 3 DIAGRAMS

### 3-1. CIRCUIT BOARDS LOCATION

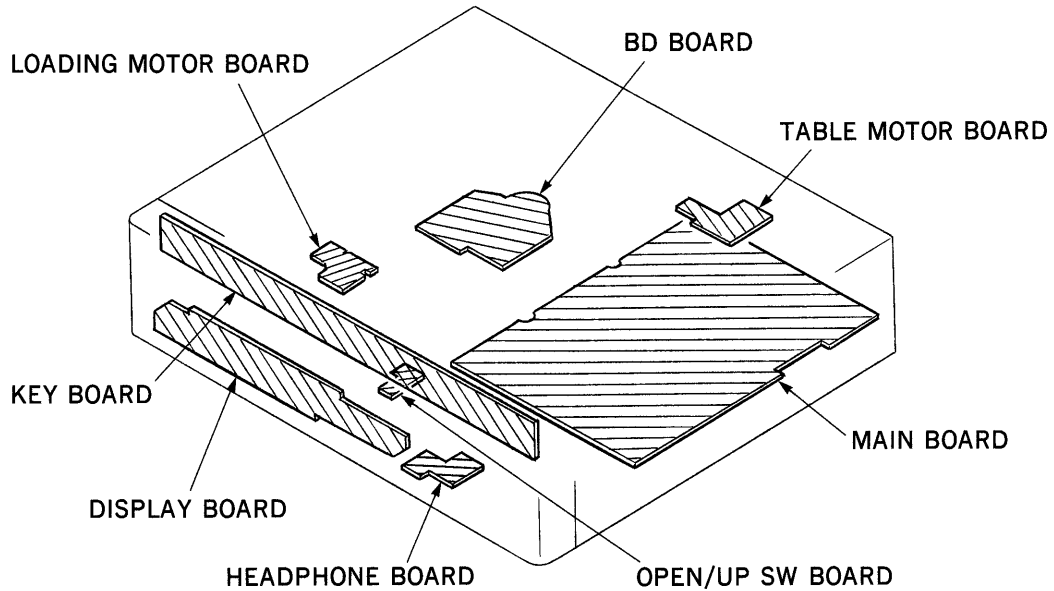

### 3-2. SEMICONDUCTOR LEAD LAYOUTS

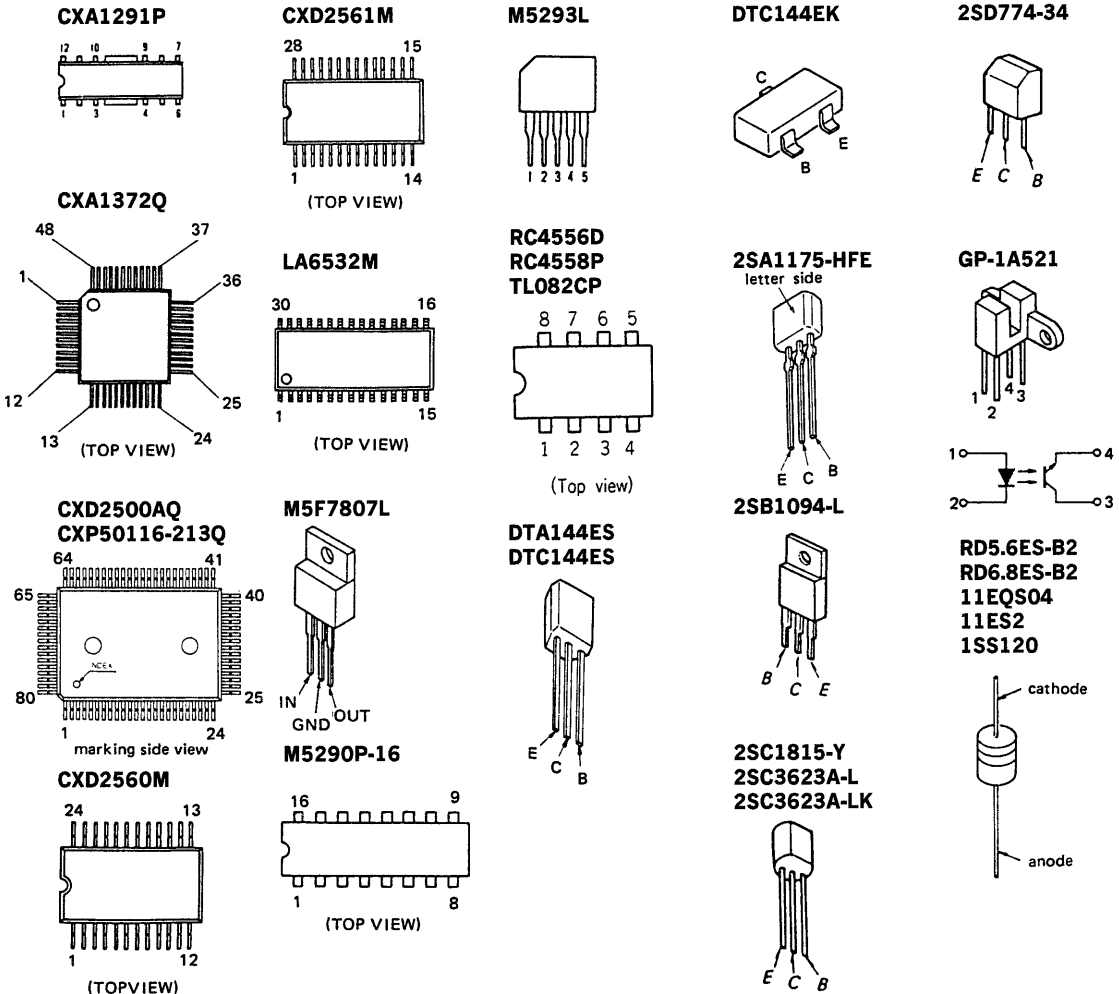

• Semiconductor Location

Ref. No.	Location
D201	C-5
D202	C-5
D203	G-6
D204	G-5
D205	F-6
D206	G-6
D208	G-10
D209	G-11
D341	D-8
D351	D-8
D701	A-18
IC101	C-20
IC102	B-20
IC201	B-5
IC202	E-6
IC203	F-9
IC204	D-5
IC301	B-8
IC302	C-7
IC303	E-8
IC306	E-11
IC307	E-12
IC401	B-13
IC402	D-13
IC453	G-12
IC551	I-15
Q101	D-21
Q201	B-5
Q202	F-6
Q203	G-7
Q204	E-7
Q205	F-7
Q206	F-7
Q209	F-9
Q341	F-13
Q342	F-13
Q343	E-13
Q344	D-9
Q371	E-12
Q372	F-12
Q373	E-12
Q374	F-12
Q375	E-12
Q376	F-12
Q401	C-13

3-3. PRINTED WIRING BOARDS • Refer to Page 7 for Semiconductor Lead Layouts

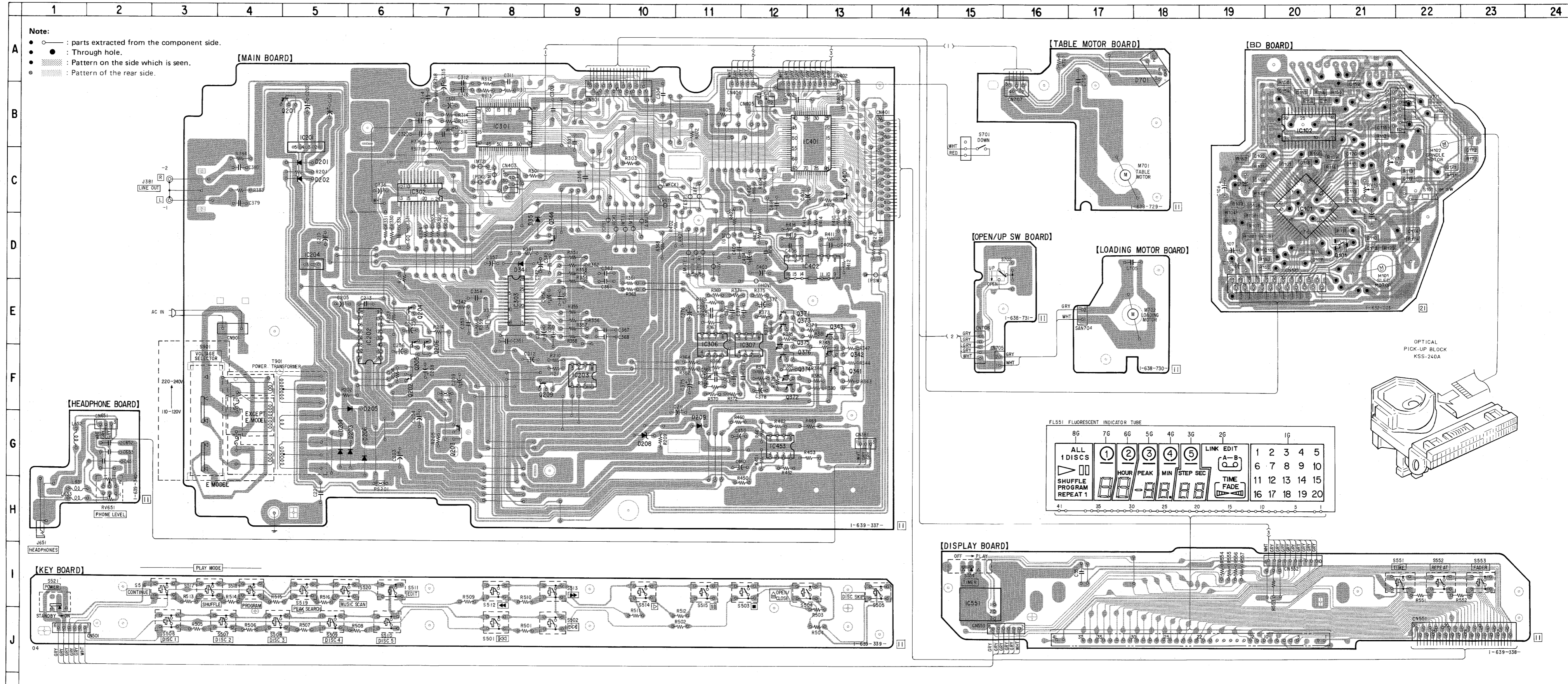



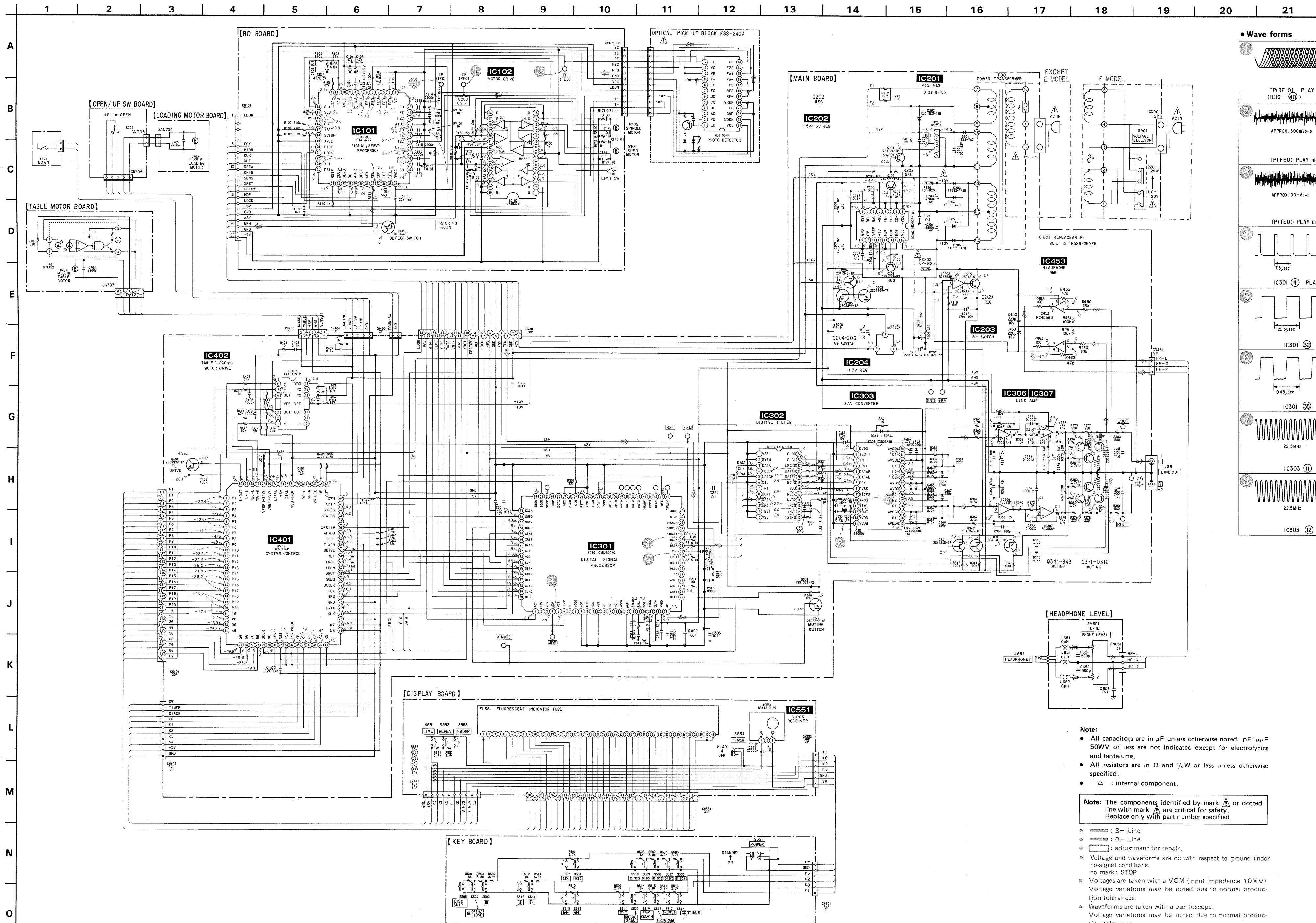

Wave forms

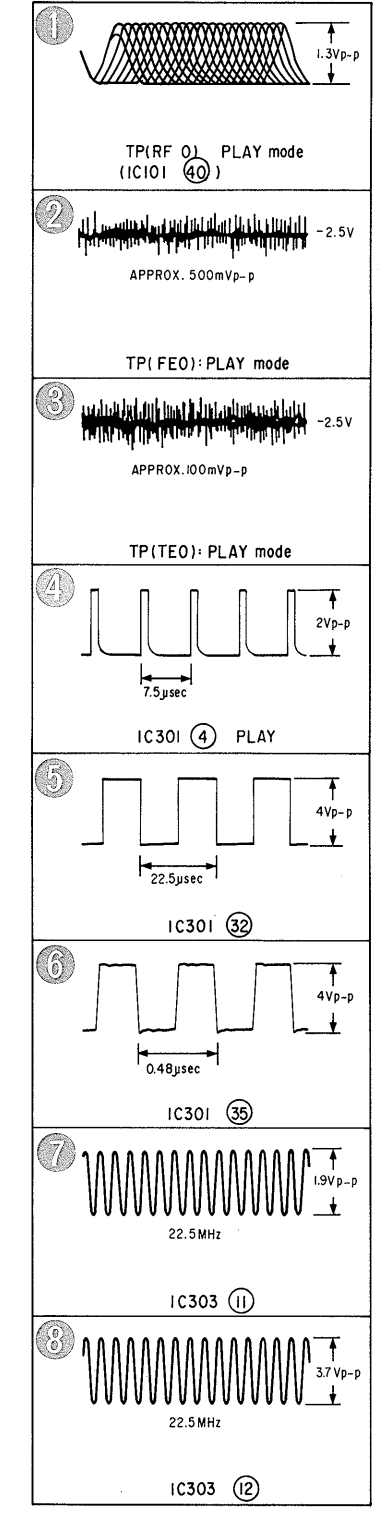

IC Block Diagrams

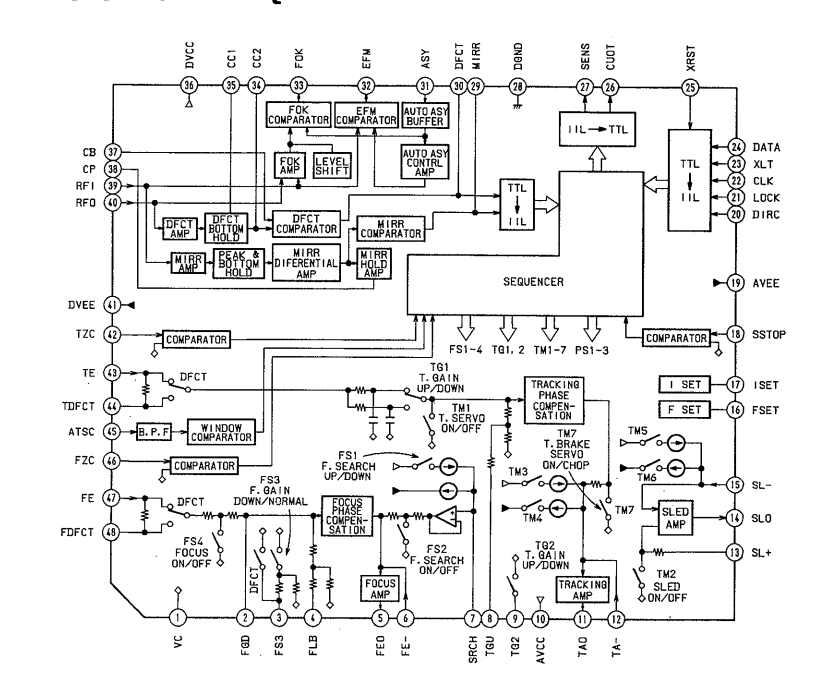

IC301 CXD2500AQ

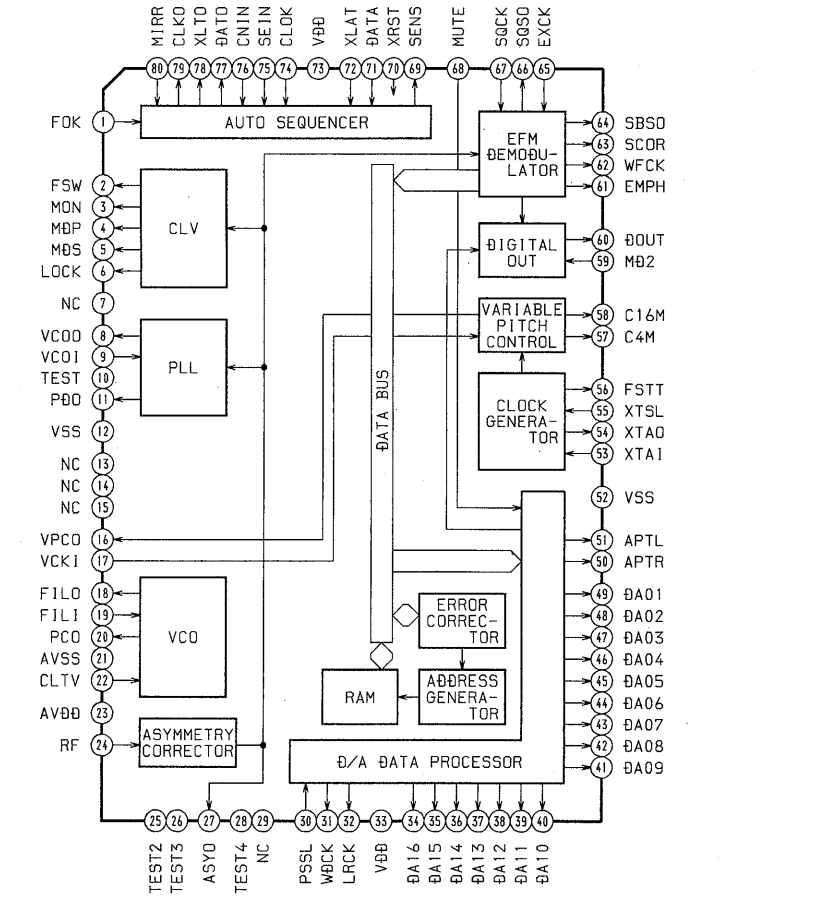

IC202 M5290P

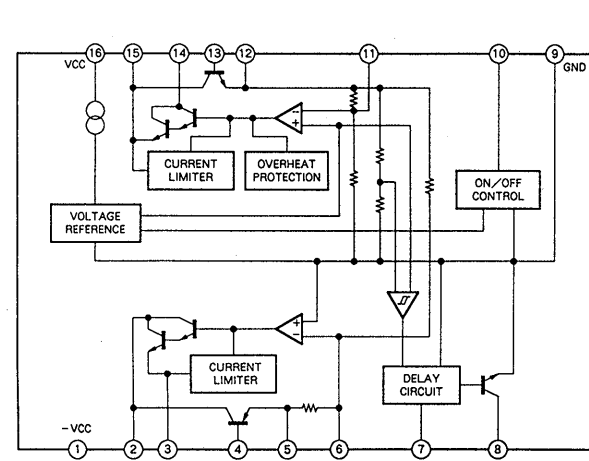

IC402 CXA1291P

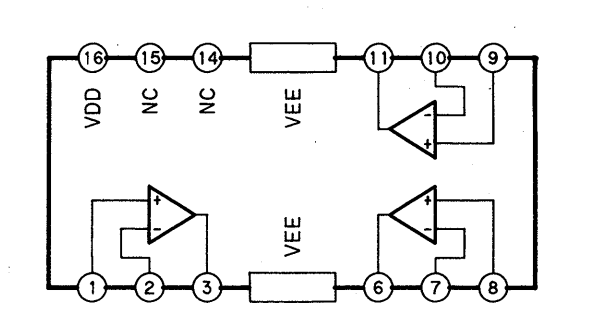

IC201 M5293L

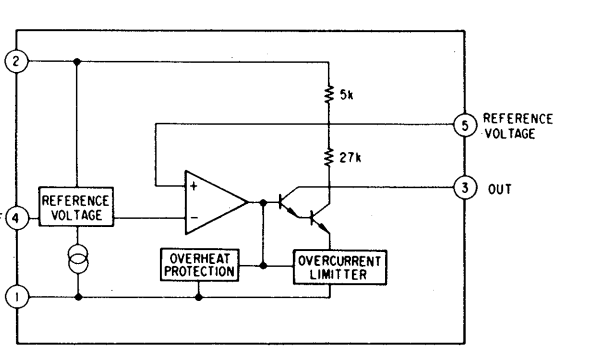

**Note:**  
 • All capacitors are in  $\mu\text{F}$  unless otherwise noted.  $\text{pF}$ :  $\mu\text{F}$  50WV or less are not indicated except for electrolytics and tantalums.  
 • All resistors are in  $\Omega$  and  $1/4\text{W}$  or less unless otherwise specified.  
 •  $\Delta$ : internal component.

**Note:** The components identified by mark  $\Delta$  or dotted line with mark  $\Delta$  are critical for safety. Replace only with part number specified.

- : B+ Line
- : B- Line
- △ : adjustment for repair.
- : Voltage and waveforms are dc with respect to ground under no-signal conditions. no mark: STOP.
- : Voltages are taken with a VOM (Input Impedance  $10\text{M}\Omega$ ). Voltage variations may be noted due to normal production tolerances.
- : Waveforms are taken with an oscilloscope. Voltage variations may be noted due to normal production tolerances.
- : Circled numbers refer to waveforms.
- : Signal path.

# SECTION 4 EXPLODED VIEWS

**NOTE:**

- The mechanical parts with no reference number in the exploded views are not supplied.
- Items marked "※" are not stocked since they are seldom required for routine service. Some delay should be anticipated when ordering these items.

- -XX, -X mean standardized parts, so they may have some differences from the original one.

- Hardware(# mark) list is given in the last of this parts list.

The components identified by mark or dotted line with mark are critical for safety. Replace only with part number specified.

• AUS: Australian Model

**4-1. CABINET ASSEMBLY**

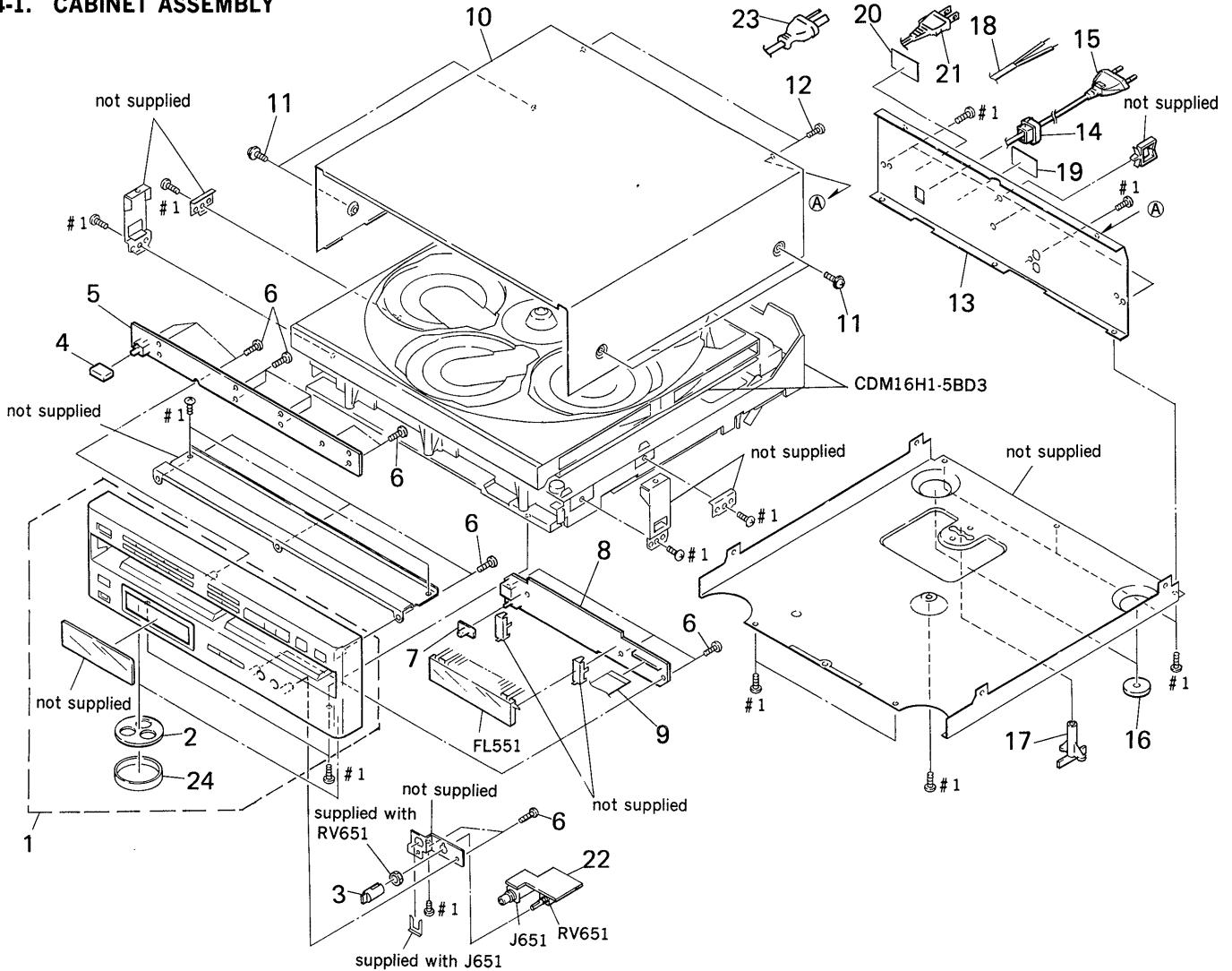

Ref.No.	Part No.	Description	Remark
1	X-4941-567-1	PANEL ASSY. FRONT (C315M)	
1	X-4941-571-1	PANEL ASSY. FRONT (C313M)	
2	4-921-906-01	FELT	
3	4-922-531-11	KNOB (A TYPE). LOV	
4	4-927-341-01	BUTTON (POWER)	
5	* 1-639-339-11	KEY BOARD	
6	4-928-635-01	SCREW, +BV (2.6X8) TAPPING	
7	4-922-518-01	KNOB (TIMER)	
8	* 1-639-338-11	DISPLAY BOARD	
9	1-590-905-11	WIRE, FLAT TYPE (30 CORE)	
10	* 4-943-992-01	CASE	
11	3-704-366-01	SCREW (CASE) (M3X8)	
12	3-703-685-21	SCREW (+BV 3X8)	
13	* 4-943-120-11	PANEL, BACK (AEP)	
13	* 4-943-120-21	PANEL, BACK (AUS)	
13	* 4-943-120-31	PANEL, BACK (E)	

Ref.No.	Part No.	Description	Remark
13	* 4-943-844-01	PANEL, BACK (C313M)	
14	* 3-703-244-00	BUSHING (2104), CORD (EXCEPT FOR E)	
14	* 3-703-571-11	BUSHING (S) (4516), CORD (E)	
15	1-575-651-21	CORD, POWER (AEP)	
16	4-924-410-01	FELT	
17	4-937-945-01	PLATE (TRANSPORT), LOCK	
18	1-558-946-21	CORD, POWER (C313M)	
19	* 4-941-548-01	LABEL, CLASS 1 (AEP, E)	
20	* 4-941-548-01	LABEL, CLASS 1 (AUS, C313M)	
21	1-575-653-21	CORD, POWER (E)	
22	* 1-639-340-11	HEADPHONE BOARD	
23	1-574-358-31	CORD, POWER (WITH CONNECTOR) (AUS)	
24	4-921-918-11	PLATE, ORNAMENTAL	
FL551	1-519-655-11	FLUORESCENT INDICATOR	
J651	1-568-519-21	JACK, LARGE TYPE (HEADPHONE)	
RV651	1-241-507-11	RES. VAR, CARBON 1K/1K (PHONE LEVEL)	

## 4-2. TRAY ASSEMBLY

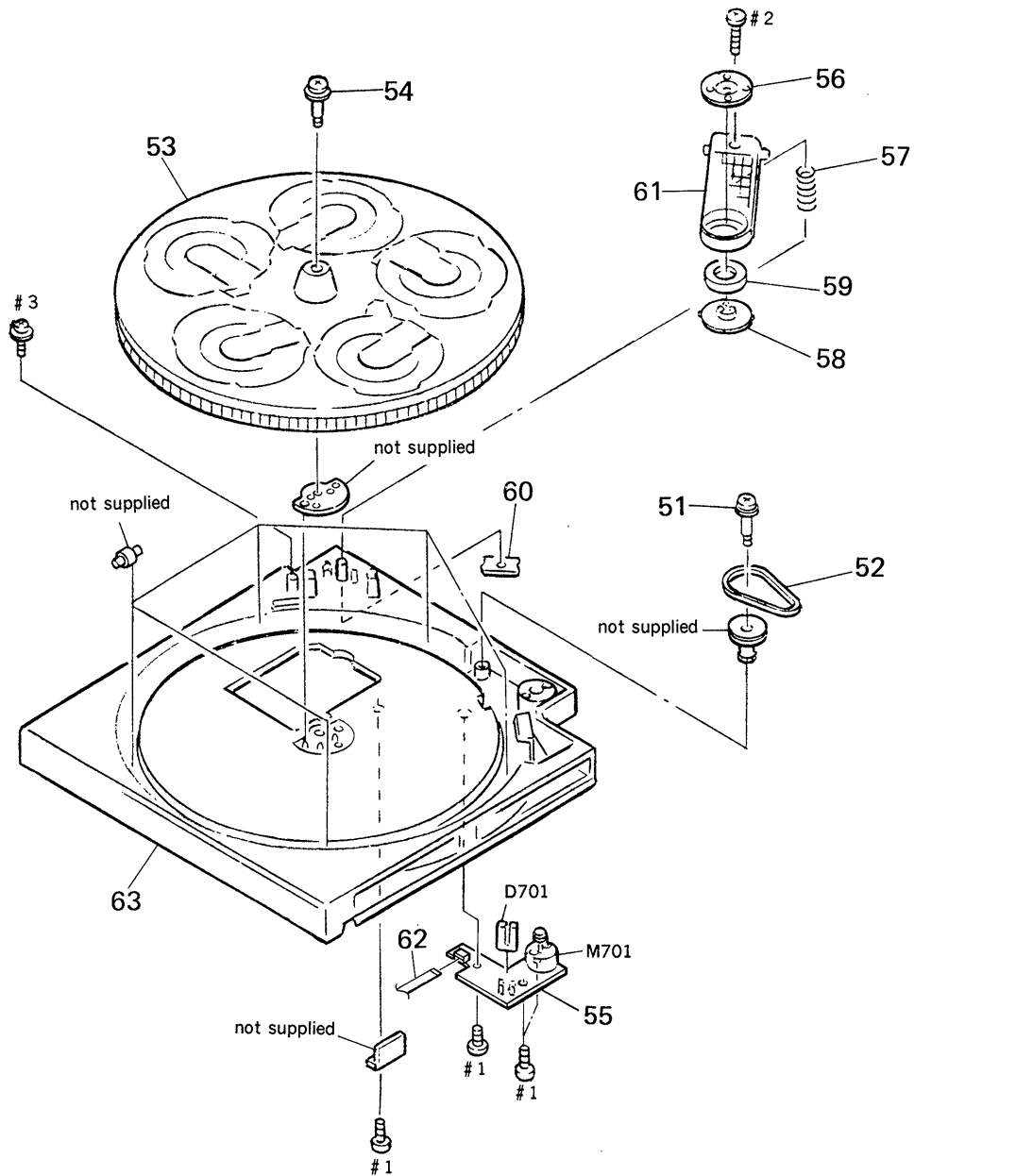

Ref. No.	Part No.	Description	Remark	Ref. No.	Part No.	Description	Remark
51	4-923-597-01	SCREW, STEP		58	4-921-022-01	PULLEY, CHUCKING	
52	4-926-399-01	BELT		59	1-452-340-21	MAGNET	
53	* 4-926-383-02	TABLE (B), DISK		60	* 4-926-388-01	BRACKET (ADJUSTMENT)	
54	4-926-384-01	SCREW, STEP		61	* 4-930-506-02	BRACKET (PRESS PULLEY)	
55	* 1-638-729-11	TABLE MOTOR BOARD		62	1-590-849-11	WIRE, FLAT TYPE (5 CORE)	
56	4-921-029-01	YOKE, CHUCKING		63	4-943-995-01	TABLE (A), DISC	
57	4-926-395-01	SPRING, COMPRESSION		D701	8-719-970-19	DIODE GP1A521	
				M701	A-4604-585-A	MOTOR ASSY, ROTARY	

### 4-3. CHASSIS ASSEMBLY

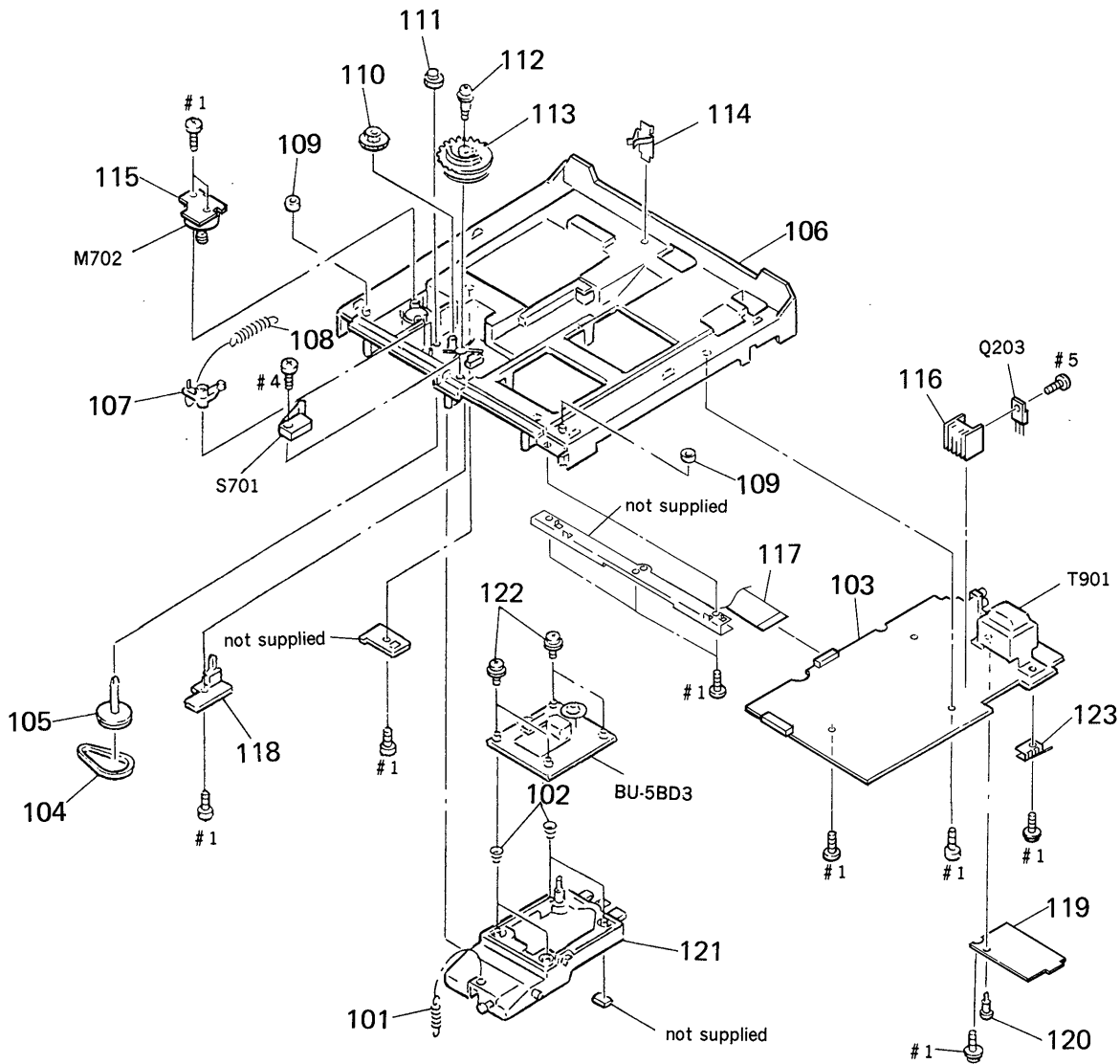

**Note:** The components identified by mark  $\triangle$  or dotted line with mark  $\triangle$  are critical for safety. Replace only with part number specified.

Ref.No.	Part No.	Description	Remark
101	4-937-911-01	SPRING, TENSION	
102	4-917-541-01	SPRING (B)	
103	* A-4617-787-A	MAIN BOARD, COMPLETE (EXCEPT FOR E)	
103	* A-4617-792-A	MAIN BOARD, COMPLETE (E)	
104	4-944-490-01	BELT (TIMING)	
105	X-4941-529-1	PULLEY ASSY	
106	* 4-943-997-01	CHASSIS	
107	4-917-519-01	LEVER, SET	
108	4-924-412-01	SPRING (B), TENSION	
109	* 4-934-382-01	CUSHION	
110	4-934-381-01	GEAR (LOADING C)	
111	4-934-375-01	GEAR (LOADING B)	
112	4-926-317-01	SCREW, STEP	
113	4-934-391-01	GEAR (LOADING A)	

Ref.No.	Part No.	Description	Remark
114	* 4-943-996-01	SPRING, LEAF	
115	* 1-638-370-11	LOADING MOTOR BOARD	
116	* 4-363-146-21	HEAT SINK, V.OUT	
117	1-535-892-11	JUMPER, FILM (WITH TERMINAL)	
118	* 1-638-731-11	OPEN/UP SW BOARD	
119	* 4-944-178-01	SHEET (INSULATING)	
120	3-531-576-11	RIVET	
121	* 4-934-373-01	BRACKET (BU)	
122	4-933-134-01	SCREW (+PTPHW M2. 6X6)	
123	* 4-944-581-01	PLATE, GROUND	
M702	A-4604-834-A	MOTOR ASSY, LOADING	
Q203	8-729-111-67	TRANSISTOR 2SB1094-L	
S701	1-572-713-11	SWITCH, PUSH (WITH CONNECTOR) (DOWN)	
T901	$\triangle$ 1-449-955-11	TRANSFORMER, POWER (EXCEPT FOR E)	
T901	$\triangle$ 1-449-956-11	TRANSFORMER (E)	

#### 4-4. OPTICAL PICK-UP BLOCK (BU-5BD3)

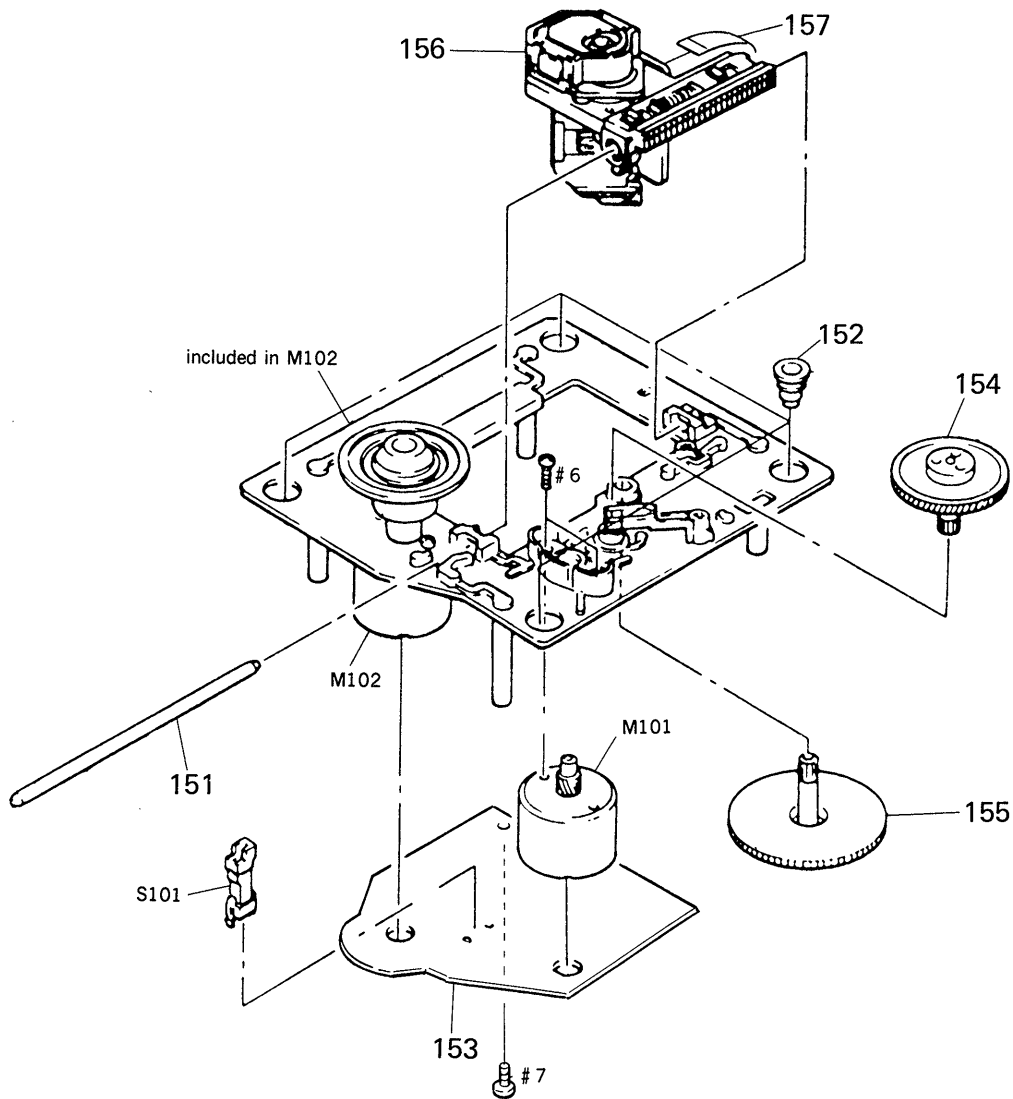

**Note:** The components identified by mark  $\triangle$  or dotted line with mark  $\triangle$  are critical for safety. Replace only with part number specified.

Ref. No.	Part No.	Description	Remark	Ref. No.	Part No.	Description	Remark
151	4-917-565-01	SHAFT, SLED		156	$\triangle$ 8-848-144-11	DEVICE, OPTICAL KSS-240A	
152	4-933-126-01	INSULATOR (A)		157	1-575-001-11	WIRE, FLAT TYPE (12 CORE)	
153	* A-4617-371-A	BD BOARD, COMPLETE		M101	X-4917-504-1	MOTOR ASSY, SLED	
154	4-917-567-01	GEAR (M)		M102	X-4917-523-3	MOTOR ASSY, SPINDLE	
155	4-917-564-01	GEAR (P), FLATNESS		S101	1-572-085-11	SWITCH, LEAF (LIMIT)	

## SECTION 5 ELECTRICAL PARTS LIST

BD

**NOTE:**

- Due to standardization, replacements in the parts list may be different from the parts specified in the diagrams or the components used on the set.
- Items marked "\*" are not stocked since they are seldom required for routine service. Some delay should be anticipated when ordering these items.
- -XX, -X mean standardized parts, so they may have some differences from the original one.
- CAPACITORS  
uF:  $\mu$ F

- RESISTORS  
All resistors are in ohms  
METAL: Metal-film resistor  
METAL OXIDE: Metal Oxide-film resistor  
F: nonflammable
- COILS  
uH:  $\mu$ H
- SEMICONDUCTORS  
In each case, u:  $\mu$ , for example:  
uA...:  $\mu$ A..., uPA...:  $\mu$ PA...,  
uPB...:  $\mu$ PB..., uPC...:  $\mu$ PC...,  
uPD...:  $\mu$ PD....

The components identified by mark  $\Delta$  or dotted line with mark  $\Delta$  are critical for safety.  
Replace only with part number specified.

When indicating parts by reference number, please include the board name.

- AUS: Australian Model

Ref. No.	Part No.	Description	Remark	Ref. No.	Part No.	Description	Remark
	* A-4617-371-A	BD BOARD, COMPLETE *****				< CONNECTOR >	
		< CAPACITOR >				< IC >	
C101	1-163-038-00	CERAMIC CHIP	0.1uF 25V	CN101	1-568-796-11	SOCKET, CONNECTOR 22P	
C102	1-163-989-11	CERAMIC CHIP	0.033uF 10% 25V	CN102	1-568-795-11	SOCKET, CONNECTOR 12P	
C103	1-126-163-11	ELECT	4.7uF 20% 50V			< IC >	
C104	1-163-038-00	CERAMIC CHIP	0.1uF 25V	IC101	8-752-050-82	IC CXA1372Q	
C105	1-126-154-11	ELECT	47uF 20% 6.3V	IC102	8-759-821-94	IC LA6532M	
C106	1-126-154-11	ELECT	47uF 20% 6.3V			< JUMPER >	
C107	1-126-154-11	ELECT	47uF 20% 6.3V	J101	1-216-295-00	METAL CHIP 0 5% 1/10W	
C108	1-163-038-00	CERAMIC CHIP	0.1uF 25V	J102	1-216-295-00	METAL CHIP 0 5% 1/10W	
C109	1-163-038-00	CERAMIC CHIP	0.1uF 25V			< TRANSISTOR >	
C110	1-163-989-11	CERAMIC CHIP	0.033uF 10% 25V	Q101	8-729-901-01	TRANSISTOR DTC144EK	
C111	1-131-367-00	TANTALUM	22uF 10% 20V			< RESISTOR >	
C112	1-164-232-11	CERAMIC CHIP	0.01uF 50V	R101	1-216-097-00	METAL CHIP 100K 5% 1/10W	
C113	1-164-232-11	CERAMIC CHIP	0.01uF 50V	R102	1-216-095-00	METAL CHIP 82K 5% 1/10W	
C114	1-164-161-11	CERAMIC CHIP	0.0022uF 10% 100V	R103	1-216-091-00	METAL CHIP 56K 5% 1/10W	
C115	1-164-161-11	CERAMIC CHIP	0.0022uF 10% 100V	R104	1-216-099-00	METAL CHIP 120K 5% 1/10W	
C117	1-163-038-00	CERAMIC CHIP	0.1uF 25V	R105	1-216-069-00	METAL CHIP 6.8K 5% 1/10W	
C118	1-163-038-00	CERAMIC CHIP	0.1uF 25V	R106	1-216-061-00	METAL CHIP 3.3K 5% 1/10W	
C119	1-164-161-11	CERAMIC CHIP	0.0022uF 10% 100V	R107	1-216-114-00	METAL GLAZE 510K 5% 1/10W	
C120	1-163-989-11	CERAMIC CHIP	0.033uF 10% 25V	R108	1-216-105-00	METAL CHIP 220K 5% 1/10W	
C151	1-163-019-00	CERAMIC CHIP	0.0068uF 10% 50V	R109	1-216-061-00	METAL CHIP 3.3K 5% 1/10W	
C152	1-163-038-00	CERAMIC CHIP	0.1uF 25V	R110	1-216-049-00	METAL CHIP 1K 5% 1/10W	
C153	1-163-006-11	CERAMIC CHIP	560PF 10% 50V	R111	1-216-049-00	METAL CHIP 1K 5% 1/10W	
C154	1-164-161-11	CERAMIC CHIP	0.0022uF 10% 100V	R112	1-216-083-00	METAL CHIP 27K 5% 1/10W	
C155	1-163-023-00	CERAMIC CHIP	0.015uF 5% 50V				
C171	1-163-038-00	CERAMIC CHIP	0.1uF 25V				
C172	1-163-038-00	CERAMIC CHIP	0.1uF 25V				
C173	1-163-038-00	CERAMIC CHIP	0.1uF 25V				
C174	1-163-038-00	CERAMIC CHIP	0.1uF 25V				

BD

MAIN, DISPLAY, KEY, HEADPHONE

Ref. No.	Part No.	Description	Remark
R113	1-216-071-00	METAL CHIP 8.2K	5% 1/10W
R114	1-216-105-00	METAL CHIP 220K	5% 1/10W
R152	1-216-073-00	METAL CHIP 10K	5% 1/10W
R153	1-216-085-00	METAL CHIP 33K	5% 1/10W
R154	1-216-085-00	METAL CHIP 33K	5% 1/10W
R155	1-216-093-00	METAL CHIP 68K	5% 1/10W
R156	1-216-081-00	METAL CHIP 22K	5% 1/10W
R157	1-216-079-00	METAL CHIP 18K	5% 1/10W
R158	1-216-079-00	METAL CHIP 18K	5% 1/10W
R159	1-216-079-00	METAL CHIP 18K	5% 1/10W
R160	1-216-049-00	METAL CHIP 1K	5% 1/10W
R171	1-216-001-00	METAL CHIP 10	5% 1/10W
R172	1-216-001-00	METAL CHIP 10	5% 1/10W
R173	1-216-001-00	METAL CHIP 10	5% 1/10W
R174	1-216-001-00	METAL CHIP 10	5% 1/10W
< VARIABLE RESISTOR >			
RV101	1-238-016-11	RES, ADJ, CARBON 10K	
RV102	1-238-016-11	RES, ADJ, CARBON 10K	
< SWITCH >			
S101	1-572-085-11	SWITCH, LEAF (LIMIT)	
*****			
* A-4617-792-A MAIN BOARD, COMPLETE (E)			
*****			
* A-4617-787-A MAIN BOARD, COMPLETE (AEP, UK, AUS)			
*****			
* 1-639-338-11 DISPLAY BOARD			
*****			
* 1-639-339-11 KEY BOARD			
*****			
* 1-639-340-11 HEADPHONE BOARD			
*****			
* 4-363-146-21 HEAT SINK, V. OUT			
7-682-548-09 SCREW +BVTT 3X8 (S)			
< CAPACITOR >			
C201	1-124-572-11	ELECT 100uF	20% 63V
C202	1-126-059-11	ELECT 10uF	20% 50V
C203	1-126-937-11	ELECT 4700uF	20% 16V
C204	1-126-017-11	ELECT 6800uF	20% 16V
C205	1-126-163-11	ELECT 4.7uF	20% 50V

Ref. No.	Part No.	Description	Remark
C206	1-126-059-11	ELECT 10uF	20% 50V
C207	1-126-059-11	ELECT 10uF	20% 50V
C208	1-124-997-11	ELECT 470uF	20% 10V
C209	1-124-997-11	ELECT 470uF	20% 10V
C210	1-126-024-11	ELECT 220uF	20% 16V
C211	1-124-893-11	ELECT 2200uF	20% 10V
C212	1-124-997-11	ELECT 470uF	20% 10V
C213	1-164-159-11	CERAMIC 0.1uF	50V
C221	1-164-159-11	CERAMIC 0.1uF	50V
C301	1-126-022-11	ELECT 47uF	20% 16V
C302	1-164-159-11	CERAMIC 0.1uF	50V
C303	1-164-159-11	CERAMIC 0.1uF	50V
C304	1-164-159-11	CERAMIC 0.1uF	50V
C305	1-164-159-11	CERAMIC 0.1uF	50V
C311	1-136-161-00	FILM 0.047uF	5% 50V
C312	1-161-374-11	CERAMIC 0.0015uF	20% 50V
C313	1-161-494-00	CERAMIC 0.022uF	25V
C314	1-162-306-11	CERAMIC 0.01uF	20% 16V
C315	1-126-300-11	ELECT 0.47uF	20% 50V
C316	1-161-494-00	CERAMIC 0.022uF	25V
C320	1-164-159-11	CERAMIC 0.1uF	50V
C321	1-164-159-11	CERAMIC 0.1uF	50V
C331	1-162-208-31	CERAMIC 24PF	5% 50V
C336	1-126-022-11	ELECT 47uF	20% 16V
C342	1-126-022-11	ELECT 47uF	20% 16V
C343	1-161-494-00	CERAMIC 0.022uF	25V
C349	1-161-494-00	CERAMIC 0.022uF	25V
C350	1-126-022-11	ELECT 47uF	20% 16V
C351	1-161-494-00	CERAMIC 0.022uF	25V
C353	1-162-196-31	CERAMIC 5.6PF	10% 50V
C354	1-162-196-31	CERAMIC 5.6PF	10% 50V
C355	1-161-494-00	CERAMIC 0.022uF	25V
C356	1-126-022-11	ELECT 47uF	20% 16V
C357	1-124-997-11	ELECT 470uF	20% 10V
C361	1-162-286-31	CERAMIC 220PF	10% 50V
C362	1-162-286-31	CERAMIC 220PF	10% 50V
C363	1-162-285-31	CERAMIC 180PF	10% 50V
C364	1-162-285-31	CERAMIC 180PF	10% 50V
C365	1-162-285-31	CERAMIC 180PF	10% 50V
C366	1-162-285-31	CERAMIC 180PF	10% 50V
C367	1-162-286-31	CERAMIC 220PF	10% 50V
C368	1-162-286-31	CERAMIC 220PF	10% 50V
C371	1-130-479-00	MYLAR 0.0047uF	5% 50V
C372	1-130-479-00	MYLAR 0.0047uF	5% 50V
C373	1-130-472-00	MYLAR 0.0012uF	5% 50V

## MAIN, DISPLAY, KEY, HEADPHONE

Ref. No.	Part No.	Description	Remark
C374	1-130-472-00	MYLAR 0.0012uF 5%	50V
C375	1-126-024-11	ELECT 220uF 20%	16V
C376	1-126-024-11	ELECT 220uF 20%	16V
C377	1-126-022-11	ELECT 47uF 20%	16V
C378	1-126-022-11	ELECT 47uF 20%	16V
C379	1-130-474-00	MYLAR 0.0018uF 5%	50V
C380	1-130-474-00	MYLAR 0.0018uF 5%	50V
C401	1-126-022-11	ELECT 47uF 20%	16V
C402	1-161-494-00	CERAMIC 0.022uF	25V
C403	1-126-023-11	ELECT 100uF 20%	16V
C404	1-126-023-11	ELECT 100uF 20%	16V
C405	1-162-294-31	CERAMIC 0.001uF	10% 50V
C406	1-162-294-31	CERAMIC 0.001uF	10% 50V
C408	1-164-159-11	CERAMIC 0.1uF	50V
C409	1-164-159-11	CERAMIC 0.1uF	50V
C414	1-164-159-11	CERAMIC 0.1uF	50V
C450	1-126-024-11	ELECT 220uF 20%	16V
C460	1-126-024-11	ELECT 220uF 20%	16V
C551	1-161-494-00	CERAMIC 0.022uF	25V
C651	1-162-291-31	CERAMIC 560PF	10% 50V
C652	1-162-291-31	CERAMIC 560PF	10% 50V
C653	1-164-159-11	CERAMIC 0.1uF	50V
< CONNECTOR >			
CN301	* 1-573-046-11	SOCKET, CONNECTOR 18P	
CN401	* 1-573-045-11	SOCKET, CONNECTOR 30P	
CN402	* 1-568-948-11	PIN, CONNECTOR 10P	
CN403	* 1-568-824-11	SOCKET, CONNECTOR 5P	
CN404	* 1-568-943-11	PIN, CONNECTOR 5P	
CN551	* 1-568-933-11	SOCKET, CONNECTOR 30P	
CN901	* 1-573-047-11	PIN, CONNECTOR	
< DIODE >			
D201	8-719-200-82	DIODE 11ES2	
D202	8-719-109-97	DIODE RD6. 8ES-B2	
D203	8-719-200-82	DIODE 11ES2	
D204	8-719-200-82	DIODE 11ES2	
D205	8-719-200-82	DIODE 11ES2	
D206	8-719-200-82	DIODE 11ES2	
D208	8-719-109-89	DIODE RD5. 6ES-B2	
D209	8-719-912-20	DIODE 1SS120	
D341	8-719-210-21	DIODE 11EQS04	
D351	8-719-912-20	DIODE 1SS120	
< FILTER >			
FL551	1-519-655-11	FLUORESCENT INDICATOR	

Ref. No.	Part No.	Description	Remark
< IC >			
IC201	8-759-633-42	IC M5293L	
IC202	8-759-630-21	IC M5290P-16	
IC203	8-759-945-58	IC RC4558P	
IC204	8-759-604-86	IC M5F7807L	
IC301	8-752-337-26	IC CXD2500AQ	
IC302	8-752-342-65	IC CXD2560M	
IC303	8-752-343-01	IC CXD2561M	
IC306	8-759-990-82	IC TL082CP	
IC307	8-759-945-58	IC RC4558P	
IC401	8-752-817-42	IC CXP50116-223Q	
IC402	8-759-035-28	IC CXA1291P	
IC453	8-759-981-85	IC RC4556D	
IC551	8-741-100-48	IC SBX1610-59	
< JACK >			
J381	1-569-442-11	JACK, PIN 2P (LINE OUT)	
J651	1-568-519-21	JACK, LARGE TYPE (HEADPHONES)	
< COIL >			
L331	1-408-403-00	INDUCTOR	3.3uH
L651	1-412-473-21	INDUCTOR	0uH
L652	1-412-473-21	INDUCTOR	0uH
L653	1-412-473-21	INDUCTOR	0uH
< IC LINK >			
PS201	△ 1-532-685-00	LINK, IC	
PS202	△ 1-532-637-00	LINK, IC	1.0A
< TRANSISTOR >			
Q201	8-729-119-76	TRANSISTOR	2SA1175-HFE
Q202	8-729-140-96	TRANSISTOR	2SD774-34
Q203	8-729-111-67	TRANSISTOR	2SB1094-L
Q204	8-729-900-65	TRANSISTOR	DTA144ES
Q205	8-729-900-89	TRANSISTOR	DTC144ES
Q206	8-729-900-89	TRANSISTOR	DTC144ES
Q209	8-729-281-52	TRANSISTOR	2SC1815-Y
Q341	8-729-900-65	TRANSISTOR	DTA144ES
Q342	8-729-900-65	TRANSISTOR	DTA144ES
Q343	8-729-900-65	TRANSISTOR	DTA144ES
Q344	8-729-900-89	TRANSISTOR	DTC144ES
Q371	8-729-141-30	TRANSISTOR	2SC3623A-LK
Q372	8-729-141-30	TRANSISTOR	2SC3623A-LK
Q373	8-729-141-30	TRANSISTOR	2SC3623A-LK
Q374	8-729-141-30	TRANSISTOR	2SC3623A-LK
Q375	8-729-107-84	TRANSISTOR	2SC3623A-L
Q376	8-729-107-84	TRANSISTOR	2SC3623A-L
Q401	8-729-900-89	TRANSISTOR	DTC144ES

Note: The components identified by mark △ or dotted line with mark △ are critical for safety. Replace only with part number specified.



## MAIN, DISPLAY, KEY, HEADPHONE

Ref. No.	Part No.	Description	Remark	Ref. No.	Part No.	Description	Remark
		< RESISTOR >					
R201	1-249-435-11	CARBON	33K 5% 1/4W	R359	1-247-903-00	CARBON	1M 5% 1/4W
R202	1-249-438-11	CARBON	56K 5% 1/4W	R361	1-249-423-11	CARBON	3.3K 5% 1/4W
R203	1-249-429-11	CARBON	10K 5% 1/4W	R362	1-249-423-11	CARBON	3.3K 5% 1/4W
R204	1-249-425-11	CARBON	4.7K 5% 1/4W	R363	1-249-423-11	CARBON	3.3K 5% 1/4W
R205	1-249-425-11	CARBON	4.7K 5% 1/4W	R364	1-249-423-11	CARBON	3.3K 5% 1/4W
R208	1-249-423-11	CARBON	3.3K 5% 1/4W	R365	1-249-430-11	CARBON	12K 5% 1/4W
R209	1-249-413-11	CARBON	470 5% 1/4W	R366	1-249-430-11	CARBON	12K 5% 1/4W
R210	1-249-429-11	CARBON	10K 5% 1/4W	R367	1-249-430-11	CARBON	12K 5% 1/4W
R211	1-249-410-11	CARBON	270 5% 1/4W	R368	1-249-430-11	CARBON	12K 5% 1/4W
R212	1-249-392-11	CARBON	8.2 5% 1/4W	R369	1-249-419-11	CARBON	1.5K 5% 1/4W
R213	1-249-392-11	CARBON	8.2 5% 1/4W	R370	1-249-419-11	CARBON	1.5K 5% 1/4W
R214	1-249-417-11	CARBON	1K 5% 1/4W	R371	1-249-419-11	CARBON	1.5K 5% 1/4W
R301	1-249-411-11	CARBON	330 5% 1/4W	R372	1-249-419-11	CARBON	1.5K 5% 1/4W
R302	1-249-417-11	CARBON	1K 5% 1/4W	R373	1-247-887-00	CARBON	220K 5% 1/4W
R303	1-249-417-11	CARBON	1K 5% 1/4W	R374	1-247-887-00	CARBON	220K 5% 1/4W
R311	1-249-423-11	CARBON	3.3K 5% 1/4W	R375	1-249-409-11	CARBON	220 5% 1/4W
R312	1-249-429-11	CARBON	10K 5% 1/4W	R376	1-249-409-11	CARBON	220 5% 1/4W
R313	1-249-423-11	CARBON	3.3K 5% 1/4W	R377	1-249-409-11	CARBON	220 5% 1/4W
R314	1-249-429-11	CARBON	10K 5% 1/4W	R378	1-249-409-11	CARBON	220 5% 1/4W
R315	1-249-417-11	CARBON	1K 5% 1/4W	R379	1-249-425-11	CARBON	4.7K 5% 1/4W
R316	1-249-417-11	CARBON	1K 5% 1/4W	R380	1-249-425-11	CARBON	4.7K 5% 1/4W
R317	1-249-420-11	CARBON	1.8K 5% 1/4W	R381	1-249-425-11	CARBON	4.7K 5% 1/4W
R318	1-249-441-11	CARBON	100K 5% 1/4W	R382	1-249-425-11	CARBON	4.7K 5% 1/4W
R321	1-249-417-11	CARBON	1K 5% 1/4W	R383	1-249-414-11	CARBON	560 5% 1/4W
R322	1-249-417-11	CARBON	1K 5% 1/4W	R384	1-249-414-11	CARBON	560 5% 1/4W
R323	1-249-417-11	CARBON	1K 5% 1/4W	R385	1-249-393-11	CARBON	10 5% 1/4W
R324	1-249-417-11	CARBON	1K 5% 1/4W	R386	1-249-393-11	CARBON	10 5% 1/4W
R330	1-249-417-11	CARBON	1K 5% 1/4W	R401	1-249-433-11	CARBON	22K 5% 1/4W
R331	1-249-417-11	CARBON	1K 5% 1/4W	R402	1-249-433-11	CARBON	22K 5% 1/4W
R341	1-249-393-11	CARBON	10 5% 1/4W	R403	1-249-433-11	CARBON	22K 5% 1/4W
R342	1-249-417-11	CARBON	1K 5% 1/4W	R404	1-249-425-11	CARBON	4.7K 5% 1/4W
R343	1-249-441-11	CARBON	100K 5% 1/4W	R405	1-249-425-11	CARBON	4.7K 5% 1/4W
R344	1-249-441-11	CARBON	100K 5% 1/4W	R406	1-249-425-11	CARBON	4.7K 5% 1/4W
R345	1-249-425-11	CARBON	4.7K 5% 1/4W	R408	1-249-441-11	CARBON	100K 5% 1/4W
R346	1-249-425-11	CARBON	4.7K 5% 1/4W	R409	1-247-864-11	CARBON	24K 5% 1/4W
R347	1-249-441-11	CARBON	100K 5% 1/4W	R410	1-247-880-11	CARBON	110K 5% 1/4W
R348	1-249-429-11	CARBON	10K 5% 1/4W	R411	1-249-440-11	CARBON	82K 5% 1/4W
R351	1-249-428-11	CARBON	8.2K 5% 1/4W	R412	1-247-876-11	CARBON	75K 5% 1/4W
R352	1-249-428-11	CARBON	8.2K 5% 1/4W	R413	1-249-440-11	CARBON	82K 5% 1/4W
R353	1-249-428-11	CARBON	8.2K 5% 1/4W	R414	1-247-874-11	CARBON	62K 5% 1/4W
R354	1-249-428-11	CARBON	8.2K 5% 1/4W	R415	1-249-435-11	CARBON	33K 5% 1/4W
R355	1-249-428-11	CARBON	8.2K 5% 1/4W	R416	1-247-878-00	CARBON	91K 5% 1/4W
R356	1-249-428-11	CARBON	8.2K 5% 1/4W	R421	1-249-393-11	CARBON	10 5% 1/4W
R357	1-249-428-11	CARBON	8.2K 5% 1/4W	R422	1-249-393-11	CARBON	10 5% 1/4W
R358	1-249-428-11	CARBON	8.2K 5% 1/4W	R450	1-249-435-11	CARBON	33K 5% 1/4W

MAIN, DISPLAY, KEY, HEADPHONE

TABLEMOTOR, LOADING MOTOR, OPEN/UP SW

Ref.No.	Part No.	Description	Remark
R451	1-249-441-11	CARBON	100K 5% 1/4W
R452	1-249-437-11	CARBON	47K 5% 1/4W
R453	1-249-405-11	CARBON	100 5% 1/4W
R460	1-249-435-11	CARBON	33K 5% 1/4W
R461	1-249-441-11	CARBON	100K 5% 1/4W
R462	1-249-437-11	CARBON	47K 5% 1/4W
R463	1-249-405-11	CARBON	100 5% 1/4W
R501	1-249-422-11	CARBON	2. 7K 5% 1/4W
R502	1-249-424-11	CARBON	3. 9K 5% 1/4W
R503	1-249-427-11	CARBON	6. 8K 5% 1/4W
R504	1-249-432-11	CARBON	18K 5% 1/4W
R505	1-249-422-11	CARBON	2. 7K 5% 1/4W
R506	1-249-424-11	CARBON	3. 9K 5% 1/4W
R507	1-249-427-11	CARBON	6. 8K 5% 1/4W
R508	1-249-432-11	CARBON	18K 5% 1/4W
R509	1-249-422-11	CARBON	2. 7K 5% 1/4W
R510	1-249-424-11	CARBON	3. 9K 5% 1/4W
R511	1-249-427-11	CARBON	6. 8K 5% 1/4W
R512	1-249-432-11	CARBON	18K 5% 1/4W
R513	1-249-422-11	CARBON	2. 7K 5% 1/4W
R514	1-249-424-11	CARBON	3. 9K 5% 1/4W
R515	1-249-427-11	CARBON	6. 8K 5% 1/4W
R516	1-249-432-11	CARBON	18K 5% 1/4W
R551	1-249-422-11	CARBON	2. 7K 5% 1/4W
R552	1-249-424-11	CARBON	3. 9K 5% 1/4W
R553	1-249-429-11	CARBON	10K 5% 1/4W
R554	1-249-429-11	CARBON	10K 5% 1/4W
R555	1-249-429-11	CARBON	10K 5% 1/4W
R556	1-249-429-11	CARBON	10K 5% 1/4W
R557	1-249-429-11	CARBON	10K 5% 1/4W
< VARIABLE RESISTOR >			
RV651	1-241-507-11	RES, VAR, CARBON 1K/1K (PHONE LEVEL)	
< SWITCH >			
S501	1-554-303-21	SWITCH, TACTILE (K<K)	
S502	1-554-303-21	SWITCH, TACTILE (>D<)	
S503	1-554-303-21	SWITCH, TACTILE (■)	
S504	1-554-303-21	SWITCH, TACTILE (OPEN/CLOSE)	
S505	1-554-303-21	SWITCH, TACTILE (DISC SKIP)	
S506	1-554-303-21	SWITCH, TACTILE (DISC 1)	
S507	1-554-303-21	SWITCH, TACTILE (DISC 2)	
S508	1-554-303-21	SWITCH, TACTILE (DISC 3)	
S509	1-554-303-21	SWITCH, TACTILE (DISK 4)	
S510	1-554-303-21	SWITCH, TACTILE (DISK 5)	
S511	1-554-303-21	SWITCH, TACTILE (EDIT)	
S512	1-554-303-21	SWITCH, TACTILE (<<)	
S513	1-554-303-21	SWITCH, TACTILE (>>)	
S514	1-554-303-21	SWITCH, TACTILE (>)	

Ref.No.	Part No.	Description	Remark
S515	1-554-303-21	SWITCH, TACTILE (□□)	
S516	1-554-303-21	SWITCH, TACTILE (CONTINUE)	
S517	1-554-303-21	SWITCH, TACTILE (SHUFFLE)	
S518	1-554-303-21	SWITCH, TACTILE (PROGRAM)	
S519	1-554-303-21	SWITCH, TACTILE (PEAK SEARCH)	
S520	1-554-303-21	SWITCH, TACTILE (MUSIC SEAN)	
S521	1-572-714-11	SWITCH, PUSH (POWER)	
S551	1-554-303-21	SWITCH, TACTILE (TIME)	
S552	1-554-303-21	SWITCH, TACTILE (REPEAT)	
S553	1-554-303-21	SWITCH, TACTILE (FADER)	
S554	1-570-157-51	SWITCH, SLIDE (TIMER)	
S901	△. 1-571-722-11	SWITCH, VOLTAGE SELECTION (VOLTAGE SELECTOR)	
< CRYSTAL >			
X351	1-567-965-11	VIBRATOR, CRYSTAL (22.5MHz)	
*****			
* 1-638-729-11 TABLE MOTOR BOARD *****			
* 1-638-730-11 LOADING MOTOR BOARD *****			
* 1-638-731-11 OPEN/UP SW BOARD *****			
< CAPACITOR >			
C704	1-161-375-00	CERAMIC	0.0022uF 20% 50V
C705	1-161-375-00	CERAMIC	0.0022uF 20% 50V
< CONNECTOR >			
CN705	* 1-566-214-11	PIN, CONNECTOR (PC BOARD)	2P
CN707	* 1-573-044-11	SOCKET, CONNECTOR	
< DIODE >			
D701	8-719-970-19	DIODE	GP1A521
< RESISTOR >			
R701	1-249-416-11	CARBON	820 5% 1/4W
< SWITCH >			
S702	1-571-300-21	SWITCH, ROTARY (OPEN/UP)	
*****			

Note: The components identified by mark △ or dotted line with mark △ are critical for safety. Replace only with part number specified.

Ref. No.	Part No.	Description	Remark
MISCELLANEOUS *****			
9	1-590-905-11	WIRE, FLAT TYPE (30 CORE)	
15	1-575-651-21	CORD, POWER (AEP)	
18	△. 1-558-946-21	CORD, POWER (C313M)	
21	△. 1-575-653-21	CORD, POWER (E)	
23	△. 1-574-358-31	CORD, POWER (WITH CONNECTOR) (AUS)	
59	1-452-340-21	MAGNET	
62	1-590-849-11	WIRE, FLAT TYPE (5 CORE)	
117	1-535-892-11	JUMPER, FILM (WITH TERMINAL)	
156	△. 8-848-144-11	DEVICE, OPTICAL KSS-240A	
157	1-575-001-11	WIRE, FLAT TYPE (12 CORE)	
M101	X-4917-504-1	MOTOR ASSY, SLED	
M102	X-4917-523-3	MOTOR ASSY, SPINDLE	
M701	A-4604-585-A	MOTOR ASSY, ROTARY	
M702	A-4604-834-A	MOTOR ASSY, LOADING	
S701	1-572-713-11	SWITCH, PUSH (WITH CONNECTOR) (DOWN)	
T901	1-449-955-11	TRANSFORMER, POWER (EXCEPT FOR E)	
T901	1-449-956-11	TRANSFORMER (E)	

\*\*\*\*\*

ACCESSORY & PACKING MATERIAL  
\*\*\*\*\*

- 1-465-733-11 REMOTE COMMANDER (RM-D315)
- 1-559-533-11 CORD, CONNECTION
- △. 1-569-007-11 ADAPTER, CONVERSION 2P (E)
- 2-181-754-01 COVER, BATTERY
- 3-753-030-11 MANUAL, INSTRUCTION (EXCEPT FOR AUS)  
(ENGLISH, FRENCH, SPANISH, PORTUGUES)
- 3-753-030-21 MANUAL, INSTRUCTION (AUS) (ENGLISH)
- 3-753-030-41 MANUAL, INSTRUCTION (AEP) (GERMAN, DUTCH,  
SWEDISH, ITALIAN)
- \* 4-944-039-21 INDIVIDUAL CARTON (C313M)
- \* 4-944-039-41 INDIVIDUAL CARTON (C315M)
- \* 4-944-040-01 CUSHION (FRONT)
- \* 4-944-041-01 CUSHION (REAR)

\*\*\*\*\*

HARDWARE LIST  
\*\*\*\*\*

- # 1 7-685-647-79 SCREW +BVTP 3X10 TYPE2 N-S
- # 2 7-682-554-04 SCREW +B 3X25
- # 3 7-685-648-79 SCREW (M3X12), TAPPING
- # 4 7-685-136-19 SCREW +P 2.6X12 TYPE2 NON-SLIT
- # 5 7-682-548-09 SCREW +BVTT 3X8 (S)
- # 6 7-621-255-15 SCREW +P 2X3
- # 7 7-685-134-19 SCREW +BTP 2.6X8 TYPE2 N-S

**Note:** The components identified by mark △ or dotted line with mark △ are critical for safety. Replace only with part number specified.