

CDP-C325M/C422M

SERVICE MANUAL

*AEP Model
UK Model
E Model
Australian Model*



Photo : CDP-C325M

Model Name Using Similar Mechanism	CDP-C225/C325
Optical Pick-up Block Type	BU-5BD8B

SPECIFICATIONS

	CDP-C325M	CDP-C422M
System	Compact disc digital audio system	
Laser	Semiconductor laser ($\lambda = 780 \text{ nm}$) Emission duration: continuous	
Laser output	Max. $44.6 \mu\text{W}^*$ * This output is the value measured at a distance of about 200 mm from the objective lens surface on the Optical Pick-up Block.	
Frequency response	2 Hz – 20 kHz ($\pm 0.5 \text{ dB}$)	
Signal to noise ratio	More than 100 dB	
Dynamic range	More than 98 dB	
Harmonic distortion	Less than 0.005% (1 kHz)	
Channel separation	More than 100 dB (1 kHz)	
Wow and flutter	Below measurable limit	
Outputs LINE OUT (phono jacks)	Output level 2 V (at 50 kilohms) Load impedance over 10 kilohms	
HEADPHONES (stereo phone jack)	Output level 0 – 10 mW (variable) (at 32 ohms)	

General

Power requirements	UK, Australian model: 240 V AC, 50/60 Hz AEP, East European model: 220–230 V AC, 50/60 Hz E model: 110 – 120 or 220 – 240 V AC adjustable, 50/60 Hz
Power consumption	12 W
Dimensions (not including projecting parts and controls)	Approx. $355 \times 120 \times 385 \text{ mm}$ (w/h/d) ($14 \times 4\frac{3}{4} \times 15\frac{1}{4}$ inches)
Weight	Approx. 5.0 kg (11 lbs 01 oz)

Supplied accessories

	CDP-C325M	CDP-C422M
Audio signal connecting cord	1 (phono plug $\times 2 \leftrightarrow$ phono plug $\times 2$)	
Remote commander	1 (RM-D325)	
Sony SUM-3 (NS) batteries	2	

Design and specifications subject to change without notice.

COMPACT DISC PLAYER
SONY[®]

For the United Kingdom and European Countries.

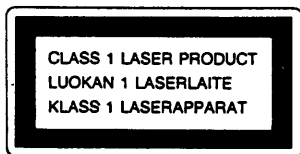

This Compact Disc player is classified as a CLASS 1 LASER product. The CLASS 1 LASER PRODUCT label is located on the rear exterior.

NOTES ON HANDLING THE OPTICAL PICK-UP BLOCK OR BASE UNIT

The laser diode in the optical pick-up block may suffer electrostatic breakdown because of the potential difference generated by the charged electrostatic load, etc. on clothing and the human body. During repair, pay attention to electrostatic breakdown and also use the procedure in the printed matter which is included in the repair parts. The flexible board is easily damaged and should be handled with care.

NOTES ON LASER DIODE EMISSION CHECK

The laser beam on this model is concentrated so as to be focused on the disc reflective surface by the objective lens in the optical pick-up block. Therefore, when checking the laser diode emission, observe from more than 30cm away from the objective lens.

SAFETY-RELATED COMPONENT WARNING!!

COMPONENTS IDENTIFIED BY MARK OR DOTTED LINE WITH MARK ON THE SCHEMATIC DIAGRAMS AND IN THE PARTS LIST ARE CRITICAL TO SAFE OPERATION. REPLACE THESE COMPONENTS WITH SONY PARTS WHOSE PART NUMBERS APPEAR AS SHOWN IN THIS MANUAL OR IN SUPPLEMENTS PUBLISHED BY SONY.

Note on the Transit Key

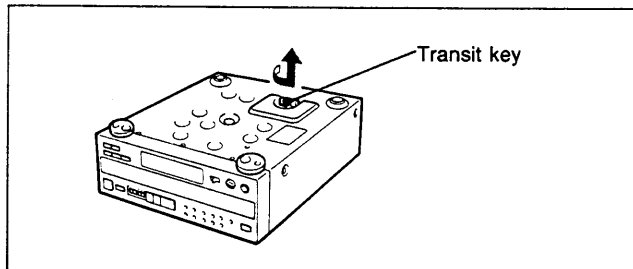

The transit key on the bottom exterior of the unit protects the optical system against shock during transportation. Before operating the CD player, be sure to remove the key by following the instructions on the label, and store it in a safe place.

When transporting the unit, replace the key in its original hole and lock it in place.

MODEL IDENTIFICATION

— Specification Label —

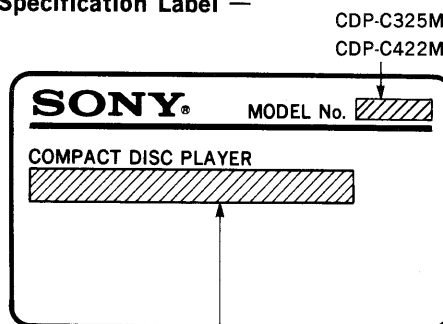

AEP, EE model: AC: 220—230V~50/60Hz
 UK, AUS model: AC: 240V~50/60Hz
 E model: AC: 110—120, 220—240V~50/60Hz 12W

- AUS: Australian model
- EE : East European model

PROTECTION OF EYES FROM LASER BEAM DURING SERVICING

This set employs a laser. Therefore, be sure to follow carefully the instructions below when servicing.

CAUTION

Use of controls or adjustments or performance of procedures other than those specified herein may result in hazardous radiation exposure.

1. Laser Diode Properties

- Material: GaAlAs
- Wavelength: 780 nm
- Emission Duration: continuous
- Laser Output Power: less than 44.6 μ W*

* This output is the value measured at a distance of 200 mm from the objective lens surface on the Optical Pick-up Block.

2. During service, do not take the Optical Pick-up Block apart, and do not adjust the APC circuit. If there is a breakdown in the APC circuit (including laser diode), replace the entire Optical Pick-up Block (including APC board).

BESKYTTELSE AF ØJNE MOD LASERSTRÅLING UNDER SERVICE

I dette apparat anvendes laserlys. Derfor skal nedenstående instruktioner nøje følges under service.

Følg iøvrigt instruktionerne i servicemanualen.

ADVARSEL!!

Under service må øjnene ikke komme nær objektiv-linsen på den optiske pick-up enhed. I tilfælde af at det er nødvendigt at kontrollere udsendelsen af laserlys, skal det ske i en afstand af mere end 25 cm fra den optiske pick-up.

1. Laser-dioe data

- Materiale: GaAlAs
- Bølgelængde: 780 nm
- Udstråling: Kontinuerlig
- Laseroutput: Max. 0,4 mW*
 - * Målt i 1,6 mm afstand fra overfladen af objektiv-linsen på den optiske pick-up enhed.
- Klassifikation: Klasse IIIb.

2. Adskil aldrig den optiske pick-up enhed under service, og juster ikke APC kredsløbet (Automatic Power Control). Hvis APC kredsløbet (incl. laserdioden) bryder ned, skal hele den optiske pick-up enhed (incl. APC printkortet) udskiftes.

LASER ADVARSEL MÆRKNING

Følgende mærkning findes indvendig i apparatet:

1. Advarsel Mærkning

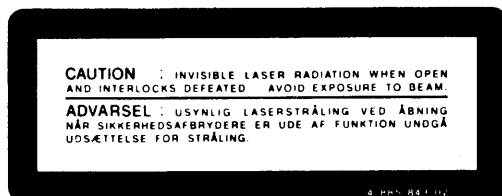

VAROITUS: Laite sisältää, laserdiodin, joka lähettää (näkyvätöntä) silmille vaarallista lasersäteilyä.

SECTION 1 GENERAL

This section is extracted from instruction manual.

1-1. LOCATION AND CONTROLS

Front Panel

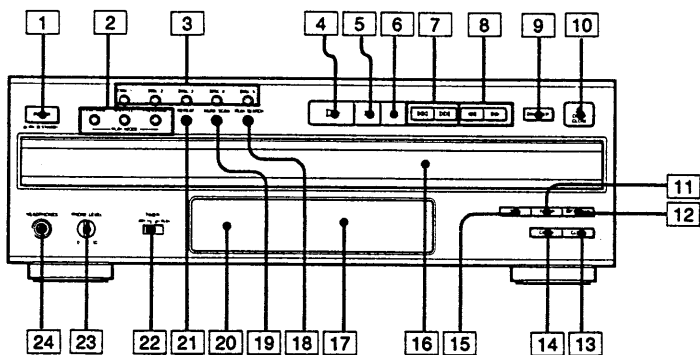

Refer to the pages indicated in () for details.

- 1 POWER switch (page 18)
- 2 PLAY MODE buttons
CONTINUE button (page 18)
SHUFFLE button (page 28)
PROGRAM button (page 30)
- 3 DISC 1-5 buttons (page 18)
- 4 ► (play) button (page 18)
- 5 || (pause) button (page 18)
- 6 ■ (stop) button (page 18)
- 7 ◀◀/▶▶ (AMS*) buttons (page 24)
- 8 ◀◀/▶▶ (manual search) buttons (page 26)
- 9 DISC SKIP button (page 18)
- 10 ▲ OPEN/CLOSE button (page 18)
- 11 FADER button (page 44)
- 12 EDIT/TIME FADE button (page 36)
- 13 CLEAR (program clear) button (page 34)
- 14 CHECK (program check) button (page 34)
- 15 TIME button (page 22)
- 16 Disc tray (page 18)
- 17 Display window
- 18 PEAK SEARCH button (page 48)
- 19 MUSIC SCAN button (page 42)
- 20 Remote sensor (CDP-C325M only)
- 21 REPEAT button (page 42)
- 22 TIMER switch (CDP-C325M only) (page 50)
- 23 PHONE LEVEL control (CDP-C325M only) (page 18)
- 24 HEADPHONES jack (CDP-C325M only)

* AMS is the abbreviation of Automatic Music Sensor.

Remote Commander

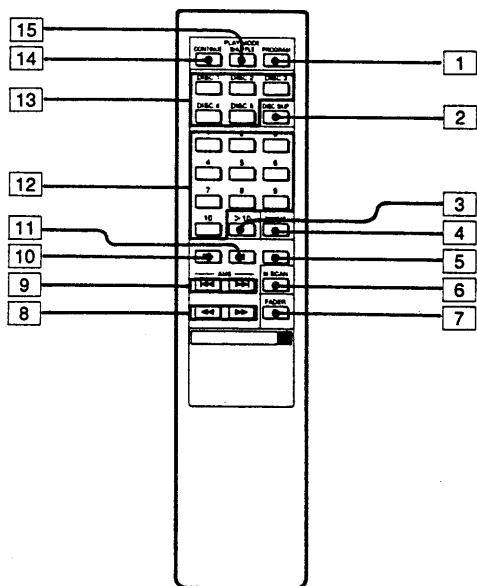

Refer to the pages indicated in () for details.

CDP-C325M only

- 1 PROGRAM button (page 30)
- 2 DISC SKIP button (page 18)
- 3 >10 (over 10) button (page 24)
- 4 REPEAT button (page 42)
- 5 ■ (stop) button (page 18)
- 6 MUSIC SCAN button (page 42)
- 7 FADER button (page 44)
- 8 ◀◀▶▶ (manual search) buttons (page 26)
- 9 ◀◀▶▶ (AMS) buttons (page 24)
- 10 ► (play) button (page 18)
- 10 || (pause) button (page 18)
- 11 Numeric buttons (1-10) (page 24)
- 13 DISC 1-5 buttons (page 18)
- 14 CONTINUE button (page 18)
- 15 SHUFFLE button (page 28)

SECTION 2 ELECTRICAL BLOCK CHECKING

Note :

1. CD Block basically constructed to operate without adjustment. Therefore, check each item in order given.
2. Use YEDS-18 disc (3-702-101-01) unless otherwise indicated.
3. Use the oscilloscope with more than 10MΩ impedance.
4. Clean an object lens by an applicator with neutral detergent when the signal level is low than specified value with the following checks.

S Curve Check

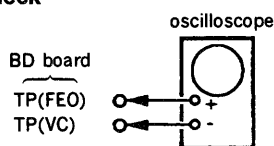

Procedure :

1. Connect oscilloscope to test point TP (FEO) on BD board.
2. Connect between test point TP (FES) and TP (VC) by lead wire.
3. Turned Power switch on and actuate the focus serch. (actuate the focus serch when disc table is moving in and out.)
4. Check the oscilloscope waveform (S curve) is symmetrical between A and B. And confirm peak to peak level within $3 \pm 1V_{p-p}$.

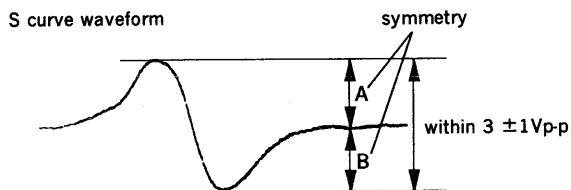

5. After check, remove the lead wire connected in step 2.
- Note :**
- Try to measure several times to make sure that the ratio of A : B or B : A is more than 10 : 7.
 - Take sweep time as long as possible and light up the brightness to obtain best waveform.

RF Level Check

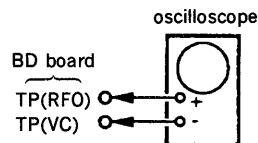

Procedure :

1. Connect oscilloscope to test point TP (RFO) on BD board.
2. Turn Power switch on.
3. Put disc (YEDS-18) in and playback.
4. Confirm that oscilloscope waveform is clear and check RF signal level is correct or not.

Note :

Clear RF signal waveform means that the shape “◇” can be clearly distinguished at the center of the waveform.

RF signal waveform

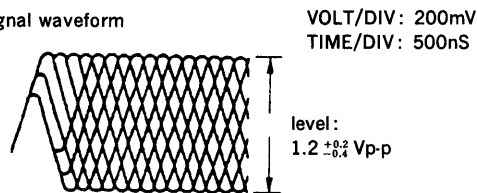

E-F Balance Check

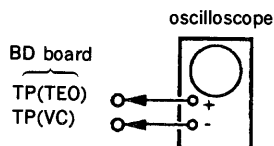

Procedure :

1. Connect test point TP (ADJ) to ground and TP (TES) to TP (VC) with lead wire.
2. Connect oscilloscope to test point TP (TEO) on BD board.
3. Turn Power switch on.
4. Put disc (YEDS-18) in and playback.
5. Confirm that the oscilloscope waveform is symmetrical on the top and bottom in relation to 0V, and check this level.

Traverse oscilloscope



6. Remove the lead wire connected in step 1.

RF PLL Free-run Frequency Check

Procedure :

1. Connect frequency counter to test point (PCK) with lead wire.

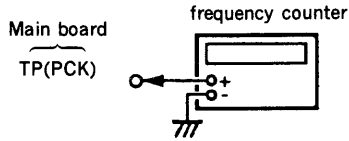

2. Turn Power switch on.
3. Confirm that reading on frequency counter is 4.3218MHz.

Focus/Tracking Gain

This gain has a margin, so even if it is slightly off.

There is no problem.

Therefore, do not perform, this adjustment.

Please note that it should be fixed to mechanical center position when you moved and do not know original position.

Adjustment Locations :

[BD Board]

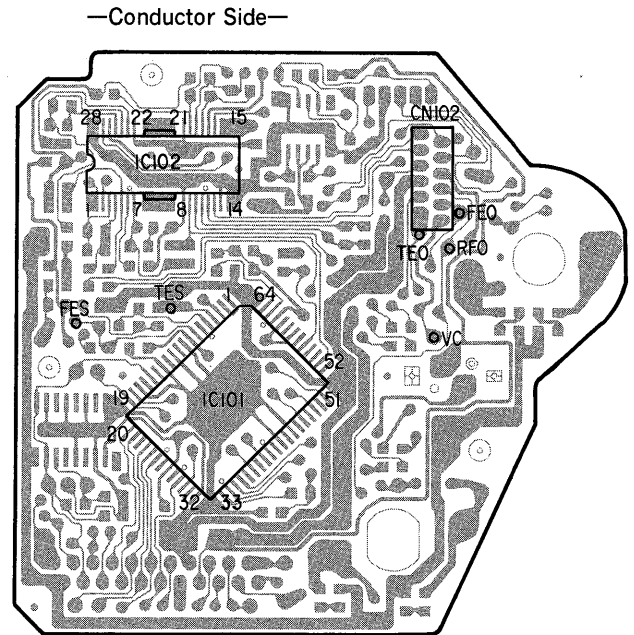

[MAIN Board]

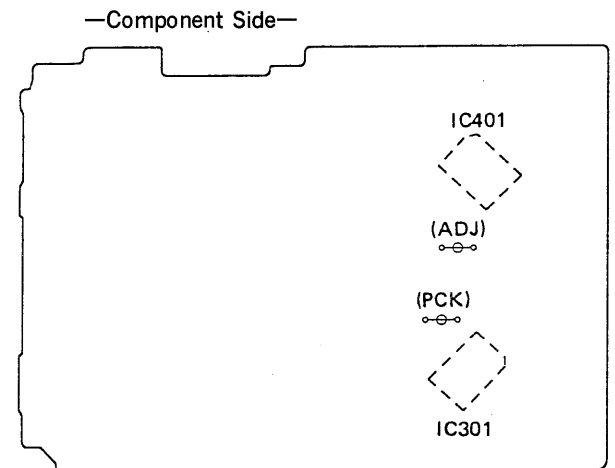

SECTION 3 DIAGRAMS

3-1. CIRCUIT BOARDS LOCATION

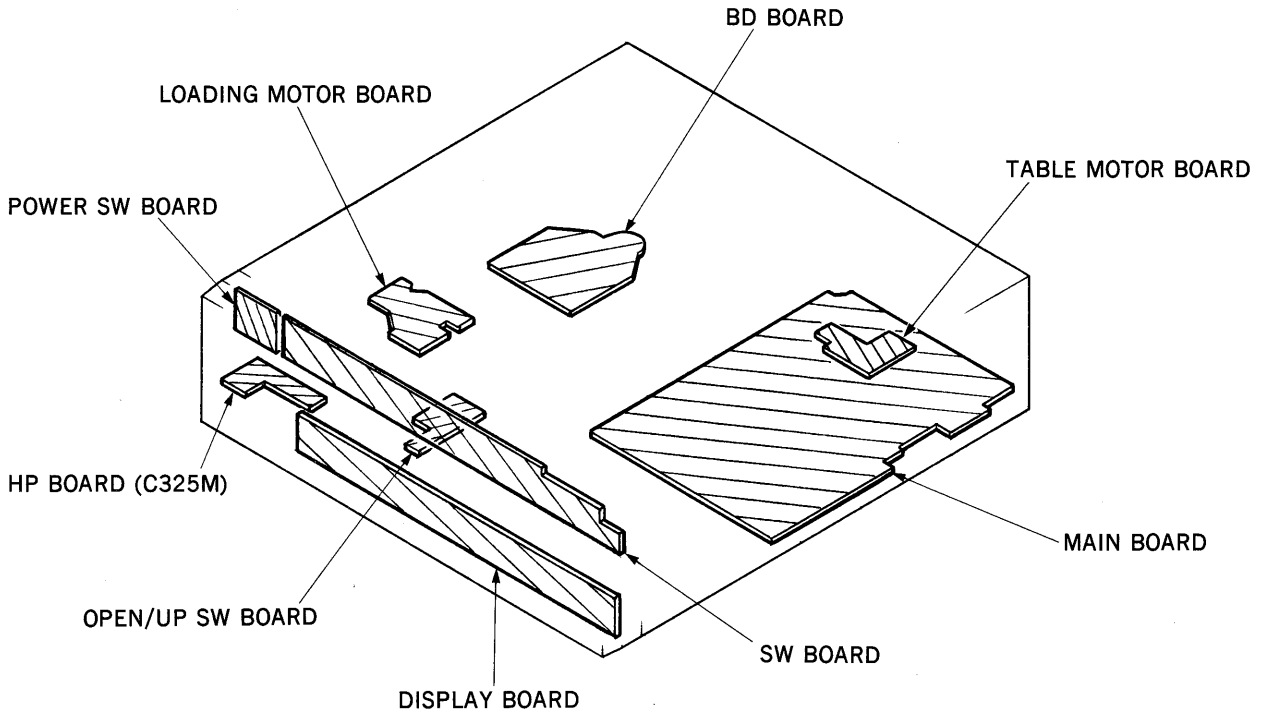

3-2. SEMICONDUCTOR LEAD LAYOUTS

BA6297AFP

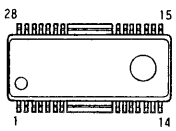

CXD2501Q

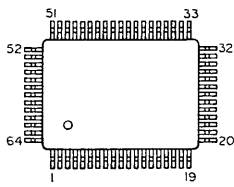

LA5602

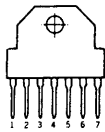

M5293L

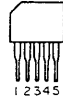

2SA1175-HFE

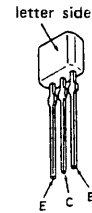

GP-1A521

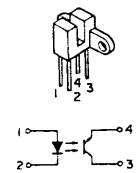

CXA1291P

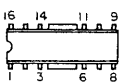

CXD2560M

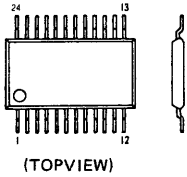

LA9215

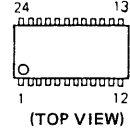

M5F7807L

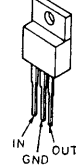

**DTA114ES
DTC114ES
DTC144ES**



**11ES2
1N4148M
RD8.2ES-B2**

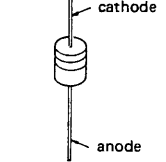

**CXD2500AQ
CXP50116-287Q
CXP50120-020Q**

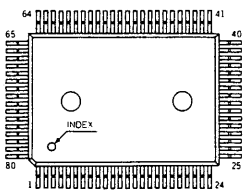

CXD2561BM

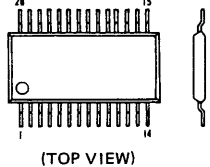

M5218AP

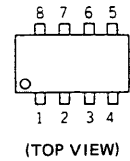

SBX1610-59

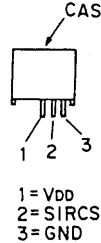

• IC Block Diagrams

IC101 CXD2501Q

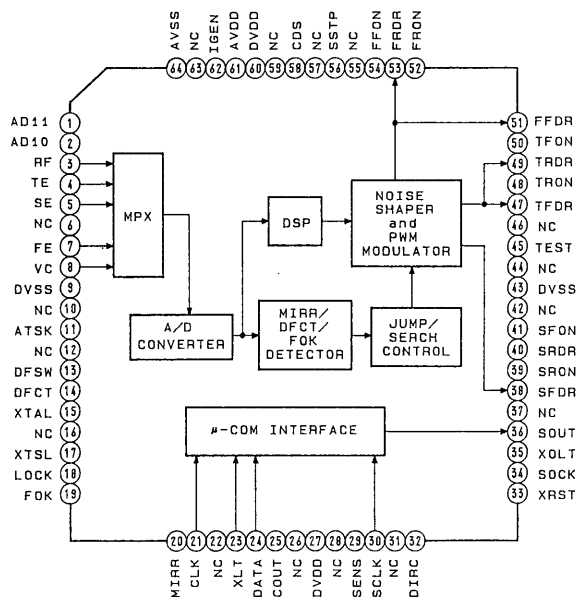

IC201 M5293L

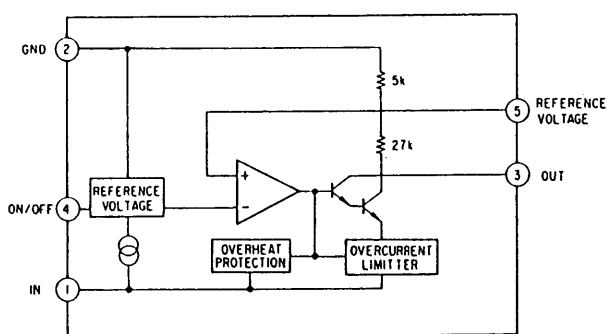

IC202 LA5602

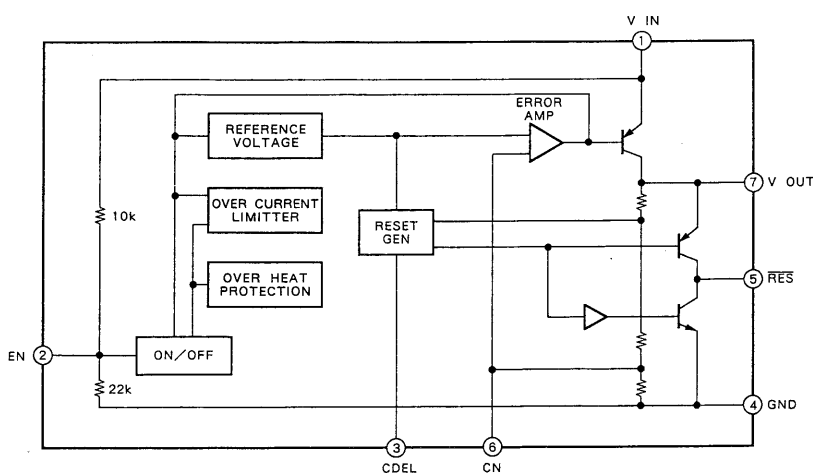

IC301 CXD2500AQ

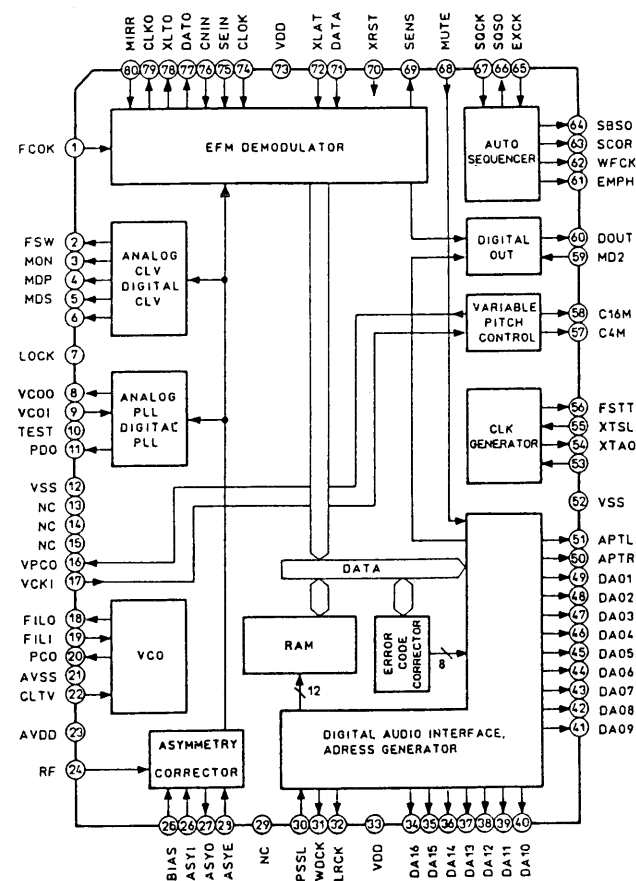

IC306 LA9215

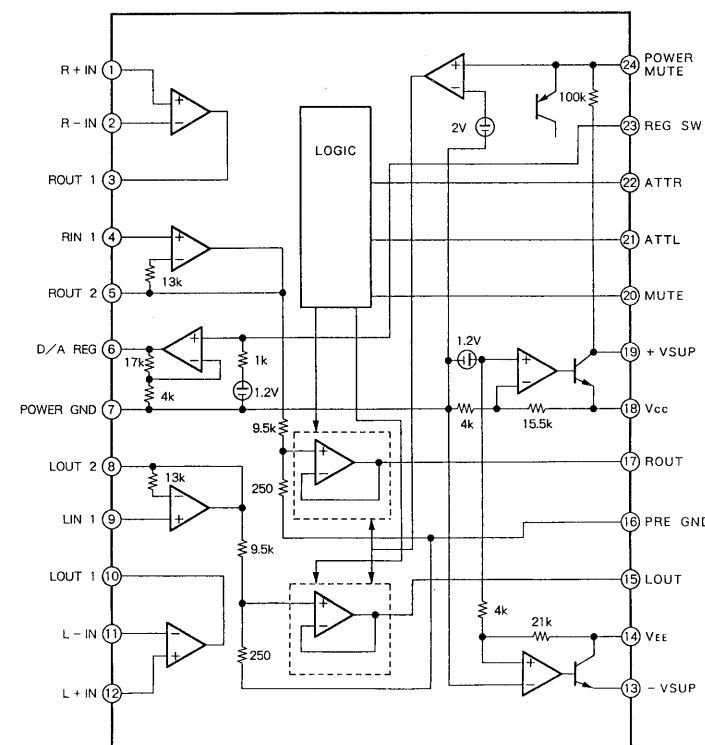

• Semiconductor Location

Ref. No.	Location
D201	D-23
D202	E-23
D203	C-23
D204	C-23
D205	D-23
D206	C-23
D207	C-20
D208	F-21
D385	I-23
D401	E-20
D701	G-30
IC101	C-28
IC102	B-28
IC201	D-23
IC202	D-22
IC204	D-22
IC301	H-18
IC302	I-20
IC303	H-21
IC306	H-24
IC401	D-18
IC402	C-19
IC501	F-22
IC601	I-10
Q201	E-22
Q302	F-23
Q303	G-22
Q304	G-23
Q305	G-23
Q401	C-17
Q403	F-20

3-3. PRINTED WIRING BOARDS • Refer to page 7 for Semiconductor Lead Layouts.

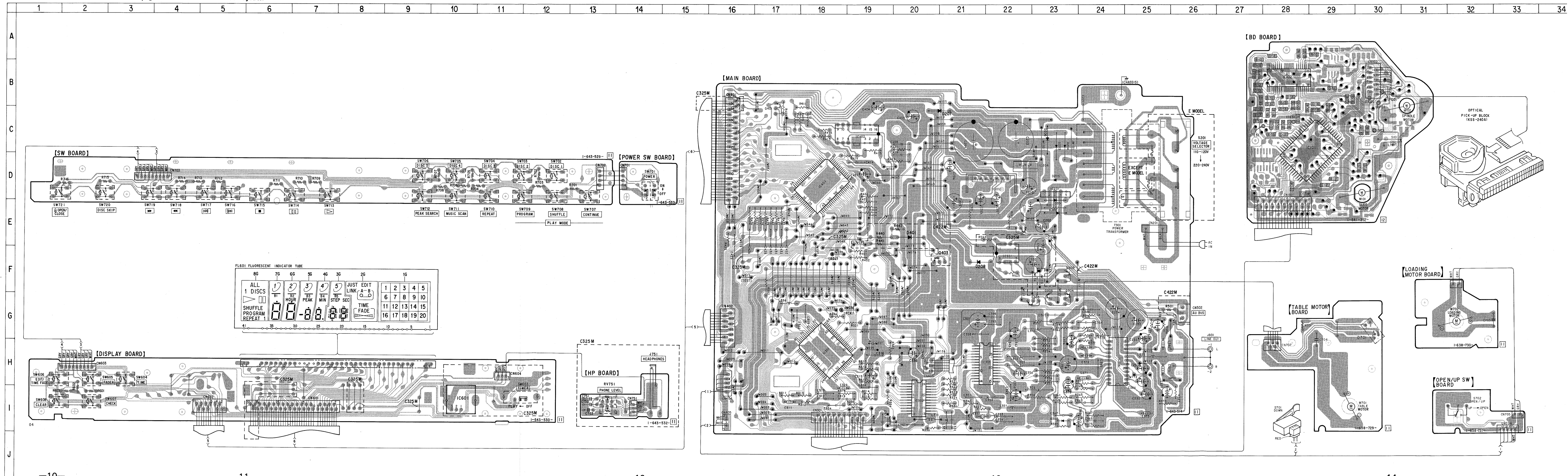

Note:
 ○ : parts extracted from the component side.
 ● : Through hole.
 ◐ : Pattern on the side which is seen.
 ◑ : Pattern of the rear side.

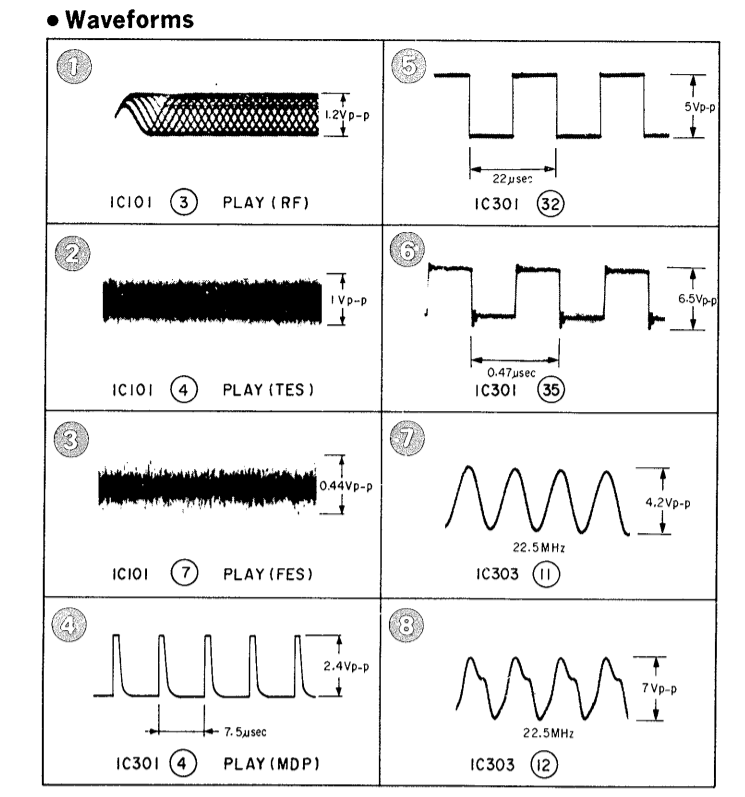
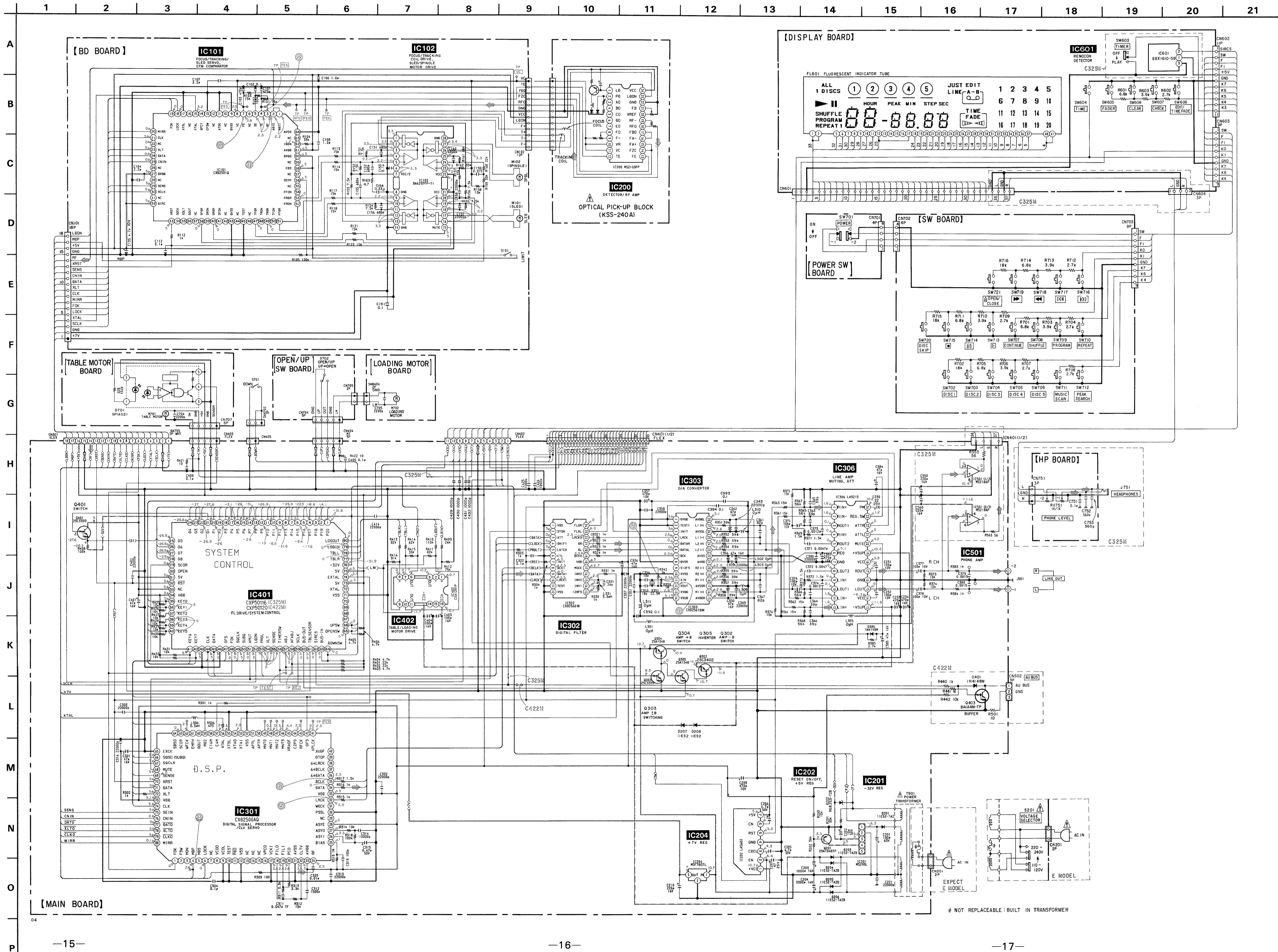

Note:

- All capacitors are in μF unless otherwise noted. pF : μF 50V or less are not indicated except for electrolytics and tantalums.
- All resistors are in Ω and $\frac{1}{2}\text{W}$ or less unless otherwise specified.

Note: The components identified by mark Δ or dotted line with mark Δ are critical for safety. Replace only with part number specified.

- --- : B+ Line
- --- : B- Line
- Voltage and waveforms are dc with respect to ground under no-signal conditions.
- Voltages are taken with a VOM (Input Impedance 10M Ω). Voltage variations may be noted due to normal production tolerances.
- Waveforms are taken with an oscilloscope. Voltage variations may be noted due to normal production tolerances.
- Circled numbers refer to waveforms.
- Signal path: --- : CD

SECTION 4 EXPLODED VIEWS

NOTE :

- The mechanical parts with no reference number in the exploded views are not supplied.
- Items marked "*" are not stocked since they are seldom required for routine service. Some delay should be anticipated when ordering these items.

- -XX, -X mean standardized parts, so they may have some differences from the original one.

- Color Indication of Appearance Parts
Example:

KNOB, BALANCE (WHITE)...(RED)

Parts Color Cabinet's Color

- Hardware (# mark) list is given in the last of this parts list.

The components identified by mark or dotted line with mark are critical for safety. Replace only with part number specified.

4-1. CABINET ASSEMBLY

- AUS : Australian model
EE : East European model

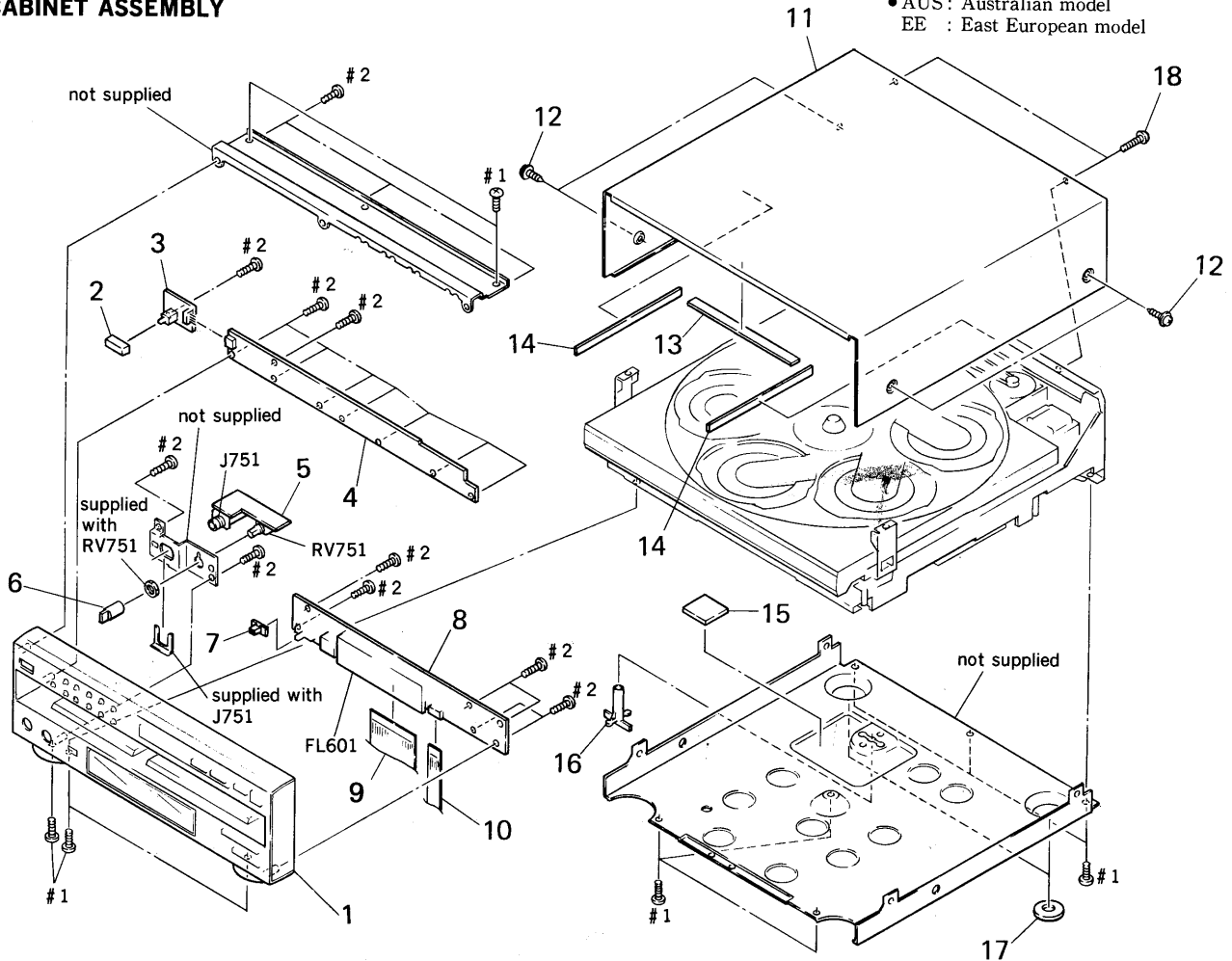

Ref. No.	Part No.	Description	Remark	Ref. No.	Part No.	Description	Remark
1	X-4942-549-1	PANEL ASSY. FRONT (C325M)		* 11	4-943-992-01	CASE (C325M)	
1	X-4942-550-1	PANEL ASSY. FRONT (C422M)		* 11	4-943-992-11	CASE (C422M)	
2	4-951-115-01	BUTTON (POWER) (C325M)		12	3-704-366-01	SCREW (CASE) (M3X8)	
2	4-951-115-11	BUTTON (POWER) (C422M)		* 13	4-929-557-01	CUSHION (PANEL)	
* 3	1-643-533-11	POWER SW BOARD		* 14	4-929-561-01	CUSHION (CASE) (C325M)	
* 4	1-643-529-11	SW BOARD		* 15	4-951-946-01	SHEET	
* 5	1-643-532-11	HP BOARD (C325M)		16	4-937-945-01	PLATE (TRANSPORT). LOCK	
6	4-922-531-11	KNOB (A TYPE). LOV (C325M)		17	4-924-410-01	FELT	
7	4-922-518-01	KNOB (TIMER) (C325M)		18	3-703-685-21	SCREW (+BV 3X8)	
* 8	1-643-530-11	DISPLAY BOARD		FL601	1-519-721-11	INDICATOR TUBE. FLUORESCENT	
9	1-690-847-11	WIRE (FLAT TYPE) (37 CORE) (C325M)		J751	1-691-878-11	JACK (LARGE TYPE) (HEAD PHONES) (C325M)	
9	1-690-848-11	WIRE (FLAT TYPE) (33 CORE) (C422M)		RV751	1-241-031-11	RES. VAR. CARBON 1K/1K (PHONE LEVEL) (C325M)	
10	1-690-849-11	WIRE (FLAT TYPE) (11 CORE)					

4-2. CHASSIS ASSEMBLY

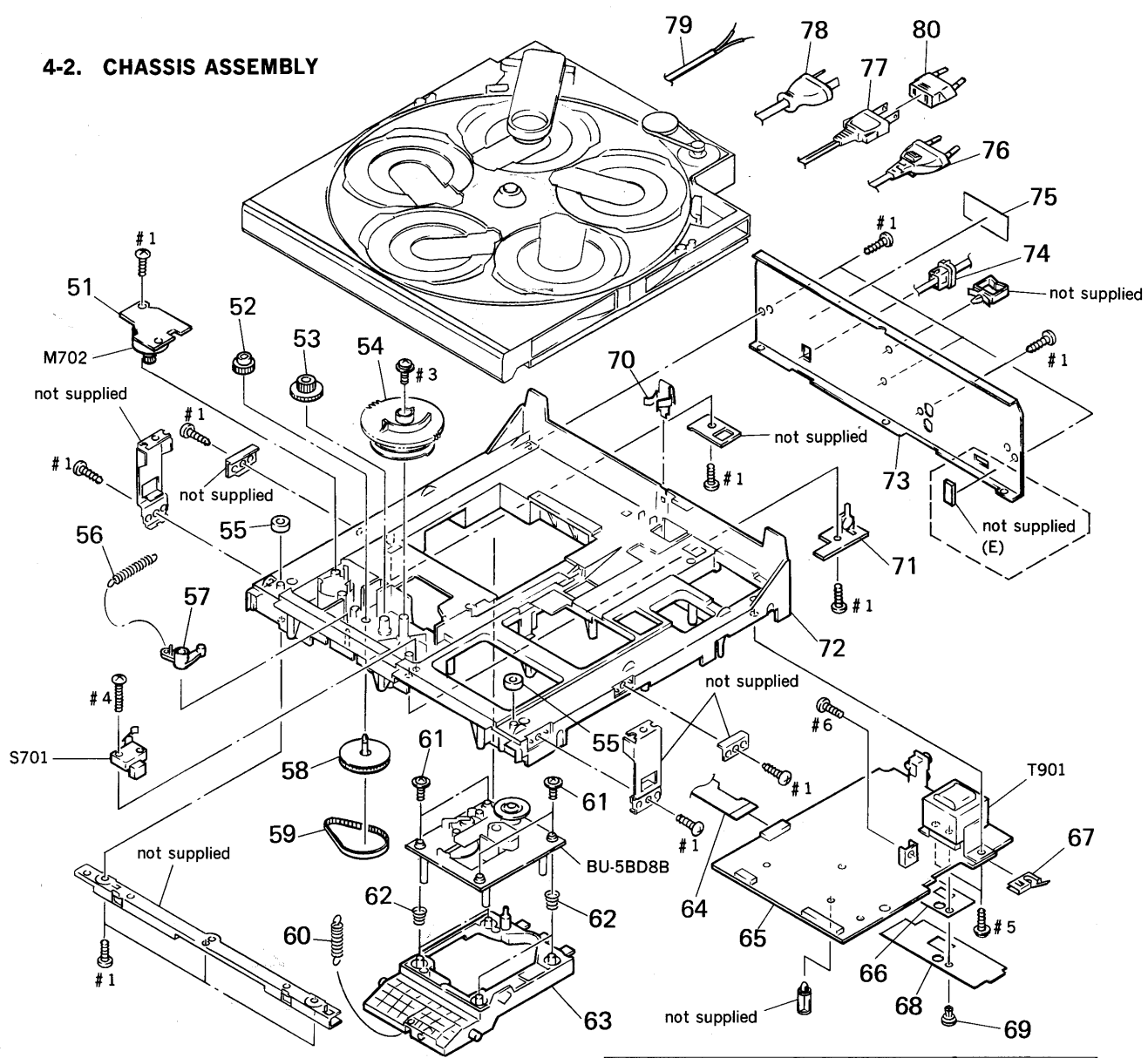

Note: The components identified by mark \triangle or dotted line with mark \triangle are critical for safety. Replace only with part number specified.

Ref. No.	Part No.	Description	Remark	Ref. No.	Part No.	Description	Remark
* 51	1-638-730-11	LOADING MOTOR BOARD		* 71	1-638-731-11	OPEN/UP SW BOARD	
52	4-934-375-01	GEAR (LOADING B)		* 72	4-943-997-01	CHASSIS	
53	4-934-381-01	GEAR (LOADING C)		* 73	4-949-862-01	PANEL, BACK (C325M:AEP)	
54	4-934-391-01	GEAR (LOADING A)		* 73	4-949-862-11	PANEL, BACK (C325M:UK, AUS)	
* 55	4-951-619-01	CUSHION (A)		* 73	4-949-862-21	PANEL, BACK (C325M:E)	
56	4-924-412-01	SPRING (B), TENSION		* 73	4-949-862-31	PANEL, BACK (C422M:AEP,EE)	
57	4-917-519-01	LEVER, SET		* 73	4-949-862-41	PANEL, BACK (C422M:UK, AUS)	
58	X-4941-529-1	PULLEY ASSY		* 73	4-949-862-51	PANEL, BACK (C422M:E)	
59	4-944-490-01	BELT (TIMING)		* 74	3-703-244-00	BUSHING (2104), CORD (AEP,EE,UK,AUS)	
60	4-937-911-01	SPRING, TENSION		* 74	3-703-571-11	BUSHING (S) (4516), CORD (E)	
61	4-933-134-01	SCREW (+PTPWH M2.6X6)		* 75	4-941-548-01	LABEL, CLASS 1	
62	4-949-385-01	SPRING (D), COIL		\triangle 76	1-575-651-21	CORD, POWER (AEP,EE)	
* 63	4-934-373-01	BRACKET (BU)		\triangle 77	1-575-653-21	CORD, POWER (E)	
64	1-694-003-11	JAMPER, FILM (WITH TARMINAL)		\triangle 78	1-574-358-11	CORD, POWER (WITH CONNECTOR) (C422M:AUS)	
* 65	A-4649-200-A	MAIN BOARD, COMPLETE (C422M:AEP,EE,UK,AUS)		\triangle 78	1-574-358-31	CORD, POWER (WITH CONNECTOR) (C325M:AUS)	
* 65	A-4649-208-A	MAIN BOARD, COMPLETE (C422M:E)		\triangle 79	1-558-946-21	CORD, POWER (C325M:UK)	
* 65	A-4649-209-A	MAIN BOARD, COMPLETE (C325M:AEP,UK,AUS)		\triangle 79	1-590-379-11	CORD, POWER (C422M:UK)	
* 65	A-4649-213-A	MAIN BOARD, COMPLETE (C325M:E)		\triangle 80	1-569-007-11	ADAPTER, CONVERSION 2P (C325M:E)	
* 66	4-951-933-01	SHEET, INSULATING (C325M:AEP,UK,AUS)		M702	A-4604-834-A	MOTOR ASSY, LOADING	
* 67	4-944-581-01	PLATE, GROUND		S701	1-572-713-11	SWITCH, PUSH (WITH CONNECTOR) (DOWN)	
* 68	4-944-178-01	SHEET (INSULATING)		\triangle T901	1-449-955-11	TRANSFORMER, POWER (EXCEPT E)	
69	3-531-576-11	RIVET		\triangle T901	1-449-956-11	TRANSFORMER, POWER (E)	
* 70	4-943-996-01	SPRING, LEAF					

4-3. TRAY ASSEMBLY

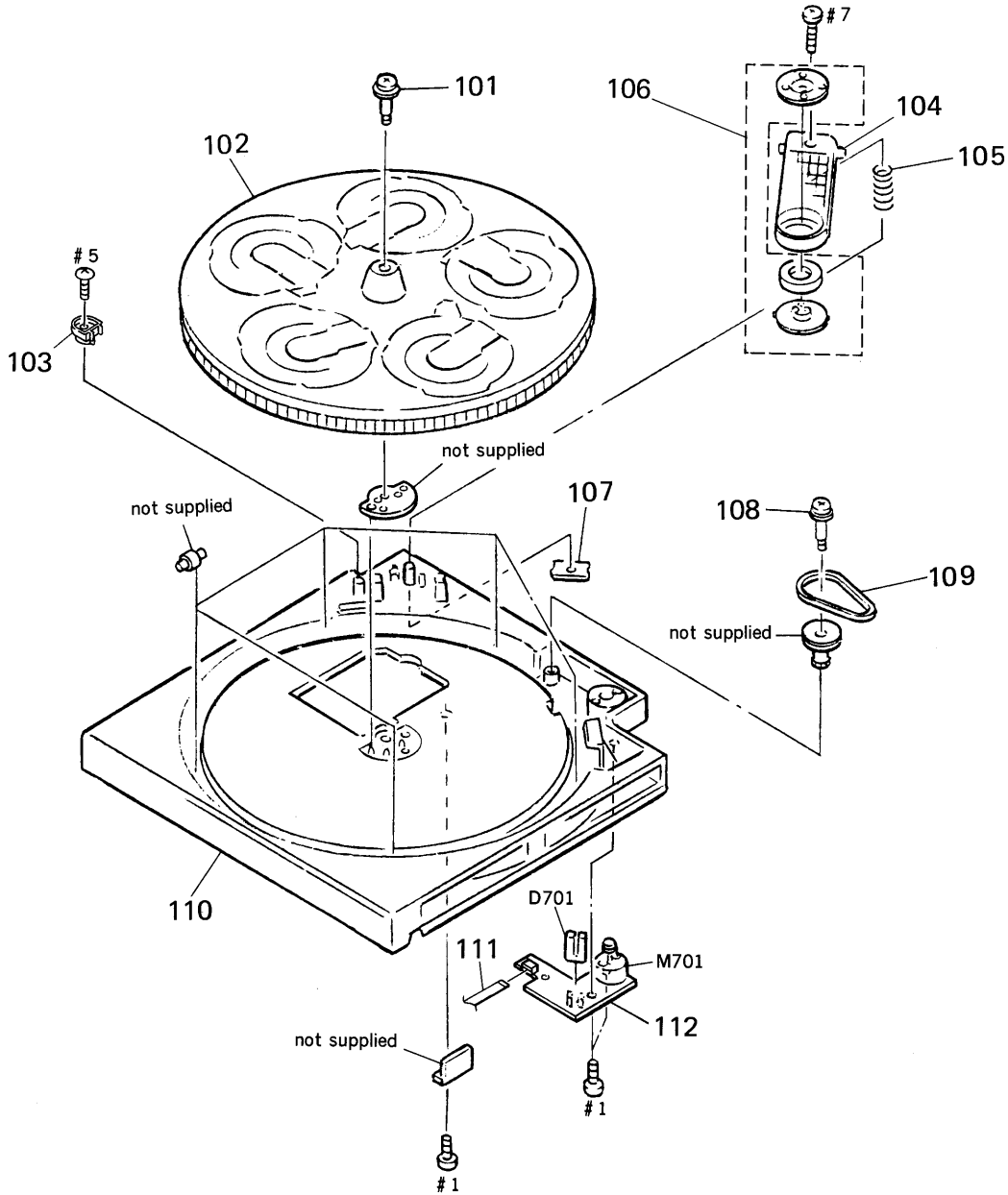

Ref. No.	Part No.	Description	Remark	Ref. No.	Part No.	Description	Remark
101	4-926-384-01	SCREW, STEP		109	4-926-399-01	BELT	
* 102	4-926-383-01	TABLE (B), DISK		110	4-951-121-01	TABLE (A), DISK (C325M)	
* 103	4-949-226-01	PLATE, LOCK		* 110	4-951-121-11	TABLE (A), DISK (C422M)	
* 104	4-930-506-02	BRACKET (PRESS PULLEY)		111	1-590-849-11	WIRE, FLAT TYPE (5 CORE)	
105	4-926-395-01	SPRING, COMPRESSION		* 112	1-638-729-11	TABLE MOTOR BOARD	
* 106	1-452-538-11	MAGNET		D701	8-719-970-19	DIODE GP1A521	
* 107	4-926-388-01	BRACKET (ADJUSTMENT)		M701	A-4604-585-A	MOTOR ASSY. ROTARY	
108	4-923-597-01	SCREW, STEP					

4-4. OPTICAL PICK-UP BLOCK (BU-5BD8)

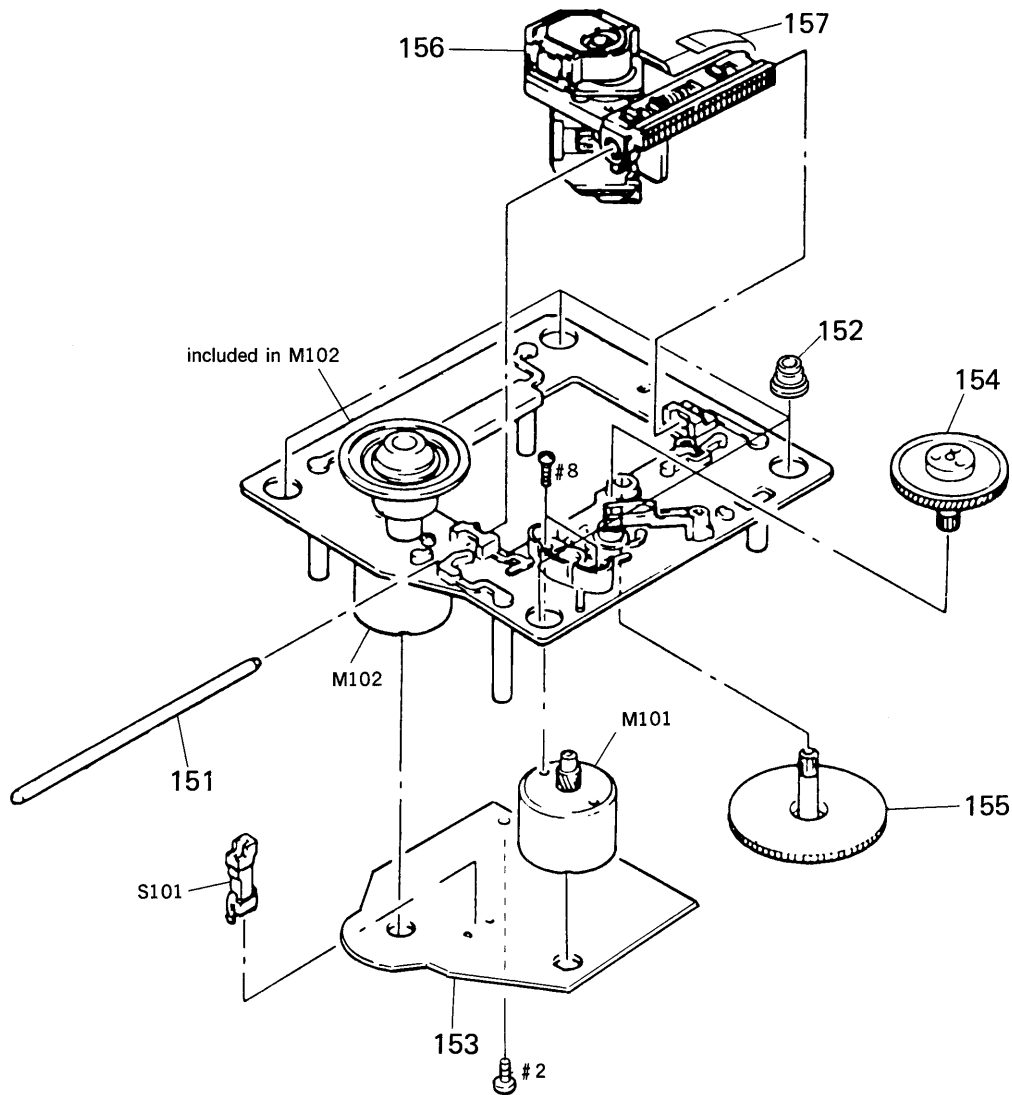

Note: The components identified by mark \triangle or dotted line with mark \triangle are critical for safety. Replace only with part number specified.

Ref. No.	Part No.	Description	Remark	Ref. No.	Part No.	Description	Remark
151	4-917-565-01	SHAFT, SLED		\triangle 156	8-848-144-11	DEVICE, OPTICAL KSS-240A	
152	4-951-940-01	INSULATOR (BU)		157	1-575-001-11	WIRE, FLAT TYPE (12 CORE)	
* 153	A-4649-199-A	BD BOARD, COMPLETE		M101	X-4917-504-1	MOTOR ASSY, SLED	
154	4-917-567-01	GEAR (M)		M102	X-4917-523-3	MOTOR ASSY, SPINDLE	
155	4-917-564-01	GEAR (P), FLATNESS		S101	1-572-085-11	SWITCH, LEAF (LIMIT)	

**SECTION 5
ELECTRICAL PARTS LIST**

BD **DISPLAY**
POWER SW **SW**

NOTE:

- Due to standardization, replacements in the parts list may be different from the parts specified in the diagrams or the components used on the set.
- -XX, -X mean standardized parts, so they may have some differences from the original one.
- Items marked "*" are not stocked since they are seldom required for routine service. Some delay should be anticipated when ordering these items.
- **CAPACITORS**
uF: μ F

- **RESISTORS**
All resistors are in ohms
METAL: Metal-film resistor
METAL OXIDE: Metal Oxide-film resistor
- F: nonflammable
- **COILS**
uH: μ H
- **SEMICONDUCTORS**
In each case, u: μ , for example:
uA...: μ A..., uPA...: μ PA...,
uPB...: μ PB..., uPC...: μ PC...,
uPD...: μ PD...

When indicating parts by reference number, please include the board name.

The components identified by mark Δ or dotted line with mark Δ are critical for safety. Replace only with part number specified.

- AUS: Australian model
- EE: East European model

Ref. No.	Part No.	Description	Remark	Ref. No.	Part No.	Description	Remark	
*	A-4649-199-A	BD BOARD, COMPLETE *****		R112	1-216-049-00	METAL CHIP 1K 5%	1/10W	
		< CAPACITOR >		R113	1-216-077-00	METAL CHIP 15K 5%	1/10W	
C101	1-163-005-11	CERAMIC CHIP 470PF	10%	50V	R114	1-216-077-00	METAL CHIP 15K 5%	1/10W
C102	1-163-038-00	CERAMIC CHIP 0.1uF		25V	R117	1-216-077-00	METAL CHIP 15K 5%	1/10W
C103	1-163-005-11	CERAMIC CHIP 470PF	10%	50V	R118	1-216-077-00	METAL CHIP 15K 5%	1/10W
C104	1-164-505-11	CERAMIC CHIP 2.2uF		16V	R121	1-216-077-00	METAL CHIP 15K 5%	1/10W
C105	1-135-155-21	TANTALUM CHIP 4.7uF	10%	16V	R122	1-216-077-00	METAL CHIP 15K 5%	1/10W
C106	1-164-346-11	CERAMIC CHIP 1uF		16V	R151	1-216-070-00	METAL CHIP 7.5K 5%	1/10W
C107	1-164-505-11	CERAMIC CHIP 2.2uF		16V	R152	1-216-070-00	METAL CHIP 7.5K 5%	1/10W
C108	1-164-346-11	CERAMIC CHIP 1uF		16V	R153	1-216-070-00	METAL CHIP 7.5K 5%	1/10W
C112	1-163-038-00	CERAMIC CHIP 0.1uF		25V	R154	1-216-070-00	METAL CHIP 7.5K 5%	1/10W
C151	1-163-007-11	CERAMIC CHIP 680PF	10%	50V	R155	1-216-070-00	METAL CHIP 7.5K 5%	1/10W
C152	1-163-007-11	CERAMIC CHIP 680PF	10%	50V	R156	1-216-070-00	METAL CHIP 7.5K 5%	1/10W
C153	1-163-038-00	CERAMIC CHIP 0.1uF		25V	R157	1-216-085-00	METAL CHIP 33K 5%	1/10W
C154	1-164-336-11	CERAMIC CHIP 0.33uF		25V	R158	1-216-076-00	METAL CHIP 13K 5%	1/10W
C155	1-163-007-11	CERAMIC CHIP 680PF	10%	50V	R159	1-216-085-00	METAL CHIP 33K 5%	1/10W
C156	1-163-007-11	CERAMIC CHIP 680PF	10%	50V	R160	1-216-081-00	METAL CHIP 22K 5%	1/10W
C157	1-163-037-11	CERAMIC CHIP 0.022uF	10%	25V	R161	1-216-093-00	METAL CHIP 68K 5%	1/10W
C158	1-163-037-11	CERAMIC CHIP 0.022uF	10%	25V	R162	1-216-085-00	METAL CHIP 33K 5%	1/10W
C159	1-163-023-00	CERAMIC CHIP 0.015uF	5%	50V	R163	1-216-308-00	METAL CHIP 4.7 5%	1/10W
C160	1-163-019-00	CERAMIC CHIP 0.0068uF	10%	50V				
C181	1-163-038-00	CERAMIC CHIP 0.1uF		25V				
		< CONNECTOR >						
CN101	1-568-861-11	SOCKET, CONNECTOR 18P						
CN102	1-568-795-11	SOCKET, CONNECTOR 12P						
		< IC >						
IC101	8-752-344-48	IC CXD2501Q						
IC102	8-759-071-79	IC BA6297AFP						
		< RESISTOR >						
R101	1-216-077-00	METAL CHIP 15K 5%	1/10W					
R102	1-216-097-00	METAL CHIP 100K 5%	1/10W					
R103	1-216-077-00	METAL CHIP 15K 5%	1/10W					
R104	1-216-085-00	METAL CHIP 33K 5%	1/10W					
R105	1-216-097-00	METAL CHIP 100K 5%	1/10W					
		< SWITCH >						
S101	1-572-085-11	SWITCH, LEAF (LIMIT)						

*	1-643-530-11	DISPLAY BOARD *****						
*	1-643-533-11	POWER SW BOARD *****						
*	1-643-529-11	SW BOARD *****						
		< CONNECTOR >						
* CN601	1-691-901-11	SOCKET, CONNECTOR (L TYPE) 33P (C422M)						
* CN601	1-691-902-11	SOCKET, CONNECTOR (L TYPE) 37P (C325M)						
* CN602	1-691-889-11	SOCKET, CONNECTOR (L TYPE) 11P						
* CN604	1-568-941-11	PIN, CONNECTOR 3P (C325M)						
* CN701	1-565-295-11	PLUG, CONNECTOR 4P						
* CN702	1-565-480-11	CONNECTOR, BOARD TO BOARD 4P						
* CN703	1-568-947-11	PIN, CONNECTOR 9P						

DISPLAY

POWER SW

SW

HP

LOADING MOTOR

OPEN/UP SW

TABLE MOTOR

Ref. No.	Part No.	Description	Remark
		< IC >	
IC601	8-741-100-48	IC SBX1610-59 (C325M)	
		< FLUORESCENT INDICATOR >	
FL601	1-519-721-11	INDICATOR TUBE, FLUORESCENT	
		< RESISTOR >	
R601	1-249-427-11	CARBON 6.8K 5% 1/4W	
R602	1-249-422-11	CARBON 2.7K 5% 1/4W	
R603	1-249-424-11	CARBON 3.9K 5% 1/4W	
R701	1-249-427-11	CARBON 6.8K 5% 1/4W	
R702	1-249-432-11	CARBON 18K 5% 1/4W	
R703	1-249-424-11	CARBON 3.9K 5% 1/4W	
R704	1-249-422-11	CARBON 2.7K 5% 1/4W	
R705	1-249-427-11	CARBON 6.8K 5% 1/4W	
R706	1-249-424-11	CARBON 3.9K 5% 1/4W	
R707	1-249-422-11	CARBON 2.7K 5% 1/4W	
R708	1-249-422-11	CARBON 2.7K 5% 1/4W	
R709	1-249-422-11	CARBON 2.7K 5% 1/4W	
R710	1-249-424-11	CARBON 3.9K 5% 1/4W	
R711	1-249-427-11	CARBON 6.8K 5% 1/4W	
R712	1-249-422-11	CARBON 2.7K 5% 1/4W	
R713	1-249-424-11	CARBON 3.9K 5% 1/4W	
R714	1-249-427-11	CARBON 6.8K 5% 1/4W	
R715	1-249-432-11	CARBON 18K 5% 1/4W	
R716	1-249-432-11	CARBON 18K 5% 1/4W	
		< SWITCH >	
SW603	1-570-157-51	SWITCH, SLIDE (TIMER) (C325M)	
SW604	1-554-303-21	SWITCH, TACTILE (TIME)	
SW605	1-554-303-21	SWITCH, TACTILE (FADER)	
SW606	1-554-303-21	SWITCH, TACTILE (EDIT/TIME FADE)	
SW607	1-554-303-21	SWITCH, TACTILE (CHECK)	
SW608	1-554-303-21	SWITCH, TACTILE (CLEAR)	
SW701	1-572-714-11	SWITCH, PUSH (POWER)	
SW702	1-554-303-21	SWITCH, TACTILE (DISC 1)	
SW703	1-554-303-21	SWITCH, TACTILE (DISC 2)	
SW704	1-554-303-21	SWITCH, TACTILE (DISC 3)	
SW705	1-554-303-21	SWITCH, TACTILE (DISC 4)	
SW706	1-554-303-21	SWITCH, TACTILE (DISC 5)	
SW707	1-554-303-21	SWITCH, TACTILE (CONTINUE)	
SW708	1-554-303-21	SWITCH, TACTILE (SHUFFLE)	
SW709	1-554-303-21	SWITCH, TACTILE (PROGRAM)	
SW710	1-554-303-21	SWITCH, TACTILE (REPEAT)	
SW711	1-554-303-21	SWITCH, TACTILE (MUSIC SCAN)	
SW712	1-554-303-21	SWITCH, TACTILE (PEAK SEARCH)	
SW713	1-554-303-21	SWITCH, TACTILE (>)	
SW714	1-554-303-21	SWITCH, TACTILE (□)	

Ref. No.	Part No.	Description	Remark
SW715	1-554-303-21	SWITCH, TACTILE (■)	
SW716	1-554-303-21	SWITCH, TACTILE (⋈)	
SW717	1-554-303-21	SWITCH, TACTILE (⋈)	
SW718	1-554-303-21	SWITCH, TACTILE (◀)	
SW719	1-554-303-21	SWITCH, TACTILE (▶)	
SW720	1-554-303-21	SWITCH, TACTILE (DISC SKIP)	
SW721	1-554-303-21	SWITCH, TACTILE (△) OPEN/CLOSE	

*	1-643-532-11	HP BOARD (C325M)	

		< CAPACITOR >	
C751	1-164-159-11	CERAMIC 0.1uF 50V (C325M)	
C752	1-162-291-31	CERAMIC 560PF 10% 50V (C325M)	
C753	1-162-291-31	CERAMIC 560PF 10% 50V (C325M)	
		< JACK >	
J751	1-691-878-11	JACK (LARGE TYPE) (HEADPHONES) (C325M)	
		< VARIABLE RESISTOR >	
RV751	1-241-031-11	RES. VAR. CARBON 1K/1K (PHONE LEVEL) (C325M)	

*	1-638-730-11	LOADING MOTOR BOARD	

*	1-638-731-11	OPEN/UP SW BOARD	

*	1-638-729-11	TABLE MOTOR BOARD	

		< CAPACITOR >	
C704	1-161-375-00	CERAMIC 0.0022uF 20% 50V	
C705	1-161-375-00	CERAMIC 0.0022uF 20% 50V	
		< CONNECTOR >	
* CN705	1-573-383-11	PIN, CONNECTOR (PC BOARD) 2P	
* CN707	1-573-044-11	SOCKET, CONNECTOR 5P	
		< DIODE >	
D701	8-719-970-19	DIODE GP1A521	
		< RESISTOR >	
R701	1-249-416-11	CARBON 820 5% 1/4W	

LOADING MOTOR

OPEN/UP SW

TABLE MOTOR

MAIN

Ref. No.	Part No.	Description	Remark
< SWITCH >			
S702	1-571-300-21	SWITCH, ROTARY (OPEN/UP)	

*	A-4649-200-A	MAIN BOARD, COMPLETE (C422M:AEP,EE,UK,AUS)	
*	A-4649-208-A	MAIN BOARD, COMPLETE (C422M:E)	
*	A-4649-209-A	MAIN BOARD, COMPLETE (C325M:AEP,UK,AUS)	
*	A-4649-213-A	MAIN BOARD, COMPLETE (C325M:E)	

	7-682-548-04	SCREW +BVTT 3X8 (S)	
< CAPACITOR >			
C201	1-124-572-11	ELECT 100uF	20% 63V
C202	1-126-059-11	ELECT 10uF	20% 50V
C203	1-124-360-00	ELECT 1000uF	20% 16V
C204	1-124-887-00	ELECT 3300uF	20% 16V
C205	1-126-163-11	ELECT 4.7uF	20% 50V
C206	1-126-163-11	ELECT 4.7uF	20% 50V
C207	1-124-910-11	ELECT 47uF	20% 50V
C209	1-124-997-11	ELECT 470uF	20% 10V
C210	1-126-024-11	ELECT 220uF	20% 16V
C221	1-161-494-00	CERAMIC 0.022uF	25V
C230	1-126-049-11	ELECT 22uF	20% 25V
C231	1-124-994-11	ELECT 100uF	20% 10V
C232	1-124-994-11	ELECT 100uF	20% 10V
C233	1-126-012-11	ELECT 470uF	20% 16V
C234	1-126-012-11	ELECT 470uF	20% 16V
C301	1-126-022-11	ELECT 47uF	20% 16V
C302	1-161-494-00	CERAMIC 0.022uF	25V
C303	1-161-494-00	CERAMIC 0.022uF	25V
C304	1-164-159-11	CERAMIC 0.1uF	50V
C311	1-130-491-00	MYLAR 0.047uF	5% 50V
C312	1-161-374-11	CERAMIC 0.0015uF	20% 50V
C313	1-161-494-00	CERAMIC 0.022uF	25V
C314	1-162-306-11	CERAMIC 0.01uF	20% 16V
C315	1-126-300-11	ELECT 0.47uF	20% 50V
C316	1-161-494-00	CERAMIC 0.022uF	25V
C319	1-162-282-31	CERAMIC 100PF	10% 50V
C320	1-130-483-00	MYLAR 0.01uF	5% 50V
C322	1-164-159-11	CERAMIC 0.1uF	50V
C331	1-162-208-31	CERAMIC 24PF	5% 50V
C336	1-126-022-11	ELECT 47uF	20% 16V
C337	1-161-494-00	CERAMIC 0.022uF	25V
C342	1-126-022-11	ELECT 47uF	20% 16V
C343	1-161-494-00	CERAMIC 0.022uF	25V
C349	1-161-494-00	CERAMIC 0.022uF	25V
C350	1-126-022-11	ELECT 47uF	20% 16V
C351	1-161-494-00	CERAMIC 0.022uF	25V

Ref. No.	Part No.	Description	Remark
C353	1-162-205-31	CERAMIC 18PF	5% 50V
C354	1-162-205-31	CERAMIC 18PF	5% 50V
C355	1-161-494-00	CERAMIC 0.022uF	25V
C356	1-126-022-11	ELECT 47uF	20% 16V
C357	1-124-997-11	ELECT 470uF	20% 10V
C358	1-161-494-00	CERAMIC 0.022uF	25V
C361	1-162-280-31	CERAMIC 82PF	10% 50V
C363	1-162-213-31	CERAMIC 39PF	5% 50V
C364	1-162-213-31	CERAMIC 39PF	5% 50V
C365	1-162-213-31	CERAMIC 39PF	5% 50V
C366	1-162-213-31	CERAMIC 39PF	5% 50V
C367	1-162-280-31	CERAMIC 82PF	10% 50V
C371	1-130-479-00	MYLAR 0.0047uF	5% 50V
C372	1-130-479-00	MYLAR 0.0047uF	5% 50V
C373	1-130-472-00	MYLAR 0.0012uF	5% 50V
C374	1-130-472-00	MYLAR 0.0012uF	5% 50V
C375	1-124-994-11	ELECT 100uF	20% 10V
C376	1-124-994-11	ELECT 100uF	20% 10V
C377	1-124-994-11	ELECT 100uF	20% 10V
C378	1-124-994-11	ELECT 100uF	20% 10V
C379	1-130-473-00	MYLAR 0.0015uF	5% 50V
C380	1-130-473-00	MYLAR 0.0015uF	5% 50V
C384	1-126-022-11	ELECT 47uF	20% 16V
C385	1-126-022-11	ELECT 47uF	20% 16V
C390	1-161-494-00	CERAMIC 0.022uF	25V
C391	1-124-997-11	ELECT 470uF	20% 10V
C392	1-164-159-11	CERAMIC 0.1uF	50V
C393	1-164-159-11	CERAMIC 0.1uF	50V
C394	1-164-159-11	CERAMIC 0.1uF	50V
C401	1-126-022-11	ELECT 47uF	20% 16V
C402	1-161-494-00	CERAMIC 0.022uF	25V
C403	1-126-023-11	ELECT 100uF	20% 16V
C404	1-126-023-11	ELECT 100uF	20% 16V
C408	1-164-159-11	CERAMIC 0.1uF	50V
C409	1-164-159-11	CERAMIC 0.1uF	50V
C414	1-161-494-00	CERAMIC 0.022uF	25V
C425	1-162-294-31	CERAMIC 0.001uF	10% 50V
C426	1-162-294-31	CERAMIC 0.001uF	10% 50V
C429	1-162-294-31	CERAMIC 0.001uF	10% 50V
C430	1-162-294-31	CERAMIC 0.001uF	10% 50V
C431	1-162-294-31	CERAMIC 0.001uF	10% 50V
C432	1-162-294-31	CERAMIC 0.001uF	10% 50V
C550	1-126-024-11	ELECT 220uF	20% 16V
		(C325M)	
C560	1-126-024-11	ELECT 220uF	20% 16V
		(C325M)	
< CONNECTOR >			
* CN201	1-573-047-11	PIN, CONNECTOR (PC BOARD) 2P	

MAIN

Ref. No.	Part No.	Description	Remark	Ref. No.	Part No.	Description	Remark
* CN301	1-691-895-11	SOCKET, CONNECTOR (L TYPE) 18P				< TRANSISTOR >	
* CN401	1-691-901-11	SOCKET, CONNECTOR (L TYPE) 33P (C422M)					
* CN401	1-691-902-11	SOCKET, CONNECTOR (L TYPE) 37P (C325M)		Q201	8-729-119-76	TRANSISTOR 2SA1175-HFE	
* CN402	1-691-889-11	SOCKET, CONNECTOR (L TYPE) 11P		Q302	8-729-900-80	TRANSISTOR DTC114ES	
* CN403	1-568-824-11	SOCKET, CONNECTOR 5P		Q303	8-729-900-89	TRANSISTOR DTC144ES	
				Q304	8-729-900-61	TRANSISTOR DTA114ES	
* CN404	1-568-943-11	PIN, CONNECTOR 5P		Q305	8-729-900-61	TRANSISTOR DTA114ES	
* CN502	1-565-561-11	PIN, CONNECTOR 3P (AU BUS) (C422M)					
		< DIODE >		Q401	8-729-900-89	TRANSISTOR DTC144ES	
D201	8-719-200-82	DIODE 11ES2		Q403	8-729-900-80	TRANSISTOR DTC114ES (C422M)	
D202	8-719-110-08	DIODE RD8. 2ES-B2				< RESISTOR >	
D203	8-719-200-82	DIODE 11ES2		R201	1-249-435-11	CARBON 33K 5% 1/4W	
D204	8-719-200-82	DIODE 11ES2		R202	1-249-438-11	CARBON 56K 5% 1/4W	
D205	8-719-200-82	DIODE 11ES2		R203	1-249-429-11	CARBON 10K 5% 1/4W	
D206	8-719-200-82	DIODE 11ES2		R301	1-249-417-11	CARBON 1K 5% 1/4W	
D207	8-719-200-82	DIODE 11ES2		R302	1-249-417-11	CARBON 1K 5% 1/4W	
D208	8-719-200-82	DIODE 11ES2		R303	1-249-417-11	CARBON 1K 5% 1/4W	
D385	8-719-987-63	DIODE 1N4148M		R304	1-249-417-11	CARBON 1K 5% 1/4W	
D401	8-719-987-63	DIODE 1N4148M (C422M)		R306	1-249-413-11	CARBON 470 5% 1/4W	
		< IC >		R309	1-249-405-11	CARBON 100 5% 1/4W	
IC201	8-759-633-42	IC M5293L		R311	1-249-423-11	CARBON 3.3K 5% 1/4W	
IC202	8-759-061-65	IC LA5602		R312	1-249-429-11	CARBON 10K 5% 1/4W	
IC204	8-759-604-86	IC M5F7807L		R313	1-249-423-11	CARBON 3.3K 5% 1/4W	
IC301	8-752-337-26	IC CXD2500AQ		R314	1-249-429-11	CARBON 10K 5% 1/4W	
IC302	8-752-342-65	IC CXD2560M		R315	1-249-417-11	CARBON 1K 5% 1/4W	
IC303	8-752-351-19	IC CXD2561BM		R316	1-249-417-11	CARBON 1K 5% 1/4W	
IC306	8-759-061-66	IC LA9215		R317	1-249-419-11	CARBON 1.5K 5% 1/4W	
IC401	8-752-837-03	IC CXP50120-020Q (C422M)		R318	1-249-441-11	CARBON 100K 5% 1/4W	
IC401	8-752-837-01	IC CXP50116-287Q (C325M)		R319	1-247-903-00	CARBON 1M 5% 1/4W	
IC402	8-759-821-32	IC CXA1291P		R321	1-249-417-11	CARBON 1K 5% 1/4W	
IC501	8-759-634-51	IC M5218AP (C325M)		R322	1-249-417-11	CARBON 1K 5% 1/4W	
		< JACK >		R323	1-249-417-11	CARBON 1K 5% 1/4W	
J501	1-569-442-11	JACK, PIN 2P (LINE OUT)		R324	1-249-417-11	CARBON 1K 5% 1/4W	
		< COIL >		R330	1-249-417-11	CARBON 1K 5% 1/4W	
L301	1-412-473-21	INDUCTOR 0uH		R331	1-249-417-11	CARBON 1K 5% 1/4W	
L302	1-412-473-21	INDUCTOR 0uH		R342	1-249-417-11	CARBON 1K 5% 1/4W	
L303	1-412-473-21	INDUCTOR 0uH		R351	1-249-436-11	CARBON 39K 5% 1/4W	
L305	1-412-473-21	INDUCTOR 0uH		R352	1-249-436-11	CARBON 39K 5% 1/4W	
L306	1-412-297-11	INDUCTOR 3.3uH		R353	1-249-436-11	CARBON 39K 5% 1/4W	
L309	1-412-473-21	INDUCTOR 0uH		R354	1-249-436-11	CARBON 39K 5% 1/4W	
L310	1-412-473-21	INDUCTOR 0uH		R355	1-249-436-11	CARBON 39K 5% 1/4W	
L311	1-412-473-21	INDUCTOR 0uH		R356	1-249-436-11	CARBON 39K 5% 1/4W	
L331	1-412-297-11	INDUCTOR 3.3uH		R357	1-249-436-11	CARBON 39K 5% 1/4W	
				R358	1-249-436-11	CARBON 39K 5% 1/4W	
				R359	1-247-903-00	CARBON 1M 5% 1/4W	
				R361	1-249-431-11	CARBON 15K 5% 1/4W	
				R362	1-249-431-11	CARBON 15K 5% 1/4W	
				R363	1-249-431-11	CARBON 15K 5% 1/4W	
				R364	1-249-431-11	CARBON 15K 5% 1/4W	

MAIN

Ref. No.	Part No.	Description	Remark
R365	1-249-438-11	CARBON	56K 5% 1/4W
R366	1-249-438-11	CARBON	56K 5% 1/4W
R367	1-249-438-11	CARBON	56K 5% 1/4W
R368	1-249-438-11	CARBON	56K 5% 1/4W
R369	1-249-419-11	CARBON	1.5K 5% 1/4W
R370	1-249-419-11	CARBON	1.5K 5% 1/4W
R371	1-249-419-11	CARBON	1.5K 5% 1/4W
R372	1-249-419-11	CARBON	1.5K 5% 1/4W
R373	1-249-429-11	CARBON	10K 5% 1/4W
R374	1-249-429-11	CARBON	10K 5% 1/4W
R375	1-249-429-11	CARBON	10K 5% 1/4W
R376	1-249-429-11	CARBON	10K 5% 1/4W
R383	1-249-417-11	CARBON	1K 5% 1/4W
R384	1-249-417-11	CARBON	1K 5% 1/4W
R385	1-249-422-11	CARBON	2.7K 5% 1/4W
R401	1-249-433-11	CARBON	22K 5% 1/4W
R402	1-249-433-11	CARBON	22K 5% 1/4W
R403	1-249-425-11	CARBON	4.7K 5% 1/4W
R404	1-249-425-11	CARBON	4.7K 5% 1/4W
R405	1-249-425-11	CARBON	4.7K 5% 1/4W
R406	1-249-425-11	CARBON	4.7K 5% 1/4W
R408	1-249-441-11	CARBON	100K 5% 1/4W
R409	1-247-864-11	CARBON	24K 5% 1/4W
R410	1-247-880-11	CARBON	110K 5% 1/4W
R411	1-249-440-11	CARBON	82K 5% 1/4W
R412	1-247-876-11	CARBON	75K 5% 1/4W
R413	1-249-440-11	CARBON	82K 5% 1/4W
R414	1-247-874-11	CARBON	62K 5% 1/4W
R415	1-249-435-11	CARBON	33K 5% 1/4W
R416	1-247-878-00	CARBON	91K 5% 1/4W
R421	1-249-393-11	CARBON	10 5% 1/4W
R422	1-249-393-11	CARBON	10 5% 1/4W
R425	1-249-429-11	CARBON	10K 5% 1/4W
R426	1-249-429-11	CARBON	10K 5% 1/4W
R427	1-249-429-11	CARBON	10K 5% 1/4W
R428	1-249-429-11	CARBON	10K 5% 1/4W
R429	1-249-429-11	CARBON	10K 5% 1/4W
R430	1-249-429-11	CARBON	10K 5% 1/4W
R431	1-249-429-11	CARBON	10K 5% 1/4W
R432	1-249-429-11	CARBON	10K 5% 1/4W
R440	1-249-417-11	CARBON	1K 5% 1/4W (C422M)
R441	1-249-417-11	CARBON	1K 5% 1/4W (C422M)
R442	1-249-429-11	CARBON	10K 5% 1/4W (C422M)
R501	1-249-393-11	CARBON	10 5% 1/4W (C422M)
R553	1-249-402-11	CARBON	56 5% 1/4W (C325M)
R563	1-249-402-11	CARBON	56 5% 1/4W (C325M)

Ref. No.	Part No.	Description	Remark
< SWITCH >			
△S201	1-571-722-11	SWITCH, VOLTAGE SELECTION (VOLTAGE SELECTOR) (E)	
< CRYSTAL >			
X351	1-579-314-11	VIBRATOR, CRYSTAL (22.5MHz)	

MISCELLANEOUS			

9	1-690-847-11	WIRE (FLAT TYPE) (37 CORE) (C325M)	
9	1-690-848-11	WIRE (FLAT TYPE) (33 CORE) (C422M)	
10	1-690-849-11	WIRE (FLAT TYPE) (11 CORE)	
64	1-694-003-11	JAMPER, FILM (WITH TARMINAL)	
△76	1-575-651-21	CORD, POWER (AEP,EE)	
△77	1-575-653-21	CORD, POWER (E)	
△78	1-574-358-11	CORD, POWER (WITH CONNECTOR) (C422M:AUS)	
△78	1-574-358-31	CORD, POWER (WITH CONNECTOR) (C325M:AUS)	
△79	1-558-946-21	CORD, POWER (C325M:UK)	
△79	1-590-379-11	CORD, POWER (C422M:UK)	
△80	1-569-007-11	ADAPTER, CONVERSION 2P (C325M:E)	
* 106	1-452-538-11	MAGNET	
111	1-590-849-11	WIRE, FLAT TYPE (5 CORE)	
△156	8-848-144-11	DEVICE, OPTICAL KSS-240A	
157	1-575-001-11	WIRE, FLAT TYPE (12 CORE)	
M101	X-4917-504-1	MOTOR ASSY. SLED	
M102	X-4917-523-3	MOTOR ASSY. SPINDLE	
M701	A-4604-585-A	MOTOR ASSY. ROTARY	
M702	A-4604-834-A	MOTOR ASSY. LOADING	
S701	1-572-713-11	SWITCH, PUSH (WITH CONNECTOR) (DOWN)	
△T901	1-449-955-11	TRANSFORMER, POWER (EXCEPT E)	
△T901	1-449-956-11	TRANSFORMER, POWER (E)	

Note: The components identified by mark △ or dotted line with mark △ are critical for safety. Replace only with part number specified.

Ref. No.	Part No.	Description	Remark
ACCESSORIES & PACKING MATERIALS			

	1-558-271-11	CORD, CONNECTION (C325M:AEP)	
	1-558-271-11	CORD, CONNECTION (C422M:AEP,EE)	
	1-693-053-11	REMOTE COMMANDER (RM-D325) (C325M)	
	2-181-754-01	COVER, BATTERY (C325M)	
	3-754-847-11	MANUAL, INSTRUCTION (ENGLISH, FRENCH, SPANISH, PORTUGUESE)	
	3-754-847-41	MANUAL, INSTRUCTION (GERMAN, DUTCH, SWEDISH, ITALIAN) (AEP,EE)	
*	4-944-040-01	CUSHION (FRONT)	
*	4-944-041-01	CUSHION (REAR)	
*	4-951-269-11	INDIVIDUAL CARTON (C325M)	
*	4-951-269-21	INDIVIDUAL CARTON (C422M:AEP,EE,AUS)	

HARDWARE LIST

#1	7-685-646-79	SCREW +BVTP 3X8 TYPE2 N-S
#2	7-685-134-19	SCREW +BTP 2.6X8 TYPE2 N-S
#3	7-682-661-09	SCREW +PSW 4X8
#4	7-685-136-19	SCREW +P 2.6X12 TYPE2 NON-SLIT
#5	7-685-647-79	SCREW, TAPPING
#6	7-682-548-04	SCREW +BVTT 3X8 (S)
#7	7-682-554-04	SCREW +B 3X25
#8	7-621-255-15	SCREW +P 2X3