

CDP-C515

SERVICE MANUAL

US Model
Canadian Model

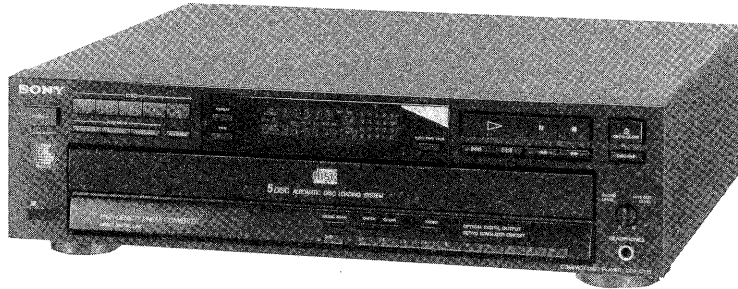

Model Name Using Similar Mechanism	CDP-C312M
CD Mechanism Type	CDM16E2-5BD3
Optical Pick-Up Block Type	BU-5BD3

SPECIFICATIONS

System	Compact disc digital audio system
Laser	Semiconductor laser ($\lambda=780$ nm) Emission duration: continuous
Laser output	Max. 44.6 μ W* * This output is the value measured at a distance of about 200 mm from the objective lens surface on the Optical Pick-up Block.
Frequency response	2 Hz – 20 kHz (± 0.5 dB)
Signal to noise ratio	More than 100 dB
Dynamic range	More than 98 dB
Harmonic distortion	Less than 0.005% (1 kHz)
Channel separation	More than 100 dB (1 kHz)
Wow and flutter	Below measurable limit

Outputs

LINE OUT (FIXED) (phone jacks)	Output level 2 V (at 50 kilohms) Load impedance over 10 kilohms
LINE OUT (VARIABLE) (phono jacks)	Output level max. 2 V (at 50 kilohms) Load impedance over 10 kilohms
DIGITAL OUT (OPTICAL) (optical output connector)	Wave length 660 nm Output level – 18 dBm
HEADPHONES (stereo phone jack)	Output level max. 10 mW Load impedance 32 ohms

General

Power requirements	120 V AC, 60 Hz
Power consumption	12 W
Dimensions	Approx. 430×125×385 mm (w/h/d) (17×5×15 ¹ / ₄ inches) not including projecting parts and controls
Weight	Approx. 6 kg (13 lbs 4 oz), net

Remote commander

Remote control system	RM-D515 Infrared control
Power requirements	3 V DC with two batteries size AA (IEC esignation R6)

Supplied accessories

Connecting cord (1)
(2 phono plugs ↔ 2 phono plugs)
Remote commander (1)
Size AA batteries (2)
Operating Manual (1)

Optional accessory

Audio Optical connecting cord POC-15

Design and specifications subject to change without notice.

COMPACT DISK PLAYER
SONY®

Note on the Transit Key

The transit key on the bottom exterior of the unit protects the optical system against shock during transportation. Before operating the CD player, be sure to remove the key by following the instructions on the label, and store it in a safe place.

When transporting the unit, replace the key in its original hole and lock it in place.

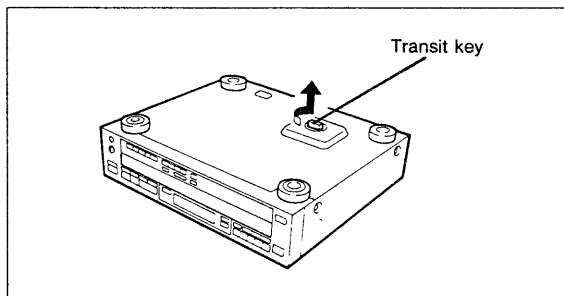





TABLE OF CONTENTS

<u>Section</u>	<u>Title</u>	<u>Page</u>	<u>Section</u>	<u>Title</u>	<u>Page</u>
1. GENERAL			5. EXPLODED VIEWS		
1-1.	Location of Controls	5	5-1.	Front Panel and Case Assemblies	21
2. DISASSEMBLY			5-2.	Disc Tray Assembly	22
2-1.	Removal of Front Panel and Case Assemblies	6	5-3.	Chassis Assembly	23
2-2.	Removal of Disc Tray Assembly	6	5-4.	Optical Pick-up Block Assembly (BU-5BD3)	24
2-3.	Removal of Optical Pick-up Block Assembly	6	6. ELECTRICAL PARTS LIST		25
3. ELECTRICAL BLOCK CHECKING		7			
4. DIAGRAMS					
4-1.	Circuit Boards Location	9			
4-2.	Semiconductor Lead Layouts	9			
4-3.	IC Block Diagrams	10			
4-4.	Printed Wiring Boards	12			
4-5.	Schematic Diagram	17			

SAFETY-RELATED COMPONENT WARNING!!
 COMPONENTS IDENTIFIED BY MARK  OR DOTTED LINE WITH MARK  ON THE SCHEMATIC DIAGRAMS AND IN THE PARTS LIST ARE CRITICAL TO SAFE OPERATION. REPLACE THESE COMPONENTS WITH SONY PARTS WHOSE PART NUMBERS APPEAR AS SHOWN IN THIS MANUAL OR IN SUPPLEMENTS PUBLISHED BY SONY.

ATTENTION AU COMPOSANT AYANT RAPPORT À LA SÉCURITÉ!
 LES COMPOSANTS IDENTIFIÉS PAR UNE MARQUE  SUR LES DIAGRAMMES SCHÉMATIQUES ET LA LISTE DES PIÈCES SONT CRITIQUES POUR LA SÉCURITÉ DE FONCTIONNEMENT. NE REMPLACER CES COMPOSANTS QUE PAR DES PIÈCES SONY DONT LES NUMÉROS SONT DONNÉS DANS CE MANUEL OU DANS LES SUPPLÉMENTS PUBLIÉS PAR SONY.

MODEL IDENTIFICATION

—Model Number Label—

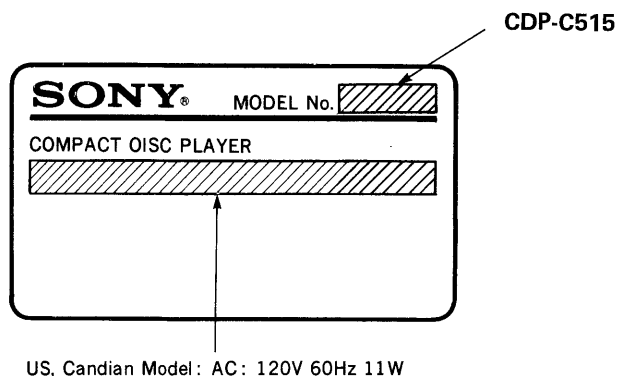
NOTES ON HANDLING THE OPTICAL PICK-UP BLOCK OR BASE UNIT

The laser diode in the optical pick-up block may suffer electrostatic breakdown because of the potential difference generated by the charged electrostatic load, etc. on clothing and the human body.

During repair, pay attention to electrostatic breakdown and also use the procedure in the printed matter which is included in the repair parts.

The flexible board is easily damaged and should be handled with care.

NOTES ON LASER DIODE EMISSION CHECK

The laser beam on this model is concentrated so as to be focused on the disc reflective surface by the objective lens in the optical pick-up block. Therefore, when checking the laser diode emission, observe from more than 30cm away from the objective lens.

SAFETY CHECK-OUT

After correcting the original service problem, perform the following safety check before releasing the set to the customer:

Check the antenna terminals, metal trim, "metallized" knobs, screws, and all other exposed metal parts for AC leakage. Check leakage as described below.

LEAKAGE TEST

The AC leakage from any exposed metal part to earth ground and from all exposed metal parts to any exposed metal part having a return to chassis, must not exceed 0.5 mA (500 microamperes). Leakage current can be measured by any one of three methods.

1. A commercial leakage tester, such as the Simpson 229 or RCA WT-540A. Follow the manufacturers' instructions to use these instruments.
2. A battery-operated AC milliammeter. The Data Precision 245 digital multimeter is suitable for this job.
3. Measuring the voltage drop across a resistor by means of a VOM or battery-operated AC voltmeter. The "limit" indication is 0.75 V, so analog meters must have an accurate low-voltage scale. The Simpson 250 and Sanwa SH-63Trd are examples of a passive VOM that is suitable. Nearly all battery operated digital multimeters that have a 2V AC range are suitable. (See Fig. A)

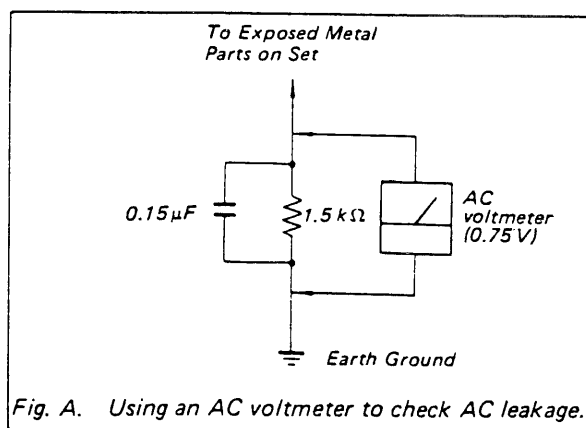

PROTECTION OF EYES FROM LASER BEAM DURING SERVICING

This set employs a laser. Therefore, be sure to follow carefully the instructions below when servicing.

CAUTION

Use of controls or adjustments or performance of procedures other than those specified herein may result in hazardous radiation exposure.

1. Laser Diode Properties

- Material: GaAlAs
- Wavelength: 780 nm
- Emission Duration: continuous
- Laser Output Power: less than 44.6 μ W*
 - * This output is the value measured at a distance of 200 mm from the objective lens surface on the Optical Pick-up Block.

2. During service, do not take the Optical Pick-up Block apart, and do not adjust the APC circuit. If there is a breakdown in the APC circuit (including laser diode), replace the entire Optical Pick-up Block (including APC board).

BESKYTTELSE AF ØJNE MOD LASERSTRÅLING UNDER SERVICE

I dette apparat anvendes laserlys. Derfor skal nedenstående instruktioner nøje følges under service.

Følg iøvrigt instruktionerne i servicemanualen.

ADVARSEL!!

Under service må øjnene ikke komme nær objektiv-linsen på den optiske pick-up enhed. I tilfælde af at det er nødvendigt at kontrollere udsendelsen af laserlys, skal det ske i en afstand af mere end 25 cm fra den optiske pick-up.

1. Laser-dioe data

- Materiale: GaAlAs
- Bølgelængde: 780 nm
- Udstråling: Kontinuerlig
- Laseroutput: Max. 0,4 mW*
 - * Målt i 1,6 mm afstand fra overfladen af objektiv-linsen på den optiske pick-up enhed.
- Klassifikation: Klasse IIIb.

2. Adskil aldrig den optiske pick-up enhed under service, og juster ikke APC kredsløbet (Automatic Power Control). Hvis APC kredsløbet (incl. laserdioden) bryder ned, skal hele den optiske pick-up enhed (incl. APC printkortet) udskiftes.

LASER ADVARSEL MÆRKNING

Følgende mærkning findes indvendig i apparatet:

1. Advarsel Mærkning

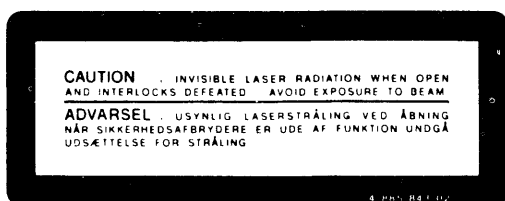

VAROITUS: Laite sisältää, laserdiodin, joka lähettää (näkyvätöntä) silmille vaarallista lasersäteilyä.

SECTION 1 GENERAL

1-1. LOCATION OF CONTROLS

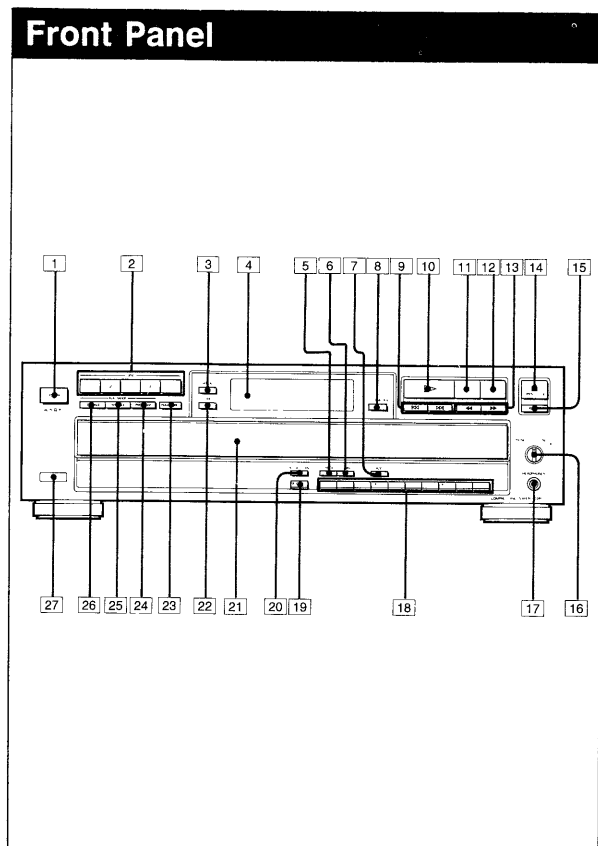

- 1 POWER switch
- 2 DISC 1-5 buttons
- 3 REPEAT button
- 4 Display window
- 5 CHECK (program check) button
- 6 CLEAR (program clear) button
- 7 FADER button
- 8 EDIT/TIME FADE button
- 9 ◀▶ (AMS*) buttons
- 10 ▶ (play) button
- 11 || (pause) button
- 12 ■ (stop) button
- 13 ◀▶▶▶ (manual search) buttons
- 14 ▲ OPEN/CLOSE button
- 15 DISC SKIP button
- 16 LINE OUT/PHONE LEVEL control
- 17 HEADPHONES jack
- 18 Numeric buttons (1-10)
- 19 > 10 (OVER 10) button
- 20 MUSIC SCAN button
- 21 Disc tray
- 22 TIME button
- 23 PEAK SEARCH button
- 24 PROGRAM button
- 25 SHUFFLE button
- 26 CONTINUE button
- 27 Remote sensor

* AMS is the abbreviation of Automatic Music Sensor.

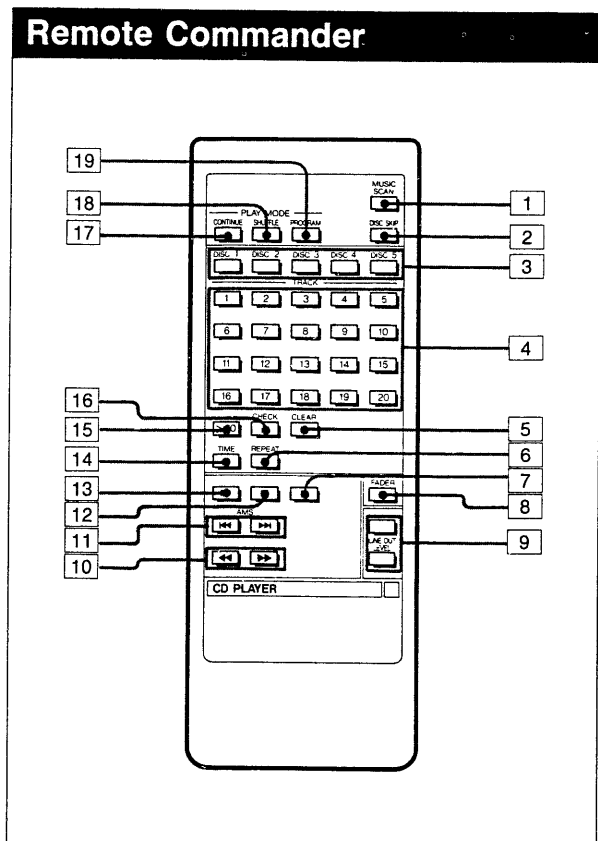

- 1 MUSIC SCAN button
- 2 DISC SKIP button
- 3 DISC 1-5 buttons
- 4 Numeric buttons
- 5 CLEAR (program clear) button
- 6 REPEAT button
- 7 ■ (stop) button
- 8 FADER button
- 9 LINE OUT LEVEL buttons
- 10 ◀▶▶▶ (manual search) buttons
- 11 ◀▶▶▶ (AMS) buttons
- 12 || (pause) button
- 13 ▶ (play) button
- 14 TIME button
- 15 > 20 (over 20) button
- 16 CHECK (program check) button
- 17 CONTINUE button
- 18 SHUFFLE button
- 19 PROGRAM button

SECTION 2 DISASSEMBLY

2-1. REMOVAL OF FRONT PANEL AND CASE ASSEMBLIES

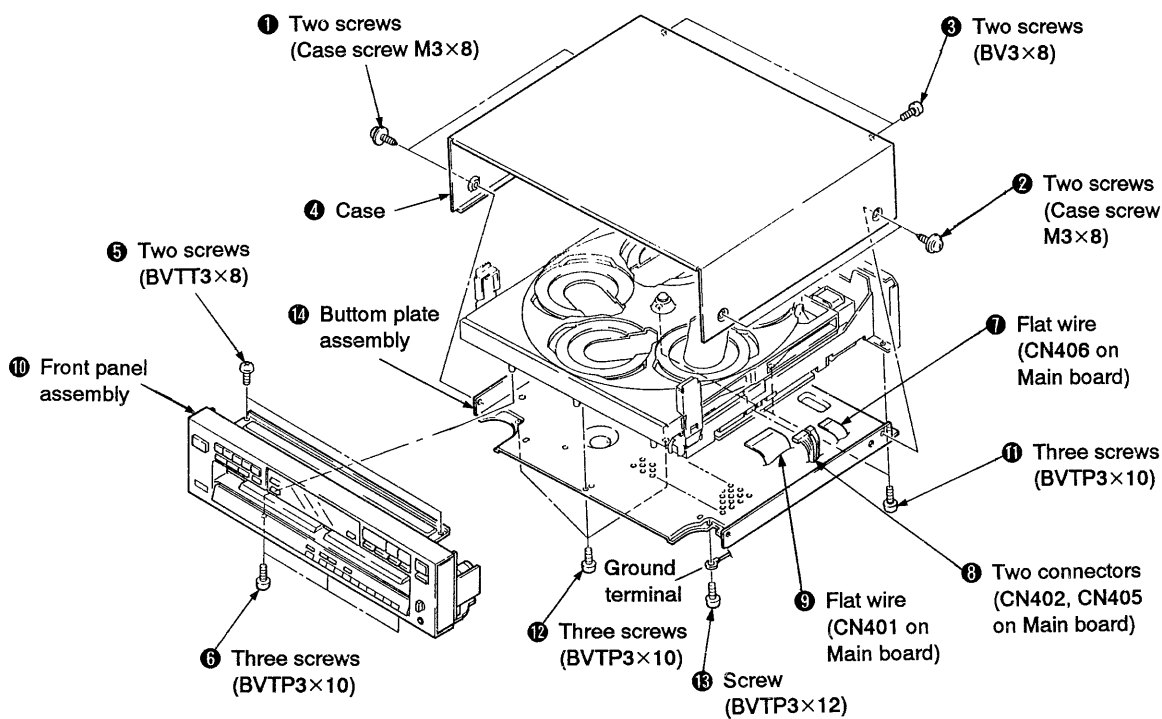

2-2. REMOVAL OF DISC TRAY ASSEMBLY

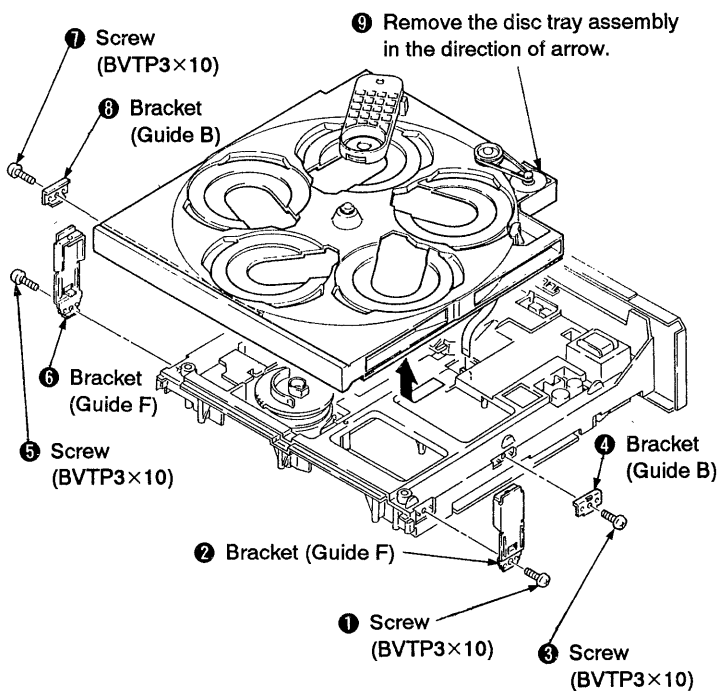

2-3. REMOVAL OF OPTICAL PICK-UP BLOCK ASSEMBLY

1) Replace the set up side down.

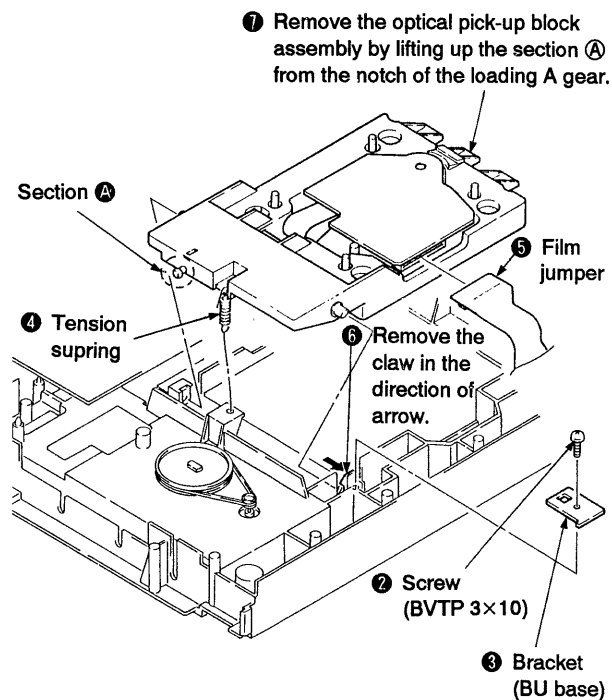

SECTION 3 ELECTRICAL BLOCK CHECKING

Note :

1. CD Block basically constructed to operate without adjustment. Therefore, check each item in order given.
2. Use YEDS-18 disc (3-702-101-01) unless otherwise indicated.
3. Use the oscilloscope with more than $10M\Omega$ impedance.
4. Clean an object lens by an applicator with neutral detergent when the signal level is low than specified value with the following checks.

S Curve Check

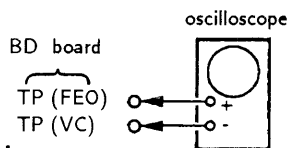

Procedure :

1. Connect oscilloscope to test point TP (FEO) on BD board.
2. Connect between test point TP (FES) and TP (VC) by lead wire.
3. Turned Power switch on and actuate the focus serch. (actuate the focus serch when disc table is moving in and out.)
4. Check the oscilloscope waveform (S curve) is symmetrical between A and B. And confirm peak to peak level within $3 \pm 1V_{p-p}$.

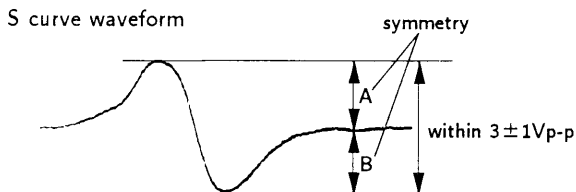

5. After check, remove the lead wire connected in step 2.

Note : • Try to measure several times to make sure that the ratio of A : B or B : A is more than 10 : 7.

- Take sweep time as long as possible and light up the brightness to obtain best waveform.

RF Level Check

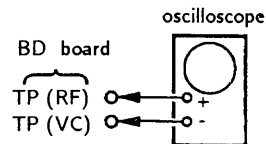

Procedure :

1. Connect oscilloscope to test point TP (RF) on BD board.
2. Turn Power switch on.
3. Put disc (YEDS-18) in and playback.
4. Confirm that oscilloscope waveform is clear and check RF signal level is correct or not.

Note :

Clear RF signal waveform means that the shape “◇” can be clearly distinguished at the center of the waveform.

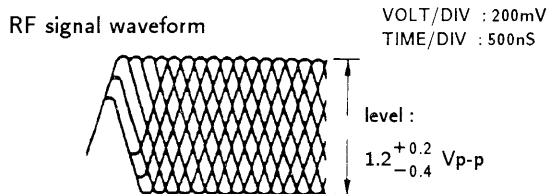

E-F Balance Check

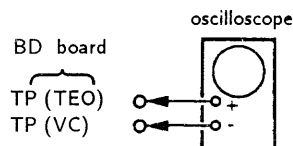

Procedure :

1. Connect test point TP (ADJ) to ground and TP (TES) to TP (VC) with lead wire.
2. Connect oscilloscope to test point TP (TEO) on BD board.
3. Turn Power switch on.
4. Put disc (YEDS-18) in and playback.
5. Confirm that the oscilloscope waveform is symmetrical on the top and bottom in relation to 0V, and check this level.

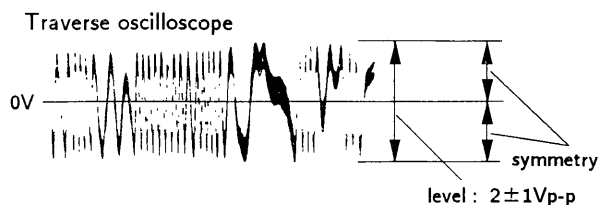

6. Remove the lead wire connected in step 1.

RF PLL Free-run Frequency Check

Procedure :

1. Connect frequency counter to test point (PCK) with lead wire.

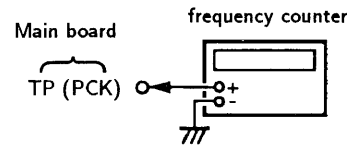

2. Turn Power switch on.
3. Confirm that reading on frequency counter is
4. 3218MHz.

Focus/Tracking Gain

This gain has a margin, so even if it is slightly off. There is no problem.

Therefore, do not perform, this adjustment.

Please note that it should be fixed to mechanical center position when you moved and do not know original position.

Adjustment Locations : [BD board]

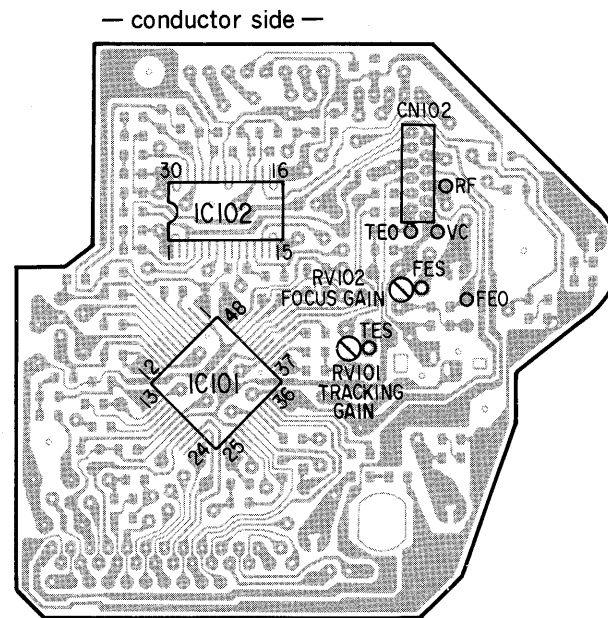

SECTION 4 DIAGRAMS

4-1. CIRCUIT BOARDS LOCATION

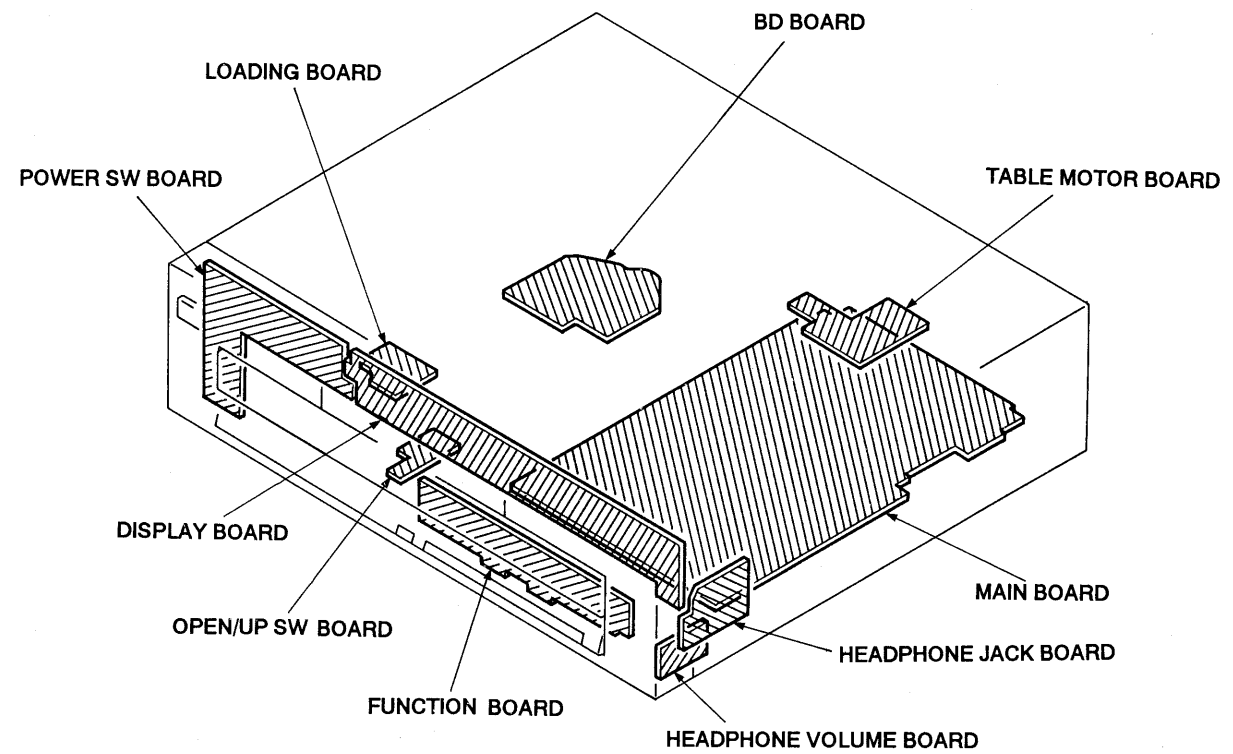

[Main board]

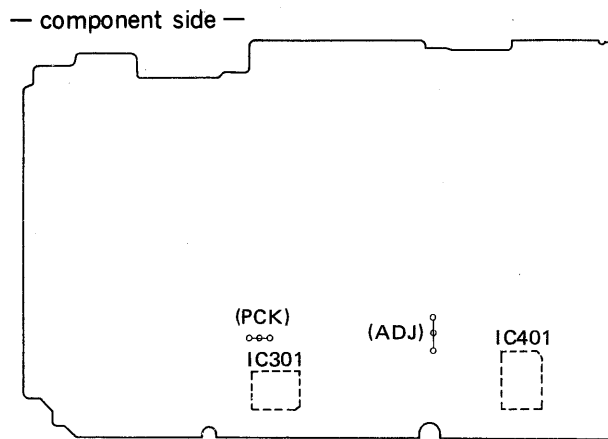

4-2. SEMICONDUCTOR LEAD LAYOUTS

CXA1291P

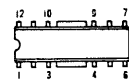

CXD2561M

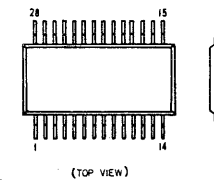

M5F7807L

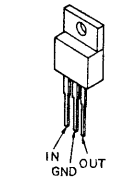

2SA1175-HFE

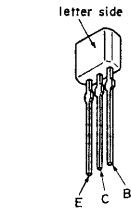

2SC3623-LK DTA144ES DTC144ES

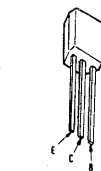

11EQS04 11ES2 1SS120 RD5.6ES-B2 RD6.8ES-B2

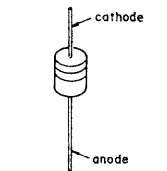

CXD2500AQ CXP50116-213Q

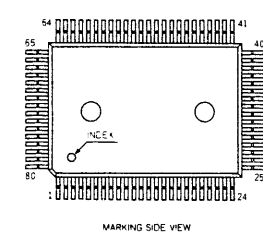

GP1F31T

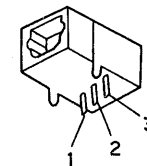

- 1: D OUT
- 2: VDD
- 3: GND

RC4556D RC5532DD

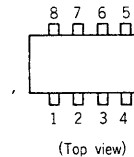

2SB1094-L

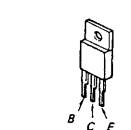

2SD774-34

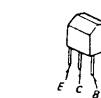

BR4361F

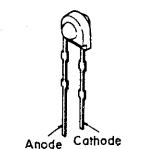

CXD2560M

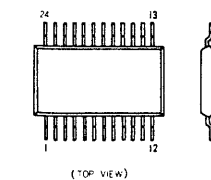

M5293L

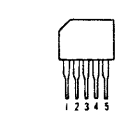

SBX1610-59

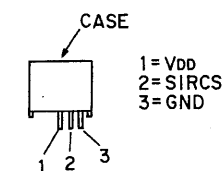

- 1 = VDD
- 2 = SIRCS
- 3 = GND

2SC1815-Y 2SC2878-AB

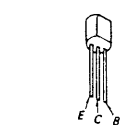

GP-1A521

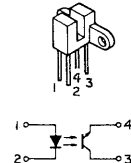

4-3. IC BLOCK DIAGRAMS

IC101 CXA1372Q

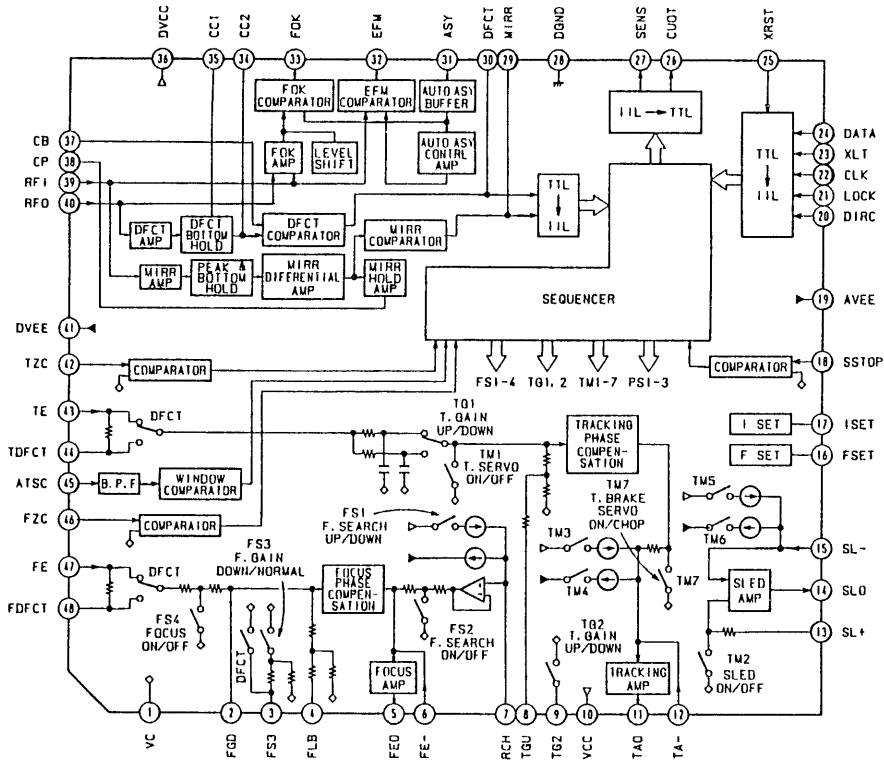

IC102 LA6532M

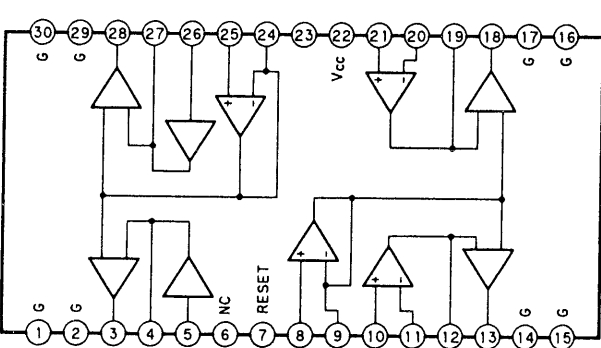

IC201 M5293L

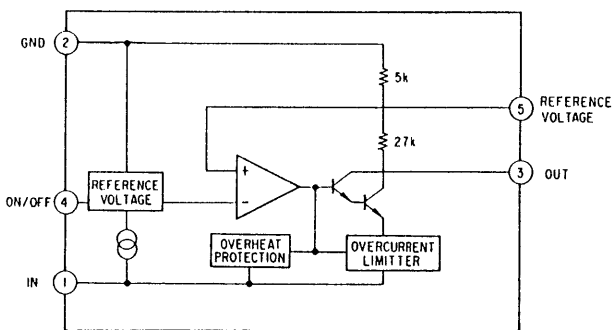

IC202 M5290P-16

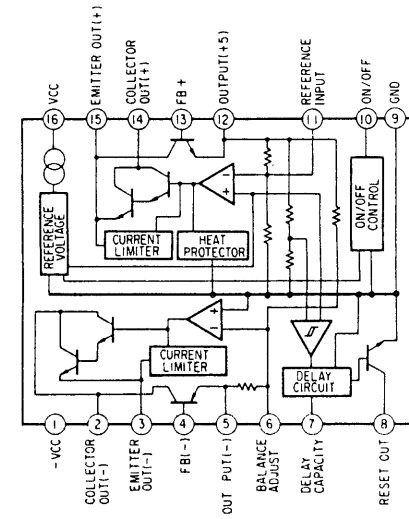

IC301 CXD2500Q

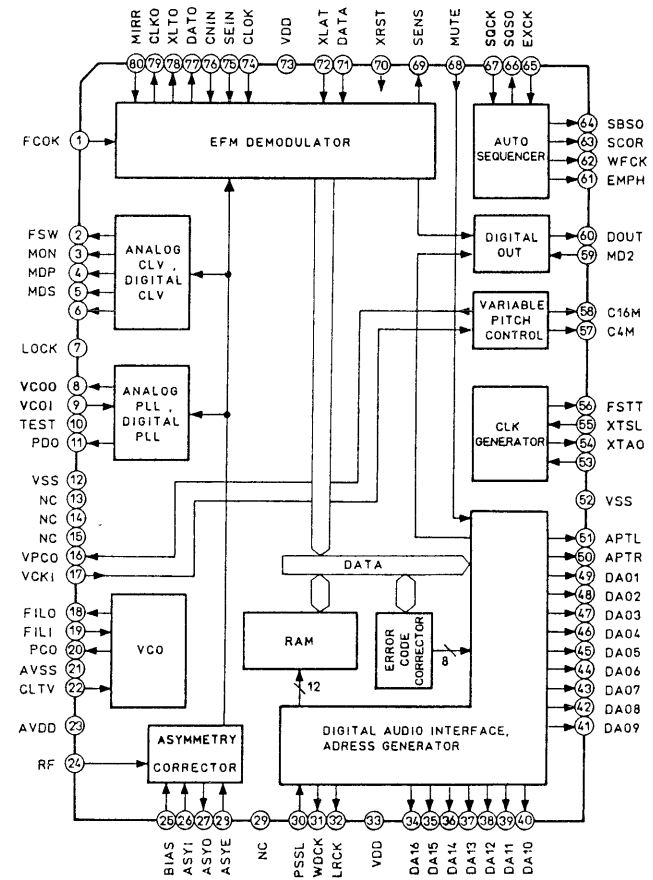

4-4. PRINTED WIRING BOARDS
• Refer to page 9 for Semiconductor Lead Layouts.

• Semiconductor Location

Ref. No.	Location
D201	I-25
D202	I-25
D203	E-24
D204	E-24
D205	E-24
D206	E-24
D208	E-19
D209	E-19
D341	H-21
D351	H-21
D701	B-4 (HP VOL.)
D701	H-30 (TABLE)
IC101	D-29
IC102	C-29
IC201	I-24
IC202	F-23
IC203	F-20
IC204	G-24
IC301	J-21
IC302	I-23
IC303	G-21
IC306	F-18
IC307	F-18
IC308	H-26
IC309	E-17
IC401	I-17
IC402	G-16
IC551	G-14
Q101	E-29
Q201	J-25
Q202	F-23
Q203	E-23
Q204	G-23
Q205	F-23
Q206	F-23
Q209	F-21
Q341	F-16
Q342	F-16
Q343	F-16
Q344	H-21
Q371	G-17
Q372	E-17
Q373	F-17
Q374	F-17
Q375	F-17
Q376	F-17
Q401	I-16

Note:
 ○ : parts extracted from the component side.
 ● : Through hole.
 ◐ : Pattern on the side which is seen.
 ◑ : Pattern of the rear side.

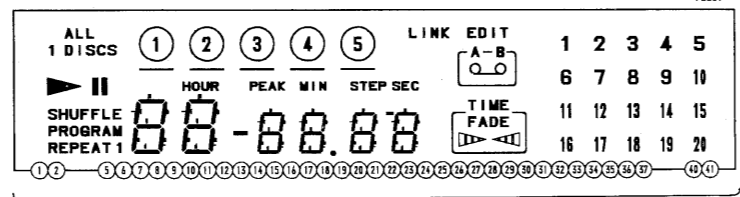
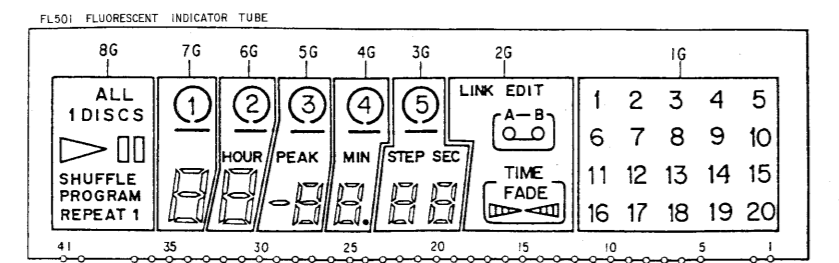
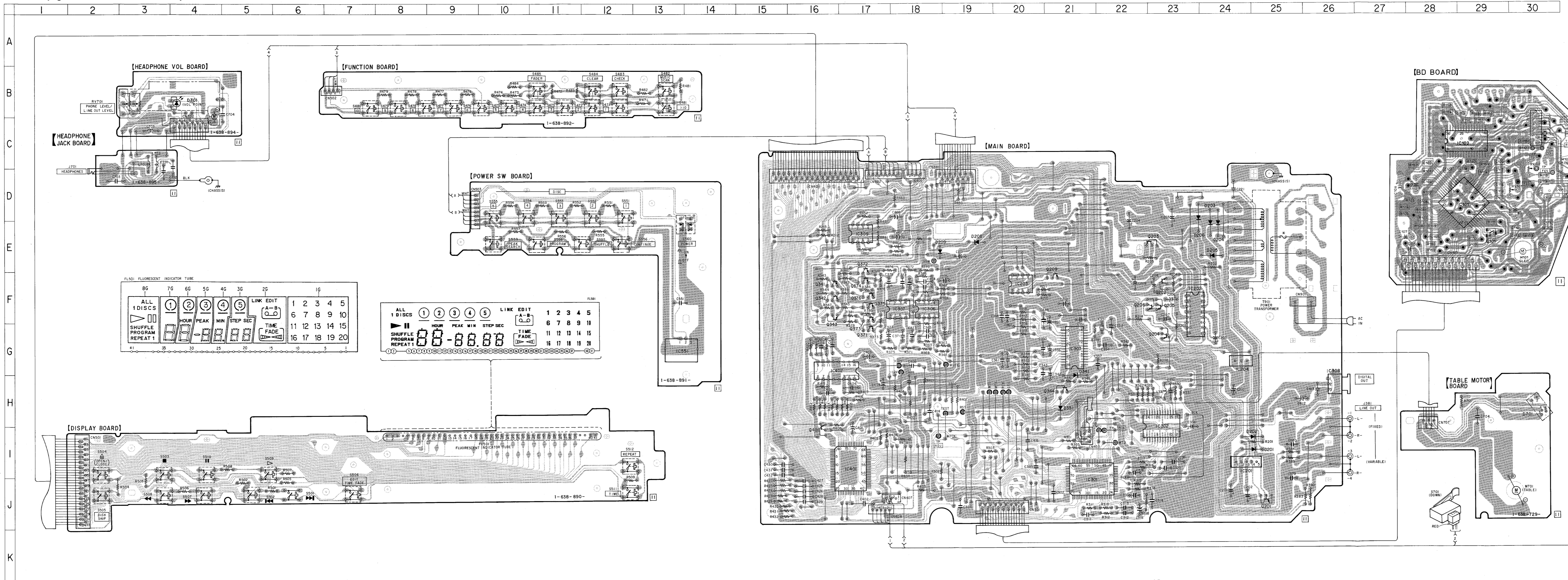

4-5. SCHEMATIC DIAGRAM
 • Refer to page 10 for IC BLOCK Diagrams.

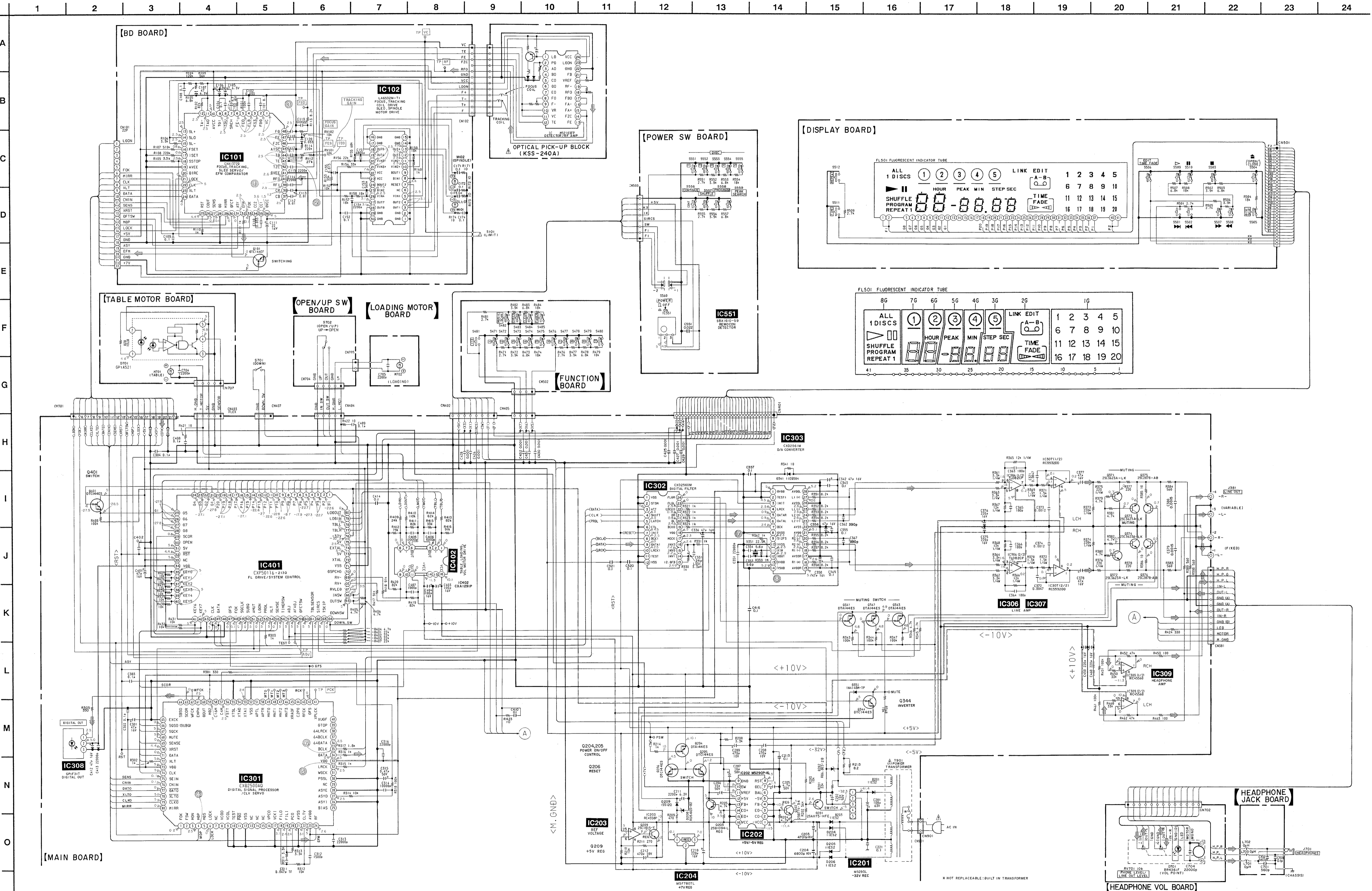

- Note:**
- All capacitors are in μF unless otherwise noted. pF: μF 50WV or less are not indicated except for electrolytics and tantalums.
 - All resistors are in Ω and $\frac{1}{2}W$ or less unless otherwise specified.
- Note:** The components identified by mark Δ or dotted line with mark Δ are critical for safety. Replace only with part number specified.
- Note:** Les composants identifiés par une marque Δ sont critiques pour la sécurité. Ne les remplacer que par une pièce portant le numéro spécifié.
- : B+ Line
 - ◌ : B- Line
 - ◻ : adjustment for repair.
 - Voltage and waveforms are dc with respect to ground under no-signal (detuned) conditions.
 - Voltages are taken with a VOM (Input Impedance 10M Ω) Voltage variations may be noted due to normal production tolerances.
 - Waveforms are taken with an oscilloscope. Voltage variations may be noted due to normal production tolerances.
 - Circled numbers refer to waveforms.
 - Signal path
 - ◻ : CD ◻ : digital out

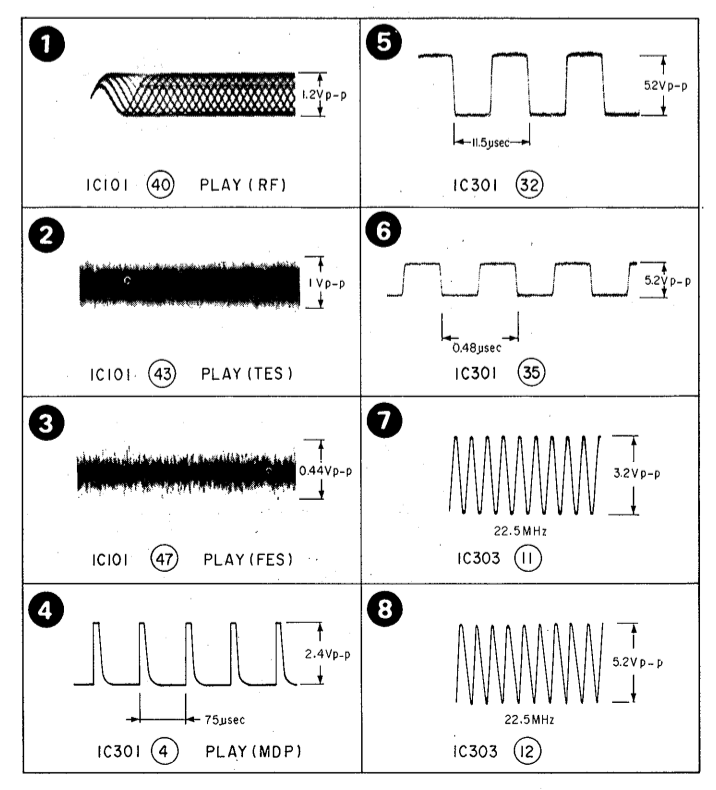

SECTION 5 EXPLODED VIEWS

NOTE:

- -XX, -X mean standardized parts, so they may have some difference from the original one.
- The construction parts of an assembled part are indicated with a collation number in the remark column.
- Items marked " * " are not stocked since they are seldom required for routine service. Some delay should be anticipated when ordering these items.
- The mechanical parts with no reference number in the exploded views are not supplied.
- Hardware (# mark) list is given in the last of this parts list.

The components identified by mark or dotted line with mark are critical for safety. Replace only with part number specified.

Les composants identifiés par une marque sont critiques pour la sécurité. Ne les remplacer que par une pièce portant le numéro spécifié.

5-1. FRONT PANEL AND CASE ASSEMBLIES

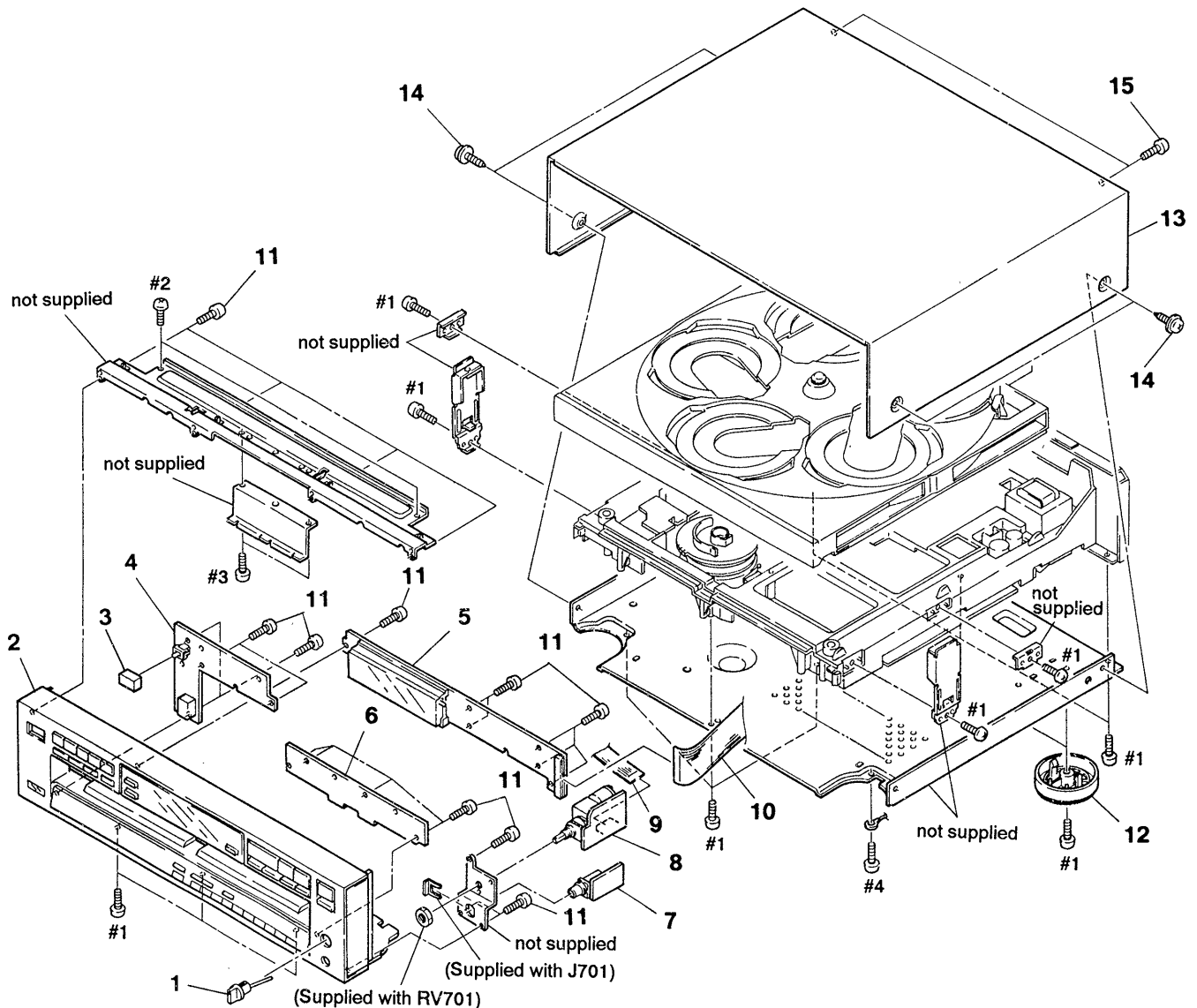

Ref. No.	Part No.	Description	Remark	Ref. No.	Part No.	Description	Remark
1	A-4675-298-A	KNOB (HP) ASSY		9	1-590-834-11	WIRE, FLAT TYPE (13 CORE)	
2	X-4941-483-1	PANEL ASSY, FRONT		10	1-590-835-11	WIRE, FLAT TYPE (34 CORE)	
3	4-922-921-01	BUTTON (POWER)		11	4-928-635-01	SCREW, +BV (2.6X8) TAPPING	
4	* 1-638-891-11	POWER SW BOARD		12	X-4924-464-1	FOOT ASSY	
5	* 1-638-890-11	DISPLAY BOARD		13	* 4-944-153-01	CASE	
6	* 1-638-892-11	FUNCTION BOARD		14	3-704-366-01	SCREW (CASE) (M3X8)	
7	* 1-638-895-11	HEADPHONE JACK BOARD		15	3-703-685-21	SCREW (+BV 3X8)	
8	* 1-638-894-11	HEADPHONE VOLUME BOARD					

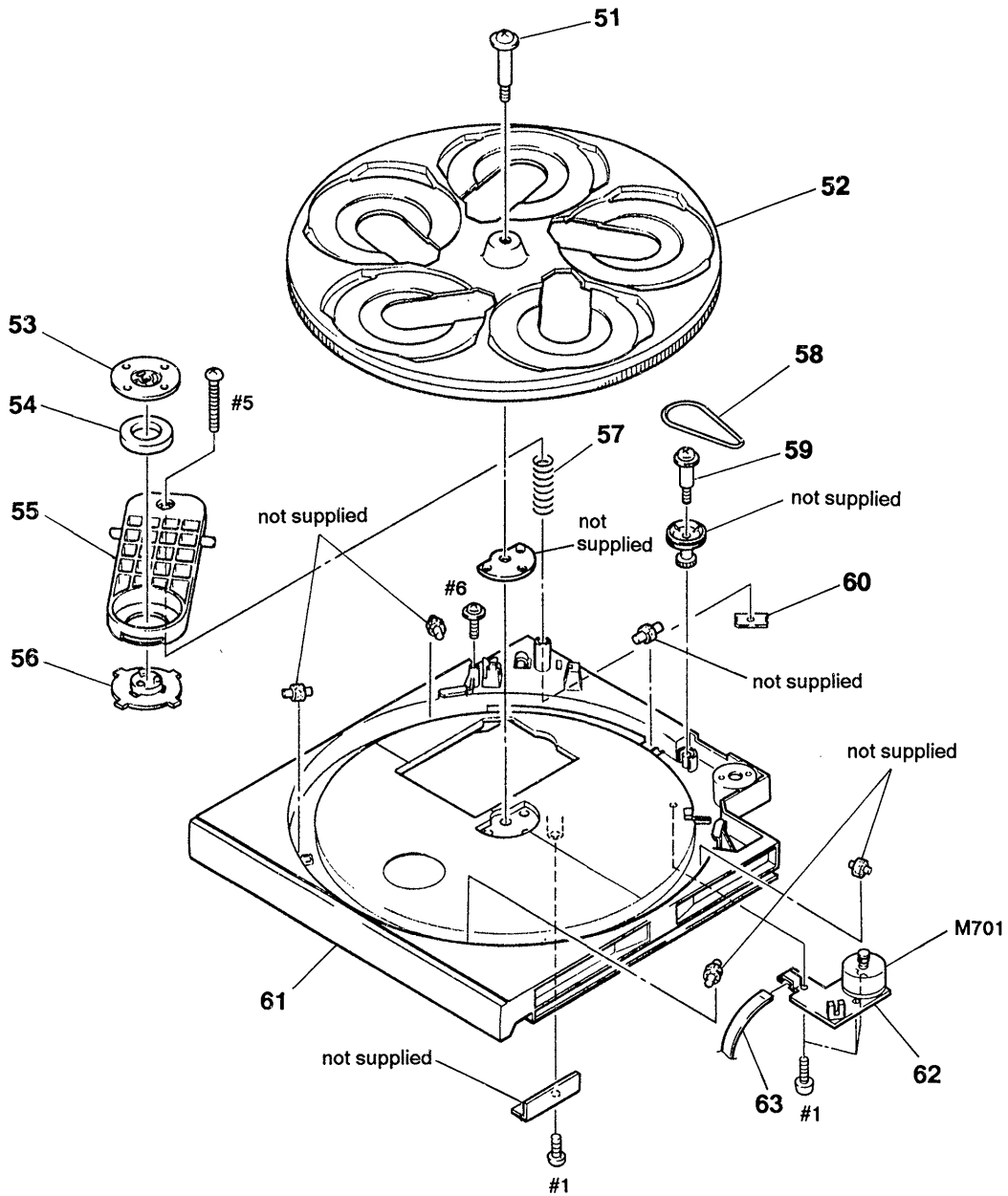

5-2. DISC TRAY ASSEMBLY



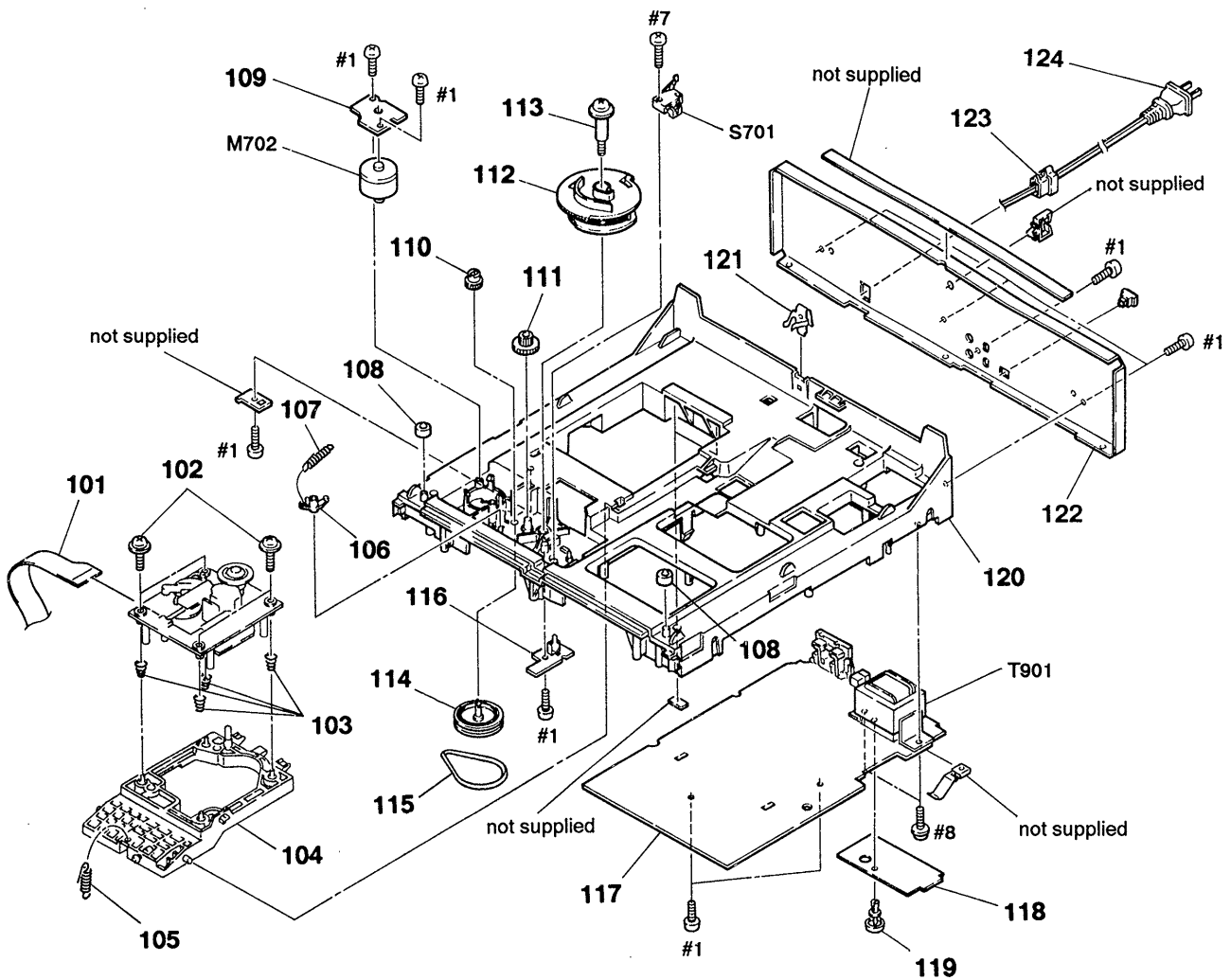

Ref. No.	Part No.	Description	Remark	Ref. No.	Part No.	Description	Remark
51	4-926-384-01	SCREW, STEP		58	4-926-399-01	BELT	
52	* 4-926-383-01	TABLE (B), DISK		59	4-923-597-01	SCREW, STEP	
53	4-921-029-01	YOKE, CHUCKING		60	* 4-926-388-01	BRACKET (ADJUSTMENT)	
54	1-452-340-21	MAGNET		61	4-944-160-01	TABLE (A), DISC	
55	* 4-930-506-02	BRACKET (PRESS PULLEY)		62	* 1-638-729-11	TABLE MOTOR BOARD	
56	4-921-022-01	PULLEY, CHUCKING		63	1-590-849-11	WIRE, FLAT TYPE (5 CORE)	
57	4-926-395-01	SPRING, COMPRESSION		M701	A-4604-585-A	MOTOR ASSY, ROTARY (TABLE)	

5-3. CHASSIS ASSEMBLY



<p>Note: The components identified by mark  or dotted line with mark  are critical for safety. Replace only with part number specified.</p>	<p>Note: Les composants identifiés par une marque  sont critiques pour la sécurité. Ne les remplacer que par une pièce portant le numéro spécifié.</p>
--	--

Ref. No.	Part No.	Description	Remark	Ref. No.	Part No.	Description	Remark
101	1-535-892-11	JUMPER, FILM (WITH TERMINAL)		114	X-4941-529-1	PULLEY ASSY	
102	4-933-134-01	SCREW (+PTPWH M2. 6X6)		115	4-944-490-01	BELT (TIMING)	
103	4-917-541-01	SPRING (B)		116	* 1-638-731-11	OPEN/UP SW BOARD	
104	* 4-934-373-01	BRACKET (BU)		117	* A-4617-818-A	MAIN BOARD, COMPLETE	
105	4-937-911-01	SPRING, TENSION		118	* 4-944-178-01	SHEET (INSULATING)	
106	4-917-519-01	LEVER, SET		119	3-531-576-11	RIVET	
107	4-924-412-01	SPRING (B), TENSION		120	* 4-943-997-01	CHASSIS	
108	* 4-934-382-01	CUSHION		121	* 4-943-996-01	SPRING, LEAF	
109	* 1-638-730-11	LOADING MOTOR BOARD		122	* 4-943-680-11	PANEL, BACK (Canadian)	
110	4-934-375-01	GEAR (LOADING B)		122	* 4-943-680-01	PANEL, BACK (US)	
111	4-934-381-01	GEAR (LOADING C)		123	* 3-703-244-00	BUSHING (2194), CORD	
112	4-934-391-01	GEAR (LOADING A)		124	 1-590-836-11	CORD, POWER	
113	4-926-317-01	SCREW, STEP		M702	A-4604-834-A	MOTOR ASSY, LOADING	
				S701	1-572-713-11	SWITCH, PUSH (WITH CONNECTOR) (DOWN)	
				T901	 1-449-954-11	TRANSFORMER, POWER	

5-4. OPTICAL PICK-UP BLOCK ASSEMBLY
(BU-5BD3)

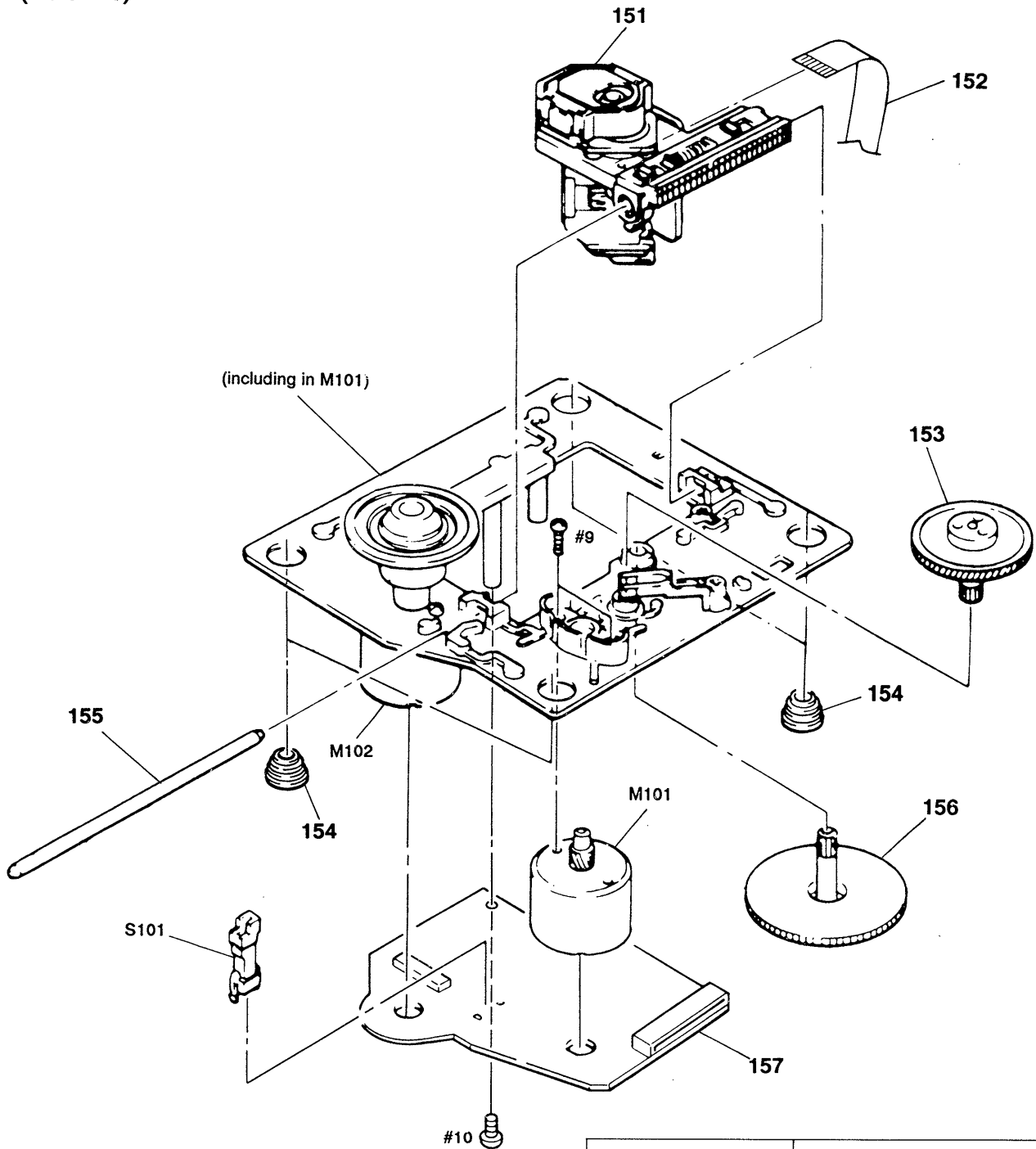

<p>Note: The components identified by mark \triangle or dotted line with mark \triangle are critical for safety. Replace only with part number specified.</p>	<p>Note: Les composants identifiés par une marque \triangle sont critiques pour la sécurité. Ne les remplacer que par une pièce portant le numéro spécifié.</p>
--	---

Ref. No.	Part No.	Description	Remark
151	\triangle 8-848-144-11	DEVICE, OPTICAL KSS-240A	
152	1-575-001-11	WIRE, FLAT TYPE (12 CORE)	
153	4-917-567-01	GEAR (M)	
154	4-933-126-01	INSULATOR (A)	
155	4-917-565-01	SHAFT, SLED	

Ref. No.	Part No.	Description	Remark
156	4-917-564-01	GEAR (P), FLATNESS	
157	* A-4617-371-A	BD BOARD, COMPLETE	
M101	X-4917-504-1	MOTOR ASSY (SLED)	
M102	X-4917-523-3	MOTOR ASSY (SPINDLE)	
S101	1-572-085-11	SWITCH, LEAF (LIMIT IN)	

SECTION 6 ELECTRICAL PARTS LIST

BD

NOTE:

The components identified by mark or dotted line with mark are critical for safety. Replace only with part number specified.

Les composants identifiés par une marque sont critiques pour la sécurité. Ne les remplacer que par une pièce portant le numéro spécifié.

When indicating parts by reference number, please include the board name.

- Due to standardization, replacements in the parts list may be different from the parts specified in the diagrams or the components used on the set.
- -XX, -X mean standardized parts, so they may have some difference from the original one.
- **RESISTORS**
All resistors are in ohms
METAL: Metal-film resistor
METAL OXIDE: Metal Oxide-film resistor
F: nonflammable
- Items marked "*" are not stocked since they are seldom required for routine service. Some delay should be anticipated when ordering these items.
- **SEMICONDUCTORS**
In each case, u: μ , for example:
uA...: μ A..., uPA...: μ PA...,
uPB...: μ PB..., uPC...: μ PC...,
uPD...: μ PD...
- **CAPACITORS**
uF: μ F
- **COILS**
uH: μ H

Ref. No.	Part No.	Description	Remark	Ref. No.	Part No.	Description	Remark
	* A-4617-371-A	BD BOARD, COMPLETE *****				< CONNECTOR >	
		< CAPACITOR >					
C101	1-163-038-00	CERAMIC CHIP	0.1uF 25V				
C102	1-163-989-11	CERAMIC CHIP	0.033uF 10% 25V				
C103	1-126-163-11	ELECT	4.7uF 20% 50V				
C104	1-163-038-00	CERAMIC CHIP	0.1uF 25V				
C105	1-126-154-11	ELECT	47uF 20% 6.3V				
C106	1-126-154-11	ELECT	47uF 20% 6.3V				
C107	1-126-154-11	ELECT	47uF 20% 6.3V				
C108	1-163-038-00	CERAMIC CHIP	0.1uF 25V				
C109	1-163-038-00	CERAMIC CHIP	0.1uF 25V				
C110	1-163-989-11	CERAMIC CHIP	0.033uF 10% 25V				
C111	1-131-367-00	TANTALUM	22uF 10% 20V				
C112	1-164-232-11	CERAMIC CHIP	0.01uF 50V				
C113	1-164-232-11	CERAMIC CHIP	0.01uF 50V				
C114	1-164-161-11	CERAMIC CHIP	0.0022uF 10% 100V				
C115	1-164-161-11	CERAMIC CHIP	0.0022uF 10% 100V				
C117	1-163-038-00	CERAMIC CHIP	0.1uF 25V				
C118	1-163-038-00	CERAMIC CHIP	0.1uF 25V				
C119	1-164-161-11	CERAMIC CHIP	0.0022uF 10% 100V				
C120	1-163-989-11	CERAMIC CHIP	0.033uF 10% 25V				
C151	1-163-019-00	CERAMIC CHIP	0.0068uF 10% 50V				
C152	1-163-038-00	CERAMIC CHIP	0.1uF 25V				
C153	1-163-006-11	CERAMIC CHIP	560PF 10% 50V				
C154	1-164-161-11	CERAMIC CHIP	0.0022uF 10% 100V				
C155	1-163-023-00	CERAMIC CHIP	0.015uF 5% 50V				
C171	1-163-038-00	CERAMIC CHIP	0.1uF 25V				
C172	1-163-038-00	CERAMIC CHIP	0.1uF 25V				
C173	1-163-038-00	CERAMIC CHIP	0.1uF 25V				
C174	1-163-038-00	CERAMIC CHIP	0.1uF 25V				
						< IC >	
				CN101	1-568-796-11	SOCKET, CONNECTOR 22P	
				CN102	1-568-795-11	SOCKET, CONNECTOR 12P	
				IC101	8-752-050-82	IC CXA1372Q	
				IC102	8-759-822-36	IC LA6532M	
						< JACK >	
				J101	1-216-295-00	METAL CHIP 0 5% 1/10W	
				J102	1-216-295-00	METAL CHIP 0 5% 1/10W	
						< TRANSISTOR >	
				Q101	8-729-901-01	TRANSISTOR DTC144EK	
						< RESISTOR >	
				R101	1-216-097-00	METAL CHIP 100K 5% 1/10W	
				R102	1-216-095-00	METAL CHIP 82K 5% 1/10W	
				R103	1-216-091-00	METAL CHIP 56K 5% 1/10W	
				R104	1-216-099-00	METAL CHIP 120K 5% 1/10W	
				R105	1-216-069-00	METAL CHIP 6.8K 5% 1/10W	
				R106	1-216-061-00	METAL CHIP 3.3K 5% 1/10W	
				R107	1-216-114-00	METAL GLAZE 510K 5% 1/10W	
				R108	1-216-105-00	METAL CHIP 220K 5% 1/10W	
				R109	1-216-061-00	METAL CHIP 3.3K 5% 1/10W	
				R110	1-216-049-00	METAL CHIP 1K 5% 1/10W	
				R111	1-216-049-00	METAL CHIP 1K 5% 1/10W	
				R112	1-216-083-00	METAL CHIP 27K 5% 1/10W	
				R113	1-216-071-00	METAL CHIP 8.2K 5% 1/10W	
				R114	1-216-105-00	METAL CHIP 220K 5% 1/10W	
				R152	1-216-073-00	METAL CHIP 10K 5% 1/10W	

BD	HEADPHONE VOLUME	HEADPHONE JACK	MAIN
----	------------------	----------------	------

DISPLAY	POWER SW	FUNCTION
---------	----------	----------

Ref. No.	Part No.	Description	Remark	Ref. No.	Part No.	Description	Remark
R153	1-216-085-00	METAL CHIP	33K 5% 1/10W			< VARIABLE RESISTOR >	
R154	1-216-085-00	METAL CHIP	33K 5% 1/10W				
R155	1-216-093-00	METAL CHIP	68K 5% 1/10W				
R156	1-216-081-00	METAL CHIP	22K 5% 1/10W				
R157	1-216-079-00	METAL CHIP	18K 5% 1/10W				
R158	1-216-079-00	METAL CHIP	18K 5% 1/10W				
R159	1-216-079-00	METAL CHIP	18K 5% 1/10W				
R160	1-216-049-00	METAL CHIP	1K 5% 1/10W				
R171	1-216-001-00	METAL CHIP	10 5% 1/10W				
R172	1-216-001-00	METAL CHIP	10 5% 1/10W				
R173	1-216-001-00	METAL CHIP	10 5% 1/10W				
R174	1-216-001-00	METAL CHIP	10 5% 1/10W				
		< VARIABLE RESISTOR >					
RV101	1-238-016-11	RES. ADJ. CARBON 10K					
RV102	1-238-016-11	RES. ADJ. CARBON 10K					
		< SWITCH >					
S101	1-572-085-11	SWITCH, LEAF (LIMIT)					
		< CAPACITOR >					
C701	1-162-291-31	CERAMIC	560PF 10% 50V				
C702	1-162-291-31	CERAMIC	560PF 10% 50V				
C703	1-164-159-11	CERAMIC	0.1uF 50V				
C704	1-161-494-00	CERAMIC	0.022uF 25V				
		< CONNECTOR >					
CN702	* 1-5468-832-11	SOCKET, CONNECTOR 13P					
		< DIODE >					
D701	8-719-970-49	DIODE BR4361F (VOL POINT)					
		< JACK >					
J701	1-568-519-21	JACK, LARGE TYPE (HEADPHONES)					
		< COIL >					
L701	1-412-473-21	INDUCTOR	0uH				
L702	1-412-473-21	INDUCTOR	0uH				
L703	1-412-473-21	INDUCTOR	0uH				
		< VARIABLE RESISTOR >					
RV701	1-238-750-11	RES. VAR. CARBON 10K/10K (PHONE/LINE OUT LEVEL)					
		< CAPACITOR >					
C201	1-124-572-11	ELECT	100uF 20% 63V				
C202	1-126-059-11	ELECT	10uF 20% 50V				
C203	1-126-937-11	ELECT	4700uF 20% 16V				
C204	1-126-017-11	ELECT	6800uF 20% 16V				
C205	1-126-163-11	ELECT	4.7uF 20% 50V				
C206	1-126-059-11	ELECT	10uF 20% 50V				
C207	1-126-059-11	ELECT	10uF 20% 50V				
C208	1-124-997-11	ELECT	470uF 20% 10V				
C209	1-124-997-11	ELECT	470uF 20% 10V				
C210	1-126-024-11	ELECT	220uF 20% 16V				
C211	1-124-893-11	ELECT	2200uF 20% 10V				
C212	1-124-997-11	ELECT	470uF 20% 10V				
C213	1-164-159-11	CERAMIC	0.1uF 50V				
C221	1-164-159-11	CERAMIC	0.1uF 50V				
C301	1-126-022-11	ELECT	47uF 20% 16V				
C302	1-164-159-11	CERAMIC	0.1uF 50V				
C303	1-164-159-11	CERAMIC	0.1uF 50V				
C304	1-164-159-11	CERAMIC	0.1uF 50V				
C311	1-136-161-00	FILM	0.047uF 5% 50V				
C312	1-161-374-11	CERAMIC	0.0015uF 20% 50V				
C313	1-161-494-00	CERAMIC	0.022uF 25V				
C314	1-162-306-11	CERAMIC	0.01uF 20% 16V				
C315	1-126-300-11	ELECT	0.47uF 20% 50V				
C316	1-161-494-00	CERAMIC	0.022uF 25V				
C320	1-164-159-11	CERAMIC	0.1uF 50V				
C321	1-164-159-11	CERAMIC	0.1uF 50V				
C331	1-162-208-31	CERAMIC	24PF 5% 50V				
C336	1-126-022-11	ELECT	47uF 20% 16V				
C342	1-126-022-11	ELECT	47uF 20% 16V				
C343	1-164-159-11	CERAMIC	0.1uF 50V				

MAIN

DISPLAY

POWER SW

FUNCTION

Ref. No.	Part No.	Description		Remark	Ref. No.	Part No.	Description	Remark
C349	1-164-159-11	CERAMIC	0. 1uF	50V			< CONNECTOR >	
C350	1-126-022-11	ELECT	47uF	20% 16V				
C351	1-161-494-00	CERAMIC	0. 022uF	25V				
C353	1-162-196-31	CERAMIC	5. 6PF	10% 50V	CN301	* 1-573-046-11	SOCKET, CONNECTOR 18P	
C354	1-162-196-31	CERAMIC	5. 6PF	10% 50V	CN381	* 1-568-856-11	SOCKET, CONNECTOR 13P	
					CN401	* 1-573-080-11	SOCKET, CONNECTOR (34P, L TYPE)	
					CN402	* 1-568-946-11	PIN, CONNECTOR 8P	
C355	1-164-159-11	CERAMIC	0. 1uF	50V	CN403	* 1-568-824-11	SOCKET, CONNECTOR 5P	
C356	1-126-022-11	ELECT	47uF	20% 16V				
C357	1-161-772-11	CERAMIC	0. 1uF	10% 25V	CN404	* 1-568-943-11	PIN, CONNECTOR 5P	
C362	1-162-289-31	CERAMIC	390PF	10% 50V	CN405	* 1-568-942-11	PIN, CONNECTOR 4P	
C363	1-162-285-31	CERAMIC	180PF	10% 50V	CN501	* 1-573-080-11	SOCKET, CONNECTOR (34P, L TYPE)	
					CN901	* 1-573-047-11	PIN, CONNECTOR	
C364	1-162-285-31	CERAMIC	180PF	10% 50V			< DIODE >	
C365	1-162-285-31	CERAMIC	180PF	10% 50V	D201	8-719-200-82	DIODE 11ES2	
C366	1-162-285-31	CERAMIC	180PF	10% 50V	D202	8-719-109-97	DIODE RD6. 8ES-2B	
C367	1-162-289-31	CERAMIC	390PF	10% 50V	D203	8-719-200-82	DIODE 11ES2	
C371	1-130-479-00	MYLAR	0. 0047uF	5% 50V	D204	8-719-200-82	DIODE 11ES2	
					D205	8-719-200-82	DIODE 11ES2	
C372	1-130-479-00	MYLAR	0. 0047uF	5% 50V	D206	8-719-200-82	DIODE 11ES2	
C373	1-130-472-00	MYLAR	0. 0012uF	5% 50V	D208	8-719-109-89	DIODE RD5. 6ES-82	
C374	1-130-472-00	MYLAR	0. 0012uF	5% 50V	D209	8-719-912-20	DIODE 1SS120	
C375	1-126-024-11	ELECT	220uF	20% 16V	D341	8-719-210-21	DIODE 11EQS04	
C376	1-126-024-11	ELECT	220uF	20% 16V	D351	8-719-912-20	DIODE 1SS120	
C377	1-126-022-11	ELECT	47uF	20% 16V	FL501	1-519-655-11	FLUORESCENT INDICATOR	
C378	1-126-022-11	ELECT	47uF	20% 16V			< IC >	
C379	1-130-473-00	MYLAR	0. 0015uF	5% 50V	IC201	8-759-633-42	IC M5293L	
C380	1-130-473-00	MYLAR	0. 0015uF	5% 50V	IC202	8-759-630-21	IC M5290P-16	
C401	1-126-022-11	ELECT	47uF	20% 16V	IC203	8-759-945-58	IC RC4558P	
					IC204	8-759-604-86	IC M5F7807L	
C402	1-164-159-11	CERAMIC	0. 1uF	50V	IC301	8-752-337-26	IC CXD2500AO	
C403	1-126-023-11	ELECT	100uF	20% 16V				
C404	1-126-023-11	ELECT	100uF	20% 16V	IC302	8-752-342-65	IC CXD2560M	
C405	1-162-294-31	CERAMIC	0. 001uF	10% 50V	IC303	8-752-343-01	IC CXD2561M	
C406	1-162-294-31	CERAMIC	0. 001uF	10% 50V	IC306	8-759-990-82	IC TL082CP	
					IC307	8-759-982-03	IC RC5532DD	
C407	1-162-294-31	CERAMIC	0. 001uF	10% 50V	IC308	8-759-977-71	IC GP1F31T	
C408	1-164-159-11	CERAMIC	0. 1uF	50V				
C409	1-164-159-11	CERAMIC	0. 1uF	50V	IC309	8-759-981-85	IC RC4556D	
C410	1-164-159-11	CERAMIC	0. 1uF	50V	IC401	8-752-817-42	IC CXP50116-213Q	
C412	1-126-022-11	ELECT	47uF	20% 16V	IC402	8-759-821-32	IC CXA-1291P	
					IC551	8-741-100-48	IC SBX1610-59	
C413	1-161-494-00	CERAMIC	0. 022uF	25V			< JACK >	
C414	1-164-159-11	CERAMIC	0. 1uF	50V	J381	* 1-569-443-11	JACK, PIN 4P (LINE OUT VARIABLE/FIXED)	
C416	1-164-159-11	CERAMIC	0. 1uF	50V			< COIL >	
C425	1-162-294-31	CERAMIC	0. 001uF	10% 50V				
C426	1-162-294-31	CERAMIC	0. 001uF	10% 50V	L331	1-408-403-00	INDUCTOR 3. 3uH	
C427	1-162-294-31	CERAMIC	0. 001uF	10% 50V				
C428	1-162-294-31	CERAMIC	0. 001uF	10% 50V				
C429	1-162-294-31	CERAMIC	0. 001uF	10% 50V				
C430	1-162-294-31	CERAMIC	0. 001uF	10% 50V				
C431	1-162-294-31	CERAMIC	0. 001uF	10% 50V				
C432	1-162-294-31	CERAMIC	0. 001uF	10% 50V				
C450	1-126-024-11	ELECT	220uF	20% 16V				
C460	1-126-024-11	ELECT	220uF	20% 16V				
C551	1-161-494-00	CERAMIC	0. 022uF	25V				

MAIN

DISPLAY

POWER SW

FUNCTION

Ref. No.	Part No.	Description	Remark	Ref. No.	Part No.	Description	Remark
< TRANSISTOR >							
Q201	8-729-119-76	TRANSISTOR 2SA1175-HFE		R322	1-249-417-11	CARBON	1K 5% 1/4W
Q202	8-729-140-96	TRANSISTOR 2SD774-34		R323	1-249-417-11	CARBON	1K 5% 1/4W
Q203	8-729-111-67	TRANSISTOR 2SB1094-L		R324	1-249-417-11	CARBON	1K 5% 1/4W
Q204	8-729-900-65	TRANSISTOR DTA144ES		R330	1-249-417-11	CARBON	1K 5% 1/4W
Q205	8-729-900-89	TRANSISTOR DTC144ES		R331	1-249-417-11	CARBON	1K 5% 1/4W
Q206	8-729-900-89	TRANSISTOR DTC144ES		R341	1-249-393-11	CARBON	10 5% 1/4W
Q209	8-729-281-52	TRANSISTOR 2SC1815-Y		R342	1-249-417-11	CARBON	1K 5% 1/4W
Q341	8-729-900-65	TRANSISTOR DTA144ES		R343	1-249-441-11	CARBON	100K 5% 1/4W
Q342	8-729-900-65	TRANSISTOR DTA144ES		R344	1-249-441-11	CARBON	100K 5% 1/4W
Q343	8-729-900-65	TRANSISTOR DTA144ES		R345	1-249-425-11	CARBON	4.7K 5% 1/4W
Q344	8-729-900-89	TRANSISTOR DTC144ES		R346	1-249-425-11	CARBON	4.7K 5% 1/4W
Q371	8-729-141-30	TRANSISTOR 2SC3623A-LK		R347	1-249-441-11	CARBON	100K 5% 1/4W
Q372	8-729-141-30	TRANSISTOR 2SC3623A-LK		R348	1-249-429-11	CARBON	10K 5% 1/4W
Q373	8-729-141-30	TRANSISTOR 2SC3623A-LK		R351	1-249-428-11	CARBON	8.2K 5% 1/4W
Q374	8-729-141-30	TRANSISTOR 2SC3623A-LK		R352	1-249-428-11	CARBON	8.2K 5% 1/4W
Q375	8-729-231-55	TRANSISTOR 2SC2878-AB		R353	1-249-428-11	CARBON	8.2K 5% 1/4W
Q376	8-729-231-55	TRANSISTOR 2SC2878-AB		R354	1-249-428-11	CARBON	8.2K 5% 1/4W
Q401	8-729-900-89	TRANSISTOR DTC144ES		R355	1-249-428-11	CARBON	8.2K 5% 1/4W
< RESISTOR >							
R201	1-249-435-11	CARBON	33K 5% 1/4W	R358	1-249-428-11	CARBON	8.2K 5% 1/4W
R202	1-249-438-11	CARBON	56K 5% 1/4W	R359	1-247-903-00	CARBON	1M 5% 1/4W
R203	1-249-429-11	CARBON	10K 5% 1/4W	R361	1-249-423-11	CARBON	3.3K 5% 1/4W
R204	1-249-425-11	CARBON	4.7K 5% 1/4W	R362	1-249-423-11	CARBON	3.3K 5% 1/4W
R205	1-249-425-11	CARBON	4.7K 5% 1/4W	R363	1-249-423-11	CARBON	3.3K 5% 1/4W
R208	1-249-423-11	CARBON	3.3K 5% 1/4W	R364	1-249-423-11	CARBON	3.3K 5% 1/4W
R209	1-249-413-11	CARBON	470 5% 1/4W	R365	1-249-430-11	CARBON	12K 5% 1/4W
R210	1-249-429-11	CARBON	10K 5% 1/4W	R366	1-249-430-11	CARBON	12K 5% 1/4W
R211	1-249-410-11	CARBON	270 5% 1/4W	R367	1-249-430-11	CARBON	12K 5% 1/4W
R212	1-249-392-11	CARBON	8.2 5% 1/4W	R368	1-249-430-11	CARBON	12K 5% 1/4W
R213	1-249-392-11	CARBON	8.2 5% 1/4W	R369	1-249-419-11	CARBON	1.5K 5% 1/4W
R214	1-249-417-11	CARBON	1K 5% 1/4W	R370	1-249-419-11	CARBON	1.5K 5% 1/4W
R301	1-249-411-11	CARBON	330 5% 1/4W	R371	1-249-419-11	CARBON	1.5K 5% 1/4W
R302	1-249-417-11	CARBON	1K 5% 1/4W	R372	1-249-419-11	CARBON	1.5K 5% 1/4W
R303	1-249-417-11	CARBON	1K 5% 1/4W	R373	1-247-887-00	CARBON	220K 5% 1/4W
R305	1-249-411-11	CARBON	330 5% 1/4W	R374	1-247-887-00	CARBON	220K 5% 1/4W
R311	1-249-423-11	CARBON	3.3K 5% 1/4W	R375	1-249-409-11	CARBON	220 5% 1/4W
R312	1-249-429-11	CARBON	10K 5% 1/4W	R376	1-249-409-11	CARBON	220 5% 1/4W
R313	1-249-423-11	CARBON	3.3K 5% 1/4W	R377	1-249-409-11	CARBON	220 5% 1/4W
R314	1-249-429-11	CARBON	10K 5% 1/4W	R378	1-249-409-11	CARBON	220 5% 1/4W
R315	1-249-417-11	CARBON	1K 5% 1/4W	R379	1-249-425-11	CARBON	4.7K 5% 1/4W
R316	1-249-417-11	CARBON	1K 5% 1/4W	R380	1-249-425-11	CARBON	4.7K 5% 1/4W
R317	1-249-420-11	CARBON	1.8K 5% 1/4W	R381	1-249-425-11	CARBON	4.7K 5% 1/4W
R318	1-249-441-11	CARBON	100K 5% 1/4W	R382	1-249-425-11	CARBON	4.7K 5% 1/4W
R321	1-249-417-11	CARBON	1K 5% 1/4W	R383	1-249-414-11	CARBON	560 5% 1/4W
				R384	1-249-414-11	CARBON	560 5% 1/4W
				R385	1-249-393-11	CARBON	10 5% 1/4W
				R386	1-249-393-11	CARBON	10 5% 1/4W
				R389	1-249-414-11	CARBON	560 5% 1/4W

MAIN

DISPLAY

POWER SW

FUNCTION

Ref. No.	Part No.	Description		Remark	Ref. No.	Part No.	Description		Remark
R390	1-249-414-11	CARBON	560	5% 1/4W	R477	1-249-424-11	CARBON	3.9K	5% 1/4W
R401	1-249-433-11	CARBON	22K	5% 1/4W	R478	1-249-427-11	CARBON	6.8K	5% 1/4W
R402	1-249-433-11	CARBON	22K	5% 1/4W	R479	1-249-432-11	CARBON	18K	5% 1/4W
R403	1-249-433-11	CARBON	22K	5% 1/4W	R481	1-249-422-11	CARBON	2.7K	5% 1/4W
R404	1-249-425-11	CARBON	4.7K	5% 1/4W	R482	1-249-424-11	CARBON	3.9K	5% 1/4W
R405	1-249-425-11	CARBON	4.7K	5% 1/4W					
R406	1-249-425-11	CARBON	4.7K	5% 1/4W	R483	1-249-427-11	CARBON	6.8K	5% 1/4W
R407	1-249-433-11	CARBON	22K	5% 1/4W	R484	1-249-432-11	CARBON	18K	5% 1/4W
R408	1-249-441-11	CARBON	100K	5% 1/4W	R501	1-249-422-11	CARBON	2.7K	5% 1/4W
R409	1-247-864-11	CARBON	24K	5% 1/4W	R502	1-249-424-11	CARBON	3.9K	5% 1/4W
R410	1-247-880-11	CARBON	110K	5% 1/4W	R503	1-249-427-11	CARBON	6.8K	5% 1/4W
R411	1-249-440-11	CARBON	82K	5% 1/4W	R504	1-249-432-11	CARBON	18K	5% 1/4W
R412	1-247-876-11	CARBON	75K	5% 1/4W	R505	1-249-422-11	CARBON	2.7K	5% 1/4W
R413	1-249-440-11	CARBON	82K	5% 1/4W	R506	1-249-424-11	CARBON	3.9K	5% 1/4W
R414	1-247-874-11	CARBON	62K	5% 1/4W	R507	1-249-427-11	CARBON	6.8K	5% 1/4W
R415	1-249-435-11	CARBON	33K	5% 1/4W	R508	1-249-432-11	CARBON	18K	5% 1/4W
R416	1-247-878-00	CARBON	91K	5% 1/4W	R509	1-249-422-11	CARBON	2.7K	5% 1/4W
R417	1-247-878-00	CARBON	91K	5% 1/4W	R551	1-249-422-11	CARBON	2.7K	5% 1/4W
R418	1-247-878-00	CARBON	91K	5% 1/4W	R552	1-249-424-11	CARBON	3.9K	5% 1/4W
R419	1-249-440-11	CARBON	82K	5% 1/4W	R553	1-249-427-11	CARBON	6.8K	5% 1/4W
R420	1-249-440-11	CARBON	82K	5% 1/4W	R554	1-249-432-11	CARBON	18K	5% 1/4W
R421	1-249-393-11	CARBON	10	5% 1/4W	R555	1-249-422-11	CARBON	2.7K	5% 1/4W
R422	1-249-393-11	CARBON	10	5% 1/4W	R556	1-249-424-11	CARBON	3.9K	5% 1/4W
R423	1-249-393-11	CARBON	10	5% 1/4W	R557	1-249-427-11	CARBON	6.8K	5% 1/4W
R424	1-249-411-11	CARBON	330	5% 1/4W					
R425	1-249-429-11	CARBON	10K	5% 1/4W			< SWITCH >		
R426	1-249-429-11	CARBON	10K	5% 1/4W	S471	1-554-303-21	SWITCH, TACTILE (1)		
R427	1-249-429-11	CARBON	10K	5% 1/4W	S472	1-554-303-21	SWITCH, TACTILE (2)		
R428	1-249-429-11	CARBON	10K	5% 1/4W	S473	1-554-303-21	SWITCH, TACTILE (3)		
R429	1-249-429-11	CARBON	10K	5% 1/4W	S474	1-554-303-21	SWITCH, TACTILE (4)		
R430	1-249-429-11	CARBON	10K	5% 1/4W	S475	1-554-303-21	SWITCH, TACTILE (5)		
R431	1-249-429-11	CARBON	10K	5% 1/4W	S476	1-554-303-21	SWITCH, TACTILE (6)		
R432	1-249-429-11	CARBON	10K	5% 1/4W	S477	1-554-303-21	SWITCH, TACTILE (7)		
R450	1-249-435-11	CARBON	33K	5% 1/4W	S478	1-554-303-21	SWITCH, TACTILE (8)		
R451	1-249-441-11	CARBON	100K	5% 1/4W	S479	1-554-303-21	SWITCH, TACTILE (9)		
R452	1-249-437-11	CARBON	47K	5% 1/4W	S480	1-554-303-21	SWITCH, TACTILE (10)		
R453	1-249-405-11	CARBON	100	5% 1/4W	S481	1-554-303-21	SWITCH, TACTILE (>10)		
R460	1-249-435-11	CARBON	33K	5% 1/4W	S482	1-554-303-21	SWITCH, TACTILE (MUSIC SCAN)		
R461	1-249-441-11	CARBON	100K	5% 1/4W	S483	1-554-303-21	SWITCH, TACTILE (CHECK)		
R462	1-249-437-11	CARBON	47K	5% 1/4W	S484	1-554-303-21	SWITCH, TACTILE (CLEAR)		
R463	1-249-405-11	CARBON	100	5% 1/4W	S485	1-554-303-21	SWITCH, TACTILE (FADER)		
R471	1-249-422-11	CARBON	2.7K	5% 1/4W	S501	1-554-303-21	SWITCH, TACTILE (▶▶▶)		
R472	1-249-424-11	CARBON	3.9K	5% 1/4W	S502	1-554-303-21	SWITCH, TACTILE (◀◀◀)		
R473	1-249-427-11	CARBON	6.8K	5% 1/4W	S503	1-554-303-21	SWITCH, TACTILE (■)		
R474	1-249-432-11	CARBON	18K	5% 1/4W	S504	1-554-303-21	SWITCH, TACTILE (OPEN/CLOSE)		
R476	1-249-422-11	CARBON	2.7K	5% 1/4W	S505	1-554-303-21	SWITCH, TACTILE (DISC SKIP)		
					S506	1-554-303-21	SWITCH, TACTILE (EDIT TIME FADE)		
					S507	1-554-303-21	SWITCH, TACTILE (▶▶)		
					S508	1-554-303-21	SWITCH, TACTILE (◀◀)		
					S509	1-554-303-21	SWITCH, TACTILE (▷)		

MAIN DISPLAY POWER SW FUNCTION TABLE MOTOR

LOADING MOTOR OPEN/UP SW

Ref. No.	Part No.	Description	Remark
S510	1-554-303-21	SWITCH, TACTILE (II)	
S511	1-554-303-21	SWITCH, TACTILE (TIME)	
S512	1-554-303-21	SWITCH, TACTILE (REPEAT)	
S551	1-554-303-21	SWITCH, TACTILE (DISC 1)	
S552	1-554-303-21	SWITCH, TACTILE (DISC 2)	
S553	1-554-303-21	SWITCH, TACTILE (DISC 3)	
S554	1-554-303-21	SWITCH, TACTILE (DISC 4)	
S555	1-554-303-21	SWITCH, TACTILE (DISC 5)	
S556	1-554-303-21	SWITCH, TACTILE (CONTINUE)	
S557	1-554-303-21	SWITCH, TACTILE (SHUFFLE)	
S558	1-554-303-21	SWITCH, TACTILE (PROGRAM)	
S559	1-554-303-21	SWITCH, TACTILE (PEAK SEARCH)	
S560	1-572-714-11	SWITCH, PUSH (POWER ON/OFF)	
		< CRYSTAL >	
X351	1-567-965-11	VIBRATOR, CRYSTAL (22.5MHz)	

	* 1-638-729-11	TABLE MOTOR BOARD	

	* 1-638-730-11	LOADING MOTOR BOARD	

	* 1-638-731-11	OPEN/UP SW BOARD	

		< CAPACITOR >	
C704	1-161-375-00	CERAMIC	0.0022uF 20% 50V
C705	1-161-375-00	CERAMIC	0.0022uF 20% 50V
		< CONNECTOR >	
CN705	* 1-566-214-11	PIN, CONNECTOR (PC BOARD)	2P
CN707	* 1-573-044-11	SOCKET, CONNECTOR	
		< DIODE >	
D701	8-719-970-19	DIODE GP1A521	
		< RESISTOR >	
R701	1-249-416-11	CARBON	820 5% 1/4W
		< SWITCH >	
S702	1-571-300-21	SWITCH, ROTARY (OPEN/UP)	

Ref. No.	Part No.	Description	Remark
		MISCELLANEOUS	

9	1-590-834-11	WIRE, FLAT TYPE (13 CORE)	
10	1-590-835-11	WIRE, FLAT TYPE (34 CORE)	
54	1-452-340-21	MAGNET	
63	1-590-849-11	WIRE, FLAT TYPE (5 CORE)	
101	1-535-892-11	JUMPER, FILM (WITH TERMINAL)	
124	△ 1-590-836-11	CORD, POWER	
151	△ 8-848-144-11	DEVICE, OPTICAL KSS-240A	
152	1-575-001-11	WIRE, FLAT TYPE (12 CORE)	
M101	X-4917-523-3	MOTOR ASSY (SPINDLE)	
M102	X-4917-504-1	MOTOR ASSY (SLED)	
M701	A-4604-585-A	MOTOR ASSY, ROTARY (TABLE)	
M702	A-4604-834-A	MOTOR ASSY, LOADING	
S701	1-572-713-11	SWITCH, PUSH (WITH CONNECTOR)	(DOWN)
T901	△ 1-449-954-11	TRANSFORMER, POWER	

		ACCESSORY & PACKING MATERIAL	

		1-465-730-11	REMOTE COMMANDER(RM-D515)(Include ※1)
		1-559-533-11	CORD, CONNECTION
※1	3-707-584-01	COVER, BATTERY	
	3-753-145-22	MANUAL, INSTRUCTION (ENGLISH)	
	3-753-145-31	MANUAL, INSTRUCTION (FRENCH) (Canadian)	
	4-937-945-01	PLATE (TRANSPORT), LOCK	
	* 4-944-109-31	INDIVIDUAL CARTON	
	* 4-944-110-01	CUSHION (FRONT)	
	* 4-944-111-01	CUSHION (REAR)	

		HARDWARE LIST	

# 1	7-685-647-79	SCREW +BVTP 3X10 TYPE2 N-S	
# 2	7-682-548-04	SCREW +BVTT 3X8 (S)	
# 3	7-682-547-04	SCREW +BVTT 3X6 (S)	
# 4	7-685-648-79	SCREW +BVTP 3X12 TYPE2 N-S	
# 5	7-682-554-04	SCREW +B 3X25	
# 6	7-685-648-79	SCREW (M3X12), TAPPING	
# 7	7-685-136-19	SCREW +P 2.6X12 TYPE2 NON-SLIT	
# 8	7-685-647-79	SCREW, TAPPING	
# 9	7-621-255-15	SCREW +P 2X3	
#10	7-685-134-19	SCREW +BTP 2.6X8 TYPE2 N-S	

<p>Note: The components identified by mark △ or dotted line with mark △ are critical for safety. Replace only with part number specified.</p>	<p>Note: Les composants identifiés par une marque △ sont critiques pour la sécurité. Ne les remplacer que par une pièce portant le numéro spécifié.</p>
--	--