

CDP-C5F/C5S/ C57

SERVICE MANUAL

CDP-C5F:
US Model
Canadian Model
AEP Model
E Model

CDP-C5S:
US Model

CDP-C57:
US Model



Photo: CDP-C5F

SPECIFICATIONS

COMPACT DISC PLAYER CDP-C5F

System	Compact disc digital audio system
Laser	Semiconductor laser ($\lambda = 780 \text{ nm}$) Emission duration: continuous
Laser output	Max. 0.4 mW* * This output is the value measured at a distance of about 1.6 mm from the objective lens surface on the Optical Pick-up Block.
Frequency response	2 Hz - 20 kHz ($\pm 0.5 \text{ dB}$)
Signal to noise ratio	More than 95 dB
Dynamic range	More than 93 dB
Harmonic distortion	Less than 0.005% (1 kHz)
Channel separation	More than 90 dB (1 kHz)
Wow and flutter	Below measurable limit
Outputs	LINE OUT (phono jacks) Output level 2 V (at 50 kilohms) Load impedance over 10 kilohms HEADPHONES (stereo phone jack) Output level 0 - 28 mW (variable) (at 32 ohms) Output impedance 220 ohms

General

Power requirements	US, Canadian: 120 V AC, 60 Hz AEP model: 220 V AC (240 V AC, adjustable by authorized Sony personnel), 50/60 Hz E model: 120/220/240 V AC, switchable, 50/60 Hz 120 V AC, 60 Hz
Power consumption	10 W
AC outlet (USA model only)	100 W max. unswitched
Dimensions	Approx. 430 × 106 × 415 mm (w/h/d) (17 × 4 ¹ / ₄ × 16 ³ / ₈ inches) not including projecting parts and controls
Weight	Approx. 7.5 kg (16 lbs 9 oz), net

REMOTE COMMANDER RM-D5

Remote control system	Infrared control
Power requirements	3 V DC with two size AA (R6) batteries
Dimensions	43 × 20 × 175 mm (w/h/d) (1 ³ / ₄ × 7 ⁷ / ₈ × 6 ⁷ / ₈ inches)
Weight	145 g (5 oz) including batteries

Note

This appliance conforms with EEC Directives 76/889 and 82/499 regarding interference suppression.

SAFETY-RELATED COMPONENT WARNING!!

COMPONENTS IDENTIFIED BY SHADING AND MARK  ON THE SCHEMATIC DIAGRAMS AND IN THE PARTS LIST ARE CRITICAL TO SAFE OPERATION. REPLACE THESE COMPONENTS WITH SONY PARTS WHOSE PART NUMBERS APPEAR AS SHOWN IN THIS MANUAL OR IN SUPPLEMENTS PUBLISHED BY SONY.

ATTENTION AU COMPOSANT AYANT RAPPORT À LA SÉCURITÉ!

LES COMPOSANTS IDENTIFIÉS PAR UNE TRAME ET UNE MARQUE  SUR LES DIAGRAMMES SCHEMATIQUES ET LA LISTE DES PIÈCES SONT CRITIQUES POUR LA SÉCURITÉ DE FONCTIONNEMENT. NE REMPLACER CES COMPOSANTS QUE PAR DES PIÈCES SONY DONT LES NUMÉROS SONT DONNÉS DANS CE MANUEL OU DANS LES SUPPLÉMENTS PUBLIÉS PAR SONY.

COMPACT DISC PLAYER SONY®

AUD



使用時は添付資料も参照のこと
Refer to the additional documents.

FEATURES

Compact disc player with 5 disc trays

Plays up to 5 discs continuously with its disc compartment having 5 disc trays (MULTI play).

Direct access to the desired disc

Any disc in the compartment can be played with the DISC SELECT button any time you want (MULTI PLAY).

Various functions

- PROGRAM play function for playing up to 32 selections on any disc in a desired order
- SHUFFLE play function for playing the selections in a random order
- Repeat function for normal, PROGRAM and SHUFFLE play in either SINGLE or MULTI mode

Memory back up

The programmed playback order is retained for approximately 3 days with the power turned off or with the disc compartment being opened. This allows you to confirm the programmed order referring to the disc labels with the compartment open.

CAUTIONS ABOUT DISCTABLE

- * Do not push the disc-table in or pull it out forcibly, since the disc-table does not work without the power switched on.
- * Be careful not to disturb the disc-table in ejecting motion.
- * If something like a wire or a finger is caught by the disc-table, depress the OPEN/CLOSE button as soon as possible, so that the disc-table will move reversely.

CONTENTS

Section	Title	Page
SPECIFICATIONS	1
FEATURES	2
SAFETY CHECK-OUT (US Model)	2
MODEL IDENTIFICATION	3
SECTION 1	OUTLINE	
1-1.	LOCATION AND FUNCTION OF CONTROLS	3
1-2.	AUTO PAUSE	5-2
	NOTES ON HANDLING THE OPTICAL	7
SECTION 2	DISASSEMBLY	8
SECTION 3	ADJUSTMENTS	9-12
SECTION 4	CIRCUIT BOARDS LOCATION	12
SECTION 5	DIAGRAMS	
5-1.	MOUNTING DIAGRAM	13-14
5-2.	SCHEMATIC DIAGRAM	15-16
5-3.	MOUNTING DIAGRAM	17-20
5-4.	SCHEMATIC DIAGRAM	21-25
	IC BLOCK DIAGRAMS	27
	SEMICONDUCTOR LEAD LAYOUTS	29
SECTION 6	EXPLODED VIEWS AND PARTS LIST	30-34
SECTION 7	ELECTRICAL PARTS LIST	35-40
SECTION 8	TROUBLE SHOOTING	40

SAFETY CHECK-OUT (US Model)

After correcting the original service problem, perform the following safety check before releasing the set to the customer:

Check the antenna terminals, metal trim, "metallized" knobs, screws, and all other exposed metal parts for AC leakage. Check leakage as described below.

LEAKAGE TEST

The AC leakage from any exposed metal part to earth ground and from all exposed metal parts to any exposed metal part having a return to chassis, must not exceed 0.5 mA (500 microampers). Leakage current can be measured by any one of three methods.

1. A commercial leakage tester, such as the Simpson 229 or RCA WT-540A. Follow the manufacturers' instructions to use these instruments.
2. A battery-operated AC milliammeter. The Data Precision 245 digital multimeter is suitable for this job.
3. Measuring the voltage drop across a resistor by means of a VOM or battery-operated AC voltmeter. The "limit" indication is 0.75 V, so analog meters must have an accurate low-voltage scale. The Simpson 250 and Sanwa SH-63Trd are examples of a passive VOM that is suitable. Nearly all battery operated digital multimeters that have a 2 V AC range are suitable. (See Fig. A)

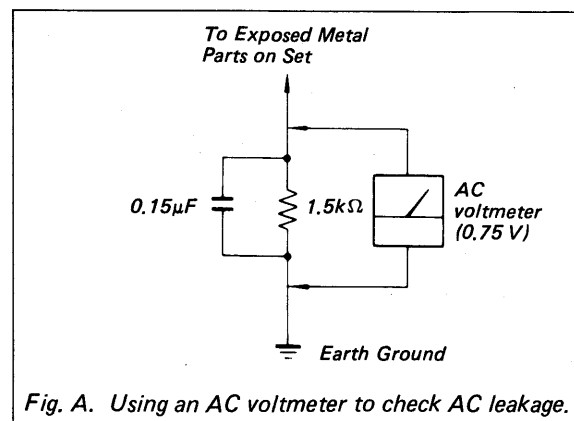
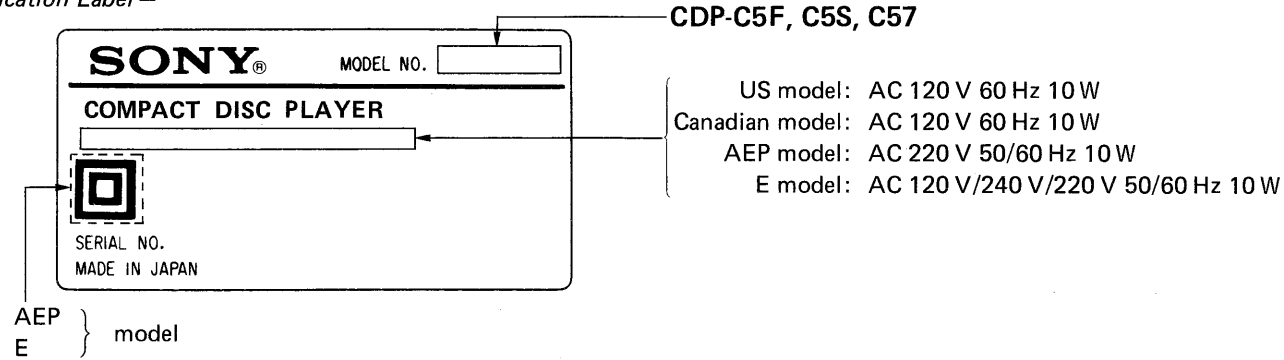

Fig. A. Using an AC voltmeter to check AC leakage.

MODEL IDENTIFICATION

— Specification Label —



**SECTION 1
OUTLINE**

1-1. LOCATION AND FUNCTION OF CONTROLS

FRONT PANEL

DISC SELECT buttons and indicators

Remote sensor

Disc compartment
Contains up to 5 discs.

HEADPHONES jack and LEVEL (headphones level) control

POWER switch

TIMER switch

Mode indicators
 ▶ PLAY: Lights up while playing and during pause.
 || PAUSE: Lights up during pause.
 ■ SHUFFLE: Lights up during SHUFFLE play.
 ■ RMS* (program) indicator: Lights up while programming and during PROGRAM play.

AUTO PAUSE switch

SHUFFLE play button

DISC PLAY MODE buttons

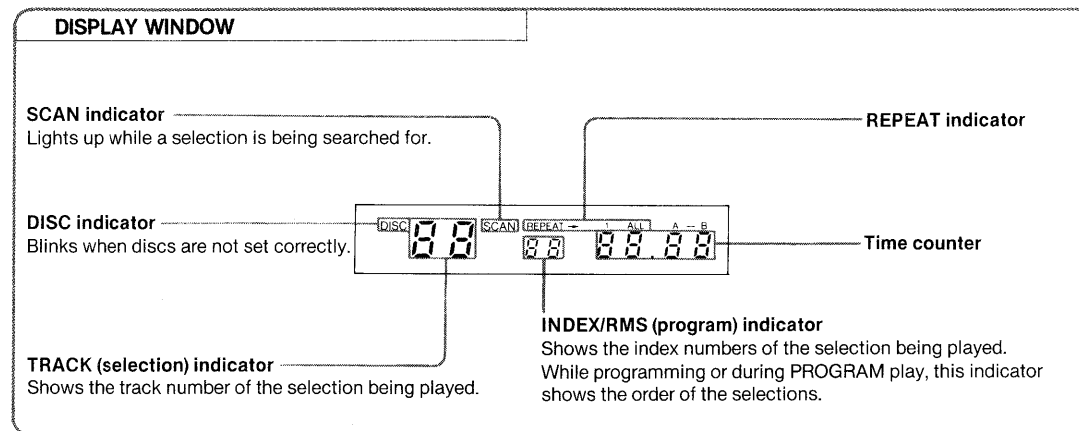

DISC SKIP button

RANDOM MUSIC SENSOR buttons
 PROGRAM button
 CHECK program button
 CLEAR program button

Function buttons
 ▶ (play) button
 || (pause) button
 ◀▶ (AMS **/RMS *) buttons
 ◀▶ (manual search) buttons
 ■ (stop) button

OPEN/CLOSE button

TIME button

REPEAT (repeat play) button

* RMS is an abbreviation of Random Music Sensor.
 ** AMS is an abbreviation of Automatic Music Sensor.

1-2. AUTO PAUSE**DESCRIPTION ON REAR PANEL****LINE OUT (audio output) jacks**

Connect these jacks to the CD or auxiliary input jacks of an amplifier.

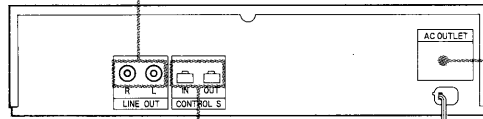
**CONTROL S IN/OUT connectors (4-pin)**

When the CONTROL S IN connector is connected to the CONTROL S OUT connector of an audio equipment with CONTROL S connectors, the remote sensor of the connected equipment can be used to receive the commands emitted from the remote commander of both the CDP-C5F and the connected equipment.

The CONTROL S OUT connector is to be connected to the CONTROL S IN connector of another audio equipment.





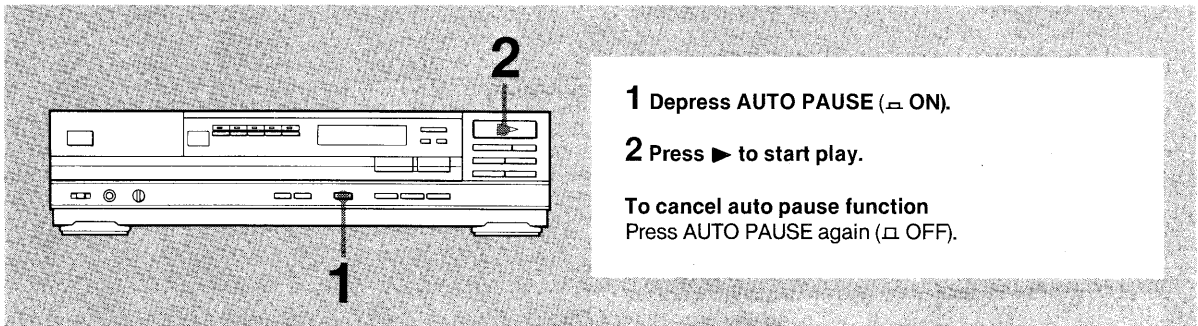

AC outlet (unswitched)
Used to power other audio components whose power consumption is less than 100 watts.

AC power cord

Using the auto pause function, the CD player enters the pause mode automatically each time a selection has been played. This function is useful for recording.

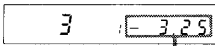

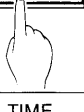
During play, the display shows one of the following types of information.
The display modes can be switched each time the TIME button is pressed.

	Normal play (MULTI, SINGLE)	PROGRAM, SHUFFLE play
During play	1 Track No.  Elapsed playing time of the selection Index No. or program No.	
↓ TIME 	2  Remaining time of the selection	
↓ TIME 	3  Elapsed time of the disc	Returns to 1.
↓ TIME 	4  Remaining time of the disc	
↓ TIME 	Returns to 1.	

The TIME button can also be used while the player is not playing the disc to get the following information.

Before playing (standby)	While choosing a selection	Before performing program play (standby)
0	6 4 5 0 ↑ Playing time of the selection	R 3 0
↓ TIME ↑ while being pressed	↓ TIME ↑ while being pressed	↓ TIME ↑ while being pressed
1 3 5 3 2 9 ↑ ↑ Total number of selections on the disc Total playing time of the disc	6 3 0 1 5 ↑ Total time counted from the beginning of the disc to the end of the selection being chosen	3 4 2 3 9 ↑ Total playing time of the program*
		* This information appears when a track number of 20 or less are programmed. If a track number of 21 or higher is programmed, the display shows "----".

To get information on another disc in MULTI play mode
Press the DISC SELECT button corresponding to the disc to be checked so that the DISC SELECT indicator of the disc lights in green. Use then the TIME button.

- Notes**
- Information on the time can be displayed only when the disc compartment is closed.
 - If you have programmed selections with the disc compartment open, information on the time is displayed only after the compartment is closed and the player has read the contents of the disc(s).
 - In the MULTI play mode, the disc compartment may rotate when the TIME button is activated so that the player can read the disc contents.

NOTES ON HANDLING THE OPTICAL PICK-UP BLOCK OR BASE UNIT

The laser diode in the optical pick-up block may suffer electrostatic breakdown because of the potential difference generated by the charged electrostatic load, etc. on clothing and the human body. During repair, pay attention to electrostatic breakdown and also use the procedure in the printed matter which is included in the repair parts. The flexible board is easily damaged and should be handled with care.

SECTION 2 DISASSEMBLY

Note: Follow the disassembly procedure in the numerical order given.

FRONT PANEL

A. When disc table opens automatically by pressing OPEN/CLOSE button;

- ① Remove top cover.
- ② Press POWER switch to turn the power on.
- ③ Press OPEN/CLOSE button to open disc table.

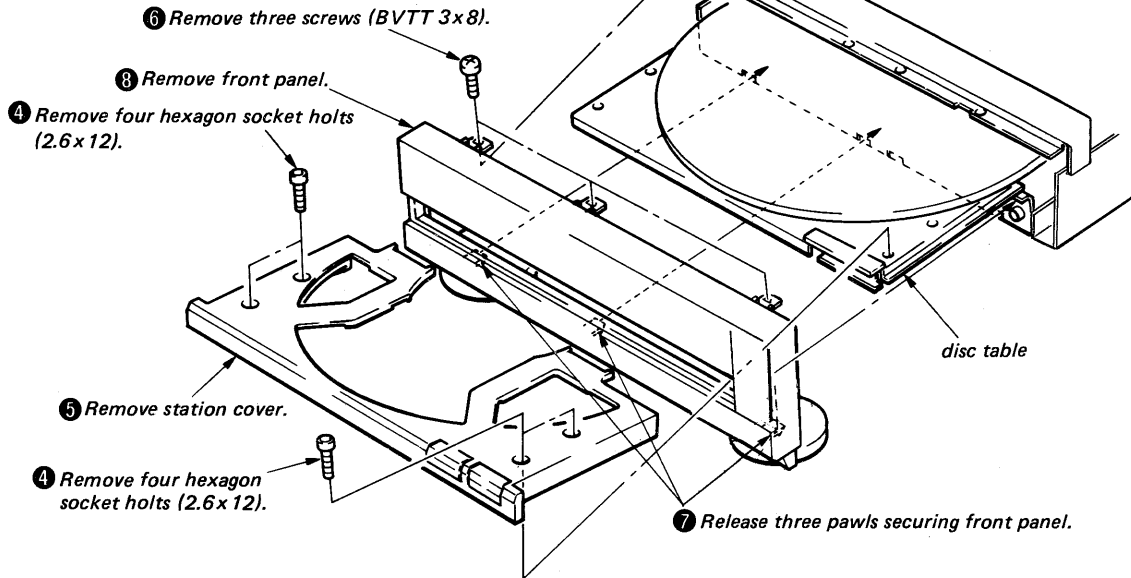

B. When disc table does not open even if OPEN/CLOSE button is pressed;

- ① Remove top cover.
- ⑤ Pull disc table by hand and open.
- ⑥ Perform steps A- 4. to A- 8.

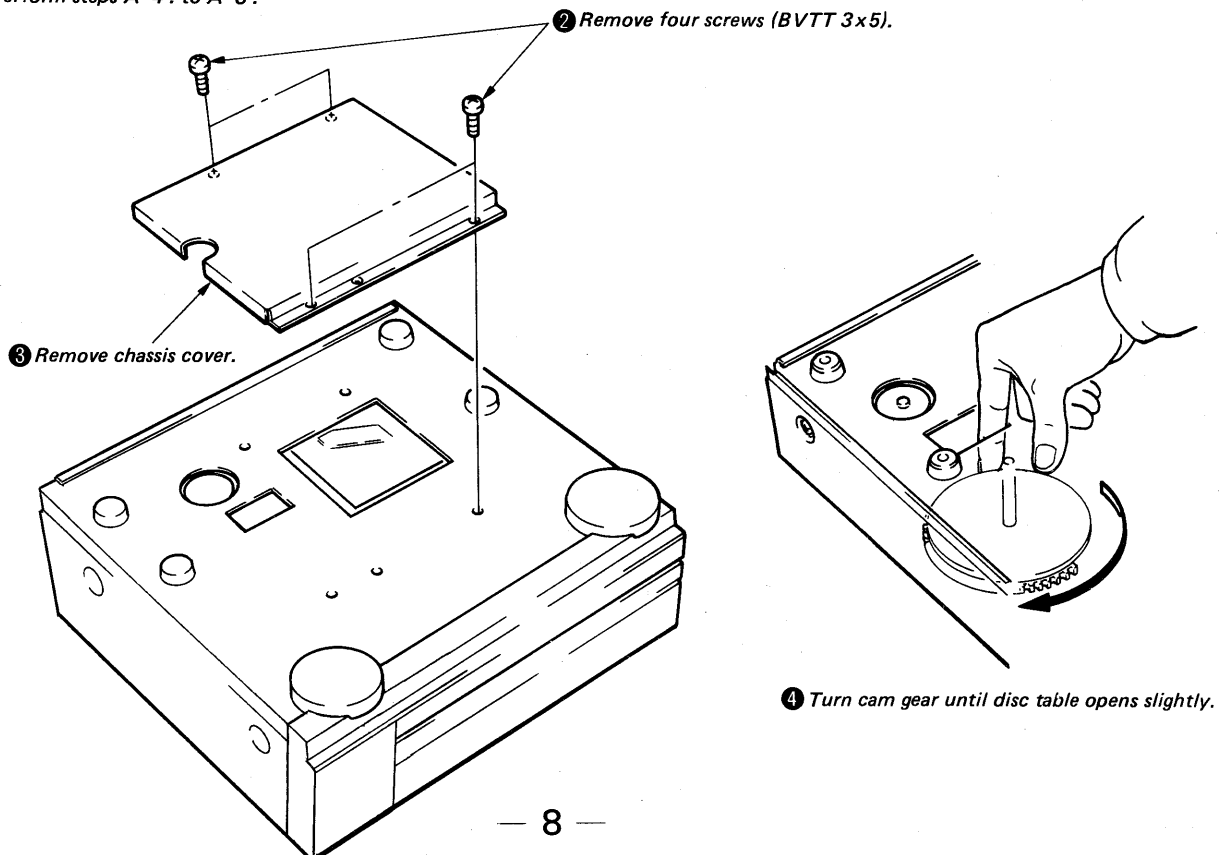

**SECTION 3
ADJUSTMENTS**

SETTING (FOR ADJUSTMENT)

1. Turn RV506 and RV507 clockwise fully.
2. Switch on the power and open the disc table pressing OPEN/CLOSE button.
3. Switch off the power.
4. Put the test disc YEDS-18 (3-702-101-01) into the disc position.
5. Ground the test point CHECK MODE 1 on MAIN BOARD.
6. Switch on the power again, and ready to adjust.

RF PLL Frequency Adjustment/Lock Frequency Check

Procedure:

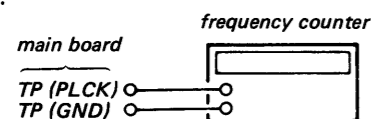

1. Ground test point TP (ASY).
2. Connect the frequency counter to the test points TP (PLCK) and TP (GND).
3. Turn POWER switch on.
4. Adjust RV505 so that the reading on the frequency counter is 4.3218 MHz \pm 30 kHz. (RF PLL frequency adjustment)
5. Remove the grounding wire from TP (ASY).
6. Put the disc (YEDS-18) in and press \triangleright button.
7. Confirm that the reading on the frequency counter is locked at 4.3218 MHz.

Adjustment Location: main board

[RF BOARD] [MAIN BOARD]

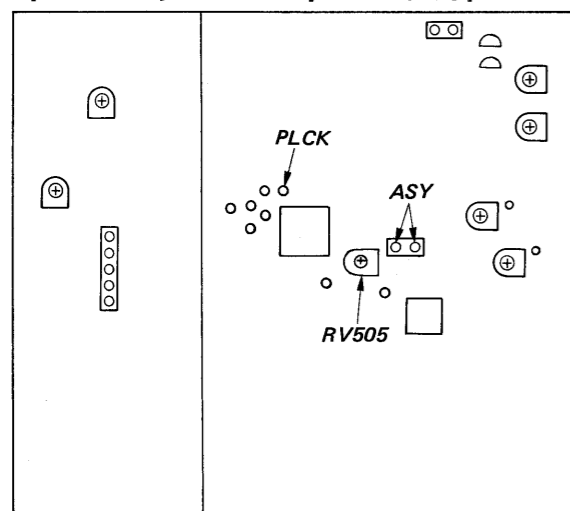

[COMPONENT SIDE]

Focus Bias Adjustment

This adjustment should be made after replacing the Optical Pick-up Block.

Procedure:

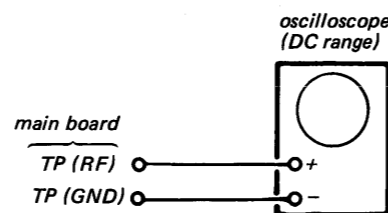

1. Connect oscilloscope to the test points TP (RF) and TP (GND).
2. Turn POWER switch on.
3. Put the disc (YEDS-1) in and press \triangleright button.
4. Adjust RV502 for an optimum waveform eye pattern. Optimum eye pattern means that shape "◇" can be clearly distinguished at the center of the waveform.

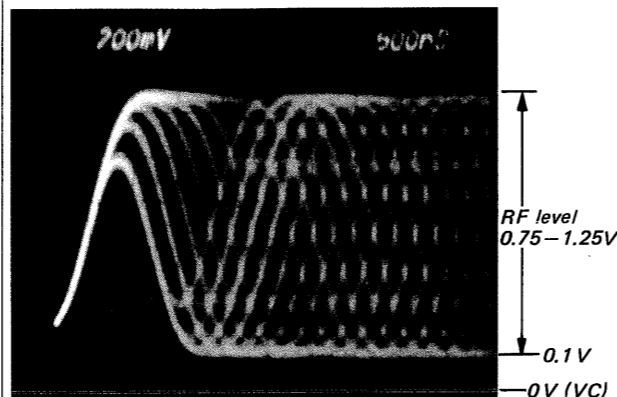

Adjustment Location: RF board

[RF BOARD] [MAIN BOARD]

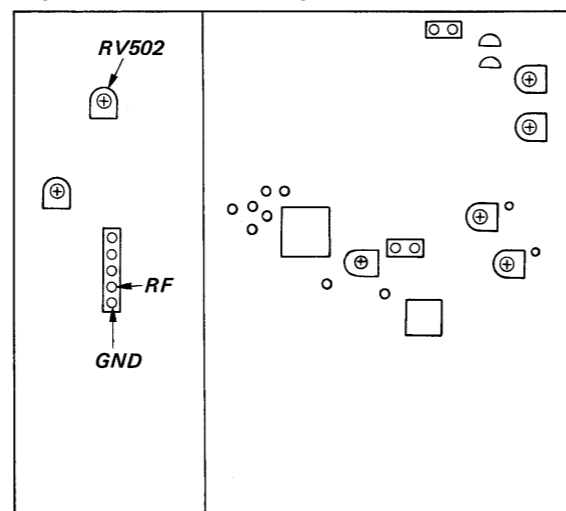

[COMPONENT SIDE]

E-F Balance Adjustment

This adjustment should be made after replacing the Optical Pick-up Block.

Procedure:

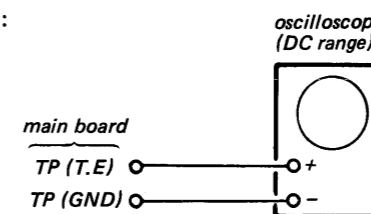

1. Connect the oscilloscope to the test points TP (T.E) and TP (GND).
2. Ground TP (ASY) to set an adjustment mode.
3. Turn POWER switch on.
4. Put the disc (YEDS-18) in and press \triangleright button.
5. Adjust RV501 so that the traverse waveform is symmetrical above and below.
6. After adjustment, cancel the adjustment mode.

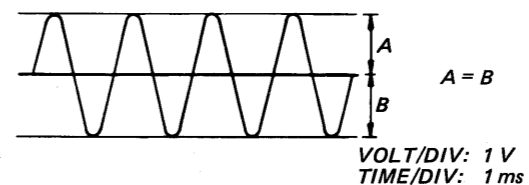

Adjustment Location: main board, RF board

[RF BOARD] [MAIN BOARD]

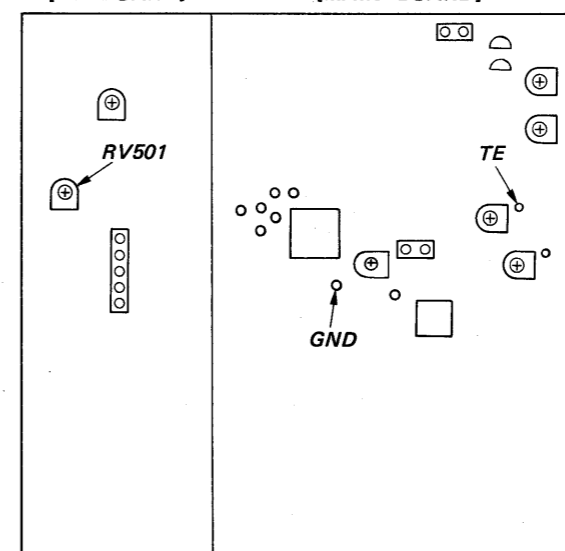

[COMPONENT SIDE]

SENSITIVITY ADJUSTMENT OF DISC SENSOR & DISC COUNT SENSOR

1. Open the disc table.
2. Press SINGLE button of DISC PLAY MODE buttons.
3. Connect the oscilloscope to the collector of Q515.
4. Check if the voltage at the collector of Q515 (disc count sensor amp) is more than 2.5 V, turning the disc table with DISC SKIP BUTTON.
5. If the specification above is not met, adjust RV506 so that the voltage will satisfy the specification level.
6. As to Q516, take the same procedures as Q515. To adjust the voltage, turn RV507.

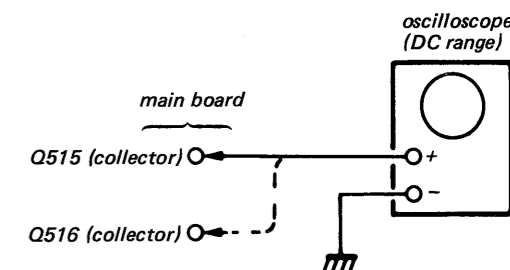

•SPECIFICATION
2.5 V more than

Adjustment Location: main board

[RF BOARD] [MAIN BOARD] Q516

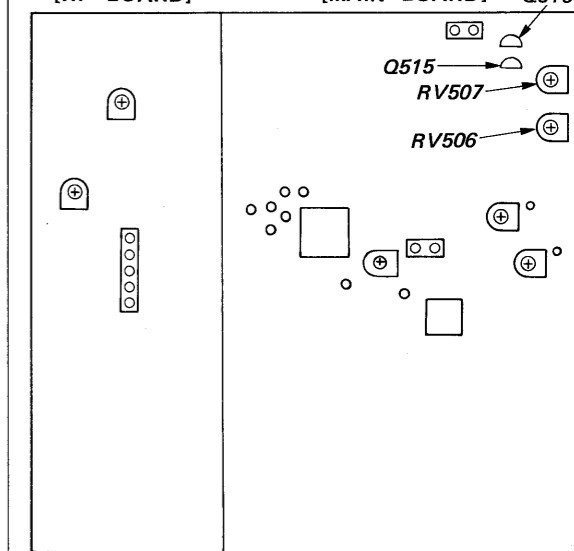

[COMPONENT SIDE]

5-1. MOUNTING DIAGRAM

• See page 28 for semiconductor locations.

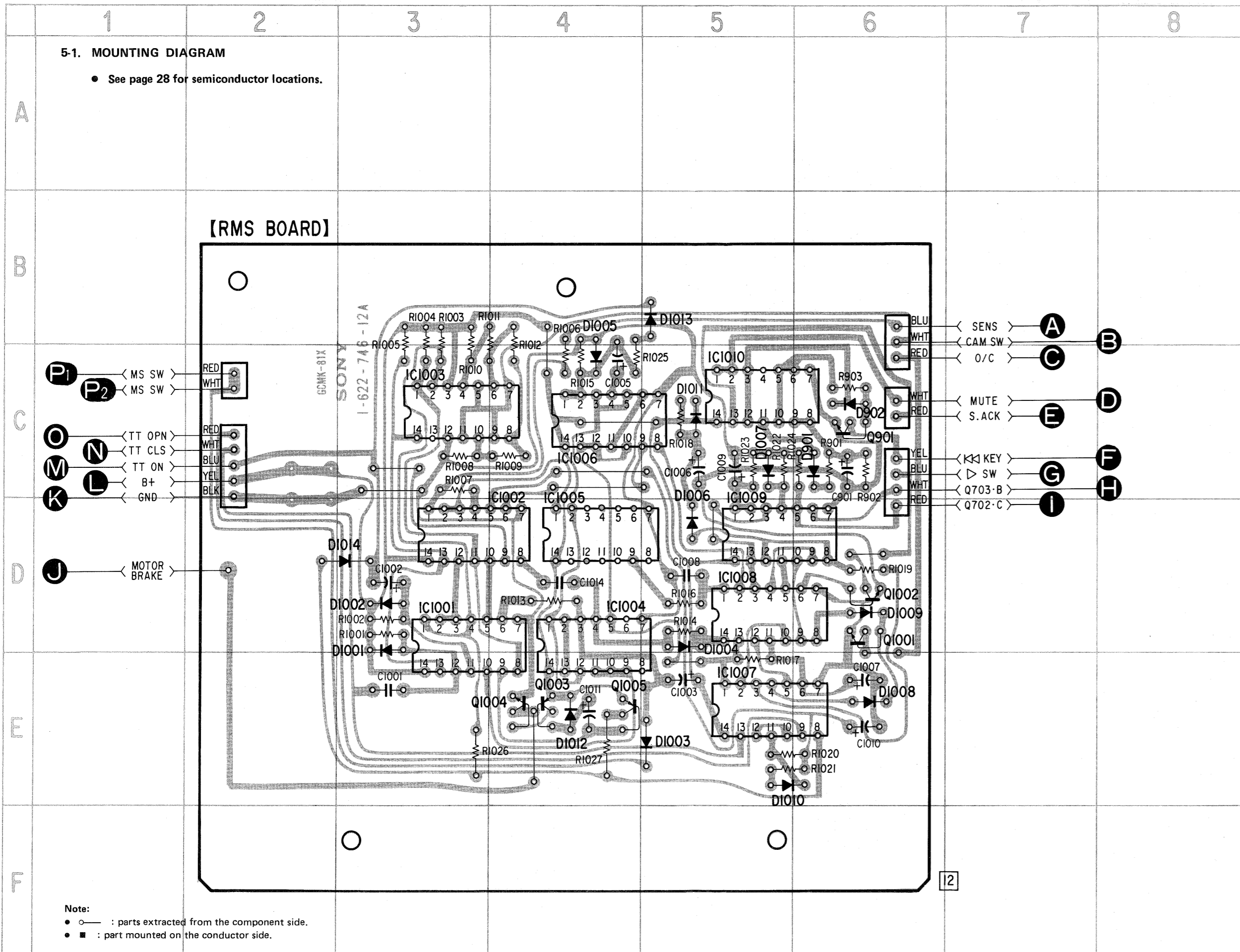

5-2. SCHEMATIC DIAGRAM

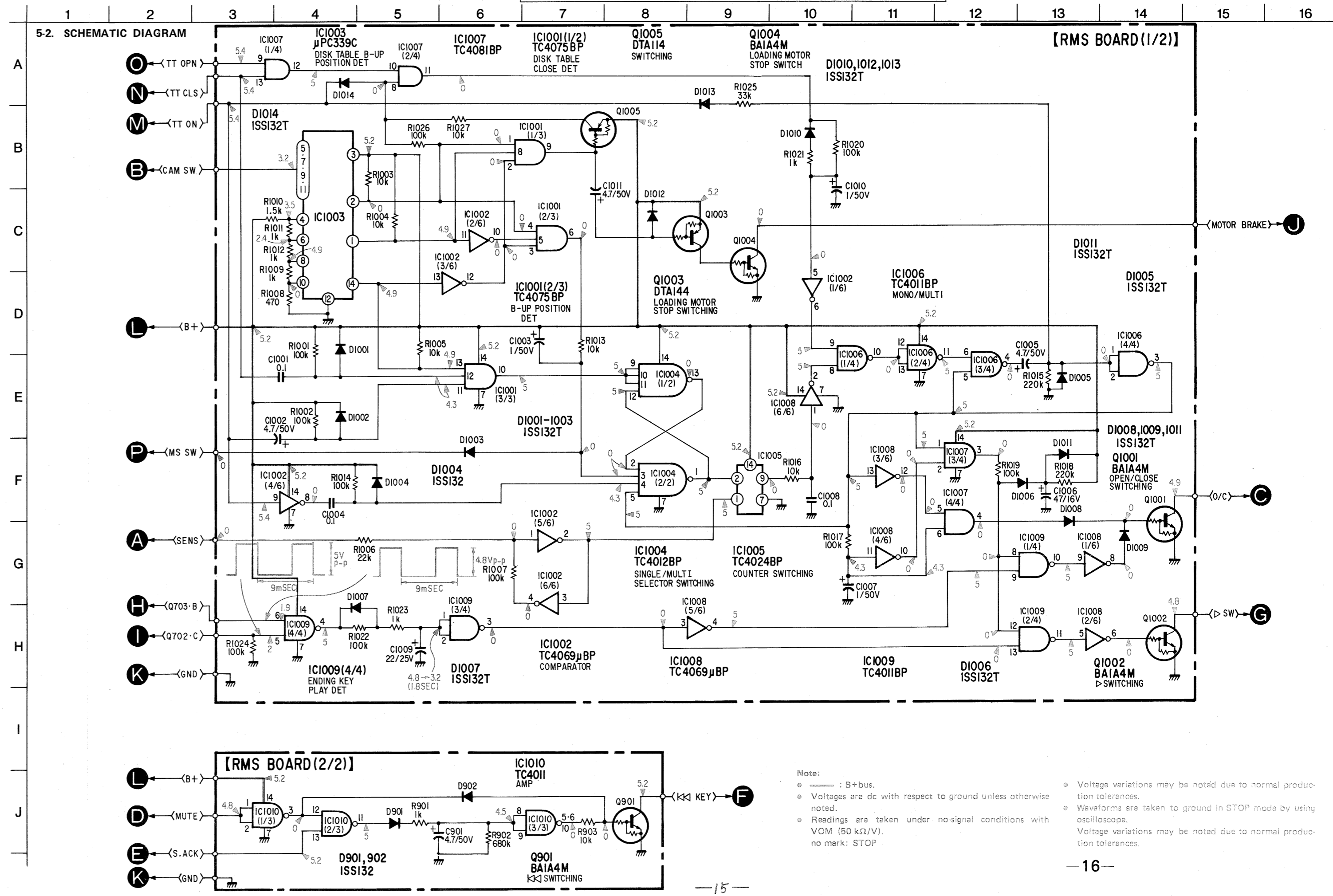

5-3. MOUNTING DIAGRAM

• See page 28 for semiconductor locations.

Note:
 • ○ : parts extracted from the component side.
 • ● : part mounted on the conductor side.

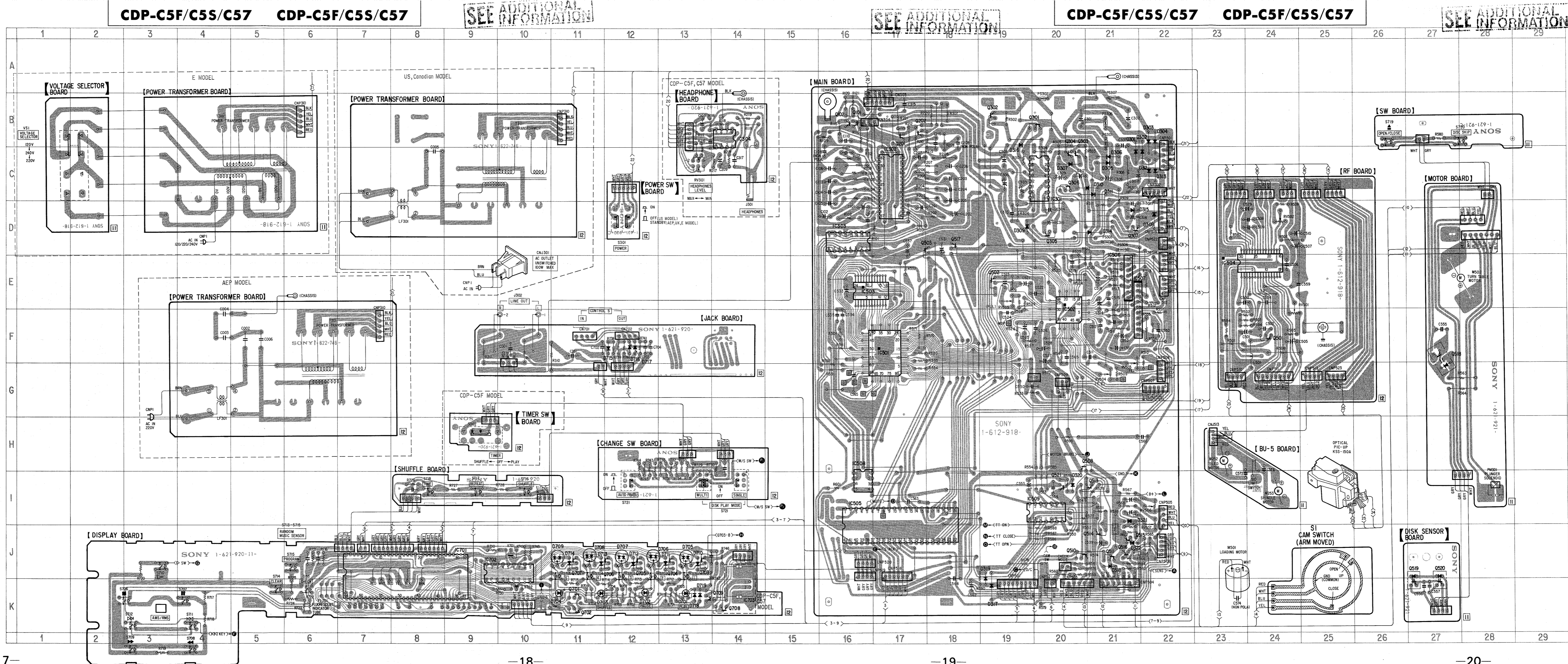

SEE ADDITIONAL INFORMATION

CDP-C5F/C5S/C57 CDP-C5F/C5S/C57

SEE ADDITIONAL INFORMATION

SEE ADDITIONAL INFORMATION

CDP-C5F/C5S/C57 CDP-C5F/C5S/C57

SEE ADDITIONAL INFORMATION

SEE ADDITIONAL INFORMATION

5-4. SCHEMATIC DIAGRAM • See page 26 for note.

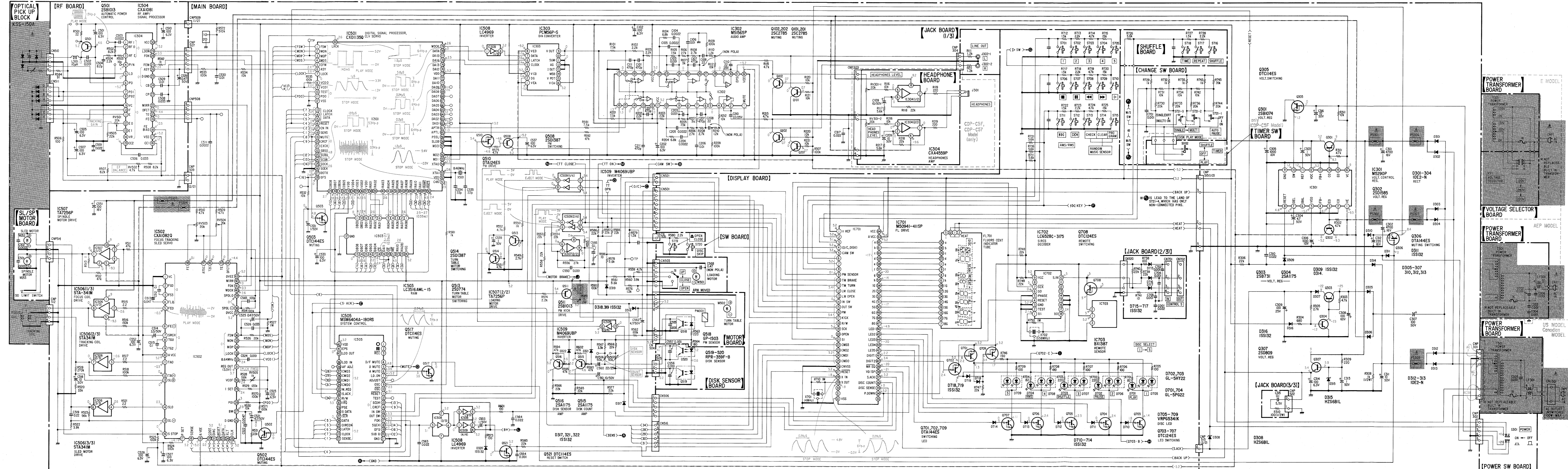

• IC BLOCK DIAGRAMS

Note on Schematic Diagram:

- All capacitors are in μF unless otherwise noted. pF: $\mu\mu\text{F}$ 50WV or less are not indicated except for electrolytics and tantalums.
- All resistors are in Ω and $1/4\text{W}$ or less unless otherwise specified.
- : nonflammable resistor.
- : B+ bus.
- : B- bus.
- : adjustment for repair.
- Voltages are dc with respect to ground unless otherwise noted.
- Readings are taken under no-signal conditions with a VOM (50 k Ω /V), no mark: STOP
- Voltage variations may be noted due to normal production tolerances.
- Waveforms are taken to ground in STOP mode by using oscilloscope.
- Voltage variations may be noted due to normal production tolerances.

• Switches:

Ref. No.	Switch	Position
S1	ARM MOVED	UP
S002	TIMER	OFF
S10	LIMIT	ON
S301	POWER	OFF
S701	1	OFF
S702	2	OFF
S703	3	OFF
S704	4	OFF
S705	5	OFF
S706	■	OFF
S707	■	OFF
S708	◀◀	OFF
S709	▶▶	OFF
S710	▷	OFF
S711	◀◀	OFF
S712	◀◀	OFF
S713	CHECK	OFF
S714	CLEAR	OFF
S715	PROGLAM	OFF
S716	SHUFFLE	OFF
S717	REPEAT	OFF
S718	TIME	OFF
S719	OPEN/CLOSE	CLOSE
S720	DISK SKIP	OFF
S721	DISK PLAY MODE	OFF
VS1	E model: VOLTAGE SELECTOR	120V

Note: The components identified by shading and mark are critical for safety. Replace only with part number specified.

Note: Les composants identifiés par une trame et une marque sont critiques pour la sécurité. Ne les remplacer que par une pièce portant le numéro spécifié.

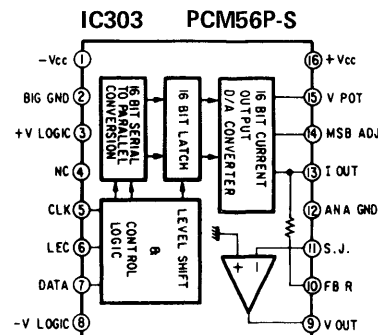

IC501 CXD1135Q

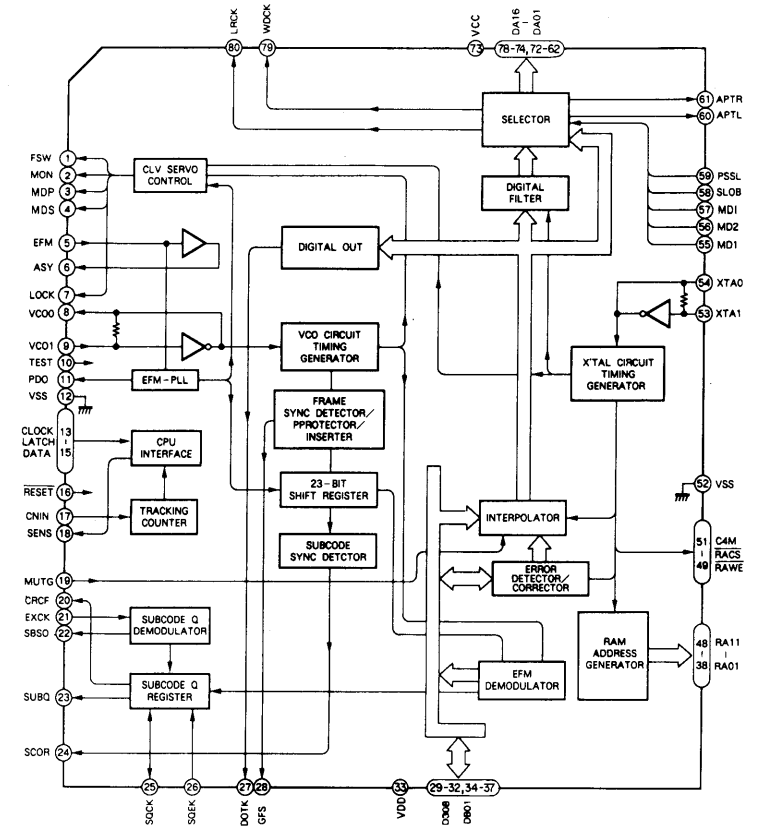

IC502 CXA1082Q

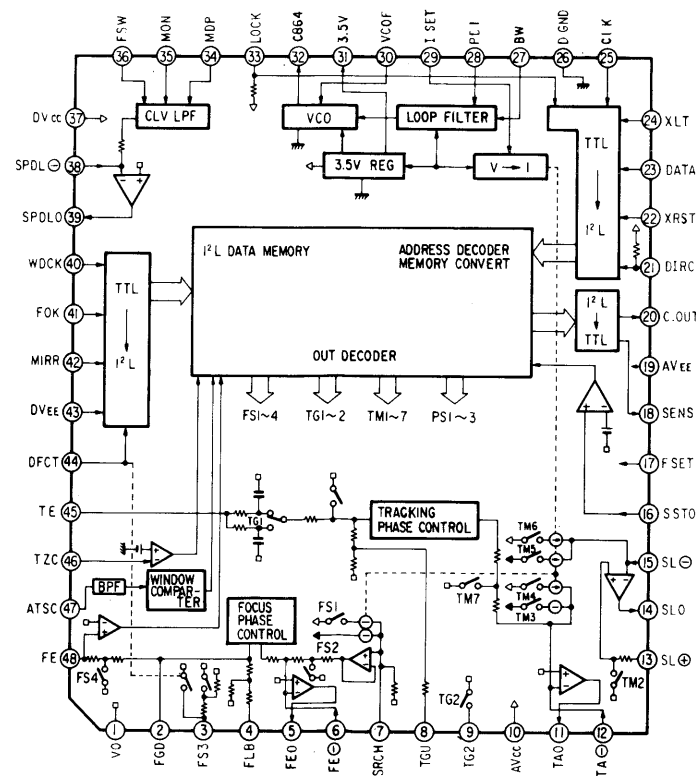

IC504 CXA1081M

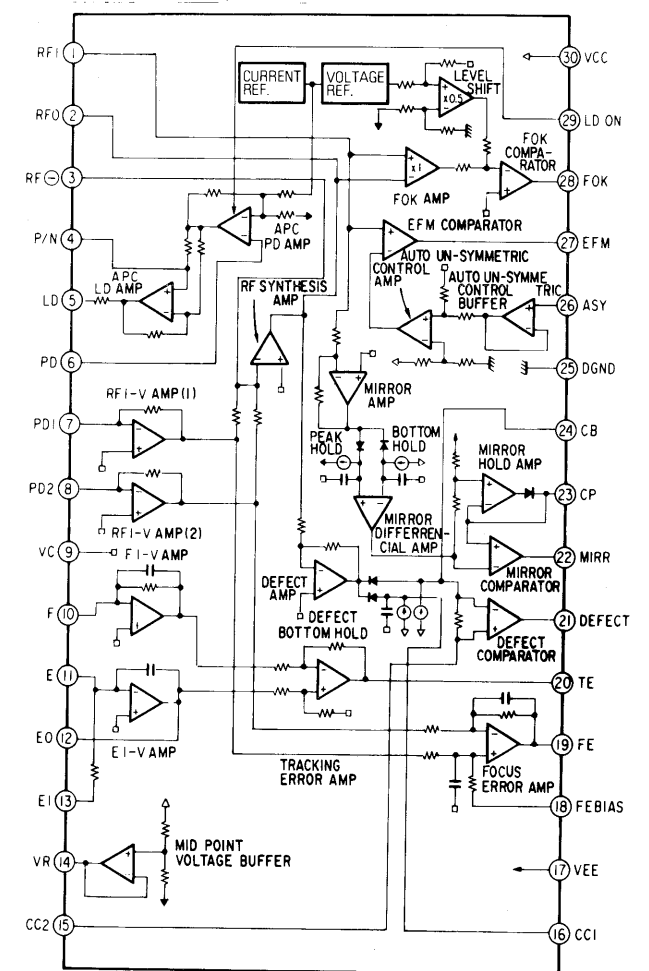

● SEMICONDUCTOR LOCATIONS







[MAIN BOARD]

Ref. No.	Location	Ref. No.	Location	Ref. No.	Location
D301	B-21	D711	J-12	Q302	B-19
D302	B-21	D712	J-12	Q303	B-20
D303	B-21	D713	J-11	Q304	B-20
D304	B-22	D714	J-11	Q305	B-20
D305	C-21	D715	F-11	Q306	C-20
D306	C-21	D716	F-12	Q307	D-21
D307	C-20	D717	F-12	Q501	F-24
D308	D-22	D718	K-13	Q502	E-19
D309	D-19	D719	K-13	Q503	D-17
D310	C-20			Q508	H-20
D311	C-20	IC301	C-20	Q510	J-20
D312	C-22	IC302	C-17	Q511	J-21
D313	C-22	IC303	D-16	Q513	I-20
D314	D-20	IC304	B-14	Q514	J-21
D315	D-21	IC501	F-17	Q515	J-21
D316	B-19	IC502	E-20	Q516	J-21
D317	K-19	IC503	E-16	Q517	D-18
D318	J-21	IC504	E-24	Q518	F-27
D319	J-18	IC505	I-16	Q519	J-26
D320	I-20	IC506	E-21	Q520	J-27
D321	I-21	IC507	E-21	Q521	I-20
D322	J-21	IC508	H-16	Q701	K-11
D701	K-13	IC509	I-19	Q702	K-11
D702	K-12	IC701	J-8	Q703	J-13
D703	K-11	IC702	J-9	Q704	J-13
D704	K-10	IC703	J-14	Q705	J-12
D705	J-13			Q706	J-11
D706	J-12	Q101	B-16	Q707	J-11
D707	J-12	Q102	B-16	Q708	K-14
D708	J-11	Q201	B-17	Q709	K-13
D709	J-10	Q202	B-17		
D710	J-13	Q301	B-19		

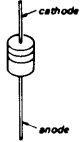
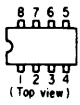
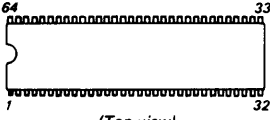
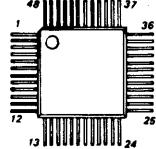
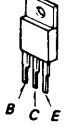
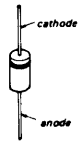
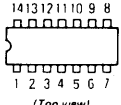
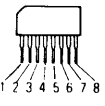
[RMS BOARD]

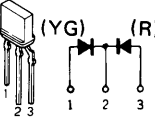
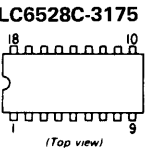
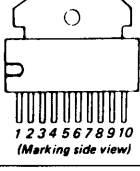
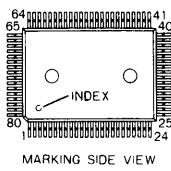
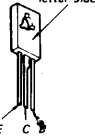
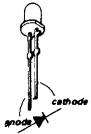
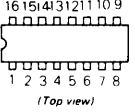
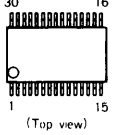
Ref. No.	Location	Ref. No.	Location	Ref. No.	Location
D901	C-6	D1011	C-5	IC1008	D-5
D902	C-6	D1012	E-4	IC1009	D-5
D1001	D-3	D1013	B-5	IC1010	C-5
D1002	D-3	D1014	D-3		
D1003	E-5			Q901	C-6
D1004	D-5	IC1001	D-3	Q1001	D-6
D1005	B-4	IC1002	D-4	Q1002	D-6
D1006	C-5	IC1003	C-3	Q1003	E-4
D1007	C-5	IC1004	D-4	Q1004	E-4
D1008	E-6	IC1005	D-4	Q1005	E-4
D1009	D-6	IC1006	C-4		
D1010	E-5	IC1007	E-5		

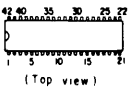
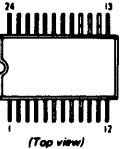
● Semiconductor Lead Layouts

<p>HZS6B1L</p> 	<p>CXA4559P LC4969</p>  <p>(Top view)</p>	<p>M50941-411SP</p>  <p>(Top view)</p>	<p>CXA-1082AQ</p> 	<p>2SB1094-L</p> 
<p>10E2N 1SS132</p> 	<p>M4069UBP TC4011BP TC4012BP TC4024BP TC4069μBP TC4075BP TC4081BP μPC339C</p>  <p>(Top view)</p>	<p>STA341M</p> 	<p>M51565P</p> 	<p>2SD774</p> 
<p>VRPG5341K</p> 	<p>LC6528C-3175</p>  <p>(Top view)</p>	<p>TA7256P</p>  <p>(Marking side view)</p>	<p>CXD1135Q</p>  <p>MARKING SIDE VIEW</p>	<p>2SB731 2SD809</p> 
<p>GL-5PG22 GL-5HY22</p> 	<p>M5290P PCM56P-S</p>  <p>(Top view)</p>	<p>CXA1081M</p>  <p>(Top view)</p>	<p>2SB1013 2SD1387</p> 	<p>2SA1175 2SC3623-L</p> 
<p>MSM6404A-180RS</p>  <p>(Top view)</p>	<p>LC3516AML-15</p>  <p>(Top view)</p>	<p>2SC3402 2SC3399 2SA1346 2SA1348 2SC3400</p> 		

SECTION 6 EXPLODED VIEWS AND PARTS LIST

NOTE:

• The mechanical parts with no reference number in the exploded views are not supplied.

• Items marked " * " are not stocked since they are seldom required for routine service. Some delay should be anticipated when ordering these items.

• The construction parts of an assembled part are indicated with a collation number in the remark column.

• Color Indication of Appearance Parts
Example: (RED) KNOB, BALANCE

Cabinet's Color Parts' Color

The components identified by shading and mark **▲** are critical for safety. Replace only with part number specified.

Les composants identifiés par une trame et une marque **▲** sont critiques pour la sécurité. Ne les remplacer que par une pièce portant le numéro spécifié.

6-1. FRONT PANEL

- **A:** POWER SW BOARD
 - **B:** TIMER SW BOARD
 - **C:** HEADPHONE BOARD
 - **D:** SHUFFLE BOARD
 - **E:** CHANGE SW BOARD
 - **F:** JACK BOARD
- (See page 32)

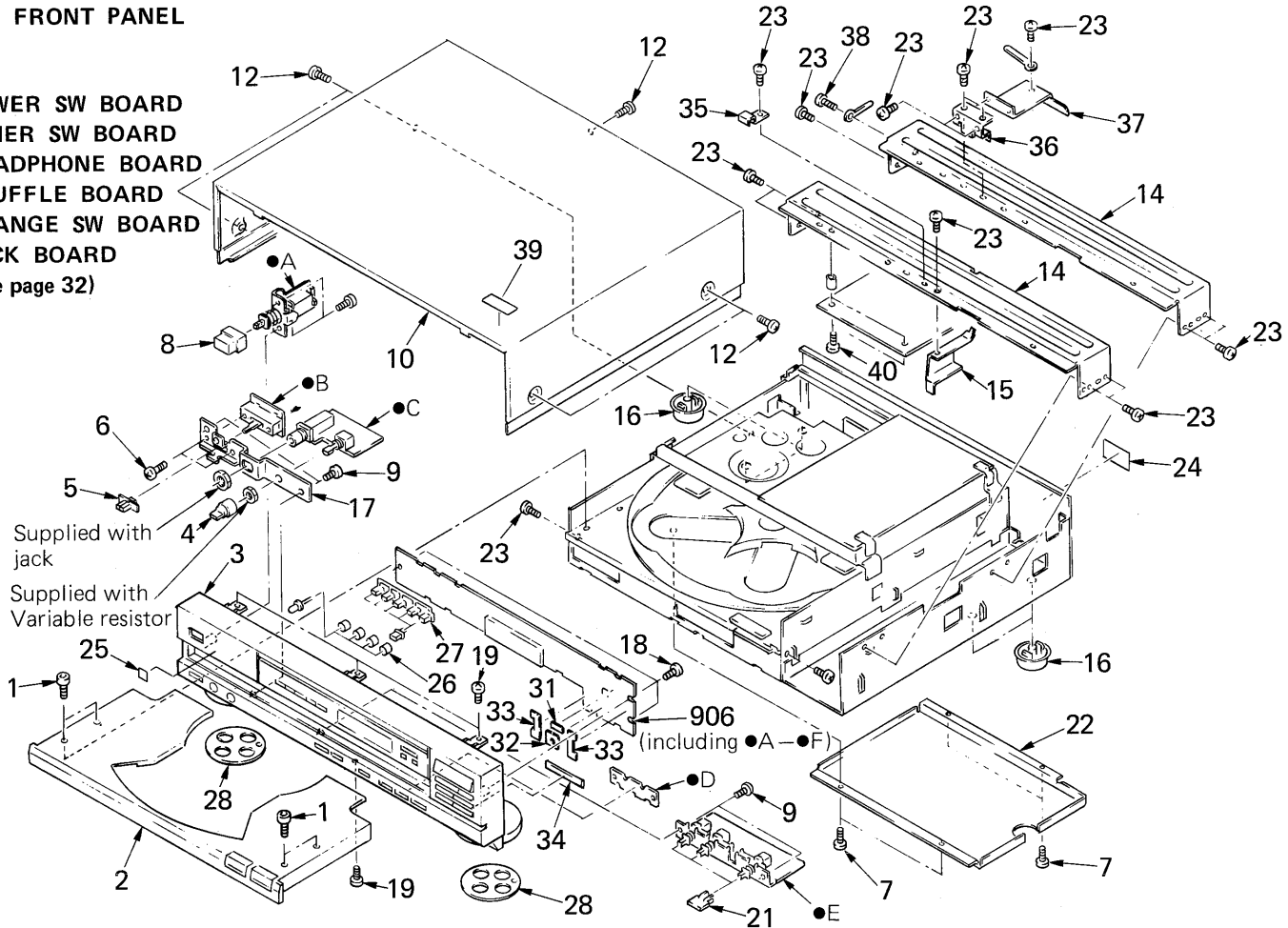

No.	Part No.	Description	Remarks	No.	Part No.	Description	Remarks
1	7-683-415-05	BOLT, HEXAGON SOCKET 2.6X12		21	4-919-409-01	BUTTON, SQUARE	
2	X-4919-402-1	(C5S)....COVER ASSY, STATION		22	*4-919-453-01	COVER, CHASSIS	
	X-4919-404-1	(C57)....COVER ASSY, STATION		23	7-685-870-09	SCREW +BVTT 3X5 (S)	
	X-4919-407-1	(C5F)....COVER ASSY, STATION		24	*4-885-838-00	(AEP,E)...LABEL, CLASS 1	
3	X-4919-401-1	(C5S).....PANEL ASSY, FRONT		25	3-703-713-41	STICKER, SONY SYMBOL (10)	
	X-4919-403-1	(C57).....PANEL ASSY, FRONT		26	*4-901-657-11	SPACER (A), LED	
	X-4919-405-1	(C5F:US,Canadian)...PANEL ASSY, FRONT		27	*4-919-445-01	HOLDER (B), LED	
	X-4919-406-1	(C5F:AEP,E).....PANEL ASSY, FRONT		28	4-917-236-01	FELT, FOOT	
4	3-304-929-11	KNOB, HEADPHONE		31	*4-919-495-01	CUSHION (A)	
5	4-887-131-00	(C5F)...KNOB, SLIDE SWITCH		32	*4-919-497-01	CUSHION (B)	
6	7-621-775-10	(EXCEPT C5S)...SCREW +B 2.6X4		33	*4-919-496-01	CUSHION (C)	
7	7-685-870-01	SCREW +BVTT 3X5 (S)		34	*4-921-020-02	CUSHION (PANEL)	
8	4-917-460-01	KNOB, POWER		35	*4-919-486-01	RETAINER	
9	7-685-146-14	SCREW +P 3X8 TYPE2 NON-SLIT		36	*4-921-014-01	REINFORCEMENT (SB)	
10	4-919-406-01	CASE		37	*4-921-016-01	REINFORCEMENT, CHUCKING BLOCK (BU-5 only) Refer to page 34	
12	7-682-147-09	SCREW, M3 CASE		38	7-685-750-09	SCREW +PTT 3X5 (S)	(●)
14	*4-919-405-01	REINFORCEMENT (L)		39	*4-919-488-01	LABEL, CAUTION	
15	*4-919-474-01	REINFORCEMENT (F)		40	7-685-874-09	BVTT 3X12	
16	X-3701-069-0	FOOT ASSY, M.F		906	*A-4655-039-A	(C5F)...MOUNTED PCB, INDICATION	
17	*4-919-415-01	BRACKET, FRONT PC BOARD			*A-4655-042-A	(C57)...MOUNTED PCB, INDICATION	
18	7-685-133-19	SCREW +P 2.6X6 TYPE2 SLIT			*A-4655-043-A	(C5S)...MOUNTED PCB, INDICATION	
19	7-682-148-01	SCREW +BVTT 3X8 (S)					

6-4. DISC TABLE

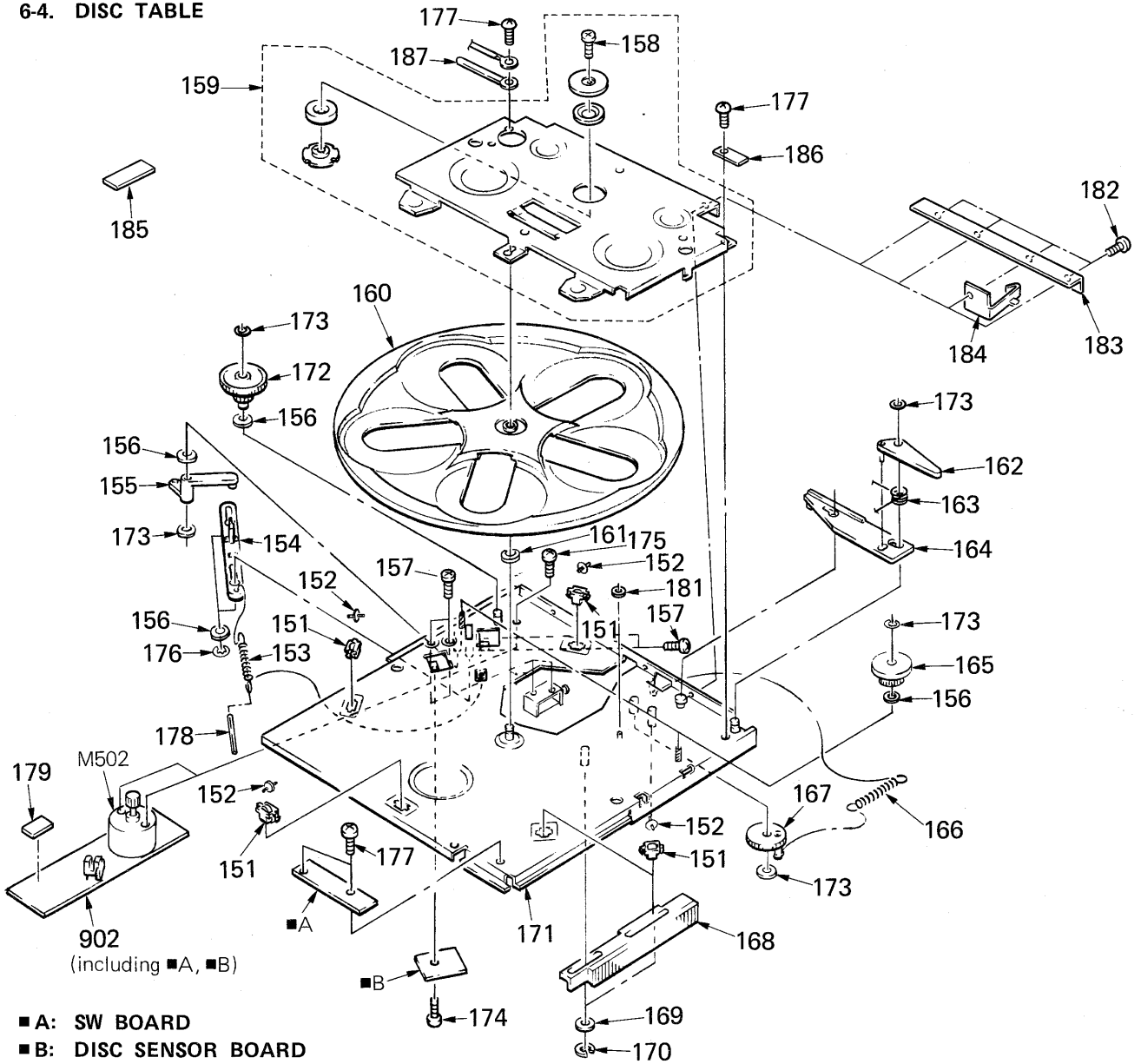

- A: SW BOARD
- B: DISC SENSOR BOARD

No.	Part No.	Description	Remarks	No.	Part No.	Description	Remarks
151	4-919-419-01	HOLDER, ROLLER		170	7-624-106-04	STOP RING 3.0, TYPE -E	
152	*X-4919-418-1	ROLLER (T) ASSY		171	*X-4919-412-1	BASE ASSY, STATION	
153	4-919-421-01	SPRING, TENSION		172	4-915-463-01	GEAR (A)	
154	4-919-451-01	SLIDER (ST)		173	3-558-708-21	WASHER, STOPPER	
155	4-919-416-01	LEVER (ST)		174	7-682-147-01	SCREW, S TIGHT, +PTTWH 3X6	
156	3-701-439-21	WASHER		175	7-621-775-08	SCREW +B 2.6X3	
157	7-682-545-09	SCREW +B 3X4		176	7-624-104-04	STOP RING 2.0, TYPE -E	
158	7-685-132-19	SCREW +P 2.6X5 TYPE 2 NON-SLIT		177	7-685-870-09	SCREW +BVTT 3X5 (S)	
159	A-4681-008-A	CHUCKING ASSY (BU-5)	Refer to 158	178	*4-921-008-01	CUSHION	
	A-4681-012-A	CHUCKING ASSY (BU-5A)	page 34.(●) 158	179	*4-919-489-01	CUSHION (PM)	
160	4-918-028-11	STATION, ROTARY		180	7-685-870-09	SCREW +BVTT 3X5 (S)	
161	3-701-443-21	WASHER, 5 (t=0.5)		181	*4-921-019-01	SPACER (ST)	
162	4-919-418-01	LEVER (S)		182	7-682-148-01	SCREW +BVTT 3X8 (S)	
163	4-919-420-01	SPRING		183	4-919-491-01	REINFORCEMENT (S)	
164	4-919-417-01	SLIDER (S)		184	*4-921-006-01	SPRING	
165	4-915-460-01	GEAR (B)		185	3-831-441-XX	CUSHION (B), CABINET	
166	4-910-429-01	SPRING, TENSION (LIMITER GEAR)		186	*4-921-013-01	NUT, PLATE	
167	4-910-401-01	GEAR, LIMITER		187	3-703-150-11	CLAMP	
168	4-919-450-01	RACK		902	*1-621-921-11	PC BOARD, TRAY	
169	7-688-004-11	W 4, MIDDLE		M502	X-4919-420-1	MOTOR ASSY, TURNTABLE	

6-5. BASE UNIT (BU-5) (BU-5A)

(●) BU-5A IDENTIFICATION
This portion can be indented.

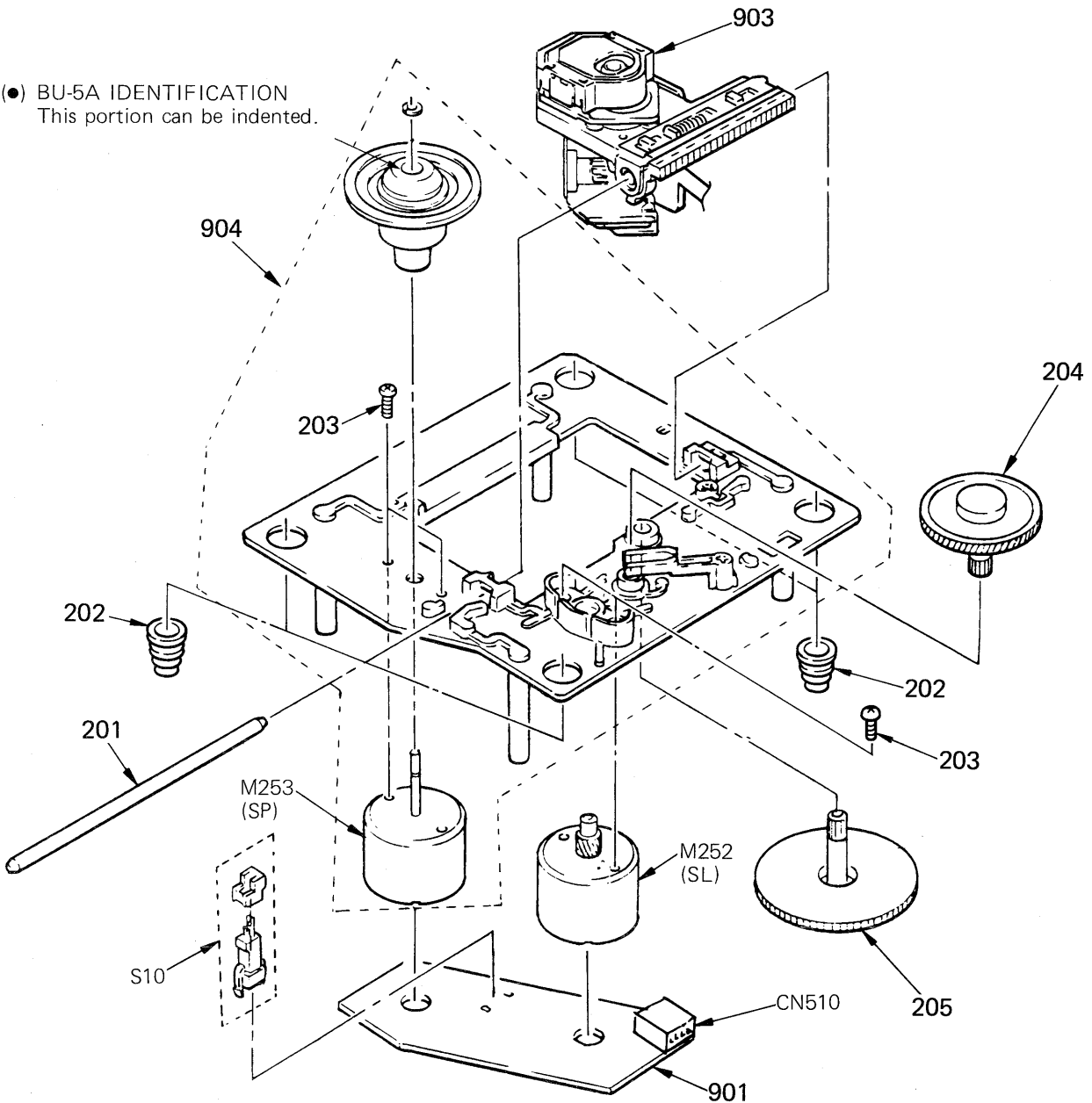

The components identified by shading and mark **A** are critical for safety. Replace only with part number specified.

Les composants identifiés par une trame et une marque **A** sont critiques pour la sécurité. Ne les remplacer que par une pièce portant le numéro spécifié.

No.	Part No.	Description
201	4-917-565-01	SHAFT, SLED
202	4-917-562-01	INSULATOR
203	7-621-255-15	SCREW +P 2X3
204	4-917-567-01	GEAR (M)
205	4-917-564-01	GEAR (P), FLATNESS

Remarks

No.	Part No.	Description	Remarks
901	*1-620-097-11	PC BOARD, SL/SP MOTOR	
903	A 8-848-062-01	DEVICE, OPTICS (KSS-150A)	
904	X-4917-505-1	(BU-5) ... BASE ASSY	
	X-4917-523-1	(BU-5A) .. BASE ASSY (●)	
CN510	*1-564-720-31	PIN, CONNECTOR (SMALL TYPE) 4P	
M252	X-4917-504-1	MOTOR ASSY (SLED)	
S10	1-570-822-11	SWITCH, LEAF	

**SECTION 7
ELECTRICAL PARTS LIST**

NOTE:

- Items marked " * " are not stocked since they are seldom required for routine service. Some delay should be anticipated when ordering these items.
- If there are two or more same circuits in a set such as a stereophonic machine, only typical circuit parts may be indicated and capacitors and resistors in other same circuits may be omitted.

CAPACITORS:

MF:μF, PF:μμF.

RESISTORS

- All resistors are in ohms.
- F : nonflammable

COILS

• MMH : mH, UH : μH

SEMICONDUCTORS

In each case, U : μ, for example:
UA....: μA...., UPA....: μPA...., UPC....: μPC,
UPD....: μPD...

The components identified by shading and mark  are critical for safety. Replace only with part number specified.

Les composants identifiés par une trame et une marque  sont critiques pour la sécurité. Ne les remplacer que par une pièce portant le numéro spécifique.

ELECTRICAL PARTS

Ref.No.	Part No.	Description
901	*1-620-097-11	PC BOARD, SL/SP MOTOR
902	*1-621-921-11	PC BOARD, TRAY
903	*1-8-848-062-01	DEVICE, OPTICS (KSS-150A)
904	X-4917-505-1	(BU-5) ... BASE ASSY (BU-5A) .. BASE ASSY
905	*A-4651-121-A	(EXCEPT C5S:E)...MOUNTED PCB, MAIN
	*A-4651-122-A	(E).....MOUNTED PCB, MAIN
	*A-4651-123-A	(C5S).....MOUNTED PCB, MAIN
906	*A-4655-039-A	(C5F)....MOUNTED PCB, INDICATION
	*A-4655-042-A	(C57)....MOUNTED PCB, INDICATION
	*A-4655-043-A	(C5S)....MOUNTED PCB, INDICATION
907	1-526-565-00	(E)...ADAPTOR, AC PLUG
C001	1-161-494-00	CERAMIC 0.022MF 25V
C002	1-161-741-00	(AEP) CERAMIC 0.001MF 1 %
C003	1-161-741-00	(AEP) CERAMIC 0.001MF 10% 400V
C004	1-161-741-00	(AEP) CERAMIC 0.001MF 10% 400V
C005	1-161-741-00	(US, Canadian). CERAMIC 0.001MF 10% 400V
C006	1-161-741-00	(AEP) CERAMIC 0.001MF 10% 400V
C101	1-136-478-11	FILM 470PF 5% 630V
C102	1-126-023-11	ELECT 100MF 20% 25V
C103	1-130-273-00	FILM 0.001MF 5% 100V
C104	1-136-230-00	FILM 0.0022MF 5% 100V
C105	1-136-230-00	FILM 0.0022MF 5% 100V
C106	1-136-153-00	FILM 0.01MF 5% 50V
C107	1-130-467-00	MYLAR 470PF 5% 50V
C108	1-124-187-11	ELECT 22MF 20% 50V
C109	1-123-875-91	(EXCEPT C5S)..ELECT 10MF 20% 50V
C110	1-124-282-00	(EXCEPT C5S)..ELECT 22MF 20% 25V
C111	1-162-290-31	CERAMIC 470PF 10% 50V
C201	1-136-478-11	FILM 470PF 5% 630V
C202	1-126-023-11	ELECT 100MF 20% 25V
C203	1-130-273-00	FILM 0.001MF 5% 100V
C204	1-136-230-00	FILM 0.0022MF 5% 100V
C205	1-136-230-00	FILM 0.0022MF 5% 100V
C206	1-136-153-00	FILM 0.01MF 5% 50V
C207	1-130-467-00	MYLAR 470PF 5% 50V
C208	1-124-187-11	ELECT 22MF 20% 50V
C209	1-123-875-91	ELECT 10MF 20% 50V
C210	1-124-282-00	ELECT 22MF 20% 25V
C211	1-162-290-31	CERAMIC 470PF 10% 50V
C301	1-124-898-11	ELECT 4700MF 20% 16V
C302	1-124-898-11	ELECT 4700MF 20% 16V
C303	1-124-791-11	ELECT 1MF 20% 50V
C304	1-124-927-11	ELECT 4.7MF 20% 50V
C305	1-124-998-00	ELECT 1000MF 20% 10V
C306	1-124-998-00	ELECT 1000MF 20% 10V
C307	1-124-122-11	ELECT 100MF 20% 50V
C308	1-124-572-11	ELECT 100MF 20% 63V
C309	1-124-478-11	ELECT 100MF 20% 25V
C310	1-161-494-00	CERAMIC 0.022MF 25V

ELECTRICAL PARTS

Ref.No.	Part No.	Description
C311	1-123-875-91	ELECT 10MF 20% 50V
C312	1-123-321-00	ELECT 220MF 20% 16V
C313	1-124-791-11	ELECT 1MF 20% 50V
C314	1-124-468-11	ELECT 100MF 20% 6.3V
C315	1-125-367-11	SUPER CONDENSOR 0.1F 5.5V
C316	1-123-875-91	(EXCEPT C5F)..ELECT 10MF 20% 50V
C317	1-161-494-00	CERAMIC 0.022MF 25V
C501	1-124-468-11	ELECT 100MF 20% 6.3V
C502	1-162-294-31	CERAMIC 0.001MF 10% 50V
C503	1-130-475-00	MYLAR 0.0022MF 5% 50V
C504	1-162-198-31	CERAMIC 8.2PF 10% 50V
C505	1-124-468-11	ELECT 100MF 20% 6.3V
C506	1-136-159-00	FILM 0.033MF 5% 50V
C507	1-124-468-11	ELECT 100MF 20% 6.3V
C508	1-136-159-00	FILM 0.033MF 5% 50V
C509	1-136-153-00	FILM 0.01MF 5% 50V
C510	1-124-468-11	ELECT 100MF 20% 6.3V
C511	1-130-475-00	MYLAR 0.0022MF 5% 50V
C512	1-136-165-00	FILM 0.1MF 5% 50V
C513	1-136-161-00	FILM 0.047MF 5% 50V
C514	1-124-905-11	ELECT 3.3MF 20% 50V
C515	1-136-165-00	FILM 0.1MF 5% 50V
C518	1-123-875-91	ELECT 10MF 20% 50V
C519	1-136-169-00	FILM 0.22MF 5% 50V
C521	1-124-927-11	ELECT 4.7MF 20% 50V
C522	1-110-203-00	MYLAR 0.0047MF 5% 50V
C523	1-124-468-11	ELECT 100MF 20% 6.3V
C524	1-162-294-31	CERAMIC 0.001MF 10% 50V
C525	1-124-902-00	ELECT 0.47MF 20% 50V
C526	1-136-159-00	FILM 0.033MF 5% 50V
C527	1-124-468-11	ELECT 100MF 20% 6.3V
C528	1-124-468-11	ELECT 100MF 20% 6.3V
C529	1-124-902-00	ELECT 0.47MF 20% 50V
C530	1-136-153-00	FILM 0.01MF 5% 50V
C531	1-124-791-11	ELECT 1MF 20% 50V
C533	1-124-468-11	ELECT 100MF 20% 6.3V
C534	1-162-207-31	CERAMIC 22PF 5% 50V
C535	1-162-207-31	CERAMIC 22PF 5% 50V
C537	1-124-468-11	ELECT 100MF 20% 6.3V
C539	1-124-791-11	ELECT 1MF 20% 50V
C550	1-162-294-31	CERAMIC 0.001MF 10% 50V
C551	1-124-445-00	ELECT 100MF 20% 16V
C552	1-124-445-00	ELECT 100MF 20% 16V
C553	1-124-791-11	ELECT 1MF 20% 50V
C554	1-161-494-00	CERAMIC 0.022MF 25V

CDP-C5F/C5S/C5T

ELECTRICAL PARTS

Ref.No.	Part No.	Description			
C555	1-162-294-31	CERAMIC	0.001MF	10%	50V
C556	1-162-294-31	CERAMIC	0.001MF	10%	50V
C557	1-162-294-31	CERAMIC	0.001MF	10%	50V
C559	1-161-494-00	CERAMIC	0.022MF	30%	25V
C560	1-124-908-11	ELECT	22MF	20%	25V
C561	1-123-875-91	ELECT	10MF	20%	50V
C562	1-124-927-11	ELECT	4.7MF	20%	50V
C563	1-161-494-00	CERAMIC	0.022MF	30%	25V
C564	1-161-494-00	CERAMIC	0.022MF		25V
C565	1-162-282-31	CERAMIC	100PF	10%	50V
C566	1-136-165-00	FILM	0.1MF	5%	50V
C567	1-161-494-00	CERAMIC	0.022MF		25V
C568	1-161-377-00	CERAMIC	0.0047MF	30%	16V
C569	1-161-494-00	CERAMIC	0.022MF		25V
C571	1-161-494-00	CERAMIC	0.022MF		25V
C572	1-106-351-00	MYLAR	0.0022MF	5%	50V
C573	1-106-351-00	MYLAR	0.0022MF	5%	50V
C701	1-162-294-31	CERAMIC	0.001MF	10%	50V
C702	1-161-494-00	CERAMIC	0.022MF		25V
C703	1-161-494-00	CERAMIC	0.022MF		25V
C704	1-161-494-00	CERAMIC	0.022MF		25V
C705	1-161-494-00	CERAMIC	0.022MF		25V
C708	1-161-494-00	(C5S)...CERAMIC	0.022MF		25V
C709	1-161-494-00	(EXCEPT C5S) ...CERAMIC	0.022MF		25V
C710	1-161-494-00	CERAMIC	0.022MF		25V
C901	1-124-927-11	ELECT	4.7MF	20%	50V
C1001	1-136-165-00	FILM	0.1MF	5%	50V
C1002	1-124-927-11	ELECT	4.7MF	20%	50V
C1003	1-124-791-11	ELECT	1MF	20%	50V
C1004	1-136-165-00	FILM	0.1MF	5%	50V
C1005	1-124-927-11	ELECT	4.7MF	20%	50V
C1006	1-123-332-00	ELECT	47MF	20%	16V
C1007	1-124-791-11	ELECT	1MF	20%	50V
C1008	1-136-165-00	FILM	0.1MF	5%	50V
C1009	1-124-908-11	ELECT	22MF	20%	25V
C1010	1-124-791-11	ELECT	1MF	20%	50V
C1011	1-124-927-11	ELECT	4.7MF	20%	50V
CN301	*1-564-508-11	PLUG, CONNECTOR 5P			
CN302	*1-564-339-51	PIN, CONNECTOR 5P			
CN303	*1-564-340-51	(EXCEPT C5S)...PIN, CONNECTOR 6P			
CN304	*1-564-506-11	PLUG, CONNECTOR 3P			
CN501	*1-506-503-11	PIN, CONNECTOR 9P			
CN503	*1-564-509-11	PLUG, CONNECTOR 6P			
CN504	*1-564-510-11	PLUG, CONNECTOR 7P			
CN505	*1-564-507-11	PLUG, CONNECTOR 4P			
CN506	*1-564-339-41	PIN, CONNECTOR 5P			
CN507	*1-564-339-21	PIN, CONNECTOR 5P			
CN508	*1-564-338-21	PIN, CONNECTOR 4P			
CN509	*1-564-337-21	PIN, CONNECTOR 3P			
CN510	*1-564-720-31	PIN, CONNECTOR (SMALL TYPE) 4P			
CN511	*1-564-724-11	PIN, CONNECTOR (SMALL TYPE) 8P			
CN512	*1-564-338-41	PIN, CONNECTOR 4P			
CN513	*1-564-720-11	PIN, CONNECTOR (SMALL TYPE) 4P			
CN514	*1-564-338-31	PIN, CONNECTOR 4P			
CN515	*1-564-509-11	PLUG, CONNECTOR 6P			
CN516	*1-564-340-21	PIN, CONNECTOR 6P			

The components identified by shading and mark **A** are critical for safety. Replace only with part number specified.

Les composants identifiés par une trame et une marque **A** sont critiques pour la sécurité. Ne les remplacer que par une pièce portant le numéro spécifié.

ELECTRICAL PARTS

Ref.No.	Part No.	Description
CN519	*1-564-338-51	PIN, CONNECTOR 4P
CN520	*1-564-338-00	PIN, CONNECTOR 4P
CN521	*1-564-336-21	PIN, CONNECTOR 2P
CN522	*1-564-336-61	PIN, CONNECTOR 2P
CN524	*1-564-336-00	PIN, CONNECTOR 2P
CN525	*1-564-720-21	PIN, CONNECTOR (SMALL TYPE) 4P
CN701	1-564-980-11	PIN, CONNECTOR 4P
CN702	1-564-980-11	PIN, CONNECTOR 4P
CN704	*1-564-337-00	PIN, CONNECTOR 3P
CN705	*1-564-337-21	PIN, CONNECTOR 3P
A CNJ301	1-526-882-00	(US,Canadian)...OUTLET, AC (AC OUTLET)
CNJ513	*1-564-720-11	PIN, CONNECTOR (SMALL TYPE) 4P
CNP1	A 1-551-472-00	(E)...CORD, POWER
CNP1	A 1-551-478-00	(US,Canadian)...CORD, POWER
CNP1	A 1-555-795-00	(AEP)...CORD, POWER, EURO PLUG
D301	8-719-200-77	DIODE 10E2N
D302	8-719-200-77	DIODE 10E2N
D303	8-719-200-77	DIODE 10E2N
D304	8-719-200-77	DIODE 10E2N
D305	8-719-200-77	DIODE 10E2N
D306	8-719-200-77	DIODE 10E2N
D307	8-719-200-77	DIODE 10E2N
D308	8-719-933-36	ZENER HZS6B1L
D309	8-719-940-76	DIODE 1SS132
D310	8-719-200-77	DIODE 10E2N
D311	8-719-940-76	DIODE 1SS132
D312	8-719-200-77	DIODE 10E2N
D313	8-719-200-77	DIODE 10E2N
D314	8-719-940-76	DIODE 1SS132
D315	8-719-933-36	ZENER HZS6B1L
D316	8-719-940-76	DIODE 1SS132
D317	8-719-940-76	DIODE 1SS132
D318	8-719-940-76	DIODE 1SS132
D319	8-719-940-76	DIODE 1SS132
D320	8-719-940-76	DIODE 1SS132
D321	8-719-940-76	DIODE 1SS132
D322	8-719-940-76	DIODE 1SS132
D701	8-719-907-98	LED GL-5PG22
D702	8-719-906-44	LED GL-5HY22
D703	8-719-906-44	LED GL-5HY22
D704	8-719-907-98	LED GL-5PG22
D705	8-719-945-54	LED VRPG5341K
D706	8-719-945-54	LED VRPG5341K
D707	8-719-945-54	LED VRPG5341K
D708	8-719-945-54	LED VRPG5341K
D709	8-719-945-54	LED VRPG5341K
D710	8-719-940-76	DIODE 1SS132
D711	8-719-940-76	DIODE 1SS132
D712	8-719-940-76	DIODE 1SS132
D713	8-719-940-76	DIODE 1SS132
D714	8-719-940-76	DIODE 1SS132
D715	8-719-940-76	DIODE 1SS132
D716	8-719-940-76	DIODE 1SS132
D717	8-719-940-76	DIODE 1SS132
D718	8-719-940-76	DIODE 1SS132
D719	8-719-940-76	DIODE 1SS132
D901	8-719-940-76	DIODE 1SS132
D902	8-719-940-76	DIODE 1SS132

ELECTRICAL PARTS

Ref.No.	Part No.	Description
D1001	8-719-940-76	DIODE 1SS132
D1002	8-719-940-76	DIODE 1SS132
D1003	8-719-940-76	DIODE 1SS132
D1004	8-719-940-76	DIODE 1SS132
D1005	8-719-940-76	DIODE 1SS132
D1014	8-719-940-76	DIODE 1SS132
FL701	1-519-304-00	INDICATOR TUBE, FLUORESCENT
IC301	8-759-604-03	IC M5290P
IC302	8-759-604-00	IC M51565P
IC303	8-759-937-95	IC PCM56P-S
IC304	8-759-701-12	(EXCEPT C5S)...IC CXA4559P
IC501	8-752-322-05	IC CXD1135Q
IC502	8-752-031-61	IC CXA1082AQ
IC503	8-759-802-74	IC LC3516AML-15
IC504	8-752-030-93	IC CXA1081M
IC505	8-759-940-62	IC MSM6404A-180RS
IC506	8-759-303-90	IC STA341M
IC507	8-759-202-01	IC TA7256P
IC508	8-759-803-41	IC LC4969
IC509	8-759-601-45	IC M4069UBP
IC701	8-759-604-74	IC M50941-411SP
IC702	8-759-803-33	IC LC6528C-3175
IC703	8-741-138-70	(EXCEPT C5S)...IC BX-1387
IC1001	8-759-240-75	IC TC4075BP
IC1002	8-759-240-69	IC TC4069UBP
IC1003	8-759-133-90	IC UPC339C
IC1004	8-759-240-12	IC TC4012BP
IC1005	8-759-240-24	IC TC4024BP
IC1006	8-759-240-11	IC TC4011BP
IC1007	8-759-240-81	IC TC4081BP
IC1008	8-759-240-69	IC TC4069UBP
IC1009	8-759-240-11	IC TC4011BP
IC1010	8-759-240-11	IC TC4011BP
J301	1-563-485-21	(EXCEPT C5S)...JACK, LARGE TYPE (HEADPHONES)
J302	*1-562-999-21	JACK, PIN 2P (LINE OUT)
L501	1-408-117-00	MICRO INDUCTOR 10UH
L701	1-407-173-XX	MICRO INDUCTOR 220UH
LF301	1-421-915-11	COIL, LINE FILTER
M252	X-4917-504-1	MOTOR ASSY (SLED)
M501	X-4919-419-1	MOTOR ASSY, LOADING
M502	X-4919-420-1	MOTOR ASSY, TURNTABLE
PM301	1-454-438-11	SOLENOID, PLUNGER
△PS301	1-532-637-00	LINK, IC
△PS302	1-532-637-00	LINK, IC
△PS303	1-532-605-00	LINK, IC
△PS304	1-532-605-00	LINK, IC
△PS305	1-532-637-00	LINK, IC
△PS306	1-532-686-00	LINK, IC
△PS307	1-532-686-00	LINK, IC
Q101	8-729-107-77	TRANSISTOR 2SC3623-L
Q102	8-729-107-77	TRANSISTOR 2SC3623-L
Q201	8-729-107-77	TRANSISTOR 2SC3623-L
Q202	8-729-107-77	TRANSISTOR 2SC3623-L
Q301	8-729-111-67	TRANSISTOR 2SB1094-L
Q302	8-729-107-25	TRANSISTOR 2SD1585-L
Q303	8-729-173-13	TRANSISTOR 2SB731
Q304	8-729-117-54	TRANSISTOR 2SA1175
Q305	8-729-806-28	TRANSISTOR 2SC3402

ELECTRICAL PARTS

Ref.No.	Part No.	Description
Q306	8-729-806-16	TRANSISTOR 2SA1346
Q307	8-729-180-93	TRANSISTOR 2SD809
Q501	8-729-801-83	TRANSISTOR 2SB1013
Q502	8-729-806-38	TRANSISTOR 2SC3399
Q503	8-729-806-38	TRANSISTOR 2SC3399
Q508	8-729-801-93	TRANSISTOR 2SD1387
Q510	8-729-806-16	TRANSISTOR 2SA1346
Q511	8-729-801-83	TRANSISTOR 2SB1013
Q513	8-729-177-43	TRANSISTOR 2SD774
Q514	8-729-801-93	TRANSISTOR 2SD1387
Q515	8-729-117-54	TRANSISTOR 2SA1175
Q516	8-729-117-54	TRANSISTOR 2SA1175
Q517	8-729-806-28	TRANSISTOR 2SC3402
Q518	8-719-906-43	TRANSISTOR GP-1S03
Q519	8-719-939-88	TRANSISTOR RPR-359F-B
Q520	8-719-939-88	TRANSISTOR RPR-359F-B
Q521	8-729-806-28	TRANSISTOR 2AC3402
Q701	9-986-159-01	TRANSISTOR 2SA1348
Q702	9-986-159-01	TRANSISTOR 2SA1348
Q703	8-729-806-34	TRANSISTOR 2SC3400
Q704	8-729-806-34	TRANSISTOR 2SC3400
Q705	8-729-806-34	TRANSISTOR 2SC3400
Q706	8-729-806-34	TRANSISTOR 2SC3400
Q707	8-729-806-34	TRANSISTOR 2SC3400
Q708	8-729-806-34	(EXCEPT C5S)...TRANSISTOR 2SC3400
Q709	9-986-159-01	TRANSISTOR 2SA1348
Q901	8-729-806-28	TRANSISTOR 2SC3402
Q1001	8-729-806-28	TRANSISTOR 2SC3402
Q1002	8-729-806-28	TRANSISTOR 2SC3402
Q1003	8-729-900-65	TRANSISTOR DTA144ES
Q1004	8-729-806-28	TRANSISTOR 2SC3402
Q1005	8-729-900-61	TRANSISTOR DTA114ES
R000	1-247-739-11	CARBON 100 5% 1/2W
R101	1-215-442-00	CARBON 7.5K 5% 1/6W
R102	1-247-717-11	CARBON 2.2K 5% 1/4W
R103	1-247-717-11	CARBON 2.2K 5% 1/4W
R104	1-247-723-11	CARBON 6.8K 5% 1/4W
R105	1-247-152-00	CARBON 7.5K 5% 1/4W
R106	1-249-933-11	CARBON 2.7K 1% 1/4W
R107	1-249-934-11	CARBON 3K 1% 1/4W
R108	1-249-933-11	CARBON 2.7K 1% 1/4W
R109	1-249-441-11	CARBON 100K 5% 1/6W
R110	1-247-714-11	CARBON 1.2K 5% 1/4W
R111	1-247-714-11	CARBON 1.2K 5% 1/4W
R112	1-249-429-11	CARBON 10K 5% 1/6W
R115	1-249-425-11	CARBON 4.7K 5% 1/6W
R116	1-249-429-11	(EXCEPT C5S)...CARBON 10K 5% 1/6W
R117	1-247-849-00	(EXCEPT C5S)...CARBON 5.6K 5% 1/6W
R118	1-249-433-11	(EXCEPT C5S)...CARBON 22K 5% 1/6W
R119	1-247-704-11	(EXCEPT C5S)...CARBON 220 5% 1/4W
R120	1-249-429-11	CARBON 10K 5% 1/6W
R121	1-249-429-11	CARBON 10K 5% 1/6W
R201	1-215-442-00	CARBON 7.5K 5% 1/6W
R202	1-247-717-11	CARBON 2.2K 5% 1/4W
R203	1-247-717-11	CARBON 2.2K 5% 1/4W
R204	1-247-723-11	CARBON 6.8K 5% 1/4W

The components identified by shading and mark **△** are critical for safety. Replace only with part number specified.

Les composants identifiés par une trame et une marque **△** sont critiques pour la sécurité. Ne les remplacer que par une pièce portant le numéro spécifié.

CDP-C5F/C5S/C57

ELECTRICAL PARTS

Ref.No.	Part No.	Description			
R205	1-247-152-00	CARBON	7.5K	5%	1/4W
R206	1-249-933-11	CARBON	2.7K	1%	1/4W
R207	1-249-934-11	CARBON	3K	1%	1/4W
R208	1-249-933-11	CARBON	2.7K	1%	1/4W
R209	1-249-441-11	CARBON	100K	5%	1/6W
R210	1-247-714-11	CARBON	1.2K	5%	1/4W
R211	1-247-714-11	CARBON	1.2K	5%	1/4W
R212	1-249-429-11	CARBON	10K	5%	1/6W
R215	1-249-425-11	CARBON	4.7K	5%	1/6W
R216	1-249-429-11	(EXCEPT C5S)...CARBON	10K	5%	1/6W
R217	1-247-849-00	(EXCEPT C5S)...CARBON	5.6K	5%	1/6W
R218	1-249-433-11	(EXCEPT C5S)...CARBON	22K	5%	1/6W
R219	1-247-704-11	(EXCEPT C5S)...CARBON	220	5%	1/4W
R220	1-249-429-11	CARBON	10K	5%	1/6W
R221	1-249-429-11	CARBON	10K	5%	1/6W
R301	1-249-425-11	CARBON	4.7K	5%	1/6W
R302	1-249-425-11	CARBON	4.7K	5%	1/6W
R303	1-249-425-11	CARBON	4.7K	5%	1/6W
R304	1-249-415-11	CARBON	680	5%	1/6W
R305	1-249-422-11	CARBON	2.7K	5%	1/6W
R306	1-249-433-11	CARBON	22K	5%	1/6W
R307	1-249-441-11	CARBON	100K	5%	1/6W
R308	1-247-752-11	CARBON	1K	5%	1/2W
R309	1-247-704-11	CARBON	220	5%	1/4W
R310	1-247-739-11	CARBON	100	5%	1/2W
R311	1-249-429-11	CARBON	10K	5%	1/6W
R501	1-214-092-00	METAL	22	1%	1/4W
R502	1-249-428-11	CARBON	8.2K	5%	1/6W
R503	1-215-450-00	CARBON	16K	5%	1/6W
R504	1-249-421-11	CARBON	2.2K	5%	1/6W
R505	1-249-433-11	CARBON	22K	5%	1/6W
R506	1-249-405-11	CARBON	100	5%	1/6W
R507	1-249-428-11	CARBON	8.2K	5%	1/6W
R508	1-249-428-11	CARBON	8.2K	5%	1/6W
R509	1-215-437-00	METAL	4.7K	1%	1/6W
R510	1-215-437-00	METAL	4.7K	1%	1/6W
R511	1-249-437-11	CARBON	47K	5%	1/6W
R512	1-249-437-11	CARBON	47K	5%	1/6W
R513	1-249-447-11	CARBON	1	5%	1/4W
R514	1-249-441-11	CARBON	100K	5%	1/6W
R515	1-249-385-11	CARBON	2.2	5%	1/6W
R516	1-247-883-00	CARBON	150K	5%	1/6W
R517	1-249-385-11	CARBON	2.2	5%	1/6W
R518	1-249-441-11	CARBON	100K	5%	1/6W
R519	1-215-479-00	CARBON	270K	5%	1/6W
R520	1-249-435-11	CARBON	33K	5%	1/6W
R521	1-249-385-11	CARBON	2.2	5%	1/6W
R522	1-249-424-11	CARBON	3.9K	5%	1/6W
R524	1-215-486-00	CARBON	510K	5%	1/6W
R525	1-249-441-11	CARBON	100K	5%	1/6W
R526	1-215-452-00	CARBON	20K	5%	1/6W
R527	1-215-493-00	CARBON	1M	5%	1/6W
R528	1-215-434-00	METAL	3.6K	1%	1/6W
R529	1-247-881-00	CARBON	120K	5%	1/6W
R530	1-249-429-11	CARBON	10K	5%	1/6W
R531	1-249-433-11	CARBON	22K	5%	1/6W
R532	1-249-429-11	CARBON	10K	5%	1/6W

ELECTRICAL PARTS

Ref.No.	Part No.	Description			
R533	1-249-441-11	CARBON	100K	5%	1/6W
R534	1-249-429-11	CARBON	10K	5%	1/6W
R535	1-249-441-11	CARBON	100K	5%	1/6W
R549	1-249-422-11	CARBON	2.7K	5%	1/6W
R550	1-249-417-11	CARBON	1K	5%	1/6W
R551	1-249-425-11	CARBON	4.7K	5%	1/6W
R552	1-249-425-11	CARBON	4.7K	5%	1/6W
R553	1-249-433-11	CARBON	22K	5%	1/6W
R554	1-249-433-11	CARBON	22K	5%	1/6W
R555	1-249-447-11	CARBON	1	5%	1/4W
R556	1-249-434-11	CARBON	27K	5%	1/6W
R557	1-249-433-11	CARBON	22K	5%	1/6W
R559	1-249-425-11	CARBON	4.7K	5%	1/6W
R560	1-249-424-11	CARBON	3.9K	5%	1/6W
R561	1-247-849-00	CARBON	5.6K	5%	1/6W
R562	1-249-441-11	CARBON	100K	5%	1/6W
R563	1-246-457-00	CARBON	220	5%	1/4W
R564	1-246-455-00	CARBON	180	5%	1/4W
R565	1-249-433-11	CARBON	22K	5%	1/6W
R566	1-249-433-11	CARBON	22K	5%	1/6W
R567	1-249-423-11	CARBON	3.3K	5%	1/6W
R568	1-249-433-11	CARBON	22K	5%	1/6W
R570	1-215-469-00	METAL	100K	1%	1/6W
R571	1-215-469-00	METAL	100K	1%	1/6W
R572	1-215-486-00	CARBON	510K	5%	1/6W
R573	1-249-405-11	CARBON	100	5%	1/6W
R574	1-249-421-11	CARBON	2.2K	5%	1/6W
R575	1-249-425-11	CARBON	4.7K	5%	1/6W
R576	1-249-419-11	CARBON	1.5K	5%	1/6W
R577	1-249-433-11	CARBON	22K	5%	1/6W
R578	1-247-849-00	CARBON	5.6K	5%	1/6W
R579	1-249-419-11	CARBON	1.5K	5%	1/6W
R580	1-249-421-11	CARBON	2.2K	5%	1/6W
R581	1-249-417-11	CARBON	1K	5%	1/6W
R582	1-249-417-11	CARBON	1K	5%	1/6W
R584	1-215-396-00	CARBON	91	5%	1/6W
R585	1-249-433-11	CARBON	22K	5%	1/6W
R586	1-249-433-11	CARBON	22K	5%	1/6W
R587	1-249-433-11	CARBON	22K	5%	1/6W
R588	1-249-433-11	CARBON	22K	5%	1/6W
R589	1-215-881-11	METAL OXIDE	15	5%	2W
R590	1-249-441-11	CARBON	100K	5%	1/6W
R591	1-249-417-11	CARBON	1K	5%	1/6W
R592	1-249-417-11	CARBON	1K	5%	1/6W
R593	1-249-437-11	CARBON	47K	5%	1/6W
R594	1-249-437-11	CARBON	47K	5%	1/6W
R595	1-249-437-11	CARBON	47K	5%	1/6W
R596	1-249-393-11	CARBON	10	5%	1/6W
R597	1-249-417-11	CARBON	1K	5%	1/6W
R598	1-249-417-11	CARBON	1K	5%	1/6W
R601	1-249-405-11	CARBON	100	5%	1/6W
R602	1-249-437-11	CARBON	47K	5%	1/6W
R701	1-249-404-00	CARBON	82	5%	1/6W
R702	1-249-409-11	CARBON	220	5%	1/6W
R703	1-249-409-11	CARBON	220	5%	1/6W
R704	1-249-404-00	CARBON	82	5%	1/6W
R705	1-249-405-11	CARBON	100	5%	1/6W

The components identified by shading and mark **A** are critical for safety. Replace only with part number specified.

Les composants identifiés par une trame et une marque **A** sont critiques pour la sécurité. Ne les remplacer que par une pièce portant le numéro spécifié.

ELECTRICAL PARTS

Ref.No.	Part No.	Description			
R706	1-249-405-11	CARBON	100	5%	1/6W
R707	1-249-405-11	CARBON	100	5%	1/6W
R708	1-249-405-11	CARBON	100	5%	1/6W
R709	1-249-405-11	CARBON	100	5%	1/6W
R710	1-215-493-00	CARBON	1M	5%	1/6W
R711	1-247-849-00	CARBON	5.6K	5%	1/6W
R712	1-249-419-11	CARBON	1.5K	5%	1/6W
R713	1-249-421-11	CARBON	2.2K	5%	1/6W
R714	1-249-425-11	CARBON	4.7K	5%	1/6W
R715	1-249-431-11	CARBON	15K	5%	1/6W
R716	1-247-849-00	CARBON	5.6K	5%	1/6W
R717	1-249-419-11	CARBON	1.5K	5%	1/6W
R718	1-249-421-11	CARBON	2.2K	5%	1/6W
R719	1-249-425-11	CARBON	4.7K	5%	1/6W
R720	1-249-431-11	CARBON	15K	5%	1/6W
R721	1-247-849-00	CARBON	5.6K	5%	1/6W
R722	1-249-419-11	CARBON	1.5K	5%	1/6W
R723	1-249-421-11	CARBON	2.2K	5%	1/6W
R724	1-249-425-11	CARBON	4.7K	5%	1/6W
R725	1-249-431-11	CARBON	15K	5%	1/6W
R726	1-247-849-00	CARBON	5.6K	5%	1/6W
R727	1-249-419-11	CARBON	1.5K	5%	1/6W
R728	1-249-421-11	CARBON	2.2K	5%	1/6W
R729	1-249-417-11	CARBON	1K	5%	1/6W
R730	1-215-452-00	CARBON	20K	5%	1/6W
R731	1-249-429-11	CARBON	10K	5%	1/6W
R732	1-249-417-11	CARBON	1K	5%	1/6W
R733	1-215-452-00	CARBON	20K	5%	1/6W
R734	1-249-429-11	CARBON	10K	5%	1/6W
R735	1-249-417-11	CARBON	1K	5%	1/6W
R736	1-215-452-00	CARBON	20K	5%	1/6W
R738	1-249-405-11	CARBON	100	5%	1/6W
R739	1-249-433-11	CARBON	22K	5%	1/6W
R740	1-249-433-11	CARBON	22K	5%	1/6W
R741	1-249-393-11	CARBON	10	5%	1/6W
R742	1-249-429-11	CARBON	10K	5%	1/6W
R743	1-249-417-11	CARBON	1K	5%	1/6W
R744	1-215-452-00	CARBON	20K	5%	1/6W
R745	1-215-452-00	CARBON	20K	5%	1/6W
R746	1-249-403-11	CARBON	68	5%	1/6W
R747	1-249-433-11	CARBON	22K	5%	1/6W
R748	1-249-433-11	CARBON	22K	5%	1/6W
R749	1-249-433-11	CARBON	22K	5%	1/6W
R750	1-215-493-00	CARBON	1M	5%	1/6W
R901	1-249-417-11	CARBON	1K	5%	1/6W

ELECTRICAL PARTS

Ref.No.	Part No.	Description			
R902	1-247-899-00	CARBON	680K	5%	1/6W
R903	1-249-429-11	CARBON	10K	5%	1/6W
R1001	1-249-441-11	CARBON	100K	5%	1/6W
R1002	1-249-441-11	CARBON	100K	5%	1/6W
R1003	1-249-429-11	CARBON	10K	5%	1/6W
R1004	1-249-429-11	CARBON	10K	5%	1/6W
R1005	1-249-429-11	CARBON	10K	5%	1/6W
R1006	1-249-433-11	CARBON	22K	5%	1/6W
R1007	1-249-441-11	CARBON	100K	5%	1/6W
R1008	1-249-413-11	CARBON	470	5%	1/6W
R1009	1-249-417-11	CARBON	1K	5%	1/6W
R1010	1-249-419-11	CARBON	1.5K	5%	1/6W
R1011	1-249-417-11	CARBON	1K	5%	1/6W
R1012	1-249-417-11	CARBON	1K	5%	1/6W
R1013	1-249-429-11	CARBON	10K	5%	1/6W
R1014	1-249-441-11	CARBON	100K	5%	1/6W
R1015	1-247-887-00	CARBON	220K	5%	1/6W
R1016	1-249-429-11	CARBON	10K	5%	1/6W
R1017	1-249-441-11	CARBON	100K	5%	1/6W
R1018	1-247-887-00	CARBON	220K	5%	1/6W
R1019	1-249-441-11	CARBON	100K	5%	1/6W
R1020	1-249-441-11	CARBON	100K	5%	1/6W
R1021	1-249-417-11	CARBON	1K	5%	1/6W
R1022	1-249-441-11	CARBON	100K	5%	1/6W
R1023	1-249-417-11	CARBON	1K	5%	1/6W
R1024	1-249-441-11	CARBON	100K	5%	1/6W
R1025	1-249-435-11	CARBON	33K	5%	1/6W
R1026	1-249-441-11	CARBON	100K	5%	1/6W
R1027	1-249-429-11	CARBON	10K	5%	1/6W
RV301	1-230-997-21	(EXCEPT C5S)...RES, VAR, CARBON 20K/20K (HEADPHONES LEVEL)			
RV501	1-237-194-11	RES, ADJ, CARBON 20K			
RV502	1-228-993-00	RES, ADJ, METAL GLAZE 4.7K			
RV503	1-237-194-11	RES, ADJ, CARBON 20K			
RV504	1-237-194-11	RES, ADJ, CARBON 20K			
RV505	1-228-990-00	RES, ADJ, METAL GLAZE 1K			
RV506	1-237-195-11	RES, ADJ, CARBON 50K			
RV507	1-237-195-11	RES, ADJ, CARBON 50K			

ELECTRICAL PARTS

Ref.No.	Part No.	Description
S1	1-571-026-11	SWITCH (ARM MOO VED)
S10	1-570-822-11	SWITCH, LEAF (LIMIT)
S002	1-552-809-00	(C5F)...SWITCH, SLIDE (TIMER)
S301	1-570-103-21	SWITCH, PUSH (1 KEY)(POWER)
S701	1-570-876-11	SWITCH, KEY BOARD (1)
S702	1-570-876-11	SWITCH, KEY BOARD (2)
S703	1-570-876-11	SWITCH, KEY BOARD (3)
S704	1-570-876-11	SWITCH, KEY BOARD (4)
S705	1-570-876-11	SWITCH, KEY BOARD (5)
S706	1-570-876-11	SWITCH, KEY BOARD (■)
S707	1-570-876-11	SWITCH, KEY BOARD (■)
S708	1-570-876-11	SWITCH, KEY BOARD (◀)
S709	1-570-876-11	SWITCH, KEY BOARD (▶▶)
S710	1-570-876-11	SWITCH, KEY BOARD (▷)
S711	1-570-876-11	SWITCH, KEY BOARD (◀◀)
S712	1-570-876-11	SWITCH, KEY BOARD (▷▷)
S713	1-570-876-11	SWITCH, KEY BOARD (CHECK)
S714	1-570-876-11	SWITCH, KEY BOARD (CLEAR)
S715	1-570-876-11	SWITCH, KEY BOARD (PROGRAM)
S716	1-570-876-11	SWITCH, KEY BOARD (SHUFFLE)
S717	1-570-876-11	SWITCH, KEY BOARD (REPEAT)
S718	1-570-876-11	SWITCH, KEY BOARD (TIME)
S719	1-570-876-11	SWITCH, KEY BOARD (OPEN/CLOSE)
S720	1-570-876-11	SWITCH, KEY BOARD (DISK SKIP)
S721	1-571-027-11	SWITCH, PUSH (3 KEY)
T301 A	1-448-842-11	(US,Canadian)...TRANSFORMER, POWER
T301 A	1-448-843-11	(AEP).....TRANSFORMER, POWER
T301 A	1-448-844-11	(E).....TRANSFORMER, POWER
TP1	*1-564-507-11	PLUG, CONNECTOR 4P
X501	1-567-692-21	VIBRATOR, CRYSTAL (8.4672MHZ)
X701	1-567-819-21	VIBRATOR, CERAMIC (4.00MHZ)
X702	1-567-818-21	VIBRATOR, CERAMIC (3.58MHZ)
YS1 A	1-570-307-11	(E)...VOLTAGE SELECTOR

ACCESSORY & PACKING MATERIAL

Part No.	Description
1-463-796-11	(EXCEPT C5S)...REMOTE COMMANDER (RM-05)
1-558-233-11	(EXCEPT C5S)...CORD (WITH CONNECTOR)
1-558-787-11	(EXCEPT C5S)...CORD, CONNECTION (SIRCS) 4P
3-701-630-00	BAG, POLYETHYLENE
3-703-390-01	(C5F:US,C57)...INSTRUCTION
3-703-680-00	LABEL, CAUTION, SUB, NEW UL
3-703-713-41	(EXCEPT C5S)...STICKER, SONY SYMBOL (10)
*3-704-217-01	LABEL
3-764-766-01	INSTRUCTION (MICRO COMPUTER 2)
3-765-967-11	(C5F:Canadian,AEP,E)...MANUAL, INSTRUCTION
3-765-967-21	(C5F:US).....MANUAL, INSTRUCTION
3-765-967-41	(C5F:AEP).....MANUAL, INSTRUCTION
3-765-967-51	(C57).....MANUAL, INSTRUCTION
3-795-629-11	(AEP)...INSTRUCTION (DEMCO)
4-880-211-00	SHEET, PROTECTION
4-919-467-11	SHEET, THROW
4-919-469-01	(C5F:US).....INDIVIDUAL CARTON
4-919-469-11	(C5F:Canadian,AEP,E)...INDIVIDUAL CARTON
4-919-469-21	(C57).....INDIVIDUAL CARTON
4-919-471-01	(EXCEPT C5S)...CUSHION (LEFT)
4-919-472-01	(EXCEPT C5S)...CUSHION (RIGHT)
4-919-481-01	PROTECTOR
*4-919-488-01	LABEL, CAUTION
X-4919-416-1	(EXCEPT C5S)...HOLDER ASSY, CD BOOKLET

The components identified by shading and mark **A** are critical for safety. Replace only with part number specified.

Les composants identifiés par une trame et une marque **A** sont critiques pour la sécurité. Ne les remplacer que par une pièce portant le numéro spécifié.

SECTION 8 TROUBLESHOOTING

The following checks will assist in the correction of most problems which you may encounter with your unit. Should any problem persist after you have made these checks, consult your nearest Sony service facility. Before going through the check list below, first refer back to the connection and operating procedures.

TROUBLE	CAUSES	REMEDY
No audio from one or both channels	Incorrect operation of the amplifier	Operate correctly.
	Loose connection	Connect the cords firmly.
Play does not begin.	No disc in the disc compartment	Put disc(s) in the compartment.
	The II button has been pressed.	Press the II button again or press the ▶ button to release pause.
	No disc in the front position with the disc compartment open. (SINGLE play)	Rotate the disc compartment so that the disc comes in front.
	Moisture condensation	Leave the player turned on for about an hour.
	The disc is set upside down.	Set the disc with the label side up.
	The disc is incorrectly set.	Set the disc correctly.
Discs cannot be played continuously.	The disc is extremely dirty.	Clean the disc.
	The SINGLE button is depressed.	Depress the MULTI button.
Play stops at each end of selections.	The AUTO PAUSE switch is depressed.	Depress the AUTO PAUSE switch again to release the auto pause function.
Play does not begin at time set by timer. (The unit power is turned on.)	The AUTO PAUSE switch has been pressed.	Release auto pause before setting the timer.
Remote commander does not operate the unit.	The batteries are exhausted.	Replace both batteries.
	The remote commander is not pointed at the remote sensor.	Point the remote commander to the remote sensor.
	There is an obstacle between the remote commander and the unit.	Remove the obstacle.
Any operation is not possible.	The internal control program may not run correctly.	Turn OFF the power and turn it ON again.

Sony Corporation
Audio Group

CDP-C5F/C5S/ C57

SONY[®] SERVICE MANUAL

SUPPLEMENT-1

File this supplement with the Service Manual.

Since PC board patterns in this model were changed several times, some parts have been added or changed of their values and also the suffix of IC701 has been changed to new one.

For the above reason the latest schematic and mounting diagrams are issued with this supplement.

1. Suffix of IC701

Model	Countries	Serial number	Description
CDP-C5F	US	800,001-808,100 808,101-809,800 809,801-	M50941-411SP M50941-412SP M50941-413SP
	Canadian AEP E	001-	M50941-413SP
CDP-C5S	US	0,001- 2,500 2,501- 3,000 3,001-	M50941-411SP M50941-412SP M50941-413SP
CDP-C57	US	800,001-802,000 802,001-	M50941-411SP M50941-413SP

2. Changes of board suffix with serial numbers

Model	Countries	Serial number	Suffix
CDP-C5F	US	800,201-806,000 806,001-	-12 -13
	Canadian AEP E	001-	-13
CDP-C5S	US	001-802,500 2,501-	-12 -13
CDP-C57	US	800,001-802,000 802,001-	-12 -13

3. Parts existence list on RMS BOARD

Description IC701	RMS board	C562	D319	R590
M50941-411SP	○	10MF 50V	1SS132	100K
M50941-412SP	○	10MF 50V	1SS132	100K
M50941-413SP	X	JW	X	X

*US Model
Canadian Model
AEP Model
E Model
CDP-C5F*

*US Model
CDP-C5S*

*US Model
CDP-C57*

4. Parts existence list on MAIN BOARD

Ref. No.	Part No.	Description	Suffix
C108, 208	1-124-187-11	NONPOLA 22MF 20% 50V	-12
C110	1-124-282-00	ELECT 22MF 20% 25V	-12
C112, 212	1-162-290-11	(AEP).....CERAMIC 470PF 10% 50V	-14 to -15
C209	1-123-875-91	(EXCEPT C5S)..ELECT 10MF 20% 50V	-12
C316	1-123-875-91	ELECT 10MF 20% 50V	-12
C562	1-124-927-11	ELECT 4.7MF 20% 50V	-12
C568	1-162-298-00	CERAMIC 0.0047MF	-12(conductor side)
C569	1-162-596-00	CERAMIC 0.022MF	-12(conductor side)
C570	1-110-199-00	FILM 0.0022MF	-13 to -15
C571	1-161-494-00	CERAMIC 0.022MF 25V	-12
C574	1-124-181-51	NONPOLA 0.47MF	-12
C710			
L502	1-408-383-00	MICRO INDUCTOR 220UH	-13 to -15
L503	1-408-188-11	(EXCEPT E)...MICRO INDUCTOR 100MH	-14 to -15
Q521	8-729-806-28	TRANSISTOR 2SC3402	-13 to -15
Q522, 523, 524	8-729-116-02	TRANSISTOR DTC114ES	-13 to -15
Q525, 526	8-729-101-34	TRANSISTOR 2SC2785	-13 to -15
Q527	8-729-900-65	TRANSISTOR DTA114ES	-14
Q528	8-729-900-89	TRANSISTOR DTC144ES	-14
R000			
R525	1-249-429-11	CARBON 10K 5% 1/6W	-12
R558	1-249-433-11	CARBON 22K 5% 1/6W	-14 to -15
R600, 601	1-249-429-11	CARBON 10K 5% 1/6W	-14 to -15
R602	1-249-437-11	CARBON 47K 1/6W	-14 to -15
R603	1-249-405-11	CARBON 100 1/6W	-14 to -15
RV503, 504	1-228-995-00	RES, ADJ, CARBON 22K	-13 to -15
RV506, 507	1-228-996-00	RES, ADJ, CARBON 47K	-13 to -15

5. Parts existence list on JACK BOARD

Ref. No.	Part No.	Description	Suffix
C705	1-162-596-00	CERAMIC 0.022MF	-12(conductor side)
C711	1-162-596-00	CERAMIC 0.022MF	-14 to -15

6. Parts existence list on INDICATION BOARD

Ref. No.	Part No.	Description	Suffix
906	A-4655-054-A	(AEP)...MOUNTED PCB, INDICATION	-14 to -15

7. Parts existence list on POWER TRANSFORMER BOARD

Ref No.	Part No.	Description	Suffix
C001	1-161-741-00	(E).....CERAMIC 0.001MF 10% 400V	-14 to -15
C002-004	1-161-741-00	(AEP, UK, E).. CERAMIC 0.001MF 10% 400V	-14 to -15

8. Parts existence list on OTHERS BOARD

Ref. No.	Part No.	Description	Suffix
C574	1-124-181-51	NONPOLA 0.47MF	-12
C901	_____	_____	_____
C1001-1011	_____	_____	_____
D901, 902	_____	_____	_____
D1001-1015	_____	_____	_____
IC1001-1009	_____	_____	_____
L701	_____	_____	_____
Q901	_____	_____	_____
Q1001-1005	_____	_____	_____
R901, 903	_____	_____	_____
R1001-1027	_____	_____	_____

9. Parts existence list on RF BOARD

Ref. No.	Part No.	Description	Suffix
RV501	1-228-995-00	RES, ADJ, CARBON 22K	-14 to -15

10. Parts existence list on DISPLAY BOARD

Ref. No.	Part No.	Description	Suffix
IC703	8-741-138-70	(EXCEPT C5S)...IC BX1387	-13 to -15
Q701	8-729-205-02	TRANSISTOR 2SB810	-15
Q702	8-729-205-02	TRANSISTOR 2SB810	-15
Q708	8-729-900-36	(EXCEPT C5S)...DTC124ES	-15

● Q522, 523, 524

[MAIN BOARD]

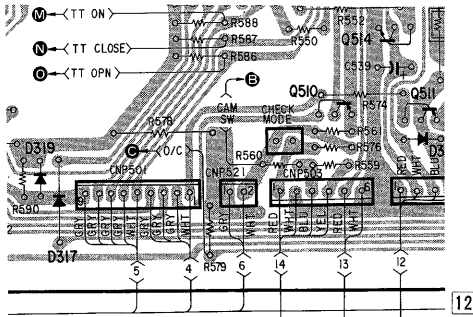

Board suffix -12
↓
Changed portions to the suffix -13 to -15

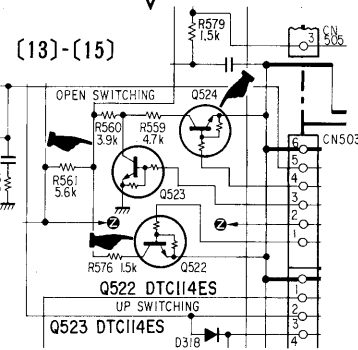
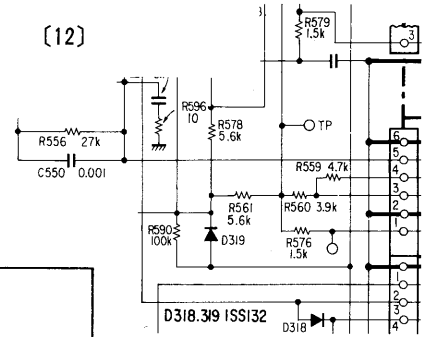
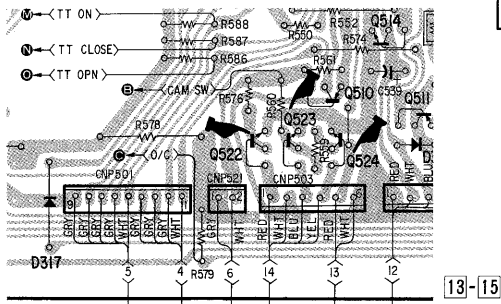

- Q525, 526, R600, 601 (-13)
- Q527, 528, R602, 603 (-14)

[MAIN BOARD]

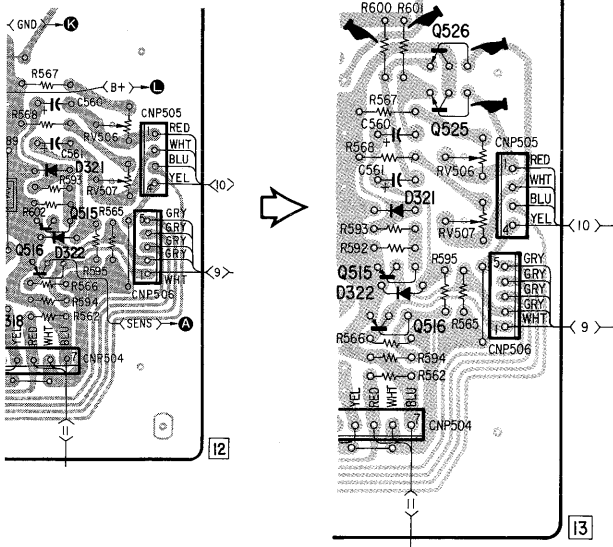

Board suffix -12
↓
Changed portions to the suffix -13

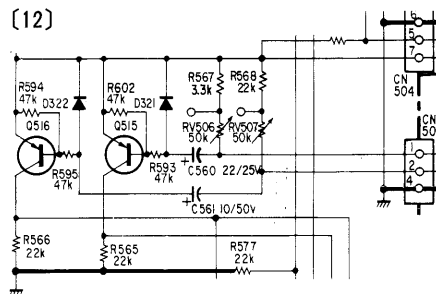

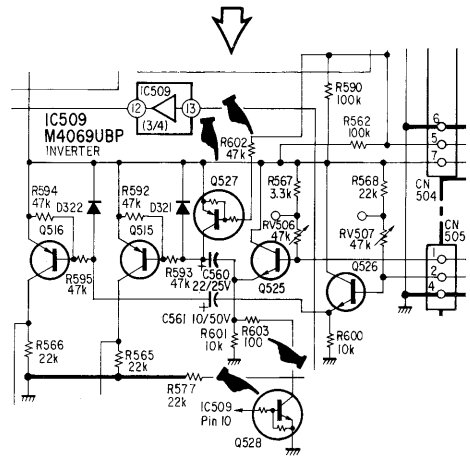
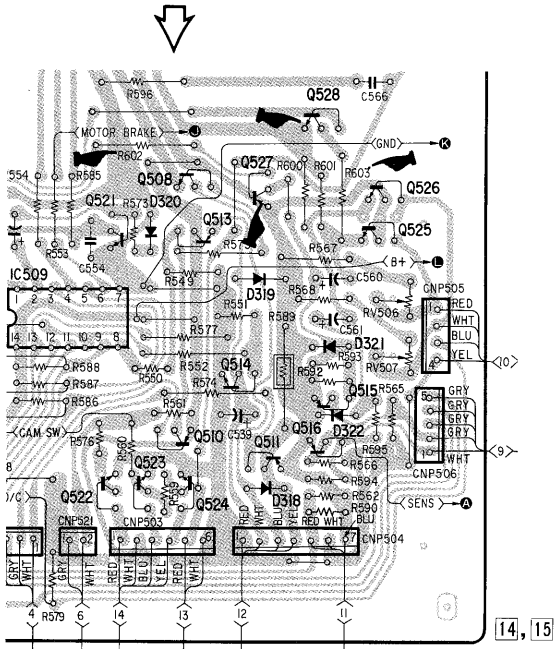

Board suffix -12
 ↓
 Changed portions to the suffix -14 to -15

● C705

[JACK BOARD]

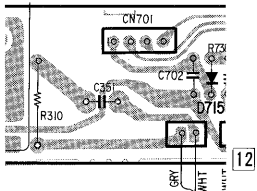

Board suffix -12
 ↓
 Changed portions to the suffix -13 to -15

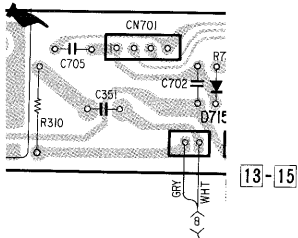

[12]

[JACK BOARD(2/3)]

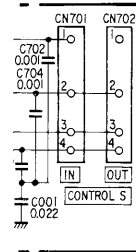

[JACK BOARD(2/3)]

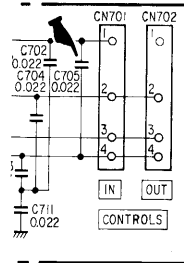

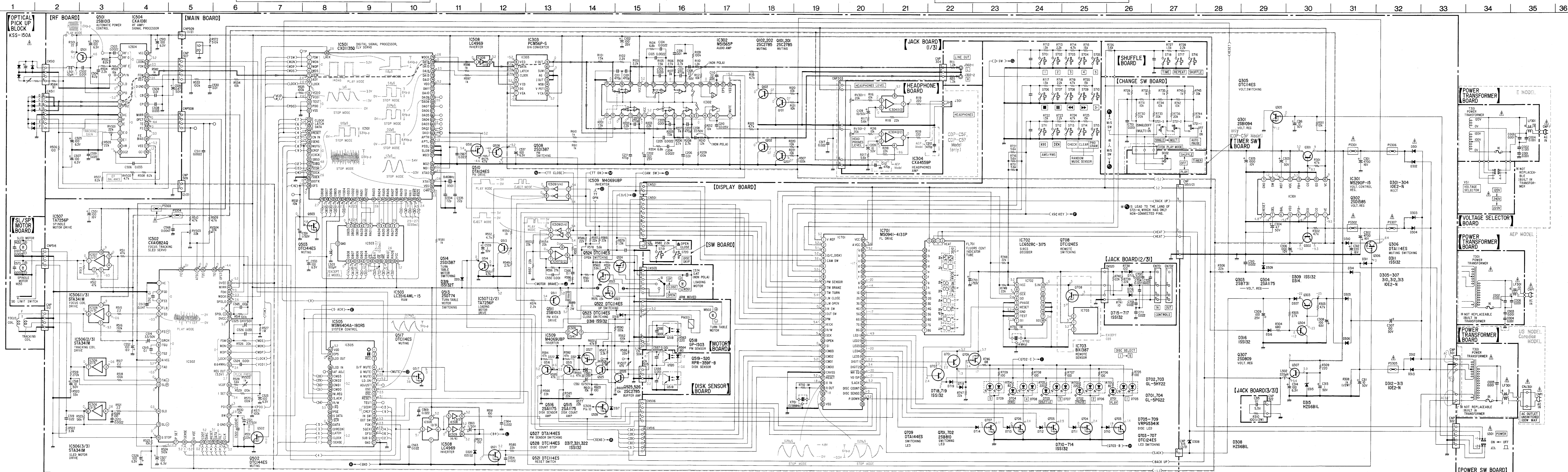

- Note on Schematic Diagram:**
- All capacitors are in μF unless otherwise noted. pF: μF 50WV or less are not indicated except for electrolytics and tantalums.
 - All resistors are in Ω and $1/4\text{W}$ or less unless otherwise specified.
 - **[RNF]**: nonflammable resistor.
 - **[L-CH]**: L-CH Signal path.
 - **[R-CH]**: R-CH Signal path.
 - **[B+]**: B+ bus.
 - **[B-]**: B- bus.
 - **[ADJ]**: adjustment for repair.
 - Voltages are dc with respect to ground unless otherwise noted.
 - Readings are taken under no-signal conditions with a VOM (50 $\text{k}\Omega/\text{V}$).
 - no mark: STOP
 - Voltage variations may be noted due to normal production tolerances.
 - Waveforms are taken to ground in STOP mode by using oscilloscope.
 - Voltage variations may be noted due to normal production tolerances.
 - Switches:

Ref. No.	Switch	Position
S1	ARM MOVED	UP
S002	TIMER	OFF
S10	LIMIT	ON
S301	POWER	OFF
S701	1	OFF
S702	2	OFF
S703	3	OFF
S704	4	OFF
S705	5	OFF
S706	■	OFF
S707	■	OFF
S708	■	OFF
S709	▶▶	OFF
S710	▶▶	OFF
S711	◀◀	OFF
S712	◀◀	OFF
S713	CHECK CLEAR	OFF
S714	CLEAR	OFF
S715	PROGLAM	OFF
S716	SHUFFLE	OFF
S717	SHUFFLE	OFF
S718	REPEAT	OFF
S719	TIME	OFF
S720	OPEN/CLOSE	CLOSE
S721	DISK SKIP	OFF
S722	DISK PLAY MODE	OFF
VS1	E model: VOLTAGE SELECTOR	120V

Note:
The components identified by mark **A** or dotted line with mark **A** are critical for safety. Replace only with part number specified.

Note:
Les composants identifiés par une marque **A** ou une ligne pointillée avec la marque **A** sont critiques pour la sécurité. Ne les remplacer que par une pièce portant le numéro spécifié.

Semiconductor Locations

[MAIN BOARD]

Ref. No.	Location	Ref. No.	Location	Ref. No.	Location
D301	B-21	D713	J-11	O306	C-20
D302	B-21	D714	J-11	O307	D-21
D303	B-21	D715	F-11	O501	F-24
D304	B-22	D716	F-12	O502	E-19
D305	C-21	D717	F-12	O503	D-17
D306	C-21	D718	K-13	O508	H-20
D307	C-20	D719	K-13	O510	J-20
D308	D-22			O511	J-21
D309	D-19	IC301	C-20	O513	I-20
D310	C-20	IC302	C-17	O514	J-21
D311	C-20	IC303	D-16	O515	J-21
D312	C-22	IC304	B-14	O516	J-21
D313	C-22	IC501	F-17	O517	D-18
D314	D-20	IC502	E-20	O518	F-27
D315	D-21	IC503	E-16	O519	J-26
D316	B-19	IC504	E-24	O520	J-27
D317	K-19	IC505	I-16	O521	I-20
D318	J-21	IC506	E-21	O522	J-20
D319	J-18	IC507	E-21	O523	J-20
D320	I-20	IC508	H-16	O524	J-20
D321	I-21	IC509	I-19	O525	I-22
D322	J-21	IC701	J-8	O526	H-22
D701	K-13	IC702	J-9	O527	H-21
D702	K-12	IC703	J-14	O528	H-21
D703	K-11			Q701	K-11
D704	K-10	Q101	B-16	Q702	K-11
D705	J-13	Q102	B-16	Q703	J-13
D706	J-12	Q201	B-17	Q704	J-13
D707	J-12	Q202	B-17	Q705	J-12
D708	J-11	Q301	B-19	Q706	J-11
D709	J-10	Q302	B-19	Q707	J-11
D710	J-13	Q303	B-20	Q708	K-14
D711	J-12	Q304	B-20	Q709	K-13
D712	J-12	Q305	B-20		

Note:
• **○**: parts extracted from the component side.
• **■**: part mounted on the conductor side.

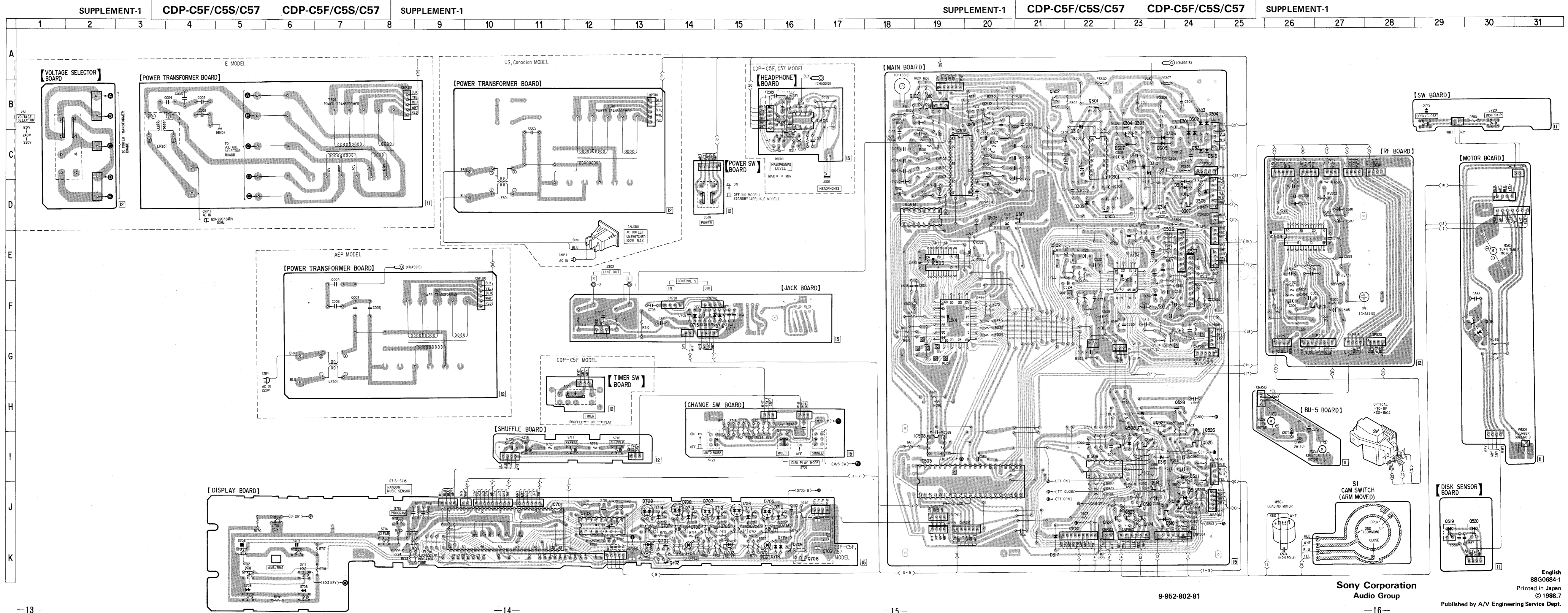

CDP-C5F/C5S/C57

SONY[®] SERVICE MANUAL

US Model
Canadian Model
AEP Model
E Model
CDP-C5F

US Model
CDP-C5S

US Model
CDP-C57

SUPPLEMENT-2

File this supplement with the service manual.

Removal of Main Board

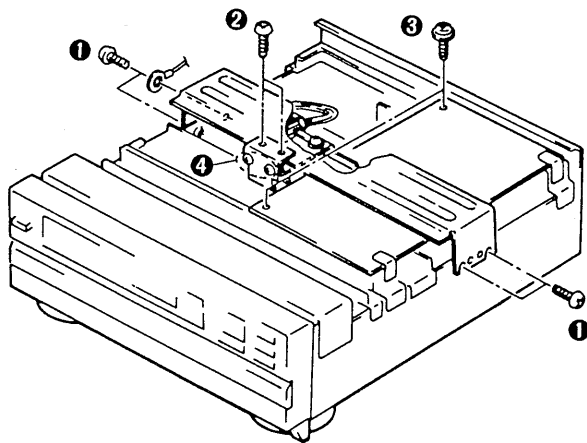

Fig. 1

1. Remove four screws which fasten both sides of reinforcement. (L, center part of chassis.) (Figure 1-**1**)

2. Remove two screws which fasten the reinforcement (SB) to the reinforcement. (Figure 1-**2**)

Note-1 Do not remove the two screws of figure 1-**4** since the installation location might be shifted.

Note-2 When removing wire from wire clamp on the chucking block reinforcement, it is advised that the location on the wire where the wire clamp had been since the pull-around on the wire will be returned to the former position.

* This is the procedure to remove the reinforcement.

3. Remove two screws (Figure 1-**3**) which fasten the main board.

4. Remove the wire between the front panel and the main board out of the two purse locks.

5. Remove headphone lead (gray) which is connector-connected on the main board.

* This is the procedure to raise the PC board hinge on the right side of the main board as the fulcrum.

• This part removal enables to adjust RF board and check the optical block.

Removal of Front Panel ass'y

6. Remove three screws which fasten the front panel ass'y to the reinforcement.

7. Remove a screw which fastens the front panel ass'y to the bottom of the chassis ass'y.

8. Turn the power supply on and press the OPEN/CLOSE button to take the disc table out.

Note) See "When disc table does not open even if OPEN/CLOSE button is pressed" on page 8 of the service manual when the disc table does not come out in spite of turning on the power supply.

9. Remove the hexagonal-socket bolt (2m/m) which fastens the station cover ass'y to the disc table to remove the station cover ass'y.

10. Remove the three links that fasten the front panel ass'y to the bottom of the chassis ass'y and slide the front panel to the front side to be removed.

Removal of Disc Table

11. Remove four screws which fasten both sides of the reinforcement (front panel side) to remove the reinforcement.
12. Remove the four screws which fasten both sides of the station base and PC board bracket (front panel side).
13. Remove the main board from the PC board hinge which fastens the main board to PC board bracket (front panel side).
* This procedure removes the station base and PC board bracket, however, headphone leads do not have to be removed if they open out to the left side since each part has headphone lead (gray).
14. Push the disc table to the end.
15. Remove the screws with washer which fasten the disc table which can be seen from the two squared holes on the right side of the chassis ass'y to the guide bar retainer.
16. Remove the left side of the disc table out of the guide (rear) moving the disc table from left to right and raise it to remove the disc table.
* This is the procedure for taking apart. In case of changing the optical block, follow the steps up to 16.

PRECAUTION IN ASSEMBLING

Following the opposite procedure assembles the parts, however, there are some precautions.

Station Base

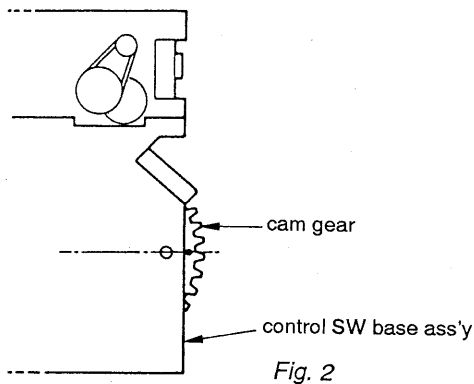

1. Set the ● mark of the cam gear and the hole on the control SW base ass'y as shown on figure 2.
2. Put down the guide bar retainer at the squared hole side on the chassis ass'y.
3. Mesh the left slide part of the station base (figure 3-①) with the guide (figure 3-②).
4. Put the boss of the station base into the ditch of “※” of the figure 3-④ (lock lever), seeing through from the squared hole on the chassis ass'y on figure 3-③.
5. After putting the boss of figure 4-② into the hole of figure 4-① to locate, screw the disc table to the guide bar retainer.

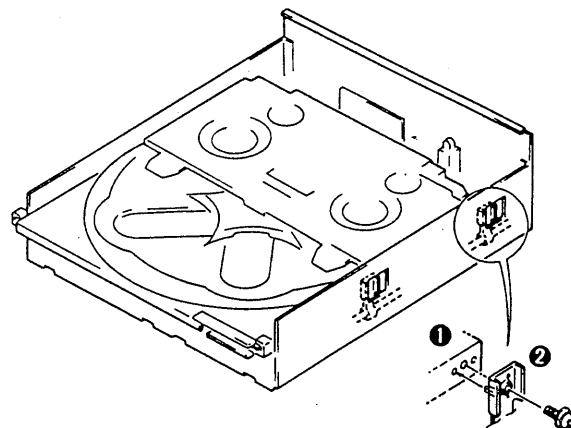
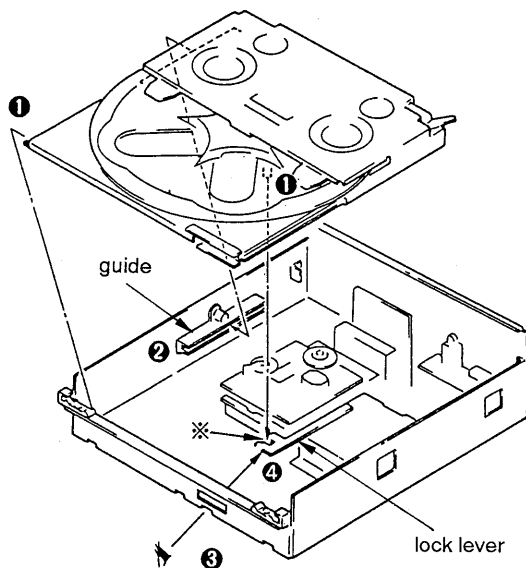

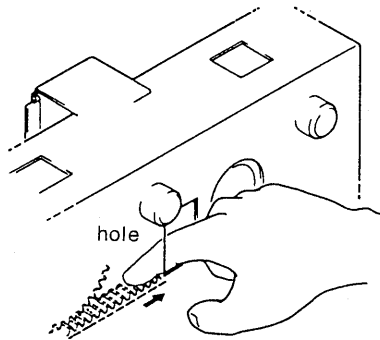
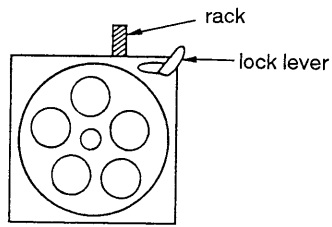

Fig. 5

6. The rack of the station base should be unlocked to be put behind.

Note) Since the disc table does not come out by setting the disc table with this procedure, remove the chassis cover attached to the bottom of chassis ass'y and stick a finger into the squared hole on figure 5 to move the rack behind and remove the mesh with the cam gear to re-mesh with it. Then the disc table will come out.

* Perform the same procedure when the gear meshes and the disc table does not come out.

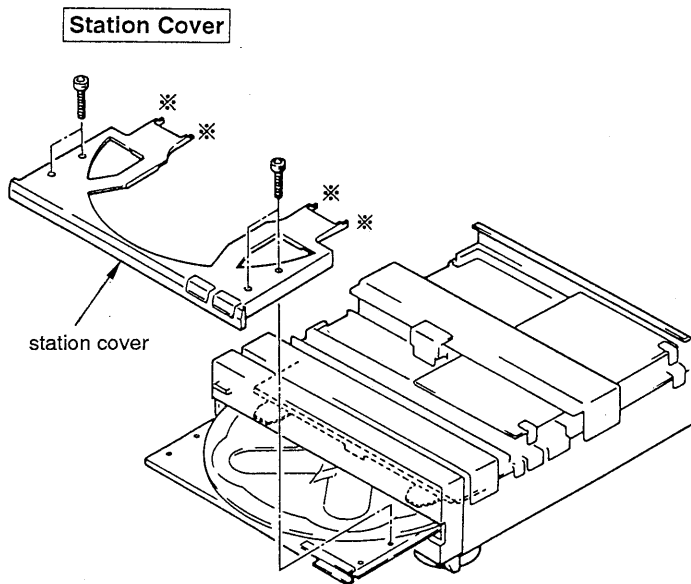

Fig. 6

1. Take out the disc table.
2. Put the station cover on the disc table.
3. Slide the station cover further to the end inserting the four * marks on figure 6 under the chucking bracket.
4. Hang the rear part of the cover front on the disc table as figure 7.
5. Screw four hexagonal-socket bolts (2m/m)

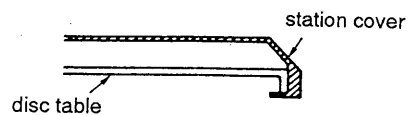

Fig. 7

Precaution in Setting Each of Four Reinforcements

Fasten the screws after pressing the reinforcement completely on the guide of the chassis ass'y or the stopper to set the location.

