

CDP-C75ES/C85ES/C705

SERVICE MANUAL

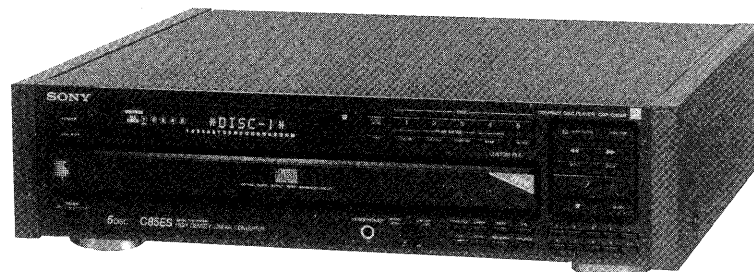

Photo : CDP-C85ES

US Model
Canadian Model
CDP-C75ES

US Model
E Model
CDP-C85ES

US Model
Canadian Model
AEP Model
E Model
Australian Model
CDP-C705

SPECIFICATIONS

Compact Disc Player

Frequency response	2 Hz - 20 kHz (± 0.3 dB)
Signal to noise ratio	More than 105 dB
Dynamic range	More than 98 dB (CDP-C75ES/C85ES) More than 95 dB (CDP-C705)
Harmonic distortion	Less than 0.0025 % (CDP-C85ES) Less than 0.003 % (CDP-C75ES) Less than 0.0035 % (CDP-C705)
Channel separation	More than 105 dB (CDP-C75ES/C85ES) More than 100 dB (CDP-C705)

Outputs

LINE OUT (FIXED) (phono jacks)	Output level 2 V (at 50 kilohms) Load impedance over 10 kilohms
LINE OUT (VARIABLE) (phono jacks)	Output level max 2 V (at 50 kilohms) Load impedance over 10 kilohms
DIGITAL OUT (OPTICAL) (optical output connector)	Wave length 660 nm Output level -18 dBm
HEADPHONES (stereo phone jack)	Output level max. 15 mW Load impedance 32 ohms

General

Power requirements	AC 120 V, 60 Hz
Power consumption	13 W

Dimensions (w/h/d)	Approx. 470 × 125 × 385 mm (18 ³ / ₈ × 5 × 15 ¹ / ₄ inches) (CDP-C85ES) Approx. 430 × 125 × 385 mm (17 × 5 × 15 ¹ / ₄ inches) (CDP-C75ES / C705)
Weight	Including projecting parts and controls Approx. 8 kg (17 lbs 11 oz), net (CDP-C85ES) Approx. 7 kg (15 lbs 7 oz), net (CDP-C75ES) Approx. 6kg (13lbs 4oz), net (CDP-C705)
Remote Commander RM-D706	
Remote control system	Infrared control
Power requirements	3 V DC with two size AA batteries (IEC designation R6)
Dimensions	62 × 20 × 175 mm (w/h/d) (2 ¹ / ₂ × 1 ¹ / ₁₆ × 7 inches)
Weight	126 g (4.5 oz) including batteries

Supplied Accessories

Connecting cord	(2 phono plugs ↔ 2 phono plugs) (1)
Remote commander	(1)
Size AA batteries	(2)
Screws	(4) (CDP-C85ES only)

Design and specifications subject to change without notice.



COMPACT DISC PLAYER
SONY®

TABLE OF CONTENTS

<u>Section</u>	<u>Title</u>	<u>Page</u>
Specifications	1
1. GENERAL		
Location of Controls	5
2. ADJUSTMENTS		
2-1. Mechanical Adjustments	6
2-2. Before Adjustments	6
2-3. Service Mode	7
2-4. Electrical Adjustments	8
3. DIAGRAMS		
3-1. Semiconductor Lead Layouts	10
3-2. Circuit Boards Location	10
3-3. Block Diagram	11
3-4. IC Block Diagrams	14
3-5. Printed Wiring Boards - Main Board -	16
3-6. Schematic Diagram	21
3-7. Printed Wiring Boards		
- Display Board -	26
4. EXPLODED VIEWS		
		31
5. ELECTRICAL PARTS LIST		
		35

Note on the Transit Key

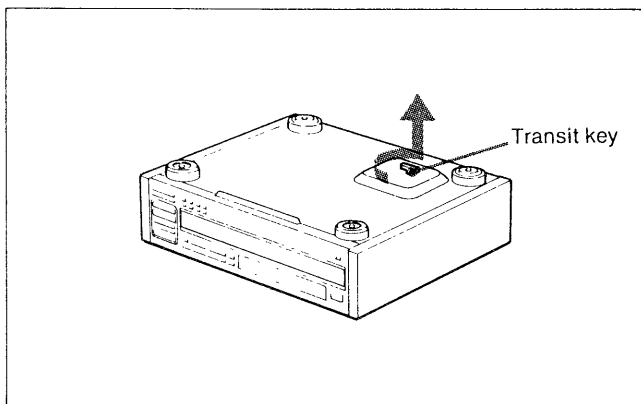

The transit key on the bottom exterior of the unit protects the optical system against shock during transportation. Before operating the CD player, be sure to remove the key by following the instructions on the label, and store it in a safe place.

When transporting the unit, replace the key in its original hole and lock it in place.

Adjusting Operating Voltage

For the customers of the model equipped with the voltage selector (E model)
 Check that the voltage selector is set to the local power line voltage. If not, set the selector to the correct position before connecting AC power cord to a wall outlet.

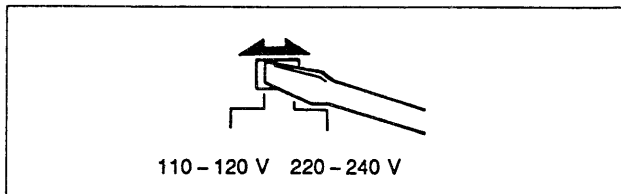

SAFETY-RELATED COMPONENT WARNING!!

COMPONENTS IDENTIFIED BY MARK Δ OR DOTTED LINE WITH MARK Δ ON THE SCHEMATIC DIAGRAMS AND IN THE PARTS LIST ARE CRITICAL TO SAFE OPERATION. REPLACE THESE COMPONENTS WITH SONY PARTS WHOSE PART NUMBERS APPEAR AS SHOWN IN THIS MANUAL OR IN SUPPLEMENTS PUBLISHED BY SONY.

ATTENTION AU COMPOSANT AYANT RAPPORT À LA SÉCURITÉ!

LES COMPOSANTS IDENTIFIÉS PAR UNE MARQUE Δ SUR LES DIAGRAMMES SCHÉMATIQUES ET LA LISTE DES PIÈCES SONT CRITIQUES POUR LA SÉCURITÉ DE FONCTIONNEMENT. NE REMPLACER CES COMPOSANTS QUE PAR DES PIÈCES SONY DONT LES NUMÉROS SONT DONNÉS DANS CE MANUEL OU DANS LES SUPPLÉMENTS PUBLIÉS PAR SONY.

SAFETY CHECK-OUT

After correcting the original service problem, perform the following safety check before releasing the set to the customer:

Check the antenna terminals, metal trim, "metallized" knobs, screws, and all other exposed metal parts for AC leakage. Check leakage as described below.

LEAKAGE TEST

The AC leakage from any exposed metal part to earth ground and from all exposed metal parts to any exposed metal part having a return to chassis, must not exceed 0.5 mA (500 microamperes). Leakage current can be measured by any one of three methods.

1. A commercial leakage tester, such as the Simpson 229 or RCA WT-540A. Follow the manufacturers' instructions to use these instruments.
2. A battery-operated AC milliammeter. The Data Precision 245 digital multimeter is suitable for this job.
3. Measuring the voltage drop across a resistor by means of a VOM or battery-operated AC voltmeter. The "limit" indication is 0.75 V, so analog meters must have an accurate low-voltage scale. The Simpson 250 and Sanwa SH-63Trd are examples of a passive VOM that is suitable. Nearly all battery operated digital multimeters that have a 2V AC range are suitable. (See Fig. A)

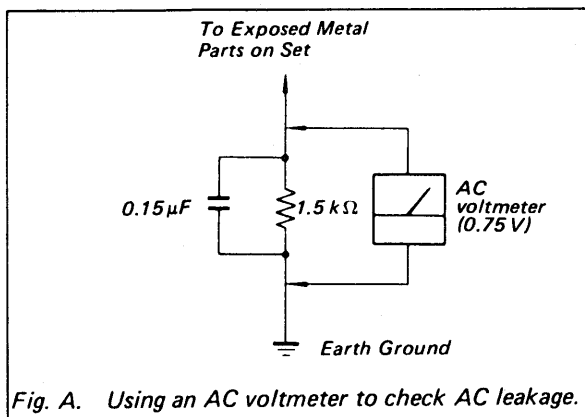
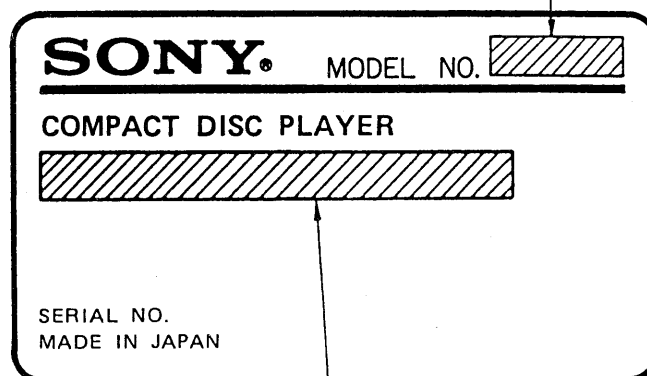

Fig. A. Using an AC voltmeter to check AC leakage.

MODEL IDENTIFICATION

— Specification Labels —

CDP - C75ES
CDP - C85ES
CDP - C705



US, Canadian model : AC 120V 60Hz 13W
AEP model : AC 220V 50/60Hz 13W
E model : AC 110 - 120, 220 - 240V 50/60Hz 13W
Australian model : AC 240V - 50/60Hz 13W

NOTES ON HANDLING THE OPTICAL PICK-UP BLOCK OR BASE UNIT

The laser diode in the optical pick-up block may suffer electrostatic breakdown because of the potential difference generated by the charged electrostatic load, etc. on clothing and the human body. During repair, pay attention to electrostatic breakdown and also use the procedure in the printed matter which is included in the repair parts. The flexible board is easily damaged and should be handled with care.

NOTES ON LASER DIODE EMISSION CHECK

The laser beam on this model is concentrated so as to be focused on the disc reflective surface by the objective lens in the optical pick-up block. Therefore, when checking the laser diode emission, observe more than 30 cm away from the objective lens.

PROTECTION OF EYES FROM LASER BEAM DURING SERVICING

This set employs a laser. Therefore, be sure to follow carefully the instructions below when servicing.

CAUTION

Use of controls or adjustments or performance of procedures other than those specified herein may result in hazardous radiation exposure.

1. Laser Diode Properties

- Material: GaAlAs
- Wavelength: 780 nm
- Emission Duration: continuous
- Laser Output: max. 44.6 μ W*

* This output is the value measured at a distance of about 200 mm from the objective lens surface on the Optical Pick-up Block.

- ### 2. During service, do not take the Optical Pick-up Block apart, and do not adjust the APC circuit. If there is a breakdown in the APC circuit (including laser diode), replace the entire Optical Pick-up Block (including APC board).

BESKYTTELSE AF ØJNE MOD LASERSTRÅLING UNDER SERVICE

I dette apparat anvendes laserlys. Derfor skal nedenstående instruktioner nøje følges under service.

Følg iøvrigt instruktionerne i servicemanualen.

ADVARSEL!!

Under service må øjnene ikke komme nær objektiv-linsen på den optiske pick-up enhed. I tilfælde af at det er nødvendigt at kontrollere udsendelsen af laserlys, skal det ske i en afstand af mere end 25 cm fra den optiske pick-up.

1. Laser-dioe data

- Materiale: GaAlAs
- Bølgelængde: 780 nm
- Udstråling: Kontinuerlig
- Laseroutput: Max. 0,4 mW*
 - * Målt i 1,6 mm afstand fra overfladen af objektiv-linsen på den optiske pick-up enhed.
- Klassifikation: Klasse IIIb.

- ### 2. Adskil aldrig den optiske pick-up enhed under service, og juster ikke APC kredsløbet (Automatic Power Control). Hvis APC kredsløbet (incl. laser-dioden) bryder ned, skal hele den optiske pick-up enhed (incl. APC printkortet) udskiftes.

LASER ADVARSEL MÆRKNING

Følgende mærkning findes indvendig i apparatet:

1. Advarsel Mærkning

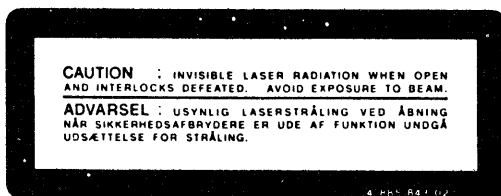

VAROITUS: Laite sisältää, laserdiodin, joka lähettää (näkyvätöntä) silmille vaarallista lasersäteilyä.

SECTION 1 GENERAL

Location of Controls

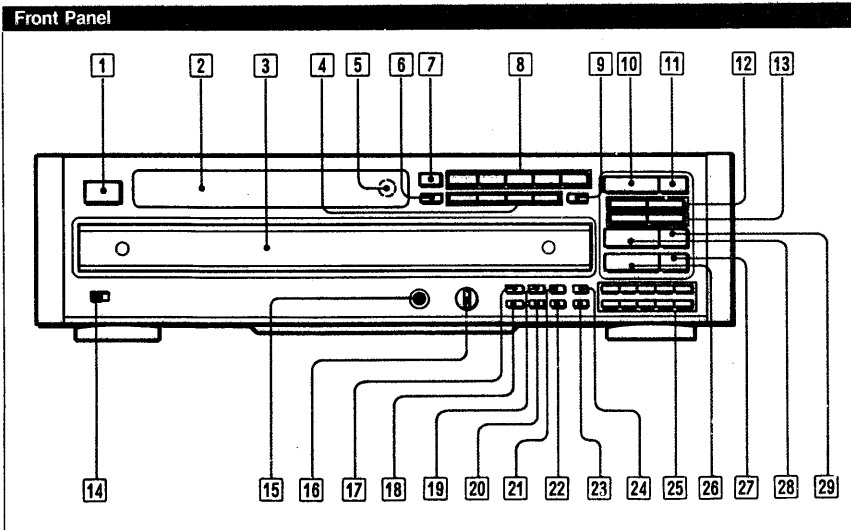

- 1 POWER switch
- 2 Display window
- 3 Disc tray
- 4 PLAY MODE buttons
CONTINUE button
SHUFFLE button
PROGRAM button
BANK button
- 5 Remote sensor
- 6 TIME/MEMO button
- 7 MUSIC SCAN button
- 8 DISC 1 - 5 buttons
- 9 REPEAT button
- 10 ▲ OPEN/CLOSE button
- 11 DISC SKIP button
- 12 ◀▶ (manual search) buttons
- 13 ◀▶▶ (AMS*) buttons

- 14 TIMER switch
- 15 HEADPHONES jack
- 16 PHONE LEVEL/LINE OUT LEVEL control
- 17 LEVEL FILE button
- 18 FILE button
- 19 CHECK button
- 20 ERASE button
- 21 CLEAR button
- 22 PEAK SEARCH button
- 23 TIME FADE button
- 24 >10 button (CDP-C85ES only)
- 25 Track buttons (CDP-C85ES only)
- 26 ■ (stop) button
- 27 FADER button
- 28 ▶ (play) button
- 29 || (pause) button

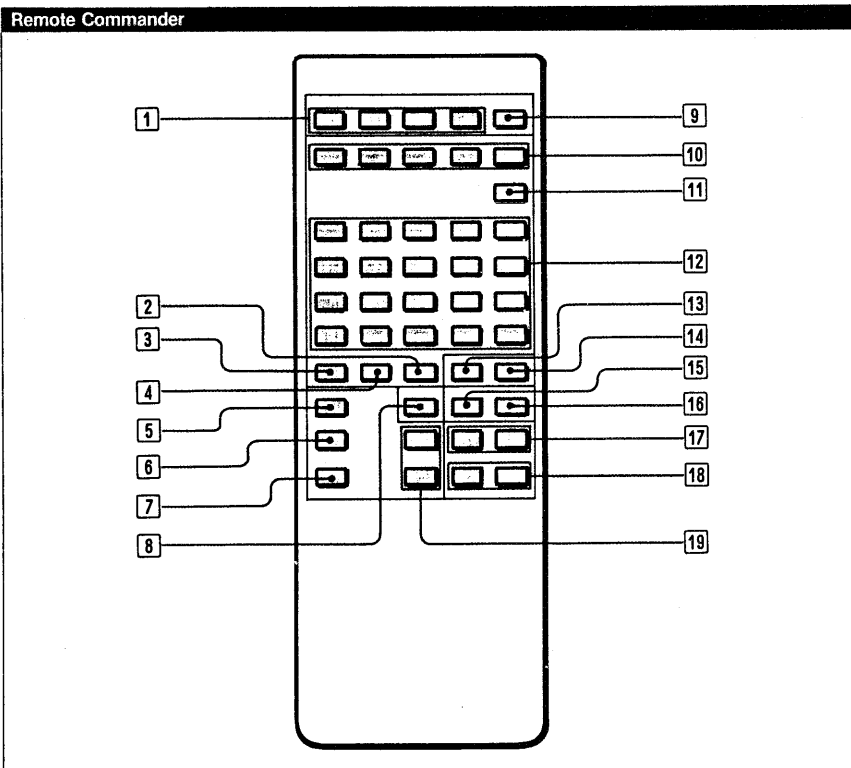

- 1 PLAY MODE buttons
CONTINUE button
SHUFFLE button
PGM (program) button
BANK button
- 2 CLEAR button
- 3 >20 button
- 4 CHECK button
- 5 ▶ (play) button
- 6 || (pause) button
- 7 ■ (stop) button
- 8 FADER button

- 9 MUSIC SCAN button
- 10 DISC 1 - 5 buttons
- 11 DISC SKIP button
- 12 TRACK buttons
- 13 FILE button
- 14 LEVEL FILE button
- 15 TIME button
- 16 REPEAT button
- 17 ◀▶▶ (AMS*) buttons
- 18 ◀▶▶ (manual search) buttons
- 19 LINE OUT VOLUME buttons

*AMS is the abbreviation of Automatic Music Sensor.

SECTION 2 ADJUSTMENTS

2-1. MECHANICAL ADJUSTMENT

Chuckling Arm Height Adjustment

This adjustment should be performed after the electrical adjustment and on replacing adjusting screw, magnet, or chucking pulley.

Procedure:

1. Set disc (YEDS-18) to the optical pick-up block. (Fig. A)
2. Adjust the bracket (press pulley) to the center of the magnet with adjusting screw. (Fig. B)

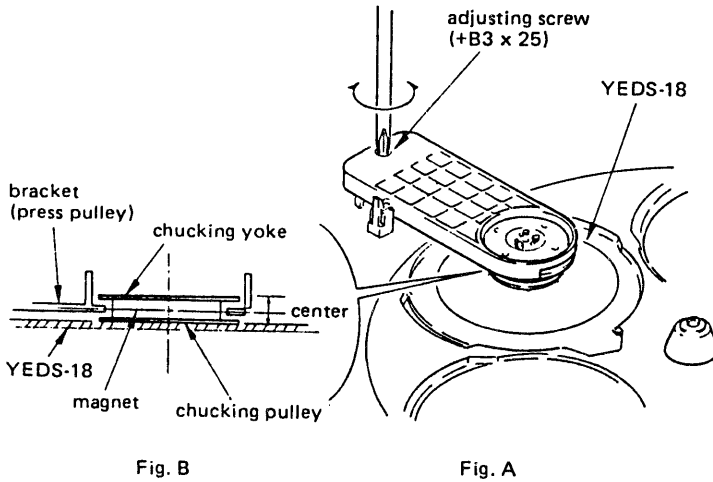

3. Remove the disc table assembly.

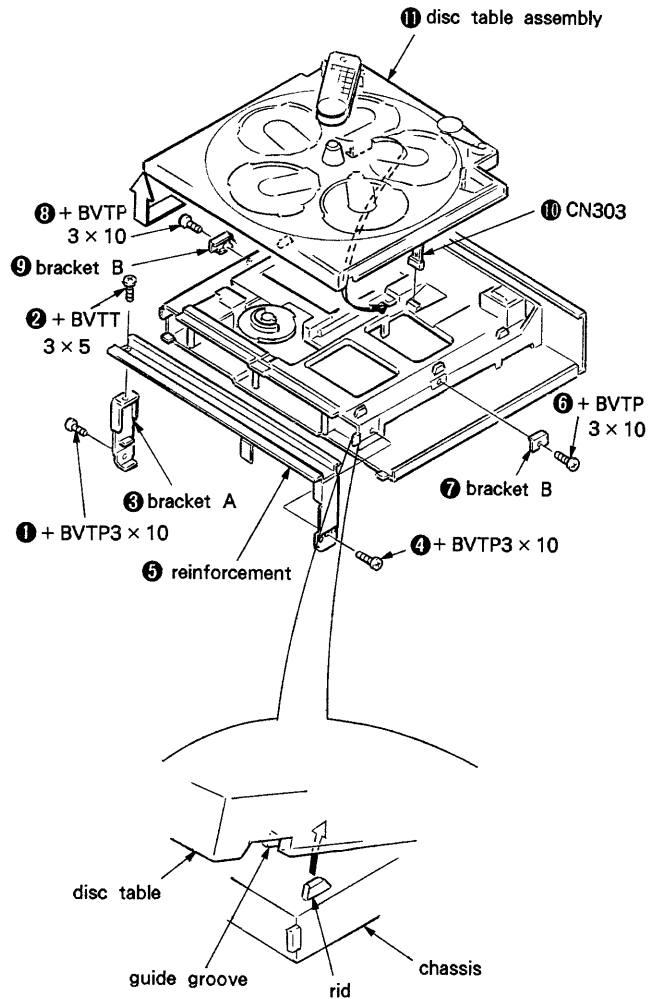

2-2. BEFORE ADJUSTMENTS

Note: Follow the disassembly procedure in the numerical order given.

1. Remove the case.
2. Remove the frontpanel assembly.

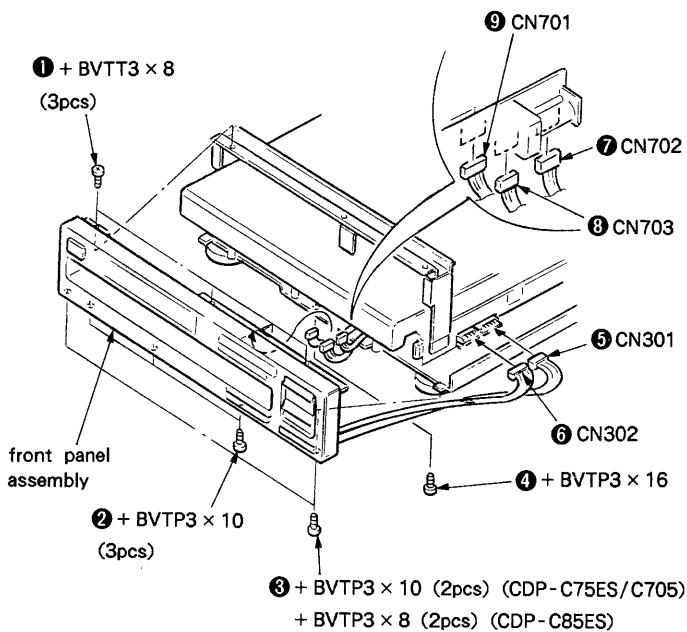

Place disc table so that 5 rids on the chassis top enter the guide grooves on the bottom of the disk table.

4. Remove the chucking pulley.

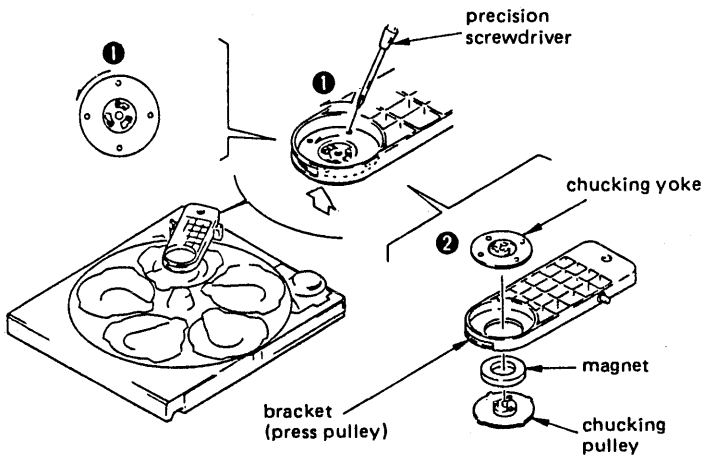

5. When the optical block is down under, move up it by rotating gear (loading A) in the arrow A direction with hands.

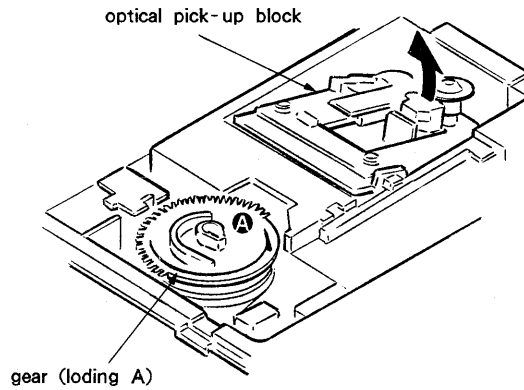

2-3. SERVICE MODE

1. Operation Check

If the disc table is removed, perform the settings as described below.

1. Remove the disc and then the magnet from the bracket.
2. Use the magnet to fix the disc in position.
3. Connect test point IC302 (pin 79) to ground with a lead wire.
4. Set the power switch (S901) to on.
5. When the panel switch is pressed, the unit operates normally. (The OPEN/CLOSE (S804) and DISC SKIP (S834) switches are disabled.)

2. Display Check

1. Connect test point IC801 (pin 23) to ground with a lead wire.
2. Set the power switch (S901) to on.
3. Press the switches on the panel and check that each of the corresponding indicators lights.

[MAIN BOARD] - Conductor Side -

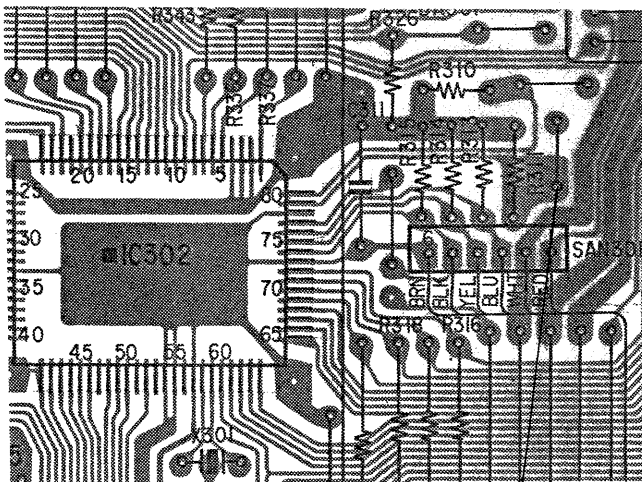

[DISPLAY BOARD] - Conductor Side -

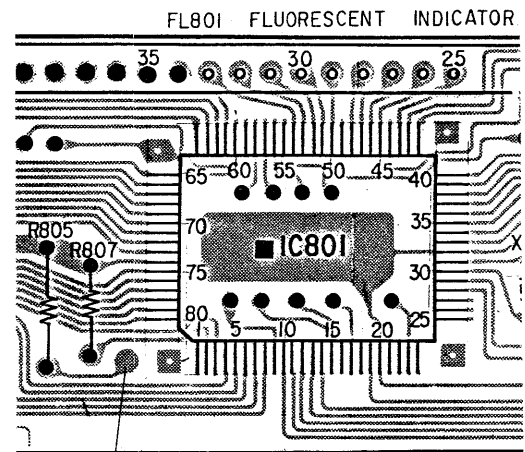

2-4. ELECTRICAL ADJUSTMENTS

1. Perform adjustments in the order given.
2. Use YEDS-18 disc (3-702-101-01) unless otherwise indicated.
3. Use the oscilloscope with more than 10MΩ impedance.

RF Level Check

Procedure :

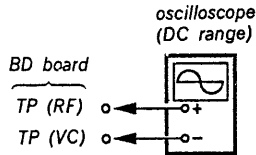

1. Connect oscilloscope to test point TP (RF) and TP (VC) on BD board.
2. Confirm that RF level and eye pattern is optimum. Optimum eye pattern means that shape "◇" can be clearly distinguished at the center of the wave form.

RF signal Reference Waveform (eye pattern)

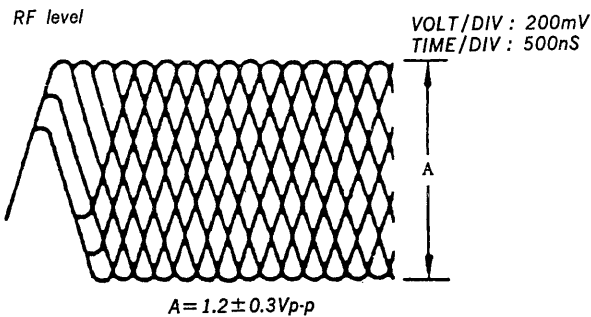

REFERENCE

E-F Balance Check

Procedure :

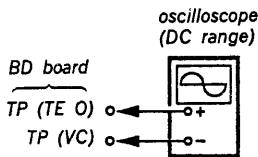

1. Connect test point TP (ADJ) and TP (TES) to ground with lead wire.
2. Connect oscilloscope to test point TP (TE O) and TP (VC) on BD board.
3. Turn POWER switch on.
4. Put disc (YEDS-18) in and playback.
5. Confirm that the oscilloscope waveform is symmetrical on the top and bottom in relation to 0V.
6. After check, remove the lead wire connected in step 1.

Note : Take sweep time as long as possible to obtain best waveform.

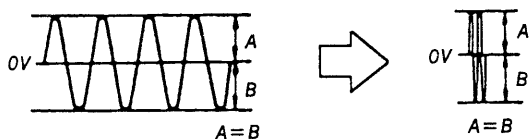

RF PLL Free-run Frequency Check

Procedure :

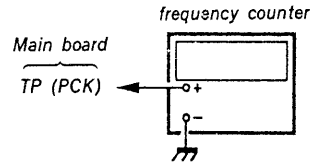

1. Turn POWER switch on.
2. Put disc (YEDS-18) in and playback.
3. Confirm that reading on frequency counter is 4.3218MHz.

Focus/Tracking Gain Adjustment

A frequency response analyzer is necessary in order to perform this adjustment exactly.

However, this gain has a margin, so even if it is slightly off, there is no problem. Therefore, do not perform this adjustment.

Focus/tracking gain determines the pick-up follow-up (vertical and horizontal) relative to mechanical noise and mechanical shock when the 2-axis device operate.

However, as these reciprocate, the adjustment is the point where both are satisfied.

- When gain is raised, the noise when the 2-axis device operates increases.
- When gain is lowered, mechanical shock and skipping occurs more easily.
- When gain adjustment is off, the symptoms below appear.

	Gain	Focus	Tracking
Symptoms			
• The time until music starts becomes longer for STOP →▷ PLAY or automatic selection. (◀◀, ▶▶ buttons pressed.) (Normally takes about 1 seconds.)		low	low or high
• Music does not start and disc continues to rotate for STOP →▷ PLAY or automatic selection. (◀◀, ▶▶ buttons pressed.)		—	low
• Sound is interrupted during PLAY. Or time counter display stops progressing.		—	low
• More noise during 2-axis device operation.	high	high	high

The following is a simple adjustment method.

—Primary Adjustment—

Note : Since exact adjustment cannot be performed, remember the positions of the controls before performing the adjustment.

If the positions after the primary adjustment are only a little different, return the controls to the original position.

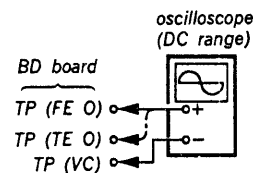

Procedure :

1. Keep the set horizontal.
If the set is not horizontal, this adjustment cannot be performed due to the gravity against the 2-axis device.
2. Insert disc (YEDS-18) and press ▷ PLAY button.
3. Connect oscilloscope to TP (FEO) and TP (VC) on BD board.
4. Adjustment RV102 on digital board so that the waveform is as shown in the figure below. (focus gain adjustment)

VOLT/DIV : 100mV
TIME/DIV : 2mS

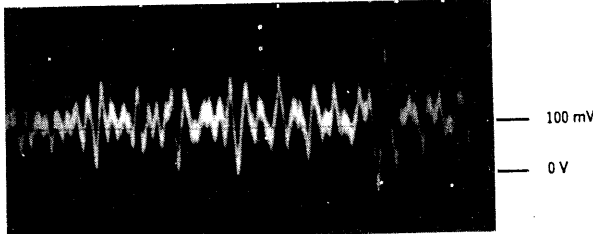

• Incorrect Examples (DC level changes more than on adjusted waveform)

low focus gain

VOLT/DIV : 100mV
TIME/DIV : 2mS

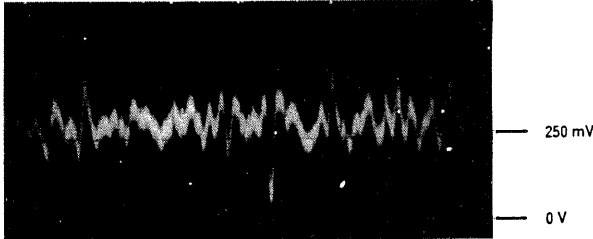

high focus gain

VOLT/DIV : 100mV
TIME/DIV : 2mS

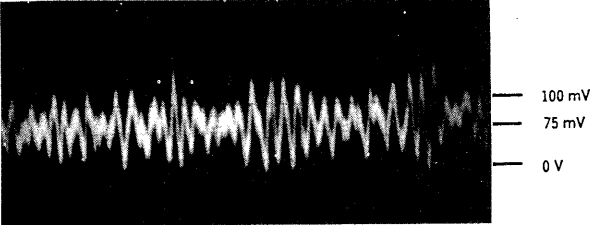

5. Connect oscilloscope to TP (TEO) and TP (VC) on BD board.
6. Adjusted RV101 on digital board so that the waveform is as shown the figure below. (tracking gain adjustment)

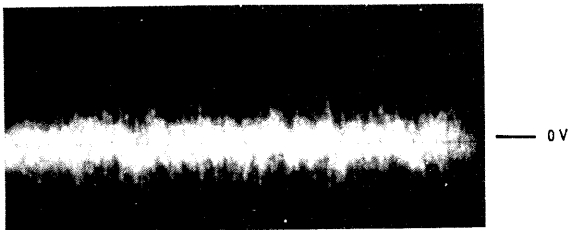

• Incorrect Examples (fundamentia wave appears)

low tracking gain

VOLT/DIV : 1V
TIME/DIV : 2mS

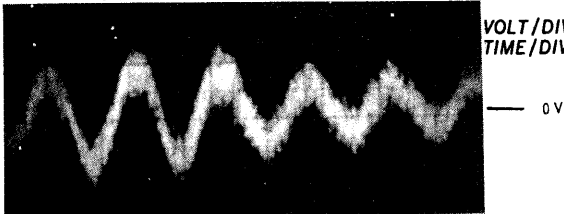

high tracking gain
(high fundamental wave)
than for low gain

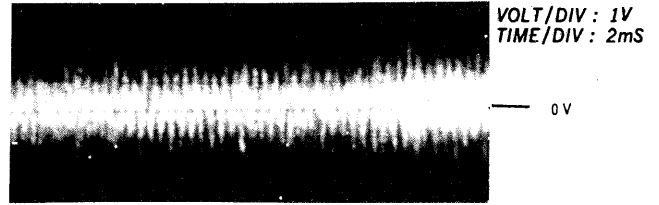

**Adjustment Locations :
[BD board]**

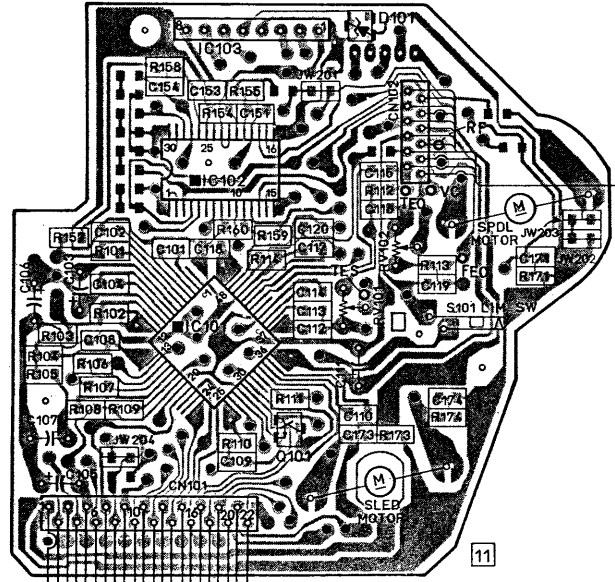

SECTION 3 DIAGRAMS

3-1. SEMICONDUCTOR LEAD LAYOUTS

CXD2500Q
MSC62408-009GS-K
μ PD-75512GF-034-3B9

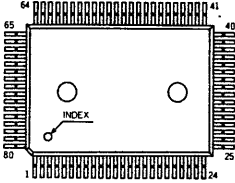

MARKING SIDE VIEW

GP1U52XB

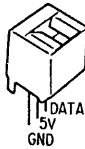

DTA114ES
DTC144ES



2SD774-5
2SD774-34



GP-1A521

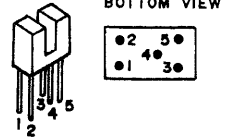

CXD2552Q

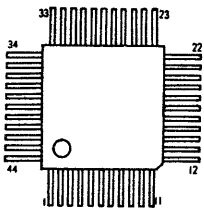

LC3564PML-15

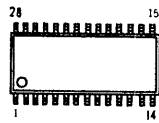

(Top view)

DTC114EF



AA5534S

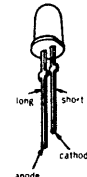

RD5.1JS-B1
RD5.6ES-B
1SS202-1
11EQS04

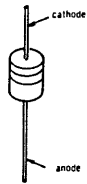

2SC3622A-K

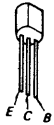

BG5535S

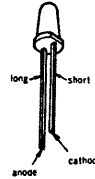

M5F7807



2SB1094-L

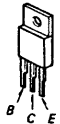

10E2N

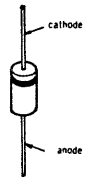

GP1F31T

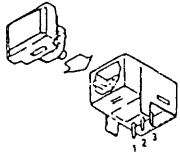

3-2. CIRCUIT BOARDS LOCATION

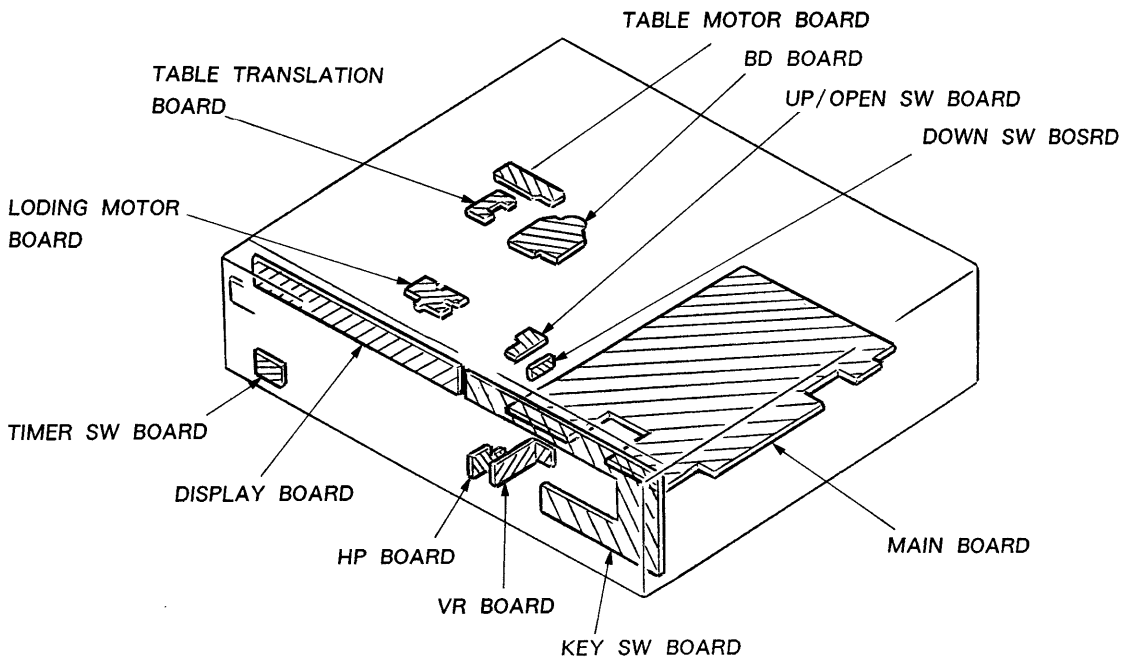

3-3. BLOCK DIAGRAM

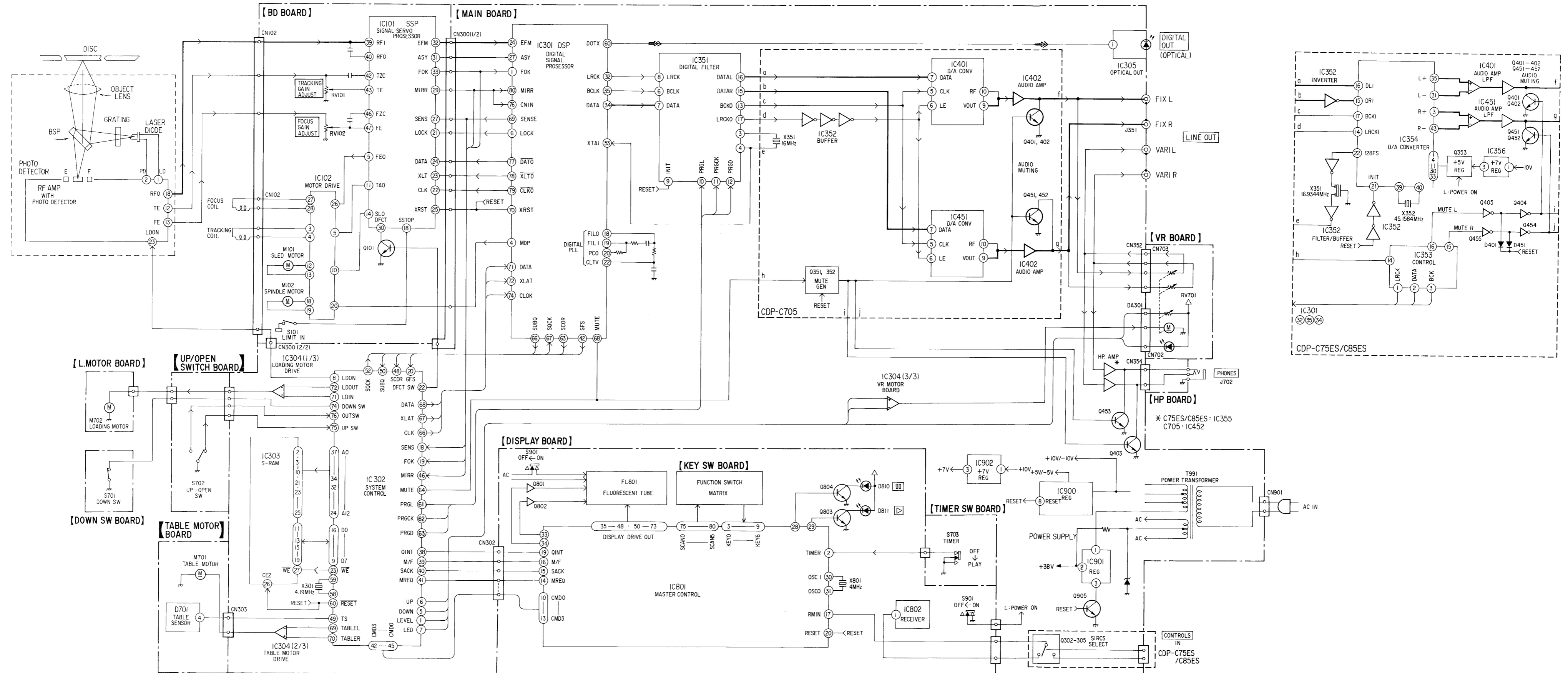

3-4. IC BLOCK DIAGRAMS

• IC301 CXD2500Q

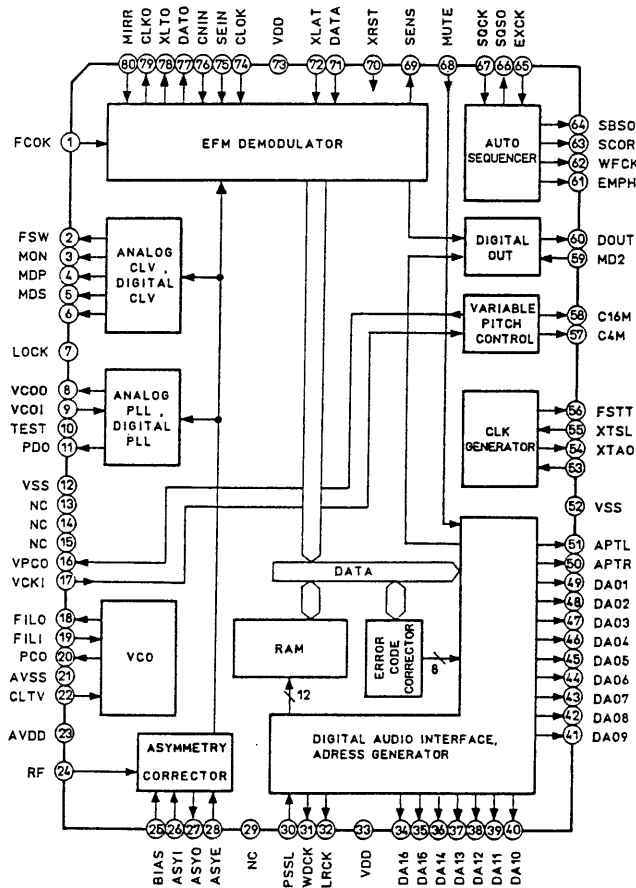

• IC354 CXD2552Q (C75ES/C85ES MODEL)

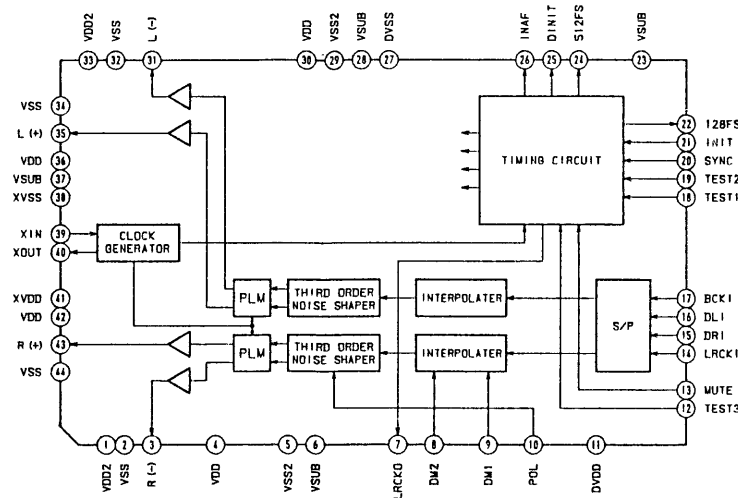

• IC401,451 AD1860N - K (C705 MODEL)

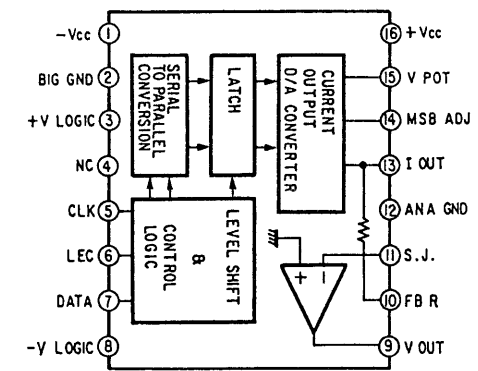

• IC900 M5290P-16

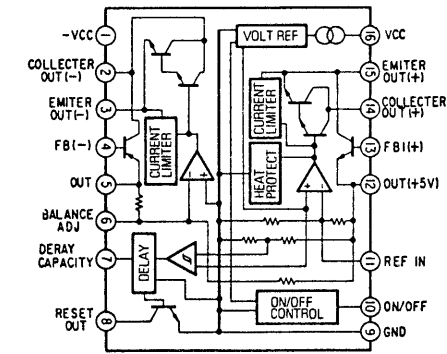

• IC353 CXD2553S (C75ES/C85ES MODEL)

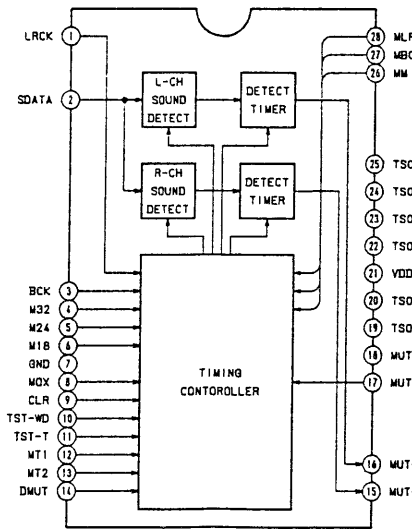

• IC101 CXD1372Q

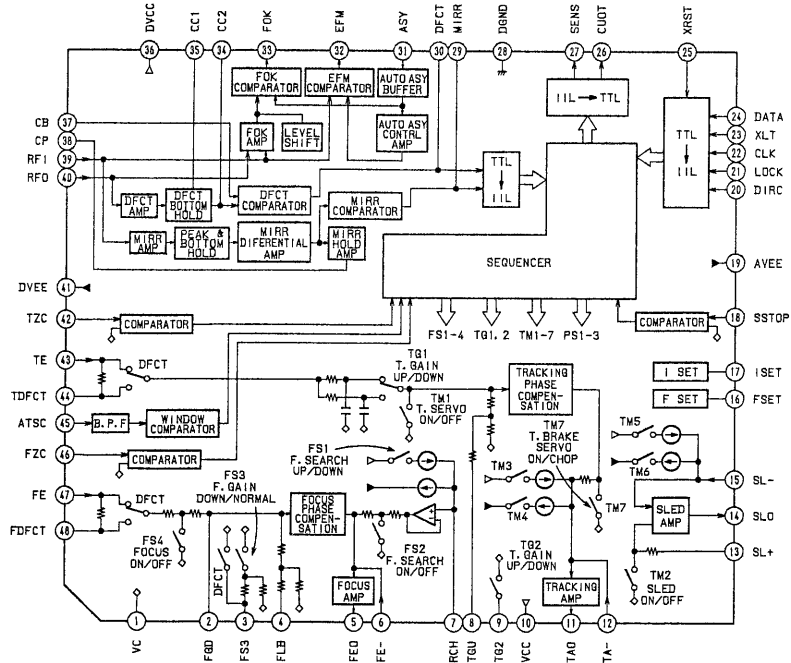

• IC351 CXD2554P

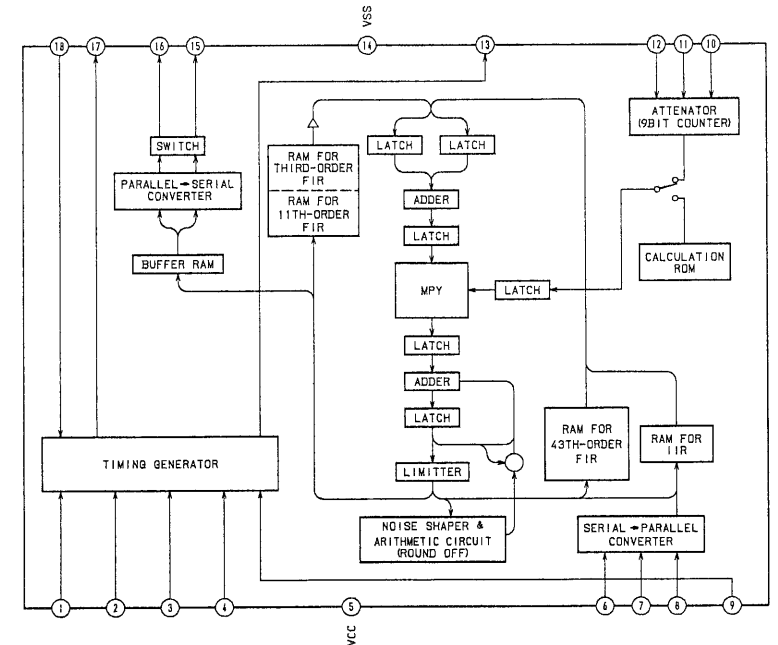

3-5. PRINTED WIRING BOARDS — MAIN BOARD — See page 10 for Semiconductor Lead Layouts and Circuit Boards Location.

• Semiconductor Location

C75ES/C85ES Model		C705 Model	
Ref. No.	Location	Ref. No.	Location
D301	F-13	D351	C-19
D302	F-13	D701	I-22
D303	F-13	D901	C-26
D351	C-7	D902	D-26
D352	C-7	D903	C-27
D353	E-8	D904	C-27
D401	C-3	D905	D-27
D451	C-3	D906	H-27
D701	I-22	D907	D-27
D901	C-11	D908	C-27
D902	D-11	D909	F-27
D903	C-11	D910	F-27
D904	C-11	D911	C-26
D905	D-11	D912	D-27
D906	H-12	D913	D-27
D907	D-11	D914	C-21
D908	D-11	D915	H-18
D909	G-12		
D910	F-12	IC301	F-24
D911	D-11	IC302	G-19
D912	D-11	IC303	G-18
D913	E-11	IC304	E-19
D914	B-5	IC351	E-25
D915	H-3	IC352	D-24
D916	E-12	IC401	D-23
		IC402	D-22
IC301	F-9	IC451	F-23
IC302	G-4	IC452	D-20
IC303	G-2	IC900	F-26
IC304	E-3	IC901	G-27
IC305	F-14	IC902	G-27
IC351	E-9		
IC352	D-8	Q351	C-19
IC353	E-10	Q352	C-19
IC354	D-7	Q401	C-21
IC355	D-4	Q402	C-21
IC356	B-9	Q403	D-19
IC401	C-5	Q451	E-21
IC451	F-6	Q452	F-21
IC900	F-11	Q453	D-19
IC901	G-12	Q901	C-26
IC902	G-12	Q902	D-25
		Q903	G-27
Q302	F-12	Q904	G-27
Q303	F-13	Q905	G-27
Q304	F-13		
Q305	F-13		
Q351	C-8		
Q352	C-8		
Q353	C-8		
Q401	C-5		
Q402	D-5		
Q403	C-3		
Q404	C-3		
Q405	C-4		
Q451	E-5		
Q452	E-5		
Q453	D-3		
Q454	B-3		
Q455	B-4		
Q901	C-10		
Q902	D-10		
Q903	G-12		
Q904	G-12		
Q905	G-12		

Note on Mounting Diagram:

- : parts extracted from the component side.
- : parts mounted on the conductor side.
- : Through hole.
- ▨ : Pattern on the side which is seen.
- ◐ : Pattern of the rear side.

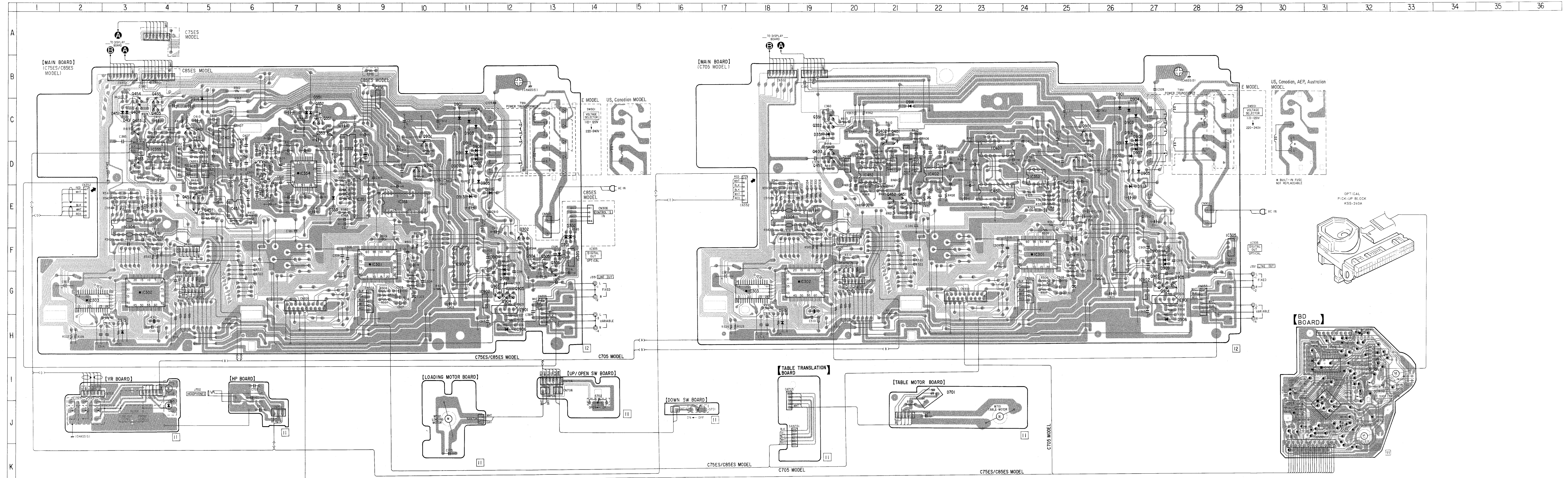

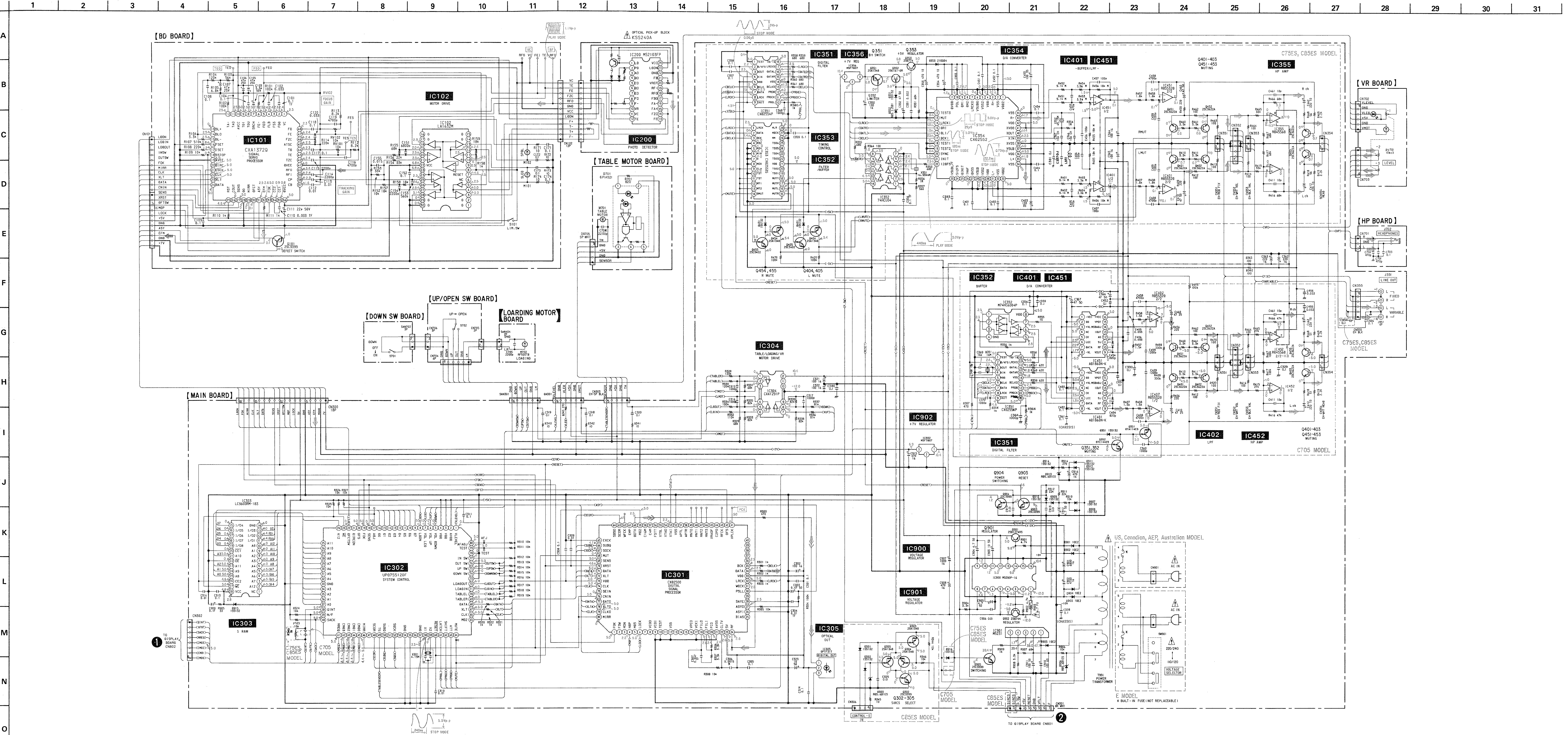

Note on Schematic Diagram:

- All capacitors are in μF unless otherwise noted. pF : μF 50WV or less are not indicated except for electrolytics and tantalums.
- All resistors are in Ω and $\frac{1}{2}\text{W}$ or less unless otherwise specified.
- ——— : B+ Line
- - - - - - : B- Line
- Voltage and waveforms are dc with respect to ground under no-signal conditions.
- no mark: PLAY
- Voltages are taken with a VOM (input impedance 10M Ω)
- Voltage variations may be noted due to normal production tolerances.
- Waveforms are taken with an oscilloscope.
- Voltage variations may be noted due to normal production tolerances.
- Signal path.
- CD
- digital out

3-7. PRINTED WIRING BOARDS — DISPLAY BOARD — See page 10 for Semiconductor Lead Layouts and Circuit Boards Location.

Semiconductor Location

Ref. No.	Location
D801	D-4
D802	E-3
D803	F-3
D804	D-3
D805	D-3
D806	D-3
D810	F-2
D811	F-3
IC801	B-6
IC802	B-2
Q801	B-7
Q802	B-7
Q803	B-8

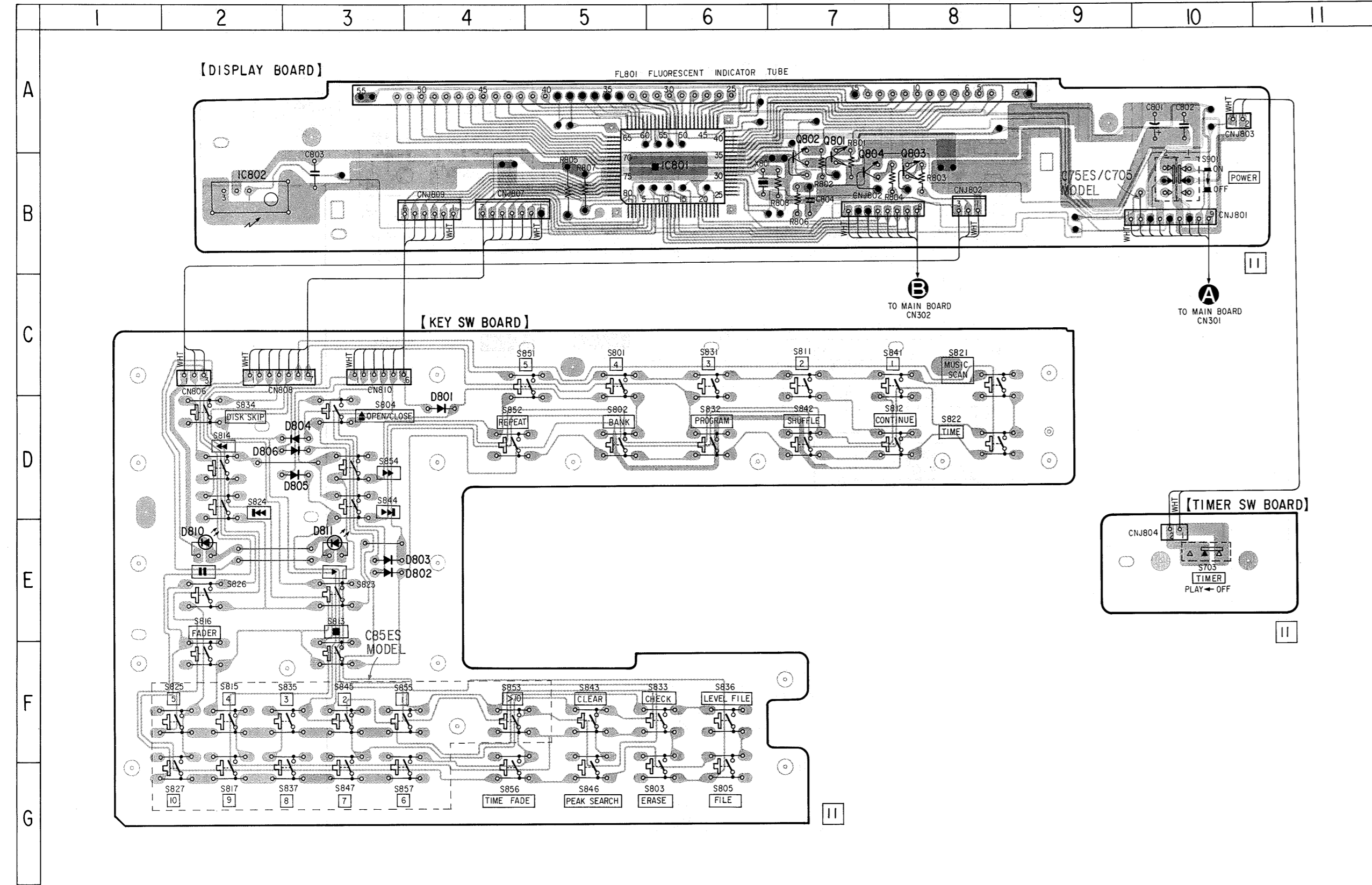

Note on Mounting Diagram:

- : parts extracted from the component side.
- : parts mounted on the conductor side.
- : Through hole.
- ▨ : Pattern on the side which is seen.
- ◊ : Pattern of the rear side.

3-8. SCHEMATIC DIAGRAM — DISPLAY BOARD — See page 14 for IC block diagram.

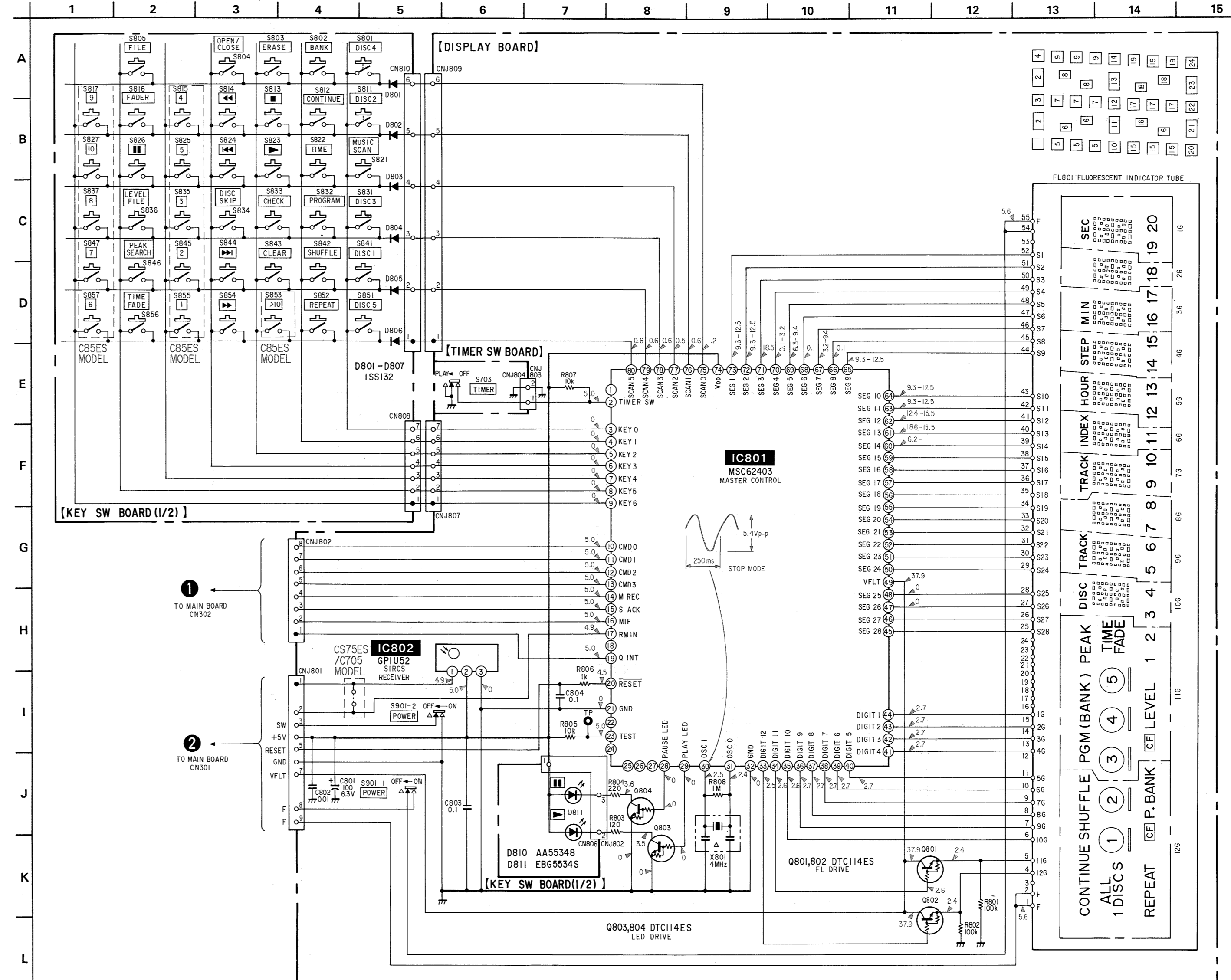

Note on Schematic Diagram:



- All capacitors are in μF unless otherwise noted. pF: μF 50WV or less are not indicated except for electrolytics and tantalums.
- All resistors are in Ω and $\frac{1}{2}W$ or less unless otherwise specified.
- : B+ Line
- Voltage and waveforms are dc with respect to ground under no-signal conditions.
- no mark: PLAY
- Volts are taken with a VOM (input impedance 10M Ω) Voltage variations may be noted due to normal production tolerances.
- Waveforms are taken with an oscilloscope. Voltage variations may be noted due to normal production tolerances.

SECTION 4 EXPLODED VIEWS

NOTE:

- The mechanical parts with no reference number in the exploded views are not supplied.
- The construction parts of an assembled part are indicated with a collation number in the remark column.
- Items marked “*” are not stocked since they are seldom required for routine service. Some delay should be anticipated when ordering these items.





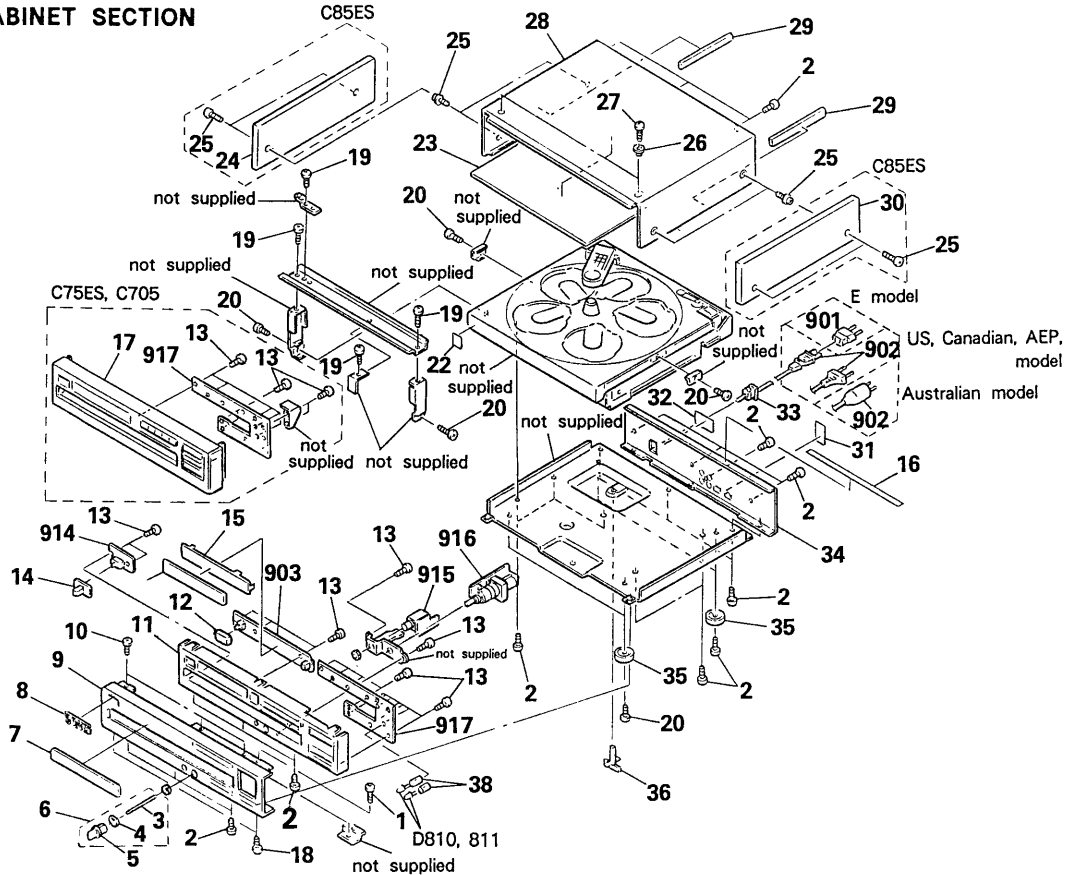

- Due to standardization, parts with part number suffix -XX and -X may be different from the parts specified in the components used on the set.
- Color Indication of Appearance Parts
Example:
(RED) ... KNOB, BALANCE (WHITE)
↑ Cabinet's Color ↑ Parts' Color

The components identified by mark  or dotted line with mark  are critical for safety. Replace only with part number specified.

Les composants identifiés par une marque  sont critiques pour la sécurité. Ne les remplacer que par une pièce portant le numéro spécifié.

4-1. CABINET SECTION



No.	Part No.	Description	Remarks	No.	Part No.	Description	Remarks
1	7-682-546-09	(C85ES)...SCREW +B 3X5		30	X-4924-466-1	(C85ES)...PANEL (R) ASSY, SIDE	
2	7-685-647-79	SCREW +BVTP 3X10 TYPE2 N-S		31	*3-704-217-02	(US,Canadian)...LABEL	
3	4-922-979-01	INDICATOR		32	*4-885-838-01	(AEP,E,Australian)...LABEL, CLASS 1	
4	4-922-978-01	HOLDER (FIBER)		33	*3-703-244-00	(EXCEPT E)...BUSHING (2104), CORD	
5	4-922-977-01	KNOB (HP)			*3-703-571-11	(E)...BUSHING (S)(4516), CORD	
6	A-4675-298-A	KNOB (HP) ASSY		34	*4-934-360-01	(C85ES:US).....PANEL, BACK	
7	4-937-926-01	(C85ES)...PLATE (FL), INDICATION			*4-934-360-11	(C75ES:US).....PANEL, BACK	
8	4-908-848-01	(C85ES)...EMBLEM, SONY			*4-934-360-21	(C705:US).....PANEL, BACK	
9	4-937-932-01	(C85ES)...PANEL, FRONT			*4-934-360-31	(C705:Canadian)...PANEL, BACK	
10	7-682-548-04	SCREW +BVT 3X8 (S)			*4-934-360-41	(C705:AEP).....PANEL, BACK	
11	X-4924-467-1	(C85ES)...PANEL (BASE) ASSY			*4-934-360-51	(C705:E).....PANEL, BACK	
12	4-922-921-01	BUTTON (POWER)			*4-934-360-61	(C705:Australian)...PANEL, BACK	
13	4-928-635-01	SCREW, +BV (2.6X8) TAPPING			*4-934-360-71	(C75ES:Canadian)...PANEL, BACK	
14	4-922-518-11	KNOB (TIMER)			*4-934-360-81	(C85ES:E).....PANEL, BACK	
15	*4-924-481-01	BRACKET (FL)		35	X-4924-463-1	(EXCEPT C705:US,Canadian)...FOOT ASSY	
16	*4-927-653-01	SHEET (F/P)			X-4924-464-1	(C705:US,Canadian).....FOOT ASSY	
17	X-4924-468-1	(C75ES).....PANEL ASSY, FRONT		36	4-937-945-01	PLATE (TRANSPORT), LOCK	
	X-4924-469-1	(C705:US,Canadian).....PANEL ASSY, FRONT		37	7-685-650-79	SCREW +BVTP 3X16 TYPE2 N-S	
	X-4924-470-1	(C705:AEP,E,Australian).....PANEL ASSY, FRONT		38	4-937-949-01	HOLDER, LED	
18	3-703-685-21	SCREW (+BV 3X8)		901	 1-526-007-11	(C705:E).....ADAPTOR, CONVERSION 2P	
19	7-685-870-01	SCREW +BVTT 3X5 (S)			 1-526-565-00	(C85ES:E).....AC PLUG ADAPTOR	
20	7-685-647-79	SCREW +BVTP 3X10 TYPE2 N-S		902	 1-575-104-11	(E).....CORD, POWER	
21	*3-703-710-41	STICKER, SONY SYMBOL (12)			 1-575-105-11	(US,Canadian)...CORD, POWER	
23	A-4675-309-A	(C75ES/C85ES)...REINFORCEMENT (TOP PLATE) ASSY			 1-575-453-11	(AEP).....CORD, POWER	
24	X-4924-465-1	(C85ES)...PANEL (L) ASSY, SIDE			 1-575-677-11	(Australian)...CORD, POWER	
25	3-704-366-01	(C75ES/C705)...SCREW (CASE) (M3X8)		903	*A-4617-468-A	(C85ES).....MOUNTED PCB, DISPLAY	
	4-933-446-01	(C85ES).....SCREW (SIDE PANEL)			*A-4617-469-A	(C75ES,C705)...MOUNTED PCB, DISPLAY	
26	4-928-025-11	ESCUTCHEON (TOP PLATE)		914	*1-635-141-11	PC BOARD, TIMER SW	
27	7-682-547-09	SCREW (M3X6), S TITE, + BTT		915	*1-635-144-11	PC BOARD, HP	
28	*4-937-934-01	CASE		916	*1-635-143-11	PC BOARD, VR	
29	*4-929-561-01	(C75ES/C705)...CUSHION (CASE)		917	*1-635-142-11	PC BOARD, KEYBOARD	

4-2. DISC TABLE SECTION

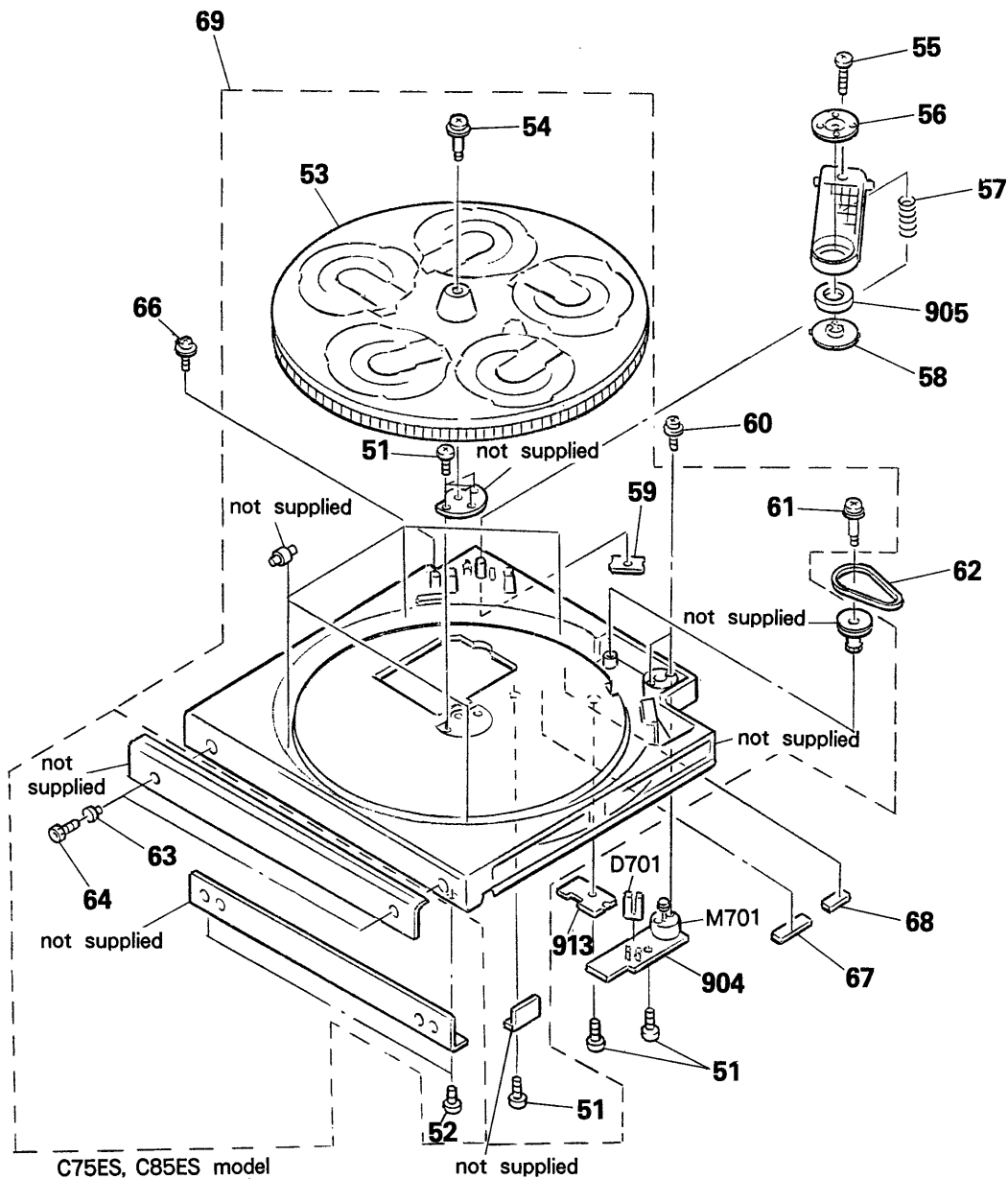

No.	Part No.	Description	Remarks	No.	Part No.	Description	Remarks
51	7-685-647-79	SCREW +BVTP 3X10 TYPE2 N-S		66	7-685-648-79	SCREW (M3X12), TAPPING	
52	4-928-635-01	(C75ES/C85ES)...SCREW, +BV(2.6X8)	TAPPING	67	4-937-973-01	CUSHION (RUBBER A)	
53	4-926-383-01	(C705).....TABLE (B), DISK		68	4-937-974-01	CUSHION (RUBBER B)	
	4-926-383-11	(C75ES/C85ES)...TABLE (B), DISK		69	A-4604-530-A	(C705).....TABLE ASSY, DISK	
54	4-926-384-01	SCREW, STEP			A-4604-533-A	(C75ES/C85ES)...TABLE ASSY, DISK	
55	7-682-554-04	SCREW +B 3X25		904	*1-635-137-11	(C75ES/C85ES)...PC BOARD, TABLE MOTOR	
56	4-921-029-01	YOKE, CHUCKING			*1-635-148-11	(C705).....PC BOARD, TABLE MOTOR	
57	4-926-395-01	SPRING, COMPRESSION		905	1-452-340-21	MAGNET	
58	4-921-022-01	PULLEY, CHUCKING		913	*1-635-138-11	(C75ES/C85ES) ...PC BOARD, TABLE TRANSLATION	
59	*4-926-388-01	BRACKET (ADJUSTMENT)			*1-635-150-11	(C705)...PC BOARD, TABLE TRANSLATION	
60	7-621-759-35	+PSW, 2.6X5		D701	8-719-970-19	(C75ES/C85ES)...DIODE GP1A521	
61	4-923-597-01	SCREW, STEP		M701	A-4604-585-A	MOTOR ASSY, ROTARY	
62	4-926-399-01	BELT					
63	4-934-307-01	(C75ES/C85ES)...ESCUTCHEON					
64	7-683-401-04	(C75ES/C85ES)...BOLT, HEXAGON SOCKET 3X4					
65	7-685-870-01	SCREW +BVTT 3X5 (S)					

4-3. CHASSIS SECTION

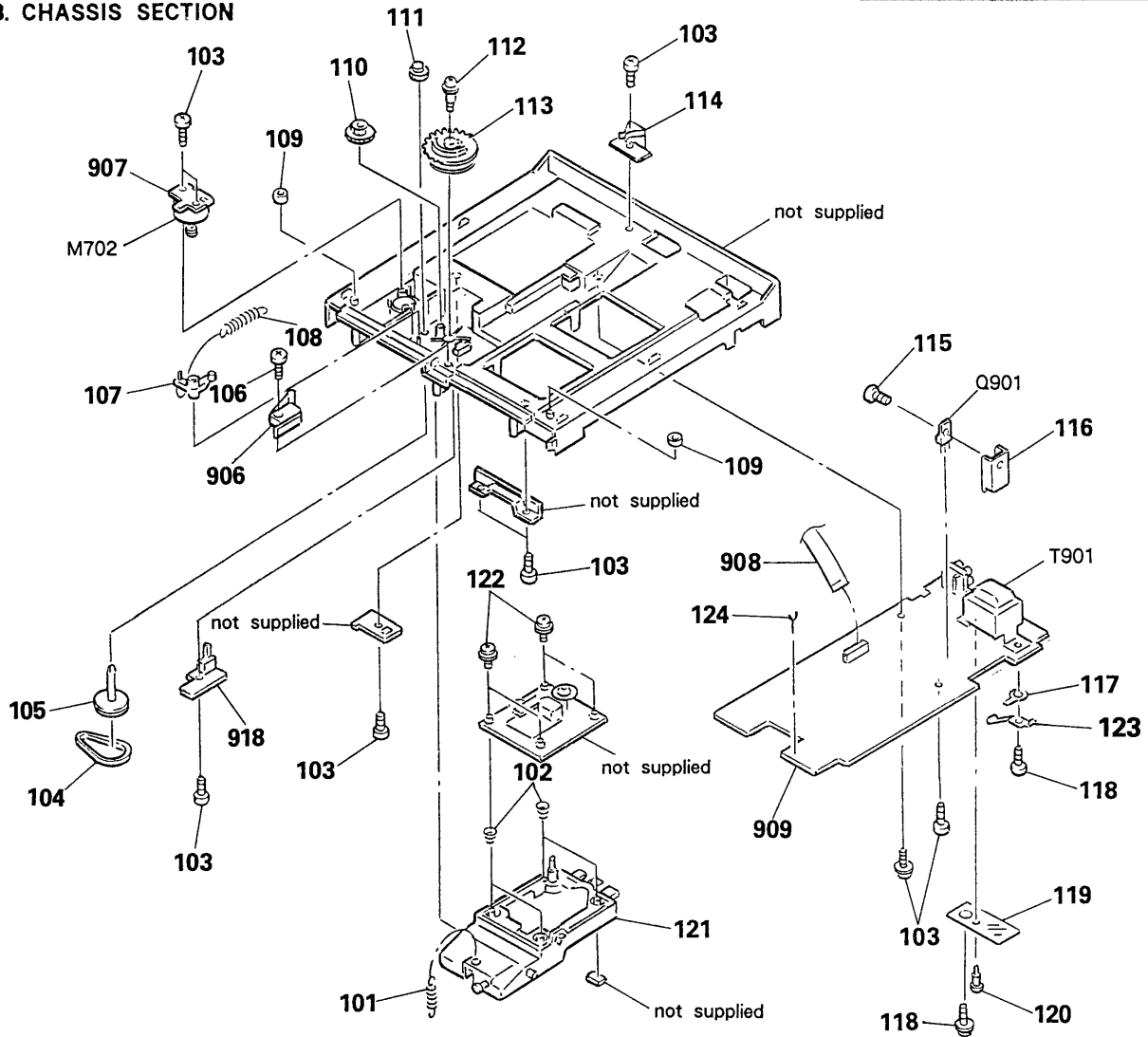





Note:
The components identified by mark Δ or dotted line with mark Δ are critical for safety. Replace only with part number specified.

Note:
Les composants identifiés par une marque Δ sont critiques pour la sécurité. Ne les remplacer que par une pièce portant le numéro spécifié.

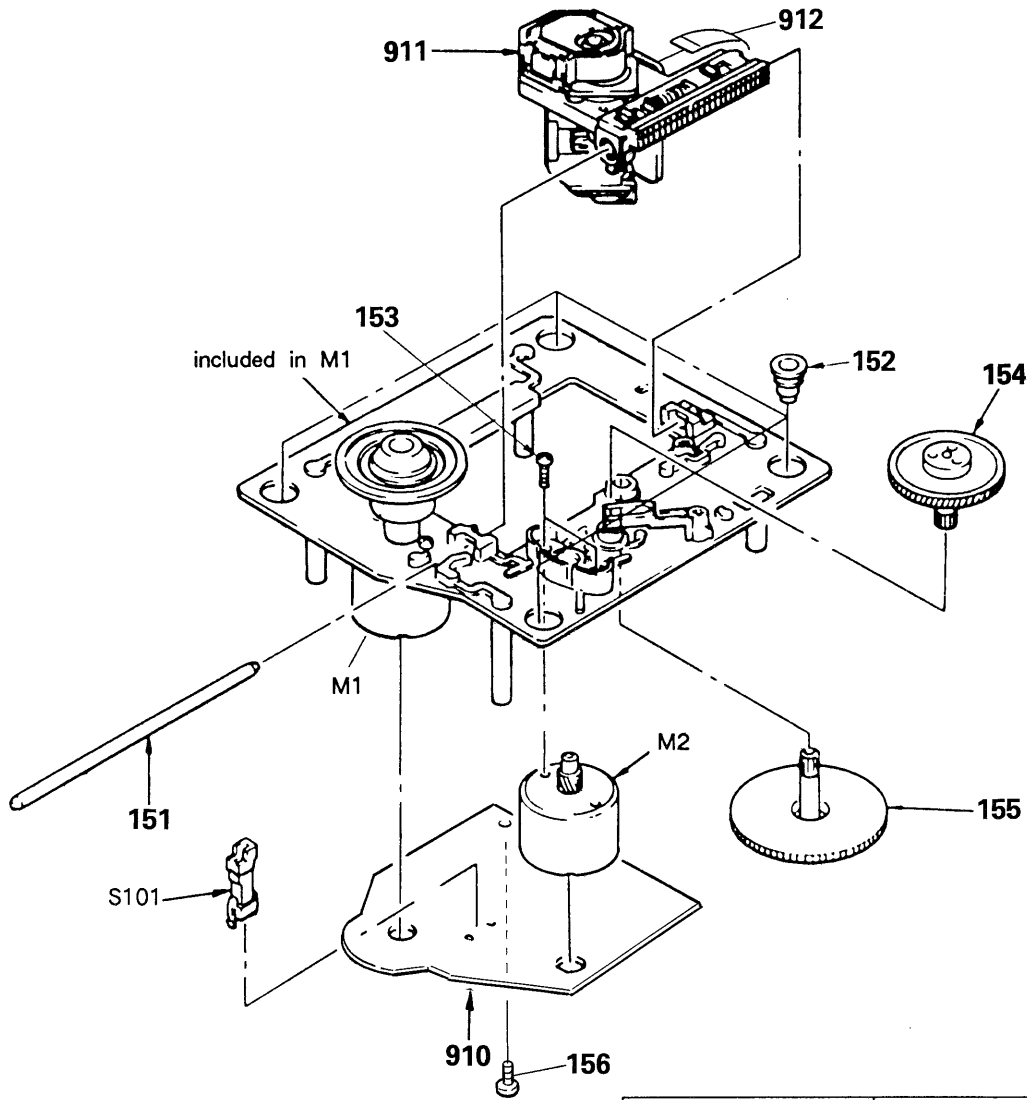
No.	Part No.	Description	Remarks	No.	Part No.	Description	Remarks
101	4-937-911-01	SPRING, TENSION		906	*1-635-135-11 (C75ES/C85ES)...	PC BOARD, DOWN SW	
102	4-917-541-01	SPRING (B)			*1-635-146-11 (C705).....	PC BOARD, DOWN SW	
103	7-685-647-79	SCREW +BVTP 3X10 TYPE2 N-S		907	*1-635-139-11 (C75ES/C85ES)...	PC BOARD, LOADING MOTOR	
104	4-934-388-01	BELT			*1-635-147-11 (C705).....	PC BOARD, LOADING MOTOR	
105	4-934-390-01	PULLEY (LOADING)		908	1-535-850-11	JUMPER, FILM (WITH TERMINAL)	
106	7-685-136-19	SCREW +P 2.6X12 TYPE2 NON-SLIT		909	*A-4617-462-A (C705:US,Canadian,AEP,Australian)	...MOUNTED PCB, MAIN	
107	4-917-519-01	LEVER, SET			*A-4617-463-A (C705:E).....	MOUNTED PCB, MAIN	
108	4-924-412-01	SPRING (B), TENSION			*A-4617-475-A (C85ES:US).....	MOUNTED PCB, MAIN	
109	*4-934-382-01	CUSHION			*A-4617-476-A (C75ES).....	MOUNTED PCB, MAIN	
110	4-934-381-01	GEAR (LOADING C)			*A-4617-529-A (C85ES:E).....	MOUNTED PCB, MAIN	
111	4-934-375-01	GEAR (LOADING B)		918	*1-635-136-11 (C75ES/C85ES)...	PC BOARD, UP/OPEN SW	
112	4-926-317-01	SCREW, STEP			*1-635-149-11 (C705).....	PC BOARD, UP/OPEN SW	
113	4-934-391-01	GEAR (LOADING A)		M702	A-4604-528-A	MOTOR ASSY, LOADING	
114	4-937-944-01	SPRING, LEAF		Q901	8-729-111-67	TRANSISTOR 2SB1094-L	
115	7-682-548-04	SCREW +BVTT 3X8 (S)		SW901	1-571-722-11	SWITCH, VOLTAGE SELECTOR	
116	*4-875-327-01	HEAT SINK		T901 Δ .1-450-133-11	(US,Canadian).....	TRANSFORMER, POWER	
117	4-870-539-00	PLATE, GROUND		T901 Δ .1-450-134-11	(AEP,Australian)...	TRANSFORMER, POWER	
118	7-685-647-79	SCREW, TAPPING		T901 Δ .1-450-135-11	(E).....	TRANSFORMER, POWER	
119	*4-934-386-01	SHEET (INSULATING)					
120	3-531-576-11	RIVET					
121	*4-934-373-01	BRACKET (BU)					
122	4-933-134-01	SCREW (+PTPW M2.6X6)					
123	*4-930-512-01	PLATE, GROUND					
124	*4-352-844-01	PIN, LEAD, COATING					

4-4. OPTICAL PICK-UP BLOCK (BU-5BD3)



<p>Note: The components identified by mark  or dotted line with mark  are critical for safety. Replace only with part number specified.</p>	<p>Note: Les composants identifiés par une marque  sont critiques pour la sécurité. Ne les remplacer que par une pièce portant le numéro spécifié.</p>
--	--

No.	Part No.	Description	Remarks	No.	Part No.	Description	Remarks
151	4-917-565-01	SHAFT, SLED		910	*A-4617-371-A	MOUNTED PCB, BD	
152	4-933-126-01	INSULATOR (A)		911	 .8-848-144-11	DEVICE, OPTICAL KSS-240A	
153	7-621-255-15	SCREW +P 2X3		912	1-575-001-11	WIRE, FLAT TYPE (12 CORE)	
154	4-917-567-01	GEAR (M)		M1	X-4917-523-3	MOTOR ASSY, SPINDLE	
155	4-917-564-01	GEAR (P), FLATNESS		M2	X-4917-504-1	MOTOR ASSY, SLED	
156	7-685-134-19	SCREW +BTP 2.6X8 TYPE2 N-S		S101	1-572-085-11	SWITCH, LEAF	

SECTION 5 ELECTRICAL PARTS LIST

NOTE:

- Due to standardization, replacements in the parts list may be different from the parts specified in the diagrams or the components used on the set.
- Items marked "★" are not stocked since they are seldom required for routine service. Some delay should be anticipated when ordering these items.
- If there are two or more same circuits in a set such as a stereophonic machine, only typical circuit parts may be indicated and capacitors and resistors in other same circuits may be omitted.

CAPACITORS:
MF: μ F, PF: μ F.

RESISTORS
• All resistors are in ohms.
• F: nonflammable

COILS
• MMH: mH, UH: μ H

SEMICONDUCTORS
In each case, U: μ , for example:
UA...: μ A..., UPA...: μ PA...,
UPC...: μ PC, UPD...: μ PD...

The components identified by mark Δ or dotted line with mark Δ are critical for safety. Replace only with part number specified.

Les composants identifiés par une marque Δ sont critiques pour la sécurité. Ne les remplacer que par une pièce portant le numéro spécifié.

Ref.No.	Part No.	Description	Ref.No.	Part No.	Description			
901	Δ .1-526-007-11	(C705:E)...ADAPTOR, CONVERSION 2P	C111	1-131-367-00	TANTALUM	22MF	20%	16V
	Δ .1-526-565-00	(C85ES:E).....AC PLUG ADAPTOR	C112	1-164-232-11	CERAMIC CHIP	0.01MF	10%	50V
902	Δ .1-575-104-11	(E).....CORD, POWER	C113	1-164-232-11	CERAMIC CHIP	0.01MF	10%	50V
	Δ .1-575-105-11	(US,Canadian)...CORD, POWER	C114	1-164-161-11	CERAMIC CHIP	0.0022MF	10%	50V
	Δ .1-575-453-11	(AEP).....CORD, POWER	C115	1-164-161-11	CERAMIC CHIP	0.0022MF	10%	50V
	Δ .1-575-677-11	(Australian)...CORD, POWER	C117	1-163-038-00	CERAMIC CHIP	0.1MF		25V
903	*A-4617-468-A	(C85ES).....MOUNTED PCB, DISPLAY	C118	1-163-038-00	CERAMIC CHIP	0.1MF		25V
	*A-4617-469-A	(C75ES/C705)...MOUNTED PCB, DISPLAY	C119	1-164-161-11	CERAMIC CHIP	0.0022MF	10%	50V
904	*1-635-137-11	(C75ES/C85ES)...PC BOARD, TABLE MOTOR	C120	1-163-989-11	CERAMIC CHIP	0.033MF	10%	25V
	*1-635-148-11	(C705).....PC BOARD, TABLE MOTOR	C151	1-163-019-00	CERAMIC CHIP	0.0068MF	10%	50V
905	1-452-340-21	MAGNET	C152	1-163-038-00	CERAMIC CHIP	0.1MF		25V
906	*1-635-135-11	(C75ES/C85ES)...PC BOARD, DOWN SW	C153	1-163-006-11	CERAMIC CHIP	560PF	10%	50V
	*1-635-146-11	(C705).....PC BOARD, DOWN SW	C154	1-164-161-11	CERAMIC CHIP	0.0022MF	10%	50V
907	*1-635-139-11	(C75ES/C85ES)..PC BOARD, LOADING MOTOR	C155	1-163-023-00	CERAMIC CHIP	0.015MF	10%	50V
	*1-635-147-11	(C705).....PC BOARD, LOADING MOTOR	C171	1-163-038-00	CERAMIC CHIP	0.1MF		25V
908	1-535-850-11	JUMPER, FILM (WITH TERMINAL)	C172	1-163-038-00	CERAMIC CHIP	0.1MF		25V
909	*A-4617-462-A	(C705:US,Canadian,AEP,Australian)	C173	1-163-038-00	CERAMIC CHIP	0.1MF		25V
	MOUNTED PCB, MAIN	C174	1-163-038-00	CERAMIC CHIP	0.1MF		25V
	*A-4617-463-A	(C705:E).....MOUNTED PCB, MAIN	C301	1-164-159-11	CERAMIC	0.1MF		50V
	*A-4617-475-A	(C85ES:US).....MOUNTED PCB, MAIN	C302	1-126-023-11	(C75ES/C85ES)...ELECT	100MF	20%	16V
	*A-4617-476-A	(C75ES).....MOUNTED PCB, MAIN	C302	1-126-101-11	(C705).....ELECT	100MF	20%	16V
	*A-4617-529-A	(C85ES:E).....MOUNTED PCB, MAIN	C303	1-124-902-00	ELECT	0.47MF	20%	50V
910	*A-4617-371-A	MOUNTED PCB, BD	C304	1-136-153-00	FILM	0.01MF	5%	50V
911	Δ .8-848-144-11	DEVICE, OPTICAL KSS-240A	C305	1-164-159-11	CERAMIC	0.1MF		50V
912	1-575-001-11	WIRE, FLAT TYPE (12 CORE)	C306	1-106-347-00	MYLAR	0.0015MF	5%	50V
913	*1-635-138-11	(C75ES/C85ES)	C307	1-136-161-00	FILM	0.047MF	5%	50V
		...PC BOARD, TABLE TRANSLATION	C308	1-164-159-11	CERAMIC	0.1MF		50V
	*1-635-150-11	(C705)...PC BOARD, TABLE TRANSLATION	C309	1-161-379-00	CERAMIC	0.01MF	30%	16V
914	*1-635-141-11	PC BOARD, TIMER SW	C310	1-161-379-00	CERAMIC	0.01MF	30%	16V
915	*1-635-144-11	PC BOARD, HP	C311	1-164-159-11	CERAMIC	0.1MF		50V
916	*1-635-143-11	PC BOARD, VR	C313	1-164-159-11	CERAMIC	0.1MF		50V
917	*1-635-142-11	PC BOARD, KEYBOARD	C314	1-161-379-00	CERAMIC	0.01MF	30%	16V
918	*1-635-136-11	(C75ES/C85ES)...PC BOARD, UP/OPEN SW	C315	1-162-294-31	CERAMIC	0.001MF	10%	50V
	*1-635-149-11	(C705).....PC BOARD, UP/OPEN SW	C316	1-162-294-31	CERAMIC	0.001MF	10%	50V
C101	1-163-038-00	CERAMIC CHIP 0.1MF	C317	1-162-294-31	CERAMIC	0.001MF	10%	50V
C102	1-163-989-11	CERAMIC CHIP 0.033MF	C318	1-164-159-11	CERAMIC	0.1MF		50V
C103	1-126-094-11	ELECT 4.7MF	C319	1-164-159-11	CERAMIC	0.1MF		50V
C104	1-163-038-00	CERAMIC CHIP 0.1MF	C320	1-164-159-11	CERAMIC	0.1MF		50V
C105	1-126-154-11	ELECT 47MF	C321	1-126-023-11	(C75ES/C85ES)...ELECT	100MF	20%	16V
C106	1-126-154-11	ELECT 47MF	C321	1-126-101-11	(C705).....ELECT	100MF	20%	16V
C107	1-126-154-11	ELECT 47MF	C322	1-126-023-11	(C75ES/C85ES)...ELECT	100MF	20%	16V
C108	1-163-038-00	CERAMIC CHIP 0.1MF	C322	1-126-101-11	(C705).....ELECT	100MF	20%	16V
C109	1-163-038-00	CERAMIC CHIP 0.1MF	C323	1-123-875-11	ELECT	10MF	20%	50V
C110	1-163-989-11	CERAMIC CHIP 0.033MF	C324	1-164-159-11	CERAMIC	0.1MF		50V
			C325	1-161-379-00	(C85ES)...CERAMIC	0.01MF	30%	16V

Ref.No.	Part No.	Description			
C326	1-164-159-11	CERAMIC	0.1MF		50V
C327	1-164-159-11	{C75ES/C85ES)...CERAMIC	0.1MF		50V
C328	1-164-159-11	CERAMIC	0.1MF		50V
C329	1-164-159-11	(C705)...CERAMIC	0.1MF		50V
C330	1-164-159-11	(C705)...CERAMIC	0.1MF		50V
C350	1-126-023-11	(C75ES/C85ES)...ELECT	100MF	20%	16V
C351	1-130-487-00	(C75ES/C85ES)...MYLAR	0.022MF	5%	50V
C352	1-124-910-11	(C75ES/C85ES)...ELECT	47MF	20%	50V
C353	1-124-997-11	(C75ES/C85ES)...ELECT	470MF	20%	10V
C354	1-124-997-11	(C75ES/C85ES)...ELECT	470MF	20%	10V
C355	1-136-165-00	(C75ES/C85ES)...FILM	0.1MF	5%	50V
C356	1-136-165-00	(C75ES/C85ES)...FILM	0.1MF	5%	50V
C356	1-164-159-11	(C705)...CERAMIC	0.1MF		50V
C357	1-164-159-11	(C75ES/C85ES)...CERAMIC	0.1MF		50V
C358	1-164-159-11	(C75ES/C85ES)...CERAMIC	0.1MF		50V
C359	1-164-159-11	CERAMIC	0.1MF		50V
C360	1-162-294-31	(C705)...CERAMIC	1000PF	10%	50V
C361	1-164-159-11	(C75ES/C85ES)...CERAMIC	0.1MF		50V
C362	1-124-120-11	(C705)...ELECT	220MF	20%	16V
C362	1-126-024-11	(C75ES/C85ES)...ELECT	220MF	20%	16V
C363	1-124-120-11	(C705)...ELECT	220MF	20%	16V
C363	1-126-024-11	(C75ES/C85ES)...ELECT	220MF	20%	16V
C364	1-123-333-00	(C75ES/C85ES)...ELECT	100MF	20%	16V
C364	1-162-294-31	(C705)...CERAMIC	1000PF	10%	50V
C365	1-123-333-00	(C75ES/C85ES)...ELECT	100MF	20%	16V
C366	1-124-910-11	(C705)...ELECT	47MF	20%	50V
C366	1-162-199-31	(C75ES/C85ES)...CERAMIC	10PF	5%	50V
C367	1-124-910-11	(C705)...ELECT	47MF	20%	50V
C367	1-162-199-31	(C75ES/C85ES)...CERAMIC	10PF	5%	50V
C368	1-162-203-31	(C705)...CERAMIC	15PF	5%	50V
C368	1-162-294-31	(C75ES/C85ES)...CERAMIC	0.001MF	10%	50V
C369	1-162-204-31	(C705)...CERAMIC	16PF	5%	50V
C370	1-161-379-00	(C705)...CERAMIC	10000PF	30%	16V
C380	1-164-159-11	CERAMIC	0.1MF		50V
C381	1-164-159-11	(C75ES/C85ES)...CERAMIC	0.1MF		50V
C383	1-164-159-11	(C75ES/C85ES)...CERAMIC	0.1MF		50V
C384	1-164-159-11	(C75ES/C85ES)...CERAMIC	0.1MF		50V
C401	1-130-495-00	(C75ES/C85ES)...MYLAR	0.1MF	5%	50V
C402	1-130-495-00	(C75ES/C85ES)...MYLAR	0.1MF	5%	50V
C402	1-164-159-11	(C705)...CERAMIC	0.1MF		50V
C403	1-123-345-00	(C75ES/C85ES)...ELECT	100MF	20%	35V
C403	1-164-159-11	(C705)...CERAMIC	0.1MF		50V
C404	1-130-495-00	(C75ES/C85ES)...MYLAR	0.1MF	5%	50V
C404	1-162-293-31	(C705)...CERAMIC	820PF	10%	50V
C405	1-130-467-00	(C75ES/C85ES)...MYLAR	470PF	5%	50V
C405	1-130-489-00	(C705)...MYLAR	0.033MF	5%	50V
C406	1-130-489-00	(C705)...MYLAR	0.033MF	5%	50V
C406	1-162-282-31	(C75ES/C85ES)...CERAMIC	100PF	10%	50V
C407	1-162-282-31	(C75ES/C85ES)...CERAMIC	100PF	10%	50V
C408	1-106-359-00	MYLAR	0.0047MF	5%	50V
C409	1-130-472-00	MYLAR	0.0012MF	5%	50V
C410	1-123-332-00	(C705)...ELECT	47MF	20%	25V
C410	1-124-910-11	(C75ES/C85ES)...ELECT	47MF	20%	50V

Ref.No.	Part No.	Description			
C411	1-162-199-31	CERAMIC	10PF	5%	50V
C412	1-124-995-11	(C75ES/C85ES)...ELECT	220MF	20%	10V
C412	1-126-176-11	(C705)...ELECT	220MF	20%	10V
C451	1-130-495-00	MYLAR	0.1MF	5%	50V
C452	1-130-495-00	MYLAR	0.1MF	5%	50V
C453	1-123-345-00	(C75ES/C85ES)...ELECT	100MF	20%	35V
C454	1-130-495-00	(C75ES/C85ES)...MYLAR	0.1MF	5%	50V
C454	1-162-293-31	(C705)...CERAMIC	820PF	10%	50V
C455	1-130-467-00	(C75ES/C85ES)...MYLAR	470PF	5%	50V
C455	1-130-489-00	(C705)...MYLAR	0.033MF	5%	50V
C456	1-130-489-00	(C705)...MYLAR	0.033MF	5%	50V
C456	1-162-282-31	(C75ES/C85ES)...CERAMIC	100PF	10%	50V
C457	1-162-282-31	(C75ES/C85ES)...CERAMIC	100PF	10%	50V
C458	1-106-359-00	MYLAR	0.0047MF	5%	50V
C459	1-130-472-00	MYLAR	0.0012MF	5%	50V
C460	1-123-332-00	(C705)...ELECT	47MF	20%	25V
C460	1-124-910-11	(C75ES/C85ES)...ELECT	47MF	20%	50V
C461	1-162-199-31	CERAMIC	10PF	5%	50V
C462	1-124-995-11	(C75ES/C85ES)...ELECT	220MF	20%	10V
C462	1-126-176-11	(C705)...ELECT	220MF	20%	10V
C701	1-162-290-31	CERAMIC	470PF	10%	50V
C702	1-162-290-31	CERAMIC	470PF	10%	50V
C703	1-164-159-11	CERAMIC	0.1MF		50V
C704	1-161-375-00	CERAMIC	0.0022MF	30%	16V
C705	1-161-375-00	CERAMIC	0.0022MF	30%	16V
C801	1-126-177-11	ELECT	100MF	20%	6.3V
C802	1-136-153-00	FILM	0.01MF	5%	50V
C803	1-164-159-11	CERAMIC	0.1MF		50V
C804	1-136-165-00	FILM	0.1MF	5%	50V
C901	1-126-017-11	ELECT	6800MF	20%	16V
C902	1-126-937-11	ELECT	4700MF	20%	16V
C903	1-123-875-11	ELECT	10MF	20%	50V
C904	1-124-927-11	ELECT	4.7MF	20%	50V
C905	1-124-927-11	ELECT	4.7MF	20%	50V
C906	1-161-379-00	CERAMIC	0.01MF	30%	16V
C907	1-126-013-11	ELECT	1000MF	20%	16V
C908	1-126-012-11	ELECT	470MF	20%	16V
C909	1-125-622-11	DOUBLA LAYERS	0.1F		
C910	1-124-572-11	ELECT	100MF	20%	63V
C911	1-124-122-11	ELECT	100MF	20%	50V
C912	1-124-927-11	ELECT	4.7MF	20%	50V
C913	1-161-379-00	CERAMIC	0.01MF	30%	16V
C914	1-161-379-00	CERAMIC	0.01MF	30%	16V
C915	1-126-012-11	ELECT	470MF	20%	16V
C916	1-126-012-11	ELECT	470MF	20%	16V
CN101	1-568-796-11	SOCKET, CONNECTOR	22P		
CN102	1-568-795-11	SOCKET, CONNECTOR	12P		
CN300	1-568-468-11	SOCKET, CONNECTOR	18P		
CN301	1-506-615-11	(C85ES)...PIN, CONNECTOR	9P		
CN301	1-564-500-11	(C75ES/C705)...PIN, CONNECTOR	7P		
CN302	1-564-501-11	PIN, CONNECTOR	8P		
CN303	*1-564-508-11	PLUG, CONNECTOR	5P		
CN306	1-566-211-11	(C85ES)...PIN, CONNECTOR	4P (CONTROL S)		

Ref.No.	Part No.	Description
CN351	*1-564-506-11	PLUG, CONNECTOR 3P
CN353	*1-564-506-11	PLUG, CONNECTOR 3P
CN355	*1-564-509-11	PLUG, CONNECTOR 6P
CN701	*1-564-518-11	PLUG, CONNECTOR 3P
CN702	*1-564-499-11	PIN, CONNECTOR 6P
CN703	*1-564-722-11	PIN, CONNECTOR (SMALL TYPE) 6P
CN704	*1-565-302-11	PIN, CONNECTOR (PC BOARD) 6P
CN705	*1-566-214-11	PIN, CONNECTOR (PC BOARD) 2P
CN706	*1-566-824-11	PIN, CONNECTOR (PC BOARD) 3P
CN805	*1-566-824-11	PIN, CONNECTOR (PC BOARD) 3P
CN807	*1-569-749-11	PIN, CONNECTOR (PC BOARD) 7P
CN809	*1-565-302-11	PIN, CONNECTOR (PC BOARD) 6P
CN901	*1-564-321-00	PIN, CONNECTOR 2P
D301	8-719-107-94	(C85ES)...DIODE 1SS202-1
D302	8-719-107-94	(C85ES)...DIODE 1SS202-1
D303	8-719-109-87	(C85ES)...DIODE RD5.6ES-B1
D351	8-719-107-94	DIODE 1SS202-1
D352	8-719-114-29	(C75ES/C85ES)...DIODE RD5.1JS-B1
D353	1-807-913-21	(C75ES/C85ES)...DIODE 11EQS04
D401	8-719-107-94	(C75ES/C85ES)...DIODE 1SS202-1
D451	8-719-107-94	(C75ES/C85ES)...DIODE 1SS202-1
D701	8-719-970-19	DIODE GP1A521
D801	8-719-107-94	DIODE 1SS202-1
D802	8-719-107-94	DIODE 1SS202-1
D803	8-719-107-94	DIODE 1SS202-1
D804	8-719-107-94	DIODE 1SS202-1
D805	8-719-107-94	DIODE 1SS202-1
D806	8-719-107-94	DIODE 1SS202-1
D810	8-719-907-75	DIODE AA55345 (■)
D811	8-719-907-81	DIODE BG55355 (▶)
D901	8-719-200-77	DIODE 10E2N
D902	8-719-200-77	DIODE 10E2N
D903	8-719-200-77	DIODE 10E2N
D904	8-719-200-77	DIODE 10E2N
D905	8-719-200-77	DIODE 10E2N
D906	8-719-109-87	DIODE RD5.6ES-B
D907	8-719-107-94	DIODE 1SS202-1
D908	8-719-107-94	DIODE 1SS202-1
D909	8-719-107-94	DIODE 1SS202-1
D910	8-719-107-94	DIODE 1SS202-1
D911	8-719-107-94	DIODE 1SS202-1
D912	8-719-107-94	DIODE 1SS202-1
D913	8-719-109-87	DIODE RD5.6ES-B
D914	8-719-107-94	DIODE 1SS202-1
D915	8-719-107-94	DIODE 1SS202-1
D916	8-719-107-94	(C75ES/C85ES)...DIODE 1SS202-1
FL801	1-519-584-11	INDICATOR TUBE, FLUORESCENT
IC101	8-752-037-33	IC CXA1372Q
IC102	8-759-821-94	IC LA6532M-T1
IC301	8-752-333-31	IC CXD2500Q
IC302	8-759-149-42	IC UPD75512GF-034-3B9
IC303	8-759-822-77	IC LC3564PML-15
IC304	8-752-035-28	IC CXA-1291P
IC305	8-759-977-71	IC GP1F31T (DIGITAL OUT)
IC351	8-752-337-09	IC CXD2554P
IC352	8-759-605-44	(C705).....IC M74HC6004P
IC352	8-759-917-18	(C75ES/C85ES)...IC SN74HCU04N

Ref.No.	Part No.	Description
IC353	8-752-334-77	(C75ES/C85ES)...IC CXD2553S
IC354	8-752-334-87	(C75ES/C85ES)...IC CXD2552Q
IC355	8-759-981-85	(C75ES/C85ES)...IC RC4556D
IC356	8-759-604-86	(C75ES/C85ES)...IC M5F7807
IC401	8-759-982-03	(C75ES/C85ES)...IC RC5532DD
IC401	8-759-989-83	(C705).....IC AD1860N-K
IC402	8-749-982-03	(C705)...IC RC5532DD
IC451	8-759-982-03	(C75ES/C85ES)...IC RC5532DD
IC451	8-759-939-83	(C705).....IC AD1860N-K
IC452	8-749-982-03	(C705)...IC RC5532DD
IC801	8-759-500-57	IC MSC62408-009GS-K
IC802	8-749-920-83	IC GP1U52XB
IC900	8-759-630-21	IC M5290P-16
IC901	8-759-605-43	IC M5231TL
IC902	8-759-604-86	IC M5F7807
J101	1-216-295-00	METAL GLAZE 0 5% 1/10W
J102	1-216-295-00	METAL GLAZE 0 5% 1/10W
J351	1-568-760-11	(C75ES/C85ES)...JACK, PIN 4P(LINE OUT)
J351	1-568-761-11	(C705).....JACK, PIN 4P(LINE OUT)
J701	1-568-519-11	(C705)...JACK, LARGE TYPE (HEADPHONES)
J701	1-568-519-31	(C75ES/C85ES) ...JACK, LARGE TYPE (HEADPHONES)
L351	*1-410-858-11	INDICATOR OUH
M1	X-4917-523-3	MOTOR ASSY, SPINDLE
M2	X-4917-504-1	MOTOR ASSY, SLED
M701	A-4604-585-A	MOTOR ASSY, ROTARY
M702	A-4604-528-A	MOTOR ASSY, LOADING
Q101	8-729-901-01	TRANSISTOR DTC144EK
Q302	8-729-900-89	TRANSISTOR DTC144ES
Q303	8-729-900-61	TRANSISTOR DTA114ES
Q304	8-729-900-61	TRANSISTOR DTA114ES
Q305	8-729-900-61	TRANSISTOR DTA114ES
Q351	8-729-900-61	TRANSISTOR DTA114ES
Q352	8-729-216-13	(C75ES/C85ES)...TRANSISTOR 2SK161GR
Q352	8-729-900-89	(C705).....TRANSISTOR DTC144ES
Q353	8-729-140-96	(C75ES/C85ES)...TRANSISTOR 2SD774-34
Q401	8-729-107-99	TRANSISTOR 2SC3622A-K
Q402	8-729-107-99	TRANSISTOR 2SC3622A-K
Q403	8-729-107-99	TRANSISTOR 2SC3622A-K
Q404	8-729-900-61	(C75ES/C85ES)...TRANSISTOR DTA114ES
Q405	8-729-900-80	(C75ES/C85ES)...TRANSISTOR DTC114ES
Q451	8-729-107-99	TRANSISTOR 2SC3622A-K
Q452	8-729-107-99	TRANSISTOR 2SC3622A-K
Q453	8-729-107-99	TRANSISTOR 2SC3622A-K
Q454	8-729-900-61	(C75ES/C85ES)...TRANSISTOR DTA114ES
Q455	8-729-900-80	(C75ES/C85ES)...TRANSISTOR DTC114ES
Q801	8-729-900-45	TRANSISTOR DTC114EF
Q802	8-729-900-45	TRANSISTOR DTC114EF
Q803	8-729-900-45	TRANSISTOR DTC114EF
Q804	8-729-900-45	TRANSISTOR DTC114EF
Q901	8-729-111-67	TRANSISTOR 2SB1094-L
Q902	8-729-140-96	(C75ES/C85ES)...TRANSISTOR 2SD774-34
Q902	8-729-177-44	(C705).....TRANSISTOR 2SD774-5
Q903	8-729-900-89	TRANSISTOR DTC144ES
Q904	8-729-900-89	TRANSISTOR DTC144ES
Q905	8-729-900-89	TRANSISTOR DTC144ES

Ref.No.	Part No.	Description				
R101	1-216-097-00	METAL GLAZE	100K	5%	1/10W	
R102	1-216-097-00	METAL GLAZE	100K	5%	1/10W	
R103	1-216-091-00	METAL GLAZE	56K	5%	1/10W	
R104	1-216-099-00	METAL GLAZE	120K	5%	1/10W	
R105	1-216-069-00	METAL GLAZE	6.8K	5%	1/10W	
R106	1-216-061-00	METAL GLAZE	3.3K	5%	1/10W	
R107	1-216-114-00	METAL GLAZE	510K	5%	1/10W	
R108	1-216-105-00	METAL GLAZE	220K	5%	1/10W	
R109	1-216-061-00	METAL GLAZE	3.3K	5%	1/10W	
R110	1-216-049-00	METAL GLAZE	1K	5%	1/10W	
R111	1-216-049-00	METAL GLAZE	1K	5%	1/10W	
R112	1-216-083-00	METAL GLAZE	27K	5%	1/10W	
R113	1-216-071-00	METAL GLAZE	8.2K	5%	1/10W	
R114	1-216-105-00	METAL GLAZE	220K	5%	1/10W	
R152	1-216-073-00	METAL GLAZE	10K	5%	1/10W	
R153	1-216-085-00	METAL GLAZE	33K	5%	1/10W	
R154	1-216-085-00	METAL GLAZE	33K	5%	1/10W	
R155	1-216-093-00	METAL GLAZE	68K	5%	1/10W	
R156	1-216-081-00	METAL GLAZE	22K	5%	1/10W	
R157	1-216-079-00	METAL GLAZE	18K	5%	1/10W	
R158	1-216-079-00	METAL GLAZE	18K	5%	1/10W	
R159	1-216-079-00	METAL GLAZE	18K	5%	1/10W	
R160	1-216-049-00	METAL GLAZE	1K	5%	1/10W	
R171	1-216-001-00	METAL GLAZE	10	5%	1/10W	
R172	1-216-001-00	METAL GLAZE	10	5%	1/10W	
R173	1-216-001-00	METAL GLAZE	10	5%	1/10W	
R174	1-216-001-00	METAL GLAZE	10	5%	1/10W	
R301	1-249-417-11	CARBON	1K	5%	1/4W	
R302	1-249-417-11	CARBON	1K	5%	1/4W	
R303	1-249-417-11	CARBON	1K	5%	1/4W	
R304	1-249-441-11	CARBON	100K	5%	1/4W	
R305	1-249-429-11	CARBON	10K	5%	1/4W	
R306	1-249-423-11	CARBON	3.3K	5%	1/4W	
R307	1-249-423-11	CARBON	3.3K	5%	1/4W	
R308	1-249-429-11	CARBON	10K	5%	1/4W	
R309	1-249-413-11	CARBON	470	5%	1/4W	
R310	1-249-429-11	CARBON	10K	5%	1/4W	
R311	1-249-429-11	CARBON	10K	5%	1/4W	
R312	1-249-429-11	CARBON	10K	5%	1/4W	
R313	1-249-429-11	CARBON	10K	5%	1/4W	
R314	1-249-429-11	CARBON	10K	5%	1/4W	
R315	1-249-429-11	CARBON	10K	5%	1/4W	
R316	1-249-429-11	CARBON	10K	5%	1/4W	
R317	1-249-429-11	CARBON	10K	5%	1/4W	
R318	1-249-429-11	CARBON	10K	5%	1/4W	
R319	1-249-429-11	CARBON	10K	5%	1/4W	
R320	1-249-417-11	CARBON	1K	5%	1/4W	
R321	1-249-417-11	CARBON	1K	5%	1/4W	
R322	1-249-417-11	CARBON	1K	5%	1/4W	
R323	1-249-429-11	CARBON	10K	5%	1/4W	
R324	1-249-429-11	CARBON	10K	5%	1/4W	
R325	1-249-429-11	CARBON	10K	5%	1/4W	
R326	1-249-429-11	CARBON	10K	5%	1/4W	
R327	1-249-429-11	CARBON	10K	5%	1/4W	
R328	1-247-881-00	CARBON	120K	5%	1/4W	
R329	1-249-439-11	CARBON	68K	5%	1/4W	
R330	1-247-881-00	CARBON	120K	5%	1/4W	

Ref.No.	Part No.	Description				
R331	1-249-439-11	CARBON	68K	5%	1/4W	
R332	1-247-880-11	CARBON	110K	5%	1/4W	
R333	1-249-440-11	CARBON	82K	5%	1/4W	
R334	1-249-441-11	CARBON	100K	5%	1/4W	
R335	1-249-440-11	CARBON	82K	5%	1/4W	
R336	1-247-878-00	CARBON	91K	5%	1/4W	
R337	1-247-878-00	CARBON	91K	5%	1/4W	
R338	1-249-440-11	CARBON	82K	5%	1/4W	
R339	1-249-440-11	CARBON	82K	5%	1/4W	
R340	1-249-393-11	CARBON	10	5%	1/4W	
R341	1-249-393-11	CARBON	10	5%	1/4W	
R342	1-249-393-11	CARBON	10	5%	1/4W	
R343	1-249-410-11	CARBON	270	5%	1/4W	
R344	1-249-429-11	(C85ES).....CARBON	10K	5%	1/4W	
R345	1-249-393-11	(C85ES).....CARBON	10	5%	1/4W	
R346	1-249-429-11	(C85ES).....CARBON	10K	5%	1/4W	
R349	1-249-417-11	(C75ES/C85ES)...CARBON	1K	5%	1/4W	
R351	1-249-439-11	(C75ES/C85ES)...CARBON	68K	5%	1/4W	
R353	1-249-415-11	(C75ES/C85ES)...CARBON	680	5%	1/4W	
R354	1-247-848-11	(C75ES/C85ES)...CARBON	5.1K	5%	1/4W	
R354	1-249-417-11	(C705).....CARBON	1K	5%	1/4W	
R355	1-249-393-11	(C705).....CARBON	10	5%	1/4W	
R355	1-249-415-11	(C75ES/C85ES)...CARBON	680	5%	1/4W	
R356	1-247-903-00	(C75ES/C85ES)...CARBON	1M	5%	1/4W	
R356	1-249-417-11	(C705).....CARBON	1K	5%	1/4W	
R357	1-249-413-11	(C705).....CARBON	470	5%	1/4W	
R357	1-249-414-11	(C75ES/C85ES)...CARBON	560	5%	1/4W	
R358	1-249-393-11	(C705).....CARBON	10	5%	1/4W	
R358	1-249-415-11	(C75ES/C85ES)...CARBON	680	5%	1/4W	
R359	1-247-826-00	(C705).....CARBON	620	5%	1/4W	
R359	1-249-415-11	(C75ES/C85ES)...CARBON	680	5%	1/4W	
R360	1-247-826-00	(C705).....CARBON	620	5%	1/4W	
R360	1-249-415-11	(C75ES/C85ES)...CARBON	680	5%	1/4W	
R361	1-247-826-00	(C705).....CARBON	620	5%	1/4W	
R361	1-249-415-11	(C75ES/C85ES)...CARBON	680	5%	1/4W	
R362	1-247-700-11	CARBON	100	5%	1/4W	
R363	1-247-700-11	CARBON	100	5%	1/4W	
R364	1-249-405-11	(C75ES/C85ES)...CARBON	100	5%	1/4W	
R364	1-249-417-11	(C705).....CARBON	1K	5%	1/4W	
R380	1-249-417-11	(C75ES/C85ES)...CARBON	1K	5%	1/4W	
R401	1-215-444-00	(C75ES/C85ES)...METAL	9.1K	1%	1/6W	
R402	1-215-444-00	(C75ES/C85ES)...METAL	9.1K	1%	1/6W	
R403	1-215-433-00	(C75ES/C85ES)...METAL	3.3K	1%	1/6W	
R404	1-215-433-00	(C75ES/C85ES)...METAL	3.3K	1%	1/6W	
R405	1-215-451-00	(C75ES/C85ES)...METAL	18K	1%	1/6W	
R406	1-215-451-00	(C75ES/C85ES)...METAL	18K	1%	1/6W	
R406	1-249-409-11	(C705).....CARBON	220	5%	1/4W	
R407	1-249-419-11	(C705).....CARBON	1.5K	5%	1/4W	
R407	1-249-420-11	(C75ES/C85ES)...CARBON	1.8K	5%	1/4W	
R408	1-249-419-11	(C705).....CARBON	1.5K	5%	1/4W	
R408	1-249-420-11	(C75ES/C85ES)...CARBON	1.8K	5%	1/4W	
R409	1-247-891-00	(C705).....CARBON	330K	5%	1/4W	
R409	1-249-409-11	(C75ES/C85ES)...CARBON	220	5%	1/4W	

Ref.No.	Part No.	Description					
R410	1-249-423-11	CARBON	3.3K	5%	1/4W		
R411	1-249-423-11	CARBON	3.3K	5%	1/4W		
R412	1-249-405-11	CARBON	100	5%	1/4W		
R413	1-249-405-11	(C75ES/C85ES)...CARBON	100	5%	1/4W		
R414	1-249-405-11	CARBON	100	5%	1/4W		
R415	1-249-434-11	(C705).....CARBON	27K	5%	1/4W		
R415	1-249-435-11	(C75ES/C85ES)...CARBON	33K	5%	1/4W		
R416	1-249-437-11	(C705).....CARBON	47K	5%	1/4W		
R416	1-249-439-11	(C75ES/C85ES)...CARBON	68K	5%	1/4W		
R417	1-249-439-11	(C75ES/C85ES)...CARBON	68K	5%	1/4W		
R417	1-249-441-11	(C705).....CARBON	400K	5%	1/4W		
R418	1-247-800-11	(C705).....CARBON	51	5%	1/4W		
R418	1-249-402-11	(C75ES/C85ES)...CARBON	56	5%	1/4W		
R419	1-249-421-11	CARBON	2.2K	5%	1/4W		
R420	1-249-405-11	(C705).....CARBON	100	5%	1/4W		
R420	1-249-441-11	(C75ES/C85ES)...CARBON	100K	5%	1/4W		
R451	1-215-444-00	(C75ES/C85ES)...METAL	9.1K	1%	1/6W		
R452	1-215-444-00	(C75ES/C85ES)...METAL	9.1K	1%	1/6W		
R453	1-215-433-00	(C75ES/C85ES)...METAL	3.3K	1%	1/6W		
R454	1-215-433-00	(C75ES/C85ES)...METAL	3.3K	1%	1/6W		
R455	1-215-451-00	(C75ES/C85ES)...METAL	18K	1%	1/6W		
R456	1-215-451-00	(C75ES/C85ES)...METAL	18K	1%	1/6W		
R456	1-249-409-11	(C705).....CARBON	220	5%	1/4W		
R457	1-249-419-11	(C705).....CARBON	1.5K	5%	1/4W		
R457	1-249-420-11	(C75ES/C85ES)...CARBON	1.8K	5%	1/4W		
R458	1-249-419-11	(C705).....CARBON	1.5K	5%	1/4W		
R458	1-249-420-11	(C75ES/C85ES)...CARBON	1.8K	5%	1/4W		
R459	1-247-891-00	(C705).....CARBON	330K	5%	1/4W		
R459	1-249-409-11	(C75ES/C85ES)...CARBON	220	5%	1/4W		
R460	1-249-423-11	CARBON	3.3K	5%	1/4W		
R461	1-249-423-11	CARBON	3.3K	5%	1/4W		
R462	1-249-405-11	CARBON	100	5%	1/4W		
R463	1-249-405-11	(C75ES/C85ES)...CARBON	100	5%	1/4W		
R464	1-249-405-11	CARBON	100	5%	1/4W		
R465	1-249-434-11	(C705).....CARBON	27K	5%	1/4W		
R465	1-249-435-11	(C75ES/C85ES)...CARBON	33K	5%	1/4W		
R466	1-249-437-11	(C705).....CARBON	47K	5%	1/4W		
R466	1-249-439-11	(C75ES/C85ES)...CARBON	68K	5%	1/4W		
R467	1-249-439-11	(C75ES/C85ES)...CARBON	68K	5%	1/4W		
R467	1-249-441-11	(C705).....CARBON	400K	5%	1/4W		
R468	1-247-800-11	(C705).....CARBON	51	5%	1/4W		
R468	1-249-402-11	(C75ES/C85ES)...CARBON	56	5%	1/4W		
R469	1-249-421-11	CARBON	2.2K	5%	1/4W		
R470	1-249-405-11	(C705).....CARBON	100	5%	1/4W		
R470	1-249-441-11	(C75ES/C85ES)...CARBON	100K	5%	1/4W		
R701	1-249-416-11	CARBON	820	5%	1/4W		
R801	1-249-441-11	CARBON	100K	5%	1/4W		
R802	1-249-441-11	CARBON	100K	5%	1/4W		
R803	1-249-406-11	CARBON	120	5%	1/4W		
R804	1-249-409-11	CARBON	220	5%	1/4W		
R805	1-249-429-11	CARBON	10K	5%	1/4W		
R806	1-249-417-11	CARBON	1K	5%	1/4W		
R807	1-249-429-11	CARBON	10K	5%	1/4W		
R808	1-247-903-00	CARBON	1M	5%	1/4W		
R901	1-249-425-11	CARBON	4.7K	5%	1/4W		
R902	1-249-425-11	CARBON	4.7K	5%	1/4W		
R903	△.1-212-849-00	FUSIBLE	4.7	5%	1/4W	F	
R904	1-249-423-11	CARBON	3.3K	5%	1/4W		
R905	1-249-399-11	CARBON	33	5%	1/4W		
R906	1-249-429-11	CARBON	10K	5%	1/4W		
R907	1-249-439-11	CARBON	68K	5%	1/4W		
R908	1-249-423-11	CARBON	3.3K	5%	1/4W		
R909	1-249-417-11	CARBON	1K	5%	1/4W		
R910	1-249-429-11	CARBON	10K	5%	1/4W		
R911	1-249-433-11	CARBON	22K	5%	1/4W		
R912	1-249-433-11	CARBON	22K	5%	1/4W		
R914	1-249-410-11	CARBON	270	5%	1/4W		
R915	1-249-441-11	(C705)...CARBON	100K	5%	1/4W		
RV101	1-238-016-11	RES, ADJ, CARBON	10K		(TRACKING GAIN)		
RV102	1-238-016-11	RES, ADJ, CARBON	10K		(FOCUS GAIN)		
RV701	1-241-129-11	RES, VAR, CARBON	10KX3		(LEVEL)		
S101	1-572-085-11	SWITCH, LEAF	(LIMIT S1)				
S701	1-572-379-11	SWITCH, PUSH					
S702	1-571-300-11	SWITCH, ROTARY					
S703	1-570-157-21	SWITCH, SLIDE	(TIMER)				
S801	1-554-303-21	SWITCH, KEY BOARD	(4)				
S802	1-554-303-21	SWITCH, KEY BOARD	(BAND)				
S803	1-554-303-21	SWITCH, KEY BOARD	(ERASE)				
S804	1-554-303-21	SWITCH, KEY BOARD	(☛ OPEN/CLOSE)				
S805	1-554-303-21	SWITCH, KEY BOARD	(FILE)				
S811	1-554-303-21	SWITCH, KEY BOARD	(2)				
S812	1-554-303-21	SWITCH, KEY BOARD	(CONTINUE)				
S813	1-554-303-21	SWITCH, KEY BOARD	(■)				
S814	1-554-303-21	SWITCH, KEY BOARD	(◄◄)				
S815	1-554-303-21	(C85ES)...SWITCH, KEY BOARD	(4)				
S816	1-554-303-21	SWITCH, KEY BOARD	(FADER)				
S817	1-554-303-21	(C85ES)...SWITCH, KEY BOARD	(9)				
S821	1-554-303-21	SWITCH, KEY BOARD	(MUSIC SCAN)				
S822	1-554-303-21	SWITCH, KEY BOARD	(TIME)				
S823	1-554-303-21	SWITCH, KEY BOARD	(►)				
S824	1-554-303-21	SWITCH, KEY BOARD	(◄◄)				
S825	1-554-303-21	(C85ES)...SWITCH, KEY BOARD	(5)				
S826	1-554-303-21	SWITCH, KEY BOARD	(■■)				
S827	1-554-303-21	(C85ES)...SWITCH, KEY BOARD	(10)				
S831	1-554-303-21	SWITCH, KEY BOARD	(3)				
S832	1-554-303-21	SWITCH, KEY BOARD	(PROGRAM)				
S833	1-554-303-21	SWITCH, KEY BOARD	(CHECK)				
S834	1-554-303-21	SWITCH, KEY BOARD	(DISK SKIP)				
S835	1-554-303-21	(C85ES)...SWITCH, KEY BOARD	(3)				
S836	1-554-303-21	SWITCH, KEY BOARD	(LEVEL FILE)				
S837	1-554-303-21	(C85ES)...SWITCH, KEY BOARD	(8)				
S841	1-554-303-21	SWITCH, KEY BOARD	(1)				
S842	1-554-303-21	SWITCH, KEY BOARD	(SHUFFLE)				
S843	1-554-303-21	SWITCH, KEY BOARD	(CLEAR)				
S844	1-554-303-21	SWITCH, KEY BOARD	(■)				
S845	1-554-303-21	(C85ES)...SWITCH, KEY BOARD	(2)				
S846	1-554-303-21	SWITCH, KEY BOARD	(PEAK SEARCH)				

Note:

The components identified by mark △ or dotted line with mark △ are critical for safety. Replace only with part number specified.



Note:

Les composants identifiés par une marque △ sont critiques pour la sécurité. Ne les remplacer que par une pièce portant le numéro spécifié.

Ref.No.	Part No.	Description
S847	1-554-303-21	(C85ES)...SWITCH, KEY BOARD (7)
S851	1-554-303-21	SWITCH, KEY BOARD (5)
S852	1-554-303-21	SWITCH, KEY BOARD (REPEAT)
S853	1-554-303-21	(C85ES)...SWITCH, KEY BOARD (>10)
S854	1-554-303-21	SWITCH, KEY BOARD (
S855	1-554-303-21	(C85ES)...SWITCH, KEY BOARD (1)
S856	1-554-303-21	SWITCH, KEY BOARD (TIME FADE)
S857	1-554-303-21	(C85ES)...SWITCH, KEY BOARD (6)
S901	1-571-305-11	SWITCH, PUSH (1 KEY)(POWER)
SW901	1-571-722-11	(E)...SWITCH, VOLTAGE SELECTOR
T901	△.1-450-133-11	(US,Canadian).....TRANSFORMER, POWER
T901	△.1-450-134-11	(AEP,Australian)...TRANSFORMER, POWER
T901	△.1-450-135-11	(E).....TRANSFORMER, POWER
X301	1-577-359-21	VIBRATOR, CERAMIC 4.19MHZ
X351	1-567-926-11	(C705)...VIBRATOR, CRYSTAL 16.9344MHZ
X351	1-577-685-11	(C75ES/C85ES) ...FILTER, CRYSTAL 16.9344MHZ
X352	1-577-686-11	(C75ES/C85ES)...VIBRATOR, CRYSTAL 45.15MHZ
X801	1-577-358-21	VIBRATOR, CERAMIC 4MHZ

ACCESSORY & PACKING MATERIAL

1-465-400-11	COMMANDER, REMOTE (RM-D706)
1-558-271-11	(C75ES/C85ES)...CORD, CONNECTION
1-559-533-11	(C705).....CORD, CONNECTION
3-704-366-01	(C85ES)...SCREW (CASE) (M3X8)
3-707-584-01	COVER, BATTERY
3-751-839-11	(C705:Canadian,AEP,E,Australian) ...MANUAL, INSTRUCTION
3-751-839-21	(C705:US).....MANUAL, INSTRUCTION
3-751-839-41	(C705:AEP).....MANUAL, INSTRUCTION
3-751-867-21	(C75ES/C85ES).....MANUAL, INSTRUCTION
*3-759-629-15	(C705:AEP)...INSTRUCTION
*4-930-586-01	(C75ES/C705)...CUSHION (FRONT)
*4-930-587-01	(C75ES/C705)...CUSHION (REAR)
*4-934-320-01	(C85ES)...CUSHION (FRONT)
*4-934-321-01	(C85ES)...CUSHION (REAR)
*4-937-953-01	(C85ES).....INDIVIDUAL CARTON
*4-937-954-11	(C75ES/C705)...INDIVIDUAL CARTON

Note:
The components identified by mark  or dotted line with mark  are critical for safety. Replace only with part number specified.

Note:
Les composants identifiés par une marque  sont critiques pour la sécurité. Ne les remplacer que par une pièce portant le numéro spécifié.

CDP-C75ES/C85ES/C705

SONY[®] SERVICE MANUAL

US Model
Canadian Model
CDP-C75ES

US Model
E Model
CDP-C85ES

US Model
Canadian Model
AEP Model
E Model
Australian Model
CDP-C705

CORRECTION-1

Correct your service manual as shown below.

 : indicates corrected portion.

Page	INCORRECT	CORRECT
8	<p>E-F Balance Check Procedure :</p> <p>1. Connect test point TP (ADJ) and TP (TES) to ground with lead wire.</p>	<p>E-F Balance Check Procedure :</p> <p>1. Connect test point TP (ADJ) to ground and TP (TES) to TP (VC) with lead wire.</p> <p>Adjustment Location : 【BD board】</p> 