

CDP-C250Z/C350Z/CE305/CE405

SERVICE MANUAL

US Model
CDP-C250Z/C350Z/CE305/CE405

Canadian Model

AEP Model
CDP-CE305/CE405

UK Model
CDP-CE405

Australian Model

E Model

Chinese Model
CDP-CE305/CE405



Photo : CDP-CE405

Model Name Using Similar Mechanism	CDP-C265/C365
CD Mechanism Type	CDM27A2-5BD20
Base Unit Type	BU-5BD20
Optical Pick-up Type	KSS-213B/K-N

SPECIFICATIONS

Compact Disc Player

Laser	Semiconductor laser ($\lambda = 780 \text{ nm}$) Emission duration: continuous
Laser output	Max 44.6 μW * *This output is the value measured at a distance of 200 mm from the objective lens surface on the Optical Pick-up block with 7 mm aperture.
Frequency response	2 Hz to 20 kHz $\pm 0.5 \text{ dB}$
Signal-to-noise ratio	More than 102 dB
Dynamic range	More the 98 dB
Harmonic distortion	Less than 0.0045%
Channel separation	More than 100 dB

Output

	Jack type	Maximum output level	Load impedance
LINE OUT	Phono jacks	2V (at 50 kilohms)	Over 10 kilohms

General

Power requirements

Where purchased	Power requirements
US, Canadian	120V AC, 60 Hz
AEP, UK, German, Italian, East European	220-230V AC, 50/60 Hz
Australian	240V AC, 50/60 Hz
E	110-120V, 220-240V adjustable, 50/60 Hz
Chinese	220-240V AC, 50 Hz

Power consumption	14W
Dimensions (approx.) (w/h/d)	430 \times 120 \times 385 mm (17 \times 4 3/4 \times 15 1/4 in.) incl. projecting parts
Mass (approx.)	5.6 kg (12 lbs 6 oz)

Supplied accessories

Audio cord (2 phono plugs-2 phono plugs) (1)
Remote commander (remote) (CDP-C350Z/CE405 only)
Sony SUM-3 (NS) batteries (CDP-C350Z/CE405 only)
AC plug adaptor (1) (E model only)

Design and specifications are subject to change without notice.



COMPACT DISC PLAYER
SONY[®]

The following caution label is located inside of the unit.

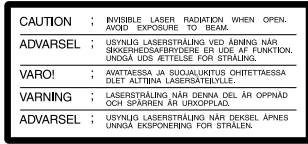

This appliance is classified as a CLASS 1 LASER product. The CLASS 1 LASER PRODUCT MARKING is located on the rear exterior.

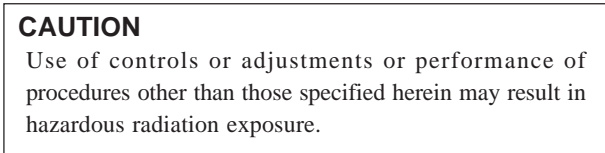

TABLE OF CONTENTS

<u>Section</u>	<u>Title</u>	<u>Page</u>
SECTION 1. GENERAL		5
SECTION 2. DISASSEMBLY		
2-1.	Case, Bottom Plate and Front Panel	6
2-2.	Back Panel and Disc Table	6
2-3.	Optical Pick-up Block Assembly	7
2-4.	Bracket (Gear) Assembly	7
SECTION 3. ELECTRICAL BLOCK CHECKING		8
SECTION 4. DIAGRAMS		
4-1.	Circuit Boards Location	10
4-2.	Printed Wiring Board — BD Section —	11
4-3.	Schematic Diagram — BD Section —	13
4-4.	IC Block Diagrams	15
4-5.	Printed Wiring Board — Main Section —	17
4-6.	Schematic Diagram — Main Section —	21
4-7.	IC Pin Functions	
	• IC101 Digital Signal Processor (CXD2545Q)	24
	• IC303 System Control (CXP82320-064Q)	27
SECTION 5. EXPLODED VIEWS		
5-1.	Front Panel and Case Section	28
5-2.	Back Panel and Disk Table Section	29
5-3.	Chassis Section	30
5-4.	Base Unit Section (BU-5BD20)	31
SECTION 6. ELECTRICAL PARTS LIST		32

SAFETY-RELATED COMPONENT WARNING !!

COMPONENTS IDENTIFIED BY MARK \triangle OR DOTTED LINE WITH MARK \triangle ON THE SCHEMATIC DIAGRAMS AND IN THE PARTS LIST ARE CRITICAL TO SAFE OPERATION. REPLACE THESE COMPONENTS WITH SONY PARTS WHOSE PART NUMBERS APPEAR AS SHOWN IN THIS MANUAL OR IN SUPPLEMENTS PUBLISHED BY SONY.

ATTENTION AU COMPOSANT AYANT RAPPORT À LA SÉCURITÉ!!

LES COMPOSANTS IDENTIFIÉS PAR UNE MARQUE \triangle SUR LES DIAGRAMMES SCHÉMATIQUES ET LA LISTE DES PIÈCES SONT CRITIQUES POUR LA SÉCURITÉ DE FONCTIONNEMENT. NE REMPLACER CES COMPOSANTS QUE PAR DES PIÈCES SONY DONT LES NUMÉROS SONT DONNÉS DANS CE MANUEL OU DANS LES SUPPLÉMENTS PUBLIÉS PAR SONY.

MODEL IDENTIFICATION
— BACK PANEL —

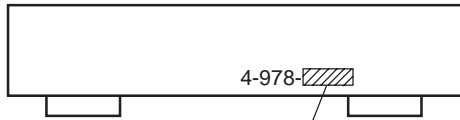

CDP-C250Z	
US Model	: 490-7□
CDP-C350Z	
US Model	: 490-8□
CDP-CE305	
US Model	: 490-0□
Canadian Model	: 490-1□
AEP Model	: 767-2□
German Model	: 490-3□
Australian Model	: 490-4□
E Model	: 490-5□
Chinese Model	: 490-6□
CDP-CE405	
US Model	: 767-0□
Canadian Model	: 767-1□
AEP, East European,	
Chinese Model	: 767-2□
UK Model	: 767-4□
German Model	: 767-3□
E Model	: 767-6□
Australian Model	: 767-5□

NOTES ON HANDLING THE OPTICAL PICK-UP BLOCK OR BASE UNIT

The laser diode in the optical pick-up block may suffer electrostatic breakdown because of the potential difference generated by the charged electrostatic load, etc. on clothing and the human body.

During repair, pay attention to electrostatic breakdown and also use the procedure in the printed matter which is included in the repair parts.

The flexible board is easily damaged and should be handled with care.

NOTES ON LASER DIODE EMISSION CHECK

The laser beam on this model is concentrated so as to be focused on the disc reflective surface by the objective lens in the optical pick-up block. Therefore, when checking the laser diode emission, observe from more than 30 cm away from the objective lens.

SAFETY CHECK-OUT
(US model only)

After correcting the original service problem, perform the following safety checks before releasing the set to the customer: Check the antenna terminals, metal trim, “metallized” knobs, screws, and all other exposed metal parts for AC leakage. Check leakage as described below.

LEAKAGE

The AC leakage from any exposed metal part to earth ground and from all exposed metal parts to any exposed metal part having a return to chassis, must not exceed 0.5 mA (500 microamperes). Leakage current can be measured by any one of three methods.

1. A commercial leakage tester, such as the Simpson 229 or RCA WT-540A. Follow the manufacturers’ instructions to use these instruments.
2. A battery-operated AC milliammeter. The Data Precision 245 digital multimeter is suitable for this job.
3. Measuring the voltage drop across a resistor by means of a VOM or battery-operated AC voltmeter. The “limit” indication is 0.75 V, so analog meters must have an accurate low-voltage scale. The Simpson 250 and Sanwa SH-63Trd are examples of a passive VOM that is suitable. Nearly all battery operated digital multimeters that have a 2V AC range are suitable. (See Fig. A)

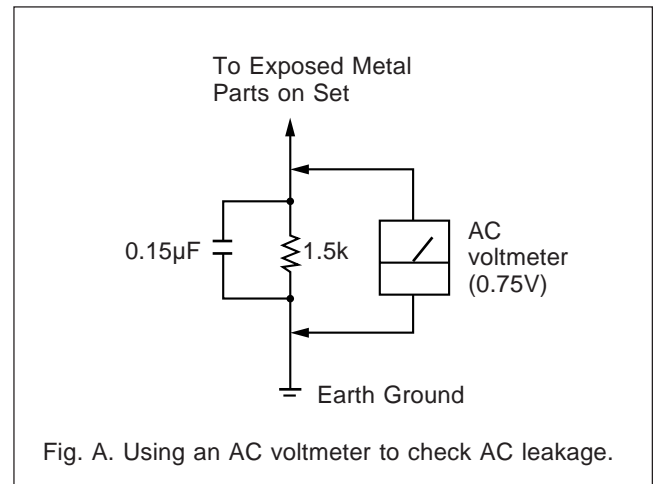
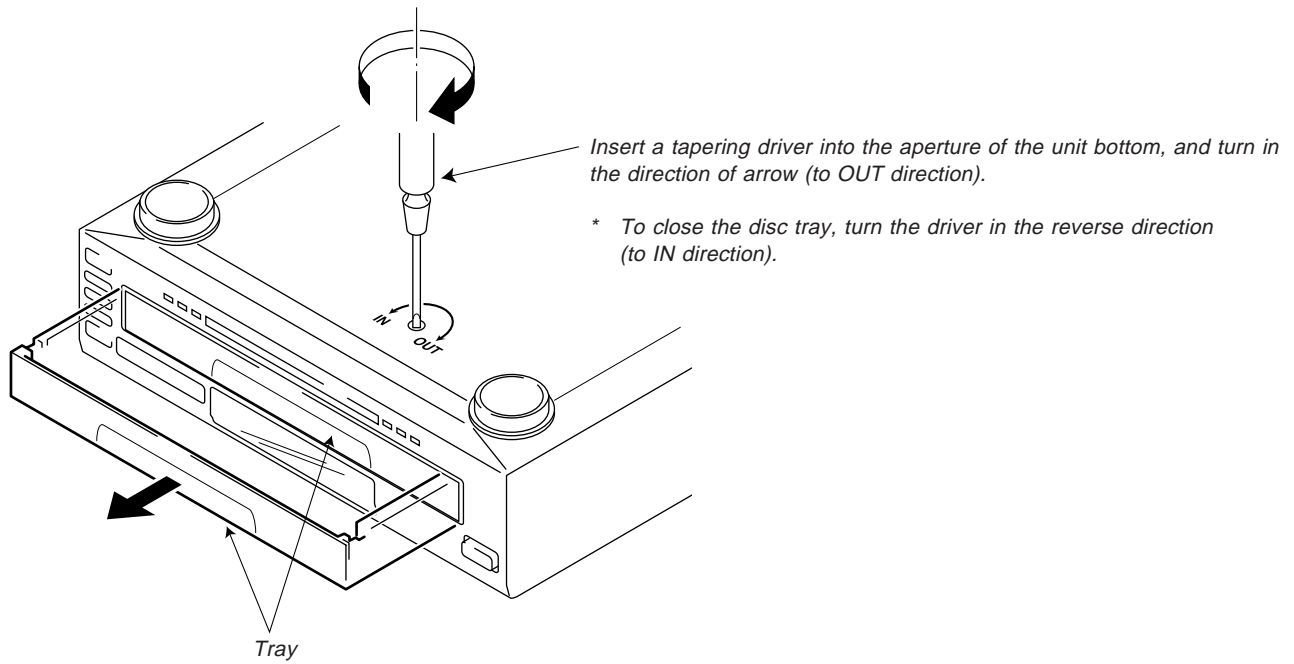
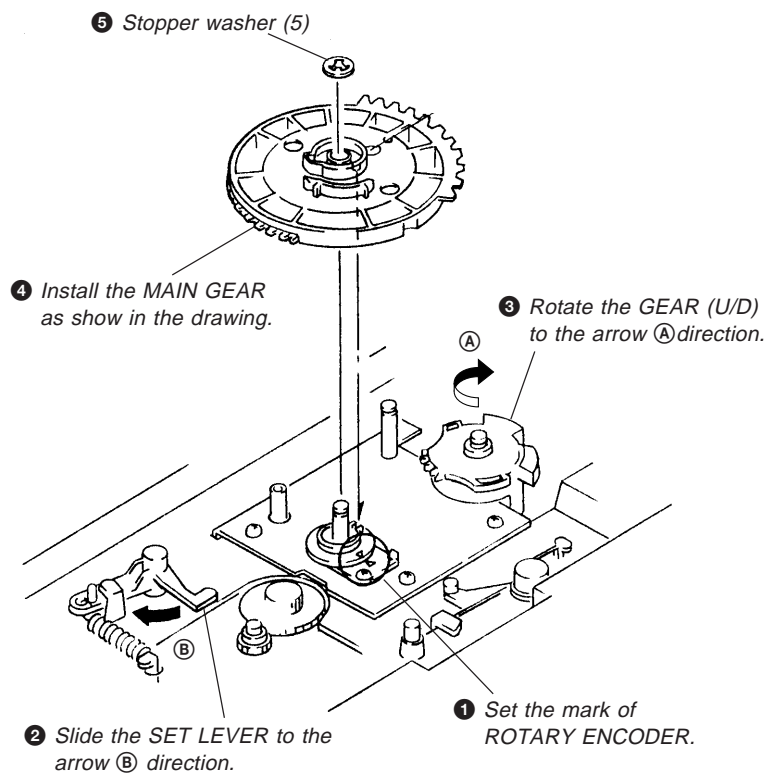

Fig. A. Using an AC voltmeter to check AC leakage.

HOW TO OPEN THE DISC TRAY WHEN POWER SWITCH TURNS OFF



NOTE FOR MAIN GAER INSTALLATION



SECTION 1

GENERAL

Identifying the Parts

Front Panel

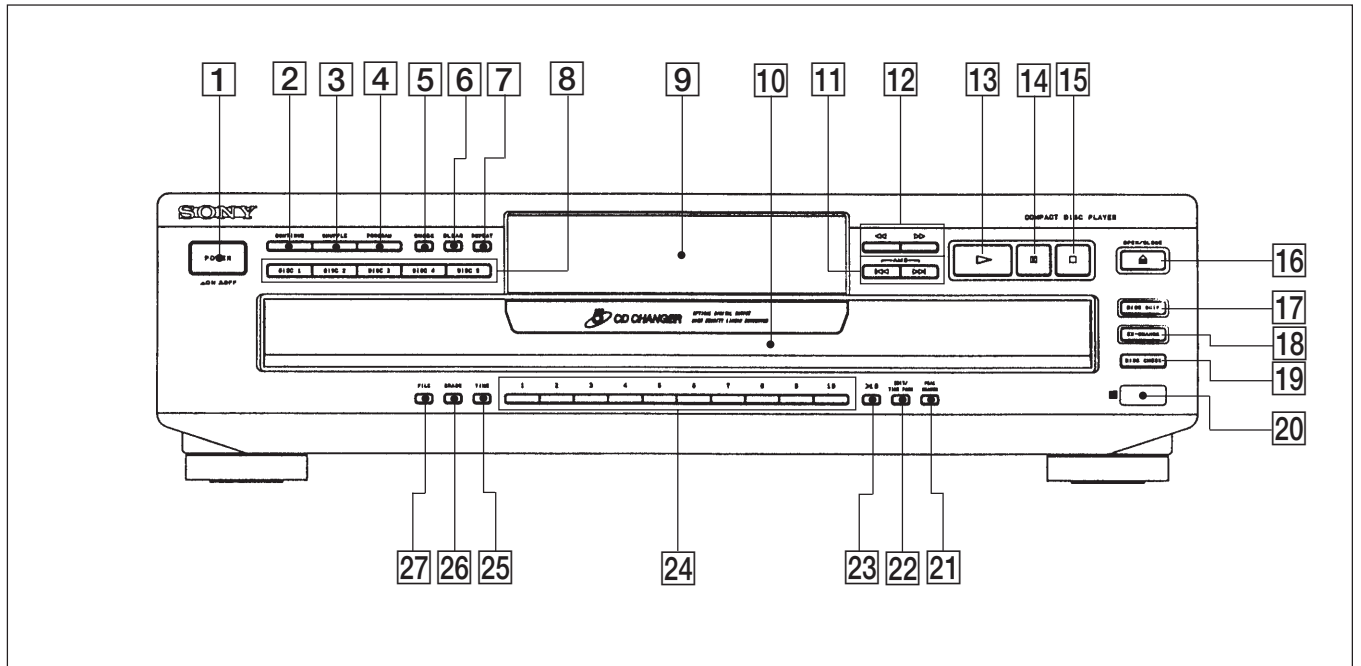

- | | |
|---|--|
| 1 POWER switch | 15 ■ (stop) button |
| 2 CONTINUE button | 16 ▲ OPEN/CLOSE button |
| 3 SHUFFLE button | 17 DISC SKIP button |
| 4 PROGRAM button | 18 EX-CHANGE button |
| 5 CHECK button | 19 DISC CHECK button (CDP-CE305/CE405 only) |
| 6 CLEAR button | 20 Remote sensor |
| 7 REPEAT button | 21 PEAK SEARCH button (CDP-CE305/CE405 only) |
| 8 DISC 1-5 buttons | 22 EDIT/TIME FADE button (CDP-CE305/CE405 only) |
| 9 Display window | 23 >10 (over 10) button |
| 10 Disc tray | 24 Numeric (1-10) buttons |
| 11 ◀◀/▶▶ (AMS*) buttons | 25 TIME button |
| 12 ◀◀/▶▶ (manual search) buttons | 26 FADER button |
| 13 ▶ (play) button | 27 MUSIC SCAN button |
| 14 (pause) button | |

* AMS is the abbreviation for Automatic Music Sensor.

SECTION 2 DISASSEMBLY

Note : Follow the disassembly procedure in the numerical order given.

2-1. CASE, BOTTOM PLATE AND FRONT PANEL

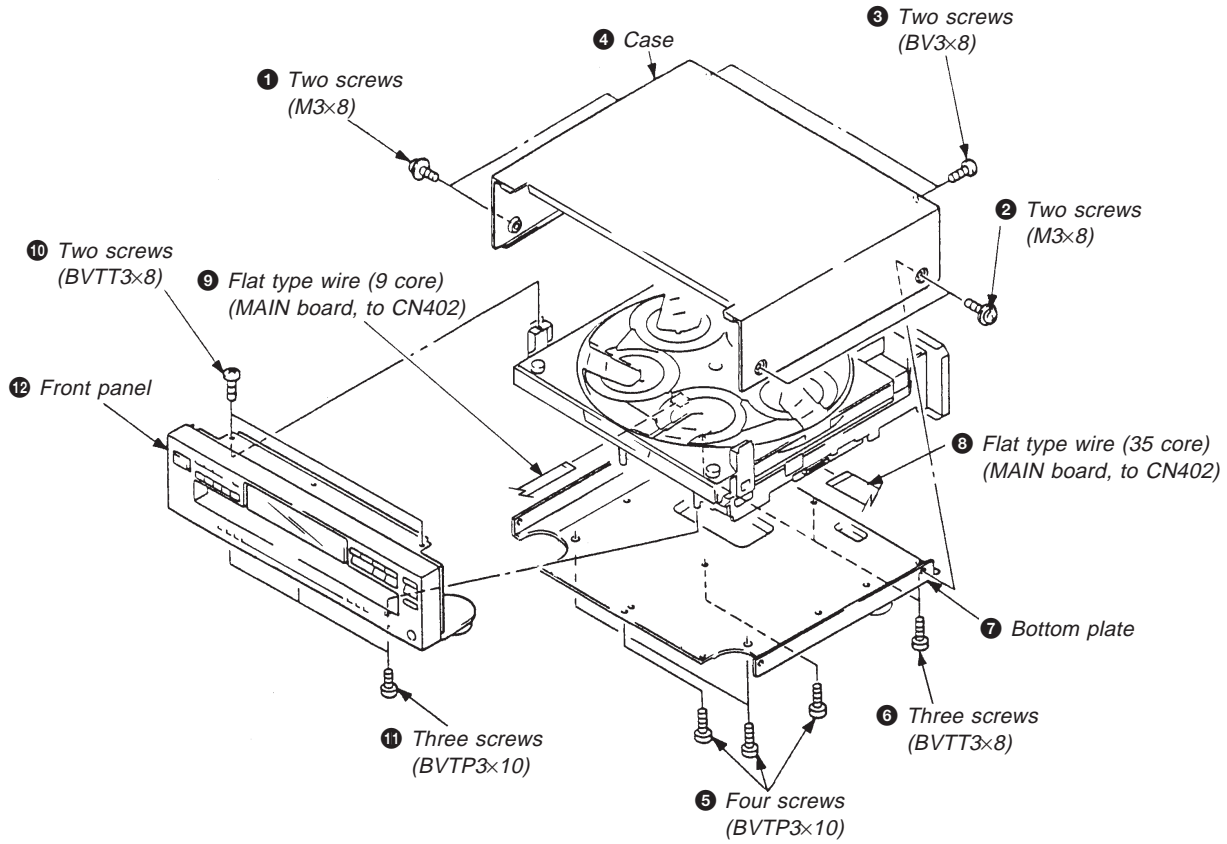

2-2. BACK PANEL AND DISC TABLE

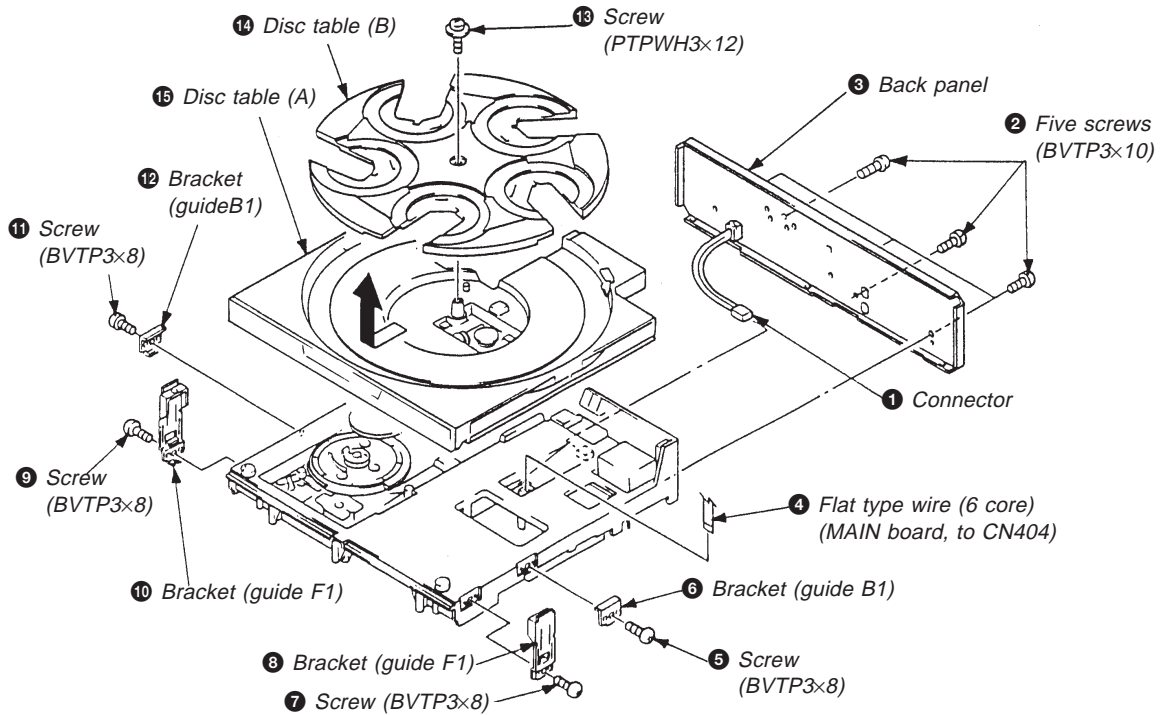

2-3. OPTICAL PICK-UP BLOCK ASSEMBLY

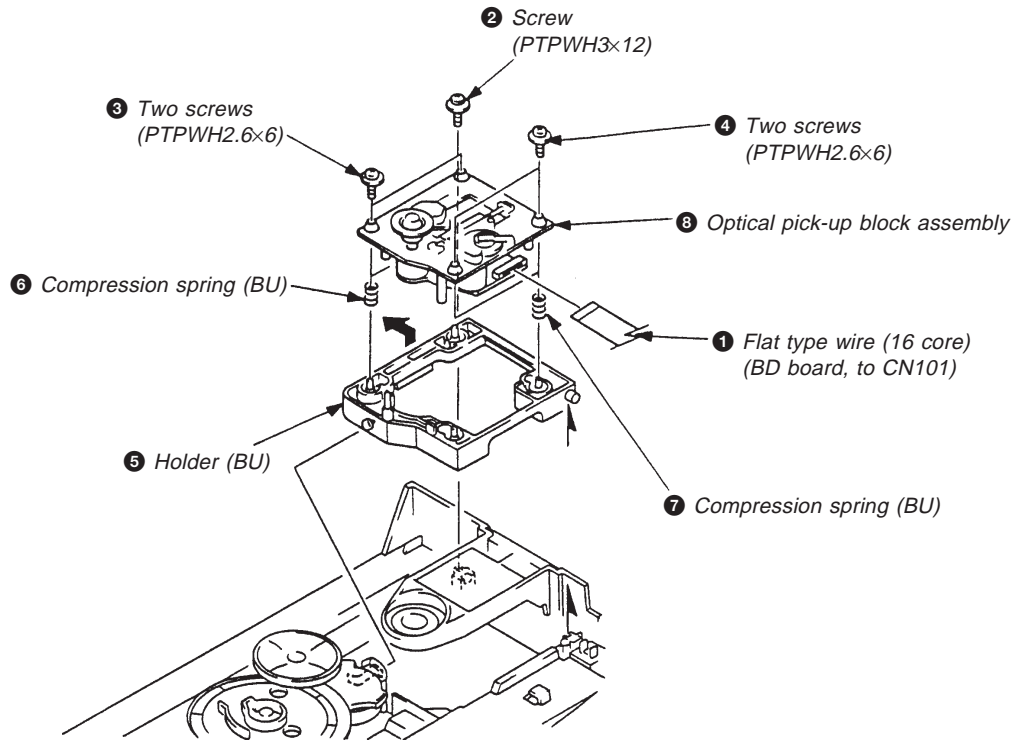

2-4. BRACKET (GEAR) ASSEMBLY

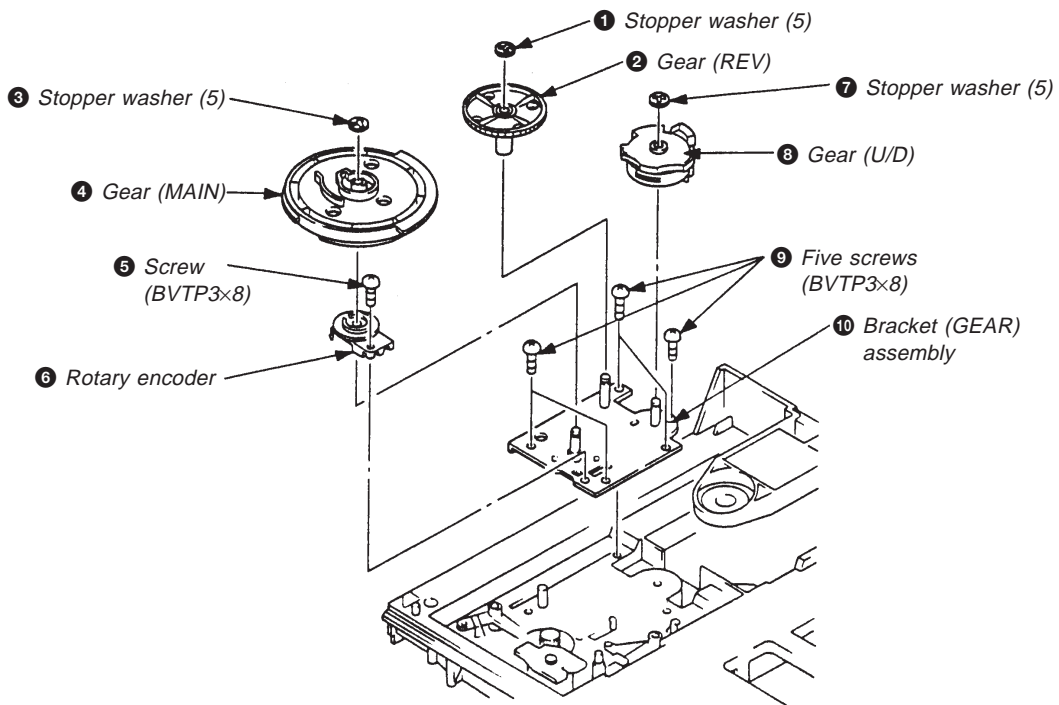

Note : As for the installation of the main gear, refer to "Note for MAIN GAER installation" on page 4.

SECTION 3

ELECTRICAL BLOCK CHECKING

Note :

1. CD Block is basically designed to operate without adjustment. Therefore, check each item in order given.
2. Use YEDS-18 disc (3-702-101-01) unless otherwise indicated.
3. Use an oscilloscope with more than 10M impedance.
4. Clean the object lens using an applicator with neutral detergent when the signal level is low than specified value with the following checks.

S Curve Check

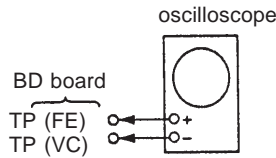

Procedure :

1. Connect oscilloscope to test point TP (FE) on BD board.
2. Connect between test point TP (FEI) and TP (VC) by lead wire.
3. Turn Power switch on.
4. Put disc (YEDS-18) in and turn Power switch on again and actuate the focus search. (actuate the focus search when disc table is moving in and out.)
5. Check if the oscilloscope waveform (S-curve) is symmetrical between A and B. And confirm peak to peak level within 3 ± 1 Vp-p.

S-curve waveform

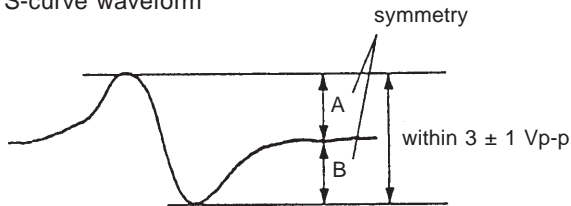

6. After check, remove the lead wire connected in step 2.

Note :

- Try to measure several times to make sure than the ratio of A : B or B : A is more than 10 : 7.
- Take sweep time as long as possible and light up the brightness to obtain best waveform.

RF Level Check

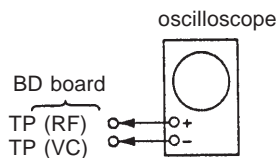

Procedure :

1. Connect oscilloscope to test point TP (RF) on BD board.
2. Turned Power switch on.
3. Put disc (YEDS-18) in to play the number five track.
4. Confirm that oscilloscope waveform is clear and check if RF signal level is correct or not.

Note :

A clear RF signal waveform means that the shape “ \diamond ” can be clearly distinguished at the center of the waveform.

RF signal waveform

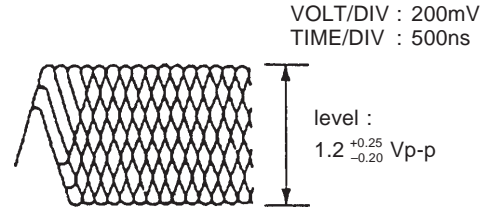

E-F Balance Check

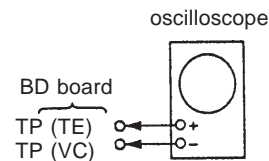

Procedure :

1. Connect test point TP (ADJ) to ground with a lead wire.
2. Connect oscilloscope to test point TP (TE) on BD board.
3. Turned Power switch on.
4. Put disc (YEDS-18) in to play the number five track.
5. Press the “3” button. (The tracking servo and the sledding servo are turned OFF.)
6. Check the level B of the oscilloscope's waveform and the A (DC voltage) of the center of the Traverse waveform. Confirm the following :
 $A/B \times 100 = \text{less than } \pm 22\%$

Traverse waveform

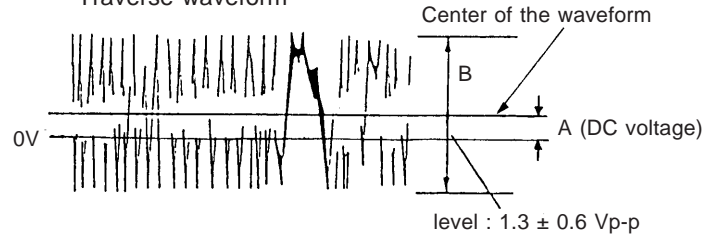

7. Press the “8” button. (The tracking servo and sledding servo are turned ON.) Confirm the C (DC voltage) is almost equal to the A (DC voltage) is step 6.

Traverse waveform

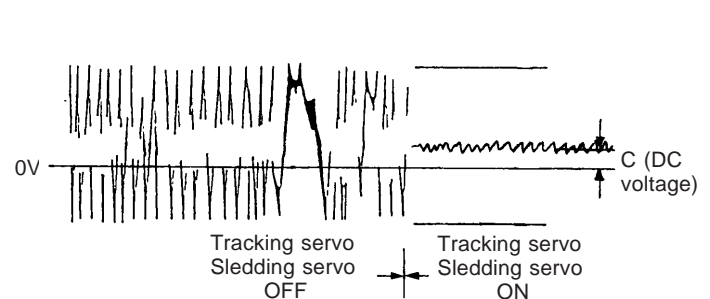

8. Disconnect the lead wire of TP (ADJ) connected in step 1.

RF PLL Free-run Frequency Check

Procedure :

1. Connect frequency counter to test point (PLCK) with lead wire.

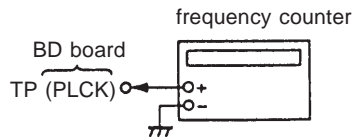

2. Turned Power switch on.
3. Put the disc (YEDS-18) in to play the number five track.
Confirm that reading on frequency counter is 4.3218MHz.

Adjustment Location :

[BD BOARD] — Conductor Side —

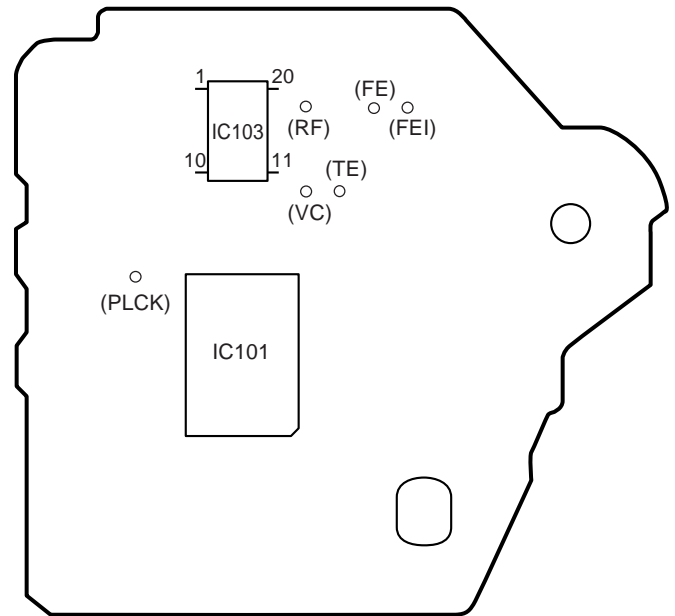

[MAIN BOARD] — Conductor Side —

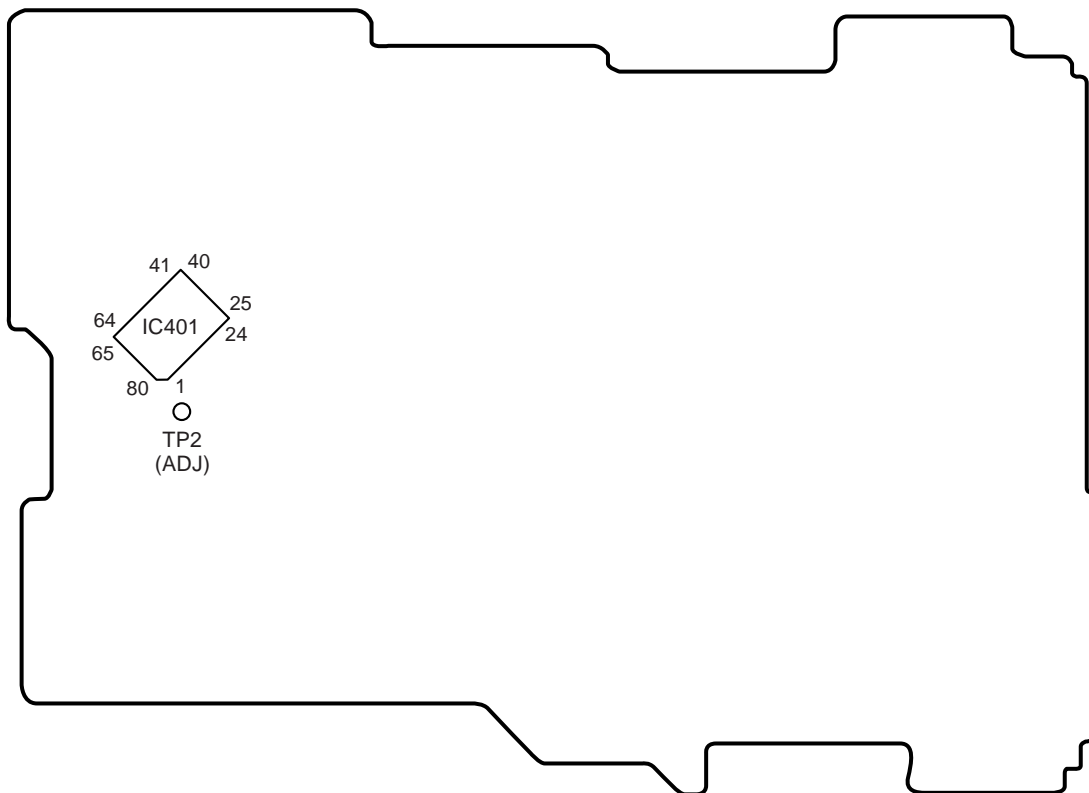

SECTION 4
DIAGRAMS

4-1. CIRCUIT BOARDS LOCATION

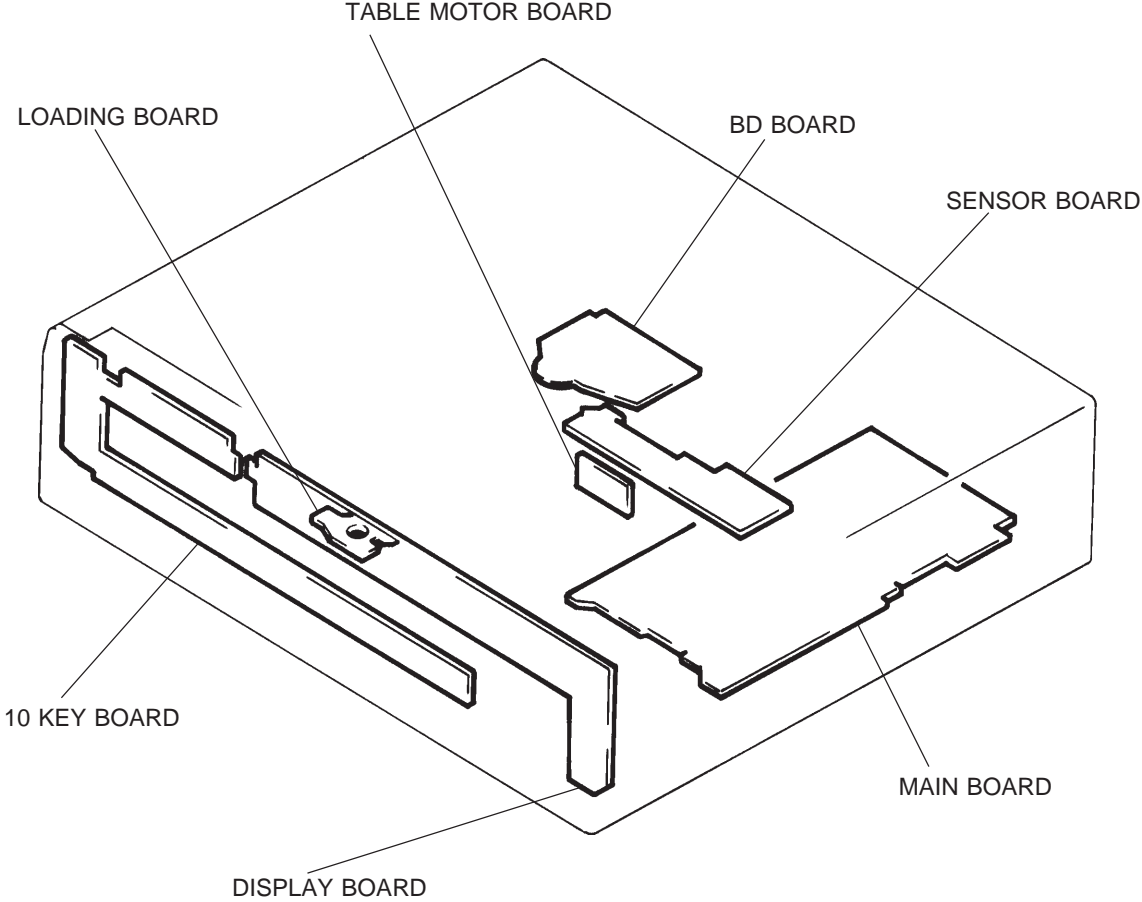

4-2. PRINTED WIRING BOARD — BD SECTION —

• See page 10 for Circuit Board Location.

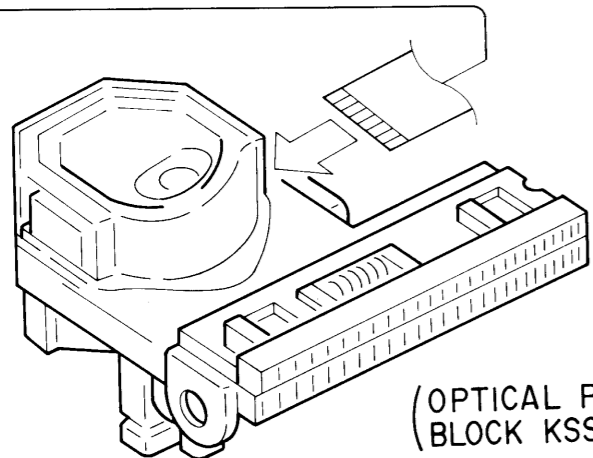
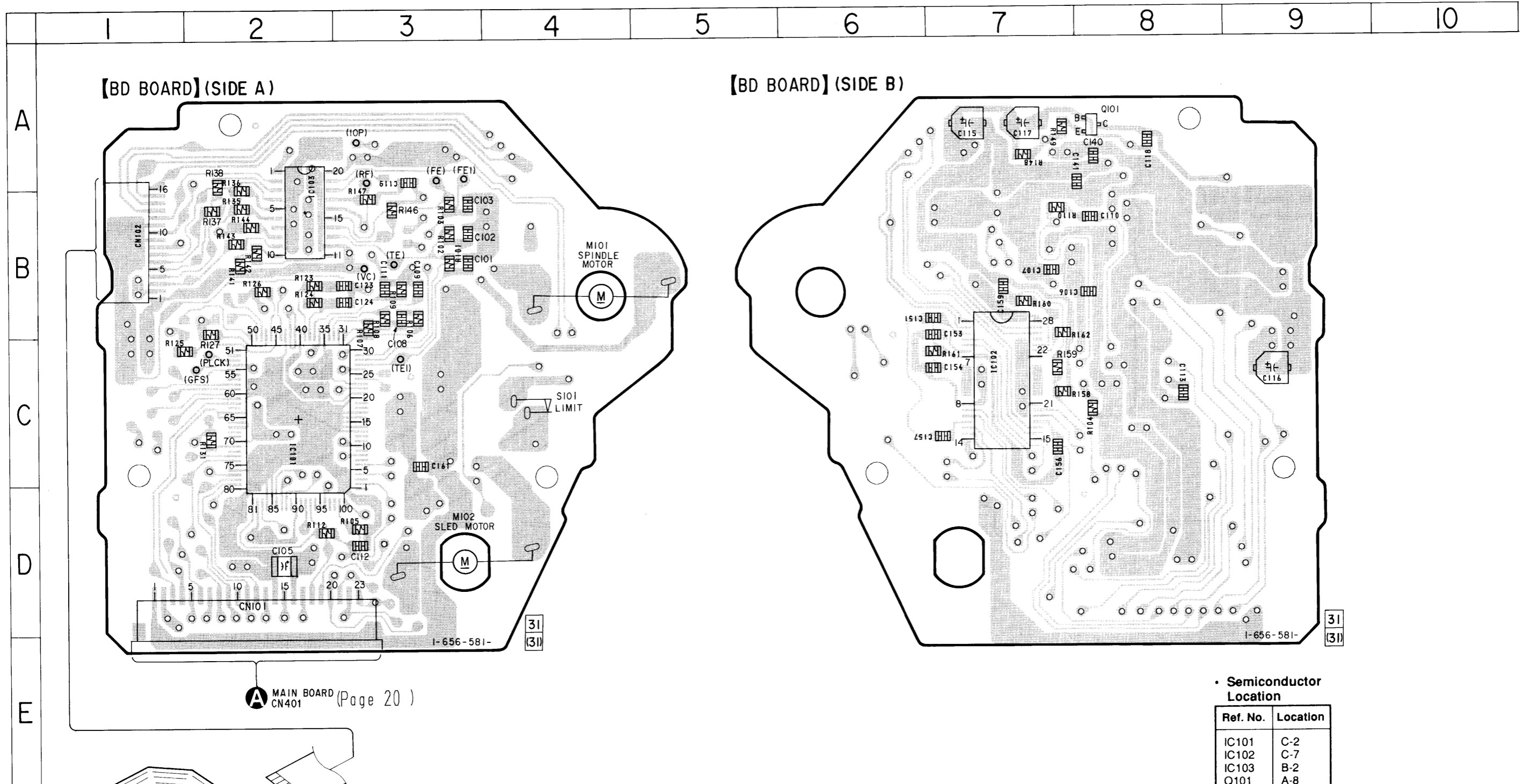

Note:

- : parts extracted from the component side.
- : parts extracted from the component side.
- : Through hole.
- ▨ : Pattern from the side which enable seeing.
(The other layer's patterns are not indicated.)

4-3. SCHEMATIC DIAGRAM — BD SECTION —
• See page 24 for IC Pin Functions. (IC101)

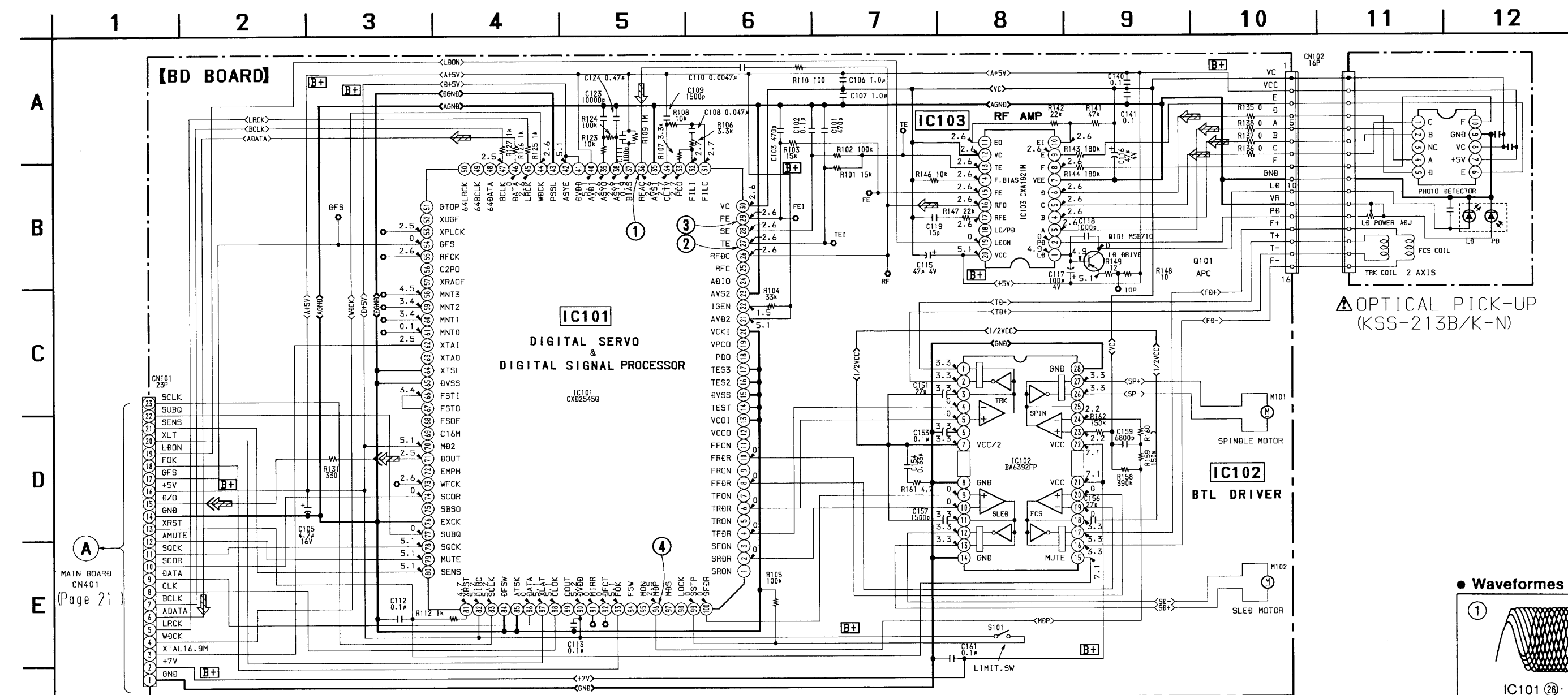

NOTE

- All capacitors are in μF unless otherwise noted, $\text{pF}:\mu\text{F}$ 50W or less are not indicated except for electrolytics and tantalums.
- All resistors are in Ω and $1/4\text{W}$ or less unless otherwise specified.

Note:
The components identified by mark Δ or dotted line with mark Δ are critical for safety. Replace only with part number specified.

Note:
Les composants identifiés par une marque Δ sont critiques pour la sécurité. Ne les remplacer que par une pièce portant le numéro spécifié.

- B+ : B+ Line.
- ⚠ : Signal path.
- \Rightarrow : DC
- \Rightarrow : digital out
- Voltages and waveforms are dc with respect to ground under no-signal conditions. no mark: STOP
- Voltages are taken with a VOM (input impedance $10\text{M}\Omega$). Voltage variations may be noted due to normal production tolerances.
- Waveforms are taken with an oscilloscope. Voltage variations may be noted due to normal production tolerances.
- Circled numbers refer to waveforms.

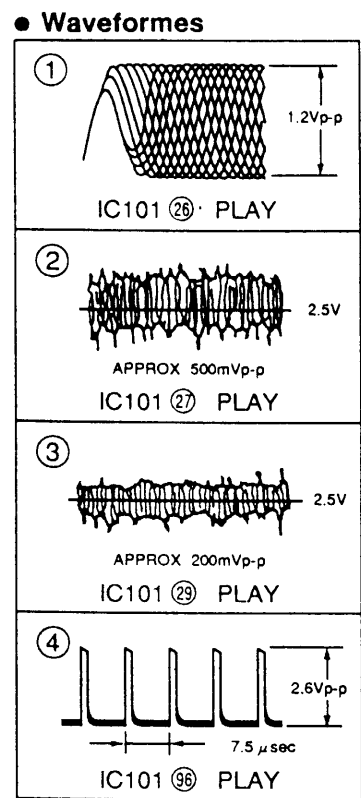

4-4. IC BLOCK DIAGRAMS

IC101 CXA2545Q

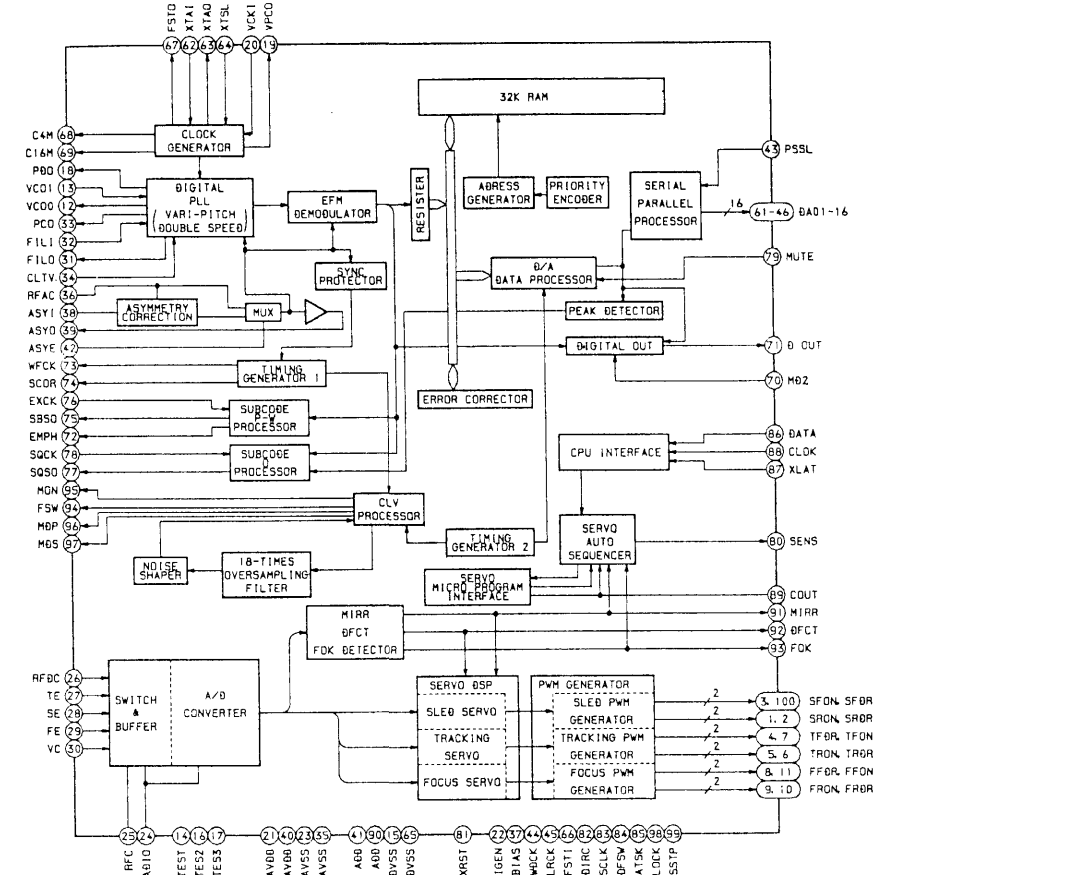

IC102 BA6392FP

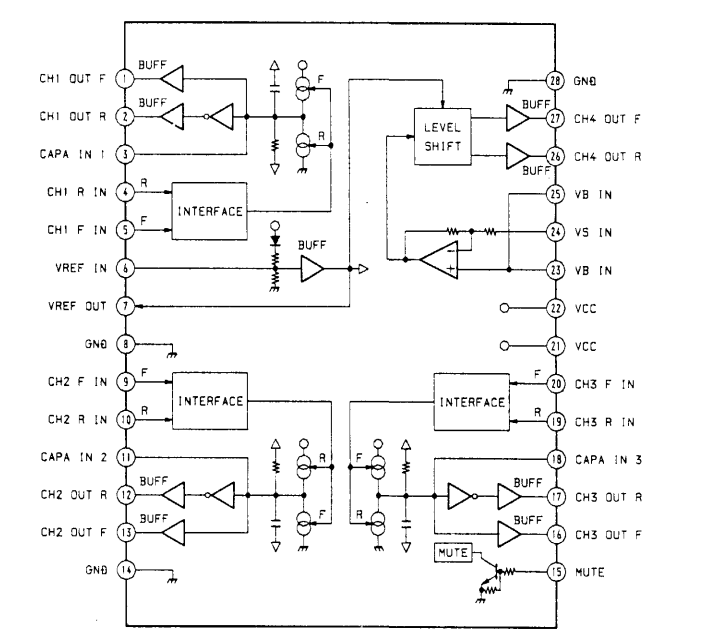

IC103 CXA1821M

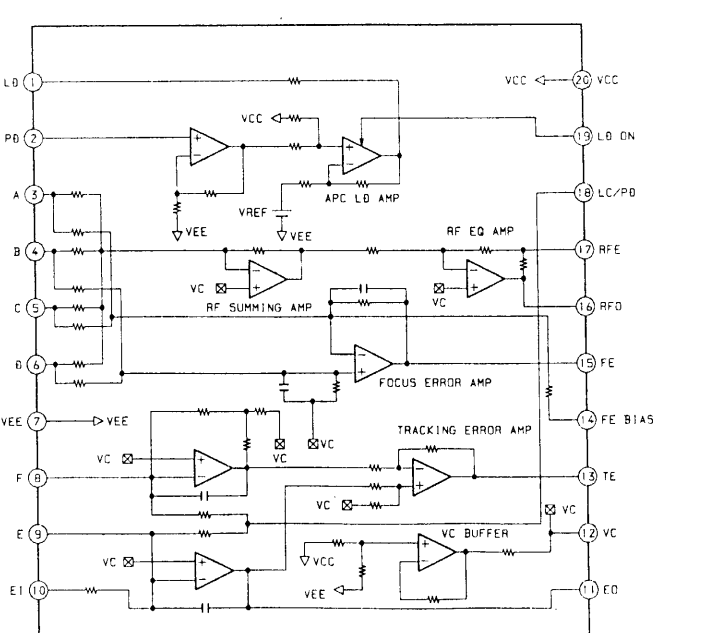

IC301 CXD8567AM

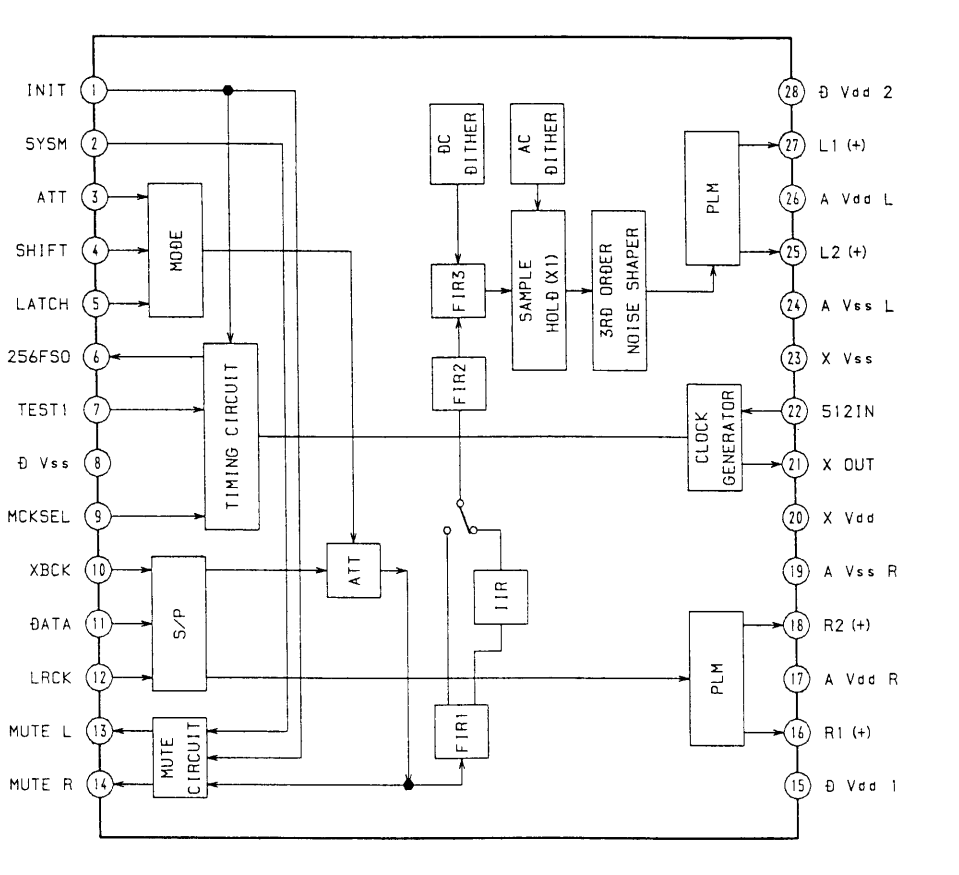

IC601 LA5602

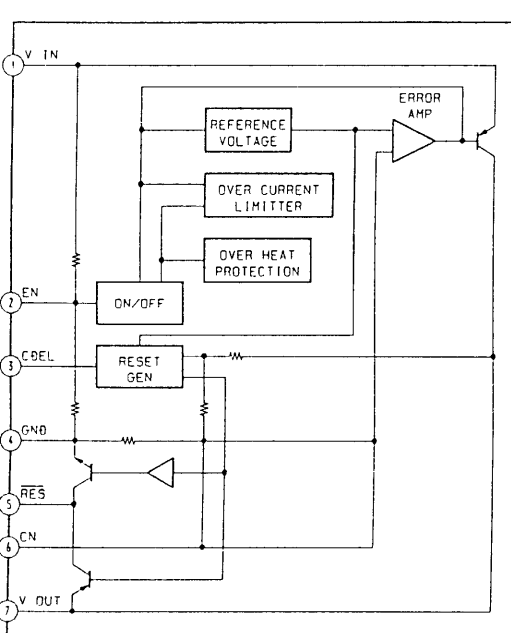

IC304 CXA1291P

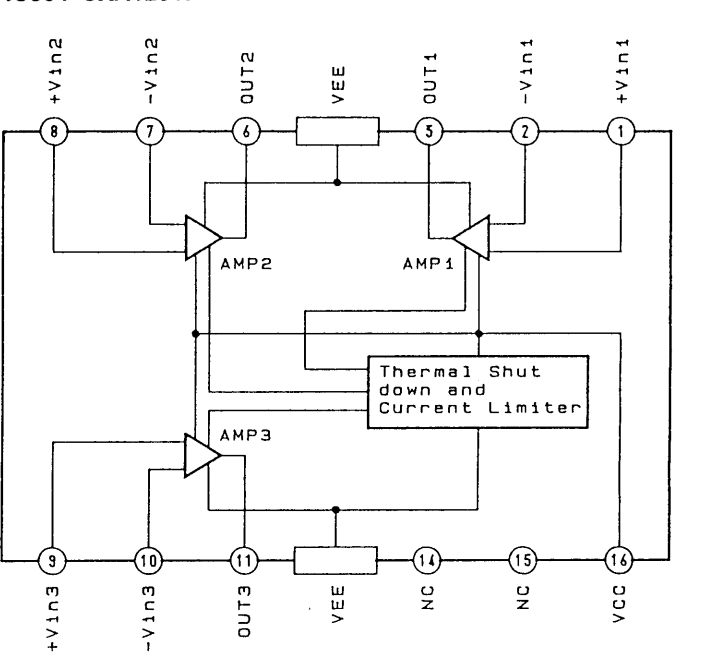

IC603 M5293L

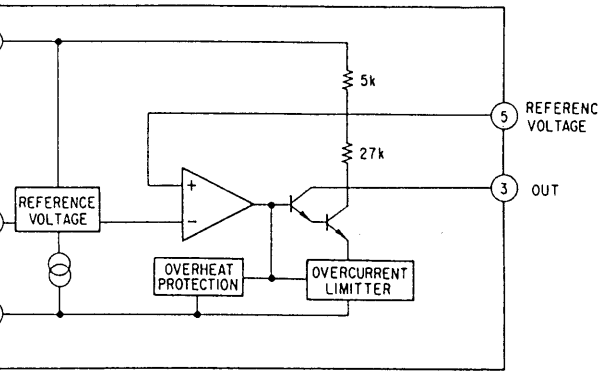

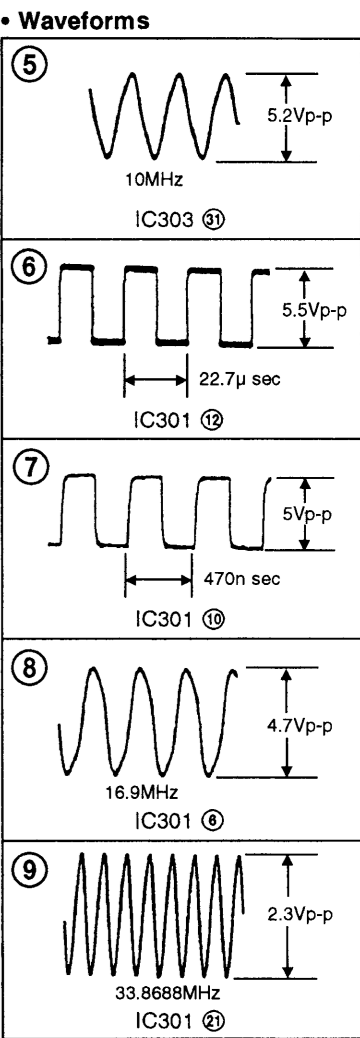
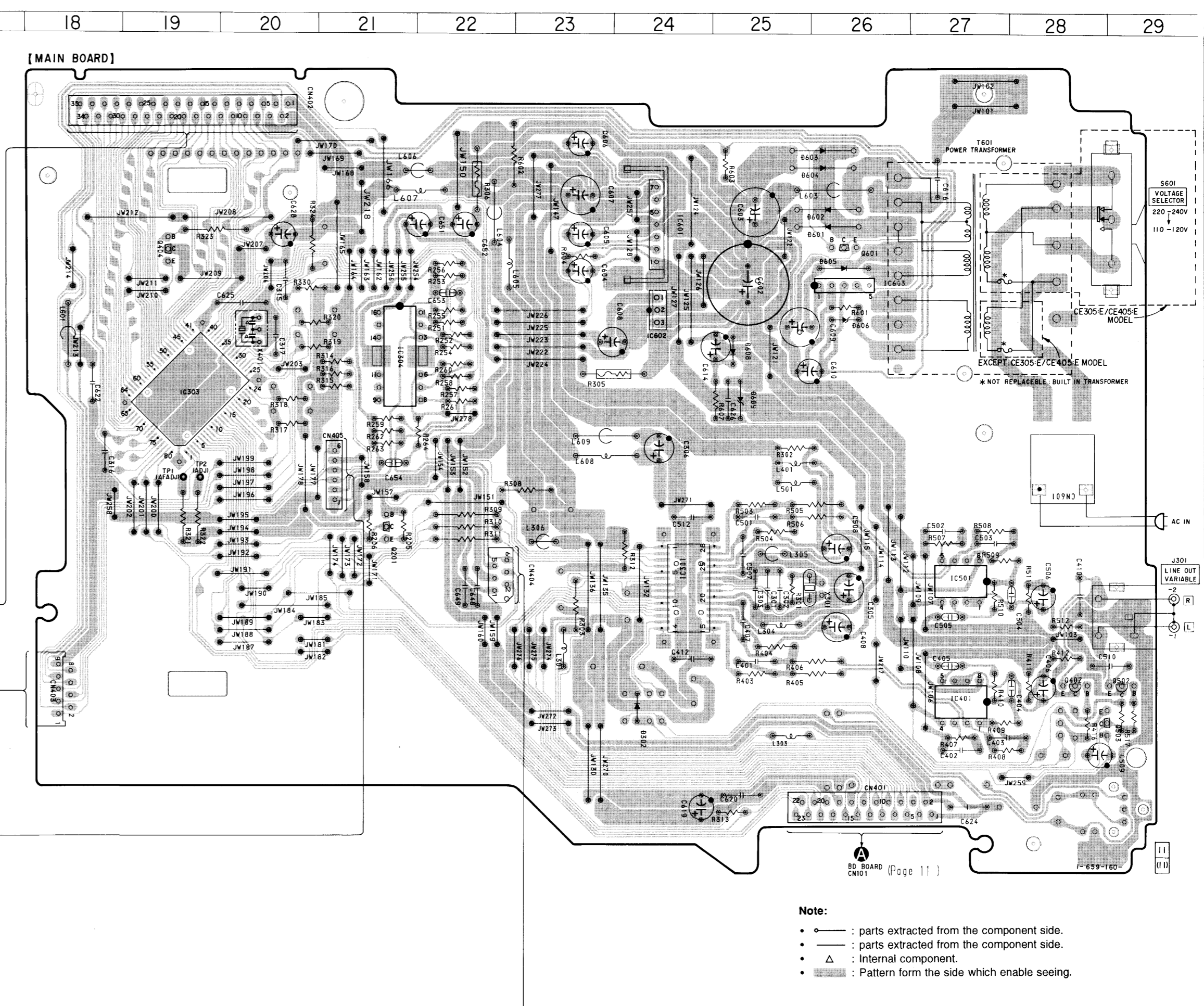
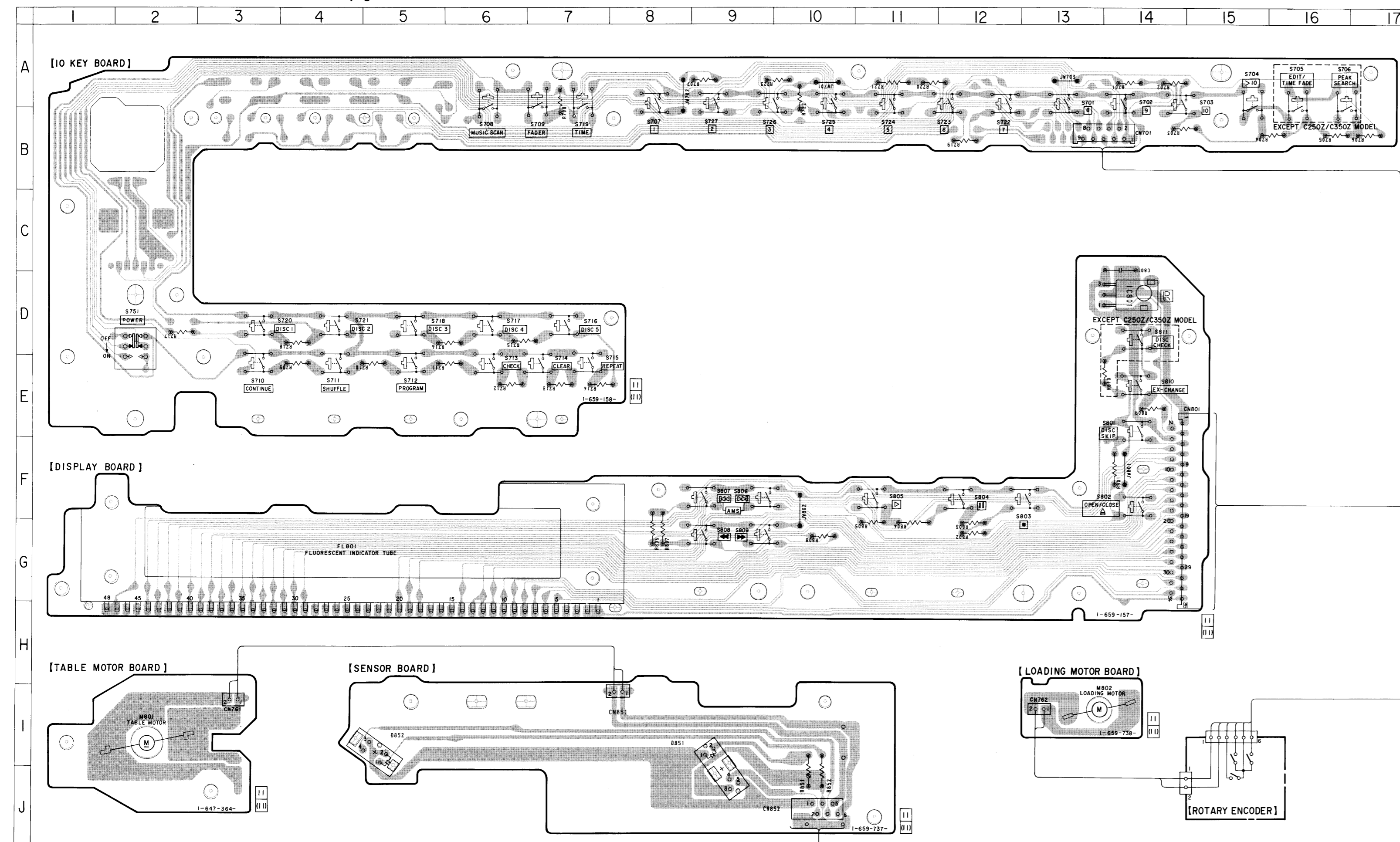

• Semiconductor Location

Ref. No.	Location
D302	H-24
D601	C-26
D602	B-26
D603	B-25
D604	B-25
D605	C-26
D606	C-26
D608	D-25
D609	D-25
D851	I-8
D852	I-5
IC301	F-24
IC303	D-19
IC304	D-21
IC401	G-27
IC501	F-27
IC601	C-24
IC602	D-24
IC603	C-26
IC801	C-14
Q201	F-21
Q402	G-28
Q404	C-19
Q502	G-29
Q503	H-29
Q601	C-26

Note:

- : parts extracted from the component side.
- : parts extracted from the component side.
- △ : Internal component.
- ▨ : Pattern form the side which enable seeing.

4-6. SCHEMATIC DIAGRAM — MAIN SECTION —

- See page 16 for IC Block Diagrams.
- See page 27 for IC Pin Functions. (IC303)

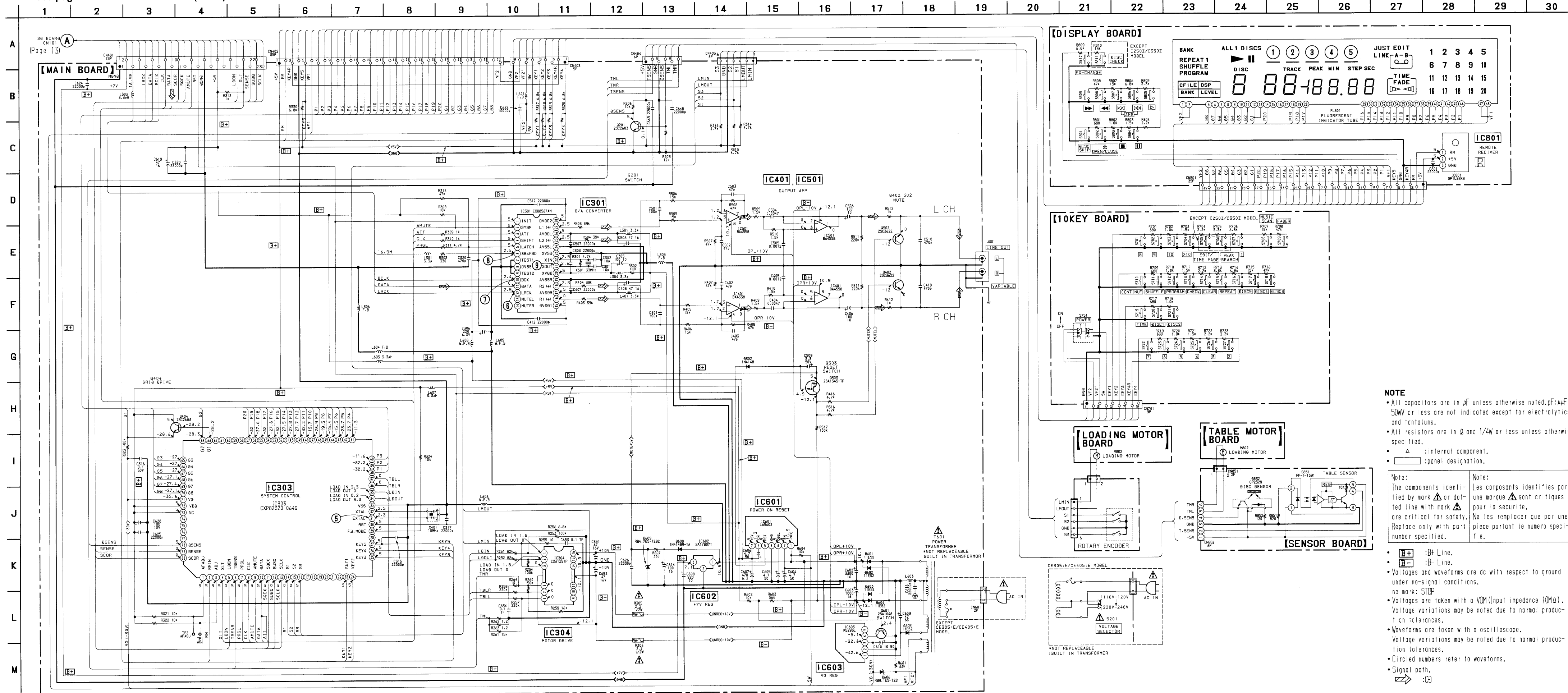

NOTE

- All capacitors are in μF unless otherwise noted. pF: pF
- 50W or less are not indicated except for electrolytics and tantalums.
- All resistors are in Ω and 1/4W or less unless otherwise specified.
- Δ : internal component.
- \square : panel designation.

Note:

The components identified by mark Δ or dotted line with mark Δ are critical for safety. Replace only with part number specified.

Les composants identifiés par une marque Δ sont critiques pour la sécurité. Ne les remplacer que par une pièce portant le numéro spécifié.

- \square : +B Line.
- \square : -B Line.
- Voltages and waveforms are dc with respect to ground under no-signal conditions.
- Voltages are taken with a VOM (input impedance 10M Ω). Voltage variations may be noted due to normal production tolerances.
- Waveforms are taken with an oscilloscope. Voltage variations may be noted due to normal production tolerances.
- Circled numbers refer to waveforms.
- Signal path.
- \Rightarrow : CB

4-7. IC PIN FUNCTIONS

• IC101 DIGITAL SIGNAL PROCESSOR (CXD2545Q)

Pin No.	Pin Name	I/O	Function
1	SRON	O	Sled drive output (Not used)
2	SRDR	O	Sled drive output
3	SFON	O	Sled drive output (Not used)
4	TFDR	O	Tracking drive output
5	TRON	O	Tracking drive output (Not used)
6	TRDR	O	Tracking drive output
7	TFON	O	Tracking drive output (Not used)
8	FFDR	O	Focus drive output
9	FRON	O	Focus drive output (Not used)
10	FRDR	O	Focus drive output
11	FFON	O	Focus drive output (Not used)
12	VCOO	O	VCO output for analog EFM PLL (Not used)
13	VCOI	I	VCO output for analog EFM PLL (GND)
14	TEST	I	TEST pin connected normally to GND
15	DVss	–	Digital GND
16	TES2	I	TEST pin connected normally to GND
17	TES3	I	TEST pin connected normally to GND
18	PDO	O	Charge-pump output for analog EFM PLL (Not used)
19	VPCO	O	Charge-pump output for variable pitch PLL (Not used)
20	VCKI	I	Clock input from variable pitch external VCO (GND)
21	AVD2	–	Analog power supply
22	IGEN	I	Power supply pin for operational amplifiers
23	AVS2	–	Analog GND
24	ADIO	I	(Not used)
25	RFC	O	(Not used)
26	RFDC	I	RF signal input
27	TE	I	Tracking error signal input
28	SE	I	Sled error signal input
29	FE	I	Focus error signal input
30	VC	I	Center voltage input pin
31	FILO	O	Filter output for master PLL
32	FILI	I	Filter input for master PLL
33	PCO	O	Charge-pump output for master PLL
34	CLTV	I	Control voltage input for master VCO
35	AVS1	–	Analog GND
36	RFAC	I	EFM signal input
37	BIAS	I	Asymmetry circuit constant current input
38	ASYI	I	Asymmetry compare voltage input
39	ASYO	O	EFM full swing output
40	AVD1	–	Analog power supply

Pin No.	Pin Name	I/O	Function
41	DVDD	–	Digital power supply
42	ASYE	I	Asymmetry circuit ON/OFF
43	PSSL	I	Audio data output mode selection input
44	WDCK	O	48-bit slot D/A interface. Word clock.
45	LRCK	O	48-bit slot D/A interface. LR clock.
46	DATA	O	DA 16 output when PSSL=1.48-bit slot serial data when PSSL=0
47	BCLK	O	DA 15 output when PSSL=1.48-bit slot data when PSSL=0
48	64DATA	O	DA 14 output when PSSL=1.64-bit slot data when PSSL=0 (Not used)
49	64BCLK	O	DA 13 output when PSSL=1.64-bit slot data when PSSL=0 (Not used)
50	64LRCK	O	DA 12 output when PSSL=1.64-bit slot data when PSSL=0 (Not used)
51	GTOP	O	DA 11 output when PSSL=1.GTOP output when PSSL=0 (Not used)
52	XUGF	O	DA 10 output when PSSL=1.XUGF output when PSSL=0 (Not used)
53	XPLCK	O	DA 09 output when PSSL=1.XPLCK output when PSSL=0
54	GFS	O	DA 08 output when PSSL=1.GFS output when PSSL=0
55	PFCK	O	DA 07 output when PSSL=1.RFCK output when PSSL=0
56	C2PO	O	DA 06 output when PSSL=1.C2PO output when PSSL=0 (Not used)
57	XRA0F	O	DA 05 output when PSSL=1.XRA0F output when PSSL=0
58	MNT3	O	DA 04 output when PSSL=1.MNT3 output when PSSL=0
59	MNT2	O	DA 03 output when PSSL=1.MNT2 output when PSSL=0
60	MNT1	O	DA 02 output when PSSL=1.MNT1 output when PSSL=0
61	MNT0	O	DA 01 output when PSSL=1.MNT0 output when PSSL=0
62	XTAI	I	X'tal oscillator circuit input
63	XTAO	O	X'tal oscillator circuit output (Not used)
64	XTSL	I	X'tal selection input pin (GND)
65	DVss	–	Digital GND
66	FSTI	I	2/3 divider output of pins 62, 63
67	FSTO	O	2/3 divider output of pins 62, 63
68	FSOF	O	(Not used)
69	C16M	O	16.9344 MHz output (Not used)
70	MD2	I	Digital-out ON/OFF control pin (+5V)
71	DOUT	O	Digital-out output pin
72	EMPH	O	Playback disc output in emphasis mode (Not used)
73	WFCK	O	WFCK output
74	SCOR	O	Sub-code sync output
75	SBSO	O	Sub-P through Sub-W serial output (Not used)
76	EXCK	I	Clock input for SBS0 read-out (GND)
77	SUBQ	O	Sub-Q 80-bit output
78	SQCK	I	Muting selection pin
79	MUTE	I	SENS output
80	SENS	O	System reset

Pin No.	Pin Name	I/O	Function
81	XRST	I	System reset
82	DIRC	I	Used in 1-track jump mode (+5v)
83	SCLK	I	SENS serial data read-out clock
84	DFSW	I	DFCT selection pin (GND)
85	ATSK	I	Input pin for anti-shock (GND)
86	DATA	I	Serial data input, supplied from CPU
87	XLAT	I	Latch input, supplied from CPU
88	CLOK	I	Serial data transfer clock input, supplied from CPU
89	COUT	O	Numbers of track counted signal output (Not used)
90	DVDD	–	Digital power supply
91	MIRR	O	Mirror signal output
92	DFCT	O	Defect signal output
93	FOK	O	Focus OK output
94	FSW	O	Output to select spindle motor output filter (Not used)
95	MON	O	Output to control ON/OFF of spindle motor (Not used)
96	NDP	O	Output to control spindle motor servo
97	MDS	O	Output to control spindle motor servo (Not used)
98	LOCK	O	GFS is sampled by 460 Hz. H when GFS is H (Not used)
99	SSTP	I	Input signal to detect disc inner most track
100	SFDR	O	Sled drive output

• IC303 SYSTEM CONTROL (CXP82320-064Q)

Pin No.	Pin Name	I/O	Function
1	AF ADJ	I	Test mode pin. Normally: "H"
2	RM IN	I	Remote control signal input pin.
3	ADJ	I	Test mode pin. Normally: "H"
4	XLT	O	Serial data latch signal output pin.
5	LDON	O	Optical pick-up laser diode control pin. ON: "H"
6	TSENS	I	Slit sensor of disc table input pin.
7	PRGL	O	Latch signal output pin to digital filter IC.
8	CLK	O	Serial clock output pin.
9	AMUTE	O	Analog muting control signal output pin.
10	DATA	O	Serial data output pin.
11	SQCK	O	Subcode Q data readout clock output pin.
12	SUBQ	I	Subcode Q data input pin.
13	SCLK	O	Internal register of SSP/DSP readout clock output pin.
14 to 16	S1 to S3	I	Loading encoder input pin.
17 to 22	–	–	Not used.
23 to 27	KEY1 to KEY5	I	Key input pin. (A/D)
28	–	–	Not used.
29	FB. MODE	I	Disc table feeling and stop precision fine adjustment pin.
30	RST	I	Reset signal input pin.
31	EXTAL	I	10MHz clock input pin.
32	XTAL	O	10MHz clock output pin.
33	V _{SS}	–	GND
34	LODOUT	O	Loading motor control pin.
35	LODIN	O	Loading motor control pin.
36	TBLR	O	Table motor control pin.
37	TBLL	O	Table motor control pin.
38 to 57	P1 to P20	O	FL segment output pin.
58 to 62	–	–	Not used.
63 to 70	G1 to G8	O	FL timing output pin.
71	VG	–	–30V
72	V _{DD}	–	+5V
73	–	–	+5V
74 to 77	–	–	Not used.
78	D.SENS	I	Disc sensor input pin. "L": disc preset.
79	SENSE	I	SENSE signal input pin.
80	SCOR	I	Subcode Q data readout timing signal input pin.

SECTION 5 EXPLODED VIEWS

NOTE:

- Items marked "*" are not stocked since they are seldom required for routine service. Some delay should be anticipated when ordering these items.
- The mechanical parts with no reference number in the exploded views are not supplied.
- Hardware (# mark) list and accessories and packing materials are given in the last of this parts list.

• Abbreviation

- CND :Canadian model
- G :German model
- EE :East European model
- AUS :Australina model
- CH :Chinese model

The components identified by mark \triangle or dotted line with mark \triangle are critical for safety. Replace only with part number specified.

Les composants identifiés par une marque \triangle sont critiques pour la sécurité. Ne les remplacer que par une pièce portant le numéro spécifié.

5-1. FRONT PANEL AND CASE SECTION

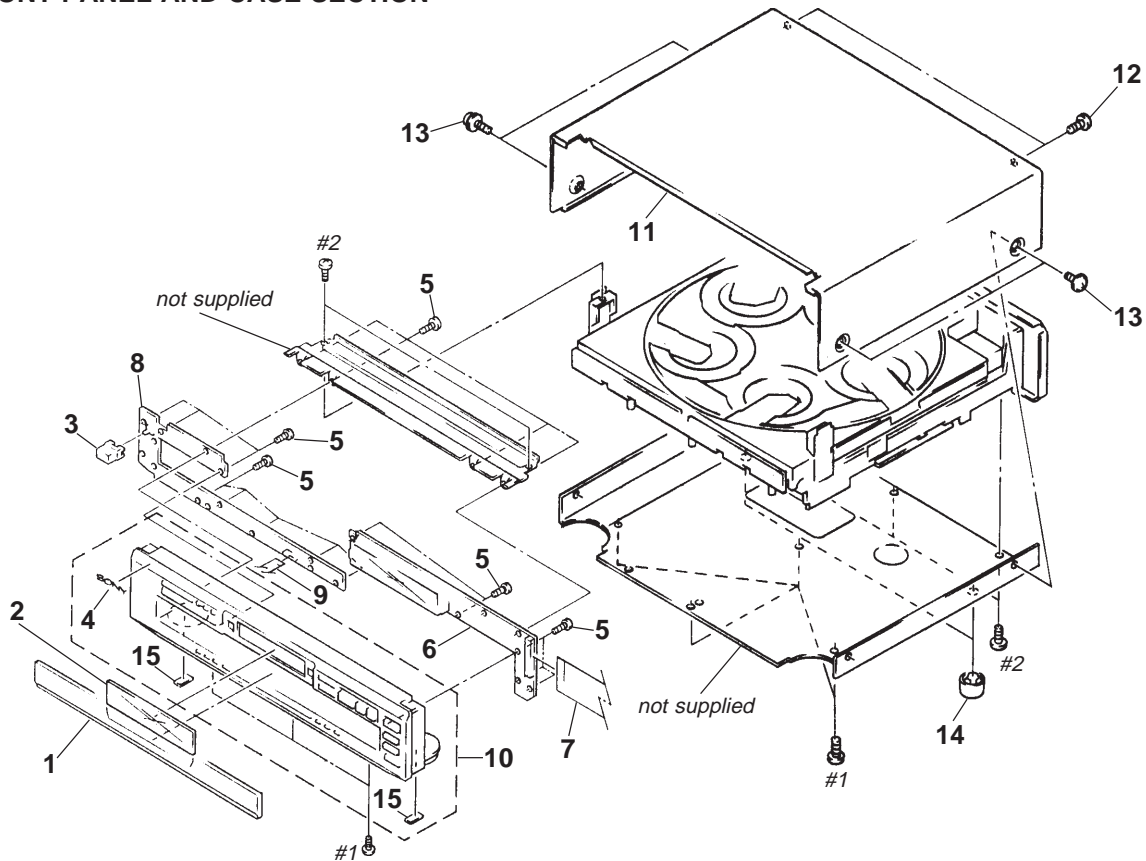

REF.No.	Part No.	Description	Remark	REF.No.	Part No.	Description	Remark
1	4-978-488-01	PANEL, LOADING		10	X-4946-568-1	PANEL ASSY, FRONT (CE305: AEP, E, AUS, CH, G)	
2	4-978-487-01	PLATE (FL), INDICATION		10	X-4946-569-1	PANEL ASSY, FRONT (CE405: US, CND)	
3	4-977-589-01	KNOB, POWER		10	X-4946-570-1	PANEL ASSY, FRONT	
4	4-963-404-21	EMBLEM (5-A), SONY				(CE405: AEP, UK, E, AUS, CH, G, EE)	
5	4-951-620-01	SCREW (2.6 x 8), +BVTP		10	X-4946-961-1	PANEL ASSY, FRONT (C250Z)	
* 6	A-4673-782-A	DISPLAY BOARD, COMPLETE (CE305/CE405)		10	X-4946-962-1	PANEL ASSY, FRONT (C350Z)	
* 6	A-4673-954-A	DISPLAY BOARD, COMPLETE (C250Z/C350Z)		* 11	4-978-492-11	CASE	
7	1-776-125-11	WIRE (FLAT TYPE) (35 CORE)		12	3-703-685-21	SCREW (+BV 3 x 8)	
* 8	A-4673-781-A	10 KEY BOARD, COMPLETE (CE305/CE405)		13	3-704-366-01	SCREW (CASE) (M3 x 8)	
* 8	A-4673-953-A	10 KEY BOARD, COMPLETE (C250Z/C350Z)		14	4-933-601-01	FOOT	
9	1-776-124-11	WIRE (FLAT TYPE) (9 CORE)		15	4-978-398-01	CUSHION	
10	X-4946-567-1	PANEL ASSY, FRONT (CE305: US, CND)					

5-2. BACK PANEL AND DISC TABLE SECTION

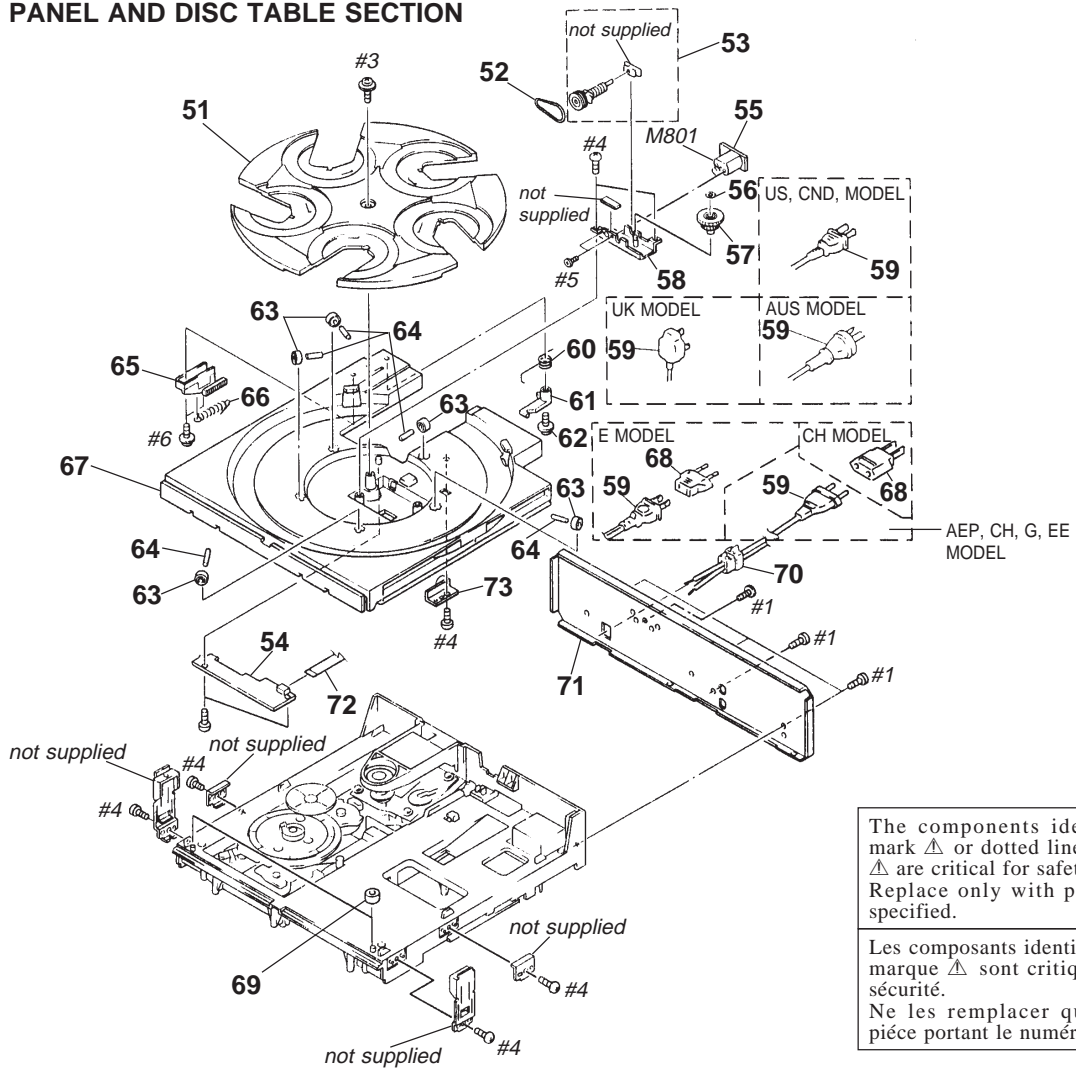

The components identified by mark \triangle or dotted line with mark \triangle are critical for safety. Replace only with part number specified.

Les composants identifiés par une marque \triangle sont critiques pour la sécurité. Ne les remplacer que par une pièce portant le numéro spécifié.

REF.No.	Part No.	Description	Remark	REF.No.	Part No.	Description	Remark
	51	4-957-299-11	TABLE (B), DISC		\triangle 68	1-569-008-11	ADAPTER, CONVERSION 2P (CH)
	52	4-957-304-01	BELT (RM)		* 69	4-951-619-01	CUSHION (A)
	53	X-4943-479-1	GEAR (ROTARY A) ASSY		* 70	3-703-244-00	BUSHING (2104), CORD (EXCEPT E)
	* 54	1-659-737-11	SENSOR BOARD		* 70	3-703-571-11	BUSHING (S) (4516), CORD (E)
	* 55	1-647-364-11	TABLE MOTOR BOARD		* 71	4-978-490-01	PANEL, BACK (CE305: US)
	56	3-325-697-01	WASHER		* 71	4-978-490-11	PANEL, BACK (CE305: CND)
	57	4-957-284-01	GEAR (ROTARY B)		* 71	4-978-490-31	PANEL, BACK (CE305: G)
	58	X-4943-477-1	BRACKET (RM) ASSY		* 71	4-978-490-41	PANEL, BACK (CE305: AUS)
	\triangle 59	1-558-943-61	CORD, POWER (E)		* 71	4-978-490-51	PANEL, BACK (CE305: E)
	\triangle 59	1-575-651-21	CORD, POWER (AEP, CH, G, EE)		* 71	4-978-490-61	PANEL, BACK (CE305: CH)
	\triangle 59	1-590-926-11	CORD, POWER (US, CND)		* 71	4-978-490-71	PANEL, BACK (C250Z)
	\triangle 59	1-696-845-11	CORD, POWER (AUS)		* 71	4-978-490-81	PANEL, BACK (C350Z)
	\triangle 59	1-751-529-11	CORD, POWER (UK)		* 71	4-978-767-01	PANEL, BACK (CE405: US)
	60	4-957-293-01	SPRING (RACK RELEASE)		* 71	4-978-767-11	PANEL, BACK (CE405: CND)
	61	4-957-291-01	LEVER (RACK RELEASE)		* 71	4-978-767-21	PANEL, BACK (AEP/CE405: CH, EE)
	62	4-957-868-01	SCREW (+PTPWH 2.6 x 20)		* 71	4-978-767-31	PANEL, BACK (CE405: G)
	63	X-4924-457-1	ROLLER ASSY		* 71	4-978-767-41	PANEL, BACK (UK)
	64	4-934-376-01	SHAFT (ROLLER)		* 71	4-978-767-51	PANEL, BACK (CE405: AUS)
	65	4-957-292-01	SLIDER (RACK)		* 71	4-978-767-61	PANEL, BACK (CE405: E)
	66	4-957-294-01	SPRING (D.T), TENSION		72	1-751-052-11	WIRE (FLAT TYPE) (6 CORE)
	67	4-957-298-01	TABLE (A), DISC		73	X-4943-480-1	BRACKET (ROLLER D) ASSY
	\triangle 68	1-569-007-11	ADAPTER, CONVERSION 2P (E)		M801	A-4660-525-A	MOTOR ASSY, ROTARY (TABLE)

5-3. CHASSIS SECTION

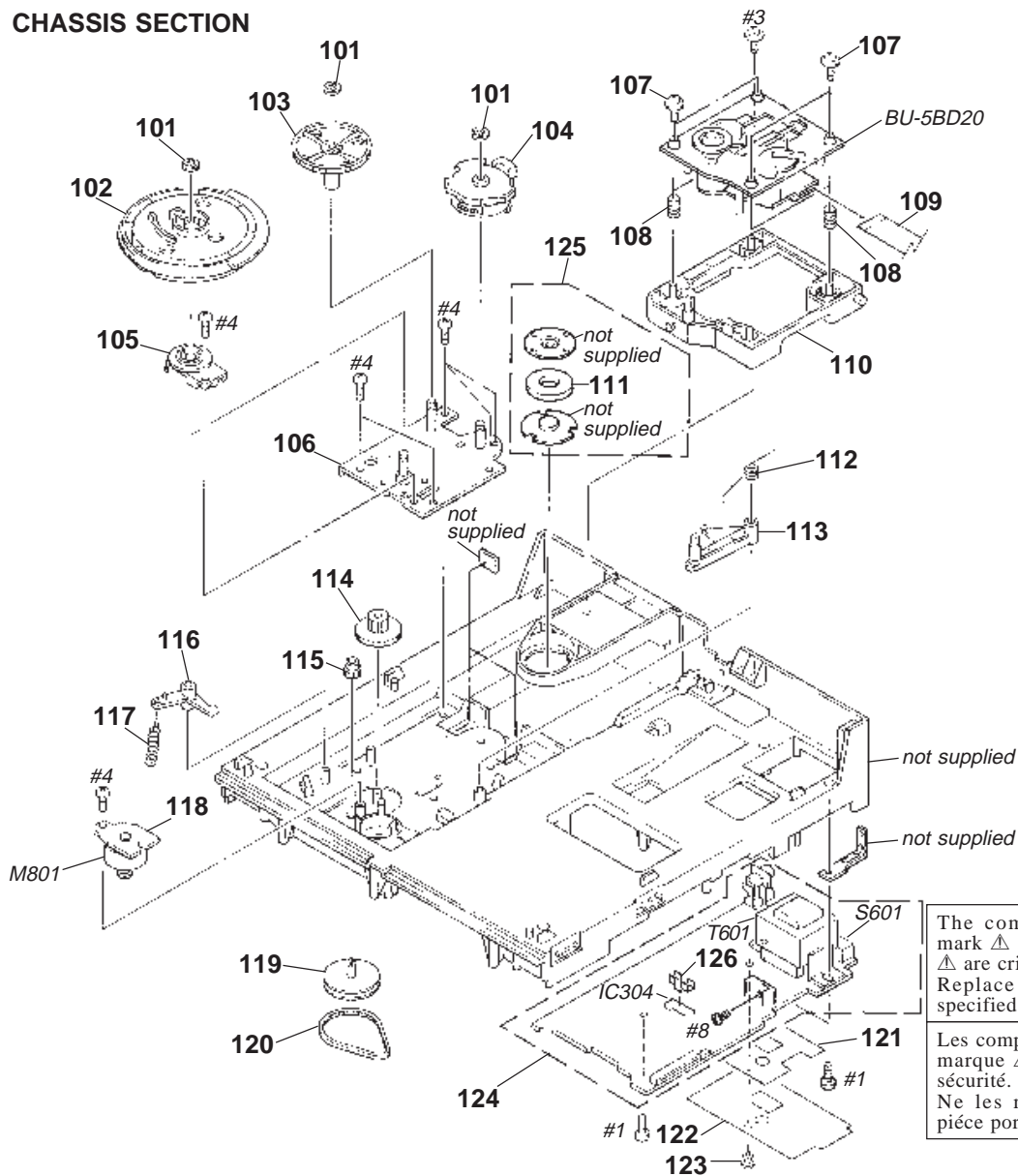

The components identified by mark Δ or dotted line with mark Δ are critical for safety. Replace only with part number specified.

Les composants identifiés par une marque Δ sont critiques pour la sécurité. Ne les remplacer que par une pièce portant le numéro spécifié.

REF.No.	Part No.	Description	Remark	REF.No.	Part No.	Description	Remark
101	4-957-283-01	WASHER (5), STOPPER		* 118	1-659-738-11	LOADING BOARD	
102	4-957-288-01	GEAR (MAIN)		119	X-4941-529-1	PULLEY ASSY	
103	4-957-287-01	GEAR (REV)		120	4-944-490-01	BELT (TIMING)	
104	4-957-286-01	GEAR (U/D)		* 121	4-957-555-01	SHEET, INSULATING (EXCEPT US, CND)	
105	1-466-996-11	ENCODER, ROTARY		* 122	4-957-556-01	SHEET, INSULATING (EXCEPT US, CND)	
106	X-4946-195-1	BRACKET (GEAR) ASSY		123	3-531-576-11	RIVET (EXCEPT US, CND)	
107	4-933-134-01	SCREW (+PTPWH M2.6 x 6)		* 124	A-4673-784-A	MAIN BOARD, COMPLETE (US, CND, CH)	
108	4-948-503-01	SPRING (BU), COMPRESSION		* 124	A-4673-785-A	MAIN BOARD, COMPLETE (EXCEPT US, CND, CH, E)	
109	1-765-443-11	WIRE (FLAT TYPE) (23 CORE)		* 124	A-4673-786-A	MAIN BOARD, COMPLETE (E)	
110	4-957-289-12	HOLDER (BU)		* 125	A-4660-652-A	MAGNET ASSY	
111	1-452-538-41	MAGNET		* 126	4-922-525-01	HEAT SINK	
112	4-957-281-01	SPRING (LOCK LEVER)		Δ S601	1-572-675-11	SWITCH, POWER VOLTAGE CHANGE (VOLTAGE SELECTOR) (E)	
113	4-957-279-01	LEVER, LOCK		Δ T601	1-423-830-11	TRANSFORMER, POWER (US, CND)	
114	4-957-303-01	GEAR (LOADING C)		Δ T601	1-429-394-11	TRANSFORMER, POWER (EXCEPT US, CND, E)	
115	4-934-375-01	GEAR (LOADING B)		Δ T601	1-429-395-11	TRANSFORMER, POWER (E)	
116	4-957-285-01	LEVER, SET		M802	A-4660-914-A	MOTOR ASSY, LOADING (LOADING)	
117	4-962-087-01	SPRING (S), TENSION					

5-4. BASE UNIT SECTION (BU-5BD20)

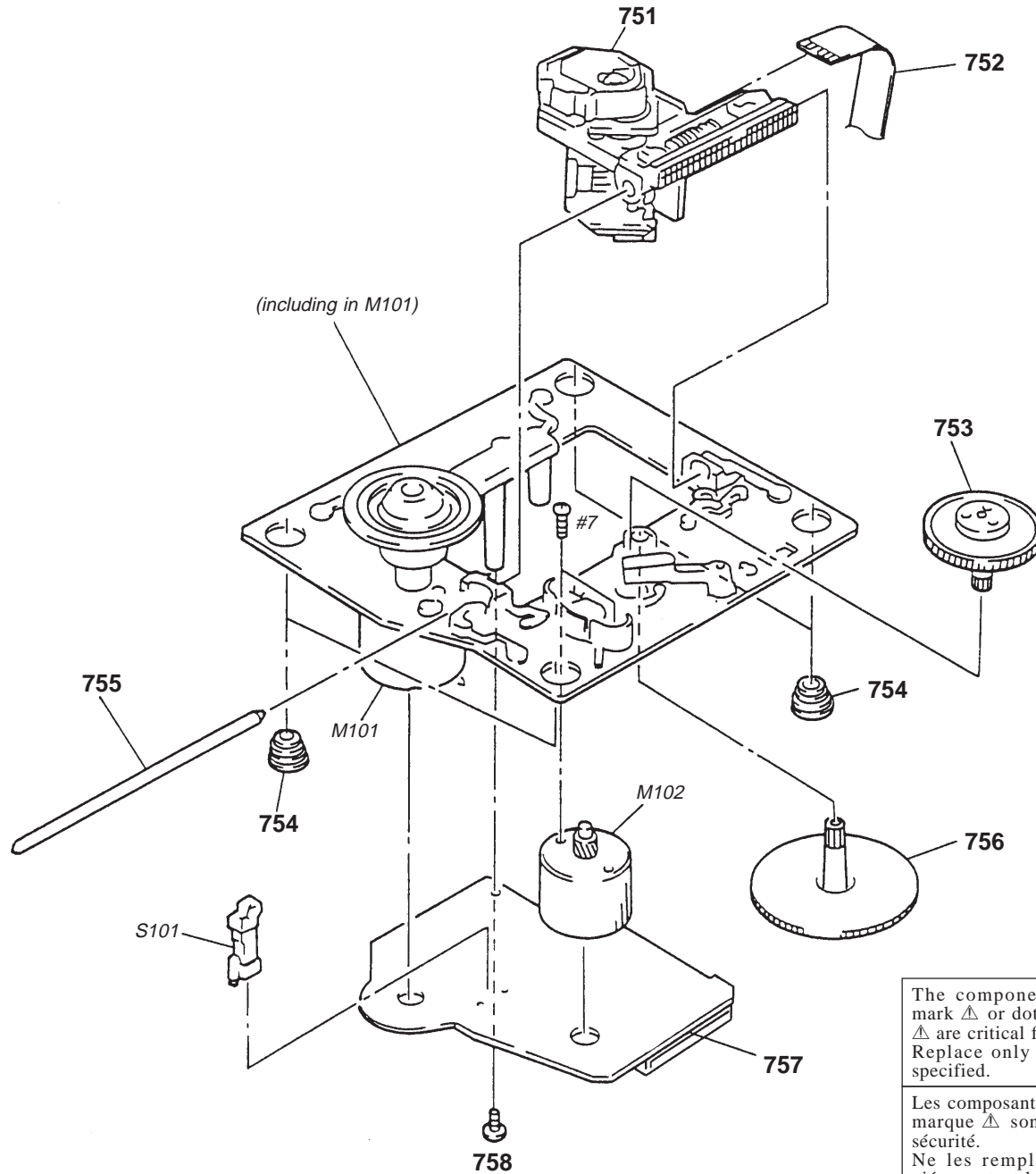

The components identified by mark Δ or dotted line with mark Δ are critical for safety. Replace only with part number specified.

Les composants identifiés par une marque Δ sont critiques pour la sécurité. Ne les remplacer que par une pièce portant le numéro spécifié.

REF.No.	Part No.	Description	Remark	REF.No.	Part No.	Description	Remark
Δ 751	8-848-367-11	OPTICAL PICK-UP KSS-213B/K-N		756	4-917-564-01	GEAR (P), FLATNESS	
752	1-769-069-11	WIRE (FLAT TYPE) (16 CORE)		* 757	A-4673-509-A	BD BOARD, COMPLETE	
753	4-917-567-21	GEAR (M)		758	4-951-620-01	SCREW (2.6 x 8), +BVTP	
754	4-951-940-01	INSULATOR (BU)		M101	X-4917-523-3	MOTOR ASSY (SPINDLE)	
755	4-917-565-01	SHAFT, SLED		M102	X-4917-504-1	MOTOR ASSY (SLED)	
				S101	1-572-085-11	SWITCH, LEAF (LIMIT)	

SECTION 6 ELECTRICAL PARTS LIST

NOTE:

The components identified by mark Δ or dotted line with mark Δ are critical for safety. Replace only with part number specified.

Les composants identifiés par une marque Δ sont critiques pour la sécurité. Ne les remplacer que par une pièce portant le numéro spécifié.

When indicating parts by reference number, please include the board name.

- Due to standardization, replacements in the parts list may be different from the parts specified in the diagrams or the components used on the set.
- Items marked “*” are not stocked since they are seldom required for routine service. Some delay should be anticipated when ordering these items.
- RESISTORS
All resistors are in ohms
METAL: Metal-film resistor
F : nonflammable
- SEMICONDUCTORS
In each case, u: μ , for example:
uA...: μ A..., uPA...: μ PA..., uPB...: μ PB...,
uPC...: μ PC..., uPD...: μ PD...
- CAPACITORS
uF : μ F
- COILS
uH : μ H
- Abbreviation
CND :Canadian model
G :German model
IT :Italian model
EE :East European model
AUS :Australian model
CH : Chinese model

REF.No.	Part No.	Description	Remark	REF.No.	Part No.	Description	Remark
*	A-4673-781-A	10 KEY BOARD, COMPLETE (CE305/CE405)		S711	1-554-303-21	SWITCH, TACTILE (SHUFFLE)	
*	A-4673-953-A	10 KEY BOARD, COMPLETE (C250Z/C350Z) *****		S712	1-554-303-21	SWITCH, TACTILE (PROGRAM)	
		< CONNECTOR >		S713	1-554-303-21	SWITCH, TACTILE (CHECK)	
				S714	1-554-303-21	SWITCH, TACTILE (CLEAR)	
				S715	1-554-303-21	SWITCH, TACTILE (REPEAT)	
* CN701	1-568-828-11	SOCKET, CONNECTOR 9P		S716	1-554-303-21	SWITCH, TACTILE (DISC 5)	
		< RESISTOR >		S717	1-554-303-21	SWITCH, TACTILE (DISC 4)	
R701	1-249-415-11	CARBON 680 5% 1/4W F		S718	1-554-303-21	SWITCH, TACTILE (DISC 3)	
R702	1-249-417-11	CARBON 1K 5% 1/4W F		S719	1-554-303-21	SWITCH, TACTILE (TIME)	
R703	1-249-419-11	CARBON 1.5K 5% 1/4W F		S720	1-554-303-21	SWITCH, TACTILE (DISC 1)	
R704	1-249-421-11	CARBON 2.2K 5% 1/4W F		S721	1-554-303-21	SWITCH, TACTILE (DISC 2)	
R705	1-249-423-11	CARBON 3.3K 5% 1/4W F		S722	1-554-303-21	SWITCH, TACTILE (7)	
R706	1-249-427-11	CARBON 6.8K 5% 1/4W F		S723	1-554-303-21	SWITCH, TACTILE (6)	
R707	1-249-431-11	CARBON 15K 5% 1/4W		S724	1-554-303-21	SWITCH, TACTILE (5)	
R708	1-249-437-11	CARBON 47K 5% 1/4W		S725	1-554-303-21	SWITCH, TACTILE (4)	
R709	1-249-415-11	CARBON 680 5% 1/4W F		S726	1-554-303-21	SWITCH, TACTILE (3)	
R710	1-249-417-11	CARBON 1K 5% 1/4W F		S727	1-554-303-21	SWITCH, TACTILE (2)	
R711	1-249-419-11	CARBON 1.5K 5% 1/4W F		S751	1-554-118-00	SWITCH, PUSH (1 KEY)(POWER)	
R712	1-249-421-11	CARBON 2.2K 5% 1/4W F		*****			
R713	1-249-423-11	CARBON 3.3K 5% 1/4W F		*	A-4673-509-A	BD BOARD, COMPLETE *****	
R714	1-249-427-11	CARBON 6.8K 5% 1/4W F				< CAPACITOR >	
R715	1-249-431-11	CARBON 15K 5% 1/4W		C101	1-163-005-11	CERAMIC CHIP 470PF	10% 50V
R716	1-249-437-11	CARBON 47K 5% 1/4W		C102	1-163-038-91	CERAMIC CHIP 0.1uF	25V
R717	1-249-415-11	CARBON 680 5% 1/4W F		C103	1-163-005-11	CERAMIC CHIP 470PF	10% 50V
R718	1-249-417-11	CARBON 1K 5% 1/4W F		C105	1-135-155-21	TANTALUM CHIP 4.7uF	10% 16V
R719	1-249-415-11	CARBON 680 5% 1/4W F		C106	1-164-346-11	CERAMIC CHIP 1uF	16V
R720	1-249-417-11	CARBON 1K 5% 1/4W F		C107	1-164-346-11	CERAMIC CHIP 1uF	16V
R721	1-249-419-11	CARBON 1.5K 5% 1/4W F		C108	1-163-035-00	CERAMIC CHIP 0.047uF	50V
R722	1-249-421-11	CARBON 2.2K 5% 1/4W F		C109	1-163-145-00	CERAMIC CHIP 0.0015uF	5% 50V
R723	1-249-423-11	CARBON 3.3K 5% 1/4W F		C110	1-163-017-00	CERAMIC CHIP 0.0047uF	5% 50V
		< SWITCH >		C111	1-163-251-11	CERAMIC CHIP 100PF	5% 50V
S701	1-554-303-21	SWITCH, TACTILE (8)		C112	1-163-038-91	CERAMIC CHIP 0.1uF	25V
S702	1-554-303-21	SWITCH, TACTILE (9)		C113	1-163-038-91	CERAMIC CHIP 0.1uF	25V
S703	1-554-303-21	SWITCH, TACTILE (10)		C115	1-126-607-11	ELECT CHIP 47uF	20% 4V
S704	1-554-303-21	SWITCH, TACTILE (>10)		C116	1-126-607-11	ELECT CHIP 47uF	20% 4V
S705	1-554-303-21	SWITCH, TACTILE (EDIT/TIME FADE) (CE305/CE405)		C117	1-126-209-11	ELECT 100uF	20% 4V
S706	1-554-303-21	SWITCH, TACTILE (PEAK SEARCH) (CE305/CE405)		C118	1-163-275-11	CERAMIC CHIP 0.001uF	5% 50V
S707	1-554-303-21	SWITCH, TACTILE (1)		C119	1-163-231-11	CERAMIC CHIP 15PF	5% 50V
S708	1-554-303-21	SWITCH, TACTILE (MUSIC SCAN)		C123	1-164-232-11	CERAMIC CHIP 0.01uF	50V
S709	1-554-303-21	SWITCH, TACTILE (FADER)					
S710	1-554-303-21	SWITCH, TACTILE (CONTINUE)					

REF.No.	Part No.	Description	Remark	REF.No.	Part No.	Description	Remark
C124	1-164-005-11	CERAMIC CHIP	0.47uF	25V	R158	1-216-111-91	METAL GLAZE 390K 5% 1/10W
C140	1-163-038-91	CERAMIC CHIP	0.1uF	25V	R159	1-216-101-00	METAL CHIP 150K 5% 1/10W
C141	1-163-038-91	CERAMIC CHIP	0.1uF	25V	R160	1-216-295-91	CONDUCTOR, CHIP (2012)
C151	1-163-237-11	CERAMIC CHIP	27PF	5% 50V	R161	1-216-308-00	METAL CHIP 4.7 5% 1/10W
C153	1-163-038-91	CERAMIC CHIP	0.1uF	25V	R162	1-216-101-00	METAL CHIP 150K 5% 1/10W
C154	1-164-336-11	CERAMIC CHIP	0.33uF	25V			< SWITCH >
C156	1-163-237-11	CERAMIC CHIP	27PF	5% 50V	S101	1-572-085-11	SWITCH, LEAF (LIMIT)
C157	1-163-145-00	CERAMIC CHIP	0.0015uF	5% 50V	*****		
C159	1-163-019-00	CERAMIC CHIP	0.0068uF	10% 50V	*	A-4673-782-A	DISPLAY BOARD, COMPLETE (CE305/CE405)
C161	1-163-038-91	CERAMIC CHIP	0.1uF	25V	*	A-4673-954-A	DISPLAY BOARD, COMPLETE (C250Z/C350Z)
		< CONNECTOR >					*****
CN101	1-770-072-11	CONNECTOR, FFC 23P					< CAPACITOR >
CN102	1-770-014-11	CONNECTOR, FFC/FPC 16P					
		< IC >					
IC101	8-752-369-78	IC CXD2545Q			C801	1-161-494-00	CERAMIC 0.022uF 25V
IC102	8-759-176-09	IC BA6392FP					< CONNECTOR >
IC103	8-752-072-45	IC CXA1821M-T6			CN801	1-764-411-11	PIN, CONNECTOR (PC BOARD) 35P
		< TRANSISTOR >					< FLUORESCENT INDICATOR >
Q101	8-729-010-08	TRANSISTOR MSB710-R			FL801	1-517-164-11	INDICATOR TUBE, FLUORESCENT
		< RESISTOR >					< IC >
R101	1-216-077-00	METAL CHIP	15K 5%	1/10W	IC801	8-759-339-53	IC GP1U28XB
R102	1-216-097-91	METAL GLAZE	100K 5%	1/10W			< RESISTOR >
R103	1-216-077-00	METAL CHIP	15K 5%	1/10W	R801	1-249-415-11	CARBON 680 5% 1/4W F
R104	1-216-085-00	METAL CHIP	33K 5%	1/10W	R802	1-249-417-11	CARBON 1K 5% 1/4W F
R105	1-216-097-91	METAL GLAZE	100K 5%	1/10W	R803	1-249-419-11	CARBON 1.5K 5% 1/4W F
R106	1-216-061-00	METAL CHIP	3.3K 5%	1/10W	R804	1-249-421-11	CARBON 2.2K 5% 1/4W F
R107	1-216-061-00	METAL CHIP	3.3K 5%	1/10W	R805	1-249-423-11	CARBON 3.3K 5% 1/4W F
R108	1-216-073-00	METAL CHIP	10K 5%	1/10W	R806	1-249-427-11	CARBON 6.8K 5% 1/4W F
R109	1-216-121-91	METAL GLAZE	1M 5%	1/10W	R807	1-249-431-11	CARBON 15K 5% 1/4W
R110	1-216-025-91	METAL GLAZE	100 5%	1/10W	R808	1-247-871-11	CARBON 47K 5% 1/4W
R112	1-216-049-91	METAL GLAZE	1K 5%	1/10W	R809	1-249-427-11	CARBON 6.8K 5% 1/4W F
R123	1-216-073-00	METAL CHIP	10K 5%	1/10W	R810	1-249-431-11	CARBON 15K 5% 1/4W
R124	1-216-097-91	METAL GLAZE	100K 5%	1/10W			(CE305/CE405)
R125	1-216-049-91	METAL GLAZE	1K 5%	1/10W			< SWITCH >
R126	1-216-049-91	METAL GLAZE	1K 5%	1/10W	S801	1-554-303-21	SWITCH, TACTILE (DISC SKIP)
R127	1-216-049-91	METAL GLAZE	1K 5%	1/10W	S802	1-554-303-21	SWITCH, TACTILE (≡ OPEN/CLOSE)
R131	1-216-037-00	METAL CHIP	330 5%	1/10W	S803	1-554-303-21	SWITCH, TACTILE (■)
R135	1-216-295-91	CONDUCTOR, CHIP	(2012)		S804	1-554-303-21	SWITCH, TACTILE (▣)
R136	1-216-295-91	CONDUCTOR, CHIP	(2012)		S805	1-554-303-21	SWITCH, TACTILE (▷)
R137	1-216-295-91	CONDUCTOR, CHIP	(2012)		S806	1-554-303-21	SWITCH, TACTILE (▷▷, AMS)
R138	1-216-295-91	CONDUCTOR, CHIP	(2012)		S807	1-554-303-21	SWITCH, TACTILE (◁◁, AMS)
R141	1-216-089-91	METAL GLAZE	47K 5%	1/10W	S808	1-554-303-21	SWITCH, TACTILE (◀◀)
R142	1-216-081-00	METAL CHIP	22K 5%	1/10W	S809	1-554-303-21	SWITCH, TACTILE (▶▶)
R143	1-216-103-91	METAL GLAZE	180K 5%	1/10W	S810	1-554-303-21	SWITCH, TACTILE (EX-CHANGE)
R144	1-216-103-91	METAL GLAZE	180K 5%	1/10W	S811	1-554-303-21	SWITCH, TACTILE (DISC CHECK) (CE305/CE405)
R146	1-216-073-00	METAL CHIP	10K 5%	1/10W			
R147	1-216-081-00	METAL CHIP	22K 5%	1/10W			
R148	1-216-001-00	METAL CHIP	10 5%	1/10W			
R149	1-216-003-11	METAL GLAZE	12 5%	1/10W			

LOADING

MAIN

REF.No.	Part No.	Description	Remark

*	1-659-738-11	LOADING BOARD *****	
		< MOTOR >	
M802	A-4660-914-A	MOTOR ASSY, LOADING (LOADING)	

*	A-4673-784-A	MAIN BOARD, COMPLETE (US,CND,CH) *****	
*	A-4673-785-A	MAIN BOARD, COMPLETE ***** (EXCEPT US,CND,E,CH)	
*	A-4673-786-A	MAIN BOARD, COMPLETE (E) *****	
*	4-922-525-01	HEAT SINK	
	7-685-871-01	SCREW +BVTT 3X6 (S)	
		< CAPACITOR >	
C301	1-162-199-31	CERAMIC 10PF	5% 50V
C302	1-162-199-31	CERAMIC 10PF	5% 50V
C303	1-164-159-11	CERAMIC 0.1uF	50V
C305	1-124-443-00	ELECT 100uF	20% 10V
C306	1-124-442-00	ELECT 330uF	20% 6.3V
C315	1-161-494-00	CERAMIC 0.022uF	25V
C316	1-164-159-11	CERAMIC 0.1uF	50V
C317	1-161-494-00	CERAMIC 0.022uF	25V
C320	1-162-290-31	CERAMIC 470PF	10% 50V
C401	1-162-282-31	CERAMIC 100PF	10% 50V
C402	1-162-215-31	CERAMIC 47PF	5% 50V
C403	1-162-215-31	CERAMIC 47PF	5% 50V
C404	1-130-479-00	MYLAR 0.0047uF	5% 50V
C405	1-130-472-00	MYLAR 0.0012uF	5% 50V
C406	1-124-443-00	ELECT 100uF	20% 10V
C407	1-161-494-00	CERAMIC 0.022uF	25V
C408	1-104-664-11	ELECT 47uF	20% 16V
C410	1-162-290-31	CERAMIC 470PF	10% 50V
C412	1-164-159-11	CERAMIC 0.1uF	50V
C501	1-162-282-31	CERAMIC 100PF	10% 50V
C502	1-162-215-31	CERAMIC 47PF	5% 50V
C503	1-162-215-31	CERAMIC 47PF	5% 50V
C504	1-130-479-00	MYLAR 0.0047uF	5% 50V
C505	1-130-472-00	MYLAR 0.0012uF	5% 50V
C506	1-124-443-00	ELECT 100uF	20% 10V
		(US,CND,E,CH)	
C506	1-124-994-11	ELECT 100uF	20% 10V
		(AEP,UK,G,IT,EE,AUS)	
C507	1-161-494-00	CERAMIC 0.022uF	25V
C508	1-104-664-11	ELECT 47uF	20% 16V
C509	1-126-962-11	ELECT 3.3uF	20% 50V
C510	1-162-290-31	CERAMIC 470PF	10% 50V

REF.No.	Part No.	Description	Remark
C512	1-164-159-11	CERAMIC 0.1uF	50V
C602	1-126-944-11	ELECT 3300uF	20% 16V
C603	1-126-942-61	ELECT 1000uF	20% 16V
C604	1-126-963-11	ELECT 4.7uF	20% 50V
C605	1-126-963-11	ELECT 4.7uF	20% 50V
C605	1-126-163-11	ELECT 4.7uF	20% 50V
C606	1-126-963-11	ELECT 4.7uF	20% 50V
C607	1-126-941-11	ELECT 470uF	20% 6.3V
C608	1-104-666-11	ELECT 220uF	20% 10V
C609	1-124-918-11	ELECT 47uF	20% 63V
C610	1-124-907-11	ELECT 10uF	20% 50V
C614	1-104-665-11	ELECT 100uF	20% 16V
C616	1-161-494-00	CERAMIC 0.022uF	25V
C619	1-104-664-11	ELECT 47uF	20% 16V
C620	1-161-494-00	CERAMIC 0.022uF	25V
C622	1-162-306-11	CERAMIC 0.01uF	20% 16V
C624	1-161-494-00	CERAMIC 0.022uF	25V
C625	1-161-494-00	CERAMIC 0.022uF	25V
C626	1-161-494-00	CERAMIC 0.022uF	25V
C628	1-104-664-11	ELECT 47uF	20% 16V
C648	1-161-494-00	CERAMIC 0.022uF	25V
C649	1-161-494-00	CERAMIC 0.022uF	25V
C651	1-104-664-11	ELECT 47uF	20% 16V
C652	1-104-664-11	ELECT 47uF	20% 16V
C653	1-136-165-00	FILM 0.1uF	5% 50V
C654	1-136-165-00	FILM 0.1uF	5% 50V
		< CONNECTOR >	
CN401	1-750-640-11	CONNECTOR, FFC/FPC 23P	
CN402	1-764-411-11	PIN, CONNECTOR (PC BOARD) 35P	
* CN403	1-568-852-11	SOCKET, CONNECTOR 9P	
* CN404	1-568-825-11	SOCKET, CONNECTOR 6P	
* CN601	1-573-047-11	PIN, CONNECTOR (PC BOARD) 2P	
		< DIODE >	
D302	8-719-987-63	DIODE 1N4148M	
D601	8-719-200-82	DIODE 11ES2	
D602	8-719-200-82	DIODE 11ES2	
D603	8-719-200-82	DIODE 11ES2	
D604	8-719-200-82	DIODE 11ES2	
D605	8-719-200-82	DIODE 11ES2	
D606	8-719-923-60	DIODE MTZJ-T-77-9.1A	
D608	8-719-987-63	DIODE 1N4148M	
D609	8-719-010-34	DIODE UZ-4.7BSC	
		< IC >	
IC301	8-759-362-47	IC CXD8567AM	
IC303	8-752-867-57	IC CXP82320-064Q	
IC304	8-759-821-32	IC CXA1291P	
IC401	8-759-145-58	IC uPC4558C	
IC501	8-759-145-58	IC uPC4558C	
IC601	8-759-061-65	IC LA5602	
IC602	8-749-011-78	IC BA17807T	
IC603	8-759-633-42	IC M5293L	

REF.No.	Part No.	Description	Remark	REF.No.	Part No.	Description	Remark
		< JACK >		△ R306	1-212-942-00	FUSIBLE 2.2 5% 1/2W	F
J301	1-770-719-11	JACK, PIN 2P (LINE OUT)		R308	1-249-429-11	CARBON 10K 5% 1/4W	
		< COIL >		R309	1-249-417-11	CARBON 1K 5% 1/4W	F
L301	1-410-503-11	INDUCTOR 3.3uH		R310	1-249-417-11	CARBON 1K 5% 1/4W	F
L302	1-410-503-11	INDUCTOR 3.3uH		R311	1-249-425-11	CARBON 4.7K 5% 1/4W	F
L303	1-410-503-11	INDUCTOR 3.3uH		R312	1-249-437-11	CARBON 47K 5% 1/4W	
L304	1-410-503-11	INDUCTOR 3.3uH		R313	1-249-417-11	CARBON 1K 5% 1/4W	
L305	1-410-397-21	FERRITE BEAD INDUCTOR		R314	1-249-425-11	CARBON 4.7K 5% 1/4W	F
L306	1-410-397-21	FERRITE BEAD INDUCTOR		R315	1-249-425-11	CARBON 4.7K 5% 1/4W	F
L401	1-410-503-11	INDUCTOR 3.3uH		R316	1-249-425-11	CARBON 4.7K 5% 1/4W	F
L501	1-410-503-11	INDUCTOR 3.3uH		R317	1-249-427-11	CARBON 6.8K 5% 1/4W	F
L601	1-412-473-21	INDUCTOR 0uH		R318	1-249-427-11	CARBON 6.8K 5% 1/4W	F
L603	1-412-473-21	INDUCTOR 0uH		R319	1-249-427-11	CARBON 6.8K 5% 1/4W	F
L604	1-412-473-21	INDUCTOR 0uH		R320	1-249-427-11	CARBON 6.8K 5% 1/4W	F
L605	1-410-503-11	INDUCTOR 3.3uH		R321	1-249-429-11	CARBON 10K 5% 1/4W	
L606	1-410-397-21	FERRITE BEAD INDUCTOR		R322	1-249-429-11	CARBON 10K 5% 1/4W	
L607	1-410-503-11	INDUCTOR 3.3uH		R323	1-249-441-11	CARBON 100K 5% 1/4W	
L608	1-410-503-11	INDUCTOR 3.3uH		R324	1-249-429-11	CARBON 10K 5% 1/4W	
L609	1-412-473-21	INDUCTOR 0uH		R330	1-249-427-11	CARBON 6.8K 5% 1/4W	F
		< TRANSISTOR >		R403	1-249-436-11	CARBON 39K 5% 1/4W	
Q201	8-729-119-78	TRANSISTOR 2SC2785-HFE		R404	1-249-436-11	CARBON 39K 5% 1/4W	
Q402	8-729-141-26	TRANSISTOR 2SC3622A-LK		R405	1-249-431-11	CARBON 15K 5% 1/4W	
Q404	8-729-119-78	TRANSISTOR 2SC2785-HFE		R406	1-249-431-11	CARBON 15K 5% 1/4W	
Q502	8-729-141-26	TRANSISTOR 2SC3622A-LK		R407	1-249-437-11	CARBON 47K 5% 1/4W	
Q503	8-729-900-65	TRANSISTOR DTA144ES		R408	1-249-437-11	CARBON 47K 5% 1/4W	
Q601	8-729-119-76	TRANSISTOR 2SA1175-HFE		R409	1-249-419-11	CARBON 1.5K 5% 1/4W	F
		< RESISTOR >		R410	1-249-419-11	CARBON 1.5K 5% 1/4W	F
R205	1-249-430-11	CARBON 12K 5% 1/4W		R411	1-247-887-00	CARBON 220K 5% 1/4W	
R206	1-249-429-11	CARBON 10K 5% 1/4W		R412	1-249-417-11	CARBON 1K 5% 1/4W	F
R251	1-249-440-11	CARBON 82K 5% 1/4W		R416	1-249-425-11	CARBON 4.7K 5% 1/4W	F
R252	1-249-440-11	CARBON 82K 5% 1/4W		R503	1-249-436-11	CARBON 39K 5% 1/4W	
R253	1-249-441-11	CARBON 100K 5% 1/4W		R504	1-249-436-11	CARBON 39K 5% 1/4W	
R254	1-249-441-11	CARBON 100K 5% 1/4W		R505	1-249-431-11	CARBON 15K 5% 1/4W	
R255	1-249-393-11	CARBON 10 5% 1/4W	F	R506	1-249-431-11	CARBON 15K 5% 1/4W	
R256	1-249-427-11	CARBON 6.8K 5% 1/4W	F	R507	1-249-437-11	CARBON 47K 5% 1/4W	
R257	1-247-889-00	CARBON 270K 5% 1/4W		R508	1-249-437-11	CARBON 47K 5% 1/4W	
R258	1-247-889-00	CARBON 270K 5% 1/4W		R509	1-249-419-11	CARBON 1.5K 5% 1/4W	F
R259	1-247-860-11	CARBON 16K 5% 1/4W		R510	1-249-419-11	CARBON 1.5K 5% 1/4W	F
R260	1-247-883-00	CARBON 150K 5% 1/4W		R511	1-247-887-00	CARBON 220K 5% 1/4W	
R261	1-249-431-11	CARBON 15K 5% 1/4W		R512	1-249-417-11	CARBON 1K 5% 1/4W	F
R262	1-249-382-11	CARBON 1.2 5% 1/6W	F	R516	1-249-425-11	CARBON 4.7K 5% 1/4W	F
R263	1-249-382-11	CARBON 1.2 5% 1/6W	F	R517	1-249-441-11	CARBON 100K 5% 1/4W	
R264	1-249-393-11	CARBON 10 5% 1/4W	F	R601	1-249-435-11	CARBON 33K 5% 1/4W	
R301	1-249-424-11	CARBON 3.9K 5% 1/4W	F	R602	1-249-429-11	CARBON 10K 5% 1/4W	
R302	1-247-807-31	CARBON 100K 5% 1/4W		R603	1-249-438-11	CARBON 56K 5% 1/4W	
R303	1-249-411-11	CARBON 330 5% 1/4W	F	R604	1-249-429-11	CARBON 10K 5% 1/4W	
△ R305	1-212-942-00	FUSIBLE 2.2 5% 1/2W	F	R607	1-249-411-11	CARBON 330 5% 1/4W	
		< SWITCH >					
				△ S601	1-572-675-11	SWITCH, POWER VOLTAGE CHANGE (VOLTAGE SLECTOR) (E)	

The components identified by mark △ or dotted line with mark △ are critical for safety. Replace only with part number specified.	Les composants identifiés par une marque △ sont critiques pour la sécurité. Ne les remplacer que par une pièce portant le numéro spécifié.
--	--

CDP-C250Z/C350Z/CE305/CE405

MAIN	SENSOR	TABLE MOTOR
-------------	---------------	--------------------

REF.No.	Part No.	Description	Remark
		< VIBRATOR >	
X301	1-579-833-21	VIBRATOR, CRYSTAL (33MHz)	
X401	1-579-175-11	VIBRATOR, CERAMIC (10MHz)	

*	1-659-737-11	SENSOR BOARD *****	
		< CONNECTOR >	
CN851	1-573-383-11	PIN, CONNECTOR (PC BOARD) 2P	
CN852	1-750-243-11	SOCKET, CONNECTOR 6P	
		< DIODE >	
D851	8-749-924-18	DIODE PHOTO INTERRUPTER RPI-1391	
D852	8-749-924-30	DIODE PHOTO REFLECTOR GP2S28	
		< RESISTOR >	
R851	1-249-416-11	CARBON 820 5% 1/4W F	
R852	1-249-406-11	CARBON 120 5% 1/4W F	

*	1-647-364-11	TABLE MOTOR BOARD *****	
		< MOTOR >	
M801	A-4660-525-A	MOTOR ASSY, ROTARY (TABLE)	

		MISCELLANEOUS *****	
7	1-776-125-11	WIRE (FLAT TYPE) (35 CORE)	
9	1-776-124-11	WIRE (FLAT TYPE) (9 CORE)	
△ 59	1-558-943-61	CORD POWER (E)	
△ 59	1-575-651-21	CORD POWER (AEP,CH,G,EE)	
△ 59	1-590-926-11	CORD POWER (US,CND)	
△ 59	1-696-845-11	CORD POWER (AUS)	
△ 59	1-751-529-11	CORD POWER (UK)	
△ 68	1-569-007-11	ADAPTOR, CONVERSION 2P (E)	
△ 68	1-569-008-11	ADAPTOR, CONVERSION 2P (CH)	
72	1-751-052-11	WIRE (FLAT TYPE) (6 CORE)	
105	1-466-996-11	ENCODER, ROTARY	
109	1-765-443-11	WIRE (FLAT TYPE) (23 CORE)	
△ 751	8-848-367-11	OPTICAL PICK-UP KSS-213B-K/N	
△ 752	1-769-069-11	WIRE (FLAT TYPE) (16 CORE)	
M101	X-4917-523-3	MOTOR ASSY (SPINDLE)	

REF.No.	Part No.	Description	Remark
M102	X-4917-504-1	MOTOR ASSY (SLED)	
M801	A-4660-525-A	MOTOR ASSY, ROTARY (TABLE)	
M802	A-4660-914-A	MOTOR ASSY, LOADING (LOADING)	
△ S601	1-572-675-11	SWITCH, POWER VOLTAGE CHANGE (VOLTAGE SELECTOR) (E)	
S101	1-572-085-11	SWITCH, LEAF (LIMIT)	
△ T601	1-423-830-11	TRANSFORMER, POWER (US,CND)	
△ T601	1-429-394-11	TRANSFORMER, POWER (EXCEPT US,CND,E)	
△ T601	1-429-395-11	TRANSFORMER, POWER (E)	

		ACCESSORIES & PACKING MATERIALS *****	
	1-473-519-11	REMOTE COMMANDER (RM-DC41) (C350Z/CE405)	
	4-941-762-11	COVER (MLY), BATTERY (For RM-DC41)	
	1-558-271-11	CORD, CONNECTION (AUDIO 108cm)	
	3-810-585-11	MANUAL, INSTRUCTION (ENGLISH,FRENCH,SPANISH,SWEDISH, CHINESE) (CND,AEP,E,CH,UK)	
	3-810-585-21	MANUAL, INSTRUCTION (ENGLISH) (US,AUS)	
	3-810-585-31	MANUAL, INSTRUCTION (GERMAN,DUTCH,PORTUGUESE,ITALIAN) (AEP,G)	
	3-810-585-41	MANUAL, INSTRUCTION (SWEDISH,FINISH,DANNISH) (CE405:AEP)	
	3-810-585-51	MANUAL, INSTRUCTION (ENGLISH,RUSSIAN,POLISH) (EE)	
*	4-979-552-01	CUSHION (F)	
*	4-979-553-01	CUSHION (R)	
*	4-979-554-01	INDIVIDUAL CARTON (CE405/CE305:AEP)	
*	4-979-759-01	INDIVIDUAL CARTON (CE305)	
*	4-981-602-01	INDIVIDUAL CARTON (C350Z)	
*	4-981-603-01	INDIVIDUAL CARTON (C250Z)	

		HARDWARE LIST *****	
#1	7-685-647-79	SCREW +BVTP 3x10 TYPE2 N-S	
#2	7-682-548-04	SCREW +BVTT 3x8 (S)	
#3	7-685-648-79	SCREW (M3 x 12) TAPPING	
#4	7-685-646-79	SCREW +BVTP 3x8 TYPE2 N-S	
#5	7-621-772-00	SCREW +B 2x3	
#6	7-685-134-19	SCREW +PTPWH 2.6x8 (TYPE2)	
#7	7-621-255-15	SCREW +P 2x3	
#8	7-685-871-01	SCREW +BVTT 3x6 (S)	

The components identified by mark △ or dotted line with mark △ are critical for safety. Replace only with part number specified.	Les composants identifiés par une marque △ sont critiques pour la sécurité. Ne les remplacer que par une pièce portant le numéro spécifié.
--	--

CDP-C250Z/C350Z/CE305/CE405

SONY SERVICE MANUAL

US Model
Canadian Model
CDP-C250Z/C350Z/CE305/CE405

AEP Model
CDP-CE305/CE405

UK Model
CDP-CE405

E Model
Australian Model
Chinese Model
CDP-CE305/CE405

SUPPLEMENT-1

File this supplement with the service manual.

Subject : 1. CORRECTION
2. MODEL ADDITION (CDP-C250Z/C350Z : Canadian model)
3. PARTS CHANGED
4. TEST MODE ADDITION

(ECN-CD501868)

1. CORRECTION

• Correct your Service manual as shown below.

👉 : indicates corrected portion.

Page	INCORRECT	CORRECT
21	<p>[MAIN BOARD]</p>	<p>[MAIN BOARD]</p>
30	<p>Ref. No. Part No. Description Remark</p> <p>*** EXPLODED VIEWS *** Not supplied Not supplied</p>	<p>Ref. No. Part No. Description Remark</p> <p>*** EXPLODED VIEWS ***</p> <p>74 4-981-731-01 CUSHION (U/D) 75 4-981-731-11 CUSHION (U/D)</p>
36	<p>Ref. No. Part No. Description Remark</p> <p>*** ACCESSORIES & PACKING MATERIALS ***</p> <p>* 4-979-554-01 INDIVIDUAL CARTON (CE405/CE305 : AEP)</p> <p>* 4-979-759-01 INDIVIDUAL CARTON (CE305)</p>	<p>Ref. No. Part No. Description Remark</p> <p>*** ACCESSORIES & PACKING MATERIALS ***</p> <p>* 4-979-554-01 INDIVIDUAL CARTON (CE405 : EXCEPT E, CH)</p> <p>* 4-979-759-01 INDIVIDUAL CARTON (CE305 : EXCEPT E, CH)</p> <p>* 4-981-352-01 INDIVIDUAL CARTON (CE405 : E, CH)</p> <p>* 4-981-354-01 INDIVIDUAL CARTON (CE305 : E, CH)</p>

2. MODEL ADDITION (CDP-C250Z/C350Z : Canadian model)

- For detailed Canadian model, refer to US model.

Difference table

Page	C250Z/C350Z : US model				C250Z/C350Z : Canadian model			
	Ref. No.	Part No.	Description	Remark	Ref. No.	Part No.	Description	Remark
29	* 71	4-978-490-71	PANEL, BACK (C250Z : US)		* 71	4-978-767-81	PANEL, BACK (C250Z : Canadian)	
	* 71	4-978-490-81	PANEL, BACK (C350Z : US)		* 71	4-978-767-91	PANEL, BACK (C350Z : Canadian)	

3. PARTS CHANGED

- The following parts have been changed as below.

Page	FORMER				NEW			
	Ref. No.	Part No.	Description	Remark	Ref. No.	Part No.	Description	Remark
28	14	4-933-601-01	FOOT		14	X-4946-618-1	FOOT ASSY	

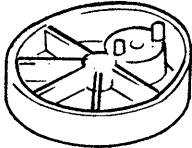
- The former parts and the new parts have its own way to install.

How to install

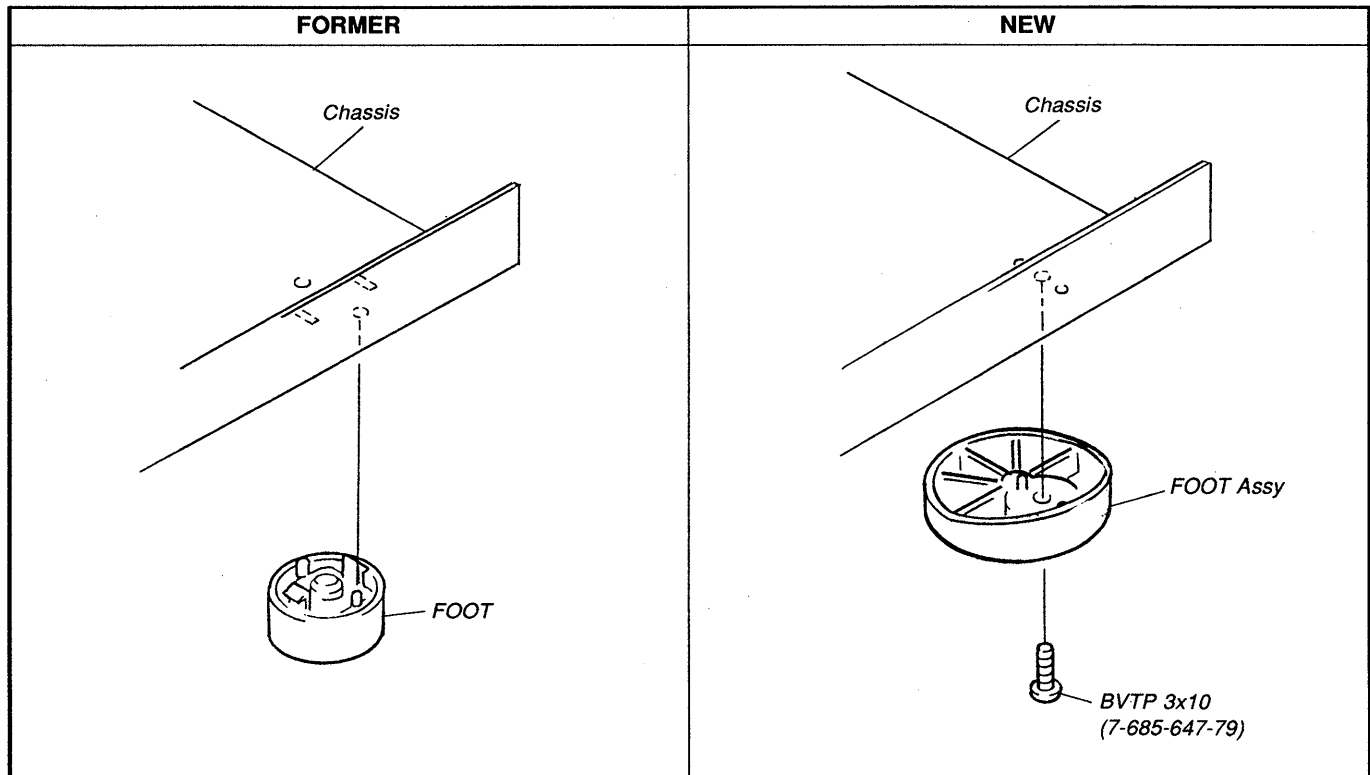

4. TEST MODE ADDITION

Fluorescent Indicator Tube Full Lighting and Key Check Mode

1. Connect the test point TP1 (AFADJ) of the main board to ground.
2. Turn on the power switch.
3. The fluorescent indicator tubes will light up fully.
4. Set the key check mode by pressing any button.
In the key check mode, each time a button is pressed, the count up display will count up. However, the display will not count up for buttons that have already been pressed once.
The number of the button pressed will be displayed in the indicator, only while the button is being pressed.
5. To exit the test mode, disconnect the power plug from the outlet.

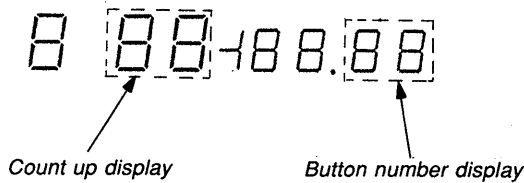

[MAIN BOARD] (Conductor Side)

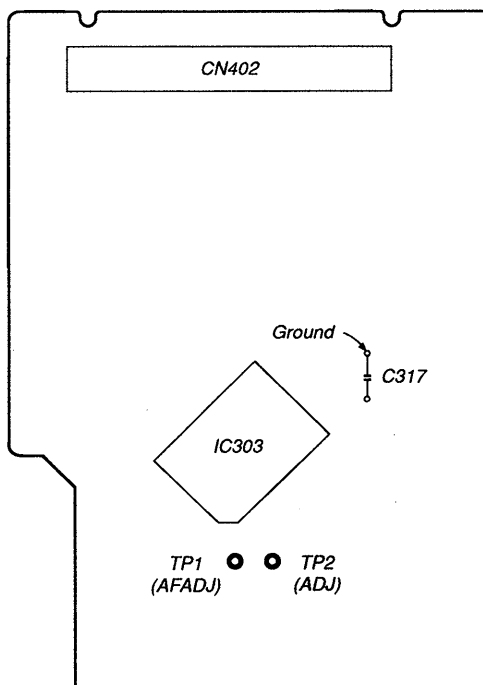

Button	Button number display																						
1	15																						
2	41																						
3	40																						
4	39																						
5	38																						
6	37																						
7	36																						
8	09																						
9	10																						
10	11																						
>10	12																						
EDIT/TIME FADE	13																						
PEAK SEARCH	14																						
DISC CHECK	43																						
EX-CHANGE	42																						
DISC SKIP	45																						
OPEN/CLOSE ≡	46																						
▶▶	53																						
◀◀	52																						
AMS ▶▶◀	50																						
AMS ◀◀▶	51																						
REPEAT	23																						
CLEAR	22																						
CHECK	21																						
PROGRAM	20																						
SHUFFLE	19																						
CONTINUE	18																						
DISC 1	28																						
DISC 2	29																						
DISC 3	26																						
DISC 4	25																						
DISC 5	24																						
MUSIC SCAN	16																						
FADER	17																						
TIME	27																						
■	Fluorescent indicator fully lit.																						
□□	The following displays switch alternately. <table style="margin-left: 20px;"> <tr> <td>1</td><td>3</td><td>5</td> <td>2</td><td>4</td> </tr> <tr> <td>7</td><td>9</td><td></td> <td>6</td><td>8</td><td>10</td> </tr> <tr> <td>11</td><td>13</td><td>15</td> <td>12</td><td>14</td> </tr> <tr> <td>18</td><td>20</td><td></td> <td>16</td><td>17</td><td>19</td> </tr> </table>	1	3	5	2	4	7	9		6	8	10	11	13	15	12	14	18	20		16	17	19
1	3	5	2	4																			
7	9		6	8	10																		
11	13	15	12	14																			
18	20		16	17	19																		
▷	The part of the display on the fluorescent indicator tube blinks repeatedly.																						

CDP-C250Z/C350Z/CE305/CE405

SONY

SERVICE MANUAL

US Model
Canadian Model
CDP-C250Z/C350Z/CE305/CE405

AEP Model
CDP-CE305/CE405

UK Model
CDP-CE405

E Model
Australian Model
Chinese Model
CDP-CE305/CE405

CORRECTION-1

Correct your service manual as shown below.

____ (Under line) : indicates corrected portion.

Page	INCORRECT			CORRECT		
	Ref. No.	Part No.	Description	Ref. No.	Part No.	Description
34	IC303	8-752-867-57	IC CXP82320-064Q	IC303	<u>8-752-864-57</u>	IC CXP82320-064Q

(RPC-96021)

CDP-C250Z/C350Z/CE305/CE405

SONY.

SERVICE MANUAL

*US Model
Canadian Model
CDP-C250Z/C350Z/CE305/CE405*

*AEP Model
CDP-CE305/CE405*

*UK Model
CDP-CE405*

*E Model
Australian Model
Chinese Model
CDP-CE305/CE405*

CORRECTION-2

Correct your service manual as shown below.

 : indicates corrected portion.

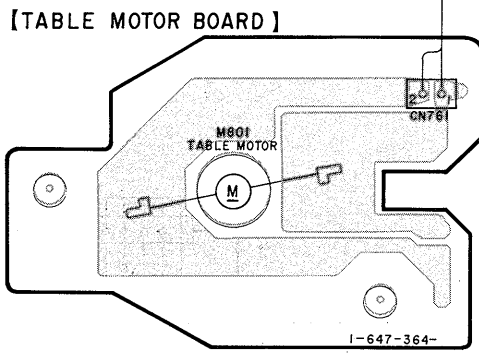
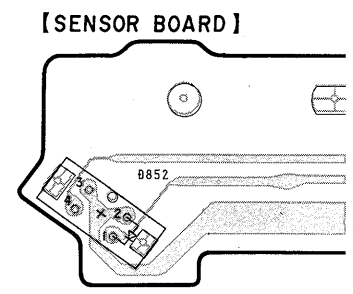
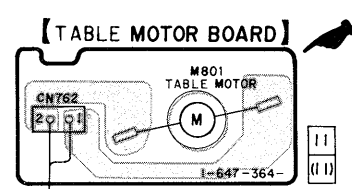
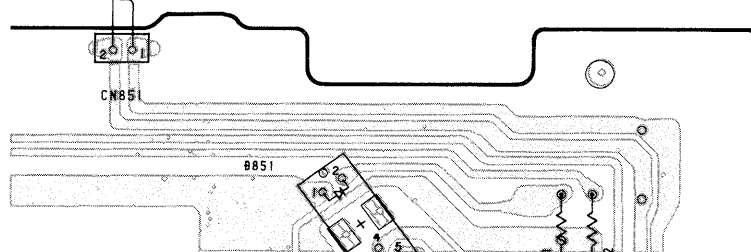
Page	INCORRECT
17	<p>Location : H-J, 1-3</p> <div data-bbox="399 903 877 1260"><p>[TABLE MOTOR BOARD]</p><p>M801 TABLE MOTOR</p><p>1-647-364-</p></div> <div data-bbox="1053 903 1404 1197"><p>[SENSOR BOARD]</p><p>B852</p></div>
CORRECT	
	<p>Location : H-J, 6-8</p> <div data-bbox="558 1407 909 1596"><p>[TABLE MOTOR BOARD]</p><p>M801 TABLE MOTOR</p><p>1-647-364-</p></div> <div data-bbox="494 1659 1244 1911"><p>CN851</p><p>B851</p></div>

✖ : indicates corrected portion.

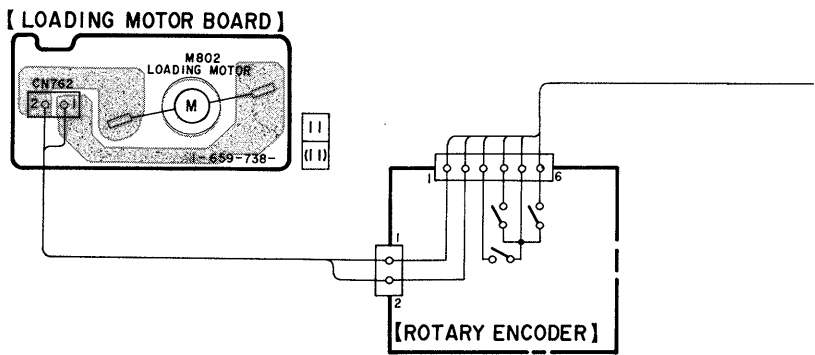
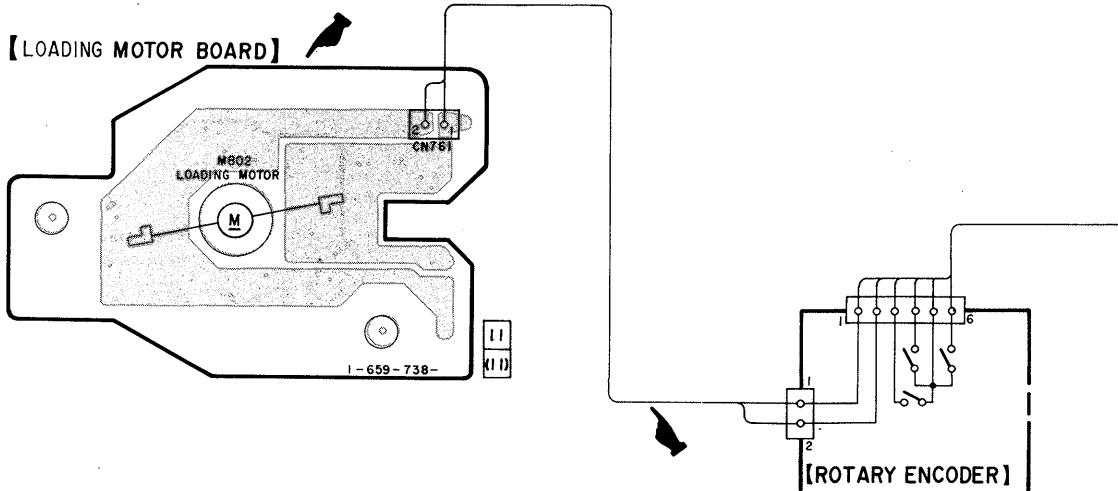
Page	INCORRECT
18	<p data-bbox="199 241 438 273">Location : H-J, 12-16</p>  <p data-bbox="510 304 798 336">【LOADING MOTOR BOARD】</p> <p data-bbox="893 619 1117 651">【ROTARY ENCODER】</p>
CORRECT	
	<p data-bbox="199 766 438 798">Location : H-J, 12-16</p>  <p data-bbox="215 850 494 882">【LOADING MOTOR BOARD】</p> <p data-bbox="1013 1270 1236 1302">【ROTARY ENCODER】</p>

