

CDP-CX250

SERVICE MANUAL

*US Model
Canadian Model
AEP Model
E Model
Australian Model*



Model Name Using Similar Mechanism	NEW
CD Mechanism Type	CDM-40
Base Unit Type	KSM-213BKN/M-N
Optical Pick-up Type	KSS-213B/S-N

SPECIFICATIONS

Compact disc player

Laser	Semiconductor laser ($\lambda = 780 \text{ nm}$) Emission duration: continuous
Laser output	Max 44.6 μW * * This output is the value measured at a distance of 200 mm from the objective lens surface on the Optical Pick-up block with 7 mm aperture.
Frequency response	20 Hz to 20 kHz $\pm 0.5 \text{ dB}$
Signal-to-noise ratio	More than 107 dB
Dynamic range	More than 98 dB
Harmonic distortion	Less than 0.0035%
Channel separation	More than 100 dB

Outputs

	Jack type	Maximum output level	Load impedance
LINE OUT	Phono jacks	2 V (at 50 kilohms)	Over 10 kilohms
DIGITAL OUT (OPTICAL)	Optical output connector	-18 dBm	Wave length: 660 nm

General

Power requirements

Where purchased	Power requirements
USA, Canada	120 V AC, 60 Hz
Europe and Singapore	220V-230V AC, 50Hz
E	110V-120V or 230-240V AC, adjustable, 50/60 Hz
Australia	240 V AC, 50 Hz

Power consumption 14 W

Dimensions (approx.) (w/h/d)
When the front cover is closed
430 x 200 x 480 mm (17 x 7 7/8 x 19 in.) incl. projecting parts
When the front cover is open
430 x 200 x 600 mm (17 x 7 7/8 x 23 5/8 in.) incl. projecting parts

Mass (approx.) 9.0 kg (19 lbs 14 oz)

Supplied accessories

Audio cord (2 phono plugs - 2 phono plugs) (1)
Remote commander (remote) (1)
Sony SUM-3 (NS) batteries (2)
CD booklet holders (2)
Label (1)

Design and specifications are subject to change without notice.



COMPACT DISC PLAYER
SONY®

TABLE OF CONTENTS

1. SERVICING NOTE	3
2. GENERAL	4
3. DISASSEMBLY	
3-1. Front Panel Assembly	12
3-2. Back Panel Assembly	12
3-3. Table Assembly	13
3-4. Mechanism Deck Assembly	13
3-5. Base Unit Assembly	14
4. TEST MODE	15
5. ADJUSTMENTS	
5-1. Mechanical Adjustment	16
5-2. Electrical Block Checking	22
6. DIAGRAMS	
6-1. Circuit Boards Location	24
6-2. IC Pin Function	
• IC101 Digital Servo, Digital Signal Processor (CXD2545Q)	25
• IC303 System Control (CXP84332-Q27Q)	28
6-3. Block Diagram	31
6-4. Printed Wiring Board — BD, DISP Section —	35
6-5. Schematic Diagram — BD, DISP Section —	39
6-6. Printed Wiring Board — MAIN Section —	43
6-7. Schematic Diagram — MAIN Section —	47
6-8. IC Block Diagrams	51
7. EXPLODED VIEWS	
7-1. Case and Back Panel Section	54
7-2. Disc table Section	55
7-3. Front panel Section	56
7-4. Mechanism Section-1 (CDM-40)	57
7-5. Mechanism Section-2 (CDM-40)	58
7-6. Base Unit Section-1 (KSM-213BKN/M-N)	59
7-7. Base Unit Section-2 (KSM-213BKN/M-N)	60
8. ELECTRICAL PARTS LIST	61

Notes on chip component replacement

- Never reuse a disconnected chip component.
- Notice that the minus side of a tantalum capacitor may be damaged by heat.

Flexible Circuit Board Repairing

- Keep the temperature of soldering iron around 270°C during repairing.
- Do not touch the soldering iron on the same conductor of the circuit board (within 3 times).
- Be careful not to apply force on the conductor when soldering or unsoldering.

MODEL IDENTIFICATION — BACK PANEL —

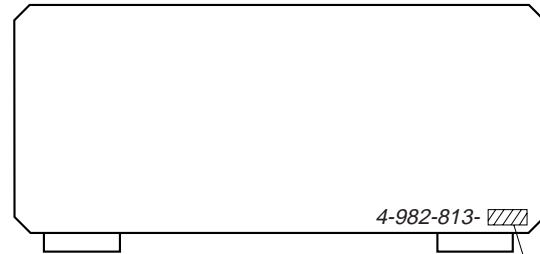

- 4-982-813-
- | | |
|-------------------|------------------------------|
| US Model | : 0 <input type="checkbox"/> |
| Canadian Model | : 1 <input type="checkbox"/> |
| AEP, German Model | : 2 <input type="checkbox"/> |
| E Model | : 3 <input type="checkbox"/> |
| Singapore Model | : 4 <input type="checkbox"/> |
| Austrarian Model | : 5 <input type="checkbox"/> |

CAUTION

Use of controls or adjustments or performance of procedures other than those specified herein may result in hazardous radiation exposure.

The laser component in this product is capable of emitting radiation exceeding the limit for Class 1.

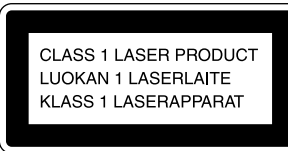

This appliance is classified as a CLASS 1 LASER product. The CLASS 1 LASER PRODUCT MARKING is located on the rear exterior.

CAUTION	: INVISIBLE LASER RADIATION WHEN OPEN. AVOID EXPOSURE TO BEAM.
ADVARSEL	: USYNLIG LASERSTRÅLING VED ÅBNING NÅR SIKKERHEDSÅFBRYDERE ER UDE AF FUNKTION. UNDGÅ UDSÆTTELSE FOR STRÅLING.
VARO!	: AVATTAESSA JA SUOJALUKITUS OHITETTAESSA DLET ALTIINA LASERSÄTELYLLE.
VARNING	: LASERSTRÅLING NÅR DENNA DEL ÄR ÖPPNAD OCH SPÄRREN ÄR URKOPPLAD.
ADVARSEL	: USYNLIG LASERSTRÅLING NÅR DEKSEL ÅPNES UNNGÅ EKSPONERING FOR STRÅLEN.

This caution label is located inside the unit.

For the customers in Canada

CAUTION

TO PREVENT ELECTRIC SHOCK, DO NOT USE THIS POLARIZED AC PLUG WITH AN EXTENSION CORD, RECEPTACLE OR OTHER OUTLET UNLESS THE BLADES CAN BE FULLY INSERTED TO PREVENT BLADE EXPOSURE.

SECTION 1 SERVICING NOTE

SAFETY CHECK-OUT (US model only)

After correcting the original service problem, perform the following safety checks before releasing the set to the customer: Check the antenna terminals, metal trim, "metallized" knobs, screws, and all other exposed metal parts for AC leakage. Check leakage as described below.

LEAKAGE

The AC leakage from any exposed metal part to earth Ground and from all exposed metal parts to any exposed metal part having a return to chassis, must not exceed 0.5 mA (500 microamperes). Leakage current can be measured by any one of three methods.

1. A commercial leakage tester, such as the Simpson 229 or RCA WT-540A. Follow the manufacturers' instructions to use these instruments.
2. A battery-operated AC milliammeter. The Data Precision 245 digital multimeter is suitable for this job.
3. Measuring the voltage drop across a resistor by means of a VOM or battery-operated AC voltmeter. The "limit" indication is 0.75 V, so analog meters must have an accurate low-voltage scale. The Simpson 250 and Sanwa SH-63Trd are examples of a passive VOM that is suitable. Nearly all battery operated digital multimeters that have a 2V AC range are suitable. (See Fig. A)

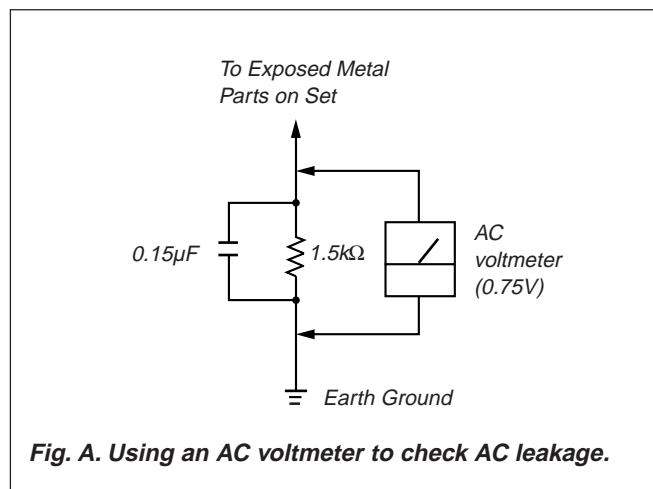

Fig. A. Using an AC voltmeter to check AC leakage.

NOTES ON HANDLING THE OPTICAL PICK-UP BLOCK OR BASE UNIT

The laser diode in the optical pick-up block may suffer electrostatic breakdown because of the potential difference generated by the charged electrostatic load, etc. on clothing and the human body.

During repair, pay attention to electrostatic breakdown and also use the procedure in the printed matter which is included in the repair parts.

The flexible board is easily damaged and should be handled with care.

NOTES ON LASER DIODE EMISSION CHECK

The laser beam on this model is concentrated so as to be focused on the disc reflective surface by the objective lens in the optical pick-up block. Therefore, when checking the laser diode emission, observe from more than 30 cm away from the objective lens.

LASER DIODE AND FOCUS SEARCH OPERATION CHECK

Carry out the "S curve check" in "CD section adjustment" and check that the S curve waveform is output repeatedly.

SAFETY-RELATED COMPONENT WARNING !!

COMPONENTS IDENTIFIED BY MARK \triangle OR DOTTED LINE WITH MARK \triangle ON THE SCHEMATIC DIAGRAMS AND IN THE PARTS LIST ARE CRITICAL TO SAFE OPERATION. REPLACE THESE COMPONENTS WITH SONY PARTS WHOSE PART NUMBERS APPEAR AS SHOWN IN THIS MANUAL OR IN SUPPLEMENTS PUBLISHED BY SONY.

ATTENTION AU COMPOSANT AYANT RAPPORT À LA SÉCURITÉ!!

LES COMPOSANTS IDENTIFIÉS PAR UNE MARQUE \triangle SUR LES DIAGRAMMES SCHÉMATIQUES ET LA LISTE DES PIÈCES SONT CRITIQUES POUR LA SÉCURITÉ DE FONCTIONNEMENT. NE REMPLACER CES COMPOSANTS QUE PAR DES PIÈCES SONY DONT LES NUMÉROS SONT DONNÉS DANS CE MANUEL OU DANS LES SUPPLÉMENTS PUBLIÉS PAR SONY.

SECTION 2 GENERAL

LOCATION OF PARTS AND CONTROLS

Front Panel

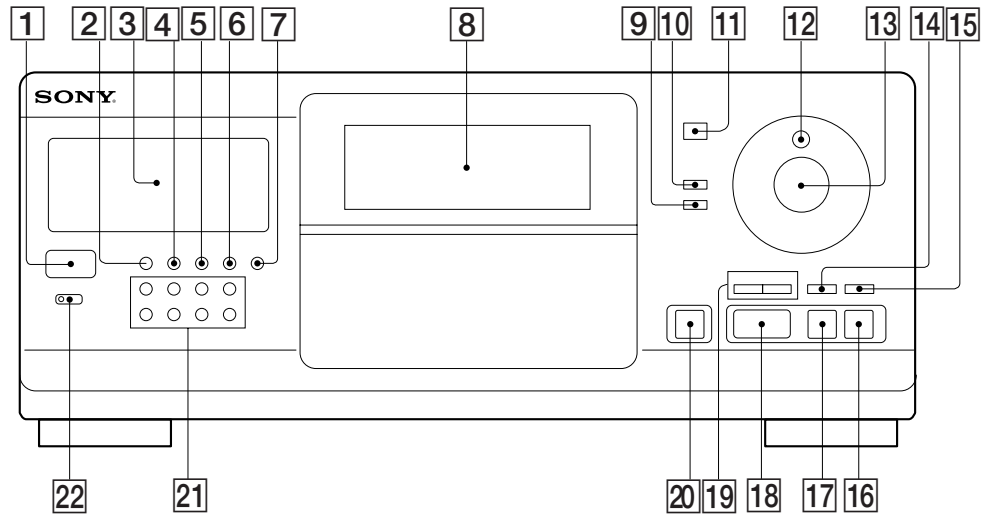

- 1** POWER button
- 2** CONTINUE button
- 3** Display window
- 4** SHUFFLE button
- 5** PROGRAM button
- 6** REPEAT button
- 7** TIME/TEXT button
- 8** Front cover
- 9** MEMO SEARCH button
- 10** INPUT button
- 11** Remote sensor

- 12** JOG dial
- 13** ENTER button
- 14** CHECK button
- 15** CLEAR button
- 16** ■ (stop) button
- 17** ■■ (pause) button
- 18** ▷ (play) button
- 19** ◀◀ AMS* ▶▶ button
- 20** OPEN button
- 21** GROUP buttons 1-8
- 22** TIMER switch

* AMS is the abbreviation for Automatic Music Sensor.

Getting Started



When to use the COMMAND MODE selector
 The COMMAND MODE selector is set to CD1 at the factory for normal use. You can control this player by connecting to a Sony CD Player with the player control function, via the CONTROL A1 jacks. When making this connection, set the COMMAND MODE selectors of each player to the appropriate position according to the connected line input jacks. For details, refer to the instructions supplied with the connected player.



When using another Sony CD player together with this player
 You can make the supplied remote effective only for this player.

- When using the player equipped with the COMMAND MODE selector:
 Set the COMMAND MODE selector of this player to CD1 and that of another player to CD2 or CD3. Then set the CD1/2/3 switch on the remote supplied for each player accordingly.
- When using the player not equipped with the COMMAND MODE selector:
 The command mode of the player without the COMMAND MODE selector is set to CD1. Set the COMMAND MODE selector of this player to CD2, and set the CD1/2/3 switch on the remote to CD2.

Setting the VOLTAGE SELECTOR (for E model)

Check that the VOLTAGE SELECTOR on the rear panel of the player is set to the local power line voltage. If not, set the selector to the correct position using a screwdriver before connecting the AC power cord to a wall outlet.

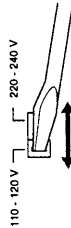

Getting Started

Inserting CDs

You can insert up to 200 discs into this player.

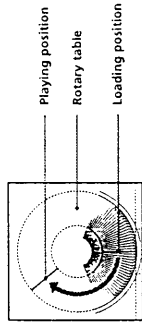
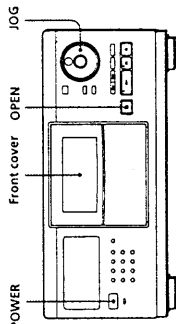

1 Press POWER to turn on the player.

2 Press OPEN.

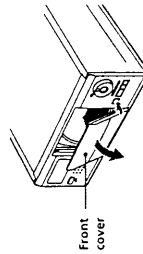

3 Turn the JOG dial until you find the disc slot where you want to insert a disc, while checking the disc number (written beside every five slots and also indicated in the display).

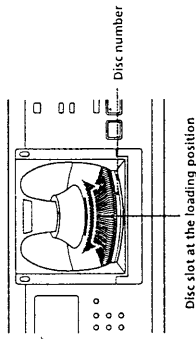

The disc number at the loading position appears in the display.* If the disc has the Disc Memo (see page 17), the Disc Memo appears instead of the disc number. As you turn the JOG dial, the disc number or the Disc Memo changes.

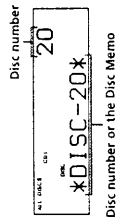

- If you have already inserted discs, the disc number at the playing position appears. When you turn the JOG dial, the displayed disc number changes to the one at the loading position.

4 Insert a disc with the label side facing right.

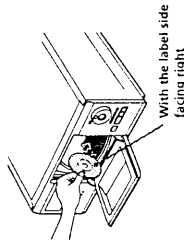
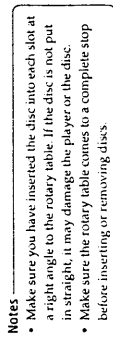

After inserting the disc, you can input the original disc titles instead of the disc numbers (see "Labeling Discs" on page 17) to locate it easily when you start playing.

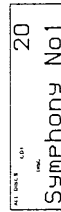

5 Repeat Steps 3 and 4 to insert more discs.

This section is extracted from instruction manual.

- Close the front cover by pressing the right edge of the cover until it clicks.

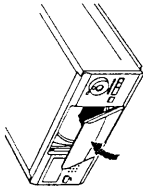

The rotary table turns and the disc slot at the loading position is set to the playing position. Always close the front cover except when you insert or remove discs.

Notes The supplied CD booklet holders help you locate a disc

You can store up to 200 CD booklets. Insert a booklet and stick the number label on the film of a pocket and the booklet so that you can locate the disc easily.

- When you insert an 8 cm (3.1 inch) CD, be sure to attach a Sony CSA-8 adapter (not supplied) to the disc. Do not insert an empty 8 cm (3.1 inch) CD adaptor (CSA-8). It may damage the player.
- Do not attach anything such as seals or sleeves to CDs. It may damage the player or the disc.
- If you drop a disc into the player and the CD won't go into the slot correctly, consult your nearest Sony dealer.
- When transporting the player, remove all discs from the player.

Removing CDs

After following Steps 1 to 3 of "Inserting CDs" on page 6, remove the discs. Then close the front cover.

Note The disc being played does not come to the loading position if you open the front cover during playback. (The disc number flashes in the display.)
If you want to remove the disc being played, press ENTER in the center of the JOG dial after opening the front cover. The disc comes to the loading position. Remove the disc after the rotary table comes to a complete stop.

Using the Display

You can check information about the disc using the display.

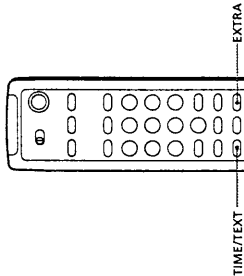
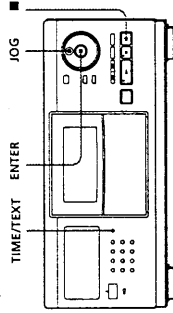

Checking the total number and playing time of the tracks

Select the disc you want to check, and press ENTER in the Continuous Play mode. As the player starts play automatically, press **■** to stop, and then TIME/TEXT. The display shows the current disc number, total number of tracks and total playing time of the disc.

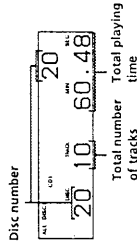

When you want to check another disc

Press DISC SKIP on the remote in the stop mode to select the disc you want to check. The total number of tracks and the total playing time of the selected disc appear for a while.

Display information while playing a disc

While playing a disc, the display shows the current disc number, track number, playing time of the track and the next disc number.

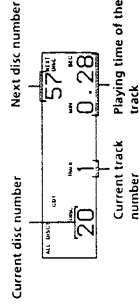

Checking the information of CD-TEXT discs

CD-TEXT discs have information, such as the disc titles or artist names, memorized in a blank space on the discs where there is no information on normal discs. The display shows the CD-TEXT information of the disc so that you can check the current disc title, track title and artist name. When you select a CD-TEXT disc, the "CD-TEXT" indication lights up in the display.

Display information before you start playing

The display shows the disc title. When you press TIME/TEXT, the artist name scrolls in the display. If you press TIME/TEXT again, the display shows the current disc number, total number of tracks and total playing time of the disc. The display shows the disc title again after a while.

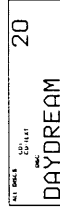

Display information while playing a disc

Each time you press TIME/TEXT, the display shows the information as shown below.

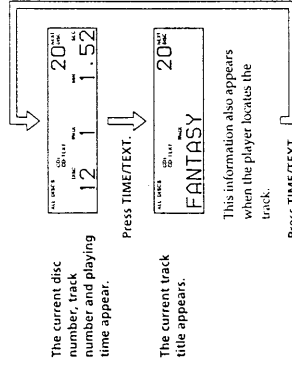

The current disc number, track number and playing time appear.

Press TIME/TEXT.

The current track title appears.

This information also appears when the player locates the track.

Press TIME/TEXT.

To play disc highlights
Some CD-TEXT discs have a feature to play only the highlights of the discs.
Press EXTRA to start playing disc highlights.
If you press EXTRA while selecting discs without this feature, "NO EXTRA" appears in the display.

Locating a Specific Disc

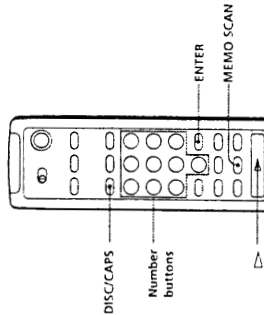
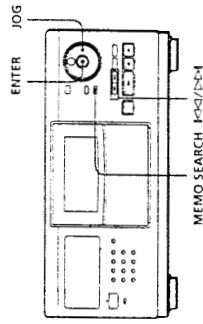

Selecting a disc on the player

Turn the JOG dial until the disc number or Disc Memo (see page 17) you want appears in the display. Press ENTER to start play.

Selecting a disc directly using the remote [1]

- 1 Press DISC/CAPS.
- 2 Press the number button of the disc.
Example: To enter number 35
Press 3, then 5.
To enter number 100
Press 1, then 0 twice.
- 3 Press ENTER to start play.

Locating a disc by scanning each Disc Memo (Memo Scan) [1]

You can locate a disc you want to play quickly by scanning the Disc Memos (see page 17) in the display and start playing.
Note that you cannot use this function in the ALL DISCS Shuffle Play mode.

- 1 Press MEMO SCAN.
"MEMO SCAN" appears in the display, and the Disc Memos scroll in the display.
- 2 Press Δ when the Disc Memo of the disc you want to play appears.
The disc is set to the playing position, and the player starts playing.
In Program Play mode, the disc will be added to the end of the program if you press ENTER instead of Δ .

Note

If "NO ENTRY" appears in the display, no disc has been labeled with the Disc Memo. Try the Memo Scan function again after labeling the discs.

Locating a disc by searching a specific Disc Memo (Memo Search)

You can search and locate a disc you want by inputting the first character used in the Disc Memo (see page 17).

- 1 Press MEMO SEARCH.
"MEMO SEARCH" appears in the display.
- 2 Press K<S>/D<S>M repeatedly to input the first character.

Input character

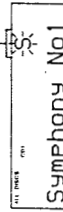

Each time you press K<S>/D<S>M, the characters appear in the following order.

A B C D E F G H I J K L M N O P Q R S T U V W X
Y Z 0 1 2 3 4 5 6 7 8 9

If "NOT FOUND" appears in the display while inputting the first character with the K<S>/D<S>M buttons, no disc has been labeled using the input character.

(Continued)

Notes

- When searching input characters, blanks and symbols before the first character in the Disc Memo are ignored.
- When searching input characters, upper and lower cases cannot be differentiated.

3 Turn the JOG dial to find the disc you want. As you turn the JOG dial, the Disc Memos starting with the input character appear in the display.

4 Press ENTER to select the disc.
In Program Play mode, the disc will be added to the end of the program.

To cancel Memo Search
Press MEMO SEARCH again.

To cancel Memo Search starting with the input character in Step 3
The input character changes to the next one when you turn the JOG dial.

Specifying the Next Disc to Play

You can specify the next disc to play while playing a disc in Continuous or 1 DISC Shuffle Play mode.

While playing a disc, turn the JOG dial until the disc number or Disc Memo (see page 17) you want appears in the display.

Next disc number

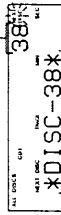

Next disc number or Disc Memo appears for a while.

After the current disc is played, the next disc you have specified starts playing.
If you want to skip to the next disc right away, press ENTER while playing the current disc.

To cancel the disc you have specified
Press CONTINUE twice.

Locating a Specific Track or a Point in a Track

You can quickly locate any track while playing a disc using the K<S>/D<S>M (AMS: Automatic Music Sensor) buttons or number buttons on the remote. You can also locate a specific point in a track while playing a disc.

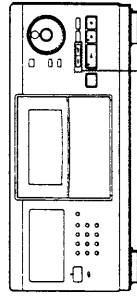

K<S>/D<S>M

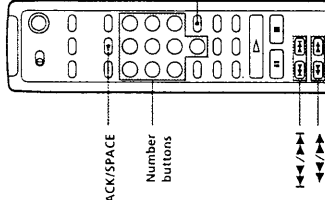

TRACK/SPACE

Number buttons

ENTER

To locate	Press
the next or succeeding tracks	D<S>M repeatedly until you find the track
the current or preceding tracks	K<S> repeatedly until you find the track
a specific track directly [1]	TRACK/SPACE, the number button of the track, and then ENTER. When you locate a track with a number over 10, press the 10's digit first, then the 1's digit.
a point in a track while monitoring the sound [1]	\blacktriangleright (forward) or \blacktriangleleft (backward) and hold down until you find the point sound
a point in a track quickly by observing the display [1]	\blacktriangleright (forward) or \blacktriangleleft (backward) and hold down until you find the point during pause. You will not hear the sound during the operation.

Note
If "OVER" appears in the display, the disc has reached the end while you were pressing **▶▶**. Press **◀◀** or **FCS** to go back.

Playing Repeatedly

You can play discs/tracks repeatedly in any play mode.

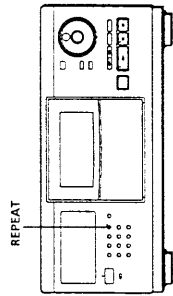

Press **REPEAT** while playing a disc.
"REPEAT" appears in the display. The player repeats the discs/tracks as follows:

When the disc is played in	The player repeats
ALL DISCS Continuous Play (page 8)	All tracks on all discs
1 DISC Continuous Play (page 8)	All tracks on the current disc
ALL DISCS Shuffle Play (page 13)	All tracks on all discs in random order
1 DISC Shuffle Play (page 13)	All tracks on the current disc in random order
Program Play (page 14)	The same program

To cancel Repeat Play
Press **REPEAT** repeatedly until "REPEAT OFF" appears in the display.

Repeating the current track

You can repeat only the current track.

While the track you want is being played, press **REPEAT** repeatedly until "REPEAT 1" appears in the display.

Playing in Random Order (Shuffle Play)

You can have the player "shuffle" the tracks and play in random order. The player shuffles all the tracks on all discs or on the disc you specified.

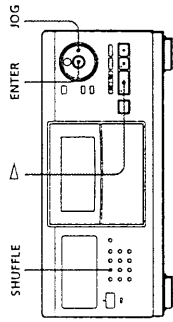

- 1 Press **SHUFFLE** to select ALL DISCS or 1 DISC Shuffle Play mode.
Each time you press **SHUFFLE**, "ALL DISCS" or "1 DISC" appears in the display.

When you select	The player plays
ALL DISCS	All tracks on all discs in random order
1 DISC	All tracks on the specific disc in random order

- 2 When you want to specify the disc for 1 DISC Shuffle Play, turn the JOG dial until the disc number or Disc Memo (see page 17) you want appears in the display.

- 3 Press **ENTER** or **▶**.
ALL DISCS or 1 DISC Shuffle Play starts.
"J" appears in the display while the player is "shuffling" the discs or the tracks.

To cancel Shuffle Play
Press **CONTINUE**.

You can start Shuffle Play while playing
Press **SHUFFLE**, and Shuffle Play starts from the current track.

You can directly select a disc for 1 DISC Shuffle Play
See "Selecting a disc directly using the remote" on page 11.

You can go to the next disc during 1 DISC Shuffle Play
Press **DISC SKIP**.

You can specify the next disc to play during 1 DISC Shuffle Play

Turn the JOG dial to specify the next disc. After all the tracks on the current disc are played in random order, the next disc starts playing. If you want to skip to the next disc right away, press **ENTER** while playing the current disc.

- You cannot specify the next disc to play during ALL DISCS Shuffle Play.
- Even if you press **▶** or turn off the player during ALL DISCS Shuffle Play, the player remembers which discs/tracks were played and which were not. Therefore, if you want to start ALL DISCS Shuffle Play again from the beginning, be sure to repeat the procedure from Step 1.

Creating Your Own Program (Program Play)

You can arrange the order of the tracks and/or discs to create three different programs and programs are stored automatically. A program can contain up to 32 "steps" — one "step" may contain a track or a whole disc.

You can make programs using the controls on the remote as well as ones on the player. However, the programming procedures are different.

Creating a program on the player

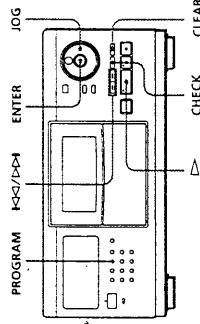

- 1 Press **PROGRAM** until the program number you want (PROGRAM 1, 2 or 3) appears in the display.
If a program is already stored in the selected program number, the last step of the program appears in the display. When you want to erase the whole program, hold down **CLEAR** until "ALL CLEAR" appears in the display (see page 16).

- 2 Turn the JOG dial until the disc number you want appears in the display.

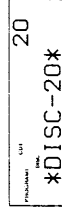

- 3 To program a whole disc, skip this step. Press **FCS/D-P1** until the track number you want appears in the display.

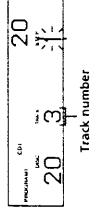

- 4 Press **ENTER** or **PROGRAM**.

The track being programmed

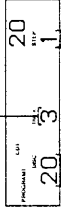

The disc being programmed
Playing order

- 5 To program other discs/tracks, do the following:

To program	Repeat Steps
Other discs	2 and 4
Other tracks on the same disc	3 and 4
Other tracks on other discs	2 to 4

- 6 Press **▶** to start Program Play.

To cancel Program Play
Press **CONTINUE**.

When you press \square , you can play the same program again.

When you press PROGRAM during Continuous or Shuffle Play
The program will be played after the current track.

The programs remain until you erase them
If you replace discs, the programmed disc and track numbers remain. So, the player plays only the existing disc and track numbers. However, the disc and track numbers that are not found in the player or on the disc are deleted from the program, and the rest of the program is played in the programmed order.

What You Can Do With the Custom Files

The player can store three types of information called "Custom Files" for each disc. Once you have stored Custom Files for a disc, the player automatically recalls what you have stored whenever you select the disc. Note that Custom Files will be erased if you do not use the player for about one month.

You can store this information:

When you use	You can
Disc Memo (page 17)	Label discs using up to 13 characters
Delete Bank (page 19)	Delete unwanted tracks and store only the tracks you want
Group File (page 20)	Group discs up to eight groups to locate them easily

Where are Custom Files stored?

Custom Files are stored not on the disc, but in the player's memory. It means you cannot use Custom Files when you play the disc on other players.

If you replace discs you have filed in the Custom Files

The Custom File information you have stored remains, since each Custom File information is assigned to each slot. Erase all Custom Files (Disc Memo, Delete Bank and Group File) of the old disc, and then file the new disc information in the Custom Files.

Erasing all Custom Files of all discs

Turn off the player. While holding down CLEAR, press POWER to turn on the player. "ALL ERASE" appears in the display, and all Custom Files will be erased.

Labeling Discs (Disc Memo)

You can label discs using up to 13 characters and have the player display the Disc Memo each time you select the disc. The Disc Memo can be anything you like, such as a title, musician's name, category or date of purchase.

When you select a CD-TEXT disc

The disc title is stored as the Disc Memo automatically. If the disc title has more than 13 characters, the first 13 characters of the disc title are stored (see page 10). When you replace a disc with a CD-TEXT disc, the disc title of the CD-TEXT disc is also stored automatically. Note that you cannot change the Disc Memo of the CD-TEXT disc.

You can label discs while the front cover is open

Labeling discs on the player

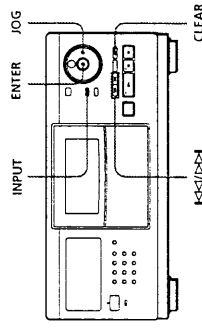

- 1 Turn the JOG dial until the disc number to which you want to assign a Disc Memo appears in the display. When you label a disc with the front cover closed, the disc number of the disc at the playing position appears. When you label a disc with the front cover open, the disc number at the loading position appears.
- 2 Press INPUT.
- 3 Turn the JOG dial until "DISC MEMO" appears in the display, and then press ENTER. The flashing cursor (\blacktriangleleft) appears.

(Continued)

- 4 Turn the JOG dial until the character you want appears in the display.
The cursor disappears and the first space for the Disc Memo flashes.
As you turn the JOG dial clockwise, the characters appear in the following order. Turn the JOG dial counterclockwise to go back to the previous character.

(space) A B C D E F G H I J K L M N O P Q R S T U
V W X Y Z a b c d e f g h i j k l m n o p q r s t u v
x y z 0 1 2 3 4 5 6 7 8 9 ! " # \$ % & ' () * + , - . / : ; <
= > ? [\] ^ _ ` { | } ~



- 5 Press ENTER to select the character.
The selected character lights up, and the flashing cursor appears to indicate the next space to be input.

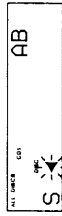

If you have made a mistake Press CLEAR and begin again by inputting the correct characters.

- 6 Repeat Steps 4 and 5 to input more characters.
7 Press INPUT to store the Disc Memo.
The Disc Memo lights up in the display.

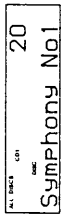

Repeat Steps 1 to 7 to assign Disc Memos to other discs.

Labeling discs using the remote

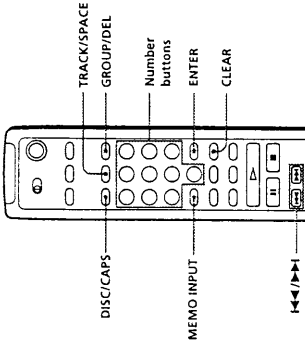

- 1 Press DISC/CAPS.
2 Press the number button of the disc you want to assign a Disc Memo, and then ENTER.
3 Press MEMO INPUT.
The flashing cursor (◀) appears.

- 4 Press DISC/CAPS to find the letter type you want.
Each time you press the button, the letter type changes cyclically among capital letters (AB), small letters (ab) and numbers (12). The selected letter type appears in the upper right corner of the display.

- 5 Press the number button corresponding to the character you want (indicated beside each number button).
The cursor disappears and the first space for the Disc Memo flashes.
Each time you press the button, the character changes cyclically among the ones indicated beside the button.

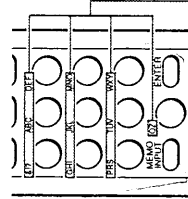

Characters assigned to each number button

Example: To select the letter E

Press the number button 3 twice.

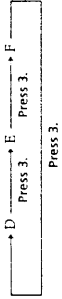

To insert a space, press TRACK/SPACE once.
To input a number, press DISC/CAPS twice in Step 4, then press the number button you want.
To input symbols, press the number button 1 repeatedly until the symbol you want appears in the display.

- 6 Press ENTER to select the character.
The selected character lights up, and the flashing cursor appears to indicate the next space to be input.
You can also go to the next space by pressing other number buttons.

- 7 Repeat Steps 4 through 6 to input more characters.
8 Press MEMO INPUT to store the Disc Memo.
The Disc Memo lights up in the display.

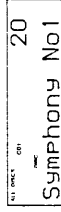

Repeat Steps 1 through 8 to assign Disc Memos to other discs.

If you have made a mistake while inputting the character

- To correct the character which has been input
1 Press DISC/CAPS until the cursor moves next to the incorrect character.

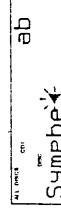

- 2 Press GROUP/DEL to delete the incorrect character.

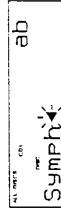

- 3 Input the correct character.

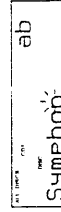

- To correct the character currently being input
1 Press GROUP/DEL to delete the incorrect character.
2 Input the correct character.

To insert a character between the input characters
Press LEFT or RIGHT until the cursor moves next to the point you want to insert, and enter the character.

Erasing the Disc Memo

- 1 Follow Steps 1 through 3 in "Labeling discs on the player" on page 17 or "Labeling discs using the remote" on page 18 to select the Disc Memo you want to erase.
2 Press CLEAR.
The Disc Memo disappears.
3 Press INPUT.

Storing Specific Tracks (Delete Bank)

You can delete unwanted tracks and store only the tracks you want. When you select the disc containing a Delete Bank, you can play only the remaining tracks.

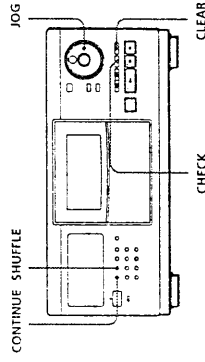

- 1 Press CONTINUE or SHUFFLE before you start playing.
2 Turn the JOG dial to select the disc.
3 Press CHECK repeatedly until the track you want to delete appears in the display.

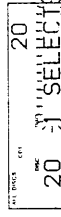

(Continued)

- 4 Press CLEAR. "DELETE FILE" appears, and "DELETE" flashes in the display.

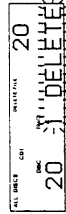

If you want to recover the track, press CLEAR again.

- 5 Repeat Steps 3 and 4 to delete more tracks.

You can recover all the tracks you have deleted
Hold down CLEAR until "ALL SELECT" appears in the display.

Note
The deleted tracks are skipped even in the Shuffle or Program Play mode (when the whole disc containing a Delete Bank is programmed as one step).

Grouping Discs (Group File)

You might find that too many discs make it hard to find the disc you want. This player has a feature that lets you classify discs into eight groups. One disc can be put into only one group. Once you classify discs, you can enjoy Continuous, Shuffle or Repeat Play only within a certain group (Group Play).

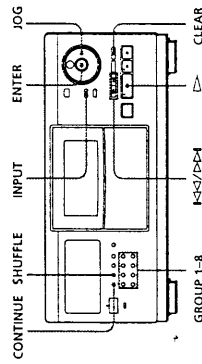

Putting discs into groups

- 1 Press CONTINUE or SHUFFLE before you start playing.
- 2 Turn the JOG dial to select the disc which you want to put into a group.
- 3 Press INPUT.

- 4 Turn the JOG dial until "GROUP FILE" appears in the display, and then press ENTER. If the disc has not been put into any group, "NOT FILED" appears in the display.

- 5 Turn the JOG dial until the group number you want (e.g., GROUP 1) appears in the display.

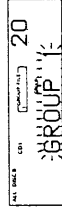

- 6 Press ENTER or INPUT to select the group.

Labeling groups (Group Memo)

You can change the preset group number to anything you like, such as a category, using up to 13 characters. Note that you cannot store the Group Memo if you have not put any disc into the group.

- 1 Press one of the GROUP 1-8 buttons to which you want to assign a Group Memo.
- 2 Press INPUT.
- 3 Turn the JOG dial until "GROUP MEMO" appears in the display, and then press ENTER. The flashing cursor (◀) appears.

- 4 Turn the JOG dial until the character you want appears in the display. The cursor disappears and the first space for the Group Memo flashes. As you turn the JOG dial clockwise, the characters appear in the following order. Turn the JOG dial counterclockwise to go back to the previous character.

```
(space) A B C D E F G H I J K L M N O P Q R S T U
V W X Y Z a b c d e f g h i j k l m n o p q r s t u v
x y z 0 1 2 3 4 5 6 7 8 9 1 # $ % & ' ( ) * + , - . / : ; <
= > ? @ [ \ ] ^ _ ` { | } ~
```

- 5 Press ENTER to select the character. The selected character lights up, and the flashing cursor appears to indicate the next space to be input.

If you have made a mistake Press CLEAR and begin again by inputting the correct characters.

You can start Group Play using the remote
Before you start playing, press GROUP/DEL, the number button of the group you want to play, then ENTER.

Note
If "NO ENTRY" appears in the display, no disc has been put into the selected group.

Deleting discs from a group

- To delete a disc from a group
 - 1 Follow Steps 1 through 4 in "Putting discs into groups" on page 20 to select the disc.
 - 2 Press CLEAR.
 - 3 "NOT FILED" appears in the display.
- To delete all discs from a group at once While holding down one of the GROUP 1-8 buttons you want to clear, press CLEAR.

- 6 Repeat Steps 4 and 5 to input more characters. See also "Labeling discs on the player" on page 17 for details.

- 7 Press INPUT to store the Group Memo.

Erasing the Group Memo

- 1 Follow Steps 1 to 3 in "Labeling groups" to select the Group Memo you want to erase.
- 2 Press CLEAR. The Group Memo disappears.
- 3 Press INPUT.

Playing discs in a group (Group Play)

You can enjoy Continuous or Shuffle Play within a group.

- 1 Press CONTINUE or SHUFFLE to select the play mode you want before you start playing.

When you select	The player plays
ALL DISCS Continuous Play	All tracks on all discs in the group consecutively
1 DISC Continuous Play	All tracks on the specified disc in the group consecutively
ALL DISCS Shuffle Play	All tracks on all discs in the group in random order
1 DISC Shuffle Play	All tracks on the specified disc in the group in random order

- 2 Press one of the GROUP 1-8 buttons to select the group and press ▶. Group Play starts from the disc which is the most upward number and located closest to the playing position. If the disc at the playing position is put into the selected group, the play starts from that disc.

You can specify the first disc to play when starting Group Play
After selecting the group, turn the JOG dial to select the disc, then press ENTER.

SECTION 3 DISASSEMBLY

Note : Follow the disassembly procedure in the numerical order given.

3-1. FRONT PANEL ASSEMBLY

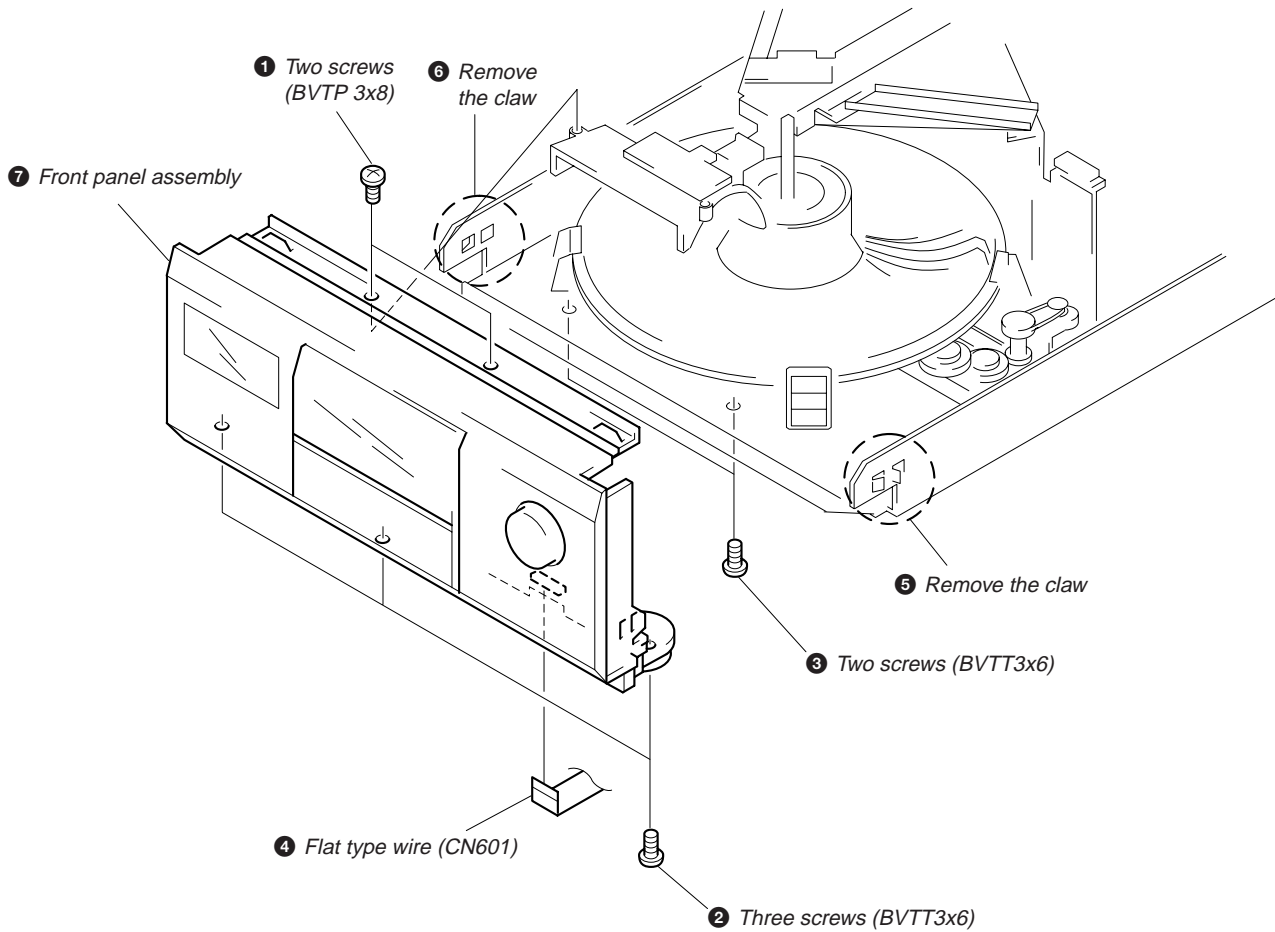

3-2. BACK PANEL ASSEMBLY

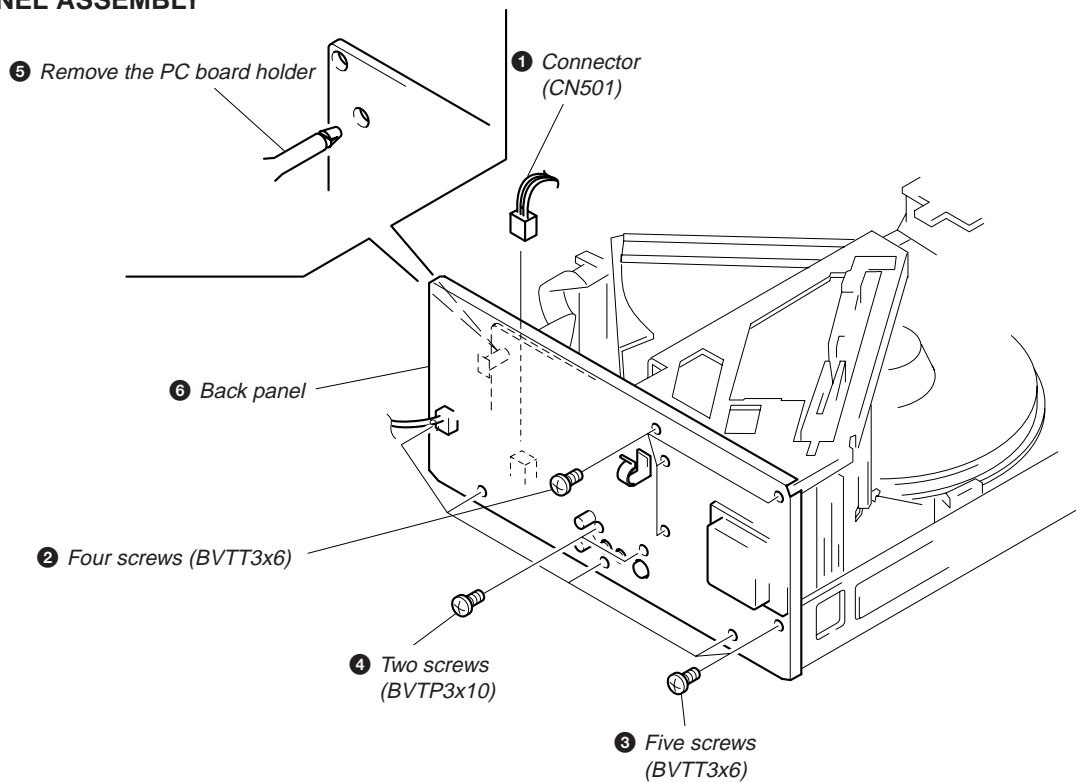

3-3. TABLE ASSEMBLY

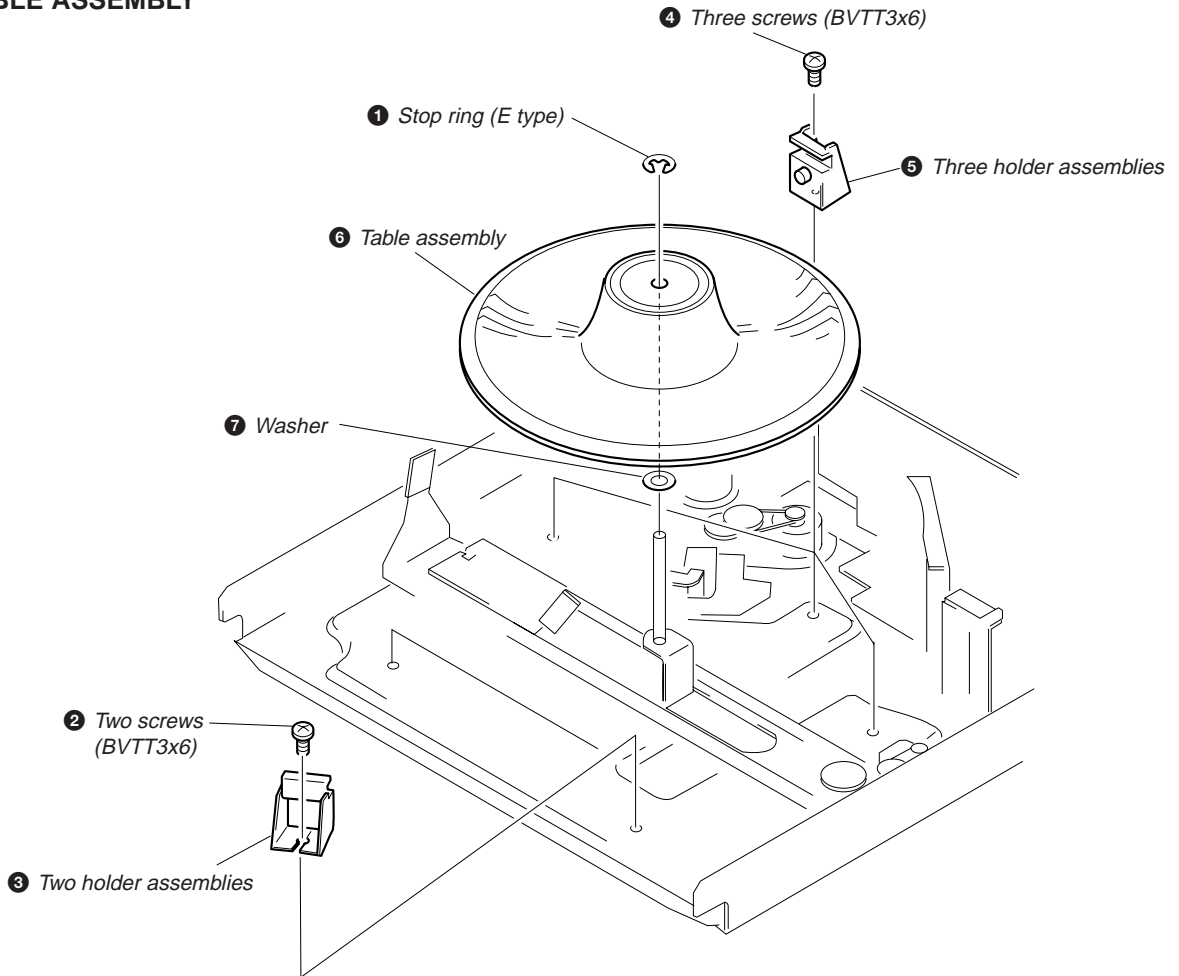

3-4. MECHANISM DECK

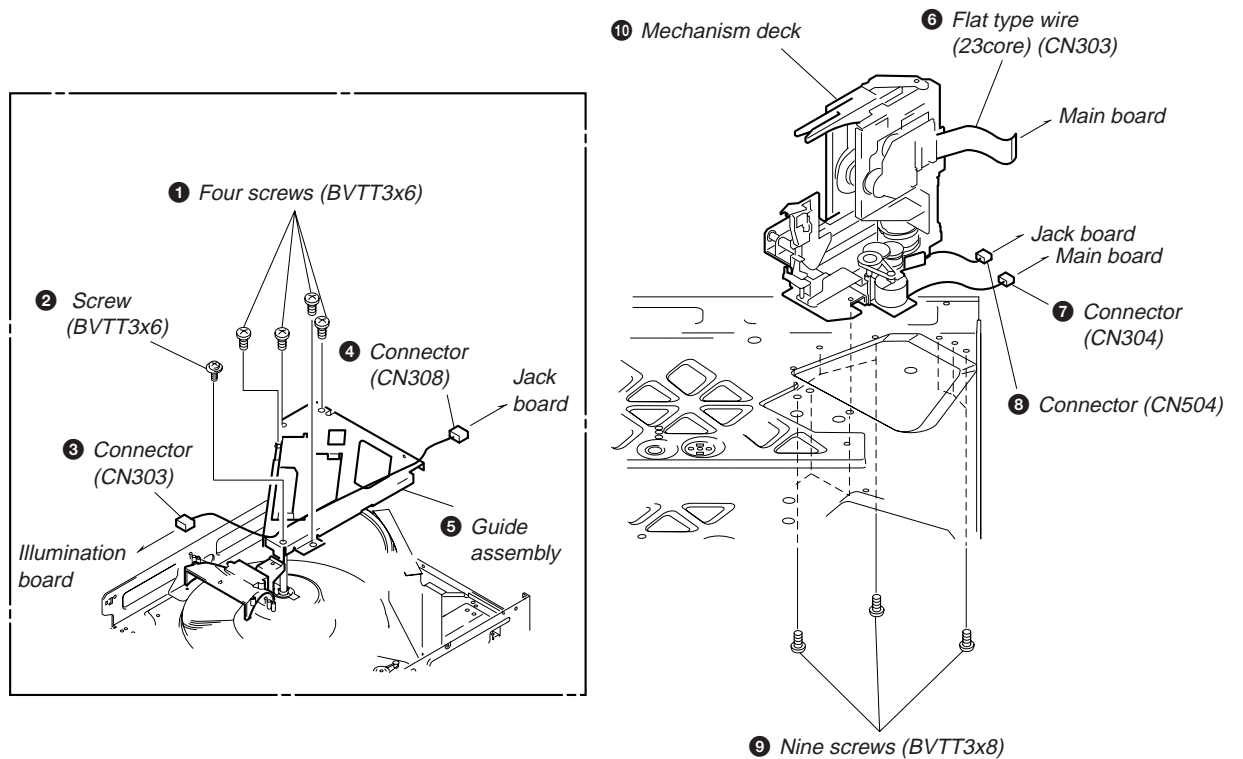

3-5. BASE UNIT

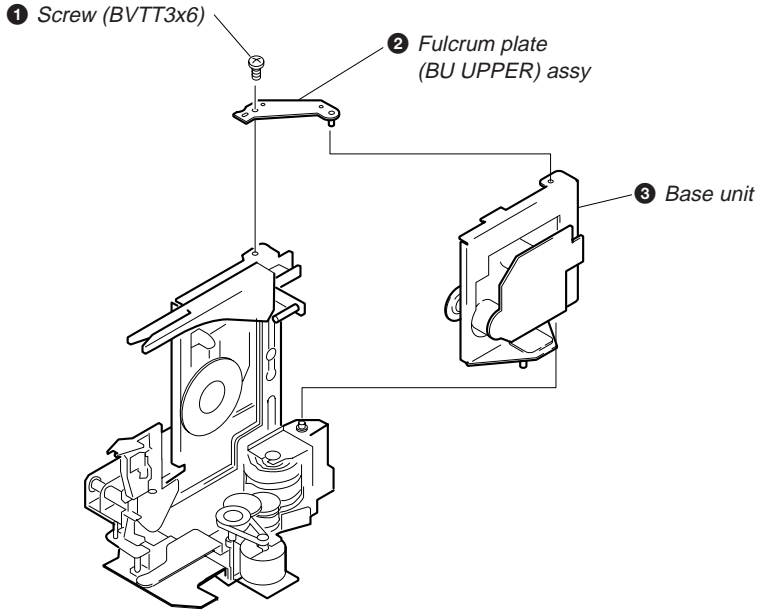

SECTION 4 TEST MODE

4-1. Display Check Mode

With the power turned off (standby state), press the POWER button while pressing the **||** (pause) button.

All FL segments and grids light up together with the **▷** (play), **||** (pause), and standby LEDs.

At the same time, the GROUP LEDs are scanned one by one.

Note: To exit this mode, press the POWER button.

4-2. ADJ Mode

1. Turn ON the power of the unit, set disc to disc table, and perform chucking.
2. Disconnect the power supply plug from the outlet.
3. To set ADJ mode, connect the test point (TP301: ADJ) of the MAIN board to Ground, and connect the power supply plug to the outlet.

The power will turn on automatically, and the first track will be played. In this mode, table rotation and loading operations are not performed because it is taken that the disc has already been chucked.

Note: The same operations are also performed in the following when the test point (TP301: ADJ) is connected to Ground after turning on the power.

- Direct search (movement of sledding motor) is not performed during accessing
- Ignored even when GFS becomes L
- Ignored even when the Q data cannot be read
- Focus gain does not decrease
- Spindle gain does not decrease
- Servo related settings can be set manually and checked (Refer to ADJ Mode Special Functions Table)

ADJ Mode Special Functions Table

(The buttons shown with () function by using the supplied remote commander only)

Button	Function
CONTINUE	Servo average display Displays VC, FE, RF, TE and traverse in hexadecimal numbers
SHUFFLE	Focus bias display Each time this is pressed, the focus bias is switched between 1 and 2 (1) Bias actually set Optimum bias Minimum jitter (2) U:Upper aliasing bias L:Lower aliasing bias
PROGRAM	Auto gain display Displays focus, tracking, sledding in hexadecimal numbers
GROUP 1 (1)	Increases the focus bias in 8 steps.
GROUP 2 (2)	Sets the focus bias in the middle of aliasing.
GROUP 3 (3)	Turns off the tracking and sledding servo
GROUP 4 (4)	Returns the auto gain to the initial value (30)
GROUP 5 (5)	Turns off the focus servo
GROUP 6 (6)	Decreases the focus bias in 8 steps.
GROUP 7 (7)	Re-adjusts the focus bias
GROUP 8 (8)	Turns on the tracking and sledding servo
(9)	Switches the focus servo gain between normal and down FG. norm: normal, FG. down: down
(10/0)	Sets the focus bias to 0 (no bias) Next, displays the jitter measured at the focus bias set
CHECK	S-curve observation mode
CLEAR	Automatic eccentric measurement The results of measurement is displayed in μm directly.

4-3. Key and Display Check Mode

To set this mode, connect the test point (TP302: AFADJ) on the MAIN board to Ground, and connect the power supply plug to the outlet.

- All FL segments and grids will light up. (All lit check)
When a button is pressed, the types of buttons pressed until then will be displayed on the left side and the number of the buttons will be displayed on the right side. However, these will not be displayed for the following special buttons.
- **■**(stop) button: FL segment check
(Refer to FL Tube Check Patterns)
- **||**(pause) button: FL grid check (Refer to FL Tube Check Patterns)
The pause LED also lights up simultaneously.
- **▷**(play) button: All FL segment and grid will light up.
The play LED also lights up simultaneously.

FL Tube Check Patterns

Segment check

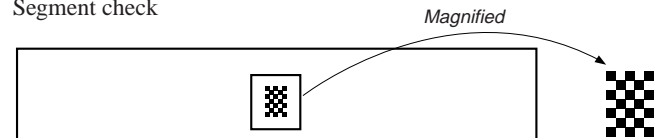

Grid check



- When the jog dial is rotated to the right, the GROUP LEDs light up in the order of 1→2..8→1.
- When the jog dial is rotated to the left, the GROUP LEDs light up in the order of 8→7..1→8.
- The standby LED lights up when the door switch is shut.

- Abbreviation
FL: Fluorescent Indicator Tube

[MAIN BOARD] — Component Side —

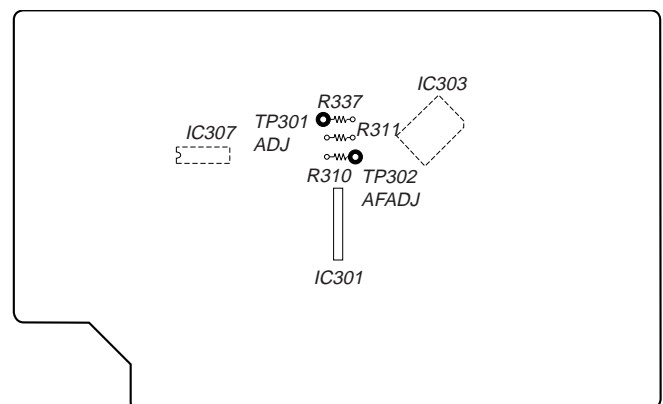

SECTION 5 ADJUSTMENTS

5-1. MECHANICAL ADJUSTMENT

Perform the following steps before carrying out adjustments.

1. Turn ON the power of the unit, set disc to disc table No. 92, and perform chucking.
2. Turn OFF the power.
3. Remove the case.
4. While pressing the STOP button, turn ON the POWER button. The test mode is set.
5. The POWER button LED starts blinking. (Test mode)

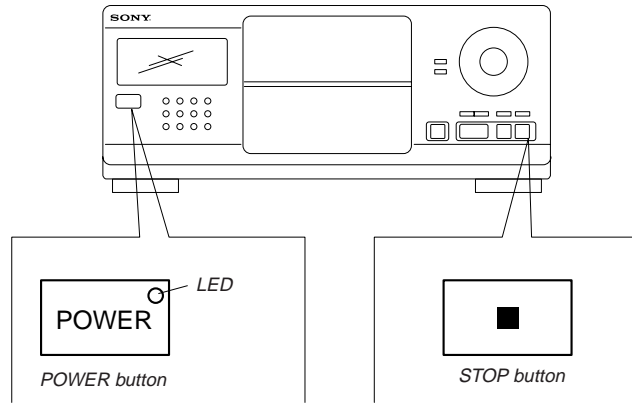

NOTE 1: The cam will start rotating when the GROUP 1 or GROUP 5 button is pressed continuously in the test mode.

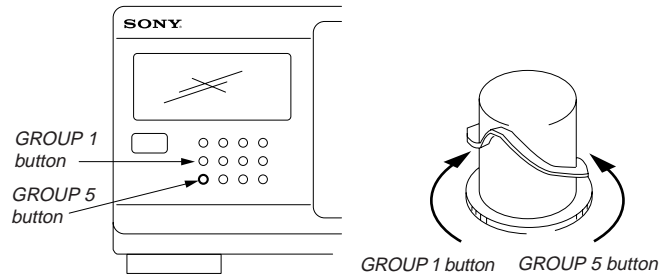

NOTE 2: If the power cannot be supplied, the cam can be rotated by rotating the pulley with your finger.

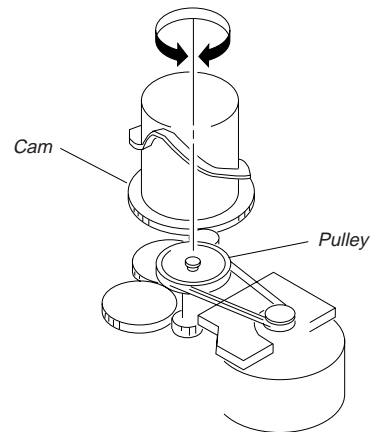

SENSOR ALIGNMENT

If the disc table swings to the left and right just before the disc is chucked, perform the following adjustment.

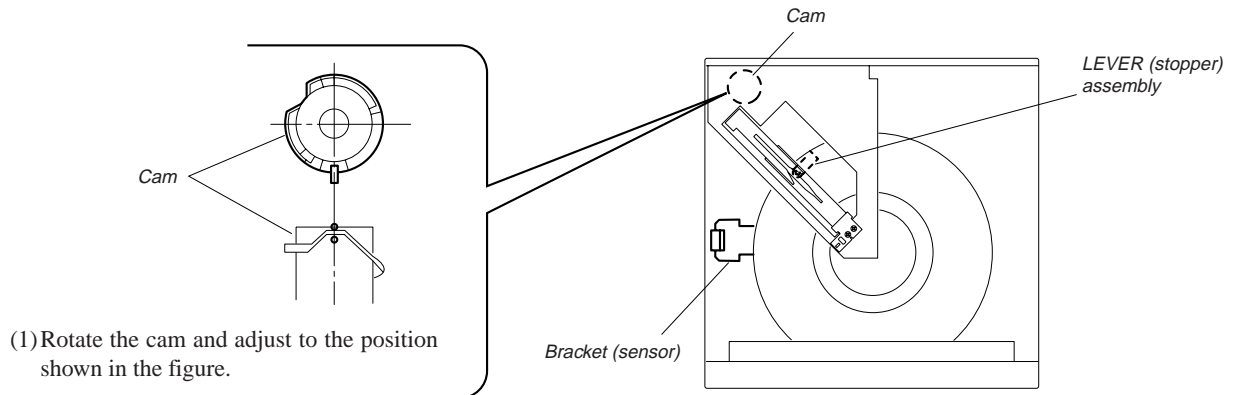

(2) Check that the lever (stopper) assembly secures the disc table as shown in the figure.

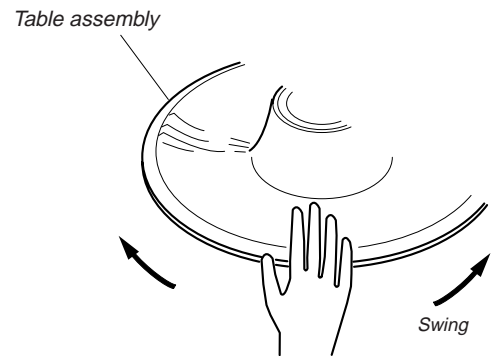
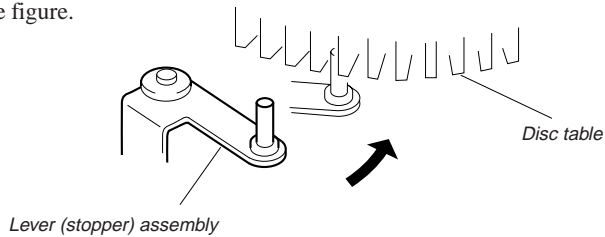

(4) Moving the disc table right and left with a hand after the screw is fixed, the table will move by the play of a disc table. If the LEDs light up alternately, the adjustment will be performed correctly.

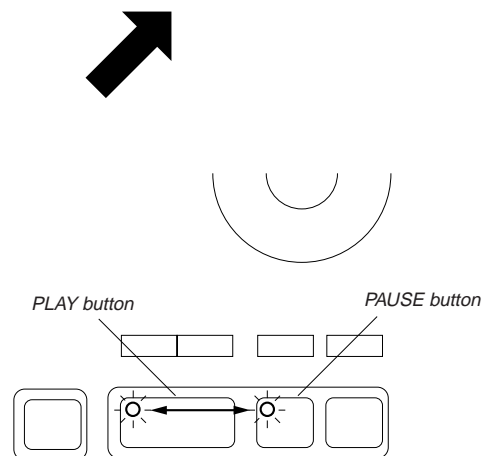
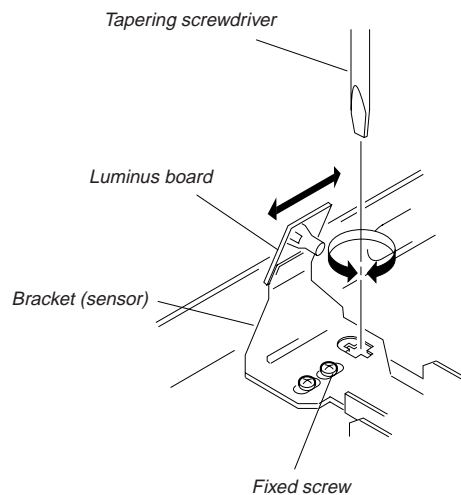

(3) Loosen the fixed screw by 60° to 90°, and use a tapering screwdriver to adjust the screw as shown in the figure.

Move the bracket (sensor) with the tapering screwdriver little by little, and fix the fixed screw at where the play button's LED (green) is switched to the pause button's LED (orange) (or its reverse).

GUIDE (DISC T) ALIGNMENT

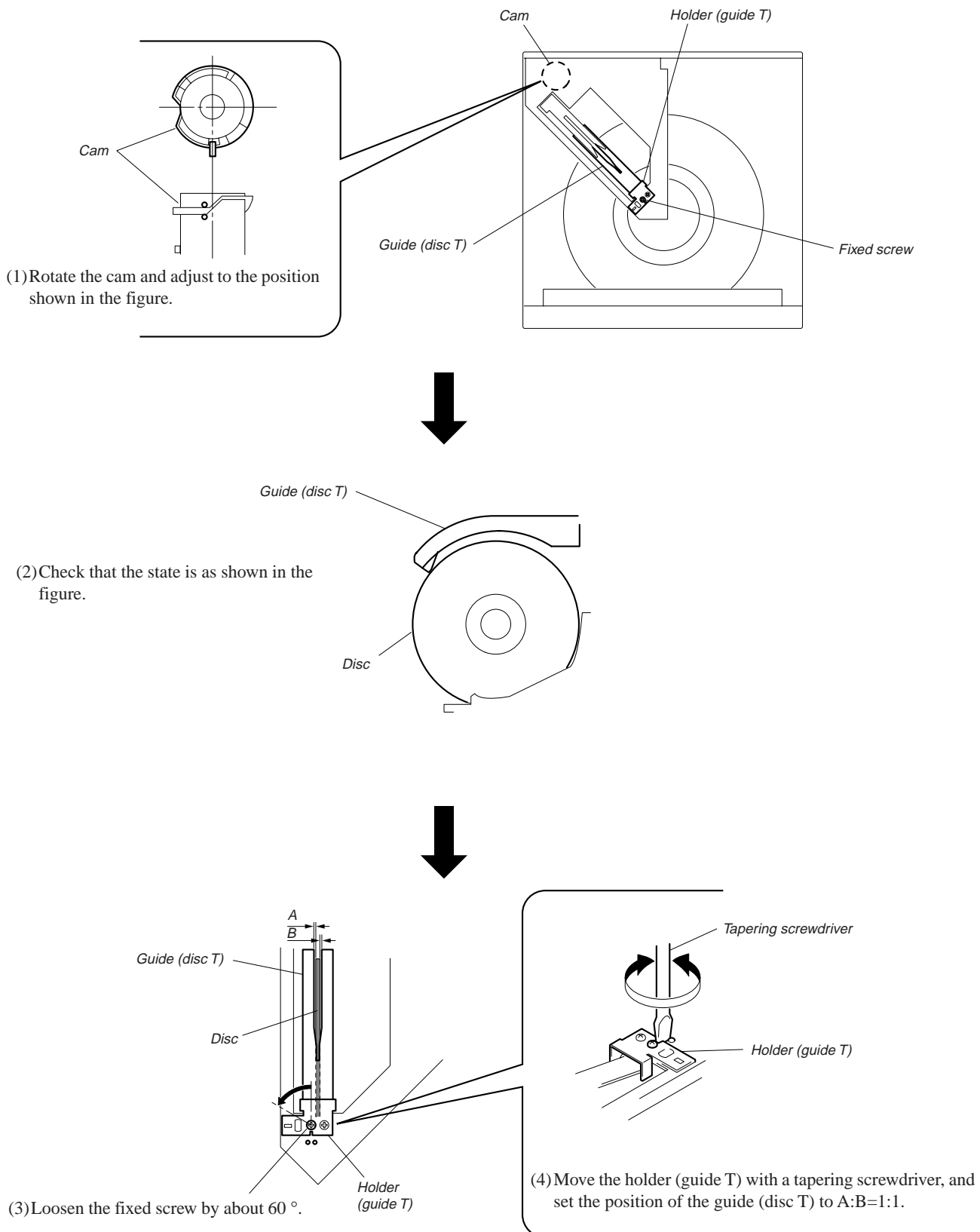

HOLDER (DISC A) ALIGNMENT

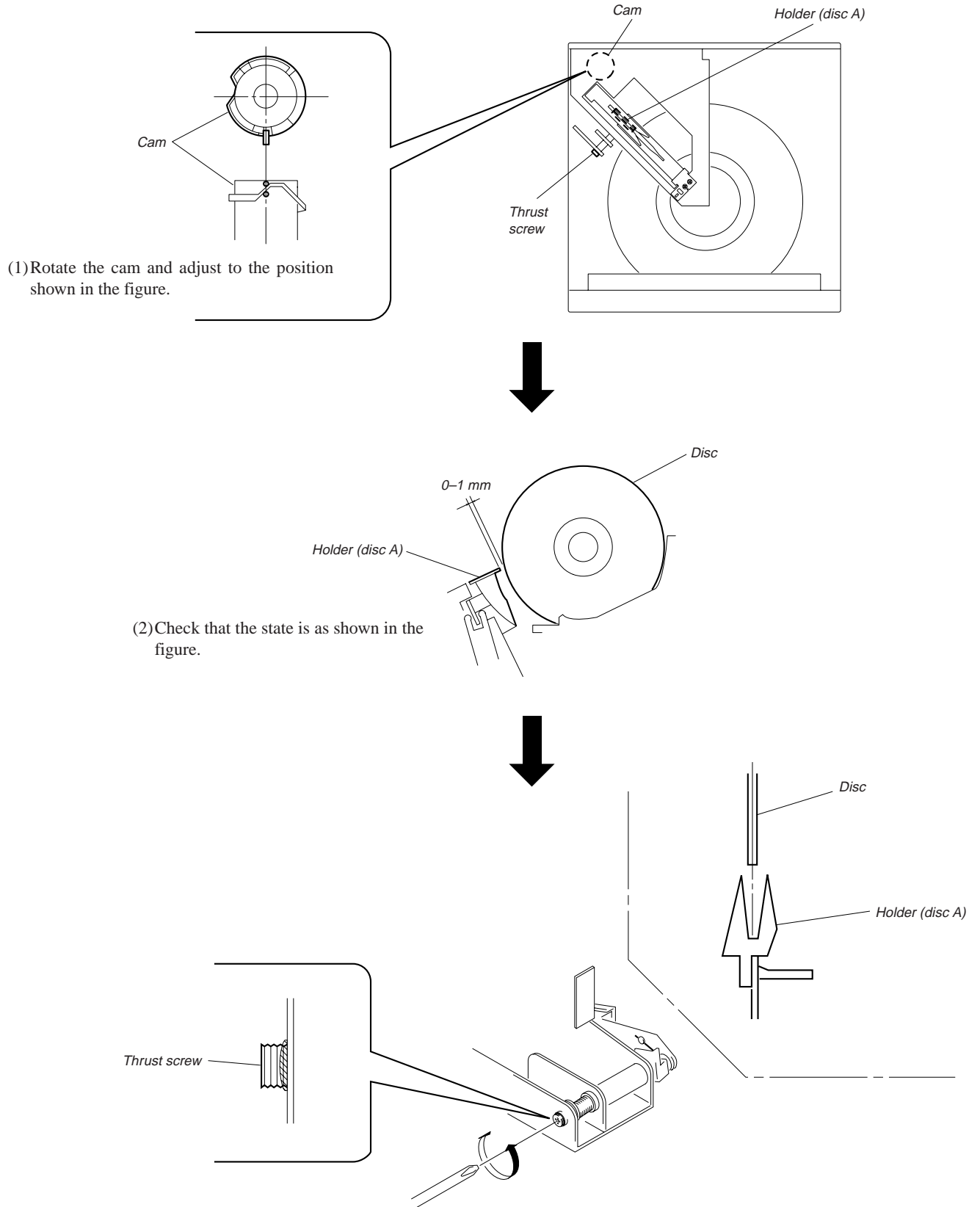

PULLY AND DISC CENTER HOLE ALIGNMENT

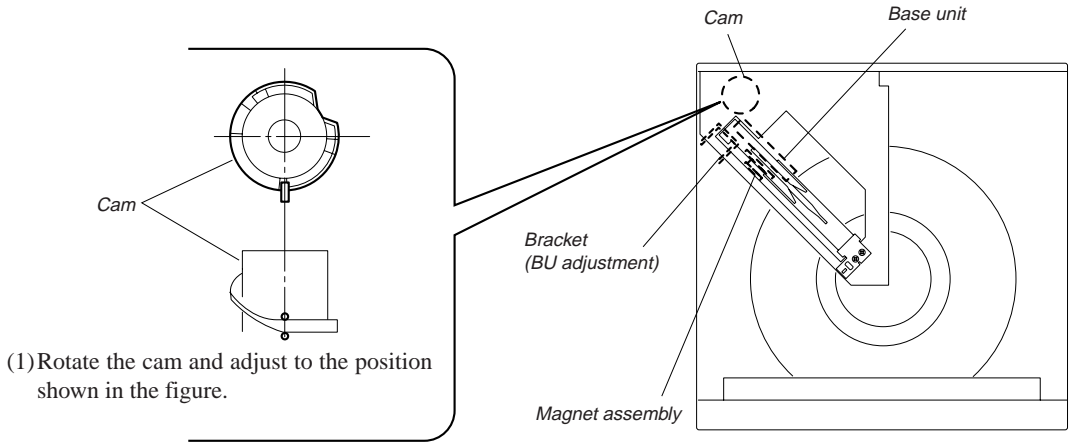

(2) Check that the state is as shown in the figure.

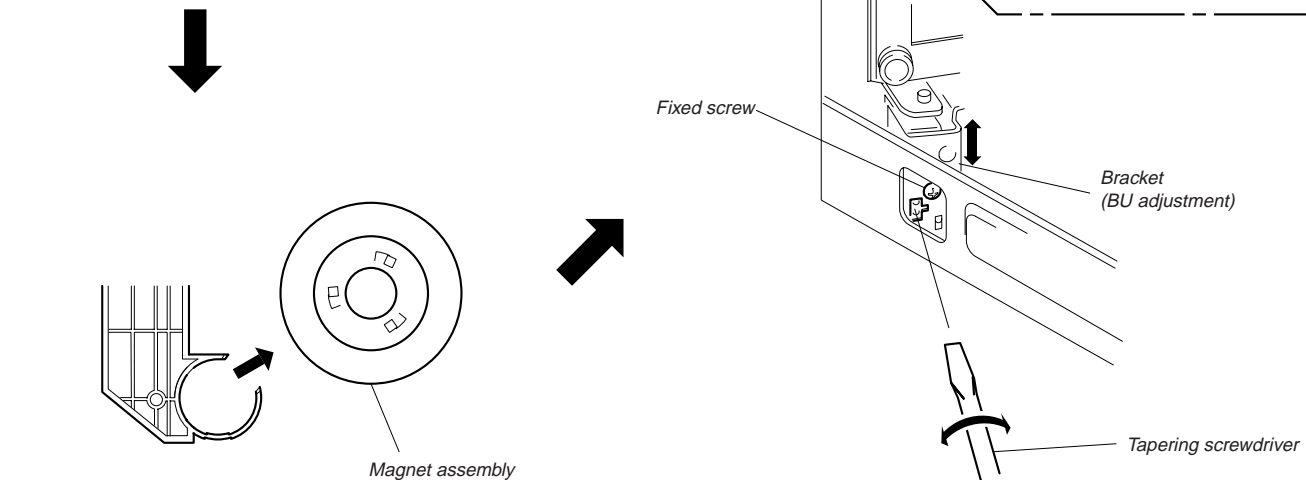
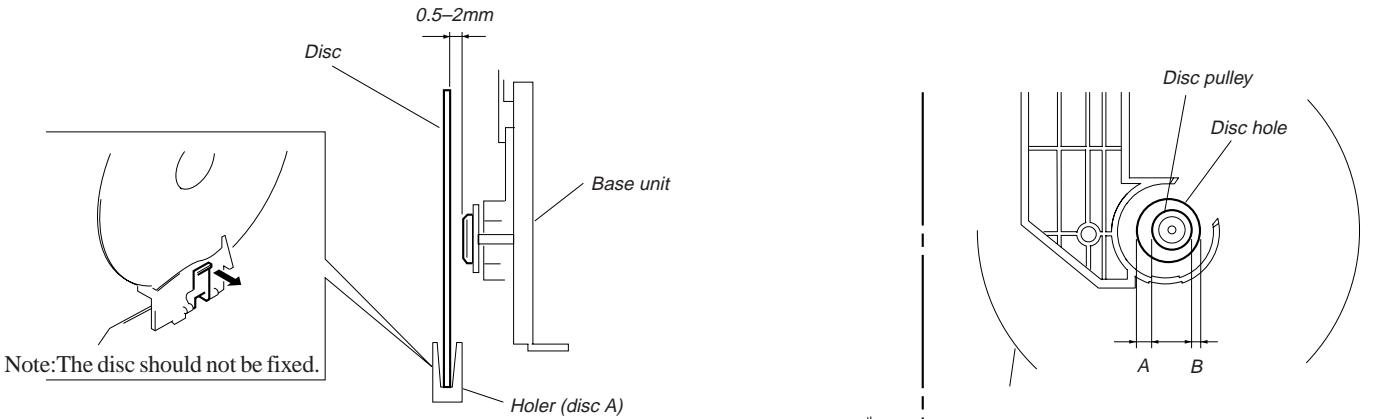

(3) Remove the Magnet assembly.

Loosen the fixed screw by 60° to 90° , and move and adjust the bracket (BU adjustment) up and down using a tapering screwdriver so that the positions of the disc hole and disc pulley become $A=B$ or between $A:B=2:1$ and $1:2$.

MAGNET ASSY ALIGNMENT

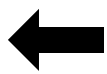
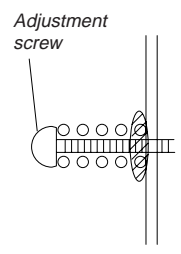
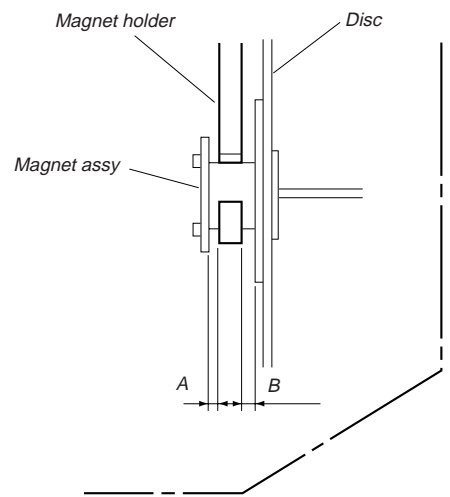
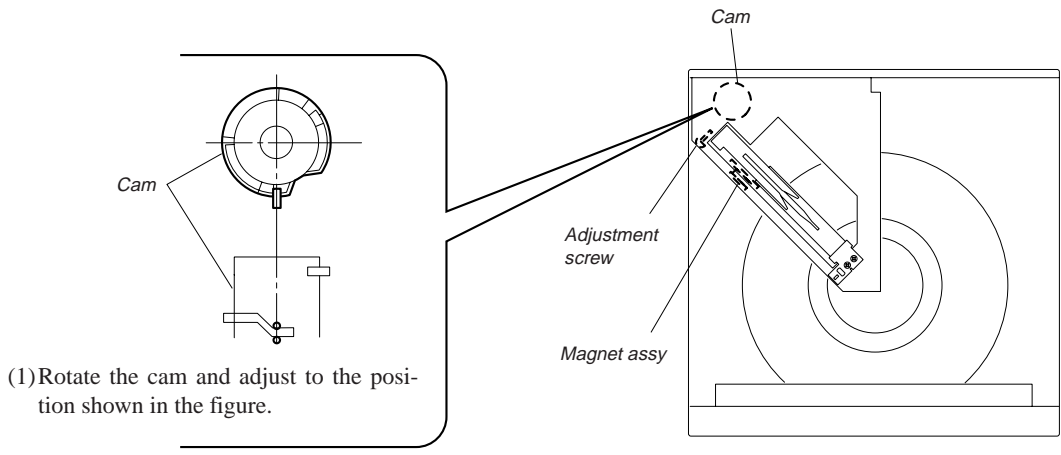

(3) Apply screw-lock to the  part after adjusting.

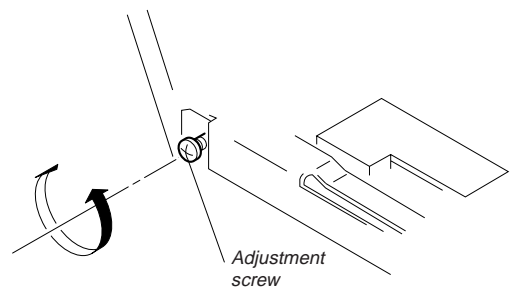

(2) Rotate the adjustment screw until $A=B$ or between $A:B=2:1$ and $1:2$

5-2. ELECTRICAL BLOCK CHECKING

Note:

1. CD Block is basically designed to operate without adjustment. Therefore, check each item in order given.
2. Use YEDS-18 disc (3-702-101-01) unless otherwise indicated.
3. Use an oscilloscope with more than $10M\Omega$ impedance.
4. Clean the object lens by an applicator with neutral detergent when the signal level is low than specified value with the following checks.

S-Curve Check

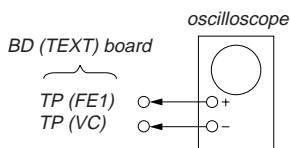

Procedure :

1. Connect oscilloscope to test point TP (FE1) on BD (TEXT) board.
2. Connect test point TP301 (ADJ) on MAIN board to ground with lead wire.
3. Turn Power switch on to set the ADJ mode.
4. Put disc (YEDS-18) in and playback. Press the CHECK button.
5. Check the oscilloscope waveform (S-curve) is symmetrical between A and B. And confirm peak to peak level within 3 ± 1 Vp-p.

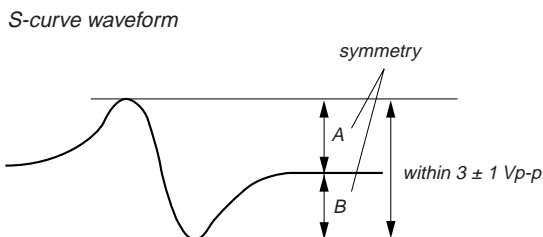

6. After check, remove the lead wire connected in step 2.

Note : • Try to measure several times to make sure than the ratio of A : B or B : A is more than 10 : 7.

- Take sweep time as long as possible and light up the brightness to obtain best waveform.

RF Level Check

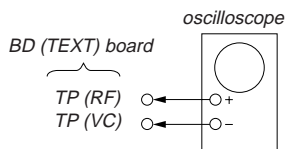

Procedure :

1. Connect oscilloscope to test point TP (RF) on BD (TEXT) board.
2. Turn Power switch on.
3. Put disc (YEDS-18) in to play the number five track.
4. Confirm that oscilloscope waveform is clear and check RF signal level is correct or not.

Note: A clear RF signal waveform means that the shape “∩” can be clearly distinguished at the center of the waveform.

RF signal waveform

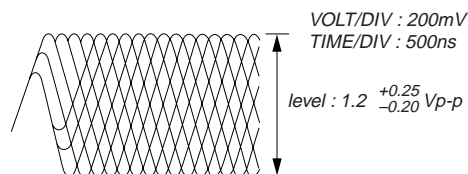

E-F Balance Check

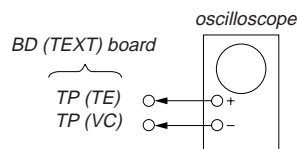

Procedure :

1. Connect oscilloscope to test point TP (TE) on BD (TEXT) board.
2. Connect the test point TP301 (ADJ) on MAIN board to the ground with a lead wire.
3. Turn the Power switch on to set the ADJ mode.
4. Put disc (YEDS-18) in to play the number five track.
5. Press the “GROUP 3” button. (The tracking servo and the sledding servo are turned OFF.)
6. Check the level B of the oscilloscope's waveform and the A (DC voltage) of the center of the Traverse waveform. Confirm the following :
 $A/B \times 100 = \text{less than } \pm 22\%$

Traverse waveform

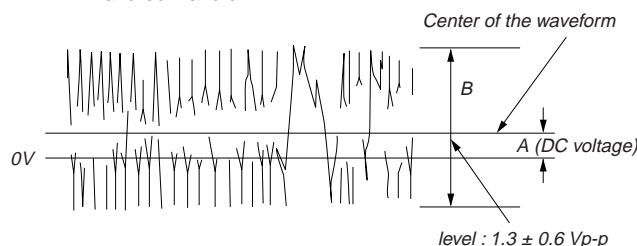

7. Press the “GROUP 8” button. (The tracking servo and sledding servo are turned ON.) Confirm the C (DC voltage) is almost equal to the A (DC voltage) is step 6.

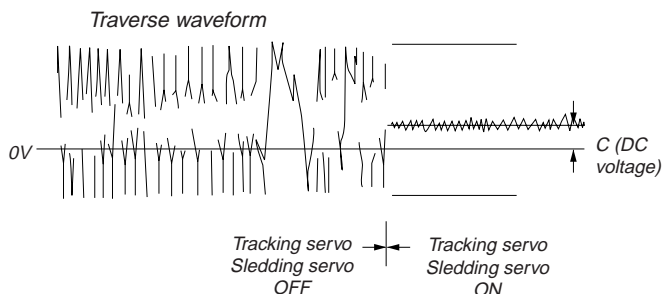

8. Disconnect the lead wire of TP301 (ADJ) connected in step 1.

RF PLL Free-run Frequency Check

Procedure :

1. Connect frequency counter to test point TP (PLCK) with lead wire.

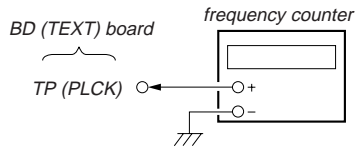

2. Turn Power switch on.
3. Put the disc (YEDS-18) in to play the number five track.
Confirm that reading on frequency counter is 4.3218MHz.

Adjustment Location :

[BD (TEXT) BOARD] — Side B —

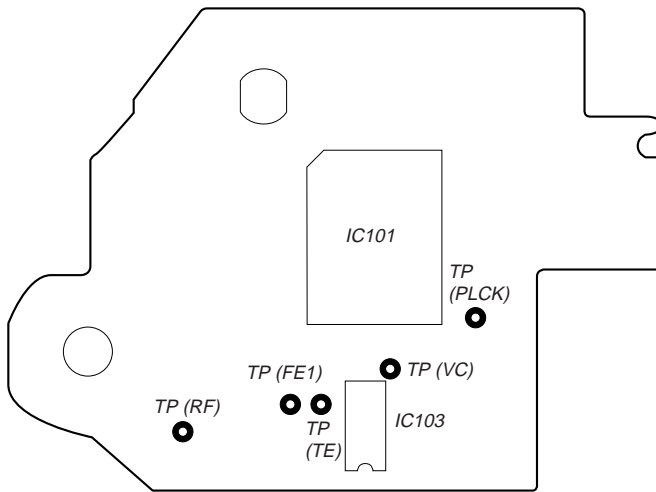

[MAIN BOARD] — Component Side —

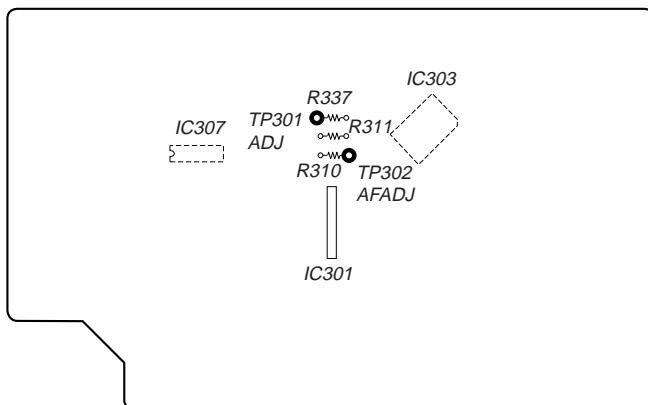

SECTION 6 DIAGRAMS

6-1. CIRCUIT BOARDS LOCATION

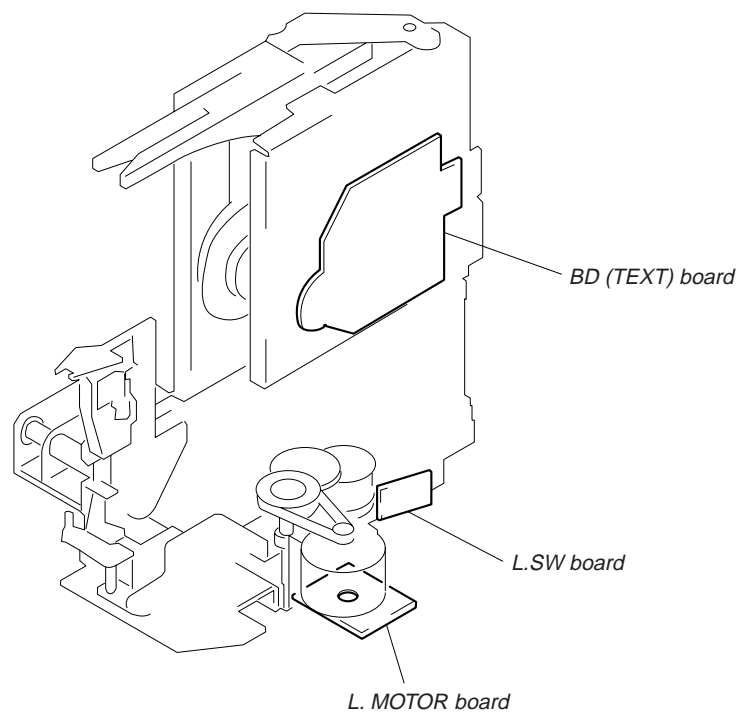
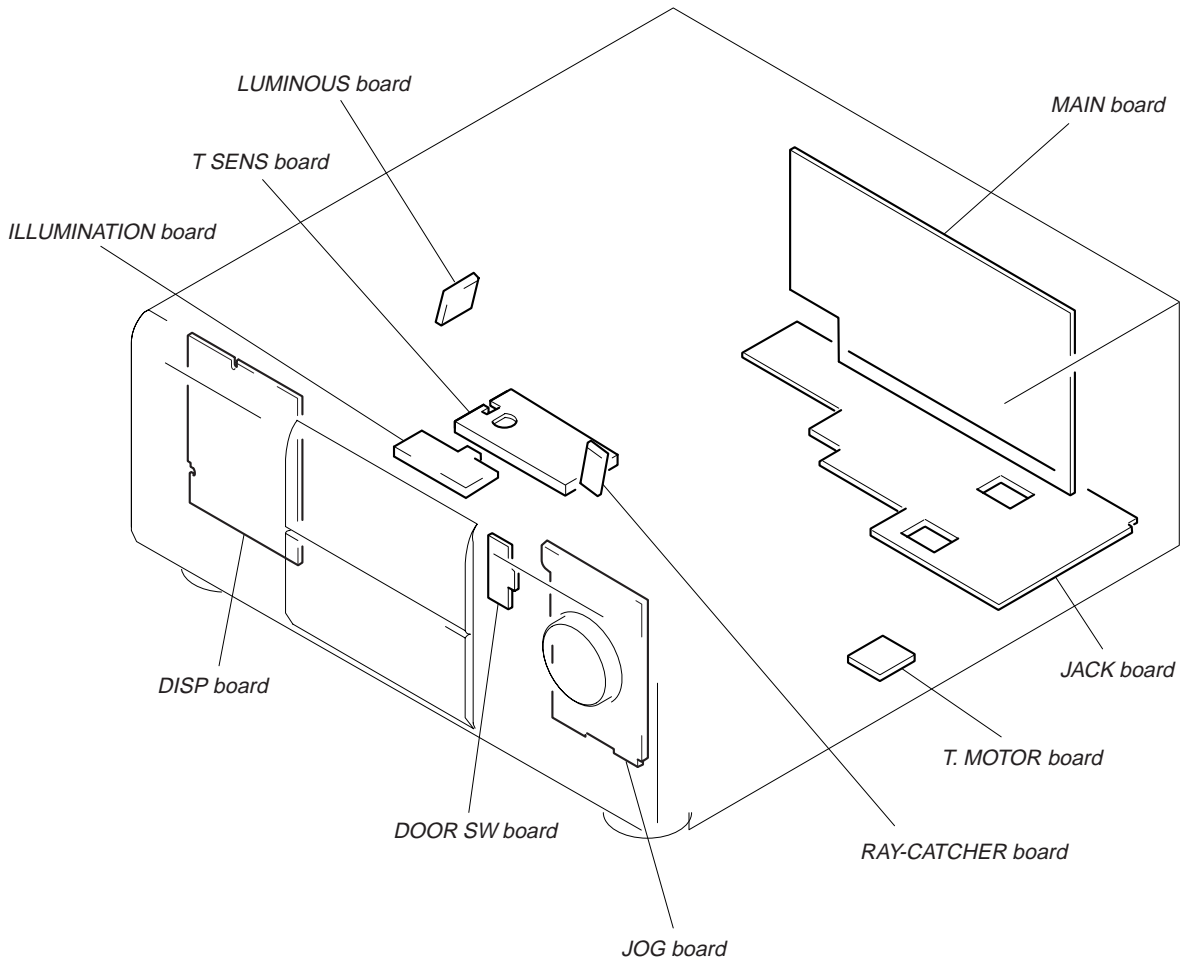

6-6. IC PIN FUNCTIONS

• IC101 DIGITAL SERVO, DIGITAL SIGNAL PROCESSOR (CXD2545Q)

Pin No.	Pin Name	I/O	Function
1	SRON	O	Sled drive output (Open)
2	SRDR	O	Sled drive output
3	SFON	O	Sled drive output (Open)
4	TFDR	O	Tracking drive output
5	TRON	O	Tracking drive output (Open)
6	TRDR	O	Tracking drive output
7	TFON	O	Tracking drive output (Open)
8	FFDR	O	Focus drive output
9	FRON	O	Focus drive output (Open)
10	FRDR	O	Focus drive output
11	FFON	O	Focus drive output (Open)
12	VCOO	O	VCO output for analog EFM PLL (Open)
13	VCOI	I	VCO input from analog EFM PLL (Connected to Ground)
14	TEST	I	TEST pin connected normally to Ground (Connected to Ground)
15	DVss	–	Digital Ground
16	TES2	I	TEST pin connected normally to Ground
17	TES3	I	TEST pin connected normally to Ground
18	PDO	O	Charge-pump output for analog EFM PLL (Open)
19	VPCO	O	Charge-pump output for variable pitch PLL (Open)
20	VCKI	I	Clock input from variable pitch external VCO (Connected to Ground)
21	AVD2	–	Analog power supply
22	IGEN	I	Power supply pin for operational amplifiers
23	AVS2	–	Analog Ground
24	ADIO	I	(Open)
25	RFC	O	(Open)
26	RFDC	I	RF signal input
27	TE	I	Tracking error signal input
28	SE	I	Sled error signal input
29	FE	I	Focus error signal input
30	VC	I	Center voltage input pin
31	FILO	O	Filter output for master PLL
32	FILI	I	Filter input for master PLL
33	PCO	O	Charge-pump output for master PLL
34	CLTV	I	Control voltage input for master VCO
35	AVS1	–	Analog Ground
36	RFAC	I	EFM signal input
37	BIAS	I	Asymmetry circuit constant current input
38	ASYI	I	Asymmetry compare voltage input
39	ASYO	O	EFM full swing output
40	AVD1	–	Analog power supply

• Abbreviation

EFM: Eight to Fourteen Modulation

PLL: Phase Locked Loop

Pin No.	Pin Name	I/O	Function
41	DVDD	–	Digital power supply
42	ASYE	I	Asymmetry circuit ON/OFF (Connected to +5V)
43	PSSL	I	Audio data output mode selection input (Connected to Ground)
44	WDCK	O	48-bit slot D/A interface. Word clock. (Open)
45	LRCK	O	48-bit slot D/A interface. LR clock.
46	DATA	O	DA 16 output when PSSL=1.48-bit slot serial data when PSSL=0
47	BCLK	O	DA 15 output when PSSL=1.48-bit slot data when PSSL=0
48	64DATA	O	DA 14 output when PSSL=1.64-bit slot data when PSSL=0 (Open)
49	64BCLK	O	DA 13 output when PSSL=1.64-bit slot data when PSSL=0 (Open)
50	64LRCK	O	DA 12 output when PSSL=1.64-bit slot data when PSSL=0 (Open)
51	GTOP	O	DA 11 output when PSSL=1.GTOP output when PSSL=0 (Open)
52	XUGF	O	DA 10 output when PSSL=1.XUGF output when PSSL=0 (Open)
53	XPLCK	O	DA 09 output when PSSL=1.XPLCK output when PSSL=0 (Open)
54	GFS	O	DA 08 output when PSSL=1.GFS output when PSSL=0 (Open)
55	PFCK	O	DA 07 output when PSSL=1.RFCK output when PSSL=0 (Open)
56	C2PO	O	DA 06 output when PSSL=1.C2PO output when PSSL=0 (Open)
57	XRAOF	O	DA 05 output when PSSL=1.XRA0F output when PSSL=0 (Open)
58	MNT3	O	DA 04 output when PSSL=1.MNT3 output when PSSL=0 (Open)
59	MNT2	O	DA 03 output when PSSL=1.MNT2 output when PSSL=0 (Open)
60	MNT1	O	DA 02 output when PSSL=1.MNT1 output when PSSL=0 (Open)
61	MNT0	O	DA 01 output when PSSL=1.MNT0 output when PSSL=0 (Open)
62	XTAI	I	X'tal oscillator circuit input
63	XTAO	O	X'tal oscillator circuit output (Open)
64	XTSL	I	X'tal selection input pin (Connected to Ground)
65	DVss	–	Digital Ground
66	FSTI	I	Clock input for digital servo block
67	FSTO	O	2/3 divider output of pins 62, 63
68	FSOF	O	1/4 divider output of pins 62, 63 (Open)
69	C16M	O	16.9344 MHz output (Open)
70	MD2	I	Digital-out ON/OFF control pin (Connected to +5V)
71	DOUT	O	Digital-out output pin
72	EMPH	O	Playback disc output in emphasis mode (Open)
73	WFCK	O	WFCK output
74	SCOR	O	Sub-code sync output
75	SBSO	O	Sub-P through Sub-W serial output
76	EXCK	I	Clock input for SBSO read-out
77	SUBQ	O	Sub-Q 80-bit output
78	SQCK	I	Clock input for SQSO read-out
79	MUTE	I	Muting selection pin
80	SENS	O	SENS output

- Abbreviation

WFCK: Wirte Frame Clock

Pin No.	Pin Name	I/O	Function
81	XRST	I	System reset
82	DIRC	I	Used in 1-track jump mode (Connected to +5v)
83	SCLK	I	SENS serial data read-out clock
84	DFSW	I	Defect selection pin (Connected to Ground)
85	ATSK	I	Input pin for anti-shock (Connected to Ground)
86	DATA	I	Serial data input, supplied from CPU
87	XLAT	I	Latch input, supplied from CPU
88	CLOCK	I	Serial data transfer clock input, supplied from CPU
89	COUT	O	Numbers of track counted signal output (Open)
90	DVDD	–	Digital power supply
91	MIRR	O	Mirror signal output (Open)
92	DFCT	O	Defect signal output (Open)
93	FOK	O	Focus OK output (Open)
94	FSW	O	Output to select spindle motor output filter (Open)
95	MON	O	Output to control ON/OFF of spindle motor (Open)
96	MDP	O	Output to control spindle motor servo
97	MDS	O	Output to control spindle motor servo (Open)
98	LOCK	O	GFS is sampled by 460 Hz. H when GFS is H (Open)
99	SSTP	I	Input signal to detect disc inner most track
100	SFDR	O	Sled drive output

- Abbreviation
GFS: Guard Frame Sync

• IC303 SYSTEM CONTROL (CXD84332-027Q)

Pin No.	Pin Name	I/O	Function
1	A3	O	SRAM address
2	A4	O	SRAM address
3	A5	O	SRAM address
4	A6	O	SRAM address
5	A7	O	SRAM address
6	A12	O	SRAM address
7	A14	O	SRAM address
8	A11	O	SRAM address
9	A10	O	SRAM address
10	A9	O	SRAM address
11	A8	O	SRAM address
12	A13	O	SRAM address
13	$\overline{\text{WE}}$	O	SRAM write enable
14	LED1	O	PLAY LED control H: Lighting up
15	LED2	O	PAUSE LED control L: Lighting up
16	CE	O	SRAM enable
17	DOOR SW	I	Front foor switch H: Open
18	SCLK	O	Clock for CD-TEXT
19	SRDT	I	CD-TEXT data
20	MODE	O	CD-TEXT IC control H: Active
21	BUSOUT	O	CONTROL-A1 out
22	LDOUT	O	Loading motor PWM output for outside direction
23	LDIN	O	Loading motor PWM output for inside direction
24	TBL.L	O	Table motor PWM output for left turn
25	TBL.R	O	Table motor PWM output for right turn
26	S.RST	O	Power control H: Power ON
27	FL.DATA	O	Data for fluorescent indicator and LED control
28	FL.CLK	O	Clock for fluorescent indicator and LED control
29	LDON	O	Laaser diode control H: ON
30	RESET	I	Reset input L: Reset
31	EXTAL	O	X'tal Oscillation (10MHz)
32	XTAL	I	X'tal Oscillation (10MHz)
33	Vss	-	Connect to ground
34	TX	-	Open
35	TEX	-	Connect to ground
36	AVss	-	Connect to ground
37	AVREF	-	Connect to +5V
38	I.SENS	I	Table motor current detect More than 3V: Avnormal condition
39	CD 1/2/3	I	Command mode switch
40	D.SENS	I	Disc sensor input Less than 3V: Existing disc

Pin No.	Pin Name	I/O	Function
41	KEY2	I	Key input
42	KEY1	I	Key input
43	KEY0	I	Key input
44	XLT	O	Latch for servo IC
45	AFADJ ADJ	I	Type switching and test mode input.
46	BUSIN	I	CONTROL-A1 input L: Active
47	PRGLT	O	Latch for digital filter IC
48	CLK	O	Clock for servo IC and digital filter IC
49	AMUTE	O	Audio mute H: Mute ON
50	DATA	O	Data for servo IC and digital filter IC
51	SQCK	O	Clock for sub code Q
52	SUBQ	I	Sub code Q data input
53	NC	–	Open
54	SENSE	I	Servo sensor signal
55	JOG2	I	Jog input
56	RMIN	I	Remote control signal
57	JOG1	I	Jog input
58	LEDLT	O	Latch for LED driver IC
59	FLT	O	Latch for fluorescent indicator driver IC
60	DQSY	O	Synchronous signal for CD-TEXT
61	SCOR	O	Sub code Q synchronous signal Start at rising edge
62	T.SENS1	I	Table position sensor 1 input
63	T.SENS2	I	Table position sensor 2 input
64	T.SENS3	I	Table position sensor 3 input
65	DOWN SW	I	Loading out switch input L: Out
66	UPSW	I	Loading in switch input L: In
67	BLK	O	Reset for fluorescent indicator driver IC
68	D3	I/O	SRAM data
69	D4	I/O	SRAM data
70	D5	I/O	SRAM data
71	D6	I/O	SRAM data
72	VDD	–	Connect to +5V
73	NC (VDD)	–	Connect to +5V
74	D7	I/O	SRAM data
75	D0	I/O	SRAM data
76	D1	I/O	SRAM data
77	D2	I/O	SRAM data
78	A0	O	SRAM address
79	A1	O	SRAM address
80	A2	O	SRAM address

6-3. BLOCK DIAGRAM

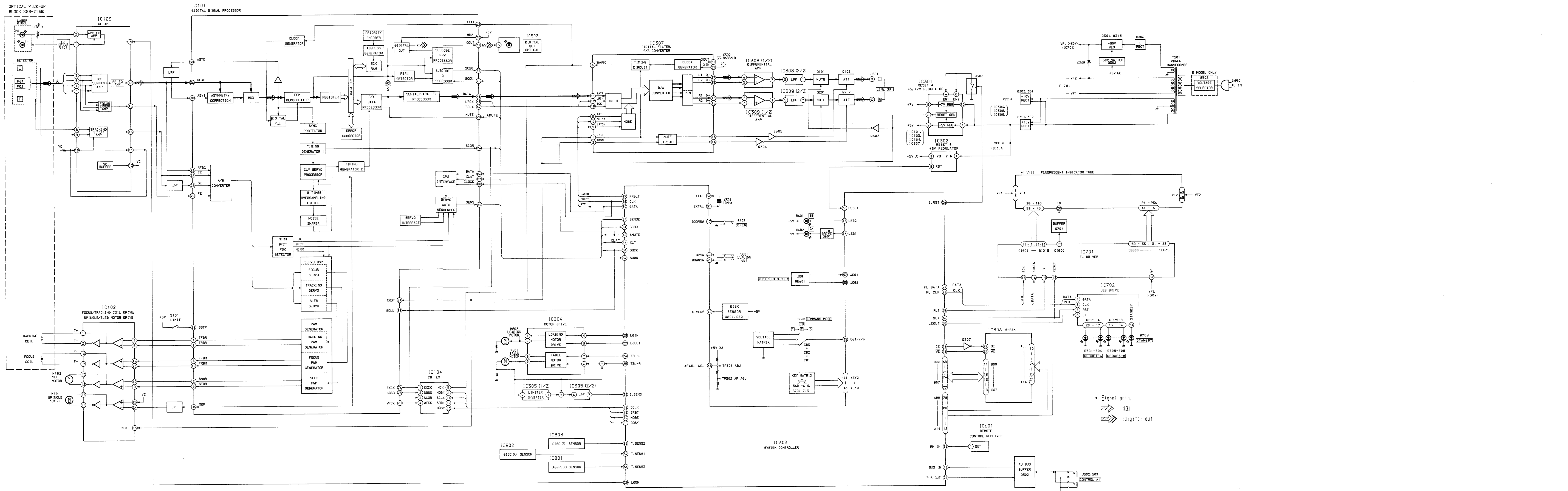

09

6-4. PRINTED WIRING BOARD — BD, DISP SECTION —
 • See page 24 for Circuit Boards Location.

• Semiconductor Location

Ref. No.	Location
D601	C-14
D602	C-13
D701	C-20
D702	C-21
D703	C-21
D704	C-22
D705	B-20
D706	B-20
D707	B-21
D708	B-22
D709	D-18
IC101	C-9
IC102	B-3
IC103	A-9
IC104	C-5
IC601	G-13
IC701	F-21
IC702	D-22
Q101	A-4
Q601	C-13
Q701	E-19

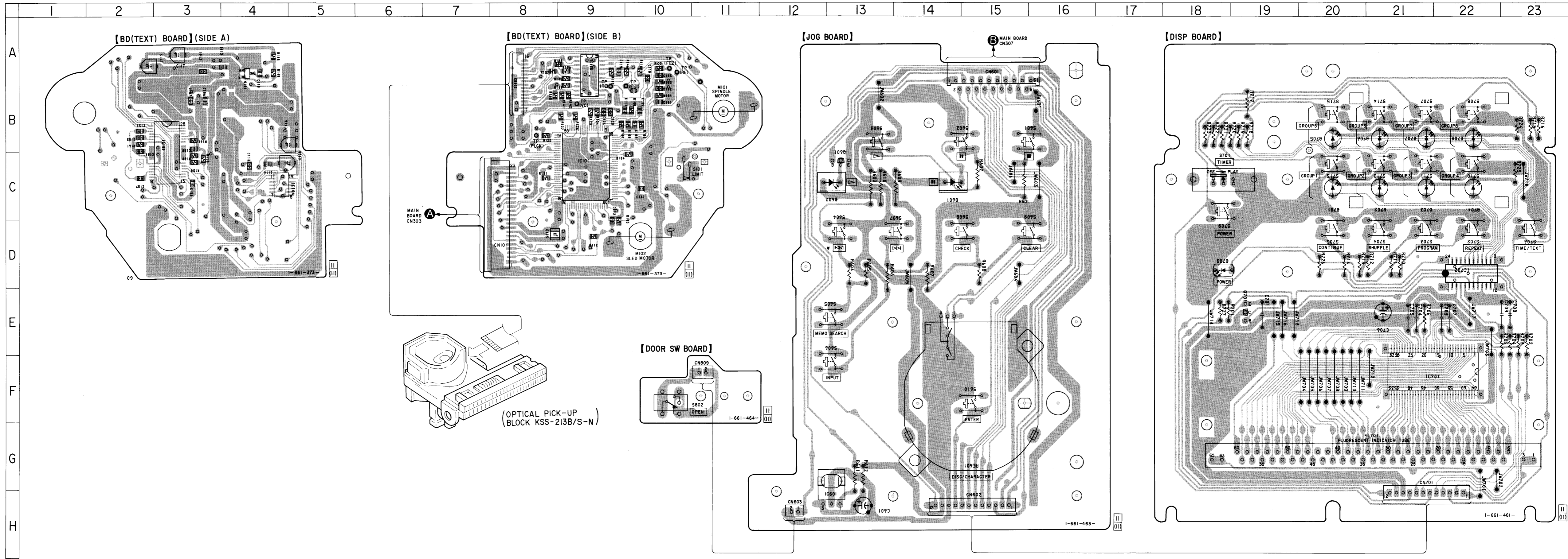

Note:
 • — : parts extracted from the component side.
 • ○ : Through hole.
 • ■ : Pattern from the side which enable seeing.
 (The other layer's patterns are not indicated.)
 • ⊘ : Solder bridge.

6-5. SCHEMATIC DIAGRAM — BD, DISP SECTION —

- See page 51 for IC Block Diagrams.
- See page 25 for IC Pin Functions. (IC101)

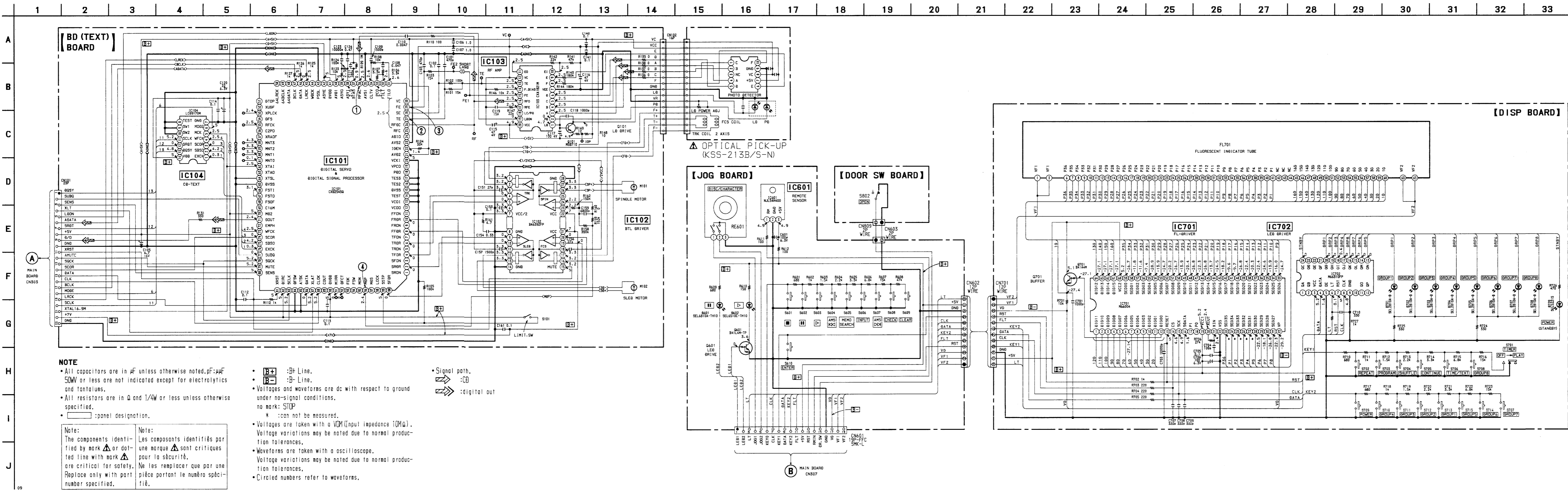

NOTE

- All capacitors are in μF unless otherwise noted. μF : μF 50WV or less are not indicated except for electrolytics and tantalums.
- All resistors are in Ω and $1/4\text{W}$ or less unless otherwise specified.
- [] : panel designation.

• [B+] : B+ Line.
 • [B-] : B- Line.
 • Voltages and waveforms are dc with respect to ground under no-signal conditions. no mark: STOP
 * : can not be measured.
 • Voltages are taken with a VOM (input impedance $10\text{M}\Omega$). Voltage variations may be noted due to normal production tolerances.
 • Waveforms are taken with an oscilloscope. Voltage variations may be noted due to normal production tolerances.
 • Circled numbers refer to waveforms.

• Signal path.
 • [] : CO
 • [] : digital out

Note: The components identified by mark Δ or dotted line with mark Δ are critical for safety. Replace only with part number specified.

Les composants identifiés par une marque Δ sont critiques pour la sécurité. Ne les remplacer que par une pièce portant le numéro spécifié.

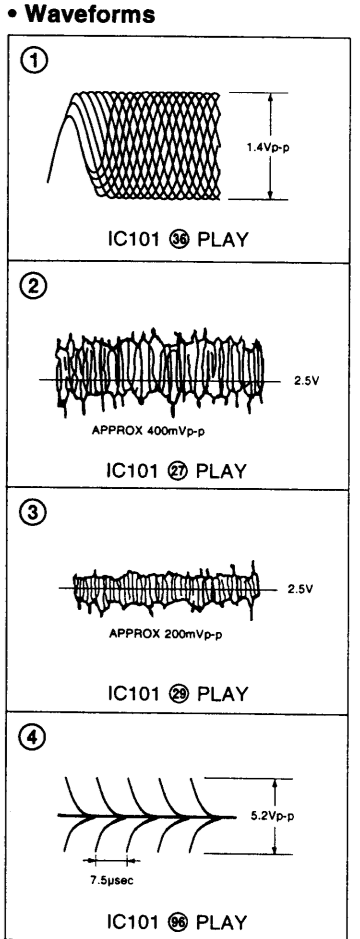

6-6. PRINTED WIRING BOARD — MAIN SECTION —

• See page 24 for Circuit Boards Location.

• Semiconductor Location

Ref. No.	Location
D301	G-21
D302	G-21
D303	G-20
D304	G-20
D305	G-19
D306	G-19
D307	G-18
D308	F-18
D309	C-18
D310	C-17
D311	B-17
D312	G-22
D313	G-21
D314	F-22
D315	G-19
D316	D-19
D501	C-13
D601	
D801	F-9
D802	E-12
D803	E-12
D804	E-13
IC301	E-22
IC302	E-21
IC303	C-20
IC304	D-17
IC305	F-18
IC306	C-19
IC307	D-24
IC308	F-25
IC309	F-24
IC502	A-15
IC801	G-12
IC802	G-13
IC803	H-13
Q101	G-25
Q102	G-25
Q201	G-24
Q202	G-24
Q301	F-19
Q302	F-19
Q303	G-23
Q304	G-23
Q305	G-22
Q306	D-20
Q307	B-18
Q502	B-13
Q801	H-9

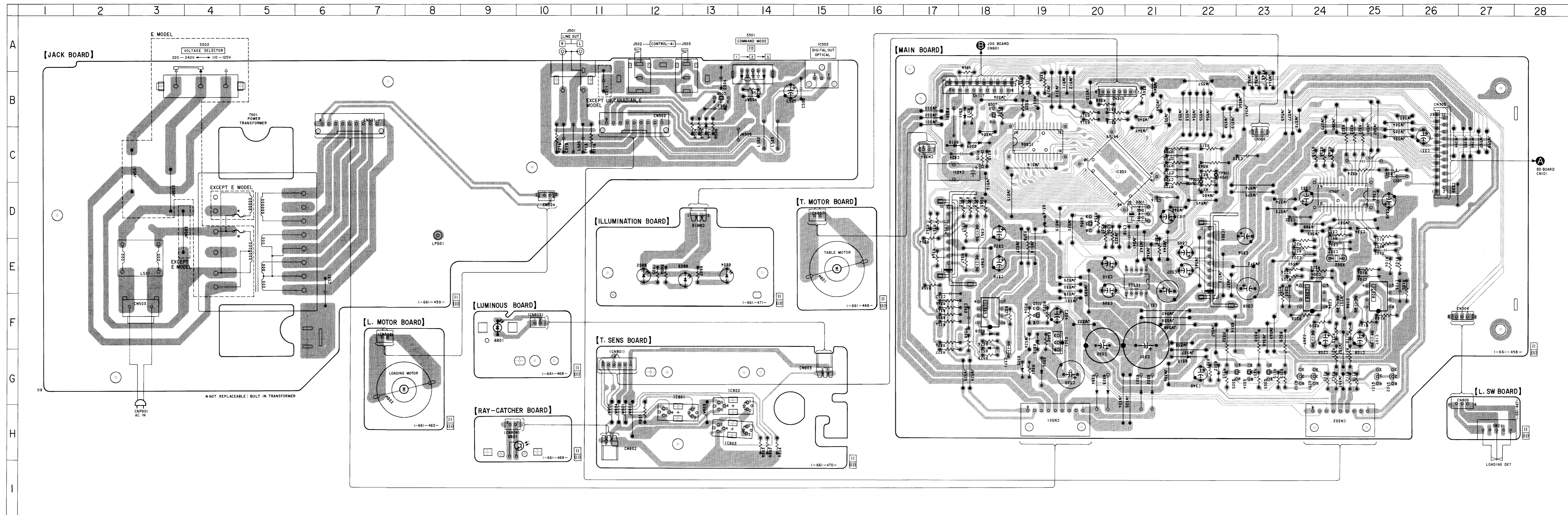

Note:
 ○ : parts extracted from the component side.
 △ : internal component.
 ■ : Pattern from the side which enable seeing.

6-7. SCHEMATIC DIAGRAM — MAIN SECTION—

- See page 53 for IC Block Diagrams.
- See page 28 for IC Pin Functions. (IC303)

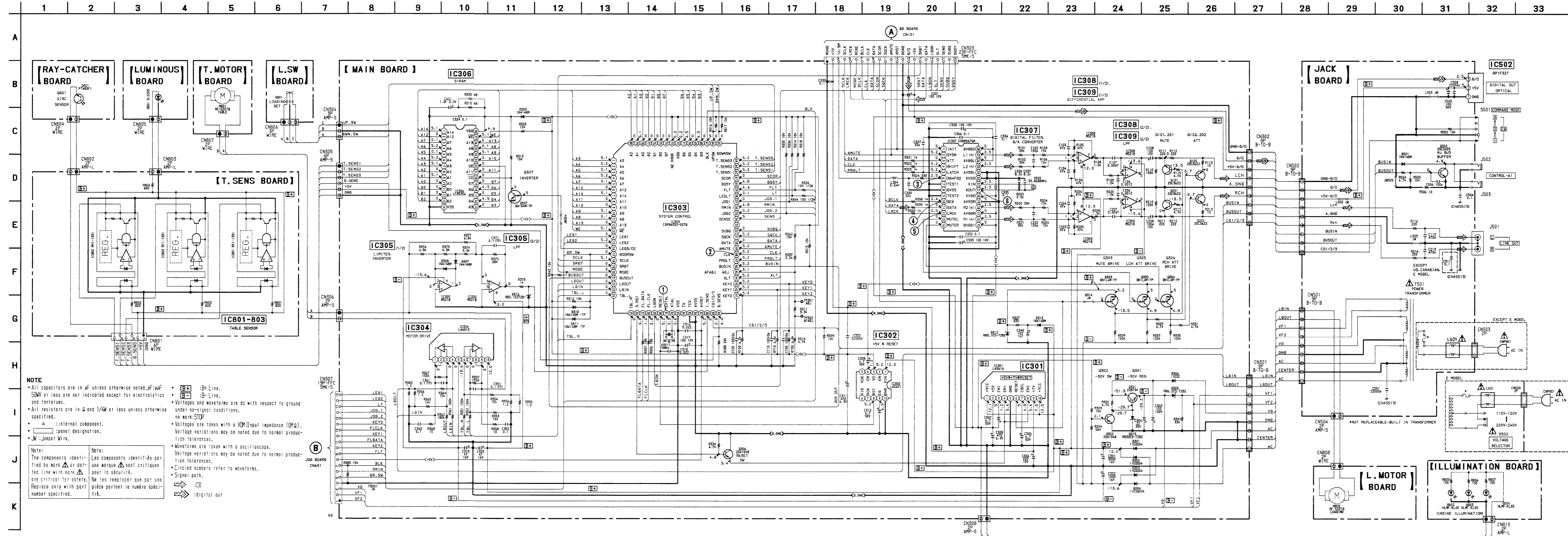

NOTE

All capacitors are in μF unless otherwise noted. pF: pF
 50W or less are not indicated except for electrolytics and tantalums.
 All resistors are in Ω and 1/4W or less unless otherwise specified.
 Δ : internal component.
 \square : panel designation.
 JW: Jumper Wire.

Note: The components identified by mark Δ or dotted line with mark Δ are critical for safety. Replace only with part number specified.

Note: Les composants identifiés par une marque Δ sont critiques pour la sécurité. Ne les remplacer que par une pièce portant le numéro spécifié.

Legend:

- \oplus Line.
- \ominus Line.
- Voltages and waveforms are dc with respect to ground under no-signal conditions.
- Voltages are taken with a VOM (input impedance 10M Ω). Voltage variations may be noted due to normal production tolerances.
- Waveforms are taken with an oscilloscope. Voltage variations may be noted due to normal production tolerances.
- Circled numbers refer to waveforms.
- Signal path.
- \Rightarrow : digital out

Waveforms

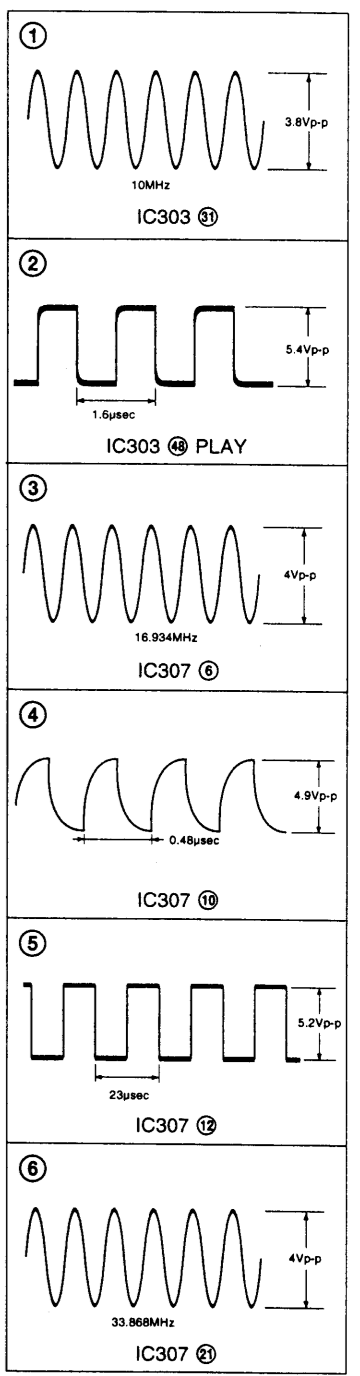

6-8. IC BLOCK DIAGRAMS
• BD, DISP Section

IC101 CXD2545Q

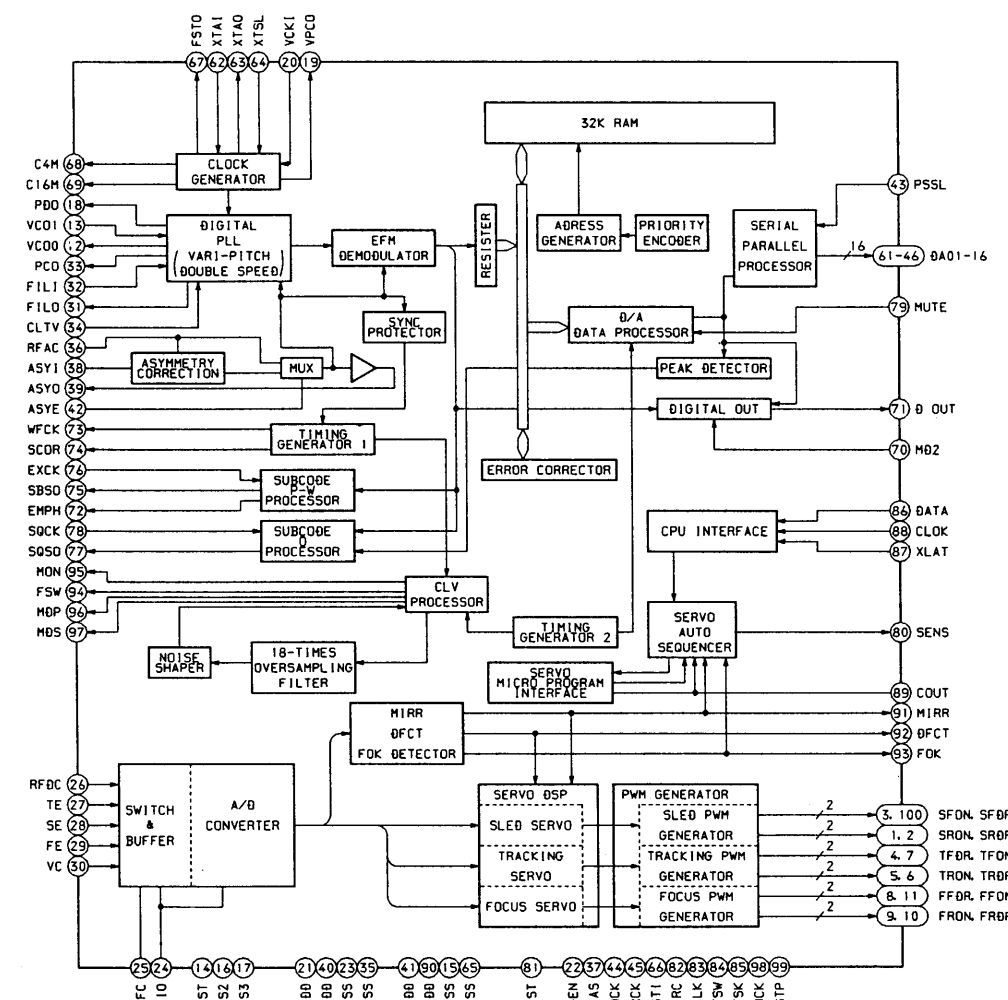

IC103 CXA1821M

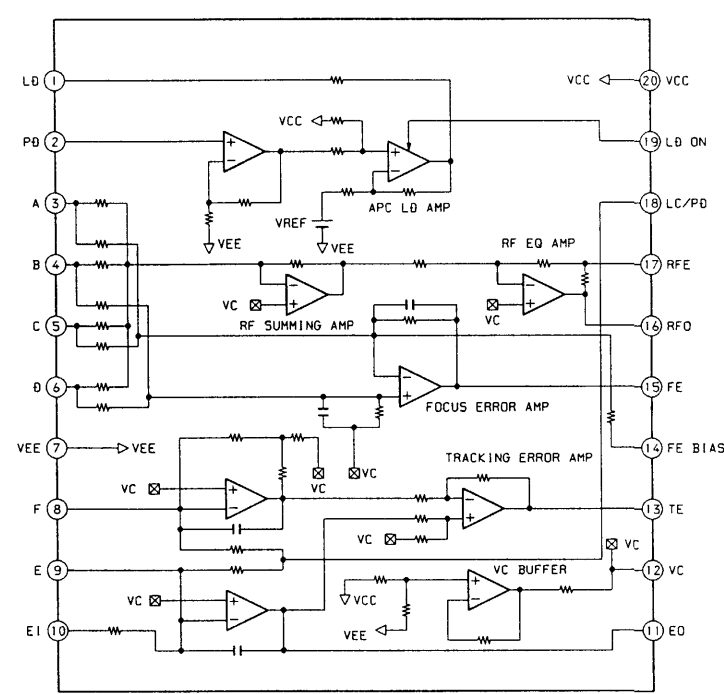

IC701 M66004M5FP

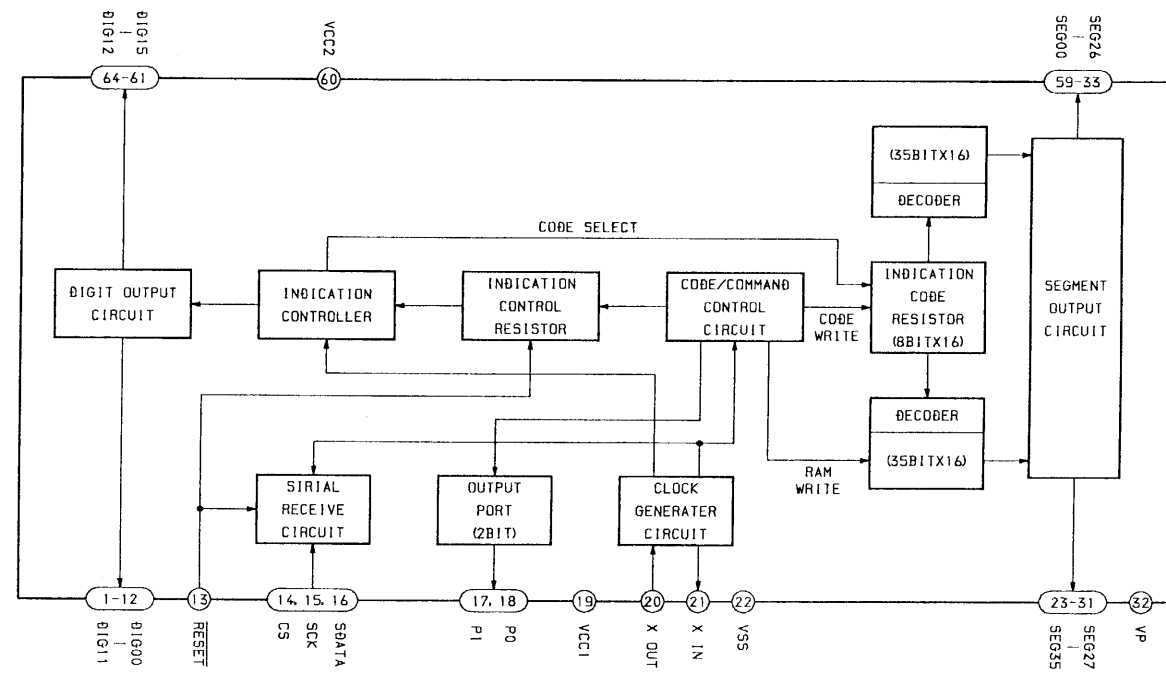

IC702 M66310FP

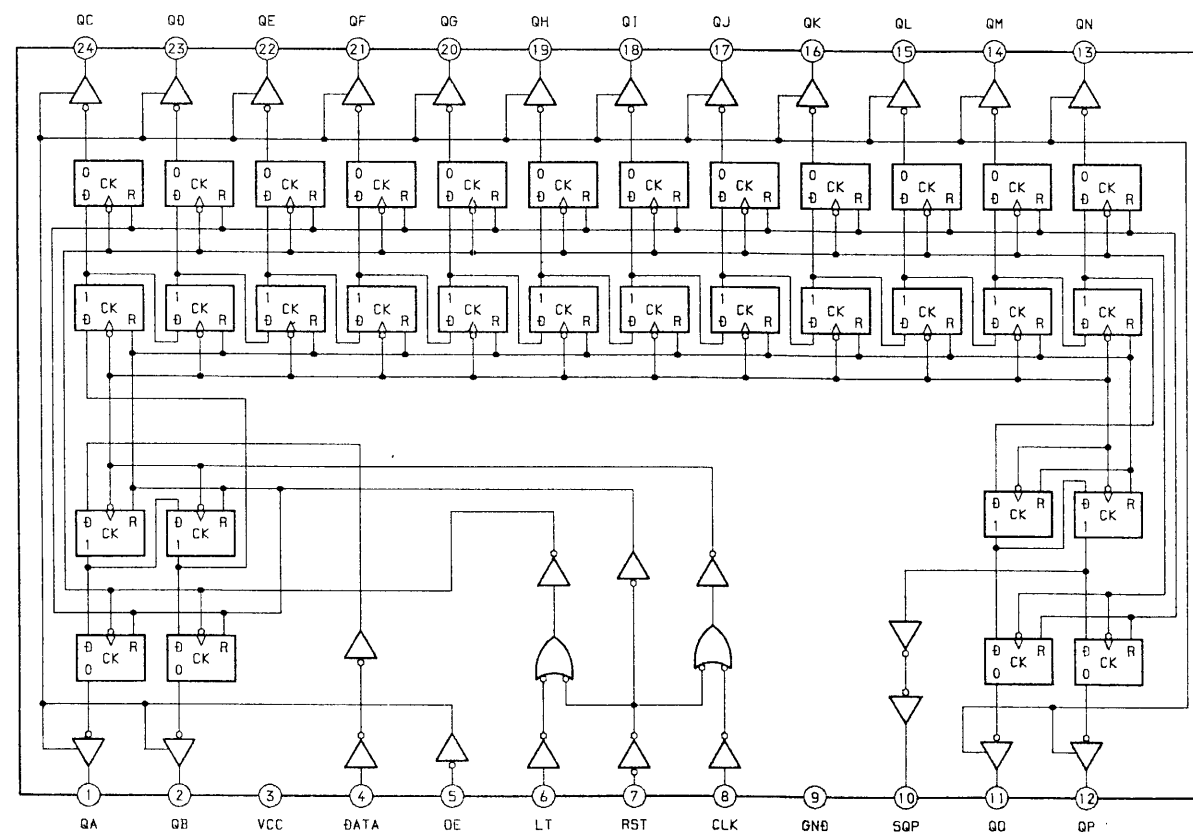

IC104 LC89170M

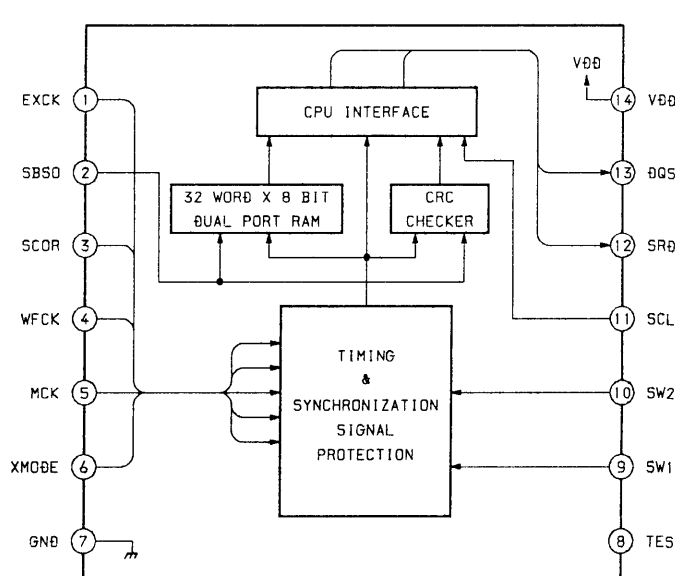

IC102 BA6392FP

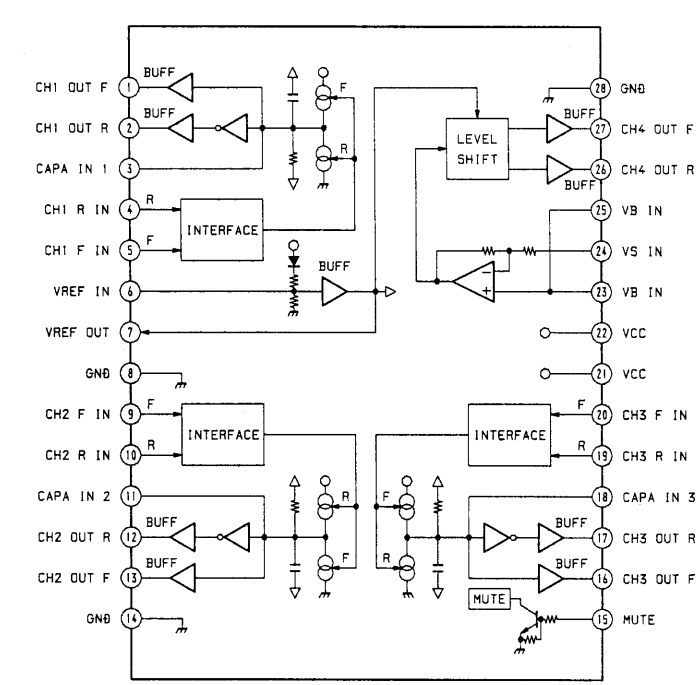

• MAIN Section

IC301 LA5616

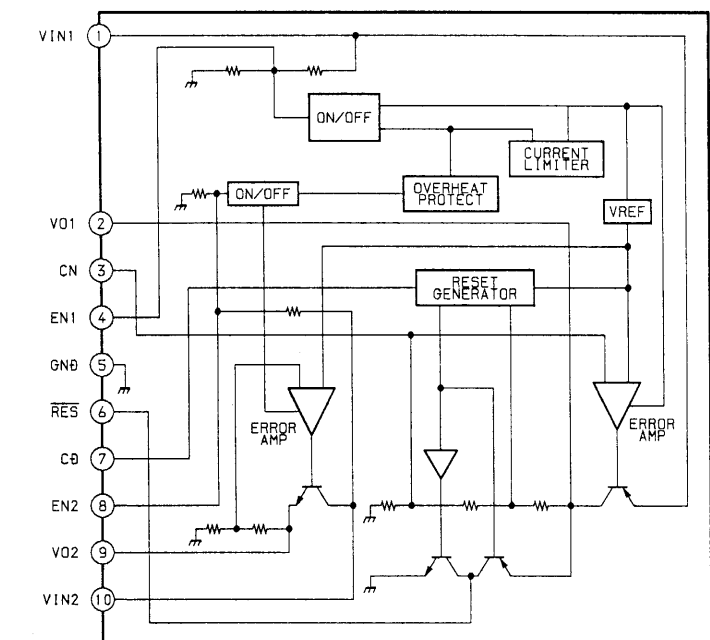

IC302 LA5601

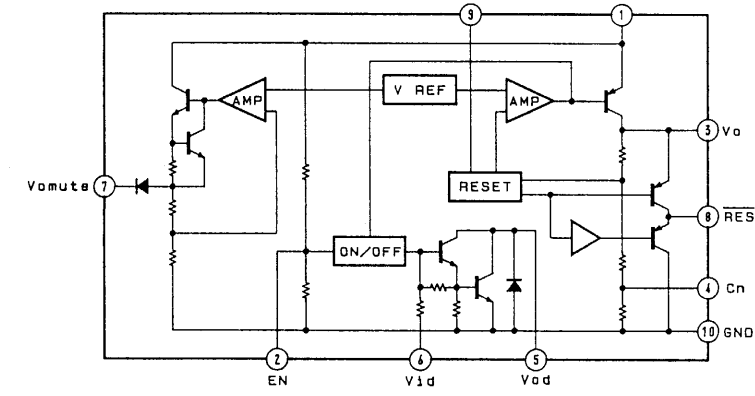

IC307 CXD8567AM

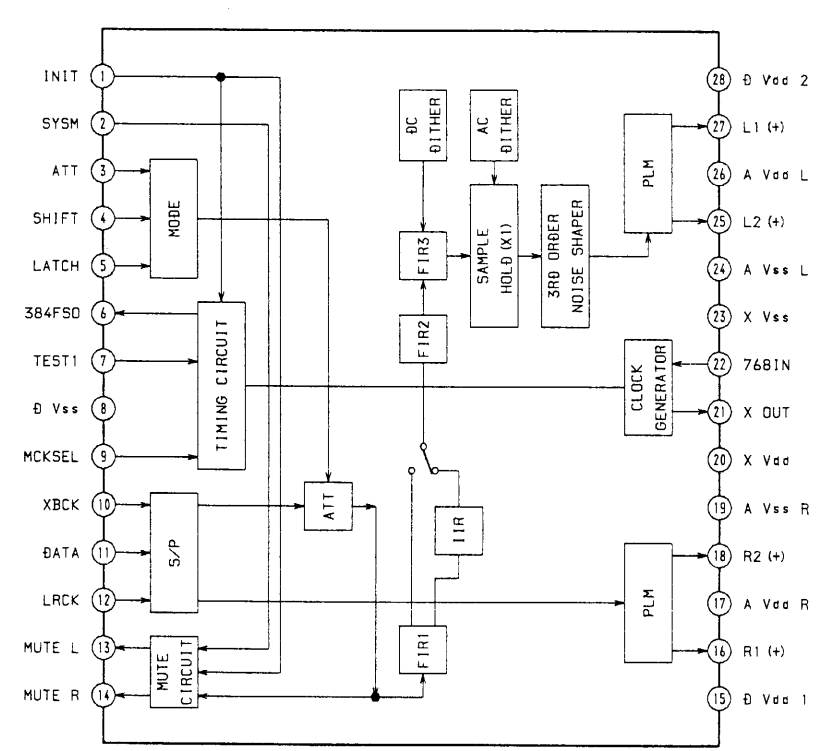

SECTION 7 EXPLODED VIEWS

NOTE:

- Items marked “*” are not stocked since they are seldom required for routine service. Some delay should be anticipated when ordering these items.
- The mechanical parts with no reference number in the exploded views are not supplied.
- Hardware (# mark) list and accessories and packing materials are given in the last of this parts list.

- Abbreviation
 CND : Canadian model
 G : German model
 SP : Singapore model
 AUS : Australian model

The components identified by mark Δ or dotted line with mark Δ are critical for safety. Replace only with part number specified.

Les composants identifiés par une marque Δ sont critiques pour la sécurité. Ne les remplacer que par une pièce portant le numéro spécifié.

7-1. CASE AND BACK PANEL SECTION

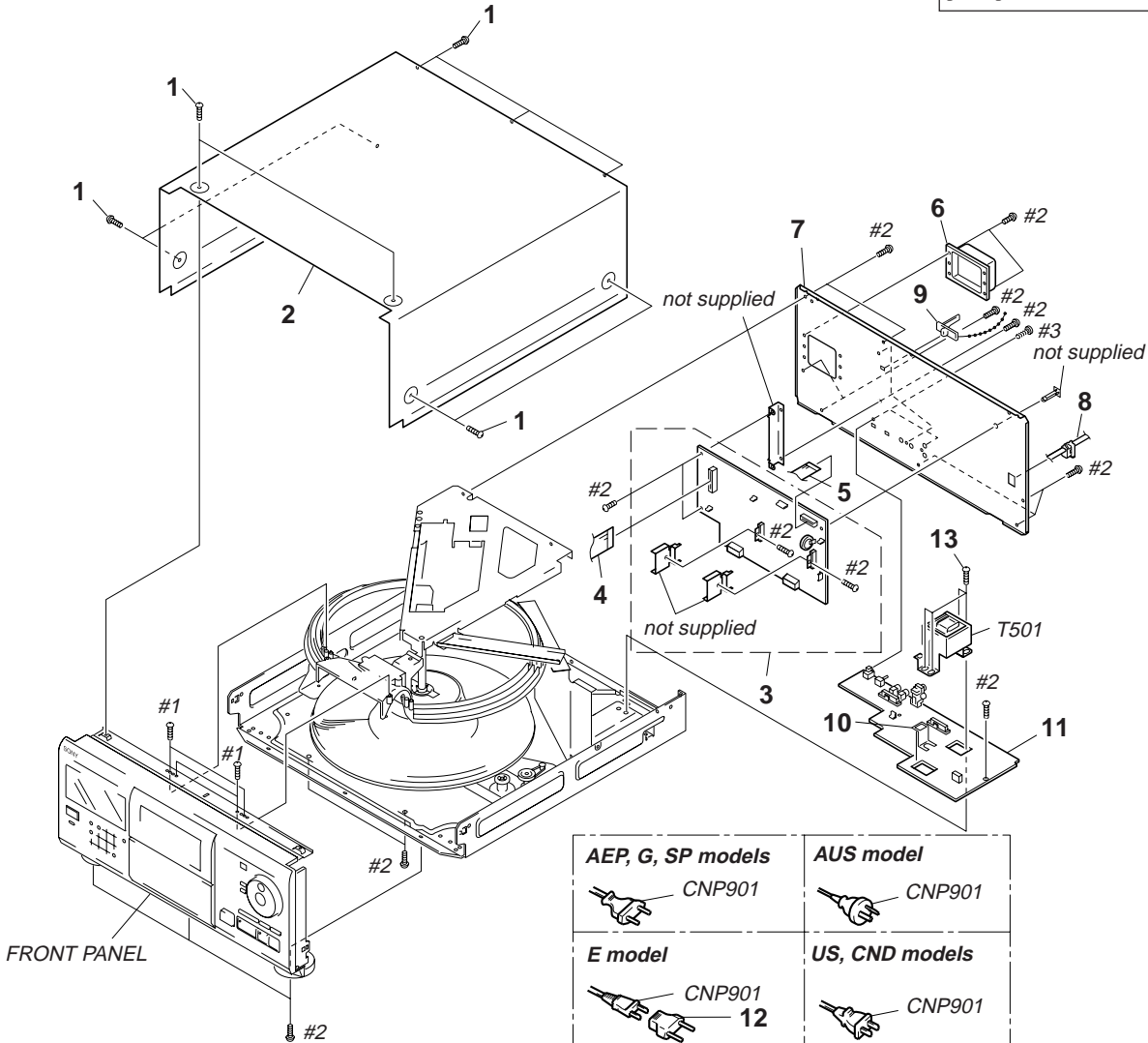

Ref. No.	Part No.	Description	Remark
1	3-363-099-01	SCREW (CASE 3 TP2)	
* 2	4-982-946-11	CASE	
* 3	A-4699-040-A	MAIN BOARD, COMPLETE (US,CND)	
* 3	A-4699-041-A	MAIN BOARD, COMPLETE (EXCEPT US,CND)	
4	1-773-183-11	WIRE (FLAT TYPE) (23 CORE)	
5	1-777-345-11	WIRE (FLAT TYPE) (19 CORE)	
* 6	4-982-807-01	COVER (FFC)	
* 7	4-982-813-01	PANEL, BACK (US)	
* 7	4-982-813-11	PANEL, BACK (CND)	
* 7	4-982-813-21	PANEL, BACK (AEP,G)	
* 7	4-982-813-31	PANEL, BACK (E)	
* 7	4-982-813-41	PANEL, BACK (SP)	
* 7	4-982-813-51	PANEL, BACK (AUS)	

AEP, G, SP models	AUS model
CNP901	CNP901
E model	US, CND models
CNP901	CNP901
12	

Ref. No.	Part No.	Description	Remark
* 8	3-703-244-00	BUSHING (2104), CORD (EXCEPT E)	
8	3-703-571-11	BUSHING (S) (4516), CORD (E)	
9	4-956-370-12	BAND, PLUG FIXED (AUS)	
* 10	4-962-200-01	PLATE (TR), GROUND	
* 11	1-661-459-11	JACK BOARD	
12	1-569-007-11	ADAPTOR, CONVERSION 2P (E)	
13	4-886-821-11	SCREW, M3 CASE	
Δ CNP901	1-575-042-21	CORD, POWER (US,CND)	
Δ CNP901	1-575-651-21	CORD, POWER (AEP,G,SP)	
Δ CNP901	1-696-027-11	CORD, POWER (E)	
Δ CNP901	1-696-845-11	CORD, POWER (AUS)	
Δ T501	1-429-666-11	TRANSFORMER, POWER (US,CND)	
Δ T501	1-429-667-11	TRANSFORMER, POWER (AEP,G,AUS,SP)	
Δ T501	1-429-669-11	TRANSFORMER, POWER (E)	

7-2. DISC TABLE SECTION

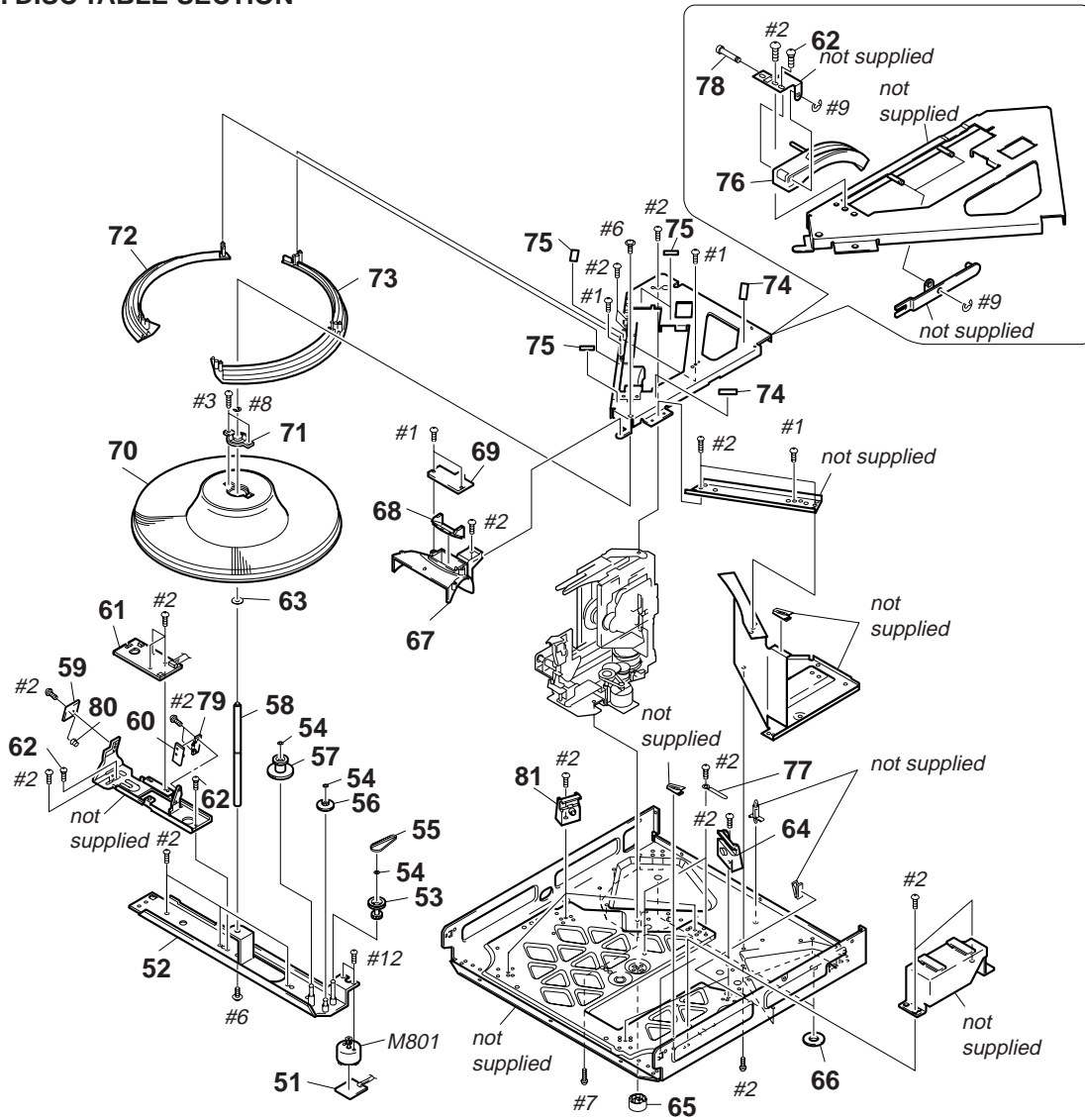

Ref. No.	Part No.	Description	Remark	Ref. No.	Part No.	Description	Remark
* 51	1-661-466-11	T. MOTOR BOARD		* 67	4-982-804-01	COVER (DISC)	
52	X-4947-230-1	BRACKET (TABLE) ASSY		68	4-982-805-01	INDICATOR (INTERNAL)	
53	X-4947-607-1	GEAR (PULLEY) ASSY		* 69	1-661-471-11	ILLUMINATION BOARD	
54	3-325-697-21	WASHER		70	X-4947-231-1	TABLE (200) ASSY	
55	4-982-867-01	BELT (TIMING)		71	4-976-471-01	BEARING (TABLE)	
56	4-982-893-01	GEAR (CENTER 2)		* 72	4-982-803-01	RING (B)	
57	4-982-891-01	GEAR (TABLE)		* 73	4-982-802-01	RING (A)	
58	4-982-892-01	SHAFT (CENTER)		* 74	3-378-433-01	CUSHION, SARANET	
* 59	1-661-468-11	LUMINOUS BOARD		75	4-985-553-01	CUSHION	
* 60	1-661-469-11	RAY-CATCHER BOARD		76	4-982-862-01	GUIDE (DISC T)	
* 61	1-661-470-11	T.SENS BOARD		77	3-703-397-01	STOPPER, WIRING	
62	3-356-601-11	SCREW, STEP		78	4-982-870-01	SHAFT (GUIDE FULCRUM)	
63	3-701-446-21	WASHER, 8		* 79	4-985-300-01	HOLDER (P-T)	
64	X-4947-229-1	HOLDER (ROLLER) ASSY		* 80	4-976-473-01	HOLDER (LED-S)	
65	4-931-169-01	FOOT		81	X-4947-606-1	HOLDER (ROLLER 2) ASSY	
66	4-983-279-01	CUSHION (RF)		M801	A-4604-847-A	MOTOR ASSY, LOADING (TABLE)	

7-3. FRONT PANEL SECTION

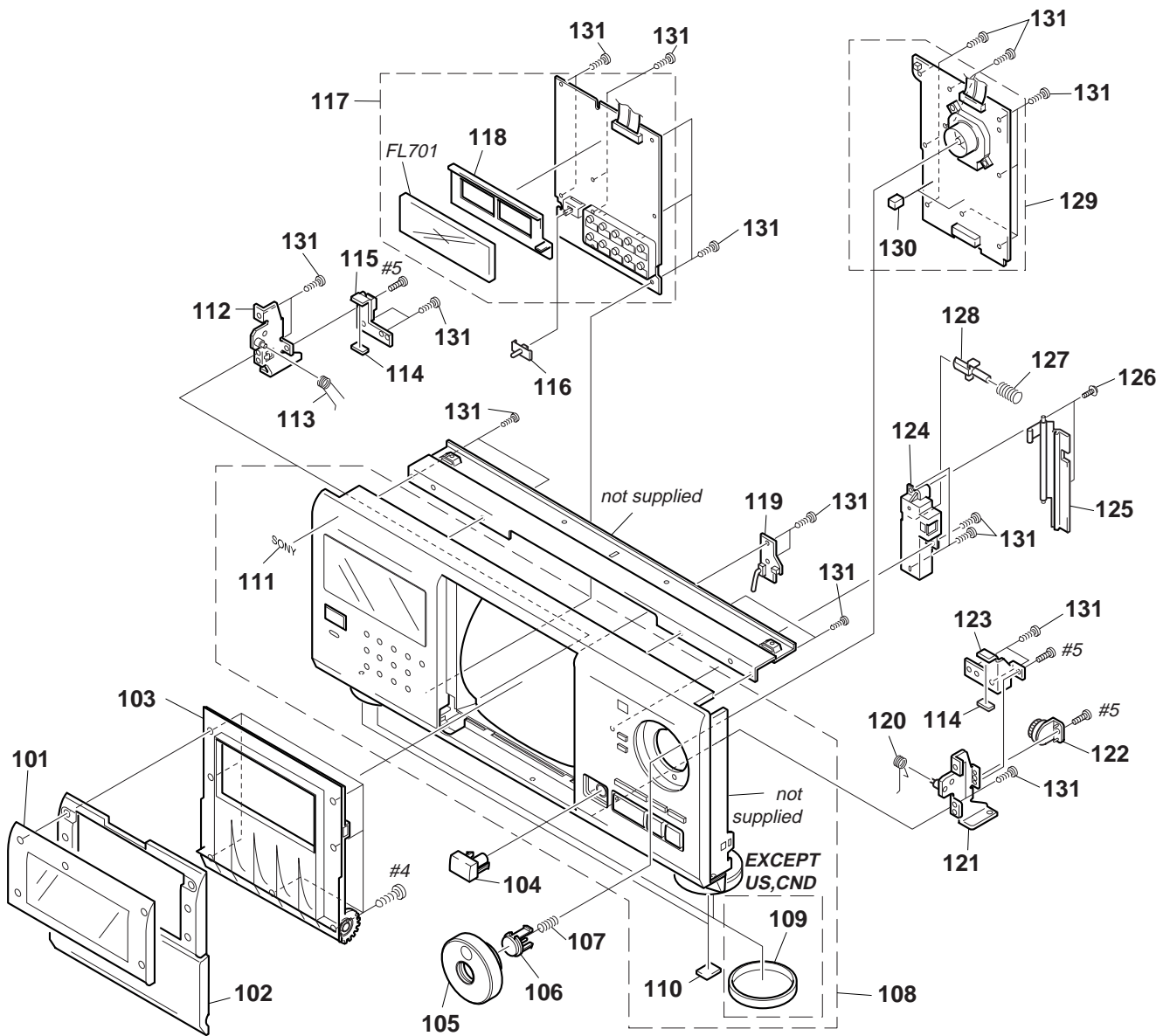

Ref. No.	Part No.	Description	Remark	Ref. No.	Part No.	Description	Remark
101	4-982-780-01	WINDOW (LID)		116	3-917-216-21	KNOB (TIMER)	
102	4-982-778-01	LID (F)		* 117	A-4699-047-A	DISP BOARD, COMPLETE	
103	4-982-779-01	LID (R)		* 118	4-982-811-01	HOLDER (FL)	
104	4-982-781-01	BUTTON (OPEN)		* 119	1-661-464-11	DOOR SW BOARD	
105	4-982-787-01	KNOB (JOG)					
106	4-982-788-01	BUTTON (ENTER)		120	4-982-798-11	SPRING (B), TORSION	
107	4-984-085-01	SPRING (ENTER), COIL		121	X-4947-220-1	PLATE (B) ASSY, FULCRUM	
108	X-4947-221-1	PANEL ASSY, FRONT (US,CND)		122	3-354-963-01	DAMPER	
108	X-4947-360-1	PANEL ASSY, FRONT (EXCEPT US,CND)		* 123	4-982-794-01	STOPPER (B)	
109	4-977-593-11	RING (DIA. 50), ORNAMENTAL (EXCEPT US,CND)		* 124	4-982-782-01	HOLDER (OPEN)	
110	4-977-358-11	CUSHION (8X12.5)		* 125	4-982-783-01	LEVER (WINDMILL)	
111	4-963-404-21	EMBLEM (5-A), SONY		126	4-933-134-01	SCREW (+PTPWH M2.6X6)	
112	X-4947-219-1	PLATE (A) ASSY, FULCRUM		127	4-982-785-01	SPRING (OPEN), COMPRESSION	
113	4-982-797-11	SPRING (A), TORSION		128	4-982-784-01	LEVER (LOCK)	
114	4-982-799-01	CUSHION (STOPPER)		* 129	A-4699-046-A	JOG BOARD, COMPLETE	
* 115	4-982-793-01	STOPPER (A)		* 130	4-982-812-01	HOLDER (LED)	
				131	4-951-620-01	SCREW (2.6X8), +BVTP	
				FL701	1-517-564-11	INDICATOR TUBE, FLUORESCENT	

7-4. MECHANISM SECTION-1 (CDM-40)

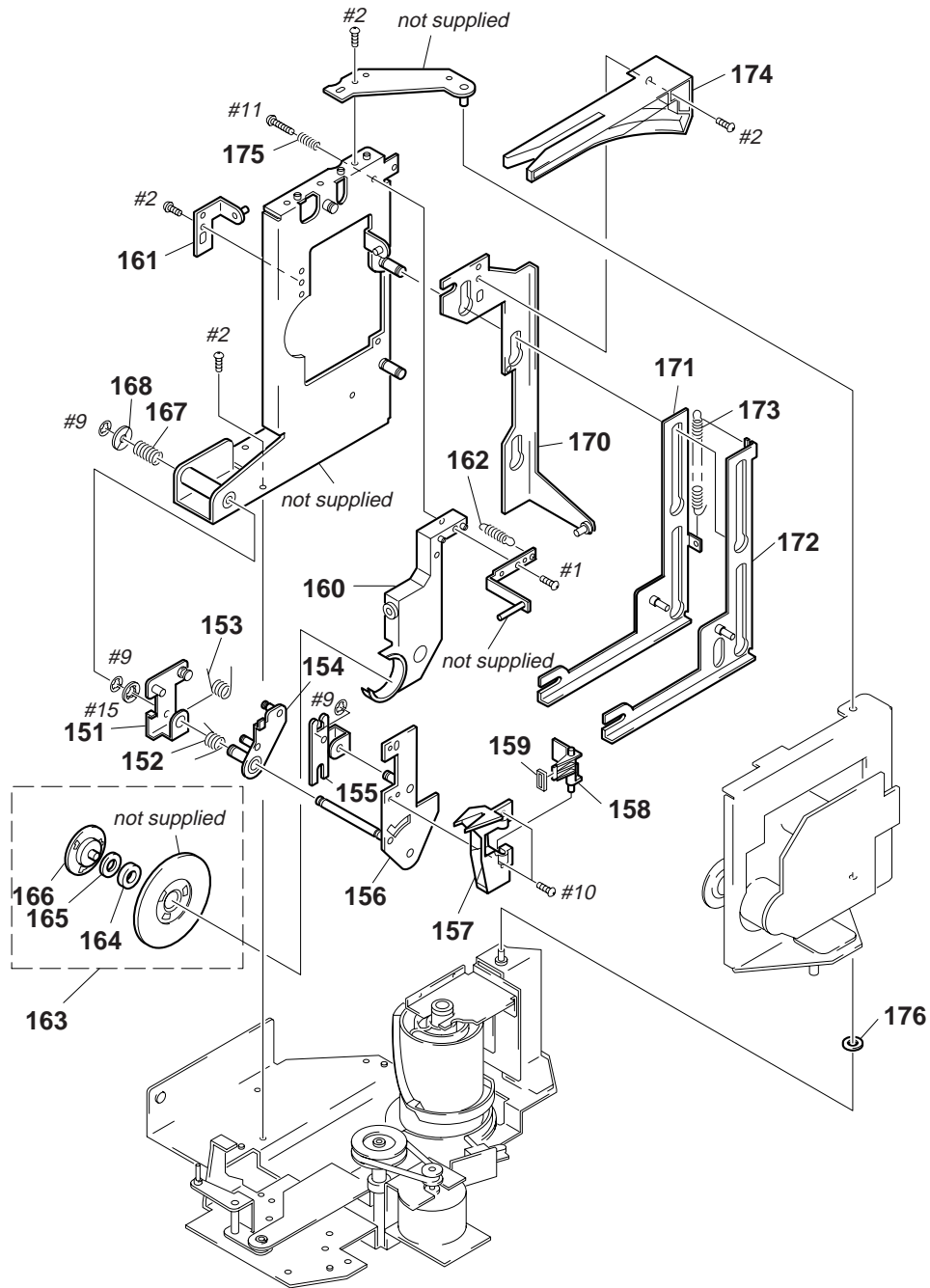

Ref. No.	Part No.	Description	Remark	Ref. No.	Part No.	Description	Remark
151	X-4947-241-1	LEVER (C) ASSY		164	3-366-559-02	MAGNET (CHUCK)	
152	4-982-882-01	SPRING (LIMITTER), TORSION		165	4-960-633-01	YOKE (MAGNET)	
153	4-982-881-01	SPRING (HOLDER), TORSION		166	4-960-632-11	PULLEY (B)	
154	X-4947-239-1	LIMITTER (A) ASSY		167	4-983-319-01	SPRING (THRUST), COMPRESSION	
155	4-982-853-01	LEVER (B)		* 168	4-976-456-01	WASHER (STOPPER)	
156	X-4947-240-1	LEVER (A) ASSY		170	X-4947-242-1	SLIDER (C) ASSY	
157	4-982-854-01	HOLDER (DISC A)		171	X-4947-238-1	SLIDER (B) ASSY	
158	4-982-855-01	HOLDER (DISC B)		172	X-4947-237-1	SLIDER (A) ASSY	
159	4-982-856-01	PAD		173	4-982-880-01	SPRING (SLIDER A), TENSION	
160	4-976-458-01	HOLDER (MAGNET)		* 174	4-982-863-01	GUIDE (DISC P)	
161	X-4946-326-1	HOLDER (CLAMP) ASSY		175	3-938-588-01	SPRING, COMPRESSION	
162	4-983-777-01	SPRING (MG), TENSION		176	3-701-441-21	ø4 POLY WASHER	
163	A-4672-092-A	MAGNET ASSY					

7-5. MECHANISM SECTION-2 (CDM-40)

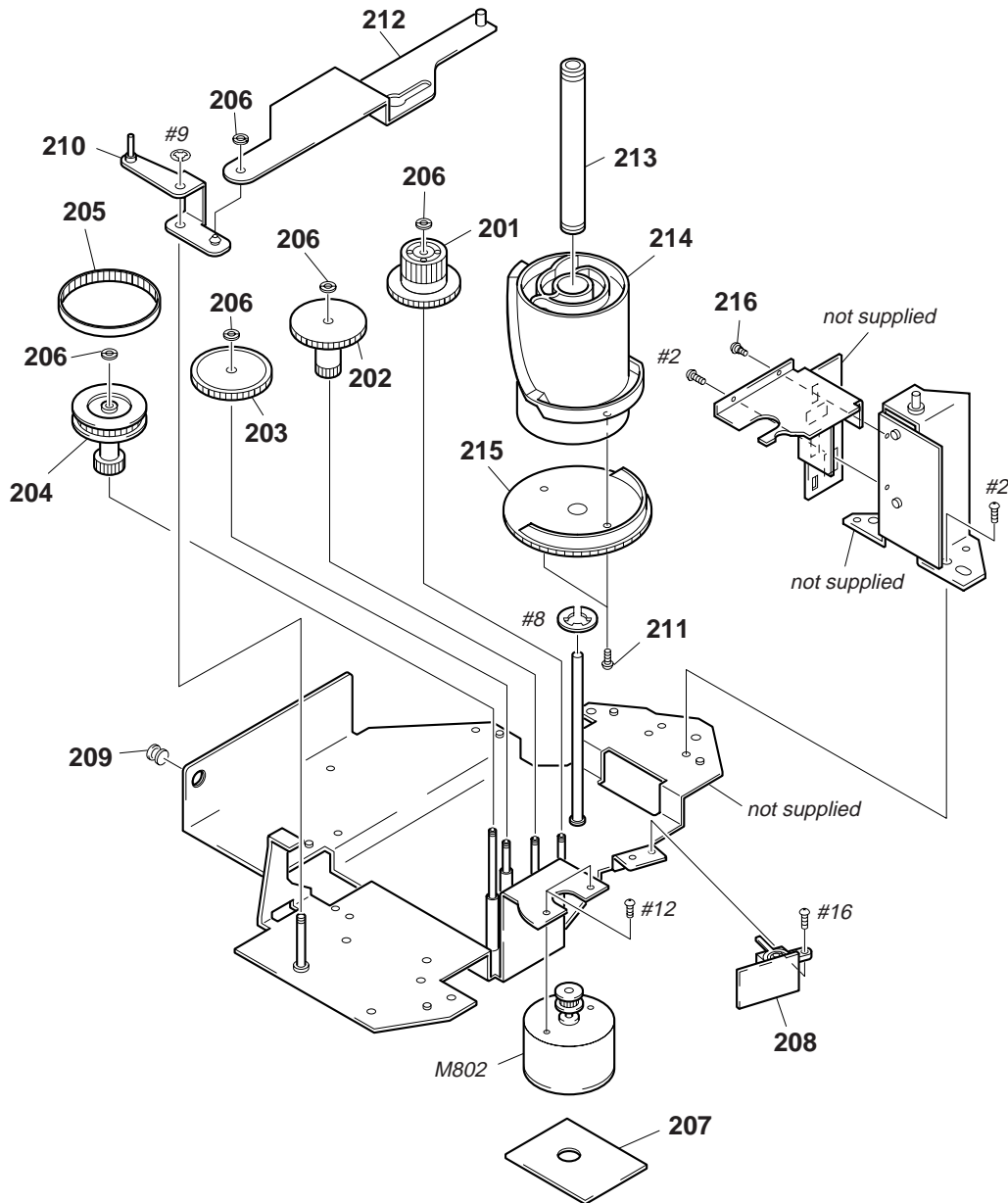

Ref. No.	Part No.	Description	Remark	Ref. No.	Part No.	Description	Remark
201	4-976-465-01	GEAR (LOADING 1)		211	4-951-291-01	SCREW	
202	4-976-466-01	GEAR (LOADING 2)		212	X-4947-234-1	SLIDER (LOCK) ASSY	
203	4-982-893-01	GEAR (CENTER 2)		213	4-982-857-01	BEARING (CAM)	
204	X-4947-607-1	GEAR (PULLEY) ASSY		214	4-982-860-01	CAM (A)	
205	4-982-867-01	BELT (TIMING)		215	4-982-861-01	CAM (B)	
206	3-325-697-21	WASHER		216	3-356-601-11	SCREW, STEP	
* 207	1-661-465-11	L.MOTOR BOARD		M802	A-4604-847-A	MOTOR ASSY, LOADING (LOADING)	
* 208	1-661-467-11	L.SW BOARD					
209	3-489-073-00	SCREW, THRUST					
210	X-4947-227-1	LEVER (STOPPER) ASSY					

7-6. BASE UNIT SECTION-1 (KSM-213 BKN/M-N)

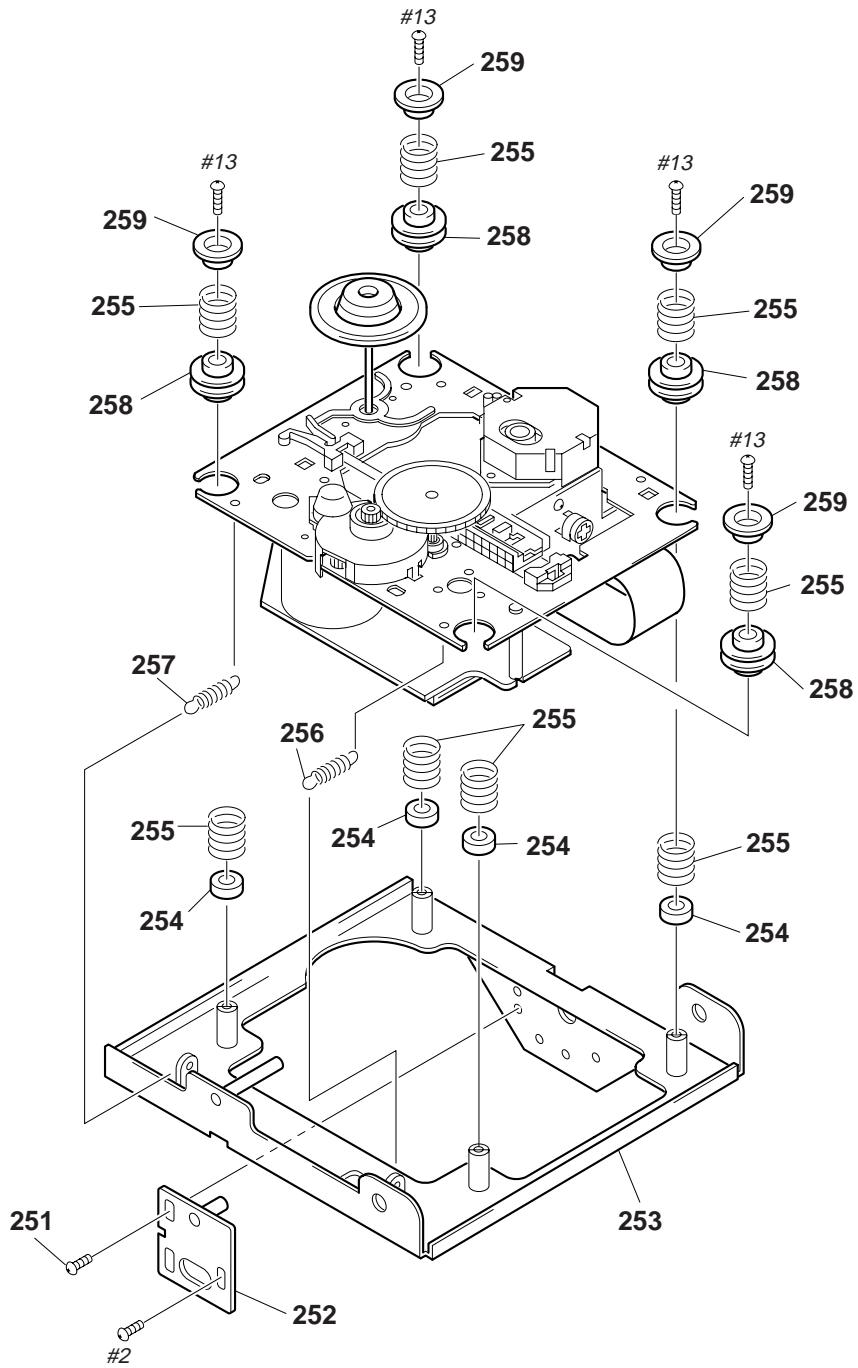

Ref. No.	Part No.	Description	Remark	Ref. No.	Part No.	Description	Remark
251	3-356-601-11	SCREW, STEP		256	4-982-872-01	SPRING (F-2), TENSION	
252	X-4947-244-1	SLIDER (BU ADJUSTMENT) ASSY		257	4-982-871-01	SPRING (F-1), TENSION	
253	X-4947-243-1	HOLDER (BU) ASSY		258	4-982-858-01	DAMPER	
254	4-982-859-01	HOLDER (DAMPER)		259	4-960-617-01	CAP (F)	
255	4-982-878-01	SPRING (F), COMPRESSION					

7-7. BASE UNIT SECTION-2 (KSM-213 BKN/M-N)

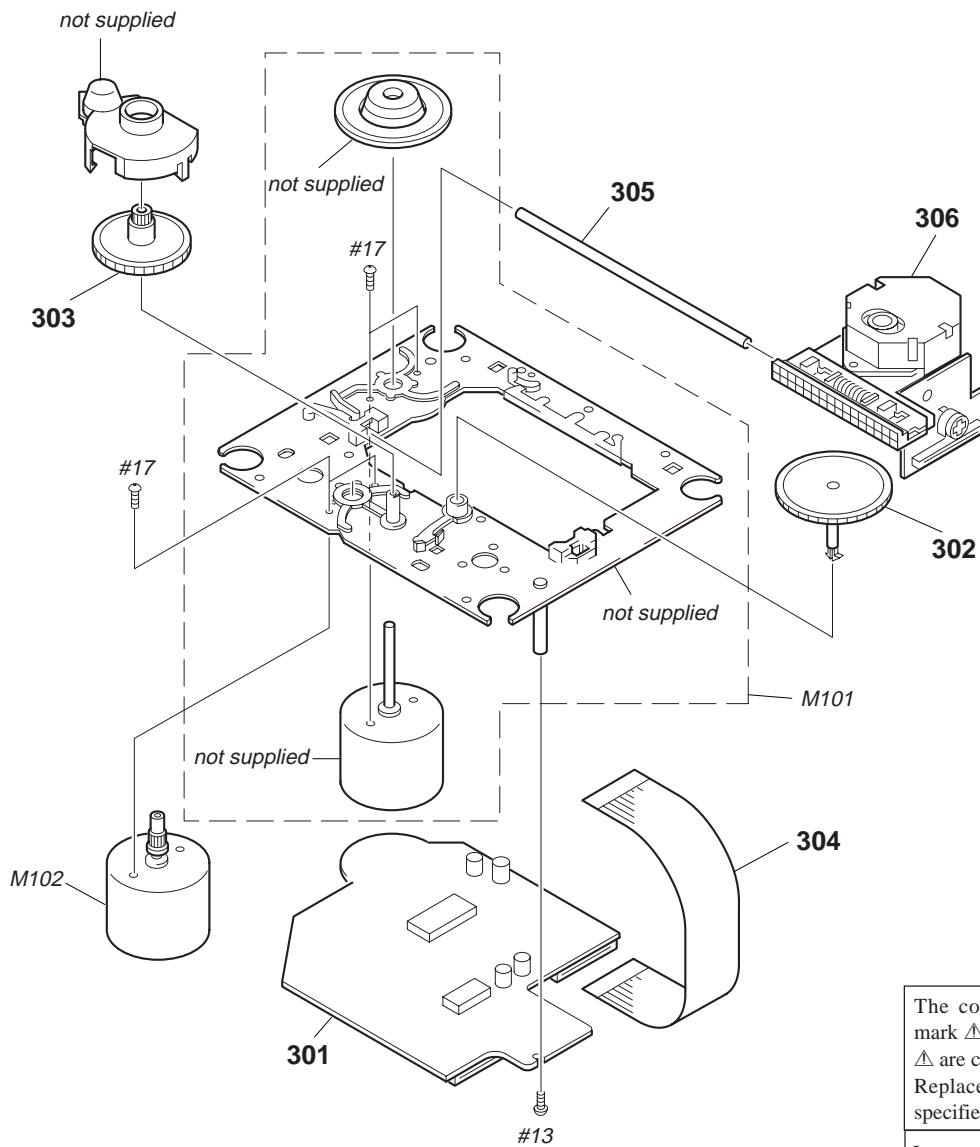

The components identified by mark \triangle or dotted line with mark \triangle are critical for safety. Replace only with part number specified.

Les composants identifiés par une marque \triangle sont critiques pour la sécurité. Ne les remplacer que par une pièce portant le numéro spécifié.

Ref. No.	Part No.	Description	Remark	Ref. No.	Part No.	Description	Remark
* 301	A-4699-163-A	BD (TEXT) BOARD, COMPLETE		\triangle 306	8-848-376-01	OPTICAL PICK-UP BLOCK KSS-213B/S-N	
302	2-626-907-01	GEAR (A)(S)		M101	X-2626-234-1	T.T CHASSIS ASSY (MG)(K)(SPINDLE)	
303	2-627-003-01	GEAR (B)(RP)		M102	X-2625-769-1	MOTOR GEAR ASSY (MB)(RP)(SLED)	
304	1-769-069-11	WIRE (FLAT TYPE) (16 CORE)					
305	2-626-908-01	SHAFT, SLED					

SECTION 8 ELECTRICAL PARTS LIST

BD (TEXT)

Note:

The components identified by mark Δ or dotted line with mark Δ are critical for safety. Replace only with part number specified.

Les composants identifiés par une marque Δ sont critiques pour la sécurité. Ne les remplacer que par une pièce portant le numéro spécifié.

When indicating parts by reference number, please include the board name.

- Due to standardization, replacements in the parts list may be different from the parts specified in the diagrams or the components used on the set.
- -XX, -X mean standardized parts, so they may have some difference from the original one.
- Items marked “*” are not stocked since they are seldom required for routine service. Some delay should be anticipated when ordering these items.
- RESISTORS
All resistors are in ohms
METAL: Metal-film resistor
METAL OXIDE: Metal Oxide-film resistor
F : nonflammable
- SEMICONDUCTORS
In each case, u: μ , for example:
uA...: μ A..., uPA...: μ PA..., uPB...: μ PB...,
uPC...: μ PC..., uPD...: μ PD...
- CAPACITORS
uF : μ F
- COILS
uH : μ H
- Abbreviation
CND : Canadian model
G : German model
SP : Singapore model
AUS : Australian model

Ref. No.	Part No.	Description	Remark	Ref. No.	Part No.	Description	Remark
*	A-4699-163-A	BD (TEXT) BOARD, COMPLETE *****		IC104	8-759-428-57	IC LC89170M	
		< CAPACITOR >				< MOTOR >	
C101	1-163-005-11	CERAMIC CHIP	470PF 10% 50V	M101	X-2626-234-1	T.T CHASSIS ASSY (MG)(K)(SPINDLE)	
C102	1-163-038-91	CERAMIC CHIP	0.1uF 25V	M102	X-2625-769-1	MOTOR GEAR ASSY (MB)(RP)(SLED)	
C103	1-163-005-11	CERAMIC CHIP	470PF 10% 50V			< TRANSISTOR >	
C105	1-135-155-21	TANTALUM CHIP	4.7uF 10% 16V	Q101	8-729-010-08	TRANSISTOR MSB710-R	
C106	1-164-346-11	CERAMIC CHIP	1uF 16V			< RESISTOR >	
C107	1-164-346-11	CERAMIC CHIP	1uF 16V	R101	1-216-077-00	METAL CHIP 15K 5% 1/10W	
C108	1-163-035-00	CERAMIC CHIP	0.047uF 50V	R102	1-216-097-91	METAL GLAZE 100K 5% 1/10W	
C109	1-163-145-00	CERAMIC CHIP	0.0015uF 5% 50V	R103	1-216-077-00	METAL CHIP 15K 5% 1/10W	
C110	1-163-017-00	CERAMIC CHIP	0.0047uF 5% 50V	R104	1-216-085-00	METAL CHIP 33K 5% 1/10W	
C111	1-163-251-11	CERAMIC CHIP	100PF 5% 50V	R105	1-216-097-91	METAL GLAZE 100K 5% 1/10W	
C112	1-163-038-91	CERAMIC CHIP	0.1uF 25V	R106	1-216-061-00	METAL CHIP 3.3K 5% 1/10W	
C113	1-163-038-91	CERAMIC CHIP	0.1uF 25V	R107	1-216-061-00	METAL CHIP 3.3K 5% 1/10W	
C114	1-163-038-91	CERAMIC CHIP	0.1uF 25V	R108	1-216-073-00	METAL CHIP 10K 5% 1/10W	
C115	1-126-607-11	ELECT CHIP	47uF 20% 4V	R109	1-216-121-91	METAL GLAZE 1M 5% 1/10W	
C116	1-126-607-11	ELECT CHIP	47uF 20% 4V	R110	1-216-025-91	METAL GLAZE 100 5% 1/10W	
C117	1-126-209-11	ELECT	100uF 20% 4V	R112	1-216-049-91	METAL GLAZE 1K 5% 1/10W	
C118	1-163-275-11	CERAMIC CHIP	0.001uF 5% 50V	R123	1-216-073-00	METAL CHIP 10K 5% 1/10W	
C119	1-163-231-11	CERAMIC CHIP	15PF 5% 50V	R124	1-216-097-91	METAL GLAZE 100K 5% 1/10W	
C120	1-124-778-00	ELECT CHIP	22uF 20% 6.3V	R125	1-216-049-91	METAL GLAZE 1K 5% 1/10W	
C123	1-164-232-11	CERAMIC CHIP	0.01uF 50V	R126	1-216-049-91	METAL GLAZE 1K 5% 1/10W	
C124	1-164-005-11	CERAMIC CHIP	0.47uF 25V	R127	1-216-049-91	METAL GLAZE 1K 5% 1/10W	
C140	1-163-038-91	CERAMIC CHIP	0.1uF 25V	R131	1-216-037-00	METAL CHIP 330 5% 1/10W	
C141	1-163-038-91	CERAMIC CHIP	0.1uF 25V	R135	1-216-295-91	CONDUCTOR, CHIP(2012)	
C151	1-163-237-11	CERAMIC CHIP	27PF 5% 50V	R136	1-216-295-91	CONDUCTOR, CHIP(2012)	
C153	1-163-038-91	CERAMIC CHIP	0.1uF 25V	R137	1-216-295-91	CONDUCTOR, CHIP(2012)	
C154	1-164-336-11	CERAMIC CHIP	0.33uF 25V	R138	1-216-295-91	CONDUCTOR, CHIP(2012)	
C156	1-163-237-11	CERAMIC CHIP	27PF 5% 50V	R141	1-216-089-91	METAL GLAZE 47K 5% 1/10W	
C157	1-163-145-00	CERAMIC CHIP	0.0015uF 5% 50V	R142	1-216-081-00	METAL CHIP 22K 5% 1/10W	
C159	1-163-019-00	CERAMIC CHIP	0.0068uF 10% 50V	R143	1-216-103-00	METAL CHIP 180K 5% 1/10W	
C161	1-163-038-91	CERAMIC CHIP	0.1uF 25V	R144	1-216-103-00	METAL CHIP 180K 5% 1/10W	
		< CONNECTOR >		R146	1-216-073-00	METAL CHIP 10K 5% 1/10W	
CN101	1-770-072-11	CONNECTOR, FFC 23P		R147	1-216-081-00	METAL CHIP 22K 5% 1/10W	
CN102	1-770-014-11	CONNECTOR, FFC/FPC 16P		R148	1-216-001-00	METAL CHIP 10 5% 1/10W	
		< IC >		R149	1-216-003-11	METAL GLAZE 12 5% 1/10W	
IC101	8-752-369-78	IC CXD2545Q		R158	1-216-111-91	METAL GLAZE 390K 5% 1/10W	
IC102	8-759-176-09	IC BA6392FP		R159	1-216-101-00	METAL CHIP 150K 5% 1/10W	
IC103	8-752-072-45	IC CXA1821M-T6		R160	1-216-295-91	CONDUCTOR, CHIP(2012)	

BD (TEXT)	DISP	DOOR SW	ILLUMINATION
------------------	-------------	----------------	---------------------

Ref. No.	Part No.	Description	Remark
R161	1-216-308-00	METAL CHIP	4.7 5% 1/10W
R162	1-216-101-00	METAL CHIP	150K 5% 1/10W
< SWITCH >			
S101	1-572-085-11	SWITCH, LEAF (LIMIT)	

*	A-4699-047-A	DISP BOARD, COMPLETE	*****
*	4-982-811-01	HOLDER (FL)	
*	4-982-812-01	HOLDER (LED)	
< CAPACITOR >			
C701	1-162-294-31	CERAMIC	0.001uF 10% 50V
C703	1-162-306-11	CERAMIC	0.01uF 30% 16V
C704	1-162-282-31	CERAMIC	100PF 10% 50V
C705	1-164-159-11	CERAMIC	0.1uF 50V
C706	1-124-584-00	ELECT	100uF 20% 10V
C707	1-162-288-31	CERAMIC	330PF 10% 50V
C708	1-162-288-31	CERAMIC	330PF 10% 50V
C709	1-162-288-31	CERAMIC	330PF 10% 50V
C710	1-162-288-31	CERAMIC	330PF 10% 50V
< DIODE >			
D701	8-719-301-52	DIODE SEL2810A-C (GROUP 1)	
D702	8-719-301-52	DIODE SEL2810A-C (GROUP 2)	
D703	8-719-301-52	DIODE SEL2810A-C (GROUP 3)	
D704	8-719-301-52	DIODE SEL2810A-C (GROUP 4)	
D705	8-719-301-52	DIODE SEL2810A-C (GROUP 5)	
D706	8-719-301-52	DIODE SEL2810A-C (GROUP 6)	
D707	8-719-301-52	DIODE SEL2810A-C (GROUP 7)	
D708	8-719-301-52	DIODE SEL2810A-C (GROUP 8)	
D709	8-719-046-44	DIODE SEL5221S (POWER)	
< FLUORESCENT INDICATOR >			
FL701	1-517-564-11	INDICATOR TUBE, FLUORESCENT	
< IC >			
IC701	8-749-012-65	IC M66004M5FP	
IC702	8-759-183-47	IC M66310FP	
< TRANSISTOR >			
Q701	8-729-900-80	TRANSISTOR DTC114ES	
< RESISTOR >			
R701	1-249-429-11	CARBON	10K 5% 1/4W
R702	1-249-417-11	CARBON	1K 5% 1/4W F
R703	1-249-409-11	CARBON	220 5% 1/4W F
R704	1-249-409-11	CARBON	220 5% 1/4W F
R705	1-249-409-11	CARBON	220 5% 1/4W F

Ref. No.	Part No.	Description	Remark
R706	1-249-434-11	CARBON	27K 5% 1/4W
R710	1-249-415-11	CARBON	680 5% 1/4W F
R711	1-249-417-11	CARBON	1K 5% 1/4W F
R712	1-249-419-11	CARBON	1.5K 5% 1/4W F
R713	1-249-421-11	CARBON	2.2K 5% 1/4W F
R714	1-247-843-11	CARBON	3.3K 5% 1/4W
R715	1-249-427-11	CARBON	6.8K 5% 1/4W F
R716	1-249-431-11	CARBON	15K 5% 1/4W
R717	1-249-415-11	CARBON	680 5% 1/4W F
R718	1-249-417-11	CARBON	1K 5% 1/4W F
R719	1-249-419-11	CARBON	1.5K 5% 1/4W F
R720	1-249-421-11	CARBON	2.2K 5% 1/4W F
R721	1-247-843-11	CARBON	3.3K 5% 1/4W
R722	1-249-427-11	CARBON	6.8K 5% 1/4W F
R723	1-249-431-11	CARBON	15K 5% 1/4W
R724	1-249-409-11	CARBON	220 5% 1/4W F
R725	1-249-409-11	CARBON	220 5% 1/4W F
R726	1-249-413-11	CARBON	470 5% 1/4W F
R727	1-249-417-11	CARBON	1K 5% 1/4W F
< SWITCH >			
S701	1-570-157-51	SWITCH, SLIDE (TIMER)	
S702	1-572-184-11	SWITCH, TACTILE (REPEAT)	
S703	1-572-184-11	SWITCH, TACTILE (PROGRAM)	
S704	1-572-184-11	SWITCH, TACTILE (SHUFFLE)	
S705	1-572-184-11	SWITCH, TACTILE (CONTINUE)	
S706	1-572-184-11	SWITCH, TACTILE (DISPLAY)	
S707	1-572-184-11	SWITCH, TACTILE (GROUP 7)	
S708	1-572-184-11	SWITCH, TACTILE (GROUP 8)	
S709	1-572-184-11	SWITCH, TACTILE (POWER)	
S710	1-572-184-11	SWITCH, TACTILE (GROUP 4)	
S711	1-572-184-11	SWITCH, TACTILE (GROUP 3)	
S712	1-572-184-11	SWITCH, TACTILE (GROUP 2)	
S713	1-572-184-11	SWITCH, TACTILE (GROUP 1)	
S714	1-572-184-11	SWITCH, TACTILE (GROUP 6)	
S715	1-572-184-11	SWITCH, TACTILE (GROUP 5)	

*	1-661-464-11	DOOR SW BOARD	*****
< SWITCH >			
S802	1-762-386-11	SWITCH, PUSH (OPEN)	

*	1-661-471-11	ILLUMINATION BOARD	*****
< CONNECTOR >			
CN810	1-506-481-11	PIN, CONNECTOR 2P	

ILLUMINATION

JACK

JOG

Ref. No.	Part No.	Description	Remark
		< DIODE >	
D802	8-719-059-65	DIODE HLMF-KL05 (INSIDE ILLUMINATION)	
D803	8-719-059-65	DIODE HLMF-KL05 (INSIDE ILLUMINATION)	
D804	8-719-059-65	DIODE HLMF-KL05 (INSIDE ILLUMINATION)	
		< RESISTOR >	
R805	1-249-407-11	CARBON 150 5% 1/4W F	
R806	1-249-407-11	CARBON 150 5% 1/4W F	
R807	1-249-407-11	CARBON 150 5% 1/4W F	

*	1-661-459-11	JACK BOARD *****	
*	4-962-200-01	PLATE (TR), GROUND	
		< CAPACITOR >	
C113	1-162-290-31	CERAMIC 470PF 10% 50V	
C213	1-162-290-31	CERAMIC 470PF 10% 50V	
C501	1-161-494-00	CERAMIC 0.022uF 25V	
C504	1-164-159-11	CERAMIC 0.1uF 50V	
C505	1-126-052-11	ELECT 100uF 20% 50V	
C506	1-162-282-31	CERAMIC 100PF 10% 50V	
C508	1-161-494-00	CERAMIC 0.022uF 30% 25V	
C511	1-164-159-11	CERAMIC 0.1uF 50V	(EXCEPT US, CND, E)
		< CONNECTOR >	
CN501	1-770-724-11	CONNECTOR, BOARD TO BOARD 9P	
CN502	1-770-724-11	CONNECTOR, BOARD TO BOARD 9P	
CN503	1-580-230-11	PIN, CONNECTOR (PC BOARD) 2P	
* CN504	1-568-951-11	PIN, CONNECTOR 2P	
		< DIODE >	
D501	8-719-987-63	DIODE 1N4148M	
		< IC >	
IC502	8-749-921-12	IC GP1F32T (OPTICAL DIGITAL OUT)	
		< JACK >	
J501	1-770-719-11	JACK, PIN 2P (LINE OUT)	
* J502	1-764-188-11	JACK (SMALL TYPE)(DIA. 3.5)(CONTROL A1)	
* J503	1-764-188-11	JACK (SMALL TYPE)(DIA. 3.5)(CONTROL A1)	
		< COIL >	
△L501	1-421-915-11	COIL, LINE FILTER	
		< TRANSISTOR >	
Q502	8-729-620-05	TRANSISTOR 2SC2603-EF	

Ref. No.	Part No.	Description	Remark
		< RESISTOR >	
R116	1-249-409-11	CARBON 220 5% 1/4W F	
R216	1-249-409-11	CARBON 220 5% 1/4W F	
R502	1-249-429-11	CARBON 10K 5% 1/4W	
R504	1-249-425-11	CARBON 4.7K 5% 1/4W F	
R505	1-249-429-11	CARBON 10K 5% 1/4W	
R506	1-249-393-11	CARBON 10 5% 1/4W F	
		< SWITCH >	
S501	1-762-151-11	SWITCH, SLIDE (COMMAND MODE)	
△S502	1-572-675-11	SWITCH, POWER VOLTAGE CHANGE (VOLTAGE SELECTOR)(E)	
		< TRANSFORMER >	
△T501	1-429-666-11	TRANSFORMER, POWER (US,CND)	
△T501	1-429-667-11	TRANSFORMER, POWER (AEP,G,AUS,SP)	
△T501	1-429-669-11	TRANSFORMER, POWER (E)	

*	A-4699-046-A	JOG BOARD, COMPLETE *****	
		< CAPACITOR >	
C601	1-124-584-00	ELECT 100uF 20% 10V	
		< CONNECTOR >	
* CN601	1-568-862-11	SOCKET, CONNECTOR 19P	
		< DIODE >	
D601	8-719-301-49	DIODE SEL2810A-CD (■)	
D602	8-719-303-02	DIODE SEL2510C-D (▷)	
		< IC >	
IC601	8-759-373-49	IC NJL54H400	
		< TRANSISTOR >	
Q601	8-729-900-89	TRANSISTOR DTC144ES	
		< RESISTOR >	
R601	1-249-415-11	CARBON 680 5% 1/4W F	
R602	1-249-417-11	CARBON 1K 5% 1/4W F	
R603	1-249-419-11	CARBON 1.5K 5% 1/4W F	
R604	1-249-421-11	CARBON 2.2K 5% 1/4W F	
R605	1-247-843-11	CARBON 3.3K 5% 1/4W	
R606	1-249-427-11	CARBON 6.8K 5% 1/4W F	
R607	1-249-431-11	CARBON 15K 5% 1/4W	
R608	1-249-437-11	CARBON 47K 5% 1/4W	
R609	1-249-415-11	CARBON 680 5% 1/4W	
R610	1-249-407-11	CARBON 150 5% 1/4W	
R611	1-247-807-31	CARBON 100 5% 1/4W	

The components identified by mark △ or dotted line with mark △ are critical for safety. Replace only with part number specified.	Les composants identifiés par une marque △ sont critiques pour la sécurité. Ne les remplacer que par une pièce portant le numéro spécifié.
--	--

JOG	L.MOTOR	L.SW	LUMINOUS	MAIN
------------	----------------	-------------	-----------------	-------------

Ref. No.	Part No.	Description	Remark
R612	1-247-807-31	CARBON	100 5% 1/4W
		< JOG SWITCH >	
RE601	1-762-717-11	SWITCH, JOG (DISC/CHARACTER)	
		< SWITCH >	
S601	1-572-184-11	SWITCH, TACTILE (■)	
S602	1-572-184-11	SWITCH, TACTILE (■)	
S603	1-572-184-11	SWITCH, TACTILE (▷)	
S604	1-572-184-11	SWITCH, TACTILE (◀)	
S605	1-572-184-11	SWITCH, TACTILE (MEMO SEARCH)	
S606	1-572-184-11	SWITCH, TACTILE (INPUT)	
S607	1-572-184-11	SWITCH, TACTILE (▷)	
S608	1-572-184-11	SWITCH, TACTILE (CHECK)	
S609	1-572-184-11	SWITCH, TACTILE (CLEAR)	
S610	1-572-184-11	SWITCH, TACTILE (ENTER)	

*	1-661-465-11	L.MOTOR BOARD	

		< MOTOR >	
M802	A-4604-847-A	MOTOR ASSY, LOADING (LOADING)	

*	1-661-467-11	L.SW BOARD	

		< SWITCH >	
S801	1-571-300-21	SWITCH, ROTARY (LOADING DET)	

*	1-661-468-11	LUMINOUS BOARD	

*	4-976-473-01	HOLDER (LED-S)	
		< DIODE >	
D801	8-719-055-84	DIODE GL-528VS1	

*	A-4699-040-A	MAIN BOARD, COMPLETE (US,CND)	

*	A-4699-041-A	MAIN BOARD, COMPLETE (AEP,G,E,AUS,SP)	

	7-685-871-01	SCREW +BVTT 3X6 (S)	
		< CAPACITOR >	
C102	1-162-282-31	CERAMIC	100PF 10% 50V

Ref. No.	Part No.	Description	Remark
C103	1-162-215-31	CERAMIC	47PF 5% 50V
C104	1-162-215-31	CERAMIC	47PF 5% 50V
C106	1-130-472-00	MYLAR	0.0012uF 5% 50V
C107	1-106-359-00	MYLAR	4700PF 5% 200V
C108	1-126-052-11	ELECT	100uF 20% 10V
C202	1-162-282-31	CERAMIC	100PF 10% 50V
C203	1-162-215-31	CERAMIC	47PF 5% 50V
C204	1-162-215-31	CERAMIC	47PF 5% 50V
C206	1-130-472-00	MYLAR	0.0012uF 5% 50V
C207	1-106-359-00	MYLAR	4700PF 5% 200V
C208	1-126-052-11	ELECT	100uF 20% 10V
C301	1-128-489-11	ELECT	3300uF 20% 16V
C302	1-124-360-00	ELECT	1000uF 20% 16V
C303	1-128-563-11	ELECT	100uF 20% 100V
C304	1-126-851-11	ELECT	22uF 20% 35V
C305	1-126-163-11	ELECT	4.7uF 20% 50V
C306	1-126-101-11	ELECT	100uF 20% 16V
C307	1-126-163-11	ELECT	4.7uF 20% 50V
C308	1-124-472-11	ELECT	470uF 20% 10V
C309	1-126-163-11	ELECT	4.7uF 20% 50V
C310	1-126-163-11	ELECT	4.7uF 20% 50V
C311	1-124-472-11	ELECT	470uF 20% 10V
C316	1-161-494-00	CERAMIC	0.022uF 25V
C317	1-126-052-11	ELECT	100uF 20% 10V
C318	1-161-494-00	CERAMIC	0.022uF 30% 25V
C319	1-126-022-11	ELECT	47uF 20% 16V
C320	1-126-022-11	ELECT	47uF 20% 16V
C322	1-161-494-00	CERAMIC	0.022uF 30% 25V
C324	1-164-159-11	CERAMIC	0.1uF 50V
C327	1-162-211-31	CERAMIC	33PF 5% 50V
C328	1-126-052-11	ELECT	100uF 20% 10V
C331	1-126-052-11	ELECT	100uF 20% 10V
C332	1-164-159-11	CERAMIC	0.1uF 50V
C333	1-126-052-11	ELECT	100uF 20% 10V
C334	1-164-159-11	CERAMIC	0.1uF 50V
C335	1-164-159-11	CERAMIC	0.1uF 50V
C336	1-162-198-31	CERAMIC	8.2PF 10% 50V
C337	1-162-198-31	CERAMIC	8.2PF 10% 50V
C339	1-164-159-11	CERAMIC	0.1uF 50V
C340	1-126-052-11	ELECT	100uF 20% 16V
C351	1-136-165-00	FILM	0.1uF 5% 50V
C352	1-164-159-11	CERAMIC	0.1uF 50V
C361	1-136-165-00	FILM	0.1uF 5% 50V
C362	1-164-159-11	CERAMIC	0.1uF 50V
C366	1-164-159-11	CERAMIC	0.1uF 50V
C371	1-136-165-00	FILM	0.1uF 5% 50V
C401	1-110-489-11	CAPACITOR	1F 5.5V
C700	1-162-306-11	CERAMIC	0.01uF 30% 16V
C710	1-162-306-11	CERAMIC	0.01uF 30% 16V
C720	1-162-306-11	CERAMIC	0.01uF 30% 16V
< CONNECTOR >			

Ref. No.	Part No.	Description	Remark	Ref. No.	Part No.	Description	Remark
CN301	1-770-728-11	CONNECTOR, BOARD TO BOARD 9P					
CN302	1-770-728-11	CONNECTOR, BOARD TO BOARD 9P					
* CN303	1-568-839-11	SOCKET, CONNECTOR 23P					
CN304	1-506-468-11	PIN, CONNECTOR 3P					
* CN305	1-568-955-11	PIN, CONNECTOR 6P					
* CN306	1-568-951-11	PIN, CONNECTOR 2P					
CN307	1-568-802-11	SOCKET, CONNECTOR 19P					
* CN308	1-568-951-11	PIN, CONNECTOR 2P					
		< DIODE >					
D301	8-719-210-21	DIODE 11EQS04					
D302	8-719-210-21	DIODE 11EQS04					
D303	8-719-210-21	DIODE 11EQS04					
D304	8-719-210-21	DIODE 11EQS04					
D305	8-719-109-93	DIODE RD6.2ESB2					
D306	8-719-024-99	DIODE 11ES2-NTA2B					
D307	8-719-987-63	DIODE 1N4148M					
D308	8-719-987-63	DIODE 1N4148M					
D309	8-719-987-63	DIODE 1N4148M					
D310	8-719-987-63	DIODE 1N4148M					
D311	8-719-987-63	DIODE 1N4148M					
D312	8-719-109-85	DIODE RD5.1ES-B2					
D313	8-719-987-63	DIODE 1N4148M					
D315	8-719-110-72	DIODE RD30ESB2					
D316	8-719-109-84	DIODE RD5.1ES-B1					
		< IC >					
IC301	8-759-330-29	IC LA5616					
IC302	8-759-821-93	IC LA5601					
IC303	8-752-859-49	IC CXP84332-027Q					
IC304	8-759-822-38	IC LA6510					
IC305	8-759-634-51	IC M5218AP					
IC306	8-759-374-72	IC LC35256AM-10					
IC307	8-759-362-47	IC CXD8567AM					
IC308	8-759-634-51	IC M5218AP					
IC309	8-759-634-51	IC M5218AP					
		< COIL >					
L304	1-412-297-11	INDUCTOR 3.3uH					
		< TRANSISTOR >					
Q101	8-729-141-26	TRANSISTOR 2SC3622A-LK					
Q102	8-729-141-26	TRANSISTOR 2SC3622A-LK					
Q201	8-729-141-26	TRANSISTOR 2SC3622A-LK					
Q202	8-729-141-26	TRANSISTOR 2SC3622A-LK					
Q301	8-729-140-97	TRANSISTOR 2SB734-34					
Q302	8-729-119-76	TRANSISTOR 2SA1175-HFE					
Q303	8-729-900-65	TRANSISTOR DTA144ES					
Q304	8-729-900-65	TRANSISTOR DTA144ES					
Q305	8-729-900-65	TRANSISTOR DTA144ES					
Q306	8-729-119-76	TRANSISTOR 2SA1175-HFE					
Q307	8-729-900-80	TRANSISTOR DTC114ES					
		< RESISTOR >					
R101	1-249-436-11	CARBON 39K	5%	1/4W			
R102	1-249-436-11	CARBON 39K	5%	1/4W			
R103	1-249-431-11	CARBON 15K	5%	1/4W			
R104	1-249-431-11	CARBON 15K	5%	1/4W			
R105	1-249-437-11	CARBON 47K	5%	1/4W			
R106	1-249-437-11	CARBON 47K	5%	1/4W			
R108	1-249-419-11	CARBON 1.5K	5%	1/4W	F		
R109	1-249-419-11	CARBON 1.5K	5%	1/4W	F		
R110	1-249-441-11	CARBON 100K	5%	1/4W			
R111	1-249-409-11	CARBON 220	5%	1/4W	F		
R112	1-249-409-11	CARBON 220	5%	1/4W	F		
R113	1-249-393-11	CARBON 10	5%	1/4W	F		
R115	1-249-425-11	CARBON 4.7K	5%	1/4W	F		
R201	1-249-436-11	CARBON 39K	5%	1/4W			
R202	1-249-436-11	CARBON 39K	5%	1/4W			
R203	1-249-431-11	CARBON 15K	5%	1/4W			
R204	1-249-431-11	CARBON 15K	5%	1/4W			
R205	1-249-437-11	CARBON 47K	5%	1/4W			
R206	1-249-437-11	CARBON 47K	5%	1/4W			
R208	1-249-419-11	CARBON 1.5K	5%	1/4W	F		
R209	1-249-419-11	CARBON 1.5K	5%	1/4W	F		
R210	1-249-441-11	CARBON 100K	5%	1/4W			
R211	1-249-409-11	CARBON 220	5%	1/4W	F		
R212	1-249-409-11	CARBON 220	5%	1/4W	F		
R213	1-249-393-11	CARBON 10	5%	1/4W	F		
R215	1-249-425-11	CARBON 4.7K	5%	1/4W	F		
R301	1-249-435-11	CARBON 33K	5%	1/4W			
R302	1-249-425-11	CARBON 4.7K	5%	1/4W	F		
R303	1-249-429-11	CARBON 10K	5%	1/4W			
R304	1-249-438-11	CARBON 56K	5%	1/4W			
R305	1-249-403-11	CARBON 68	5%	1/4W	F		
R306	1-247-739-11	CARBON 100	5%	1/2W	F		
R307	1-247-739-11	CARBON 100	5%	1/2W	F		
R308	1-249-435-11	CARBON 33K	5%	1/4W			
R309	1-249-429-11	CARBON 10K	5%	1/4W			
R310	1-249-425-11	CARBON 4.7K	5%	1/4W	F		
R311	1-247-843-11	CARBON 3.3K	5%	1/4W			
R312	1-249-429-11	CARBON 10K	5%	1/4W			
R313	1-249-429-11	CARBON 10K	5%	1/4W			
R314	1-249-429-11	CARBON 10K	5%	1/4W			
R315	1-249-403-11	CARBON 68	5%	1/4W	F		
R316	1-249-429-11	CARBON 10K	5%	1/4W			
R317	1-249-429-11	CARBON 10K	5%	1/4W			
R318	1-249-429-11	CARBON 10K	5%	1/4W			
R319	1-249-429-11	CARBON 10K	5%	1/4W			
R320	1-249-429-11	CARBON 10K	5%	1/4W			
R321	1-249-417-11	CARBON 1K	5%	1/4W	F		
R322	1-249-417-11	CARBON 1K	5%	1/4W	F		
R323	1-249-417-11	CARBON 1K	5%	1/4W	F		
R324	1-249-411-11	CARBON 330	5%	1/4W			

MAIN	RAY-CATCHER	T.MOTOR	T.SENS
-------------	--------------------	----------------	---------------

Ref. No.	Part No.	Description	Remark
R325	1-249-424-11	CARBON 3.9K 5%	1/4W F
R326	1-247-739-11	CARBON 100 5%	1/2W F
R327	1-249-411-11	CARBON 330 5%	1/4W
R329	1-249-441-11	CARBON 100K 5%	1/4W
R330	1-249-441-11	CARBON 100K 5%	1/4W
R331	1-249-425-11	CARBON 4.7K 5%	1/4W F
R332	1-249-441-11	CARBON 100K 5%	1/4W
R333	1-249-425-11	CARBON 4.7K 5%	1/4W F
R334	1-249-425-11	CARBON 4.7K 5%	1/4W F
R335	1-249-429-11	CARBON 10K 5%	1/4W
R336	1-249-429-11	CARBON 10K 5%	1/4W
R337	1-249-421-11	CARBON 2.2K 5%	1/4W F
R338	1-249-417-11	CARBON 1K 5%	1/4W F
R339	1-249-417-11	CARBON 1K 5%	1/4W F
R340	1-249-417-11	CARBON 1K 5%	1/4W F
R342	1-249-429-11	CARBON 10K 5%	1/4W
R343	1-249-429-11	CARBON 10K 5%	1/4W
R344	1-247-739-11	CARBON 100 5%	1/2W F
R351	1-249-441-11	CARBON 100K 5%	1/4W
R352	1-249-441-11	CARBON 100K 5%	1/4W
R353	1-247-860-11	CARBON 16K 5%	1/4W
R354	1-249-431-11	CARBON 15K 5%	1/4W
R355	1-249-382-11	CARBON 1.2 5%	1/6W F
R356	1-249-382-11	CARBON 1.2 5%	1/6W F
R357	1-247-883-00	CARBON 150K 5%	1/4W
R358	1-249-393-11	CARBON 10 5%	1/4W F
R361	1-247-885-00	CARBON 180K 5%	1/4W
R362	1-247-885-00	CARBON 180K 5%	1/4W
R363	1-247-860-11	CARBON 16K 5%	1/4W
R364	1-249-431-11	CARBON 15K 5%	1/4W
R365	1-249-382-11	CARBON 1.2 5%	1/6W F
R366	1-249-382-11	CARBON 1.2 5%	1/6W F
R367	1-247-883-00	CARBON 150K 5%	1/4W
R368	1-249-393-11	CARBON 10 5%	1/4W F
R373	1-249-427-11	CARBON 6.8K 5%	1/4W F
R374	1-247-843-11	CARBON 3.3K 5%	1/4W
R375	1-249-439-11	CARBON 68K 5%	1/4W
R376	1-249-427-11	CARBON 6.8K 5%	1/4W F
R377	1-249-427-11	CARBON 6.8K 5%	1/4W F
R378	1-249-417-11	CARBON 1K 5%	1/4W F
R385	1-249-429-11	CARBON 10K 5%	1/4W
R700	1-249-427-11	CARBON 6.8K 5%	1/4W F
R710	1-249-427-11	CARBON 6.8K 5%	1/4W F
R720	1-249-427-11	CARBON 6.8K 5%	1/4W F
< VIBRATOR >			
X301	1-579-175-11	VIBRATOR, CERAMIC (10MHz)	
X302	1-767-155-11	VIBRATOR, CRYSTAL (33.8688MHz)	

Ref. No.	Part No.	Description	Remark
*	1-661-469-11	RAY-CATCHER BOARD *****	
	4-985-300-01	HOLDER (P-T) < TRANSISTOR >	
Q801	8-729-926-31	PHOTO TRANSISTOR PT483F1S	

*	1-661-466-11	T.MOTOR BOARD *****	
		< MOTOR >	
M801	A-4604-847-A	MOTOR ASSY, LOADING (TABLE)	

*	1-661-470-11	T.SENS BOARD *****	
		< CONNECTOR >	
CN802	1-506-481-11	PIN, CONNECTOR 2P	
CN803	1-506-481-11	PIN, CONNECTOR 2P	
		< IC >	
IC801	8-749-924-18	IC PHOTO INTERRUPTER RPI-1391	
IC802	8-749-924-18	IC PHOTO INTERRUPTER RPI-1391	
IC803	8-749-924-18	IC PHOTO INTERRUPTER RPI-1391	
		< RESISTOR >	
R801	1-249-416-11	CARBON 820 5%	1/4W F
R802	1-249-416-11	CARBON 820 5%	1/4W F
R803	1-249-416-11	CARBON 820 5%	1/4W F
R804	1-249-415-11	CARBON 680 5%	1/4W F

Ref. No.	Part No.	Description	Remark
		MISCELLANEOUS *****	
4	1-773-183-11	WIRE (FLAT TYPE) (23 CORE)	
5	1-777-345-11	WIRE (FLAT TYPE) (19 CORE)	
△ 12	1-569-007-11	ADAPTOR, CONVERSION 2P (E)	
304	1-769-069-11	WIRE (FLAT TYPE) (16 CORE)	
△ 306	8-848-376-01	OPTICAL PICK-UP BLOCK KSS-213B/S-N	
△ CNP901	1-575-042-21	CORD, POWER (US,CND)	
△ CNP901	1-575-651-21	CORD, POWER (AEP,G,SP)	
△ CNP901	1-696-027-11	CORD, POWER (E)	
△ CNP901	1-696-845-11	CORD, POWER (AUS)	
FL701	1-517-564-11	INDICATOR TUBE, FLUORESCENT	
M101	X-2626-234-1	T.T CHASSIS ASSY (MG)(K)(SPINDLE)	
M102	X-2625-769-1	MOTOR GEAR ASSY (MB)(RP)(SLED)	
M801	A-4604-847-A	MOTOR ASSY, LOADING (TABLE)	
M802	A-4604-847-A	MOTOR ASSY, LOADING (LOADING)	
△ T501	1-429-666-11	TRANSFORMER, POWER (US,CND)	
△ T501	1-429-667-11	TRANSFORMER, POWER (AEP,G,AUS,SP)	
△ T501	1-429-669-11	TRANSFORMER, POWER (E)	

ACCESSORIES & PACKING MATERIALS

1-473-801-11	REMOTE COMMANDER (RM-DX250)
1-558-271-11	CORD, CONNECTION (AUDIO 108cm)
1-777-172-11	CORD, CONNECTION (CONTROL-A1)(CND)
3-707-584-21	COVER, BATTERY (RM-DX250)
3-810-765-11	MANUAL,COMMONNESS INSTRUCTION (FOR CONTROL-A1)(ENGLISH) (US,AUS)
3-810-765-21	MANUAL,COMMONNESS INSTRUCTION (FOR CONTROL-A1) (ENGLISH,FRENCH,GERMAN,SPANISH,DUTCH, SWIDISH,ITALIAN,PORTUGUESE,CHINESE) (EXCEPT US,AUS)
3-856-766-11	MANUAL, INSTRUCTION (ENGLISH,FRENCH,SPANISH,SWEDISH) (EXCEPT US,AUS)
3-856-766-21	MANUAL, INSTRUCTION (ENGLISH)(US,AUS)
3-856-766-31	MANUAL, INSTRUCTION (CHINESE)(SP)
3-856-766-41	MANUAL, INSTRUCTION (GERMAN,DUTCH,ITALIAN,PORTUGUSES)(AEP,G)
4-984-086-01	BOOKLET (100)
* 4-983-803-01	CUSHION
* 4-983-811-01	INDIVIDUAL, CARTON (US,CND)
* 4-983-812-01	INDIVIDUAL, CARTON (AEP,G)
* 4-983-813-01	INDIVIDUAL, CARTON (AUS)
* 4-983-814-01	INDIVIDUAL, CARTON (SP)
* 4-986-416-01	INDIVIDUAL, CARTON (E)

Ref. No.	Part No.	Description	Remark
		***** HARDWARE LIST *****	
#1	7-685-646-79	SCREW +BVTP 3X8 TYPE2 N-S	
#2	7-685-871-01	SCREW +BVTT 3X6 (S)	
#3	7-685-647-79	SCREW +BVTP 3X10 TYPE2 N-S	
#4	7-685-534-19	SCREW +BTP 2.6X8 TYPE2 N-S	
#5	7-685-871-09	SCREW +BVTT 3X6 (S)	
#6	7-682-947-01	SCREW +PSW 3X6	
#7	7-682-548-04	SCREW +BVTT 3X8 (S)	
#8	7-624-111-04	STOP RING 7.0, TYPE -E	
#9	7-624-106-04	STOP RING 3.0, TYPE -E	
#10	7-621-772-20	SCREW +B 2X5	
#11	7-682-552-09	SCREW +B 3X16	
#12	7-621-775-00	SCREW +B 2.6X3	
#13	7-621-772-30	SCREW +B 2X6	
#15	7-624-109-04	STOP RING 5.0, TYPE -E	
#16	7-621-775-20	SCREW +B 2.6X5	
#17	7-682-255-15	SCREW +P 2X3	

The components identified by mark △ or dotted line with mark △ are critical for safety. Replace only with part number specified.	Les composants identifiés par une marque △ sont critiques pour la sécurité. Ne les remplacer que par une pièce portant le numéro spécifié.
--	--

CDP-CX250

SONY®

SERVICE MANUAL

*US Model
Canadian Model
AEP Model
E Model
Australian Model*

SUPPLEMENT-1

File this supplement with the service manual.

Subject :

- 1. CORRECTION**
- 2. CD-TEXT TEST DISC**
- 3. AGING MODE**
- 4. DISC SENSOR ADJUSTMENT**
- 5. PARTS CHANGED**
- 6. BOARD & CIRCUIT CHANGED**

(ECN-CD600998)

1. CORRECTION

• Correct your service manual as shown below.

 : indicates corrected portion.

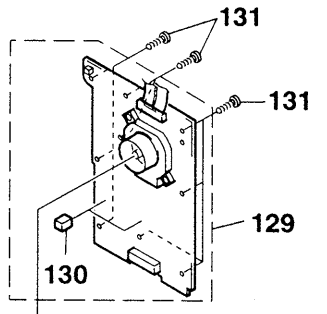
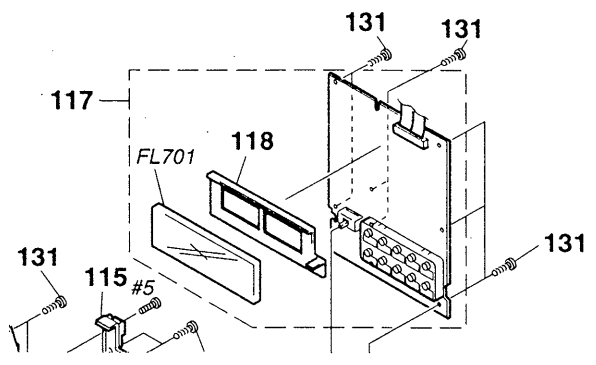
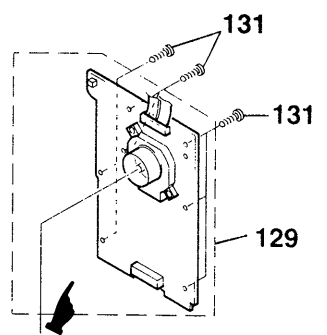
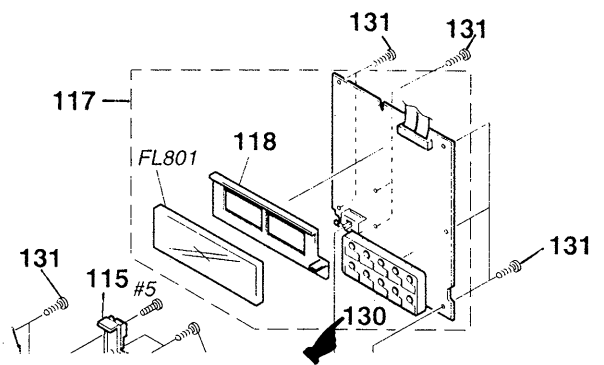

Page	INCORRECT	CORRECT
17	<p>SENSOR ALIGNMENT If the disc table swings to the left and right just before the disc is chucked, perform the following adjustment.</p>	<p>SENSOR ALIGNMENT Perform this adjustment after the "holder (disc A) adjustment". If the disc table swings to the left and right just before the disc is chucked, perform the following adjustment.</p>
56	 	 

Page	INCORRECT						CORRECT																																	
	Ref. No.	Part No.	Description				Remark	Ref. No.	Part No.	Description				Remark																										
58																																								
62	<p>*** ELECTRICAL PARTS LIST ***</p> <p>*** DISP BOARD ***</p> <table border="1"> <tr> <td>R724</td> <td>1-249-409-11</td> <td>CARBON</td> <td>220</td> <td>5%</td> <td>1/4W</td> <td></td> </tr> <tr> <td>R725</td> <td>1-249-409-11</td> <td>CARBON</td> <td>220</td> <td>5%</td> <td>1/4W</td> <td></td> </tr> </table>						R724	1-249-409-11	CARBON	220	5%	1/4W		R725	1-249-409-11	CARBON	220	5%	1/4W		<p>*** ELECTRICAL PARTS LIST ***</p> <p>*** DISP BOARD ***</p> <table border="1"> <tr> <td>R724</td> <td>1-249-411-11</td> <td>CARBON</td> <td>330</td> <td>5%</td> <td>1/4W</td> <td>F</td> </tr> <tr> <td>R725</td> <td>1-249-411-11</td> <td>CARBON</td> <td>330</td> <td>5%</td> <td>1/4W</td> <td>F</td> </tr> </table>						R724	1-249-411-11	CARBON	330	5%	1/4W	F	R725	1-249-411-11	CARBON	330	5%	1/4W	F
R724	1-249-409-11	CARBON	220	5%	1/4W																																			
R725	1-249-409-11	CARBON	220	5%	1/4W																																			
R724	1-249-411-11	CARBON	330	5%	1/4W	F																																		
R725	1-249-411-11	CARBON	330	5%	1/4W	F																																		
64	<p>*** MAIN BOARD ***</p> <hr/>						<p>*** MAIN BOARD ***</p> <table border="1"> <tr> <td>C330</td> <td>1-162-207-11</td> <td>CERAMIC</td> <td>22PF</td> <td>5%</td> <td>50V</td> <td></td> </tr> </table>						C330	1-162-207-11	CERAMIC	22PF	5%	50V																						
C330	1-162-207-11	CERAMIC	22PF	5%	50V																																			
67	<p>*** ACCESSORIES & PACKING MATERIALS ***</p> <table border="1"> <tr> <td>3-707-584-21</td> <td>COVER, BATTERY (RM-DX250)</td> <td></td> <td></td> <td></td> <td></td> <td></td> </tr> </table>						3-707-584-21	COVER, BATTERY (RM-DX250)						<p>*** ACCESSORIES & PACKING MATERIALS ***</p> <table border="1"> <tr> <td>4-981-643-01</td> <td>COVER, BATTERY (RM-DX250)</td> <td></td> <td></td> <td></td> <td></td> <td></td> </tr> </table>						4-981-643-01	COVER, BATTERY (RM-DX250)																			
3-707-584-21	COVER, BATTERY (RM-DX250)																																							
4-981-643-01	COVER, BATTERY (RM-DX250)																																							

2. CD-TEXT TEST DISC

This unit is able to display the test data (character information) written in the CD on its fluorescent indicator tube. The CD-TEXT TEST DISC (TGCS-313:J-2501-126-A) is used for checking the display. To check, perform the following procedure.

Checking Method:

1. Turn ON the power, set the disc on the disc table with the side labeled as "test disc" as the right side, close the front cover, and chuck the disc.
2. Press the  button and play back the disc.
3. The following will be displayed on the fluorescent indicator tube.
Display : 1kHz/0 dB/L&R
4. Press the  and  buttons to switch the track. The text data of each track will be displayed.
For details of the displayed contents for each track, refer to "Table 1 : CD-TEXT TEST DISC TEXT Data Contents" and "Table 2 : CD-TEXT TEST DISC Recorded Contents and Display".

Restrictions in CD-TEXT Display

In this unit, some special characters will not be displayed properly. These will be displayed as a space or a character resembling it. For details, refer to "Table 2 : CD-TEXT DISC Recorded Contents and Display".

Table 1 : CD-TEXT TEST DISC TEXT Data Contents (TRACKS No. 1 to 41:Normal Characters)

TRACK No.	Displayed Contents	TRACK No.	Displayed Contents
1	1kHz/0dB/L&R	22	1kHz/-90dB/L&R
2	20Hz/0dB/L&R	23	Infinity Zero w/o emphasis//L&R
3	40Hz/0dB/L&R	24	Infinity Zero with emphasis//L&R
4	100Hz/0dB/L&R	25	400Hz+7kHz(4:1)/0dB/L&R
5	200Hz/0dB/L&R	26	400Hz+7kHz(4:1)/-10dB/L&R
6	500Hz/0dB/L&R	27	19kHz+20kHz(1:1)/0dB/L&R
7	1kHz/0dB/L&R	28	19kHz+20kHz(1:1)/-10dB/L&R
8	5kHz/0dB/L&R	29	100Hz/0dB/L*
9	7kHz/0dB/L&R	30	1kHz/0dB/L*
10	10kHz/0dB/L&R	31	10kHz/0dB/L*
11	16kHz/0dB/L&R	32	20kHz/0dB/L*
12	18kHz/0dB/L&R	33	100Hz/0dB/R*
13	20kHz/0dB/L&R	34	1kHz/0dB/R*
14	1kHz/0dB/L&R	35	10kHz/0dB/R*
15	1kHz/-1dB/L&R	36	20kHz/0dB/R*
16	1kHz/-3dB/L&R	37	100Hz Squer Wave//L&R
17	1kHz/-6dB/L&R	38	1kHz Squer Wave//L&R
18	1kHz/-10dB/L&R	39	1kHz w/emphasis/-0.37dB/L&R
19	1kHz/-20dB/L&R	40	5kHz w/emphasis/-4.53dB/L&R
20	1kHz/-60dB/L&R	41	16kHz w/emphasis/-9.04dB/L&R
21	1kHz/-80dB/L&R		

NOTE : The contents of Track No. 1 to 41 are the same as those of the current TEST DISC-their titles are displayed.

Table 2: CD-TEXT TEST DISC Recorded Contents and Display
(In this unit, some special characters cannot be displayed. This is no a fault.)

TRACK No.	Recorded contents	Display
42	! " # \$ % & ' (21h to 27h) 1kHz 0dB L&R	← All the same
43	() * + , - . / (28h to 2Fh)	← All the same
44	0 1 2 3 4 5 6 7 (30h to 37Fh)	← All the same
45	8 9 : ; < = > ? (38h to 3Fh)	← All the same
46	@ A B C D E F G (40h to 47Fh)	← All the same
47	H I J K L M N O (48h to 4Fh)	← All the same
48	P Q R S T U V W (50h to 57Fh)	← All the same
49	X Y Z [¥] ^ _ (58h to 5Fh)	X Y Z [\] ^ _ (58....
50	` a b c d e f g (60h to 67Fh)	← All the same
51	h i j k l m n o (68h to 6Fh)	← All the same
52	p q r s t u v w (70h to 77Fh)	← All the same
53	x y z { } ~ ■ (78h to 7Fh)	x y z { } ~ ■ (78....
54	■ i ç £ ¤ ¥ ¦ § (A0h to A7h) 8859-1	(A0.... All not displayed
55	♪ © ¢ « ¬ ® ¯ (A8h to AFh)	(A8.... All not displayed
56	• ± ² ³ ´ µ ¶ • (B0h to B7h)	(B0.... All not displayed
57	† † ° » ¼ ½ ¾ ¿ (B8h to BFh)	(B8.... All not displayed
58	À Á Â Ã Ä Å Æ Ç (C0h to C7Fh)	A A A A A A C (C0.... Æ is not displayed
59	È É Ê Ë Ì Í Î (C8h to CFh)	E E E E I I I I (C8
60	Ð Ñ Ò Ó Ô Õ Ö × Ø (D0h to D7Fh)	D N O O O O O (D0.... × is not displayed
61	Ø Ù Ú Û Ü Ý Þ ß (D8h to DFh)	O U U U U Y (D8.... Þ ß are not displayed
62	à á â ã ä å æ ç (E0h to E7Fh)	a a a a a a c (E0.... æ is not displayed
63	è é ê ë ì í î ï (E8h to FFh)	e e e e i i i i (E8....
64	ð ñ ò ó ô õ ö ÷ (F0h to F7Fh)	d n o o o o o (F0.... ÷ is not displayed
65	ø ù ú û ü ý þ ÿ (F8h to FFFh)	o u u u u y y (F8.... þ is not displayed
66	No.66	← All the same
67	No.67	← All the same
to	to	to
99	No.99	← All the same

3. AGING MODE

Aging Mode

- Mode which repeatedly changes and plays back discs automatically in the unit.
 - It will repeat aging as long as no errors occur.
 - If an error occurs during aging, it will stop all servos, motors, etc. instantaneously, display the error number, and stop operations. However, the stopping conditions differ according to whether the unit is equipped with the "self-protection function during errors" described later.
- The function serves to maintain the state of the unit when errors occur.

Sequence of Aging Mode

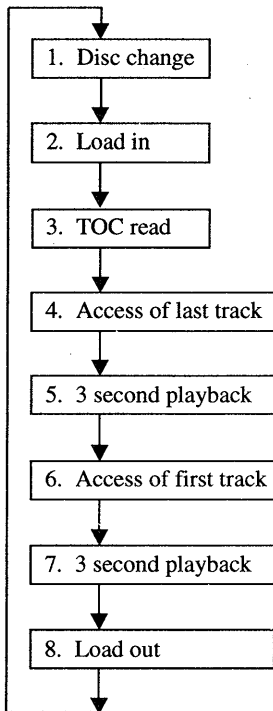

Order of Disc Change (1 cycle takes 3 minutes)

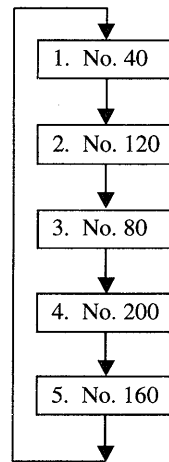

Microcomputer Version and special Functions of Aging Mode

The operations in the aging mode differ according to the version of the microcomputer used (whether it is former or new.)

The version can be differentiated as follows.

[MAIN Board] –Component Side – IC303

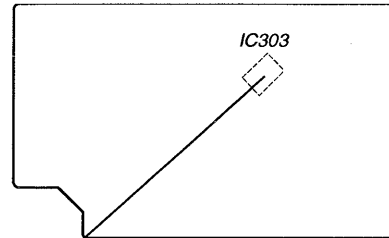

CXP84332-027Q : Former Type
 CXP84332-038Q : New Type
 CXP84332-046Q : New Type
 • or later

Special Functions in Aging Mode

	Former Type	New Type
Disc setting mode*1	None	Present
Self protection function during errors*2 (Stops immediately when errors occur)	None	Present/none (Switchable)
Aging cycle count function *3	None	Present

*1 Disc setting mode:

5 discs are set before setting the aging mode. This mode makes the setting of these discs more easy.

*2 Self protection function during errors:

Function which voluntarily corrects errors which occur during normal operations by retries.

If this function is not provided, all operations will be stopped without retiring. It is suitable for checking errors with low reproducibility.

If this function is provided, and errors can be corrected by retries, aging will be continued without stopping.

*3 Aging cycle count function:

Functions which displays the number of agings carried out on the Fluorescent indicator tube in numbers. One aging cycle consists of five discs.

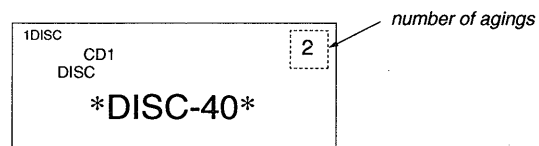

Aging Method

* The procedure differs according to the type of microcomputer used (whether it is former or new).

In the case of the new type:

1. Change the **COMMAND MODE** switch (S501) on set to **CD1**.
2. Turn ON the power of the unit. Open the front cover.
3. Press the AGING START button of the remote commander for aging mode (J-2501-123-A).
4. When the disc set mode is set, the \triangleright and \blacksquare LEDs blink.
5. Rotate the JOG dial. The slits (No. 40, 80, 120, 160, 200) for setting the discs will come forward. Insert the discs into these slits. Do not set the discs in other slits.
6. Set whether the self-protection function during errors is equipped with the unit. Press the REPEAT button. If "REPEAT" is displayed on the Fluorescent indicator tube, it means the function is provided. If "REPEAT" is not displayed, it means the function is not provided.
7. Press the \triangleright button.
8. The \triangleright LED blinks, the aging mode is set, and aging is started.
9. The aging cycle lasts 3 minutes. If errors occur during aging, the error number will be displayed on the Fluorescent indicator tube. (Refer to the following table for the details of the errors.)
10. Aging will be repeated as long as no errors occur.
11. After each aging cycle, the number displayed on the Fluorescent indicator tube will increase.
12. To end aging, press the POWER button

In the case of the Former type:

1. Change the **COMMAND MODE** switch (S501) on set to **CD1**.
2. Set the disc to No. 40, 80, 120, 160, 200. Do not set to other numbers.
3. Press the AGING START button of the remote commander for aging mode (J-2501-123-A).
4. The \triangleright LED blinks, the aging mode is set, and aging is started.
5. The aging cycle lasts 3 minutes. If errors occur during aging, the error number will be displayed on the Fluorescent indicator tube.
6. Aging will be repeated as long as no errors occur.
7. To end aging, press the POWER button.

Error Display

120 Err01

Disc number Error code

Note) The error codes for the former type are displayed in hexadecimal digits.

Refer to the conversion table.

Hexadecimal→Decimal Conversion Table

Hexa-decimal	Deci-mal	Hexa-decimal	Deci-mal	Hexa-decimal	Deci-mal	Hexa-decimal	Deci-mal
01	01	15	21	1F	31	29	41
02	02	16	22	20	32	2A	42
03	03	17	23	21	33	2B	43
04	04	18	24	22	34	2C	44
05	05	19	25	23	35	2D	45
06	06	1A	26	24	36	2E	46
		1B	27	25	37	2F	47

Error code

Code number	Name	Contents
Err 01	DISC sensor check 1	No disc in the specified slit
Err 02	DISC sensor check 2	Disc in other slits
Err 03	Table operation check 1	Table motor current over
Err 04	Table operation check 2	No table sensor input
Err 05	Loading operation check 1	Load in timeover
Err 06	Loading operation check 2	Load out timeover
Err *1	BU related check 1	Access timeover
Err *2	BU related check 2	High speed search NG
Err *3	BU related check 3	Q data read error
Err *4	BU related check 4	BU operation (from focus search to until signal can be read) timeover
Err *5	BU related check 5	GFS monitor error
Err *6	BU related check 6	Focus cannot be imposed by focus search
Err *7	BU related check 7	Auto focus bias adjustment cannot be performed

The * numbers mean the following according to the state of the unit during aging

2 : From chucking to end of TOC read

3 : From end of TOC read to end of last track playback

4 : From end of last track playback to end of first track playback

4. DISC SENSOR ADJUSTMENT

Note: The R308 mounted on the MAIN board has changed to RV301. The set which is changed into RV301 needs to adjust a disc sensor.

Disc Sensor Adjustment

Perform this adjustment after completing all adjustments of the mechanism section.

If not performed accurately, the presence of the disc may not be detected properly.

Connection 1:

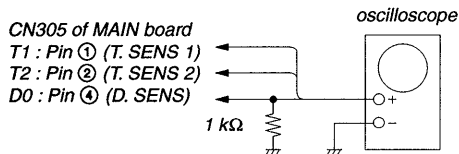

Waveform 1:

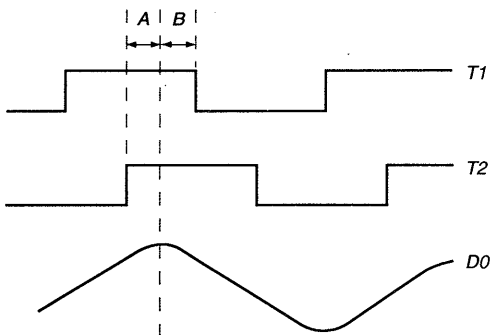

Connection 2:

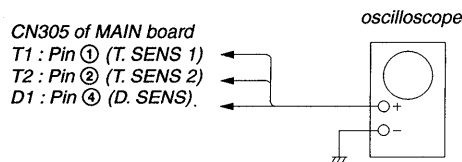

Waveform 2

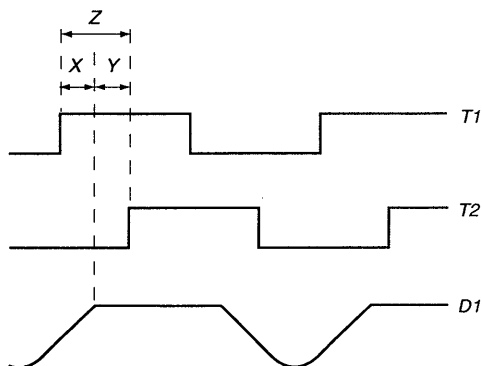

Procedure:

1. Connect the oscilloscope to Pins ①, ②, and ④ of CN305 of the MAIN board. Also connect a 1 kΩ resistor to Pin ④ at the same time. (Connection 1)
2. Disconnect the CN308 (2P) and CN306 (2P) cables of the MAIN board. Connect the cables connected to CN306 (connected to the T. MOTOR board) to CN308.

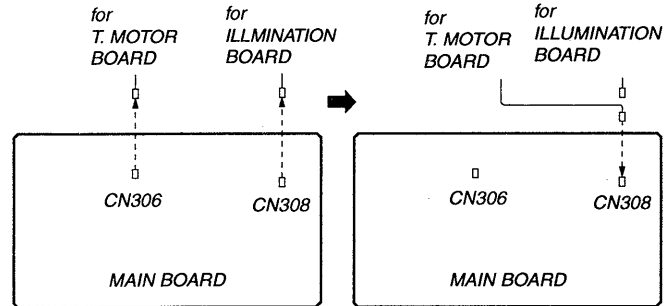

3. Open the front cover. (If closed, malfunctions by incorrect operations may result.)
4. Check that no discs are loaded in the unit, and press the POWER button to turn ON the power.
5. The rotary table will continue rotating in the clockwise direction.
6. Observe the waveform at that time on the oscilloscope.
7. Loosen the screw securing the LUMINOUS board slightly.
8. Slide the LUMINOUS board to the left and right so that the peak of the D0 waveform is at the center between the descending point of the T1 waveform and ascending point of the T2 waveform. (Waveform 1) After adjusting, apply locking compound.

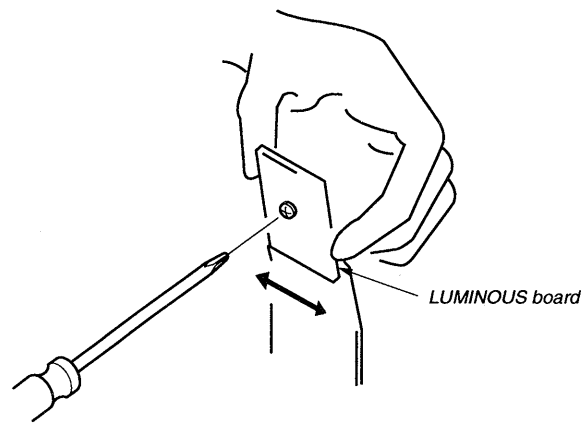

9. Disconnect the resistor connected to Pin ④ of CN305 of the MAIN board. (Connection 2)
10. Observe the waveform on the oscilloscope. (Waveform 2)
11. Adjust RV301 of the MAIN board so that the waveform on the oscilloscope satisfies the following adjustment value 1.
12. Connect the connectors disconnected in Step 2 at their original positions.
13. Close the front cover, and rotate the JOG dial in the counterclockwise direction continuously so that the rotary table rotates continuously in the counterclockwise direction.
14. Observe the waveform on the oscilloscope and confirm that it satisfies the adjustment value 2 (waveform 3). If it does not, adjust RV301 of the MAIN board.

Waveform 3:

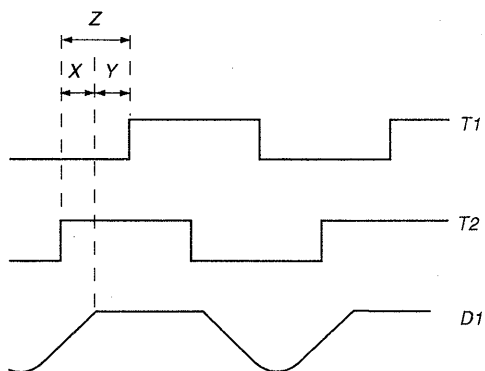

15. After the adjustment, load a disc only in slit 1, close the front cover, and press the POWER button to turn off the power. (*NOTE)
16. Press the POWER button while pressing the ENTER button to turn on the power. (*NOTE)
17. If the rotary table makes one round, and “YES” is displayed on the fluorescent indicator tube after it stops, it means that the adjustment has been performed properly. (*NOTE)

***NOTE**

The procedure of the disc sensor adjustment will be changed depending on the version of IC303 on the MAIN board. If the version of the microprocessor is a former type, the procedure 15, 16 and 17 will not be able to confirm. Only the new type of that can be confirmed.

- | | |
|---------------|-----------------|
| CXP84332-027Q |) : Former Type |
| CXP84332-038Q | |
| CXP84332-046Q | |
| CXP84332-047Q | |
| ⋮ |) : New Type |
| or later | |

Adjustment value 1:

At the shoulder part of waveform D1, T1 becomes “H” and T2 becomes “L”, and at the same time, the Y width must not be smaller than 1/4 of the Z width.

In order to satisfy this value more easily, adjust so that X=Y approximately and observe the deviation of the waveform.

Adjustment value 2:

At the shoulder part of waveform D1, T1 becomes “H” and T2 becomes “L”, and at the same time, the Y width must not be smaller than 1/4 of the Z width.

Adjustment Location:

[MAIN BOARD] — Component Side —

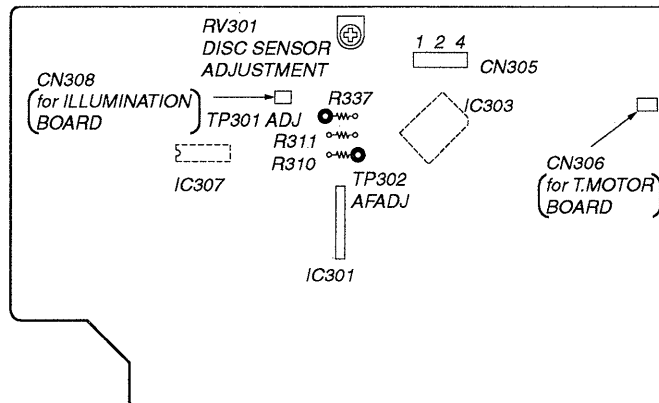

5. PARTS CHANGED

 : indicates changed portion.

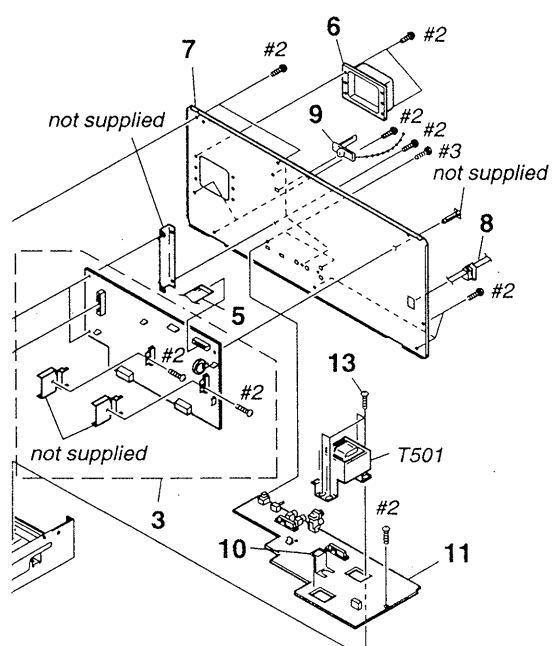
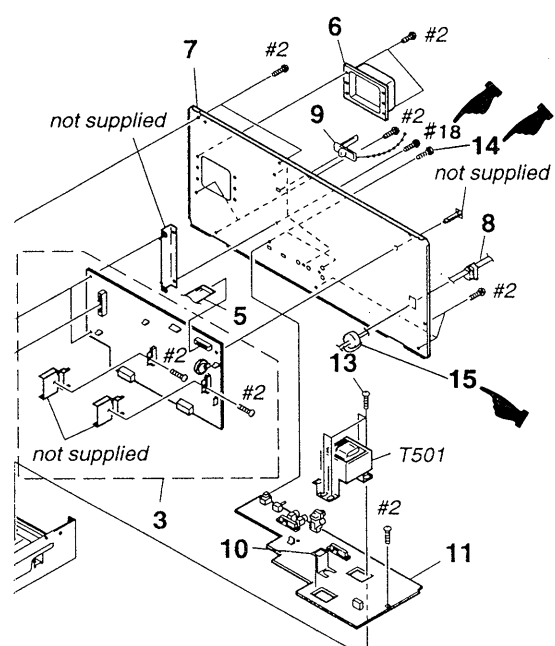
Page	FORMER				NEW			
	Ref. No.	Part No.	Description	Remark	Ref. No.	Part No.	Description	Remark
54	*** EXPLODED VIEWS ***				*** EXPLODED VIEWS ***			
	5	1-777-345-11	WIRE (FLAT TYPE) (19 CORE)		5	1-777-345-11	WIRE (FLAT TYPE) (19 CORE) (EXCEPT US, CND)	
					5	1-777-723-11	WIRE (FLAT TYPE) (19 CORE) (US, CND)	
					14	3-704-515-01	SCREW (BV/RING)	
					15	1-543-982-11	CORE, FERRITE (US, CND)	
								

• Abbreviation
CND : Canadian model

Page	FORMER				NEW			
	Ref. No.	Part No.	Description	Remark	Ref. No.	Part No.	Description	Remark
55	* 74	3-378-433-01	CUSHION, SARANET		* 74	3-378-434-01	CUSHION, SARANET	
	75	4-985-553-01	CUSHION		75	4-985-553-01	CUSHION	
					82	4-985-574-01	SPACER (ROLLER)	
					83	4-053-543-01	RIVET, NYLON	

Page	FORMER				NEW			
	Ref. No.	Part No.	Description	Remark	Ref. No.	Part No.	Description	Remark
56	* 129	A-4699-046-A	JOG BOARD, COMPLETE		* 129	A-4699-046-A	JOG BOARD, COMPLETE (EXCEPT AEP, G)	
					* 129	A-4699-508-A	JOG BOARD, COMPLETE (AEP, G)	
					132	4-985-553-21	CUSHION	
57	157	4-982-854-01	HOLDER (DISC A)		157	4-988-143-01	HOLDER (DISC A2)	not used
	176	3-701-441-21	ø4 POLY WASHER					
67	*** HEADWARE LIST ***				*** HEADWARE LIST ***			
					#18	7-682-547-04	SCREW +BV3X6, S TIGHT	

• Abbreviation
G : German model

6. BOARD & CIRCUIT CHANGED

— BD, DISP SECTION —

See page 37. Location A—H, 12—17

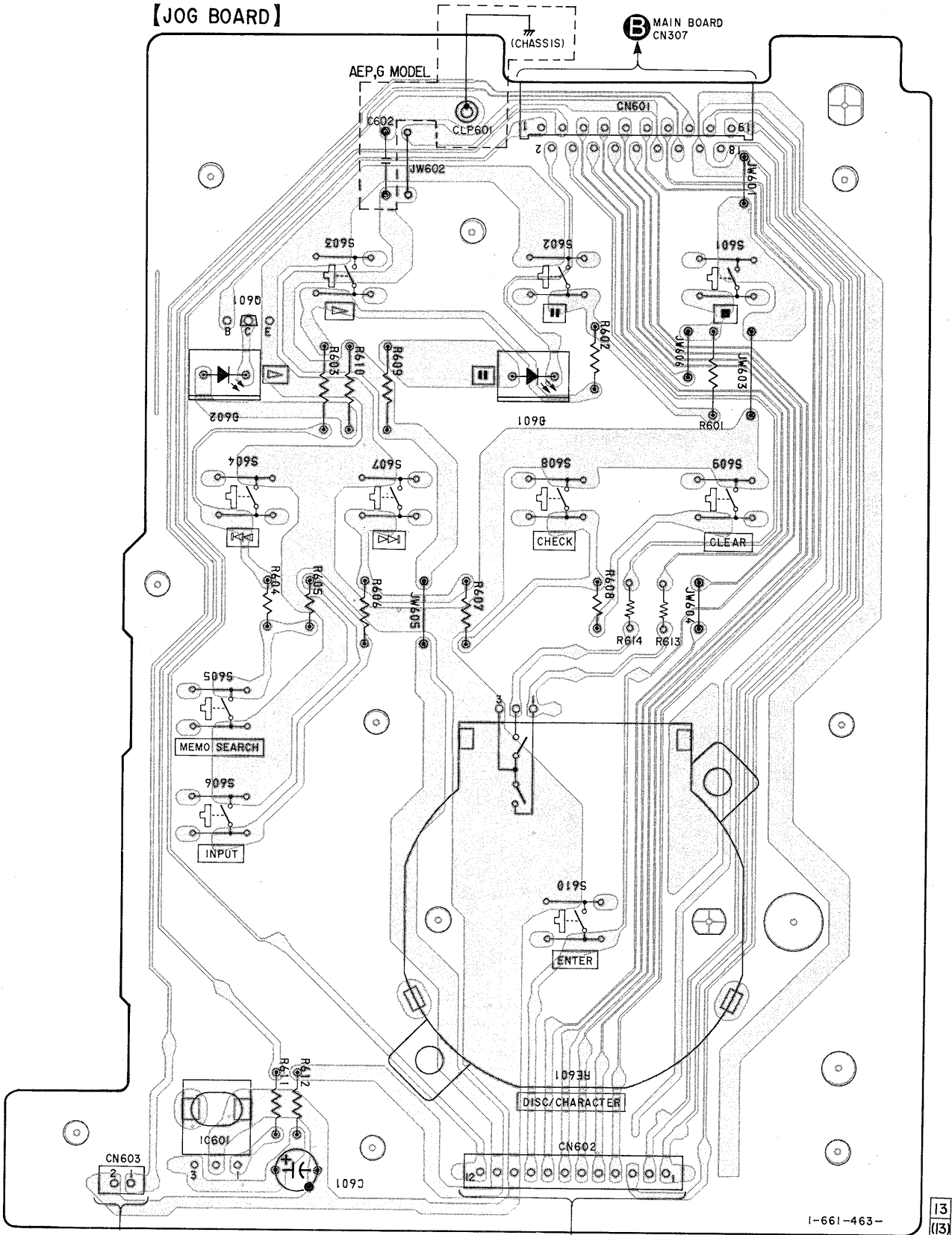

— BD, DISP SECTION —

See page 40, 41. Location D—H, 15—21

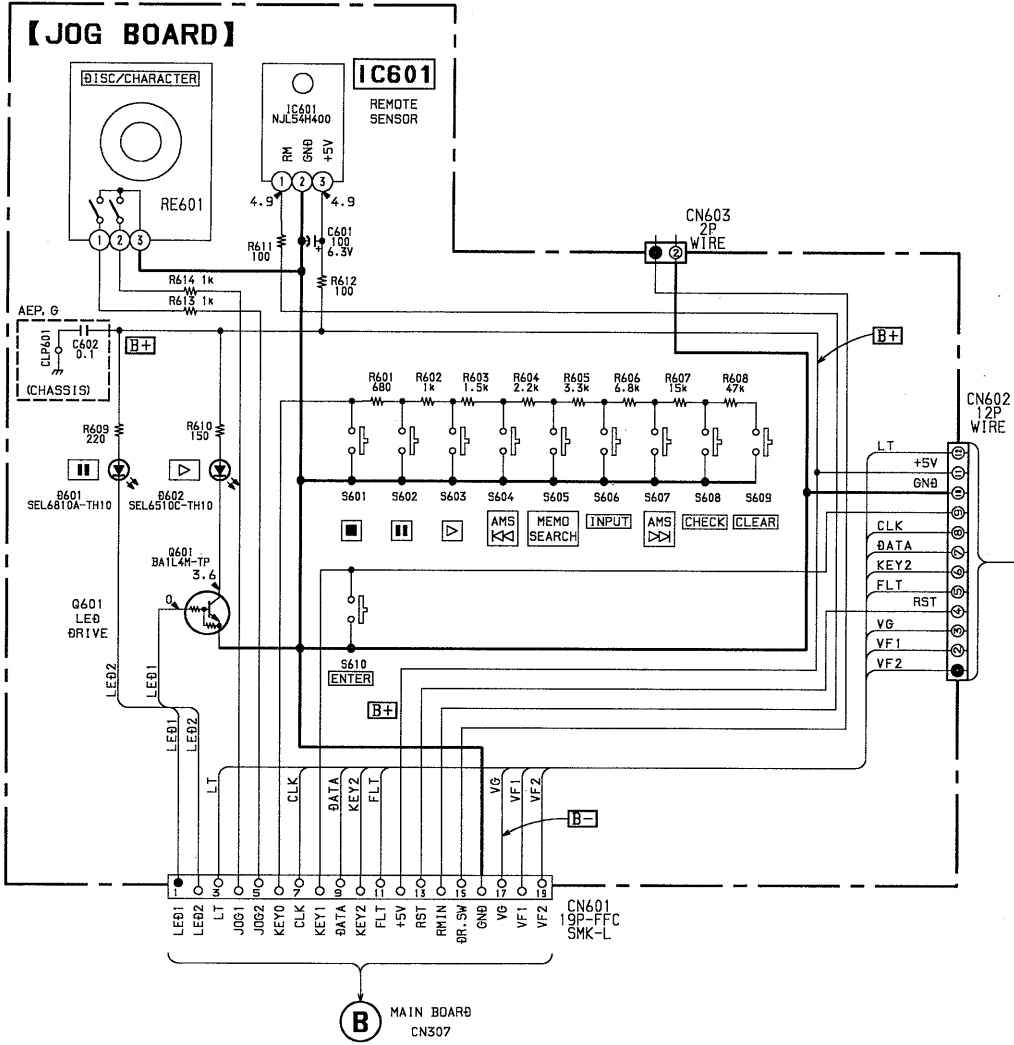

• Semiconductor Location

Ref. No.	Location
D301	G-21
D302	G-21
D303	G-20
D304	G-20
D305	G-19
D306	G-19
D307	G-18
D308	F-18
D309	C-18
D310	C-17
D311	B-17
D312	G-22
D313	G-21
D314	F-22
D315	G-19
D316	D-19
D501	C-13
D801	F-9
D802	E-12
D803	E-12
D804	E-13
IC301	E-22
IC302	E-21
IC303	C-20
IC304	D-17
IC305	F-18
IC306	C-19
IC307	D-24
IC308	F-25
IC309	F-24
IC502	A-15
IC801	G-12
IC802	G-13
IC803	H-13
Q101	G-25
Q102	G-25
Q201	G-24
Q202	G-24
Q301	F-19
Q303	G-23
Q304	G-23
Q305	G-22
Q306	D-20
Q307	B-18
Q502	B-13
Q801	H-9

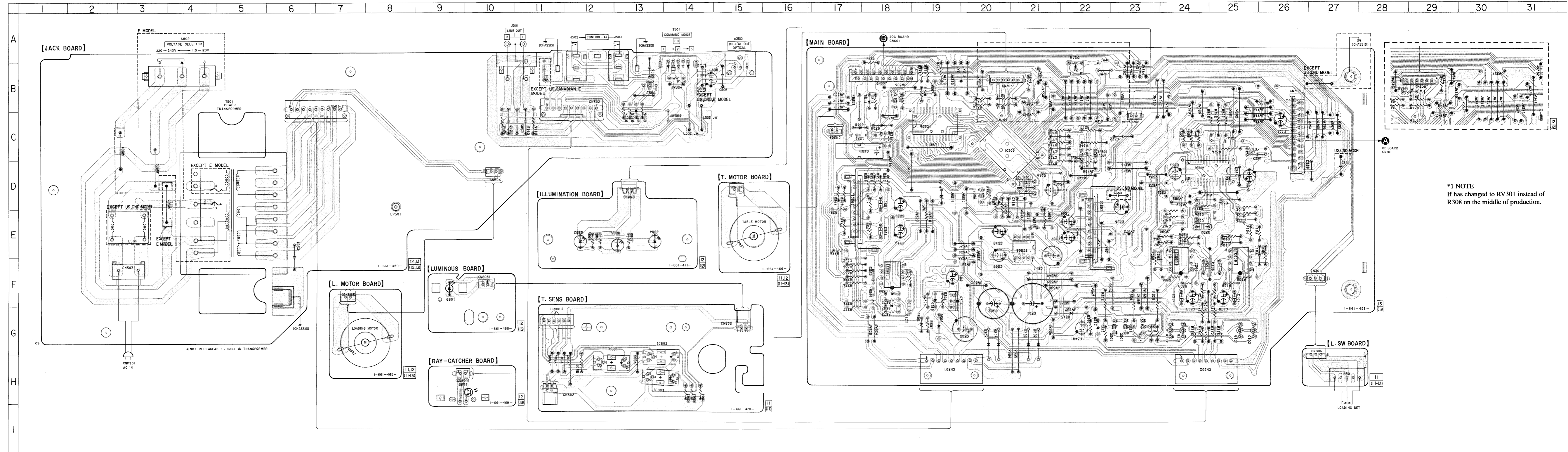

*1 NOTE
If has changed to RV301 instead of R308 on the middle of production.

Note:
 • : parts extracted from the component side.
 • Δ : internal component.
 • □ : Pattern from the side which enable seeing.

— MAIN SECTION —

See page 47—50

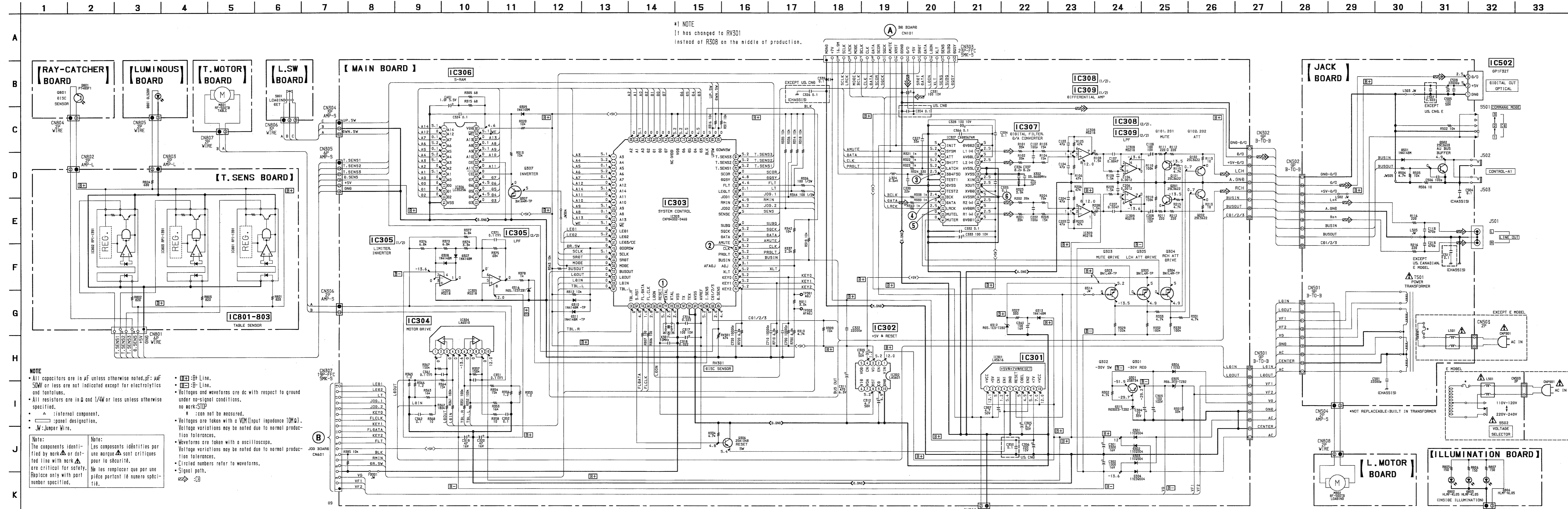

*1 NOTE
 † has changed to RV301
 instead of R308 on the middle of production.

NOTE

- All capacitors are in μF unless otherwise noted. μF : μF 50W or less are not indicated except for electrolytics and tantalums.
- All resistors are in Ω and $1/4\text{W}$ or less unless otherwise specified.
- Δ : internal component.
- \square : panel designation.
- --- : Jumper Wire.

Note: The components identified by mark Δ or dotted line with mark Δ are critical for safety. Replace only with part number specified.

Note: Les composants identifiés par une marque Δ sont critiques pour la sécurité. Ne les remplacer que par une pièce portant le numéro spécifié.

Legend:

- --- : Bt Line.
- --- : B Line.
- Voltages and waveforms are dc with respect to ground under no-signal conditions.
- \square : com not to be measured.
- Voltages are taken with a VOM (input impedance $10\text{M}\Omega$). Voltage variations may be noted due to normal production tolerances.
- Waveforms are taken with an oscilloscope. Voltage variations may be noted due to normal production tolerances.
- Circled numbers refer to waveforms.
- Signal path.
- \rightarrow : CB

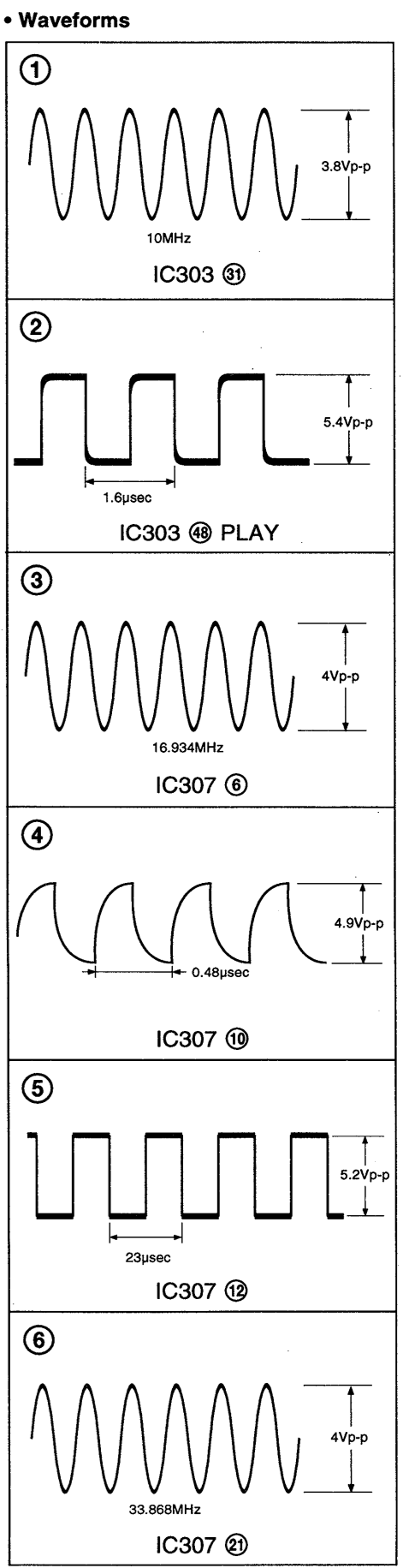

ELECTRICAL PARTS LIST

ILLUMINATION

JACK

Note:

The components identified by mark Δ or dotted line with mark Δ are critical for safety. Replace only with part number specified.

Les composants identifiés par une marque Δ sont critiques pour la sécurité. Ne les remplacer que par une pièce portant le numéro spécifié.

When indicating parts by reference number, please include the board name.

- Due to standardization, replacements in the parts list may be different from the parts specified in the diagrams or the components used on the set.
- -XX, -X mean standardized parts, so they may have some difference from the original one.
- Items marked "*" are not stocked since they are seldom required for routine service. Some delay should be anticipated when ordering these items.
- RESISTORS
All resistors are in ohms
METAL: Metal-film resistor
METAL OXIDE: Metal Oxide-film resistor
F : nonflammable
- SEMICONDUCTORS
In each case, u: μ , for example:
uA...: μ A..., uPA...: μ PA..., uPB...: μ PB..., uPC...: μ PC..., uPD...: μ PD...
- CAPACITORS
uF : μ F
- COILS
uH : μ H
- Abbreviation
CND : Canadian model
G : German model
SP : Singapore model
AUS : Australian model

Ref. No.	Part No.	Description	Remark	Ref. No.	Part No.	Description	Remark
*	1-661-471-11	ILLUMINATION BOARD *****				< DIODE >	
		< CONNECTOR >		D501	8-719-987-63	DIODE 1N4148M	
		< DIODE >				< IC >	
CN810	1-506-481-11	PIN, CONNECTOR 2P		IC502	8-749-921-12	IC GP1F32T (OPTICAL DIGITAL OUT)	
		< DIODE >				< JACK >	
D802	8-719-059-65	DIODE HLMF-KL05 (INSIDE ILLUMINATION)		J501	1-770-719-11	JACK, PIN 2P (LINE OUT)	
D803	8-719-059-65	DIODE HLMF-KL05 (INSIDE ILLUMINATION)		* J502	1-764-188-11	JACK (SMALL TYPE)(DIA. 3.5)(CONTROL A1)	
D804	8-719-059-65	DIODE HLMF-KL05 (INSIDE ILLUMINATION)		* J503	1-764-188-11	JACK (SMALL TYPE)(DIA. 3.5)(CONTROL A1)	
		< RESISTOR >				< COIL >	
R805	1-249-407-11	CARBON 150 5% 1/4W F		Δ L501	1-421-915-11	COIL, LINE FILTER (EXCEPT US, CND)	
R806	1-249-407-11	CARBON 150 5% 1/4W F				< TRANSISTOR >	
R807	1-249-407-11	CARBON 150 5% 1/4W F		Q502	8-729-620-05	TRANSISTOR 2SC2603-EF	

*	1-661-459-11	JACK BOARD *****				< RESISTOR >	
*	4-962-200-01	PLATE (TR), GROUND		R116	1-249-409-11	CARBON 220 5% 1/4W F	
		< CAPACITOR >		R216	1-249-409-11	CARBON 220 5% 1/4W F	
C113	1-162-290-31	CERAMIC 470PF 10% 50V		R502	1-249-429-11	CARBON 10K 5% 1/4W	
C213	1-162-290-31	CERAMIC 470PF 10% 50V		R504	1-249-425-11	CARBON 4.7K 5% 1/4W F	
C501	1-161-494-00	CERAMIC 0.022uF 25V		R505	1-249-429-11	CARBON 10K 5% 1/4W	
C504	1-164-159-11	CERAMIC 0.1uF 50V		R506	1-249-393-11	CARBON 10 5% 1/4W F	
C505	1-126-052-11	ELECT 100uF 20% 50V				< SWITCH >	
C506	1-162-282-31	CERAMIC 100PF 10% 50V		S501	1-762-151-11	SWITCH, SLIDE (COMMAND MODE)	
C507	1-161-494-00	CERAMIC 0.022uF 25V		Δ S502	1-572-675-11	SWITCH, POWER VOLTAGE CHANGE (VOLTAGE SELECTOR)(E)	
C508	1-161-494-00	CERAMIC 0.022uF 30% 25V				< TRANSFORMER >	
C511	1-164-159-11	CERAMIC 0.1uF 50V		Δ T501	1-429-666-11	TRANSFORMER, POWER (US,CND)	
		(EXCEPT US, CND, E)		Δ T501	1-429-667-11	TRANSFORMER, POWER (AEP,G,AUS,SP)	
		< CONNECTOR >		Δ T501	1-429-669-11	TRANSFORMER, POWER (E)	
CN501	1-770-724-11	CONNECTOR, BOARD TO BOARD 9P		*****			
CN502	1-770-724-11	CONNECTOR, BOARD TO BOARD 9P					
CN503	1-580-230-11	PIN, CONNECTOR (PC BOARD) 2P					
* CN504	1-568-951-11	PIN, CONNECTOR 2P					

JOG	L.MOTOR	L.SW	LUMINOUS	MAIN
------------	----------------	-------------	-----------------	-------------

Ref. No.	Part No.	Description	Remark			
*	A-4699-046-A	JOG BOARD, COMPLETE (US, CND, E, AUS, SP)	*****			
*	A-4699-508-A	JOG BOARD, COMPLETE (AEP, G)	*****			
		< CAPACITOR >				
C601	1-124-584-00	ELECT	100uF	20%	10V	
C602	1-164-159-11	CERAMIC	0.1uF		50V	(AEP, G)
		< LEAD >				
CLP601	1-690-880-41	LEAD (WITH CONNECTOR) (AEP, G)				
		< CONNECTOR >				
* CN601	1-568-862-11	SOCKET, CONNECTOR 19P				
		< DIODE >				
D601	8-719-313-45	DIODE SEL6810A-TH10 (■)				
D602	8-719-303-02	DIODE SEL2510C-D (▷)				
		< IC >				
IC601	8-759-373-49	IC NJL54H400				
		< TRANSISTOR >				
Q601	8-729-900-89	TRANSISTOR DTC144ES				
		< RESISTOR >				
R601	1-249-415-11	CARBON	680	5%	1/4W	F
R602	1-249-417-11	CARBON	1K	5%	1/4W	F
R603	1-249-419-11	CARBON	1.5K	5%	1/4W	F
R604	1-249-421-11	CARBON	2.2K	5%	1/4W	F
R605	1-247-843-11	CARBON	3.3K	5%	1/4W	
R606	1-249-427-11	CARBON	6.8K	5%	1/4W	F
R607	1-249-431-11	CARBON	15K	5%	1/4W	
R608	1-249-437-11	CARBON	47K	5%	1/4W	
R609	1-249-409-11	CARBON	220	5%	1/4W	
R610	1-249-407-11	CARBON	150	5%	1/4W	
R611	1-247-807-31	CARBON	100	5%	1/4W	
R612	1-247-807-31	CARBON	100	5%	1/4W	
R613	1-249-417-11	CARBON	1K	5%	1/4W	
R614	1-249-417-11	CARBON	1K	5%	1/4W	
		< JOG SWITCH >				
RE601	1-762-717-11	SWITCH, JOG (DISC/CHARACTER)				
		< SWITCH >				
S601	1-572-184-11	SWITCH, TACTILE (■)				
S602	1-572-184-11	SWITCH, TACTILE (■)				
S603	1-572-184-11	SWITCH, TACTILE (▷)				
S604	1-572-184-11	SWITCH, TACTILE (◁)				

Ref. No.	Part No.	Description	Remark			
S605	1-572-184-11	SWITCH, TACTILE (MEMO SEARCH)				
S606	1-572-184-11	SWITCH, TACTILE (INPUT)				
S607	1-572-184-11	SWITCH, TACTILE (▷▷)				
S608	1-572-184-11	SWITCH, TACTILE (CHECK)				
S609	1-572-184-11	SWITCH, TACTILE (CLEAR)				
S610	1-572-184-11	SWITCH, TACTILE (ENTER)				

*	1-661-465-11	L.MOTOR BOARD	*****			
		< MOTOR >				
M802	A-4604-847-A	MOTOR ASSY, LOADING (LOADING)				

*	1-661-467-11	L.SW BOARD	*****			
		< SWITCH >				
S801	1-571-300-21	SWITCH, ROTARY (LOADING DET)				

*	1-661-468-11	LUMINOUS BOARD	*****			
*	4-976-473-01	HOLDER (LED-S)				
		< DIODE >				
D801	8-719-055-84	DIODE GL-528VS1				

*	A-4699-040-A	MAIN BOARD, COMPLETE (US,CND)	*****			
*	A-4699-041-A	MAIN BOARD, COMPLETE (AEP,G,E,AUS,SP)	*****			
	7-685-871-01	SCREW +BVTT 3X6 (S)				
		< CAPACITOR >				
C102	1-162-282-31	CERAMIC	100PF	10%	50V	
C103	1-162-215-31	CERAMIC	47PF	5%	50V	
C104	1-162-215-31	CERAMIC	47PF	5%	50V	
C106	1-130-472-00	MYLAR	0.0012uF	5%	50V	
C107	1-106-359-00	MYLAR	4700PF	5%	200V	
C108	1-126-052-11	ELECT	100uF	20%	10V	
C202	1-162-282-31	CERAMIC	100PF	10%	50V	
C203	1-162-215-31	CERAMIC	47PF	5%	50V	
C204	1-162-215-31	CERAMIC	47PF	5%	50V	
C206	1-130-472-00	MYLAR	0.0012uF	5%	50V	
C207	1-106-359-00	MYLAR	4700PF	5%	200V	

Ref. No.	Part No.	Description	Remark	Ref. No.	Part No.	Description	Remark
C208	1-126-052-11	ELECT	100uF 20% 10V	* CN305	1-568-955-11	PIN, CONNECTOR 6P	
C301	1-128-489-11	ELECT	3300uF 20% 16V	* CN306	1-568-951-11	PIN, CONNECTOR 2P	
C302	1-124-360-00	ELECT	1000uF 20% 16V	CN307	1-568-802-11	SOCKET, CONNECTOR 19P	
C303	1-128-563-11	ELECT	100uF 20% 100V	* CN308	1-568-951-11	PIN, CONNECTOR 2P	
C304	1-126-851-11	ELECT	22uF 20% 35V	< DIODE >			
C305	1-126-163-11	ELECT	4.7uF 20% 50V	D301	8-719-210-21	DIODE 11EQS04	
C306	1-126-101-11	ELECT	100uF 20% 16V	D302	8-719-210-21	DIODE 11EQS04	
C307	1-126-163-11	ELECT	4.7uF 20% 50V	D303	8-719-210-21	DIODE 11EQS04	
C308	1-124-472-11	ELECT	470uF 20% 10V	D304	8-719-210-21	DIODE 11EQS04	
C309	1-126-163-11	ELECT	4.7uF 20% 50V	D305	8-719-109-93	DIODE RD6.2ESB2	
C310	1-126-163-11	ELECT	4.7uF 20% 50V	D306	8-719-024-99	DIODE 11ES2-NTA2B	
C311	1-124-472-11	ELECT	470uF 20% 10V	D307	8-719-987-63	DIODE 1N4148M	
C316	1-161-494-00	CERAMIC	0.022uF 25V	D308	8-719-987-63	DIODE 1N4148M	
C317	1-126-052-11	ELECT	100uF 20% 10V	D309	8-719-987-63	DIODE 1N4148M	
C318	1-161-494-00	CERAMIC	0.022uF 30% 25V	D310	8-719-987-63	DIODE 1N4148M	
C319	1-126-022-11	ELECT	47uF 20% 16V	D311	8-719-987-63	DIODE 1N4148M	
C320	1-126-022-11	ELECT	47uF 20% 16V	D312	8-719-109-85	DIODE RD5.1ES-B2	
C322	1-161-494-00	CERAMIC	0.022uF 30% 25V	D313	8-719-987-63	DIODE 1N4148M	
C324	1-164-159-11	CERAMIC	0.1uF 50V	D315	8-719-110-72	DIODE RD30ESB2	
C326	1-164-159-11	CERAMIC	0.1uF 50V	D316	8-719-109-84	DIODE RD5.1ES-B1	
C327	1-162-211-31	CERAMIC	33PF 5% 50V	< IC >			
C328	1-126-052-11	ELECT	100uF 20% 10V	IC301	8-759-330-29	IC LA5616	
C330	1-162-207-31	CERAMIC	22PF 5% 50V	IC302	8-759-821-93	IC LA5601	
C331	1-126-052-11	ELECT	100uF 20% 10V	IC303	8-752-878-76	IC CXP84332-047Q	
C332	1-164-159-11	CERAMIC	0.1uF 50V	IC304	8-759-822-38	IC LA6510	
C333	1-126-052-11	ELECT	100uF 20% 10V	IC305	8-759-634-51	IC M5218AP	
C334	1-164-159-11	CERAMIC	0.1uF 50V	IC306	8-759-374-72	IC LC35256AM-10	
C335	1-164-159-11	CERAMIC	0.1uF 50V	IC307	8-759-362-47	IC CXD8567AM	
C336	1-162-198-31	CERAMIC	8.2PF 10% 50V	IC308	8-759-634-51	IC M5218AP	
C337	1-162-198-31	CERAMIC	8.2PF 10% 50V	IC309	8-759-634-51	IC M5218AP	
C339	1-164-159-11	CERAMIC	0.1uF 50V	< COIL >			
C340	1-126-052-11	ELECT	100uF 20% 16V	L304	1-412-297-11	INDUCTOR 3.3uH	
C350	1-164-159-11	CERAMIC	0.1uF 50V	< TRANSISTOR >			
C351	1-136-165-00	FILM	0.1uF 5% 50V	Q101	8-729-141-26	TRANSISTOR 2SC3622A-LK	
C352	1-164-159-11	CERAMIC	0.1uF 50V	Q102	8-729-141-26	TRANSISTOR 2SC3622A-LK	
C354	1-164-159-11	CERAMIC	0.1uF 50V	Q201	8-729-141-26	TRANSISTOR 2SC3622A-LK	
C361	1-136-165-00	FILM	0.1uF 5% 50V	Q202	8-729-141-26	TRANSISTOR 2SC3622A-LK	
C362	1-164-159-11	CERAMIC	0.1uF 50V	Q301	8-729-140-97	TRANSISTOR 2SB734-34	
C366	1-164-159-11	CERAMIC	0.1uF 50V	Q303	8-729-900-65	TRANSISTOR DTA144ES	
C371	1-136-165-00	FILM	0.1uF 5% 50V	Q304	8-729-900-65	TRANSISTOR DTA144ES	
C401	1-110-489-11	CAPACITOR	1F 5.5V	Q305	8-729-900-65	TRANSISTOR DTA144ES	
C700	1-162-306-11	CERAMIC	0.01uF 30% 16V	Q306	8-729-119-76	TRANSISTOR 2SA1175-HFE	
C710	1-162-306-11	CERAMIC	0.01uF 30% 16V	Q307	8-729-900-80	TRANSISTOR DTC114ES	
C720	1-162-306-11	CERAMIC	0.01uF 30% 16V	< RESISTOR >			
< CONNECTOR >				R101	1-249-436-11	CARBON 39K 5% 1/4W	
CN301	1-770-728-11	CONNECTOR, BOARD TO BOARD 9P		R102	1-249-436-11	CARBON 39K 5% 1/4W	
CN302	1-770-728-11	CONNECTOR, BOARD TO BOARD 9P		R103	1-249-431-11	CARBON 15K 5% 1/4W	
* CN303	1-568-839-11	SOCKET, CONNECTOR 23P					
CN304	1-506-468-11	PIN, CONNECTOR 3P					

MAIN

Ref. No.	Part No.	Description	Remark	Ref. No.	Part No.	Description	Remark
R104	1-249-431-11	CARBON	15K 5% 1/4W	R334	1-249-425-11	CARBON	4.7K 5% 1/4W F
R105	1-249-437-11	CARBON	47K 5% 1/4W	R335	1-249-429-11	CARBON	10K 5% 1/4W
R106	1-249-437-11	CARBON	47K 5% 1/4W	R336	1-249-429-11	CARBON	10K 5% 1/4W
R108	1-249-419-11	CARBON	1.5K 5% 1/4W F	R337	1-249-421-11	CARBON	2.2K 5% 1/4W F
R109	1-249-419-11	CARBON	1.5K 5% 1/4W F	R338	1-249-417-11	CARBON	1K 5% 1/4W F
R110	1-249-441-11	CARBON	100K 5% 1/4W	R339	1-249-417-11	CARBON	1K 5% 1/4W F
R111	1-249-409-11	CARBON	220 5% 1/4W F	R340	1-249-417-11	CARBON	1K 5% 1/4W F
R112	1-249-409-11	CARBON	220 5% 1/4W F	R342	1-249-429-11	CARBON	10K 5% 1/4W
R113	1-249-393-11	CARBON	10 5% 1/4W F	R343	1-249-429-11	CARBON	10K 5% 1/4W
R115	1-249-425-11	CARBON	4.7K 5% 1/4W F	R344	1-247-807-31	CARBON	100 5% 1/4W F
R201	1-249-436-11	CARBON	39K 5% 1/4W	R351	1-249-441-11	CARBON	100K 5% 1/4W
R202	1-249-436-11	CARBON	39K 5% 1/4W	R352	1-249-441-11	CARBON	100K 5% 1/4W
R203	1-249-431-11	CARBON	15K 5% 1/4W	R353	1-247-860-11	CARBON	16K 5% 1/4W
R204	1-249-431-11	CARBON	15K 5% 1/4W	R354	1-249-431-11	CARBON	15K 5% 1/4W
R205	1-249-437-11	CARBON	47K 5% 1/4W	R355	1-249-382-11	CARBON	1.2 5% 1/6W F
R206	1-249-437-11	CARBON	47K 5% 1/4W	R356	1-249-382-11	CARBON	1.2 5% 1/6W F
R208	1-249-419-11	CARBON	1.5K 5% 1/4W F	R357	1-247-883-00	CARBON	150K 5% 1/4W
R209	1-249-419-11	CARBON	1.5K 5% 1/4W F	R358	1-249-393-11	CARBON	10 5% 1/4W F
R210	1-249-441-11	CARBON	100K 5% 1/4W	R361	1-247-885-00	CARBON	180K 5% 1/4W
R211	1-249-409-11	CARBON	220 5% 1/4W F	R362	1-247-885-00	CARBON	180K 5% 1/4W
R212	1-249-409-11	CARBON	220 5% 1/4W F	R363	1-247-860-11	CARBON	16K 5% 1/4W
R213	1-249-393-11	CARBON	10 5% 1/4W F	R364	1-249-431-11	CARBON	15K 5% 1/4W
R215	1-249-425-11	CARBON	4.7K 5% 1/4W F	R365	1-249-382-11	CARBON	1.2 5% 1/6W F
R301	1-249-435-11	CARBON	33K 5% 1/4W	R366	1-249-382-11	CARBON	1.2 5% 1/6W F
R302	1-249-425-11	CARBON	4.7K 5% 1/4W F	R367	1-247-883-00	CARBON	150K 5% 1/4W
R305	1-249-403-11	CARBON	68 5% 1/4W F	R368	1-249-393-11	CARBON	10 5% 1/4W F
R306	1-247-807-31	CARBON	100 5% 1/4W F	R373	1-249-427-11	CARBON	6.8K 5% 1/4W F
R307	1-247-807-31	CARBON	100 5% 1/4W F	R374	1-247-843-11	CARBON	3.3K 5% 1/4W
R309	1-249-429-11	CARBON	10K 5% 1/4W	R375	1-249-439-11	CARBON	68K 5% 1/4W
R310	1-249-425-11	CARBON	4.7K 5% 1/4W F	R376	1-249-427-11	CARBON	6.8K 5% 1/4W F
R311	1-247-843-11	CARBON	3.3K 5% 1/4W	R377	1-249-427-11	CARBON	6.8K 5% 1/4W F
R312	1-249-429-11	CARBON	10K 5% 1/4W	R378	1-249-417-11	CARBON	1K 5% 1/4W F
R313	1-249-429-11	CARBON	10K 5% 1/4W	R385	1-249-429-11	CARBON	10K 5% 1/4W
R314	1-249-429-11	CARBON	10K 5% 1/4W	R700	1-249-427-11	CARBON	6.8K 5% 1/4W F
R315	1-249-403-11	CARBON	68 5% 1/4W F	R710	1-249-427-11	CARBON	6.8K 5% 1/4W F
R316	1-249-429-11	CARBON	10K 5% 1/4W	R720	1-249-427-11	CARBON	6.8K 5% 1/4W F
R317	1-249-429-11	CARBON	10K 5% 1/4W				
R318	1-249-429-11	CARBON	10K 5% 1/4W			< VARIABLE RESISTOR >	
R319	1-249-429-11	CARBON	10K 5% 1/4W	RV301	1-238-602-11	RES, ADJ, CARBON 47K (Suffix No. -12)	
R320	1-249-429-11	CARBON	10K 5% 1/4W	RV301	1-230-723-11	RES, ADJ, CARBON 47K (Suffix No. -13)	
R321	1-249-417-11	CARBON	1K 5% 1/4W F			< VIBRATOR >	
R322	1-249-417-11	CARBON	1K 5% 1/4W F	X301	1-579-175-11	VIBRATOR, CERAMIC (10MHz)	
R323	1-249-417-11	CARBON	1K 5% 1/4W F	X302	1-767-155-11	VIBRATOR, CRYSTAL (33.8688MHz)	
R324	1-249-411-11	CARBON	330 5% 1/4W			*****	
R325	1-249-424-11	CARBON	3.9K 5% 1/4W F				
R326	1-247-807-31	CARBON	100 5% 1/4W F				
R327	1-249-411-11	CARBON	330 5% 1/4W				
R329	1-249-441-11	CARBON	100K 5% 1/4W				
R330	1-249-441-11	CARBON	100K 5% 1/4W				
R331	1-249-425-11	CARBON	4.7K 5% 1/4W F				
R332	1-249-441-11	CARBON	100K 5% 1/4W				
R333	1-249-425-11	CARBON	4.7K 5% 1/4W F				

Ref. No. Part No. Description Remark

* 1-661-469-11 RAY-CATCHER BOARD

4-985-300-01 HOLDER (P-T)
< TRANSISTOR >
Q801 8-729-926-31 PHOTO TRANSISTOR PT483F1S

* 1-661-466-11 T.MOTOR BOARD

< MOTOR >
M801 A-4604-847-A MOTOR ASSY, LOADING (TABLE)

* 1-661-470-11 T.SENS BOARD

< CONNECTOR >
CN802 1-506-481-11 PIN, CONNECTOR 2P
CN803 1-506-481-11 PIN, CONNECTOR 2P
< IC >
IC801 8-749-924-18 IC PHOTO INTERRUPTER RPI-1391
IC802 8-749-924-18 IC PHOTO INTERRUPTER RPI-1391
IC803 8-749-924-18 IC PHOTO INTERRUPTER RPI-1391
< RESISTOR >
R801 1-249-416-11 CARBON 820 5% 1/4W F
R802 1-249-416-11 CARBON 820 5% 1/4W F
R803 1-249-416-11 CARBON 820 5% 1/4W F
R804 1-249-415-11 CARBON 680 5% 1/4W F

MISCELLANEOUS

4 1-773-183-11 WIRE (FLAT TYPE) (23 CORE)
5 1-777-345-11 WIRE (FLAT TYPE) (19 CORE)
△ 12 1-569-007-11 ADAPTOR, CONVERSION 2P (E)
△ CNP901 1-575-042-21 CORD, POWER (US,CND)
△ CNP901 1-575-651-21 CORD, POWER (AEP,G,SP)
△ CNP901 1-696-027-11 CORD, POWER (E)
△ CNP901 1-696-845-11 CORD, POWER (AUS)
FL701 1-517-564-11 INDICATOR TUBE, FLUORESCENT
M801 A-4604-847-A MOTOR ASSY, LOADING (TABLE)
M802 A-4604-847-A MOTOR ASSY, LOADING (LOADING)
△ T501 1-429-666-11 TRANSFORMER, POWER (US,CND)
△ T501 1-429-667-11 TRANSFORMER, POWER (AEP,G,AUS,SP)
△ T501 1-429-669-11 TRANSFORMER, POWER (E)

The components identified by mark △ or dotted line with mark △ are critical for safety. Replace only with part number specified.	Les composants identifiés par une marque △ sont critiques pour la sécurité. Ne les remplacer que par une pièce portant le numéro spécifié.
--	--

