

# CDP-CX333ES/CX555ES

## SERVICE MANUAL

US Model  
Canadian Model



Photo: CX555ES

Model Name Using Similar Mechanism	CDP-CX300
CD Mechanism Type	CDM54-KIBD35B
Base Unit Type	KSM-213BFN/C2NP
Optical Pick-up Type	KSS-213B/C2N

### SPECIFICATIONS

#### Compact disc player

<b>Laser</b>	Semiconductor laser ( $\lambda = 780 \text{ nm}$ ) Emission duration: continuous
<b>Laser output</b>	Max 44.6 $\mu\text{W}$ * * This output is the value measured at a distance of 200 mm from the objective lens surface on the Optical Pick-up block with 7 mm aperture.
<b>Frequency response</b>	20 Hz to 20 kHz $\pm 0.5 \text{ dB}$
<b>Signal-to-noise ratio</b>	More than 110 dB
<b>Dynamic range</b>	More than 95 dB
<b>Harmonic distortion</b>	Less than 0.003 %
<b>Channel separation</b>	More than 100 dB

#### Outputs

	Jack type	Maximum output level	Load impedance
<b>LINE OUT</b>	Phono jacks	2 V (at 50 kilohms)	Over 10 kilohms
<b>DIGITAL OUT (OPTICAL)</b>	Optical output connector	-18 dBm	Wave length: 660 nm

#### General

##### Power requirements

Where purchased	Power requirements
USA	120 V AC, 60 Hz

**Power consumption** 17 W

**Dimensions (approx.) (w/h/d)** 430 x 189 x 484 mm (17 x 7 1/2 x 19 in.) incl. projecting parts

**Mass (approx.)** 9 kg (19 lbs 14 oz)

##### Supplied accessories

- Audio cord (1)
- CD booklet holders (3) and label (1)
- Remote commander (remote) (1)
- Size AA (LR6) batteries (3) (CDP-CX555ES)
- Size AA (NS) batteries (2) (CDP-CX333ES)

Design and specifications are subject to change without notice.

COMPACT DISC PLAYER



SONY®

# SECTION 1 SERVICING NOTES

## TABLE OF CONTENTS

<b>1.</b>	<b>SERVICING NOTES</b> .....	2
<b>2.</b>	<b>GENERAL</b> .....	8
<b>3.</b>	<b>DISASSEMBLY</b> .....	9
<b>4.</b>	<b>SERVICE MODE</b> .....	12
<b>5.</b>	<b>TEST MODE</b> .....	16
<b>6.</b>	<b>MECHANICAL ADJUSTMENTS</b> .....	17
<b>7.</b>	<b>ELECTRICAL ADJUSTMENT</b> .....	19
<b>8.</b>	<b>DIAGRAMS</b>	
8-1.	Block Diagram – BD Section – .....	21
8-2.	Block Diagram – MAIN Section – .....	22
8-3.	Note for Printed Wiring Boards and Schematic Diagrams .....	23
8-4.	Printed Wiring Board – BD Board – .....	24
8-5.	Schematic Diagram – BD Board – .....	25
8-6.	Printed Wiring Board – MAIN Board – .....	26
8-7.	Schematic Diagram – MAIN Board (1/3) – .....	28
8-8.	Schematic Diagram – MAIN Board (2/3) – .....	29
8-9.	Schematic Diagram – MAIN Board (3/3) – .....	30
8-10.	Printed Wiring Board – JACK Board – .....	31
8-11.	Schematic Diagram – JACK Board – .....	31
8-12.	Printed Wiring Board – DISPLAY Board – .....	32
8-13.	Schematic Diagram – DISPLAY Board – .....	33
8-14.	Printed Wiring Board – JOG Board – .....	34
8-15.	Schematic Diagram – JOG Board – .....	35
8-16.	Printed Wiring Boards – D.SENSOR (IN)/ D.SENSOR (OUT)/SENSOR (T) Boards – .....	36
8-17.	Schematic Diagram – D.SENSOR (IN)/ D.SENSOR (OUT)/SENSOR (T) Boards – .....	37
8-18.	Printed Wiring Boards – D.MOTOR/D.SWITCH/ KEY/LED/L.T.MOTOR/L.SWITCH (A)/ L.SWITCH (B) Boards – .....	38
8-19.	Schematic Diagram – D.MOTOR/D.SWITCH/ KEY/LED/L.T.MOTOR/L.SWITCH (A)/ L.SWITCH (B) Boards – .....	39
8-20.	Printed Wiring Board – POWER Board – .....	40
8-21.	Schematic Diagram – POWER Board – .....	41
8-22.	IC Pin Function Description .....	49
<b>9.</b>	<b>EXPLODED VIEWS</b> .....	54
<b>10.</b>	<b>ELECTRICAL PARTS LIST</b> .....	61

## MODEL IDENTIFICATION — BACK PANEL —



PART No.	MODEL
4-217-909-0□	CX333ES: US model
4-217-909-1□	CX333ES: Canadian model
4-217-909-2□	CX555ES: US model
4-217-909-3□	CX555ES: Canadian model

### SAFETY-RELATED COMPONENT WARNING!!

COMPONENTS IDENTIFIED BY MARK  $\triangle$  OR DOTTED LINE WITH MARK  $\triangle$  ON THE SCHEMATIC DIAGRAMS AND IN THE PARTS LIST ARE CRITICAL TO SAFE OPERATION. REPLACE THESE COMPONENTS WITH SONY PARTS WHOSE PART NUMBERS APPEAR AS SHOWN IN THIS MANUAL OR IN SUPPLEMENTS PUBLISHED BY SONY.

### ATTENTION AU COMPOSANT AYANT RAPPORT À LA SÉCURITÉ!

LES COMPOSANTS IDENTIFIÉS PAR UNE MARQUE  $\triangle$  SUR LES DIAGRAMMES SCHÉMATIQUES ET LA LISTE DES PIÈCES SONT CRITIQUES POUR LA SÉCURITÉ DE FONCTIONNEMENT. NE REMPLACER CES COMPOSANTS QUE PAR DES PIÈCES SONY DONT LES NUMÉROS SONT DONNÉS DANS CE MANUEL OU DANS LES SUPPLÉMENTS PUBLIÉS PAR SONY.

## SAFETY CHECK-OUT

After correcting the original service problem, perform the following safety check before releasing the set to the customer: Check the antenna terminals, metal trim, “metallized” knobs, screws, and all other exposed metal parts for AC leakage. Check leakage as described below.

## LEAKAGE TEST

The AC leakage from any exposed metal part to earth ground and from all exposed metal parts to any exposed metal part having a return to chassis, must not exceed 0.5 mA (500 microamperes). Leakage current can be measured by any one of three methods.

1. A commercial leakage tester, such as the Simpson 229 or RCA WT-540A. Follow the manufacturers’ instructions to use these instruments.
2. A battery-operated AC milliammeter. The Data Precision 245 digital multimeter is suitable for this job.
3. Measuring the voltage drop across a resistor by means of a VOM or battery-operated AC voltmeter. The “limit” indication is 0.75 V, so analog meters must have an accurate low-voltage scale. The Simpson 250 and Sanwa SH-63Trd are examples of a passive VOM that is suitable. Nearly all battery operated digital multimeters that have a 2 V AC range are suitable. (See Fig. A)

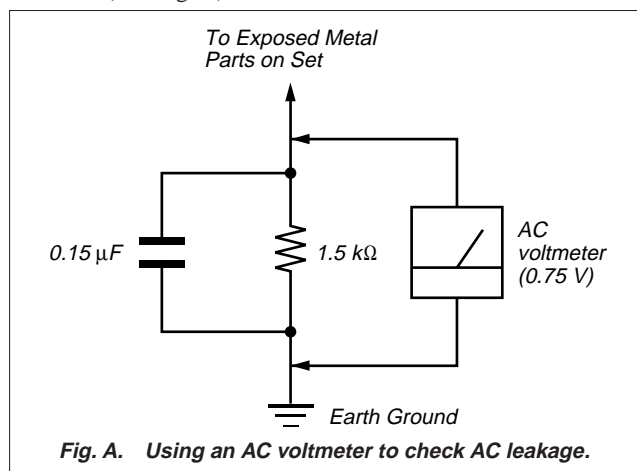

## NOTES ON HANDLING THE OPTICAL PICK-UP BLOCK OR BASE UNIT

The laser diode in the optical pick-up block may suffer electrostatic break-down because of the potential difference generated by the charged electrostatic load, etc. on clothing and the human body.

During repair, pay attention to electrostatic break-down and also use the procedure in the printed matter which is included in the repair parts.

The flexible board is easily damaged and should be handled with care.

## NOTES ON LASER DIODE EMISSION CHECK

The laser beam on this model is concentrated so as to be focused on the disc reflective surface by the objective lens in the optical pick-up block. Therefore, when checking the laser diode emission, observe from more than 30 cm away from the objective lens.

## LASER DIODE AND FOCUS SEARCH OPERATION CHECK

Carry out the “S curve check” in “CD section adjustment” and check that the S curve waveforms is output three times.

## Notes on chip component replacement

- Never reuse a disconnected chip component.
- Notice that the minus side of a tantalum capacitor may be damaged by heat.

## Flexible Circuit Board Repairing

- Keep the temperature of the soldering iron around 270 °C during repairing.
- Do not touch the soldering iron on the same conductor of the circuit board (within 3 times).
- Be careful not to apply force on the conductor when soldering or unsoldering.

## CAUTION

Use of controls or adjustments or performance of procedures other than those specified herein may result in hazardous radiation exposure.

## CD-TEXT TEST DISC

This unit is able to display the TEXT data (character information) written in the CD on its fluorescent indicator tube.

The CD-TEXT TEST DISC (TGCS-313:J-2501-126-A) is used for checking the display.

To check, perform the following procedure.

### Checking Method:

1. Turn ON the power, set the disc on the disc table with the side labeled as “test disc” as the right side, close the front cover, and chuck the disc.
2. The following will be displayed on the fluorescent indicator tube. (The display switches each time the **TIME/TEXT** button is pressed.)  
Display: CD TEXT TEST DISC (Album Title)
3. Press the **▶** button and play back the disc.
4. The following will be displayed on the fluorescent indicator tube. (If nothing is displayed, press the **TIME/TEXT** button.)  
Display: 1 kHz/0 dB/ L&R
5. Rotate **◀◀AMS▶▶** knob to switch the track. The text data of each track will be displayed.  
For details of the displayed contents for each track, refer to “Table 1: CD-TEXT TEST DISC Text Data Contents” and “Table 2: CD-TEXT TEST DISC Recorded Contents and Display”.

### Restrictions in CD-TEXT Display

In this unit, some special characters will not be displayed properly. These will be displayed as a space or a character resembling it. For details, refer to “Table 2: CD-TEXT DISC Recorded Contents and Display”.

**Table 1: CD-TEXT TEST DISC Text Data Contents (TRACKS No. 1 to 41:Normal Characters)**

TRACK No.	Displayed Contents	TRACK No.	Displayed Contents
1	1 kHz/0 dB/L&R	22	1 kHz/-90 dB/L&R
2	20 Hz/0 dB/L&R	23	Infinity Zero w/o emphasis//L&R
3	40 Hz/0 dB/L&R	24	Infinity Zero with emphasis//L&R
4	100 Hz/0 dB/L&R	25	400 Hz+7 kHz(4:1)/0 dB/L&R
5	200 Hz/0 dB/L&R	26	400 Hz+7 kHz(4:1)/-10 dB/L&R
6	500 Hz/0 dB/L&R	27	19 kHz+20 kHz(1:1)/0 dB/L&R
7	1 kHz/0 dB/L&R	28	19 kHz+20 kHz(1:1)/-10 dB/L&R
8	5 kHz/0 dB/L&R	29	100 Hz/0 dB/L*
9	7 kHz/0 dB/L&R	30	1 kHz/0 dB/L*
10	10 kHz/0 dB/L&R	31	10 kHz/0 dB/L*
11	16 kHz/0 dB/L&R	32	20 kHz/0 dB/L*
12	18 kHz/0 dB/L&R	33	100 Hz/0 dB/R*
13	20 kHz/0 dB/L&R	34	1 kHz/0 dB/R*
14	1 kHz/0 dB/L&R	35	10 kHz/0 dB/R*
15	1 kHz/-1 dB/L&R	36	20 kHz/0 dB/R*
16	1 kHz/-3 dB/L&R	37	100 Hz Squer Wave//L&R
17	1 kHz/-6 dB/L&R	38	1 kHz Squer Wave//L&R
18	1 kHz/-10 dB/L&R	39	1 kHz w/emphasis/-0.37 dB/L&R
19	1 kHz/-20 dB/L&R	40	5 kHz w/emphasis/-4.53 dB/L&R
20	1 kHz/-60 dB/L&R	41	16 kHz w/emphasis/-9.04 dB/L&R
21	1 kHz/-80 dB/L&R		

**Note:** The contents of Track No. 1 to 41 are the same as those of the current TEST DISC-their titles are displayed.

**Table 2: CD-TEXT TEST DISC Recorded Contents and Display**  
(In this unit, some special characters cannot be displayed. This is no a fault.)

TRACK No.	Recorded Contents	Displayed Contents
42	! " # \$ % & ' (21h to 27h) 1kHz 0dB L&R	← All the same
43	( ) * + , - . / (28h to 2Fh)	← All the same
44	0 1 2 3 4 5 6 7 (30h to 37h)	← All the same
45	8 9 : ; < = > ? (38h to 3Fh)	← All the same
46	@ A B C D E F G (40h to 47h)	← All the same
47	H I J K L M N O (48h to 4Fh)	← All the same
48	P Q R S T U V W (50h to 57h)	← All the same
49	X Y Z [ ¥ ] ^ _ (58h to 5Fh)	X Y Z [ \ ] ^ _ (58....
50	` a b c d e f g (60h to 67h)	← All the same
51	h i j k l m n o (68h to 6Fh)	← All the same
52	p q r s t u v w (70h to 77h)	← All the same
53	x y z {   } ~ ■ (78h to 7Fh)	x y z {   } ~ (78....
54	■ i ¢ £ ¤ ¥ ¦ § (A0h to A7h) 8859-1	i ¢ £ ¤ ¥ ¦ § (A0.... ■ is not displayed
55	♪ © ª « ¬ ® ¯ (A8h to AFh)	♪ (A8.... © ª « ¬ ® ¯ are not displayed
56	• ± ² ³ ´ µ ¶ · (B0h to B7h)	´ µ • (B0.... • ± ² ³ ¶ are not displayed
57	† † † » ¼ ½ ¾ ¿ (B8h to BFh)	† ¿ (B8.... † † † are not displayed
58	À Á Â Ã Ä Å Æ Ç (C0h to C7h)	← All the same
59	È É Ê Ë Ì Í Î Ï (C8h to CFh)	← All the same
60	Ð Ñ Ò Ó Ô Õ Ö × (D0h to D7h)	← All the same
61	Ø Ù Ú Û Ü Ý Þ ß (D8h to DFh)	Φ Ù Ú Û Ü Ý Þ ß (D8....
62	à á â ã ä å æ ç (E0h to E7h)	← All the same
63	è é ê ë ì í î ï (E8h to FFh)	← All the same
64	đ ñ ò ó ô õ ö ÷ (F0h to F7h)	đ ñ ò ó ô õ ö ÷ (F0....
65	ø ù ú û ü ý þ ÿ (F8h to FFh)	← All the same
66	No.66	← All the same
67	No.67	← All the same
to	to	to
99	No.99	← All the same

## PRECAUTIONS AT SERVICING

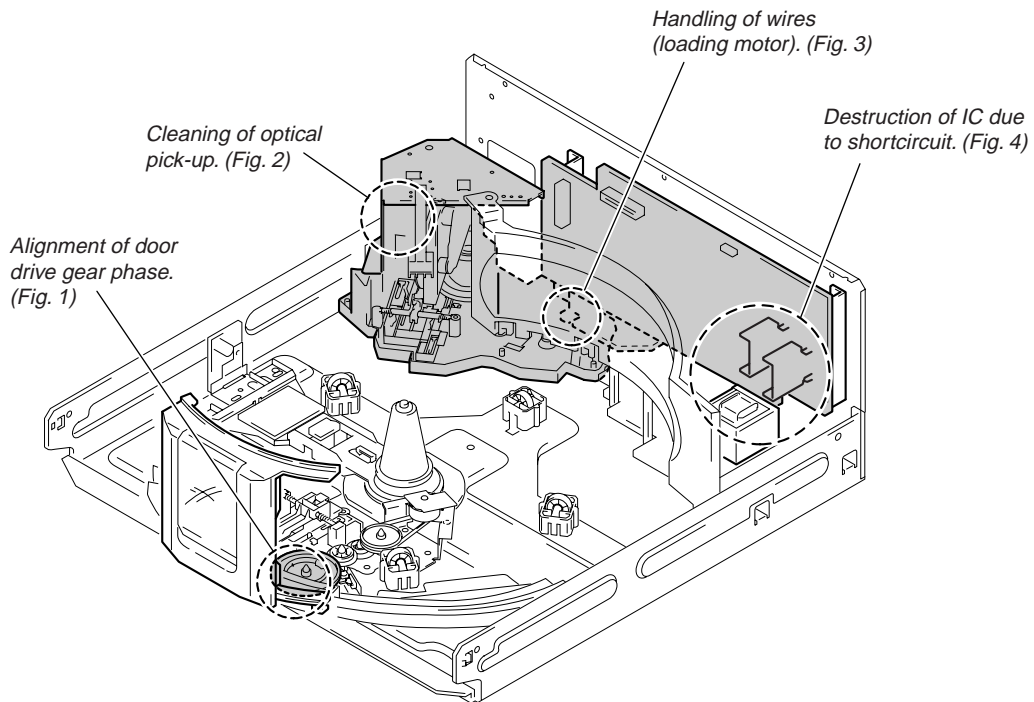

### ALIGNMENT OF DOOR DRIVE GEAR PHASE WITH DOOR (CD) (Fig. 1)

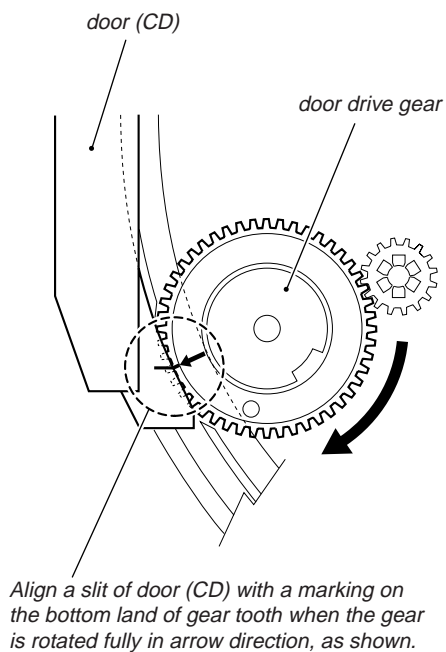

### CLEANING OF OPTICAL PICK-UP (Fig. 2)

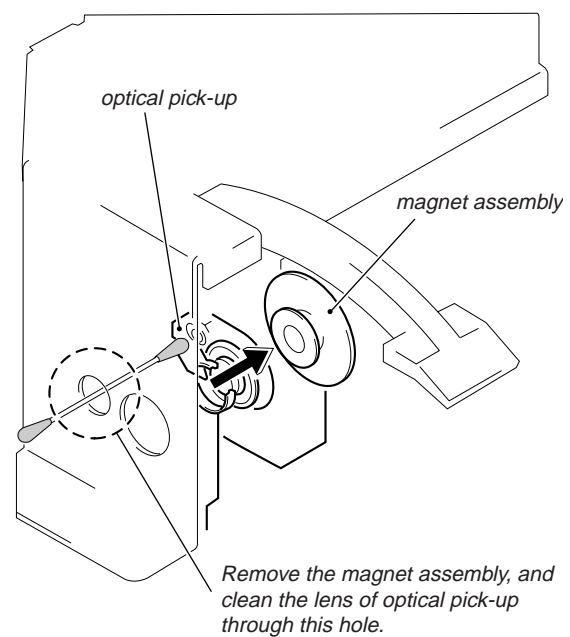

**HANDLING OF WIRES (LOADING MOTOR) (Fig. 3)**

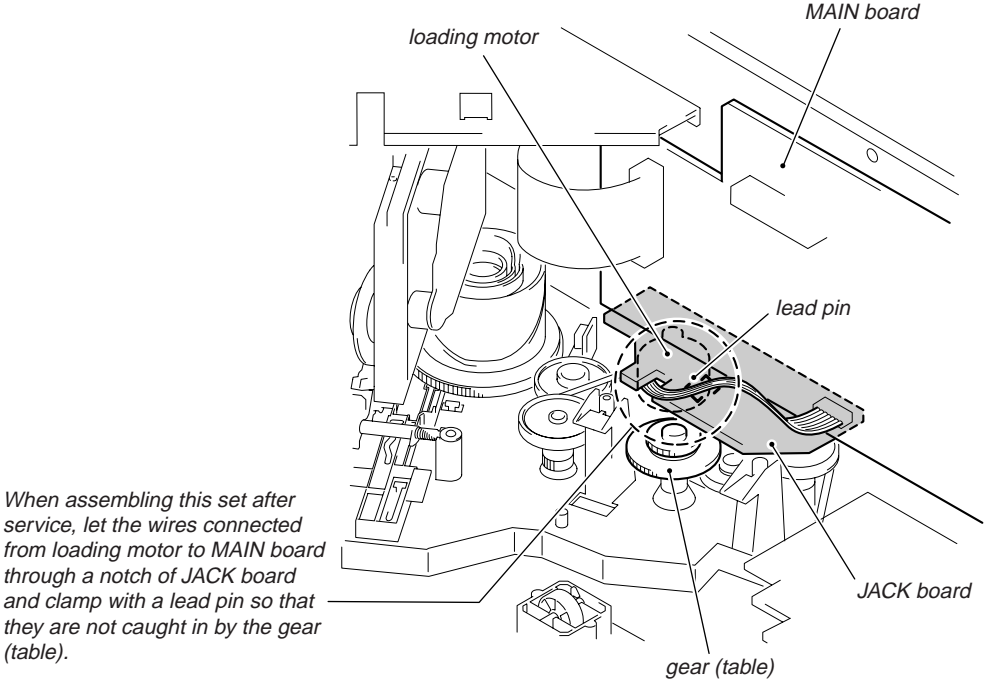

**DESTRUCTION OF IC DUE TO SHORTCIRCUIT (Fig. 4)**

*In removing or mounting the back panel or MAIN board with the power supplied, an accidental shortcircuit of heatsink to the power transformer could destroy the IC on heatsink.*

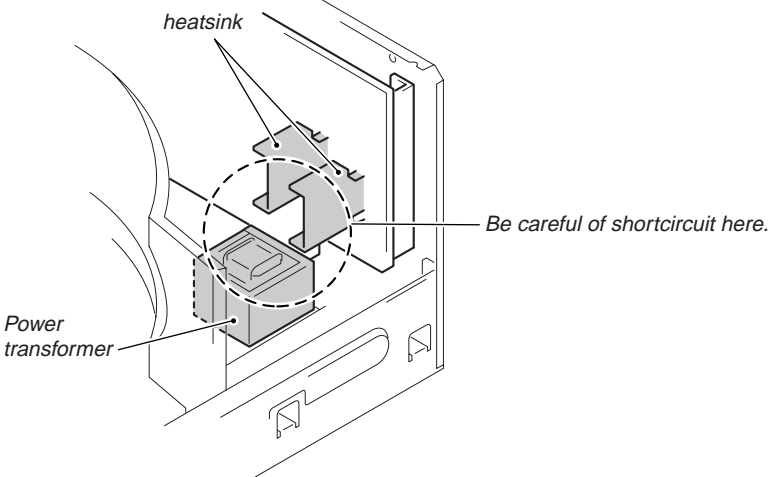

## SECTION 2 GENERAL

### • LOCATION OF CONTROLS

#### – Front Panel –

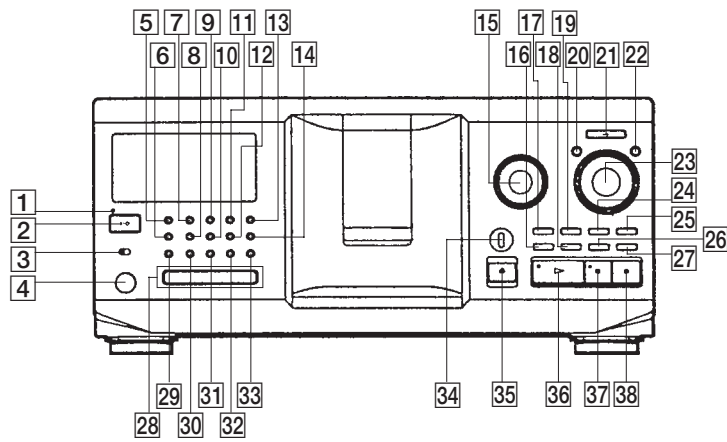

- 1 STANDBY indicator
- 2 I/⏻ button
- 3 TIMER switch
- 4 KEYBOARD jack
- 5 CONTINUE button
- 6 GROUP1 button and indicator
- 7 SHUFFLE button
- 8 GROUP2 button and indicator
- 9 PROGRAM button
- 10 GROUP3 button and indicator
- 11 REPEAT button
- 12 GROUP4 button and indicator
- 13 TIME/TEXT button
- 14 HIT LIST button and indicator
- 15 ⏮<AMS>>⏭, PUSH ENTER knob and button
- 16 MEGA CONTROL button and indicator
- 17 EASY PLAY button and indicator
- 18 X-FADE button
- 19 MEMO SEARCH button
- 20 MENU/NO button
- 21 +100 button
- 22 YES button
- 23 DISC/CHARACTER, PUSH ENTER knob and button
- 24 CHECK button
- 25 CLEAR button
- 26 NO DELAY button
- 27 FADER button
- 28 IR Repeater window (CX555ES)
- 29 GROUP5 button and indicator
- 30 GROUP6 button and indicator
- 31 GROUP7 button and indicator
- 32 GROUP8 button and indicator
- 33 GROUP FILE button
- 34 FILTER switch
- 35 ⏏ OPEN/CLOSE button
- 36 ▷ button and indicator
- 37 ▬ button and indicator
- 38 ■ button

#### – Rear Panel –

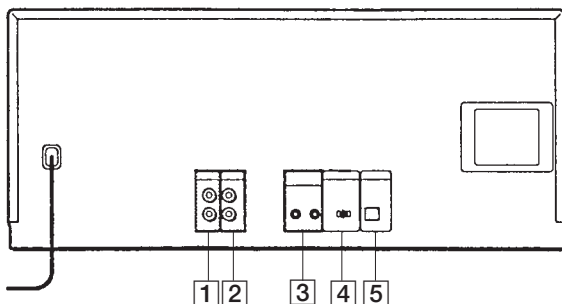

- 1 2ND CD IN jack
- 2 LINE OUT jack
- 3 CONTROL A1II jack
- 4 COMMAND MODE CD switch
- 5 DIGITAL OUT OPTICAL output terminal



## SECTION 3 DISASSEMBLY

**Note:** Follow the disassembly procedure in the numerical order given.

### FRONT PANEL ASSEMBLY

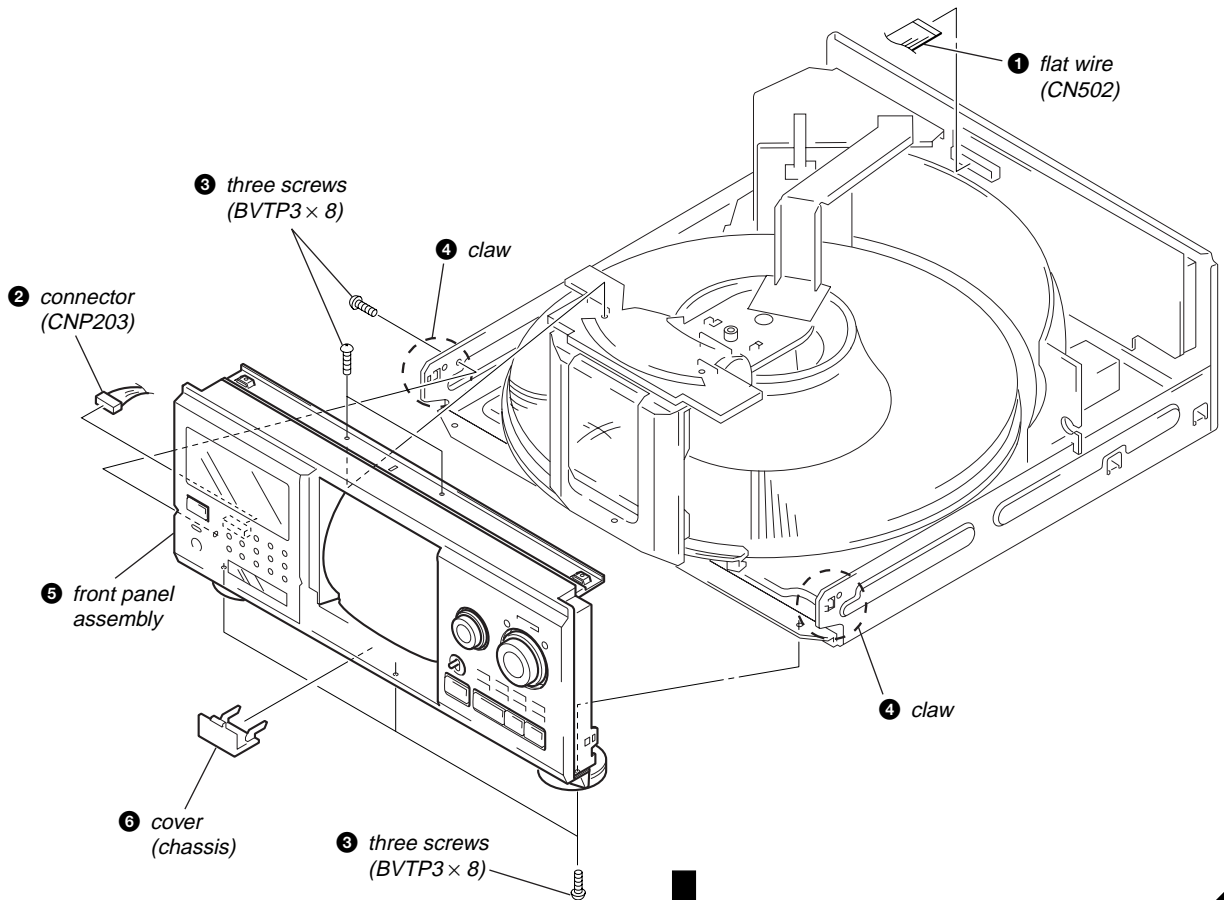

### TABLE (300) ASSEMBLY

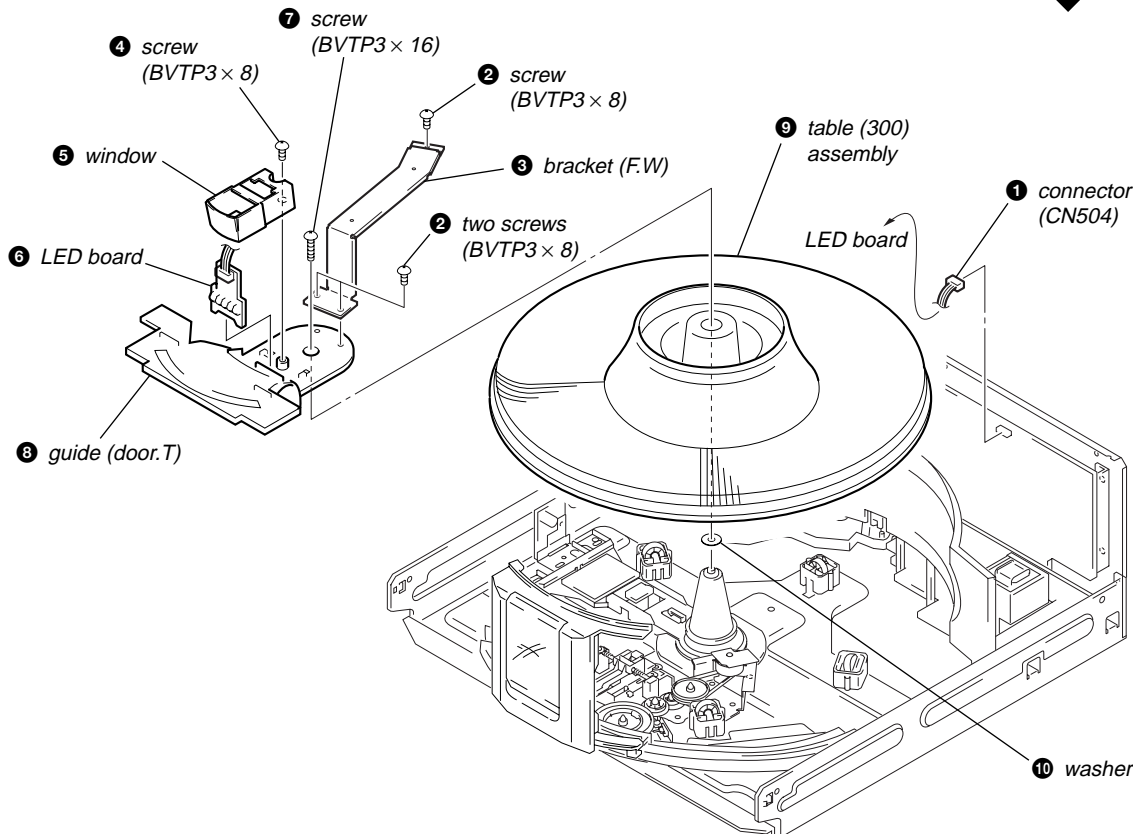

## BASE (DOOR, GEAR) ASSEMBLY AND COVER (P.T.)

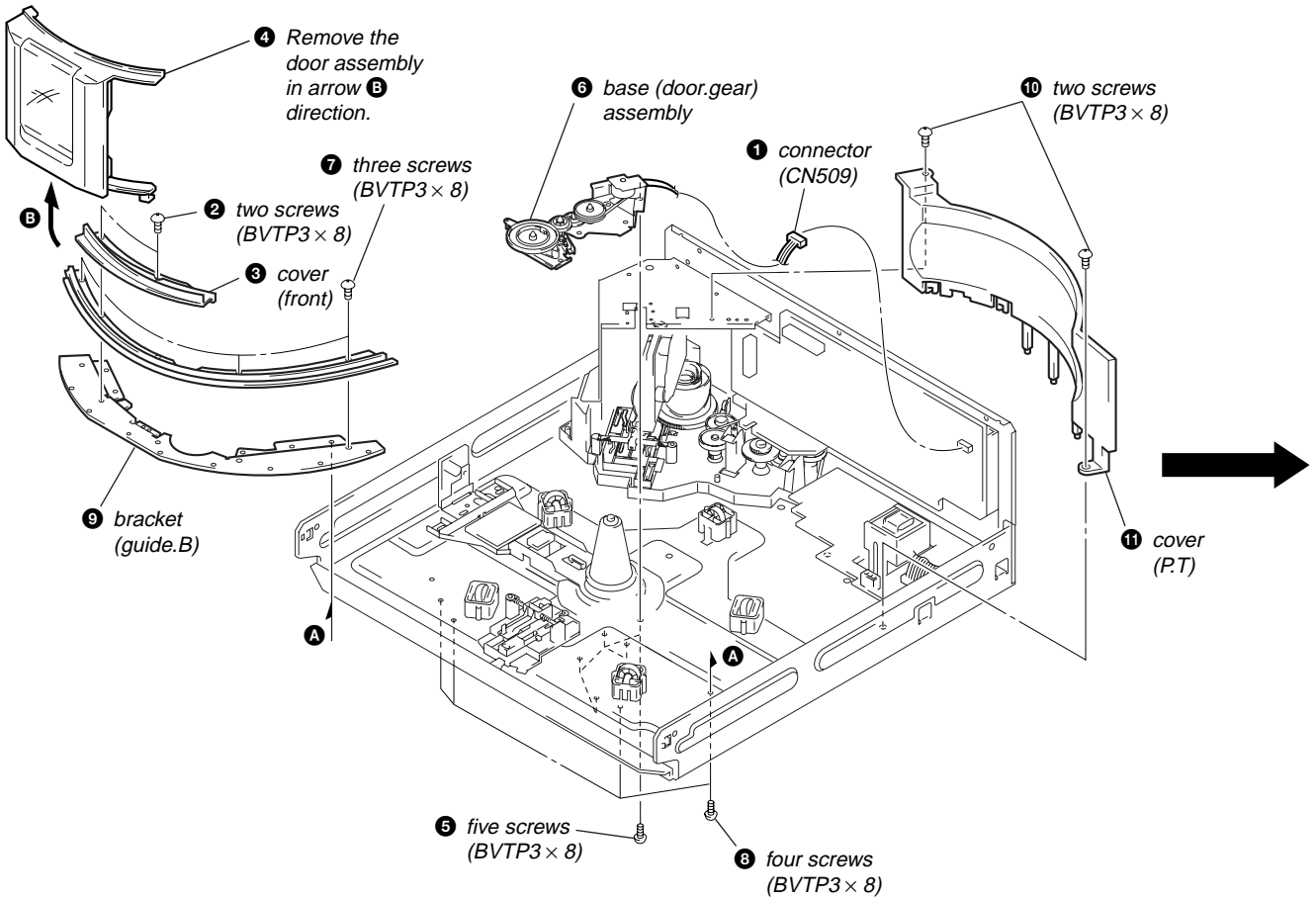

## POP-UP ASSEMBLY

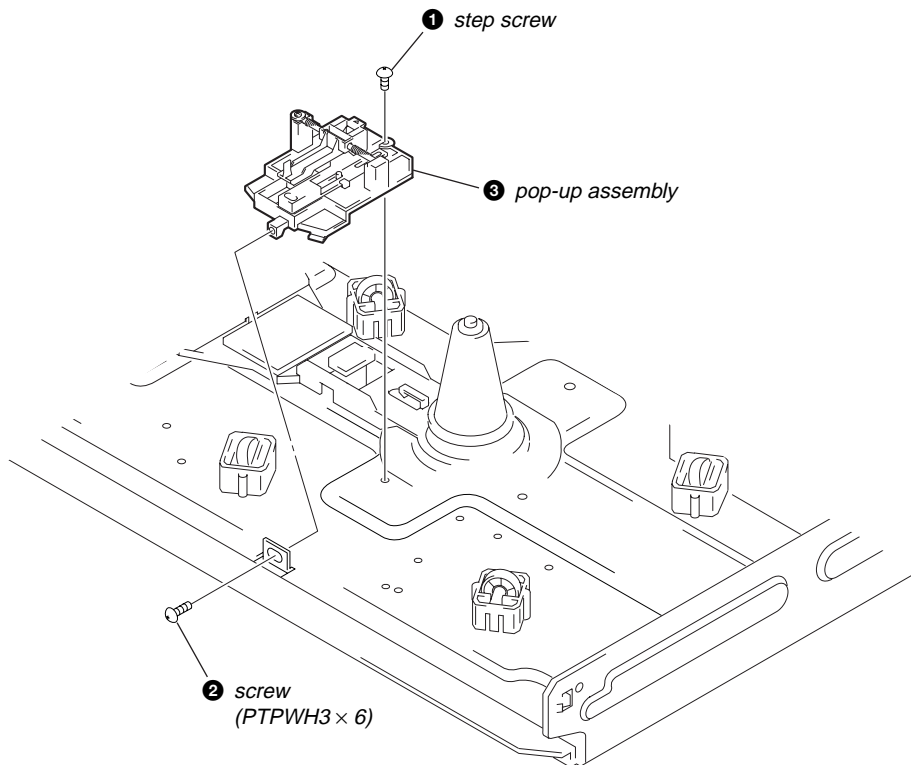

## MAIN BOARD AND BACK PANEL SECTION

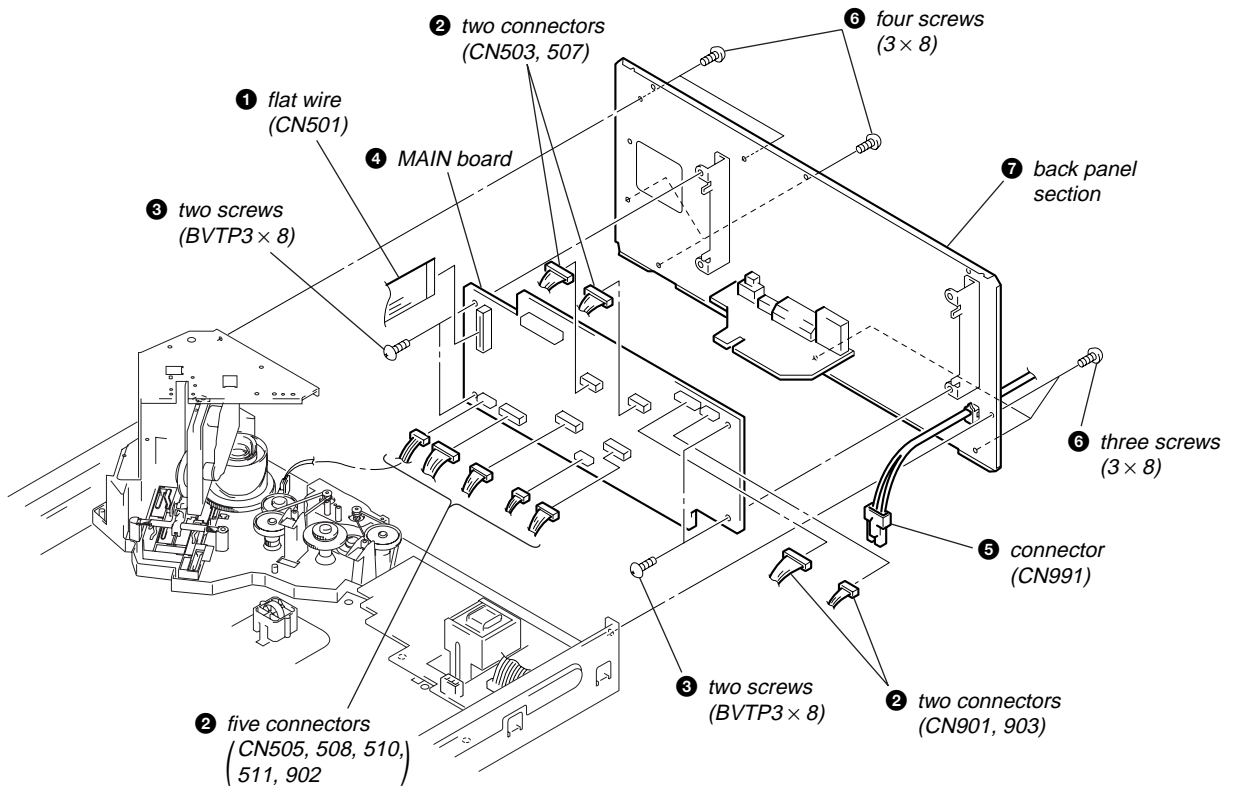

## POWER BOARD AND CDM ASSEMBLY

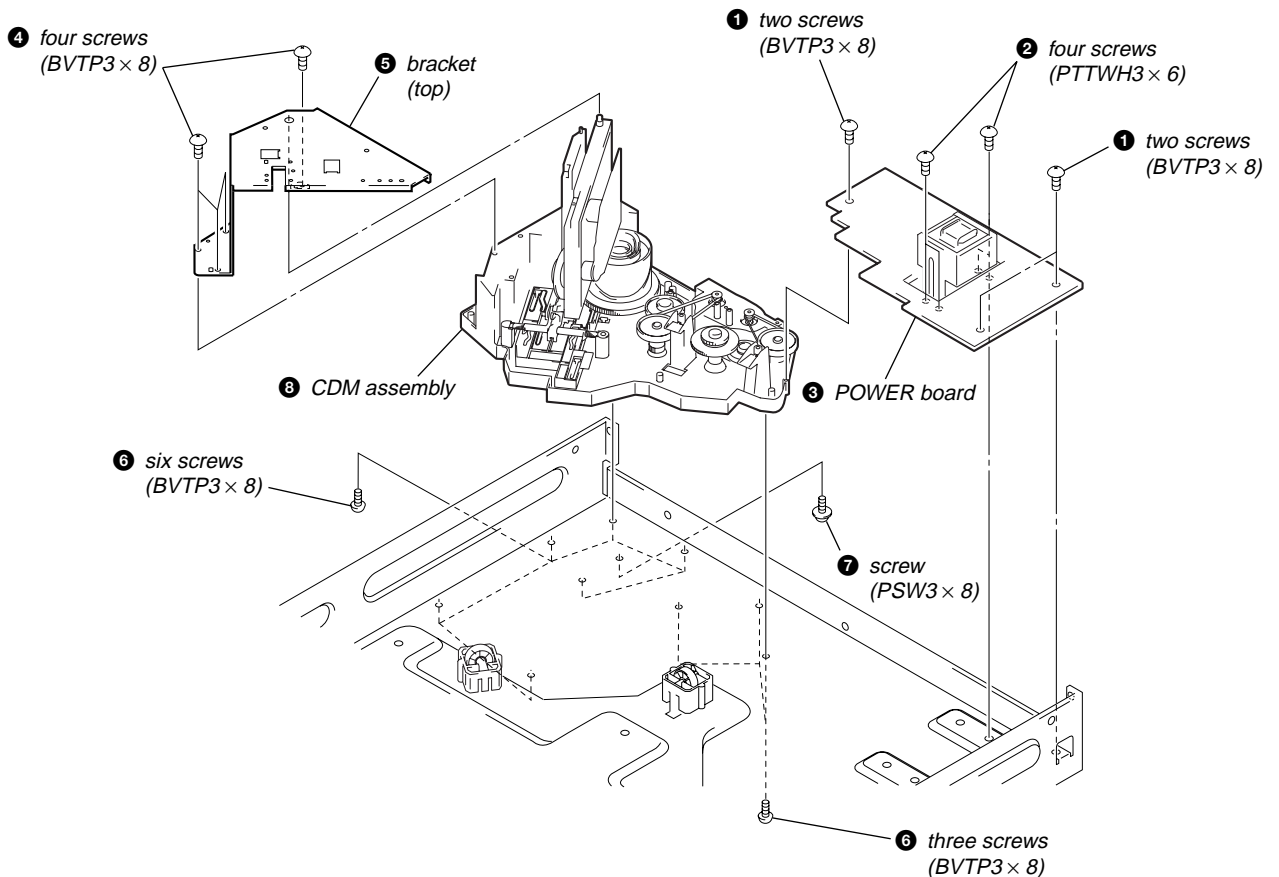

## SECTION 4 SERVICE MODE

### SPECIAL FUNCTION

This unit is provided with several service modes. Details are shown in the following table.

Mode name	Power supply state	Button operation	Remarks
ALL ERASE	OFF	[CLEAR] + [I/⏻]	Note 1
AGING MODE	ON	[GROUP 1] + [OPEN/CLOSE] + [+100]	
LOADING AGING MODE	ON	[GROUP 2] + [OPEN/CLOSE] + [+100]	
TABLE AGING MODE	ON	[GROUP 3] + [OPEN/CLOSE] + [+100]	
DOOR POP UP AGING MODE	ON	[GROUP 4] + [OPEN/CLOSE] + [+100]	
TABLE LOTATION MODE	ON	[GROUP 5] + [OPEN/CLOSE] + [+100]	Used in adjustment
TITLE MEMO SHIFT MODE	ON	[GROUP 7] + [OPEN/CLOSE] + [+100]	
MODEL NAME DISPLAY	ON	[GROUP 1] + [▶] + [+100]	
MICROPROCESSOR VERSION DISPLAY	ON	[GROUP 2] + [▶] + [+100]	
ALL LIT MODE	ON	[GROUP 3] + [▶] + [+100]	
MECHANISM ADJUSTMENT MODE	ON	[GROUP 4] + [▶] + [+100]	
SHIPMENT MODE	ON	[GROUP 5] + [▶] + [+100]	Note 1
TITLE MEMO RECORDING CHECK MODE	ON	[GROUP 6] + [▶] + [+100]	Note 1

#### Note 1

Do not execute unless with a proper reason, otherwise the memory of the title memo recorded by the customer will be erased. The title memo recording check mode is not required for servicing. Do not execute.

### ALL ERASE

This mode is used for clearing information such as the title memo. Do not execute if information such as the title memo is not to be erased.

#### Procedure:

While pressing the [CLEAR] button with the power OFF, press the [I/⏻] button and turn on the power. The fluorescent indicator tube displays "ALL ERASE" and all memories will be cleared.

### AGING MODE

- Mode which repeatedly changes and plays back discs automatically in the unit.
- It will repeat aging as long as no errors occur.
- If an error occurs during aging, it will stop all servos, motors, etc. instantaneously, display the error number, and stop operations. However, the stopping conditions differ according to whether the unit is equipped with the "self-protection function during errors" described later. The function serves to maintain the state of the unit when errors occur.

#### Sequence of Aging Mode

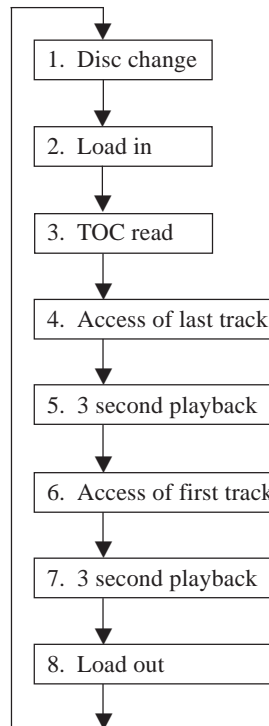

#### Order of Disc Change

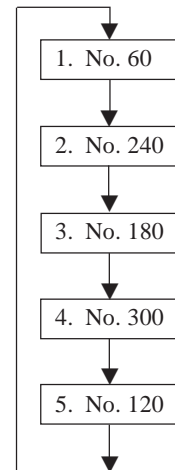

### Special Aging Mode Functions

The aging mode is provided with the following convenient functions

- Disc setting mode (\*1)
- Selection of presence of protection function during error (\*2)
- Count function of aging cycle (\*3)

\*1 Disc setting mode:

5 discs are set before setting the aging mode. This mode makes the setting of these discs more easy.

\*2 Self protection function during errors:

Function which voluntarily corrects errors which occur during normal operations by retries.

If this function is not provided, all operations will be stopped without retiring. It is suitable for checking errors with low reproducibility.

If this function is provided, and errors can be corrected by retries, aging will be continued without stopping.

\*3 Aging cycle count function:

Functions which displays the number of agings carried out on the Fluorescent indicator tube in numbers. One aging cycle consists of five discs.

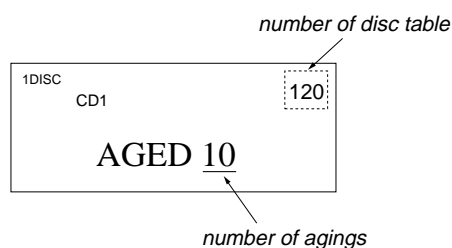

### Aging Procedure

1. Turn ON the power of the unit. Press the **OPEN/CLOSE** button and open the front cover.
2. Change the **COMMAND MODE** switch (S901) on set to **CD1**.
3. Press the **AGING START** button of the remote commander for aging mode (J-2501-123-A).
4. When the disc set mode is set, the **▶** and **■** LEDs blink.
5. Rotate the **DISC/CHARACTER** dial. The slits (No. 60, 120, 180, 240, 300) for setting the discs will come forward. Insert the discs into these slits. Do not set the discs in other slits.
6. Set whether the self-protection function during errors is equipped with the unit. Press the **REPEAT** button. If "REPEAT" is displayed on the fluorescent indicator tube, it means the function is provided. If "REPEAT" is not displayed, it means the function is not provided.

### Error Display

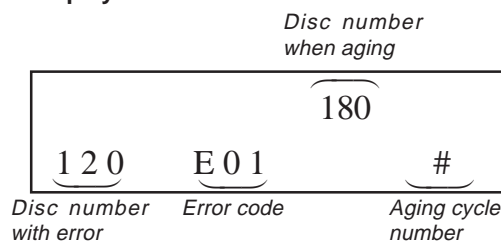

7. Press the **▶** button.
8. The **▶** LED blinks, the aging mode is set, and aging is started.
9. If errors occur during aging, the error number will be displayed on the fluorescent indicator tube. (Refer to the following table for the details of the errors.)
10. Aging will be repeated as long as no errors occur.
11. After each aging cycle, the number displayed on the fluorescent indicator tube will increase.
12. To release this mode, press the **I/O** button.

**Note:** As an alternative to steps 2 and 3, press the **GROUP 1** button, **OPEN/CLOSE** button, and **+100** button at the same time.

### Error code

Code number	Name	Contents
Err 01	DISC sensor check 1	No disc in the specified slit
Err 02	DISC sensor check 2	Disc in other slits
Err 03	Table operation check 1	Table motor current over
Err 04	Table operation check 2	No table sensor input
Err 05	Loading operation check 1	Load in timeover
Err 06	Loading operation check 2	Load out timeover
Err *1	BU related check 1	Access timeover
Err *2	BU related check 2	High speed search NG
Err *3	BU related check 3	Q data read error
Err *4	BU related check 4	BU operation (from focus search to until signal can be read) timeover
Err *5	BU related check 5	GFS monitor error
Err *6	BU related check 6	Focus cannot be imposed by focus search
Err *7	BU related check 7	Auto focus bias adjustment cannot be performed

The \* numbers mean the following according to the state of the unit during aging

- 2 : From chucking to end of TOC read
- 3 : From end of TOC read to end of last track playback
- 4 : From end of last track playback to end of first track playback

## LOADING AGING MODE

- This mode is used for repeating loading operations continuously.
- Aging will be performed continuously unless an error occurs.
- When an error occurs, the error code will be displayed on the fluorescent indicator tube.

### Procedure:

1. Set a disc in the DISC 1 slit.
2. With the power ON, while pressing the **GROUP 2** button and **OPEN/CLOSE** button, press the **+100** button.
3. When the mode is set, both the **▶** and **■** indicators will start to blink.
4. When the **▶** button is pressed, only the **▶** indicator will blink and aging starts.
5. To release the mode, press the **I/O** button.

The error codes displayed during operations and when errors occur are the same as the “AGING MODE” described earlier.

## TABLE AGING MODE

- This mode is used for rotating the table randomly.
- Aging will be performed continuously unless an error occurs.
- When an error occurs, the error code will be displayed on the fluorescent indicator tube.

### Procedure:

1. Set discs in slits 1, 2, 99, 100, and 200.
2. With the power ON, while pressing the **GROUP 3** button and **OPEN/CLOSE** button, press the **+100** button.
3. When the mode is set, both the **▶** and **■** indicators will start to blink.
4. When the **▶** button is pressed, only the **▶** indicator will blink and aging starts.
5. To release the mode, press the **I/O** button.

During aging, operations will be carried out sequentially in the order of No. 1, No. 2, No. 100, No. 99, and No. 200 slits.

The error codes displayed during operations and when errors occur are the same as the “AGING MODE” described earlier.

## DOOR POP UP AGING MODE

- This mode is used for performing aging of the CD pop up part and door open/close.

It is used for checking if operations are performed normally.

### Procedure:

1. To select a slot to be aged, press the **OPEN/CLOSE** button and rotate the **DISC/CHARACTER** knob with the front door opened to select a number.
2. With the power ON, while pressing the **GROUP 4** button and **OPEN/CLOSE** button, press the **+100** button.
3. When the **▶** button is pressed, aging starts, and door open/close and up/down operations of the pop up part are performed continuously.
4. To release the mode, press the **I/O** button.

The number of times aging is performed will be displayed on the fluorescent indicator tube during operations.

## TABLE ROTATION MODE

- This mode is used for electrical adjustments. Refer to the section on Electrical Adjustments.

## TITLE MEMO SHIFT MODE

- This mode is used for writing title memo information recorded in this unit in a different unit.  
Use it for transferring disc memo contents written by the customer to the new units when replacing the unit, etc.

### Connection:

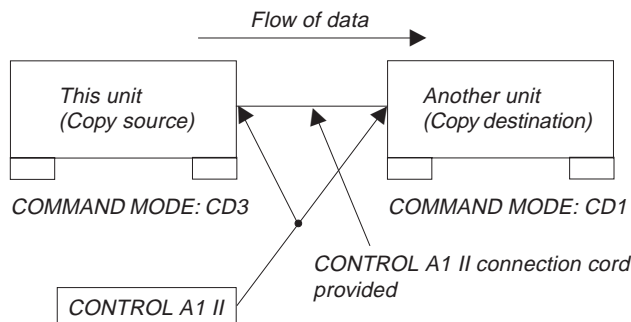

### Procedure:

1. Connect two units using the **CONTROL A1 II** connection cord shown in the figure.
2. Set the **COMMAND MODE** switch of the copy source unit to **CD3** and the **COMMAND MODE** switch of the copy destination unit to **CD1**.
3. With the power on, while pressing the **GROUP 7** button and **OPEN/CLOSE** button of the copy destination unit, press the **+100** button.
4. When the data has been transferred, the fluorescent indicator tube displays “complete” for about 1 second.

## MODEL NAME DISPLAY

- Model names can be displayed on the fluorescent indicator tube for checking the microprocessor model setting, etc.

### Procedure:

With the power ON, while pressing the **GROUP 1** and **▶** buttons, press the **+100** button.  
The model name is displayed on the fluorescent indicator tube.

## MICROPROCESSOR VERSION DISPLAY

- The microprocessor version can be displayed on the fluorescent indicator tube.

### Procedure:

With the power ON, while pressing the **GROUP 2** and **▶** buttons, press the **+100** button.  
The microprocessor version is displayed on the fluorescent indicator tube.

## ALL LIT MODE

- This mode is used for lighting the whole fluorescent indicator tubes and LEDs.

### Procedure:

With the power ON, while pressing the **GROUP 3** and **▶** buttons, press the **+100** button.  
Both the fluorescent indicator tubes and LEDs will light up completely.  
To release this mode, press the **I/O** mode.

### **MECHANISM ADJUSTMENT MODE**

- This mode is used for mechanism adjustments. Refer to the section on Mechanism Adjustments.

### **SHIPMENT MODE**

- This mode is used for setting the unit to the shipment state. Do not execute it without a proper reason as it erases the memory of the title memo recorded by the customer.

#### **Procedure:**

Set the **COMMAND MODE** switch to **CD1** and the **TIMER** switch to **OFF**. Next, with the power ON, while pressing the **GROUP 5** button and **▷** button, press the **+100** button. If the switch state is normal, the model name will be displayed on the fluorescent indicator tube and the unit will set into the shipment mode.

If the various switches are not set to their designated positions, error codes will be displayed on the fluorescent indicator tube.

### **TITLE MEMO RECORDING CHECK MODE**

This mode is not required for servicing. Do not execute without a proper reason.

If executed, the memory of the title memo recorded by the customer will be erased.

## SECTION 5 TEST MODE

### 5-1. ADJ MODE

1. Turn ON the power of the unit, set disc to disc table, and perform chucking.
2. Remove the power cord from the outlet.
3. To set ADJ mode, connect the ⑥1 pin of IC501 (ADJ) of the MAIN board to ground, and connect the power cord to the outlet.

In this mode, table rotation and loading operations are not performed because it is taken that the disc has already been chucked.

- Note:** The same operations are also performed in the following when the ⑥1 pin of IC501 (ADJ) is connected to ground after turning on the power.
- Direct search (movement of sledding motor) is not performed during accessing
  - Ignored even when GFS becomes L
  - Ignored even when the Q data cannot be read
  - Focus gain does not decrease

#### ADJ Mode Special Functions Table

Button	Function
CONTINUE	Servo average display Displays VC, FE, RF, TE and traverse in hexadecimal numbers
SHUFFLE	Focus bias display Each time this is pressed, the focus bias is switched between 1 and 2 (1) Bias actually set    Optimum bias    Minimum jitter (2) U:Upper aliasing bias    L:Lower aliasing bias
PROGRAM	Auto gain display Displays focus, tracking, sledding in hexadecimal numbers
GROUP 3 (3)	Turns off the tracking and sledding servo
GROUP 8 (8)	Turns on the tracking and sledding servo
CHECK	S-curve observation mode. (Release this mode when the I/c button is pressed.)

#### • Checking Location

##### – MAIN BOARD (Conductor Side) –

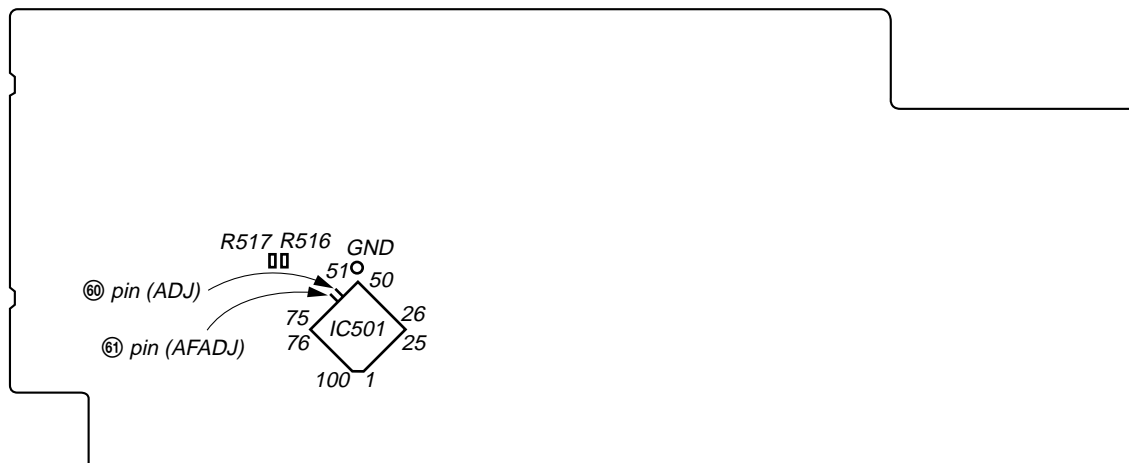

### 5-2. KEY AND DISPLAY CHECK MODE

To set this mode, connect the ⑥0 pin of IC501 (AFADJ) on the MAIN board to ground, and connect the power cord to the outlet.

- Note:** When this mode is executed, all title memos recorded will be erased.
- When this button is pressed, "line # No. #" will be displayed. However, these will not be displayed for the following special buttons. However, these will not be displayed for the following special buttons.

■ (stop) button : FL segment check  
(Refer to FL Tube Check Patterns)

▨ (pause) button : FL grid check  
(Refer to FL Tube Check Patterns)  
The ▨ LED also lights up simultaneously.

▷ (play) button : All FL segment and grid will light up.  
▷ LED also lights up simultaneously.

TIMER switch : When the switch position is **PLAY**, the **STANDBY** LED lights up. It goes OFF when set to **OFF**.

Each time this button is pressed, the value of the "Go+ ## keys" increases. Buttons pressed once will not be counted when pressed again.

#### FL Tube Check Patterns

Segment check



Grid check

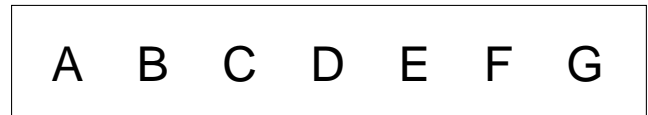

- When the jog dial is rotated to the right, the GROUP LEDs light up in the order of 1→2..8→HIT LIST→EASY PLAY→MEGA CONTROL→1.
- When the jog dial is rotated to the left, the GROUP LEDs light up in the order of 8→7..1→MEGA CONTROL→EASY PLAY→HIT LIST→8.

• Abbreviation

FL: Fluorescent Indicator Tube



## SECTION 6 MECHANICAL ADJUSTMENTS

### POP UP MECHANISM ADJUSTMENT

1. With the power ON, while pressing the **GROUP 4** and  buttons, press the **+100** button to enter the mechanism adjustment mode.
2. Press the **GROUP 1** button to operate the loading mechanism, and continue pressing until the disc table locks. (Fig-1)
3. Press the **GROUP 2** button to raise the pop up part.
4. Remove the cover (chassis), loosen the adjusting screw, move the screwdriver left and right until the lever (POP UP) does not touch the slit wall, and secure the screw. (Fig-2)

The following buttons have special functions in this mode.

- GROUP 1** button: Loading mechanism IN operation
- GROUP 5** button: Loading mechanism OUT operation
- GROUP 2** button: Pop up part UP operation
- GROUP 6** button: Pop up part DOWN operation

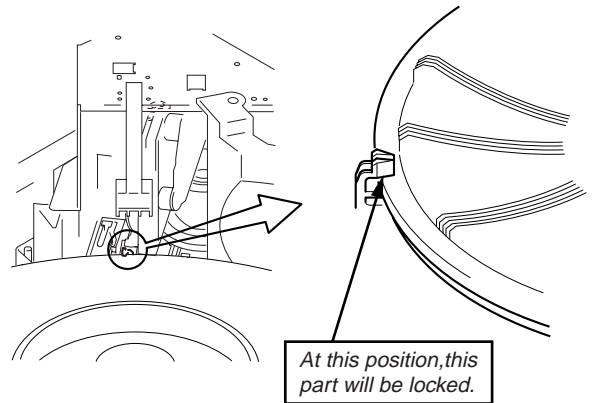
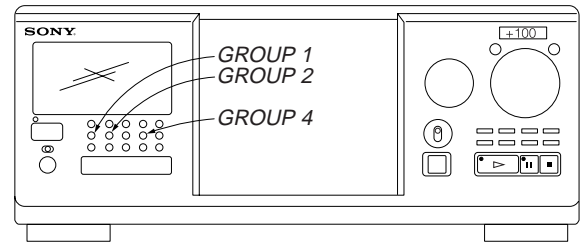

**Fig-1**

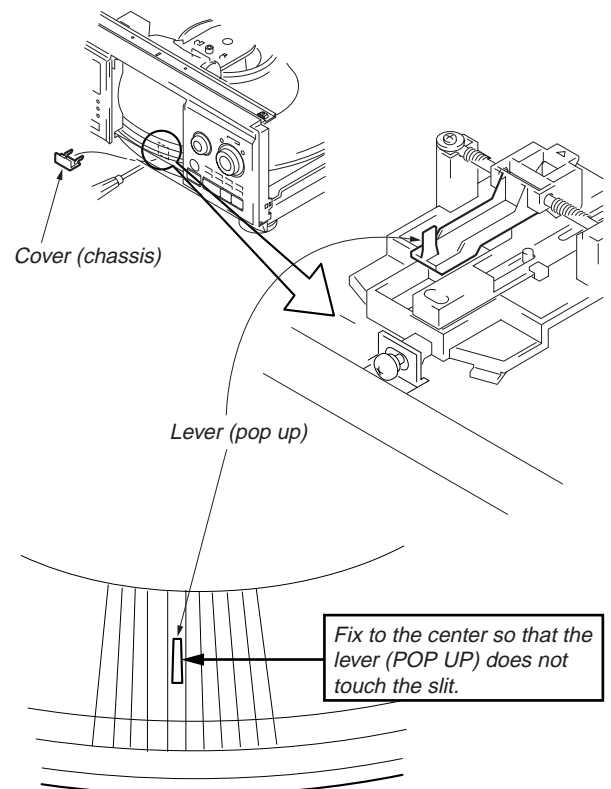

**Fig-2**

## SENSOR ADJUSTMENT

1. With the power ON, while pressing the **GROUP 4** and **▶** buttons, press the **+100** button to enter the mechanism adjustment mode.
2. Press the **GROUP 1** button to operate the loading mechanism, and continue pressing until the disc table locks. (Fig-3)
3. Loosen the fixing screw, move the holder (TABLE SENSOR) slightly, and when the LED (green) of the **▶** button switches to the LED (orange) of the **■** button (or vice versa), secure the holder (TABLE SENSOR). (Fig-4)
4. Moving the disc table right and left with a hand after the screw is fixed, the table will move by the play of a disc table. If the LEDs light up alternately, the adjustment will be performed correctly. (Fig-4)

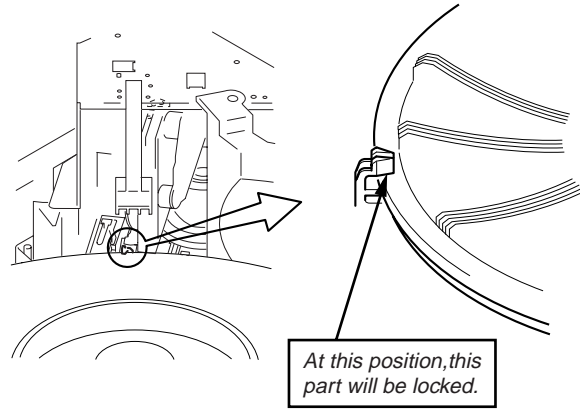
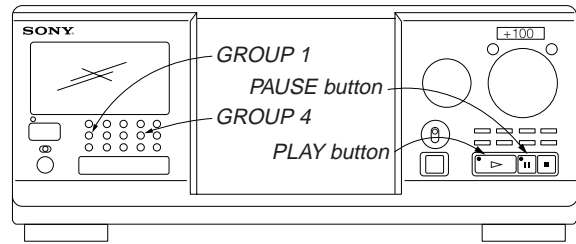

**Fig-3**

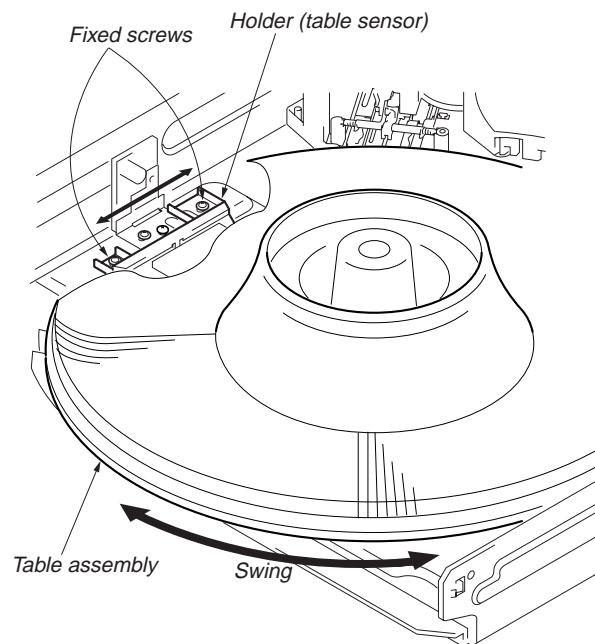
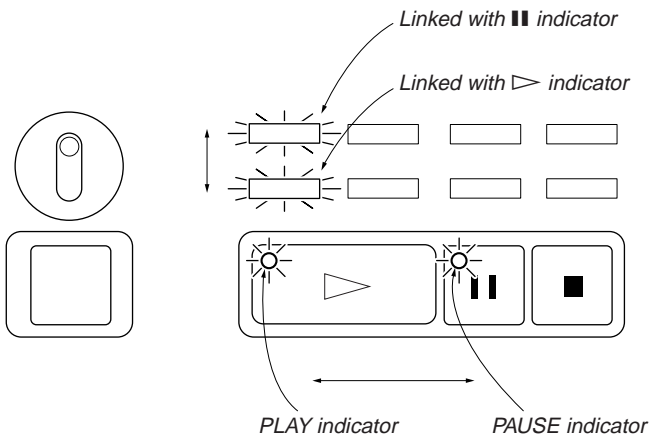
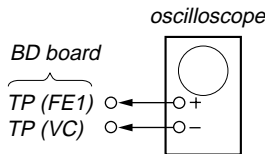

**Fig-4**

## SECTION 7 ELECTRICAL ADJUSTMENT

1. CD Block is basically designed to operate without adjustment. Therefore, check each item in order given.
2. Use YEDS-18 disc (3-702-101-01) unless otherwise indicated.
3. Use an oscilloscope with more than 10 MΩ impedance.
4. Clean the object lens by an applicator with neutral detergent when the signal level is low than specified value with the following checks.

### S-Curve Check



#### Procedure :

1. Chuck the disc (YEDS-18) beforehand, and remove the power cord from the outlet.
2. Connect oscilloscope to test point TP (FE1) on BD board.
3. Connect ⑨ pin of IC501 (ADJ) on MAIN board to ground with lead wire.
4. The ADJ mode is set when the power cord is inserted into the outlet and power is supplied.
5. The fifth track is played automatically.
6. Press the **CHECK** button.
7. Check the oscilloscope waveform (S-curve) is symmetrical between A and B. And confirm peak to peak level within  $3 \pm 1$  Vp-p.

S-curve waveform

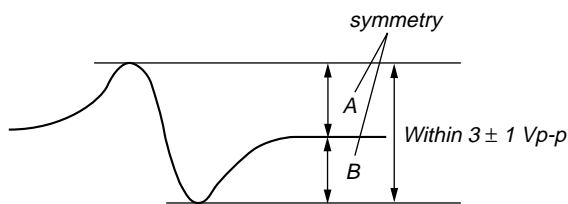

8. Pressing the **I/O** button stops the output of the waveform (s curve).
  9. After check, disconnect the lead wire connected in step 3.
- Note :**
- Try to measure several times to make sure than the ratio of A : B or B : A is more than 10 : 7.
  - Take sweep time as long as possible and light up the brightness to obtain best waveform.

**Adjustment Location:** BD board

### RF Level Check

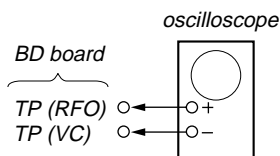

#### Procedure :

1. Connect oscilloscope to test point TP (RFO) on BD board.
2. Turn Power ON.
3. Put disc (YEDS-18) in to play the number five track.
4. Confirm that oscilloscope waveform is clear and check RF signal level is correct or not.

**Note:** A clear RF signal waveform means that the shape “◇” can be clearly distinguished at the center of the waveform.

RF signal waveform

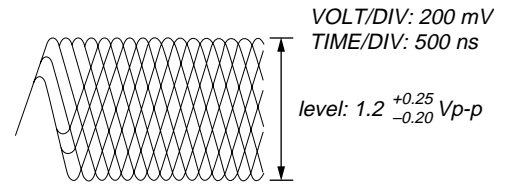

**Adjustment Location:** BD board

### E-F Balance Check

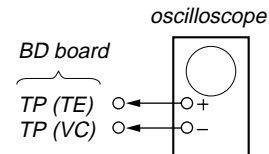

#### Procedure :

1. Chuck the disc (YEDS-18) beforehand, and disconnect the power cord from the outlet.
2. Connect oscilloscope to test point TP (TE) on BD board.
3. Connect ⑨ pin of IC501 (ADJ) on MAIN board to ground with lead wire.
4. The ADJ mode is set when the power cord is inserted into the outlet and power is supplied.
5. The fifth track is played automatically.
6. Press the **GROUP 3** button. (The tracking servo and the sledging servo are turned OFF.)
7. Check the level B of the oscilloscope waveform and the A (DC voltage) of the center of the Traverse waveform. Confirm the following :  
 $A/B \times 100 = \text{less than } \pm 22\%$

Traverse waveform

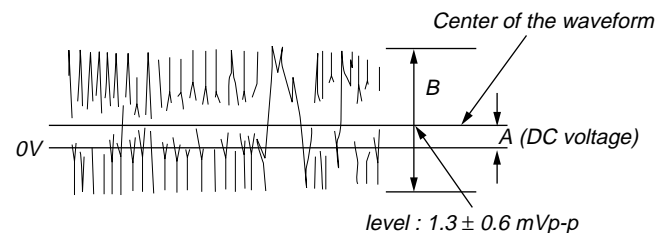

8. Press the **GROUP 8** button. (The tracking servo and sledging servo are turned ON.) Confirm the C (DC voltage) is almost equal to the A (DC voltage) is step 7.

Traverse waveform

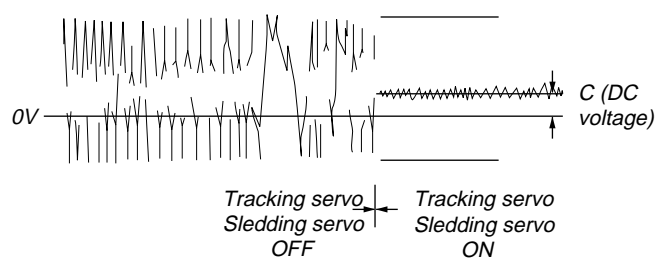

9. Disconnect the lead wire connected in step 3.

**Adjustment Location:** MAIN board

### Disc In Detect Sensor Adjustment

Be sure to perform this adjustment after sensor adjustment in MECHANICAL ADJUSTMENT.

#### Connection:

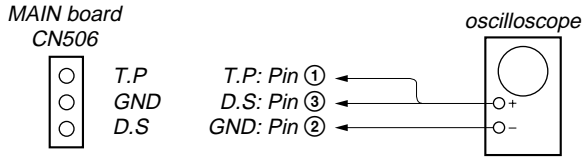

#### Waveform:

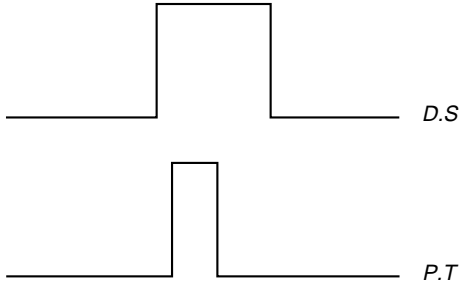

1. Connect the oscilloscope to Pins ①, ②, and ③ of CN506 of the MAIN board.
2. Check that no discs are loaded in the unit.
3. With the power ON, while pressing the **[GROUP 5]** and **[OPEN/CLOSE]** buttons, press the **[+100]** button. The disc table starts to rotate in the clockwise direction.
4. Loosen the fixing screw, move the mounting board (SENSOR), and secure the mounting board (SENSOR) at the point the H portion of the P.T waveform comes the center of the H portion of the D.S waveform.

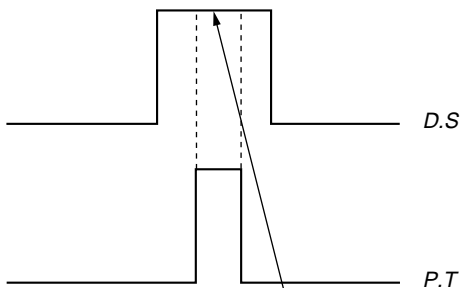
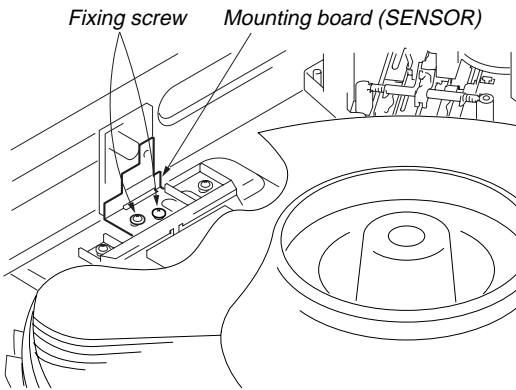

5. Rotate the **[DISC/CHARACTER]** knob in the counterclockwise direction and the disc table starts to rotate in the same direction. Check that the waveform at this time is the same as that in step 4. If larger by a considerable extent, rotate the **[DISC/CHARACTER]** knob in the clockwise direction and the disc table starts to rotate in the same direction. Repeat from step 4.
6. Rotate RV501 of the MAIN board and adjust so that the H and L portions of the D.S waveform become the same.

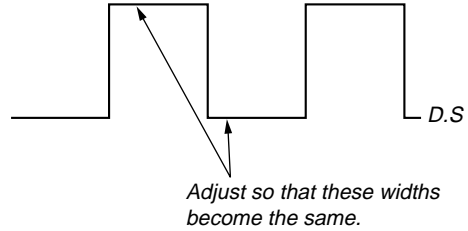

Adjustment Location: MAIN board

#### • Adjustment Location

– BD BOARD (Conductor Side) –

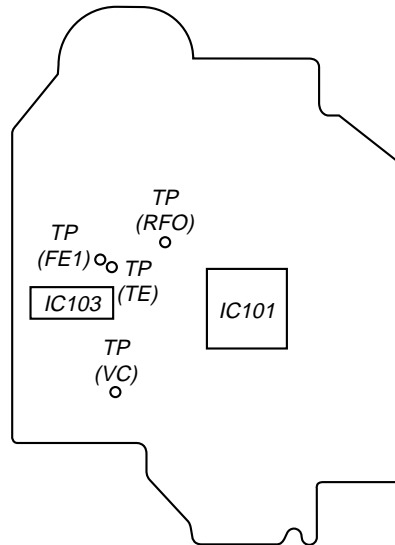

– MAIN BOARD (Component Side) –

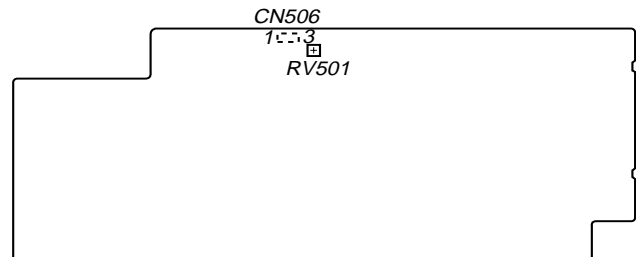

SECTION 8  
DIAGRAMS

8-1. BLOCK DIAGRAM - BD Section -

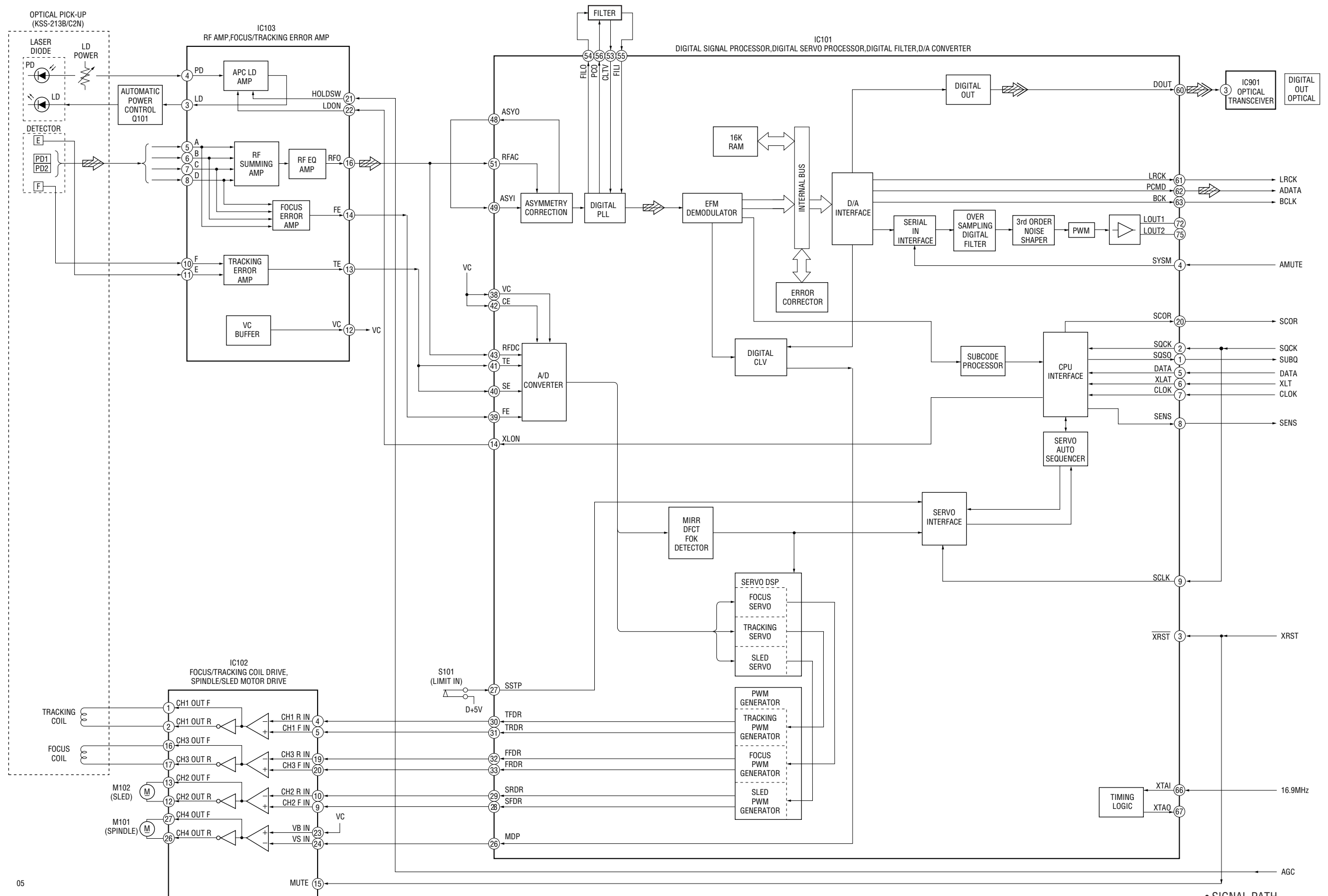

• SIGNAL PATH  
 : CD PLAY (ANALOG OUT)  
 : CD PLAY (DIGITAL OUT)

**A**  
 MAIN SECTION  
 (Page 22)

8-2. BLOCK DIAGRAM - MAIN Section -

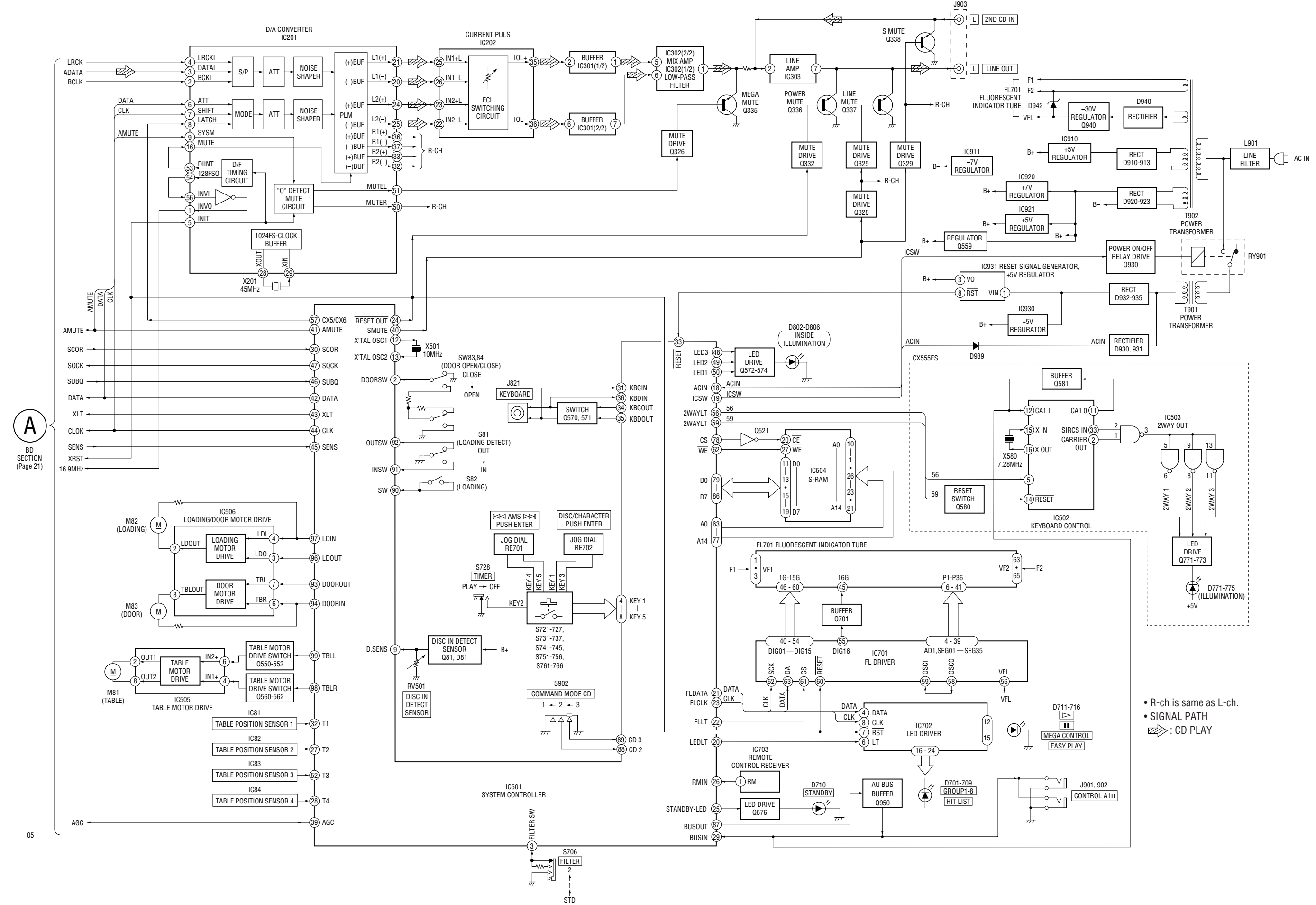

A  
BD SECTION  
(Page 21)

• R-ch is same as L-ch.  
• SIGNAL PATH  
⇒ : CD PLAY

### 8-3. NOTE FOR PRINTED WIRING BOARDS AND SCHEMATIC DIAGRAMS

#### Note on Printed Wiring Board:

- : parts extracted from the component side.
- : parts extracted from the conductor side.
- : parts mounted on the conductor side.
- ▨ : Pattern from the side which enables seeing. (The other layers' patterns are not indicated.)

#### Caution:

Pattern face side: Parts on the pattern face side seen from the pattern face are indicated.  
 (Conductor Side)  
 Parts face side: Parts on the parts face side seen from the parts face are indicated.  
 (Component Side)

- Indication of transistor.

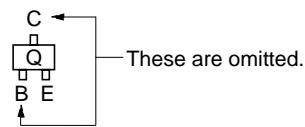
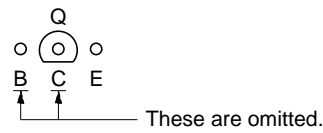
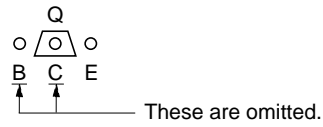

#### Note on Schematic Diagram:

- All capacitors are in  $\mu\text{F}$  unless otherwise noted. pF:  $\mu\text{F}$  50 WV or less are not indicated except for electrolytics and tantalums.
- All resistors are in  $\Omega$  and  $1/4\text{W}$  or less unless otherwise specified.
- $\Delta$  : internal component.
- $\square$  : panel designation.

#### Note:

The components identified by mark  $\Delta$  or dotted line with mark  $\Delta$  are critical for safety. Replace only with part number specified.

#### Note:

Les composants identifiés par une marque  $\Delta$  sont critiques pour la sécurité. Ne les remplacer que par une pièce portant le numéro spécifié.

- $\text{B}+$  : B+ Line.
- $\text{B}-$  : B- Line.
- $\square$  : adjustment for repair.
- Voltages and waveforms are dc with respect to ground under no-signal conditions. no mark : CD PLAY
- Voltages are taken with a VOM (Input impedance 10 M $\Omega$ ). Voltage variations may be noted due to normal production tolerances.
- Waveforms are taken with a oscilloscope. Voltage variations may be noted due to normal production tolerances.
- Circled numbers refer to waveforms.
- Signal path.
  - ⇒ : CD PLAY (ANALOG OUT)
  - ⇒ : CD PLAY (DIGITAL OUT)

### • Circuit Boards Location

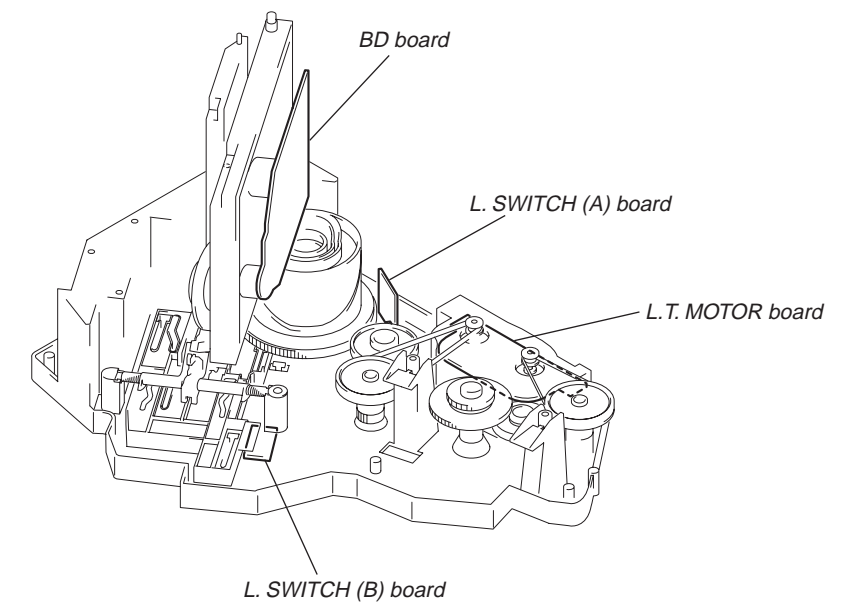
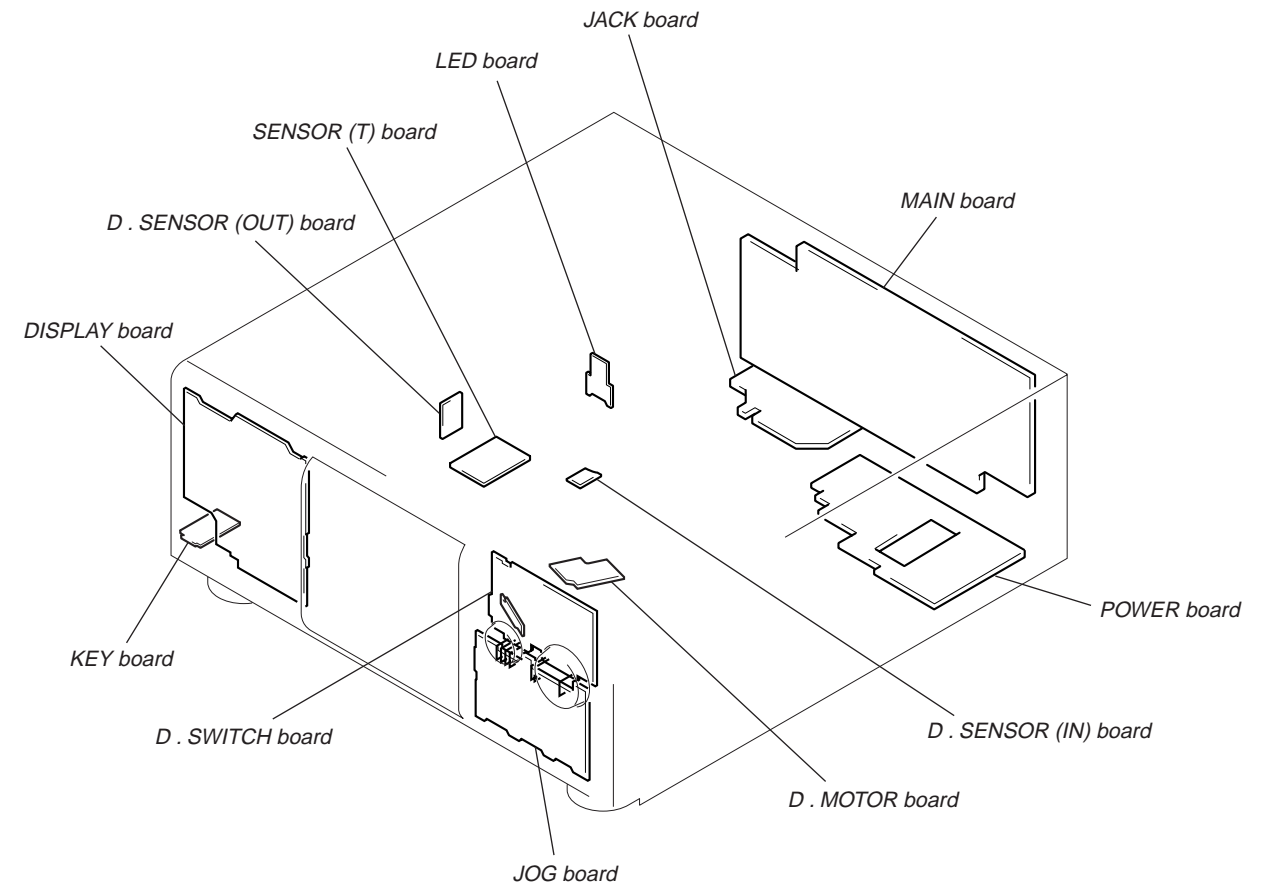

8-4. PRINTED WIRING BOARD – BD Board – • See page 23 for Circuit Boards Location.

【BD BOARD】(COMPONENT SIDE)

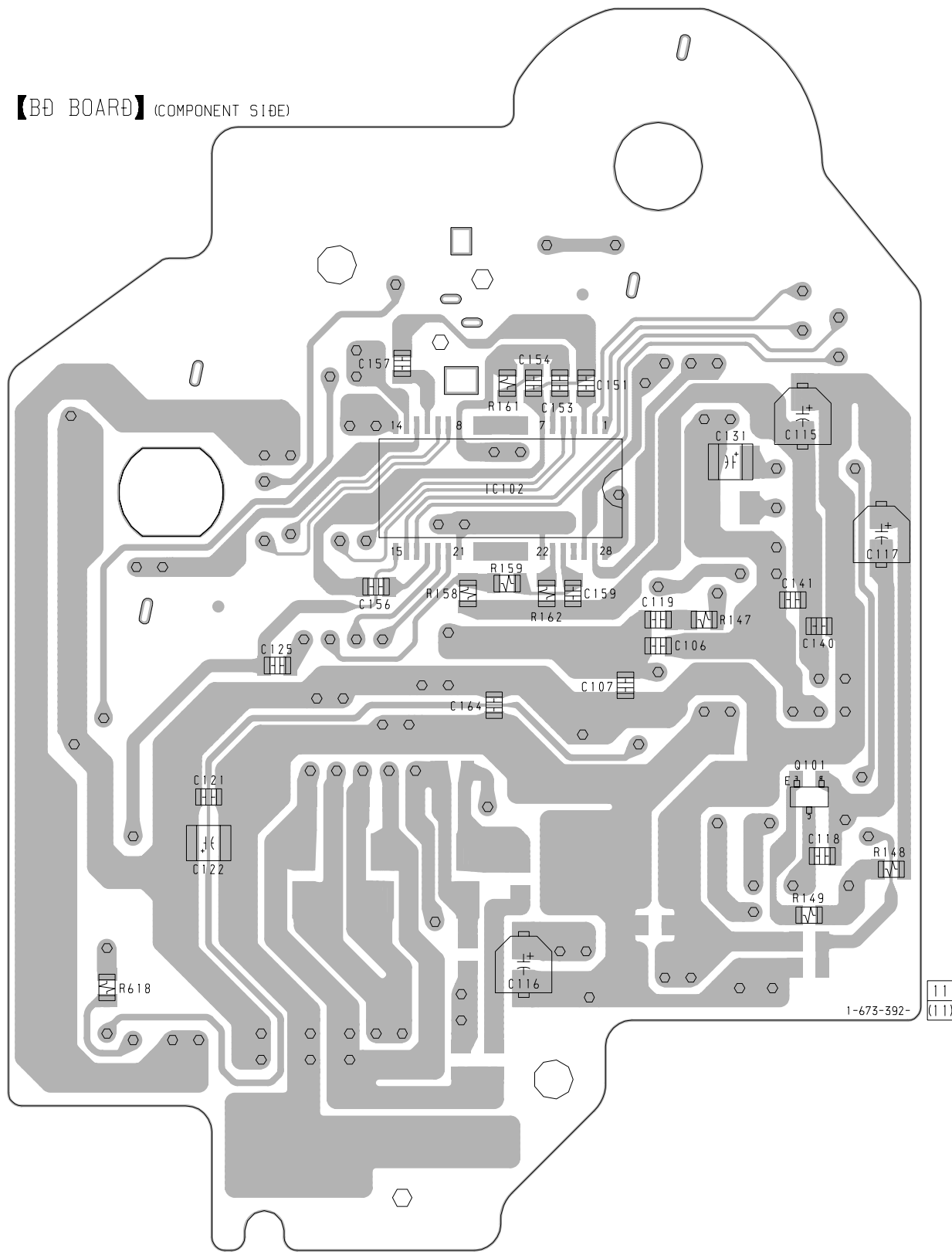

【BD BOARD】(CONDUCTOR SIDE)

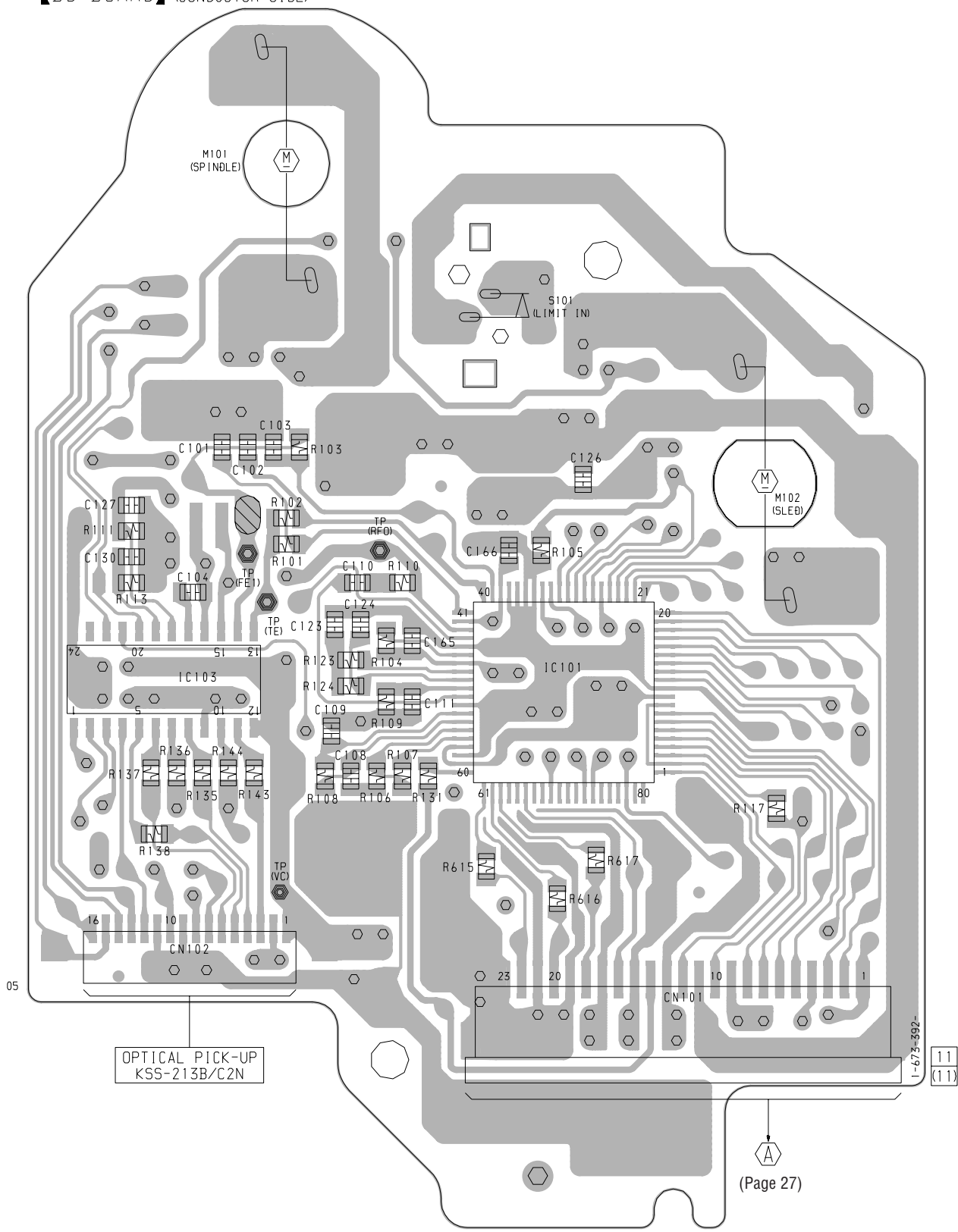



8-5. SCHEMATIC DIAGRAM – BD Board – • See page 42 for Waveforms. • See page 44 for IC Block Diagrams.

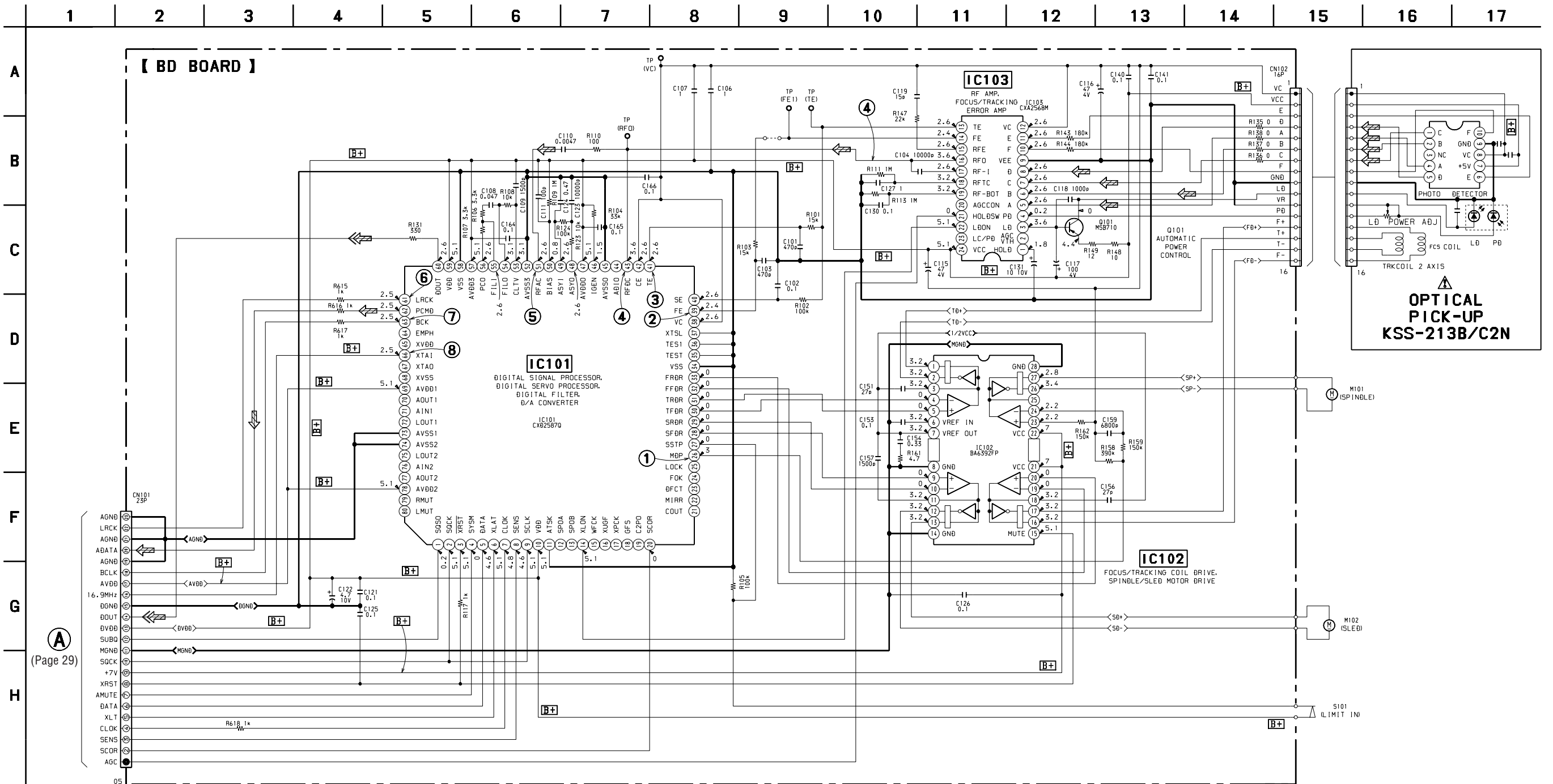

(Page 29)

The components identified by mark  $\Delta$  or dotted line with mark  $\Delta$  are critical for safety. Replace only with part number specified.

Les composants identifiés par une marque  $\Delta$  sont critiques pour la sécurité. Ne les remplacer que par une pièce portant le numéro spécifié.

8-6. PRINTED WIRING BOARD – MAIN Board – • See page 23 for Circuit Boards Location.

【MAIN BOARD】(COMPONENT SIDE)

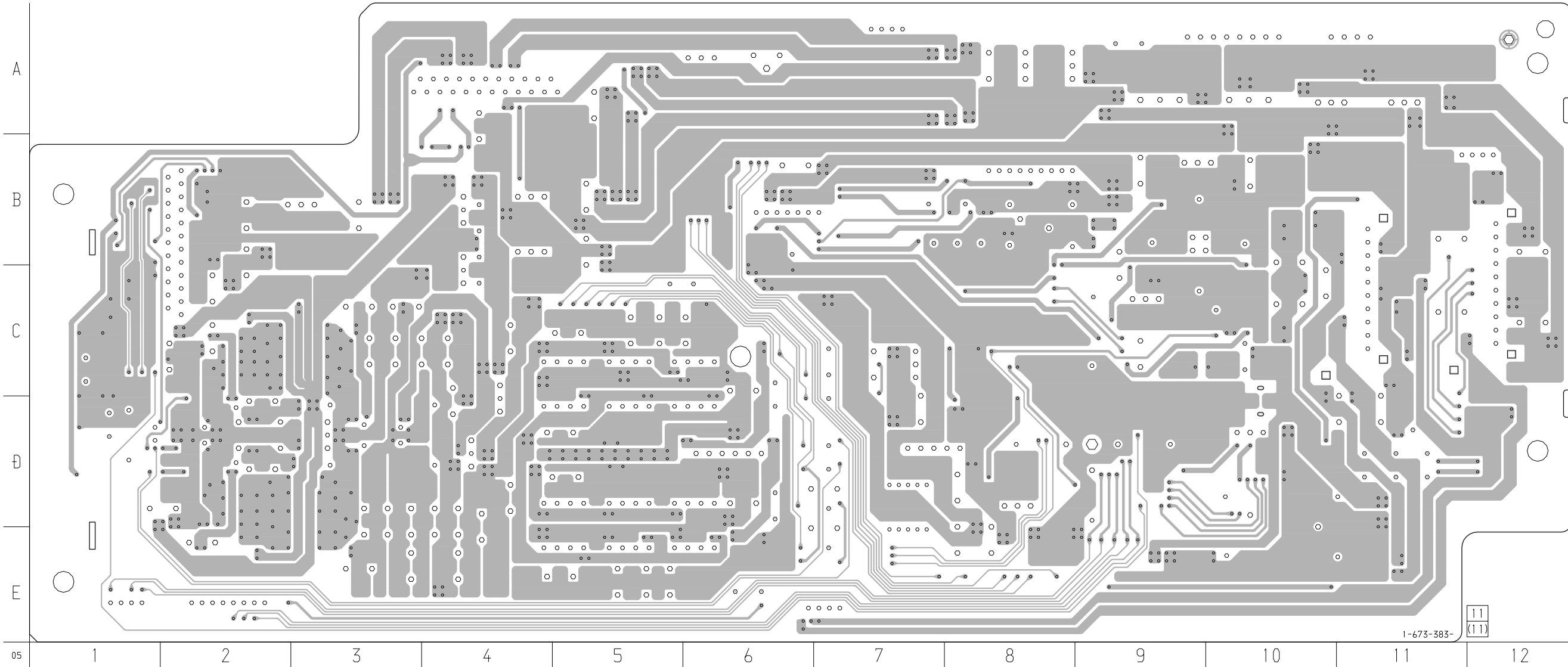

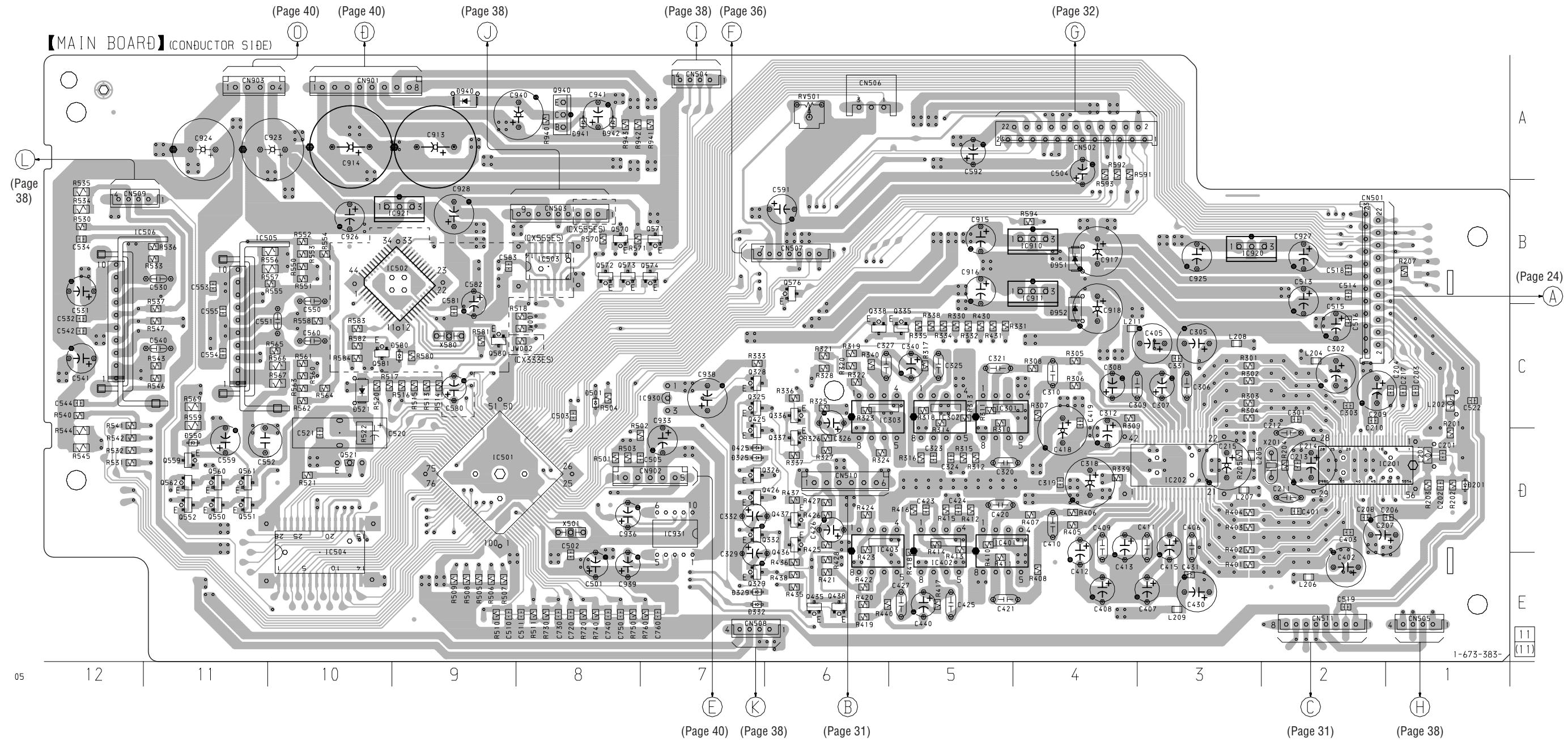

• Semiconductor Location

Ref. No.	Location	Ref. No.	Location	Ref. No.	Location	Ref. No.	Location	Ref. No.	Location
D201	D-1	IC201	D-2	IC910	B-4	Q337	D-6	Q561	D-11
D325	D-7	IC202	D-3	IC911	B-4	Q338	C-6	Q562	D-11
D329	E-7	IC301	C-5	IC920	B-3	Q425	D-7	Q570	B-8
D332	E-7	IC302	C-5	IC921	B-9	Q426	D-7	Q571	B-7
D425	D-7	IC303	C-6	IC930	C-7	Q435	E-6	Q572	B-8
D501	C-8	IC401	D-5	IC931	D-7	Q436	D-6	Q573	B-8
D521	C-10	IC402	D-5			Q437	D-6	Q574	B-7
D550	D-11	IC403	D-6	Q325	C-7	Q438	E-6	Q576	B-6
D580	C-9	IC501	D-9	Q326	D-7	Q521	D-10	Q580	C-9
D940	A-9	IC502	B-9	Q328	C-7	Q550	D-11	Q581	C-10
D941	A-8	IC503	B-8	Q329	E-7	Q551	D-11	Q940	A-8
D942	A-8	IC504	D-10	Q332	D-7	Q552	D-11		
D951	B-4	IC505	C-11	Q335	C-5	Q559	D-11		
D952	C-4	IC506	C-12	Q336	C-6	Q560	D-11		

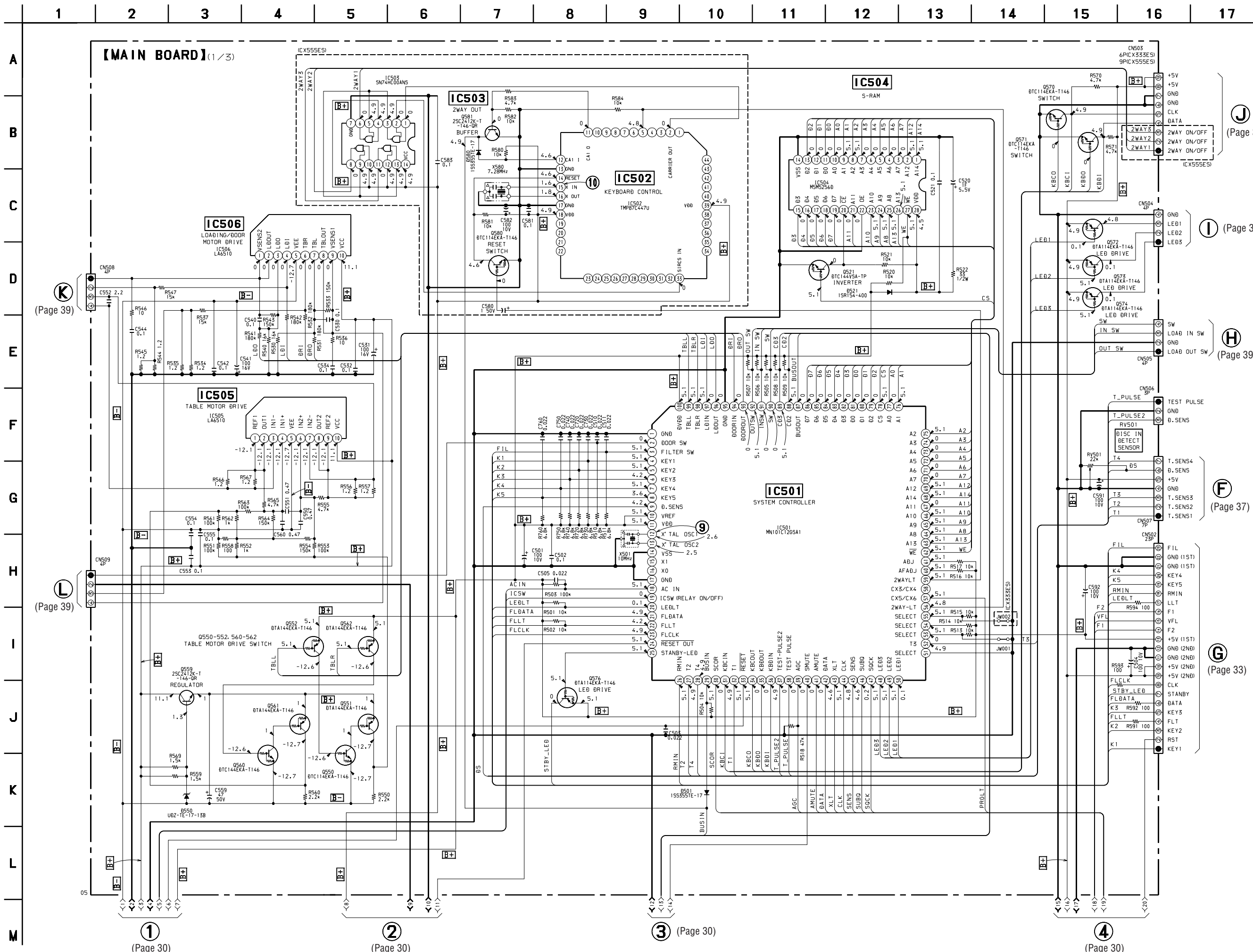

① (Page 30)

② (Page 30)

③ (Page 30)

④ (Page 30)

J (Page 39)

I (Page 39)

H (Page 39)

F (Page 37)

G (Page 33)

8-8. SCHEMATIC DIAGRAM – MAIN Board (2/3) – • See page 42 for Waveforms. • See page 46 for IC Block Diagrams.

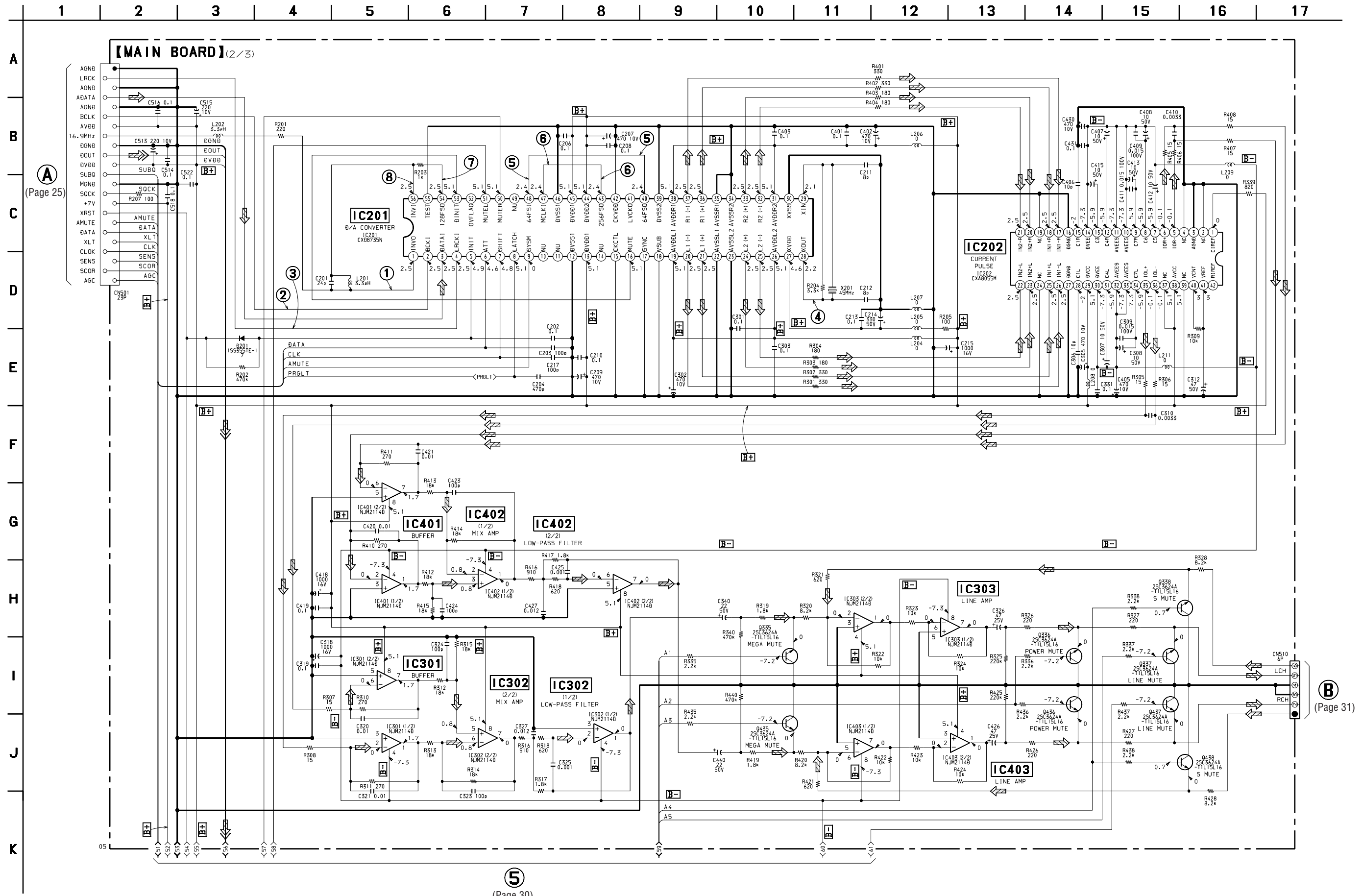

(Page 25)

5 (Page 30)

B (Page 31)

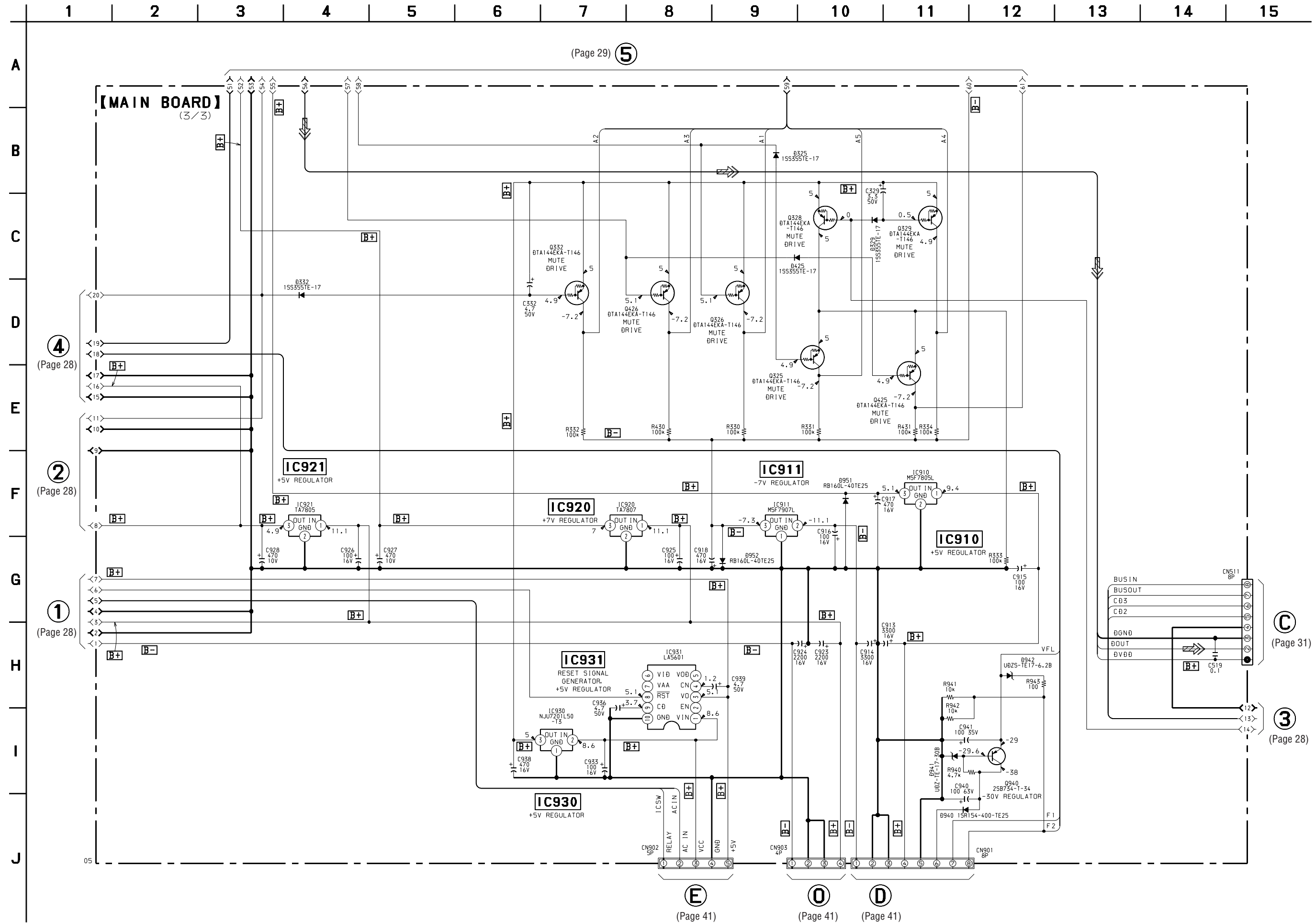

(Page 29) 5

4 (Page 28)

2 (Page 28)

1 (Page 28)

C (Page 31)

3 (Page 28)

E (Page 41)

O (Page 41)

D (Page 41)

8-10. PRINTED WIRING BOARD – JACK Board – • See page 23 for Circuit Boards Location.

8-11. SCHEMATIC DIAGRAM – JACK Board –

【 JACK BOARD 】

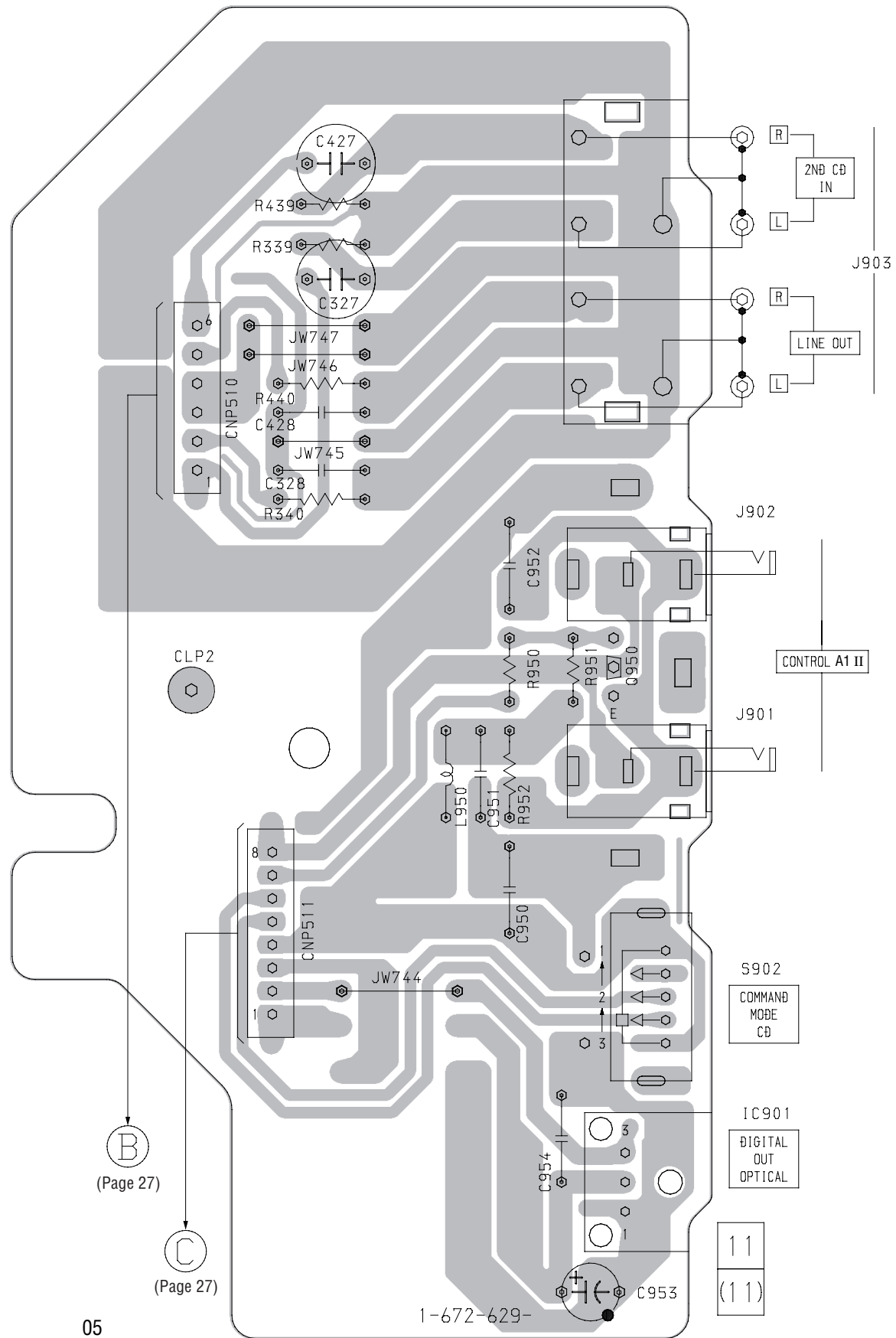

(B)  
(Page 27)

(C)  
(Page 27)

05

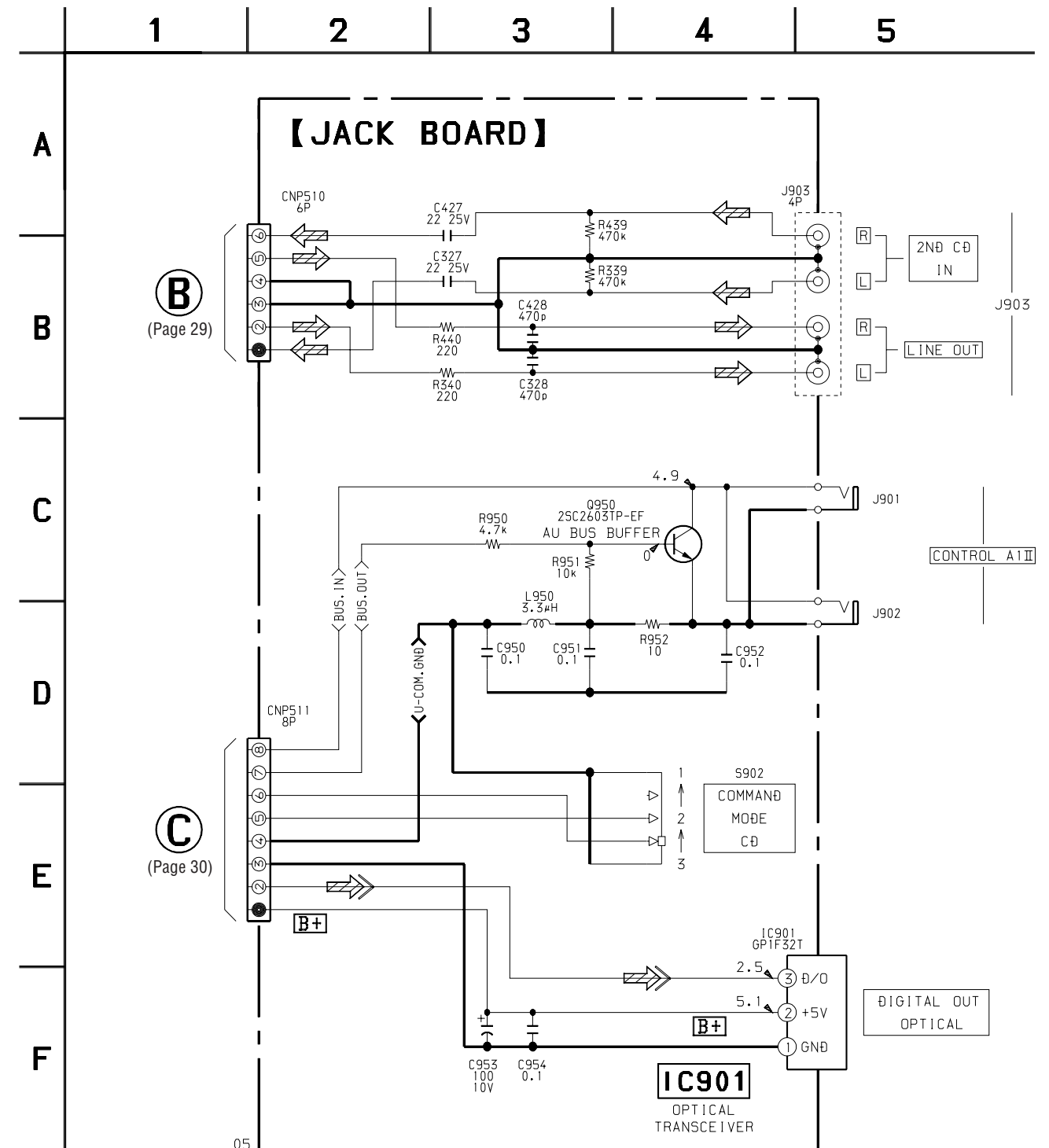

(B)  
(Page 29)

(C)  
(Page 30)

8-12. PRINTED WIRING BOARD – DISPLAY Board – • See page 23 for Circuit Boards Location.

(Page 34)

(Page 27)

【 DISPLAY BOARD 】

• Semiconductor Location

Ref. No.	Location
D701	D-4
D702	D-3
D703	D-2
D704	D-1
D705	E-4
D707	E-3
D708	E-2
D709	E-2
D710	C-5
D771	E-1
D772	E-2
D773	E-3
D774	E-4
D775	E-2
D780	F-1
D781	F-3
D782	F-2
IC701	B-2
IC702	C-1
IC703	A-2
Q701	C-3
Q771	F-2
Q772	F-3
Q773	F-2

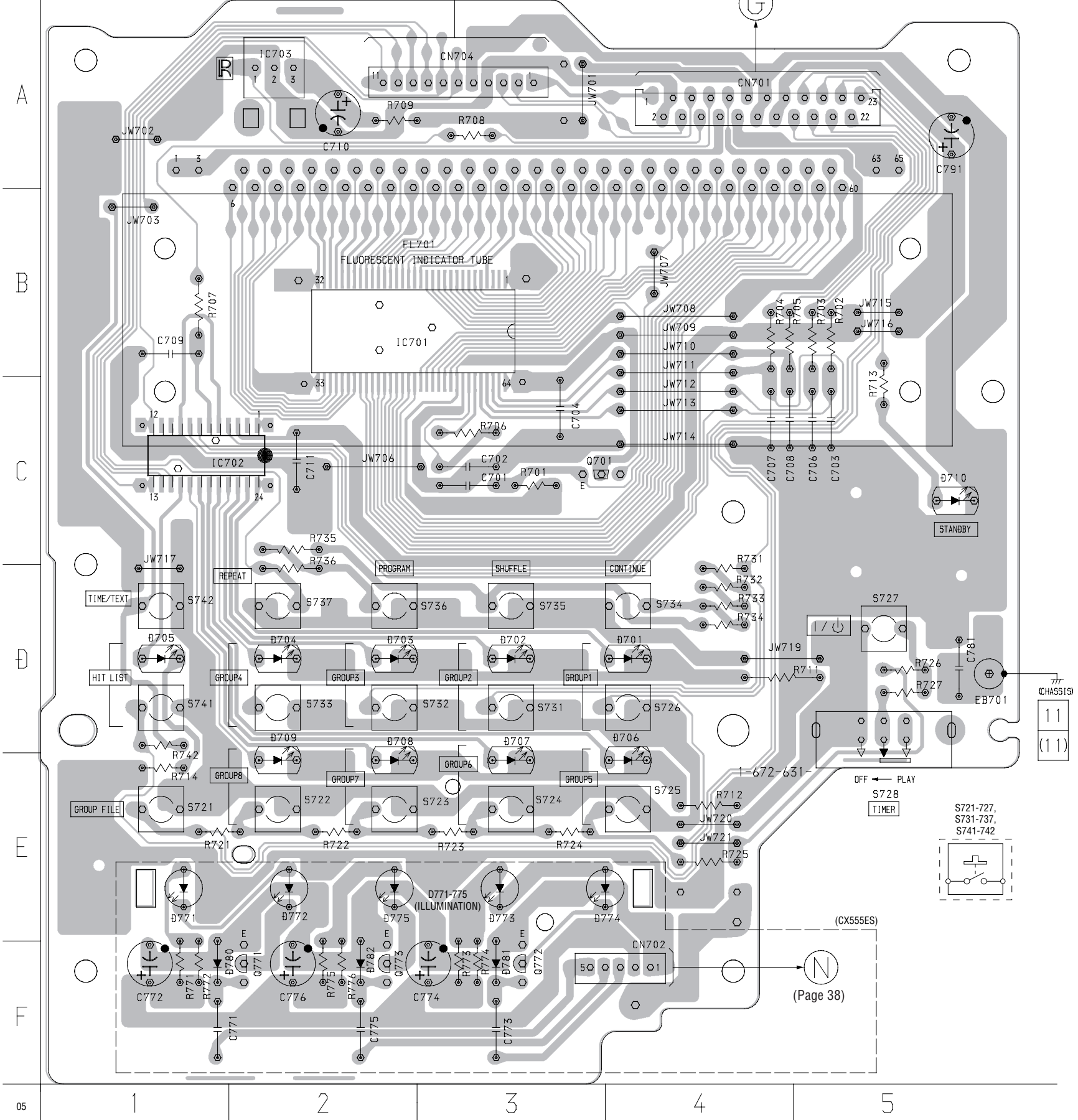



8-13. SCHEMATIC DIAGRAM - DISPLAY Board - • See page 43 for Waveforms. • See page 48 for IC Block Diagrams.

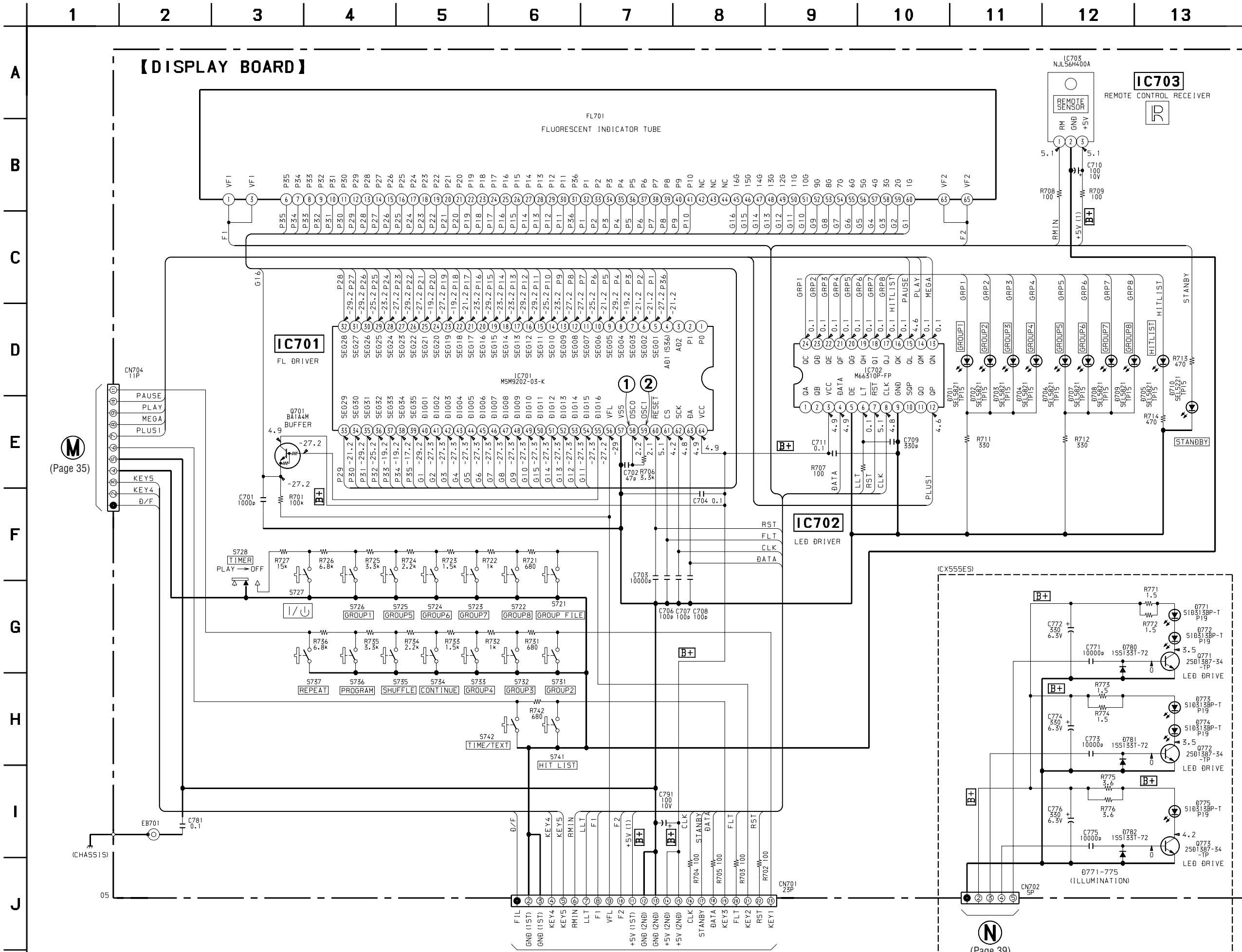

(Page 35)

(Page 28)

(Page 39)

【 JOG BOARD 】

• Semiconductor Location

Ref. No.	Location
D711	E-4
D712	E-2
D713	D-4
D714	D-4
D715	D-4
D716	D-4

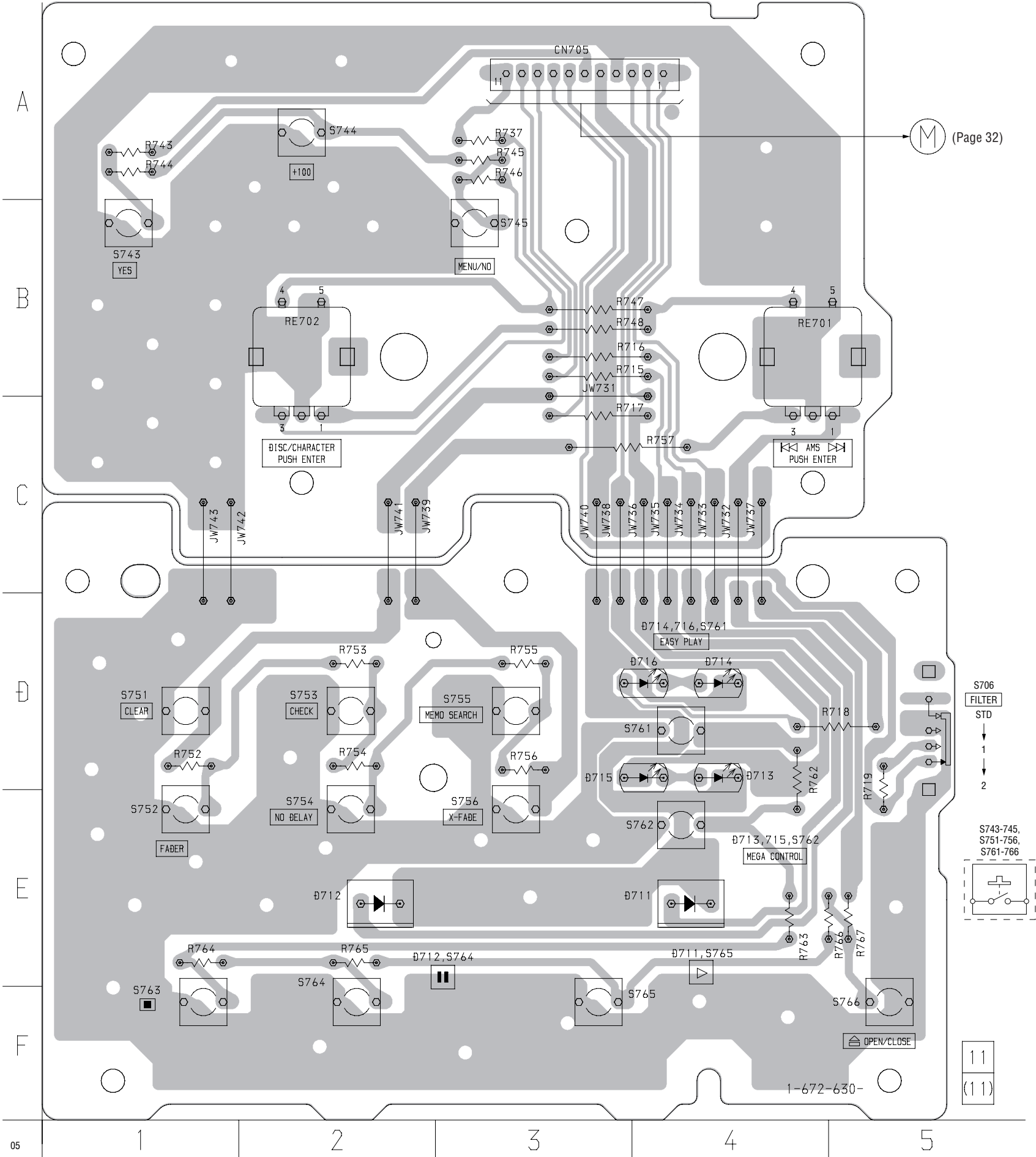

05

8-15. SCHEMATIC DIAGRAM – JOG Board –

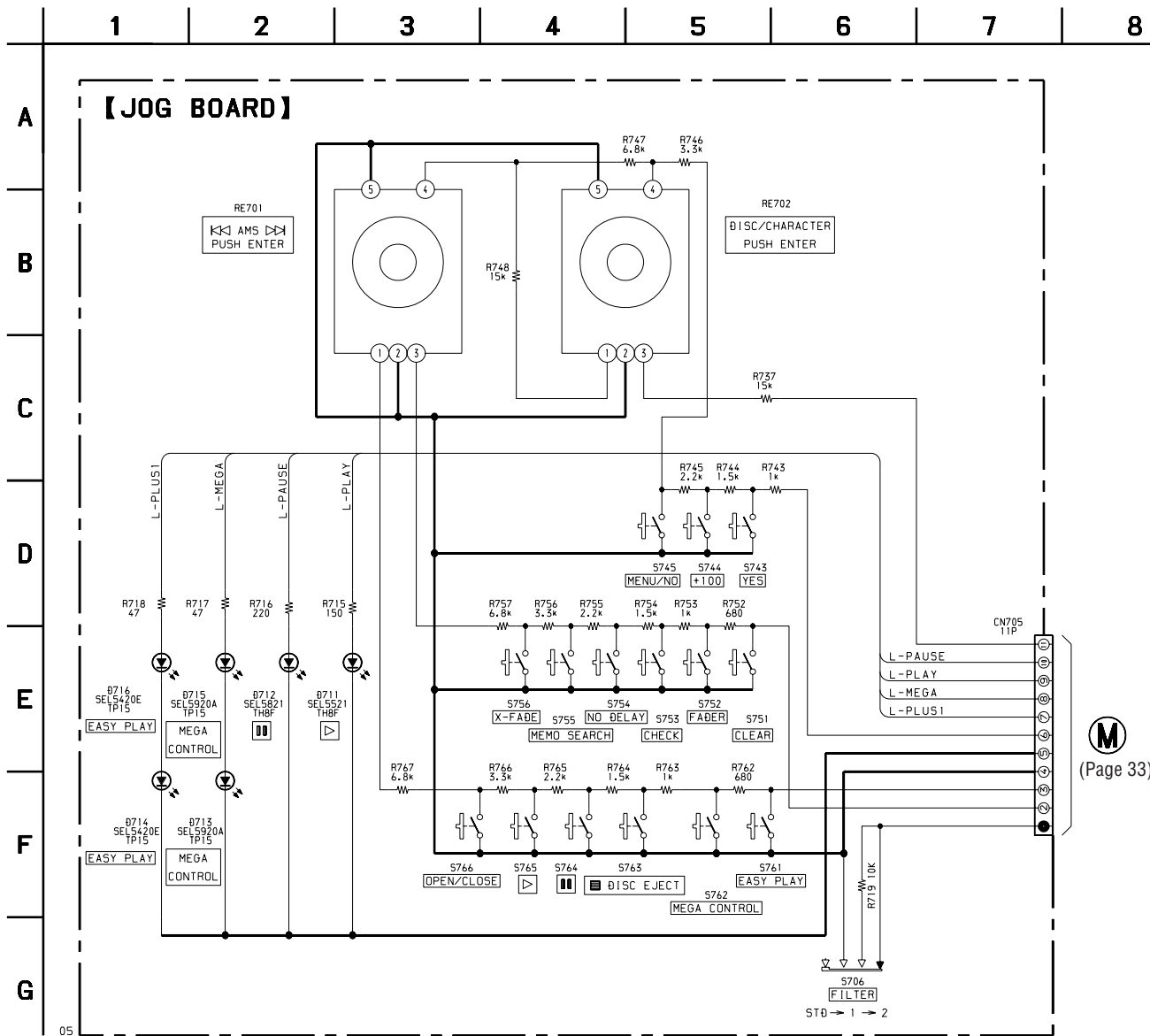

(Page 33)

8-16. PRINTED WIRING BOARDS – D.SENSOR (IN)/D.SENSOR (OUT)/SENSOR (T) Boards –  
 • See page 23 for Circuit Boards Location.

**【D.SENSOR(IN) BOARD】**

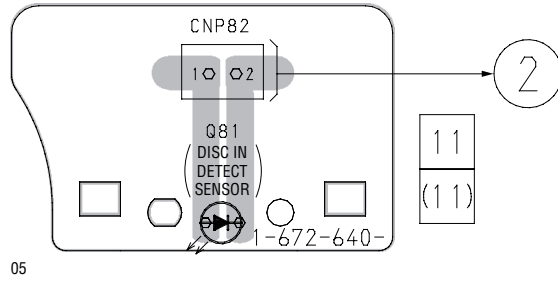

**【D.SENSOR(OUT) BOARD】**

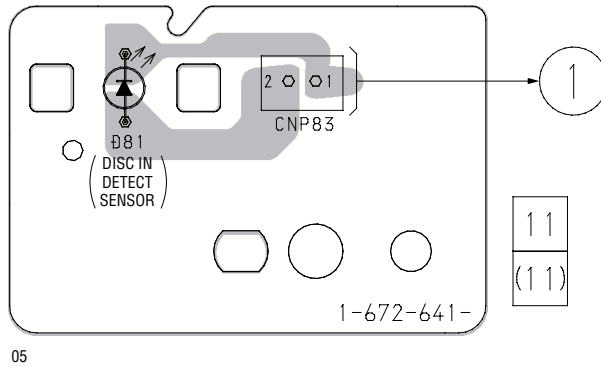

**【SENSOR(T) BOARD】**

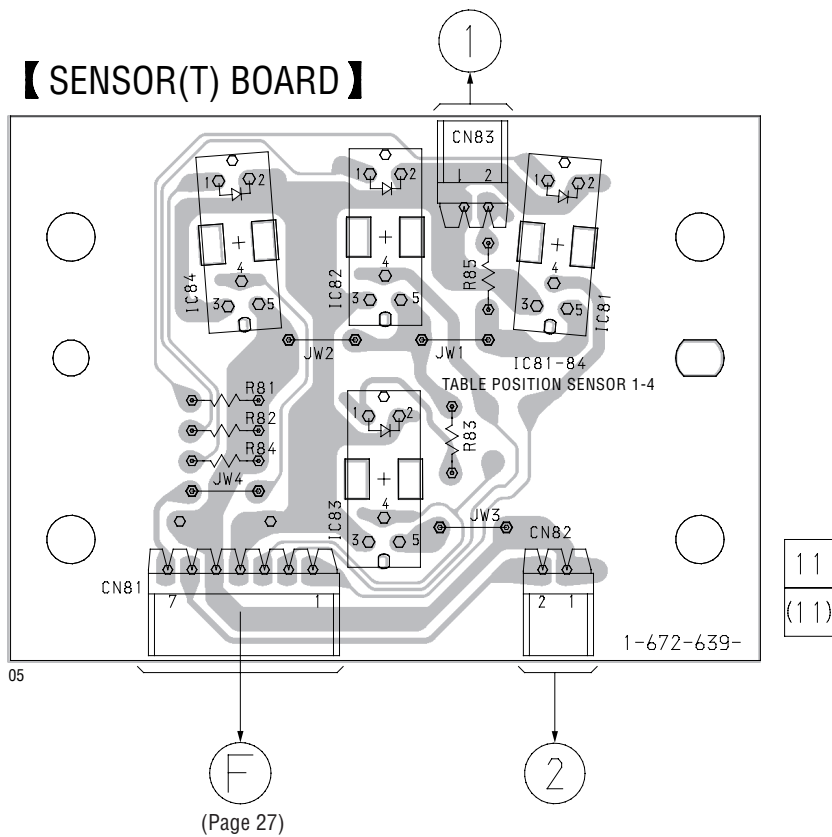

8-17. SCHEMATIC DIAGRAM – D.SENSOR (IN)/D.SENSOR (OUT)/SENSOR (T) Boards –

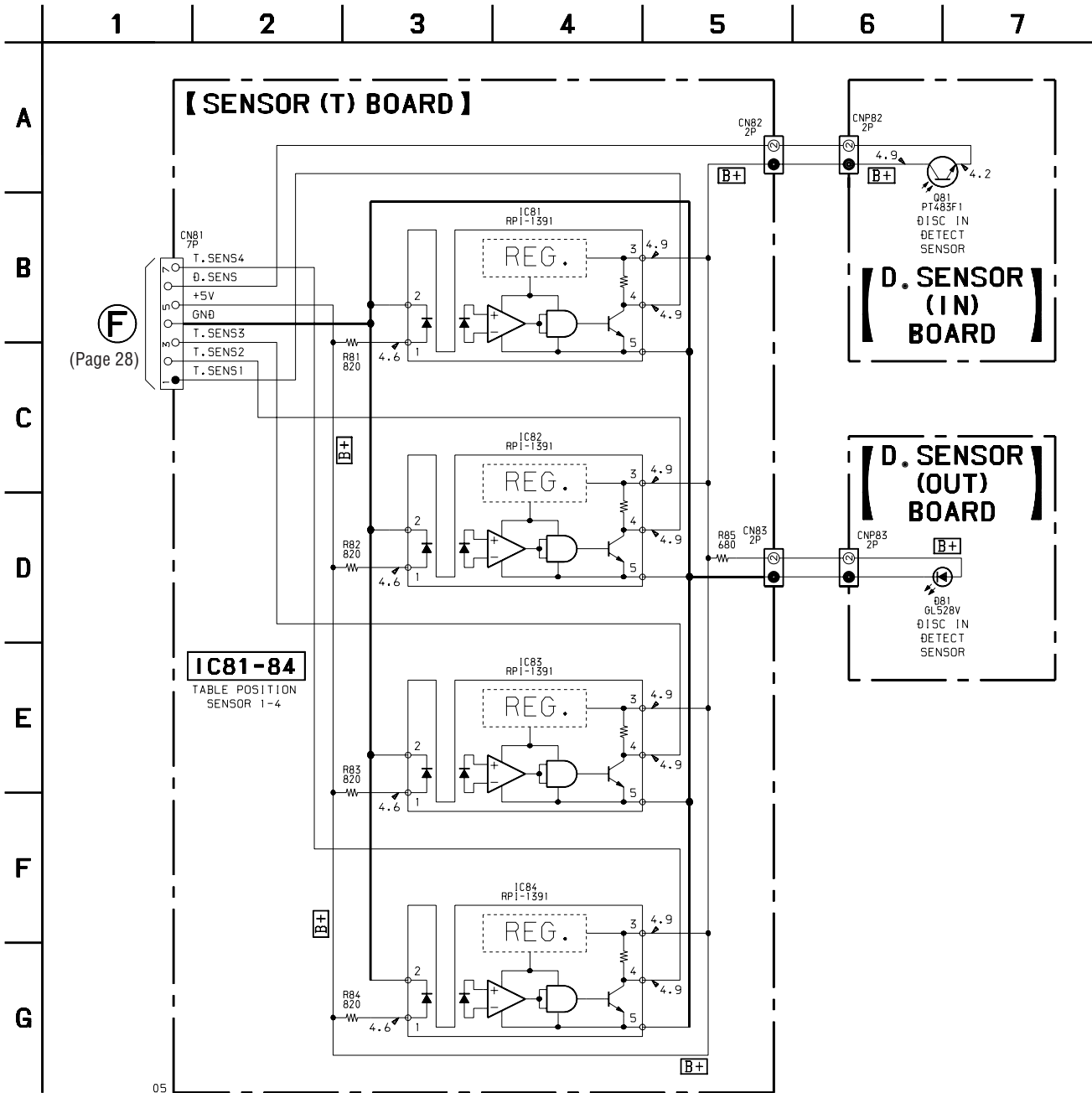

(Page 28)

8-18. PRINTED WIRING BOARDS

- D.MOTOR/D.SWITCH/KEY/LED/L.T.MOTOR/L.SWITCH (A)/L.SWITCH (B) Boards -

• See page 23 for Circuit Boards Location.

【LED BOARD】

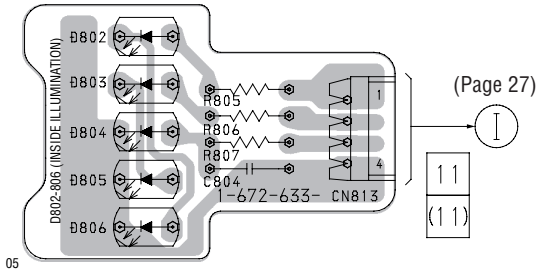

【KEY BOARD】

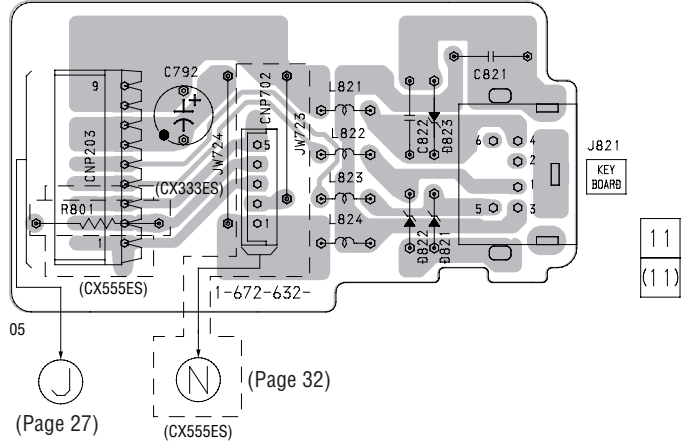

【D.SWITCH BOARD】

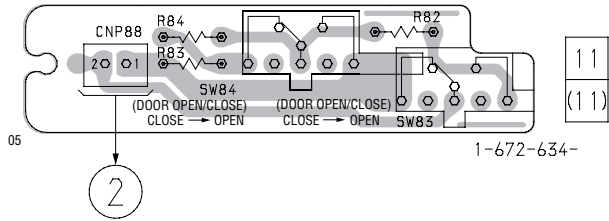

【L.T.MOTOR BOARD】

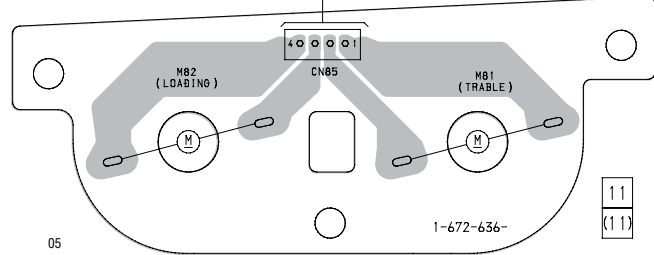

【D.MOTOR BOARD】

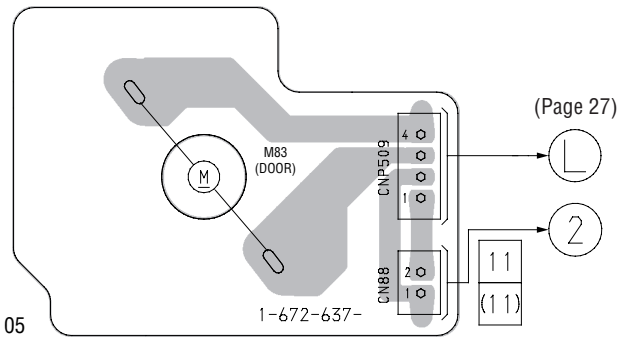

【L.SWITCH(A) BOARD】

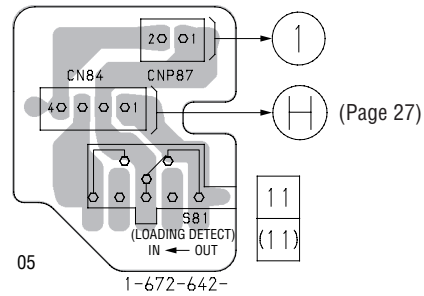

【L.SWITCH(B) BOARD】

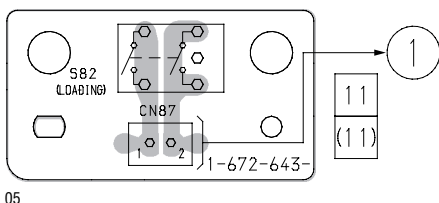

8-19. SCHEMATIC DIAGRAM  
 - D.MOTOR/D.SWITCH/KEY/LED/L.T.MOTOR/L.SWITCH (A)/L.SWITCH (B) Boards -

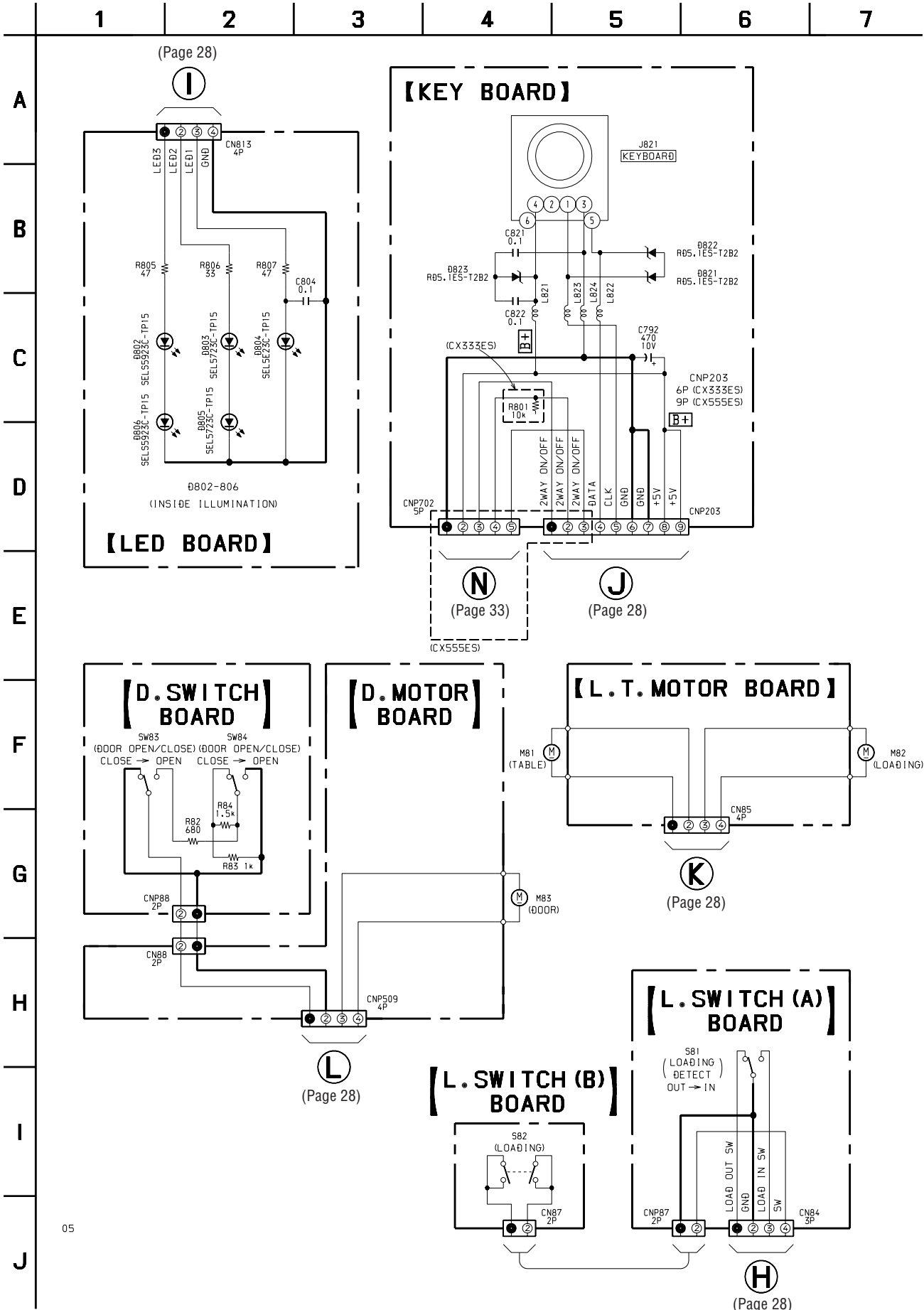

05

8-20. PRINTED WIRING BOARD – POWER Board – • See page 23 for Circuit Boards Location.

【POWER BOARD】

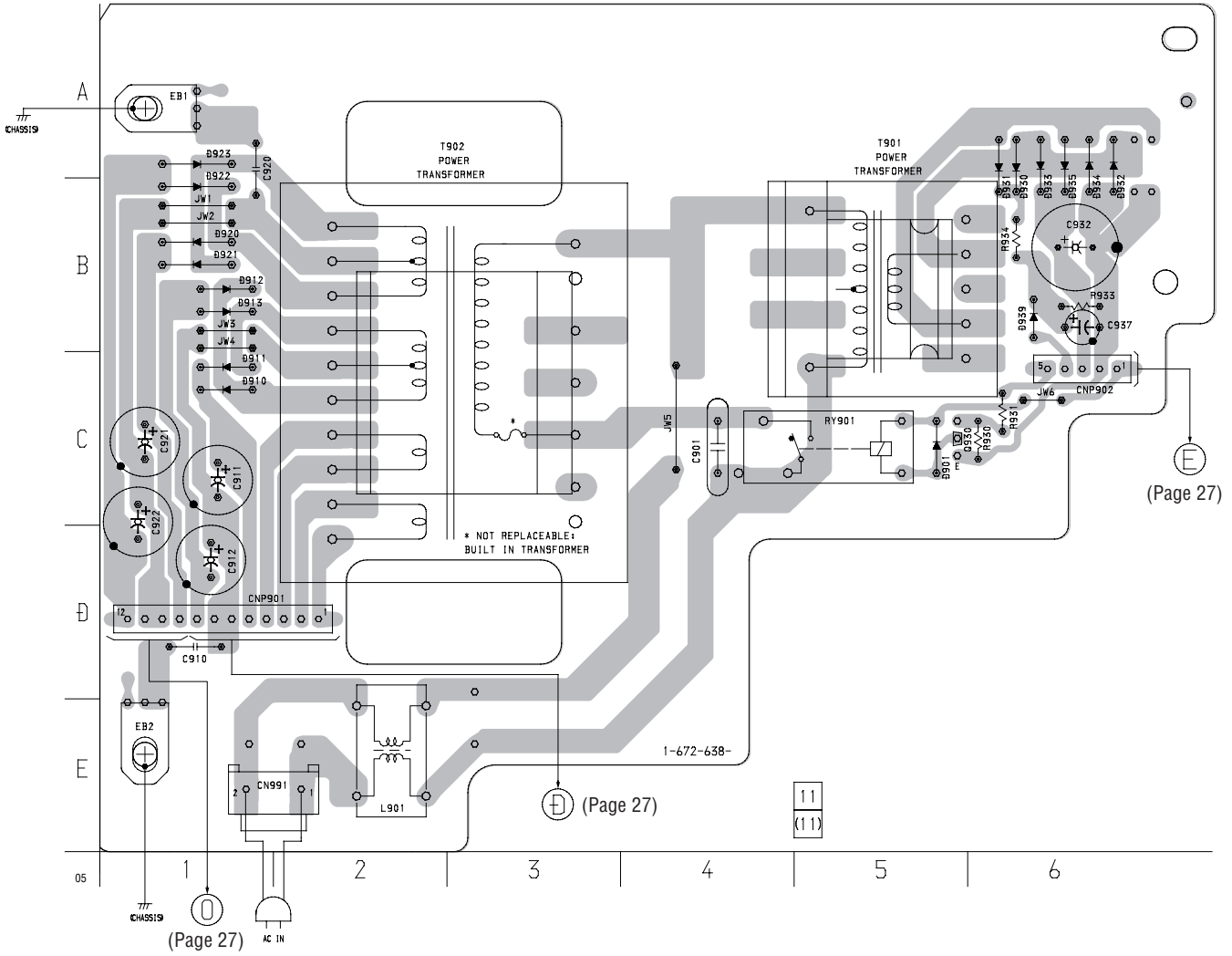

• Semiconductor Location

Ref. No.	Location	Ref. No.	Location
D901	C-5	D930	B-6
D910	C-1	D931	B-6
D911	C-1	D932	B-6
D912	B-1	D933	B-6
D913	B-1	D934	B-6
D920	B-1	D935	B-6
D921	B-1	D939	B-6
D922	B-1	Q930	C-5
D923	A-1		



8-21. SCHEMATIC DIAGRAM – POWER Board –

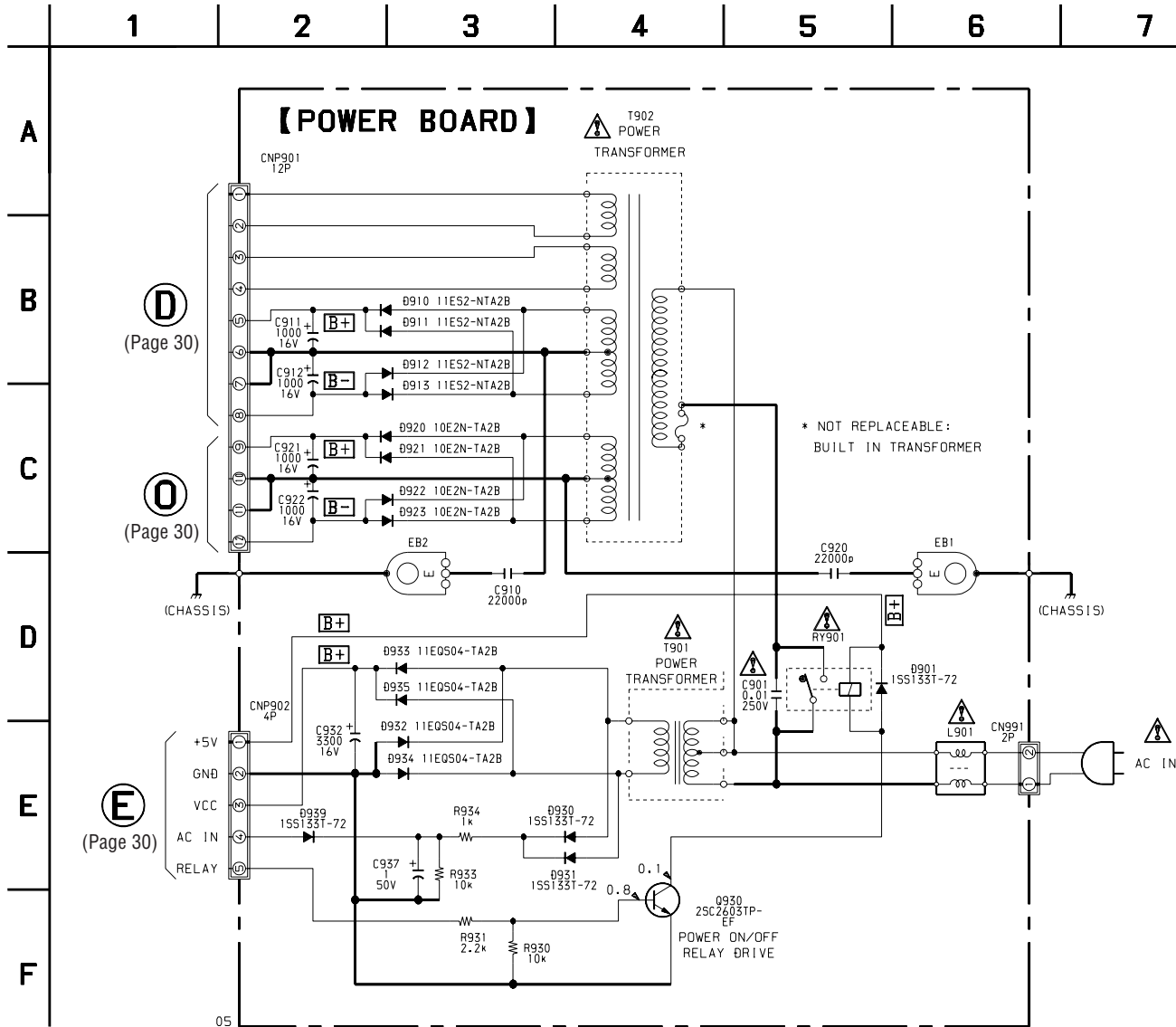

<p>The components identified by mark ⚠ or dotted line with mark ⚠ are critical for safety. Replace only with part number specified.</p>	<p>Les composants identifiés par une marque ⚠ sont critiques pour la sécurité. Ne les remplacer que par une pièce portant le numéro spécifié.</p>
---	---

• Waveforms  
– BD Board –

1 IC101 26 (MDP)

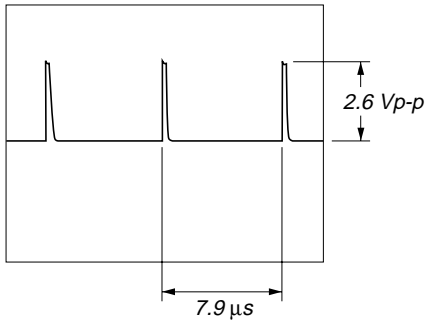

6 IC101 61 (LRCK)

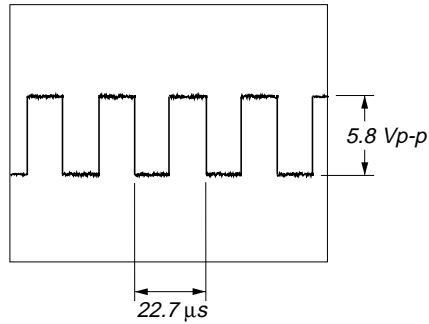

2 IC101 39 (FE)

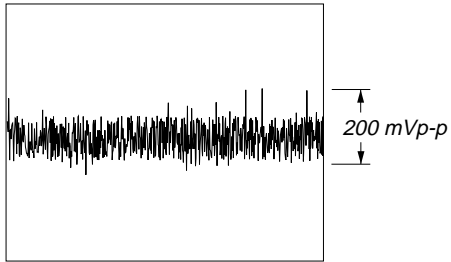

7 IC101 62 (BCK)

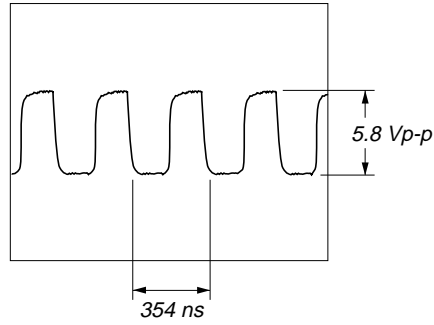

3 IC101 41 (TE)

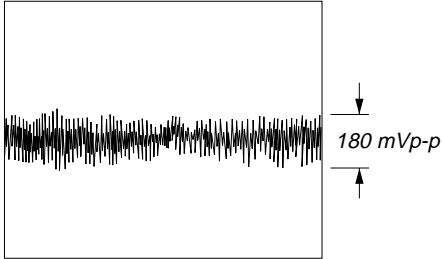

8 IC101 66 (XTAL)

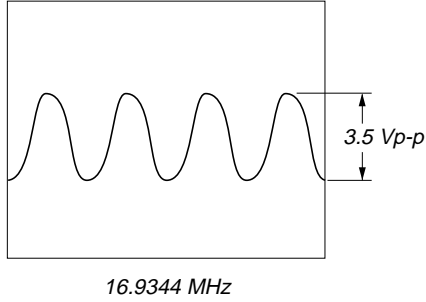

4 IC101 43 (RFDC), IC103 16 (RFO)

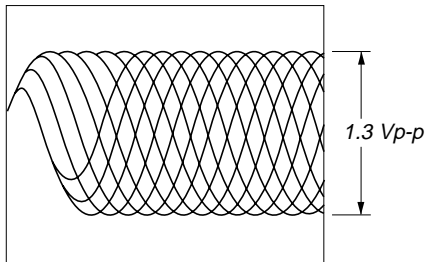

5 IC101 51 (RFAC)

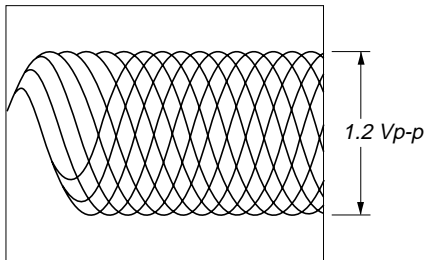

– MAIN Board –

1 IC201 1 (INVO)

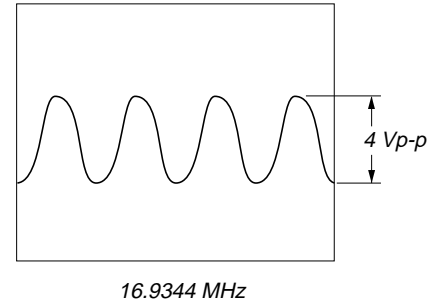

2 IC201 2 (BCKI)

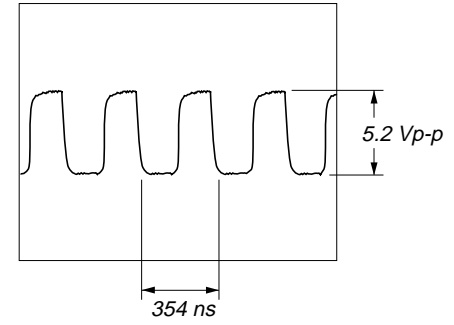

3 IC201 3 (LRCKI)

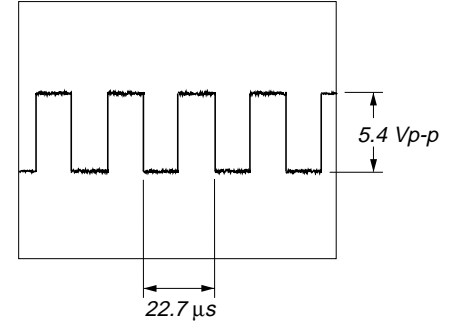

4 IC201 28 (XOUT)

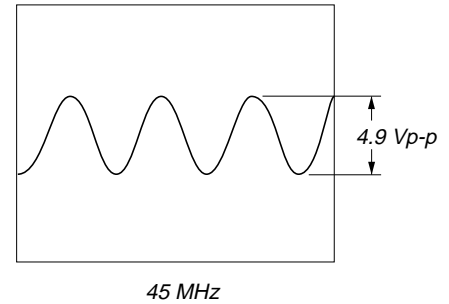

5 IC201 40, 48 (64FSO, 64FSI)

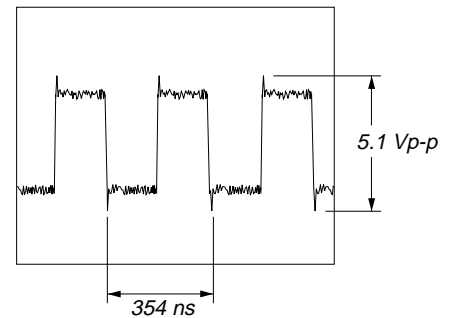

- DISPLAY Board -

6 IC201 ④③, ④⑦ (256FSO, MCLKI)

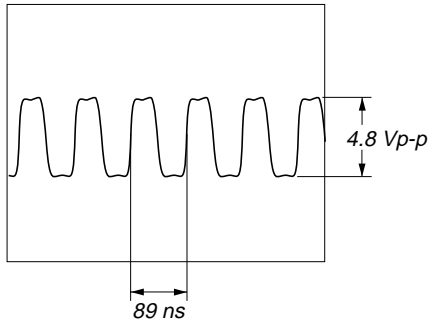

1 IC701 ③⑧ (OSCO)

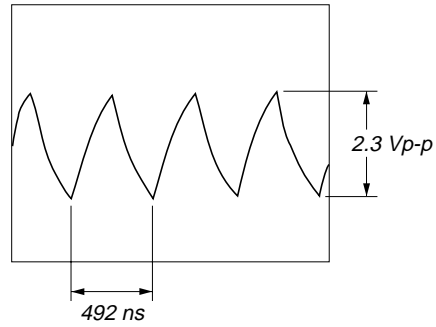

7 IC201 ⑤④ (128FSO)

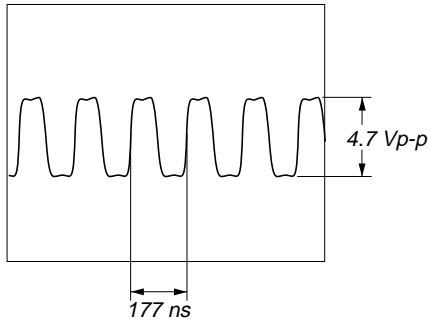

2 IC701 ⑤⑨ (OSCI)

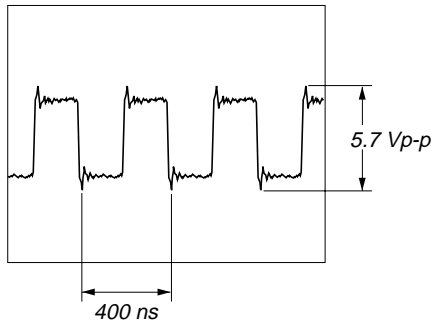

8 IC201 ⑤⑥ (INVI)

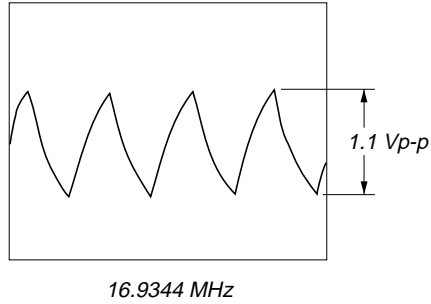

9 IC501 ①② (X'TAL OSC2)

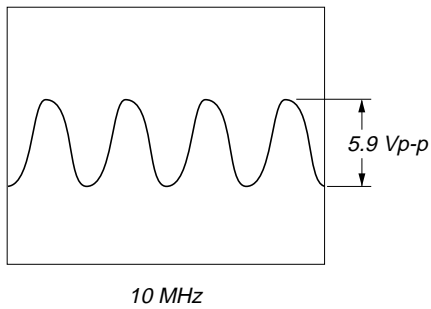

10 IC501 ①⑤ (X IN)

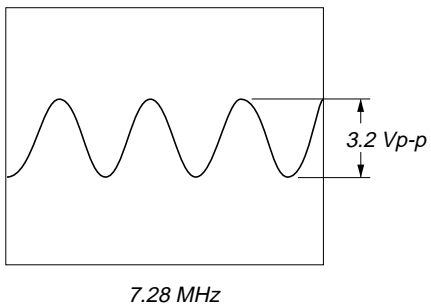

• IC Block Diagrams  
 – BD Board –

IC101 CXD2587Q

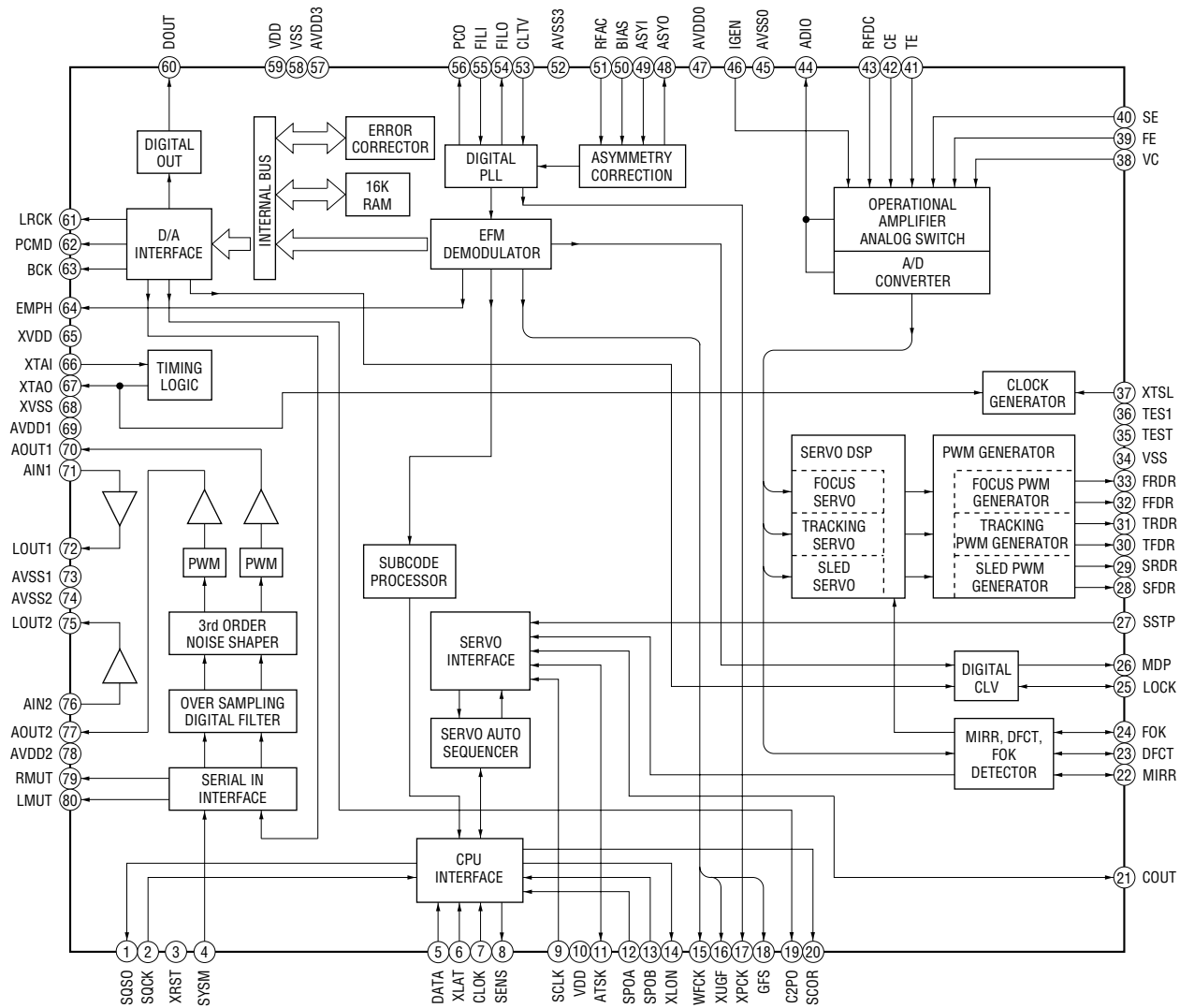

IC103 CXA2568M-T6

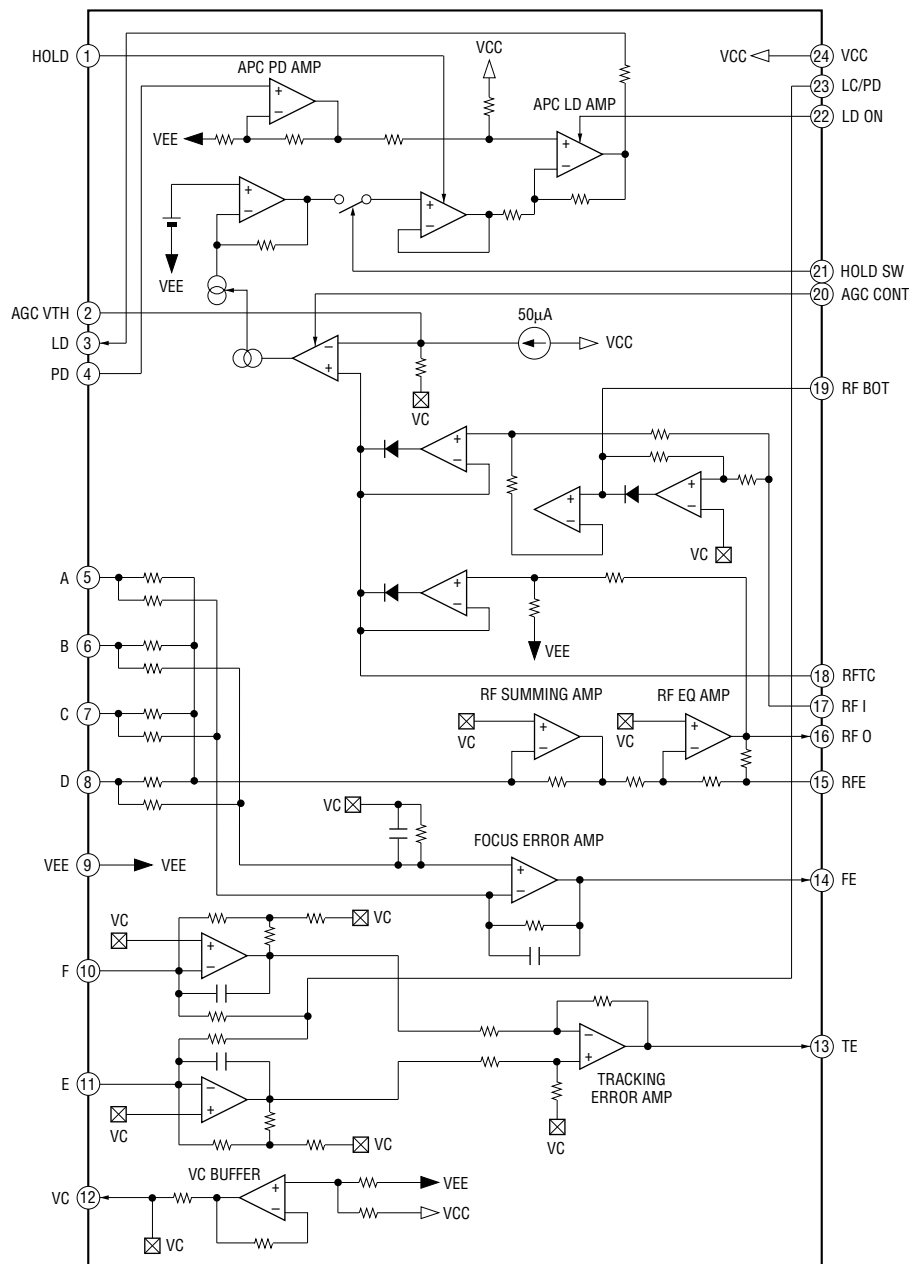

– MAIN Board –

IC201 CXD8735N-TP

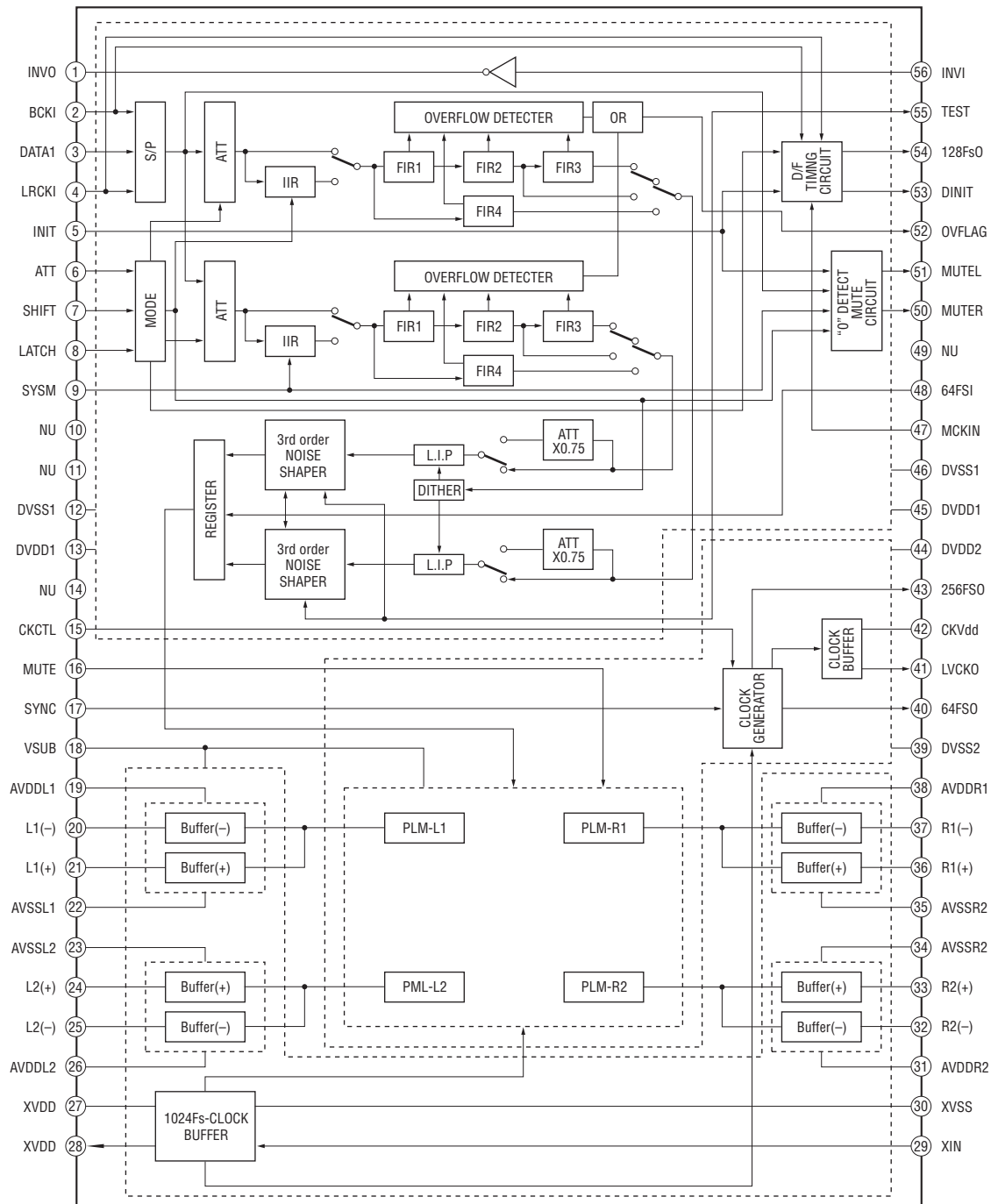

**IC202 CXA8055M**

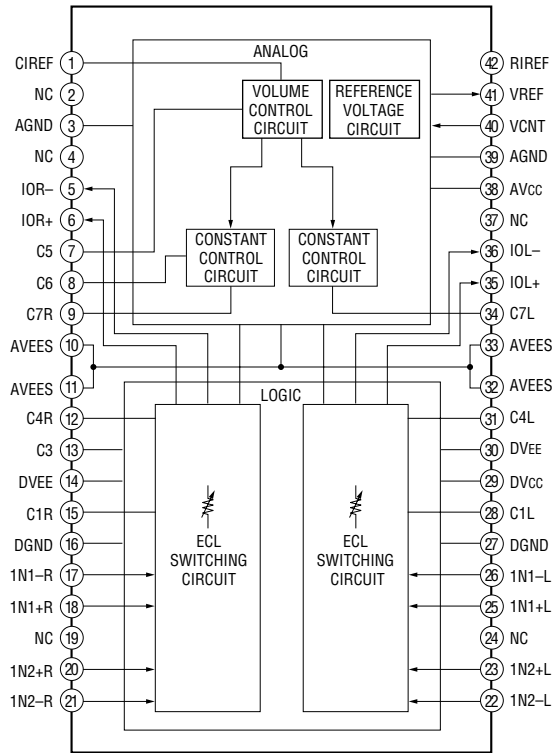

**IC505, 560 LA6510**

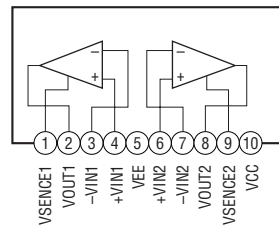

**IC931 LA5601**

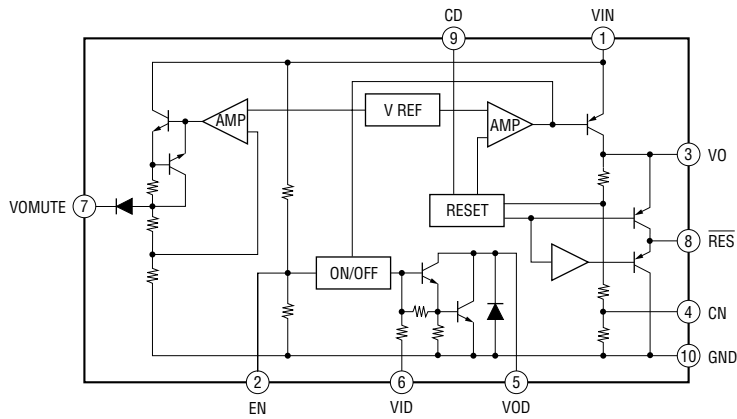

– DISPLAY Board –  
 IC702 M66310FP

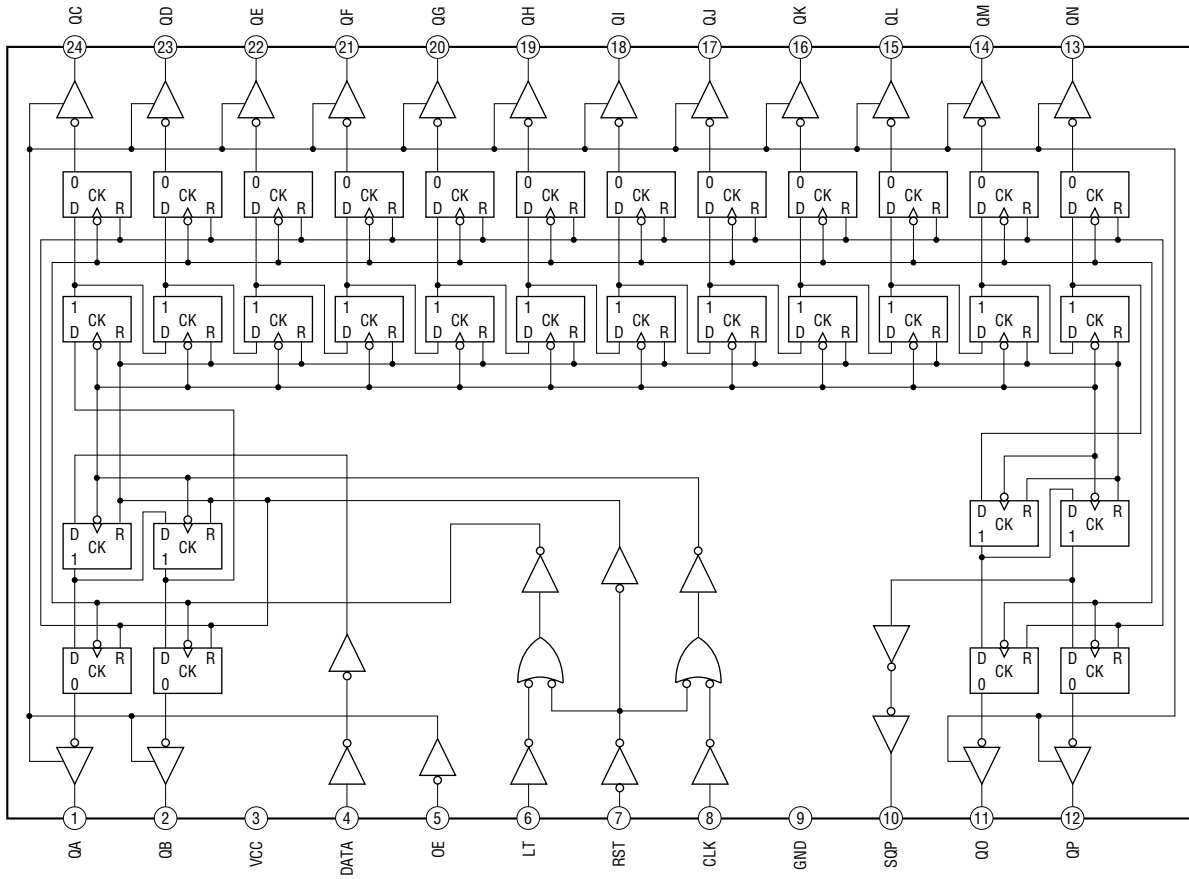



## 8-22. IC PIN FUNCTION DESCRIPTION

- BD BOARD IC101 CXD2587Q (DIGITAL SIGNAL PROCESSOR, DIGITAL SERVO PROCESSOR, DIGITAL FILTER, D/A CONVERTER)

Pin No.	Pin Name	I/O	Description
1	SQSO	O	Subcode Q data output to the system controller (IC501)
2	SQCK	I	Subcode Q data reading clock signal input from the system controller (IC501)
3	XRST	I	System reset signal input from the system controller (IC501) “L”: reset
4	SYSM	I	Analog line muting on/off control signal input from the system controller (IC501) “H”: line muting on
5	DATA	I	Command serial data input from the system controller (IC501)
6	XLAT	I	Command latch pulse input from the system controller (IC501)
7	CLOK	I	Command serial data transfer clock signal input from the system controller (IC501)
8	SENS	O	Internal status monitor output to the system controller (IC501)
9	SCLK	I	SENSE serial data reading clock input from the system controller (IC501)
10	VDD	—	Power supply terminal (+5V) (digital system)
11	ATSK	I/O	Input pin for anti-shock (fixed at “L”)
12	SPOA	I	Microcomputer escape interface input A terminal Not used (open)
13	SPOB	I	Microcomputer escape interface input B terminal Not used (open)
14	XLON	O	Microcomputer escape interface output to the CXA2568M (IC103)
15	WFCK	O	WFCK output terminal Not used (open)
16	XUGF	O	Not used (open)
17	XPCK	O	Not used (open)
18	GFS	O	Not used (open)
19	C2PO	O	Not used (open)
20	SCOR	O	Subcode sync (S0+S1) detection signal output to the system controller (IC501)
21	COUT	I/O	Numbers of track counted signal input/output terminal Not used (open)
22	MIRR	I/O	Mirror signal input/output terminal Not used (open)
23	DFCT	I/O	Defect signal input/output terminal Not used (open)
24	FOK	I/O	Focus OK input/output terminal Not used (open)
25	LOCK	I/O	GFS is sampled by 460 Hz “H” when GFS is “H” Not used (open)
26	MDP	O	Spindle motor (M101) servo drive signal output to the BA6392FP (IC102)
27	SSTP	I	Limit in detect switch (S101) input terminal
28	SFDR	O	Sled servo drive PWM signal (+) output to the BA6392FP (IC102)
29	SRDR	O	Sled servo drive PWM signal (-) output to the BA6392FP (IC102)
30	TFDR	O	Tracking servo drive PWM signal (+) output to the BA6392FP (IC102)
31	TRDR	O	Tracking servo drive PWM signal (-) output to the BA6392FP (IC102)
32	FFDR	O	Focus servo drive PWM signal (+) output to the BA6392FP (IC102)
33	FRDR	O	Focus servo drive PWM signal (-) output to the BA6392FP (IC102)
34	VSS	—	Ground terminal (digital system)
35	TEST	I	Input terminal for the test (fixed at “L”)
36	TES1	I	Input terminal for the test (fixed at “L”)
37	XTSL	I	Input terminal for the system clock frequency setting “L”: 45.1584 MHz, “H”: 22.5792 MHz (fixed at “L” in this set)
38	VC	I	Middle point voltage (+2.5V) input from the CXA2568M (IC103)
39	FE	I	Focus error signal input from the CXA2568M (IC103)
40	SE	I	Sled error signal input from the CXA2568M (IC103)
41	TE	I	Tracking error signal input from the CXA2568M (IC103)
42	CE	I	Command chip enable signal input from the CXA2568M (IC103)
43	RFDC	I	RF signal input from the CXA2568M (IC103)

Pin No.	Pin Name	I/O	Description
44	ADIO	O	Monitor output of the A/D converter input signal Not used (open)
45	AVSS0	—	Ground terminal (digital system)
46	IGEN	I	Stabilized current input for operational amplifiers
47	AVDD0	—	Power supply terminal (+5V) (digital system)
48	ASYO	O	Playback EFM full-swing output terminal
49	ASYI	I	Playback EFM asymmetry comparator voltage input terminal
50	BIAS	I	Playback EFM asymmetry circuit constant current input terminal
51	RFAC	I	EFM signal input from the CXA2568M (IC103)
52	AVSS3	—	Ground terminal (digital system)
53	CLTV	I	Internal VCO control voltage input of the playback master PLL
54	FILO	O	Filter output for master clock of the playback master PLL
55	FILI	I	Filter input for master clock of the playback master PLL
56	PCO	O	Phase comparison output for master clock of the playback EFM master PLL
57	AVDD3	—	Power supply terminal (+5V) (digital system)
58	VSS	—	Ground terminal (digital system)
59	VDD	—	Power supply terminal (+5V) (digital system)
60	DOUT	O	Digital audio signal output to the DIGITAL OUT OPTICAL (IC901)
61	LRCK	O	L/R sampling clock signal (44.1 kHz) output to the D/A converter (IC201)
62	PCMD	O	D/A interface serial data output to the D/A converter (IC201)
63	BCK	O	Bit clock signal (2.8224 MHz) output to the D/A converter (IC201)
64	EMPH	O	De-emphasis control signal output terminal Not used (open)
65	XVDD	—	Power supply terminal (+5V) (crystal oscillator system) Not used (open)
66	XTAI	I	System clock input terminal (16.9344 MHz)
67	XTAO	O	System clock output terminal (16.9344 MHz) Not used (open)
68	XVSS	—	Ground terminal (crystal oscillator system) Not used (open)
69	AVDD1	—	Power supply terminal (+5V) (analog system)
70	AOUT1	O	L-ch analog audio signal output terminal Not used (open)
71	AIN1	I	L-ch operational amplifiers input terminal Not used (open)
72	LOUT1	O	L-ch line output terminal Not used (open)
73	AVSS1	—	Ground terminal (analog system)
74	AVSS2	—	Ground terminal (analog system)
75	LOUT2	O	R-ch line output terminal Not used (open)
76	AIN2	I	R-ch operational amplifiers input terminal Not used (open)
77	AOUT2	O	R-ch analog audio signal output terminal Not used (open)
78	AVDD2	—	Power supply terminal (+5V) (analog system)
79	RMUT	O	R-ch line muting on/off control signal output terminal Not used (open)
80	LMUT	O	L-ch line muting on/off control signal output terminal Not used (open)

• MAIN BOARD IC501 MN101C12GSA1 (SYSTEM CONTROLLER)

Pin No.	Pin Name	I/O	Description
1	GND	—	Ground terminal
2	DOOR SW	I	Door open/close switch (SW83, SW84) input (A/D input) “H”: open
3	FILTER SW	I	FILTER switch (S706) input (A/D input) “H”: STD, “L”: 1 (2: center voltage input)
4	KEY1	I	Key input terminal (A/D input) GROUP2/3/4, CONTINUE, SHUFFLE, PROGRAM, REPEAT keys input and rotary encoder jog dial pulse input (S731 to 737 and RE702)
5	KEY2	I	Key input terminal (A/D input) GROUP FILE, GROUP8/7/6/5/1, I/C, TIMER keys input (S721 to 728)
6	KEY3	I	Key input terminal (A/D input) HIT LIST, TIME TEXT, YES, +100, MENU/NO keys input and rotary encoder jog dial pulse input (S741 to 745 and RE702)
7	KEY4	I	Key input terminal (A/D input) CLEAR, FADER, CHECK, NO DELAY, MEMO SEARCH, X-FADE keys input and rotary encoder jog dial pulse input (S751 to 756 and RE701)
8	KEY5	I	Key input terminal (A/D input) EASY PLAY, MEGA CONTROL, ■, ■■, ▷, ≡ OPEN/CLOSE keys input and rotary encoder jog dial pulse input (S761 to 766 and RE701)
9	D.SENS	I	Disc in detect sensor (D81, Q81) input (A/D input)
10	VREF	I	Reference voltage (+5V) input terminal (for A/D converter)
11	VDD	—	Power supply terminal (+5V)
12	X'TAL OSC1	O	Main system clock output terminal (10 MHz)
13	X'TAL OSC2	I	Main system clock input terminal (10 MHz)
14	VSS	—	Ground terminal
15	XI	I	Sub system clock input terminal Not used (open)
16	XO	O	Sub system clock output terminal Not used (open)
17	GND	—	Ground terminal
18	AC IN	I	Power monitor input terminal
19	ICSW (RELAY ON/OFF)	O	Relay drive signal output for the power on/off control “H”: relay on
20	LEDLT	O	Serial data latch pulse output to the LED driver (IC702)
21	FLDATA	O	Serial data output to the FL driver (IC701) and LED driver (IC702)
22	FLLT	O	Serial data latch pulse output to the FL driver (IC701)
23	FLCLK	O	Serial data transfer clock signal output to the FL driver (IC701) and LED driver (IC702)
24	RESET OUT	O	System reset signal output to the CXD2587Q (IC101) and BA6392FP (IC102) on the CD block and FL driver (IC701) “L”: reset
25	STANDBY-LED	O	LED drive signal output of the STANDBY indicator (D710) “H”: LED on (standby mode)
26	RMIN	I	Remote control signal input from remote control receiver (IC703)
27	T2	I	Table position sensor (IC82) input terminal
28	T4	I	Table position sensor (IC84) input terminal
29	BUSIN	I	Sircs remote control signal input for the CONTROL A1II (J901, 902)
30	SCOR	I	Subcode sync (S0+S1) detection signal input from the CXD2587Q (IC101)
31	KBCIN	I	Serial data transfer clock signal input from the KEYBOARD (J821)
32	T1	I	Table position sensor (IC81) input terminal
33	RESET	I	System reset signal input from the reset signal generator (IC931) “L”: reset For several hundreds msec. after the power supply rises, “L” is input, then it change to “H”
34	KBCOUT	O	Serial data transfer clock signal output to the KEYBOARD (J821)
35	KBDOUT	O	Serial data output to the KEYBOARD (J821)
36	KBDIN	I	Serial data input from the KEYBOARD (J821)
37	TEST-PULSE2	O	Disc in detect sensor test output terminal
38	TEST PULSE	O	Disc in detect sensor test output terminal

Pin No.	Pin Name	I/O	Description
39	AGC	O	Laser power control signal output to the CXA2568M (IC103) on the CD block
40	SMUTE	O	Muting on/off control signal output terminal "H" active
41	AMUTE	O	Analog line muting on/off control signal output to the CXD2587Q (IC101) "H": line muting on
42	DATA	O	Command serial data output to the CXD2587Q (IC101)
43	XLT	O	Command latch pulse output to the CXD2587Q (IC101)
44	CLK	O	Command serial data transfer clock signal output to the CXD2587Q (IC101)
45	SENS	I	Internal status monitor input from the CXD2587Q (IC101)
46	SUBQ	I	Subcode Q data input from the CXD2587Q (IC101)
47	SQCK	O	SENSE serial data reading clock and subcode Q data reading clock signal output to the CXD2587Q (IC101)
48	LED3	O	LED drive signal output of the inside illumination indicator (D802, 806) "L": LED on
49	LED2	O	LED drive signal output of the inside illumination indicator (D803, 805) "L": LED on
50	LED1	O	LED drive signal output of the inside illumination indicator (D804) "L": LED on
51	SELECT	I	Setting terminal for the model (fixed at "L")
52	T3	I	Table position sensor (IC83) input terminal
53	SELECT	I	Setting terminal for the model "H": J model, "L": other models
54	SELECT	I	Setting terminal for the model "H": ES model, "L": HiFi model (fixed at "H")
55	SELECT	I	Setting terminal for the model "H": 2 way model, "L": 1 way model
56	2WAY-LT	O	Microcomputer chip enable output to the keyboard control (IC502)
57	CX5/CX6	O	Serial data latch pulse signal output to the D/A converter (IC201)
58	CX3/CX4	O	Not used (open)
59	2WAYLT	O	Reset signal output terminal
60	AFADJ	I	Setting terminal for the test mode "L": AFADJ mode, Normally: fixed at "H"
61	ADJ	I	Setting terminal for the test mode "L": ADJ mode, Normally: fixed at "H"
62	<u>WE</u>	O	Data write enable signal output to the static RAM (IC504) "L" active
63 to 77	A13, A8, A9 to A11, A14, A12, A7 to A0	O	Address signal output to the static RAM (IC504)
78	CS	O	Chip enable signal output to the static RAM (IC504) "H" active
79 to 86	D2, D1, D0, D3 to D7	I/O	Two-way data bus with the static RAM (IC504)
87	BUSOUT	O	Sires remote control signal output for the CONTROL A1II (J901, 902)
88	CD2	I	COMMAND MODE CD switch (S902) input terminal (A/D input) *1
89	CD3	I	COMMAND MODE CD switch (S902) input terminal (A/D input) *1
90	SW	I	Loading switch (S82) input (A/D input)
91	INSW	I	Loading (in) detect switch (S81) input (A/D input)
92	OUTSW	I	Loading (out) detect switch (S81) input (A/D input)
93	DOOROUT	O	Door motor drive signal (door open) output to the LA6510 (IC506)
94	DOORIN	O	Door motor drive signal (door close) output to the LA6510 (IC506)
95	GND	—	Ground terminal
96	LDOUT	O	Loading motor drive signal (load-out direction) output to the LA6510 (IC506)
97	LDIN	O	Loading motor drive signal (load-in direction) output to the LA6510 (IC506)

\*1 COMMAND MODE CD switch (S902) position

Terminal	Mode		
	1	2	3
CD2 (pin ⑧)	"H"	"L"	"H"
CD3 (pin ⑨)	"H"	"H"	"L"

Pin No.	Pin Name	I/O	Description
98	TBLR	O	Table motor drive signal (clockwise) output to the LA6510 (IC505)
99	TBLL	O	Table motor drive signal (counterclockwise) output to the LA6510 (IC505)
100	DVDD	—	Power supply terminal (+5V) (digital system)

## SECTION 9 EXPLODED VIEWS

**NOTE:**

- -XX and -X mean standardized parts, so they may have some difference from the original one.
- Color Indication of Appearance Parts  
Example:  
KNOB, BALANCE (WHITE) . . . (RED)  
                                  ↑                                  ↑  
                                  Parts Color Cabinet's Color

- Items marked “\*” are not stocked since they are seldom required for routine service. Some delay should be anticipated when ordering these items.
- The mechanical parts with no reference number in the exploded views are not supplied.
- Hardware (# mark) list and accessories and packing materials are given in the last of the electrical parts list.

The components identified by mark  $\triangle$  or dotted line with mark  $\triangle$  are critical for safety. Replace only with part number specified.

Les composants identifiés par une marque  $\triangle$  sont critiques pour la sécurité. Ne les remplacer que par une pièce portant le numéro spécifié.

**(1) CASE SECTION**

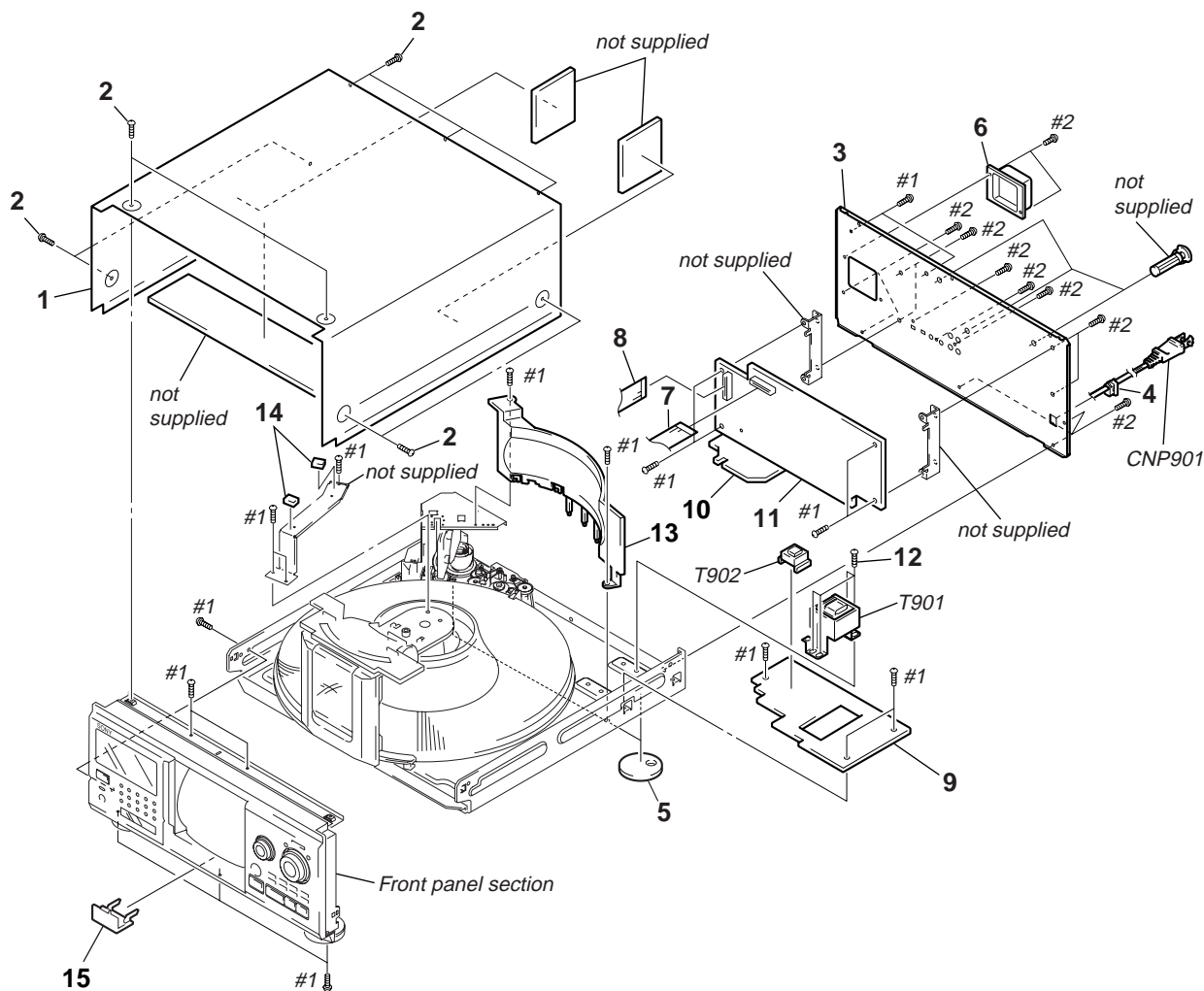

Ref. No.	Part No.	Description	Remark	Ref. No.	Part No.	Description	Remark
1	4-982-946-31	CASE		9	1-672-638-11	POWER BOARD	
2	4-210-291-01	SCREW (CASE 3 TP2)		10	1-672-629-11	JACK BOARD	
3	4-217-909-01	PANEL, BACK (CX333ES: US)		11	A-4724-649-A	MAIN BOARD, COMPLETE (CX333ES)	
3	4-217-909-11	PANEL, BACK (CX333ES: Canadian)		11	A-4724-652-A	MAIN BOARD, COMPLETE (CX555ES)	
3	4-217-909-21	PANEL, BACK (CX555ES: US)		12	3-703-249-01	SCREW, S TIGHT, +PTTWH 3X6	
3	4-217-909-31	PANEL, BACK (CX555ES: Canadian)		13	4-215-967-01	COVER (P.T.)	
* 4	3-703-244-00	BUSHING (2104), CORD		14	4-985-553-11	CUSHION	
5	4-219-325-11	CUSHION (FOOT-L)		15	4-215-960-01	COVER (CHASSIS)	
* 6	4-982-807-01	COVER (FFC)		$\triangle$ CNP901	1-783-531-31	CORD, POWER	
7	1-790-539-12	WIRE (FLAT TYPE) (23 CORE)		$\triangle$ T901	1-433-666-11	TRANSFORMER, POWER	
8	1-773-183-11	WIRE (FLAT TYPE) (23 CORE)		$\triangle$ T902	1-433-663-11	TRANSFORMER, POWER	

(2) CHASSIS SECTION

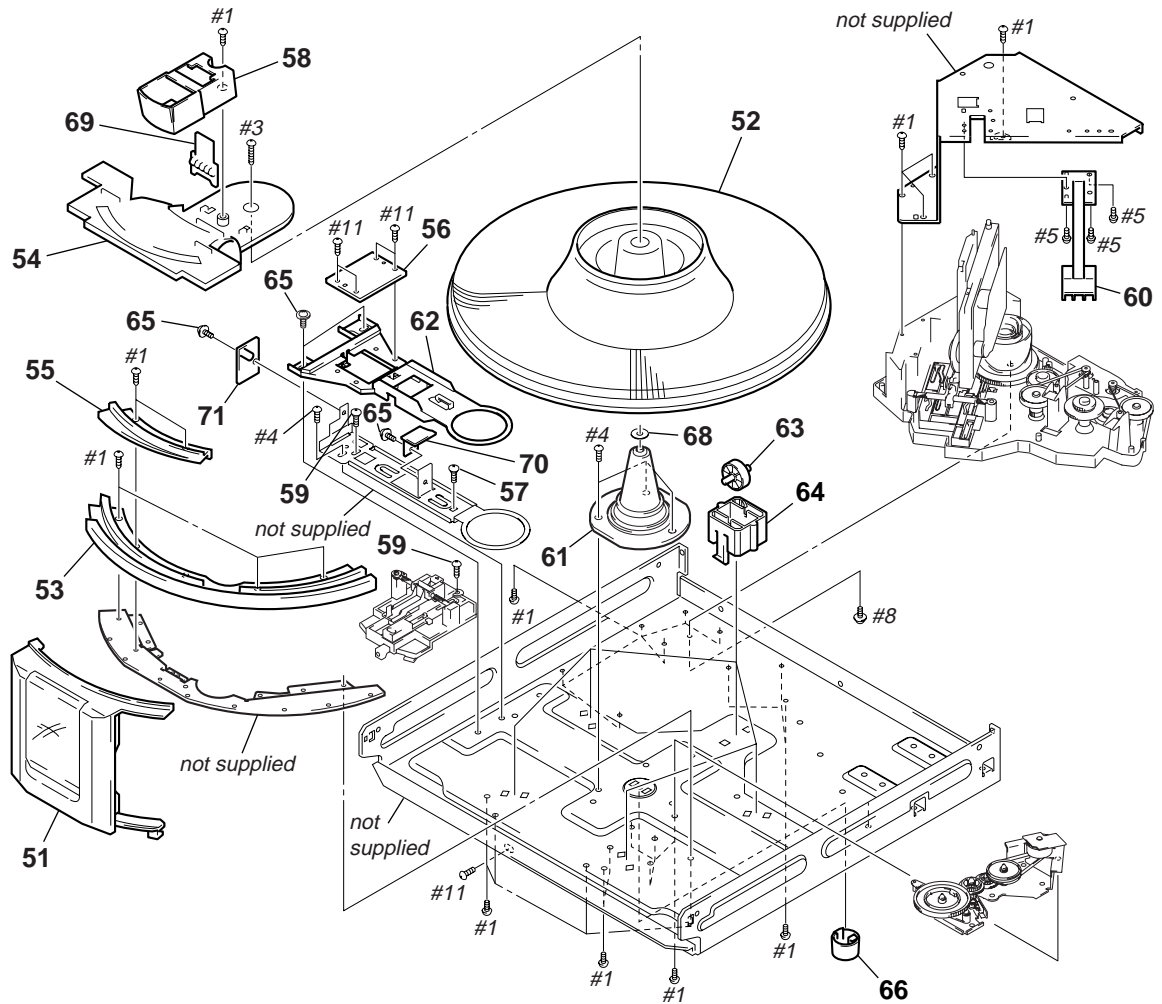

Ref. No.	Part No.	Description	Remark	Ref. No.	Part No.	Description	Remark
51	X-4951-295-1	DOOR (CD. 333ES) ASSY (CX333ES)		61	4-216-089-01	SHAFT (CENTER)	
51	X-4951-534-1	DOOR (CD. 555ES) ASSY (CX555ES)		62	4-216-091-01	HOLDER (TABLE SENSOR)	
52	X-4951-312-1	TABLE (300) ASSY		63	4-216-093-01	ROLLER	
53	4-215-952-01	GUIDE (DOOR.B)		64	4-216-092-01	HOLDER (ROLLER)	
54	4-215-953-01	GUIDE (DOOR.T)		65	3-703-249-01	SCREW, S TIGHT, +PTTWH 3X6	
55	4-215-954-01	COVER (FRONT)		66	4-931-169-01	FOOT	
56	1-672-639-11	SENSOR (T) BOARD		68	3-701-447-21	WASHER, 10	
57	4-216-096-01	SCREW (T1), STEP		69	1-672-633-11	LED BOARD	
58	4-215-968-01	WINDOW (INTERNAL ILLUMINATION)		70	1-672-640-11	D. SENSOR (IN) BOARD	
59	3-356-601-11	SCREW, STEP		71	1-672-641-11	D. SENSOR (OUT) BOARD	
60	4-216-088-02	GUIDE (DISC)					

### (3) FRONT PANEL SECTION

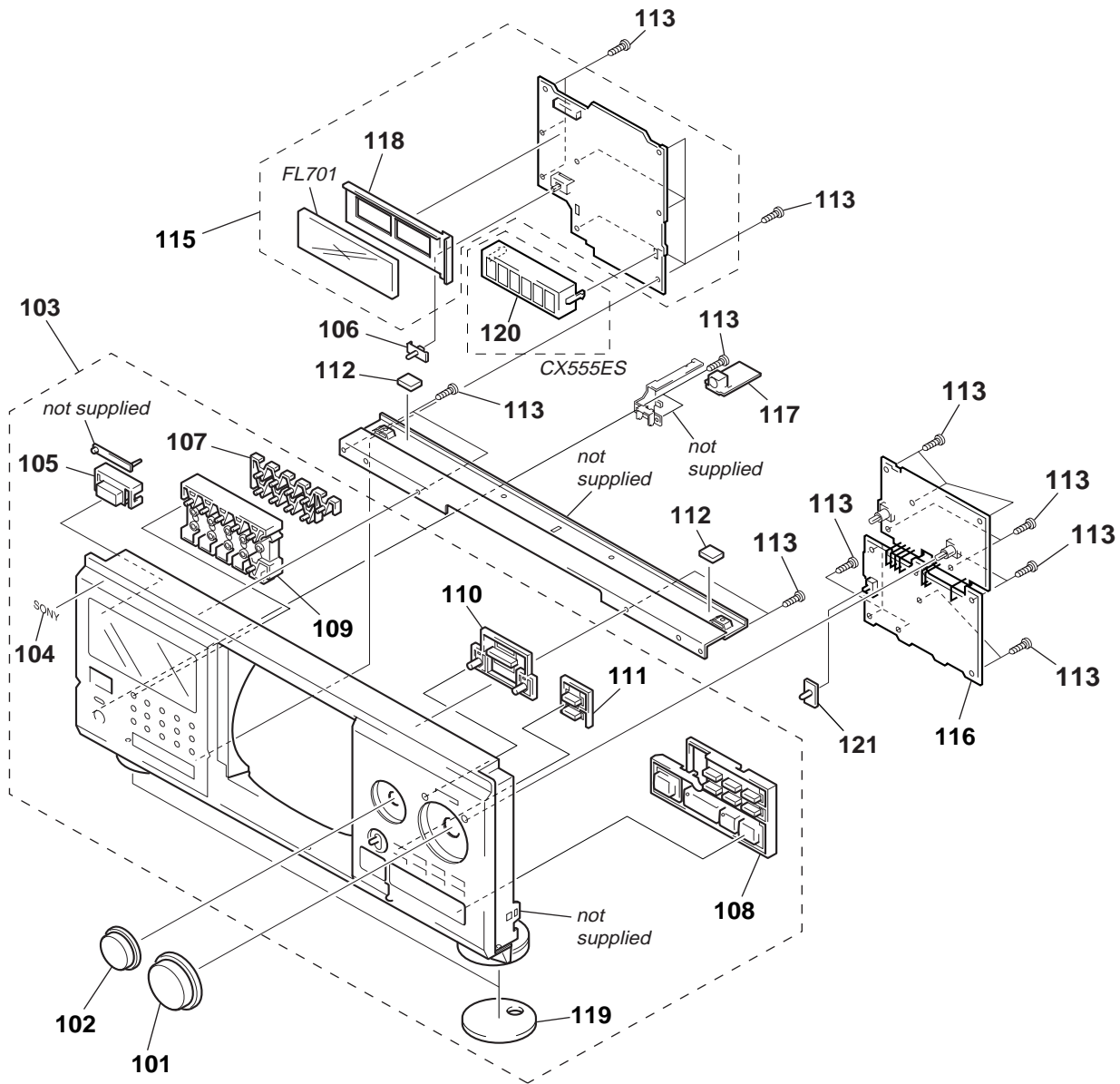

Ref. No.	Part No.	Description	Remark	Ref. No.	Part No.	Description	Remark
101	4-217-637-01	KNOB (DISC-ES)		112	4-985-553-21	CUSHION	
102	4-217-638-01	KNOB (AMS-ES)		113	4-951-620-01	SCREW (2.6X8), +BVTP	
103	X-4951-157-1	PANEL (ES) ASSY, FRONT (CX333ES)		115	A-4724-647-A	DISPLAY BOARD, COMPLETE (CX333ES)	
103	X-4951-158-1	PANEL (ES) ASSY, FRONT (CX555ES)		115	A-4724-651-A	DISPLAY BOARD, COMPLETE (CX555ES)	
104	4-963-404-21	EMBLEM (5-A), SONY		116	A-4724-646-A	JOG BOARD, COMPLETE (CX333ES)	
105	4-215-928-01	BUTTON (POWER)		116	A-4724-650-A	JOG BOARD, COMPLETE (CX555ES)	
106	3-917-216-21	KNOB (TIMER)		117	1-672-632-11	KEY BOARD	
107	4-215-816-01	BUTTON (GROUP)		118	4-982-811-11	HOLDER (FL)	
108	X-4950-856-1	BUTTON (PLAY) ASSY		119	4-219-325-01	CUSHION (FOOT-L)	
109	4-215-815-01	BUTTON (MODE)		120	4-215-969-01	HOLDER (LED.RM) (CX555ES)	
110	4-215-817-01	BUTTON (MENU)		121	4-217-639-01	KNOB (SLIDE)	
111	4-215-814-01	BUTTON (MEGA-CON)		FL701	1-517-861-11	INDICATOR TUBE, FLUORESCENT	



(4) MECHANISM DECK SECTION-1  
(CDM54-K1BD35B)

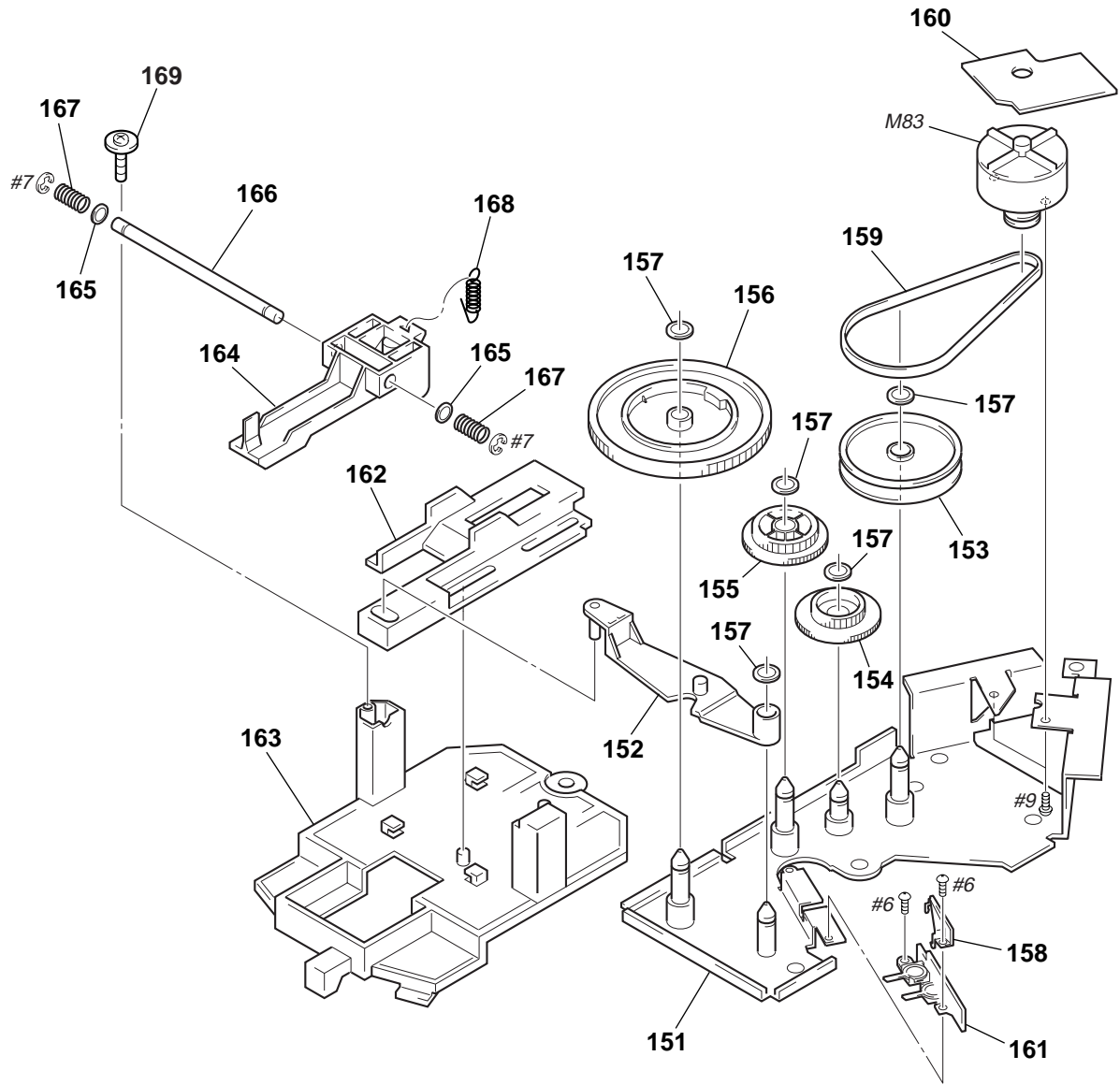

Ref. No.	Part No.	Description	Remark	Ref. No.	Part No.	Description	Remark
151	X-4950-888-1	BRACKET (DOOR.GEAR) ASSY		161	1-672-634-11	D. SWITCH BOARD	
152	4-215-959-01	LEVER (CAM.PU)		162	4-216-099-01	SLIDER (POP-UP)	
153	4-215-955-01	GEAR (DOOR.PULLEY)		163	4-216-100-01	HOLDER (POP-UP)	
154	4-215-956-01	GEAR (DOOR.CENTER)		164	4-216-098-01	LEVER (POP-UP)	
155	4-215-957-01	GEAR (DOOR.DRIVE)		165	3-701-441-21	WASHER	
156	4-215-958-01	GEAR (DOOR.CAM)		166	4-216-102-01	SHAFT (POP-UP FULCRUM)	
157	3-325-697-21	WASHER		167	4-216-103-01	SPRING (POP-UP), COMPRESSION	
158	4-219-324-01	HOLDER (L-SW)		168	4-216-104-01	SPRING (POP-UP), TENSION	
159	4-219-326-01	BELT (DIA. 42X1.2)		169	4-998-716-01	SCREW, BU FITTING	
160	1-672-637-11	D. MOTOR BOARD		M83	X-4950-062-3	DOOR MOTOR ASSY	

(5) MECHANISM DECK SECTION-2  
(CDM54-K1BD35B)

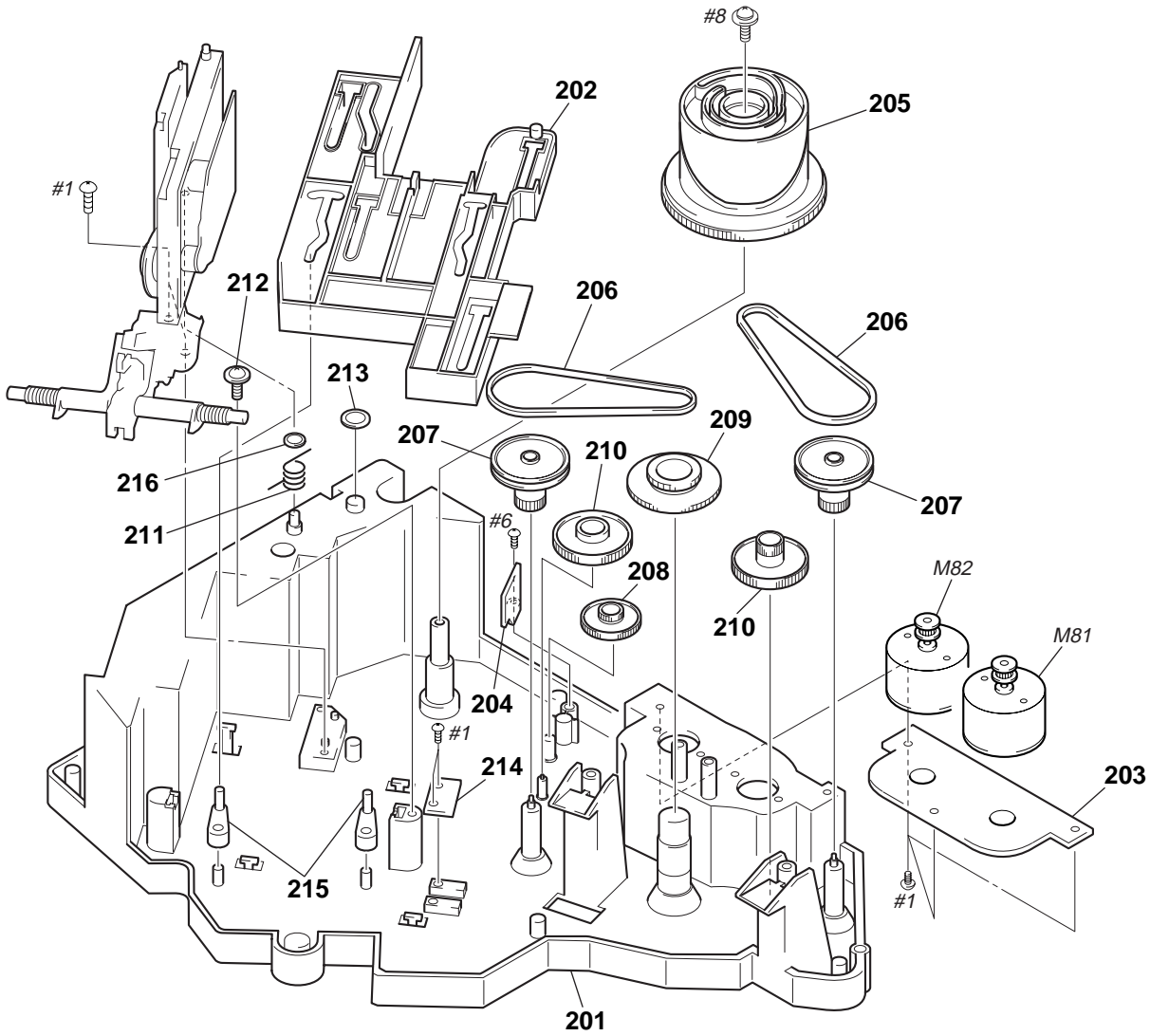

Ref. No.	Part No.	Description	Remark	Ref. No.	Part No.	Description	Remark
201	4-216-054-02	BASE (CDM)		210	4-216-058-01	GEAR (CENTER)	
202	4-216-063-01	SLIDER		211	4-216-081-01	SPRING (MG), TORSION	
203	1-672-636-11	L.T. MOTOR BOARD		212	4-998-716-01	SCREW, BU FITTING	
204	1-672-642-11	L. SWITCH (A) BOARD		213	3-701-446-21	WASHER, 8	
205	A-4672-676-A	CAM ASSY		214	1-672-643-11	L. SWITCH (B) BOARD	
206	4-216-061-01	BELT		215	4-216-062-01	LEVER (FULCRUM)	
207	4-216-060-01	PULLEY (1)		216	3-701-441-21	WASHER	
208	4-216-057-01	GEAR (CENTER 2)		M81	A-4672-675-A	MOTOR ASSY (TABLE)	
209	4-216-059-01	GEAR (TABLE)		M82	A-4672-675-A	MOTOR ASSY (LOADING)	

(6) MECHANISM DECK SECTION-3  
(CDM54-K1BD35B)

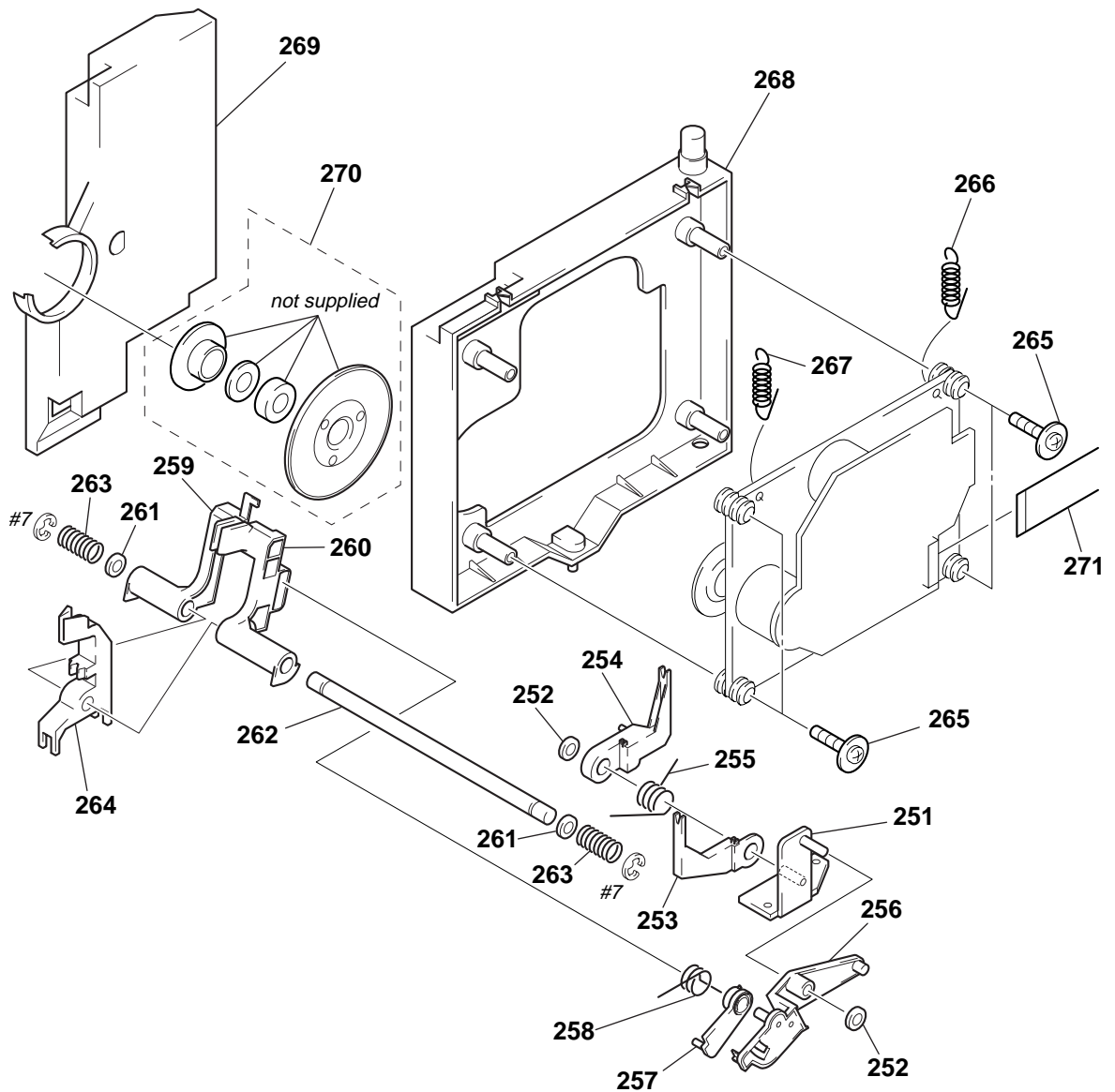

Ref. No.	Part No.	Description	Remark	Ref. No.	Part No.	Description	Remark
251	X-4950-900-1	BRACKET (LEVER) ASSY		262	4-216-066-01	SHAFT (CLAMP)	
252	3-325-697-21	WASHER		263	4-216-067-01	SPRING (CLAMP), COMPRESSION	
253	4-216-075-01	HOLDER (F)		264	4-216-070-01	LEVER (LOCK)	
254	4-216-076-01	HOLDER (R)		265	4-957-577-01	SCREW PTP WH (2.6X8) (DIA. 10)	
255	4-216-077-01	SPRING (HOLDER FR), TORSION		266	4-216-086-01	SPRING (F-2), TENSION	
256	4-216-078-01	LEVER (LOADING)		267	4-216-085-01	SPRING (F-1), TENSION	
257	4-216-079-02	LIMITTER (LEVER)		268	X-4950-901-2	HOLDER ASSY, BU	
258	4-216-080-01	SPRING (LIMITTER), TORSION		269	4-216-082-01	HOLDER (MAGNET), TORSION	
259	X-4950-885-1	HOLDER (DISC L) ASSY		270	A-4672-768-A	MAGNET ASSY	
260	X-4950-886-1	HOLDER (DISC R) ASSY		271	1-769-069-11	WIRE (FLAT TYPE) (16 CORE)	
261	3-701-441-21	WASHER					

(7) OPTICAL PICK-UP SECTION (KSM-213BFN/C2NP)

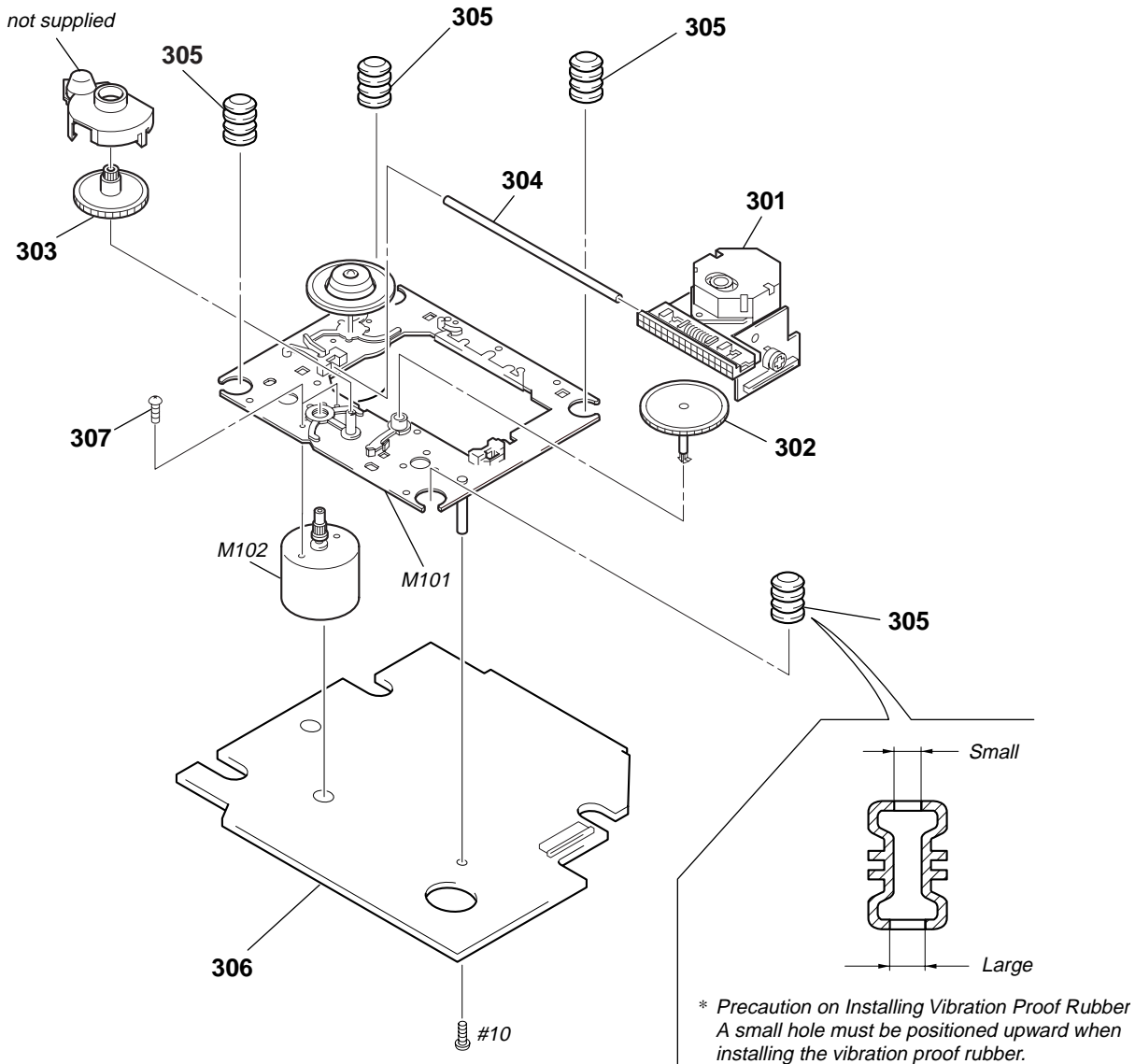

<p>The components identified by mark <math>\Delta</math> or dotted line with mark <math>\Delta</math> are critical for safety. Replace only with part number specified.</p>	<p>Les composants identifiés par marque <math>\Delta</math> sont critiques pour la sécurité. Ne les remplacer que par une pièce portant le numéro spécifié.</p>
---	---

Ref. No.	Part No.	Description	Remark	Ref. No.	Part No.	Description	Remark
$\Delta$ 301	8-820-026-03	OPTICAL PICK-UP KSM-213BFN/C2NP		306	A-4724-642-A	BD BOARD, COMPLETE	
302	2-626-907-01	GEAR (A) (S)		307	3-713-786-51	SCREW +P 2X3	
303	2-627-003-02	GEAR (B) (RP)		M101	X-2646-110-3	T. T CHASSIS ASSY (MB) (FD) (SPINDLE)	
304	2-626-908-01	SHAFT, SLED		M102	X-2625-769-1	MOTIR GEAR ASSY (MB) (RP) (SLED)	
* 305	4-992-054-01	RUBBER, VIBRATION PROOF					

# SECTION 10 ELECTRICAL PARTS LIST

BD

**NOTE:**

- Due to standardization, replacements in the parts list may be different from the parts specified in the diagrams or the components used on the set.
- -XX and -X mean standardized parts, so they may have some difference from the original one.
- RESISTORS  
All resistors are in ohms.  
METAL: Metal-film resistor.  
METAL OXIDE: Metal oxide-film resistor.  
F: nonflammable

- Items marked "\*" are not stocked since they are seldom required for routine service. Some delay should be anticipated when ordering these items.
- SEMICONDUCTORS  
In each case, u:  $\mu$ , for example:  
uA. . . :  $\mu$ A. . .      uPA. . . :  $\mu$ PA. . .  
uPB. . . :  $\mu$ PB. . .      uPC. . . :  $\mu$ PC. . .  
uPD. . . :  $\mu$ PD. . .
- CAPACITORS  
uF:  $\mu$ F
- COILS  
uH:  $\mu$ H

The components identified by mark  $\Delta$  or dotted line with mark  $\Delta$  are critical for safety. Replace only with part number specified.

Les composants identifiés par une marque  $\Delta$  sont critiques pour la sécurité. Ne les remplacer que par une pièce portant le numéro spécifié.

When indicating parts by reference number, please include the board.

Ref. No.	Part No.	Description	Remark	Ref. No.	Part No.	Description	Remark
	A-4724-642-A	BD BOARD, COMPLETE *****				< IC >	
		< CAPACITOR >					
C101	1-163-005-11	CERAMIC CHIP	470PF	10%	50V		
C102	1-163-038-00	CERAMIC CHIP	0.1uF		25V		
C103	1-163-005-11	CERAMIC CHIP	470PF	10%	50V		
C104	1-163-021-11	CERAMIC CHIP	0.01uF	10%	50V		
C106	1-164-346-11	CERAMIC CHIP	1uF		16V		
C107	1-164-346-11	CERAMIC CHIP	1uF		16V		
C108	1-163-035-00	CERAMIC CHIP	0.047uF		50V		
C109	1-163-145-00	CERAMIC CHIP	0.0015uF	5%	50V		
C110	1-163-017-00	CERAMIC CHIP	0.0047uF	5%	50V		
C111	1-163-251-11	CERAMIC CHIP	100PF	5%	50V		
C115	1-126-607-11	ELECT CHIP	47uF	20%	4V		
C116	1-126-607-11	ELECT CHIP	47uF	20%	4V		
C117	1-126-209-11	ELECT CHIP	100uF	20%	4V		
C118	1-163-275-11	CERAMIC CHIP	0.001uF	5%	50V		
C119	1-163-231-11	CERAMIC CHIP	15PF	5%	50V		
C121	1-163-038-00	CERAMIC CHIP	0.1uF		25V		
C122	1-135-155-21	TANTALUM CHIP	4.7uF	10%	16V		
C123	1-163-021-11	CERAMIC CHIP	0.01uF	10%	50V		
C124	1-164-005-11	CERAMIC CHIP	0.47uF		25V		
C125	1-163-038-00	CERAMIC CHIP	0.1uF		25V		
C126	1-163-038-00	CERAMIC CHIP	0.1uF		25V		
C127	1-109-982-11	CERAMIC CHIP	1uF	10%	10V		
C130	1-164-004-11	CERAMIC CHIP	0.1uF	10%	25V		
C131	1-135-216-11	TANTALUM CHIP	10uF	20%	10V		
C140	1-163-038-00	CERAMIC CHIP	0.1uF		25V		
C141	1-163-038-00	CERAMIC CHIP	0.1uF		25V		
C151	1-163-237-11	CERAMIC CHIP	27PF	5%	50V		
C153	1-163-038-00	CERAMIC CHIP	0.1uF		25V		
C154	1-164-336-11	CERAMIC CHIP	0.33uF		25V		
C156	1-163-237-11	CERAMIC CHIP	27PF	5%	50V		
C157	1-163-145-00	CERAMIC CHIP	0.0015uF	5%	50V		
C159	1-163-019-00	CERAMIC CHIP	0.0068uF	10%	50V		
C164	1-163-038-00	CERAMIC CHIP	0.1uF		25V		
C165	1-163-038-00	CERAMIC CHIP	0.1uF		25V		
C166	1-163-038-00	CERAMIC CHIP	0.1uF		25V		
		< CONNECTOR >					
CN101	1-770-072-11	CONNECTOR, (LIF (NON-ZIF)) FFC 23P					
CN102	1-777-937-11	CONNECTOR, FFC/FPC 16P					
						< TRANSISTOR >	
						< RESISTOR >	
IC101	8-752-386-85	IC CXD2587Q					
* IC102	8-759-455-91	IC BA6392FP-E2					
IC103	8-752-085-51	IC CXA2568M-T6					
Q101	8-729-010-08	TRANSISTOR	MSB710-RT1				
R101	1-216-077-00	METAL CHIP	15K	5%	1/10W		
R102	1-216-097-00	RES, CHIP	100K	5%	1/10W		
R103	1-216-077-00	METAL CHIP	15K	5%	1/10W		
R104	1-216-085-00	METAL CHIP	33K	5%	1/10W		
R105	1-216-097-00	RES, CHIP	100K	5%	1/10W		
R106	1-216-061-00	METAL CHIP	3.3K	5%	1/10W		
R107	1-216-061-00	METAL CHIP	3.3K	5%	1/10W		
R108	1-216-073-00	METAL CHIP	10K	5%	1/10W		
R109	1-216-121-00	RES, CHIP	1M	5%	1/10W		
R110	1-216-025-00	RES, CHIP	100	5%	1/10W		
R111	1-216-121-00	RES, CHIP	1M	5%	1/10W		
R113	1-216-121-00	RES, CHIP	1M	5%	1/10W		
R117	1-216-049-11	RES, CHIP	1K	5%	1/10W		
R123	1-216-073-00	METAL CHIP	10K	5%	1/10W		
R124	1-216-097-00	RES, CHIP	100K	5%	1/10W		
R131	1-216-037-00	METAL CHIP	330	5%	1/10W		
R135	1-216-295-00	SHORT	0				
R136	1-216-295-00	SHORT	0				
R137	1-216-295-00	SHORT	0				
R138	1-216-295-00	SHORT	0				
R143	1-216-103-00	METAL CHIP	180K	5%	1/10W		
R144	1-216-103-00	METAL CHIP	180K	5%	1/10W		
R147	1-216-081-00	METAL CHIP	22K	5%	1/10W		
R148	1-216-001-00	METAL CHIP	10	5%	1/10W		
R149	1-216-003-11	RES, CHIP	12	5%	1/10W		
R158	1-216-111-00	METAL CHIP	390K	5%	1/10W		
R159	1-216-101-00	METAL CHIP	150K	5%	1/10W		
R161	1-216-308-00	METAL CHIP	4.7	5%	1/10W		
R162	1-216-101-00	METAL CHIP	150K	5%	1/10W		
R615	1-216-049-11	RES, CHIP	1K	5%	1/10W		
R616	1-216-049-11	RES, CHIP	1K	5%	1/10W		
R617	1-216-049-11	RES, CHIP	1K	5%	1/10W		
R618	1-216-049-11	RES, CHIP	1K	5%	1/10W		

<b>BD</b>	<b>DISPLAY</b>
-----------	----------------

Ref. No.	Part No.	Description	Remark
		< SWITCH >	
S101	1-572-085-11	SWITCH, LEAF (LIMIT IN)	
*****			
	A-4724-647-A	DISPLAY BOARD, COMPLETE (CX333ES)	
	A-4724-651-A	DISPLAY BOARD, COMPLETE (CX555ES)	
*****			
	4-982-811-11	HOLDER (FL)	
		< CAPACITOR >	
C701	1-162-294-31	CERAMIC	0.001uF 10% 50V
C702	1-162-215-31	CERAMIC	47PF 5% 50V
C703	1-162-306-11	CERAMIC	0.01uF 20% 16V
C704	1-164-159-11	CERAMIC	0.1uF 50V
C706	1-162-282-31	CERAMIC	100PF 10% 50V
C707	1-162-282-31	CERAMIC	100PF 10% 50V
C708	1-162-282-31	CERAMIC	100PF 10% 50V
C709	1-162-288-31	CERAMIC	330PF 10% 50V
C710	1-124-584-00	ELECT	100uF 20% 10V
C711	1-164-159-11	CERAMIC	0.1uF 50V
C771	1-162-306-11	CERAMIC	0.01uF 20% 16V (CX555ES)
C772	1-126-924-11	ELECT	330uF 20% 6.3V (CX555ES)
C773	1-162-306-11	CERAMIC	0.01uF 20% 16V (CX555ES)
C774	1-126-924-11	ELECT	330uF 20% 6.3V (CX555ES)
C775	1-162-306-11	CERAMIC	0.01uF 20% 16V (CX555ES)
C776	1-126-924-11	ELECT	330uF 20% 6.3V (CX555ES)
C781	1-164-159-11	CERAMIC	0.1uF 50V
C791	1-124-584-00	ELECT	100uF 20% 10V
		< CONNECTOR >	
* CN701	1-568-839-11	SOCKET, CONNECTOR 23P	
		< DIODE >	
D701	8-719-046-39	LED SEL5821A-TP15 (GROUP1)	
D702	8-719-046-39	LED SEL5821A-TP15 (GROUP2)	
D703	8-719-046-39	LED SEL5821A-TP15 (GROUP3)	
D704	8-719-046-39	LED SEL5821A-TP15 (GROUP4)	
D705	8-719-046-39	LED SEL5821A-TP15 (HIT LIST)	
D706	8-719-046-39	LED SEL5821A-TP15 (GROUP5)	
D707	8-719-046-39	LED SEL5821A-TP15 (GROUP6)	
D708	8-719-046-39	LED SEL5821A-TP15 (GROUP7)	
D709	8-719-046-39	LED SEL5821A-TP15 (GROUP8)	
D710	8-719-046-44	LED SEL5221S-TP15 (STANDBY)	
D771	8-719-059-14	LED SID313BP-TP19 (ILLUMINATION) (CX555ES)	
D772	8-719-059-14	LED SID313BP-TP19 (ILLUMINATION) (CX555ES)	
D773	8-719-059-14	LED SID313BP-TP19 (ILLUMINATION) (CX555ES)	
D774	8-719-059-14	LED SID313BP-TP19 (ILLUMINATION) (CX555ES)	
D775	8-719-059-14	LED SID313BP-TP19 (ILLUMINATION) (CX555ES)	

Ref. No.	Part No.	Description	Remark
D780	8-719-911-19	DIODE 1SS133T-72 (CX555ES)	
D781	8-719-911-19	DIODE 1SS133T-72 (CX555ES)	
D782	8-719-911-19	DIODE 1SS133T-72 (CX555ES)	
		< LEAD >	
EB701	1-690-880-41	LEAD (WITH CONNECTOR)	
		< FLUORESCENT INDICATOR TUBE >	
FL701	1-517-861-11	INDICATOR TUBE, FLUORESCENT	
		< IC >	
IC701	8-759-498-92	IC MSM9202-03GS-K	
IC702	8-759-183-47	IC M66310FP	
IC703	8-749-014-66	IC NJL56H400A (REMOTE CONTROL RECEIVER)	
		< TRANSISTOR >	
Q701	8-729-900-80	TRANSISTOR BA1A4M-TP	
Q771	8-729-801-93	TRANSISTOR 2SD1387-34-TP (CX555ES)	
Q772	8-729-801-93	TRANSISTOR 2SD1387-34-TP (CX555ES)	
Q773	8-729-801-93	TRANSISTOR 2SD1387-34-TP (CX555ES)	
		< RESISTOR >	
R701	1-249-441-11	CARBON 100K 5% 1/4W	
R702	1-247-807-31	CARBON 100 5% 1/4W	
R703	1-247-807-31	CARBON 100 5% 1/4W	
R704	1-247-807-31	CARBON 100 5% 1/4W	
R705	1-247-807-31	CARBON 100 5% 1/4W	
R706	1-247-843-11	CARBON 3.3K 5% 1/4W	
R707	1-247-807-31	CARBON 100 5% 1/4W	
R708	1-247-807-31	CARBON 100 5% 1/4W	
R709	1-247-807-31	CARBON 100 5% 1/4W	
R711	1-249-411-11	CARBON 330 5% 1/4W	
R712	1-249-411-11	CARBON 330 5% 1/4W	
R713	1-249-413-11	CARBON 470 5% 1/4W	
R714	1-249-413-11	CARBON 470 5% 1/4W	
R721	1-249-415-11	CARBON 680 5% 1/4W	
R722	1-249-417-11	CARBON 1K 5% 1/4W	
R723	1-249-419-11	CARBON 1.5K 5% 1/4W	
R724	1-249-421-11	CARBON 2.2K 5% 1/4W	
R725	1-247-843-11	CARBON 3.3K 5% 1/4W	
R726	1-249-427-11	CARBON 6.8K 5% 1/4W	
R727	1-249-431-11	CARBON 15K 5% 1/4W	
R731	1-249-415-11	CARBON 680 5% 1/4W	
R732	1-249-417-11	CARBON 1K 5% 1/4W	
R733	1-249-419-11	CARBON 1.5K 5% 1/4W	
R734	1-249-421-11	CARBON 2.2K 5% 1/4W	
R735	1-247-843-11	CARBON 3.3K 5% 1/4W	
R736	1-249-427-11	CARBON 6.8K 5% 1/4W	
R742	1-249-415-11	CARBON 680 5% 1/4W	
R771	1-249-383-11	CARBON 1.5 5% 1/6W (CX555ES)	
R772	1-249-383-11	CARBON 1.5 5% 1/6W (CX555ES)	
R773	1-249-383-11	CARBON 1.5 5% 1/6W (CX555ES)	
R774	1-249-383-11	CARBON 1.5 5% 1/6W (CX555ES)	

**DISPLAY****D. MOTOR****D. SENSOR (IN)****D. SENSOR (OUT)****D. SWITCH****JACK****JOG**

Ref. No.	Part No.	Description	Remark
R775	1-247-772-00	CARBON 3.6 5%	1/4W (CX555ES)
R776	1-247-772-00	CARBON 3.6 5%	1/4W (CX555ES)
< SWITCH >			
S721	1-572-184-11	SWITCH, KEYBOARD (GROUP FILE)	
S722	1-572-184-11	SWITCH, KEYBOARD (GROUP8)	
S723	1-572-184-11	SWITCH, KEYBOARD (GROUP7)	
S724	1-572-184-11	SWITCH, KEYBOARD (GROUP6)	
S725	1-572-184-11	SWITCH, KEYBOARD (GROUP5)	
S726	1-572-184-11	SWITCH, KEYBOARD (GROUP1)	
S727	1-572-184-11	SWITCH, KEYBOARD (I/⏻)	
S728	1-570-157-51	SWITCH, SLIDE (TIMER)	
S731	1-572-184-11	SWITCH, KEYBOARD (GROUP2)	
S732	1-572-184-11	SWITCH, KEYBOARD (GROUP3)	
S733	1-572-184-11	SWITCH, KEYBOARD (GROUP4)	
S734	1-572-184-11	SWITCH, KEYBOARD (CONTINUE)	
S735	1-572-184-11	SWITCH, KEYBOARD (SHUFFLE)	
S736	1-572-184-11	SWITCH, KEYBOARD (PROGRAM)	
S737	1-572-184-11	SWITCH, KEYBOARD (REPEAT)	
S741	1-572-184-11	SWITCH, KEYBOARD (HIT LIST)	
S742	1-572-184-11	SWITCH, KEYBOARD (TIME/TEXT)	
*****			
	1-672-637-11	D. MOTOR BOARD *****	
*****			
	1-672-640-11	D. SENSOR (IN) BOARD *****	
*	4-985-300-01	HOLDER (P-T)  < PHOTO TRANSISTOR >	
Q81	8-729-926-31	PHOTO TRANSISTOR PT483F1	
*****			
	1-672-641-11	D. SENSOR (OUT) BOARD *****	
< LED>			
D81	8-719-055-84	LED GL528VS1 (DISC IN DETECT SENSOR)	
*****			
	1-672-634-11	D. SWITCH BOARD *****	
R82	1-249-415-11	CARBON 680 5%	1/4W
R83	1-249-417-11	CARBON 1K 5%	1/4W
R84	1-249-419-11	CARBON 1.5K 5%	1/4W
< SWITCH >			
SW83	1-571-300-21	SWITCH, ROTARY (DOOR OPEN/CLOSE)	
SW84	1-571-300-21	SWITCH, ROTARY (DOOR OPEN/CLOSE)	
*****			

Ref. No.	Part No.	Description	Remark
	1-672-629-11	JACK BOARD *****	
< CAPACITOR >			
C327	1-124-282-00	ELECT 22uF	20% 25V
C328	1-162-290-31	CERAMIC 470PF	10% 50V
C427	1-124-282-00	ELECT 22uF	20% 25V
C428	1-162-290-31	CERAMIC 470PF	10% 50V
C950	1-164-159-11	CERAMIC 0.1uF	50V
C951	1-164-159-11	CERAMIC 0.1uF	50V
C952	1-164-159-11	CERAMIC 0.1uF	50V
C953	1-104-665-11	ELECT 100uF	20% 10V
C954	1-164-159-11	CERAMIC 0.1uF	50V
< IC >			
IC901	8-749-921-12	IC GP1F32T (DIGITAL OUT OPTICAL)	
< JACK >			
* J901	1-764-188-11	JACK (SMALL TYPE) (DIA. 3.5) (CONTROL A1II)	
* J902	1-764-188-11	JACK (SMALL TYPE) (DIA. 3.5) (CONTROL A1II)	
J903	1-778-064-11	JACK, PIN 4P (2ND CD IN, LINE OUT)	
< COIL >			
L950	1-410-503-11	INDUCTOR 3.3uH	
< TRANSISTOR >			
Q950	8-729-620-05	TRANSISTOR 2SC2603TP-EF	
< RESISTOR >			
R339	1-215-485-00	METAL 470K	1% 1/4W
R340	1-215-405-00	METAL 220	1% 1/4W
R439	1-215-485-00	METAL 470K	1% 1/4W
R440	1-215-405-00	METAL 220	1% 1/4W
R950	1-249-425-11	CARBON 4.7K	5% 1/4W
R951	1-249-429-11	CARBON 10K	5% 1/4W
R952	1-249-393-11	CARBON 10	5% 1/4W
< SWITCH >			
S902	1-762-910-11	SWITCH, SLIDE (COMMAND MODE CD)	
*****			
	A-4724-646-A	JOG BOARD, COMPLETE (CX333ES)	
	A-4724-650-A	JOG BOARD, COMPLETE (CX555ES) *****	
< LED >			
D711	8-719-046-40	LED SEL5521C-TH8F (▷)	
D712	8-719-046-38	LED SEL5821A-TH8F (■)	
D713	8-719-033-06	LED SEL5920A-TP15 (MEGA CONTROL)	
D714	8-719-032-86	LED SEL5420E-TP15 (EASY PLAY)	
D715	8-719-033-06	LED SEL5920A-TP15 (MEGA CONTROL)	
D716	8-719-032-86	LED SEL5420E-TP15 (EASY PLAY)	
< RESISTOR >			
R715	1-249-407-11	CARBON 150	5% 1/4W

JOG	KEY	LED	L. SWITCH (A)
-----	-----	-----	---------------

Ref. No.	Part No.	Description	Remark
R716	1-249-409-11	CARBON 220 5%	1/4W
R717	1-249-401-11	CARBON 47 5%	1/4W
R718	1-249-401-11	CARBON 47 5%	1/4W
R719	1-249-429-11	CARBON 10K 5%	1/4W
R737	1-249-431-11	CARBON 15K 5%	1/4W
R743	1-249-417-11	CARBON 1K 5%	1/4W
R744	1-249-419-11	CARBON 1.5K 5%	1/4W
R745	1-249-421-11	CARBON 2.2K 5%	1/4W
R746	1-247-843-11	CARBON 3.3K 5%	1/4W
R747	1-249-427-11	CARBON 6.8K 5%	1/4W
R748	1-249-431-11	CARBON 15K 5%	1/4W
R752	1-249-415-11	CARBON 680 5%	1/4W
R753	1-249-417-11	CARBON 1K 5%	1/4W
R754	1-249-419-11	CARBON 1.5K 5%	1/4W
R755	1-249-421-11	CARBON 2.2K 5%	1/4W
R756	1-247-843-11	CARBON 3.3K 5%	1/4W
R757	1-249-427-11	CARBON 6.8K 5%	1/4W
R762	1-249-415-11	CARBON 680 5%	1/4W
R763	1-249-417-11	CARBON 1K 5%	1/4W
R764	1-249-419-11	CARBON 1.5K 5%	1/4W
R765	1-249-421-11	CARBON 2.2K 5%	1/4W
R766	1-247-843-11	CARBON 3.3K 5%	1/4W
R767	1-249-427-11	CARBON 6.8K 5%	1/4W

< ROTARY ENCODER >

RE701	1-475-543-11	ENCODER, ROTARY (⏪⏩ AMS ⏪⏩, PUSH ENTER)
RE702	1-475-543-11	ENCODER, ROTARY (DISC/CHARACTER, PUSH ENTER)

< SWITCH >

S706	1-570-855-11	SWITCH, SLIDE (FILTER)
S743	1-762-875-21	SWITCH, KEYBOARD (YES)
S744	1-762-875-21	SWITCH, KEYBOARD (+100)
S745	1-762-875-21	SWITCH, KEYBOARD (MENU/NO)
S751	1-762-875-21	SWITCH, KEYBOARD (CLEAR)
S752	1-762-875-21	SWITCH, KEYBOARD (FADER)
S753	1-762-875-21	SWITCH, KEYBOARD (CHECK)
S754	1-762-875-21	SWITCH, KEYBOARD (NO DELAY)
S755	1-762-875-21	SWITCH, KEYBOARD (MEMO SEARCH)
S756	1-762-875-21	SWITCH, KEYBOARD (X-FADE)
S761	1-762-875-21	SWITCH, KEYBOARD (EASY PLAY)
S762	1-762-875-21	SWITCH, KEYBOARD (MEGA CONTROL)
S763	1-762-875-21	SWITCH, KEYBOARD (■)
S764	1-762-875-21	SWITCH, KEYBOARD (■■)
S765	1-762-875-21	SWITCH, KEYBOARD (▷)

S766	1-762-875-21	SWITCH, KEYBOARD (≡ OPEN/CLOSE)
------	--------------	---------------------------------

\*\*\*\*\*

1-672-632-11	KEY BOARD
	*****

< CAPACITOR >

C792	1-126-925-11	ELECT 470uF 20%	10V
C821	1-164-159-11	CERAMIC 0.1uF	50V
C822	1-164-159-11	CERAMIC 0.1uF	50V

Ref. No.	Part No.	Description	Remark
		< CONNECTOR >	
* CNP203	1-568-944-11	PIN, CONNECTOR 6P (CX333ES)	
* CNP203	1-568-947-11	PIN, CONNECTOR 9P (CX555ES)	
* CNP702	1-568-954-11	PIN, CONNECTOR 5P (CX555ES)	
		< DIODE >	
D821	8-719-109-85	DIODE RD5.1ES-T2B2	
D822	8-719-109-85	DIODE RD5.1ES-T2B2	
D823	8-719-109-85	DIODE RD5.1ES-T2B2	
		< CONNECTOR >	
J821	1-785-945-11	CONNECTOR, DIN (KEYBOARD)	
		< NOISE FILTER >	
L821	1-424-122-11	FILTER, NOISE	
L822	1-424-122-11	FILTER, NOISE	
L823	1-424-122-11	FILTER, NOISE	
L824	1-424-122-11	FILTER, NOISE	
		< RESISTOR >	
R801	1-249-429-11	CARBON 10K 5%	1/4W (CX333ES)

\*\*\*\*\*

1-672-633-11	LED BOARD
	*****

* 4-976-473-01	HOLDER (LED-S)
----------------	----------------

< CAPACITOR >

C804	1-164-159-11	CERAMIC 0.1uF	50V
------	--------------	---------------	-----

< CONNECTOR >

* CN813	1-568-942-11	PIN, CONNECTOR 4P
---------	--------------	-------------------

< LED >

D802	8-719-071-41	LED SELS5923C-TP15	(INSIDE ILLUMINATION)
D803	8-719-071-42	LED SEL5723C-TP15	(INSIDE ILLUMINATION)
D804	8-719-072-76	LED SEL5E23C-TP15	(INSIDE ILLUMINATION)
D805	8-719-071-42	LED SEL5723C-TP15	(INSIDE ILLUMINATION)
D806	8-719-071-41	LED SELS5923C-TP15	(INSIDE ILLUMINATION)

< RESISTOR >

R805	1-249-401-11	CARBON 47 5%	1/4W
R806	1-249-399-11	CARBON 33 5%	1/4W
R807	1-249-401-11	CARBON 47 5%	1/4W

\*\*\*\*\*

1-672-642-11	L. SWITCH (A) BOARD
	*****

< SWITCH >

S81	1-571-300-21	SWITCH, ROTARY (LOADING DETECT)
-----	--------------	---------------------------------

\*\*\*\*\*



**L. SWITCH (B)**

**L.T. MOTOR**

**MAIN**

Ref. No.	Part No.	Description	Remark
	1-672-643-11	L. SWITCH (B) BOARD *****	
S82	1-771-604-11	SWITCH, DETECTION (LOADING) *****	
	1-672-636-11	L.T. MOTOR BOARD *****	
	A-4724-649-A	MAIN BOARD, COMPLETE (CX333ES)	
	A-4724-652-A	MAIN BOARD, COMPLETE (CX555ES) *****	
	7-685-871-01	SCREW +BVTT 3X6 (S)  < CAPACITOR >	
C201	1-163-102-00	CERAMIC CHIP 24PF	5% 50V
C202	1-163-038-00	CERAMIC CHIP 0.1uF	25V
C203	1-163-251-11	CERAMIC CHIP 100PF	5% 50V
C204	1-163-005-11	CERAMIC CHIP 470PF	10% 50V
C206	1-163-038-00	CERAMIC CHIP 0.1uF	25V
C207	1-124-997-11	ELECT 470uF	20% 10V
C208	1-163-038-00	CERAMIC CHIP 0.1uF	25V
C209	1-124-997-11	ELECT 470uF	20% 10V
C210	1-163-038-00	CERAMIC CHIP 0.1uF	25V
C211	1-102-945-00	CERAMIC 8.0PF	0.5PF 50V
C212	1-102-945-00	CERAMIC 8.0PF	0.5PF 50V
C213	1-163-038-00	CERAMIC CHIP 0.1uF	25V
C214	1-128-554-11	ELECT 330uF	20% 50V
C215	1-126-013-11	ELECT 1000uF	20% 16V
C217	1-163-251-11	CERAMIC CHIP 100PF	5% 50V
C301	1-163-038-00	CERAMIC CHIP 0.1uF	25V
C302	1-124-997-11	ELECT 470uF	20% 10V
C303	1-163-038-00	CERAMIC CHIP 0.1uF	25V
C305	1-124-997-71	ELECT 470uF	20% 10V
C306	1-102-947-00	CERAMIC 10PF	5% 50V
C307	1-126-059-11	ELECT 10uF	20% 50V
C308	1-126-059-11	ELECT 10uF	20% 50V
C309	1-136-802-11	FILM 0.015uF	5% 100V
C310	1-130-477-00	MYLAR 0.0033uF	5% 50V
C312	1-126-051-11	ELECT 47uF	20% 50V
C318	1-126-013-11	ELECT 1000uF	20% 16V
C319	1-163-038-00	CERAMIC CHIP 0.1uF	25V
C320	1-130-483-00	MYLAR 0.01uF	5% 50V
C321	1-130-483-00	MYLAR 0.01uF	5% 50V
C323	1-163-251-11	CERAMIC CHIP 100PF	5% 50V
C324	1-163-251-11	CERAMIC CHIP 100PF	5% 50V
C325	1-106-343-00	MYLAR 1000PF	5% 200V
C326	1-126-022-11	ELECT 47uF	20% 25V
C327	1-130-484-00	MYLAR 0.012uF	5% 50V
C329	1-126-962-11	ELECT 3.3uF	20% 50V
C331	1-163-038-00	CERAMIC CHIP 0.1uF	25V
C332	1-126-963-11	ELECT 4.7uF	20% 50V
C340	1-126-049-11	ELECT 22uF	20% 50V
C401	1-163-038-00	CERAMIC CHIP 0.1uF	25V
C402	1-124-997-11	ELECT 470uF	20% 10V
C403	1-163-038-00	CERAMIC CHIP 0.1uF	25V
C405	1-124-997-71	ELECT 470uF	20% 10V

Ref. No.	Part No.	Description	Remark
C406	1-102-947-00	CERAMIC 10PF	5% 50V
C407	1-126-059-11	ELECT 10uF	20% 50V
C408	1-126-059-11	ELECT 10uF	20% 50V
C409	1-136-802-11	FILM 0.015uF	5% 100V
C410	1-130-477-00	MYLAR 0.0033uF	5% 50V
C411	1-136-802-11	FILM 0.015uF	5% 100V
C412	1-126-059-11	ELECT 10uF	20% 50V
C413	1-126-059-11	ELECT 10uF	20% 50V
C415	1-126-059-11	ELECT 10uF	20% 50V
C418	1-126-013-11	ELECT 1000uF	20% 16V
C419	1-163-038-00	CERAMIC CHIP 0.1uF	25V
C420	1-130-483-00	MYLAR 0.01uF	5% 50V
C421	1-130-483-00	MYLAR 0.01uF	5% 50V
C423	1-163-251-11	CERAMIC CHIP 100PF	5% 50V
C424	1-163-251-11	CERAMIC CHIP 100PF	5% 50V
C425	1-106-343-00	MYLAR 1000PF	5% 200V
C426	1-126-022-11	ELECT 47uF	20% 25V
C427	1-130-484-00	MYLAR 0.012uF	5% 50V
C430	1-124-997-71	ELECT 470uF	20% 10V
C431	1-163-038-00	CERAMIC CHIP 0.1uF	25V
C440	1-126-049-11	ELECT 22uF	20% 50V
C501	1-104-665-11	ELECT 100uF	20% 10V
C502	1-163-038-00	CERAMIC CHIP 0.1uF	25V
C503	1-163-033-00	CERAMIC CHIP 0.022uF	50V
C504	1-104-665-11	ELECT 100uF	20% 10V
C505	1-163-033-00	CERAMIC CHIP 0.022uF	50V
C510	1-163-033-00	CERAMIC CHIP 0.022uF	50V
C511	1-163-033-00	CERAMIC CHIP 0.022uF	50V
C513	1-124-995-11	ELECT 220uF	20% 10V
C514	1-163-038-00	CERAMIC CHIP 0.1uF	25V
C515	1-124-995-11	ELECT 220uF	20% 10V
C516	1-163-038-00	CERAMIC CHIP 0.1uF	25V
C518	1-163-038-00	CERAMIC CHIP 0.1uF	25V
C519	1-163-038-00	CERAMIC CHIP 0.1uF	25V
C520	1-110-489-11	CAPACITOR 1F	5.5V
C521	1-163-038-00	CERAMIC CHIP 0.1uF	25V
C522	1-163-038-00	CERAMIC CHIP 0.1uF	25V
C530	1-136-165-00	FILM 0.1uF	5% 50V
C531	1-126-933-11	ELECT 100uF	20% 16V
C532	1-163-038-00	CERAMIC CHIP 0.1uF	25V
C534	1-163-038-00	CERAMIC CHIP 0.1uF	25V
C540	1-136-165-00	FILM 0.1uF	5% 50V
C541	1-126-933-11	ELECT 100uF	20% 16V
C542	1-163-038-00	CERAMIC CHIP 0.1uF	25V
C544	1-163-038-00	CERAMIC CHIP 0.1uF	25V
C550	1-136-173-00	FILM 0.47uF	5% 50V
C551	1-136-173-00	FILM 0.47uF	5% 50V
C552	1-109-953-11	ELECT 2.2uF	20% 50V
C553	1-163-038-00	CERAMIC CHIP 0.1uF	25V
C554	1-163-038-00	CERAMIC CHIP 0.1uF	25V
C555	1-163-038-00	CERAMIC CHIP 0.1uF	25V
C559	1-126-967-11	ELECT 47uF	20% 50V
C560	1-136-173-00	FILM 0.47uF	5% 50V
C580	1-126-960-11	ELECT 1uF	20% 50V (CX555ES)
C581	1-163-038-00	CERAMIC CHIP 0.1uF	25V (CX555ES)

**MAIN**

Ref. No.	Part No.	Description	Remark	Ref. No.	Part No.	Description	Remark
C582	1-104-665-11	ELECT	100uF 20% 10V (CX555ES)	D941	8-719-056-98	DIODE UDZ-TE-17-30B	
C583	1-163-038-00	CERAMIC CHIP	0.1uF	D942	8-719-069-56	DIODE UDZS-TE17-6.2B	
C591	1-104-665-11	ELECT	100uF 20% 10V (CX555ES)	D951	8-719-048-98	DIODE RB160L-40TE25	
C592	1-104-665-11	ELECT	100uF 20% 10V	D952	8-719-048-98	DIODE RB160L-40TE25	
C720	1-163-033-00	CERAMIC CHIP	0.022uF 50V	< IC >			
C730	1-163-033-00	CERAMIC CHIP	0.022uF 50V	IC201	8-759-527-07	IC CXD8735N-TP	
C740	1-163-033-00	CERAMIC CHIP	0.022uF 50V	IC202	8-759-361-58	IC CXA8055M	
C750	1-163-033-00	CERAMIC CHIP	0.022uF 50V	IC301	8-759-712-02	IC NJM2114D	
C760	1-163-033-00	CERAMIC CHIP	0.022uF 50V	IC302	8-759-712-02	IC NJM2114D	
C913	1-126-015-11	ELECT	3300uF 20% 16V	IC303	8-759-712-02	IC NJM2114D	
C914	1-126-015-11	ELECT	3300uF 20% 16V	IC401	8-759-712-02	IC NJM2114D	
C915	1-126-023-11	ELECT	100uF 20% 16V	IC402	8-759-712-02	IC NJM2114D	
C916	1-126-023-11	ELECT	100uF 20% 16V	IC403	8-759-712-02	IC NJM2114D	
C917	1-126-012-11	ELECT	470uF 20% 16V	IC501	8-759-598-80	IC MN101C12GSA1	
C918	1-126-012-11	ELECT	470uF 20% 16V	IC502	8-759-545-07	IC TMP87C447U-4A06 (CX555ES)	
C923	1-126-768-11	ELECT	2200uF 20% 16V	IC503	8-759-267-86	IC SN74HC00ANS (CX555ES)	
C924	1-126-768-11	ELECT	2200uF 20% 16V	IC504	8-759-463-99	IC M5M5256DFP-70XL	
C925	1-126-933-11	ELECT	100uF 20% 16V	IC505	8-759-822-38	IC LA6510	
C926	1-126-933-11	ELECT	100uF 20% 16V	IC506	8-759-822-38	IC LA6510	
C927	1-126-925-11	ELECT	470uF 20% 10V	IC910	8-759-231-53	IC M5F7805L	
C928	1-126-925-11	ELECT	470uF 20% 10V	IC911	8-759-604-90	IC M5F7907L	
C933	1-126-933-11	ELECT	100uF 20% 16V	IC920	8-759-605-00	IC TA7807S (LBSONY)	
C936	1-126-963-11	ELECT	4.7uF 20% 50V	IC921	8-759-094-53	IC TA7805S (LBSONY)	
C938	1-126-935-11	ELECT	470uF 20% 16V	IC930	8-759-173-39	IC NJU7201L50-T3	
C939	1-126-963-11	ELECT	4.7uF 20% 50V	IC931	8-759-821-93	IC LA5601	
C940	1-128-576-11	ELECT	100uF 20% 63V	< SHORT >			
C941	1-126-948-11	ELECT	100uF 20% 35V	JW001	1-216-295-00	SHORT	0
< CONNECTOR >				JW002	1-216-295-00	SHORT	0 (CX333ES)
* CN501	1-568-839-11	SOCKET, CONNECTOR 23P		< COIL >			
* CN502	1-568-839-11	SOCKET, CONNECTOR 23P		L201	1-410-375-11	INDUCTOR CHIP	3.3uH
* CN503	1-568-936-11	PIN, CONNECTOR 9P (CX555ES)		L202	1-410-375-11	INDUCTOR CHIP	3.3uH
* CN503	1-568-955-11	PIN, CONNECTOR 6P (CX333ES)		L204	1-414-234-22	INDUCTOR CHIP	0uH
CN504	1-506-469-11	PIN, CONNECTOR 4P		L205	1-414-234-22	INDUCTOR CHIP	0uH
CN505	1-506-469-11	PIN, CONNECTOR 4P		L206	1-414-234-22	INDUCTOR CHIP	0uH
* CN506	1-564-518-11	PLUG, CONNECTOR 3P		L207	1-414-234-22	INDUCTOR CHIP	0uH
* CN507	1-568-934-11	PIN, CONNECTOR 7P		L208	1-414-234-22	INDUCTOR CHIP	0uH
* CN508	1-568-953-41	PIN, CONNECTOR 4P		L209	1-414-234-22	INDUCTOR CHIP	0uH
* CN509	1-506-469-11	PIN, CONNECTOR 4P		L211	1-414-234-22	INDUCTOR CHIP	0uH
* CN510	1-564-509-11	PLUG, CONNECTOR 6P		< TRANSISTOR >			
* CN511	1-568-935-11	PIN, CONNECTOR 8P		Q325	8-729-027-38	TRANSISTOR	DTA144EKA-T146
* CN901	1-564-511-11	PLUG, CONNECTOR 8P		Q326	8-729-027-38	TRANSISTOR	DTA144EKA-T146
* CN902	1-564-508-11	PLUG, CONNECTOR 5P		Q328	8-729-027-38	TRANSISTOR	DTA144EKA-T146
* CN903	1-564-507-11	PLUG, CONNECTOR 4P		Q329	8-729-027-38	TRANSISTOR	DTA144EKA-T146
< DIODE >				Q332	8-729-027-38	TRANSISTOR	DTA144EKA-T146
D201	8-719-988-61	DIODE	1SS355TE-17	Q335	8-729-107-46	TRANSISTOR	2SC3624A-T1L15L16
D325	8-719-988-61	DIODE	1SS355TE-17	Q336	8-729-107-46	TRANSISTOR	2SC3624A-T1L15L16
D329	8-719-988-61	DIODE	1SS355TE-17	Q337	8-729-107-46	TRANSISTOR	2SC3624A-T1L15L16
D332	8-719-988-61	DIODE	1SS355TE-17	Q338	8-729-107-46	TRANSISTOR	2SC3624A-T1L15L16
D425	8-719-988-61	DIODE	1SS355TE-17	Q425	8-729-027-38	TRANSISTOR	DTA144EKA-T146
D501	8-719-988-61	DIODE	1SS355TE-17	Q426	8-729-027-38	TRANSISTOR	DTA144EKA-T146
D521	8-719-053-18	DIODE	1SR154-400TE-25	Q435	8-729-107-46	TRANSISTOR	2SC3624A-T1L15L16
D550	8-719-977-40	DIODE	UDZ-TE-17-13B	Q436	8-729-107-46	TRANSISTOR	2SC3624A-T1L15L16
D580	8-719-988-61	DIODE	1SS355TE-17 (CX555ES)	Q437	8-729-107-46	TRANSISTOR	2SC3624A-T1L15L16
D940	8-719-053-18	DIODE	1SR154-400TE-25	Q438	8-729-107-46	TRANSISTOR	2SC3624A-T1L15L16

Ref. No.	Part No.	Description	Remark	Ref. No.	Part No.	Description	Remark
Q521	8-729-030-08	TRANSISTOR DTC144VSA-TP		R334	1-216-097-00	RES, CHIP 100K 5%	1/10W
Q550	1-801-806-11	TRANSISTOR DTC144EKA-T146		R335	1-216-057-00	METAL CHIP 2.2K 5%	1/10W
Q551	8-729-027-38	TRANSISTOR DTA144EKA-T146					
Q552	8-729-027-38	TRANSISTOR DTA144EKA-T146		R336	1-216-057-00	METAL CHIP 2.2K 5%	1/10W
Q559	8-729-120-28	TRANSISTOR 2SC2412K-T-146-QR		R337	1-216-057-00	METAL CHIP 2.2K 5%	1/10W
				R338	1-216-057-00	METAL CHIP 2.2K 5%	1/10W
Q560	1-801-806-11	TRANSISTOR DTC144EKA-T146		R339	1-216-649-11	METAL CHIP 820 0.5%	1/10W
Q561	8-729-027-38	TRANSISTOR DTA144EKA-T146		R340	1-218-768-11	METAL CHIP 470K 0.5%	1/10W
Q562	8-729-027-38	TRANSISTOR DTA144EKA-T146					
Q570	8-729-900-53	TRANSISTOR DTC114EKA-T146		R401	1-216-639-91	METAL CHIP 330 0.5%	1/10W
Q571	8-729-900-53	TRANSISTOR DTC114EKA-T146		R402	1-216-639-91	METAL CHIP 330 0.5%	1/10W
				R403	1-216-633-91	METAL CHIP 180 0.5%	1/10W
Q572	8-729-027-23	TRANSISTOR DTA114EKA-T146		R404	1-216-633-91	METAL CHIP 180 0.5%	1/10W
Q573	8-729-027-23	TRANSISTOR DTA114EKA-T146		R405	1-216-607-11	METAL CHIP 15 0.5%	1/10W
Q574	8-729-027-23	TRANSISTOR DTA114EKA-T146					
Q576	8-729-027-23	TRANSISTOR DTA114EKA-T146		R406	1-216-607-11	METAL CHIP 15 0.5%	1/10W
Q580	8-729-900-53	TRANSISTOR DTC114EKA-T146 (CX555ES)		R407	1-216-607-11	METAL CHIP 15 0.5%	1/10W
				R408	1-216-607-11	METAL CHIP 15 0.5%	1/10W
Q581	8-729-120-28	TRANSISTOR 2SC2412K-T-146-QR (CX555ES)		R410	1-216-637-11	METAL CHIP 270 0.5%	1/10W
				R411	1-216-637-11	METAL CHIP 270 0.5%	1/10W
Q940	8-729-140-97	TRANSISTOR 2SB734-T-34					
		< RESISTOR >		R412	1-216-681-11	METAL CHIP 18K 0.5%	1/10W
				R413	1-216-681-11	METAL CHIP 18K 0.5%	1/10W
R201	1-216-033-00	METAL CHIP 220 5%	1/10W	R414	1-216-681-11	METAL CHIP 18K 0.5%	1/10W
R202	1-216-113-00	METAL CHIP 470K 5%	1/10W	R415	1-216-681-11	METAL CHIP 18K 0.5%	1/10W
R203	1-216-049-11	RES, CHIP 1K 5%	1/10W	R416	1-216-650-11	METAL CHIP 910 0.5%	1/10W
R204	1-216-061-00	METAL CHIP 3.3K 5%	1/10W				
R205	1-216-025-00	RES, CHIP 100 5%	1/10W	R417	1-216-657-11	METAL CHIP 1.8K 0.5%	1/10W
				R418	1-216-646-11	METAL CHIP 620 0.5%	1/10W
R207	1-216-025-00	RES, CHIP 100 5%	1/10W	R419	1-216-657-11	METAL CHIP 1.8K 0.5%	1/10W
R301	1-216-639-91	METAL CHIP 330 0.5%	1/10W	R420	1-216-673-11	METAL CHIP 8.2K 0.5%	1/10W
R302	1-216-639-91	METAL CHIP 330 0.5%	1/10W	R421	1-216-646-11	METAL CHIP 620 0.5%	1/10W
R303	1-216-633-91	METAL CHIP 180 0.5%	1/10W				
R304	1-216-633-91	METAL CHIP 180 0.5%	1/10W	R422	1-216-675-91	METAL CHIP 10K 0.5%	1/10W
				R423	1-216-675-91	METAL CHIP 10K 0.5%	1/10W
R305	1-216-607-11	METAL CHIP 15 0.5%	1/10W	R424	1-216-675-91	METAL CHIP 10K 0.5%	1/10W
R306	1-216-607-11	METAL CHIP 15 0.5%	1/10W	R425	1-218-760-11	METAL CHIP 220K 0.5%	1/10W
R307	1-216-607-11	METAL CHIP 15 0.5%	1/10W	R426	1-216-635-11	METAL CHIP 220 0.5%	1/10W
R308	1-216-607-11	METAL CHIP 15 0.5%	1/10W				
R309	1-216-675-91	METAL CHIP 10K 0.5%	1/10W	R427	1-216-635-11	METAL CHIP 220 0.5%	1/10W
				R428	1-216-673-11	METAL CHIP 8.2K 0.5%	1/10W
R310	1-216-637-11	METAL CHIP 270 0.5%	1/10W	R430	1-216-097-00	RES, CHIP 100K 5%	1/10W
R311	1-216-637-11	METAL CHIP 270 0.5%	1/10W	R431	1-216-097-00	RES, CHIP 100K 5%	1/10W
R312	1-216-681-11	METAL CHIP 18K 0.5%	1/10W	R435	1-216-057-00	METAL CHIP 2.2K 5%	1/10W
R313	1-216-681-11	METAL CHIP 18K 0.5%	1/10W				
R314	1-216-681-11	METAL CHIP 18K 0.5%	1/10W	R436	1-216-057-00	METAL CHIP 2.2K 5%	1/10W
				R437	1-216-057-00	METAL CHIP 2.2K 5%	1/10W
R315	1-216-681-11	METAL CHIP 18K 0.5%	1/10W	R438	1-216-057-00	METAL CHIP 2.2K 5%	1/10W
R316	1-216-650-11	METAL CHIP 910 0.5%	1/10W	R440	1-218-768-11	METAL CHIP 470K 0.5%	1/10W
R317	1-216-657-11	METAL CHIP 1.8K 0.5%	1/10W	R501	1-216-073-00	METAL CHIP 10K 5%	1/10W
R318	1-216-646-11	METAL CHIP 620 0.5%	1/10W				
R319	1-216-657-11	METAL CHIP 1.8K 0.5%	1/10W	R502	1-216-073-00	METAL CHIP 10K 5%	1/10W
				R503	1-216-097-00	RES, CHIP 100K 5%	1/10W
R320	1-216-673-11	METAL CHIP 8.2K 0.5%	1/10W	R504	1-216-073-00	METAL CHIP 10K 5%	1/10W
R321	1-216-646-11	METAL CHIP 620 0.5%	1/10W	R505	1-216-073-00	METAL CHIP 10K 5%	1/10W
R322	1-216-675-91	METAL CHIP 10K 0.5%	1/10W	R506	1-216-073-00	METAL CHIP 10K 5%	1/10W
R323	1-216-675-91	METAL CHIP 10K 0.5%	1/10W				
R324	1-216-675-91	METAL CHIP 10K 0.5%	1/10W	R507	1-216-073-00	METAL CHIP 10K 5%	1/10W
				R508	1-216-073-00	METAL CHIP 10K 5%	1/10W
R325	1-218-760-11	METAL CHIP 220K 0.5%	1/10W	R509	1-216-073-00	METAL CHIP 10K 5%	1/10W
R326	1-216-635-11	METAL CHIP 220 0.5%	1/10W	R510	1-216-069-00	METAL CHIP 6.8K 5%	1/10W
R327	1-216-635-11	METAL CHIP 220 0.5%	1/10W	R511	1-216-069-00	METAL CHIP 6.8K 5%	1/10W
R328	1-216-673-11	METAL CHIP 8.2K 0.5%	1/10W				
R330	1-216-097-00	RES, CHIP 100K 5%	1/10W	R513	1-216-073-00	METAL CHIP 10K 5%	1/10W
				R514	1-216-073-00	METAL CHIP 10K 5%	1/10W
R331	1-216-097-00	RES, CHIP 100K 5%	1/10W	R515	1-216-073-00	METAL CHIP 10K 5%	1/10W
R332	1-216-097-00	RES, CHIP 100K 5%	1/10W	R516	1-216-073-00	METAL CHIP 10K 5%	1/10W
R333	1-216-097-00	RES, CHIP 100K 5%	1/10W	R517	1-216-073-00	METAL CHIP 10K 5%	1/10W

**MAIN**

**POWER**

Ref. No.	Part No.	Description	Remark
R518	1-216-089-00	RES, CHIP	47K 5% 1/10W
R520	1-216-073-00	METAL CHIP	10K 5% 1/10W
R521	1-216-073-00	METAL CHIP	10K 5% 1/10W
R522	1-220-251-11	RES, CHIP	33 5% 1/2W
R530	1-216-078-00	RES, CHIP	16K 5% 1/10W
R531	1-216-103-00	METAL CHIP	180K 5% 1/10W
R532	1-216-103-00	METAL CHIP	180K 5% 1/10W
R533	1-216-101-00	METAL CHIP	150K 5% 1/10W
R534	1-220-227-11	RES, CHIP	1.2 10% 1/4W
R535	1-220-227-11	RES, CHIP	1.2 10% 1/4W
R536	1-216-001-00	METAL CHIP	10 5% 1/10W
R537	1-216-077-00	METAL CHIP	15K 5% 1/10W
R540	1-216-078-00	RES, CHIP	16K 5% 1/10W
R541	1-216-103-00	METAL CHIP	180K 5% 1/10W
R542	1-216-103-00	METAL CHIP	180K 5% 1/10W
R543	1-216-101-00	METAL CHIP	150K 5% 1/10W
R544	1-220-227-11	RES, CHIP	1.2 10% 1/4W
R545	1-220-227-11	RES, CHIP	1.2 10% 1/4W
R546	1-216-001-00	METAL CHIP	10 5% 1/10W
R547	1-216-077-00	METAL CHIP	15K 5% 1/10W
R550	1-216-057-00	METAL CHIP	2.2K 5% 1/10W
R551	1-216-097-00	RES, CHIP	100K 5% 1/10W
R552	1-216-049-11	RES, CHIP	1K 5% 1/10W
R553	1-216-097-00	RES, CHIP	100K 5% 1/10W
R554	1-216-101-00	METAL CHIP	150K 5% 1/10W
R555	1-216-065-00	RES, CHIP	4.7K 5% 1/10W
R556	1-220-227-11	RES, CHIP	1.2 10% 1/4W
R557	1-220-227-11	RES, CHIP	1.2 10% 1/4W
R558	1-216-025-00	RES, CHIP	100 5% 1/10W
R559	1-220-275-11	RES, CHIP	1.5K 5% 1/4W
R560	1-216-057-00	METAL CHIP	2.2K 5% 1/10W
R561	1-216-097-00	RES, CHIP	100K 5% 1/10W
R562	1-216-049-11	RES, CHIP	1K 5% 1/10W
R563	1-216-097-00	RES, CHIP	100K 5% 1/10W
R564	1-216-101-00	METAL CHIP	150K 5% 1/10W
R565	1-216-065-00	RES, CHIP	4.7K 5% 1/10W
R566	1-220-227-11	RES, CHIP	1.2 10% 1/4W
R567	1-220-227-11	RES, CHIP	1.2 10% 1/4W
R569	1-220-275-11	RES, CHIP	1.5K 5% 1/4W
R570	1-216-065-00	RES, CHIP	4.7K 5% 1/10W
R571	1-216-065-00	RES, CHIP	4.7K 5% 1/10W
R580	1-216-073-00	METAL CHIP	10K 5% 1/10W (CX555ES)
R581	1-216-073-00	METAL CHIP	10K 5% 1/10W (CX555ES)
R582	1-216-073-00	METAL CHIP	10K 5% 1/10W (CX555ES)
R583	1-216-065-00	RES, CHIP	4.7K 5% 1/10W (CX555ES)
R584	1-216-073-00	METAL CHIP	10K 5% 1/10W (CX555ES)
R591	1-216-025-00	RES, CHIP	100 5% 1/10W
R592	1-216-025-00	RES, CHIP	100 5% 1/10W
R593	1-216-025-00	RES, CHIP	100 5% 1/10W
R594	1-216-025-00	RES, CHIP	100 5% 1/10W
R720	1-216-069-00	METAL CHIP	6.8K 5% 1/10W
R730	1-216-069-00	METAL CHIP	6.8K 5% 1/10W
R740	1-216-069-00	METAL CHIP	6.8K 5% 1/10W
R750	1-216-069-00	METAL CHIP	6.8K 5% 1/10W

Ref. No.	Part No.	Description	Remark
R760	1-216-069-00	METAL CHIP	6.8K 5% 1/10W
R940	1-216-065-00	RES, CHIP	4.7K 5% 1/10W
R941	1-216-073-00	METAL CHIP	10K 5% 1/10W
R942	1-216-073-00	METAL CHIP	10K 5% 1/10W
R943	1-216-025-00	RES, CHIP	100 5% 1/10W
< VARIABLE RESISTOR >			
RV501	1-241-786-11	RES, ADJ, CARBON 22K	
< VIBRATOR >			
X201	1-760-955-11	VIBRATOR, CRYSTAL (45MHz)	
X501	1-579-175-11	VIBRATOR, CERAMIC (10MHz)	
X580	1-767-938-21	VIBRATOR, CERAMIC (7.28MHz) (CX555ES)	
*****			
	1-672-638-11	POWER BOARD	
*****			
< CAPACITOR >			
△C901	1-113-925-11	CERAMIC	0.01uF 20% 250V
C910	1-161-494-00	CERAMIC	0.022uF 25V
C911	1-126-767-11	ELECT	1000uF 20% 16V
C912	1-126-767-11	ELECT	1000uF 20% 16V
C920	1-161-494-00	CERAMIC	0.022uF 25V
C921	1-126-767-11	ELECT	1000uF 20% 16V
C922	1-126-767-11	ELECT	1000uF 20% 16V
C932	1-126-936-11	ELECT	3300uF 20% 16V
C937	1-126-960-11	ELECT	1uF 20% 50V
< CONNECTOR >			
* CN991	1-580-230-11	PIN, CONNECTOR (PC BOARD) 2P	
< DIODE >			
D901	8-719-911-19	DIODE	1SS133T-72
D910	8-719-024-99	DIODE	11ES2-NTA2B
D911	8-719-024-99	DIODE	11ES2-NTA2B
D912	8-719-024-99	DIODE	11ES2-NTA2B
D913	8-719-024-99	DIODE	11ES2-NTA2B
D920	8-719-200-77	DIODE	10E2N-TA2B
D921	8-719-200-77	DIODE	10E2N-TA2B
D922	8-719-200-77	DIODE	10E2N-TA2B
D923	8-719-200-77	DIODE	10E2N-TA2B
D930	8-719-911-19	DIODE	1SS133T-72
D931	8-719-911-19	DIODE	1SS133T-72
D932	8-719-210-21	DIODE	11EQS04-TA2B
D933	8-719-210-21	DIODE	11EQS04-TA2B
D934	8-719-210-21	DIODE	11EQS04-TA2B
D935	8-719-210-21	DIODE	11EQS04-TA2B
D939	8-719-911-19	DIODE	1SS133T-72
<GROUND TERMINAL >			
EB1	1-537-770-21	TERMINAL BOARD, GROUND	
EB2	1-537-770-21	TERMINAL BOARD, GROUND	
< LINE FILTER >			
△L901	1-424-485-11	FILTER, LINE	

The components identified by mark △ or dotted line with mark △ are critical for safety. Replace only with part number specified.	Les composants identifiés par une marque △ sont critiques pour la sécurité. Ne les remplacer que par une pièce portant le numéro spécifié.
--	--

Ref. No.	Part No.	Description	Remark
		< TRANSISTOR >	
Q930	8-729-620-05	TRANSISTOR 2SC2603TP-EF	
		< RESISTOR >	
R930	1-249-429-11	CARBON 10K 5% 1/4W	
R931	1-249-421-11	CARBON 2.2K 5% 1/4W	
R933	1-249-429-11	CARBON 10K 5% 1/4W	
R934	1-249-417-11	CARBON 1K 5% 1/4W	
		< RELAY >	
△ RY901	1-755-299-11	RELAY	
		< TRANSFORMER >	
△ T901	1-433-666-11	TRANSFORMER, POWER	
△ T902	1-433-663-11	TRANSFORMER, POWER	
*****			
	1-672-639-11	SENSOR (T) BOARD *****	
		< CONNECTOR >	
* CN81	1-506-486-11	PIN, CONNECTOR 7P	
CN82	1-506-481-11	PIN, CONNECTOR 2P	
CN83	1-506-481-11	PIN, CONNECTOR 2P	
		< PHOTO INTERRUPTER >	
IC81	8-749-924-18	PHOTO INTERRUPTER RPI-1391	
IC82	8-749-924-18	PHOTO INTERRUPTER RPI-1391	
IC83	8-749-924-18	PHOTO INTERRUPTER RPI-1391	
IC84	8-749-924-18	PHOTO INTERRUPTER RPI-1391	
		< RESISTOR >	
R81	1-249-416-11	CARBON 820 5% 1/4W	
R82	1-249-416-11	CARBON 820 5% 1/4W	
R83	1-249-416-11	CARBON 820 5% 1/4W	
R84	1-249-416-11	CARBON 820 5% 1/4W	
R85	1-249-415-11	CARBON 680 5% 1/4W	
*****			
		MISCELLANEOUS *****	
7	1-790-539-12	WIRE (FLAT TYPE) (23 CORE)	
8	1-773-183-11	WIRE (FLAT TYPE) (23 CORE)	
271	1-769-069-11	WIRE (FLAT TYPE) (16 CORE)	
△ 301	8-820-026-03	OPTICAL PICK-UP KSM-213BFN/C2NP	
△ CNP901	1-783-531-31	CORD, POWER	
M101	X-2646-110-3	T. T CHASSIS ASSY (MB) (FD) (SPINDLE)	
M102	X-2625-769-1	MOTIR GEAR ASSY (MB) (RP) (SLED)	
M81	A-4672-675-A	MOTOR ASSY (TABLE)	
M82	A-4672-675-A	MOTOR ASSY (LOADING)	
M83	X-4950-062-3	DOOR MOTOR ASSY	
△ T901	1-433-666-11	TRANSFORMER, POWER	
△ T902	1-433-663-11	TRANSFORMER, POWER	
*****			

Ref. No.	Part No.	Description	Remark
		***** HARDWARE LIST *****	
#1	7-685-646-79	SCREW +BVTP 3X8 TYPE2 N-S	
#2	7-682-548-09	SCREW (3X8)	
#3	7-685-650-79	SCREW +BVTP 3X16 TYPE2 N-S	
#4	7-685-871-01	SCREW +BVTT 3X6 (S)	
#5	7-685-645-79	SCREW +BVTP 3X6 TYPE2 N-S	
#6	7-685-533-19	SCREW +BTP 2.6X6 TYPE2 N-S	
#7	7-624-106-04	STOP RING 3.0, TYPE -E	
#8	7-682-948-01	SCREW +PSW 3X8	
#9	7-621-775-00	SCREW +B 2.6X3	
#10	7-621-772-21	SCREW +B 2X5	
#11	7-685-903-11	SCREW +PTPWH 3X6 (TYPE2)	
*****			
		ACCESSORIES & PACKING MATERIALS *****	
	1-418-254-11	REMOTE COMMANDER (RM-DX350) (CX555ES)	
	1-418-419-11	REMOTE COMMANDER (RM-DX300) (CX333ES)	
	1-776-263-11	CORD, CONNECTION (AUDIO)	
	1-777-172-11	CORD, CONNECTION (CONTROL A1) (Canadian)	
	3-866-362-11	MANUAL, INSTRUCTION (ENGLISH) (CX333ES)	
	3-866-362-21	MANUAL, INSTRUCTION (FRENCH) (CX333ES: Canadian)	
	3-866-363-11	MANUAL, INSTRUCTION (ENGLISH) (CX555ES: US)	
	3-866-363-21	MANUAL, INSTRUCTION (ENGLISH, FRENCH) (CX555ES: Canadian)	
	3-866-670-11	MANUAL, COMMONNESS INSTRUCTION (ENGLISH) (US)	
	3-866-670-21	MANUAL, COMMONNESS INSTRUCTION (ENGLISH, FRENCH, GERMAN, SPANISH, DUTCH, PORTUGUESE, SWEDISH, ITALIAN, CHINESE) (Canadian)	
	4-210-990-01	LID (RM-LJ301), BATTERY CASE (for RM-DX350) (CX555ES)	
	4-219-390-01	LABEL (DISC NUMBER)	
	4-981-643-01	COVER, BATTERY (for RM-DX300) (CX333ES)	
	4-984-086-01	BOOKLET (100)	

The components identified by mark △ or dotted line with mark △ are critical for safety. Replace only with part number specified.	Les composants identifiés par une marque △ sont critiques pour la sécurité. Ne les remplacer que par une pièce portant le numéro spécifié.
--	--

