

# CDP-CX50/CX571

## SERVICE MANUAL

*US Model*  
*Canadian Model*  
*AEP Model*  
*E Model*  
*Australian Model*  
CDP-CX50/CX571  
*UK Model*  
CDP-CX571



Photo : CDP-CX50

Model Name Using Similar Mechanism	NEW
CD Mechanism Type	CDM-46
Base Unit Type	KSM-213BFN/M-NP
Optical Pick-up Type	KSS-213B/S-N

### SPECIFICATIONS

#### Compact disc player

<b>Laser</b>	Semiconductor laser ( $\lambda = 780 \text{ nm}$ ) Emission duration: continuous
<b>Laser output</b>	Max 44.6 $\mu\text{W}$ * * This output is the value measured at a distance of 200 mm from the objective lens surface on the Optical Pick-up block with 7 mm aperture.
<b>Frequency response</b>	2 Hz to 20 kHz $\pm 1 \text{ dB}$
<b>Signal-to-noise ratio</b>	More than 100 dB
<b>Dynamic range</b>	More than 88 dB
<b>Harmonic distortion</b>	Less than 0.013 %
<b>Channel separation</b>	More than 95 dB

#### Output

	Jack type	Maximum output level	Load impedance
LINE OUT	Phono jacks	2 V (at 50 kilohms)	Over 10 kilohms

#### General

##### Power requirements

Where purchased	Power requirements
USA/Canada	120 V AC, 60 Hz
Australia/Singapore (CDP-CX50 only)	240 V AC, 50 Hz
UK	220 V - 230 V AC, 50/60 Hz
Australia/Singapore (CDP-CX571 only)	110 V - 120 V or 220 V - 240 V AC, adjustable, 50/60 Hz
Other countries	110 V - 120 V or 220 V - 240 V AC, adjustable, 50/60 Hz

**Power consumption** 12 W

**Dimensions (approx.) (w/h/d)**  
When the front cover is closed  
430  $\times$  182.5  $\times$  295 mm (17  $\times$  7 1/4  $\times$  11 5/8 in.) incl. projecting parts  
When the front cover is open  
430  $\times$  182.5  $\times$  414 mm (17  $\times$  7 1/4  $\times$  16 3/8 in.) incl. projecting parts

**Mass (approx.)** 5.0 kg (11 lbs 4 oz)

Design and specifications are subject to change without notice.

## COMPACT DISC PLAYER

# SONY®



## TABLE OF CONTENTS

<b>1. SERVICING NOTE</b> .....	3
<b>2. GENERAL</b> .....	4
<b>3. DISASSEMBLY</b>	
3-1. Front Panel .....	9
3-2. Illumination ASSY .....	9
3-3. Base Unit and Magnet Holder .....	10
3-4. CD Mechanism Section .....	11
<b>4. TEST MODE</b> .....	12
<b>5. MESHANICAL ADJUSTMENTS</b> .....	15
<b>6. ELECTRICAL ADJUSTMENTS</b> .....	18
<b>7. DIAGRAMS</b>	
7-1. Circuit Boards Location .....	20
7-2. Printed Wiring Board — BD Section — .....	21
7-3. Schematic Diagram — BD Section — .....	23
7-4. Printed Wiring Board — Main Section — .....	26
7-5. Schematic Diagram — Main Section — .....	29
7-6. Printed Wiring Board — Panel Section — .....	32
7-7. Schematic Diagram — Panel Section — .....	35
7-8. IC Pin Functions .....	38
7-9. IC Block Diagrams .....	44
<b>8. EXPLODED VIEWS</b>	
8-1. Case Section .....	46
8-2. Front Panel Section .....	47
8-3. Chassis Section .....	48
8-4. Mechanism Deck Section 1 (CDM-46) .....	49
8-5. Mechanism Deck Section 2 (CDM-46) .....	50
8-6. Optical Pick-up Section (KSM-213 BFN/M-NP) .....	51
<b>9. ELECTRICAL PARTS LIST</b> .....	52

## MODEL IDENTIFICATION

— BACK PANEL —

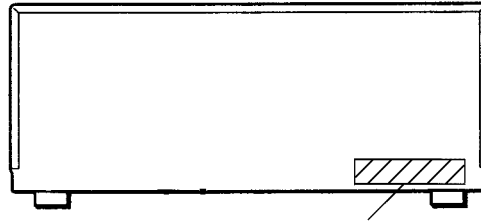

PARTS No.	MODEL
4-987-981-01	CX50 : US model
4-987-981-11	CX50 : Canadian model
4-987-981-21	CX50 : AEP, G model
4-987-981-31	CX50 : Australian model
4-987-981-41	CX50 : E model
4-987-981-51	CX50 : Singapore model
4-989-203-01	CX571 : US model
4-989-203-11	CX571 : Canadian model
4-989-203-21	CX571 : E model
4-989-203-31	CX571 : Singapore, Australian model
4-989-203-41	CX571 : AEP, G model
4-989-203-51	CX571 : UK model

### CAUTION

Use of controls or adjustments or performance of procedures other than those specified herein may result in hazardous radiation exposure.

The laser component in this product is capable of emitting radiation exceeding the limit for Class 1.

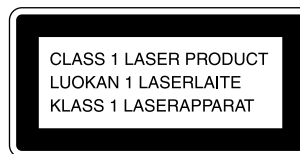

This appliance is classified as a CLASS 1 LASER product. The CLASS 1 LASER PRODUCT MARKING is located on the rear exterior.

CAUTION	; INVISIBLE LASER RADIATION WHEN OPEN. AVOID EXPOSURE TO BEAM.
ADVARSEL	; USYNLIG LASERSTRÅLING VED ÅBNING NÅR SIKKERHEDSÅFBRYDERE ER UDE AF FUNKTION. UNDGÅ UDSÆTTELSE FOR STRÅLING.
VARO!	; AVATTAESSA JA SUOJALUKITUS OHITETTAESSA OLET ALTIINA LASERSÄTELYLLE.
VARNING	; LASERSTRÅLING NÅR DENNA DEL ÄR ÖPPNAD OCH SPÄRREN ÄR URKOPPLAD.
ADVARSEL	; USYNLIG LASERSTRÅLING NÅR DEKSEL ÅPNES UNGÅ EKSPONERING FOR STRÅLEN.

This caution label is located inside the unit.

### For the customers in Canada

**CAUTION**  
 TO PREVENT ELECTRIC SHOCK,  
 DO NOT USE THIS POLARIZED AC  
 PLUG WITH AN EXTENSION  
 CORD, RECEPTACLE OR OTHER  
 OUTLET UNLESS THE BLADES  
 CAN BE FULLY INSERTED TO  
 PREVENT BLADE EXPOSURE.

# SECTION 1 SERVICING NOTE

## SAFETY CHECK-OUT

After correcting the original service problem, perform the following safety checks before releasing the set to the customer: Check the antenna terminals, metal trim, "metallized" knobs, screws, and all other exposed metal parts for AC leakage. Check leakage as described below.

### LEAKAGE

The AC leakage from any exposed metal part to earth Ground and from all exposed metal parts to any exposed metal part having a return to chassis, must not exceed 0.5 mA (500 microamperes). Leakage current can be measured by any one of three methods.

1. A commercial leakage tester, such as the Simpson 229 or RCA WT-540A. Follow the manufacturers' instructions to use these instruments.
2. A battery-operated AC milliammeter. The Data Precision 245 digital multimeter is suitable for this job.
3. Measuring the voltage drop across a resistor by means of a VOM or battery-operated AC voltmeter. The "limit" indication is 0.75 V, so analog meters must have an accurate low-voltage scale. The Simpson 250 and Sanwa SH-63Trd are examples of a passive VOM that is suitable. Nearly all battery operated digital multimeters that have a 2V AC range are suitable. (See Fig. A)

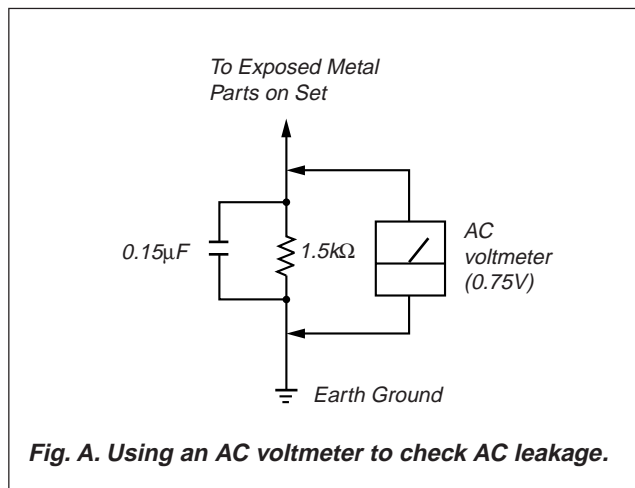

Fig. A. Using an AC voltmeter to check AC leakage.

### NOTES ON HANDLING THE OPTICAL PICK-UP BLOCK OR BASE UNIT

The laser diode in the optical pick-up block may suffer electrostatic breakdown because of the potential difference generated by the charged electrostatic load, etc. on clothing and the human body. During repair, pay attention to electrostatic breakdown and also use the procedure in the printed matter which is included in the repair parts. The flexible board is easily damaged and should be handled with care.

### NOTES ON LASER DIODE EMISSION CHECK

The laser beam on this model is concentrated so as to be focused on the disc reflective surface by the objective lens in the optical pick-up block. Therefore, when checking the laser diode emission, observe from more than 30 cm away from the objective lens.

### LASER DIODE AND FOCUS SEARCH OPERATION CHECK

Carry out the "S curve check" in "CD section adjustment" and check that the S curve waveform is output repeatedly.

### SAFETY-RELATED COMPONENT WARNING !!

COMPONENTS IDENTIFIED BY MARK  $\triangle$  OR DOTTED LINE WITH MARK  $\triangle$  ON THE SCHEMATIC DIAGRAMS AND IN THE PARTS LIST ARE CRITICAL TO SAFE OPERATION. REPLACE THESE COMPONENTS WITH SONY PARTS WHOSE PART NUMBERS APPEAR AS SHOWN IN THIS MANUAL OR IN SUPPLEMENTS PUBLISHED BY SONY.

### ATTENTION AU COMPOSANT AYANT RAPPORT À LA SÉCURITÉ!!

LES COMPOSANTS IDENTIFIÉS PAR UNE MARQUE  $\triangle$  SUR LES DIAGRAMMES SCHÉMATIQUES ET LA LISTE DES PIÈCES SONT CRITIQUES POUR LA SÉCURITÉ DE FONCTIONNEMENT. NE REMPLACER CES COMPOSANTS QUE PAR DES PIÈCES SONY DONT LES NUMÉROS SONT DONNÉS DANS CE MANUEL OU DANS LES SUPPLÉMENTS PUBLIÉS PAR SONY.

## SECTION 2 GENERAL

### LOCATION OF PARTS AND CONTROLS

#### Front Panel

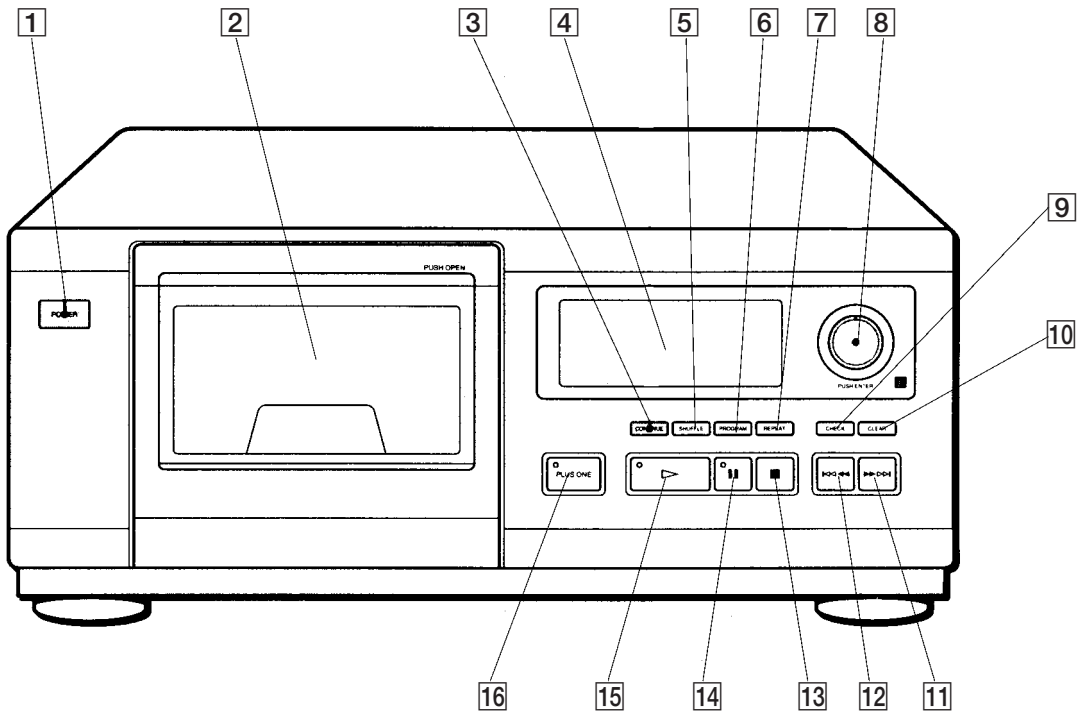

- 1 POWER switch
- 2 Front cover
- 3 CONTINUE button
- 4 Display window
- 5 SHUFFLE button
- 6 PROGRAM button
- 7 REPEAT button
- 8 DISC/PUSH ENTER button

- 9 CHECK button
- 10 CLEAR button
- 11 ►►►► button
- 12 ◀◀◀◀ button
- 13 ■ button
- 14 || button
- 15 ▷ button
- 16 PLUS ONE button

## Inserting CDs

You can insert up to 51 discs into this player.

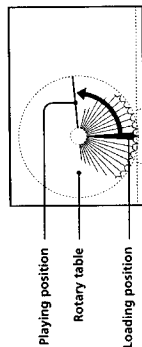
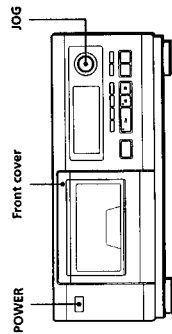

- 1 Press **POWER** to turn on the player.
- 2 Open the front cover by pushing the right edge of the cover.

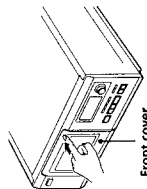

(Continued)

- 3 Turn the **JOG** dial until you find the disc slot where you want to insert a disc, while checking the disc number (written beside every slot and also indicated in the display).

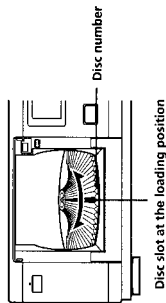

The disc number at the loading position appears in the display.\* As you turn the **JOG** dial, the disc number changes.

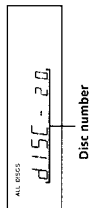

You can play the disc you want independently by using the **Plus One** function. When using this function, insert the disc into the **PLUS ONE** slot. For details, see "Playing Your Favorite Disc Independently" on page 14.

- \* If you have already inserted discs, the disc number at the playing position appears. When you turn the **JOG** dial, the displayed disc number changes to the one at the loading position.

- 4 Insert a disc with the label side facing right.

- Notes**
- Make sure you have inserted the disc into each slot at a right angle to the rotary table. If the disc is not put in straight, it may damage the player or the disc.
  - Make sure the rotary table comes to a complete stop before inserting or removing discs.

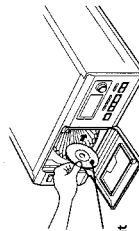

With the label side facing right

- 5 Repeat Steps 3 and 4 to insert more discs.
- 6 Close the front cover by pushing the right edge of the cover until it clicks.

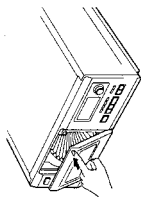

The rotary table turns and the disc slot at the loading position is set to the playing position. Always close the front cover except when you insert or remove discs.

**The supplied CD booklet holder helps you locate a disc**  
You can store up to 100 CD booklets.

### Notes

- Do not insert an empty 8 cm (3-inch) CD adaptor (CSA-8). It may damage the player.
- Do not attach anything such as seals or sleeves to CDs. It may damage the player or the disc.
- If you drop a disc into the player and the CD won't go into the slot correctly, consult your nearest Sony dealer.
- When transporting the player, remove all discs from the player.

### Removing CDs

After following Steps 1 to 3 of "Inserting CDs," on pages 5 – 6, remove the discs. Then close the front cover.

#### Note

The disc being played does not come to the loading position if you open the front cover during playback. (The disc number flashes in the display.)

If you want to remove the disc being played, push the JOG dial after opening the front cover. The disc comes to the loading position. Remove the disc after the rotary table comes to a complete stop.

### Locating a Specific Disc

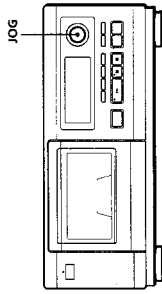

Turn the JOG dial until the disc number you want appears in the display. Push the JOG dial to start play.

### Specifying the Next Disc to Play

You can specify the next disc to play while playing a disc in Continuous or 1 DISC Shuffle Play mode.

While playing a disc, turn the JOG dial until the disc number you want appears in the display.

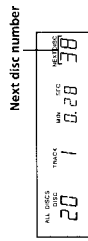

After the current disc is played, the next disc you have specified starts playing.

If you want to skip to the next disc right away, push the JOG dial while playing the current disc.

#### To cancel the disc you have specified

Press CONTINUE twice.

### Locating a Specific Track or a Point in a Track

You can quickly locate any track while playing a disc using the <<<< (AMS: Automatic Music Sensor) buttons. You can also locate a specific point in a track while playing a disc.

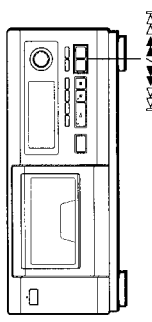

To locate	Press
the next or succeeding tracks	>>>> repeatedly until you find the track
the current or preceding tracks	<<<< repeatedly until you find the track
a point in a track while monitoring the sound	>>>> (forward) or <<<< (backward) and hold down until you find the point
a point in a track quickly by observing the display	>>>> (forward) or <<<< (backward) and hold down until you find the point during pause. You will not hear the sound during the operation.

#### Note

If "7" appears in the display, the disc has reached the end while you were pressing >>>>. Press <<<< to go back.

## Playing Repeatedly

You can play discs/tracks repeatedly in any play mode.

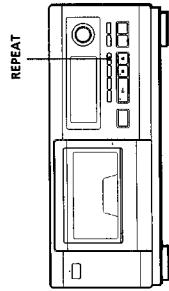

Press REPEAT while playing a disc. "REPEAT" appears in the display. The player repeats the discs/tracks as follows:

When the disc is played in	The player repeats
ALL DISCS Continuous Play (page 8)	All tracks on all discs
1 DISC Continuous Play (page 8)	All tracks on the current disc
ALL DISCS Shuffle Play (page 11)	The player does not repeat discs/tracks but keeps shuffling until you stop play whether or not you press REPEAT.
1 DISC Shuffle Play (page 11)	All tracks on the current disc in random order
Program Play (page 12)	The same program

### To cancel Repeat Play

Press REPEAT repeatedly until "REPEAT" disappears from the display.

### Repeating the current track

You can repeat only the current track.

While the track you want is being played, press REPEAT repeatedly until "REPEAT 1" appears in the display.

## Playing in Random Order (Shuffle Play)

You can have the player "shuffle" the tracks and play in random order. The player shuffles all the tracks on all discs or on the disc you specified.

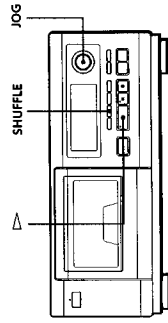

- 1 Press SHUFFLE to select ALL DISCS or 1 DISC Shuffle Play mode. Each time you press SHUFFLE, "ALL DISCS" or "1 DISC" appears in the display.

When you select	The player plays
ALL DISCS	All tracks on all discs in random order. The player keeps shuffling tracks until you stop play.*
1 DISC	All tracks on the specific disc in random order

\* The player may play the same track more than once.

- 2 When you want to specify the disc for 1 DISC Shuffle Play, turn the JOG dial until the disc number you want appears in the display.

- 3 Push the JOG dial or press  $\blacktriangleleft$ .

ALL DISCS or 1 DISC Shuffle Play starts. "LJ" appears in the display while the player is "shuffling" the discs or the tracks.

## Creating Your Own Program (Program Play)

You can arrange the order of the tracks and/or discs to create your own program and the program is stored automatically. A program can contain up to 32 "steps" — one "step" may contain a track or a whole disc.

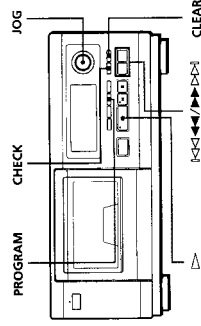

- 1 Press PROGRAM. If a program is already stored, the last step of the program appears in the display. When you want to erase the whole program, hold down CLEAR until "All Clr" appears in the display (see page 13).

- 2 Turn the JOG dial until the disc number you want appears in the display.

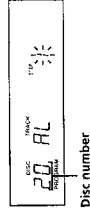

Disc number

- 3 To program a whole disc, skip this step. Press  $\blacktriangleleft$  until the track number you want appears in the display.

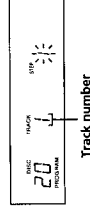

Track number

- 4 Push the JOC dial or press PROGRAM.

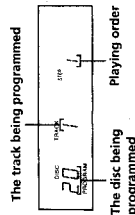

- 5 To program other discs/tracks, do the following:

To program	Repeat Steps
Other discs	2 and 4
Other tracks on the same disc	3 and 4
Other tracks on other discs	2 to 4

- 6 Press  $\square$  to start Program Play.

To cancel Program Play

Press CONTINUE.

**Lightbulb icon:** The program remains even after Program Play ends  
When you press  $\square$ , you can play the same program again.

**Lightbulb icon:** When you press PROGRAM during Continuous or Shuffle Play  
The program will be played after the current track.

**Lightbulb icon:** The program remains until you erase them  
If you replace discs, the programmed disc and track numbers remain. So, the player plays only the existing disc and track numbers. However, the disc and track numbers that are not found in the player or on the disc are deleted from the program, and the rest of the program is played in the programmed order.

### Checking the programmed order

You can check your program before or after you start playing.

Press CHECK.  
Each time you press this button, the display shows the disc and track number of each step in the programmed order. (When a whole disc is programmed as one step, "AL" appears instead of the track number.) After the last step in the program, the display shows "End" and returns to the original display.

### Changing the programmed order

You can change your program before you start playing.

To	You need to
Erase a track or disc	Press CHECK until the track or disc you do not want appears in the display, then press CLEAR
Erase the last track or disc in the program	Press CLEAR. Each time you press the button, the last track or disc will be cleared.
Add tracks or discs to the end of the program	Follow the programming procedure
Change the whole program completely	Hold down CLEAR until "All Clr" appears in the display to erase the whole program, then create a new program following the programming procedure

### Erasing the program stored in memory

- 1 Press PROGRAM in the stop mode.
- 2 Hold down CLEAR until "All Clr" appears in the display.

### Playing Your favorite Disc Independently (Plus One Play)

Use a programmed disc to play only one disc, even if you have programmed other discs/tracks in the program. When you press the button, the player automatically starts to play the programmed disc.



- 5 Repeat the programming procedure
- 7 Press CHECK until the programmed disc appears in the display

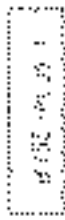

You can press the button to start to play the programmed disc.



- 3 Press the button to start to play the programmed disc.
- 4 Press the button to start to play the programmed disc. The display shows the track number of the programmed disc.

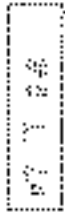

To cancel the Plus One Play  
Press the button to start to play the programmed disc. The display shows the track number of the programmed disc.

If you have programmed other discs/tracks in the program, you can press the button to start to play the programmed disc.

You can press the button to start to play the programmed disc.

Repeat  
If you have programmed other discs/tracks in the program, you can press the button to start to play the programmed disc.



## SECTION 3 DISASSEMBLY

**Note :** Follow the disassembly procedure in the numerical order given.

### 3-1. FRONT PANEL

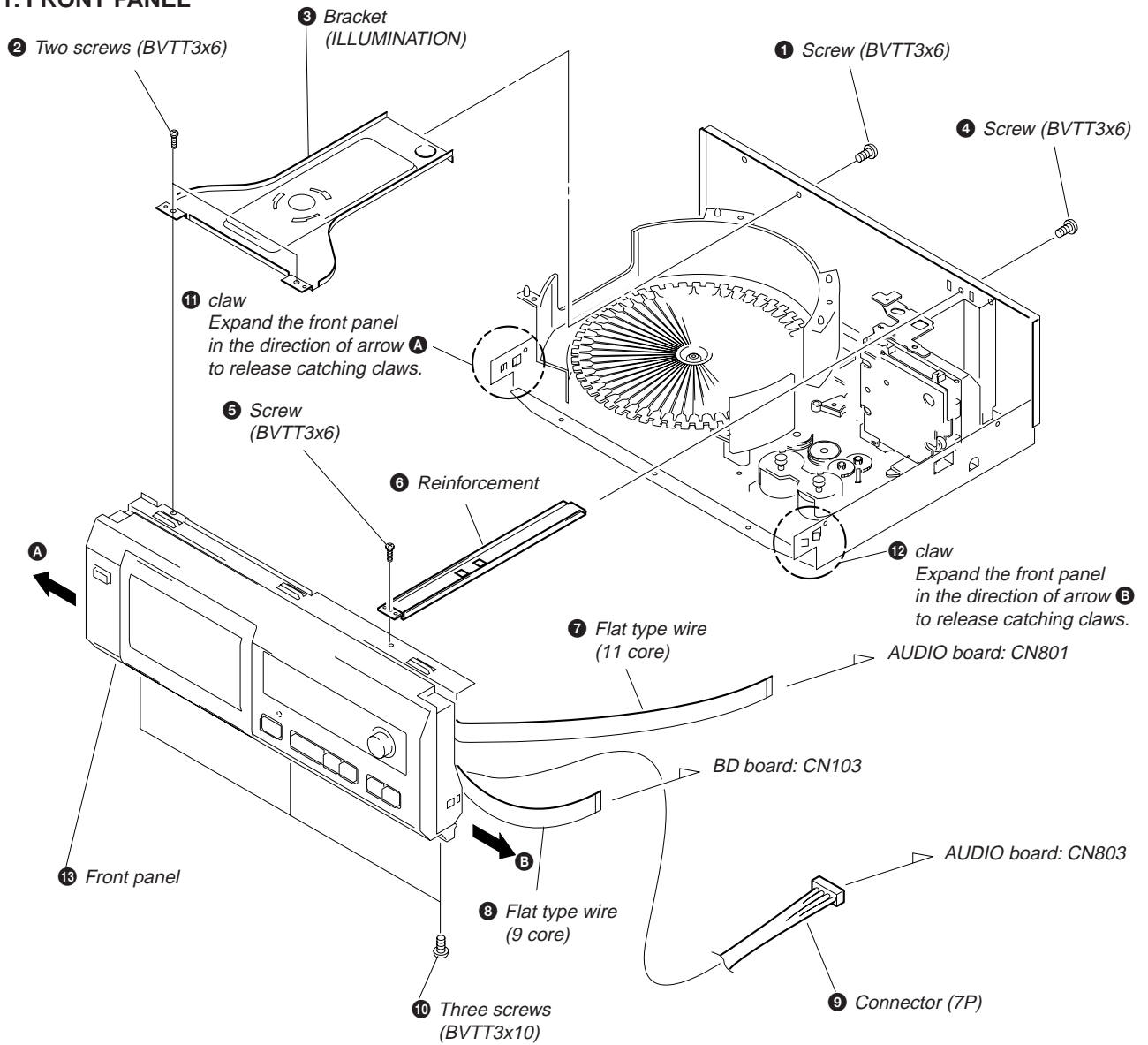

### 3-2. ILLUMINATION ASSY

While pressing arrows **A**, **B**, and **C**, rotate the illumination assembly in arrow direction **D** and remove it.

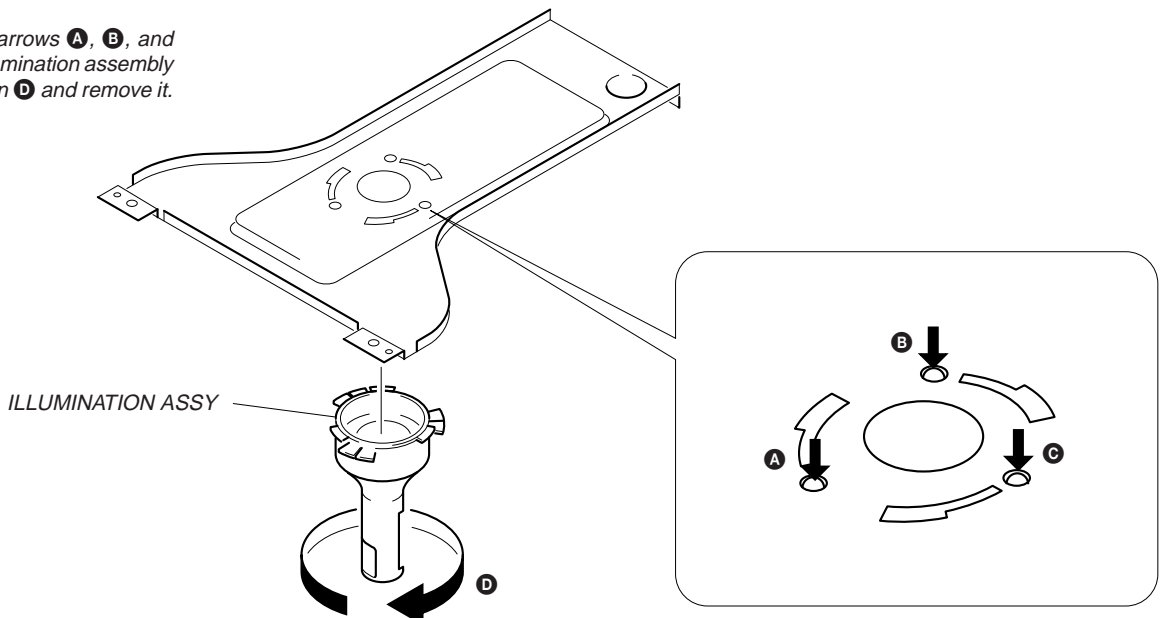

### 3-3. BASE UNIT AND MAGNET HOLDER

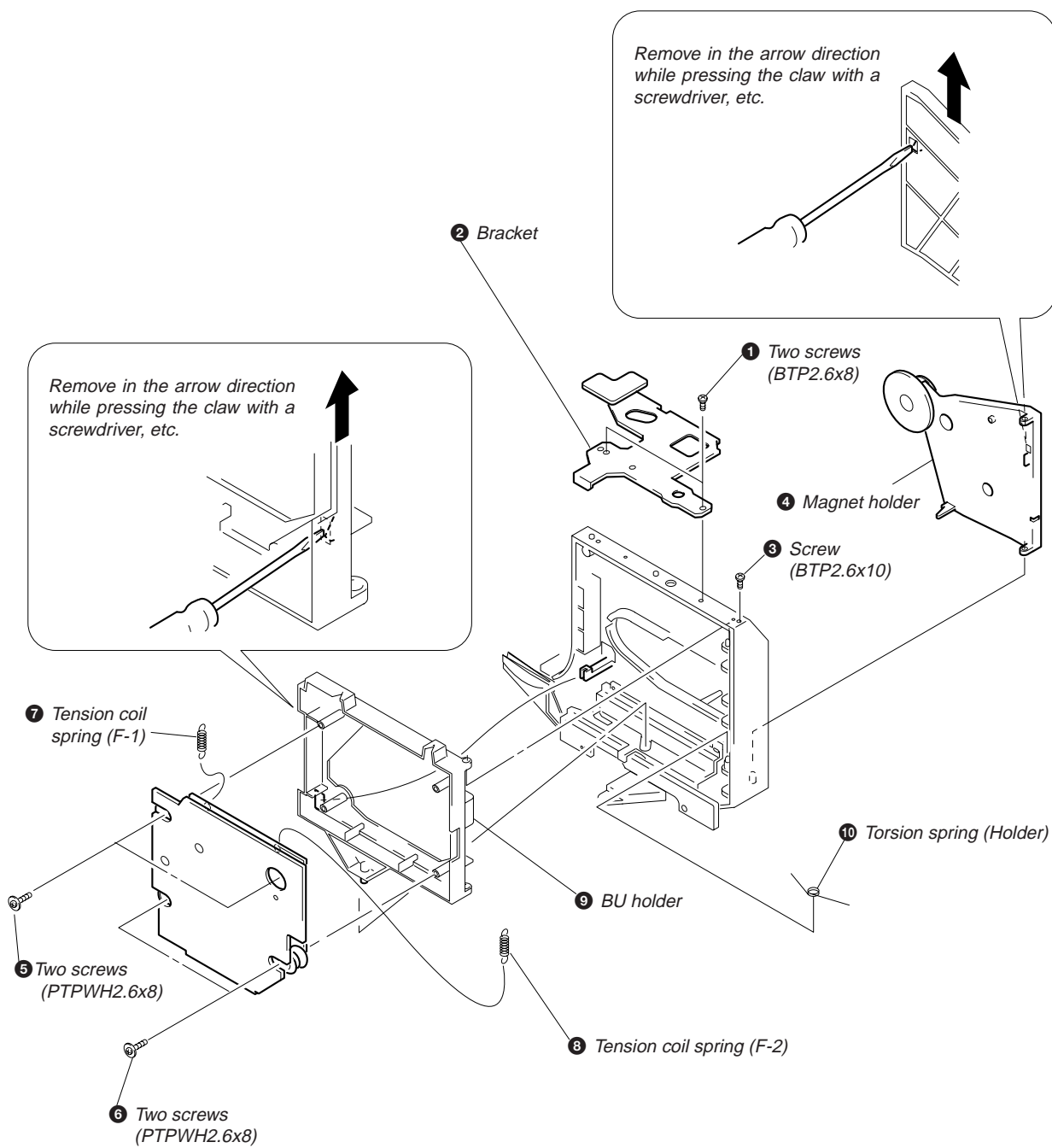

**3-4. CD MECHANISM SECTION**

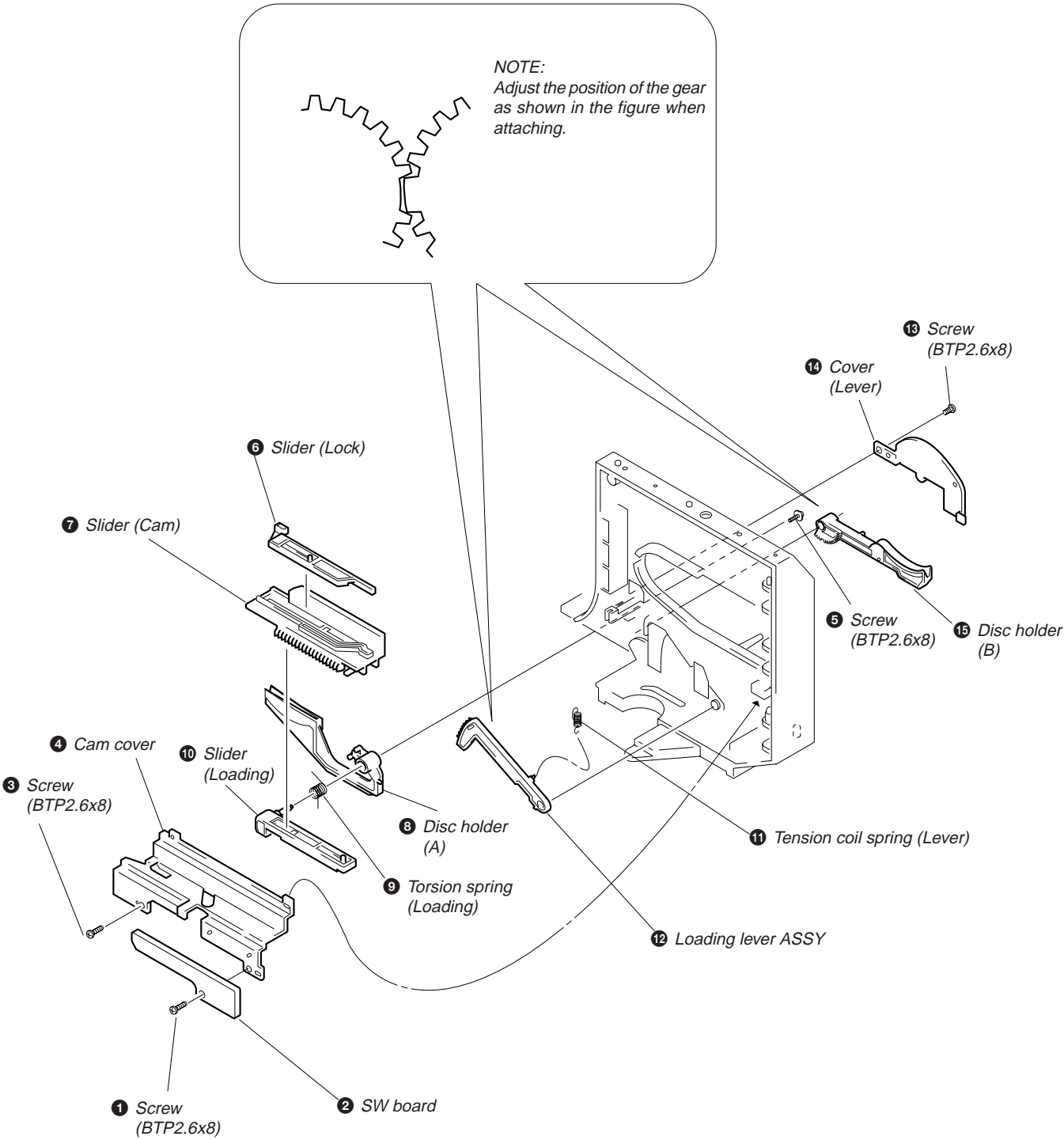

## SECTION 4 TEST MODE

### DISPLAY CHECK MODE

**NOTE:**

This will not work properly if the DISC is set to any slit.

1. Press the **POWER** button, turn ON the power, and set a CD in any slit.
2. Press the **POWER** button, and turn OFF the power.
3. While pressing the **CHECK** and **PLUS ONE** buttons together with the power OFF, press the **POWER** button and turn ON the power.
4. All the segments of the fluorescent indicator tube light up, and the **▷**, **||**, and **PLUS ONE** LEDs light up.
5. To exit the display check mode, press the **POWER** button or **■** button.

### ADJ MODE

1. Press the **POWER** button to turn the power ON.
2. Open the front cover, and press the **PLUS ONE** button.
3. Set the disc (YEDS-18 : 3-702-101-01) in the PLUS ONE slit.
4. Close the front cover, and chuck the disc.
5. Press the **POWER** button, and turn OFF the power.
6. Connect TP (TP301:ADJ) of the DISPLAY board and the ground with a lead wire.
7. Press the **POWER** button and turn ON the power.

The ADJ mode is set with the above.

Differences with normal mode

- No high speed search is performed during access
- Ignored even if GFS becomes L
- Ignored even if Q data cannot be read
- Spindle servo gain is set to 12 cm mode (Even with 8 cm disc)

The following special functions will work when certain functions are pressed in this mode.

#### Special functions in ADJ mode

(The ( ) buttons function only with the general purpose remote.)

Button	Function
(3)	Tracking servo , sled servo OFF
(8)	Tracking servo, sled servo ON
CHECK	S shape observation mode

### FLUORESCENT INDICATOR TUBE, LED ALL LIT, AND KEY CHECK MODE

Connect TP (TP302:AFADJ) of the DISPLAY board and the ground with the power OFF and press the **POWER** button.

The fluorescent indicator tube and LEDs all light up.

When a button is pressed, the left side of the indicator tube will show how many buttons have been pressed so far.

(However, buttons already pressed once will not be counted.)

The right side will show the numbers corresponding to the pressed buttons.

#### [ DISPLAY BOARD ] — CONDUCTOR SIDE —

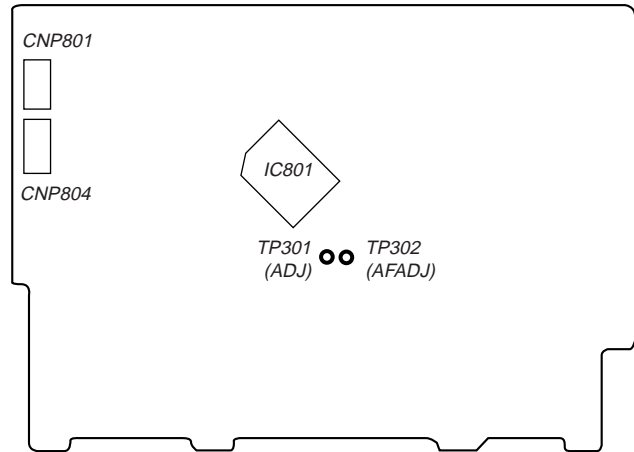

#### Buttons and Corresponding Button Numbers

Button	Button Number or Display
CONTINUE	1
SHUFFLE	2
PROGRAM	3
REPEAT	4
CHECK	5
CLEAR	6
PLUS ONE	7
▷	8 (The fluorescent indicator tube and LED near by (D801) are lit while pressed.)
	9 (The fluorescent indicator tube (segment check) is partially lit and LED near by (D802) is lit while pressed.)
■	10 (The fluorescent indicator tube is partially lit while pressed (grid check).)
◀◀ ◀	11
▶ ▶▶▶	12

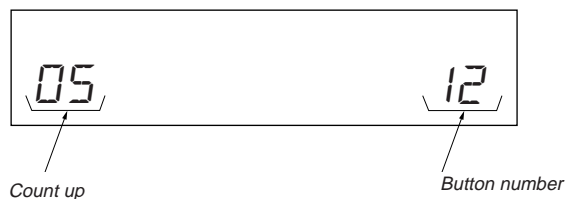

1. Grid check



2. Segment check

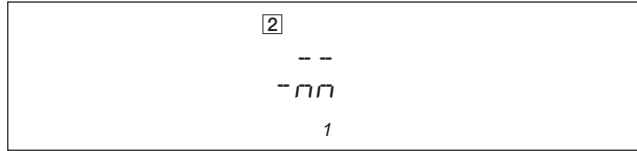

**Key Inputs Other than Buttons and How to Display**

Key input	Display
Rotate the JOG knob to the right	Fluorescent indicator tube block indicator lights up in the order of 1 → 2 → ...8 → 1.
Rotate the JOG knob to the left	Fluorescent indicator tube block indicator lights up in the order of 8 → 7 → ... 1 → 8.
Press the JOG knob (ENTER)	Fluorescent indicator tube block indicator goes OFF.
Door cover "Close"	[PLUS ONE] LED lights up
Door cover "Open"	[PLUS ONE] LED goes OFF

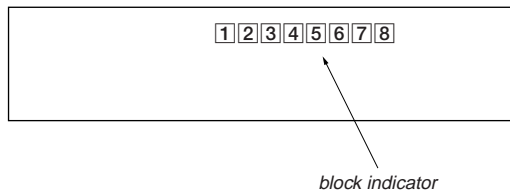

**AGING MODE**

- Mode which repeatedly changes and plays back discs automatically in the unit.
- It will repeat aging as long as no errors occur.
- If an error occurs during aging, it will stop all servos, motors, etc. instantaneously, display the error number, and stop operations. However, the stopping conditions differ according to whether the unit is equipped with the "self-protection function during errors" described later.  
The function serves to maintain the state of the unit when errors occur.

**Sequence of Aging Mode**

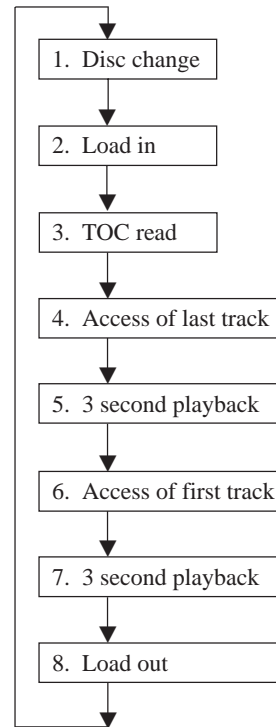

**Order of Disc Change**  
(1 cycle takes 3 minutes)

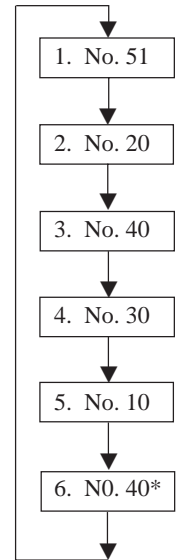

\* DISC No. 40 chucks twice during one cycle. To differentiate, the "[8]" on the block indicator of the fluorescent indicator tube will light up during the second chucking.

**Special Functions in Aging Mode**

There are some useful function in the aging mode.

- Disc setting mode\*1
- Switching of use/disuse of protection function in errors \*2
- Aging cycle count function \*3

\*1 Disc setting mode:

5 discs are set before setting the aging mode. This mode makes the setting of these discs more easy.

\*2 Switching of use/disuse of protection function in errors:

Function which voluntarily corrects errors which occur during normal operations by retries.  
If this function is not provided, all operations will be stopped without retiring. It is suitable for checking errors with low reproducibility.  
If this function is provided, and errors can be corrected by retries, aging will be continued without stopping.  
(The normal aging should be performed with "be".)

\*3 Aging cycle count function:

Functions which displays the number of agings carried out on the Fluorescent indicator tube in numbers. One aging cycle consists of six discs.

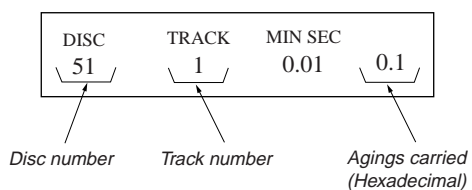





### Aging procedure:

Some operating method will be changed depending on if the following jig for the aging mode exists or not.





- Jig

Parts. No	Description
J-2501-123-A	Remote commander (For aging mode)

### With remote commander for aging mode:

1. Turn ON the power of the unit. Open the front cover.
2. Press the **AGING START** button of the remote commander for aging mode.
3. When the disc set mode is set, the  and  LEDs blink.
4. Rotate the JOG dial. The slits (No. 10, 20, 30, 40, 51) for setting the discs will come forward. Insert the discs into these slits. Do not set the discs in other slits.
5. Set the use/disuse of the self protection function in errors. Press the **REPEAT** button. When REPEAT is displayed on the fluorescent indicator tube, the self protection function during the error will become "Use".  
If the REPEAT display is OFF, it means that the function is not used. (Normally set to "Use" when performing aging.)
7. Press the  button.
8. The  LED blinks, the aging mode is set, and aging is started.
9. The aging cycle lasts 3 minutes. When problems occur during aging, the error number will be displayed on the fluorescent indicator tube, and the  LED will light up.  
(Refer to the following table for the details of the errors.)
10. Aging will be repeated as long as no errors occur.
11. After each aging cycle, the number displayed on the Fluorescent indicator tube will increase.
12. To end aging, press the **POWER** button

### Without remote commander for aging mode:

1. Turn ON the power of the unit. Open the front cover.
2. Press the **CLEAR**, , and  buttons in order.
3. When the disc set mode is set, the  and  LEDs blink.

The following procedure is the same as in the case "With remote commander for aging mode".

### Error Display

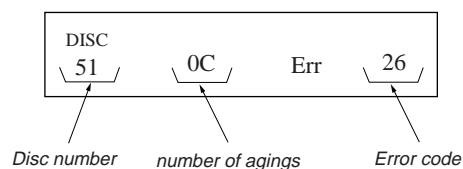

### Error code

Code number	Name	Contents
Err 01	DISC sensor check 1	No disc in the specified slit
Err 02	DISC sensor check 2	Disc in other slits
Err 03	—————	No function
Err 04	Table operation check 2	No table sensor input
Err 05	Loading operation check 1	Load in timeover
Err 06	Loading operation check 2	Load out timeover
Err *1	BU related check 1	Access timeover
Err *2	BU related check 2	High speed search NG
Err *3	BU related check 3	Q data read error
Err *4	BU related check 4	BU operation (From focus search to until signal can be read) timeover
Err *5	BU related check 5	GFS monitor error
Err *6	BU related check 6	Focus cannot be imposed by focus search

The \* numbers mean the following according to the state of the unit during aging

- 2 : From chucking to end of TOC read
- 3 : From end of TOC read to end of last track playback
- 4 : From end of last track playback to end of first track playback

## SECTION 5 MECHANICAL ADJUSTMENTS

To adjust the mechanism section, enter the mechanism section adjustment mode.  
For how to enter the mechanism section adjustment mode, refer to each adjustment section.

### DISC SENSOR ALIGNMENT

1. Make sure that there is no disc in the unit.
2. Connect an oscilloscope to TP501 of the AUDIO board.

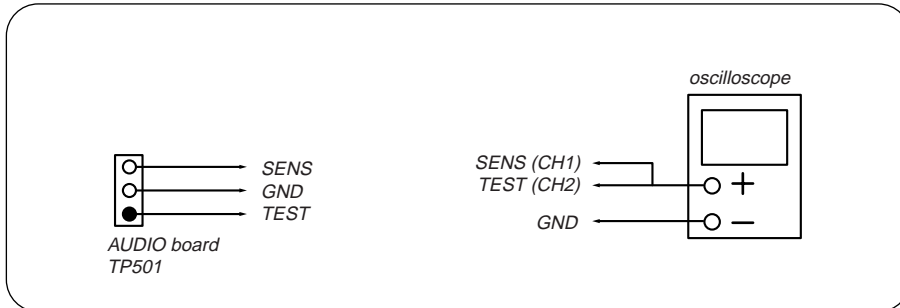

3. While pressing the **CLEAR** and **PLUS ONE** buttons at the same time and turn ON the power.

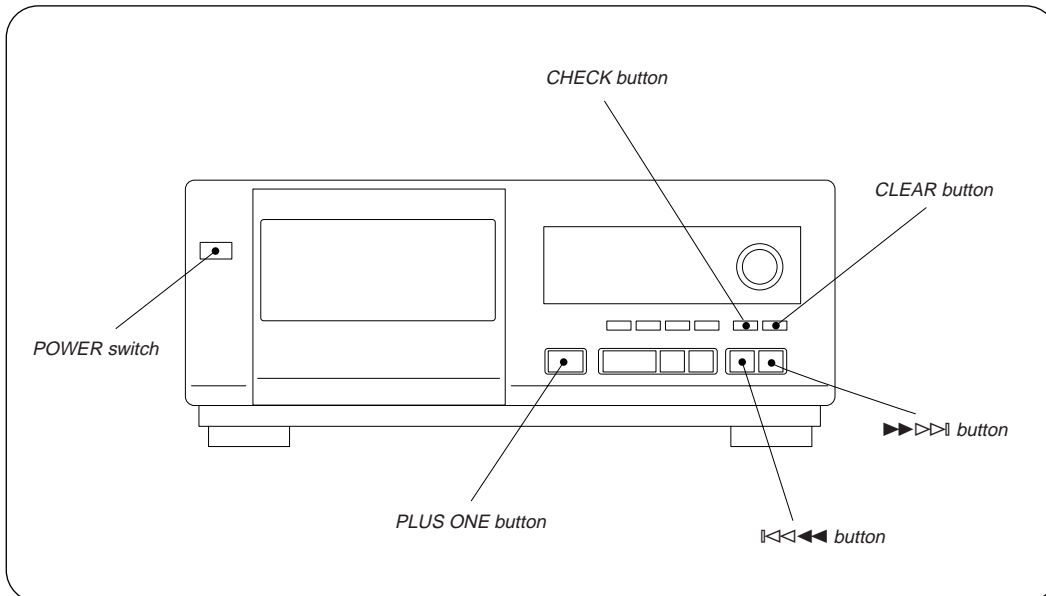

4. The fluorescent indicator tube shows as follows, and the mechanism section adjustment mode is set.

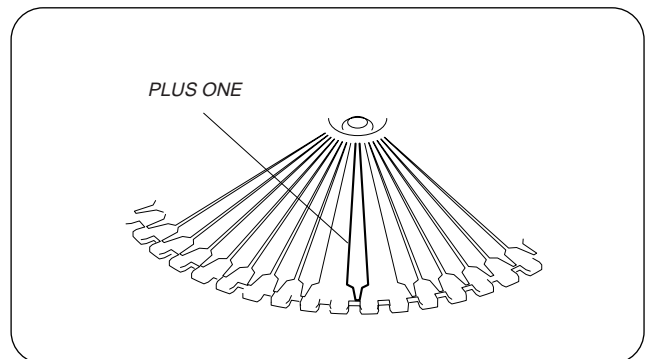
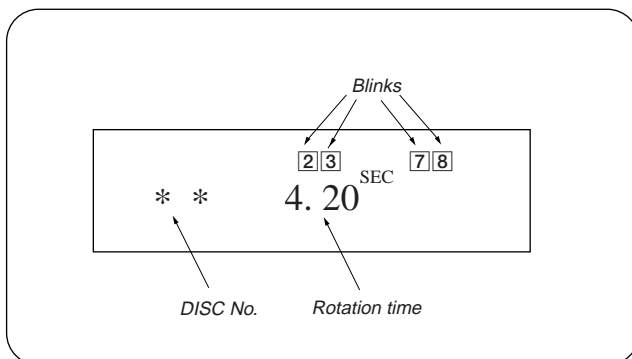

5. The disc table rotates in the counterclockwise direction. The disc table rotation time is displayed with "PLUS ONE" slit as a measuring point. ("LEFT" is displayed initially.)
6. Measure the waveform of the oscilloscope when the disc table is rotating.

7. Move the holder (sensor) center so that the flat portion center at the top of the SENS (CH1) input waveform and the “H” center of TEST (CH2) coincide.

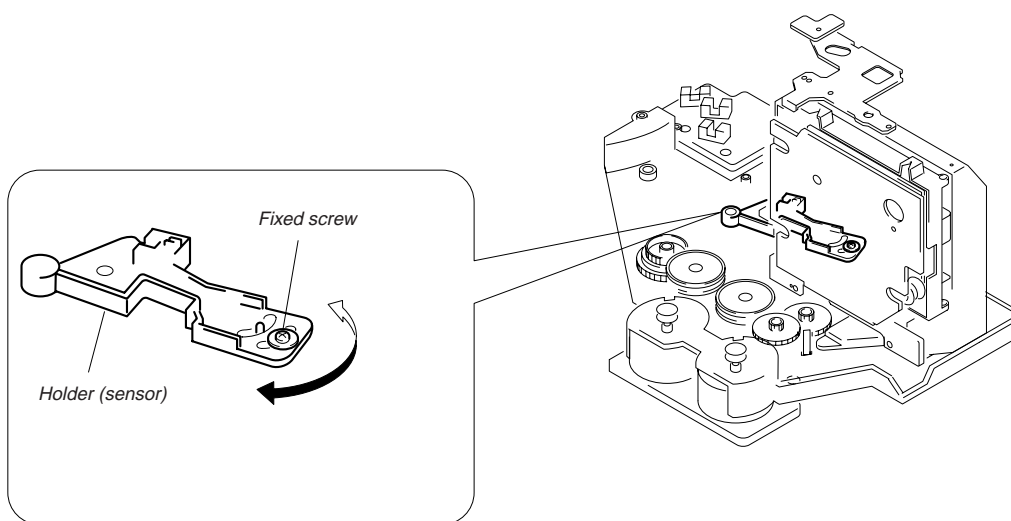
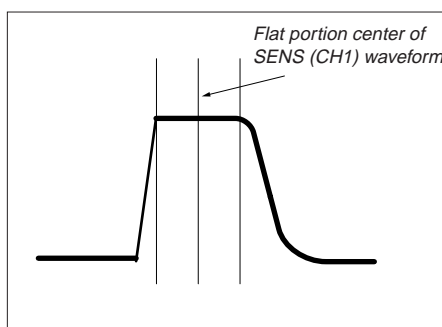
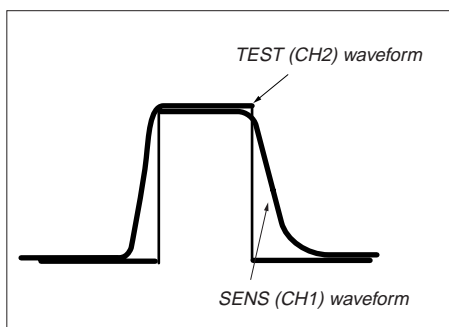

8. Tighten the fixed screw to fix the disc table, then press the **CLEAR** button.
9. The disc table rotates in the clockwise direction. Measure the waveform and make sure that the flat portion center at the top of the SENS (CH1) input waveform and the “H” center of TEST (CH2) coincide.
10. If the adjustment is not successful, press the **CLEAR** button to rotate the disc table in the counterclockwise direction, and perform steps 6 to 9.
- Note:** During the adjustment mode, the rotational direction is switched each time the **CLEAR** button is pressed. Immediately after the button is pressed, “LEFT” or “right” is displayed to notify of the rotational direction. Pressing the **CHECK** button enters the loading mode which will be described later. Pressing the **CLEAR** button rotates the disc table again.



## MAGNET ASSY ALIGNMENT

1. Check that there is no disc in the unit and then turn ON the power. Open the door, and set a disc in the PLUS ONE slit.
2. Turn OFF the power, close the door, and while pressing the **CLEAR** and **PLUS ONE** buttons simultaneously, turn ON the power again.
3. Press the **CHECK** button, and set the loading mode.
4. Press the **▶▶▶▶▶▶▶▶▶▶** button and chuck the disc.
5. Adjust the magnet assembly and magnet holder so that  $A=B$  as shown in the figure.

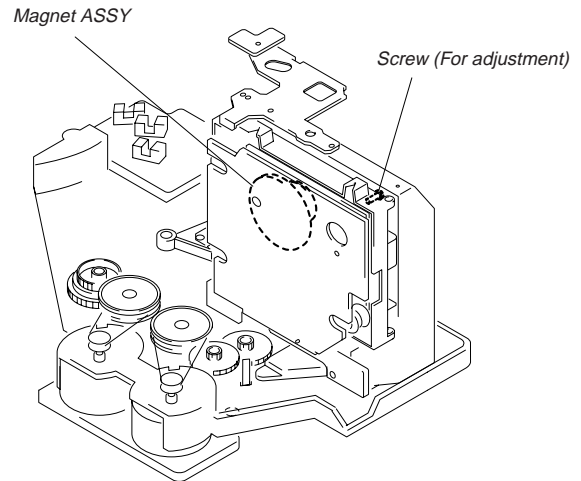
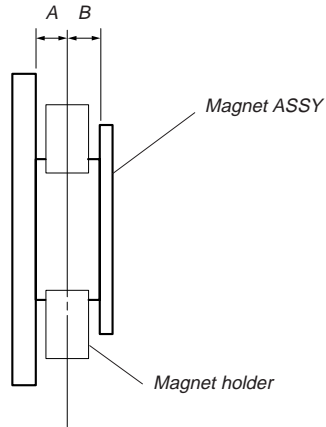

## DISC HOLDER A ALIGNMENT

1. Check that there is no disc in the unit and then turn ON the power. Open the door, and set a disc in the PLUS ONE slit.
2. Turn OFF the power, close the door, and while pressing the **CLEAR** and **PLUS ONE** buttons simultaneously, turn ON the power again.
3. Press the **CHECK** button, and set the loading mode.
4. Press the **▶▶▶▶▶▶▶▶▶▶** button and chuck the disc.
5. Press **▶▶▶▶▶▶▶▶▶▶** or **▶▶▶▶▶▶▶▶▶▶** button to stop the disc holder A slightly away from the disc.
6. Rotate and adjust the adjusting screw so that the center of the disc and that of the disc holder coincide.

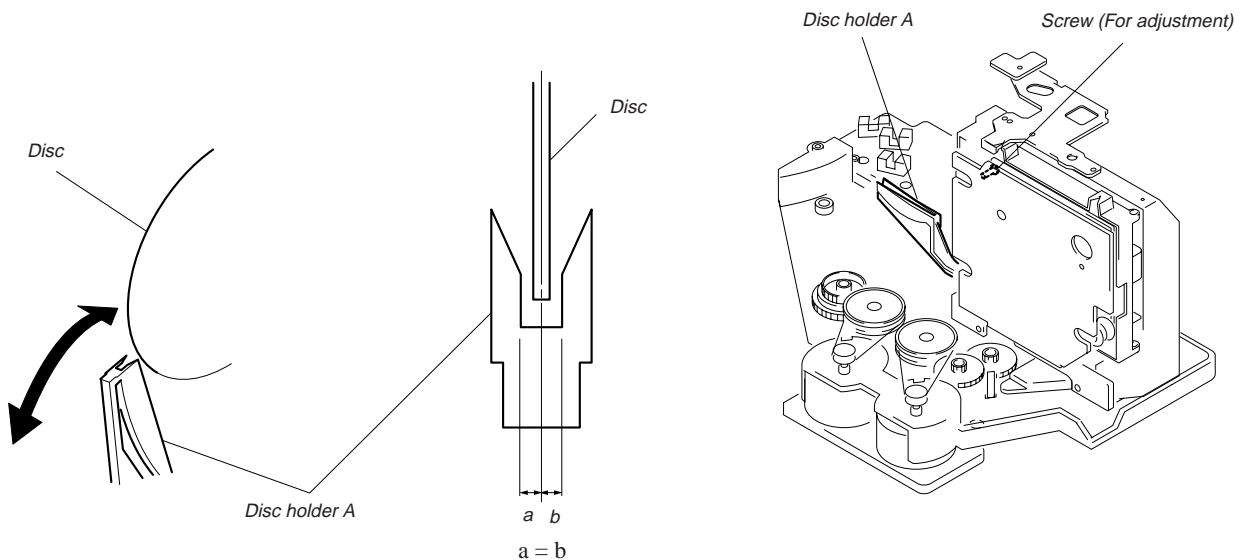

## SECTION 6 ELECTRICAL ADJUSTMENTS

**Note :**

1. CD Block is basically designed to operate without adjustment. Therefore, check each item in order given.
2. Use YEDS-18 disc (3-702-101-01) unless otherwise indicated.
3. Use an oscilloscope with more than 10MΩ impedance.
4. Clean the object lens by an applicator with neutral detergent when the signal level is low than specified value with the following checks.

**S Curve Check**

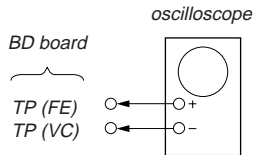

**Procedure :**

1. Press the **POWER** button and turn ON the power supply.
2. Open the front cover, and press the **PLUS ONE** button.
3. Set the disc (YEDS-18) into the "PLUS ONE" slit.
4. Close the front cover, and chuck the disc.
5. Press the **POWER** button and turn OFF the power.
6. Connect the oscilloscope to TP (FE) of the BD board.
7. Connect TP (ADJ) of the DISPLAY board and the ground with a lead wire.
8. Press the **POWER** button and turn ON the power.
9. The first track will be played back automatically. When the **CHECK** button is pressed, "S J1" will be displayed on the fluorescent indicator tube, and focus search will be repeated.
10. Check the oscilloscope waveform (S-curve) is symmetrical between A and B. And confirm peak to peak level within  $1.8 \pm 0.6$  Vp-p.

S-curve waveform

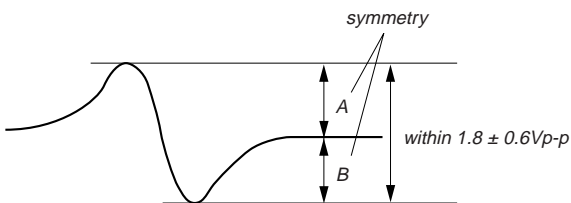

11. Turn OFF the power, and remove the lead wire connected at step 7.

- Note :**
- Try to measure several times to make sure than the ratio of A : B or B : A is more than 10 : 7.
  - Take sweep time as long as possible and light up the brightness to obtain best waveform.

**RF Level Check**

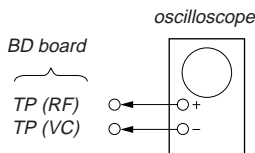

**Procedure :**

1. Press the **POWER** button and turn ON the power supply.
2. Open the front cover, and press the **PLUS ONE** button.
3. Set the disc (YEDS-18) into the "PLUS ONE" slit.
4. Close the front cover, and chuck the disc.
5. Press the **POWER** button and turn OFF the power.
6. Connect the oscilloscope to TP (RF) of the BD board.
7. Connect TP (ADJ) of the DISPLAY board and the ground with a lead wire.
8. Press the **POWER** button and turn ON the power.
9. Playback the fifth track of the disc.

10. Confirm that oscilloscope waveform is clear and check RF signal level is correct or not.
11. Turn OFF the power, and remove the lead wire connected at step 7.

**Note :** A clear RF signal waveform means that the shape "∅" can be clearly distinguished at the center of the waveform.

RF signal waveform

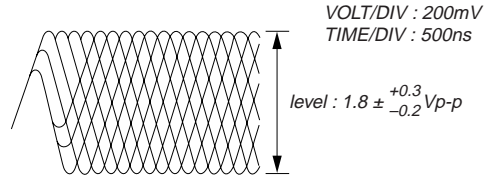

**E-F Balance (Traverse) Check**

The procedure for this checking method differs for when a general remote control unit is used and not used.

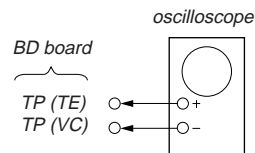

**When a general remote commander is used:**

1. Press the **POWER** button and turn ON the power supply.
2. Open the front cover, and press the **PLUS ONE** button.
3. Set the disc (YEDS-18) into the "PLUS ONE" slit.
4. Close the front cover, and chuck the disc.
5. Press the **POWER** button and turn OFF the power.
6. Connect the oscilloscope to TP (TE) of the BD board.
7. Connect TP (ADJ) of the DISPLAY board and the ground with a lead wire.
8. Press the **POWER** button and turn ON the power.
9. Playback the fifth track of the disc.
10. Press the **3** button on the remote commander. (The tracking servo and the sledding servo are turned OFF.)
11. Check the level B of the oscilloscope's waveform and the A (DC voltage) of the center of the Traverse waveform. Confirm the following :  
 $A/B \times 100 = \text{less than } \pm 10\%$

Traverse waveform

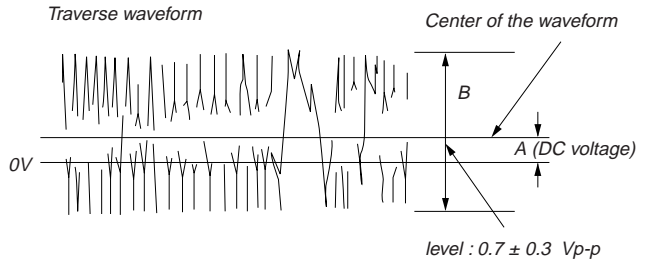

12. Press the **8** button on the remote control unit. (The tracking servo and sledding servo are turned ON.) Confirm the C (DC voltage) is almost equal to the A (DC voltage) is step 11.

Traverse waveform

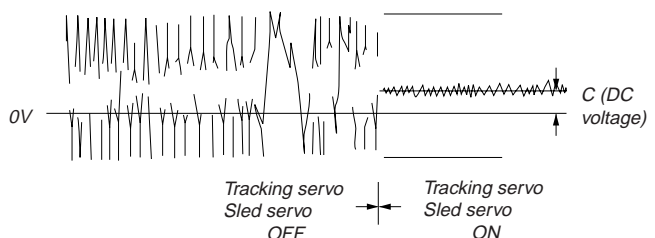

13. Turn OFF the power, and remove the lead wire connected at step 7.

## SECTION 7 DIAGRAMS

### 7-1. CIRCUIT BOARDS LOCATION

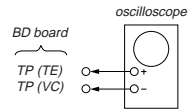
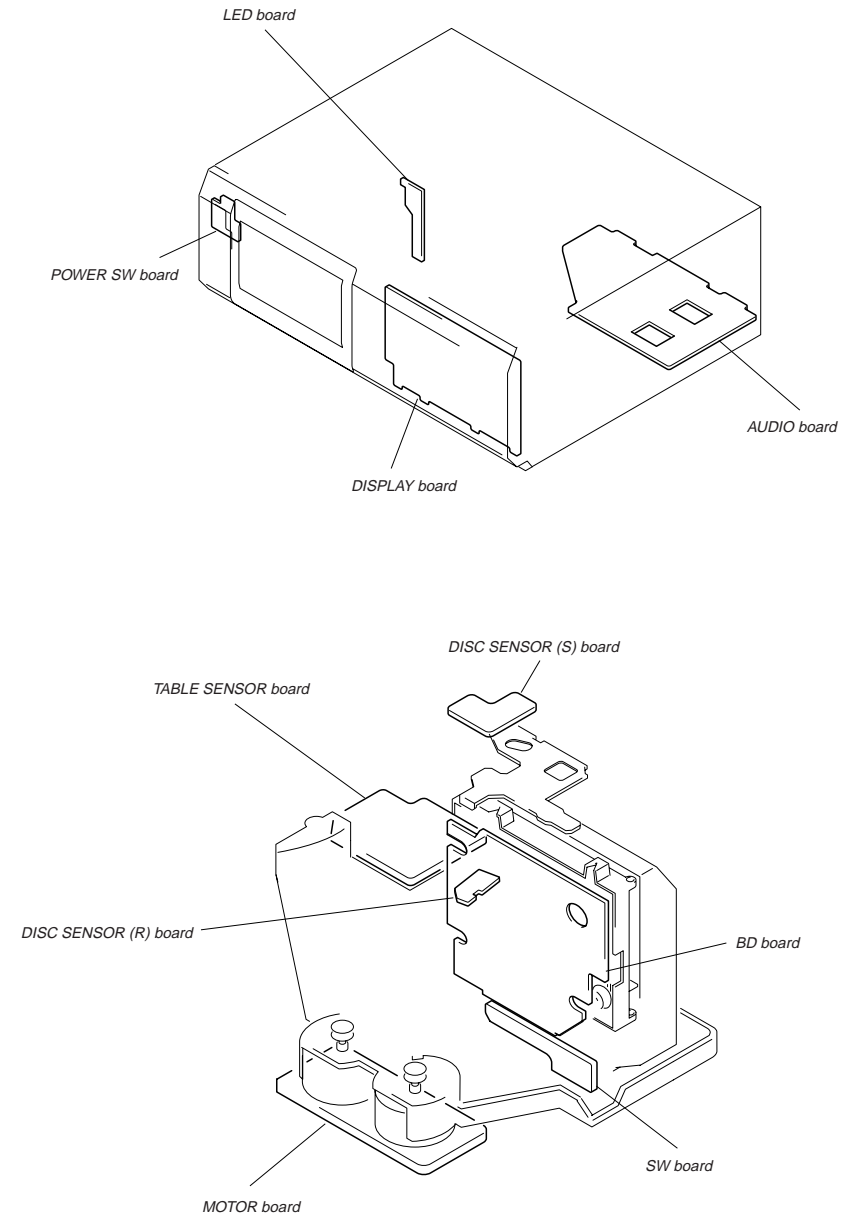

#### When a general remote commander is not used:

- Solder lead wires to TP (DVDD) and TP (TOFF) on the BD board severally.
- Connect the oscilloscope to TP (TE) of the BD board.
- Press the [POWER] button and turn ON the power supply.
- Open the front cover, and press the [PLUS ONE] button.
- Set the disc (YEDS-18) into the "PLUS ONE" slit.
- Close the front cover, and chuck the disc.
- Playback the fifth track of the disc.
- Short-circuit the lead wire connected at step 1. (The tracking servo is turned OFF)
- Check the level B of the oscilloscope's waveform and the A (DC voltage) of the center of the Traverse waveform.  
Confirm the following:  
 $A/B \times 100 = \text{less than } \pm 10\%$

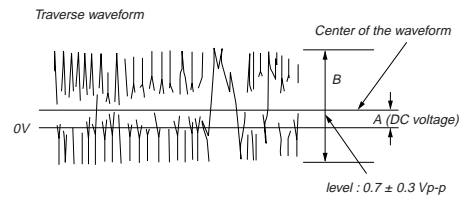

- Disconnect the lead wire short-circuited at step 8. (The tracking servo is turned ON.) Confirm the C (DC voltage) is almost equal to the A (DC voltage) is step 8.

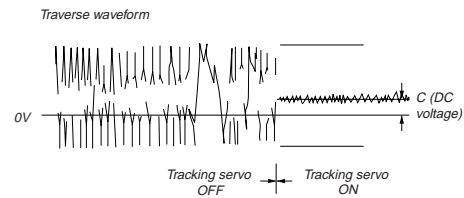

- Turn OFF the power, and remove the lead wire connected at step 1.

#### RF PLL Free-run Frequency Check

##### Procedure :

- Connect the frequency counter to TP (PLCK) of the BD board.

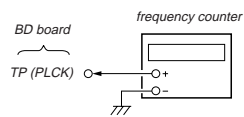

- Press the [POWER] button and turn ON the power supply.
- Open the front cover, and press the [PLUS ONE] button.
- Set the disc (YEDS-18) into the "PLUS ONE" slit.
- Close the front cover, and chuck the disc.
- Playback the fifth track of the disc.
- Confirm that reading on frequency counter is  $4.3218 \text{ MHz} \pm 30 \text{ kHz}$ .

#### About RV502 on the AUDIO board

RV502 of the AUDIO board requires no adjustments. Please note that it should be dixed to mechanical center position when you moved and do not know origin position.

#### Adjustment Location :

##### [ BD BOARD ] — CONDUCTOR SIDE —

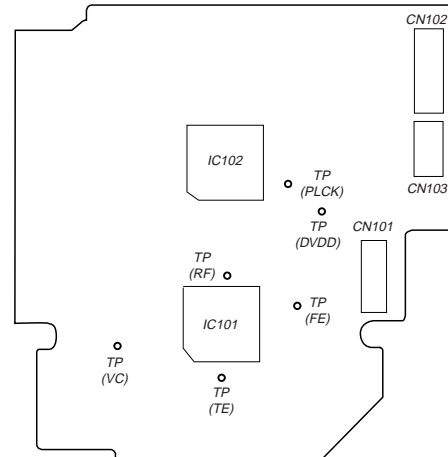

##### [ DISPLAY BOARD ] — CONDUCTOR SIDE —

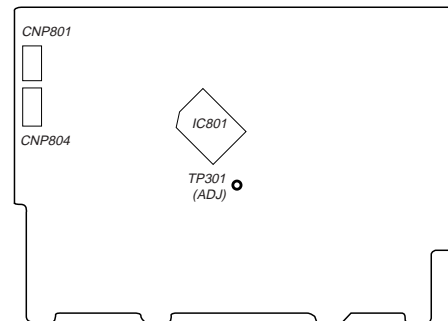

##### [ AUDIO BOARD ] — COMPONENT SIDE —

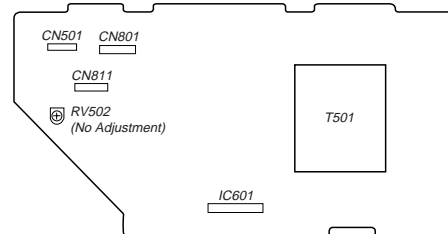

7-2. PRINTED WIRING BOARD — BD SECTION —

• See page 20 for Circuit Boards Location.

• Semiconductor Location

Ref. No.	Location
IC101	E-3
IC102	C-3
IC103	C-1
Q101	C-5
Q102	C-5
Q103	F-2

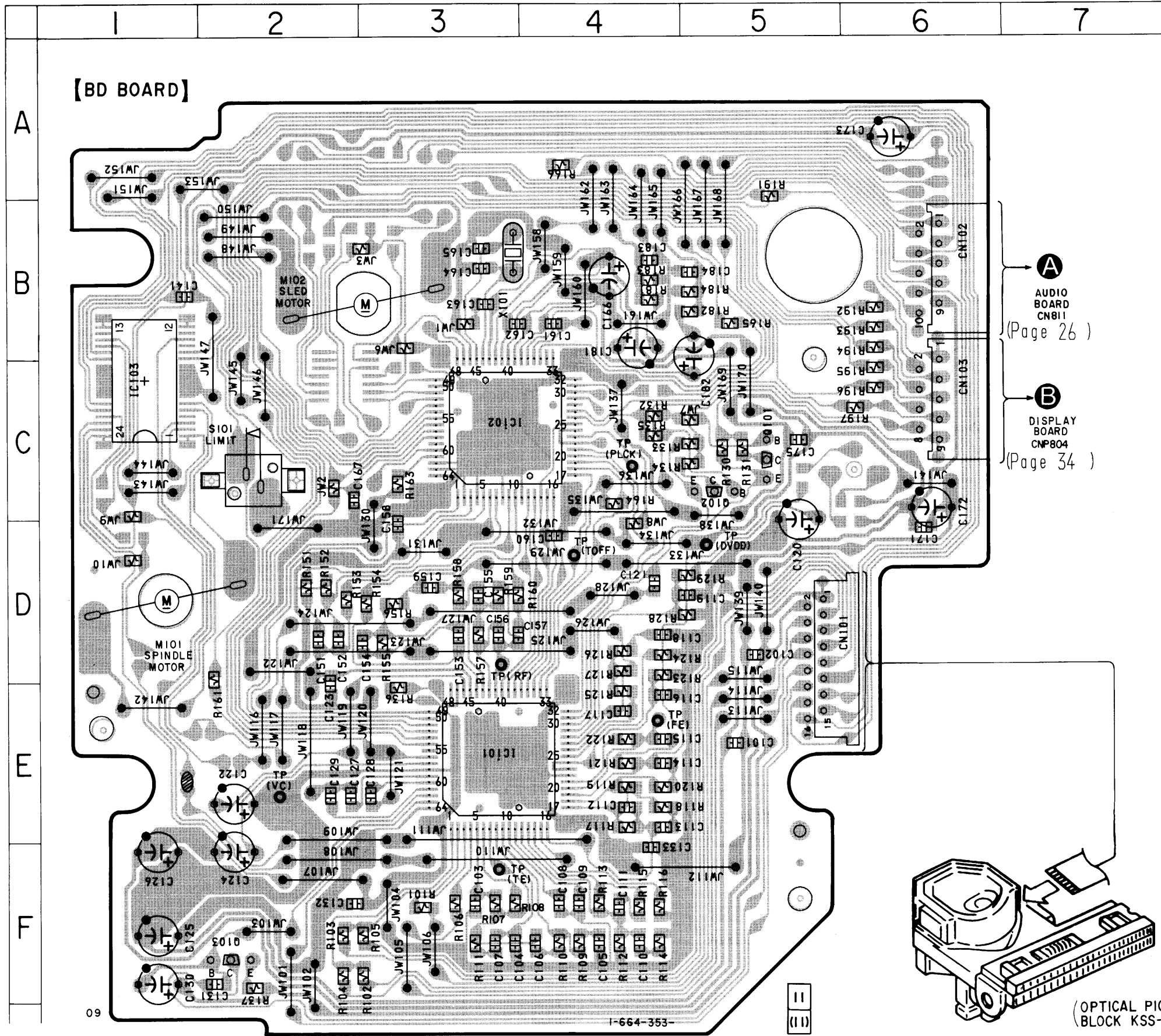

7-3. SCHEMATIC DIAGRAM — BD SECTION —

- See page 38 for IC Pin Functions.
- See page 44 for IC Block Diagrams.

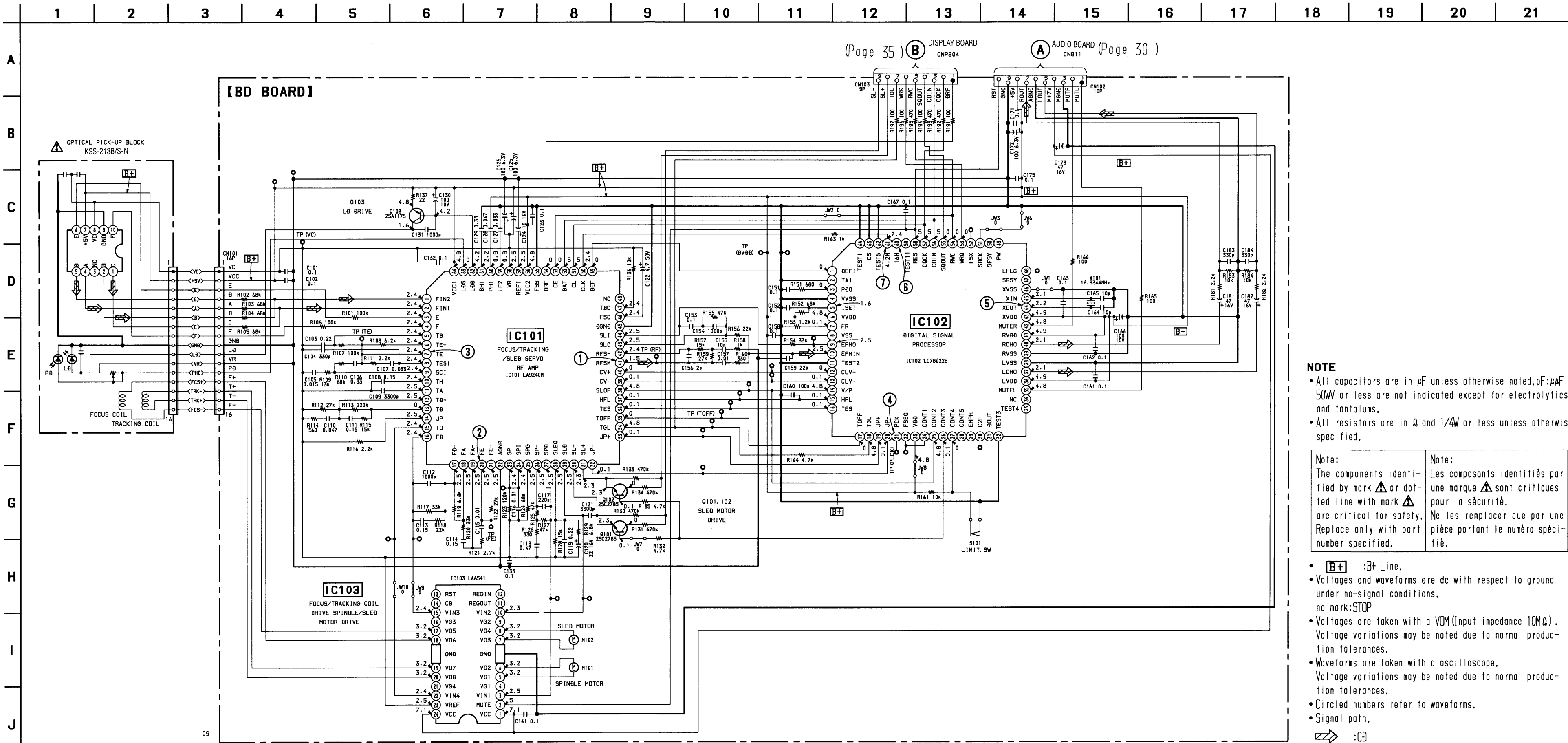

• Waveforms

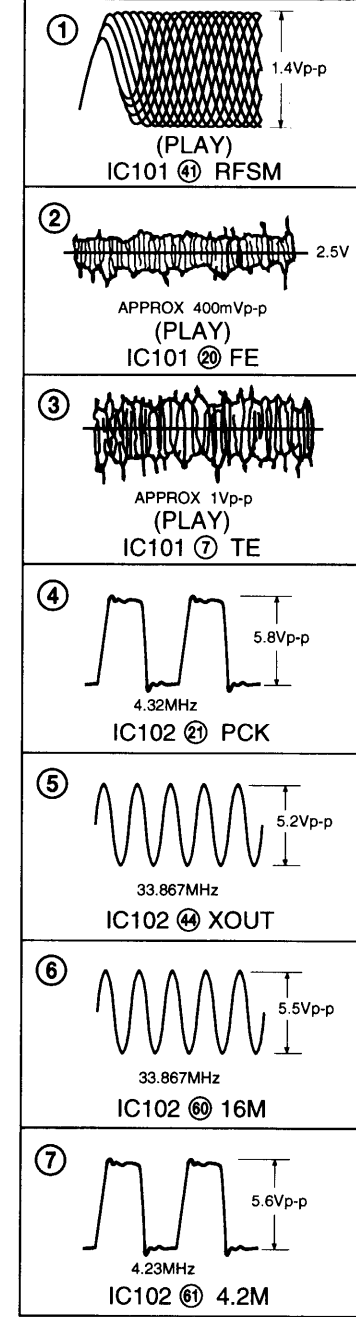

**NOTE**

- All capacitors are in  $\mu\text{F}$  unless otherwise noted, pF:  $\mu\text{pF}$ . 50W or less are not indicated except for electrolytics and tantalums.
- All resistors are in  $\Omega$  and  $1/4\text{W}$  or less unless otherwise specified.

Note:  
The components identified by mark  $\Delta$  or dotted line with mark  $\Delta$  are critical for safety. Replace only with part number specified.

Note:  
Les composants identifiés par une marque  $\Delta$  sont critiques pour la sécurité. Ne les remplacer que par une pièce portant le numéro spécifié.

- **B+** :B+ Line.
  - Voltages and waveforms are dc with respect to ground under no-signal conditions. no mark:STOP
  - Voltages are taken with a VOM (Input impedance 10M $\Omega$ ). Voltage variations may be noted due to normal production tolerances.
  - Waveforms are taken with an oscilloscope. Voltage variations may be noted due to normal production tolerances.
  - Circled numbers refer to waveforms.
  - Signal path.
- $\Rightarrow$  :CD



7-4. PRINTED WIRING BOARD — MAIN SECTION —

• See page 20 for Circuit Boards Location.

• Semiconductor Location

Ref. No.	Location
D51	G-4
D301	F-8
D701	D-11
D702	D-11
D703	C-11
D704	C-11
D705	D-11
D706	E-11
D707	D-11
D708	D-10
D709	D-10
D710	E-11
D841	B-17
D842	B-17
D843	A-17
IC51	E-3
IC52	E-2
IC53	E-1
IC501	E-9
IC502	E-10
IC601	B-10
IC701	D-9
IC702	B-9
Q51	G-1
Q301	F-9
Q302	F-11
Q303	E-7
Q313	F-9
Q401	F-10
Q402	F-11
Q403	E-7
Q413	F-10
Q501	F-11
Q701	E-12
Q702	E-11

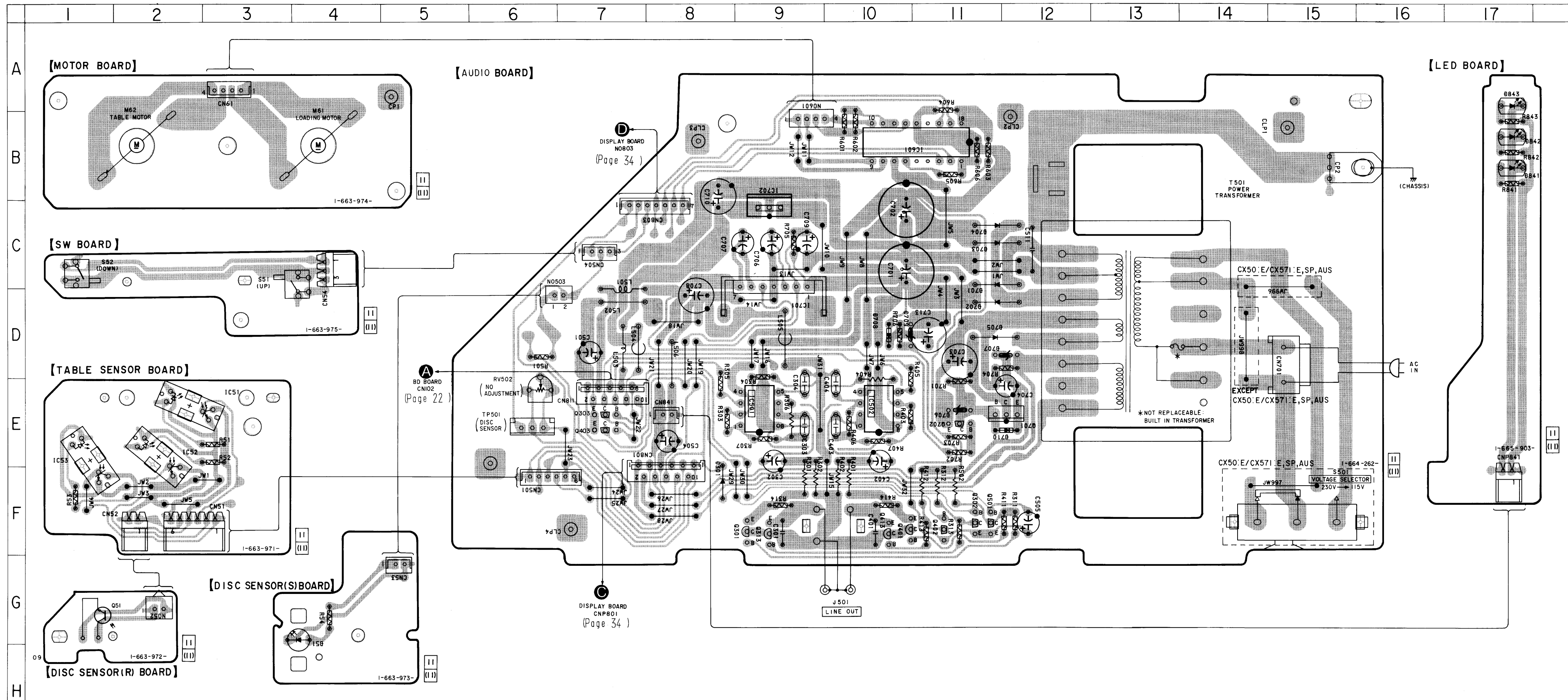

Note:  
 • : parts extracted from the component side.  
 • : Pattern from the side which enable seeing.

7-5. SCHEMATIC DIAGRAM — MAIN SECTION —  
 • See page 44 for IC Block Diagrams.

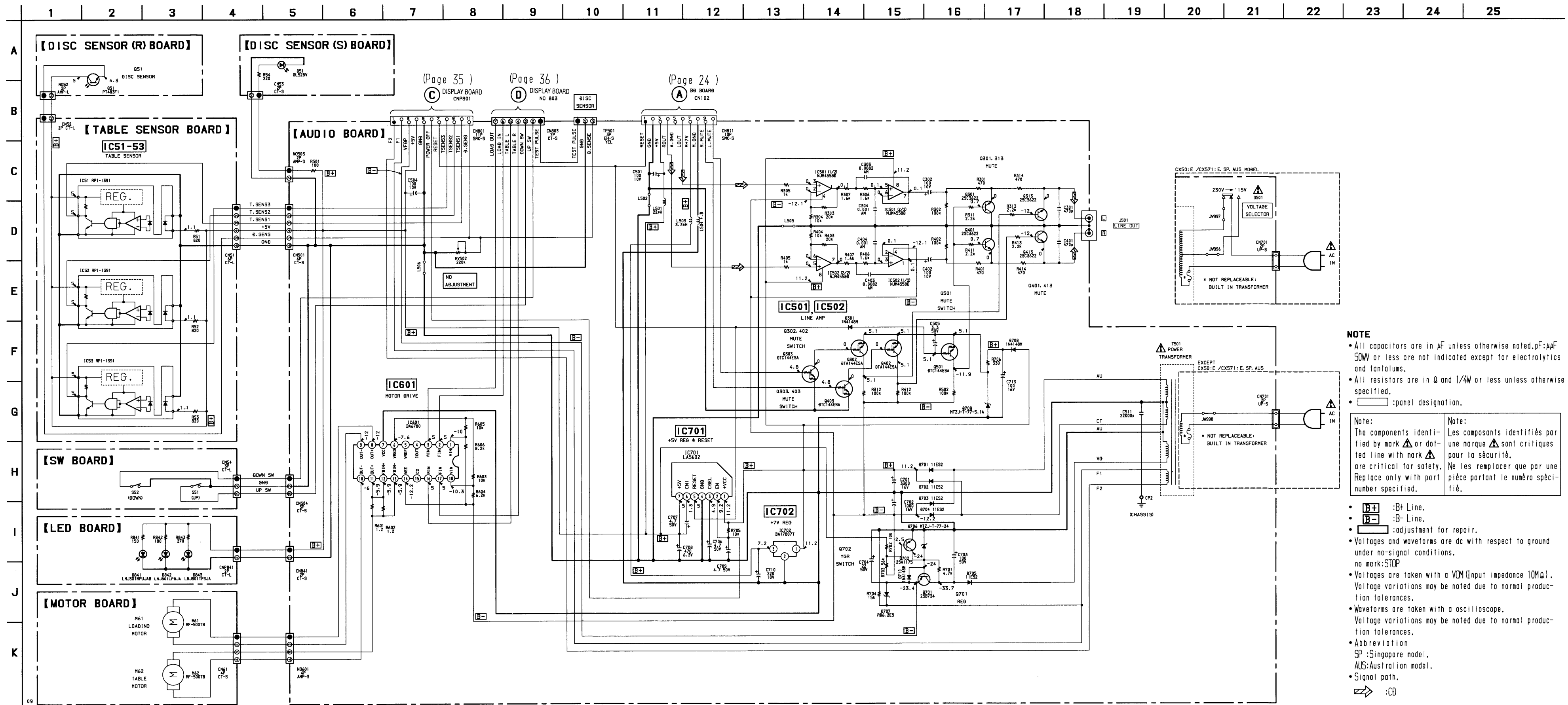

**NOTE**

- All capacitors are in  $\mu\text{F}$  unless otherwise noted, pF:  $\mu\text{pF}$  50W or less are not indicated except for electrolytics and tantalums.
- All resistors are in  $\Omega$  and  $1/4\text{W}$  or less unless otherwise specified.
- : panel designation.

<p>Note: The components identified by mark <math>\Delta</math> or dotted line with mark <math>\Delta</math> are critical for safety. Replace only with part number specified.</p>	<p>Note: Les composants identifiés par une marque <math>\Delta</math> sont critiques pour la sécurité. Ne les remplacer que par une pièce portant le numéro spécifié.</p>
---	---

- B+ :B+ Line.
- B- :B- Line.
- : adjustment for repair.
- Voltages and waveforms are dc with respect to ground under no-signal conditions. no mark: STOP
- Voltages are taken with a VOM (input impedance 10M $\Omega$ ). Voltage variations may be noted due to normal production tolerances.
- Waveforms are taken with an oscilloscope. Voltage variations may be noted due to normal production tolerances.
- Abbreviation  
SP :Singapore model.  
AUS: Australian model.
- Signal path.
- $\Rightarrow$  :CO

7-6. PRINTED WIRING BOARD — PANEL SECTION —  
 • See page 20 for Circuit Boards Location.

• Semiconductor Location

Ref. No.	Location
D801	C-4
D802	C-6
D803	C-2
IC801	E-6
IC802	G-10
Q801	F-10
Q811	D-5

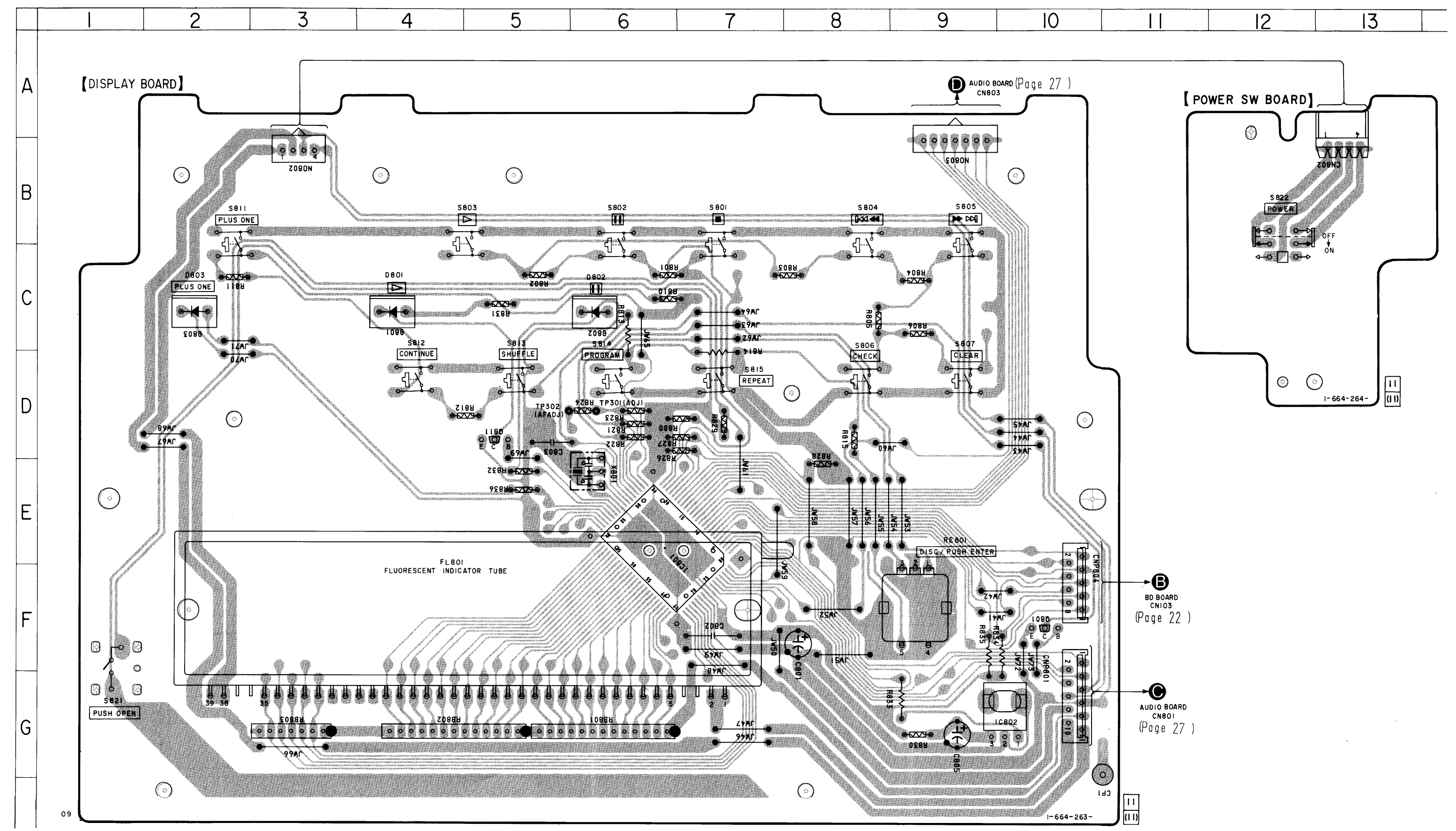

**Note:**

- : parts extracted from the component side.
- △ : internal component.
- : Pattern from the side which enable seeing.



7-7. SCHEMATIC DIAGRAM — PANEL SECTION —  
 • See page 42 for IC Pin Functions.

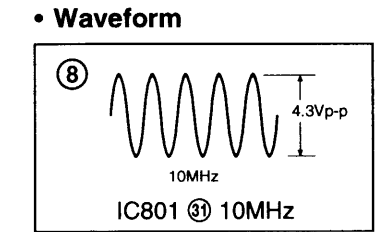
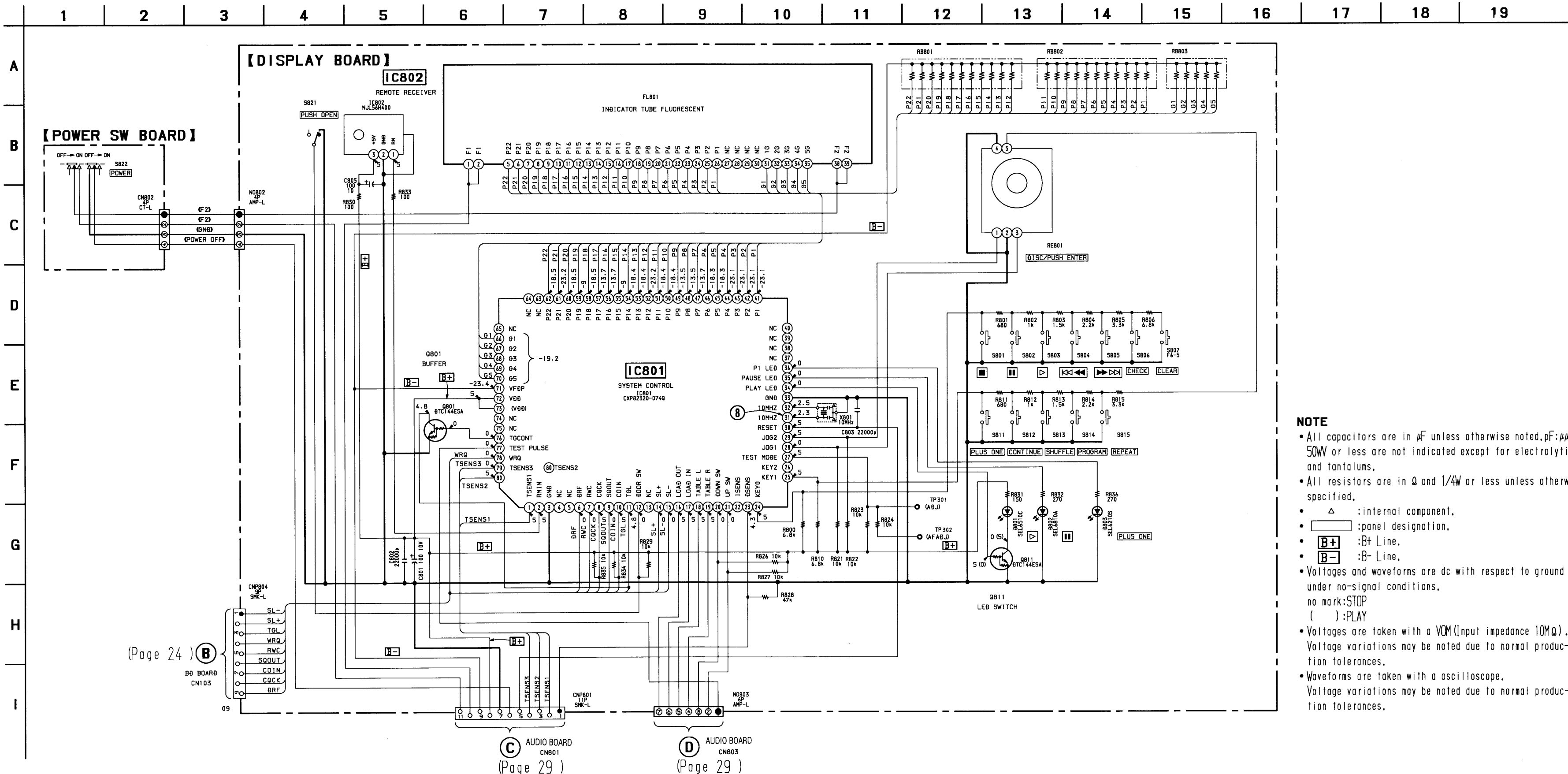

**NOTE**

- All capacitors are in  $\mu\text{F}$  unless otherwise noted.  $\text{pF}:\mu\text{F}$  50W or less are not indicated except for electrolytics and tantalums.
- All resistors are in  $\Omega$  and  $1/4\text{W}$  or less unless otherwise specified.
- $\Delta$  : internal component.
- $\square$  : panel designation.
- $\text{B}+$  : B+ Line.
- $\text{B}-$  : B- Line.
- Voltages and waveforms are dc with respect to ground under no-signal conditions.  
 no mark: STOP  
 ( ) : PLAY
- Voltages are taken with a VOM (Input impedance  $10\text{M}\Omega$ ). Voltage variations may be noted due to normal production tolerances.
- Waveforms are taken with an oscilloscope. Voltage variations may be noted due to normal production tolerances.

(Page 24)

**B**

B0 BOARD  
CN105

**C** AUDIO BOARD  
CN801  
(Page 29)

**D** AUDIO BOARD  
CN803  
(Page 29)

## 7-8. IC PIN FUNCTIONS

### • IC101 FOCUS/TRACKING/SLED SERVO (LA9240M)

Pin No.	Pin Name	I/O	Function
1	FIN2	I	Connected to the pick-up photodiode Added with FIN1 to create RF signal, subtracted with FIN1 to create FE signal
2	FIN1	I	Connected to the pick-up photodiode
3	E	I	Connected to the pick-up photodiode Subtracted with F to create TE signal
4	F	I	Connected to the pick-up photodiode
5	TB	I	DC component of the TE signal is input
6	TE-	I	Connects the TE signal gain setting resistor between TE pins
7	TE	O	TE signal output
8	TESI	I	TES (Track Error Sense) comparator input. The TE signal is band-passed and input
9	SCI	I	Shock detection input
10	TH	I	Tracking gain time constant setting
11	TA	O	TA amplifier output
12	TD-	I	Creates a tracking phase compensation constant between TD and VR pins
13	TD	O	Tracking phase compensation setting
14	JP	I	Tracking jump signal (kick pulse) amplitude setting
15	TO	O	Tracking control signal output
16	FD	O	Focusing control signal output
17	FD-	I	Creates a focusing phase compensation constant between FD and FA pins
18	FA	O	Creates a focusing phase compensation constant between FD- and FA- pins
19	FA-	I	Creates a focusing phase compensation constant between FA and FE pins
20	FE	O	FE signal output
21	FE-	I	Connects the FE signal gain setting resistor between TE pins
22	AGND	-	Analog signal Ground
23	SP	O	Single end output of CV+ and CV- pin signal
24	SPI	I	Spindle amplifier input
25	SPG	I	Gain setting resistor is connected when the spindle 12cm mode
26	SP-	I	Works together with the SPD pin to connect to the spindle phase compensation constant
27	SPD	O	Spindle control signal output
28	SLEQ	I	Sled phase compensation constant is connected
29	SLD	O	Sled control signal output
30	SL-	I	Sled feeding signal is input from the microprocessor
31	SL+	I	Sled feeding signal is input from the microprocessor
32	JP-	I	Tracking jump signal is input from the DSP
33	JP+	I	Tracking jump signal is input from the DSP
34	TGL	I	Tracking gain control signal is input from the DSP Gain becomes low when TGL is "H"
35	TOFF	I	Tracking off control signal is input from the DSP Tracking becomes off when TOFF is "H"
36	TES	O	Outputs TES signal to the DSP
37	HFL	O	HFL (High Frequency Level) is used to determine whether the main beam is positioned on a pit or a mirror

Pin No.	Pin Name	I/O	Function
38	SLOF	I	Sled servo off control input
39	CV-	I	CLV error signal is input from the digital signal processor
40	CV+	I	CLV error signal is input from the digital signal processor
41	RFSM	O	RF output
42	RFS-	I	Works together with the RFSM pin to set the RF gain and the 3T compensation constant for the EFM signal
43	SLC	O	SLI (Slice Level Control) is output to control a data slice level of the RF waveform by the digital signal processor
44	SLI	I	Input pin for controlling a data slice level by the digital signal processor
45	DGND	-	Digital Ground
46	FSC	O	Focus search smoothing capacitor output
47	TBC	I	TBC (Tracking Balance Control) sets a EF balance variable range
48	NC	-	Not used
49	DEF	O	Defect detection output for a disc
50	CLK	I	Reference clock input The 4.23 MHz of the digital signal processor is input
51	CL	I	Microprocessor command clock input
52	DAT	I	Microprocessor command data input
53	CE	I	Microprocessor command chip enable input
54	DRF	O	DRF (Defect RF) outputs a RF level detection
55	FSS	I	FSS (Focus Search Select) is a switching pin for the focus search mode ( $\pm$ search/+search for a reference voltage)
56	VCC2	-	Servo system and digital system VCC
57	RFFI	I	Reference voltage bus control is connected
58	VR	O	Reference voltage output
59	LF2	I	Constant setting for a disc defect detection
60	PH1	I	Connected to the capacitor for the RF signal peak hold
61	BH1	I	Connected to the capacitor for the RF signal bottom hold
62	LDD	O	APC circuit output
63	LDS	I	APC circuit input
64	VCC1	-	RF system VCC

- Abbreviation  
EFM : Eight to Fourteen Modulation  
APC : Auto Power Control

#### • IC102 DIGITAL SIGNAL PROCESSOR (LC78622E)

Pin No.	Pin Name	I/O	Function
1	DEFI	I	Defect detection signal (DEF) input (Be sure to connect to 0 when not in use)
2	TAI	I	PLL Test input Incorporates a pull-down resistor Be sure to connect to 0V
3	PDO	O	PLL Phase comparison output for external VCO control
4	VVSS	-	PLL Ground for the built-in VCO Be sure to connect to 0 when not in use
5	ISET	I	Connected to a current adjusting resistor for the PDO output
6	VVDD	-	Built-in VCO power supply
7	FR	I	Adjusts the VCO frequency range
8	VSS	-	Digital Ground Be sure to connect to 0
9	EFMO	O	Slice level control EFM signal output
10	EFMIN	I	Slice level control EFM signal input
11	TEST2	I	Test input Incorporates a pull-down resistor Be sure to connect to 0V
12	CLV+	O	Disc motor control output 3-value output available depending on the command
13	CLV-	O	
14	$\overline{V/P}$	O	Rough servo/phase control automatic switching monitor output "H":rough servo, "L":phase servo
15	HFL	I	Tracking detection signal input Schmidt input
16	TES	I	Tracking error signal input Schmidt input
17	TOFF	O	Tracking OFF output
18	TGL	O	Tracking gain switching output Raises gain when "L"
19	JP+	O	Track jump control output 3-value output available depending on the command
20	JP-	O	
21	PCK	O	EFM data playback clock monitor 4.3218 MHz when phase is locked
22	FSEQ	O	Sync signal detection output "H" when a sync signal detected from the EFM signal and that generated internally coincide
23	VDD	-	Digital power supply
24	CONT1	I/O	General purpose output 1 Performs control using a serial data command from the microprocessor When not in use, connect to 0V by setting to an input or set to an open state by setting to an output
25	CONT2	I/O	General purpose output 2 Performs control using a serial data command from the microprocessor When not in use, connect to 0V by setting to an input or set to an open state by setting to an output
26	CONT3	I/O	General purpose output 3 Performs control using a serial data command from the microprocessor When not in use, connect to 0V by setting to an input or set to an open state by setting to an output
27	CONT4	I/O	General purpose output 4 Performs control using a serial data command from the microprocessor When not in use, connect to 0V by setting to an input or set to an open state by setting to an output
28	CONT5	I/O	General purpose output 5 Performs control using a serial data command from the microprocessor When not in use, connect to 0V by setting to an input or set to an open state by setting to an output

- Abbreviation  
PLL : Phase Locked Loop  
EFM : Eight to Fourteen Modulation

Pin No.	Pin Name	I/O	Function
29	EMPH	O	Deemphasis monitor The deemphasis disc is being played back when “H”
30	C2F	O	C2 flag output
31	DOUT	O	Digital OUT output (EIAJ format)
32	TEST3	I	Test input Incorporates a pull-down resistor Be sure to connect to 0V
33	TEST4	I	Test input Incorporates a pull-down resistor Be sure to connect to 0V
34	N. C.	–	Not used Be sure to use it in an open state
35	MUTEL	O	L channel 1-bit DAC L channel mute output
36	LVDD	–	L channel 1-bit DAC L channel power supply
37	LCHO	O	L channel 1-bit DAC L channel output
38	LVSS	–	L channel 1-bit DAC L channel ground Be sure to connect to 0V
39	RVSS	–	R channel 1-bit DAC R channel ground Be sure to connect to 0V
40	RCHO	O	R channel 1-bit DAC R channel output
41	RVDD	–	R channel 1-bit DAC R channel power supply
42	MUTER	O	R channel 1-bit DAC R channel mute output
43	XVDD	–	Power supply for the crystal oscillator
44	XOUT	O	Connected to the 16.9344 MHz crystal oscillator
45	XIN	I	
46	XVSS	–	Ground for the crystal oscillator Be sure to connect to 0V
47	SBSY	O	Sync signal output for the subcode block
48	EFLG	O	C1, C2, single correction, and double correction monitor
49	PW	O	Subcode P, Q, R, S, T, U, W output
50	SFSY	O	Subcode frame sync signal output Rises when the subcode is in a standby
51	SBCK	I	Subcode read clock input Schmidt input (Connect to 0V when not in use)
52	FSX	O	7.35 kHz sync signal output divided from the crystal oscillation
53	WRQ	O	Subcode Q output standby output
54	RWC	I	Read/write control input Schmidt input
55	SQOUT	O	Subcode Q output
56	COIN	I	Command input from the microprocessor
57	$\overline{\text{CQCK}}$	I	Command input fetching clock input or subcode extracting clock input from SQOUT Schmidt input
58	$\overline{\text{RES}}$	I	LC78622 reset input Temporarily set to “L” when the power is turned ON
59	TST11	O	Test output Use it in an open state (Normally, “L” output)
60	16M	O	16.9344 MHz output
61	4.2M	O	4.2336 MHz output
62	TEST5	I	Test input. Incorporates a pull-down resistor. Be sure to connect to 0V
63	$\overline{\text{CS}}$	I	Chip select input Incorporates a pull-down resistor Be sure to connect to 0V when not in control
64	TEST1	I	Test input Does not incorporate a pull-down resistor Be sure to connect to 0V

**Note)** Supply the same potential to each power supply pin (VDD, VVDD, LVDD, RVDD, XVDD).

• IC801 SYSTEM CONTROL (CXP82320-074Q)

Pin No.	Pin Name	I/O	Function
1	TSENS1	I	Table sensor input
2	RMIN	I	SIRCS input
3	GND	–	Ground
4	NC	O	Not used
5	NC	O	Not used
6	DRF	I	DRF (FOK) input
7	RWC	O	RWC (Latch) output
8	CQCK	O	Command output/Clock output for sub code
9	SQOUT	I	Sub code reading data input
10	COIN	O	Command data output
11	TGL	I	TGL input
12	DOOR SW	I	DOOR SW input
13	NC	O	Not used
14	SL+	O	Sled motor (External circuit direction) output
15	SL–	O	Sled motor (Internal circuit direction) output
16	LOAD OUT	O	Loading motor (Out a direction) output PWM output
17	LOAD IN	O	Loading motor (In a direction) output PWM output
18	TABLE L	O	Table rotation (Left a direction) output PWM output
19	TABLE R	O	Table rotation (Right a direction) output PWM output
20	DOWN SW	I	Loading out SW input
21	UP SW	I	Loading in SW input
22	ISENS	O	Not used
23	DSSENS	I	Disc sensor analog input
24	KEY0	I	Operation key (0) analog input
25	KEY1	I	Operation key (1) analog input
26	KEY2	O	Not used
27	TEST MODE	I	Test mode analog input
28	JOG1	I	Jog dial phase input (1)
29	JOG2	I	Jog dial phase input (2)
30	RESET	I	Micon reset input
31	10MHz	–	Ceramic oscillator pin
32	10MHz	–	Ceramic oscillator pin
33	GND	–	Ground
34	PLAY LED	O	PLAY LED Output (H: ON)
35	PAUSE LED	O	PAUSE LED Output (H: ON)
36	PLUS 1 LED	O	PLUS ONE LED Output (H: ON)
37	NC	O	Not used
38	NC	O	Not used
39	NC	O	Not used
40	NC	O	Not used

• Abbreviation

TGL : Tracking Gain (Low)

PWM : Pulse Width Modulation

Pin No.	Pin Name	I/O	Function
41	P1	O	Fluorescent indicator tube segment output
42	P2	O	Fluorescent indicator tube segment output
43	P3	O	Fluorescent indicator tube segment output
44	P4	O	Fluorescent indicator tube segment output
45	P5	O	Fluorescent indicator tube segment output
46	P6	O	Fluorescent indicator tube segment output
47	P7	O	Fluorescent indicator tube segment output
48	P8	O	Fluorescent indicator tube segment output
49	P9	O	Fluorescent indicator tube segment output
50	P10	O	Fluorescent indicator tube segment output
51	P11	O	Fluorescent indicator tube segment output
52	P12	O	Fluorescent indicator tube segment output
53	P13	O	Fluorescent indicator tube segment output
54	P14	O	Fluorescent indicator tube segment output
55	P15	O	Fluorescent indicator tube segment output
56	P16	O	Fluorescent indicator tube segment output
57	P17	O	Fluorescent indicator tube segment output
58	P18	O	Fluorescent indicator tube segment output
59	P19	O	Fluorescent indicator tube segment output
60	P20	O	Fluorescent indicator tube segment output
61	P21	O	Fluorescent indicator tube segment output
62	P22	O	Fluorescent indicator tube segment output
63	NC	O	Not used
64	NC	O	Not used
65	NC	O	Not used
66	G1	O	Fluorescent indicator tube grid output
67	G2	O	Fluorescent indicator tube grid output
68	G3	O	Fluorescent indicator tube grid output
69	G4	O	Fluorescent indicator tube grid output
70	G5	O	Fluorescent indicator tube grid output
71	VFDP	I	Reference voltage input for fluorescent indicator tube
72	VDD	–	+5V power supply
73	(VDD)	–	+5V power supply
74	NC	O	Not used
75	NC	O	Not used
76	TGC	O	TGL external control output
77	TEST PULSE	O	Table position detection pulse output
78	WRQ	I	Sub-code synchronizing signal input
79	TSENS3	I	Table sensor (3) input
80	TSENS2	I	Table sensor (2) input

## 7-9. IC BLOCK DIAGRAMS

### IC101 LA9240M

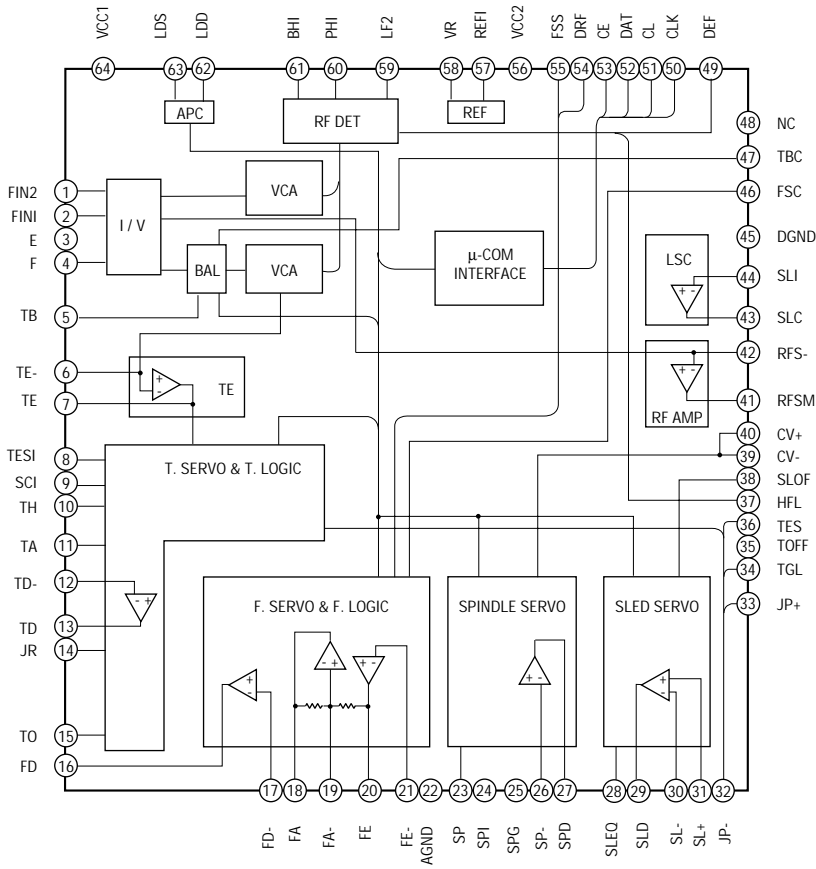

### IC102 LC78622E

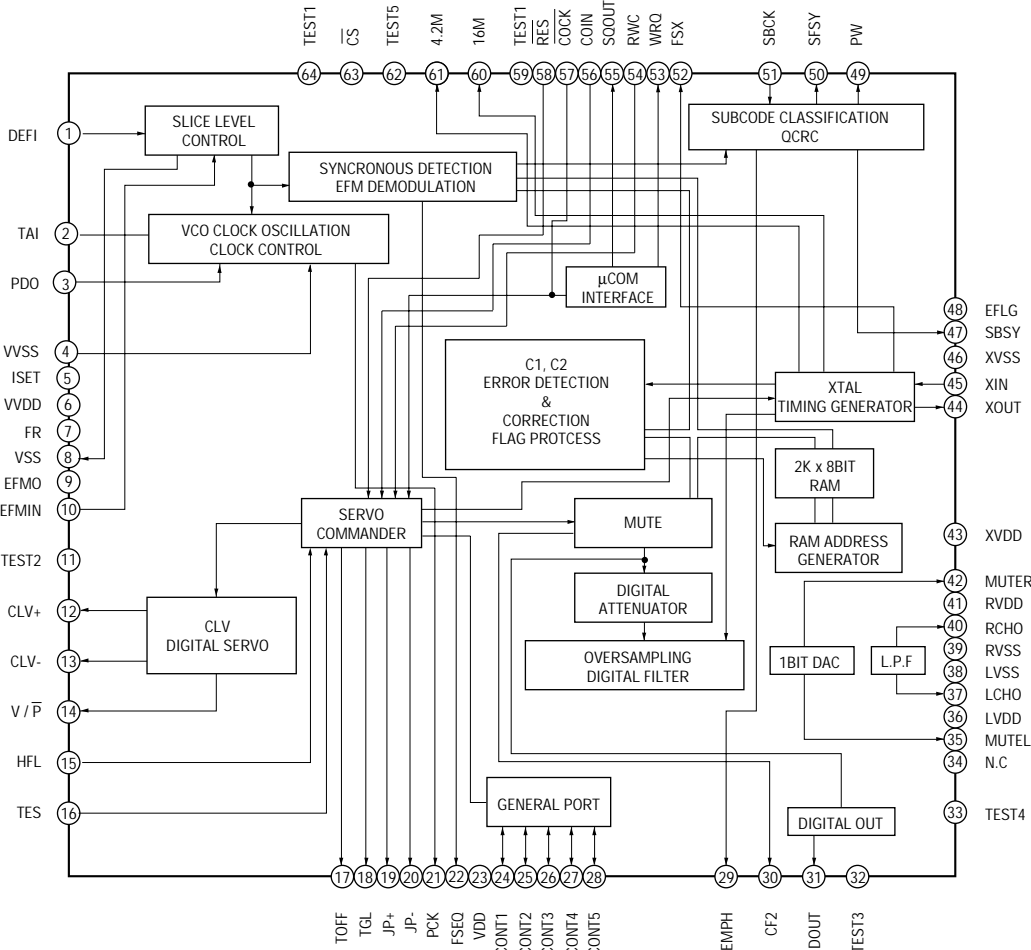

**IC103 LA6541**

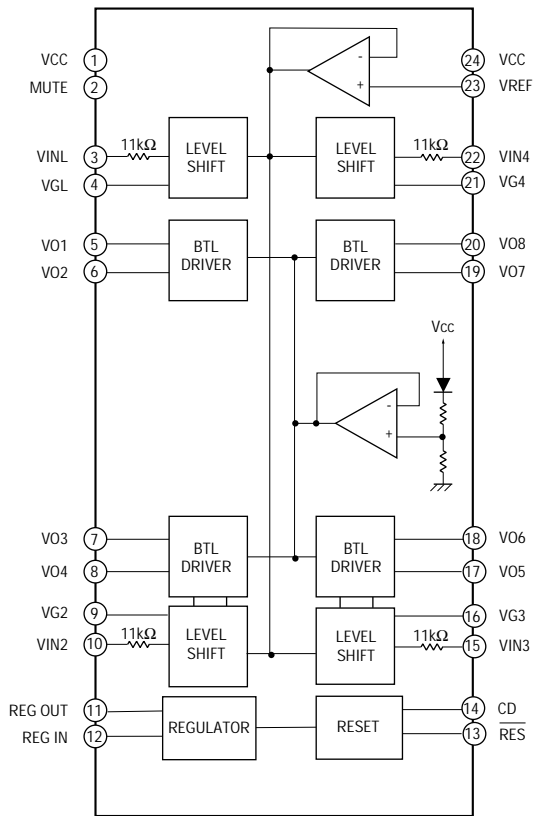

**IC701 LA5602**

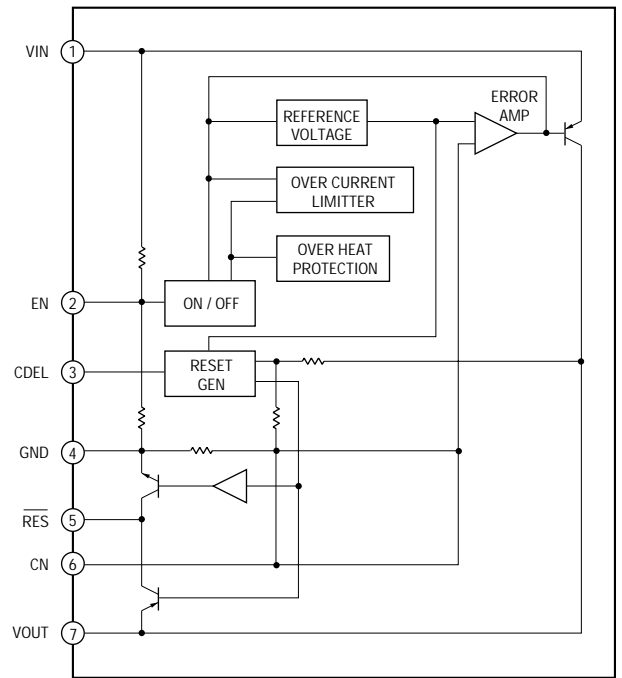

**IC601 BA6780**

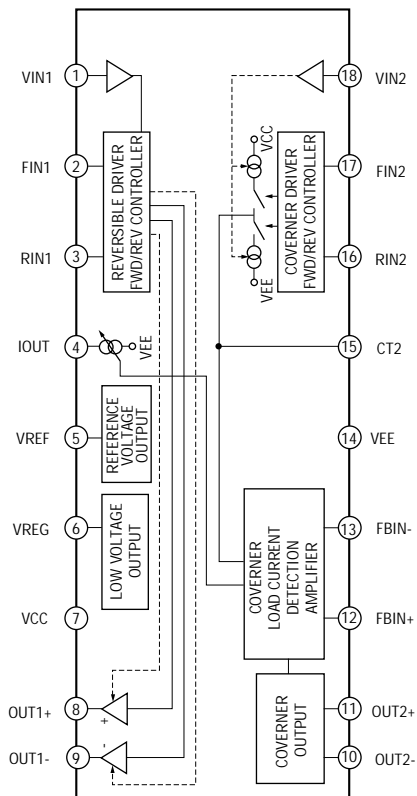



## SECTION 8 EXPLODED VIEWS

**NOTE:**

- Items marked “\*” are not stocked since they are seldom required for routine service. Some delay should be anticipated when ordering these items.
- The mechanical parts with no reference number in the exploded views are not supplied.
- Hardware (# mark) list and accessories and packing materials are given in the last of this parts list.

- Abbreviation  
 CND : Canadian model  
 G : German model  
 SP : Singapore model  
 AUS : Australian model

The components identified by mark  $\triangle$  or dotted line with mark  $\triangle$  are critical for safety. Replace only with part number specified.

Les composants identifiés par une marque  $\triangle$  sont critiques pour la sécurité.

Ne les remplacer que par une pièce portant le numéro spécifié.

### 8-1. CASE SECTION

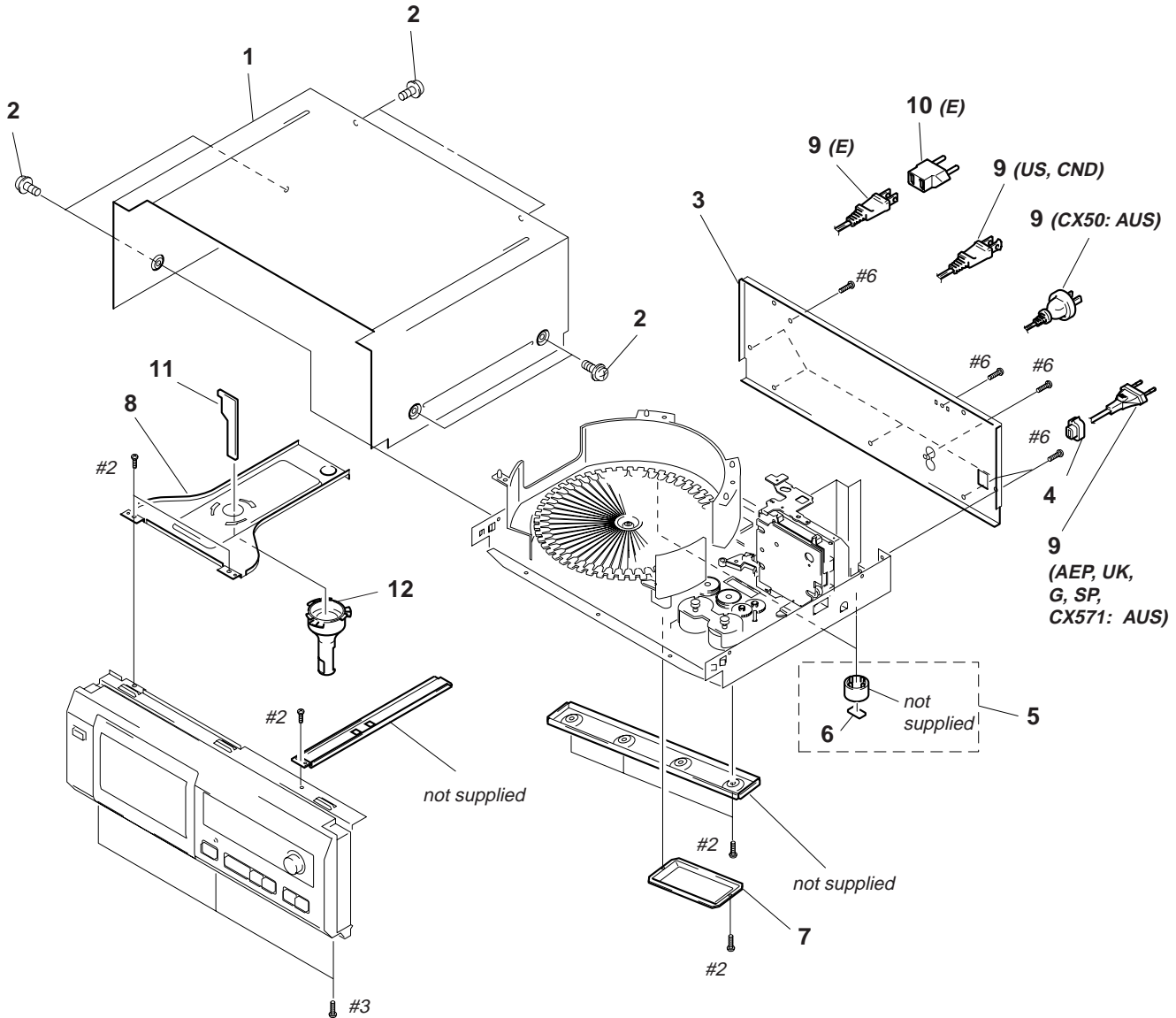

Ref. No.	Part No.	Description	Remark	Ref. No.	Part No.	Description	Remark
* 1	4-987-999-11	CASE		* 4	3-703-571-11	BUSHING (S) (4516), CORD (E)	
2	3-704-366-01	SCREW (CASE) (M3X8)		5	X-3371-435-1	FOOT (SMALL) ASSY	
* 3	4-987-981-01	PANEL, BACK (CX50:US)		* 6	4-978-398-21	CUSHION	
* 3	4-987-981-11	PANEL, BACK (CX50:CND)		* 7	4-988-534-01	COVER, MOTOR	
* 3	4-987-981-21	PANEL, BACK (CX50:AEP,G)		8	4-991-165-01	BRACKET (ILLUMINATION)	
* 3	4-987-981-31	PANEL, BACK (CX50:AUS)		$\triangle$ 9	1-558-943-61	CORD, POWER (E)	
* 3	4-987-981-41	PANEL, BACK (CX50:E)		$\triangle$ 9	1-575-651-21	CORD, POWER	
* 3	4-987-981-51	PANEL, BACK (CX50:SP)				(CX50:AEP,G,SP/CX571:AEP,G,SP,AUS)	
* 3	4-989-203-01	PANEL, BACK (CX571:US)		$\triangle$ 9	1-590-926-11	CORD, POWER (US,CND)	
* 3	4-989-203-11	PANEL, BACK (CX571:CND)		$\triangle$ 9	1-696-845-11	CORD, POWER (CX50:AUS)	
* 3	4-989-203-21	PANEL, BACK (CX571:E)		$\triangle$ 9	1-769-639-11	CORD, POWER (CX571:UK)	
* 3	4-989-203-31	PANEL, BACK (CX571:SP,AUS)		$\triangle$ 10	1-569-007-11	ADAPTOR, CONVERSION 2P (CX50:E)	
* 3	4-989-203-41	PANEL, BACK (CX571:AEP,G)		* 11	1-665-903-11	LED BOARD	
* 3	4-989-203-51	PANEL, BACK (CX571:UK)		12	X-4948-515-1	ILLUMINATION ASSY	
* 4	3-703-244-00	BUSHING (2104), CORD (EXCEPT E)					

## 8-2. FRONT PANEL SECTION

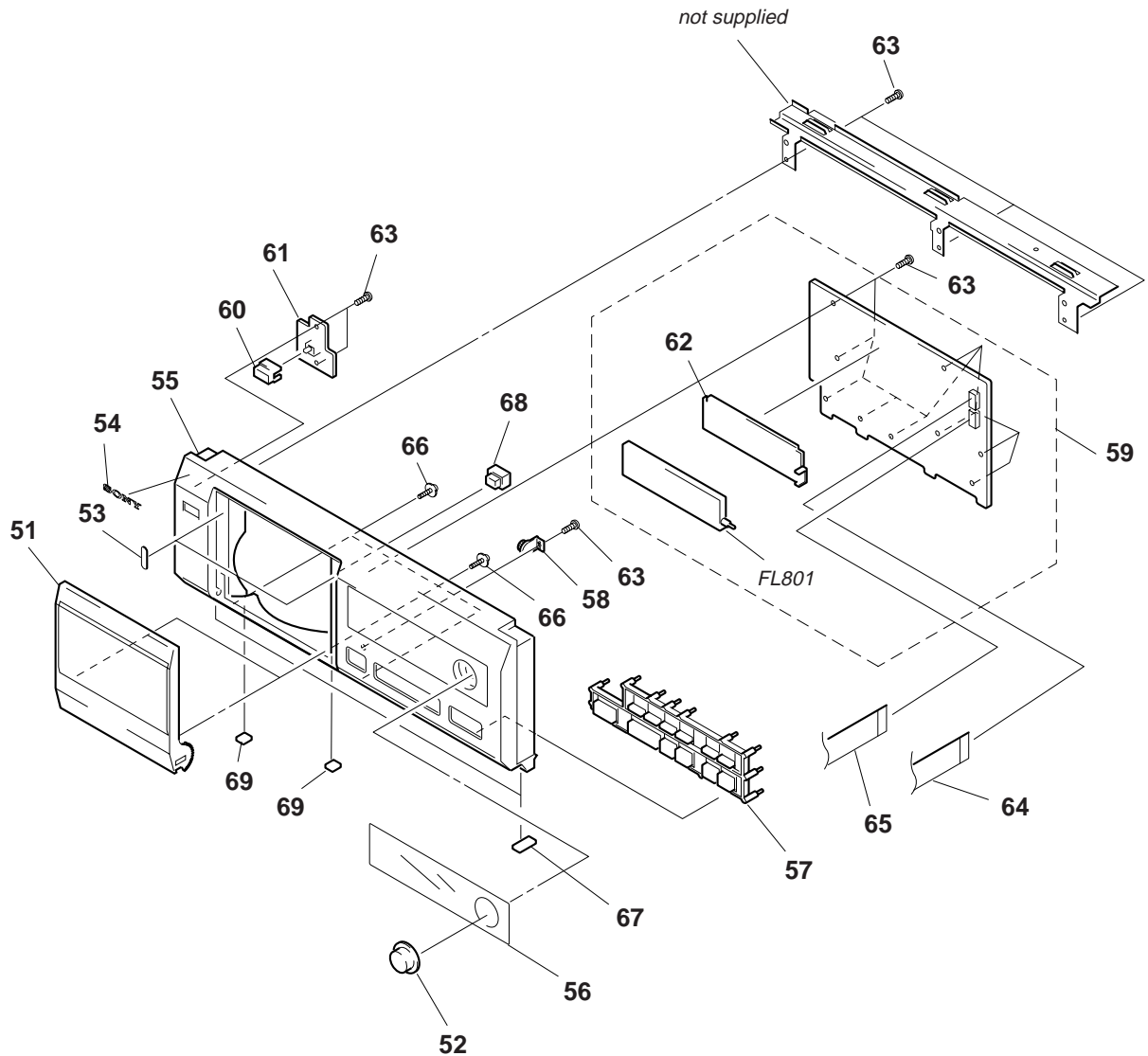

Ref. No.	Part No.	Description	Remark	Ref. No.	Part No.	Description	Remark
51	X-4948-084-1	LID ASSY		* 61	1-664-264-11	POWER SW BOARD	
52	4-987-941-01	KNOB, JOG		* 62	4-987-942-01	HOLDER, FL TUBE	
* 53	4-988-674-01	CUSHION (CLOSE)		63	4-951-620-01	SCREW (2.6X8), +BVTP	
54	3-008-600-01	EMBLEM (5-AR), SONY		64	1-765-321-11	WIRE (FLAT TYPE) (9 CORE)	
55	4-987-877-01	PANEL, FRONT (CX50)		65	1-782-222-11	WIRE (FLAT TYPE) (11 CORE)	
55	4-987-877-21	PANEL, FRONT (CX571)		66	4-933-134-61	SCREW (+PTPWH M2.6X6)	
56	4-987-955-01	WINDOW (FL)		* 67	4-978-398-21	CUSHION	
57	X-4948-480-1	BUTTON (MAIN) ASSY		68	4-989-312-01	LATCH, NS	
58	3-354-963-01	DAMPER		69	4-988-675-01	CUSHION (STOPPER)	
* 59	A-4699-531-A	DISPLAY BOARD, COMPLETE		FL801	1-517-517-11	INDICATOR TUBE, FLUORESCENT	
60	4-977-589-01	BUTTON (POWER)					

### 8-3. CHASSIS SECTION

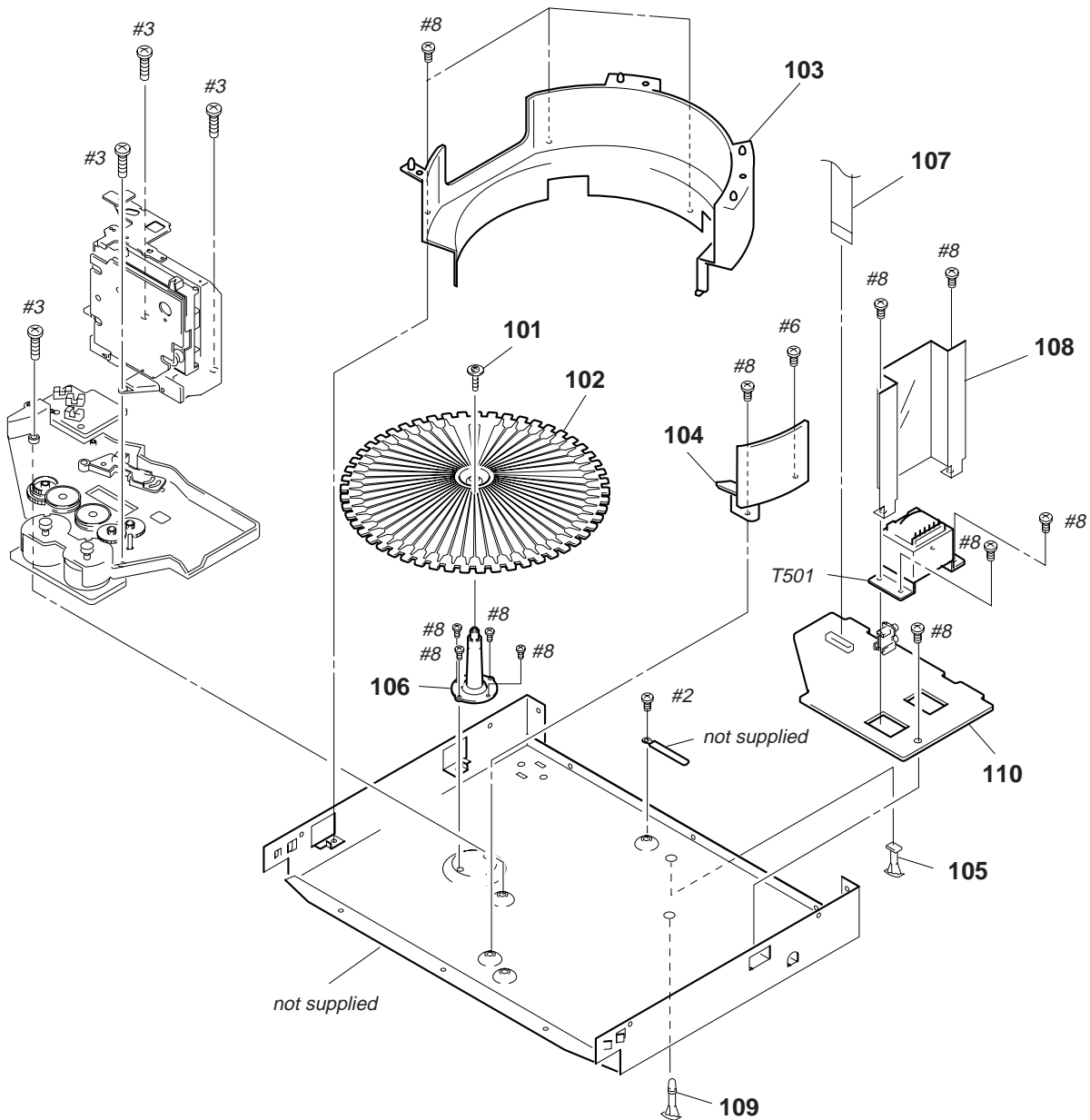

<p>The components identified by mark <math>\triangle</math> or dotted line with mark <math>\triangle</math> are critical for safety. Replace only with part number specified.</p>	<p>Les composants identifiés par une marque <math>\triangle</math> sont critiques pour la sécurité. Ne les remplacer que par une pièce portant le numéro spécifié.</p>
---	--

Ref. No.	Part No.	Description	Remark
101	4-957-577-21	SCREW PTP WH (2.6X8) (DIA. 10)	
102	4-988-434-01	TABLE (50)	
103	4-990-028-01	RING (A)	
104	4-990-029-01	RING (B)	
* 105	4-990-895-01	SUPPORT (P TYPE), LSR	
106	4-988-439-01	HOLDER, TABLE	
107	1-782-221-11	WIRE (FLAT TYPE) (10 CORE)	
* 108	4-991-167-01	COVER, TRANSFORMER	
* 109	3-704-198-51	SUPPORT, PC	
* 110	A-4699-533-A	AUDIO BOARD, COMPLETE (US,CND)	

Ref. No.	Part No.	Description	Remark
* 110	A-4699-534-A	AUDIO BOARD, COMPLETE (CX50:AEP,G,SP,AUS/CX571:AEP,G,UK)	
* 110	A-4699-535-A	AUDIO BOARD, COMPLETE (CX50:E/CX571:E,SP,AUS)	
$\triangle$ T501	1-429-670-21	TRANSFORMER, POWER (US,CND)	
$\triangle$ T501	1-429-671-21	TRANSFORMER, POWER (CX50:AEP,G,SP,AUS/CX571:AEP,G,UK)	
$\triangle$ T501	1-429-672-21	TRANSFORMER, POWER (CX50:E/CX571:E,SP,AUS)	

### 8-4. MECHANISM DECK SECTION 1 (CDM-46)

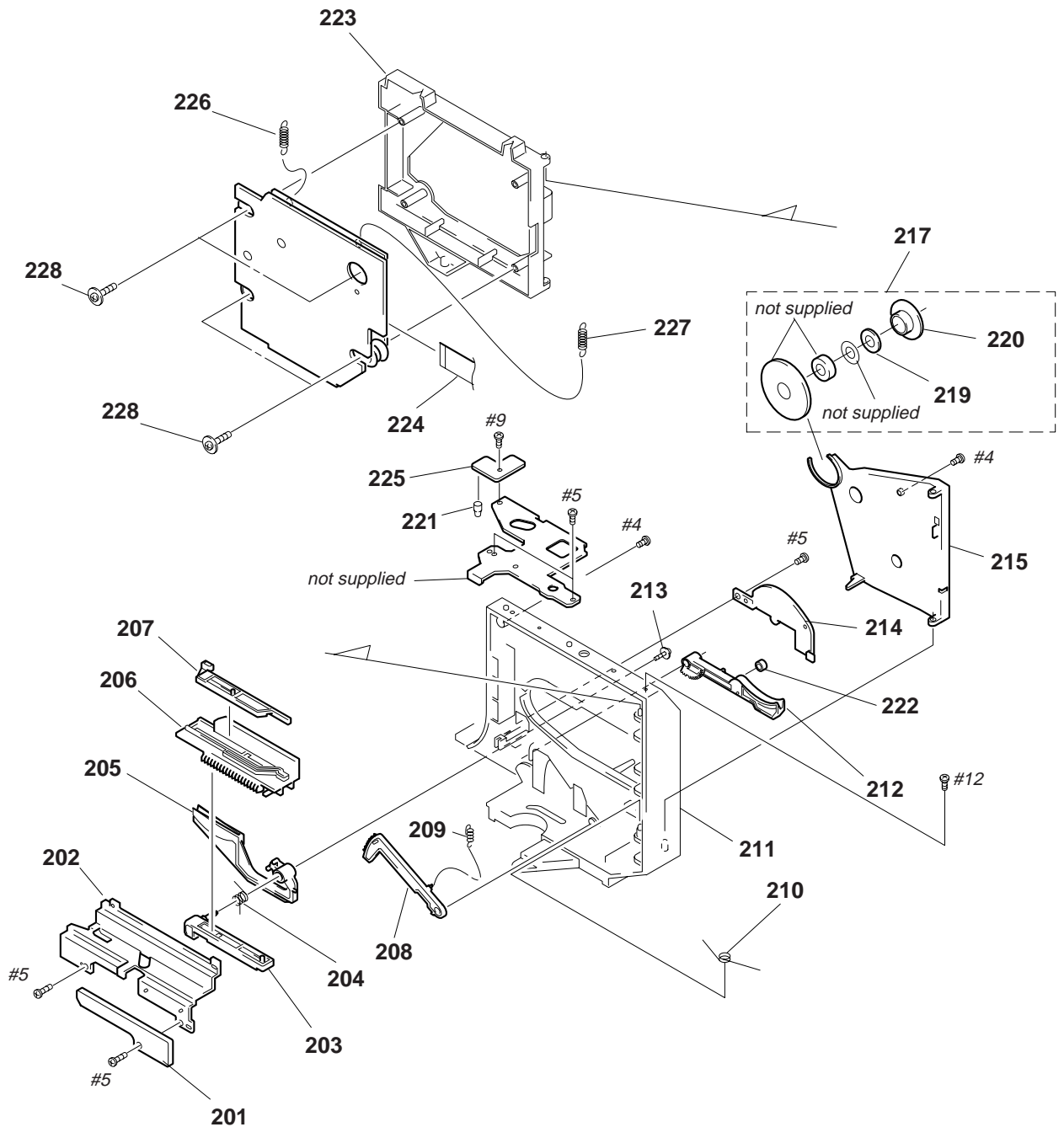

Ref. No.	Part No.	Description	Remark	Ref. No.	Part No.	Description	Remark
* 201	1-663-975-11	SW BOARD		* 215	4-988-421-01	HOLDER (MAGNET)	
* 202	4-988-427-01	COVER, CAM		217	A-4672-385-A	MAGNET ASSY	
203	4-988-420-01	SLIDER (LOADING)		219	4-960-633-01	YOKE (MAGNET)	
204	4-988-436-01	SPRING (LOADING), TORSION		220	4-960-632-11	PULLEY (B)	
205	4-988-418-01	HOLDER (A), DISC		* 221	4-976-473-01	HOLDER (LED-S)	
* 206	4-988-417-01	SLIDER (CAM)		222	4-988-431-01	ROLLER (DISC)	
207	4-988-433-01	SLIDER (LOCK)		223	X-4948-019-1	HOLDER ASSY, BU	
208	X-4948-020-1	LEVER ASSY, LOADING		224	1-777-874-11	WIRE (FLAT TYPE) (16 CORE)	
209	4-988-438-01	SPRING (LEVER), TENSION COIL		* 225	1-663-973-11	DISC SENSOR (S) BOARD	
210	4-988-437-01	SPRING (HOLDER), TORSION		226	4-988-440-01	SPRING (F-1), TENSION COIL	
* 211	4-988-416-01	BASE, LOADING		227	4-988-441-01	SPRING (F-2), TENSION COIL	
212	4-988-419-01	HOLDER (B), DISC		228	4-957-577-21	SCREW PTP WH (2.6X8) (DIA. 10)	
213	4-992-069-01	SCREW +BTP 2.6X8 TYPE2 N-S					
* 214	4-988-454-01	COVER (LEVER)					

## 8-5. MECHANISM DECK SECTION 2 (CDM-46)

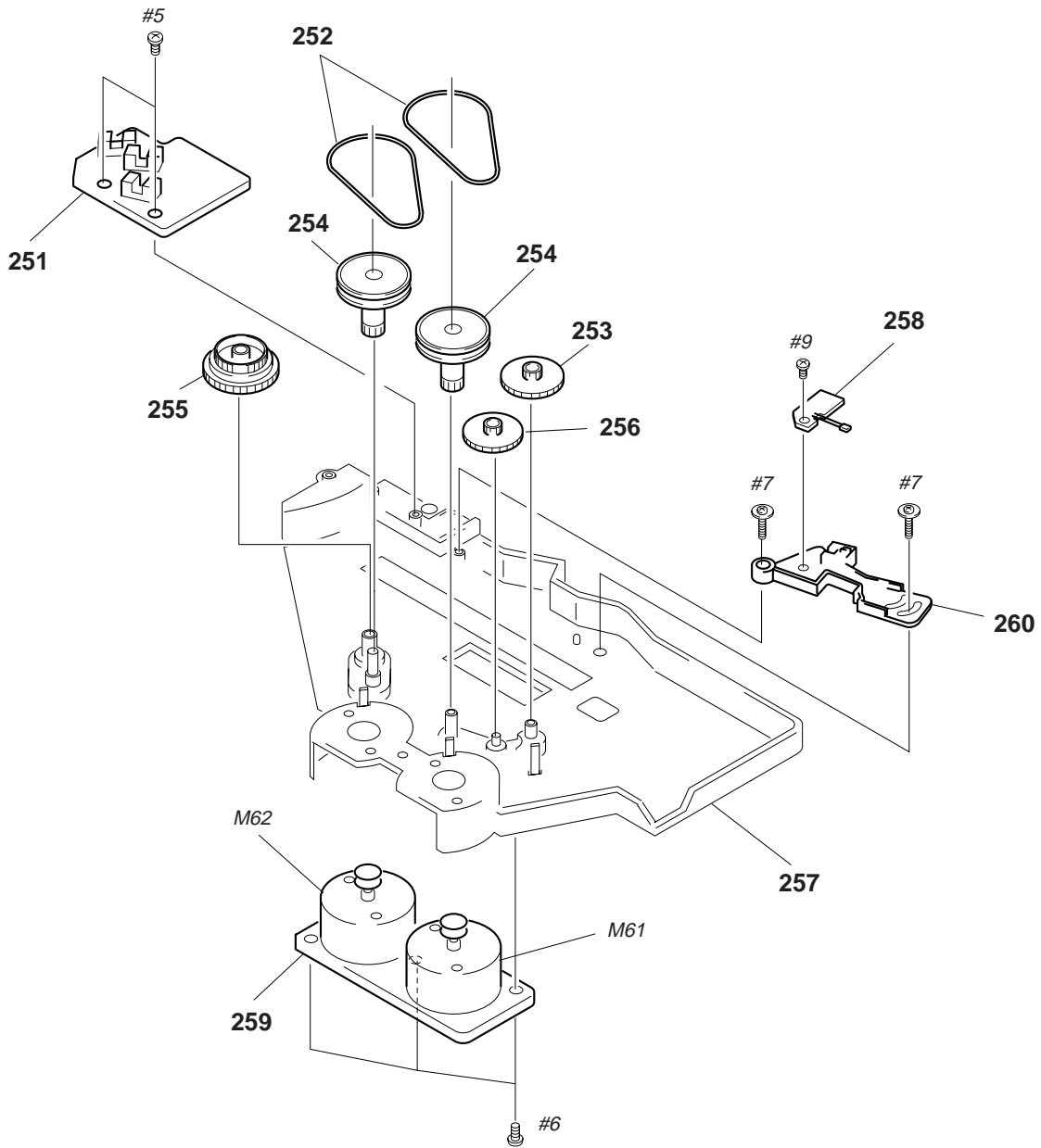

Ref. No.	Part No.	Description	Remark	Ref. No.	Part No.	Description	Remark
* 251	1-663-971-11	TABLE SENSOR BOARD		* 257	4-988-426-01	BASE (CDM)	
252	4-988-414-01	BELT		* 258	1-663-972-11	DISC SENSOR (R) BOARD	
253	4-988-423-01	GEAR (A) (LOADING)		* 259	1-663-974-11	MOTOR BOARD	
254	4-988-425-01	PULLEY		* 260	4-990-669-01	HOLDER (SENSOR)	
255	4-988-424-01	GEAR (TABLE)		M61	X-4948-434-1	MOTOR ASSY (LOADING)	
256	4-988-432-01	GEAR (B) (LOADING)		M62	X-4948-434-1	MOTOR ASSY (TABLE)	

## 8-6. OPTICAL PICK-UP SECTION (KSM-213 BFN/M-NP)

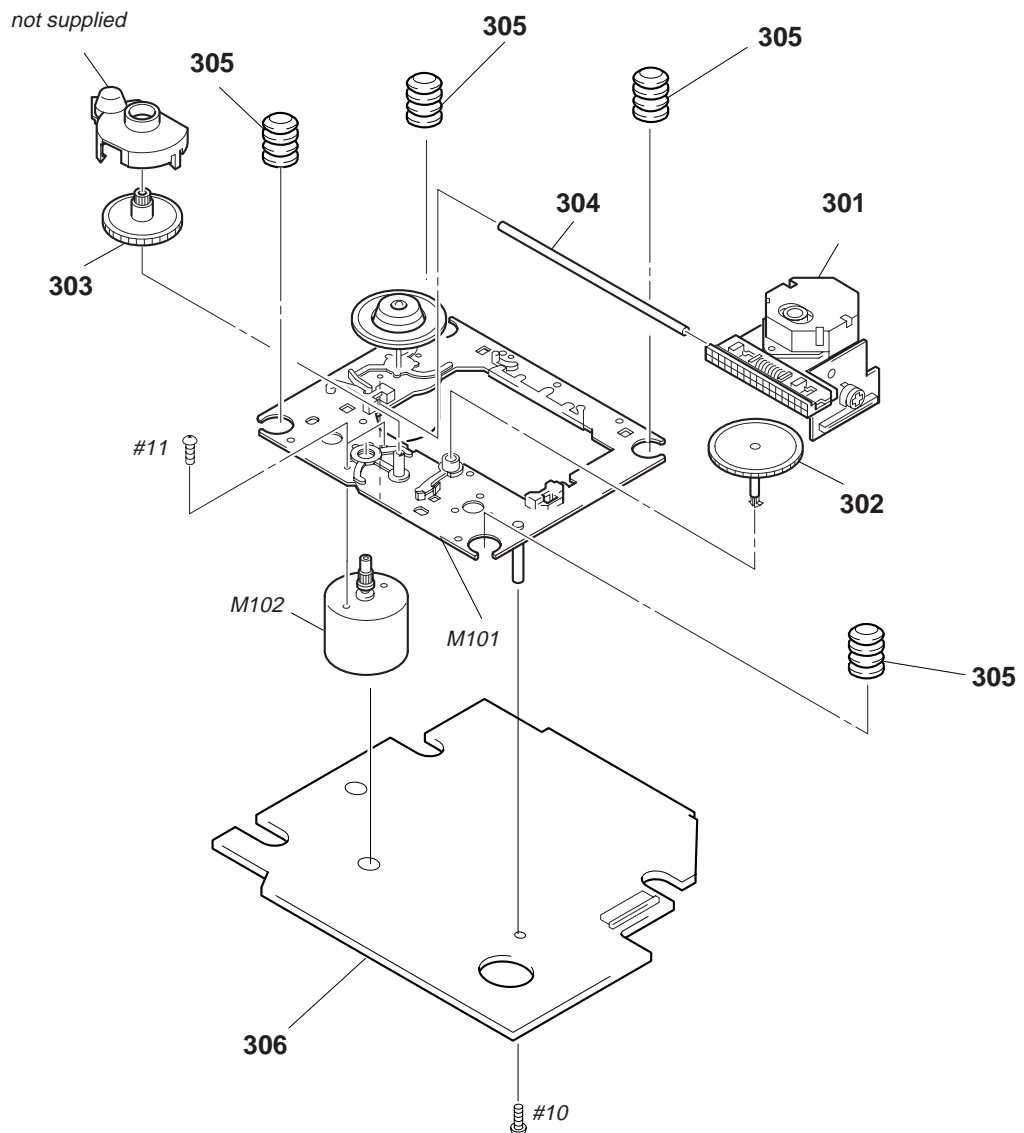

<p>The components identified by mark <math>\Delta</math> or dotted line with mark <math>\Delta</math> are critical for safety. Replace only with part number specified.</p>	<p>Les composants identifiés par une marque <math>\Delta</math> sont critiques pour la sécurité. Ne les remplacer que par une pièce portant le numéro spécifié.</p>
---	---

Ref. No.	Part No.	Description	Remark	Ref. No.	Part No.	Description	Remark
$\Delta$ 301	8-848-379-31	OPTICAL PICK-UP KSS-213B/S-N		305	4-992-054-01	RUBBER, VIBRATION PROOF	
302	2-626-907-01	GEAR (A)(S)		M101	X-2646-110-1	T.T CHASSIS ASSY (MG)(F)(SPINDLE)	
303	2-627-003-02	GEAR (B)(RP)		M102	X-2625-769-1	MOTOR GEAR ASSY (MB)(RP)(SLED)	
304	2-626-908-01	SHAFT, SLED					
* 306	A-4699-536-A	BD BOARD, COMPLETE					

**SECTION 9  
ELECTRICAL PARTS LIST**

**Note:**

The components identified by mark  $\Delta$  or dotted line with mark  $\Delta$  are critical for safety. Replace only with part number specified.

Les composants identifiés par une marque  $\Delta$  sont critiques pour la sécurité. Ne les remplacer que par une pièce portant le numéro spécifié.

When indicating parts by reference number, please include the board name.

- Due to standardization, replacements in the parts list may be different from the parts specified in the diagrams or the components used on the set.
- Items marked "\*" are not stocked since they are seldom required for routine service. Some delay should be anticipated when ordering these items.
- RESISTORS  
All resistors are in ohms  
METAL: Metal-film resistor  
METAL OXIDE: Metal Oxide-film resistor  
F : nonflammable
- SEMICONDUCTORS  
In each case, u:  $\mu$ , for example:  
uA...:  $\mu$  A..., uPA...:  $\mu$  PA..., uPB...:  $\mu$  PB...,  
uPC...:  $\mu$  PC..., uPD...:  $\mu$  PD...
- CAPACITORS  
uF :  $\mu$  F
- COILS  
uH :  $\mu$  H
- Abbreviation  
CND : Canadian model  
G : German model  
SP : Singapore model  
AUS : Australian model

Ref. No.	Part No.	Description	Remark	Ref. No.	Part No.	Description	Remark
*	A-4699-533-A	AUDIO BOARD, COMPLETE (US,CND) *****				< GROUND TERMINAL >	
*	A-4699-534-A	AUDIO BOARD, COMPLETE ***** (CX50:AEP,G,SP,AUS/CX571:AEP,G,UK)		CP2	1-537-771-21	TERMINAL BOARD, GROUND  < DIODE >	
*	A-4699-535-A	AUDIO BOARD, COMPLETE ***** (CX50:E/CX571:E,SP,AUS)  < CAPACITOR >		D301	8-719-987-63	DIODE 1N4148M	
C301	1-162-290-31	CERAMIC	470PF 10% 50V	D701	8-719-200-82	DIODE 11ES2	
C302	1-126-933-11	ELECT	100uF 20% 10V	D702	8-719-200-82	DIODE 11ES2	
C303	1-130-482-00	MYLAR	0.0082uF 5% 50V	D703	8-719-200-82	DIODE 11ES2	
C304	1-106-343-00	MYLAR	1000PF 5% 200V	D704	8-719-200-82	DIODE 11ES2	
C401	1-162-290-31	CERAMIC	470PF 10% 50V				
C402	1-126-933-11	ELECT	100uF 20% 10V	D705	8-719-200-82	DIODE 11ES2	
C403	1-130-482-00	MYLAR	0.0082uF 5% 50V	D706	8-719-924-16	DIODE MTZJ-T-77-24	
C404	1-106-343-00	MYLAR	1000PF 5% 200V	D707	8-719-921-54	DIODE MTZJ-6.2B	
C501	1-126-933-11	ELECT	100uF 20% 10V	D708	8-719-987-63	DIODE 1N4148M	
C504	1-126-933-11	ELECT	100uF 20% 10V	D709	8-719-921-42	DIODE MTZJ-5.1A	
C505	1-126-962-11	ELECT	3.3uF 20% 50V				
C511	1-161-494-00	CERAMIC	0.022uF 25V	D710	8-719-987-63	DIODE 1N4148M	
C701	1-126-936-11	ELECT	3300uF 20% 16V			< IC >	
C702	1-126-767-11	ELECT	1000uF 20% 16V	IC501	8-759-634-51	IC M5218AP	
C703	1-126-968-11	ELECT	100uF 20% 50V	IC502	8-759-634-51	IC M5218AP	
C704	1-126-965-11	ELECT	22uF 20% 50V	IC601	8-759-356-03	IC BA6780	
C706	1-126-963-11	ELECT	4.7uF 20% 50V	IC701	8-759-061-65	IC LA5602	
C707	1-126-963-11	ELECT	4.7uF 20% 50V	IC702	8-749-011-78	IC BA17807T	
C708	1-126-935-11	ELECT	470uF 20% 6.3V			< JACK >	
C709	1-126-963-11	ELECT	4.7uF 20% 50V	J501	1-770-719-11	JACK, PIN 2P (LINE OUT)	
C710	1-126-923-11	ELECT	220uF 20% 10V			< COIL >	
C713	1-126-933-11	ELECT	100uF 20% 16V	L501	1-410-513-11	INDUCTOR 22uH	
		< CLIP >		L503	1-410-503-11	INDUCTOR 3.3uH	
CLP4	1-537-584-31	PIN, LEAD		L504	1-412-473-21	INDUCTOR 0uH	
		< CONNECTOR >		L505	1-412-473-21	INDUCTOR 0uH	
* CN501	1-568-955-11	PIN, CONNECTOR 6P				< TRANSISTOR >	
CN504	1-506-468-11	PIN, CONNECTOR 3P		Q301	8-729-141-26	TRANSISTOR 2SC3622A-LK	
CN701	1-580-230-11	PIN, CONNECTOR (PC BOARD) 2P		Q302	8-729-029-56	TRANSISTOR DTA144ESA	
* CN801	1-568-830-11	SOCKET, CONNECTOR 11P		Q303	8-729-030-03	TRANSISTOR DTC144ESA-TP	
* CN803	1-568-934-11	PIN, CONNECTOR 7P		Q313	8-729-141-26	TRANSISTOR 2SC3622A-LK	
				Q401	8-729-141-26	TRANSISTOR 2SC3622A-LK	
* CN811	1-568-829-11	SOCKET, CONNECTOR 10P					
* CN841	1-568-951-11	PIN, CONNECTOR 2P		Q402	8-729-029-56	TRANSISTOR DTA144ESA	
				Q403	8-729-030-03	TRANSISTOR DTC144ESA-TP	
				Q413	8-729-141-26	TRANSISTOR 2SC3622A-LK	
				Q501	8-729-029-56	TRANSISTOR DTA144ESA	
				Q701	8-729-140-97	TRANSISTOR 2SB734-34	
				Q702	8-729-119-76	TRANSISTOR 2SA1175-HFE	



Ref. No.	Part No.	Description	Remark	Ref. No.	Part No.	Description	Remark
		< RESISTOR >		*	A-4699-536-A	BD BOARD, COMPLETE *****	
R301	1-249-413-11	CARBON 470 5%	1/4W F			< CAPACITOR >	
R302	1-249-441-11	CARBON 100K 5%	1/4W				
R303	1-247-862-11	CARBON 20K 5%	1/4W				
R304	1-249-429-11	CARBON 10K 5%	1/4W				
R305	1-249-417-11	CARBON 1K 5%	1/4W F	C101	1-163-038-91	CERAMIC CHIP 0.1uF	25V
R306	1-247-836-11	CARBON 1.6K 5%	1/4W	C102	1-163-038-91	CERAMIC CHIP 0.1uF	25V
R307	1-247-836-11	CARBON 1.6K 5%	1/4W	C103	1-164-489-11	CERAMIC CHIP 0.22uF	10% 16V
R311	1-249-421-11	CARBON 2.2K 5%	1/4W F	C104	1-163-003-11	CERAMIC CHIP 330PF	10% 50V
R312	1-249-441-11	CARBON 100K 5%	1/4W	C105	1-163-023-00	CERAMIC CHIP 0.015uF	5% 50V
R313	1-249-421-11	CARBON 2.2K 5%	1/4W F	C106	1-110-501-11	CERAMIC CHIP 0.33uF	10% 16V
R314	1-249-413-11	CARBON 470 5%	1/4W	C107	1-163-989-11	CERAMIC CHIP 0.033uF	10% 25V
R401	1-249-413-11	CARBON 470 5%	1/4W F	C108	1-164-492-11	CERAMIC CHIP 0.15uF	10% 16V
R402	1-249-441-11	CARBON 100K 5%	1/4W	C109	1-164-182-11	CERAMIC CHIP 0.0033uF	10% 50V
R403	1-247-862-11	CARBON 20K 5%	1/4W	C110	1-163-809-11	CERAMIC CHIP 0.047uF	10% 25V
R404	1-249-429-11	CARBON 10K 5%	1/4W	C111	1-164-492-11	CERAMIC CHIP 0.15uF	10% 16V
R405	1-249-417-11	CARBON 1K 5%	1/4W F	C112	1-163-009-11	CERAMIC CHIP 0.001uF	10% 50V
R406	1-247-836-11	CARBON 1.6K 5%	1/4W	C113	1-164-492-11	CERAMIC CHIP 0.15uF	10% 16V
R407	1-247-836-11	CARBON 1.6K 5%	1/4W	C114	1-164-492-11	CERAMIC CHIP 0.15uF	10% 16V
R411	1-249-421-11	CARBON 2.2K 5%	1/4W F	C115	1-164-232-11	CERAMIC CHIP 0.01uF	50V
R412	1-249-441-11	CARBON 100K 5%	1/4W	C116	1-164-232-11	CERAMIC CHIP 0.01uF	50V
R413	1-249-421-11	CARBON 2.2K 5%	1/4W F	C117	1-163-001-11	CERAMIC CHIP 220PF	10% 50V
R414	1-249-413-11	CARBON 470 5%	1/4W	C118	1-107-823-11	CERAMIC CHIP 0.47uF	10% 16V
R501	1-247-807-31	CARBON 100 5%	1/4W	C119	1-164-489-11	CERAMIC CHIP 0.22uF	10% 16V
R502	1-249-441-11	CARBON 100K 5%	1/4W	C120	1-123-622-91	ELECT 22uF	20% 50V
R601	1-249-382-11	CARBON 1.2 5%	1/6W F	C121	1-164-182-11	CERAMIC CHIP 0.0033uF	10% 50V
R602	1-249-382-11	CARBON 1.2 5%	1/6W F	C122	1-126-963-11	ELECT 4.7uF	20% 50V
R603	1-249-429-11	CARBON 10K 5%	1/4W	C123	1-163-038-91	CERAMIC CHIP 0.1uF	25V
R604	1-247-850-11	CARBON 6.2K 5%	1/4W	C124	1-123-617-91	ELECT 10uF	20% 50V
R605	1-249-429-11	CARBON 10K 5%	1/4W	C125	1-123-661-91	ELECT 100uF	20% 10V
R606	1-249-428-11	CARBON 8.2K 5%	1/4W F	C126	1-123-661-91	ELECT 100uF	20% 10V
R701	1-249-425-11	CARBON 4.7K 5%	1/4W F	C127	1-163-989-11	CERAMIC CHIP 0.033uF	10% 25V
R702	1-249-429-11	CARBON 10K 5%	1/4W	C128	1-163-809-11	CERAMIC CHIP 0.047uF	10% 25V
R703	1-249-438-11	CARBON 56K 5%	1/4W	C129	1-110-501-11	CERAMIC CHIP 0.33uF	10% 16V
R704	1-249-431-11	CARBON 15K 5%	1/4W	C130	1-124-443-00	ELECT 100uF	20% 10V
R705	1-249-429-11	CARBON 10K 5%	1/4W	C131	1-163-009-11	CERAMIC CHIP 0.001uF	10% 50V
R706	1-249-411-11	CARBON 330 5%	1/4W	C132	1-163-038-91	CERAMIC CHIP 0.1uF	25V
		< VARIABLE RESISTOR >		C133	1-163-038-91	CERAMIC CHIP 0.1uF	25V
RV502	1-241-768-11	RES, ADJ, CARBON 220K		C141	1-163-038-91	CERAMIC CHIP 0.1uF	25V
		< SWITCH >		C151	1-164-004-11	CERAMIC CHIP 0.1uF	10% 25V
△S501	1-572-675-11	SWITCH, POWER VOLTAGE CHANGE (VOLTAGE SELECTOR)(CX50:E/CX571:E,SP,AUS)		C152	1-164-004-11	CERAMIC CHIP 0.1uF	10% 25V
		< TRANSFORMER >		C153	1-164-004-11	CERAMIC CHIP 0.1uF	10% 25V
△T501	1-429-670-21	TRANSFORMER, POWER (US,CND)		C154	1-163-009-11	CERAMIC CHIP 0.001uF	10% 50V
△T501	1-429-671-21	TRANSFORMER, POWER (CX50:AEP,G,SP,AUS/CX571:AEP,G,UK)		C155	1-163-093-00	CERAMIC CHIP 10PF	5% 50V
△T501	1-429-672-21	TRANSFORMER, POWER (CX50:E/CX571:E,SP,AUS)		C156	1-163-085-00	CERAMIC CHIP 2PF	50V
		< TEST PIN >		C157	1-164-232-11	CERAMIC CHIP 0.01uF	50V
* TP501	1-564-506-11	PLUG, CONNECTOR 3P		C158	1-163-038-91	CERAMIC CHIP 0.1uF	25V
		*****		C159	1-163-101-00	CERAMIC CHIP 22PF	5% 50V
				C160	1-163-117-00	CERAMIC CHIP 100PF	5% 50V
				C161	1-163-038-91	CERAMIC CHIP 0.1uF	25V
				C162	1-163-038-91	CERAMIC CHIP 0.1uF	25V
				C163	1-163-038-91	CERAMIC CHIP 0.1uF	25V
				C164	1-163-227-11	CERAMIC CHIP 10PF	0.5PF 50V
				C165	1-163-227-11	CERAMIC CHIP 10PF	0.5PF 50V
				C166	1-124-443-00	ELECT 100uF	20% 10V
				C167	1-163-038-91	CERAMIC CHIP 0.1uF	25V
				C171	1-163-038-91	CERAMIC CHIP 0.1uF	25V
				C172	1-123-661-91	ELECT 100uF	20% 10V
				C173	1-124-589-11	ELECT 47uF	20% 16V

The components identified by mark △ or dotted line with mark △ are critical for safety. Replace only with part number specified.

Les composants identifiés par une marque △ sont critiques pour la sécurité. Ne les remplacer que par une pièce portant le numéro spécifié.



Ref. No.	Part No.	Description	Remark	Ref. No.	Part No.	Description	Remark
C175	1-163-038-91	CERAMIC CHIP 0.1uF	25V	R122	1-216-083-00	METAL CHIP 27K	5% 1/10W
C181	1-104-664-11	ELECT 47uF	20% 16V	R123	1-216-099-00	METAL CHIP 120K	5% 1/10W
C182	1-104-664-11	ELECT 47uF	20% 16V	R124	1-216-093-00	METAL CHIP 68K	5% 1/10W
C183	1-163-003-11	CERAMIC CHIP 330PF	10% 50V	R125	1-216-089-91	METAL GLAZE 47K	5% 1/10W
C184	1-163-003-11	CERAMIC CHIP 330PF	10% 50V	R126	1-216-037-00	METAL CHIP 330	5% 1/10W
< CONNECTOR >				R127	1-216-089-91	METAL GLAZE 47K	5% 1/10W
CN101	1-770-173-11	CONNECTOR, FFC/FPC 16P		R128	1-216-077-00	METAL CHIP 15K	5% 1/10W
CN102	1-568-853-11	SOCKET, CONNECTOR 10P		R129	1-216-069-00	METAL CHIP 6.8K	5% 1/10W
* CN103	1-568-852-11	SOCKET, CONNECTOR 9P		R130	1-216-113-00	METAL CHIP 470K	5% 1/10W
< IC >				R131	1-216-113-00	METAL CHIP 470K	5% 1/10W
IC101	8-759-449-64	IC LA9240M		R132	1-216-065-00	METAL CHIP 4.7K	5% 1/10W
IC102	8-759-449-65	IC LC78622E		R133	1-216-113-00	METAL CHIP 470K	5% 1/10W
IC103	8-759-449-66	IC LA6541		R134	1-216-113-00	METAL CHIP 470K	5% 1/10W
< JUMPER RESISTOR >				R135	1-216-065-00	METAL CHIP 4.7K	5% 1/10W
JW1	1-216-295-91	CONDUCTOR, CHIP (2012)		R136	1-216-073-00	METAL CHIP 10K	5% 1/10W
JW2	1-216-295-91	CONDUCTOR, CHIP (2012)		R137	1-216-009-00	METAL CHIP 22	5% 1/10W
JW3	1-216-295-91	CONDUCTOR, CHIP (2012)		R151	1-216-045-00	METAL CHIP 680	5% 1/10W
JW6	1-216-295-91	CONDUCTOR, CHIP (2012)		R152	1-216-093-00	METAL CHIP 68K	5% 1/10W
JW7	1-216-295-91	CONDUCTOR, CHIP (2012)		R153	1-216-051-00	METAL CHIP 1.2K	5% 1/10W
JW8	1-216-295-91	CONDUCTOR, CHIP (2012)		R154	1-216-085-00	METAL CHIP 33K	5% 1/10W
JW9	1-216-295-91	CONDUCTOR, CHIP (2012)		R155	1-216-089-91	METAL GLAZE 47K	5% 1/10W
JW10	1-216-295-91	CONDUCTOR, CHIP (2012)		R156	1-216-081-00	METAL CHIP 22K	5% 1/10W
< MOTOR >				R157	1-216-077-00	METAL CHIP 15K	5% 1/10W
M101	X-2646-110-1	MOTOR ASSY (SPINDLE)		R158	1-216-049-91	METAL GLAZE 1K	5% 1/10W
M102	X-2625-769-1	MOTOR ASSY (SLED)		R159	1-216-083-00	METAL CHIP 27K	5% 1/10W
< TRANSISTOR >				R160	1-216-037-00	METAL CHIP 330	5% 1/10W
Q101	8-729-119-78	TRANSISTOR 2SC2785-HFE		R161	1-216-073-00	METAL CHIP 10K	5% 1/10W
Q102	8-729-119-78	TRANSISTOR 2SC2785-HFE		R163	1-216-049-91	METAL GLAZE 1K	5% 1/10W
Q103	8-729-119-76	TRANSISTOR 2SA1175-HFE		R164	1-216-065-00	METAL CHIP 4.7K	5% 1/10W
< RESISTOR >				R165	1-216-025-91	METAL GLAZE 100	5% 1/10W
R101	1-216-097-91	METAL GLAZE 100K	5% 1/10W	R166	1-216-025-91	METAL GLAZE 100	5% 1/10W
R102	1-216-093-00	METAL CHIP 68K	5% 1/10W	R181	1-216-057-00	METAL CHIP 2.2K	5% 1/10W
R103	1-216-093-00	METAL CHIP 68K	5% 1/10W	R182	1-216-057-00	METAL CHIP 2.2K	5% 1/10W
R104	1-216-093-00	METAL CHIP 68K	5% 1/10W	R183	1-216-073-00	METAL CHIP 10K	5% 1/10W
R105	1-216-093-00	METAL CHIP 68K	5% 1/10W	R184	1-216-073-00	METAL CHIP 10K	5% 1/10W
R106	1-216-097-91	METAL GLAZE 100K	5% 1/10W	R191	1-216-025-91	METAL GLAZE 100	5% 1/10W
R107	1-216-097-91	METAL GLAZE 100K	5% 1/10W	R192	1-216-041-91	METAL GLAZE 470	5% 1/10W
R108	1-216-068-00	METAL CHIP 6.2K	5% 1/10W	R193	1-216-041-91	METAL GLAZE 470	5% 1/10W
R109	1-216-076-00	METAL CHIP 13K	5% 1/10W	R194	1-216-025-91	METAL GLAZE 100	5% 1/10W
R110	1-216-093-00	METAL CHIP 68K	5% 1/10W	R195	1-216-041-91	METAL GLAZE 470	5% 1/10W
R111	1-216-057-00	METAL CHIP 2.2K	5% 1/10W	R196	1-216-025-91	METAL GLAZE 100	5% 1/10W
R112	1-216-083-00	METAL CHIP 27K	5% 1/10W	R197	1-216-025-91	METAL GLAZE 100	5% 1/10W
R113	1-216-105-91	METAL GLAZE 220K	5% 1/10W	< SWITCH >			
R114	1-216-043-91	METAL GLAZE 560	5% 1/10W	S101	1-572-085-11	SWITCH, LEAF (LIMIT)	
R115	1-216-077-00	METAL CHIP 15K	5% 1/10W	< VIBRATOR >			
R116	1-216-057-00	METAL CHIP 2.2K	5% 1/10W	X101	1-577-576-21	VIBRATOR, CRYSTAL (16.9344MHz)	
R117	1-216-085-00	METAL CHIP 33K	5% 1/10W	*****			
R118	1-216-081-00	METAL CHIP 22K	5% 1/10W	*	1-663-972-11	DISC SENSOR (R) BOARD	*****
R119	1-216-069-00	METAL CHIP 6.8K	5% 1/10W	*****			
R120	1-216-085-00	METAL CHIP 33K	5% 1/10W	*	4-988-413-01	HOLDER, SENSOR	
R121	1-216-059-00	METAL CHIP 2.7K	5% 1/10W	< TRANSISTOR >			
				Q51	8-729-926-31	PHOTO TRANSISTOR PT483F1S	
*****							

**DISC SENSOR (S)**

**DISPLAY**

**LED**

Ref. No.	Part No.	Description	Remark
*	1-663-973-11	DISC SENSOR (S) BOARD *****	
*	4-976-473-01	HOLDER (LED-S)  < CONNECTOR >	
CN53	1-568-951-11	PIN, CONNECTOR 2P  < DIODE >	
D51	8-719-055-84	DIODE GL-528VS1 (DISC SENSOR)  < RESISTOR >	
R54	1-249-409-11	CARBON 220 5% 1/4W F	
*****			
*	A-4699-531-A	DISPLAY BOARD, COMPLETE *****	
*	4-987-942-01	HOLDER, FL TUBE  < CAPACITOR >	
C801	1-126-933-11	ELECT 100uF 20% 10V	
C802	1-161-494-00	CERAMIC 0.022uF 25V	
C803	1-161-494-00	CERAMIC 0.022uF 25V	
C805	1-126-933-11	ELECT 100uF 20% 10V	
< CONNECTOR >			
* CNP801	1-568-830-11	SOCKET, CONNECTOR 11P	
* CNP804	1-568-828-11	SOCKET, CONNECTOR 9P  < DIODE >	
D801	8-719-018-46	DIODE SEL3510C-CD (▷)	
D802	8-719-313-50	DIODE SEL6810A-TH12 (■)	
D803	8-719-313-50	DIODE SEL6810A-TH12 (PLUS ONE)  < FLUORESCENT INDICATOR >	
FL801	1-517-517-11	INDICATOR TUBE, FLUORESCENT  < IC >	
IC801	8-752-875-94	IC CXP82320-074Q	
IC802	8-759-459-84	IC NJL56H400  < TRANSISTOR >	
Q801	8-729-030-03	TRANSISTOR DTC144ESA-TP	
Q811	8-729-030-03	TRANSISTOR DTC144ESA-TP  < RESISTOR >	
R800	1-249-427-11	CARBON 6.8K 5% 1/4W F	
R801	1-249-415-11	CARBON 680 5% 1/4W F	
R802	1-249-417-11	CARBON 1K 5% 1/4W F	
R803	1-249-419-11	CARBON 1.5K 5% 1/4W F	
R804	1-249-421-11	CARBON 2.2K 5% 1/4W F	
R805	1-247-843-11	CARBON 3.3K 5% 1/4W	
R806	1-249-427-11	CARBON 6.8K 5% 1/4W F	
R810	1-249-427-11	CARBON 6.8K 5% 1/4W F	
R811	1-249-415-11	CARBON 680 5% 1/4W F	
R812	1-249-417-11	CARBON 1K 5% 1/4W F	

Ref. No.	Part No.	Description	Remark
R813	1-249-419-11	CARBON 1.5K 5% 1/4W F	
R814	1-249-421-11	CARBON 2.2K 5% 1/4W F	
R815	1-247-843-11	CARBON 3.3K 5% 1/4W	
R821	1-249-429-11	CARBON 10K 5% 1/4W	
R822	1-249-429-11	CARBON 10K 5% 1/4W	
R823	1-249-429-11	CARBON 10K 5% 1/4W	
R824	1-249-429-11	CARBON 10K 5% 1/4W	
R826	1-249-429-11	CARBON 10K 5% 1/4W	
R827	1-249-429-11	CARBON 10K 5% 1/4W	
R828	1-249-437-11	CARBON 47K 5% 1/4W	
R829	1-249-429-11	CARBON 10K 5% 1/4W	
R830	1-247-807-31	CARBON 100 5% 1/4W	
R831	1-249-407-11	CARBON 150 5% 1/4W F	
R832	1-249-410-11	CARBON 270 5% 1/4W F	
R833	1-247-807-31	CARBON 100 5% 1/4W	
R834	1-249-429-11	CARBON 10K 5% 1/4W	
R835	1-249-429-11	CARBON 10K 5% 1/4W	
R836	1-249-410-11	CARBON 270 5% 1/4W F	
< ROTARY ENCODER >			
RE801	1-473-957-11	ENCODER, ROTARY (DISC/PUSH ENTER)  < SWITCH >	
S801	1-554-303-21	SWITCH, TACTILE (■)	
S802	1-554-303-21	SWITCH, TACTILE (■)	
S803	1-554-303-21	SWITCH, TACTILE (▷)	
S804	1-554-303-21	SWITCH, TACTILE (◀◀◀ ◀◀)	
S805	1-554-303-21	SWITCH, TACTILE (▶▶ ▶▶▶)	
S806	1-554-303-21	SWITCH, TACTILE (CHECK)	
S807	1-554-303-21	SWITCH, TACTILE (CLEAR)	
S811	1-554-303-21	SWITCH, TACTILE (PLUS ONE)	
S812	1-554-303-21	SWITCH, TACTILE (CONTINUE)	
S813	1-554-303-21	SWITCH, TACTILE (SHUFFLE)	
S814	1-554-303-21	SWITCH, TACTILE (PROGRAM)	
S815	1-554-303-21	SWITCH, TACTILE (REPEAT)	
S821	1-762-936-11	SWITCH, LEVER (PUSH OPEN)	
< VIBRATOR >			
X801	1-579-175-11	VIBRATOR, CERAMIC (10MHz)	
*****			
*	1-665-903-11	LED BOARD *****  < CONNECTOR >	
CNP841	1-506-481-11	PIN, CONNECTOR 2P  < DIODE >	
D841	8-719-057-10	DIODE LNJ301MPUJA (INSIDE ILLUMINATION)	
D842	8-719-057-09	DIODE LNJ801LPDJA (INSIDE ILLUMINATION)	
D843	8-719-064-21	DIODE LNJ801TPSJA (INSIDE ILLUMINATION)  < RESISTOR >	
R841	1-249-407-11	CARBON 150 5% 1/4W F	
R842	1-249-408-11	CARBON 180 5% 1/4W F	
R843	1-249-410-11	CARBON 270 5% 1/4W F	
*****			

<b>MOTOR</b>	<b>POWER SW</b>	<b>SW</b>	<b>TABLE SENSOR</b>
--------------	-----------------	-----------	---------------------

Ref. No.	Part No.	Description	Remark
*	1-663-974-11	MOTOR BOARD *****	
		< CONNECTOR >	
CN61	1-506-469-11	PIN, CONNECTOR 4P	
		< CLIP >	
CP1	1-597-584-11	PIN LEAD	
		< MOTOR >	
M61	X-4948-434-1	MOTOR ASSY (LOADING)	
M62	X-4948-434-1	MOTOR ASSY (TABLE)	
*****			
*	1-664-264-11	POWER SW BOARD *****	
		< CONNECTOR >	
* CN802	1-568-942-11	PIN, CONNECTOR 4P	
		< SWITCH >	
S822	1-554-118-00	SWITCH, PUSH (1 KEY)(POWER)	
*****			
*	1-663-975-11	SW BOARD *****	
		< CONNECTOR >	
* CN54	1-568-941-11	PIN, CONNECTOR 3P	
		< SWITCH >	
S51	1-571-958-11	SWITCH, PUSH (1 KEY) (UP)	
S52	1-571-958-11	SWITCH, PUSH (1 KEY) (DOWN)	
*****			
*	1-663-971-11	TABLE SENSOR BOARD *****	
		< CONNECTOR >	
* CN51	1-568-944-11	PIN, CONNECTOR 6P	
CN52	1-506-481-11	PIN, CONNECTOR 2P	
		< IC >	
IC51	8-749-924-18	IC PHOTO INTERRUPTER RPI-1391	
IC52	8-749-924-18	IC PHOTO INTERRUPTER RPI-1391	
IC53	8-749-924-18	IC PHOTO INTERRUPTER RPI-1391	
		< RESISTOR >	
R51	1-249-416-11	CARBON	820 5% 1/4W F
R52	1-249-416-11	CARBON	820 5% 1/4W F
R53	1-249-416-11	CARBON	820 5% 1/4W F
*****			

Ref. No.	Part No.	Description	Remark
		MISCELLANEOUS *****	
△ 9	1-558-943-61	CORD, POWER (E)	
△ 9	1-575-651-21	CORD, POWER (CX50:AEP,G,SP/CX571:AEP,G,SP,AUS)	
△ 9	1-590-926-11	CORD, POWER (US,CND)	
△ 9	1-696-845-11	CORD, POWER (CX50:AUS)	
△ 9	1-769-639-11	CORD, POWER (CX571:UK)	
△ 10	1-569-007-11	ADAPTOR, CONVERSION 2P (CX50:E)	
64	1-765-321-11	WIRE (FLAT TYPE) (9 CORE)	
65	1-782-222-11	WIRE (FLAT TYPE) (11 CORE)	
112	1-782-221-11	WIRE (FLAT TYPE) (10 CORE)	
217	1-452-367-12	MAGNET	
224	1-777-874-11	WIRE (FLAT TYPE) (16 CORE)	
△ 301	8-848-379-31	OPTICAL PICK-UP KSS-213B/S-N	
FL801	1-517-517-11	INDICATOR TUBE, FLUORESCENT	
M61	X-4948-434-1	MOTOR ASSY (LOADING)	
M62	X-4948-434-1	MOTOR ASSY (TABLE)	
M101	X-2646-110-1	MOTOR ASSY (SPINDLE)	
M102	X-2625-769-1	MOTOR ASSY (SLED)	
△ T501	1-429-670-21	TRANSFORMER, POWER (US,CND)	
△ T501	1-429-671-21	TRANSFORMER, POWER (CX50:AEP,G,SP,AUS/CX571:AEP,G,UK)	
△ T501	1-429-672-21	TRANSFORMER, POWER (CX50:E/CX571:E,SP,AUS)	
*****			
ACCESSORIES & PACKING MATERIALS *****			
	1-558-271-11	CORD, CONNECTION (AUDIO 108cm)	
	3-858-848-11	MANUAL, INSTRUCTION (ENGLISH) (CX50:US,CND,AEP,G,E,SP,AUS/CX571:US,CND, AEP,G,UK,E,SP,AUS)	
	3-858-848-21	MANUAL, INSTRUCTION (FRENCH,SPANISH,PORTUGUES) (CX50:CND,AEP,G,E,SP/CX571:CND,AEP,G,UK,E, SP)	
	3-858-848-31	MANUAL, INSTRUCTION (CHINESE,DUTCH,ITALIAN) (CX50:AEP,G/ CX571:AEP,G,UK)	
	3-858-848-41	MANUAL, INSTRUCTION (SWEDISH,DANNISH,FINISH) (AEP)	
	3-858-848-51	MANUAL, INSTRUCTION (CHINESE,ARABIC) (CX50:E,SP/CX571:E,SP)	
	4-991-161-01	LET, BOOK (CX50)	
*****			

The components identified by mark △ or dotted line with mark △ are critical for safety. Replace only with part number specified.	Les composants identifiés par une marque △ sont critiques pour la sécurité. Ne les remplacer que par une pièce portant le numéro spécifié.
--	--

<u>Ref. No.</u>	<u>Part No.</u>	<u>Description</u>	<u>Remark</u>
		***** HARDWARE LIST *****	
#1	7-685-645-79	SCREW +BVTP 3X6 TYPE2 N-S	
#2	7-685-871-01	SCREW +BVTT 3X6 (S)	
#3	7-685-873-09	SCREW +BVTT 3X10 (S)	
#4	7-685-107-11	SCREW +P 2X12 TYPE2 NON-SLIT	
#5	7-685-534-19	SCREW +BTP 2.6X8 TYPE2 N-S	
#6	7-685-646-79	SCREW +BVTP 3X8 TYPE2 N-S	
#7	7-621-770-67	SCREW +PWH 2.6X6	
#8	7-685-872-09	SCREW +BVTT 3X8 (S)	
#9	7-685-132-19	SCREW +BTP 2.6X5 TYPE2 N-S	
#10	7-621-772-20	SCREW +B 2X5	
#11	7-682-255-15	SCREW +P 2X3	
#12	7-685-135-19	SCREW +P 2.6X10	

