

CDP-H6600

SERVICE MANUAL

AEP Model
UK Model
E Model

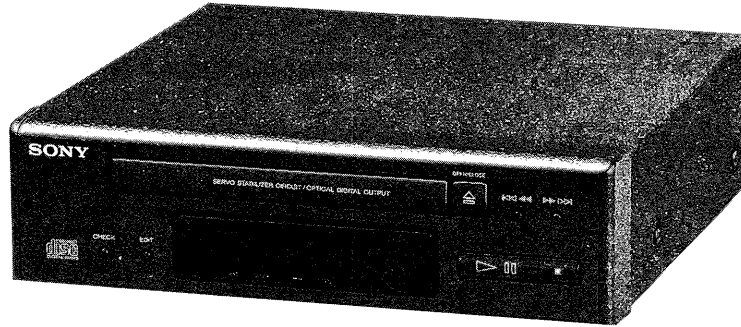

This set is the CD player section in MHC-5600/6600 and FH-E939CD.

Model Name Using Similar Mechanism	CDP-H300
CD Mechanism Type	CDM13B-5BD5
Base Unit Name	BU-5BD5

TABLE OF CONTENTS

<u>Section</u>	<u>Title</u>	<u>Page</u>
1. GENERAL		
	Location of Controls	3
2. ELECTRICAL BLOCK CHECKING		4
3. DIAGRAMS		
3-1.	Block Diagram	7
3-2.	Semiconductor Lead Layouts	10
3-3.	Printed Wiring Boards	10
3-4.	Schematic Diagram - BD Section -	13
3-5.	Schematic Diagram - Main Section -	16
3-6.	IC Block Diagrams	19
3-7.	Pin Function of IC202 and IC401	21
4. EXPLODED VIEWS		
(1)	Chassis Section	23
(2)	CD Mechanism Section	24
(3)	Optical Pick-Up Block	25
5. ELECTRICAL PARTS LIST		26

SPECIFICATIONS

System	Compact disc digital audio system
Laser	Semiconductor laser ($\lambda = 780 \text{ nm}$) Emission duration: continuous
Laser output	Max. $44.6 \mu\text{W}^*$ * This output is the value measured at a distance of about 200 mm from the objective lens surface on the Optical Pick-up Block.
Signal to noise ratio	More than 90 dB
Dynamic range	More than 90 dB
Harmonic distortion	Less than 0.05% (at 1 kHz)
Channel separation	More than 90 dB
Output level	2 V (at 50 kilohms)
Load impedance	More than 10 kilohms
Outputs	DIGITAL OUT OPTICAL (optical output connector): wave length 660 nm, output level -18 dBm

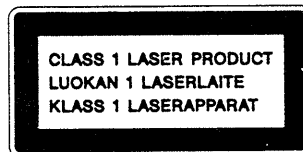

This appliance is classified as a CLASS 1 LASER product. The CLASS 1 LASER PRODUCT label is located on the rear exterior.

COMPACT DISC PLAYER
SONY®

LASER DIODE AND FOCUS SEARCH OPERATION CHECK

1. Make POWER switch on with no disc inserted and disc table closed.
2. Confirm that the following operation is performed while observing the objective lens.

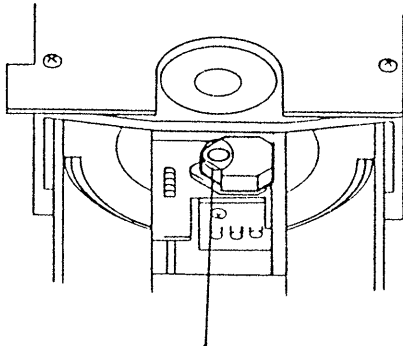

- ① Confirm that laser beam is spread.
- ② Up and down motion of the objective lens. (3 times)

HOW TO OPEN THE DISC TRAY WHEN POWER SWITCH TURNS OFF

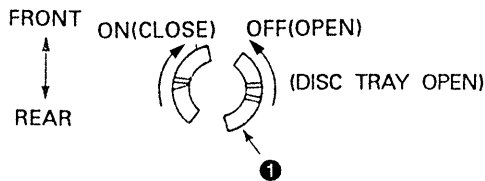
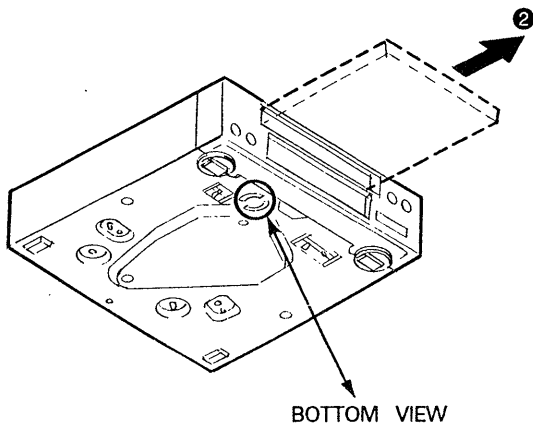

- (1) Insert to ① for tapering driver, etc., and turn in the direction of arrow OFF. (Disc tray open)
- (2) Tray as come out little of front panel, pull out in the direction of arrow ② by hand.

NOTES ON HANDLING THE OPTICAL PICK-UP BLOCK OR BASE UNIT

The laser diode in the optical pick-up block may suffer electrostatic break-down because of the potential difference generated by the charged electrostatic load, etc. on clothing and the human body. During repair, pay attention to electrostatic break-down and also use the procedure in the printed matter which is included in the repair parts.
The flexible board is easily damaged and should be handled with care.

NOTES ON LASER DIODE EMISSION CHECK

The laser beam on this model is concentrated so as to be focused on the disc reflective surface by the objective lens in the optical pick-up block. Therefore, when checking the laser diode emission, observe from more than 30 cm away from the objective lens.

SAFETY-RELATED COMPONENT WARNING!!

COMPONENTS IDENTIFIED BY MARK Δ OR DOTTED LINE WITH MARK Δ ON THE SCHEMATIC DIAGRAMS AND IN THE PARTS LIST ARE CRITICAL TO SAFE OPERATION. REPLACE THESE COMPONENTS WITH SONY PARTS WHOSE PART NUMBERS APPEAR AS SHOWN IN THIS MANUAL OR IN SUPPLEMENTS PUBLISHED BY SONY.

SECTION 1 GENERAL

LOCATION OF CONTROLS

This section is extracted from instruction manual.

CD Player Section

- 1 Disc tray
- 2 CHECK button
- 3 EDIT/TIME FADE button
- 4 CD operation buttons
 - △ : OPEN/CLOSE
 - ▷|| : Play/pause
 - ◀◀ ▶▶ : Manual search (when kept depressed)/Automatic Music Sensor (when pressed)
- 5 Display window

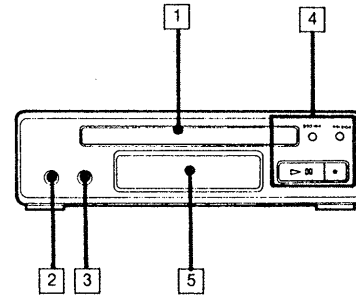

SECTION 2

ELECTRICAL BLOCK CHECKING

Note :

1. CD Block basically constructed to operate without adjustment. Therefore, check each item in order given.
2. Use YEDS-18 disc (3-702-101-01) unless otherwise indicated.
3. Use the oscilloscope with more than 10MΩ impedance.
4. Clean an object lens by an applicator with neutral detergent when the signal level is low than specified value with the following checks.

S Curve Check

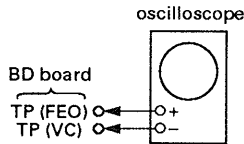

Procedure :

1. Connect oscilloscope to test point TP (FEO) on BD board.
2. Connect between test point TP (FES) and TP (VC) by lead wire.
3. Turned Power switch on and actuate the focus serch. (actuate the focus serch when disc table is moving in and out.)
4. Check the oscilloscope waveform (S curve) is symmetrical between A and B. And confirm peak to peak level within $3 \pm 1V_{p-p}$.

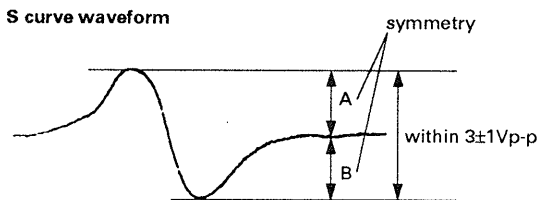

5. After check, remove the lead wire connected in step 2.

Note :

- Try to measure several times to make sure that the ratio of A : B or B : A is more than 10 : 7.
- Take sweep time as long as possible and light up the brightness to obtain best waveform.

RF Level Check

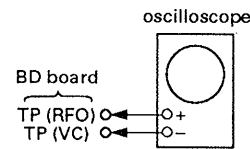

Procedure :

1. Connect oscilloscope to test point TP (RFO) on BD board.
2. Turn Power switch on.
3. Put disc (YEDS-18) in and playback.
4. Confirm that oscilloscope waveform is clear and check RF signal level is correct or not.

Note :

Clear RF signal waveform means that the shape "◇" can be clearly distinguished at the center of the waveform.

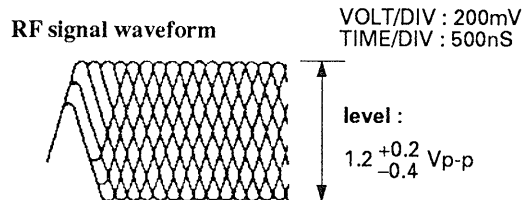

E-F Balance Check

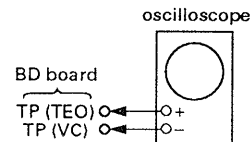

Procedure :

1. Connect test point TP (ADJ) to ground and TP (TES) to TP (VC) with lead wire.
2. Connect oscilloscope to test point TP (TEO) on BD board.
3. Turn Power switch on.
4. Put disc (YEDS-18) in and playback.
5. Confirm that the oscilloscope waveform is symmetrical on the top and bottom in relation to 0V, and check this level.

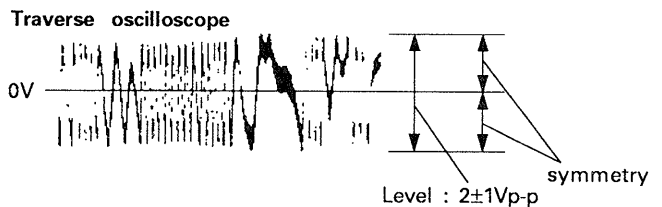

6. Remove the lead wire connected in step 1.

RF PLL FREE-RUN FREQUENCY CHECK

Procedure :

1. Connect frequency counter to test point (PCK) with lead wire.

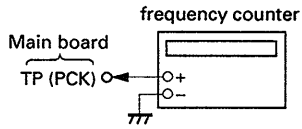

2. Turn Power switch on.
3. Confirm that reading on frequency counter is 4.3218MHz.

Focus/Tracking Gain

This gain has a margin, so even if it is slightly off.

There is no problem.

Therefore, do not perform, this adjustment.

Please note that it should be fixed to mechanical center position when you moved and do not know original position.

Checking for Location

[BD BOARD] - Conductor Side -

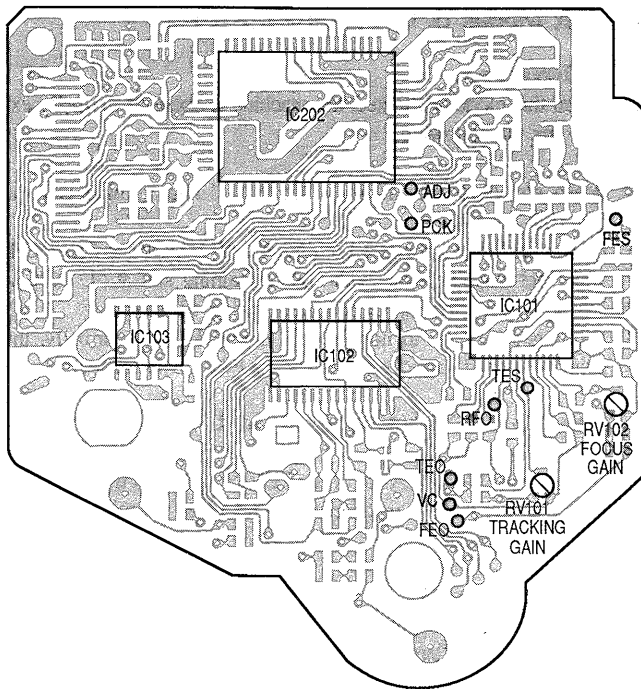

[TEST MODES]



1. Test mode of display micon (IC401)

Ground Pin ⑩ of IC401 to GND and turn ON the POWER switch, thus you can test the following 3 tests.

(1) All FL tube lamps

This mode is actuated immediately after turning ON the POWER switch.

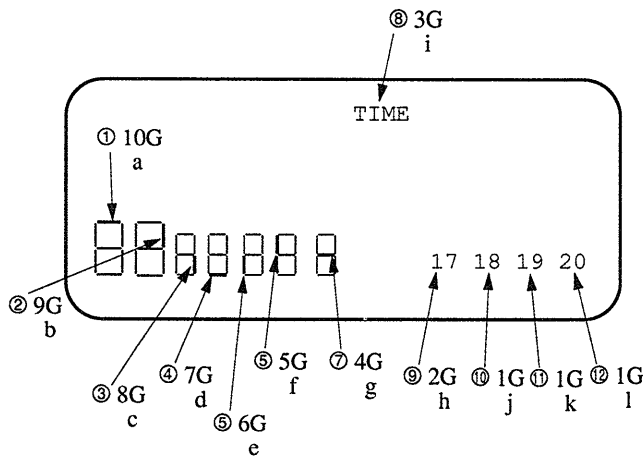

(2) FL tube segment check

This mode is actuated by pressing the  key in the state of (1). Every time the  key is pressed, the segments are indicated sequentially from the segment a. When the last 1 segment is displayed, keying in is no longer accepted while continuing the lighting-up state of the last segment. Conditions are normal provided all lamps light up in the following order.



(3) KEY check

This mode is effected by pressing the  key in the state of (1), while indicating "1." Every time a new key is pressed subsequently, the indicated number is incremented. Conditions are normal provided "7" is indicated when all types of keys are pressed. Even if a key is pressed again, it is not counted.

* To leave the mode (2) or (3), press the  and  keys in duplication, thereby the mode returning to all ON mode.

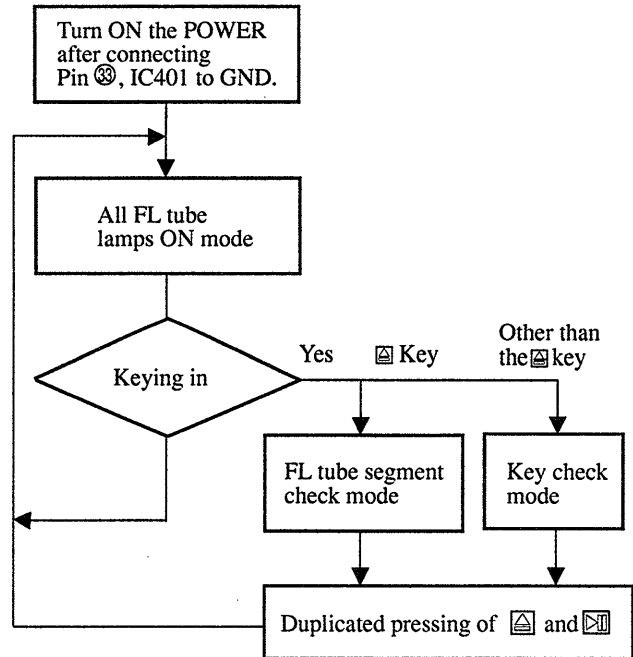

2. Test Modes of CD Syscon (IC202)

(1) ADJUST mode

When this mode is effected, the machine is operated normally except for the following.

- When pin ⑱, IC202 (ADJ) is set to "L" after turning ON the POWER switch:
 1. GFS is no longer monitored during PLAY, PAUSE or SEARCH, while not stopping even with GFS remaining still at "L" (NG).
 2. No high-speed feeding is activated during SEARCH.
 3. Focus gain is reset to normal gain during PLAY (normally, the gain is lowered to reduce noise when FOCUS is locked).
- When Pin ⑲, IC202 (AFADJ) is set to "L" after turning ON the POWER switch:
 1. Regardless of Pin ⑱ (ADJ) of the CLV-S fixed function, the CLV mode during PLAY becomes CLV-S (rough servo) only while Pin ⑲ remains "L".

(2) AFADJUST mode

In this mode, it is possible to check the interface between the display micon (IC401) and CD syscon (IC202).

- Set Pin ⑲, IC202 (AFADJ) to "L" before turning ON the POWER switch.
 1. Every time the  key is pressed after turning On the POWER switch, indication on the FL tube is switched correspondingly. Conditions are normal provided the indication repeats the 4 patterns including all lamp ON.

SECTION 3
DIAGRAMS

3-1. BLOCK DIAGRAM

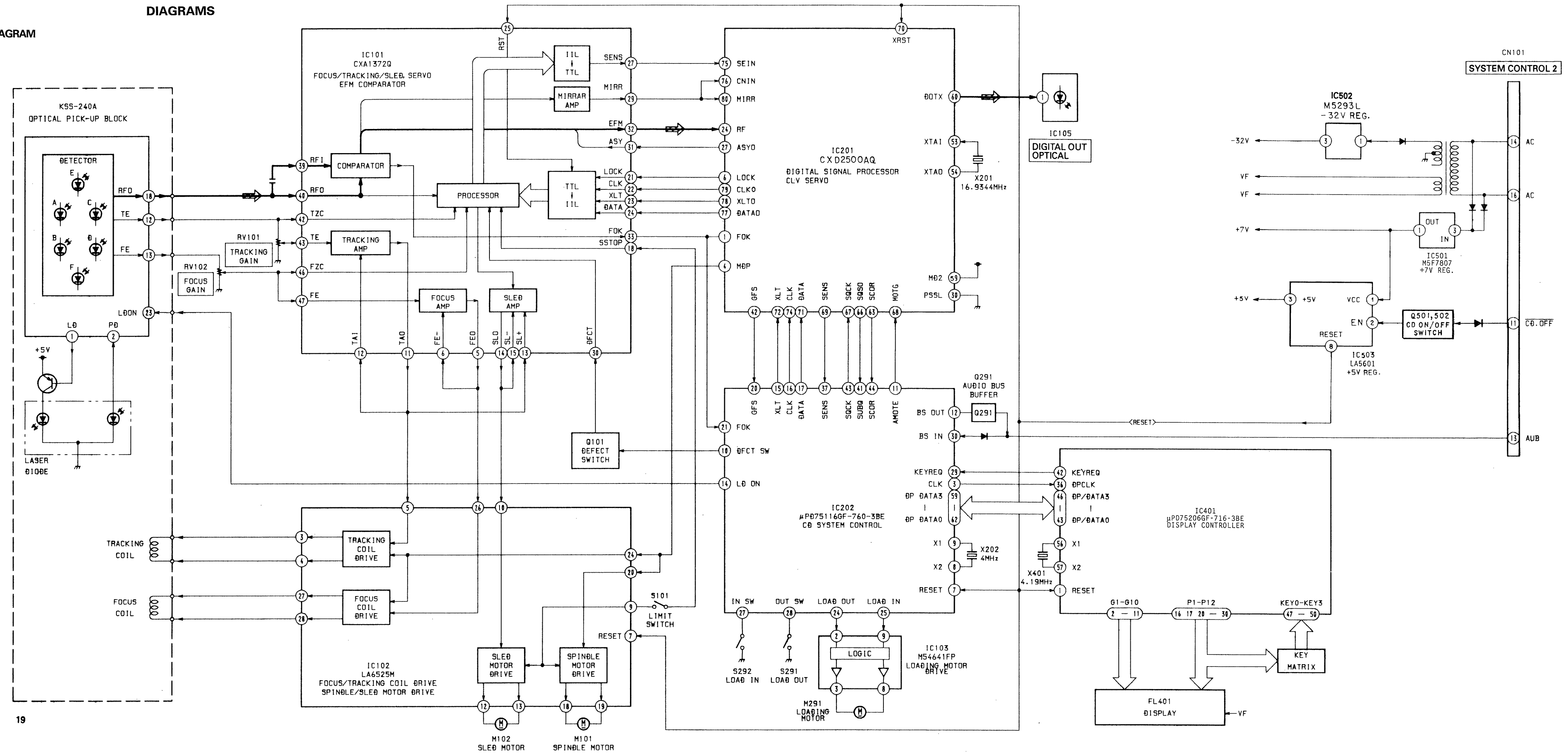

3-2. SEMICONDUCTOR LEAD LAYOUTS

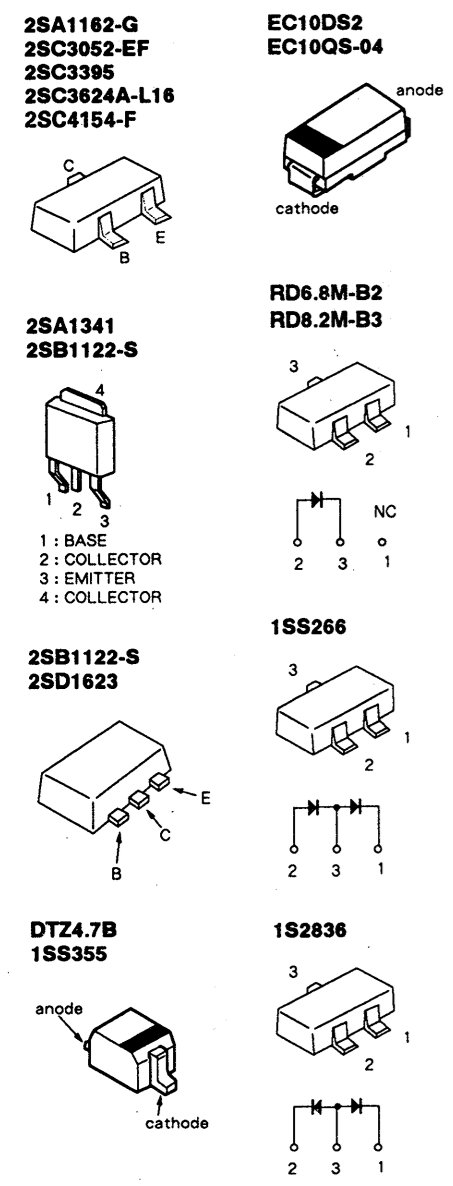

SEMICONDUCTOR LOCATION

Ref. No.	Location
IC101	D-1
IC101	G-7
IC102	B-5
IC102	H-6
IC103	B-2
IC103	H-5
IC105	B-3
IC201	G-11
IC202	F-6
IC301	G-12
IC302	F-12
IC304	F-1
IC401	D-12
Q101	C-1
Q101	F-7
Q102	B-1
Q103	B-1
Q201	F-12
Q201	G-13
Q301	G-1
Q302	E-1
Q303	G-1
Q304	E-1
Q305	E-1
Q306	E-1
D101	B-3
D101	H-5
D102	B-3
D103	B-3
D104	B-6
D106	B-6
D113	B-3
D131	B-3
D201	F-12
D301	E-1
D302	E-1
D305	E-1
D306	E-1
D401	D-14
D402	D-15
D403	D-11

Note:

- : indicated a lead wire mounted on the component side.
- : Part mounted on the conductor side.
- : Through hole.
- ▨ : Pattern from the side which enables seeing.
- ▩ : Pattern of the rear side.

3-3. PRINTED WIRING BOARDS

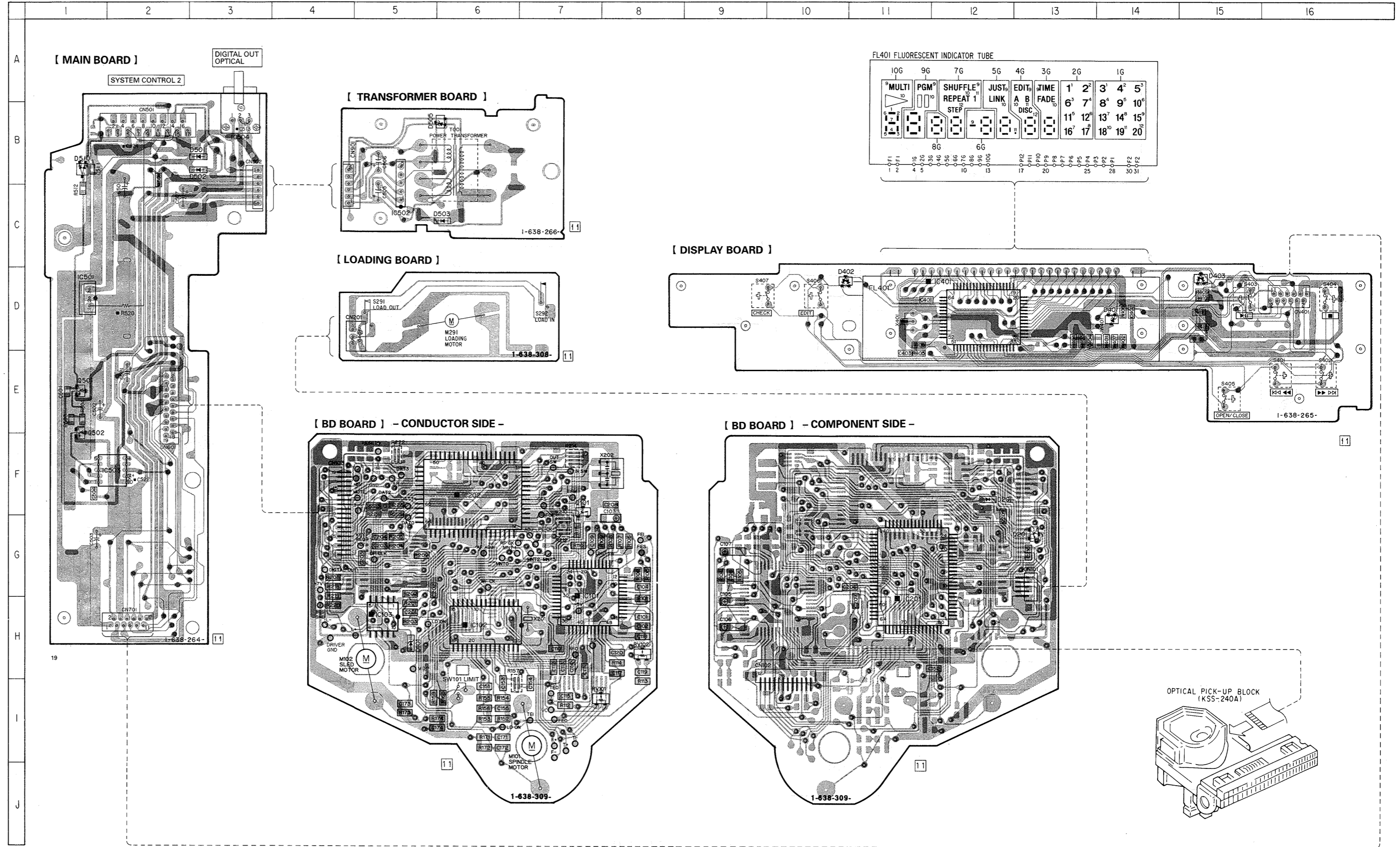

3-4. SCHEMATIC DIAGRAM - BD SECTION -

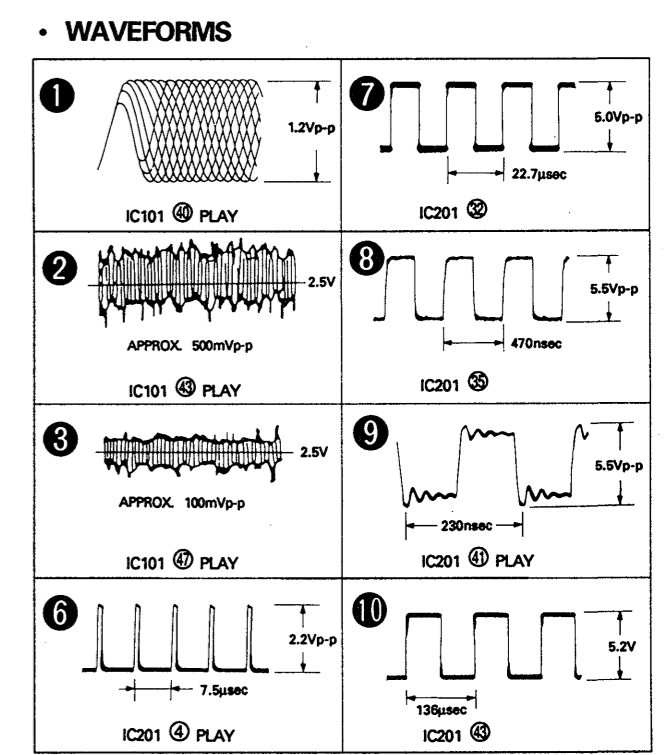
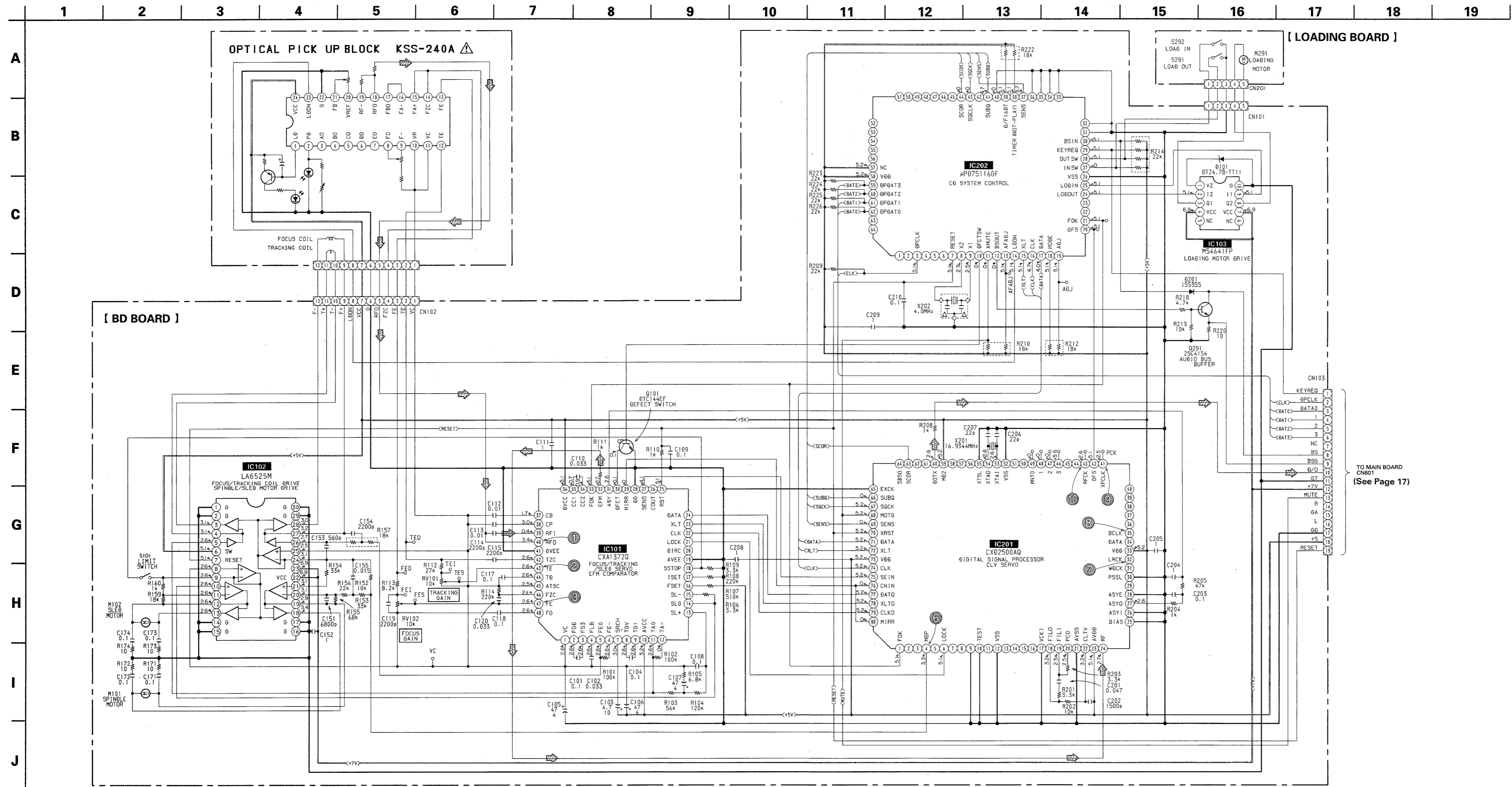

Note:

- All capacitors are in μF unless otherwise noted. pF: μF 50WV or less are not indicated except for electrolytics and tantalums.
- All resistors are in ohms, 1/4W or less unless otherwise noted.
- Δ : internal component.

The components identified by mark Δ or dotted line with mark Δ are critical for safety. Replace only with part number specified.

- : B + Line.
- : B - Line.
- : adjustment for repair.
- Voltagess are DC between measurement points and ground.
- no mark : PLAY
- Voltagess are taken with a VOM (input impedance 10M Ω). Voltage variations may be noted due to normal production tolerances.
- Waveforms are taken with an oscilloscope.
- Circled numbers refer to waveforms.
- Signal path
- ▬: CD

3-5. SCHEMATIC DIAGRAM - MAIN SECTION - See page 15 for note.

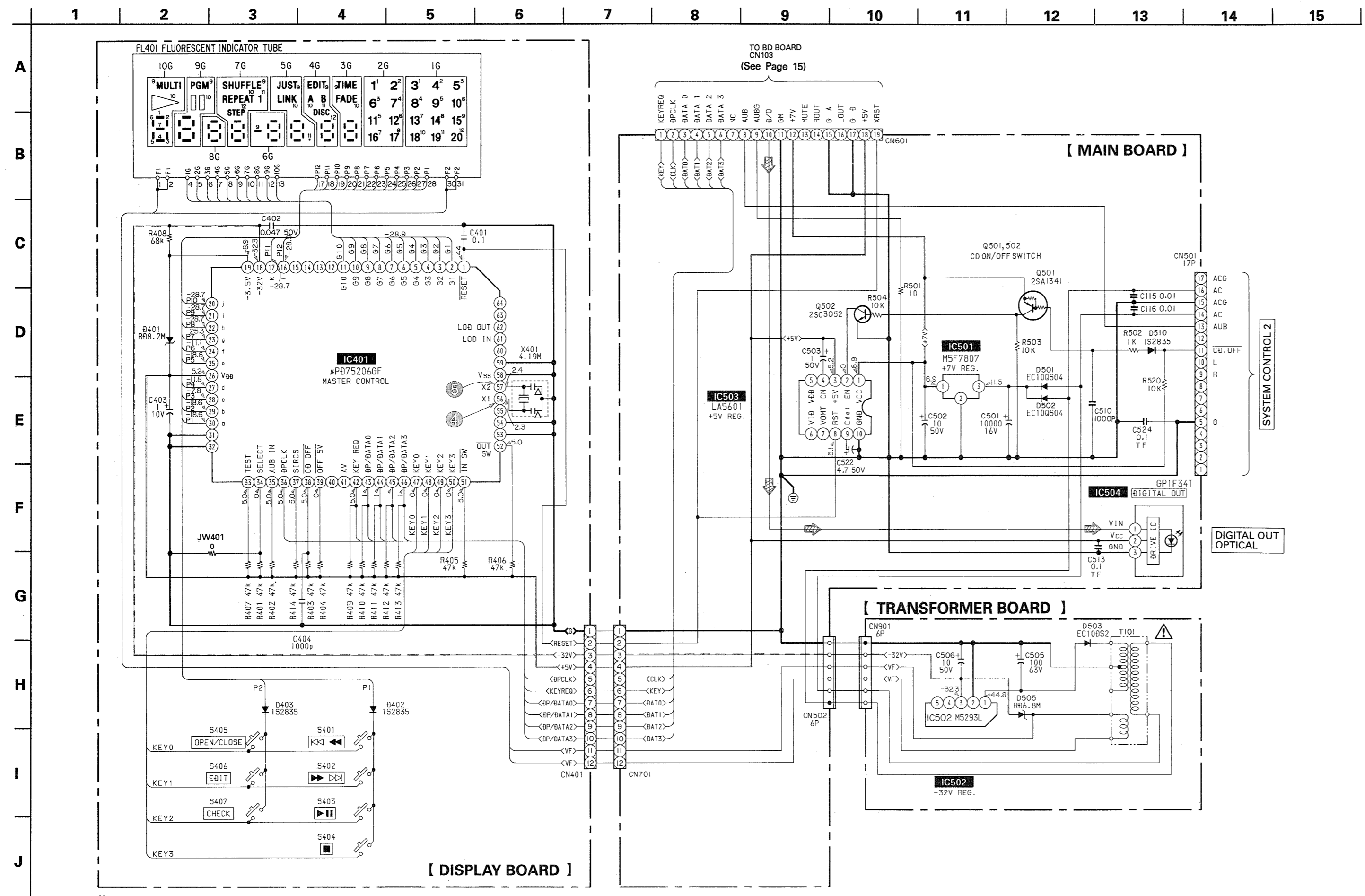

• WAVEFORMS

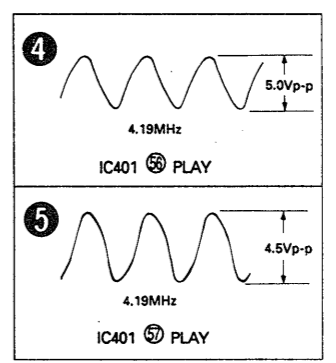

3-6. IC BLOCK DIAGRAMS

IC101 CXA1372Q

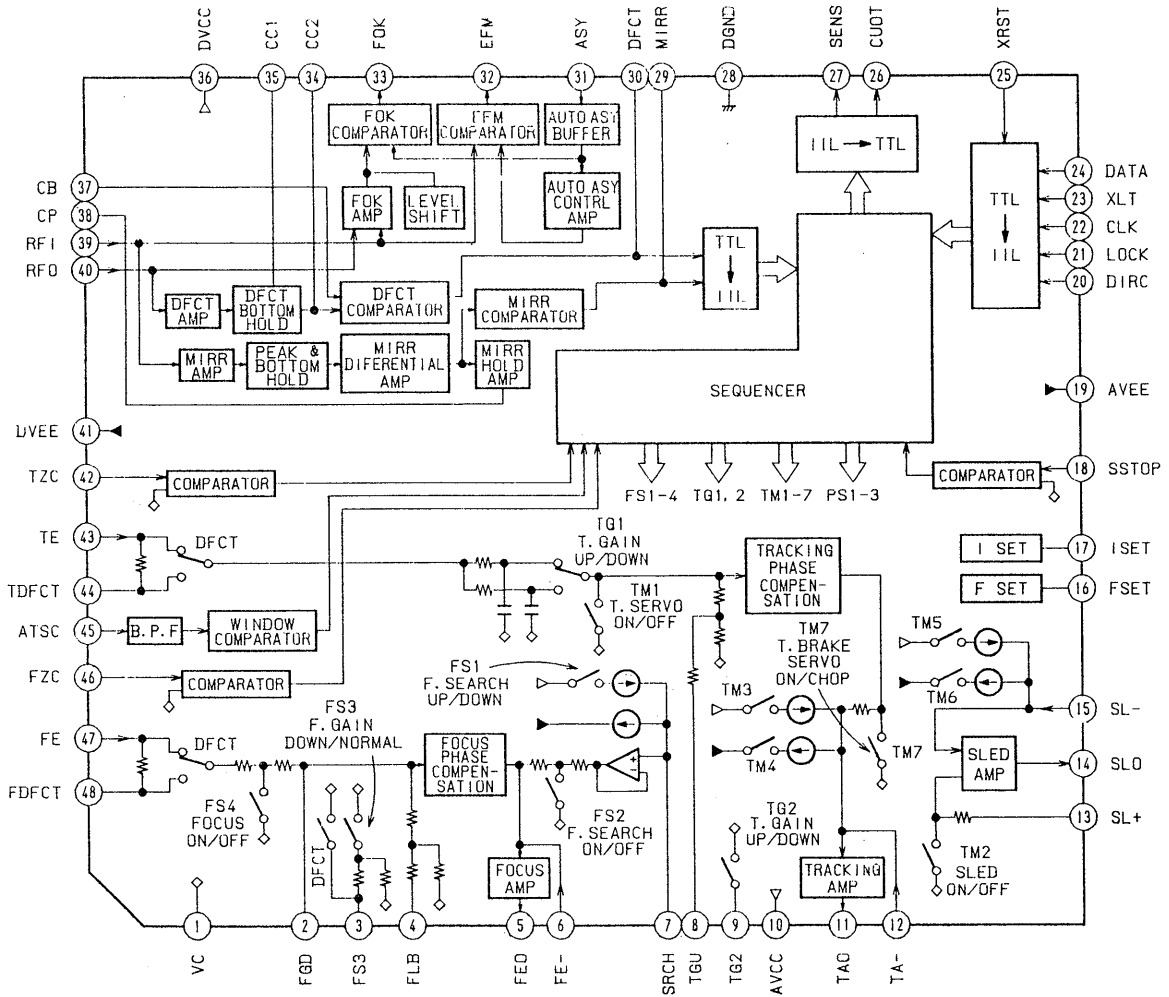

IC103 M54641FP

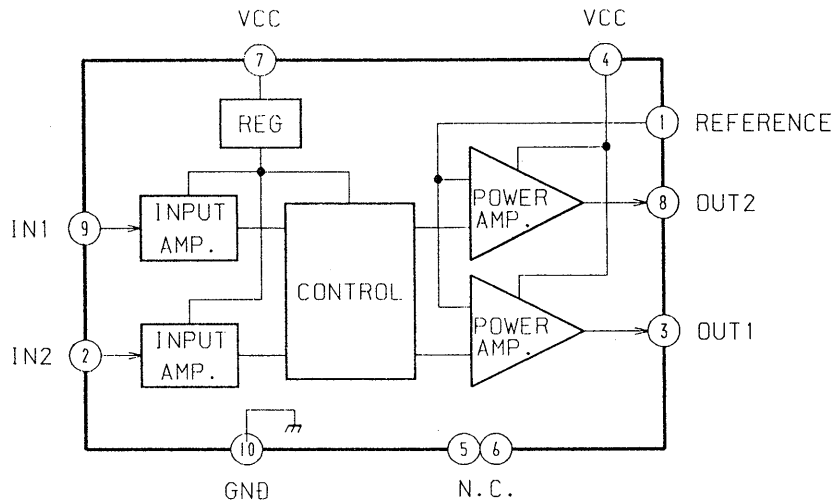

IC201 CXD2500AQ

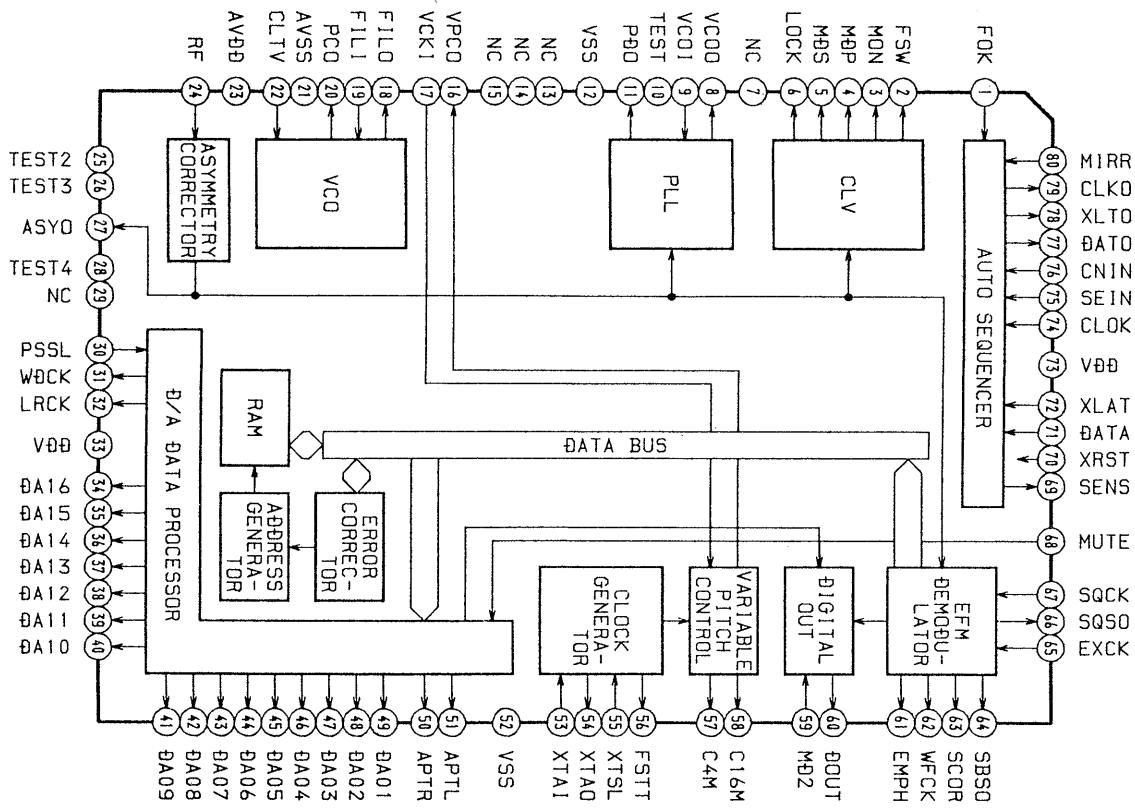

IC502 M5293L

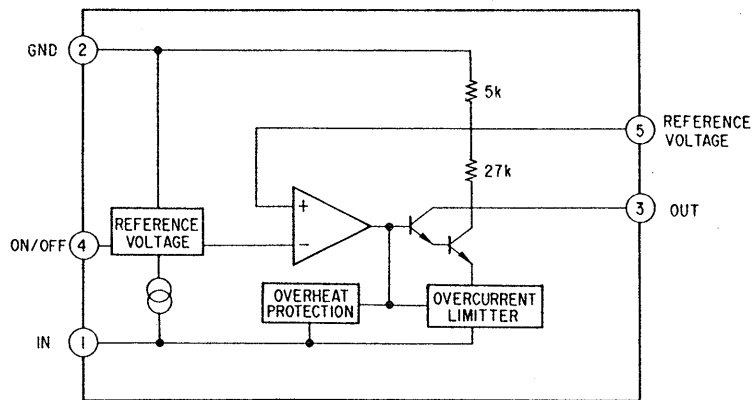

IC503 LA5601

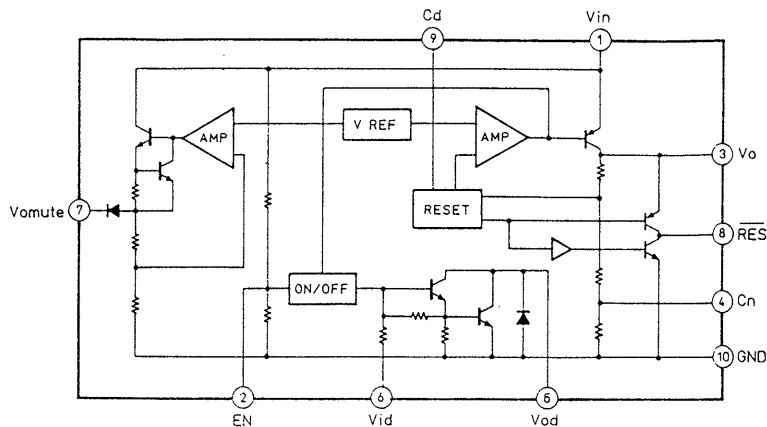

3-7. PIN FUNCTION OF IC202 AND IC401

• IC202 CD System Controller (μ PD75116GF-760-3BE)

Functions effected by the captioned controller include IC101 (RF signal processing servo) and IC201 (DSP digital filter) loading control in the CD unit, data exchange with IC401 (master controller), audio bus entry, etc.

Pin No.	Pin Name	I/O	Description
1-2	DPCLK	O	Not in use with the model (open).
3		O	Display data transfer clock output to IC401 (display micon)
4-6		O	Not in use with the model (open)
7	$\overline{\text{RESET}}$	I	System reset input. "L": Reset
8	X2	I	Clock input
9	X1	I	Clock input (4 MHz)
10	DPCF SW	O	DEFECT circuit ON/OFF switching output of IC101 (CXA1372Q). It is turned OFF ("H") to focus-search the DISK flaw detection circuit.
11	AMUTE	O	Muting control output. "H": Mute
12	BSOUT	O	Audio bus output
13	AFADJ	I	Test mode input. Various test operations are effected upon "L" after turning ON the POWER.
14	LDON	O	Optical pickup laser diode ON/OFF switching output. "H": ON
15	XLT	O	Serial data latch output to IC201 (CXD2500AQ)
16	CLK	O	Serial data transfer clock output to IC201 (CXD2500AQ)
17	DATA	O	Serial data output to IC201 (CXD2500AQ)
18	MODE	I	Not in use with the model (GND)
19	ADJ	I	Test mode input. Upon "L," GFS checking is disabled while continuously rotating the spindle no matter whether frame synch is issued during PLAY, PAUSE or SEARCH.
20	GFS	I	GFS signal input from IC201 (CXD2500AQ). "L": NG "H": OK
21	FOK	I	Focus OK signal input from IC101 (CXA1372Q). "H": OK
22 - 23		O	Not in use with the model (open)
24	LODOUT	O	Output to rotate M291 (loading motor) in the loading out direction. *1
25	LODIN	O	Output to rotate M291 (loading motor) in the loading in direction. *1
26	V _{ss}	-	Power terminal (GND)
27	$\overline{\text{IN SW}}$	I	S292 (Loading in switch) input
28	$\overline{\text{OUT SW}}$	I	S291 (Loading out switch) input
29	KEY REQ	I	Key data request input from IC401 (display micon)
30	BS IN	I	Audio bus input
31 - 36			Not in use with the model (GND)
37	$\overline{\text{SENS}}$	I	SENS input from IC101 (CXA1372Q) and IC201 (CXD2500AQ)
38	TIMER	I	Not in use with the model (pull up)
39	D/F 16BIT	I	IC201 (CXD2500AQ) digital filter mode setting input. It is fixed at 16 bit, 4Fs with the model (pull up).
40		I	Not in use with the model (GND)
41	SUBQ	I	Subcode Q data input from IC201 (CXD2500AQ)
42		O	Not in use with the model (open)
43	SQCLK	O	Subcode Q data reading clock output to IC201 (CXD2500AQ)
44	SCOR	I	Subcode synch S0 + S1 detection input from IC201 (CXD2500AQ)
45 - 56		O	Not in use with the model (open)
57	N.C.	I	Not in use with the model (+5V)
58	V _{DD}	-	Power terminal (+5V)
59 - 62	DPDATA3-0	I/O	Key data input and display data output with IC401 (display micon)
63 - 64		O	Not in use with the model (open)

*1 Loading motor control

	IN	OUT	BRAKE
LODOUT ②	L	H	H
LODIN ②	H	L	H

• IC401 Display controller (μ PD75206GF-716-3BE)

In charge of displaying the FL tube and keying in, it exchanges data with the IC202 (CD syscon) in 4-bit parallel mode.

Pin No.	Pin Name	I/O	Description
1	RESET	I	System reset input. "L": Reset
2 - 11	G1-10	O	Digital output to the FL tube
12 - 15		O	Not in use with the model (open)
16, 17	l, k	O	FL tube segment output
18	V _{LOAD}	-	Power supply for the FL tube controller (builtin) (-32V)
19	V _{PRE}	-	Power supply for the FL tube predriver (-3.5V)
20 - 25	j - e	O	FL tube segment output
26	V _{DD}	-	Power terminal (+5V)
27, 28	d, c	O	FL tube segment output
29, 30	b, a	O	FL tube segment, key scan output
31, 32		I	Not in use with the model (GND)
33	TEST	I	Test mode input. "L": Test mode
34	SELECT	I	Not in use with the model (pull up)
35	BSIN	I	Not in use with the model (pull up)
36	DPCLK	I	Display data transfer clock input from IC202 (CD syscon)
37, 38		I	Not in use with the model (pull up)
39		O	Not in use with the model (pull up)
40, 41		O	Not in use with the model (open)
42	KEY REQ	O	Key data request output to IC202 (CD syscon)
43 - 46	DPDATA0-3	I/O	Key data output and display data input with IC202 (CD syscon)
47 - 50	KEY0-3	I	Key data input
51, 52		I	Not in use with the model (pull up)
53, 54		I	Not in use with the model (GND)
55		O	Not in use with the model (open)
56	X1	I	System clock input (4.19 MHz)
57	X2	I	System clock input
58	V _{SS}	-	Power supply terminal (GND)
59		I	Not in use with the model (GND)
60 - 64		O	Not in use with the model (open)

SECTION 4 EXPLODED VIEWS

NOTE:

- -XX, -X mean standardized parts, so they may have some differences from the original one.
- Color Indication of Appearance Parts
Example:
KNOB,BALANCE(WHITE)...(RED)
 ↑ ↑
 Parts color Cabinet's color

- Items marked "*" are not stocked since they are seldom required for routine service. Some delay should be anticipated when ordering these items.
- The mechanical parts with no reference number in the exploded views are not supplied.
- Hardware(# mark) list is given in the last of this parts list.

The components identified by mark Δ or dotted line with mark Δ are critical for safety.
Replace only with part number specified.

When indicating parts by reference number, please include the board name.

(1) CHASSIS SECTION

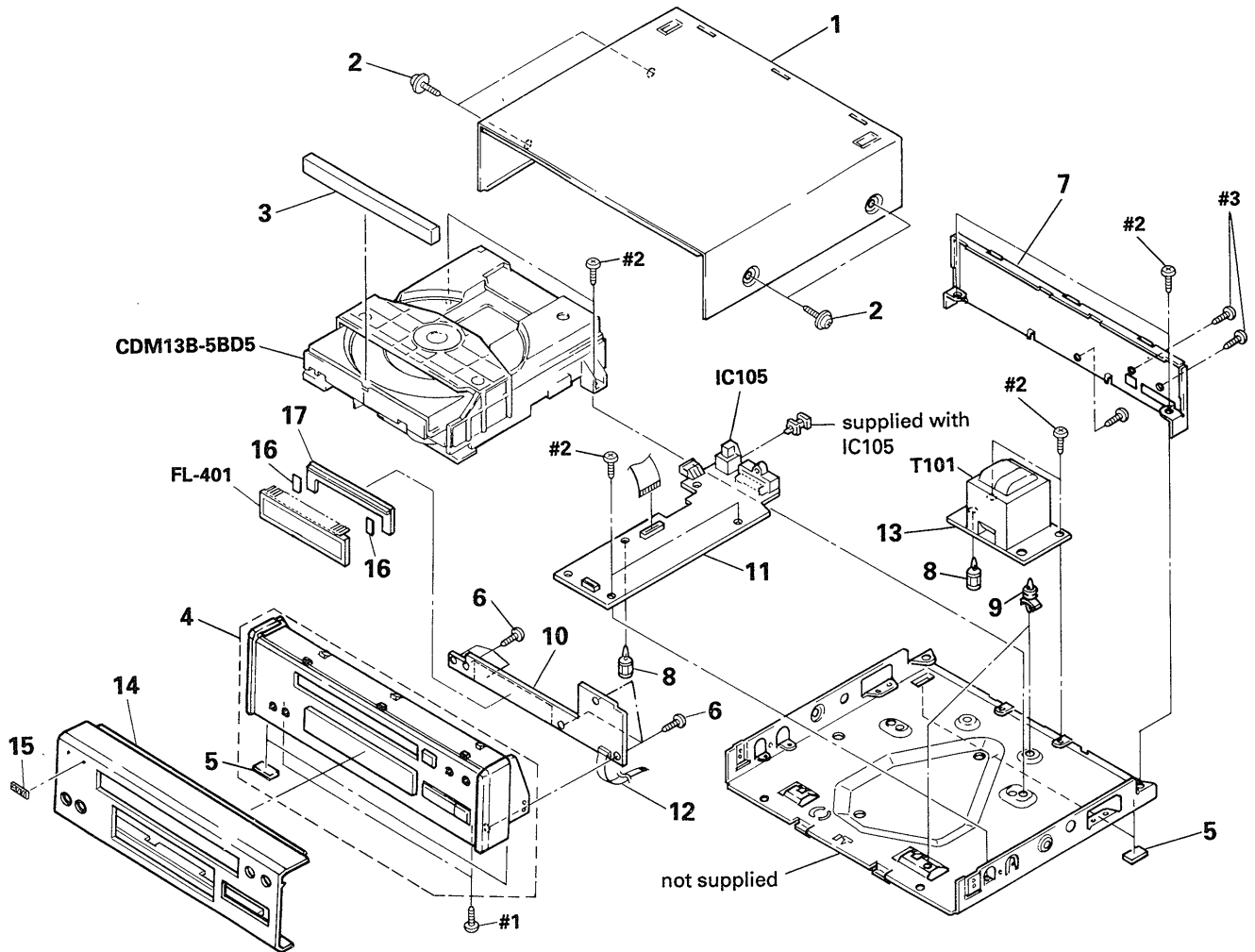

Ref. No.	Part No.	Description	Remarks	Ref. No.	Part No.	Description	Remarks
1	4-932-844-01	CASE		11	* 1-638-264-11	MAIN BOARD	
2	3-363-099-01	SCREW (CASE +3X8 TP2)		12	1-575-001-11	WIRE, FLAT TYPE (12 CORE)	
3	X-4941-527-1	LID (TRAY) ASSY		13	* 1-638-266-11	TRANSFORMER BOARD	
4	X-4941-525-1	PANEL ASSY, FRONT		14	4-944-445-01	PANEL, FRONT	
5	4-930-336-01	FOOT (FELT)		15	4-942-636-01	EMBLEM (NO. 3. 5), SONY	
6	4-928-635-01	SCREW, +BV (2.6X8) TAPPING		16	* 4-932-810-11	CUSHION (FL)	
7	* 4-943-175-11	PAENL, BACK		17	* 4-944-444-01	HOLDER (FL TUBE)	
8	* 3-669-610-00	SPACER		T101	Δ 1-450-341-11	TRANSFORMER, POWER	
9	* 4-924-098-11	HOLDER, PC BOARD					
10	* A-4617-802-A	DISPLAY BOARD, COMPLETE					

(2) CD MECHANISM SECTION (CDM13B-5BD5)

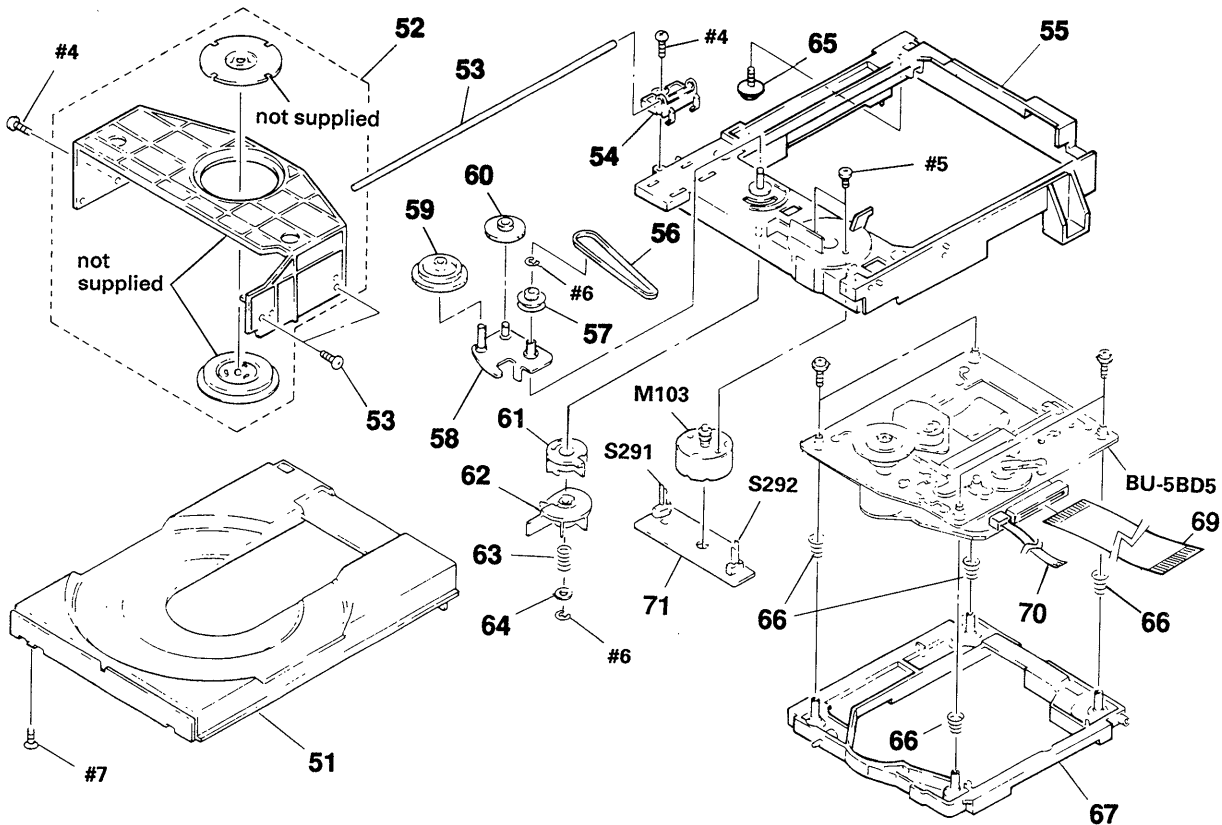

Ref. No.	Part No.	Description	Remarks	Ref. No.	Part No.	Description	Remarks
51	4-944-012-01	TABLE, DISC		62	4-929-729-01	CAM (B)	
52	A-4604-752-A	HOLDER (MG) ASSY		63	3-659-338-00	SPRING, COMPRESSION	
53	4-929-764-01	SHAFT (TABLE GUIDE)		64	4-927-654-01	WASHER (LIMITER)	
54	4-944-006-01	BEARING		65	* 4-917-583-21	BRACKET, YOKE	
55	X-4941-462-1	CHASSIS (MD) ASSY		66	4-917-541-01	SPRING (B)	
56	4-927-649-01	BELT		67	4-929-747-01	HOLDER (BU)	
57	4-929-724-01	PULLEY (B)		68	4-933-134-01	SCREW (+PTPWH M2. 6X6)	
58	X-4929-703-1	ARM ASSY, SWING		69	1-590-909-21	WIRE, FLAT TYPE (19 CORE)	
59	4-927-620-11	GEAR (P)		70	1-590-530-11	WIRE, FLAT TYPE	
60	4-927-628-01	GEAR (C)		71	* 1-638-308-11	LOADING BOARD	
61	4-929-727-01	CAM (A)		M103	A-4608-362-A	MOTOR (L) ASSY	

(3) OPTICAL PICK-UP BLOCK (BU-5BD5)

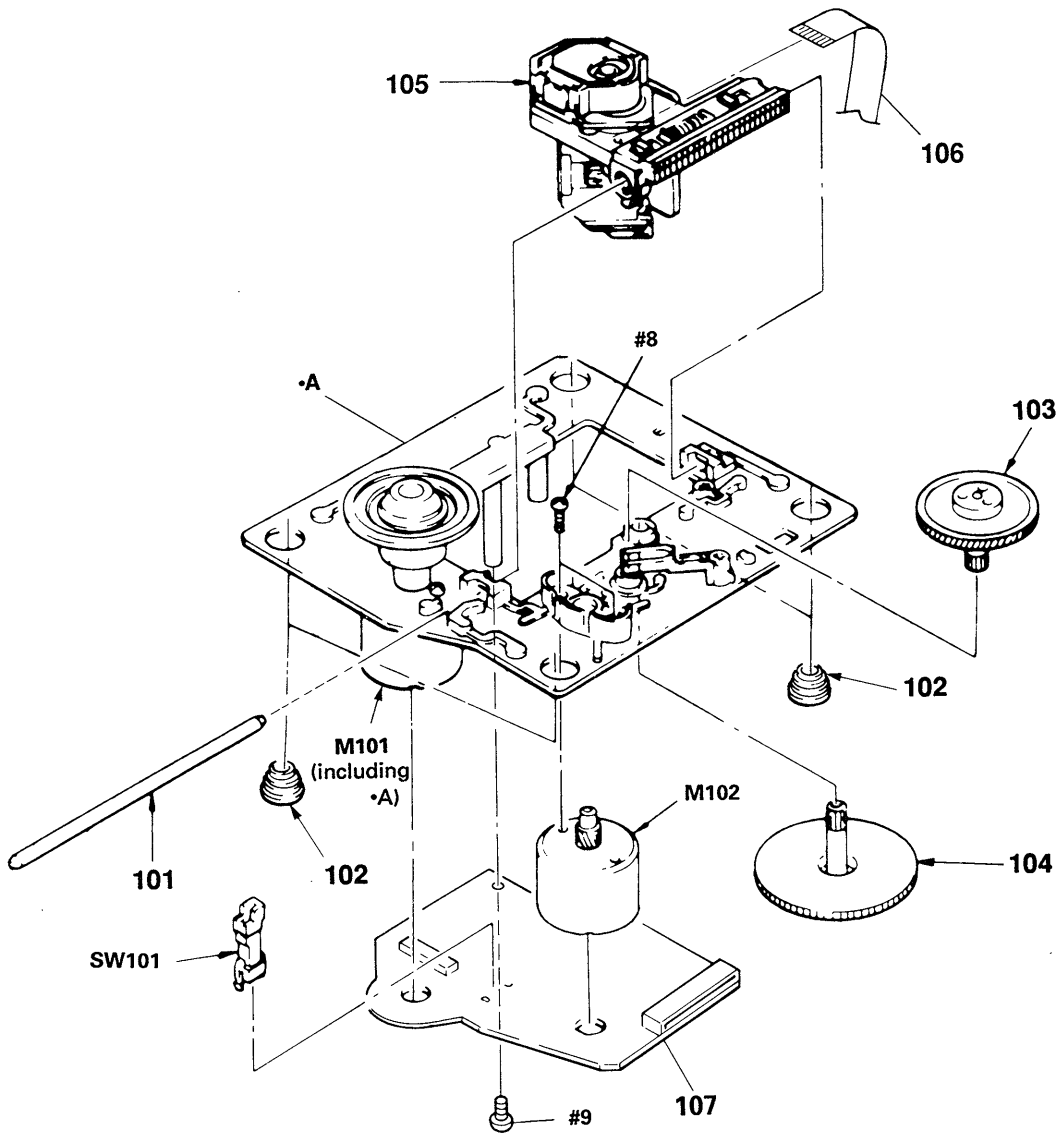

Ref. No.	Part No.	Description	Remarks
101	4-917-565-01	SHAFT, SLED	
102	4-933-126-01	INSULATOR (A)	
103	4-917-567-01	GEAR (M)	
104	4-917-564-01	GEAR (P), FLATNESS	
105	△ 8-848-144-11	DEVICE, OPTICAL KSS-240A	
106	1-575-001-11	WIRE, FLAT TYPE (12 CORE)	
107	* A-4617-762-A	BD BOARD, COMPLETE	
M101	X-4917-523-3	ASSY, MOTOR (SPINDLE)	
M102	X-4917-504-1	ASSY, MOTOR (SLED)	
SW101	1-572-085-11	SWITCH, LEAF (LIMIT)	

The components identified by mark △ or dotted line with mark △ are critical for safety. Replace only with part number specified.

SECTION 5

ELECTRICAL PARTS LIST

BD

NOTE:

The components identified by mark Δ or dotted line with mark Δ are critical for safety.
Replace only with part number specified.

When indicating parts by reference number, please include the board name.

- Due to standardization, replacements in the parts list may be different from the parts specified in the diagrams or the components used on the set.
- -XX, -X mean standardized parts, so they may have some difference from the original one.
- RESISTORS
All resistors are in ohms
METAL : Metal-film resistor
METAL OXIDE : Metal Oxide-film resistor
F : nonflammable
- Items marked "*" are not stocked since they are seldom required for routine service. Some delay should be anticipated when ordering these items.
- SEMICONDUCTORS
In each case, u: μ , for example :
uA...: μ A..., uPA...: μ PA...,
uPB...: μ PB..., uPC...: μ PC...,
uPD...: μ PD...
- CAPACITORS
uF : μ F
- COILS
uH : μ H

Ref. No.	Part No.	Description	Remarks	Ref. No.	Part No.	Description	Remarks
* A-4617-762-A BD BOARD, COMPLETE *****							
< CAPACITOR >							
C101	1-163-038-00	CERAMIC CHIP	0.1uF 25V	C205	1-164-346-11	CERAMIC CHIP	1uF 16V
C102	1-163-989-11	CERAMIC CHIP	0.033uF 10% 25V	C206	1-163-101-00	CERAMIC CHIP	22PF 5% 50V
C103	1-135-155-21	TANTALUM CHIP	4.7uF 10% 10V	C207	1-163-101-00	CERAMIC CHIP	22PF 5% 50V
C104	1-163-038-00	CERAMIC CHIP	0.1uF 25V	C208	1-164-346-11	CERAMIC CHIP	1uF 16V
C105	1-126-607-11	ELECT CHIP	47uF 20% 4V	C209	1-164-346-11	CERAMIC CHIP	1uF 16V
C106	1-126-607-11	ELECT CHIP	47uF 20% 4V	C210	1-163-038-00	CERAMIC CHIP	0.1uF 25V
C107	1-126-607-11	ELECT CHIP	47uF 20% 4V	< CONNECTOR >			
C108	1-163-038-00	CERAMIC CHIP	0.1uF 25V	CN101	1-580-858-11	SOCKET, CONNECTOR (SMT)	5P
C109	1-163-038-00	CERAMIC CHIP	0.1uF 25V	CN102	1-580-866-11	SOCKET, CONNECTOR (SMT)	12P
C110	1-163-989-11	CERAMIC CHIP	0.033uF 10% 25V	CN103	1-580-872-41	SOCKET, CONNECTOR (SMT)	19P
C111	1-164-346-11	CERAMIC CHIP	1uF 16V	< DIODE >			
C112	1-164-232-11	CERAMIC CHIP	0.01uF 50V	D101	8-719-976-96	DIODE	DTZ4.7B
C113	1-164-232-11	CERAMIC CHIP	0.01uF 50V	D201	8-719-988-62	DIODE	1SS355
C114	1-164-695-11	CERAMIC CHIP	0.0022uF 5% 50V	< IC >			
C115	1-164-695-11	CERAMIC CHIP	0.0022uF 5% 50V	IC101	8-752-050-82	IC	CXA1372Q
C117	1-163-038-00	CERAMIC CHIP	0.1uF 25V	IC102	8-759-823-48	IC	LA6525M
C118	1-163-038-00	CERAMIC CHIP	0.1uF 25V	IC103	8-759-636-20	IC	M54641FP
C119	1-164-695-11	CERAMIC CHIP	0.0022uF 5% 50V	IC201	8-752-337-26	IC	CXD2500AQ
C120	1-163-989-11	CERAMIC CHIP	0.033uF 10% 25V	IC202	8-759-153-16	IC	uPD75116GF-760-3BE
C151	1-163-019-00	CERAMIC CHIP	0.0068uF 10% 50V	< TRANSISTOR >			
C152	1-164-346-11	CERAMIC CHIP	1uF 16V	Q101	8-729-805-45	TRANSISTOR	2SC3395
C153	1-163-135-00	CERAMIC CHIP	560PF 5% 50V	Q201	8-729-602-21	TRANSISTOR	2SC4154-F
C154	1-164-695-11	CERAMIC CHIP	0.0022uF 5% 50V	< RESISTOR >			
C155	1-163-023-00	CERAMIC CHIP	0.015uF 5% 50V	R101	1-216-097-00	METAL CHIP	100K 5% 1/10W
C171	1-163-038-00	CERAMIC CHIP	0.1uF 25V	R102	1-216-097-00	METAL CHIP	100K 5% 1/10W
C172	1-163-038-00	CERAMIC CHIP	0.1uF 25V	R103	1-216-091-00	METAL CHIP	56K 5% 1/10W
C173	1-163-038-00	CERAMIC CHIP	0.1uF 25V	R104	1-216-099-00	METAL CHIP	120K 5% 1/10W
C174	1-163-038-00	CERAMIC CHIP	0.1uF 25V	R105	1-216-069-00	METAL CHIP	6.8K 5% 1/10W
C201	1-163-809-11	CERAMIC CHIP	0.047uF 10% 25V	R106	1-216-061-00	METAL CHIP	3.3K 5% 1/10W
C202	1-163-145-00	CERAMIC CHIP	0.0015uF 5% 50V	R107	1-216-114-00	METAL GLAZE	510K 5% 1/10W
C203	1-163-038-00	CERAMIC CHIP	0.1uF 25V	R108	1-216-105-00	METAL CHIP	220K 5% 1/10W
C204	1-164-346-11	CERAMIC CHIP	1uF 16V	R109	1-216-061-00	METAL CHIP	3.3K 5% 1/10W
				R110	1-216-049-00	METAL CHIP	1K 5% 1/10W

BD **DISPLAY** **MAIN** **TRANSFORMER**

Ref. No.	Part No.	Description	Remarks	Ref. No.	Part No.	Description	Remarks
R111	1-216-049-00	METAL CHIP	1K 5% 1/10W				
R112	1-216-083-00	METAL CHIP	27K 5% 1/10W				
R113	1-216-071-00	METAL CHIP	8.2K 5% 1/10W				
R114	1-216-105-00	METAL CHIP	220K 5% 1/10W				
R152	1-216-073-00	METAL CHIP	10K 5% 1/10W				
R153	1-216-085-00	METAL CHIP	33K 5% 1/10W				
R154	1-216-085-00	METAL CHIP	33K 5% 1/10W				
R155	1-216-093-00	METAL CHIP	68K 5% 1/10W				
R156	1-216-081-00	METAL CHIP	22K 5% 1/10W				
R157	1-236-427-11	NETWORK, RES	18K				
R159	1-216-079-00	METAL CHIP	18K 5% 1/10W				
R160	1-216-049-00	METAL CHIP	1K 5% 1/10W				
R171	1-216-001-00	METAL CHIP	10 5% 1/10W				
R172	1-216-001-00	METAL CHIP	10 5% 1/10W				
R173	1-216-001-00	METAL CHIP	10 5% 1/10W				
R174	1-216-001-00	METAL CHIP	10 5% 1/10W				
R201	1-216-061-00	METAL CHIP	3.3K 5% 1/10W				
R202	1-216-073-00	METAL CHIP	10K 5% 1/10W				
R203	1-216-061-00	METAL CHIP	3.3K 5% 1/10W				
R204	1-216-049-00	METAL CHIP	1K 5% 1/10W				
R205	1-216-089-00	METAL CHIP	47K 5% 1/10W				
R208	1-216-049-00	METAL CHIP	1K 5% 1/10W				
R209	1-216-081-00	METAL CHIP	22K 5% 1/10W				
R210	1-236-427-11	NETWORK, RES	18K				
R212	1-236-427-11	NETWORK, RES	18K				
R214	1-239-039-11	NETWORK, RES	22K				
R218	1-216-065-00	METAL CHIP	4.7K 5% 1/10W				
R219	1-216-073-00	METAL CHIP	10K 5% 1/10W				
R220	1-216-001-00	METAL CHIP	10 5% 1/10W				
R222	1-236-427-11	NETWORK, RES	18K				
R223	1-216-081-00	METAL CHIP	22K 5% 1/10W				
R224	1-216-081-00	METAL CHIP	22K 5% 1/10W				
R225	1-216-081-00	METAL CHIP	22K 5% 1/10W				
R226	1-216-081-00	METAL CHIP	22K 5% 1/10W				
		(VARIABLE RESISTOR)					
RV101	1-241-395-11	RES, ADJ, METAL GLAZE	10K				
RV102	1-241-395-11	RES, ADJ, METAL GLAZE	10K				
		(SWITCH)					
SW101	1-572-085-11	SWITCH, LEAF (LIMIT)					
		(CRYSTAL)					
X201	1-579-280-11	VIBRATOR, CRYSTAL (16.9344MHz)					
X202	1-579-216-11	VIBRATOR, CERAMIC (4MHz)					

		(CAPACITOR)					
				C115	1-164-232-11	CERAMIC CHIP 0.01uF	50V
				C116	1-164-232-11	CERAMIC CHIP 0.01uF	50V
				C401	1-163-038-00	CERAMIC CHIP 0.1uF	25V
				C402	1-163-035-00	CERAMIC CHIP 0.047uF	50V
				C403	1-164-346-11	CERAMIC CHIP 1uF	16V
				C404	1-163-009-11	CERAMIC CHIP 0.001uF	10% 50V
				C501	1-126-939-11	ELECT 10000uF	20% 16V
				C502	1-124-907-11	ELECT 10uF	20% 50V
				C503	1-124-903-11	ELECT 1uF	20% 50V
				C504	1-164-346-11	CERAMIC CHIP 1uF	16V
				C505	1-126-063-11	ELECT 100uF	20% 63V
				C506	1-124-907-11	ELECT 10uF	20% 50V
				C507	1-124-903-11	ELECT 1uF	20% 50V
				C510	1-163-009-11	CERAMIC CHIP 0.001uF	10% 50V
				C513	1-136-165-00	FILM 0.1uF	5% 50V
				C521	1-126-176-11	ELECT 220uF	20% 10V
				C522	1-124-927-11	ELECT 4.7uF	20% 50V
				C524	1-136-165-00	FILM 0.1uF	5% 50V
		(CONNECTOR)					
				CN401	* 1-573-098-11	HOUSING, CONNECTOR 12P	
				CN501	* 1-569-624-11	SOCKET, CONNECTOR 17P	
				CN502	1-568-662-11	CONNECTOR, BOARD TO BOARD 6P	
				CN601	* 1-573-149-11	SOCKET, CONNECTOR 19P	
				CN901	1-568-668-11	CONNECTOR, BOARD TO BOARD 6P	
		(DIODE)					
				D401	8-719-106-36	DIODE RD8.2M-B3	
				D402	8-719-104-34	DIODE 1S2836	
				D403	8-719-104-34	DIODE 1S2836	
				D501	8-719-210-39	DIODE EC10QS-04	
				D502	8-719-210-39	DIODE EC10QS-04	
				D503	8-719-210-33	DIODE EC10DS2	
				D505	8-719-106-17	DIODE RD6.8M-B2	
				D510	8-719-104-34	DIODE 1S2836	
		(FLUORESCENT TUBE)					
				FL401	1-519-652-11	INDICATOR TUBE, FLUORESCENT	

When indicating parts by reference number, please include the board name.

DISPLAY

MAIN

TRANSFORMER

LOADING

Ref. No.	Part No.	Description	Remarks
< IC >			
IC401	8-759-154-14	IC uPD75206GF-716-3BE	
IC501	8-759-604-86	IC M5F7807L	
IC502	8-759-633-42	IC M5293L	
IC503	8-759-821-93	IC LA5601	
IC504	8-749-922-39	IC GP1F34T	
< JUMPER >			
JW401	1-216-295-00	METAL CHIP 0	5% 1/10W
< TRANSISTOR >			
Q501	8-729-805-69	TRANSISTOR 2SA1341	
Q502	8-729-620-06	TRANSISTOR 2SC3052EF	
< RESISTOR >			
R401	1-216-089-00	METAL CHIP 47K	5% 1/10W
R402	1-216-089-00	METAL CHIP 47K	5% 1/10W
R403	1-216-089-00	METAL CHIP 47K	5% 1/10W
R404	1-216-089-00	METAL CHIP 47K	5% 1/10W
R405	1-216-089-00	METAL CHIP 47K	5% 1/10W
R406	1-216-089-00	METAL CHIP 47K	5% 1/10W
R407	1-216-089-00	METAL CHIP 47K	5% 1/10W
R408	1-216-093-00	METAL CHIP 68K	5% 1/10W
R409	1-216-089-00	METAL CHIP 47K	5% 1/10W
R410	1-216-089-00	METAL CHIP 47K	5% 1/10W
R411	1-216-089-00	METAL CHIP 47K	5% 1/10W
R412	1-216-089-00	METAL CHIP 47K	5% 1/10W
R413	1-216-089-00	METAL CHIP 47K	5% 1/10W
R501	1-216-001-00	METAL CHIP 10	5% 1/10W
R502	1-216-049-00	METAL CHIP 1K	5% 1/10W
R503	1-216-073-00	METAL CHIP 10K	5% 1/10W
R504	1-216-073-00	METAL CHIP 10K	5% 1/10W
R520	1-249-429-11	CARBON 10K	5% 1/4W
< SWITCH >			
S401	1-572-184-11	SWITCH, KEYBOARD (◀◀ ◀◀)	
S402	1-572-184-11	SWITCH, KEYBOARD (▶▶ ▶▶)	
S403	1-572-184-11	SWITCH, KEYBOARD (▶▶▶)	
S404	1-572-184-11	SWITCH, KEYBOARD (■)	
S405	1-572-184-11	SWITCH, KEYBOARD (OPEN/CLOSE △)	
S406	1-572-184-11	SWITCH, KEYBOARD (EDIT)	
S407	1-572-184-11	SWITCH, KEYBOARD (CHECK)	
< TRANSFORMER >			
T101	△ 1-450-341-11	TRANSFORMER, POWER	
< CRYSTAL >			
X401	1-577-359-21	VIBRATOR, CERAMIC (4.19MHz)	

Ref. No.	Part No.	Description	Remarks

	* 1-638-308-11	LOADING BOARD	

< CONNECTOR >			
CN201	1-580-918-11	HOUSING, CONNECTOR 5P	
< SWITCH >			
S291	1-571-924-11	SWITCH, LEAF (LOAD OUT)	
S292	1-571-924-11	SWITCH, LEAF (LOAD IN)	

MISCELLANEOUS			

12	1-575-001-11	WIRE, FLAT TYPE (12 CORE)	
69	1-590-909-21	WIRE, FLAT TYPE (19 CORE)	
70	1-590-530-11	WIRE, FLAT TYPE	
105	△ 8-848-144-11	DEVICE, OPTICAL KSS-240A	
106	1-575-001-11	WIRE, FLAT TYPE (12 CORE)	
M101	X-4917-523-3	ASSY, MOTOR (SPINDLE)	
M102	X-4917-504-1	ASSY, MOTOR (SLED)	
M291	A-4608-362-A	MOTOR (L) ASSY (LOADING)	

ACCESSORY & PACKING MATERIAL			

	4-920-941-01	SHEET (B), PROTECTION	
	* 4-941-548-01	LABEL, CLASS 1	
	* 4-945-079-01	CUSHION	

HARDWARE LIST			

# 1	7-682-547-09	SCREW +BVTT 3X6 (S)	
# 2	7-682-547-04	SCREW +BVTT 3X6 (S)	
# 3	7-685-647-79	SCREW +BVTP 3X10 TYPE2 N-S	
# 4	7-685-646-79	SCREW +BVTP 3X8 TYPE2 N-S	
# 5	7-621-775-10	SCREW +B 2. 6X4	
# 6	7-624-105-04	STOP RING 2.3, TYPE -E	
# 7	7-685-234-19	SCREW +KTP 2. 6X8 TYPE2NON-SLIT	
# 8	7-621-255-15	SCREW +P 2X3	
# 9	7-685-134-19	SCREW +BTP 2. 6X8 TYPE2 N-S	
#10	7-682-548-04	SCREW +BVTT 3X8 (S)	

The components identified by mark △ or dotted line with mark △ are critical for safety.
Replace only with part number specified.

When indicating parts by reference number, please include the board name.