

# CDP-M18/M19

## SERVICE MANUAL

Canadian Model  
CDP-M18

US Model  
Canadian Model  
E Model  
CDP-M19

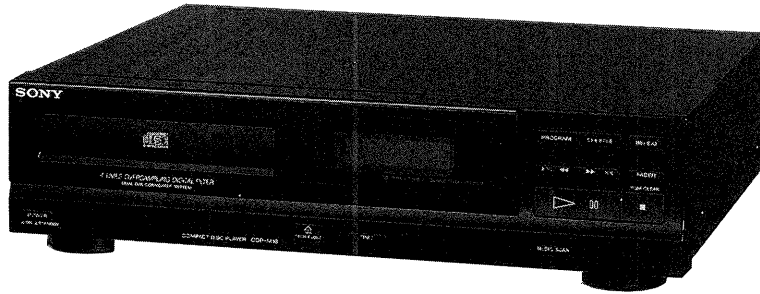

Photo : CDP-M18

Model Name Using Similar Mechanism	CDP-190/390
CD Mechanism Name	CDM14-5BD1
Base Unit Name	BU-5BD1

### SPECIFICATIONS

#### Compact disc player

Frequency response	2Hz-20kHz $\pm 1\frac{1}{2}$ dB
Signal to noise ratio	More than 93dB
Dynamic range	More than 90dB
Harmonic distortion	Less than 0.05%
Channel separation	More than 90dB

Power consumption	10W
Dimensions	355×95×300mm (w/h/d) (approx, including projections) (14×3 $\frac{3}{4}$ ×11 $\frac{1}{8}$ inches)
Weight (approx)	2.8kg (6 lbs 3 oz)

Design and specifications subject to change without notice.

#### Outputs

LINE OUT (phono jacks) Output level 2V (at 50 kilohms)  
Load impedance over 10 kilohms

PHONES (CDP-M19) Output level max. 14mW  
(stereo phone jack) Load impedance 32 ohms

#### General

Power requirements US, Canadian model :  
120V AC, 60Hz  
E, Saudi Arabia, Australian model :  
110, 120, 220 or 240VAC  
adjustable, 50/60Hz

COMPACT DISC PLAYER  
**SONY**®



TABLE OF CONTENTS

Section	Title	Page
<b>SECTION 1. GENERAL</b>		
1-1.	Location and Function of Controls.....	2
<b>SECTION 2. SERVICING NOTES</b> .....3		
<b>SECTION 3. ELECTRICAL ADJUSTMENTS</b> .....4		
<b>SECTION 4. DIAGRAMS</b>		
4-1.	Printed Wiring Boards.....	6
4-2.	Schematic Diagram.....	9
4-3.	IC Block Diagram.....	12
<b>SECTION 5. EXPLODED VIEWS</b> ..... 14		
<b>SECTION 6. ELECTRICAL PARTS LIST</b> ..... 18		

HOW TO OPEN THE DISC TRAY WHEN POWER SWITCH TURNS OFF

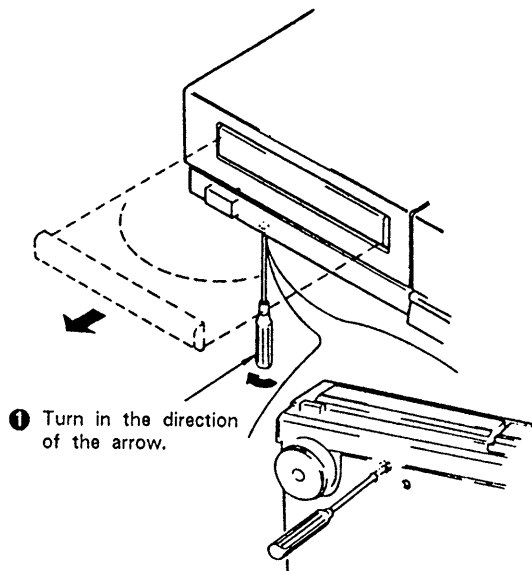

Caution : When you work, keep the set horizontal.

SECTION 1  
GENERAL

1-1. LOCATION AND FUNCTION OF CONTROLS

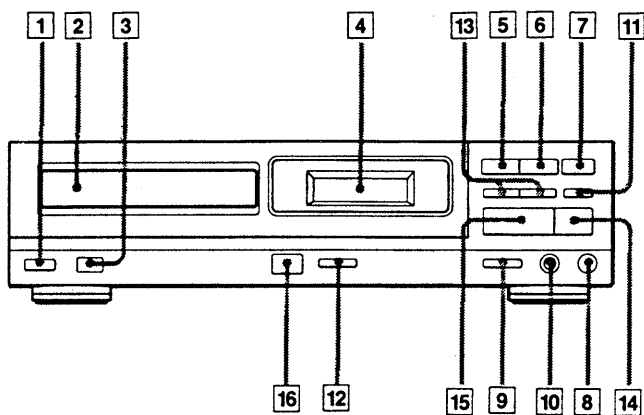

- 1 POWER switch
- 2 Disc tray
- 3 Remote sensor
- 4 Display window
- 5 PROGRAM button
- 6 SHUFFLE button
- 7 REPEAT button
- 8 (headphone) LEVEL control (CDP-M19)
- 9 MUSIC SCAN button
- 10 PHONES jack (CDP-M19)
- 11 FADER button
- 12 TIME button
- 13 ◀▶▶▶ (AMS\*/RMS\*\*)/▶▶▶▶ (manual search) buttons
- 14 ■ (stop)/PGM (program) CLEAR button
- 15 ▶|| (play/pause) button
- 16 ▲ (open/close) button

SAFETY-RELATED COMPONENT WARNING!!

COMPONENTS IDENTIFIED BY MARK OR DOTTED LINE WITH MARK ON THE SCHEMATIC DIAGRAMS AND IN THE PARTS LIST ARE CRITICAL TO SAFE OPERATION. REPLACE THESE COMPONENTS WITH SONY PARTS WHOSE PART NUMBERS APPEAR AS SHOWN IN THIS MANUAL OR IN SUPPLEMENTS PUBLISHED BY SONY.

ATTENTION AU COMPOSANT AYANT RAPPORT À LA SÉCURITÉ!

LES COMPOSANTS IDENTIFIÉS PAR UNE MARQUE SUR LES DIAGRAMMES SCHÉMATIQUES ET LA LISTE DES PIÈCES SONT CRITIQUES POUR LA SÉCURITÉ DE FONCTIONNEMENT. NE REMPLACER CES COMPOSANTS QUE PAR DES PIÈCES SONY DONT LES NUMÉROS SONT DONNÉS DANS CE MANUEL OU DANS LES SUPPLÉMENTS PUBLIÉS PAR SONY.

## SECTION 2

### SERVICING NOTES

#### MODEL IDENTIFICATION

— Specification Labels —

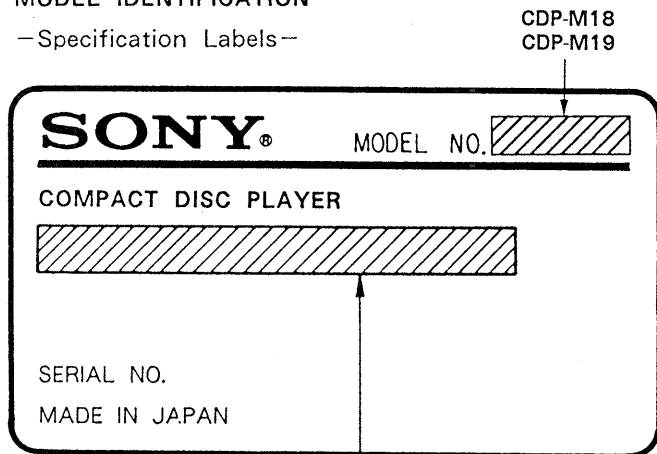

US, Canadian model : AC : 120V 60Hz 10W  
 E, Saudi Arabia,  
 Australian model : AC : 110–120V, 220–240V  
 ~50/60Hz 10W

#### NOTES ON HANDLING THE OPTICAL PICK-UP BLOCK OR BASE UNIT

The laser diode in the optical pick-up block may suffer electrostatic breakdown because of the potential difference generated by the charged electrostatic load, etc. on clothing and the human body.

During repair, pay attention to electrostatic breakdown and also use the procedure in the printed matter which is included in the repair parts.

The flexible board is easily damaged and should be handled with care.

#### NOTES ON LASER DIODE EMISSION CHECK

The laser beam on this model is concentrated so as to be focused on the disc reflective surface by the objective lens in the optical pick-up block. Therefore, when checking the laser diode emission, observe more than 25 cm away from the objective lens.

#### NOTE ON DISASSEMBLY OF BASE UNIT

Disassembly of BASE UNIT (BU-5BD1) is the same as that of CDP-190/390. Please refer to the CDP-190/390 service manual.

## SAFETY CHECK-OUT

After correcting the original service problem, perform the following safety check before releasing the set to the customer:

Check the antenna terminals, metal trim, “metallized” knobs, screws, and all other exposed metal parts for AC leakage. Check leakage as described below.

### LEAKAGE TEST

The AC leakage from any exposed metal part to earth ground and from all exposed metal parts to any exposed metal part having a return to chassis, must not exceed 0.5 mA (500 microampers). Leakage current can be measured by any one of three methods.

1. A commercial leakage tester, such as the Simpson 229 or RCA WT-540A. Follow the manufacturers' instructions to use these instruments.
2. A battery-operated AC milliammeter. The Data Precision 245 digital multimeter is suitable for this job.
3. Measuring the voltage drop across a resistor by means of a VOM or battery-operated AC voltmeter. The “limit” indication is 0.75 V, so analog meters must have an accurate low-voltage scale. The Simpson 250 and Sanwa SH-63Trd are examples of a passive VOM that is suitable. Nearly all battery operated digital multimeters that have a 2 V AC range are suitable. (See Fig. A)

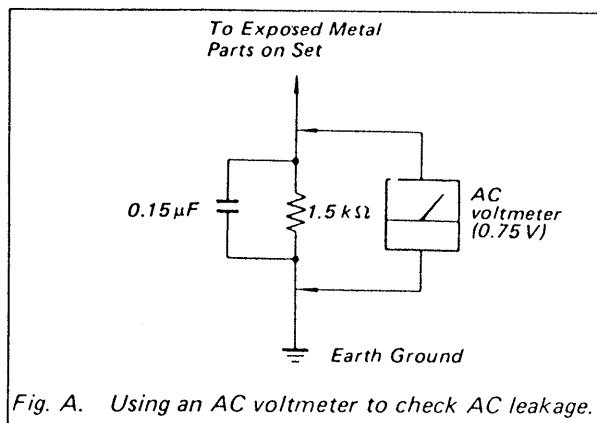

Fig. A. Using an AC voltmeter to check AC leakage.

## SECTION 3

### ELECTRICAL ADJUSTMENTS

1. Perform adjustments in the order given.
2. Use YEDS-18 disc (3-702-101-1) unless otherwise indicated.
3. Use the oscilloscope with more than 10 MΩ impedance.

#### RF Level Check

##### Procedure :

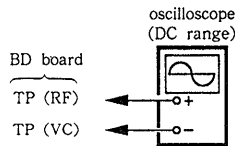

1. Connect oscilloscope to test point TP (RF) and TP (VC) on BD board.
2. Confirm that RF level and eye pattern is optimum. Optimum eye pattern means that shape "◇" can be clearly distinguished at the center of the wave form.

#### RF Signal Reference Waveform (eye pattern)

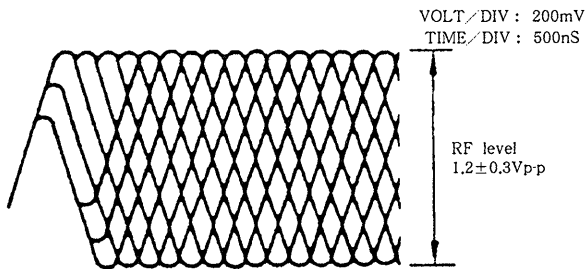

#### REFERENCE

#### E-F Balance Check

##### Procedure :

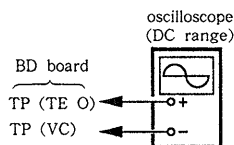

1. Connect test point TP (ADJ) and TP (TES) to ground with lead wire.
2. Connect oscilloscope to test point TP (TE O) and TP (VC) on BD board.
3. Turn POWER switch on.
4. Put disc (YEDS-18) in and playback.
5. Confirm that the oscilloscope waveform is symmetrical on the top and bottom in relation to 0V.
6. After check, remove the lead wire connected in step 1.

**Note :** Take sweep time as long as possible to obtain best waveform.

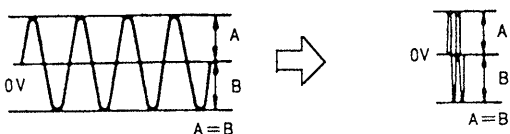

#### RF PLL Free-run Frequency Check

##### Procedure :

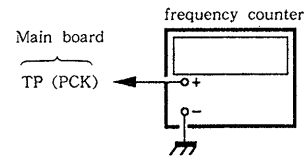

1. Turn POWER switch on.
2. Put disc (YEDS-18) in and playback.
3. Confirm that reading on frequency counter is 4,3218MHz.

#### Focus/Tracking Gain Adjustment

A frequency response analyzer is necessary in order to perform this adjustment exactly.

However, this gain has a margin, so even if it is slightly off, there is no problem. Therefore, do not perform this adjustment.

Focus/tracking gain determines the pick-up follow-up (vertical and horizontal) relative to mechanical noise and mechanical shock when the 2-axis device operate.

However, as these reciprocate, the adjustment is at the point where both are satisfied.

- When gain is raised, the noise when the 2-axis device operates increases.
- When gain is lowered, mechanical shock and skipping occurs more easily.
- When gain adjustment is off, the symptoms below appear.

Symptoms	Gain	Focus	Tracking
• The time until music starts becomes longer for STOP → ▷ PLAY or automatic selection. (◀▶ buttons pressed.) (Normally takes about 1 seconds.)		low	low or high
• Music does not start and disc continues to rotate for STOP → ▷ PLAY or automatic selection. (◀▶ buttons pressed.)		—	low
• Sound is interrupted during PLAY. Or time counter display stops progressing.		—	low
• More noise during 2-axis device operation.		high	high

The following is a simple adjustment method.

#### —Primary Adjustment—

**Note :** Since exact adjustment cannot be performed, remember the positions of the controls before performing the adjustment. If the positions after the primary adjustment are only a little different, return the controls to the original position.

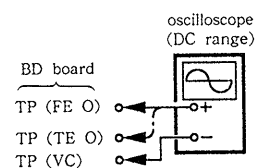

**Procedure :**

1. Keep the set horizontal.  
(If the set is not horizontal, this adjustment cannot be performed due to the gravity against the 2-axis device.)
2. Insert disc (YEDS-18) and press ▷ PLAY button.
3. Connect oscilloscope to TP (FEO) and TP (VC) on BD board.
4. Adjustment RV102 on digital board so that the waveform is as shown in the figure below. (focus gain adjustment)

high tracking gain  
( high fundamental wave )  
than for low gain

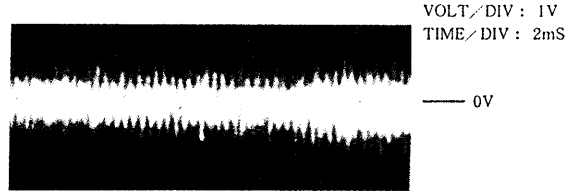

VOLT/DIV : 100mV  
TIME/DIV : 2mS

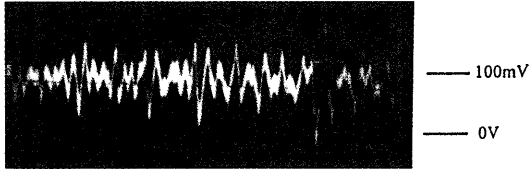

**Adjustment Location :**  
[BD board]

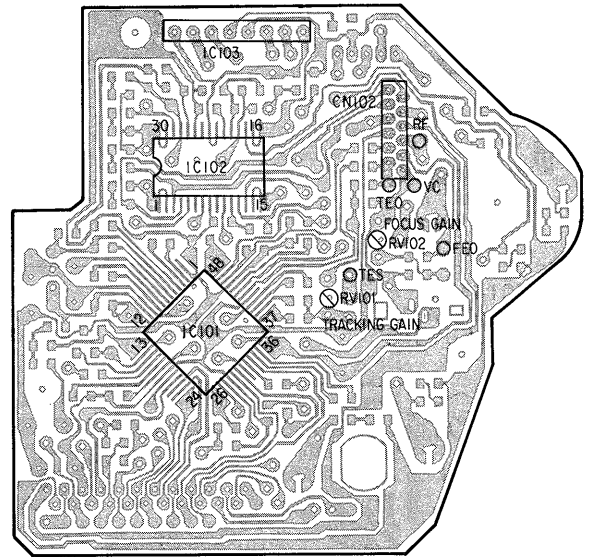

• Inccorrent Examples (DC level changes more than on adjusted waveform)

low focus gain

VOLT/DIV : 100mV  
TIME/DIV : 2mS

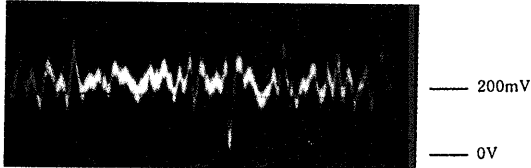

high focus gain

VOLT/DIV : 100mV  
TIME/DIV : 2mS

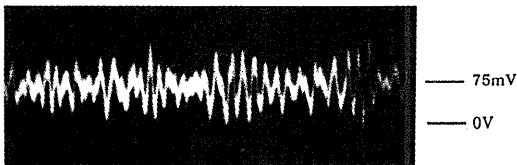

[Main board]

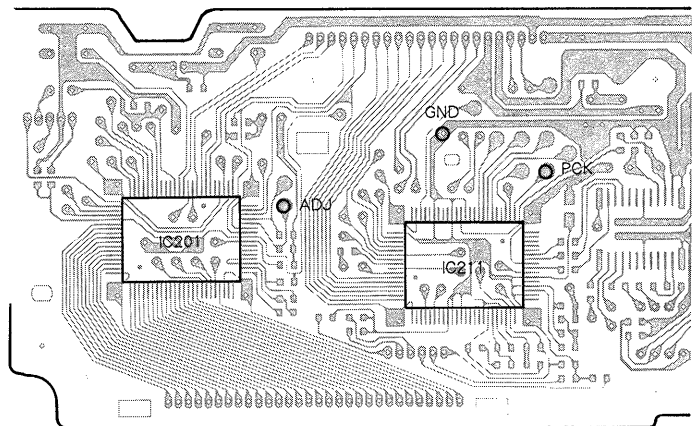

5. Connect oscilloscope to TP (TEO) and TP (VC) on BD board.
6. Adjust RV101 on digital board so that the waveform is as shown the figure below. (tracking gain adjustment)

VOLT/DIV : 1V  
TIME/DIV : 2mS

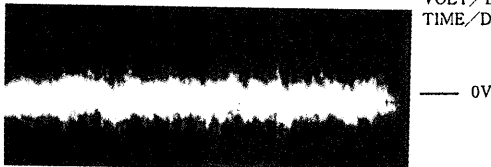

• Incorrect Examples (fundamental wave appears)

low tracking gain

VOLT/DIV : 1V  
TIME/DIV : 2mS

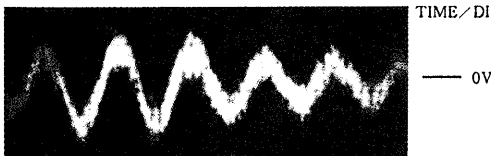

SECTION 4  
DIAGRAMS

4-1. PRINTED WIRING BOARDS

● SEMICONDUCTOR LEAD LAYOUTS

● SEMICONDUCTOR LOCATION

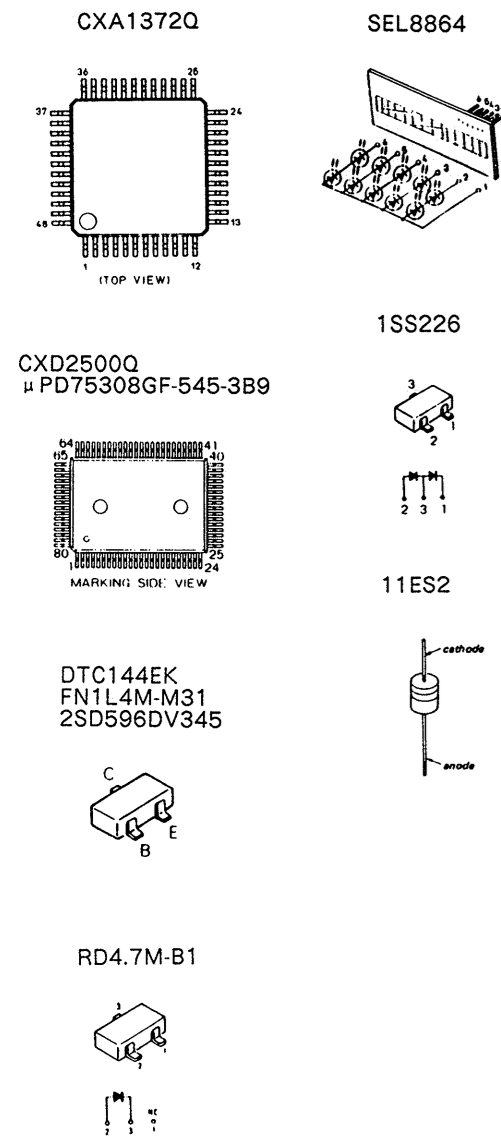

Ref. No.	Location
IC101	C-15
IC102	B-15
IC103	A-15
IC201	G-3
IC202	C-2
IC211	G-6
IC251	C-7
IC252	H-8
IC261	G-8
IC271	G-10
IC291	H-9
Q101	D-16
Q251	H-8
Q271	F-11
Q272	F-11
Q275	G-11
D101	A-16
D201	H-5
D291	H-9
D901	B-3
D902	B-3
D903	B-3
D904	B-3

Note :

- : parts mounted on the conductor side.
- : Through hole.
- : Pattern on the side which is seen.
- : Pattern of the rear side.
- EA : Saudi Arabia
- AUS : Australian

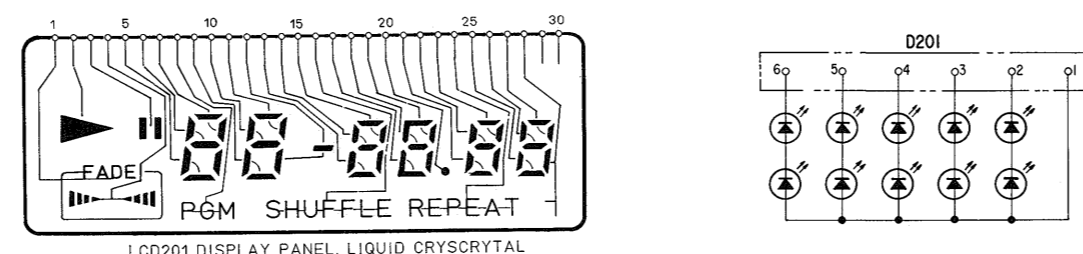
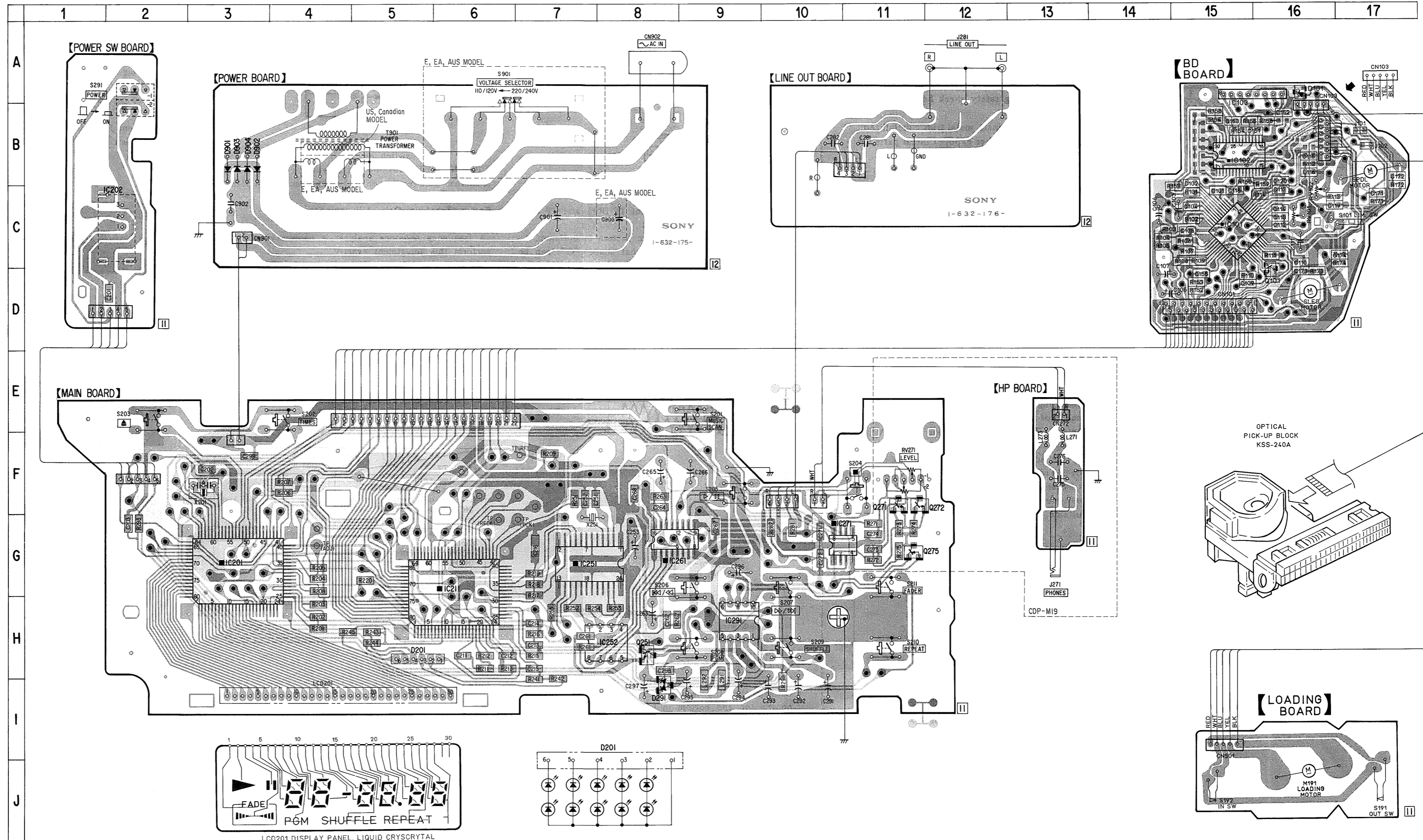



Note :

- All capacitors are in  $\mu F$  unless otherwise noted. pF :  $\mu F$  50WV or less are not indicated except for electrolytics and tantalums.
- All resistors are in  $\Omega$  and  $\frac{1}{4}W$  or less unless otherwise specified.
- $\Delta$  : internal component.

**Note:**  
The components identified by mark  $\Delta$  or dotted line with mark  $\Delta$  are critical for safety. Replace only with part number specified.

**Note:**  
Les composants identifiés par une marque  $\Delta$  sont critiques pour la sécurité. Ne les remplacer que par une pièce portant le numéro spécifié.

- **B+** : B+ Line
- **B-** : B- Line
- $\square$  : adjustment for repair.

- Voltage and waveforms are dc with respect to ground under no-signal conditions.
- no mark : PLAY
- ( ) : STOP
- Voltages are taken with a VOM (input impedance 10M $\Omega$ ). Voltage variations may be noted due to normal production tolerances.
- Waveforms are taken with an oscilloscope. Voltage variations may be noted due to normal production tolerances.
- Circled numbers refer to waveforms.
- Signal path.
- $\Rightarrow$  : CD
- EA : Saudi Arabia
- AUS : Australian

● WAVEFORM

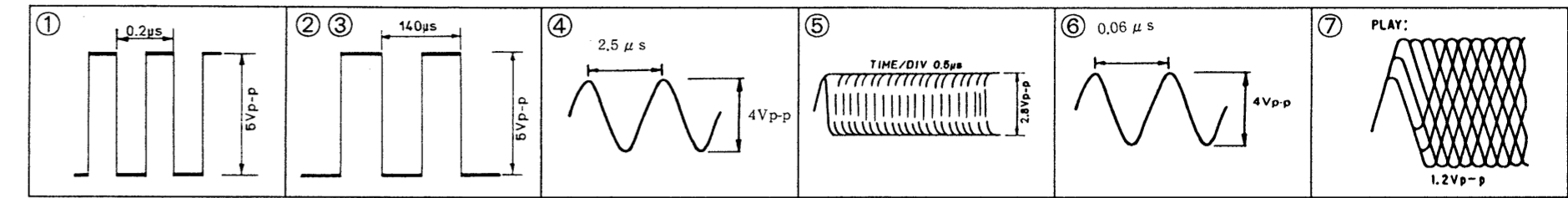

4.2. SCHEMATIC DIAGRAM

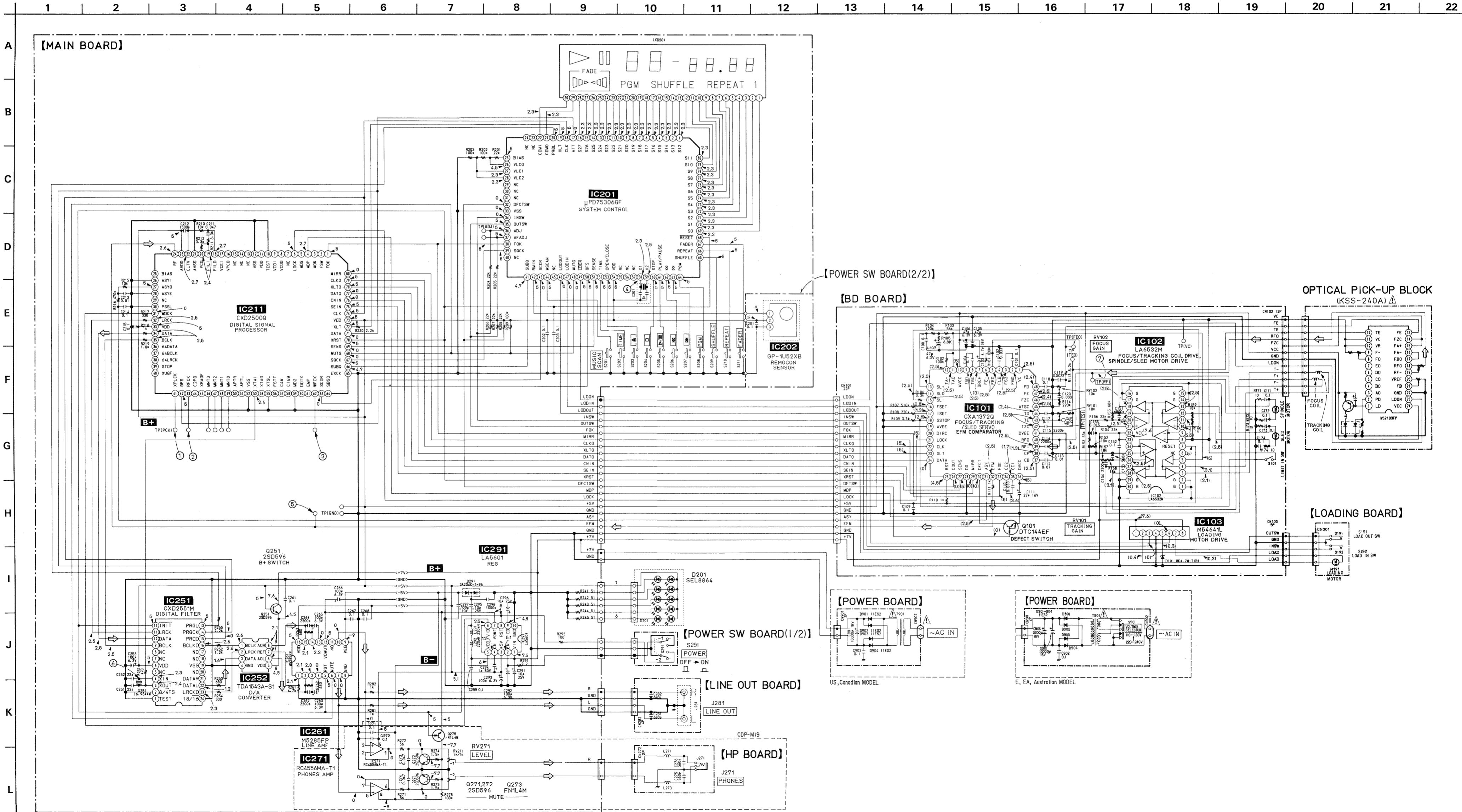

4-3. IC BLOCK DIAGRAM

M5285FP

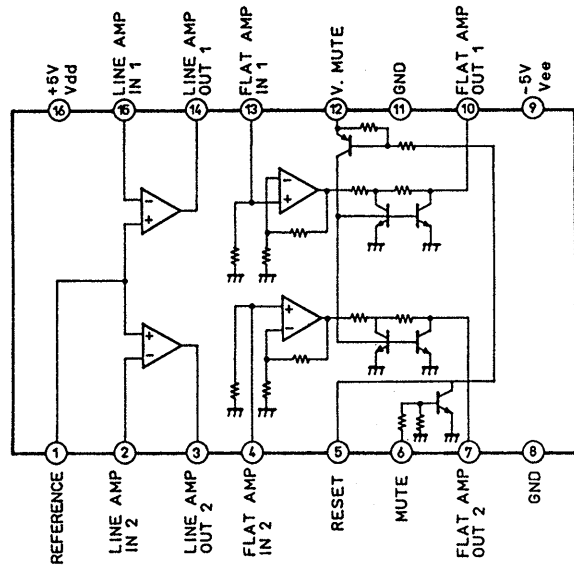

LA6532

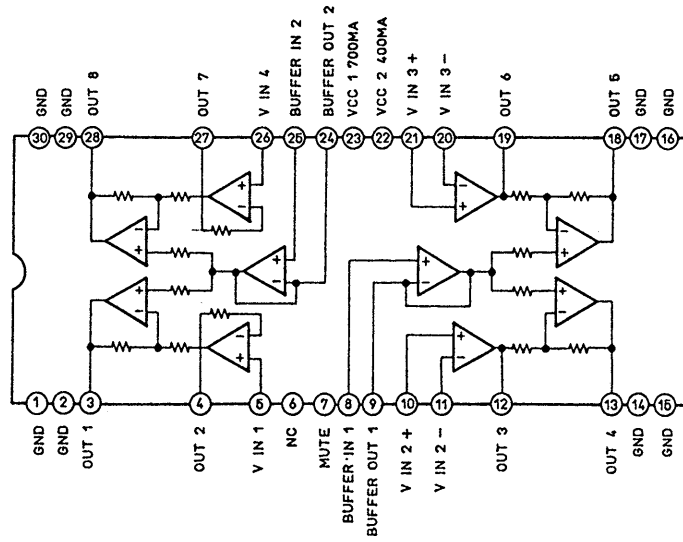

LA5601

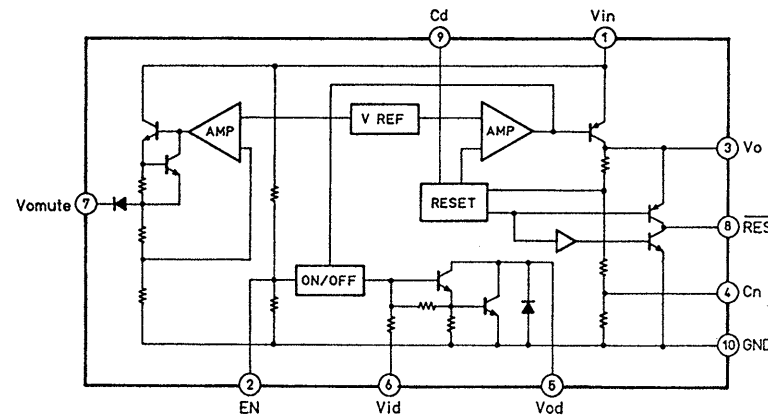

M54641L

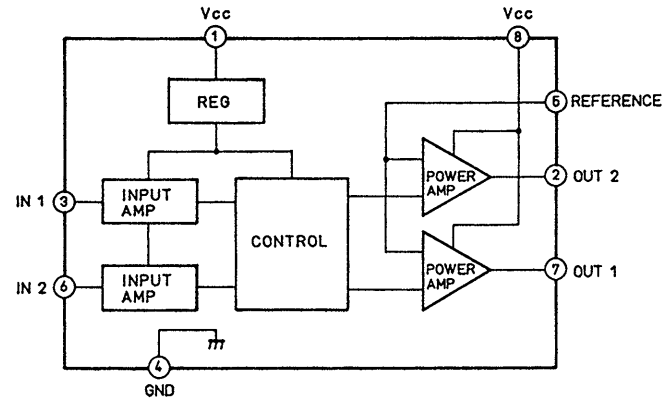

CXA13720

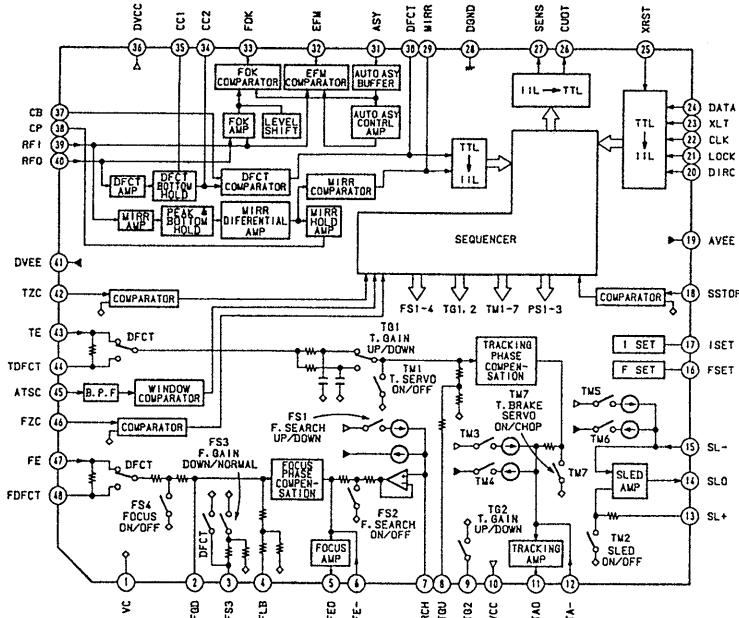

TDA1543

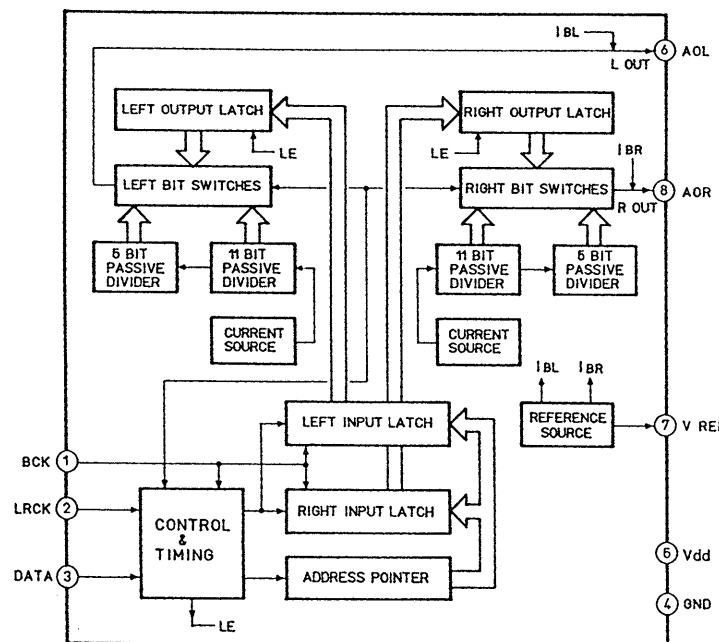

CXD2551M

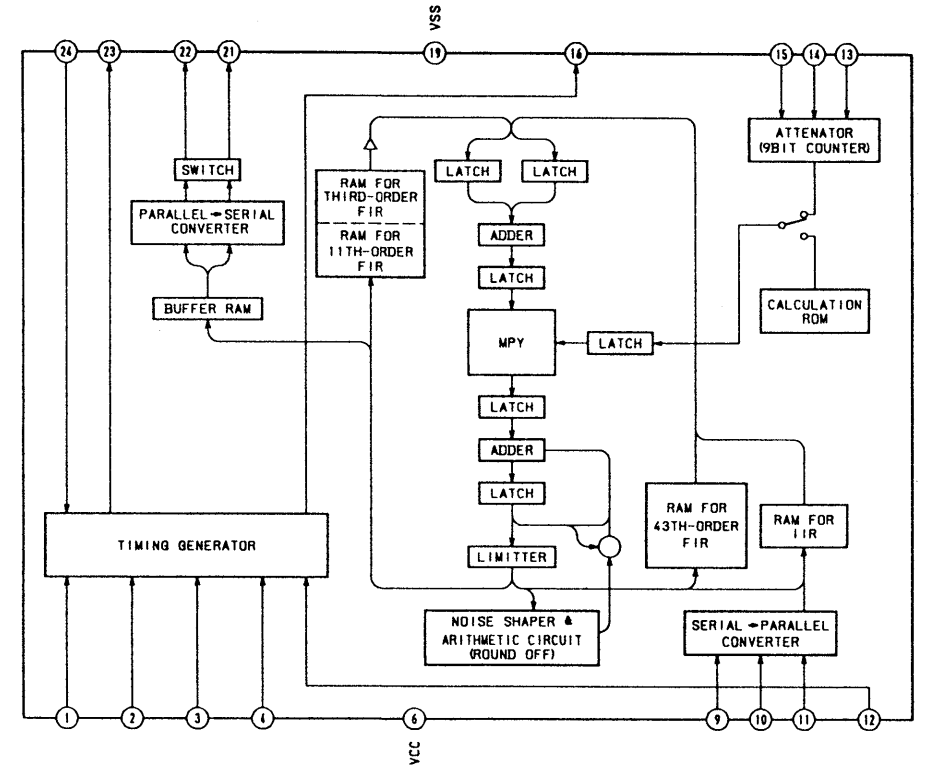

CXD2500

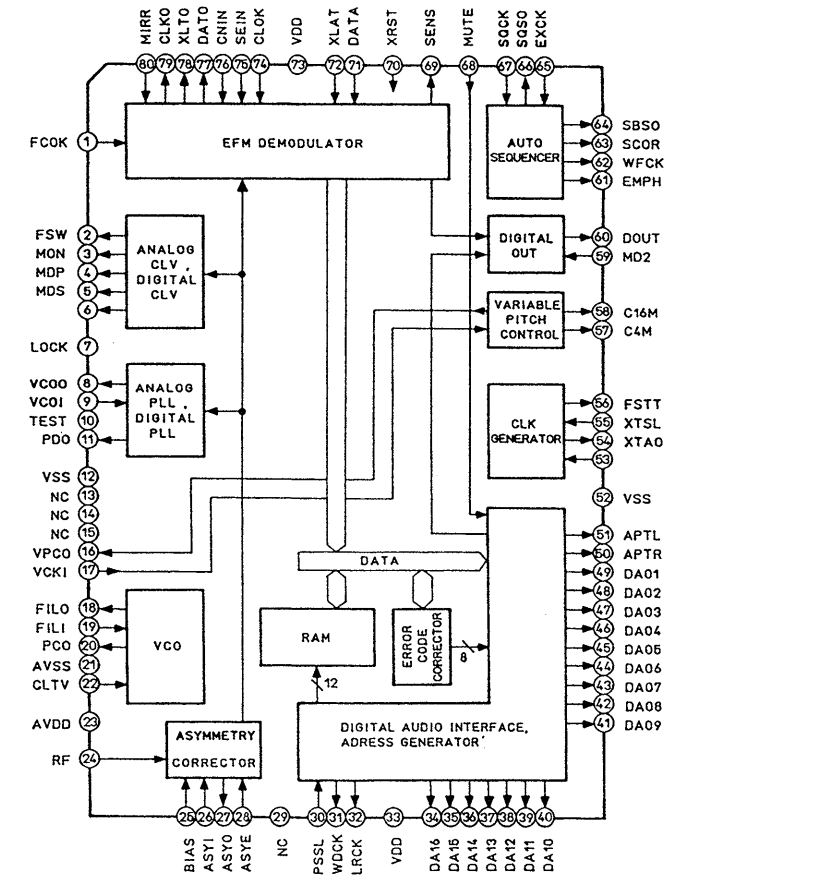





## SECTION 5 EXPLODED VIEWS

**NOTE:**

- The mechanical parts with no reference number in the exploded views are not supplied.
- The construction parts of an assembled part are indicated with a collation number in the remark column.
- Items marked "★" are not stocked since they are seldom required for routine service. Some delay should be anticipated when ordering these items.
- Due to standardization, parts with part number suffix -XX and -X may be different from the parts specified in the components used on the set.
- Color Indication of Appearance Parts  
Example:  
(RED) ... KNOB, BALANCE (WHITE)  
↑   ↑  
Cabinet's Color                                     Parts Color
- AUS : Australian  
EA : Saudi Arabia

The components identified by mark  or dotted line with mark  are critical for safety. Replace only with part number specified.

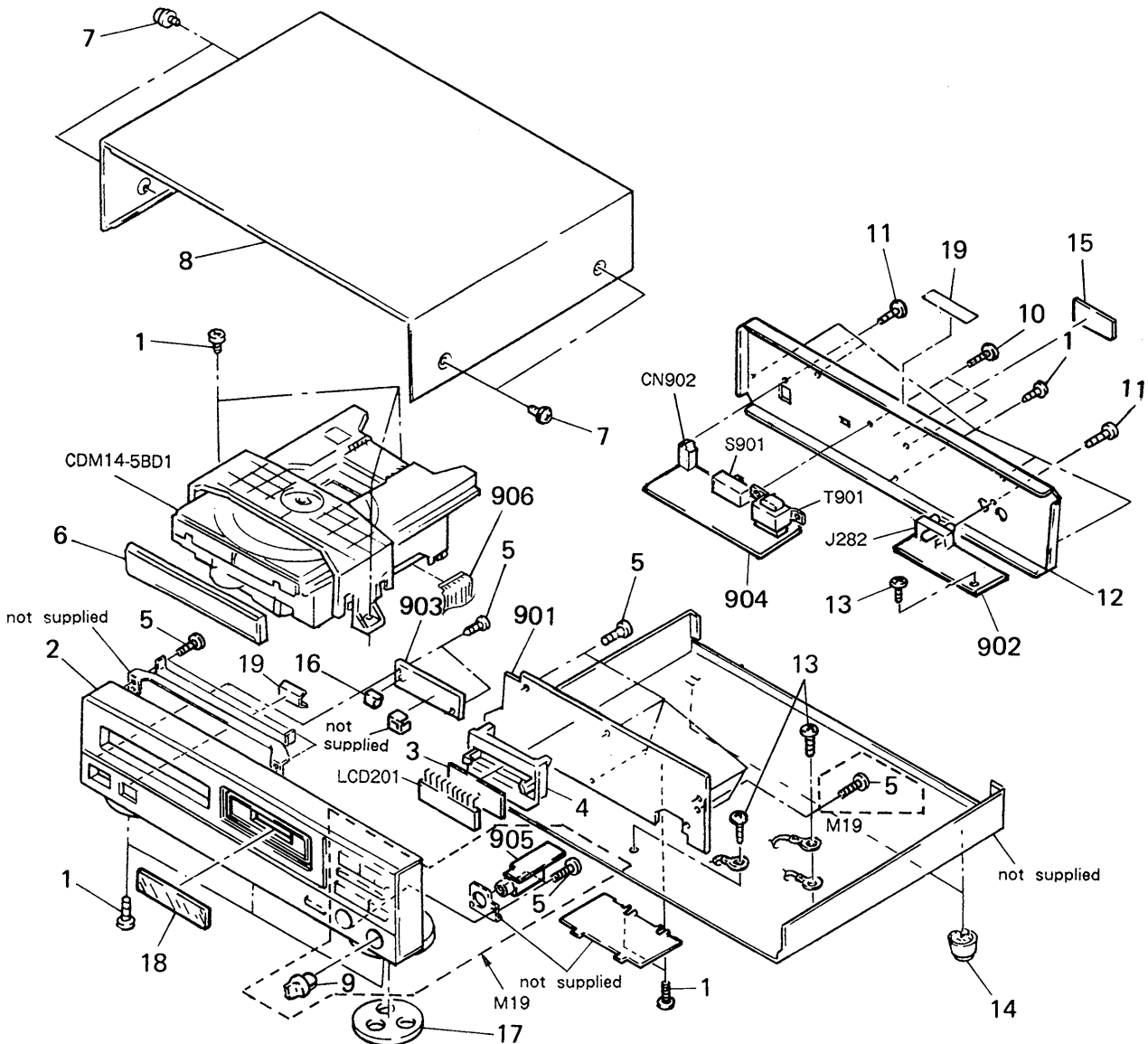

Les composants identifiés par une marque  sont critiques pour la sécurité. Ne les remplacer que par une pièce portant le numéro spécifié.

**(1) CHASSIS SECTION**



No.	Part No.	Description	Remarks	No.	Part No.	Description	Remarks
1	7-682-548-09	SCREW +BVT 3X8 (S)		13	7-682-547-04	SCREW +BVT 3X6 (S)	
2	X-4917-588-3	(M19:US).....PANEL ASSY, FRONT		14	4-933-601-01	FOOT	
	X-4917-589-3	(M19:Canadian)...PANEL ASSY, FRONT		15	*4-885-838-01	(E,EA,AUS)...LABEL, CLASS 1	
	X-4917-590-3	(M19:E,EA,AUS) ....PANEL ASSY, FRONT (BLACK)		16	4-927-341-01	BUTTON (POWER)	
	X-4917-591-3	(M19:E,EA,AUS) ....PANEL ASSY, FRONT (GRAY)		17	*4-921-906-01	FELT	
	X-4917-594-3	(M18).....PANEL ASSY, FRONT		18	4-927-351-03	PLATE, INDICATION	
3	*4-933-114-01	ILLUMINATOR		19	*4-937-504-01	(EXCEPT US)...SHEET (REMOTE CONTROL)	
4	*4-933-121-01	HOLDER (LCD)			*4-937-504-12	(US).....SHEET (REMOTE CONTROL)	
5	4-928-635-01	SCREW, +BV (2.6X8) TAPPING		901	*A-4617-196-A	(M19)...MOUNTED PCB, MAIN	
6	4-927-339-01	(E,EA,AUS).....PANEL, LOADING (BLACK)			*A-4617-394-A	(M18)...MOUNTED PCB, MAIN	
	4-927-339-12	(M19:Canadian)...PANEL, LOADING		902	*1-632-176-11	PC BOARD, LINE OUT	
	4-927-339-21	(E,EA,AUS).....PANEL, LOADING (GRAY)		903	*1-634-305-11	PC BOARD, POWER SW	
	4-927-339-31	(US).....PANEL, LOADING		904	*1-632-175-11	PC BOARD, POWER	
7	3-704-366-01	SCREW (CASE)(M3X8)		905	*1-634-306-11	(M19)...PC BOARD, HP	
8	4-919-376-31	(BLACK)...CASE		906	1-535-798-11	JUMPER, FILM (WITH TERMINAL)	
	4-919-376-81	(GRAY)....CASE		CN902A	1-526-929-11	(E).....INLET, AC	
9	4-933-116-11	(M19)...KNOB (C, TYPE), LOV		CN902A	1-526-930-11	(US,Canadian)...INLET, AC	
10	4-820-330-31	SCREW		CN902A	1-526-931-11	(EA,AUS).....INLET, AC	
11	7-685-646-79	SCREW +BVT 3X8 TYPE2 N-S		J281	1-566-921-11	JACK, PIN 2P (LINE OUT)	
12	*4-927-327-11	(E,EA).....PANEL, BACK		LCD201	1-808-794-31	DISPLAY PANEL, LIQUID CRYSTAL	
	*4-927-327-22	(US).....PANEL, BACK		S901	A 1-571-722-11	(E,EA,AUS)...SWITCH, VOLTAGE SELECTION (120/220V)	
	*4-927-327-31	(M19:Canadian)...PANEL, BACK					
	*4-927-327-51	(M18).....PANEL, BACK					
	*4-927-327-61	(AUS).....PANEL, BACK					

**Note:**

The components identified by mark  or dotted line with mark  are critical for safety. Replace only with part number specified.

**Note:**

Les composants identifiés par une marque  sont critiques pour la sécurité. Ne les remplacer que par une pièce portant le numéro spécifié.

(2) CD MECHANISM SECTION (CDM14-5BD1)

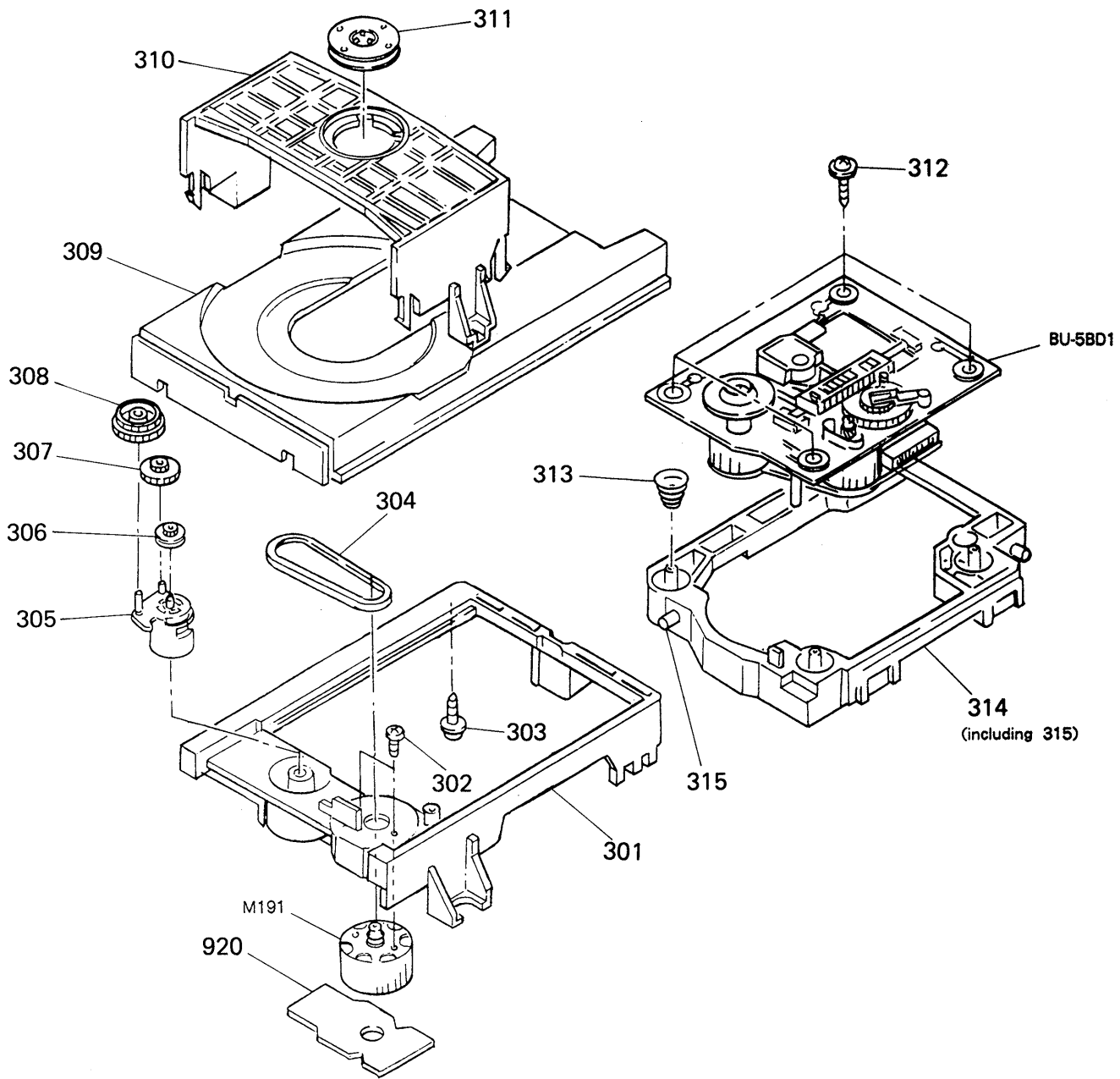

No.	Part No.	Description	Remarks
301	4-933-111-01	CHASSIS (MD)	
302	7-621-775-10	SCREW +B 2.6X4	
303	*4-917-583-21	BRACKET, YOKE	
304	4-927-649-01	BELT	
305	4-933-109-01	CAM	
306	4-927-651-01	PULLEY (S)	
307	4-927-628-01	GEAR (C)	
308	4-933-107-01	GEAR (PL)	
309	4-933-112-01	TABLE, DISK	

No.	Part No.	Description	Remarks
310	4-933-110-01	HOLDER (MG)	
311	A-4675-347-A	MG ASSY	
312	4-933-134-01	SCREW (+PTPWH M2.6X6)	
313	4-917-541-01	SPRING (B)	
314	4-933-129-01	HOLDER (BU)	
315	4-933-108-01	SHAFT (CAM)	
920	*1-632-202-11	PC BOARD, LOADING	
M191	A-4604-363-A	MOTOR (L) ASSY	

(3) OPTICAL PICK-UP BLOCK (BU-5BD1)

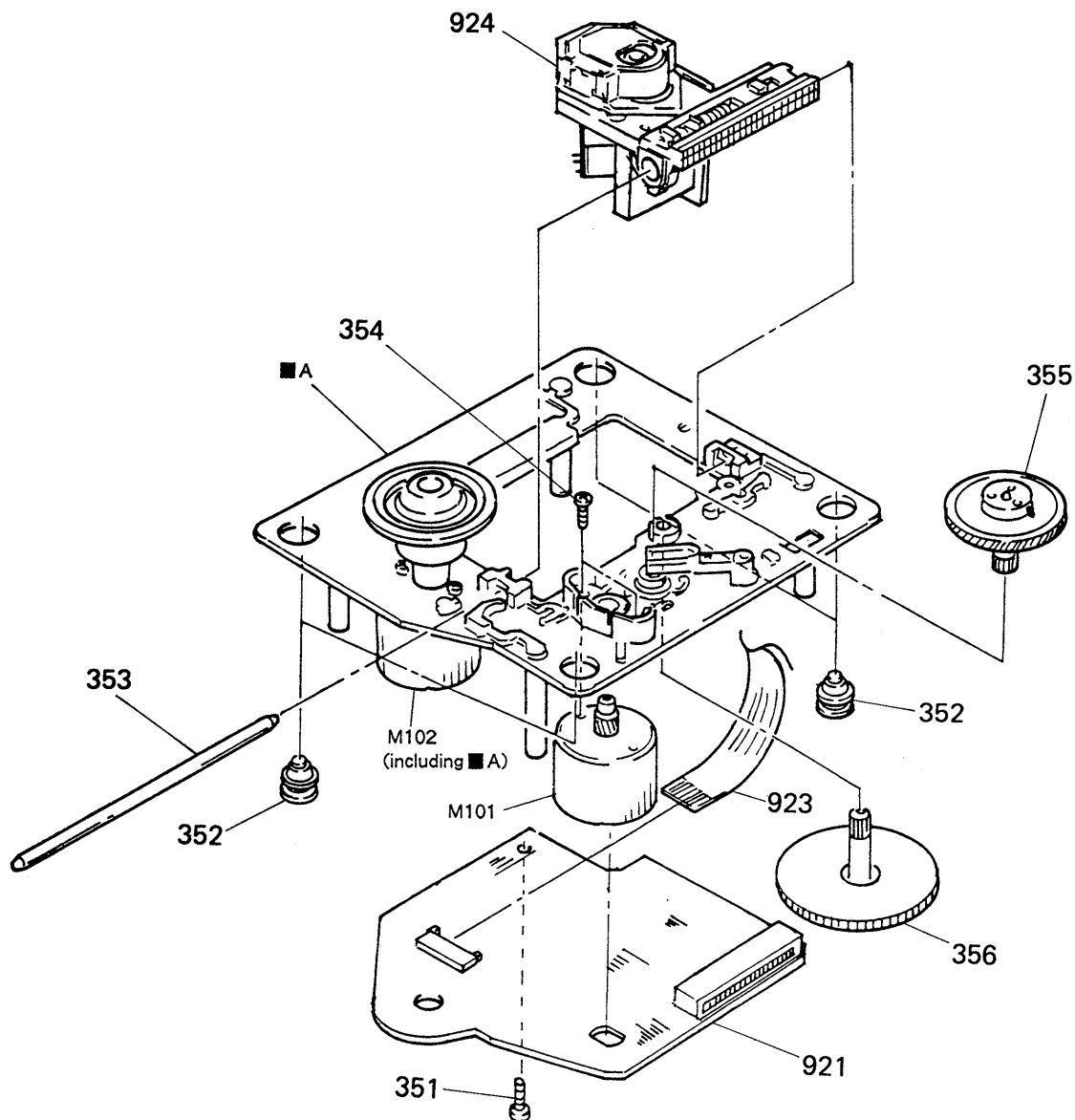

<p><b>Note:</b> The components identified by mark  or dotted line with mark  are critical for safety. Replace only with part number specified.</p>	<p><b>Note:</b> Les composants identifiés par une marque  sont critiques pour la sécurité. Ne les remplacer que par une pièce portant le numéro spécifié.</p>
--	---

No.	Part No.	Description	Remarks	No.	Part No.	Description	Remarks
351	7-685-134-19	SCREW +BTP 2.6X8 TYPE2 N-S		921	*A-4617-161-A	MOUNTED PCB, BD	
352	4-933-126-01	INSULATOR (A)		923	1-575-001-11	WIRE, FLAT TYPE (12 CORE)	
353	4-917-565-01	SHAFT, SLED		924	8-848-144-11	DEVICE, OPTICAL KSS-240A	
354	7-621-255-15	SCREW +P 2X3		M101	X-4917-504-1	ASSY, MOTOR (SLED)	
355	4-917-567-01	GEAR (M)		M102	X-4917-523-1	ASSY, MOTOR (SPINDLE)	
356	4-917-564-01	GEAR (P), FLATNESS					

## SECTION 6 ELECTRICAL PARTS LIST

**NOTE:**

- Due to standardization, replacements in the parts list may be different from the parts specified in the diagrams or the components used on the set.
- Items marked "★" are not stocked since they are seldom required for routine service. Some delay should be anticipated when ordering these items.
- If there are two or more same circuits in a set such as a stereophonic machine, only typical circuit parts may be indicated and capacitors and resistors in other same circuits may be omitted.

**CAPACITORS:**

MF:  $\mu F$ , PF:  $\mu F$ .

**RESISTORS**

- All resistors are in ohms.
- F: nonflammable

**COILS**

- MMH: mH, UH:  $\mu H$

**SEMICONDUCTORS**

In each case, U:  $\mu$ , for example:

UA...:  $\mu A$ ..., UPA...:  $\mu PA$ ...,

UPC...:  $\mu PC$ , UPD...:  $\mu PD$ ...

- AUS: Australian
- EA: Saudi Arabia

The components identified by mark  $\Delta$  or dotted line with mark  $\Delta$  are critical for safety. Replace only with part number specified.

Les composants identifiés par une marque  $\Delta$  sont critiques pour la sécurité. Ne les remplacer que par une pièce portant le numéro spécifié.

Ref.No.	Part No.	Description	Ref.No.	Part No.	Description
901	*A-4617-196-A	(M19)...MOUNTED PCB, MAIN	C214	1-163-038-00	CERAMIC CHIP 0.1MF
	*A-4617-394-A	(M18)...MOUNTED PCB, MAIN	C215	1-163-038-00	CERAMIC CHIP 0.1MF
902	*1-632-176-11	PC BOARD, LINE OUT	C216	1-135-091-00	TANTAL. CHIP 1MF
903	*1-634-305-11	PC BOARD, POWER SW			20% 16V
904	*1-632-175-11	PC BOARD, POWER	C251	1-163-101-00	CERAMIC CHIP 22PF
			C252	1-163-101-00	CERAMIC CHIP 22PF
905	*1-634-306-11	(M19)...PC BOARD, HP	C253	1-124-225-00	ELECT 100MF
906	1-535-798-11	JUMPER, FILM (WITH TERMINAL)			5% 50V
920	*1-632-202-11	PC BOARD, LOADING	C261	1-163-038-00	CERAMIC CHIP 0.1MF
			C262	1-164-161-11	CERAMIC CHIP 0.0022MF
921	*A-4617-161-A	MOUNTED PCB, BD	C263	1-124-225-00	ELECT 100MF
923	1-575-001-11	WIRE, FLAT TYPE (12 CORE)			10% 50V
924	$\Delta$ 8-848-144-11	DEVICE, OPTICAL KSS-240A	C264	1-164-161-11	CERAMIC CHIP 0.0022MF
			C265	1-124-225-00	ELECT 100MF
C101	1-163-038-00	CERAMIC CHIP 0.1MF	C266	1-124-225-00	ELECT 100MF
C102	1-163-989-11	CERAMIC CHIP 0.033MF			20% 6.3V
C103	1-126-094-11	ELECT 4.7MF	C267	1-163-038-00	CERAMIC CHIP 0.1MF
		20% 16V	C268	1-163-038-00	CERAMIC CHIP 0.1MF
C104	1-163-038-00	CERAMIC CHIP 0.1MF	C271	1-163-038-00	(M19)...CERAMIC CHIP 0.1MF
C105	1-126-154-11	ELECT 47MF			25V
C106	1-126-154-11	ELECT 47MF	C272	1-163-038-00	(M19)...CERAMIC CHIP 0.1MF
		20% 6.3V	C273	1-163-035-00	(M19)...CERAMIC CHIP 0.047MF
C107	1-126-154-11	ELECT 47MF	C274	1-163-035-00	(M19)...CERAMIC CHIP 0.047MF
C108	1-163-038-00	CERAMIC CHIP 0.1MF			50V
C109	1-163-038-00	CERAMIC CHIP 0.1MF	C275	1-130-468-00	(M19)...MYLAR 560PF
		25V	C276	1-130-468-00	(M19)...MYLAR 560PF
C110	1-163-989-11	CERAMIC CHIP 0.033MF	C281	1-130-469-00	MYLAR 680PF
C111	1-131-367-00	TANTALUM 22MF			5% 50V
C112	1-164-232-11	CERAMIC CHIP 0.01MF	C282	1-130-469-00	MYLAR 680PF
		10% 50V	C291	1-126-096-11	ELECT 10MF
C113	1-164-232-11	CERAMIC CHIP 0.01MF	C292	1-124-225-00	ELECT 100MF
C114	1-164-161-11	CERAMIC CHIP 0.0022MF			20% 25V
C115	1-164-161-11	CERAMIC CHIP 0.0022MF	C293	1-124-225-00	ELECT 100MF
		10% 50V	C294	1-126-160-11	ELECT 1MF
C117	1-163-038-00	CERAMIC CHIP 0.1MF	C295	1-126-096-11	ELECT 10MF
C118	1-163-038-00	CERAMIC CHIP 0.1MF			20% 25V
C119	1-164-161-11	CERAMIC CHIP 0.0022MF	C297	1-124-584-00	ELECT 100MF
		10% 50V	C298	1-163-009-11	CERAMIC CHIP 0.001MF
C120	1-163-989-11	CERAMIC CHIP 0.033MF			10% 50V
C151	1-163-019-00	CERAMIC CHIP 0.0068MF	C299	1-163-038-00	CERAMIC CHIP 0.1MF
C152	1-163-038-00	CERAMIC CHIP 0.1MF	C901	1-126-939-11	ELECT 10000MF
		25V	C902	1-162-851-11	CERAMIC 0.1MF
C153	1-163-006-11	CERAMIC CHIP 560PF	C903	1-124-887-00	(E,EA,AUS)...ELECT 3300MF
C154	1-164-161-11	CERAMIC CHIP 0.0022MF			20% 16V
C155	1-163-023-00	CERAMIC CHIP 0.015MF			20% 16V
		10% 50V	CN101	1-568-796-11	SOCKET, CONNECTOR 22P
C171	1-163-038-00	CERAMIC CHIP 0.1MF	CN102	1-568-795-11	SOCKET, CONNECTOR 12P
C172	1-163-038-00	CERAMIC CHIP 0.1MF	CN103	*1-564-721-11	PIN, CONNECTOR (SMALL TYPE) 5P
C173	1-163-038-00	CERAMIC CHIP 0.1MF			
		25V	CN272	*1-564-495-11	(M19)...PIN, CONNECTOR 2P
C174	1-163-038-00	CERAMIC CHIP 0.1MF	CN282	*1-564-706-11	PIN, CONNECTOR (SMALL TYPE) 4P
C201	1-163-038-00	CERAMIC CHIP 0.1MF	CN301	*1-564-707-11	PIN, CONNECTOR (SMALL TYPE) 5P
C202	1-163-038-00	CERAMIC CHIP 0.1MF	CN901	*1-564-704-11	PIN, CONNECTOR (SMALL TYPE) 2P
		25V			
C203	1-163-038-00	CERAMIC CHIP 0.1MF	CN902A	1-526-929-11	(E).....INLET, AC
C211	1-163-809-11	CERAMIC CHIP 0.047MF	CN902A	1-526-930-11	(US,Canadian)...INLET, AC
C212	1-163-011-11	CERAMIC CHIP 0.0015MF	CN902A	1-526-931-11	(EA,AUS).....INLET, AC
C213	1-164-232-11	CERAMIC CHIP 0.01MF			
		50V	D101	8-719-105-72	DIODE RD4.7M-B1
			D201	1-808-805-11	DIODE SEL8864
			D291	8-719-800-76	DIODE 1SS226

Ref.No.	Part No.	Description	Ref.No.	Part No.	Description			
D901	8-719-200-82	DIODE 11ES2	R153	1-216-085-00	METAL GLAZE	33K	5%	1/10W
D902	8-719-200-82	DIODE 11ES2	R154	1-216-085-00	METAL GLAZE	33K	5%	1/10W
D903	8-719-200-82	DIODE 11ES2	R155	1-216-093-00	METAL GLAZE	68K	5%	1/10W
D904	8-719-200-82	DIODE 11ES2						
IC101	8-752-037-33	IC CXA1372Q	R156	1-216-081-00	METAL GLAZE	22K	5%	1/10W
IC102	8-759-821-94	IC LA6532M	R157	1-216-079-00	METAL GLAZE	18K	5%	1/10W
IC103	8-759-633-65	IC M54641L	R158	1-216-079-00	METAL GLAZE	18K	5%	1/10W
IC201	8-759-149-91	IC UPD75308GF-545-3B9	R159	1-216-079-00	METAL GLAZE	18K	5%	1/10W
IC202	8-749-920-83	IC GP1U52XB	R160	1-216-049-00	METAL GLAZE	1K	5%	1/10W
IC211	8-752-333-31	IC CXD2500Q	R171	1-216-001-00	METAL GLAZE	10	5%	1/10W
IC251	8-752-334-07	IC CXD2551M	R172	1-216-001-00	METAL GLAZE	10	5%	1/10W
IC252	8-759-990-13	IC TDA1543A-S1	R173	1-216-001-00	METAL GLAZE	10	5%	1/10W
IC261	8-759-633-66	IC M5285FP	R174	1-216-001-00	METAL GLAZE	10	5%	1/10W
IC271	8-759-981-86	(M19)...IC RC4556MA	R201	1-216-081-00	METAL GLAZE	22K	5%	1/10W
IC291	8-759-821-93	IC LA5601	R202	1-216-097-00	METAL GLAZE	100K	5%	1/10W
J271	1-568-519-21	(M19)...JACK, LARGE TYPE (PHONES)	R203	1-216-097-00	METAL GLAZE	100K	5%	1/10W
J281	1-566-921-11	JACK, PIN 2P (LINE OUT)	R204	1-216-081-00	METAL GLAZE	22K	5%	1/10W
L271	1-424-090-11	(M19)...COIL, LINE FILTER	R205	1-216-081-00	METAL GLAZE	22K	5%	1/10W
L273	1-424-090-11	(M19)...COIL, LINE FILTER	R206	1-216-081-00	METAL GLAZE	22K	5%	1/10W
L291	1-410-658-31	INDUCTOR CHIP 220UH	R207	1-216-081-00	METAL GLAZE	22K	5%	1/10W
L292	1-410-658-31	INDUCTOR CHIP 220UH	R208	1-216-081-00	METAL GLAZE	22K	5%	1/10W
LCD201	1-808-794-31	DISPLAY PANEL, LIQUID CRYSTAL	R209	1-216-097-00	METAL GLAZE	100K	5%	1/10W
M101	X-4917-504-1	ASSY, MOTOR (SLED)	R211	1-216-061-00	METAL GLAZE	3.3K	5%	1/10W
M102	X-4917-523-3	ASSY, BASE (SPINDLE)	R212	1-216-061-00	METAL GLAZE	3.3K	5%	1/10W
M191	A-4604-363-A	MOTOR (L) ASSY	R213	1-216-073-00	METAL GLAZE	10K	5%	1/10W
Q101	8-729-901-01	TRANSISTOR DTC144EK	R215	1-216-073-00	METAL GLAZE	10K	5%	1/10W
Q251	8-729-141-75	TRANSISTOR 2SD596-DV345	R216	1-216-113-00	METAL GLAZE	470K	5%	1/10W
Q271	8-729-141-75	(M19)...TRANSISTOR 2SD596-DV345	R217	1-216-037-00	METAL GLAZE	330	5%	1/10W
Q272	8-729-141-75	(M19)...TRANSISTOR 2SD596-DV345	R218	1-216-049-00	METAL GLAZE	1K	5%	1/10W
Q273	8-729-113-66	(M19)...TRANSISTOR FN1L4M-M31	R219	1-216-055-00	METAL GLAZE	1.8K	5%	1/10W
R101	1-216-097-00	METAL GLAZE	100K	5%	1/10W			
R102	1-216-097-00	METAL GLAZE	100K	5%	1/10W			
R103	1-216-091-00	METAL GLAZE	56K	5%	1/10W			
R104	1-216-099-00	METAL GLAZE	120K	5%	1/10W			
R105	1-216-069-00	METAL GLAZE	6.8K	5%	1/10W			
R106	1-216-061-00	METAL GLAZE	3.3K	5%	1/10W			
R107	1-216-114-00	METAL GLAZE	510K	5%	1/10W			
R108	1-216-105-00	METAL GLAZE	220K	5%	1/10W			
R109	1-216-061-00	METAL GLAZE	3.3K	5%	1/10W			
R110	1-216-049-00	METAL GLAZE	1K	5%	1/10W			
R111	1-216-049-00	METAL GLAZE	1K	5%	1/10W			
R112	1-216-083-00	METAL GLAZE	27K	5%	1/10W			
R113	1-216-071-00	METAL GLAZE	8.2K	5%	1/10W			
R114	1-216-105-00	METAL GLAZE	220K	5%	1/10W			
R152	1-216-073-00	METAL GLAZE	10K	5%	1/10W			
R219	1-216-055-00	METAL GLAZE	1.8K	5%	1/10W			
R220	1-216-057-00	METAL GLAZE	2.2K	5%	1/10W			
R241	1-216-018-00	METAL GLAZE	51	5%	1/10W			
R242	1-216-018-00	METAL GLAZE	51	5%	1/10W			
R243	1-216-018-00	METAL GLAZE	51	5%	1/10W			
R244	1-216-018-00	METAL GLAZE	51	5%	1/10W			
R245	1-216-018-00	METAL GLAZE	51	5%	1/10W			
R251	1-216-041-00	METAL GLAZE	470	5%	1/10W			
R252	1-216-051-00	METAL GLAZE	1.2K	5%	1/10W			
R253	1-216-045-00	METAL GLAZE	680	5%	1/10W			
R254	1-216-037-00	METAL GLAZE	330	5%	1/10W			
R255	1-216-057-00	METAL GLAZE	2.2K	5%	1/10W			
R261	1-216-065-00	METAL GLAZE	4.7K	5%	1/10W			
R262	1-216-045-00	METAL GLAZE	680	5%	1/10W			
R263	1-216-045-00	METAL GLAZE	680	5%	1/10W			
R271	1-216-019-00	(M19)...METAL GLAZE	56	5%	1/10W			
R272	1-216-019-00	(M19)...METAL GLAZE	56	5%	1/10W			



Ref.No.	Part No.	Description
R273	1-216-053-00	(M19)...METAL GLAZE 1.5K 5% 1/10W
R274	1-216-053-00	(M19)...METAL GLAZE 1.5K 5% 1/10W
R275	1-216-097-00	(M19)...METAL GLAZE 100K 5% 1/10W
R281	1-216-049-00	METAL GLAZE 1K 5% 1/10W
R282	1-216-049-00	METAL GLAZE 1K 5% 1/10W
R291	1-216-298-00	METAL GLAZE 2.2 5% 1/10W
R293	1-216-025-00	METAL GLAZE 100 5% 1/10W
RV101	1-238-016-11	RES, ADJ, CARBON 10K (TRACKING GAIN)
RV102	1-238-016-11	RES, ADJ, CARBON 10K (FOCUS GAIN)
RV271	1-238-748-11	(M19)...RES, VAR, CARBON 1K/1K(LEVEL)
S101	1-572-085-11	SWITCH, LEAF (LIMIT SW)
S191	1-572-086-11	SWITCH, LEAF (OUT SW)
S192	1-572-086-11	SWITCH, LEAF (IN SW)
S201	1-554-303-21	SWITCH, KEY BOARD (MUSIC SCAN)
S202	1-554-303-21	SWITCH, KEY BOARD (TIMES)
S203	1-554-303-21	SWITCH, KEY BOARD (OPEN/CLOSE)
S204	1-554-303-21	SWITCH, KEY BOARD (■)
S205	1-554-303-21	SWITCH, KEY BOARD (▷/Ⓜ)
S206	1-554-303-21	SWITCH, KEY BOARD (Ⓜ/◁)
S207	1-554-303-21	SWITCH, KEY BOARD (▷▷/▷▷)
S208	1-554-303-21	SWITCH, KEY BOARD (PGM)
S209	1-554-303-21	SWITCH, KEY BOARD (SHUFFLE)
S210	1-554-303-21	SWITCH, KEY BOARD (REPEAT)
S211	1-554-303-21	SWITCH, KEY BOARD (FADER)
S291	1-571-305-11	SWITCH, PUSH (1 KEY)(POWER)
S901	△,1-571-722-11	(E,EA,AUS)...SWITCH, VOLTAGE SELECTION (120/220V)
T901	△,1-449-824-11	(US,Canadian)...TRANSFORMER, POWER
T901	△,1-450-011-11	(E,EA,AUS).....TRANSFORMER, POWER
X201	1-567-775-11	VIBRATOR, CERAMIC
X251	1-567-908-11	VIBRATOR, CRYSTAL

ACCESSORY & PACKING MATERIAL

△,1-555-074-11	(AUS).....CORD, POWER
△,1-556-280-00	(E).....CORD, POWER
△,1-558-834-11	(US,Canadian)...CORD, POWER
△,1-558-835-11	(EA).....CORD, POWER
1-559-533-11	CORD, CONNECTION
△,1-569-007-11	(E)...ADAPTOR, CONVERSION 2P
△,1-569-008-11	(EA)...ADAPTOR, CONVERSION 2P
3-750-716-11	(M19:EXCEPT US)...MANUAL, INSTRUCTION
3-750-716-21	(US).....MANUAL, INSTRUCTION
*3-795-629-11	INSTRUCTION
*4-922-998-01	CUSHION
*4-927-393-11	(M19)...INDIVIDUAL CARTON
*4-927-393-21	(M18)...INDIVIDUAL CARTON

<p><b>Note:</b> The components identified by mark △ or dotted line with mark △ are critical for safety. Replace only with part number specified.</p>	<p><b>Note:</b> Les composants identifiés par une marque △ sont critiques pour la sécurité. Ne les remplacer que par une pièce portant le numéro spécifié.</p>
--	--

# CDP-M18/M19

## SONY SERVICE MANUAL

Canadian Model  
CDP-M18

US Model  
Canadian Model  
E Model  
CDP-M19

### CORRECTION-1

Correct your service manual as shown below.

 : indicates corrected portion.

Page	INCORRECT	CORRECT
4	<b>E-F Balance Check</b> Procedure :  1. Connect test point TP (ADJ) to ground with lead wire.	<b>E-F Balance Check</b> Procedure :  1. Connect test point TP (ADJ) to ground and <u>TP (TES) to TP (VC)</u> with lead wire.  