

CDP-M205/M305

SERVICE MANUAL

AEP Model
UK Model
CDP-M205/M305
E Model
CDP-M305



Photo : CDP-M305

Model Name Using Similar Mechanism	CDP-M201/M301
CD Mechanism Type	CDM14-5BD29B
Base Unit Type	BU-5BD29B
Optical Pick-up Type	KSS-213B/K-N

SPECIFICATIONS

Compact disc player

Laser	Semiconductor laser ($\lambda = 780 \text{ nm}$) Emission duration: continuous
Laser output	Max 44.6 μW * * This output is the value measured at a distance of 200 mm from the objective lens surface on the Optical Pick-up block with 7 mm aperture.
Frequency response	2 Hz to 20 kHz $\pm 0.5 \text{ dB}$
Signal-to-noise ratio	More than 97 dB
Dynamic range	More than 90 dB
Harmonic distortion	Less than 0.007%
Channel separation	More than 86 dB

Outputs

	Jack type	Maximum output level	Load impedance
LINE OUT	Phono jacks	2 V (at 50 kilohms)	Over 10 kilohms

General

Power requirements

Where purchased	Power requirements
AEP, UK model :	220 V - 230 V AC, 50/60 Hz
E model :	110 V - 120 V or 220 V - 240 V AC, adjustable, 50/60 Hz

Power consumption	10 W
Dimensions (approx.)	355 × 95 × 310 mm (14 × 3 3/4 × 12 1/4 in.) (w/h/d) incl. projecting parts
Mass (approx.)	2.9 kg (6 lbs 6 oz)

Supplied accessories

Audio cord (2 phono plugs - 2 phono plugs) (1)
Remote commander (remote) (CDP-M305 only) (1)
Sony SUM-3 (NS) batteries (CDP-M305 only) (2)

Design and specifications are subject to change without notice.

COMPACT DISC PLAYER

SONY®



TABLE OF CONTENTS

Specifications	1
1. GENERAL	
Location and Function of Controls	3
2. SERVICING NOTE	4
3. DISASSEMBLY	5
4. ELECTRICAL ADJUSTMENTS	6
5. DIAGRAMS	
5-1. IC Pin Function	7
5-2. Printed Wiring Boards – BD Section –	11
5-3. Schematic Diagram – BD Section –	13
5-4. Schematic Diagram – Main Section –	17
5-5. Printed Wiring Boards – Main Section –	21
6. EXPLODED VIEWS	
6-1. Main Section	26
6-2. CD Block Section	27
6-3. Optical Pick-up Block Section (BU-5BD29B)	28
7. ELECTRICAL PARTS LIST	29

WARNING

To prevent fire or shock hazard, do not expose the unit to rain or moisture.

To avoid electrical shock, do not open the cabinet. Refer servicing to qualified personnel only.

Laser component in this product is capable of emitting radiation exceeding the limit for Class 1.

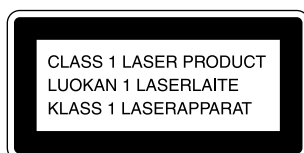

This appliance is classified as a CLASS 1 LASER product. The CLASS 1 LASER PRODUCT MARKING is located on the rear exterior.

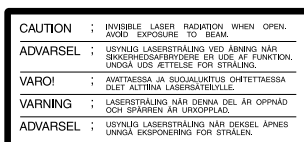

The following caution label is located inside of the unit.

MODEL IDENTIFICATION

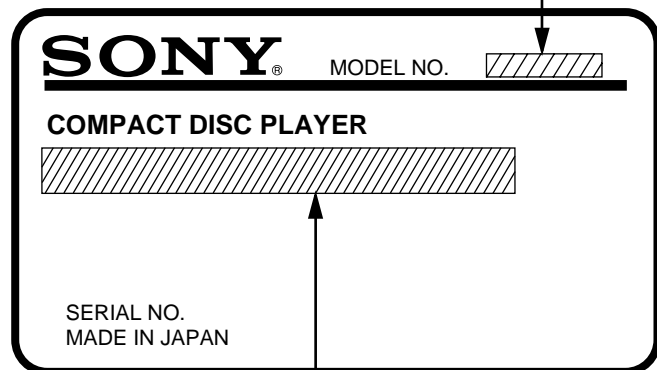

AEP, UK model :

AC : 220-230V~50/60Hz 10W

E model :

AC : 110-120V, 220-240V~ Adjustable 50/60Hz 10W

SAFETY-RELATED COMPONENT WARNING!!

COMPONENTS IDENTIFIED BY MARK \triangle OR DOTTED LINE WITH MARK \triangle ON THE SCHEMATIC DIAGRAMS AND IN THE PARTS LIST ARE CRITICAL TO SAFE OPERATION. REPLACE THESE COMPONENTS WITH SONY PARTS WHOSE PART NUMBERS APPEAR AS SHOWN IN THIS MANUAL OR IN SUPPLEMENTS PUBLISHED BY SONY.

SECTION 1 GENERAL

This section is extracted from instruction manual.

LOCATION AND FUNCTION OF CONTROLS

Front Panel

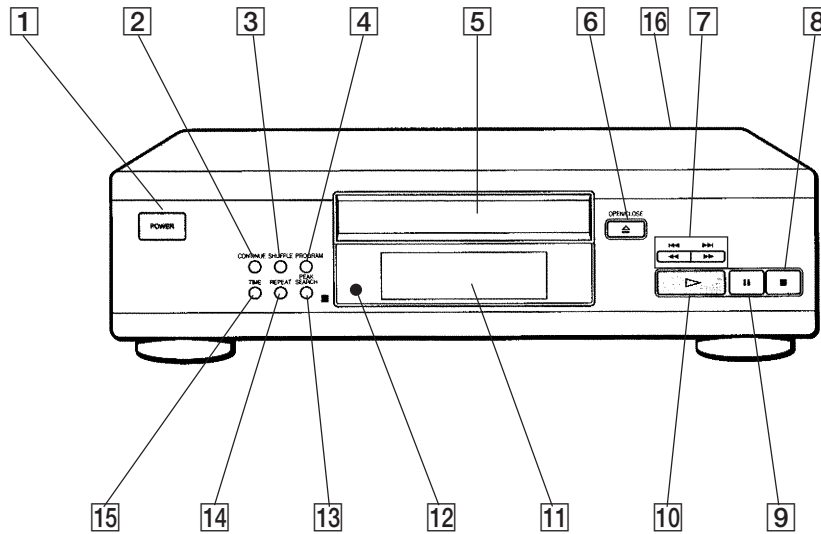

- | | |
|---|--|
| 1 POWER switch | 9 (PAUSE) button |
| 2 CONTINUE button | 10 ▷ (PLAY) button |
| 3 SHUFFLE button | 11 DISPLAY window |
| 4 PROGRAM button | 12 REMOTE sensor (CDP-M305 only) |
| 5 DISK tray | 13 PEAK SEARCH button |
| 6 OPEN/CLOSE button | 14 REPEAT button |
| 7 ◀◀/▶▶ (MANUAL SEARCH) buttons | 15 TIME button |
| 8 ■ (STOP) button | 16 VOLTAGE selector (Singapore model) |
| | 10 ◁ (PLAY) button |
| | 11 DISPLAY window |
| | 12 REMOTE sensor (CDP-M305 only) |
| | 13 PEAK SEARCH button |
| | 14 REPEAT button |
| | 15 TIME button |
| | 16 VOLTAGE selector (Singapore model) |

Remote Commander (CDP-M305 only)

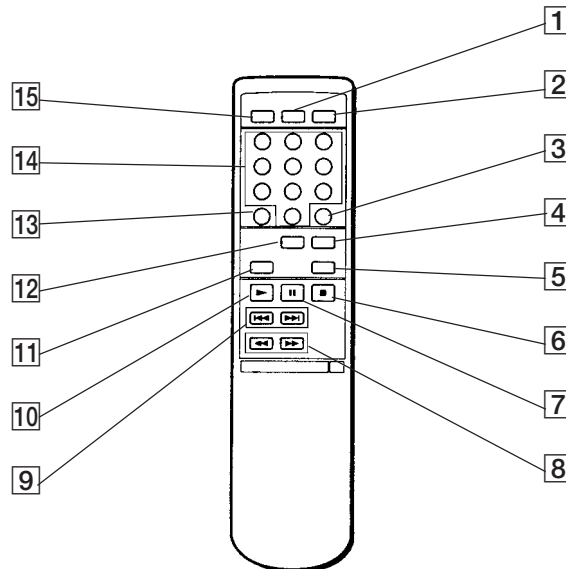

- | | |
|---|--|
| 1 SHUFFLE button | 9 ◀◀/▶▶ (AMS : AUTOMATIC MUSIC SENSOR) buttons |
| 2 PROGRAM button | 10 ▶ (PLAY) button |
| 3 CLEAR button | 11 REPEAT button |
| 4 CHECK button | 12 TIME button |
| 5 FADER button | 13 >10 (OVER 10) button |
| 6 ■ (STOP) button | 14 NUMBER buttons |
| 7 (PAUSE) button | 15 CONTINUE button |
| 8 ◀◀/▶▶ (MANUAL SEARCH) buttons | |

SECTION 2 SERVICING NOTE

HOW TO OPEN THE DISC TRAY WHEN POWER SWITCH TURNS OFF

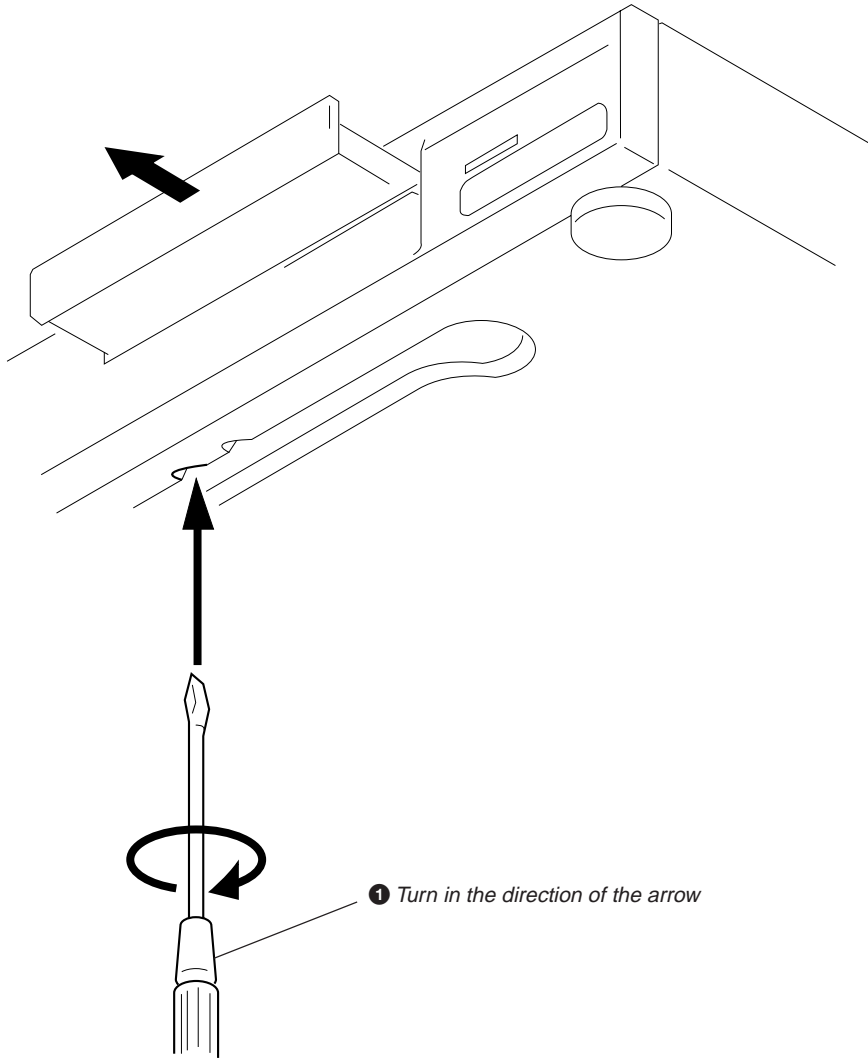

Caution : When you work, keep the set horizontal.

SECTION 3 DISASSEMBLY

Note : Follow the disassembly procedure in the numerical order given.

3-1. PANEL, FRONT REMOVAL

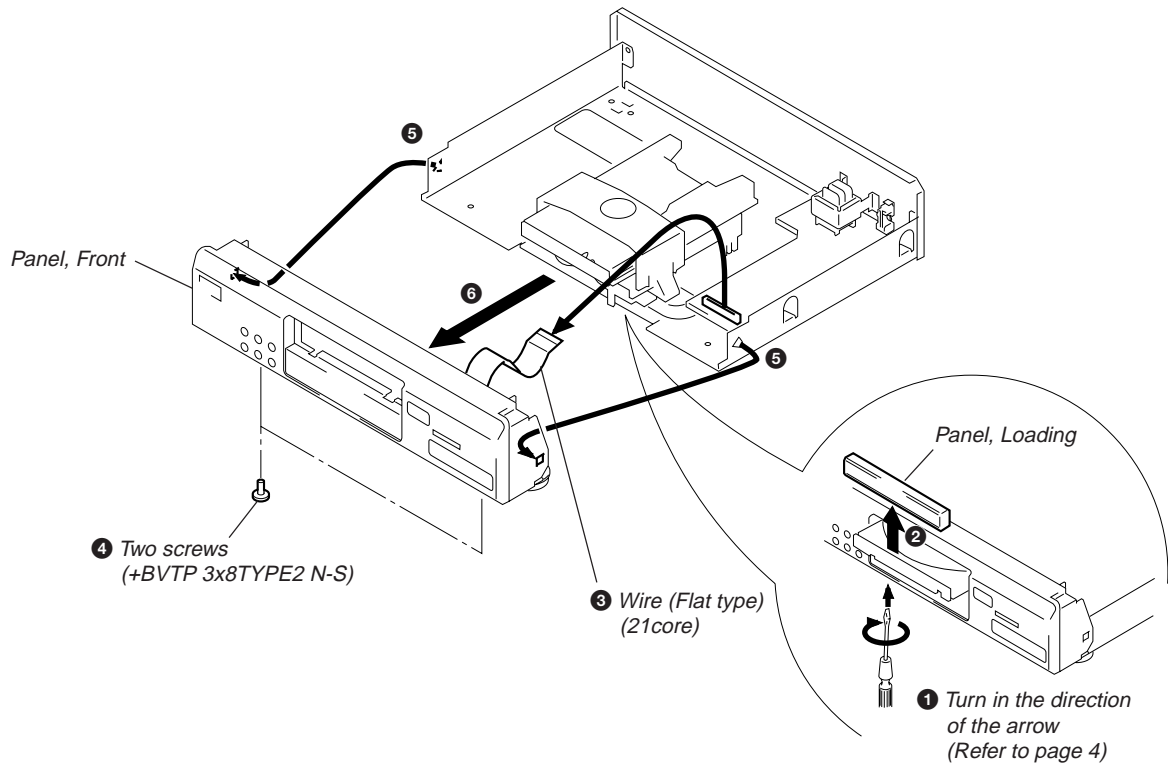

3-2. CD MECHANISM SECTION REMOVAL

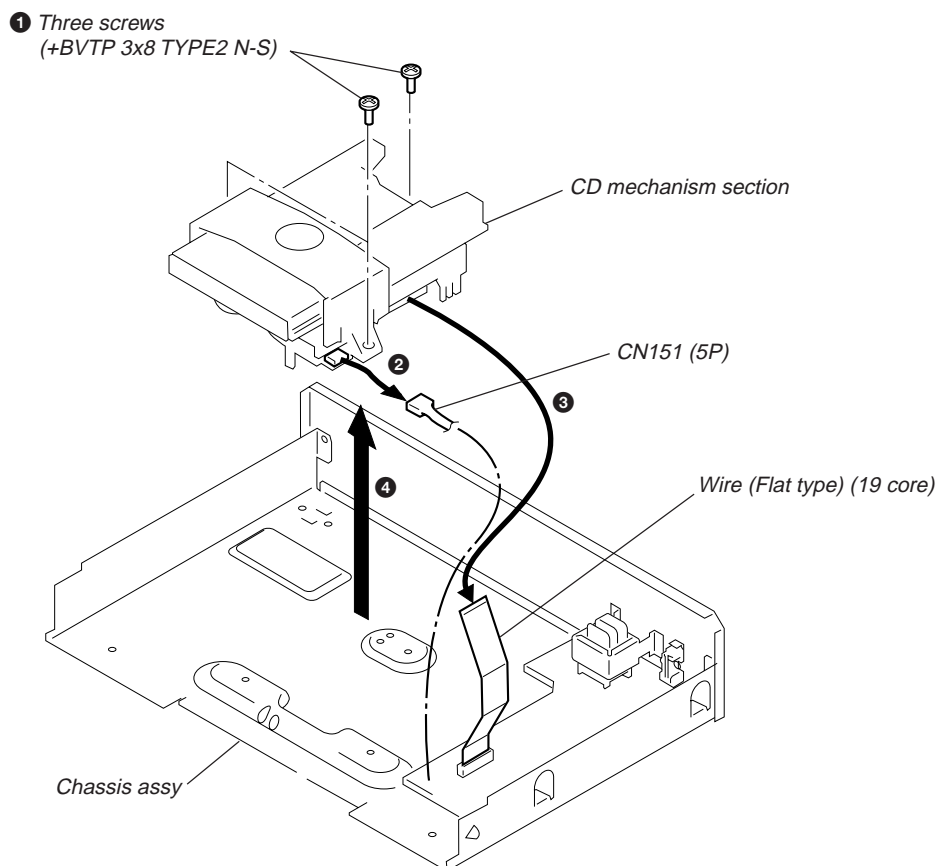

SECTION 4 ELECTRICAL ADJUSTMENTS

CD SECTION

Note:

1. CD Block is basically constructed to operate without adjustment. Therefore, check each item in order given.
2. Use YEDS-18 disc (3-702-101-01) unless otherwise indicated.
3. Use an oscilloscope with more than 10M impedance.
4. Clean the object lens by an applicator with neutral detergent when the signal level is low than specified value with the following checks.

S Curve Check

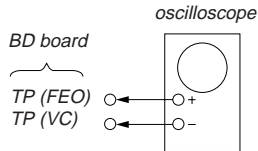

Procedure :

1. Connect oscilloscope to test point TP (FEO).
2. Connect between test point TP (FOK) and Ground by lead wire.
3. Turn Power switch on.
4. Put disc (YEDS-18) in and turned Power switch on again and actuate the focus search. (actuate the focus search when disc table is moving in and out.)
5. Check the oscilloscope waveform (S-curve) is symmetrical between A and B. And confirm peak to peak level within 3 ± 1 Vp-p.

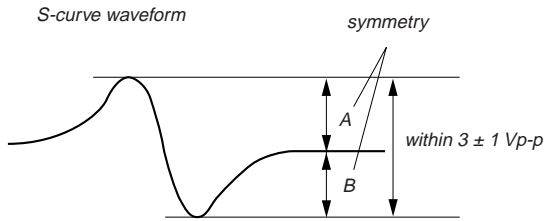

6. After check, remove the lead wire connected in step 2.
- Note:**
- Try to measure several times to make sure than the ratio of A : B or B : A is more than 10 : 7.
 - Take sweep time as long as possible and light up the brightness to obtain best waveform.

RF Level Check

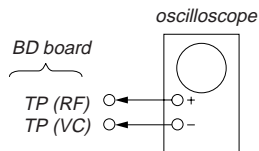

Procedure :

1. Connect oscilloscope to test point TP (RF) on BD board.
2. Turned Power switch on.
3. Put disc (YEDS-18) in and playback.
4. Confirm that oscilloscope waveform is clear and check RF signal level is correct or not.

Note: Clear RF signal waveform means that the shape “∩” can be clearly distinguished at the center of the waveform.

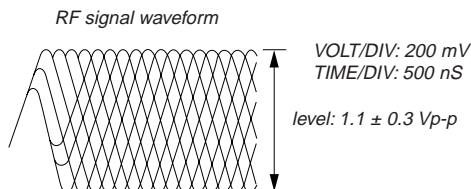

E-F Balance (1 Track Jump) check

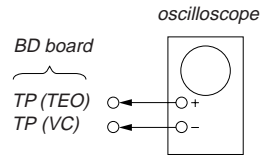

Procedure:

1. Connect oscilloscope to test point TP (TEO) on BD board.
 2. Turned Power switch on.
 3. Put disc (YEDS-18) in to play the number five track.
 4. Press the “|| (Pause)” button.
 5. Check the level B of the oscilloscope's waveform and the A (DC voltage) of the center of the Traverse waveform.
- Confirm the following:

- $A/B \times 100 = \text{less than } \pm 7 (\%)$

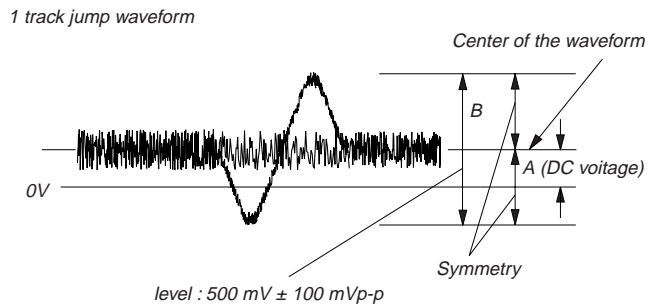

Adjustment Location:

[BD BOARD] (Conductor Side)

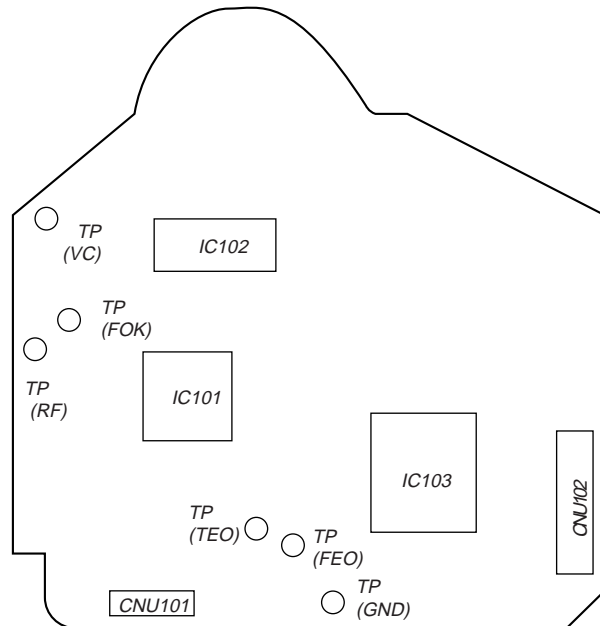

SECTION 5 DIAGRAMS

5-1. IC PIN FUNCTION

IC101 FOCUS/TRACKING/SLED SERVO RF AMP (CXA1992AR)

Pin No.	Pin name	I/O	Description.
1	FEO	O	Focus error amplifier output. Connected internally to the window comparator input for bias adjustment.
2	FEI	I	Focus error input.
3	FDFCT	I	Capacitor connection pin for defect time constant.
4	FGD	I	Ground this pin through a capacitor for cutting the focus servo high-frequency gain.
5	FLB	I	External time constant setting pin for boosting the focus servo low-frequency.
6	FE O	O	Focus drive output.
7	FE M	I	Focus amplifier inverted input.
8	SRCH	I	External time constant setting pin for generating focus search waveform.
9	TGU	I	External time constant setting pin for switching tracking high-frequency gain.
10	TG2	I	External time constant setting pin for switching tracking high-frequency gain.
11	FSET	I	Peak frequency setting pin for focus and tracking phase compensation amplifier.
12	TA M	I	Tracking amplifier inverted input.
13	TA O	O	Tracking drive output.
14	SL P	I	Sled amplifier non-inverted input.
15	SL M	I	Sled amplifier inverted input.
16	SL O	O	Sled drive output.
17	ISET	I	Connect an external capacitance to set the current which determines the Focus search, Track jump, and Sled kick heights.
18	VCC	I	Positive power supply.
19	LOCK	I	The sled overrun prevention circuit operates when this pin is Low (No pull-up resistance).
20	CLK	I	Serial data transfer clock input from CPU (No pull-up resistance).
21	XLT	I	Lach input from CPU (No pull-up resistance).
22	DATA	I	Serial data input from CPU (No pull-up resistance).
23	XRST	I	Reset input; resets at Low (No pull-up resistance).
24	C.OUT	O	Track number count signal output.
25	SENS1	O	Outputs FZC, DFCT1, TZC, BALH, TGH, FOH, ATSC, and others according to the command from CPU.
26	SENS2	O	Outputs DFCT2, MIRR, BALL, TGL, FOL, and others according to the command from CPU.
27	FOK	O	Focus OK comparator output.
28	CC2	I	Input for the defect bottom hold output with capacitance coupled.
29	CC1	O	Defect bottom hold output Connected internally to the interruption comparator input.
30	CB	I	Connection pin for defect bottom hold capacitor.
31	CP	I	Connection pin for MIRR hold capacitor MIRR comparator non-inverted input.
32	RF I	I	Input for the RF summing amplifier output with capacitance coupled.
33	RF O	O	RF summing amplifier output Eye-pattern check point.
34	RF M	I	RF summing amplifier inverted input. The RF amplifier gain is determined by the resistance connected between this pin and RFO pin .
35	RFTC	I	External time constant setting pin during RF level control.
36	LD	O	APC amplifier output.
37	PD	I	APC amplifier input.
38	PD1	I	RF I-V amplifier inverted input.
39	PD2	I	Connect these pins to the photo diode A+C and B+D pins.
40	FE BIAS	I	Bias adjustment of focus error amplifier Leave this pin open for automatic adjustment (not used).

Pin No.	Pin name	I/O	Description.
41	F	I	F I-V and E I-V amplifier inverted input.
42	E	I	Connect these pins to photo diodes F and E.
43	EI	-	I-V amplifier E gain adjustment (When not using automatic balance adjustment) (not used).
44	VEE	-	Negative power supply.
45	TEO	O	Tracking error amplifier output E-F signal is output.
46	LPFI	I	Comparator input for balance adjustment (Input from TEO through LPF).
47	TEI	I	Tracking error input.
48	ATSC	I	Window comparator input for ATSC detection.
49	TZC	I	Trackig zero-cross comparator input.
50	TDFCT	I	Capacitor connection pin for defect time constant.
51	VC	O	(VCC + VEE)/2 direct voltage output.
52	FZC	I	Focus zero-cross comparator input.

IC103 DIGITAL SIGNAL PROCESSOR (CXD2529Q)

Pin No.	Pin name	I/O	Description.
1	VDD	-	+5V power supply
2	VSS	-	Ground
3	LMUT	O	Lch "L" detection flog (Not used)
4	RMUT	O	Rch "L" detection flog (Not used)
5	ACDT	O	Test output (Not used)
6	CKOUT	O	Master clock divider output (Not used)
7	SQCK	I	Clock input for SQSO read out
8	SQSO	O	Serial output for Sub-Q 80bit
9	SENS	O	SENS signal output to CPU
10	DATA	I	Serial data input, supplied from CPU
11	XLAT	I	Latch input, supplied from CPU
12	CLOK	I	Serial data transfer clock input, supplied from CPU
13	SEIN	I	SENS input from IC101
14	CNIN	I	Numbers of track jump counted signal input
15	DATO	O	Serial data output to IC101
16	XLTO	O	Serial data latch output to IC101
17	CLKO	O	Serial data transfer clock output to IC101
18	SPOA	I	Micro computer demodulation interface (Input A)
19	SPOB	I	Micro computer demodulation interface (Input B)
20	SPOC	I	Micro computer demodulation interface (Input C)
21	SPOD	I	Micro computer demodulation interface (Input D)
22	XLON	O	Micro computer demodulation interface (Output) (not used)
23	FOK	I	Focus OK input
24	VDD	-	+5V power supply
25	VSS	-	Ground
26	MON	O	Output to control ON/OFF of spindle motor (Not used)
27	MDP	O	Output to control spindle motor servo
28	MDS	O	Output to control spindle motor servo (Not used)
29	LOCK	O	GFS is sampled by 460Hz
30	PWMI	I	Input to control the outside spindle motor
31	TES0	I	Test pin (Connected to ground)
32	TES1	I	Test pin (Connected to ground)
33	VPCO2	O	Charge-pump output (Not used)
34	VPCO1	O	Charge-pump output (Not used)
35	VCKI	I	VCO2 oscillator input (Not used)
36	V16M	O	VCO2 oscillator output (Not used)

Pin No.	Pin name	I/O	Description.
37	VCTL	I	VCO2 control voltage input
38	PCO	O	Charge-pump output to master PLL
39	FILO	O	Filter output to master PLL
40	FILI	I	Filter input for master PLL
41	AVSS	–	Analog ground
42	CLTV	I	Control voltage input for VCO
43	AVDD	–	Analog power supply
44	RF	I	EFM signal input
45	BIAS	I	Asymmetry circuit constant current input
46	ASYI	I	Asymmetry compare voltage input
47	ASYO	O	EFM full swing output (“L” =VSS, “H” =VDD)
48	ASYE	I	Asymmetry circuit ON/OFF (“L”=OFF, “H”=ON)
49	WDCK	O	D/A interface Word clock f=2fs (Not used)
50	LRCK	O	D/A interface LR clock output f=Fs
51	LRCKI	I	D/A interface LR clock input f=Fs
52	PCMD	O	D/A interface Serial data output
53	PCMDI	I	D/A interface Serial data input
54	BCK	O	D/A interface Bit clock output
55	BCKI	I	D/A interface Bit clock input
56	VSS	–	Ground
57	VDD	–	+5V power supply
58	GTOP	–	Not used
59	XUGF	–	Not used
60	XPLCK	O	EFM decoder PLL clock output
61	GFS	O	“H” Playback EFM sync and interpolation protection timing much
62	RFCK	O	Read Frame Clock signal output
63	C2PO	–	Not used
64	XRAOF	O	Internal RAM overflow detection signal output (Not used)
65	MNT3	–	Not used
66	MNT1	–	Not used
67	MNT0	–	Not used
68	XTSL	–	Not used
69	FSTT	O	2/3 divider output (Not used)
70	C4M	O	4.2336MHz output(Not used)
71	DOUT	O	Digital audio signal output
72	EMPH	O	Playback disc output in emphasis mode
73	EMPHI	I	“H” =Input when de-emphasis ON
74	WFCK	O	Write Frame Clock signal output
75	SCOR	O	Sub-code sync output
76	SBSO	O	Sub-P through Sub-W serial output
77	EXCK	I	Clock input for SBSO read-out
78	VSS	–	Ground
79	VDD	–	+5V power supply
80	SYSM	I	System mute input (Connected to ground)
81	—	–	Not used
82	AVSS	–	Analog ground
83	AVDD	–	Analog power supply
84	AOUT1	O	Lch analog output
85	AIN1	I	Lch opamp input
86	LOUT1	O	Lch line output
87	AVSS	–	Analog ground
88	XVDD	–	Master clock power supply
89	XTAI	I	X’tal oscillator circuit input
90	XTAO	O	X’tal oscillator circuit output

Pin No.	Pin name	I/O	Description.
91	XVSS	–	Master clock ground
92	AVSS	–	Analog ground
93	LOUT2	O	Rch line output
94	AIN2	I	Rch opamp input
95	AOUT2	O	Rch analog output
96	AVDD	–	Analog power supply
97	AVSS	–	Analog ground
98	—	–	Not used
99	—	–	Not used
100	XRST	I	Sysyem reset input

IC501 SYSTEM CONTROL (CXP82612-028Q)

Pin No.	Pin name	I/O	Description
1	GND	–	Ground.
2	RMIN	I	Remote control signal input.
3	GND	–	Ground.
4–7	NC	–	Not used (Open).
8	CLK	O	Serial clock output.
9	SENSE	I	Sense signal input from IC103 (CXD2529Q).
10	DATA	O	Serial data output.
11	SQCK	O	Sub Q clock output.
12	SUBQ	I	Sub Q data input.
13	SENSE2	I	Sense signal input from IC101 (CXA1992AR)
14	NC	–	Not used (Open).
15	XLT	O	Serial latch output.
16–19	NC	–	Not used (Open).
20	LD OUT	O	Loadin motor control.
21	LD IN	O	Loadin motor control.
22	KEY 0	I	Key input 0.
23	KEY1	I	Key input 1.
24–27	NC	–	Not used (Open).
28	ADJ/AFADJ	I	Test mode terminal.
29	IN/OUT SW	I	CD tray IN/OUT switch.
30	RST	I	System reset terminal.
31	EXTAL	O	System oscillator (4.0 MHz).
32	XTAL	I	System oscillator (4.0 MHz).
33	VSS	–	Ground.
34–41	NC	–	Not used (Open).
42–62	S21–S1	O	FL segment signal output.
63–67	1G–5G	O	FL grid signal output.
68	NC	–	Not used (Open).
69, 70	6G,7G	O	FL grid signal output.
71	VFDP	–	Pull down voltage (– 30V).
72	VDD	–	Power supply (+5V).
73,74	GND	–	Ground.
75	VDD	–	Power supply (+5V).
76,77	NC	–	Not used (Open).
78	SCOR	I	Sub code data request signal input.
79, 80	GND	–	Ground.

5-2. PRINTED WIRING BOARDS – BD SECTION –

● SEMICONDUCTOR LOCATION

Ref. No.	Location
IC101	C-6
IC102	B-6
IC103	D-8
Q101	C-4

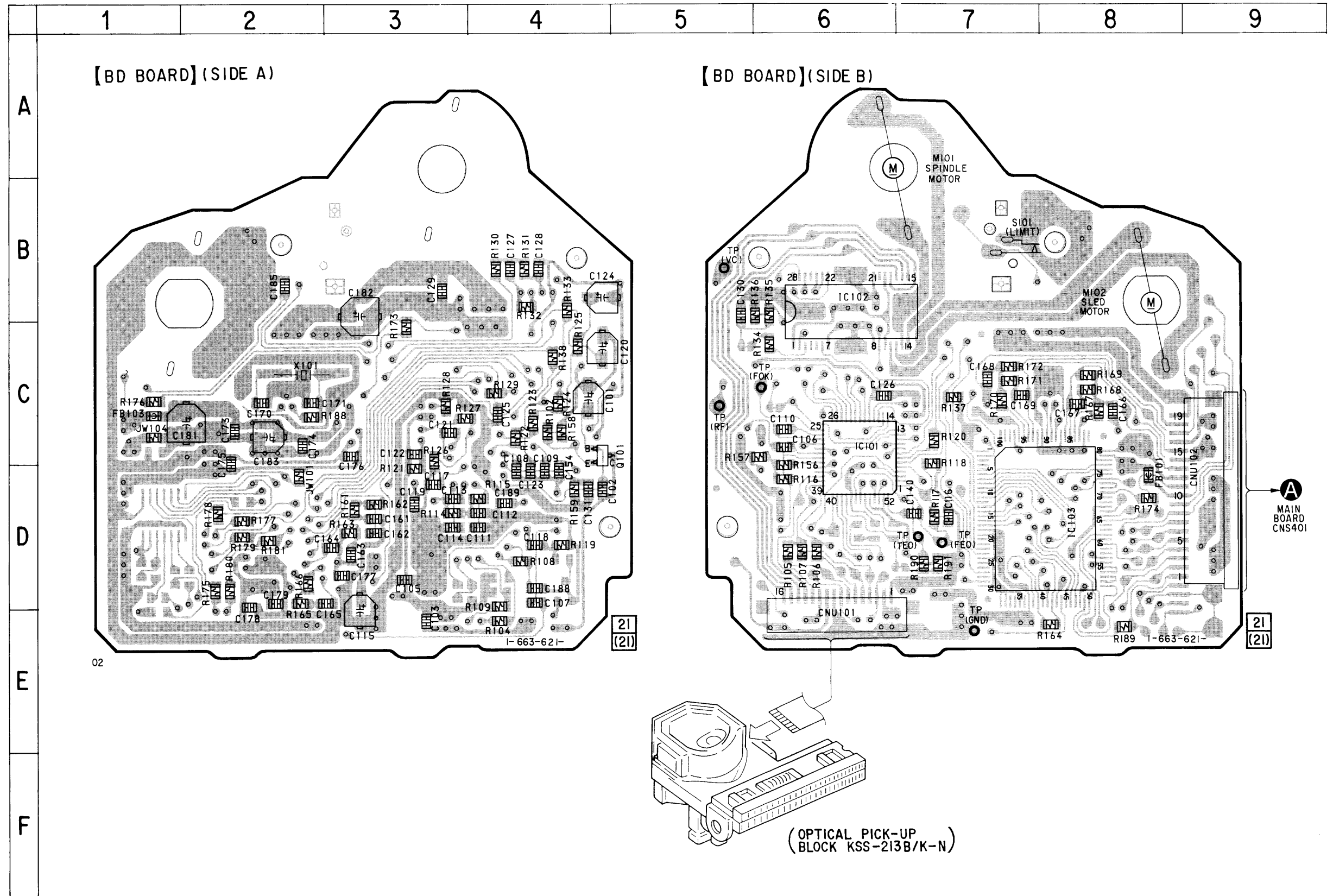

Note:

- : parts extracted from the component side.
- : Through hole.
- ▨ : Pattern from the side which enables seeing.
(The other layers' patterns are not indicated)

Caution :

Pattern face side : Parts on the pattern face side seen from (Conductor Side) the pattern face are indicated.
Parts face side : Parts on the parts face side seen from the (Component side) parts face are indicated.

5-3. SCHEMATIC DIAGRAM - BD SECTION - Refer to page 24 for IC Block Diagrams.

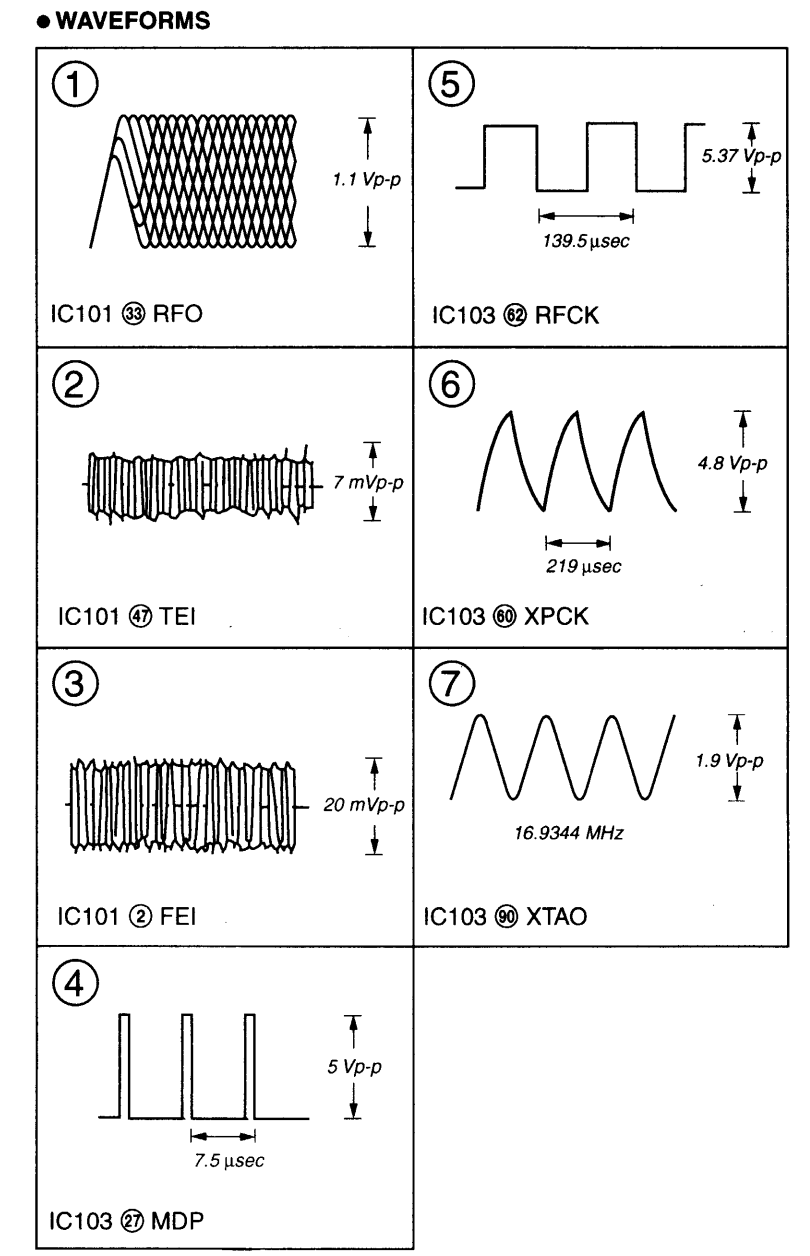
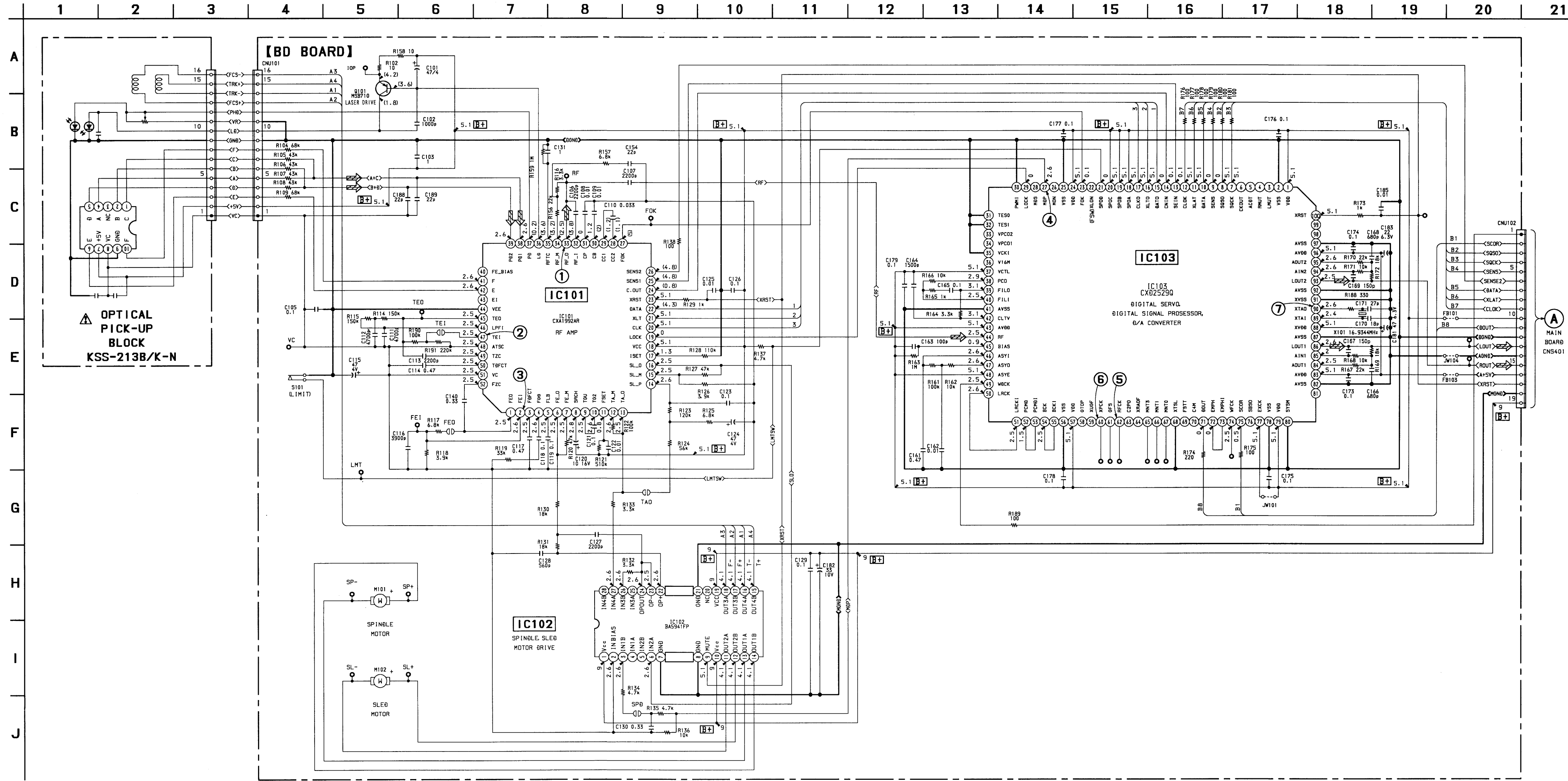

Note :

- All capacitors are in µF unless otherwise noted. pF: µµF
- 50WV or less are not indicated except for electrolytics and tantalums.
- All resistors are in Ω and 1/4 W or less unless otherwise specified.
- % : indicates tolerance.
- B+** : B+ Line
- Voltage and waveforms are dc with respect to ground under no-signal conditions.
- no mark : STOP
- () : PLAY
- Voltagess are taken with a VOM (Input impedance 10MΩ). Voltage variations may be noted due to normal production tolerances.
- Waveforms are taken with an oscilloscope. Voltage variations may be noted due to normal production tolerances.
- Circled numbers refer to waveforms.
- Signal path.
- CD

WAVEFORM

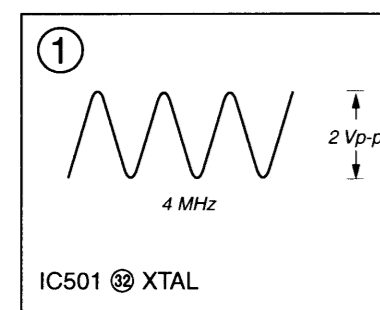

- Note:**
- All capacitors are in μF unless otherwise noted. pF : μF 50WV or less are not indicated except for electrolytics and tantalums.
 - All resistors are in Ω and $\frac{1}{4}\text{W}$ or less unless otherwise specified.
 - % : indicates tolerance.
 - Δ : internal component.
 - B+** : B+ Line
 - B-** : B- Line
 - Voltage and waveforms are dc with respect to ground under no-signal conditions.
 - no mark : STOP
 - () : PLAY
 - Voltagess are taken with a VOM (Input impedance 10M Ω).
 - Voltage variations may be noted due to normal production tolerances.
 - Waveforms are taken with an oscilloscope.
 - Voltage variations may be noted due to normal production tolerances.
 - Circled numbers refer to waveforms.
 - Signal path
 - \square : CD

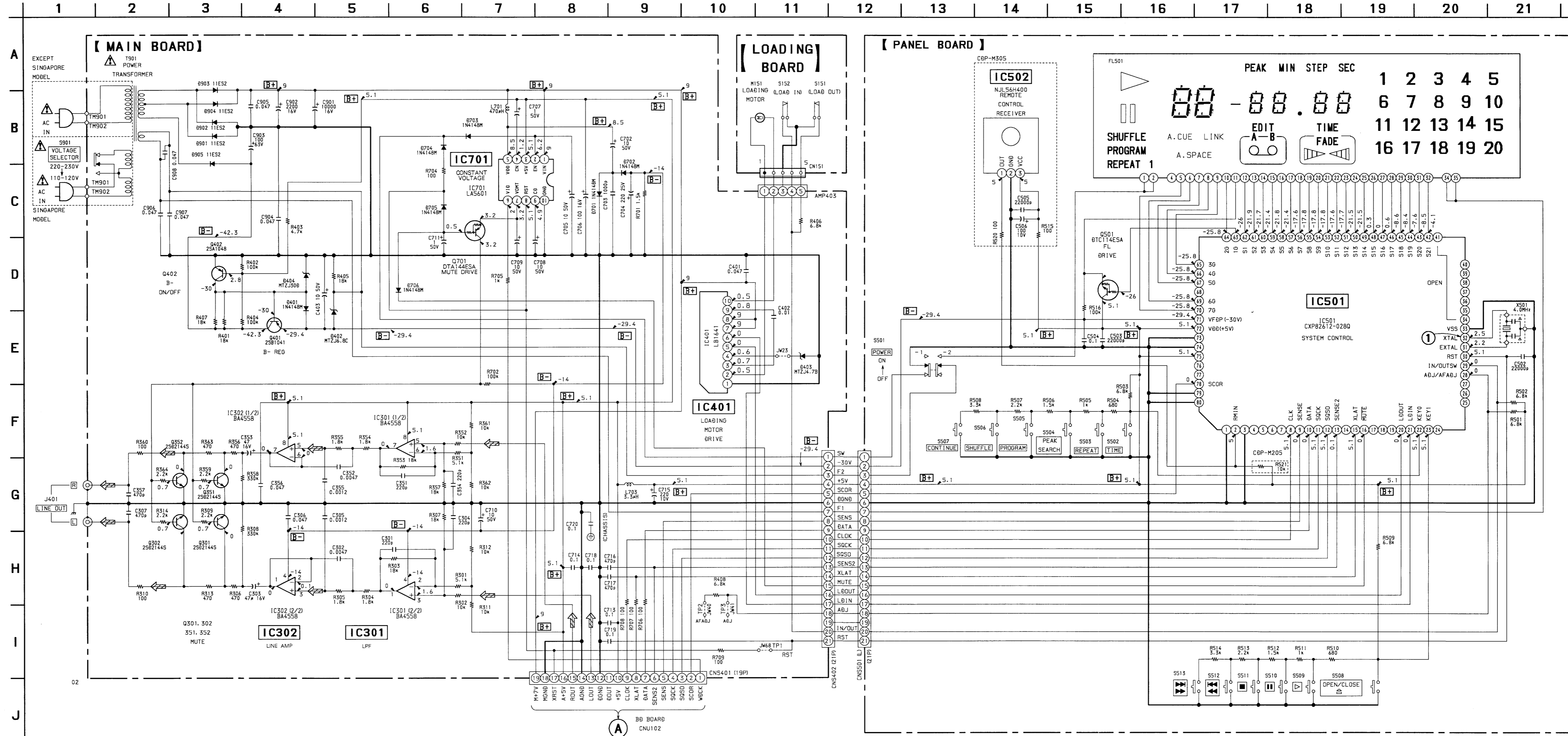

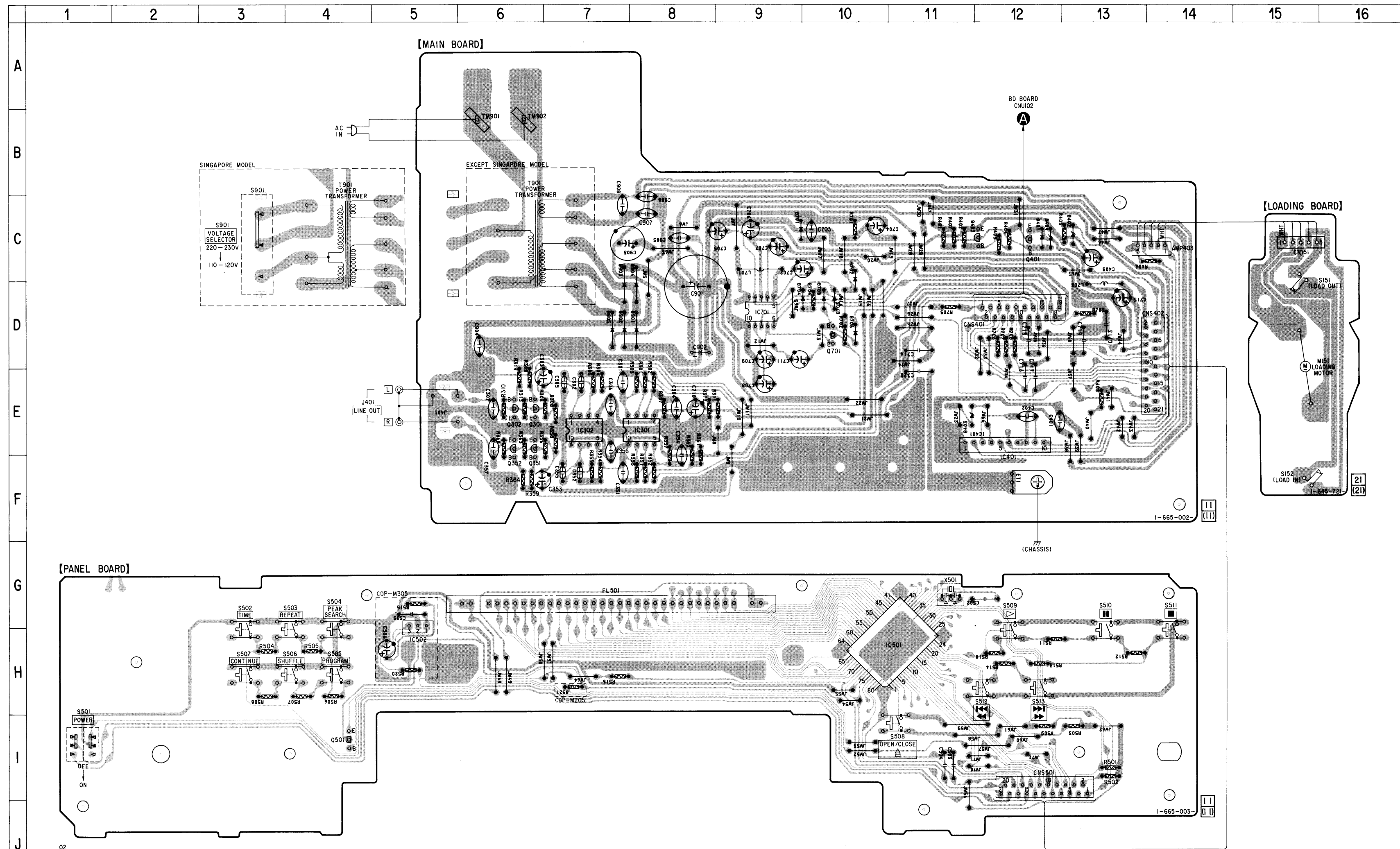

● SEMICONDUCTOR LOCATION

Ref. No.	Location
D401	C-12
D402	C-13
D403	E-11
D404	C-12
D701	C-9
D702	C-10
D703	D-10
D704	D-9
D705	D-10
D706	D-10
D901	D-8
D902	D-7
D903	C-7
D904	C-8
D905	D-7
IC301	E-8
IC302	E-7
IC401	E-12
IC501	H-10
IC502	G-5
IC701	D-9
Q301	E-6
Q302	E-6
Q351	E-6
Q352	E-6
Q401	C-12
Q402	C-11
Q501	I-4
Q701	D-10

Note:
 • ○ : parts extracted from the component side.
 • ■ : Pattern on the side which is seen.

● IC BLOCK DIAGRAMS

IC102 BA5941FP

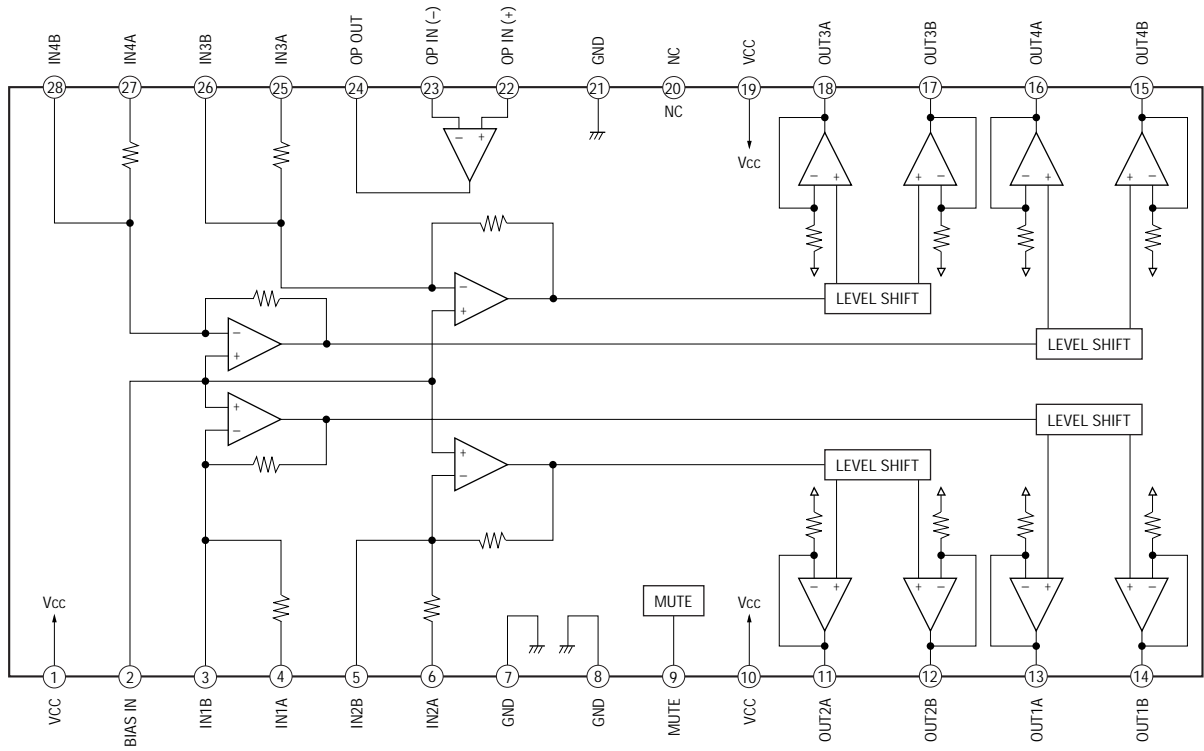

IC103 CXD2529Q

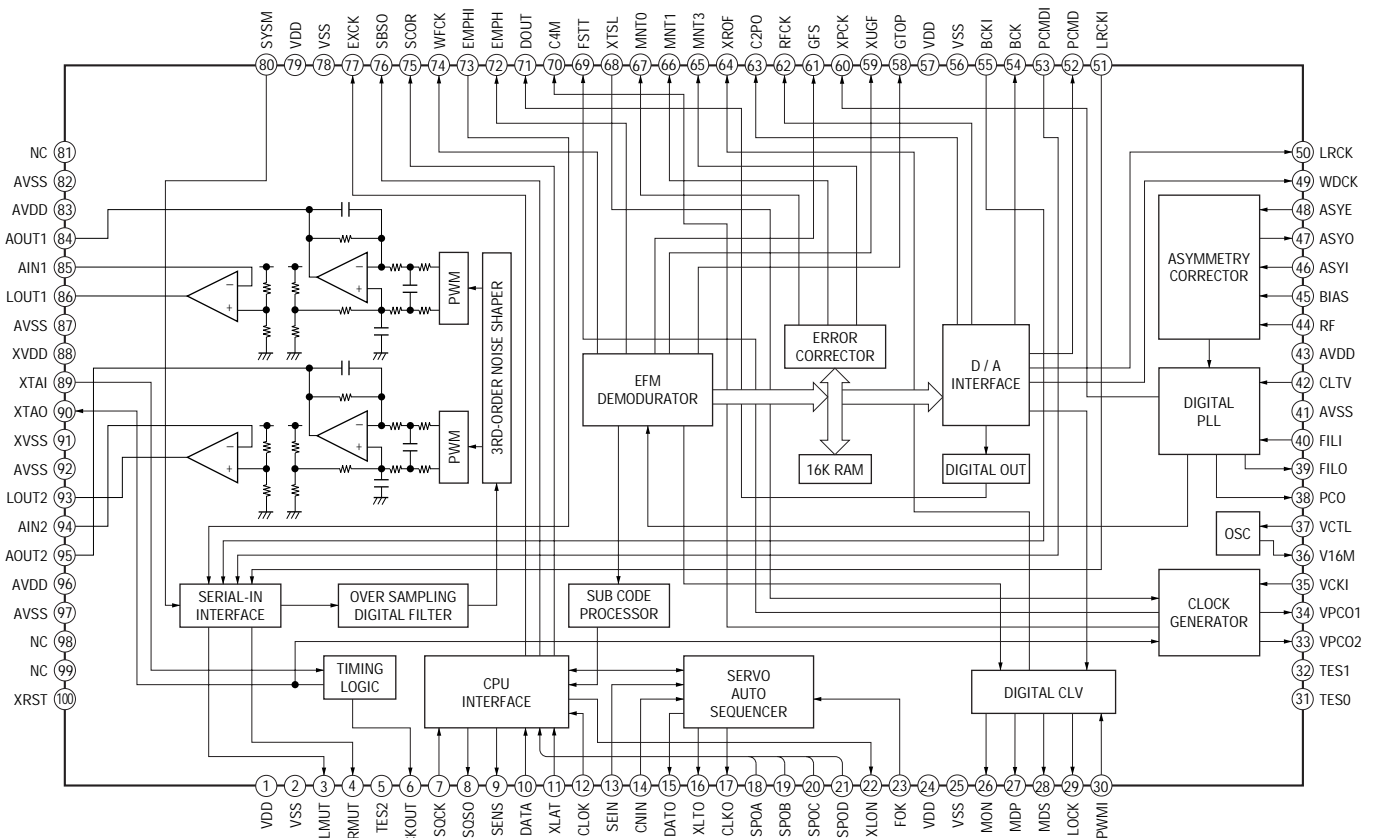

IC101 CXA1992AR

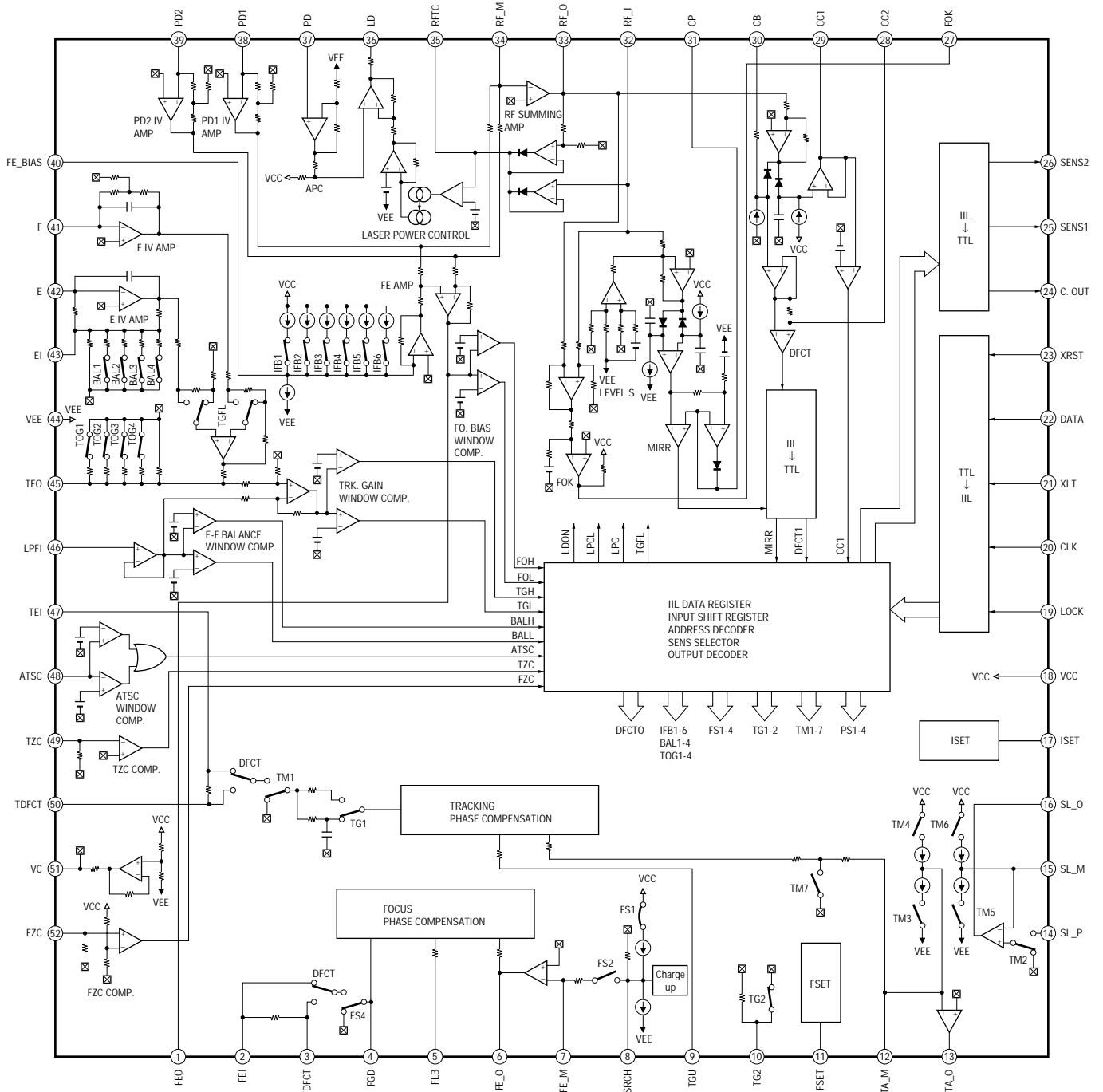

IC401 LB1641

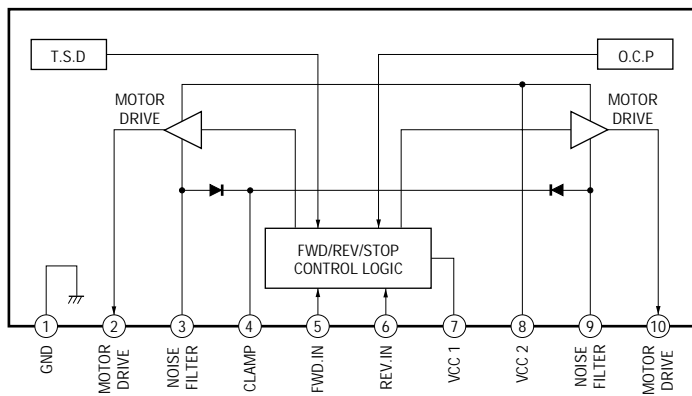

SECTION 6 EXPLODED VIEWS

NOTE :

- -XX, -X mean standardized parts, so they may have some difference from the original one.
- Items marked “*” are not stocked since they are seldom required for routine service. Some delay should be anticipated when ordering these items.
- The mechanical parts with no reference number in the exploded views are not supplied.
- Hardware (# mark) list and accessories and packing materials are given in the last of this parts list.

The components identified by mark Δ or dotted line with mark Δ are critical for safety.
Replace only with part number specified.

6-1. MAIN SECTION

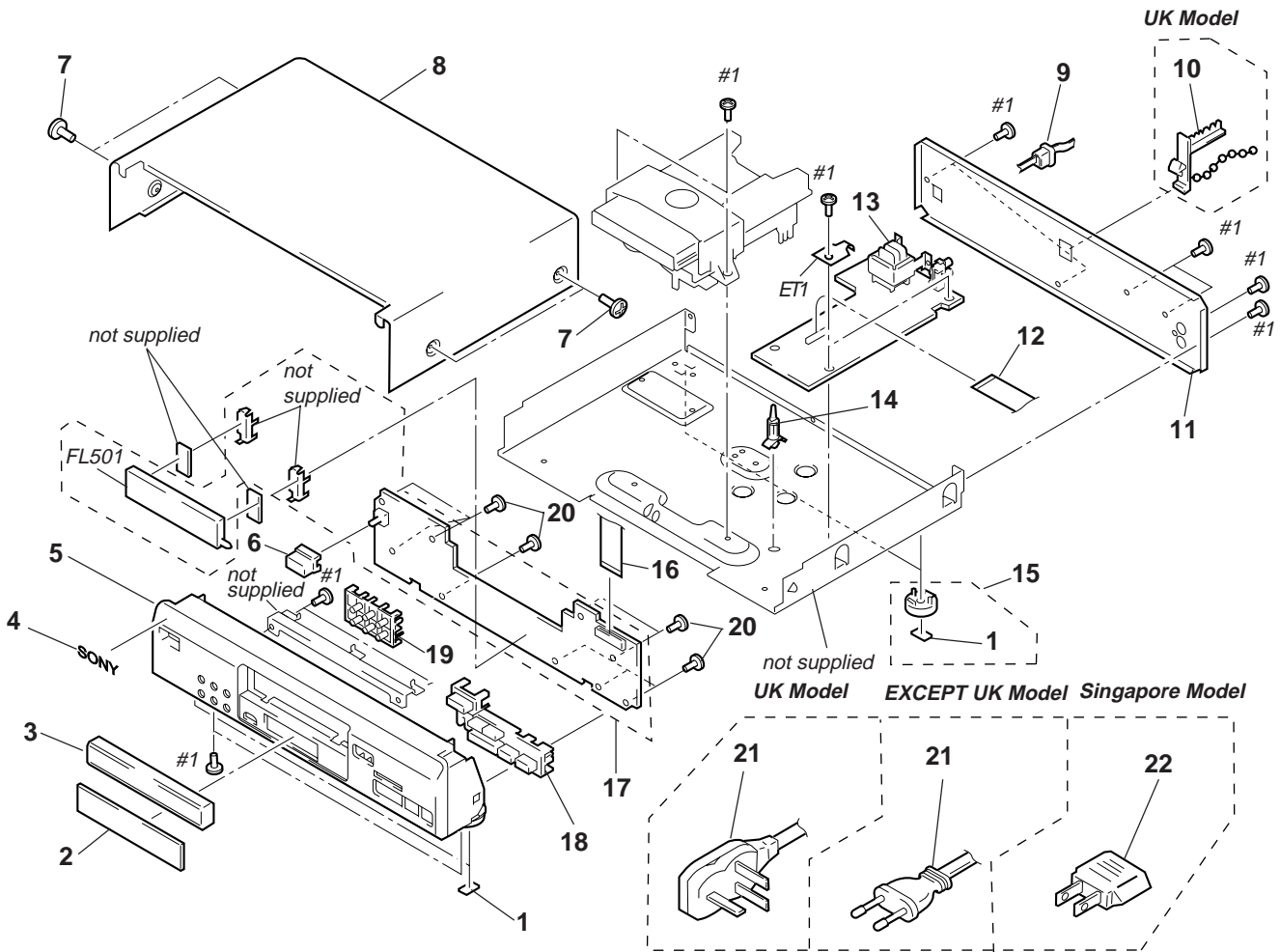

Ref. No.	Part No.	Description	Remark
* 1	4-978-398-21	CUSHION	
2	4-977-597-01	PLATE, INDICATION	
3	4-977-588-01	PANEL, LOADING (M305)	
3	4-977-588-11	PANEL, LOADING (M205)	
4	3-008-600-01	EMBLEM (5-AR), SONY	
5	4-988-717-01	PANEL, FRONT (M305)	
5	4-988-717-11	PANEL, FRONT (M205)	
6	4-977-589-01	BUTTON (POWER)	
7	3-704-366-31	SCREW (CASE) (M3X6)	
* 8	4-989-107-11	CASE	
9	4-966-267-11	BUSHING (FBS001), CORD	
10	4-956-370-02	BAND, PLUG FIXED (UK)	
* 11	4-988-718-01	PANEL, BACK (M305:AEP)	
* 11	4-988-718-11	PANEL, BACK (M305:UK)	
* 11	4-988-718-21	PANEL, BACK (M305:Singapore)	
* 11	4-988-718-31	PANEL, BACK (M205:AEP)	
* 11	4-988-718-41	PANEL, BACK (M205:UK)	
12	1-773-109-11	WIRE (FLAT TYPE) (19 CORE)	

Ref. No.	Part No.	Description	Remark
* 13	A-4699-608-A	MAIN BOARD, COMPLETE	
			(EXCEPT Singapore)
* 13	A-4699-609-A	MAIN BOARD, COMPLETE (Singapore)	
* 14	4-954-051-51	HOLDER, PC BOARD	
15	X-3371-435-1	FOOT (SMALL) ASSY	
16	1-773-147-11	WIRE (FLAT TYPE) (21 CORE)	
* 17	A-4699-606-A	PANEL BOARD, COMPLETE (M205)	
* 17	A-4699-607-A	PANEL BOARD, COMPLETE (M305)	
18	4-977-583-61	BUTTON (PLAY)	
19	4-977-584-11	BUTTON (MODE) (M305)	
19	4-977-584-21	BUTTON (MODE) (M205)	
20	4-951-620-01	SCREW (2.6X8), +BVTP	
Δ 21	1-751-535-11	CORD, POWER (UK)	
Δ 21	1-777-447-11	CORD, POWER (EXCEPT UK)	
Δ 22	1-569-008-21	ADAPTOR, CONVERSION 2P (Singapore)	
ET1	1-537-771-21	TERMINAL BOARD, GROUND	
FL501	1-517-297-11	INDICATOR TUBE, FLUORESCENT	

6-2. CD BLOCK SECTION

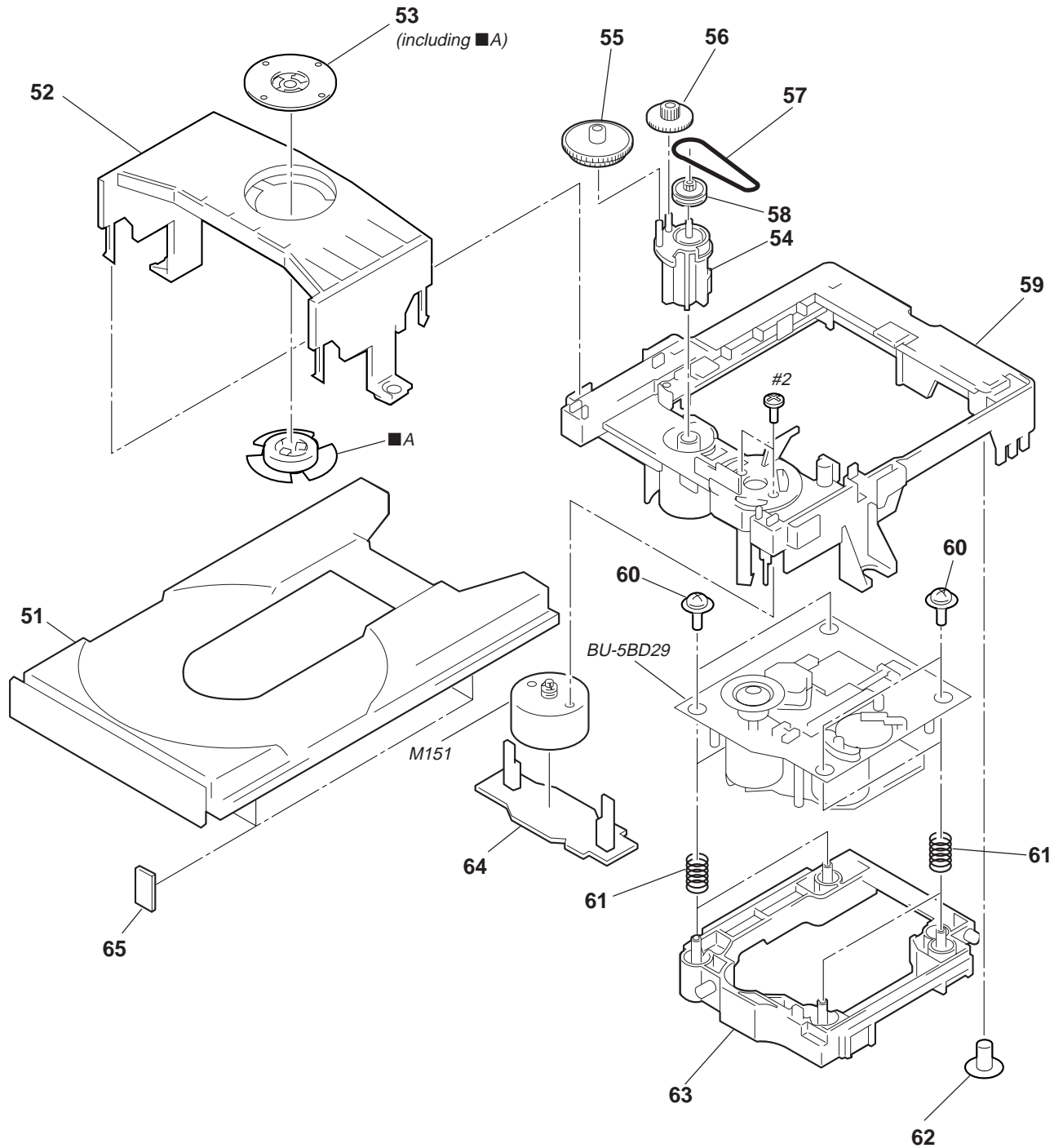

Ref. No.	Part No.	Description	Remark	Ref. No.	Part No.	Description	Remark
51	4-933-112-01	TABLE, DISC		60	4-933-134-01	SCREW (+PTPWH M2.6X6)	
52	4-933-110-41	HOLDER (MG)		61	4-959-996-01	SPRING (932), COMPRESSION	
* 53	1-452-879-11	MAGNET		* 62	4-917-583-21	BRACKET, YOKE	
54	4-933-109-01	CAM		63	4-933-129-32	HOLDER (BU)	
55	4-933-107-01	GEAR (PL)		* 64	1-645-721-11	LOADING BOARD	
				65	4-925-315-31	DAMPER	
56	4-967-268-01	GEAR (C)		M151	A-4660-692-A	MOTOR (L) ASSY (LOADING)	
57	4-927-649-01	BELT					
58	4-927-651-01	PULLEY (S)					
59	4-933-111-41	CHASSIS (MD)					

6-3. OPTICAL PICK-UP BLOCK SECTION (BU-5BD29B)

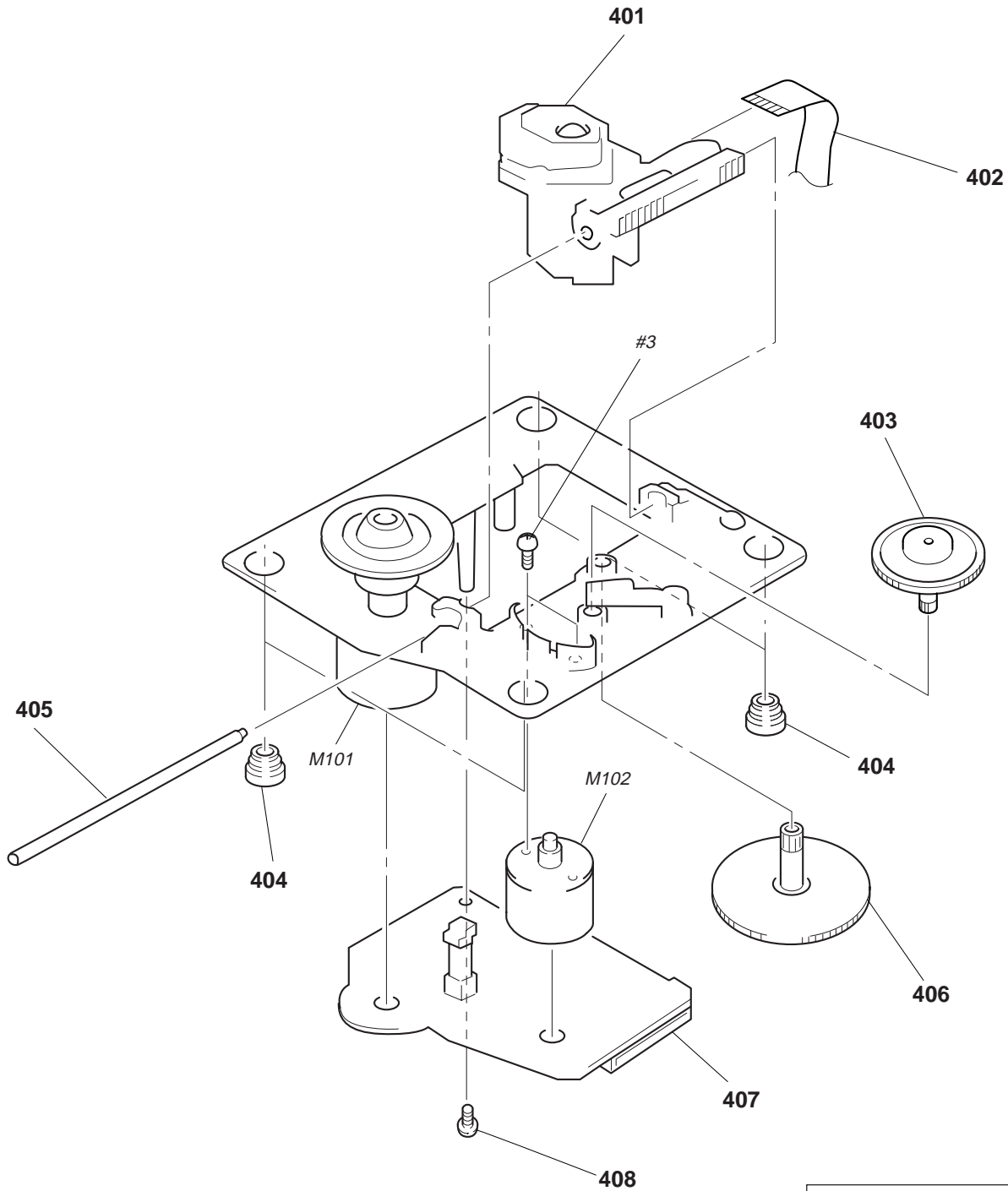

The components identified by mark △ or dotted line with mark △ are critical for safety.
Replace only with part number specified.

Ref. No.	Part No.	Description	Remark	Ref. No.	Part No.	Description	Remark
△ 401	8-848-367-11	OPTICAL PICK-UP KSS-213B/K-N		406	4-917-564-01	GEAR (P), FLATNESS	
402	1-769-069-11	WIRE (FLAT TYPE) (16 CORE)		* 407	A-4699-666-A	BD BOARD, COMPLETE	
403	4-917-567-01	GEAR (M)		408	4-951-620-01	SCREW (2.6X8), +BVT	
404	4-951-940-01	INSULATOR (BU)		M101	X-4917-523-3	MOTOR ASSY (SPINDLE)	
405	4-917-565-01	SHAFT, SLED		M102	X-4917-504-1	MOTOR ASSY (SLED)	

SECTION 7 ELECTRICAL PARTS LIST

BD

NOTE :

- Due to standardization, replacements in the parts list may be different from the parts specified in the diagrams or the components used on the set.
- -XX, -X mean standardized parts, so they may have some difference from the original one.
- RESISTORS
All resistors are in ohms
METAL : Metal-film resistor
METAL OXIDE :Metal oxide-film resistor
F : nonflammable
- Items marked “ * ” are not stocked since they are seldom required for routine service. Some delay should be anticipated when ordering these items.

● SEMICONDUCTORS

In each case, u : μ , for example :
uA..... : μ A..... , uPA..... : μ PA.....
uPB..... : μ PB..... , uPC..... : μ PC.....
uPD..... : μ PD.....

● CAPACITORS

uF : μ F

● COILS

uH : μ H

The components identified by mark Δ or dotted line with mark Δ are critical for safety.
Replace only with part number specified.

When indicating parts by reference number, please include the board.

Ref. No.	Part No.	Description	Remark	Ref. No.	Part No.	Description	Remark
*	A-4699-666-A	BD BOARD, COMPLETE *****		C171	1-163-237-11	CERAMIC CHIP 27PF	5%
		< CAPACITOR >		C173	1-163-038-91	CERAMIC CHIP 0.1uF	25V
C101	1-126-607-11	ELECT CHIP 47uF	20% 4V	C174	1-163-038-91	CERAMIC CHIP 0.1uF	25V
C102	1-163-141-00	CERAMIC CHIP 0.001uF	5% 50V	C175	1-163-038-91	CERAMIC CHIP 0.1uF	25V
C103	1-164-346-11	CERAMIC CHIP 1uF	16V	C176	1-163-038-91	CERAMIC CHIP 0.1uF	25V
C105	1-163-038-91	CERAMIC CHIP 0.1uF	25V	C177	1-163-038-91	CERAMIC CHIP 0.1uF	25V
C106	1-164-161-11	CERAMIC CHIP 0.0022uF	10% 100V	C178	1-163-038-91	CERAMIC CHIP 0.1uF	25V
C107	1-164-161-11	CERAMIC CHIP 0.0022uF	10% 100V	C179	1-163-038-91	CERAMIC CHIP 0.1uF	25V
C108	1-164-232-11	CERAMIC CHIP 0.01uF	50V	C181	1-126-205-11	ELECT CHIP 47uF	20% 6.3V
C109	1-164-232-11	CERAMIC CHIP 0.01uF	50V	C182	1-126-393-11	ELECT 33uF	20% 10V
C110	1-163-989-11	CERAMIC CHIP 0.033uF	10% 25V	C183	1-124-778-00	ELECT CHIP 22uF	20% 6.3V
C111	1-163-017-00	CERAMIC CHIP 0.0047uF	5% 50V	C185	1-164-232-11	CERAMIC CHIP 0.01uF	50V
C112	1-163-017-00	CERAMIC CHIP 0.0047uF	5% 50V	C188	1-163-235-11	CERAMIC CHIP 22PF	5% 50V
C113	1-164-161-11	CERAMIC CHIP 0.0022uF	10% 100V	C189	1-163-235-11	CERAMIC CHIP 22PF	5% 50V
C114	1-164-005-11	CERAMIC CHIP 0.47uF	25V			< CONNECTOR >	
C115	1-126-607-11	ELECT CHIP 47uF	20% 4V	CNU101	1-770-014-11	CONNECTOR, FFC/FPC 16P	
C116	1-163-016-00	CERAMIC CHIP 0.0039uF	10% 50V	CNU102	1-778-874-11	CONNECTOR, FFC (LIF (NON-ZIF)) 19P	
C117	1-164-005-11	CERAMIC CHIP 0.47uF	25V			< FERRITE BEAD >	
C118	1-164-004-11	CERAMIC CHIP 0.1uF	10% 25V	FB101	1-414-234-11	INDUCTOR, FERRITE BEAD	
C119	1-163-038-91	CERAMIC CHIP 0.1uF	25V	FB103	1-414-234-11	INDUCTOR, FERRITE BEAD	
C120	1-124-779-00	ELECT CHIP 10uF	20% 16V			< IC >	
C121	1-163-038-91	CERAMIC CHIP 0.1uF	25V	IC101	8-752-080-62	IC CXA1992AR	
C122	1-164-232-11	CERAMIC CHIP 0.01uF	50V	IC102	8-759-429-32	IC BA5941FP-E2	
C123	1-163-038-91	CERAMIC CHIP 0.1uF	25V	IC103	8-752-380-64	IC CXD2529Q	
C124	1-126-607-11	ELECT CHIP 47uF	20% 4V			< JUMPER RESISTOR >	
C125	1-164-232-11	CERAMIC CHIP 0.01uF	50V	JW101	1-216-295-00	METAL CHIP 0	5% 1/10W
C126	1-163-038-91	CERAMIC CHIP 0.1uF	25V	JW104	1-216-295-00	METAL CHIP 0	5% 1/10W
C127	1-164-161-11	CERAMIC CHIP 0.0022uF	10% 100V			< TRANSISTOR >	
C128	1-163-135-00	CERAMIC CHIP 560PF	5% 50V	Q101	8-729-010-08	TRANSISTOR MSB710-R	
C129	1-163-038-91	CERAMIC CHIP 0.1uF	25V			< RESISTOR >	
C130	1-164-336-11	CERAMIC CHIP 0.33uF	25V	R102	1-216-001-00	METAL CHIP 10	5% 1/10W
C131	1-164-346-11	CERAMIC CHIP 1uF	16V	R104	1-216-093-00	METAL CHIP 68K	5% 1/10W
C140	1-110-501-11	CERAMIC CHIP 0.33uF	10% 16V	R105	1-216-088-00	METAL CHIP 43K	5% 1/10W
C154	1-163-235-11	CERAMIC CHIP 22PF	5% 50V	R106	1-216-088-00	METAL CHIP 43K	5% 1/10W
C161	1-164-005-11	CERAMIC CHIP 0.47uF	25V	R107	1-216-088-00	METAL CHIP 43K	5% 1/10W
C162	1-164-232-11	CERAMIC CHIP 0.01uF	50V	R108	1-216-088-00	METAL CHIP 43K	5% 1/10W
C163	1-163-117-00	CERAMIC CHIP 100PF	5% 50V	R109	1-216-093-00	METAL CHIP 68K	5% 1/10W
C164	1-163-145-00	CERAMIC CHIP 0.0015uF	5% 50V	R114	1-216-101-00	METAL CHIP 150K	5% 1/10W
C165	1-164-004-11	CERAMIC CHIP 0.1uF	10% 25V	R115	1-216-101-00	METAL CHIP 150K	5% 1/10W
C166	1-163-137-00	CERAMIC CHIP 680PF	5% 50V				
C167	1-163-121-00	CERAMIC CHIP 150PF	5% 50V				
C168	1-163-137-00	CERAMIC CHIP 680PF	5% 50V				
C169	1-163-121-00	CERAMIC CHIP 150PF	5% 50V				
C170	1-163-099-00	CERAMIC CHIP 18PF	5% 50V				

BD **LOADING** **MAIN**

Ref. No.	Part No.	Description	Remark
R116	1-216-061-00	METAL CHIP 3.3K 5%	1/10W
R117	1-216-069-00	METAL CHIP 6.8K 5%	1/10W
R118	1-216-063-91	METAL GLAZE 3.9K 5%	1/10W
R119	1-216-085-00	METAL CHIP 33K 5%	1/10W
R120	1-216-089-91	METAL GLAZE 47K 5%	1/10W
R121	1-216-114-00	METAL GLAZE 510K 5%	1/10W
R122	1-216-097-91	METAL GLAZE 100K 5%	1/10W
R123	1-216-099-00	METAL CHIP 120K 5%	1/10W
R124	1-216-091-00	METAL CHIP 56K 5%	1/10W
R125	1-216-069-00	METAL CHIP 6.8K 5%	1/10W
R126	1-216-063-91	METAL GLAZE 3.9K 5%	1/10W
R127	1-216-089-91	METAL GLAZE 47K 5%	1/10W
R128	1-216-098-00	METAL CHIP 110K 5%	1/10W
R129	1-216-049-91	METAL GLAZE 1K 5%	1/10W
R130	1-216-079-00	METAL CHIP 18K 5%	1/10W
R131	1-216-079-00	METAL CHIP 18K 5%	1/10W
R132	1-216-061-00	METAL CHIP 3.3K 5%	1/10W
R133	1-216-061-00	METAL CHIP 3.3K 5%	1/10W
R134	1-216-065-00	METAL CHIP 4.7K 5%	1/10W
R135	1-216-065-00	METAL CHIP 4.7K 5%	1/10W
R136	1-216-073-00	METAL CHIP 10K 5%	1/10W
R137	1-216-065-00	METAL CHIP 4.7K 5%	1/10W
R138	1-216-025-91	METAL GLAZE 100 5%	1/10W
R156	1-216-081-00	METAL CHIP 22K 5%	1/10W
R157	1-216-069-00	METAL CHIP 6.8K 5%	1/10W
R158	1-216-001-00	METAL CHIP 10 5%	1/10W
R159	1-216-121-91	METAL GLAZE 1M 5%	1/10W
R161	1-216-097-91	METAL GLAZE 100K 5%	1/10W
R162	1-216-073-00	METAL CHIP 10K 5%	1/10W
R163	1-216-121-91	METAL GLAZE 1M 5%	1/10W
R164	1-216-061-00	METAL CHIP 3.3K 5%	1/10W
R165	1-216-049-91	METAL GLAZE 1K 5%	1/10W
R166	1-216-073-00	METAL CHIP 10K 5%	1/10W
R167	1-216-081-00	METAL CHIP 22K 5%	1/10W
R168	1-216-073-00	METAL CHIP 10K 5%	1/10W
R169	1-216-079-00	METAL CHIP 18K 5%	1/10W
R170	1-216-081-00	METAL CHIP 22K 5%	1/10W
R171	1-216-073-00	METAL CHIP 10K 5%	1/10W
R172	1-216-079-00	METAL CHIP 18K 5%	1/10W
R173	1-216-049-91	METAL GLAZE 1K 5%	1/10W
R174	1-216-033-00	METAL CHIP 220 5%	1/10W
R175	1-216-025-91	METAL GLAZE 100 5%	1/10W
R176	1-216-049-91	METAL GLAZE 1K 5%	1/10W
R177	1-216-049-91	METAL GLAZE 1K 5%	1/10W
R178	1-216-049-91	METAL GLAZE 1K 5%	1/10W
R179	1-216-025-91	METAL GLAZE 100 5%	1/10W
R180	1-216-025-91	METAL GLAZE 100 5%	1/10W
R181	1-216-025-91	METAL GLAZE 100 5%	1/10W
R188	1-216-037-00	METAL CHIP 330 5%	1/10W
R189	1-216-025-91	METAL GLAZE 100 5%	1/10W
R190	1-216-097-91	METAL GLAZE 100K 5%	1/10W
R191	1-216-105-91	METAL GLAZE 220K 5%	1/10W
		< SWITCH >	
S101	1-572-085-11	SWITCH, LEAF (LIMIT)	
		< VIBRATOR >	
X101	1-767-408-21	VIBRATOR, CRYSTAL (16.9344MHz)	

Ref. No.	Part No.	Description	Remark
*	1-645-721-11	LOADING BOARD *****	
		< CONNECTOR >	
* CN151	1-568-943-11	PIN, CONNECTOR 5P	
		< MOTOR >	
M151	A-4660-692-A	MOTOR (L) ASSY (LOADING)	
		< SWITCH >	
S151	1-572-086-11	SWITCH, LEAF (LOAD OUT)	
S152	1-572-086-11	SWITCH, LEAF (LOAD IN)	

*	A-4699-608-A	MAIN BOARD, COMPLETE (EXCEPT Singapore)	
*	A-4699-609-A	MAIN BOARD, COMPLETE (Singapore) *****	
		< CAPACITOR >	
C301	1-102-978-00	CERAMIC 220PF 5% 50V	
C302	1-130-479-00	MYLAR 0.0047uF 5% 50V	
C303	1-126-967-11	ELECT 47uF 20% 16V	
C304	1-102-978-00	CERAMIC 220PF 5% 50V	
C305	1-130-472-00	MYLAR 0.0012uF 5% 50V	
C306	1-101-006-00	CERAMIC 0.047uF 50V	
C307	1-102-114-00	CERAMIC 470PF 10% 50V	
C351	1-102-978-00	CERAMIC 220PF 5% 50V	
C352	1-130-479-00	MYLAR 0.0047uF 5% 50V	
C353	1-126-967-11	ELECT 47uF 20% 16V	
C354	1-102-978-00	CERAMIC 220PF 5% 50V	
C355	1-130-472-00	MYLAR 0.0012uF 5% 50V	
C356	1-101-006-00	CERAMIC 0.047uF 50V	
C357	1-102-114-00	CERAMIC 470PF 10% 50V	
C401	1-101-006-00	CERAMIC 0.047uF 50V	
C402	1-102-129-00	CERAMIC 10000PF 10% 50V	
C403	1-126-964-11	ELECT 10uF 20% 50V	
C702	1-126-964-11	ELECT 10uF 20% 50V	
C703	1-102-074-00	CERAMIC 0.001uF 10% 50V	
C704	1-104-666-11	ELECT 220uF 20% 25V	
C705	1-126-964-11	ELECT 10uF 20% 50V	
C706	1-126-933-11	ELECT 100uF 20% 16V	
C707	1-126-960-11	ELECT 1uF 20% 50V	
C708	1-126-964-11	ELECT 10uF 20% 50V	
C709	1-126-964-11	ELECT 10uF 20% 50V	
C710	1-126-964-11	ELECT 10uF 20% 50V	
C711	1-126-960-11	ELECT 1uF 20% 50V	
C713	1-164-159-21	CERAMIC 0.1uF 50V	
C714	1-164-159-21	CERAMIC 0.1uF 50V	
C715	1-126-923-11	ELECT 220uF 20% 10V	
C716	1-162-290-31	CERAMIC 470PF 10% 50V	
C717	1-162-290-31	CERAMIC 470PF 10% 50V	
C718	1-164-159-21	CERAMIC 0.1uF 50V	
C719	1-164-159-21	CERAMIC 0.1uF 50V	
C720	1-164-159-21	CERAMIC 0.1uF 50V	
C901	1-126-939-11	ELECT 10000uF 20% 16V	
C902	1-126-768-11	ELECT 2200uF 20% 16V	
C903	1-128-576-11	ELECT 100uF 20% 63V	
C904	1-101-006-00	CERAMIC 0.047uF 50V	
C905	1-101-006-00	CERAMIC 0.047uF 50V	

Ref. No.	Part No.	Description	Remark	Ref. No.	Part No.	Description	Remark
C906	1-101-006-00	CERAMIC 0.047uF	50V	R306	1-249-413-11	CARBON 470 5%	1/4W
C907	1-101-006-00	CERAMIC 0.047uF	50V	R307	1-249-432-11	CARBON 18K 5%	1/4W
C908	1-101-006-00	CERAMIC 0.047uF	50V	R308	1-247-891-00	CARBON 330K 5%	1/4W
		< CONNECTOR >		R309	1-249-421-11	CARBON 2.2K 5%	1/4W
CNS401	1-568-802-11	SOCKET, CONNECTOR 19P		R310	1-247-807-31	CARBON 100 5%	1/4W
CNS402	1-568-838-11	SOCKET, CONNECTOR 21P		R311	1-249-429-11	CARBON 10K 5%	1/4W
		< DIODE >		R312	1-249-429-11	CARBON 10K 5%	1/4W
D401	8-719-987-63	DIODE 1N4148M		R313	1-249-413-11	CARBON 470 5%	1/4W
D402	8-719-109-97	DIODE RD6.8ES-B2		R314	1-249-421-11	CARBON 2.2K 5%	1/4W
D403	8-719-010-34	DIODE UZ-4.7BSC		R351	1-247-848-11	CARBON 5.1K 5%	1/4W
D404	8-719-982-22	DIODE MTZJ-30D		R352	1-249-429-11	CARBON 10K 5%	1/4W
D701	8-719-987-63	DIODE 1N4148M		R353	1-249-432-11	CARBON 18K 5%	1/4W
D702	8-719-987-63	DIODE 1N4148M		R354	1-249-420-11	CARBON 1.8K 5%	1/4W
D703	8-719-987-63	DIODE 1N4148M		R355	1-249-420-11	CARBON 1.8K 5%	1/4W
D704	8-719-987-63	DIODE 1N4148M		R356	1-249-413-11	CARBON 470 5%	1/4W
D705	8-719-987-63	DIODE 1N4148M		R357	1-249-432-11	CARBON 18K 5%	1/4W
D706	8-719-987-63	DIODE 1N4148M		R358	1-247-891-00	CARBON 330K 5%	1/4W
D901	8-719-200-82	DIODE 11ES2		R359	1-249-421-11	CARBON 2.2K 5%	1/4W
D902	8-719-200-82	DIODE 11ES2		R360	1-249-807-31	CARBON 100 5%	1/4W
D903	8-719-200-82	DIODE 11ES2		R361	1-249-429-11	CARBON 10K 5%	1/4W
D904	8-719-200-82	DIODE 11ES2		R362	1-249-429-11	CARBON 10K 5%	1/4W
D905	8-719-200-82	DIODE 11ES2		R363	1-249-413-11	CARBON 470 5%	1/4W
		< TERMINAL BOARD >		R364	1-249-421-11	CARBON 2.2K 5%	1/4W
ET1	1-537-771-21	TERMINAL BOARD, GROUND		R401	1-249-432-11	CARBON 18K 5%	1/4W
		< IC >		R402	1-249-441-11	CARBON 100K 5%	1/4W
IC301	8-759-145-58	IC uPC4558C		R403	1-249-425-11	CARBON 4.7K 5%	1/4W
IC302	8-759-145-58	IC uPC4558C		R404	1-249-441-11	CARBON 100K 5%	1/4W
IC401	8-759-822-09	IC LB1641		R405	1-249-432-11	CARBON 18K 5%	1/4W
IC701	8-759-821-93	IC LA5601		R406	1-249-427-11	CARBON 6.8K 5%	1/4W
		< JACK >		R407	1-249-432-11	CARBON 18K 5%	1/4W
J401	1-770-719-11	JACK, PIN 2P (LINE OUT)		R408	1-249-427-11	CARBON 6.8K 5%	1/4W
		< COIL >		R701	1-249-419-11	CARBON 1.5K 5%	1/4W
L701	1-414-223-11	INDUCTOR 470uH		R702	1-249-441-11	CARBON 100K 5%	1/4W
L703	1-410-322-11	INDUCTOR 3.3uH		R704	1-247-807-31	CARBON 100 5%	1/4W
		< TRANSISTOR >		R705	1-249-417-11	CARBON 1K 5%	1/4W
Q301	8-729-922-37	TRANSISTOR 2SD2144S		R706	1-247-807-31	CARBON 100 5%	1/4W
Q302	8-729-922-37	TRANSISTOR 2SD2144S		R707	1-247-807-31	CARBON 100 5%	1/4W
Q351	8-729-922-37	TRANSISTOR 2SD2144S		R708	1-247-807-31	CARBON 100 5%	1/4W
Q352	8-729-922-37	TRANSISTOR 2SD2144S		R709	1-247-807-31	CARBON 100 5%	1/4W
Q401	8-729-019-65	TRANSISTOR 2SB1041T103				< SWITCH >	
Q402	8-729-119-76	TRANSISTOR 2SA1175-HFE		△S901	1-572-675-11	SWITCH, POWER VOLTAGE CHANGE (VOLTAGE SELECTOR) (Singapore)	
Q701	8-729-029-56	TRANSISTOR DTA144ESA				< TRANSFORMER >	
		< RESISTOR >		△T901	1-426-622-11	TRANSFORMER, POWER (Singapore)	
R301	1-247-848-11	CARBON 5.1K 5%	1/4W	△T901	1-423-979-11	TRANSFORMER, POWER (EXCEPT Singapore)	
R302	1-249-429-11	CARBON 10K 5%	1/4W			< TERMINAL >	
R303	1-249-432-11	CARBON 18K 5%	1/4W	* TM901	1-535-771-11	TERMINAL	
R304	1-249-420-11	CARBON 1.8K 5%	1/4W	* TM902	1-535-771-11	TERMINAL	
R305	1-249-420-11	CARBON 1.8K 5%	1/4W	*****			

The components identified by mark △ or dotted line with mark △ are critical for safety.
Replace only with part number specified.

PANEL

Ref. No.	Part No.	Description	Remark
*	A-4699-606-A	PANEL BOARD, COMPLETE (M205)	
*	A-4699-607-A	PANEL BOARD, COMPLETE (M305)	

< CAPACITOR >			
C502	1-161-494-00	CERAMIC 0.022uF	25V
C503	1-161-494-00	CERAMIC 0.022uF	25V
C504	1-164-159-21	CERAMIC 0.1uF	50V
C505	1-161-494-00	CERAMIC 0.022uF	25V
C506	1-126-933-11	ELECT 100uF 20%	10V (M305)
< CONNECTOR >			
* CNS501	1-568-864-11	SOCKET, CONNECTOR 21P	
< INDICATOR TUBE >			
FL501	1-517-297-11	INDICATOR TUBE, FLUORESCENT	
< IC >			
IC501	8-752-875-60	IC CXP82612-028Q	
IC502	8-759-459-84	IC NJL56H400 (M305)	
< TRANSISTOR >			
Q501	8-729-029-67	TRANSISTOR DTC114ESA-TP	
< RESISTOR >			
R501	1-249-427-11	CARBON 6.8K 5%	1/4W
R502	1-249-427-11	CARBON 6.8K 5%	1/4W
R503	1-249-427-11	CARBON 6.8K 5%	1/4W
R504	1-249-415-11	CARBON 680 5%	1/4W
R505	1-249-417-11	CARBON 1K 5%	1/4W
R506	1-249-419-11	CARBON 1.5K 5%	1/4W
R507	1-249-421-11	CARBON 2.2K 5%	1/4W
R508	1-247-843-11	CARBON 3.3K 5%	1/4W
R509	1-249-427-11	CARBON 6.8K 5%	1/4W
R510	1-249-415-11	CARBON 680 5%	1/4W
R511	1-249-417-11	CARBON 1K 5%	1/4W
R512	1-249-419-11	CARBON 1.5K 5%	1/4W
R513	1-249-421-11	CARBON 2.2K 5%	1/4W
R514	1-247-843-11	CARBON 3.3K 5%	1/4W
R515	1-247-807-31	CARBON 100 5%	1/4W (M305)
R516	1-249-441-11	CARBON 100K 5%	1/4W
R520	1-247-807-31	CARBON 100 5%	1/4W (M305)
R521	1-249-429-11	CARBON 10K 5%	1/4W (M205)
< SWITCH >			
S501	1-554-118-00	SWITCH, PUSH (1 KEY) (POWER)	
S502	1-554-303-21	SWITCH, TACTILE (TIME)	
S503	1-554-303-21	SWITCH, TACTILE (REPEAT)	
S504	1-554-303-21	SWITCH, TACTILE (PEAK SEARCH)	
S505	1-554-303-21	SWITCH, TACTILE (PROGRAM)	

Ref. No.	Part No.	Description	Remark
S506	1-554-303-21	SWITCH, TACTILE (SHUFFLE)	
S507	1-554-303-21	SWITCH, TACTILE (CONTINUE)	
S508	1-554-303-21	SWITCH, TACTILE (OPEN/CLOSE)	
S509	1-554-303-21	SWITCH, TACTILE (▷)	
S510	1-554-303-21	SWITCH, TACTILE (■)	
S511	1-554-303-21	SWITCH, TACTILE (■)	
S512	1-554-303-21	SWITCH, TACTILE (◀◀,▶▶)	
S513	1-554-303-21	SWITCH, TACTILE (▶▶,◀◀)	
< VIBRATOR >			
X501	1-567-819-11	VIBRATOR, CERAMIC (4MHz)	

MISCELLANEOUS			

12	1-773-109-11	WIRE (FLAT TYPE) (19 CORE)	
16	1-773-147-11	WIRE (FLAT TYPE) (21 CORE)	
△21	1-751-535-11	CORD, POWER (UK)	
△21	1-777-447-11	CORD, POWER (EXCEPT UK)	
△22	1-569-008-21	ADAPTOR, CONVERSION 2P (Singapore)	
* 53	1-452-879-11	MAGNET	
△401	8-848-367-11	OPTICAL PICK-UP KSS-213B/K-N	
402	1-769-069-11	WIRE (FLAT TYPE) (16 CORE)	
ET1	1-537-771-21	TERMINAL BOARD, GROUND	
FL501	1-517-297-11	INDICATOR TUBE, FLUORESCENT	
M101	X-4917-523-3	MOTOR ASSY (SPINDLE)	
M102	X-4917-504-1	MOTOR ASSY (SLED)	
M151	A-4660-692-A	MOTOR (L) ASSY (LOADING)	

ACCESSORIES & PACKING MATERIALS			

1-467-316-21	REMOTE COMMANDER (RM-D320) (M305)		
1-558-271-11	CORD, CONNECTION (AUDIO 100cm)		
3-859-691-11	MANUAL, INSTRUCTION (ENGLISH,FRENCH, SPANISH,CHINESE)		
3-859-691-21	MANUAL, INSTRUCTION (GERMAN,DUTCH, ITALIAN,PORTUGUESE) (AEP)		
3-859-691-31	MANUAL, INSTRUCTION (SWEDISH,DANISH, FINNISH) (AEP)		
4-962-615-01	COVER,BATTERY (FOR RM-D320) (M305)		

HARDWARE LIST			

#1	7-685-646-79	SCREW +BVTP 3X8 TYPE2 N-S	
#2	7-621-775-10	SCREW +B 2.6X4	
#3	7-621-255-15	SCREW +P 2X3	

The components identified by mark △ or dotted line with mark △ are critical for safety.
Replace only with part number specified.