

CDP-M34/M44

SERVICE MANUAL

*AEP Model
E Model
Australian Model
CDP-M34*

*AEP Model
UK Model
CDP-M44*



Photo : CDP-M44

Model Name Using Similar Mechanism	CDP-195/295/491
CD Mechanism Type	CDM14-5BD8A
Optical Pick-Up Block Type	BU-5BD8A

SPECIFICATIONS

Compact disc player

Frequency response	2 Hz – 20 kHz \pm 0.5 dB
Signal to noise ratio	More than 100 dB
Dynamic range	More than 98 dB
Harmonic distortion	Less than 0.004% (CDP-M34) Less than 0.0035% (CDP-M44)
Channel separation	More than 100 dB

Outputs

LINE OUT (FIXED) (phono jacks)	Output level 2 V (at 50 kilohms) Load impedance over 10 kilohms
LINE OUT (VARIABLE) (phono jacks)	Output level max. 2 V (at 50 kilohms) Load impedance over 50 kilohms
HEADPHONES (stereo phone jack)	Output level max. 10 mW Load impedance 32 ohms

General

Power requirements	Model for Continental Europe 220 – 230 V AC, 50/60 Hz Model for the United Kingdom 240 V AC, 50/60 Hz Model for other countries 110, 120, 220 or 240 V AC, adjustable 50/60 Hz
--------------------	--

Power consumption 12 W

Dimensions (approx., including projections)
355 \times 95 \times 325 mm (w/h/d)
(14 \times 3⁷/₈ \times 12⁷/₈ inches)

Weight (approx.) 3.2 kg (7 lbs 1 oz)

— Continued on page 2 —

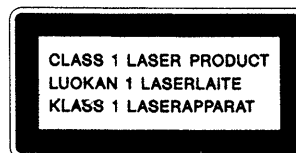

This Compact Disc player is classified as a CLASS 1 LASER product. The CLASS 1 LASER PRODUCT label is located on the rear exterior.

COMPACT DISC PLAYER
SONY[®]

Supplied accessories

Audio cord	1, (2 phono plugs – 2 phono plugs)
Remote commander (only for CDP-M44)	1
R6(size AA) batteries (only for CDP-M44)	2
AC plug adaptor (for some areas)	1

Remote commander RM-D391 (only for CDP-M44)

Remote control system	Infrared control
Power requirements	3 V DC with two R6 (size AA) batteries
Dimensions	Approx. 40×20×175 mm (w/h/d) (1 ³ / ₄ ×1 ³ / ₁₆ ×7 inches)
Weight	Approx. 95 g (4 oz) Including batteries

Design and specifications are subject to change without notice.

PROTECTION OF EYES FROM LASER BEAM DURING SERVICING

This set employs a laser. Therefore, be sure to follow carefully the instructions below when servicing.

CAUTION

Use of controls or adjustments or performance of procedures other than those specified herein may result in hazardous radiation exposure.

NOTES ON HANDLING THE OPTICAL PICK-UP BLOCK OR BASE UNIT

The laser diode in the optical pick-up block may suffer electrostatic breakdown because of the potential difference generated by the charged electrostatic load, etc. on clothing and the human body.



During repair, pay attention to electrostatic breakdown and also use the procedure in the printed matter which is included in the repair parts.

The flexible board is easily damaged and should be handled with care.

- Laser Diode Properties
 - Material: GaAlAs
 - Wavelength: 780nm
 - Emission Duration: continuous
 - Laser Output: max.44.6μW*

* This output is the value measured at a distance of about 200mm from the objective lens surface on the Optical Pick-up Block.
- During service, do not take the Optical Pick-up Block apart, and do not adjust the APC circuit. If there is a breakdown in the APC circuit (including laser diode), replace the entire Optical Pick-up Block (including APC board).

SAFETY-RELATED COMPONENT WARNING!!

COMPONENTS IDENTIFIED BY MARK  OR DOTTED LINE WITH MARK  ON THE SCHEMATIC DIAGRAMS AND IN THE PARTS LIST ARE CRITICAL TO SAFE OPERATION. REPLACE THESE COMPONENTS WITH SONY PARTS WHOSE PART NUMBERS APPEAR AS SHOWN IN THIS MANUAL OR IN SUPPLEMENTS PUBLISHED BY SONY.

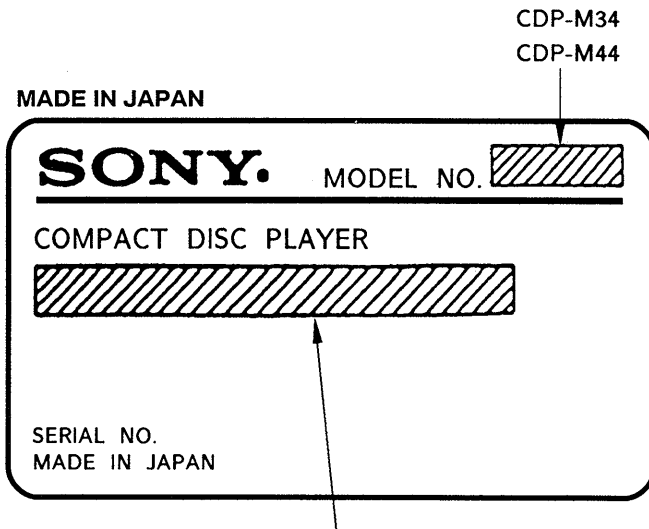
MODEL IDENTIFICATION- *Specification Label* -

AEP Model : AC 220 - 230V ~ 50/60Hz
 Australian Model : AC 240V ~ 50/60Hz
 E, Saudi Arabia Model : AC 110 - 120V, 220 - 240V,
 ~ 50/60Hz 12W

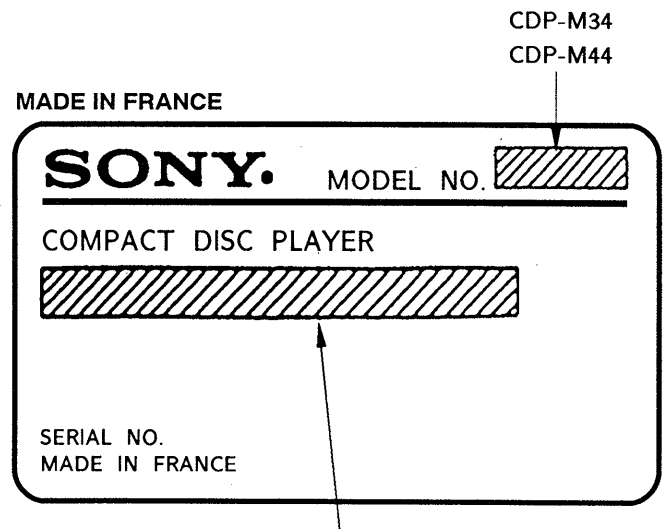

AEP Model : AC 220 - 230V ~ 50/60Hz
 UK Model : AC 240V, ~ 50/60Hz

TABLE OF CONTENTS

<i>Section</i>	<i>Title</i>	<i>Page</i>
Specifications		1
1. GENERAL		
1-1	Location of Controls	4
2. DISASSEMBLY		5
3. ELECTRICAL BLOCK CHECKING		6
4. DIAGRAMS		
4-1	Block Diagram	8
4-2	Circuit Boards Location	10
4-3	Semiconductor Lead Layouts	11
4-4	Printed Wiring Boards (MAIN Board)	12
4-5	Schematic Diagram (MAIN Board)	15
4-6	Printed Wiring Boards (BD Board)	18
4-7	Schematic Diagram (BD Board)	19
4-8	IC Block Diagrams	21
5. EXPLODED VIEWS		23
6. ELECTRICAL PARTS LIST		27

SECTION 1 GENERAL

This section is extracted from instruction manual.

1-1 LOCATION OF CONTROLS

Front Panel

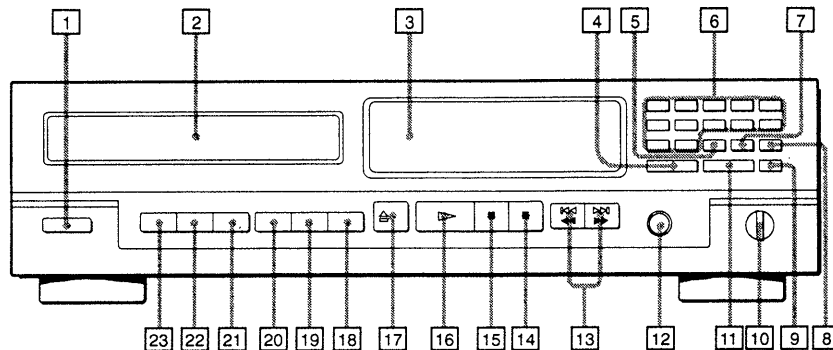

CDP-M44

Refer to the pages indicated in ● for details.

- 1 POWER switch ●
- 2 Disc tray ●
- 3 Remote sensor ●
- 4 EDIT/TIME FADE button ●, ●, ●
- 5 CHECK (program check) button ●
- 6 Numeric buttons ●, ●
- 7 CLEAR (program clear) button ●, ●
- 8 > 12 (over 12) button ●
- 9 P.SEARCH button ●
- 10 LINE OUT/PHONE LEVEL control (for CDP-M44)
PHONE LEVEL (for CDP-M34) ●, ●
- 11 MUSIC SCAN button ●, ●
- 12 HEADPHONES jack

- 13 ◀◀◀◀/▶▶▶▶ (AMS*/RMS**/manual search) buttons ●, ●, ●, ●, ●
- 14 ■ (stop) button ●
- 15 || (pause) button ●
- 16 ▶ (play) button ●
- 17 ▲ (open/close) button ●
- 18 FADER button ●
- 19 REPEAT button ●
- 20 TIME button ●
- 21 PROGRAM button ●
- 22 SHUFFLE button ●, ●
- 23 CONTINUE button ●, ●, ●

* AMS is the abbreviation of Automatic Music Sensor.
** RMS is the abbreviation of Random Music Sensor.

Remote Commander (Only for CDP-M44)

(RM-D391)

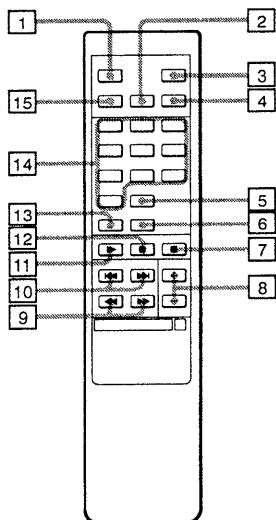

- 1 M.SCAN (music scan) button ●, ●
- 2 SHUFFLE button ●, ●
- 3 FADER button ●
- 4 PROGRAM button ●
- 5 > 10 (over 10) button ●
- 6 REPEAT button ●
- 7 ■ (stop) button ●
- 8 LINE OUT LEVEL +/- buttons ●, ●
- 9 ◀◀▶▶ (manual search) buttons ●, ●
- 10 ◀◀◀◀▶▶▶▶ AMS buttons ●, ●, ●, ●
- 11 ▶ (play) button ●
- 12 || (pause) button ●
- 13 TIME button ●
- 14 Numeric buttons ●, ●
- 15 CONTINUE button ●, ●, ●

SECTION 2 DISASSEMBLY

Note :

Follow the disassembly procedure in the numerical order given.

- ① Turn the cam to the direction of arrow (Counter clock wise) by minus screw driver.
- ② Take off the disc table.
- ③ Remove the yoke bracket.
- ④ Remove the MD (BU-5BD8A) to the direction of arrow.

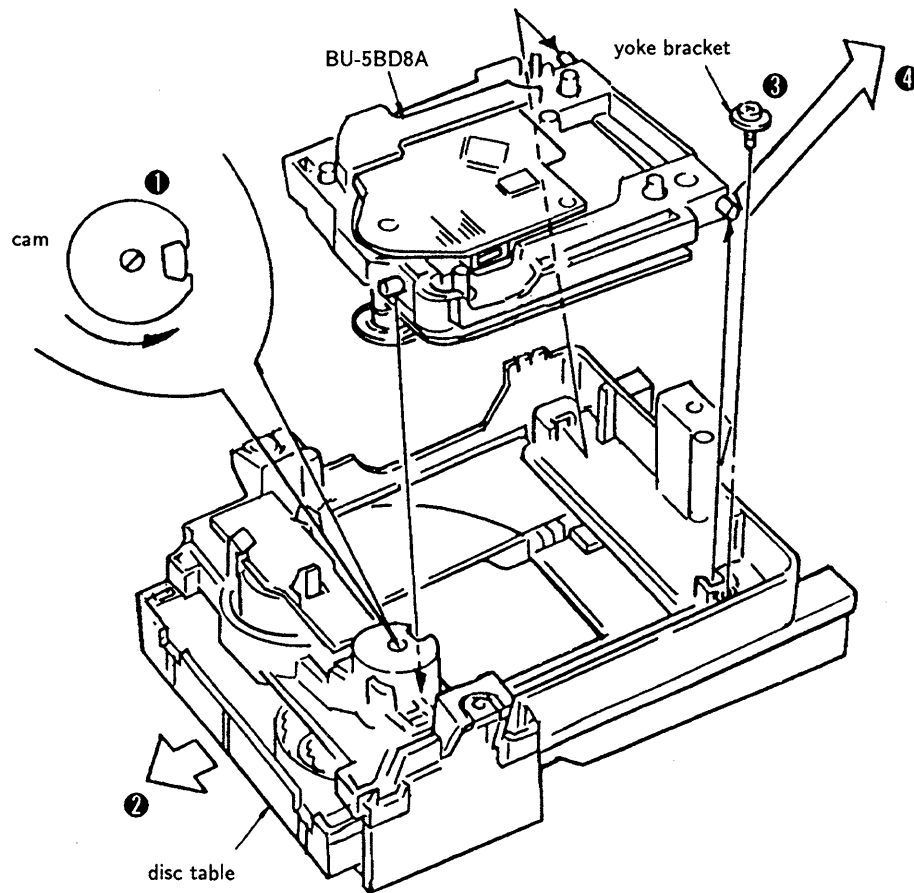

SECTION 3

ELECTRICAL BLOCK CHECKING

Note :

1. CD Block basically constructed to operate with-out adjustment. Therefore, check each item in order given.
2. Use YEDS-18 disc (3-702-101-01) unless otherwise indicated.
3. Use the oscilloscope with more than $10M\Omega$ impedance.
4. Clean an object lens by an applicator with neutral detergent when the signal level is low than specified value with the following checks.

S Curve Check

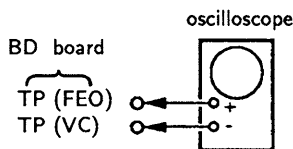

Procedure :

1. Connect oscilloscope to test point TP (FEO) on BD board.
2. Connect between test point TP (FEI) and TP (VC) by lead wire.
3. Turned Power switch on and actuate the focus serch. (actuate the focus serch when disc table is moving in and out.)
4. Check the oscilloscope waveform (S curve) is symmetrical between A and B. And confirm peak to peak level within $3\pm 1V_{p-p}$.

S curve waveform

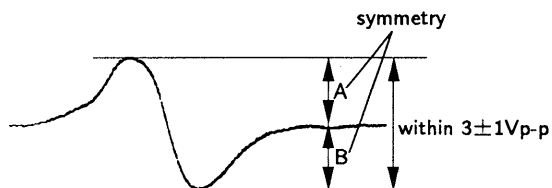

5. After check, remove the lead wire connected in step 2.

Note :

- Try to measure several times to make sure that the ratio of A : B or B : A is more than 10 : 7.
- Take sweep time as long as possible and light up the brightness to obtain best waveform.

RF Level Check

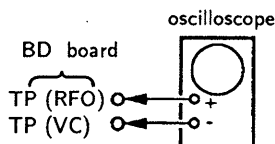

Procedure :

1. Connect oscilloscope to test point TP (RFO) on BD board.
2. Turn Power switch on.
3. Put disc (YEDS-18) in and playback.
4. Confirm that oscilloscope waveform is clear and check RF signal level is correct or not.

Note :

Clear RF signal waveform means that the shape "◇" can be clearly distinguished at the center of the waveform.

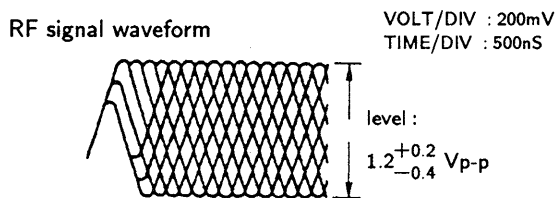

E-F Balance Check

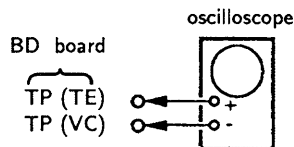

Procedure :

1. Connect test point TP (ADJ) to ground and TP (TEI) to TP (VC) with lead wire.
2. Connect oscilloscope to test point TP (TE) on BD board.
3. Turn Power switch on.
4. Put disc (YEDS-18) in and playback.
5. Confirm that the oscilloscope waveform is symmetrical on the top and bottom in relation to 0V, and check this level.

Traverse oscilloscope

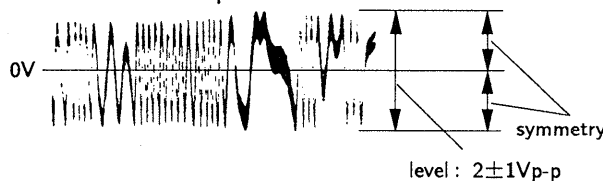

6. Remove the lead wire connected in step 1.

RF PLL Free-run Frequency Check

Procedure :

1. Connect frequency counter to test point (PLCK) with lead wire.

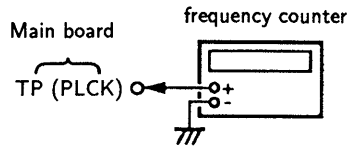

2. Turn Power switch on.
3. Confirm that reading on frequency counter is 4.3218 MHz.

Adjustment Location :

【MAIN BOARD】

- Component side -

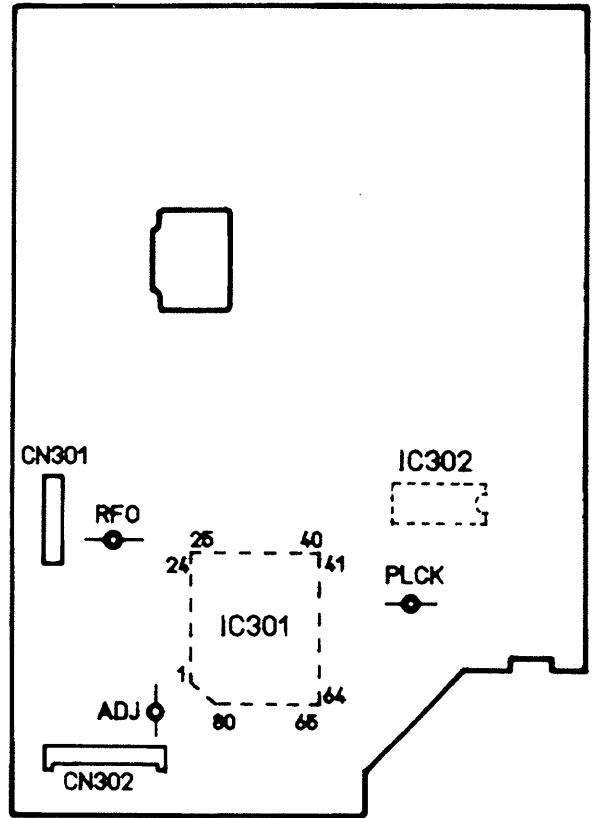

【BD BOARD】

- Solder side -

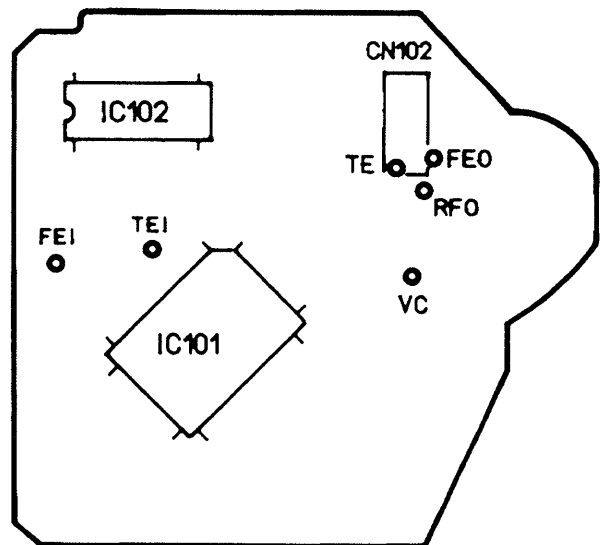

SECTION 4 DIAGRAMS

4-1 BLOCK DIAGRAM

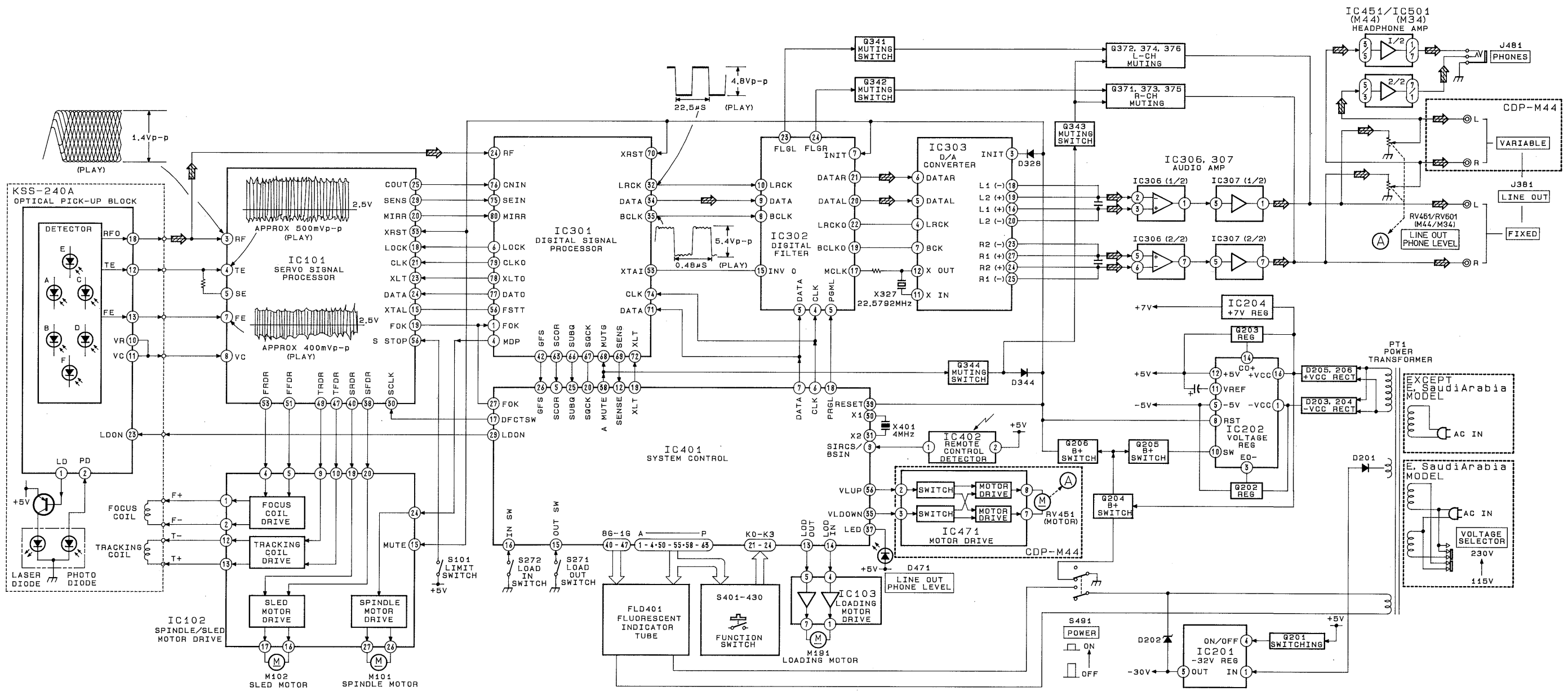

4-2 CIRCUIT BOARDS LOCATION

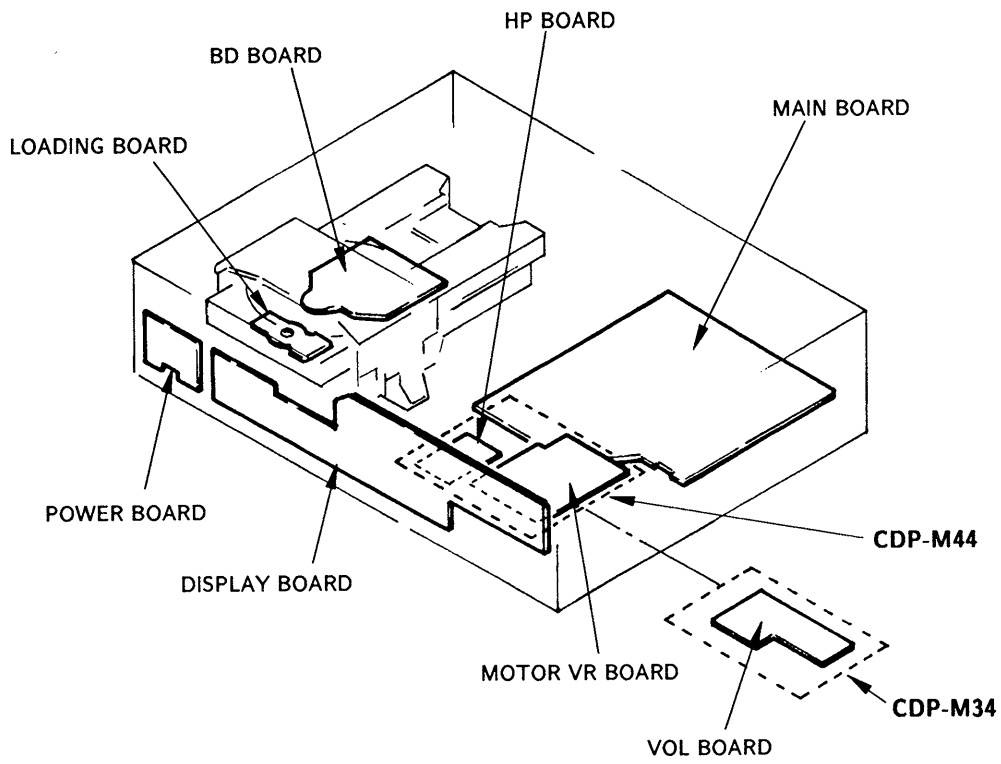

4-3 SEMICONDUCTOR LEAD LAYOUTS

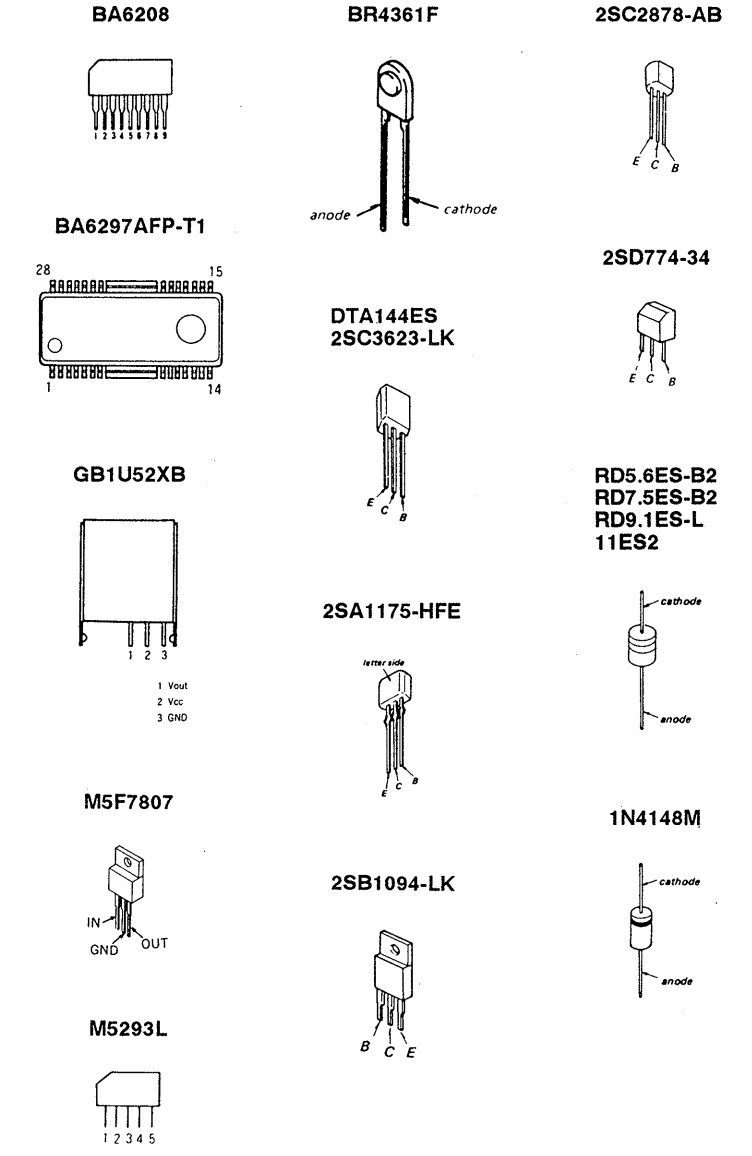

● SEMICONDUCTOR LOCATION

Ref. No.	Location	Ref. No.	Location
D201	E-19	IC303	F-15
D202	F-19	IC306	D-15
D203	E-19	IC307	C-15
D204	E-19	IC401	D-7
D205	E-18	IC402	D-5
D206	E-18	IC451	G-10
D208	E-17	IC471	G-11
D209	E-17	IC501	G-4
D328	F-14		I-4
D344	G-14		
D401	D-12	Q201	F-19
D402	D-12	Q202	F-19
D403	D-11	Q203	F-18
D404	D-10	Q204	G-19
D405	D-10	Q205	G-19
D406	B-5	Q206	G-19
D407	B-5	Q341	E-14
D408	B-5	Q342	E-14
D409	C-7	Q343	E-14
D412	D-6	Q344	G-14
D471	I-10	Q371	B-15
		Q372	C-17
		Q373	B-15
		Q374	C-17
IC201	F-19		
IC202	G-18		
IC204	F-19	Q375	B-15
IC301	H-17	Q376	B-17
IC302	G-15		

Note:
 ○ : parts extracted from the component side.
 ■ : parts mounted on the conductor side.
 ● : Pattern on the side which is seen.
 ◐ : Pattern of the rear side.

4-4 PRINTED WIRING BOARDS (MAIN BOARD)

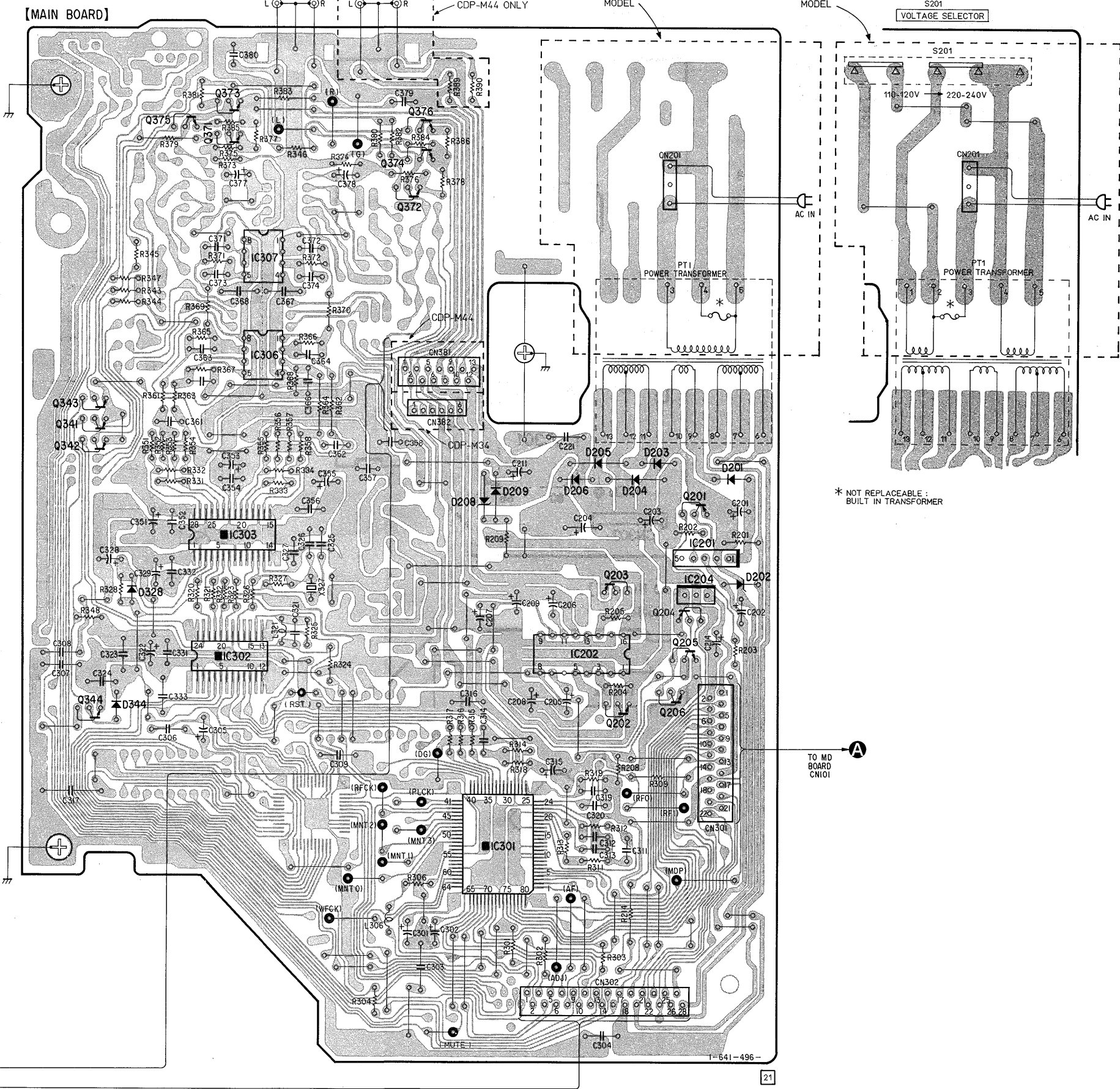
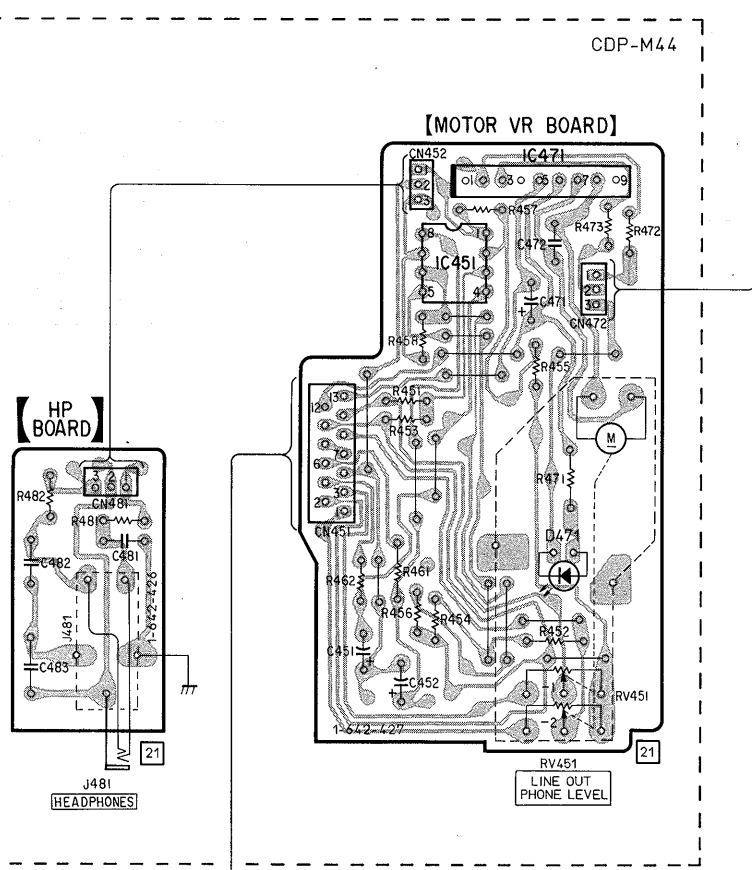
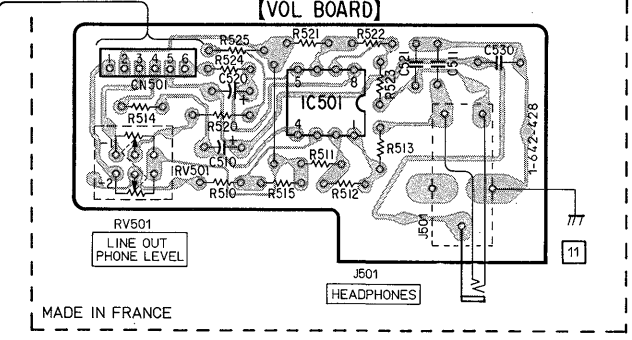
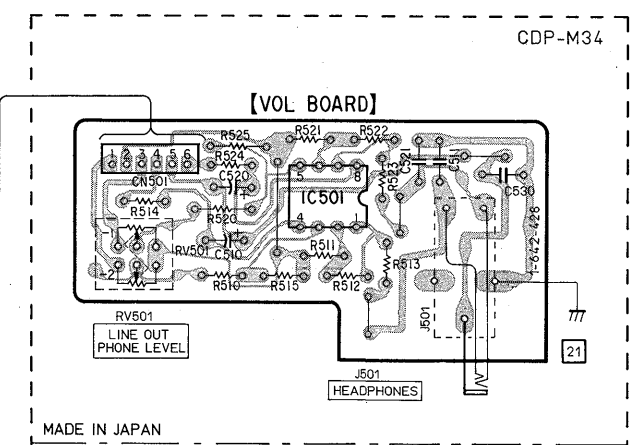
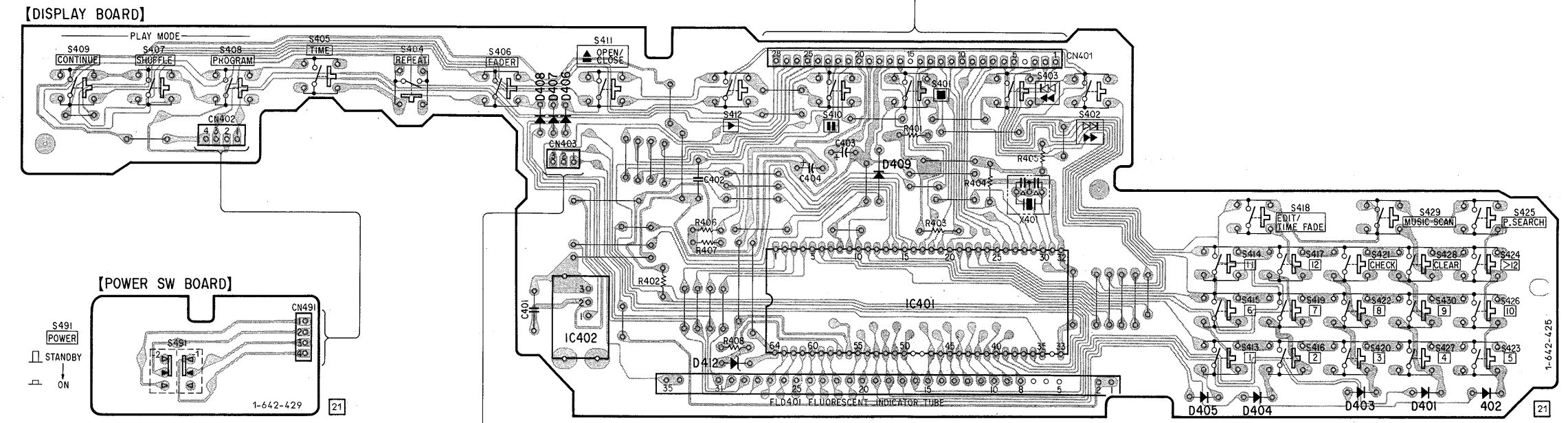
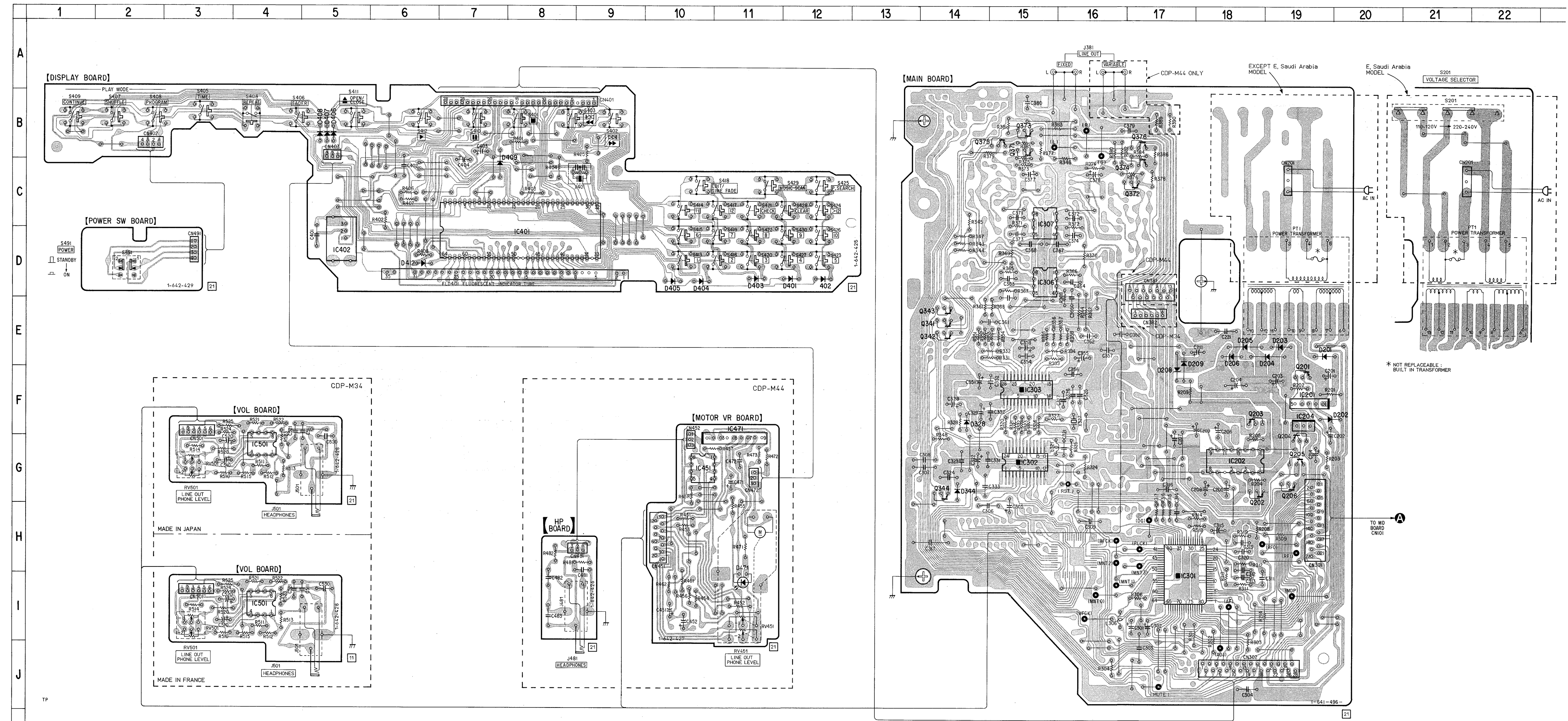

4-5 SCHEMATIC DIAGRAM (MAIN BOARD)

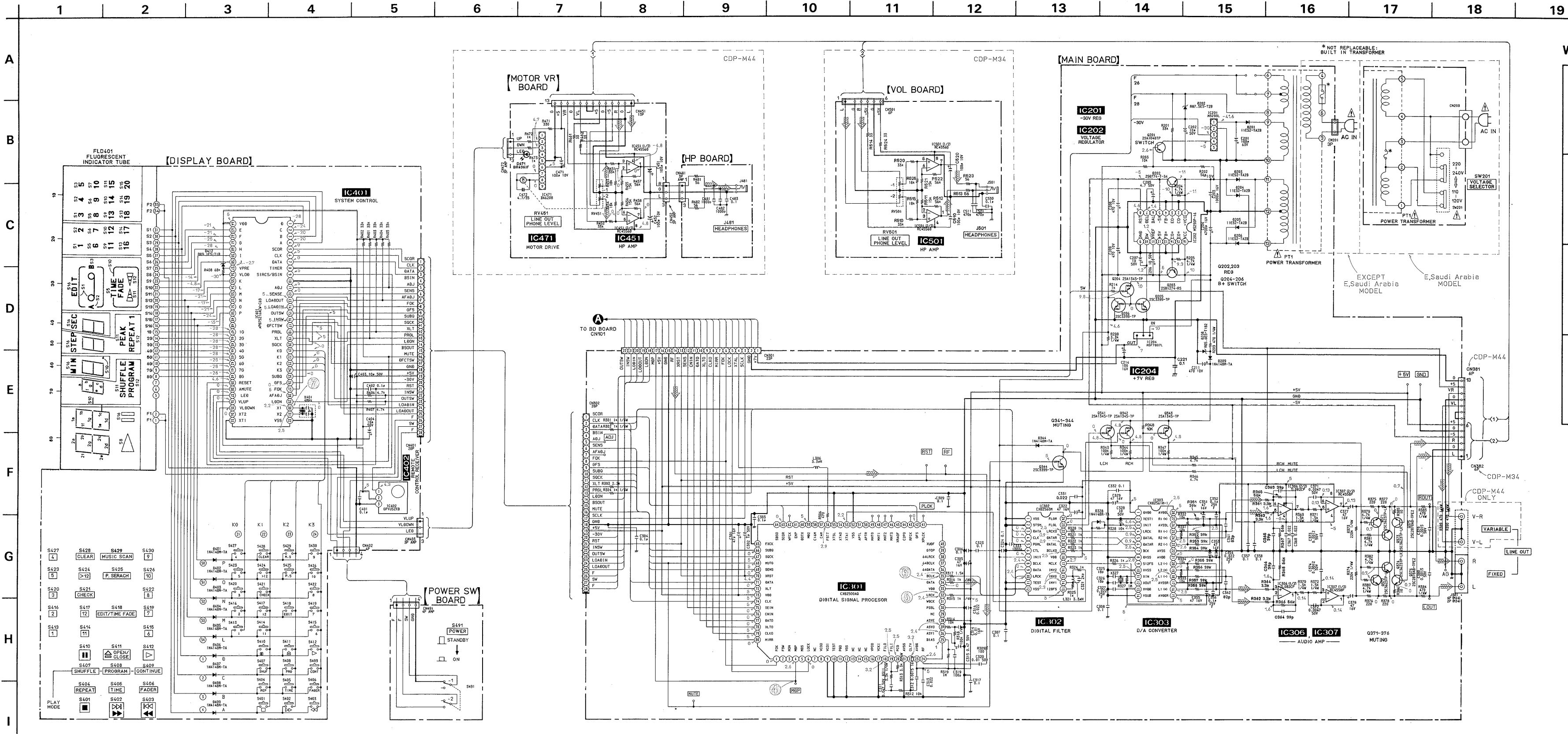

WAVEFORMS

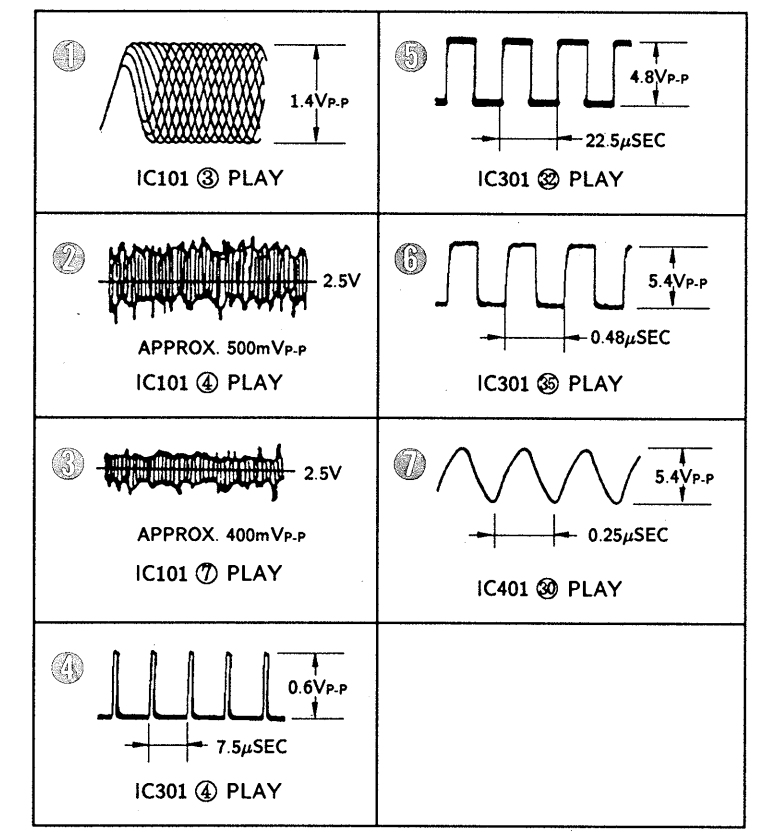

Note:

- All capacitors are in μF unless otherwise noted. pF : $\mu \mu F$ 50WV or less are not indicated except for electrolytics and tantalums.
- All resistors are in Ω and $\frac{1}{4}W$ or less unless otherwise specified.
- Δ : internal component.

Note: The components identified by mark Δ or dotted line with mark Δ are critical for safety. Replace only with part number specified.

- \square : B+ Line
- \square : B- Line
- Voltage and waveforms are dc with respect to ground under no-signal (STOP) conditions.
- Voltagess are taken with a VOM (input impedance 10M Ω). Voltage variations may be noted due to normal production tolerances.
- Waveforms are taken with an oscilloscope. Voltage variations may be noted due to normal production tolerances.
- Circled numbers refer to waveforms.
- Signal path.
- \Rightarrow : CD

4-6 PRINTED WIRING BOARDS (BD BOARD)

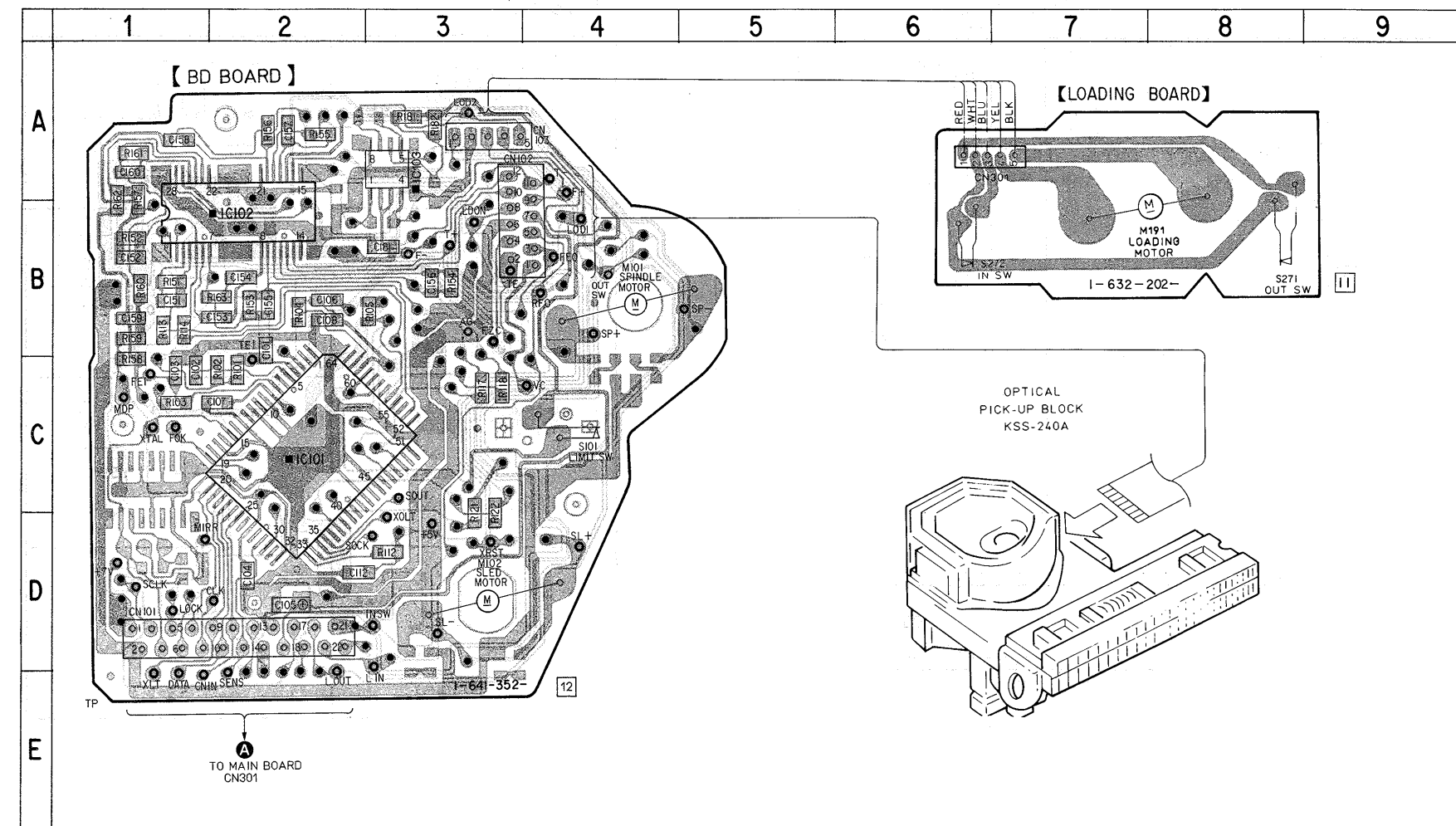

Note:

- : parts extracted from the component side.
- : parts mounted on the conductor side.
- ⊙ : Pattern on the side which is seen.
- ⊙ : Pattern of the rear side.

4-7 SCHEMATIC DIAGRAM (BD BOARD)

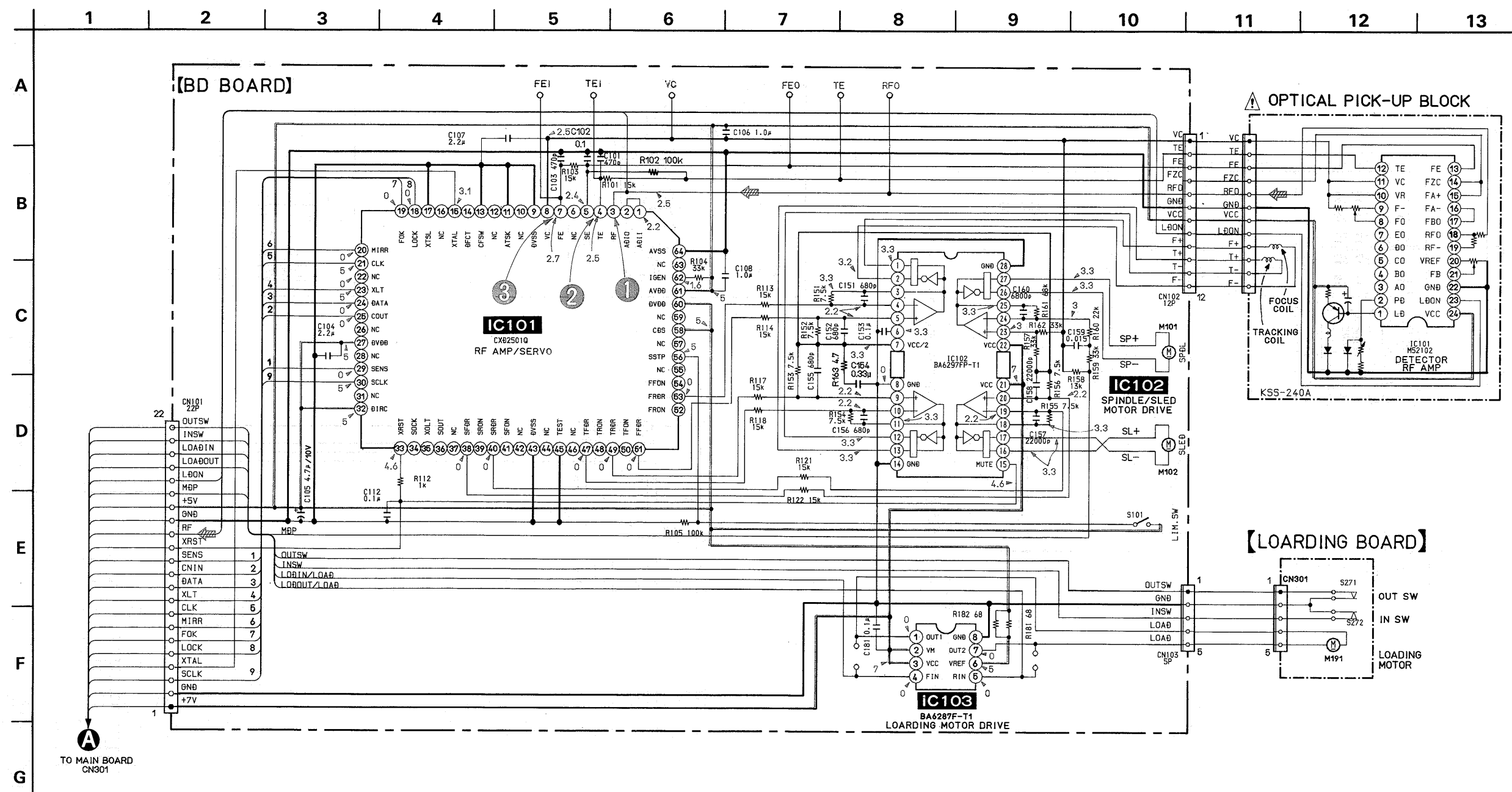

NOTE:

- All capacitors are in μF unless otherwise noted. pF : $\mu\mu F$ 50WV or less are not indicated except for electrolytics and tantalums.
- All resistors are in Ω and $\frac{1}{4}W$ or less unless otherwise specified.
- Δ : internal component.
- : B+ Line
- : B- Line
- Voltage and waveforms are dc with respect to ground under no-signal (STOP) conditions.
- Voltagages are taken with a VOM (Input impedance 10M Ω). Voltage variations may be noted due to normal production tolerances.
- Waveforms are taken with an oscilloscope. Voltage variations may be noted due to normal production tolerances.
- Circled numbers refer to waveforms.
- Signal path.
- ⊞ : CD

Note: The components identified by mark Δ or dotted line with mark Δ are critical for safety. Replace only with part number specified.

4-8 IC BLOCK DIAGRAM

IC101 CXD2501Q

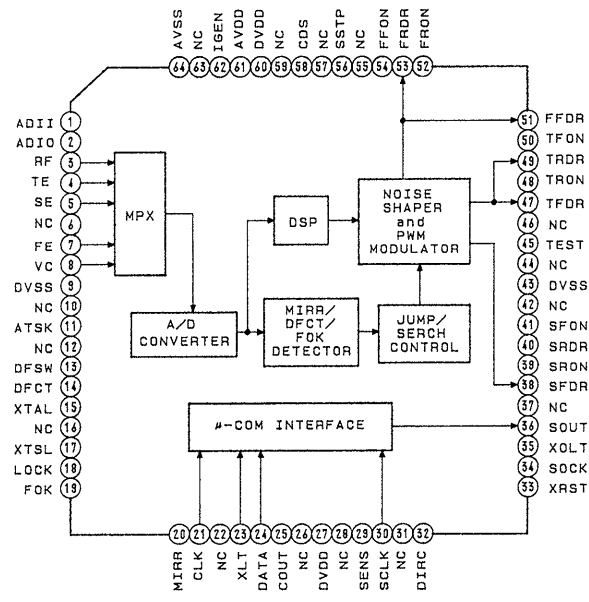

IC202 M5290P-16

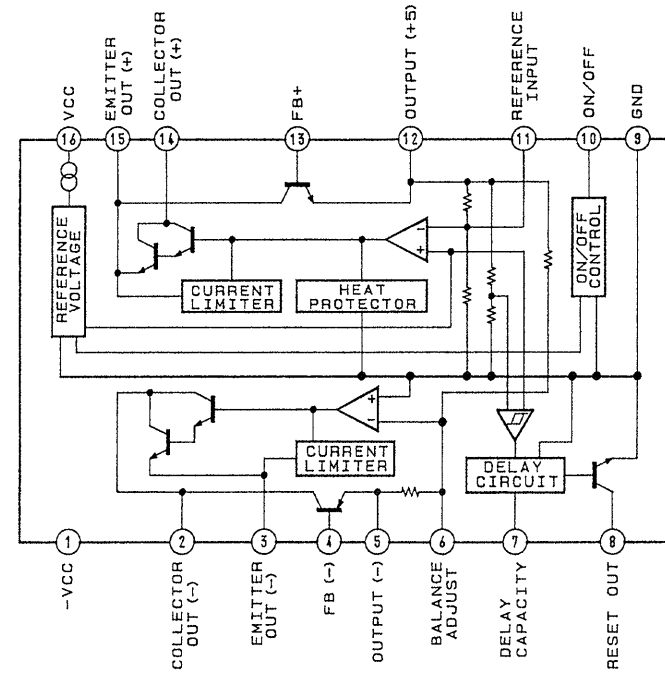

IC302 CXD2560M

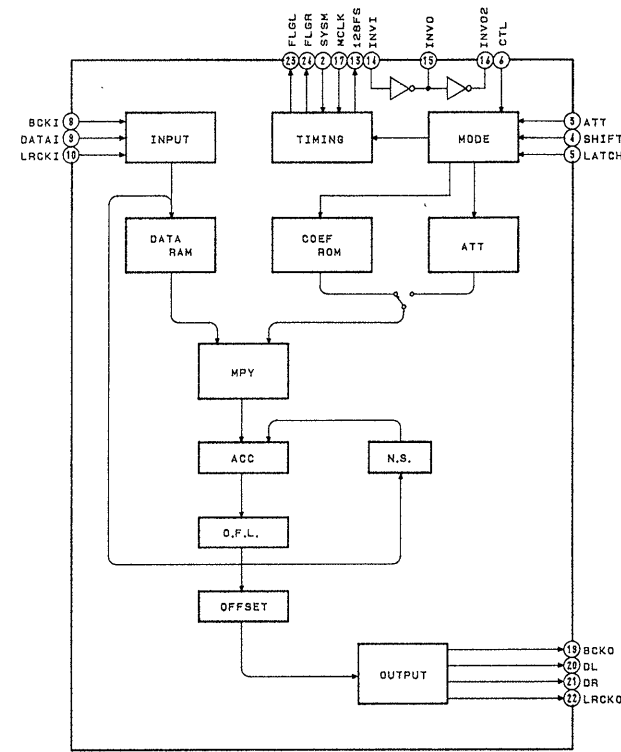

IC471 BA6208

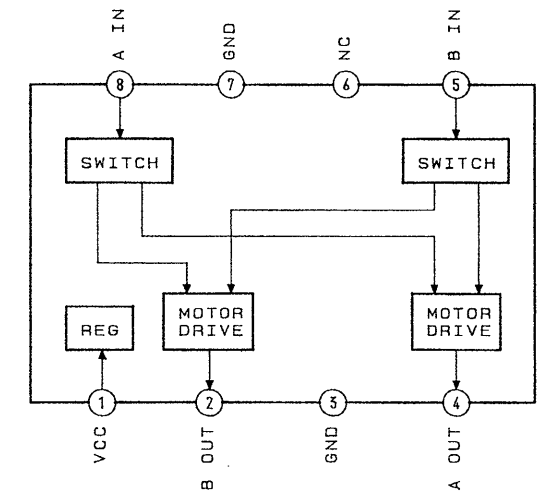

IC103 BA6287F-T1

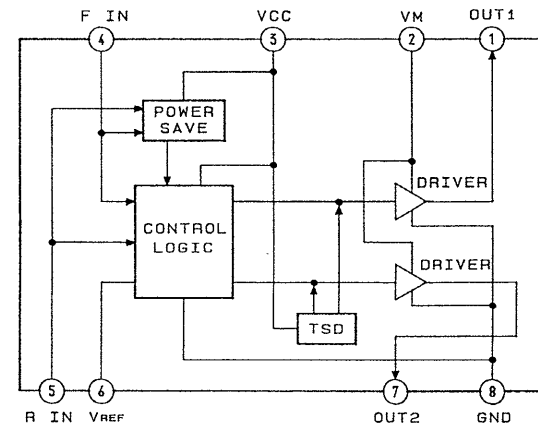

IC301 CXD2500AQ

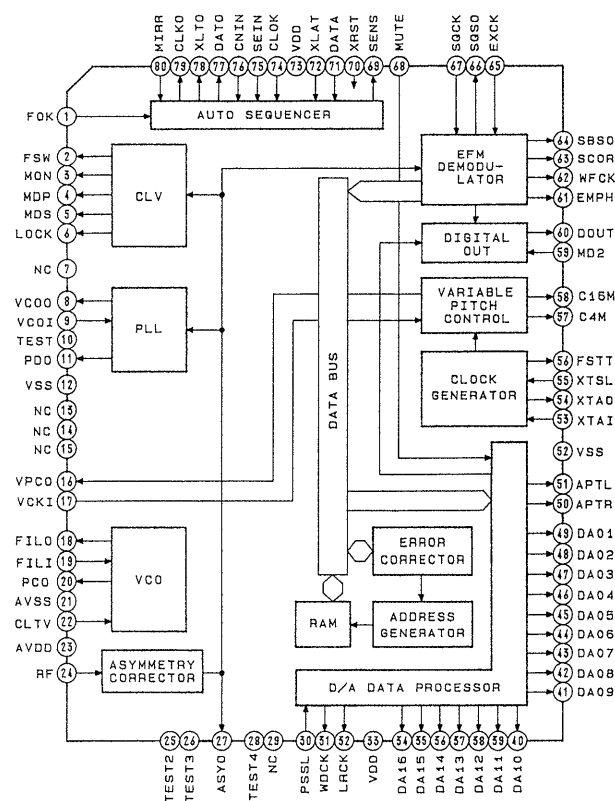

IC303 CXD2561AM

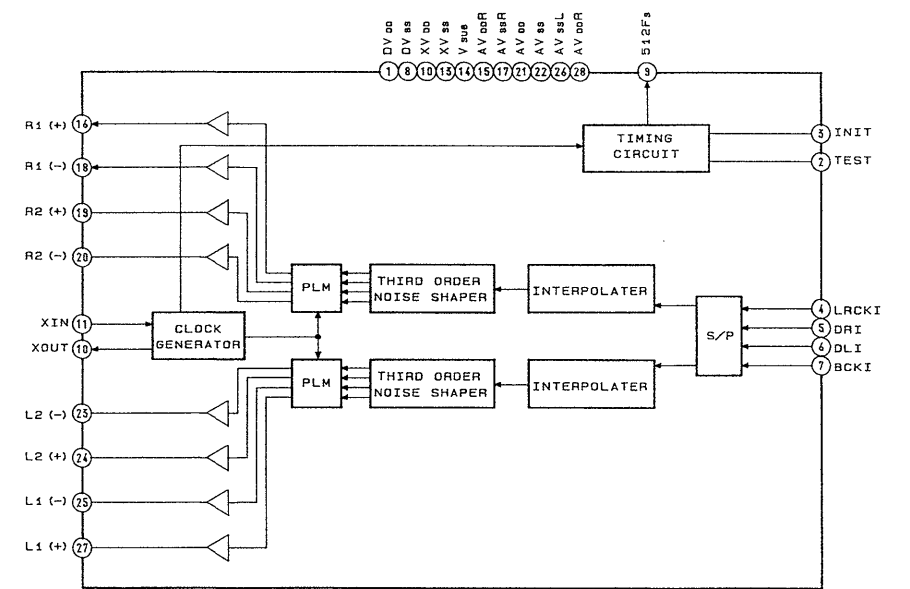

IC201 M5293L

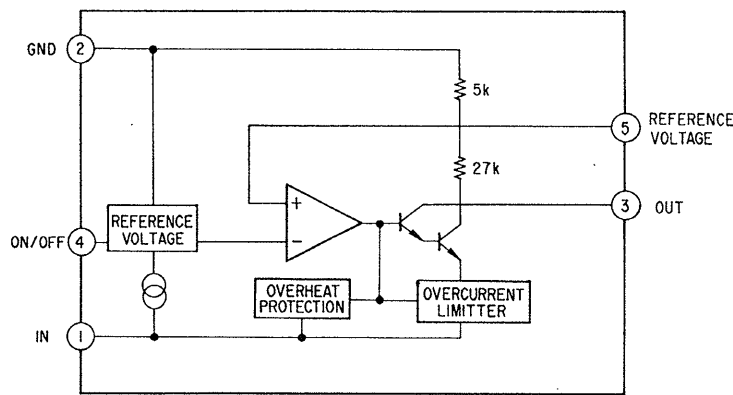

SECTION 5 EXPLODED VIEWS

NOTE:

- -XX, -X mean standardized parts, so they may have some differences from the original one.
- The construction parts of an assembled part are indicated with a collation number in the remark column.
- Color indication of Appearance Parts
Example:
KNOB, BALANCE (WHITE)....(RED)

↑ Parts color ↑ Cabinet's color

- Items marked "*" are not stocked since they are seldom required for routine service. Some delay should be anticipated when ordering these items.
- The mechanical parts with no reference number in the exploded views are not supplied.
- Hardware (# mark) list is given in the last of this parts list.

The components identified by mark or dotted line with mark are critical for safety. Replace only with part number specified.

When indicating parts by reference number, please include the board.

(1) CABINET SECTION

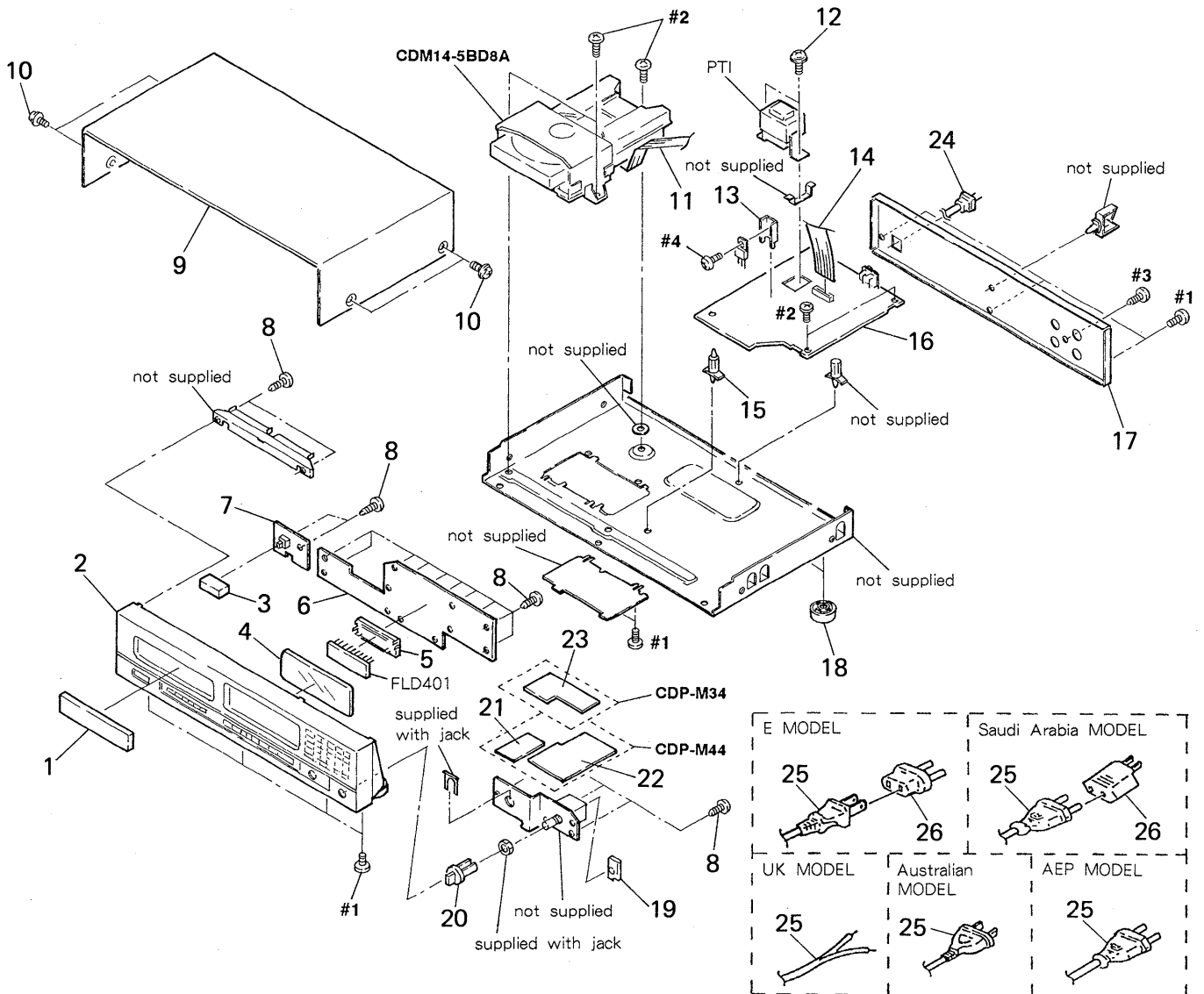

E MODEL	Saudi Arabia MODEL
UK MODEL	Australian MODEL
AEP MODEL	

Ref.No.	Part No.	Description	Remark
1	4-949-178-01	PANEL, LOADING(M44)	
1	4-949-178-11	PANEL, LOADING(M34)	
2	X-4942-158-2	PANEL ASSY, FRONT(M44:AEP,UK) (MADE IN FRANCE)	
2	X-4942-159-1	PANEL ASSY, FRONT(M44:AEP) (MADE IN JAPAN)	
2	X-4942-160-1	PANEL ASSY, FRONT(M34:AEP, E, Saudi Arabia) (MADE IN JAPAN)	
2	X-4942-223-2	PANEL ASSY, FRONT(M34:AEP) (MADE IN FRANCE)	
3	4-927-341-01	BUTTON (POWER)	
4	4-942-983-01	PLATE (TYPE-B), INDICATION(M44)	
4	4-942-983-11	PLATE (TYPE-B), INDICATION(M34)	
* 5	4-923-103-01	HOLDER, FL TUBE	
* 6	A-4649-122-A	DISP BOARD, COMPLETE (M34:AEP, E, Saudi Arabia)	
* 6	A-4649-127-A	DISP BOARD, COMPLETE(M44)	
* 7	1-642-429-11	POWER SW BOARD	
8	4-928-635-01	SCREW, +BV (2.6X8) TAPPING (M34:AEP/M44:AEP,UK)(MADE IN FRANCE)	
8	4-951-620-01	SCREW (2.6X8), +BVTP(M34:AEP, E, Saudi Arabia/M44:AEP)(MADE IN JAPAN)	
9	4-919-376-31	CASE	
10	3-363-099-01	SCREW (CASE +3X8 TP2)(M34:AEP/M44:AEP,UK) (MADE IN FRANCE)	
10	3-704-366-01	SCREW (CASE) (M3X8)(M34:AEP, Saudi Arabia/ M44:AEP)(MADE IN JAPAN)	
11	1-575-160-11	WIRE, FLAT TYPE (22 CORE)	
12	4-886-821-11	SCREW, S TIGHT, +PTTWH 3X6	
13	4-902-345-01	HEAT SINK	
14	1-690-392-11	WIRE, FLAT TYPE (13 CORE)(M44)	
* 15	4-924-098-31	HOLDER, PC BOARD	
* 16	A-4649-124-A	MAIN BOARD, COMPLETE(M34)	
* 16	A-4649-125-A	MAIN BOARD, COMPLETE (M34:E, Saudi Arabia)	
* 16	A-4649-130-A	MAIN BOARD, COMPLETE(M44)	
* 17	4-941-467-31	PANEL (ALSACE), BACK(M44:AEP,UK) (MADE IN FRANCE)	

Ref.No.	Part No.	Description	Remark
* 17	4-941-467-41	PANEL (ALSACE), BACK(M34:AEP) (MADE IN FRANCE)	
* 17	4-949-183-02	PANEL, BACK(M44:AEP)(MADE IN JAPAN)	
* 17	4-949-183-32	PANEL, BACK(M34:AEP)(MADE IN JAPAN)	
* 17	4-949-183-52	PANEL, BACK(M34:E, Saudi Arabia) (MADE IN JAPAN)	
* 17	4-949-183-41	PANEL, BACK(M34:Australian)	
18	4-933-601-01	FOOT	
* 19	4-922-980-01	HOLDER (LED)(M44)	
20	4-922-531-01	KNOB (A TYPE), LOV(M34)	
20	A-4604-727-A	KNOB (HP) ASSY(M44)	
* 21	1-642-426-11	HP BOARD	
* 22	1-642-427-11	MOTOR VR BOARD(M44)	
* 23	1-642-428-11	VOL BOARD	
* 24	3-703-244-00	BUSHING (2104), CORD(M34:ABP, Saudi Arabia/ M44:AEP)(MADE IN JAPAN)	
* 24	3-703-571-11	BUSHING (S) (4516), CORD(M34:E) (MADE IN JAPAN)	
24	4-946-787-01	BUSHING, CORD(M34:AEP/M44:AEP,UK) (MADE IN FRANCE)	
△ 25	1-574-127-31	CORD, POWER(M34/M44:AEP) (MADE IN FRANCE)	
△ 25	1-574-390-31	CORD, POWER(M44:UK)(MADE IN FRANCE)	
△ 25	1-575-651-21	CORD, POWER(M34:AEP, Saudi Arabia/M44:AEP) (MADE IN JAPAN)	
△ 25	1-575-653-21	CORD, POWER(M34:E)(MADE IN JAPAN)	
△ 25	1-574-358-31	CORD, POWER(M34:Australian)	
△ 26	1-569-007-11	ADAPTER, CONVERSION 2P(M34:E)	
△ 26	1-569-008-11	ADAPTER, CONVERSION 2P(M34:Saudi Arabia)	
FLD401	1-519-611-11	INDICATOR TUBE, FLUORESCENT	
△ PT1	1-449-922-11	TRANSFORMER, POWER(M34/M44:AEP)	
△ PT1	1-449-923-11	TRANSFORMER, POWER(M34:E, Saudi Arabia)	

(2) MD SECTION (CDM14-5BD8A)

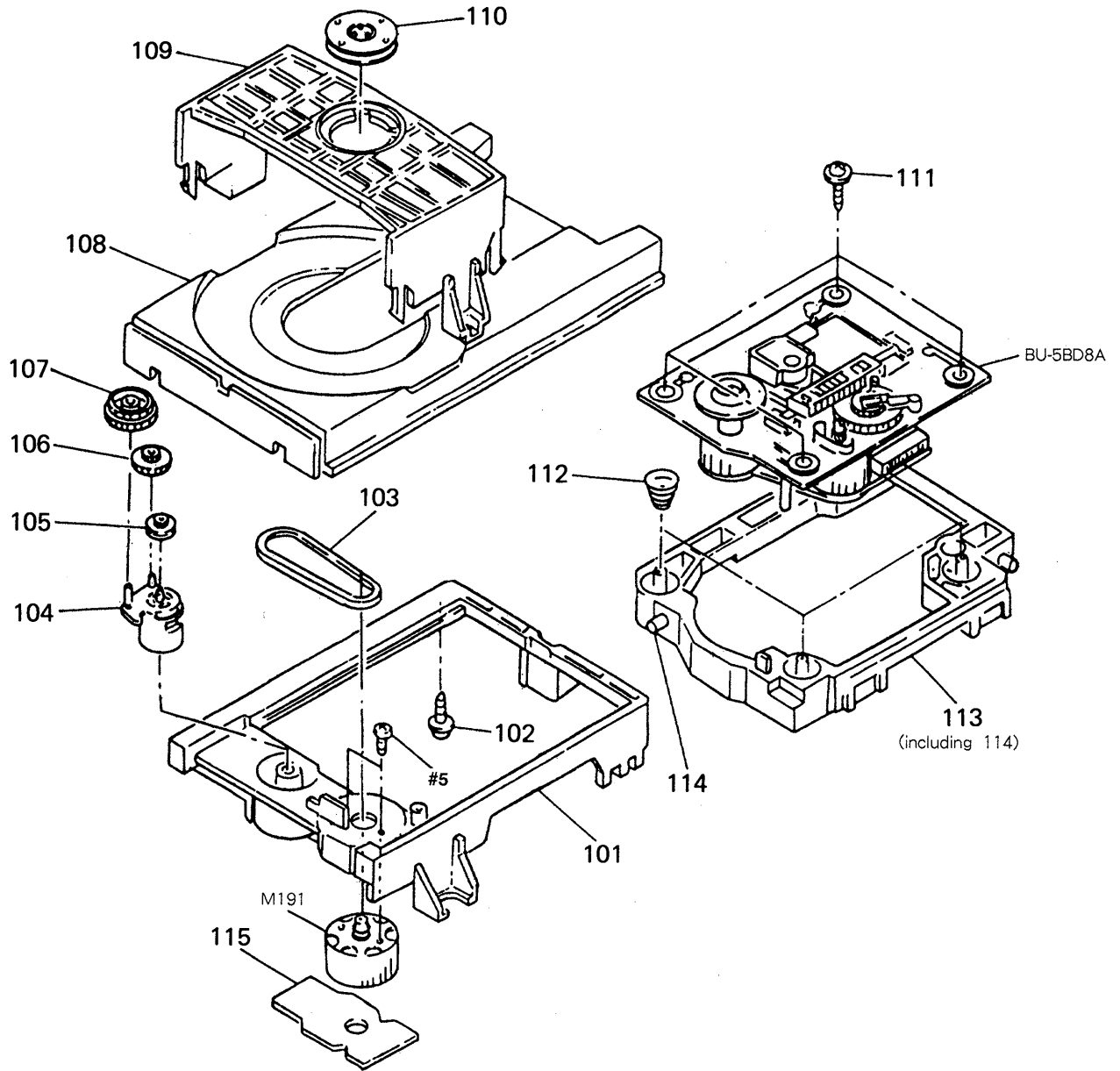

Ref.No.	Part No.	Description	Remark
101	4-933-111-01	CHASSIS (MD)	
* 102	4-917-583-21	BRACKET, YOKE	
103	4-927-649-01	BELT	
104	4-933-109-01	CAM	
105	4-927-651-01	PULLEY (S)	
106	4-927-628-01	GEAR (C)	
107	4-933-107-01	GEAR (PL)	
108	4-933-112-01	TABLE, DISK	
109	4-933-110-01	HOLDER (MG)	

Ref.No.	Part No.	Description	Remark
* 110	1-452-538-11	MAGNET	
111	4-933-134-01	SCREW (+PTPWH M2.6X6)	
112	4-948-503-01	SPRING (BU), COMPRESSION	
113	4-933-129-01	HOLDER (BU)	
114	4-933-108-01	SHAFT (CAM)	
* 115	1-632-202-11	LOADING BOARD	
M191	A-4604-363-A	MOTOR (L) ASSY	

(3) PICK-UP BLOCK (BU-5BD8A)

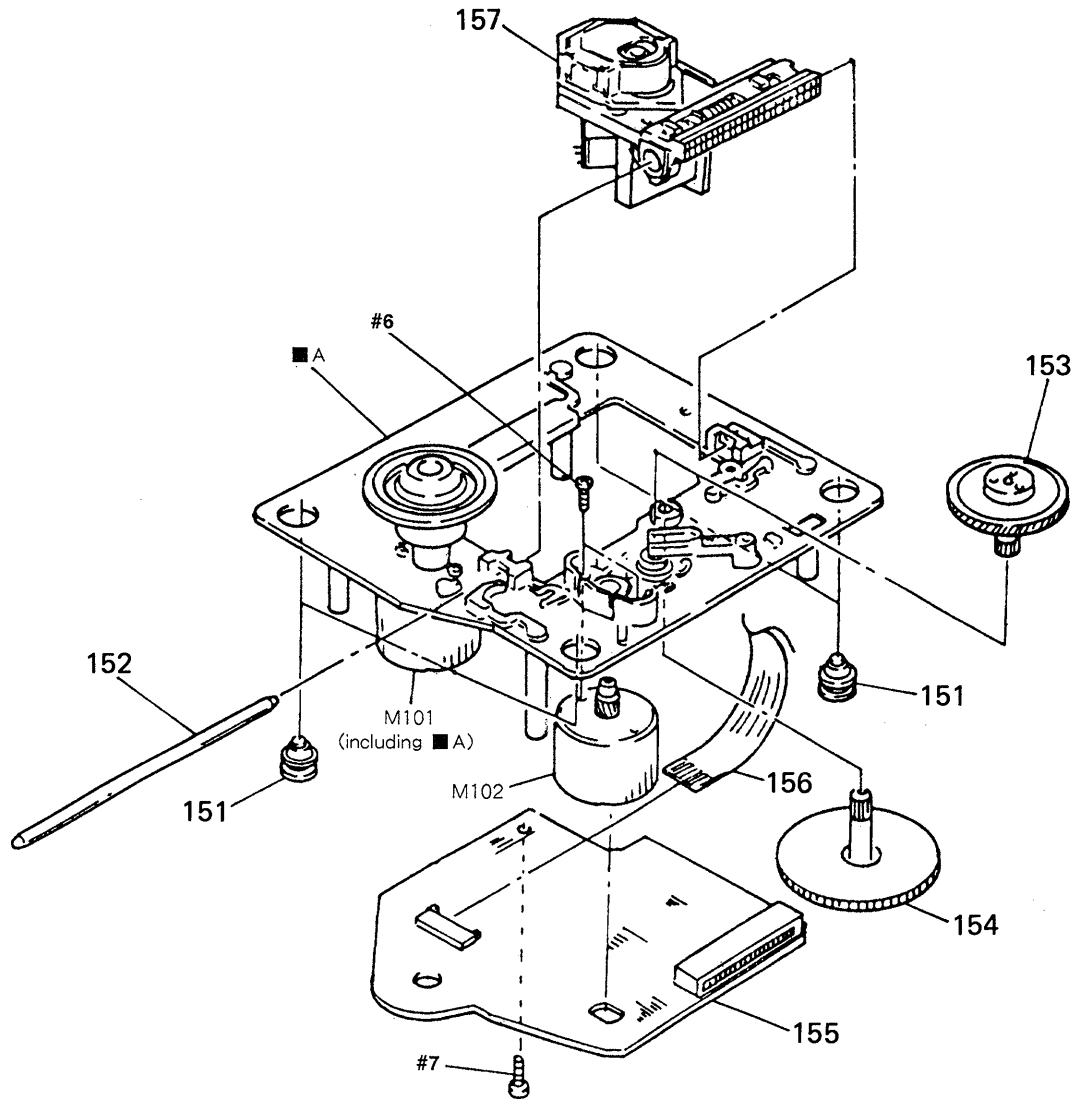

Note: The components identified by mark Δ or dotted line with mark Δ are critical for safety. Replace only with part number specified.

Ref. No.	Part No.	Description	Remark
151	4-933-126-01	INSULATOR (A)	
152	4-917-565-01	SHAFT, SLED	
153	4-917-567-01	GEAR (M)	
154	4-917-564-01	GEAR (P), FLATNESS	
* 155	A-4617-977-A	BD BOARD, COMPLETE	

Ref. No.	Part No.	Description	Remark
156	1-575-001-11	WIRE, FLAT TYPE (12 CORE)	
Δ 157	8-848-144-11	DEVICE, OPTICAL KSS-240A	
M101	X-4917-523-3	MOTOR ASSY (SPINDLE)	
M102	X-4917-504-1	MOTOR ASSY (SLED)	

SECTION 6 ELECTRICAL PARTS LIST

BD

NOTE:

- Due to standardization, replacements in the parts list may be different from the parts specified in the diagrams or the components used on the set.
- -XX, -X mean standardized parts, so they may have some difference from the original one.
- RESISTORS
All resistors are in ohms
METAL: Metal-film resistor
METAL OXIDE: Metal oxide-film resistor
F: nonflammable

- Items marked "*" are not stocked since they are seldom required for routine service. Some delay should be anticipated when ordering these items.
- SEMICONDUCTORS
In each case, u: μ , for example:
uA.....: μ A....., uPA.....: μ PA.....
uPB.....: μ PB....., uPC.....: μ PC.....
uPD.....: μ PD.....
- CAPACITORS
uF: μ F
uH: μ H

The components identified by mark **A** or dotted line with mark **A** are critical for safety. Replace only with part number specified.

When indicating parts by reference number, please include the board.

Ref.No.	Part No.	Description	Remark		Ref.No.	Part No.	Description	Remark
*	A-4617-977-A	BD BOARD, COMPLETE					< RESISTOR >	

		< CAPACITOR >						
C101	1-163-005-11	CERAMIC CHIP	470PF	10%	50V	R101	1-216-077-00 METAL CHIP	15K 5% 1/10W
C102	1-163-038-00	CERAMIC CHIP	0.1uF		25V	R102	1-216-097-00 METAL CHIP	100K 5% 1/10W
C103	1-163-005-11	CERAMIC CHIP	470PF	10%	50V	R103	1-216-077-00 METAL CHIP	15K 5% 1/10W
C104	1-164-505-11	CERAMIC CHIP	2.2uF		16V	R104	1-216-085-00 METAL CHIP	33K 5% 1/10W
C105	1-135-155-21	TANTALUM CHIP	4.7uF	10%	16V	R105	1-216-097-00 METAL CHIP	100K 5% 1/10W
C106	1-164-346-11	CERAMIC CHIP	1uF		16V	R112	1-216-049-00 METAL CHIP	1K 5% 1/10W
C107	1-164-505-11	CERAMIC CHIP	2.2uF		16V	R113	1-216-077-00 METAL CHIP	15K 5% 1/10W
C108	1-164-346-11	CERAMIC CHIP	1uF		16V	R114	1-216-077-00 METAL CHIP	15K 5% 1/10W
C112	1-163-038-00	CERAMIC CHIP	0.1uF		25V	R117	1-216-077-00 METAL CHIP	15K 5% 1/10W
C151	1-163-007-11	CERAMIC CHIP	680PF	10%	50V	R118	1-216-077-00 METAL CHIP	15K 5% 1/10W
C152	1-163-007-11	CERAMIC CHIP	680PF	10%	50V	R121	1-216-077-00 METAL CHIP	15K 5% 1/10W
C153	1-163-038-00	CERAMIC CHIP	0.1uF		25V	R122	1-216-077-00 METAL CHIP	15K 5% 1/10W
C154	1-164-336-11	CERAMIC CHIP	0.33uF		25V	R151	1-216-070-00 METAL CHIP	7.5K 5% 1/10W
C155	1-163-007-11	CERAMIC CHIP	680PF	10%	50V	R152	1-216-070-00 METAL CHIP	7.5K 5% 1/10W
C156	1-163-007-11	CERAMIC CHIP	680PF	10%	50V	R153	1-216-070-00 METAL CHIP	7.5K 5% 1/10W
C157	1-163-037-11	CERAMIC CHIP	0.022uF	10%	25V	R154	1-216-070-00 METAL CHIP	7.5K 5% 1/10W
C158	1-163-037-11	CERAMIC CHIP	0.022uF	10%	25V	R155	1-216-070-00 METAL CHIP	7.5K 5% 1/10W
C159	1-163-023-00	CERAMIC CHIP	0.015uF	5%	50V	R156	1-216-070-00 METAL CHIP	7.5K 5% 1/10W
C160	1-163-019-00	CERAMIC CHIP	0.0068uF	10%	50V	R157	1-216-085-00 METAL CHIP	33K 5% 1/10W
C181	1-163-038-00	CERAMIC CHIP	0.1uF		25V	R158	1-216-076-00 METAL CHIP	13K 5% 1/10W
		< CONNECTOR >				R159	1-216-085-00 METAL CHIP	33K 5% 1/10W
CN101	1-568-796-11	SOCKET, CONNECTOR 22P				R160	1-216-081-00 METAL CHIP	22K 5% 1/10W
CN102	1-568-795-11	SOCKET, CONNECTOR 12P				R161	1-216-093-00 METAL CHIP	68K 5% 1/10W
CN103	1-564-721-11	PIN, CONNECTOR (SMALL TYPE) 5P				R162	1-216-085-00 METAL CHIP	33K 5% 1/10W
		< IC >				R163	1-216-308-00 METAL CHIP	4.7 5% 1/10W
IC101	8-752-344-48	IC CXD2501Q				R181	1-216-021-00 METAL CHIP	68 5% 1/10W
IC102	8-759-071-80	IC BA6297APP-T1				R182	1-216-021-00 METAL CHIP	68 5% 1/10W
IC103	8-759-040-83	IC BA6287F-T1					< SWITCH >	
						S101	1-572-085-11 SWITCH, LEAF	

DISP **HP**

Ref.No.	Part No.	Description	Remark
*	A-4649-122-A	DISP BOARD, COMPLETE(M34) *****	
*	A-4649-127-A	DISP BOARD, COMPLETE(M44) *****	
*	4-923-103-01	HOLDER, FL TUBE < CAPACITOR >	
C401	1-164-159-11	CERAMIC 0.1uF 50V	
C402	1-164-159-11	CERAMIC 0.1uF 50V	
C403	1-124-261-00	ELECT 10uF 20% 50V	
C404	1-124-261-00	ELECT 10uF 20% 50V	
		< CONNECTOR >	
CN401	1-535-883-11	JUMPER, FILM (WITH TERMINAL) < DIODE >	
D401	8-719-987-63	DIODE 1N4148M	
D402	8-719-987-63	DIODE 1N4148M	
D403	8-719-987-63	DIODE 1N4148M	
D404	8-719-987-63	DIODE 1N4148M	
D405	8-719-987-63	DIODE 1N4148M	
D406	8-719-987-63	DIODE 1N4148M	
D407	8-719-987-63	DIODE 1N4148M	
D408	8-719-987-63	DIODE 1N4148M	
D409	8-719-987-63	DIODE 1N4148M	
D412	8-719-121-24	DIODE RD9.1ES-L	
		< FILTER >	
FLD401	1-519-611-11	INDICATOR TUBE, FLUORESCENT < IC >	
IC401	8-759-046-57	IC uPD75216ACW-C69	
IC402	8-749-920-83	IC GP1U52XB	
		< RESISTOR >	
R401	1-249-435-11	CARBON 33K 5% 1/4W	
R402	1-249-435-11	CARBON 33K 5% 1/4W	
R403	1-249-435-11	CARBON 33K 5% 1/4W	
R404	1-249-435-11	CARBON 33K 5% 1/4W	
R405	1-249-435-11	CARBON 33K 5% 1/4W	
R406	1-249-425-11	CARBON 4.7K 5% 1/4W	
R407	1-249-425-11	CARBON 4.7K 5% 1/4W	
R408	1-249-439-11	CARBON 68K 5% 1/4W	
		< SWITCH >	
S401	1-554-303-21	SWITCH, TACTILE (■)	
S402	1-554-303-21	SWITCH, TACTILE (▶▶, ▶▶▶)	

Ref.No.	Part No.	Description	Remark
S403	1-554-303-21	SWITCH, TACTILE (◀◀, ▶▶)	
S404	1-554-303-21	SWITCH, TACTILE (REPEAT)	
S405	1-554-303-21	SWITCH, TACTILE (TIME)	
S406	1-554-303-21	SWITCH, TACTILE (FADER)	
S407	1-554-303-21	SWITCH, TACTILE (SHUFFLE)	
S408	1-554-303-21	SWITCH, TACTILE (PROGRAM)	
S409	1-554-303-21	SWITCH, TACTILE (CONTINUE)	
S410	1-554-303-21	SWITCH, TACTILE (II)	
S411	1-554-303-21	SWITCH, TACTILE (▲ OPEN/CLOSE)	
S412	1-554-303-21	SWITCH, TACTILE (▶)	
S413	1-554-303-21	SWITCH, TACTILE (1)	
S414	1-554-303-21	SWITCH, TACTILE (11)	
S415	1-554-303-21	SWITCH, TACTILE (6)	
S416	1-554-303-21	SWITCH, TACTILE (2)	
S417	1-554-303-21	SWITCH, TACTILE (12)	
S418	1-554-303-21	SWITCH, TACTILE (EDIT/TIME FADE)	
S419	1-554-303-21	SWITCH, TACTILE (7)	
S420	1-554-303-21	SWITCH, TACTILE (3)	
S421	1-554-303-21	SWITCH, TACTILE (CHECK)	
S422	1-554-303-21	SWITCH, TACTILE (8)	
S423	1-554-303-21	SWITCH, TACTILE (5)	
S424	1-554-303-21	SWITCH, TACTILE (>12)	
S425	1-554-303-21	SWITCH, TACTILE (P. SEARCH)	
S426	1-554-303-21	SWITCH, TACTILE (10)	
S427	1-554-303-21	SWITCH, TACTILE (4)	
S428	1-554-303-21	SWITCH, TACTILE (CLEAR)	
S429	1-554-303-21	SWITCH, TACTILE (MUSIC SCAN)	
S430	1-554-303-21	SWITCH, TACTILE (9)	
		< CRYSTAL >	
X401	1-577-358-21	VIBRATOR, CERAMIC (4MHz)	

*	1-642-426-11	HP BOARD(M44) *****	
		< CAPACITOR >	
C481	1-162-294-31	CERAMIC 0.001uF 10% 50V (M44)	
C482	1-162-294-31	CERAMIC 0.001uF 10% 50V (M44)	
C483	1-164-159-11	CERAMIC 0.1uF 50V (M44)	
		< JACK >	
J481	1-568-519-41	JACK, LARGE TYPE	(M44)

HP **LOADING** **MAIN**

Ref.No.	Part No.	Description	Remark		
< RESISTOR >					
R481	1-249-402-11	CARBON	56	5%	1/4W (M44)
R482	1-249-402-11	CARBON	56	5%	1/4W (M44)

*	1-632-202-11	LOADING BOARD	*****		
< CONNECTOR >					
* CN301	1-564-707-11	PIN, CONNECTOR (SMALL TYPE) 5P			
< SWITCH >					
S271	1-572-086-11	SWITCH, LEAF			
S272	1-572-086-11	SWITCH, LEAF			

*	A-4649-124-A	MAIN BOARD, COMPLETE(M34:AEP)	*****		
*	A-4649-125-A	MAIN BOARD, COMPLETE(M34:E, Saudi Arabia)	*****		
*	A-4649-130-A	MAIN BOARD, COMPLETE(M44)	*****		
4-902-345-01 HEAT SINK					
7-682-547-09 SCREW +B 3X6					
< CAPACITOR >					
C201	1-124-572-11	ELECT	100uF	20%	63V
C202	1-126-059-11	ELECT	10uF	20%	50V
C203	1-124-360-00	ELECT	1000uF	20%	16V
C204	1-126-937-11	ELECT	4700uF	20%	16V
C205	1-126-163-11	ELECT	4.7uF	20%	50V
C206	1-126-059-11	ELECT	10uF	20%	50V
C207	1-126-059-11	ELECT	10uF	20%	50V
C208	1-124-997-11	ELECT	470uF	20%	10V
C209	1-124-997-11	ELECT	470uF	20%	10V
C211	1-124-997-11	ELECT	470uF	20%	10V
C214	1-126-023-11	ELECT	100uF	20%	16V
C221	1-164-159-11	CERAMIC	0.1uF		50V
C301	1-126-022-11	ELECT	47uF	20%	16V
C302	1-126-301-11	ELECT	1uF	20%	50V
C303	1-164-159-11	CERAMIC	0.1uF		50V
C304	1-164-159-11	CERAMIC	0.1uF		50V
C305	1-126-022-11	ELECT	47uF	20%	16V
C306	1-164-159-11	CERAMIC	0.1uF		50V
C307	1-164-159-11	CERAMIC	0.1uF		50V
C308	1-164-159-11	CERAMIC	0.1uF		50V

Ref.No.	Part No.	Description	Remark		
C309	1-164-159-11	CERAMIC	0.1uF		50V
C311	1-130-491-00	MYLAR	0.047uF	5%	50V
C312	1-161-374-11	CERAMIC	0.0015uF	20%	50V
C313	1-161-494-00	CERAMIC	0.022uF		25V
C314	1-162-306-11	CERAMIC	0.01uF	20%	16V
C315	1-126-300-11	ELECT	0.47uF	20%	50V
C316	1-161-494-00	CERAMIC	0.022uF		25V
C317	1-164-159-11	CERAMIC	0.1uF		50V
C319	1-162-282-31	CERAMIC	100PF	10%	50V
C320	1-130-483-00	MYLAR	0.01uF	5%	50V
C321	1-162-208-31	CERAMIC	24PF	5%	50V
C322	1-126-022-11	ELECT	47uF	20%	16V
C323	1-164-159-11	CERAMIC	0.1uF		50V
C324	1-164-159-11	CERAMIC	0.1uF		50V
C325	1-162-205-31	CERAMIC	18PF	5%	50V
C326	1-162-205-31	CERAMIC	18PF	5%	50V
C327	1-161-494-00	CERAMIC	0.022uF		25V
C328	1-126-059-11	ELECT	10uF	20%	50V
C329	1-126-022-11	ELECT	47uF	20%	16V
C331	1-161-494-00	CERAMIC	0.022uF		25V
C332	1-164-159-11	CERAMIC	0.1uF		50V
C333	1-162-294-31	CERAMIC	0.001uF	10%	50V
C351	1-126-022-11	ELECT	47uF	20%	16V
C352	1-164-159-11	CERAMIC	0.1uF		50V
C353	1-126-022-11	ELECT	47uF	20%	16V
C354	1-161-494-00	CERAMIC	0.022uF		25V
C355	1-126-022-11	ELECT	47uF	20%	16V
C356	1-164-159-11	CERAMIC	0.1uF		50V
C357	1-130-495-00	MYLAR	0.1uF	5%	50V
C358	1-130-495-00	MYLAR	0.1uF	5%	50V
C361	1-162-280-31	CERAMIC	82PF	10%	50V
C362	1-162-280-31	CERAMIC	82PF	10%	50V
C363	1-162-213-31	CERAMIC	39PF	5%	50V
C364	1-162-213-31	CERAMIC	39PF	5%	50V
C365	1-162-213-31	CERAMIC	39PF	5%	50V
C366	1-162-213-31	CERAMIC	39PF	5%	50V
C367	1-161-494-00	CERAMIC	0.022uF		25V
C368	1-161-494-00	CERAMIC	0.022uF		25V
C371	1-130-479-00	MYLAR	0.0047uF	5%	50V
C372	1-130-479-00	MYLAR	0.0047uF	5%	50V
C373	1-130-472-00	MYLAR	0.0012uF	5%	50V
C374	1-130-472-00	MYLAR	0.0012uF	5%	50V
C377	1-126-022-11	ELECT	47uF	20%	16V
C378	1-126-022-11	ELECT	47uF	20%	16V
C379	1-130-473-00	MYLAR	0.0015uF	5%	50V
C380	1-130-473-00	MYLAR	0.0015uF	5%	50V

MAIN

Ref. No.	Part No.	Description	Remark	Ref. No.	Part No.	Description	Remark
		< CONNECTOR >					
* CN201	1-580-230-11	PIN, CONNECTOR (PC BOARD)	3P	Q371	8-729-141-30	TRANSISTOR 2SC3623A-LK	
* CN301	1-568-822-11	SOCKET, CONNECTOR 22P		Q372	8-729-141-30	TRANSISTOR 2SC3623A-LK	
* CN302	1-568-843-11	SOCKET, CONNECTOR 28P		Q373	8-729-141-30	TRANSISTOR 2SC3623A-LK	
* CN381	1-568-832-11	SOCKET, CONNECTOR 13P	(M44)	Q374	8-729-141-30	TRANSISTOR 2SC3623A-LK	
* CN382	1-564-708-11	PIN, CONNECTOR (SMALL TYPE)	6P(M34)	Q375	8-729-231-55	TRANSISTOR 2SC2878-AB	
		< DIODE >		Q376	8-729-231-55	TRANSISTOR 2SC2878-AB	
D201	8-719-200-82	DIODE 11ES2				< RESISTOR >	
D202	8-719-110-03	DIODE RD7. 5ES-B2		R201	1-249-435-11	CARBON 33K 5% 1/4W	
D203	8-719-200-82	DIODE 11ES2		R202	1-249-438-11	CARBON 56K 5% 1/4W	
D204	8-719-200-82	DIODE 11ES2		R203	1-249-429-11	CARBON 10K 5% 1/4W	
D205	8-719-200-82	DIODE 11ES2		R204	1-249-425-11	CARBON 4. 7K 5% 1/4W	
				R205	1-249-425-11	CARBON 4. 7K 5% 1/4W	
D206	8-719-200-82	DIODE 11ES2		R208	1-249-423-11	CARBON 3. 3K 5% 1/4W	
D208	8-719-109-89	DIODE RD5. 6ES-B2		R209	1-249-413-11	CARBON 470 5% 1/4W	
D209	8-719-987-63	DIODE 1N4148M		R214	1-249-417-11	CARBON 1K 5% 1/4W	
D328	8-719-987-63	DIODE 1N4148M		R301	1-249-417-11	CARBON 1K 5% 1/4W	
D344	8-719-987-63	DIODE 1N4148M		R302	1-249-417-11	CARBON 1K 5% 1/4W	
		< IC >		R303	1-249-421-11	CARBON 2. 2K 5% 1/4W	
IC201	8-759-633-42	IC M5293L		R304	1-249-417-11	CARBON 1K 5% 1/4W	
IC202	8-759-630-21	IC M5290P-16		R306	1-249-413-11	CARBON 470 5% 1/4W	
IC204	8-759-604-86	IC M5F7807		R309	1-249-405-11	CARBON 100 5% 1/4W	
IC301	8-752-337-26	IC CXD2500AQ		R311	1-249-423-11	CARBON 3. 3K 5% 1/4W	
IC302	8-752-342-65	IC CXD2560M		R312	1-249-429-11	CARBON 10K 5% 1/4W	
				R313	1-249-423-11	CARBON 3. 3K 5% 1/4W	
IC303	8-752-349-01	IC CXD2561AM		R314	1-249-429-11	CARBON 10K 5% 1/4W	
IC306	8-759-503-91	IC TL082ACP		R315	1-249-417-11	CARBON 1K 5% 1/4W	
IC307	8-759-945-58	IC RC4558P		R316	1-249-417-11	CARBON 1K 5% 1/4W	
		< JACK >		R317	1-249-419-11	CARBON 1. 5K 5% 1/4W	
J381	1-569-442-11	JACK, PIN 2P(M34)		R318	1-249-441-11	CARBON 100K 5% 1/4W	
* J381	1-569-443-11	JACK, PIN 4P(M44)		R319	1-247-903-00	CARBON 1M 5% 1/4W	
		< COIL >		R320	1-249-417-11	CARBON 1K 5% 1/4W	
L306	1-408-403-00	INDUCTOR 3. 3uH		R321	1-249-417-11	CARBON 1K 5% 1/4W	
L321	1-408-403-00	INDUCTOR 3. 3uH		R322	1-249-417-11	CARBON 1K 5% 1/4W	
		< TRANSISTOR >		R323	1-249-417-11	CARBON 1K 5% 1/4W	
Q201	8-729-119-76	TRANSISTOR 2SA1175-HFE		R324	1-249-417-11	CARBON 1K 5% 1/4W	
Q202	8-729-140-96	TRANSISTOR 2SD774-34		R325	1-249-417-11	CARBON 1K 5% 1/4W	
Q203	8-729-141-83	TRANSISTOR 2SB1094-LK		R326	1-249-417-11	CARBON 1K 5% 1/4W	
Q204	8-729-900-65	TRANSISTOR DTA144ES		R327	1-247-903-00	CARBON 1M 5% 1/4W	
Q205	8-729-900-89	TRANSISTOR DTC144ES		R328	1-249-429-11	CARBON 10K 5% 1/4W	
				R331	1-249-429-11	CARBON 10K 5% 1/4W	
Q206	8-729-900-89	TRANSISTOR DTC144ES		R332	1-249-429-11	CARBON 10K 5% 1/4W	
Q341	8-729-900-65	TRANSISTOR DTA144ES		R333	1-249-429-11	CARBON 10K 5% 1/4W	
Q342	8-729-900-65	TRANSISTOR DTA144ES		R334	1-249-429-11	CARBON 10K 5% 1/4W	
Q343	8-729-900-65	TRANSISTOR DTA144ES		R343	1-249-441-11	CARBON 100K 5% 1/4W	
Q344	8-729-900-89	TRANSISTOR DTC144ES		R344	1-249-441-11	CARBON 100K 5% 1/4W	
				R345	1-249-425-11	CARBON 4. 7K 5% 1/4W	
				R346	1-249-425-11	CARBON 4. 7K 5% 1/4W	

MAIN

MOTOR VR

POWER SW

Ref.No.	Part No.	Description	Remark
R347	1-249-441-11	CARBON	100K 5% 1/4W
R348	1-249-429-11	CARBON	10K 5% 1/4W
R351	1-249-436-11	CARBON	39K 5% 1/4W
R352	1-249-436-11	CARBON	39K 5% 1/4W
R353	1-249-436-11	CARBON	39K 5% 1/4W
R354	1-249-436-11	CARBON	39K 5% 1/4W
R355	1-249-436-11	CARBON	39K 5% 1/4W
R356	1-249-436-11	CARBON	39K 5% 1/4W
R357	1-249-436-11	CARBON	39K 5% 1/4W
R358	1-249-436-11	CARBON	39K 5% 1/4W
R361	1-249-431-11	CARBON	15K 5% 1/4W
R362	1-249-431-11	CARBON	15K 5% 1/4W
R363	1-249-431-11	CARBON	15K 5% 1/4W
R364	1-249-431-11	CARBON	15K 5% 1/4W
R365	1-249-438-11	CARBON	56K 5% 1/4W
R366	1-249-438-11	CARBON	56K 5% 1/4W
R367	1-249-438-11	CARBON	56K 5% 1/4W
R368	1-249-438-11	CARBON	56K 5% 1/4W
R369	1-249-419-11	CARBON	1.5K 5% 1/4W
R370	1-249-419-11	CARBON	1.5K 5% 1/4W
R371	1-249-419-11	CARBON	1.5K 5% 1/4W
R372	1-249-419-11	CARBON	1.5K 5% 1/4W
R373	1-247-887-00	CARBON	220K 5% 1/4W
R374	1-247-887-00	CARBON	220K 5% 1/4W
R375	1-249-409-11	CARBON	220 5% 1/4W
R376	1-249-409-11	CARBON	220 5% 1/4W
R377	1-249-409-11	CARBON	220 5% 1/4W
R378	1-249-409-11	CARBON	220 5% 1/4W
R379	1-249-425-11	CARBON	4.7K 5% 1/4W
R380	1-249-425-11	CARBON	4.7K 5% 1/4W
R381	1-249-425-11	CARBON	4.7K 5% 1/4W
R382	1-249-425-11	CARBON	4.7K 5% 1/4W
R383	1-249-413-11	CARBON	470 5% 1/4W
R384	1-249-413-11	CARBON	470 5% 1/4W
R385	1-249-393-11	CARBON	10 5% 1/4W
R386	1-249-393-11	CARBON	10 5% 1/4W
R389	1-249-413-11	CARBON	470 5% 1/4W (M44)
R390	1-249-413-11	CARBON	470 5% 1/4W (M44)
< SWITCH >			
△S201	1-571-722-11	SWITCH, VOLTAGE SELECTION	(M34:E, Saudi Arabia)
< CRYSTAL >			
X327	1-579-314-11	VIBRATOR, CRYSTAL(22.5792MHZ)	

Ref.No.	Part No.	Description	Remark
*	1-642-427-11	MOTOR VR BOARD(M44)	*****
*	4-922-980-01	HOLDER (LED)	(M44)
< CAPACITOR >			
C451	1-124-994-11	ELECT	100uF 20% 10V (M44)
C452	1-124-994-11	ELECT	100uF 20% 10V (M44)
C471	1-124-994-11	ELECT	100uF 20% 10V (M44)
C472	1-124-277-11	ELECT	4.7uF 20% 35V (M44)
< CONNECTOR >			
* CN451	1-568-832-11	SOCKET, CONNECTOR 13P	(M44)
* CN472	1-568-941-11	PIN, CONNECTOR 3P	(M44)
< DIODE >			
D471	8-719-970-49	DIODE BR4361F	(M44)
< IC >			
IC451	8-759-981-85	IC RC4556D	(M44)
IC471	8-759-962-08	IC BA6208	(M44)
< RESISTOR >			
R451	1-249-435-11	CARBON	33K 5% 1/4W (M44)
R452	1-249-435-11	CARBON	33K 5% 1/4W (M44)
R453	1-249-432-11	CARBON	18K 5% 1/4W (M44)
R454	1-249-432-11	CARBON	18K 5% 1/4W (M44)
R455	1-249-431-11	CARBON	15K 5% 1/4W (M44)
R456	1-249-431-11	CARBON	15K 5% 1/4W (M44)
R457	1-249-438-11	CARBON	56K 5% 1/4W (M44)
R458	1-249-438-11	CARBON	56K 5% 1/4W (M44)
R461	1-249-399-11	CARBON	33 5% 1/4W (M44)
R462	1-249-399-11	CARBON	33 5% 1/4W (M44)
R471	1-249-411-11	CARBON	330 5% 1/4W (M44)
R472	1-249-417-11	CARBON	1K 5% 1/4W (M44)
R473	1-249-417-11	CARBON	1K 5% 1/4W (M44)
< VARIABLE RESISTOR >			
RV451	1-238-974-11	RES, VAR, CARBON 10K/10K	(LINE OUT/PHONE LEVEL) (M44)

*	1-642-429-11	POWER SW BOARD	*****
< CONNECTOR >			
CN491	1-506-469-11	CONNECTOR	4P, MALE

Note: The components identified by mark △ or dotted line with mark △ are critical for safety. Replace only with part number specified.

POWER SW **VOL**

Ref.No.	Part No.	Description	Remark
		< SWITCH >	
S491	1-554-118-00	SWITCH, PUSH (1 KEY)(POWER)	

*	1-642-428-11	VOL BOARD (M34)	

		< CAPACITOR >	
C510	1-124-994-11	ELECT 100uF 20% 10V (M34)	
C511	1-162-290-31	CERAMIC 470PF 10% 50V (M34)	
C520	1-124-994-11	ELECT 100uF 20% 10V (M34)	
C521	1-162-290-31	CERAMIC 470PF 10% 50V (M34)	
C530	1-164-159-11	CERAMIC 0.1uF 50V (M34)	
		< CONNECTOR >	
* CN501	1-564-708-11	PIN, CONNECTOR (SMALL TYPE) 6P (M34)	
		< IC >	
IC501	8-759-981-85	IC RC4556D (M34)	
		< JACK >	
J501	1-568-519-41	JACK, LARGE TYPE (M34)	
		< RESISTOR >	
R510	1-249-435-11	CARBON 33K 5% 1/4W (M34)	
R511	1-249-431-11	CARBON 15K 5% 1/4W (M34)	
R512	1-249-438-11	CARBON 56K 5% 1/4W (M34)	
R513	1-249-402-11	CARBON 56 5% 1/4W (M34)	
R514	1-249-399-11	CARBON 33 5% 1/4W (M34)	
R515	1-249-432-11	CARBON 18K 5% 1/4W (M34)	
R520	1-249-435-11	CARBON 33K 5% 1/4W (M34)	
R521	1-249-431-11	CARBON 15K 5% 1/4W (M34)	
R522	1-249-438-11	CARBON 56K 5% 1/4W (M34)	
R523	1-249-402-11	CARBON 56 5% 1/4W (M34)	
R524	1-249-399-11	CARBON 33 5% 1/4W (M34)	
R525	1-249-432-11	CARBON 18K 5% 1/4W (M34)	
		< VARIABLE RESISTOR >	
RV501	1-241-386-11	RES, VAR, CARBON 20K/20K (LINE OUT/PHONE LEVEL)(M34)	

Ref.No.	Part No.	Description	Remark
		MISCELLANEOUS	

11	1-575-160-11	WIRE, FLAT TYPE (22 CORE)	
* 110	1-452-538-11	MAGNET	
14	1-690-392-11	WIRE, FLAT TYPE (13 CORE)(M44)	
156	1-575-001-11	WIRE, FLAT TYPE (12 CORE)	
△157	8-848-144-11	DEVICE, OPTICAL KSS-240A	
△25	1-574-127-31	CORD, POWER(M34:AEP/M44:AEP)(MADE IN FRANCE)	
△25	1-574-358-31	CORD, POWER(M34:Australian)	
△25	1-574-390-31	CORD, POWER(M44:UK)(MADE IN FRANCE)	
△25	1-575-651-21	CORD, POWER(M34:AEP, Saudi Arabia/M44:AEP) (MADE IN JAPAN)	
△25	1-575-653-21	CORD, POWER(M34:E)(MADE IN JAPAN)	
△26	1-569-007-11	ADAPTER, CONVERSION 2P(M34:E)	
△26	1-569-008-11	ADAPTER, CONVERSION 2P(M34: Saudi Arabia)	
M101	X-4917-523-3	MOTOR ASSY(SPINBLE)	
M102	X-4917-504-1	MOTOR ASSY(SLED)	
M191	A-4604-363-A	MOTOR (L) ASSY	
△PT1	1-449-922-11	TRANSFORMER, POWER(M34/M44:AEP)	
△PT1	1-449-923-11	TRANSFORMER, POWER(M34:E, Saudi Arabia)	

		ACCESSORIES & PACKING MATERIALS	

		1-465-598-11	COMMANDER, REMOTE (RM-D391)(M44)
		1-558-271-11	CORD, CONNECTION(M34:AEP/M44:AEP, UK) (MADE IN FRANCE)
		1-559-533-11	CORD, CONNECTION(M34:AEP, Saudi Arabia/ M44:AEP)(MADE IN JAPAN)
		2-181-754-01	COVER, BATTERY(M44)
		3-754-383-11	MANUAL, INSTRUCTION(ENGLISH, FRENCH, SPANISH, PORTUGESE)
		3-754-383-41	MANUAL, INSTRUCTION(GERMAN, DUTCH, SWEDISH, ITALIAN)(AEP)
*		4-922-998-01	CUSHION(M34:AEP, E, Saudi Arabia/M44:AEP) (MADE IN JAPAN)
*		4-927-355-03	CUSHION(M34:AEP/M44:AEP, UK)(MADE IN FRANCE)
*		4-941-548-01	LABEL, CLASS 1
*		4-948-882-11	INDIVIDUAL CARTON(M44:AEP, UK)(MADE IN FRANCE)
*		4-948-882-21	INDIVIDUAL CARTON(M34:AEP)(MADE IN FRANCE)
*		4-949-971-11	INDIVIDUAL CARTON(M34:AEP, E, Saudi Arabia) (MADE IN JAPAN)
*		4-949-971-51	INDIVIDUAL CARTON(M44:AEP)(MADE IN JAPAN)

Note: The components identified by mark **△** or dotted line with mark **△** are critical for safety. Replace only with part number specified.

Ref. No.	Part No.	Description	Remark
----------	----------	-------------	--------

HARDWARE LIST

#1	7-682-548-09	SCREW +BVTT 3X8 (S)	
#2	7-682-547-04	SCREW +BVTT 3X6 (S)	
#3	7-685-646-79	SCREW +BVTP 3X8 TYPE2 N-S	
#4	7-682-547-09	SCREW +B 3X6	
#5	7-621-775-10	SCREW +B 2.6X4	
#6	7-621-255-15	SCREW +P 2X3	
#7	7-685-134-19	SCREW +BTP 2.6X8 TYPE2 N-S	

