

CDP-M43/M54

SERVICE MANUAL

AEP Model
UK Model
E Model

CDP-M43/M54

Australian Model
CDP-M43

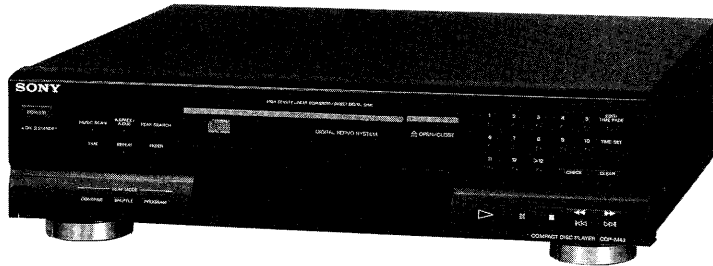

CDP-M43 is the CD player section in
LBT-D507/ D607/ D707,
LBT-A50/A60/A70 series

Photo : CDP-M43

Model Name Using Similar Mechanism	CDP-497/597
CD Mechanism Type	CDM14L-5BD8A
Optical Pick-Up Block Type	BU-5BD8A

SPECIFICATIONS

Compact disc player

Frequency response	2 Hz to 20 kHz \pm 0.5 dB
Signal-to-noise ratio	More than 105 dB CDP-M54 More than 100 dB CDP-M43
Dynamic range	More than 98 dB CDP-M54 More than 92 dB CDP-M43
Harmonic distortion	Less than 0.003% CDP-M54 Less than 0.004% CDP-M43
Channel separation	More than 102 dB CDP-M54 More than 95 dB CDP-M43

Outputs

LINE OUT (FIXED)(phono jacks)	Output level 2 V(at 50 kilohms) Load impedance over 10 kilohms
LINE OUT (VARIABLE)(phono jacks) CDP-M54	Output level max. 2 V(at 50 kilohms) Load impedance over 50 kilohms
PHONES (stereo phone jack) CDP-M54	Output level max. 10 mW Load impedance 32 ohms

General

Power requirements	AEP, East European model : 220 - 230V AC, 50/60Hz UK, Australian model : 240 V AC, 50Hz E, Saudi Arabia, Malaysia model : 110 - 120, 220 - 240V AC, 50/60Hz
--------------------	---

Power consumption	12 W
Dimensions (approx., including projections)	355 \times 95 \times 325 mm(w/h/d) (14 \times 3 $\frac{3}{4}$ \times 12 $\frac{7}{8}$ inches)
Weight (approx.)	3.2 kg(7 lbs 1 oz)
Remote commander	(RM-D597) CDP-M54
Remote control system	Infrared control
Power requirements	3 V DC with two R6 (size AA) batteries
Dimensions (approx., including projections)	40 \times 20 \times 175 mm (w/h/d) (1 $\frac{5}{8}$ \times $\frac{15}{16}$ \times 7 inches)
Weight (approx.)	95 g(4 oz)
Supplied accessories	
Audio cord	(1)(2 Phono plugs-2 phono plugs)
Remote commander	(1) CDP-M54
Sony SUM-3 (NS) batteries	(2) CDP-M54

Design and specifications are subject to change without notice.

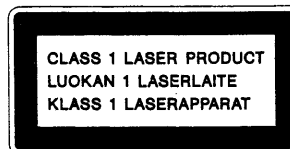



This Compact Disc player is classified as a CLASS 1 LASER product. The CLASS 1 LASER PRODUCT label is located on the rear exterior.

COMPACT DISC PLAYER
SONY®

TABLE OF CONTENTS

<i>Section</i>	<i>Title</i>	<i>Page</i>
	Specifications	1
1. GENERAL		
1-1	Identifying the Parts	4
2. DISASSEMBLY	5
3. ELECTRICAL BLOCK CHECKING	6
4. DIAGRAMS		
4-1	Block Diagram	8
4-2	Circuit Boards Location	10
4-3	Semiconductor Lead Layouts	11
4-4	Printed Wiring Boards	12
4-5	Schematic Diagram	15
4-6	IC Block Diagrams	20
5. EXPLODED VIEWS		
5-1	cabinet section	22
5-2	MD section (CDM14-5BD8A)	24
5-3	Optical Pick-up Block (BU-5BD8A)	25
6. ELECTRICAL PARTS LIST	26

SAFETY-RELATED COMPONENT WARNING!!

COMPONENTS IDENTIFIED BY MARK  OR DOTTED LINE WITH MARK  ON THE SCHEMATIC DIAGRAMS AND IN THE PARTS LIST ARE CRITICAL TO SAFE OPERATION. REPLACE THESE COMPONENTS WITH SONY PARTS WHOSE PART NUMBERS APPEAR AS SHOWN IN THIS MANUAL OR IN SUPPLEMENTS PUBLISHED BY SONY.

MODEL IDENTIFICATION

- Specification Label -

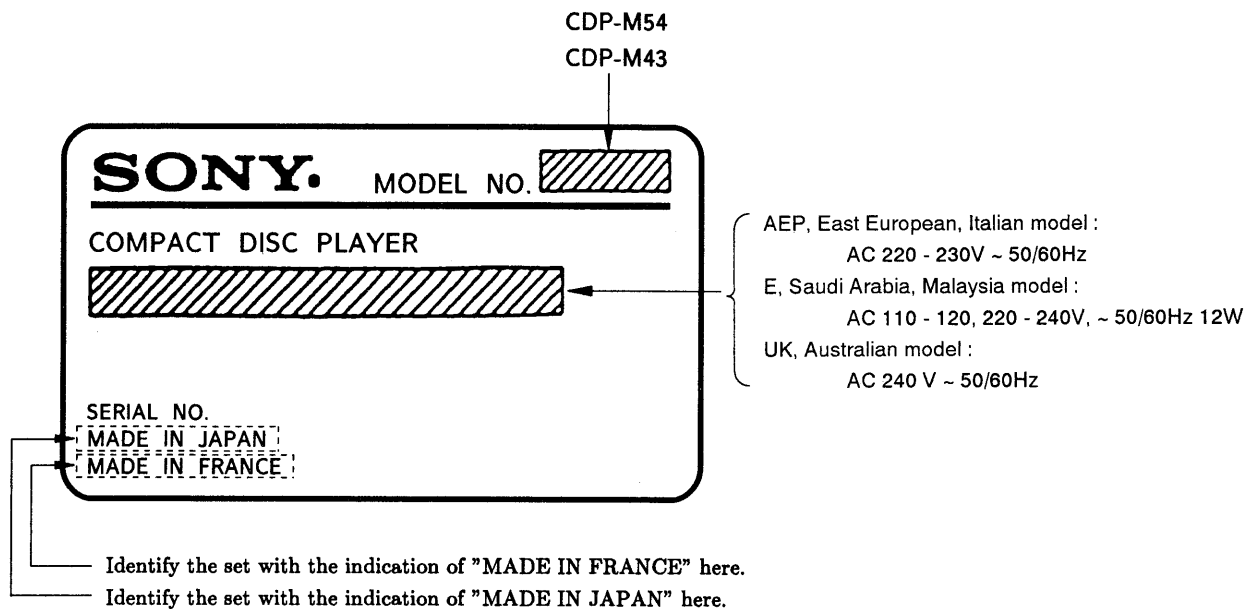
**NOTES ON HANDLING THE OPTICAL PICK-UP BLOCK OR BASE UNIT**

The laser diode in the optical pick-up block may suffer electrostatic breakdown because of the potential difference generated by the charged electrostatic load, etc. on clothing and the human body.

During repair, pay attention to electrostatic breakdown and also use the procedure in the printed matter which is included in the repair parts.

The flexible board is easily damaged and should be handled with care.

NOTES ON LASER DIODE EMISSION CHECK

The laser beam on this model is concentrated so as to be focused on the disc reflective surface by the objective lens in the optical pick-up block. Therefore, when checking the laser diode emission, observe more than 30cm away from the objective lens.

SECTION 1 GENERAL

This section is extracted from instruction manual.

1-1 IDENTIFYING THE PARTS

CDP-M54 model

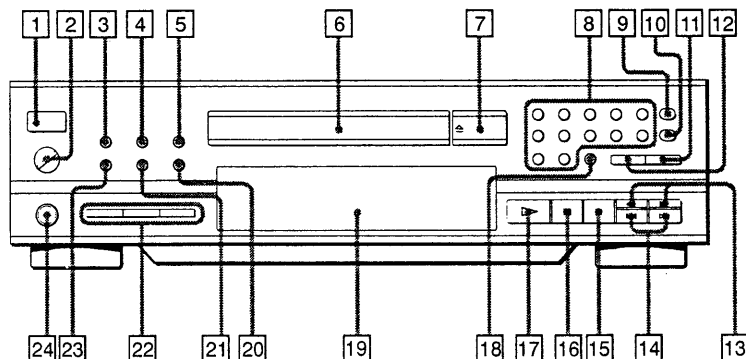

Front Panel

- | | |
|--|---|
| <ul style="list-style-type: none"> 1 POWER switch (20) 2 LINE OUT/PHONE LEVEL control (14) 3 MUSIC SCAN button (40) 4 A.SPACE/A.CUE button (28, 62) 5 PEAK SEARCH button (60) 6 Disc tray (20) 7 ▲ OPEN/CLOSE button (20) 8 Numeric buttons (24, 38, 48, 52) 9 EDIT/TIME FADE button (52, 58) 10 TIME SET button (54, 58) 11 CLEAR (program clear) button (36, 42) 12 CHECK (program check) button (36) 13 ◀▶ (manual search) buttons (26, 46) 14 ◀▶ (AMS*) buttons (24, 48) | <ul style="list-style-type: none"> 15 ■ (stop) button (22) 16 (pause) button (22) 17 ▶ (play) button (22) 18 > 12 (over 12) button (24) 19 Display window (20) 20 FADER button (46) 21 REPEAT button (44) 22 Play mode buttons <ul style="list-style-type: none"> CONTINUE button (30, 34, 38, 56) SHUFFLE button (30, 34, 38, 56) PROGRAM button (34, 48) 23 TIME button (22) 24 PHONES jack |
|--|---|

* AMS is the abbreviation of Automatic Music Sensor.

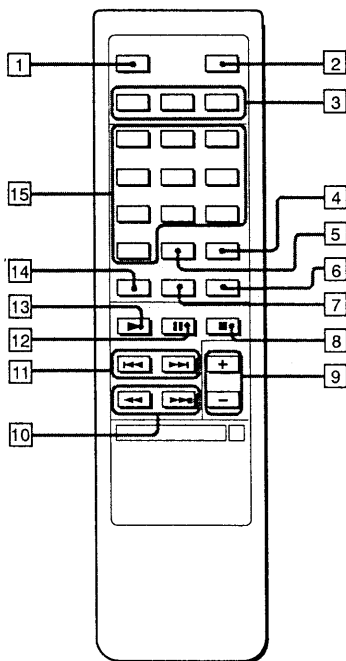

Remote Commander

..... CDP-M54

- 1 A. SPACE/A. CUE button (28, 62)
- 2 MUSIC SCAN button (40)
- 3 Play mode buttons
 - CONTINUE button (30, 34, 38, 56)
 - SHUFFLE button (30, 34, 38, 56)
 - PROGRAM button (34, 48)
- 4 CLEAR (program clear) button (36, 42)
- 5 > 10 (over 10) button (24)
- 6 FADER button (46)
- 7 REPEAT button (44)
- 8 ■ (stop) button (22)
- 9 LINE OUT LEVEL buttons (14)
- 10 ◀▶ (manual search) buttons (26, 46)
- 11 ◀▶ (AMS*) buttons (24, 48)
- 12 || (pause) button (22)
- 13 ▶ (play) button (22)
- 14 TIME button (22)
- 15 Numeric buttons (24, 38, 48, 52)

* AMS is the abbreviation of Automatic Music Sensor.

SECTION 2 DISASSEMBLY

Note :

Follow the disassembly procedure in the numerical order given.

- ❶ Turn the cam to the direction of arrow (Counter clock wise) by minus screw driver.
- ❷ Take off the disc table.
- ❸ Remove the yoke bracket.
- ❹ Remove the MD (BU-5BD8A) to the direction of arrow.

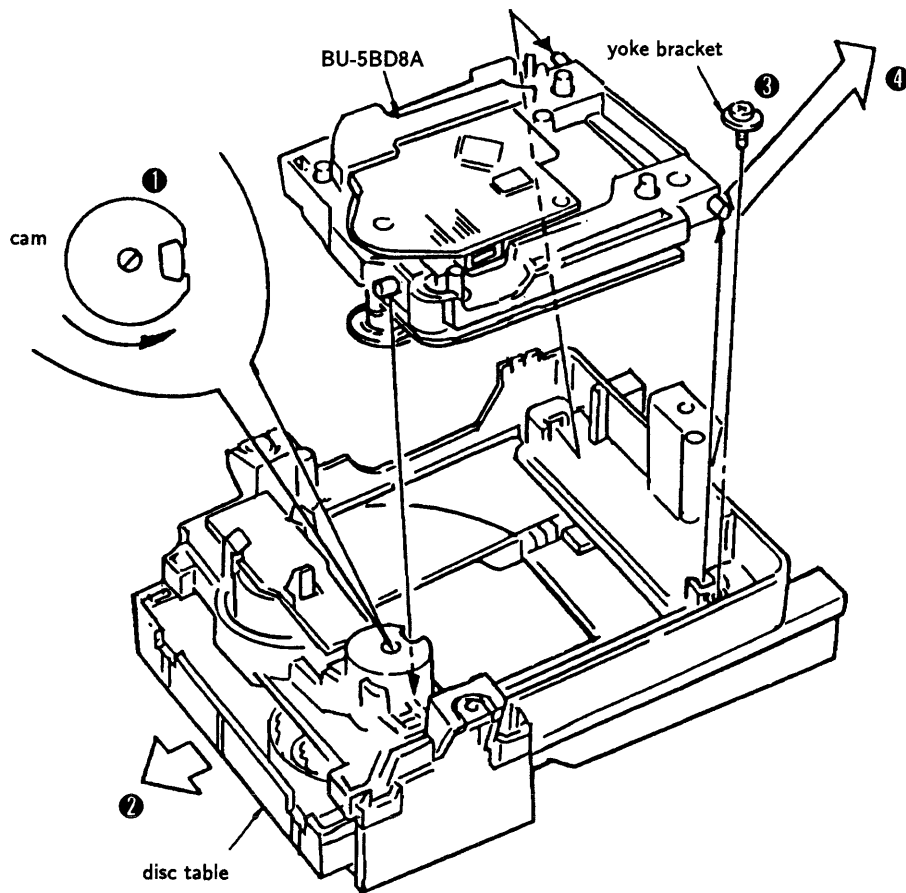

SECTION 3 ELECTRICAL BLOCK CHECKING

Note :

1. CD Block basically constructed to operate with-out adjustment. Therefore, check each item in order given.
2. Use YEDS-18 disc (3-702-101-01) unless otherwise indicated.
3. Use the oscilloscope with more than 10M Ω im-pedance.
4. Clean an object lens by an applicator with neutral detergent when the signal level is low than specified value with the following checks.

S Curve Check

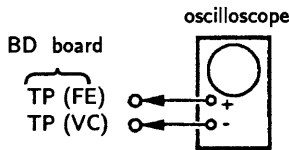

Procedure :

1. Connect oscilloscope to test point TP (FE) on BD board.
2. Connect between test point TP (FEI) and TP (VC) by lead wire.
3. Turned Power switch on and actuate the focus serch. (actuate the focus serch when disc table is moving in and out.)
4. Check the oscilloscope waveform (S curve) is symmetrical between A and B. And confirm peak to peak level within $3 \pm 1V_{p-p}$.

S curve waveform

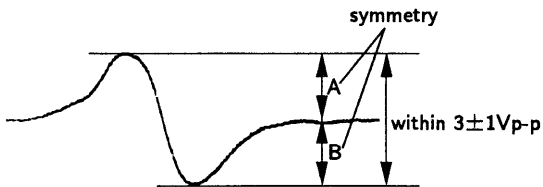

5. After check, remove the lead wire connected in step 2.

Note :

- Try to measure several times to make sure that the ratio of A : B or B : A is more than 10 : 7.
- Take sweep time as long as possible and light up the brightness to obtain best waveform.

RF Level Check

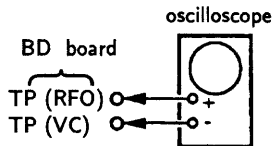

Procedure :

1. Connect oscilloscope to test point TP (RFO) on BD board.
2. Turn Power switch on.
3. Put disc (YEDS-18) in and playback.
4. Confirm that oscilloscope waveform is clear and check RF signal level is correct or not.

Note :

Clear RF signal waveform means that the shape "◇" can be clearly distinguished at the center of the waveform.

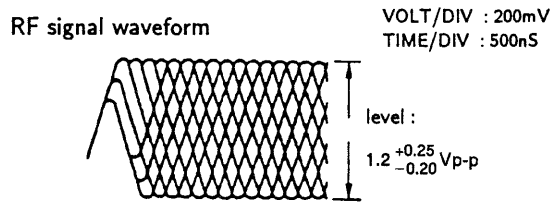

E-F Balance Check

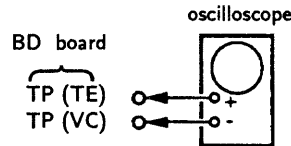

Procedure :

1. Connect test point TP (ADJ) to ground and TP (TEI) to TP (VC) with lead wire.
2. Connect oscilloscope to test point TP (TE) on BD board.
3. Turn Power switch on.
4. Put disc (YEDS-18) in and playback.
5. Confirm that the osilloscope waveform is sym-metrical on the top and bottom in relation to 0V, and check this level.

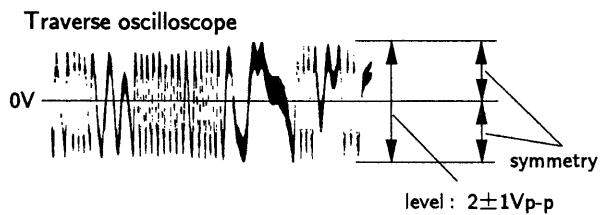

6. Remove the lead wire connected in step 1.

RF PLL Free-run Frequency Check

Procedure :

1. Connect frequency counter to test point (PLCK) with lead wire.

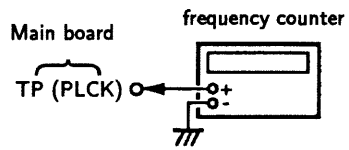

2. Turn Power switch on.
3. Confirm that reading on frequency counter is 4.3218 MHz.

Adjustment Location :

【BD BOARD】

- Solder side -

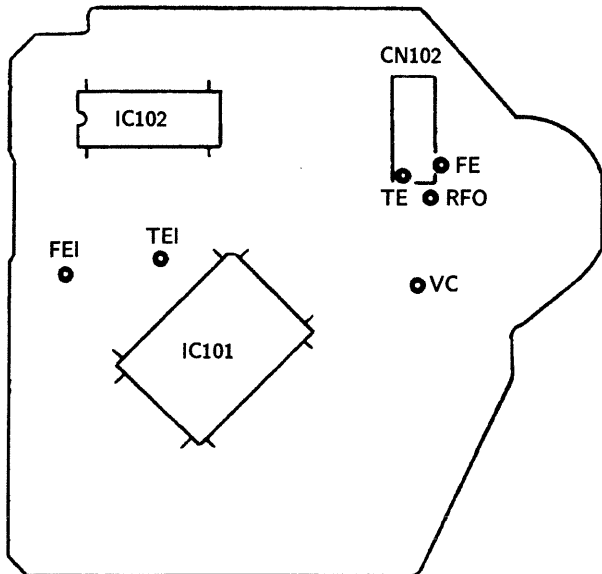

【MAIN BOARD】

- Component side -

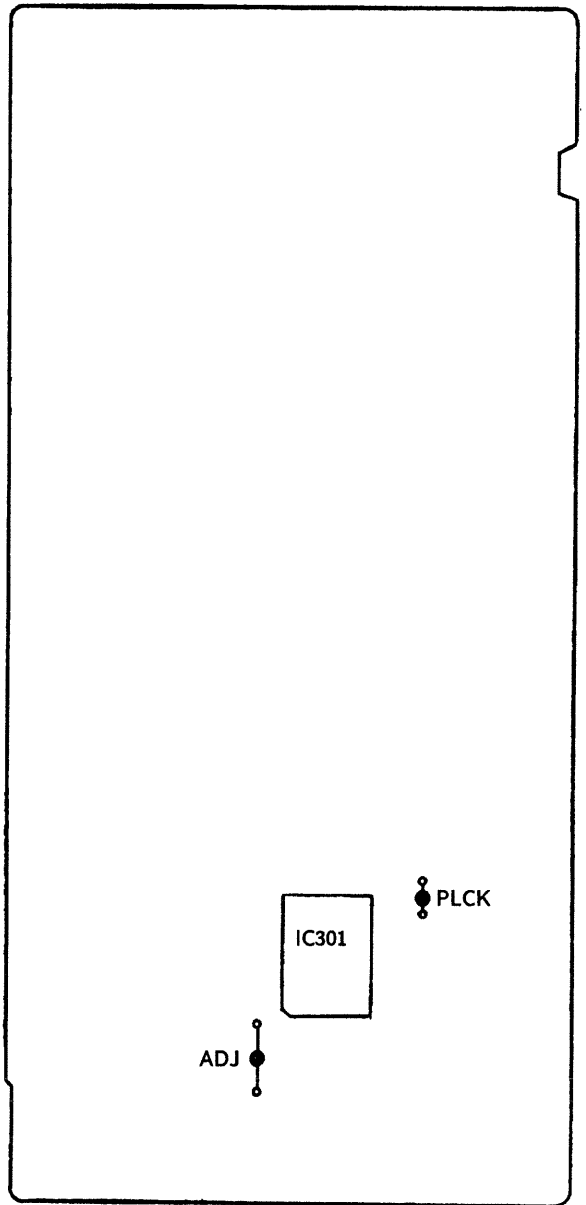

SECTION 4 DIAGRAMS

4-1 BLOCK DIAGRAM

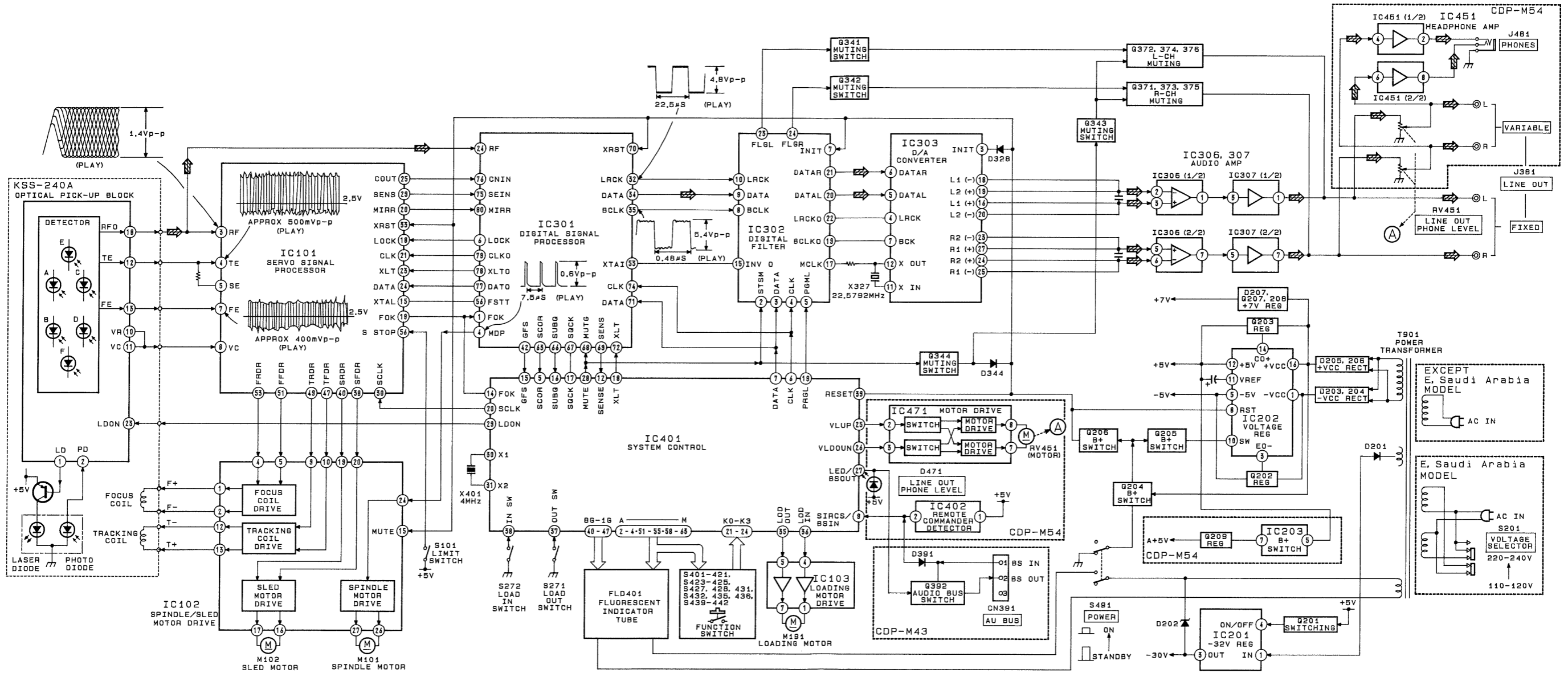

4-2 CIRCUIT BOARDS LOCATION

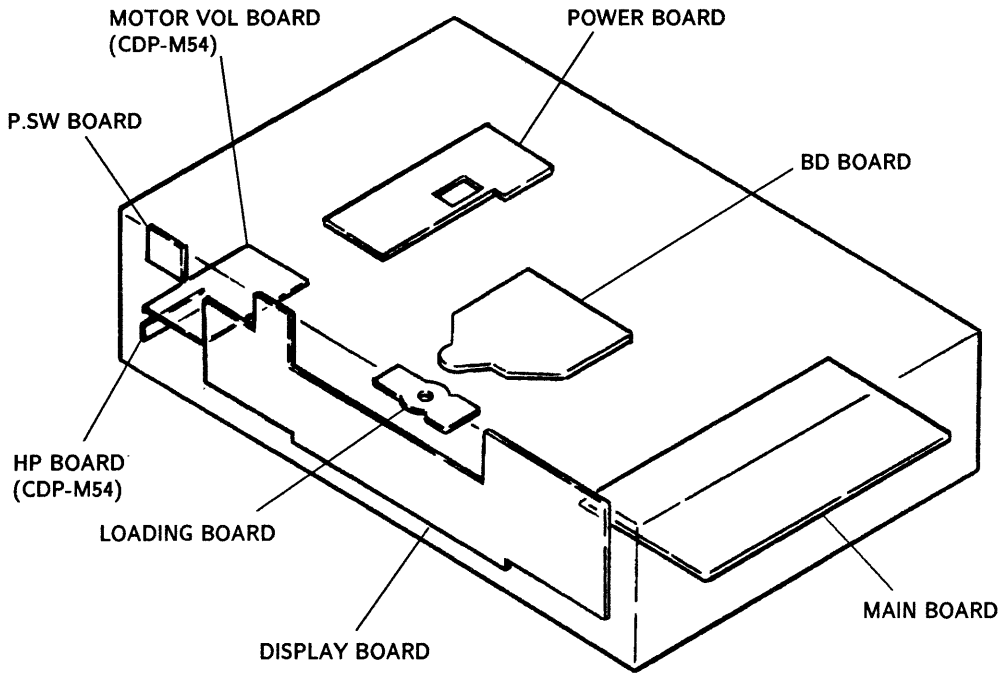

4-3 SEMICONDUCTOR LEAD LAYOUTS

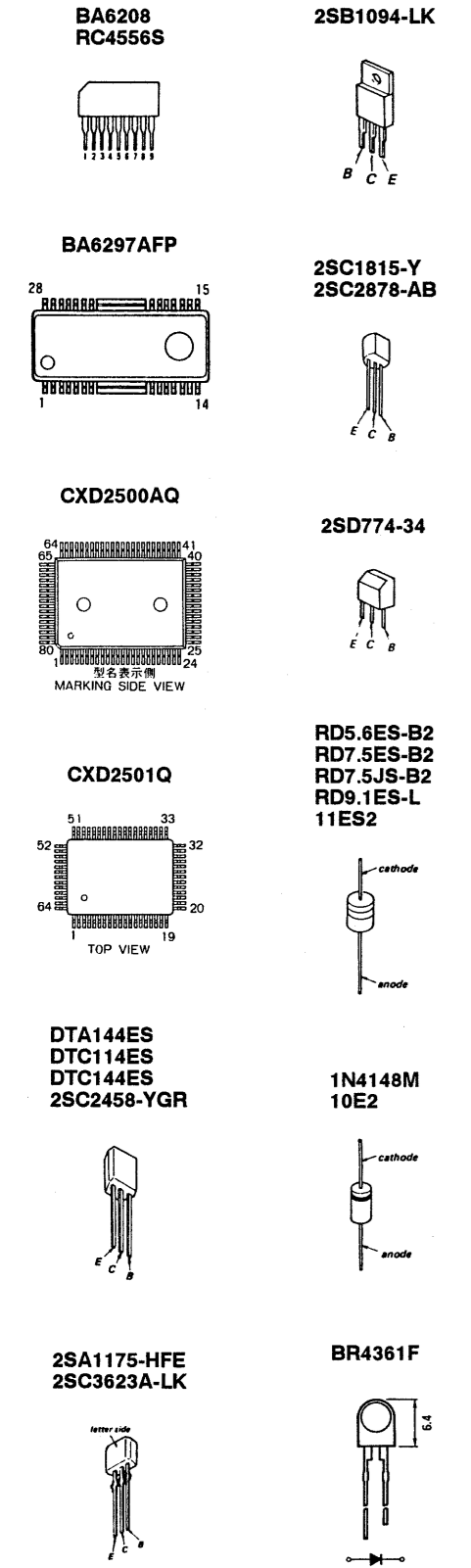

SEMICONDUCTOR LOCATION

Ref. No.	Location	Ref. No.	Location
D201	J-16	IC203	B-7
D202	J-15	IC301	D-12
D203	I-16	IC302	D-10
D204	I-16	IC303	D-9
D205	I-16	IC306	D-7
D206	I-16	IC307	D-6
D207	B-10	IC401	H-6
D208	B-6	IC402	G-9
D209	B-6	IC451	B-2
D328	E-10	IC471	B-3
D344	D-11		
D391	E-5	Q201	J-15
D401	H-12	Q202	B-8
D402	H-12	Q203	C-8
D403	H-12	Q204	B-11
D404	H-11	Q205	C-11
D405	H-11	Q206	C-11
D406	H-11	Q207	B-10
D407	I-13	Q208	B-10
D408	H-11	Q209	C-6
		Q341	E-7
D409	H-10		
D410	H-10	Q342	E-7
D411	H-10	Q343	E-7
D412	H-7	Q344	D-11
D471	D-3	Q371	D-6
		Q372	B-6
IC101	C-16	Q373	D-5
IC102	B-16	Q374	B-6
IC103	B-17	Q375	D-5
IC201	J-15	Q376	B-6
IC202	B-8	Q392	D-5

Note :
 • : parts extracted from the component side.
 • : parts mounted on the conductor side.
 • : Through hole.
 • : Pattern on the side which is seen.
 • : Pattern of the rear side.

4-4 PRINTED WIRING BOARDS

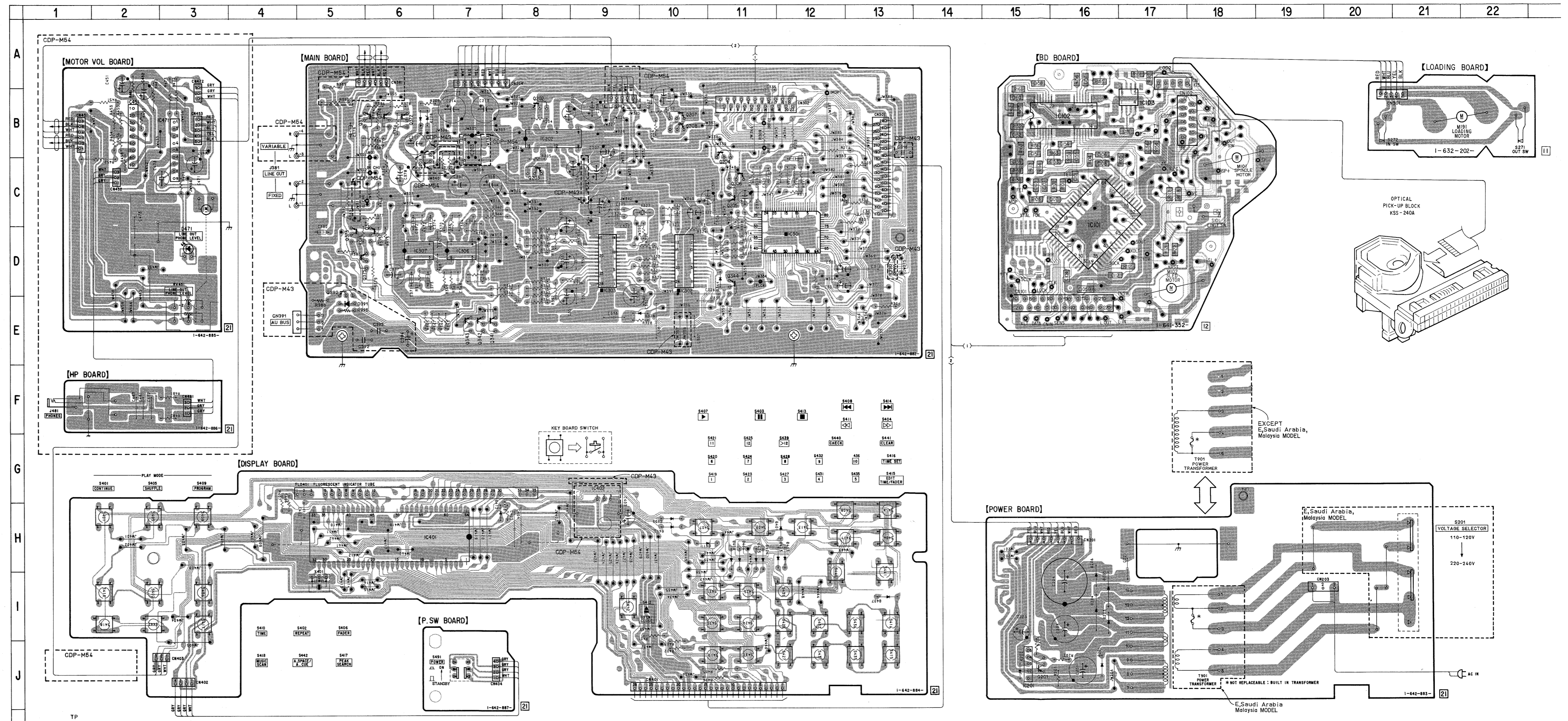

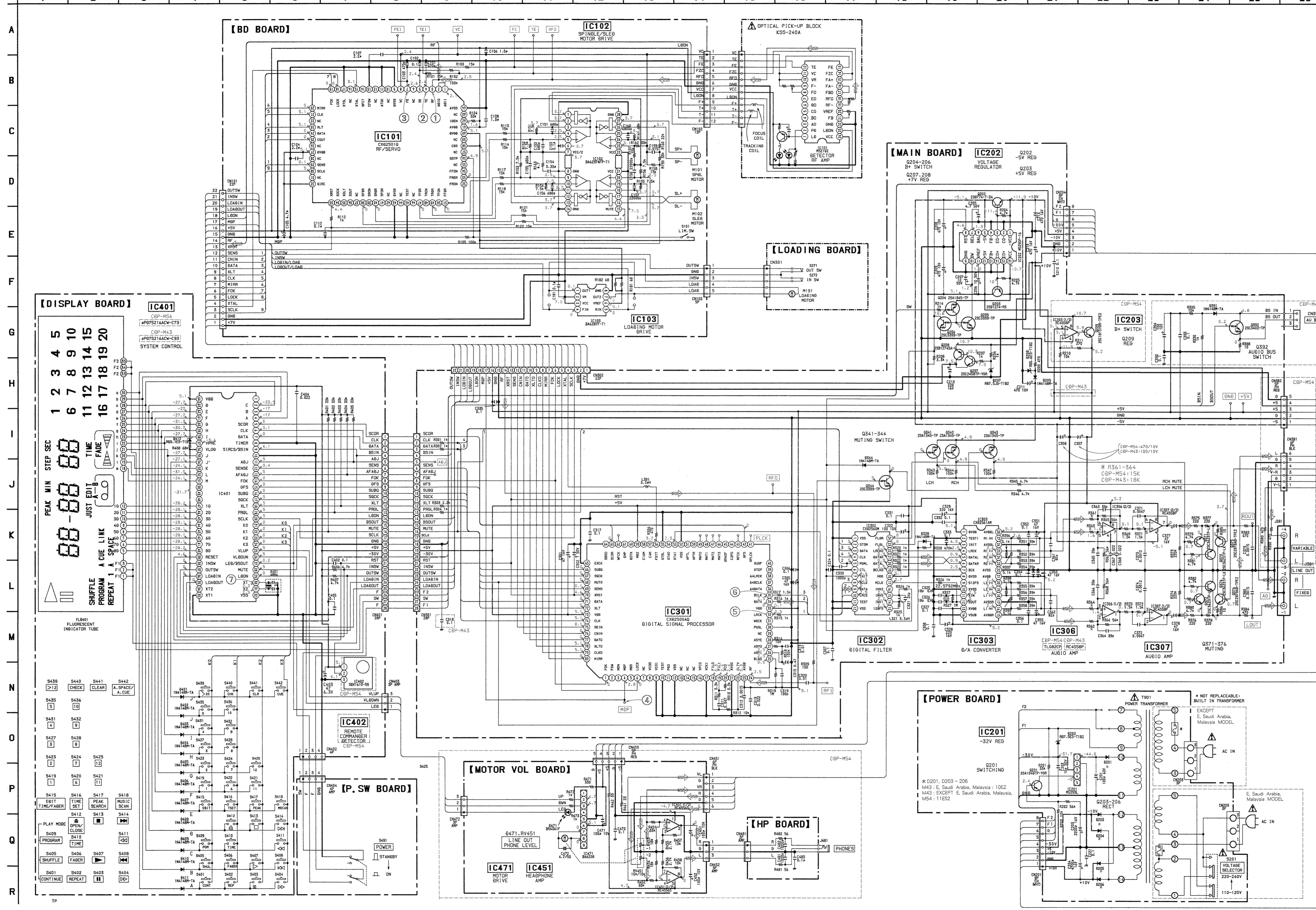

WAVEFORMS

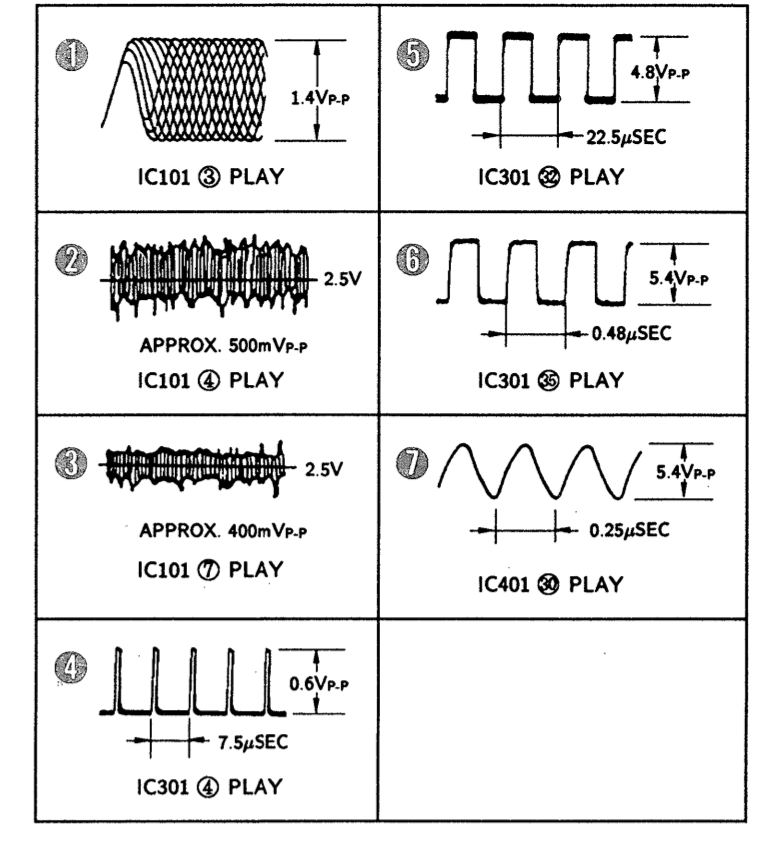

FLD401

	8G	7G	6G	5G	4G	3G	2G	1G
a							1	3
b							2	4
c							6	8
d							7	9
e							11	13
f							12	14
g							16	18
h	▶	PEAK	MIN	STEP	SEC		17	19
i		-	•				15	
j	SHUFFLE	JUST	EDIT		TIME			
k	PROGRAM	A CUE	A					
l	REPEAT	LINK	B		FADE			
m	1	A. SPACE	Q-D					

Note:
 • All capacitors are in μF unless otherwise noted. pF: μμF
 50WV or less are not indicated except for electrolytics and tantalums.
 • All resistors are in Ω and ¼W or less unless otherwise specified.
 Δ: internal component.

Note: The components identified by mark **A** or dotted line with mark **A** are critical for safety. Replace only with part number specified.

- ⊕ : B+ Line
- ⊖ : B- Line
- Voltage and waveforms are do with respect to ground under no-signal (detuned) conditions.
- no mark : STOP
- Voltagess are taken with a VOM (input impedance 10MΩ). Voltage variations may be noted due to normal production tolerances.
- Waveforms are taken with an oscilloscope. Voltage variations may be noted due to normal production tolerances.
- Circled numbers refer to waveforms.
- Signal path.
- ⇒ : CD

IC101 CXD2501

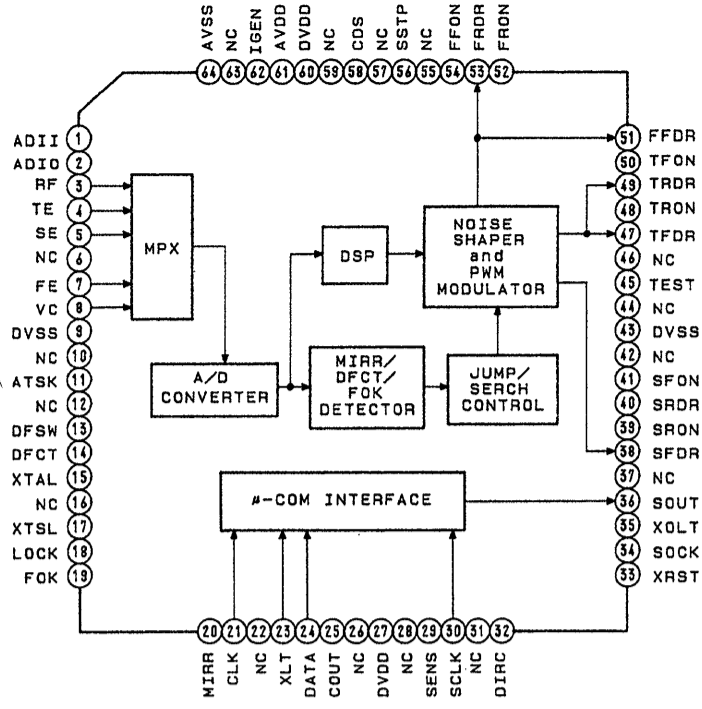

IC301 CXD2500AQ

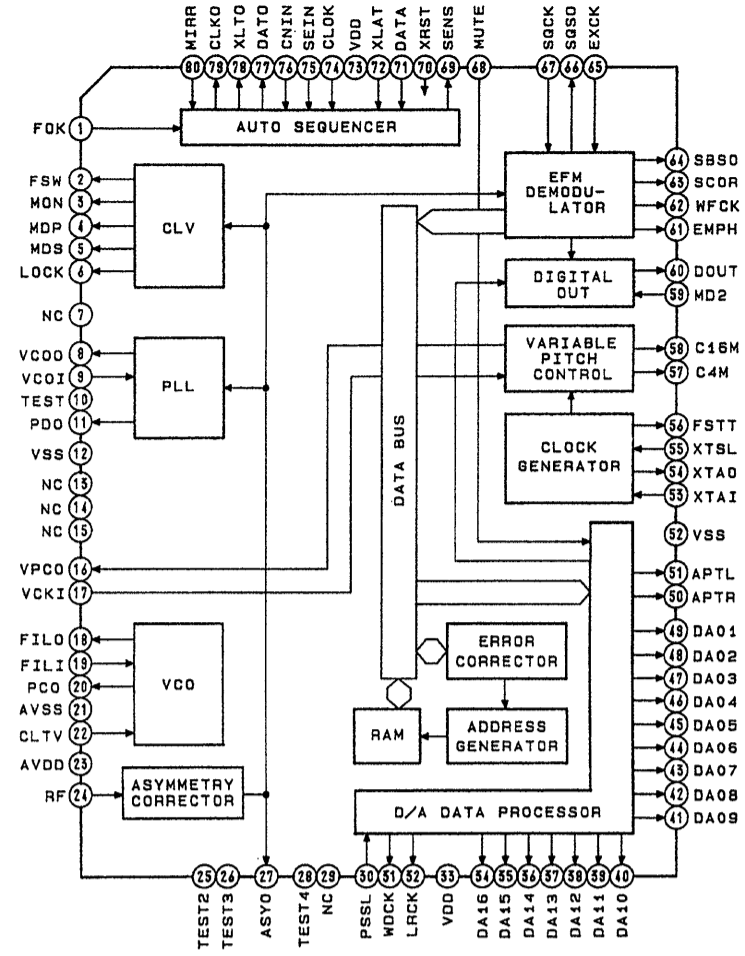

IC103 BA6287F

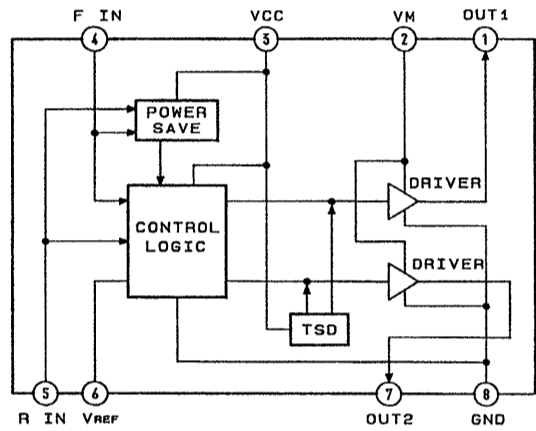

IC302 CXD2560M

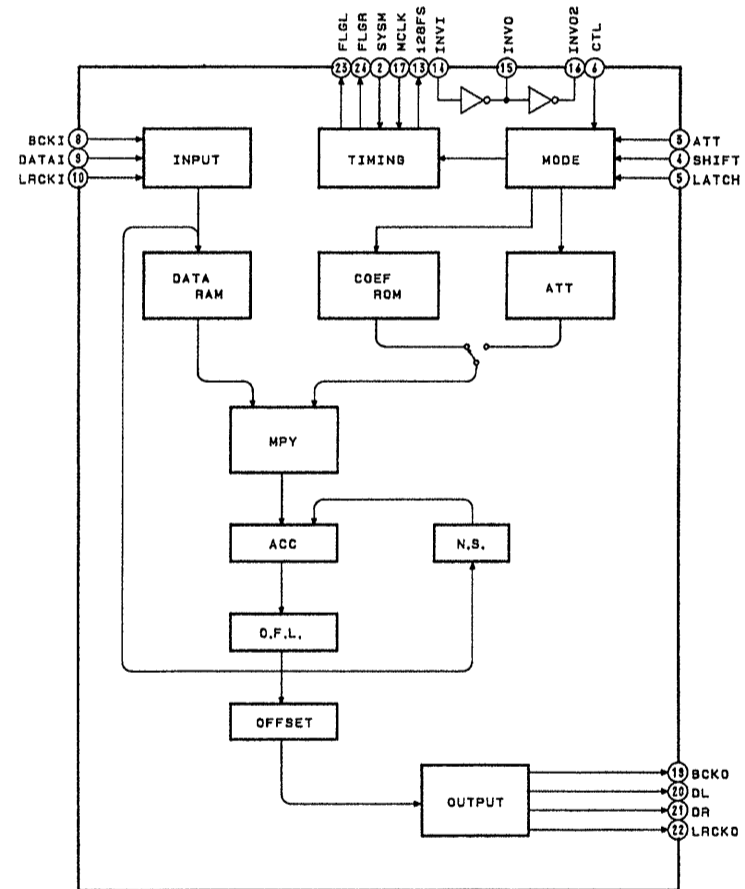

IC201 M5293L

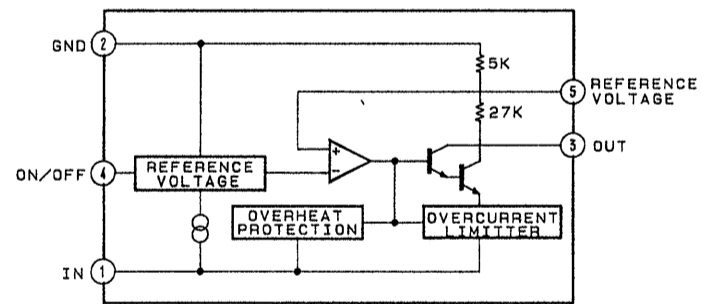

IC202 M5290P-16

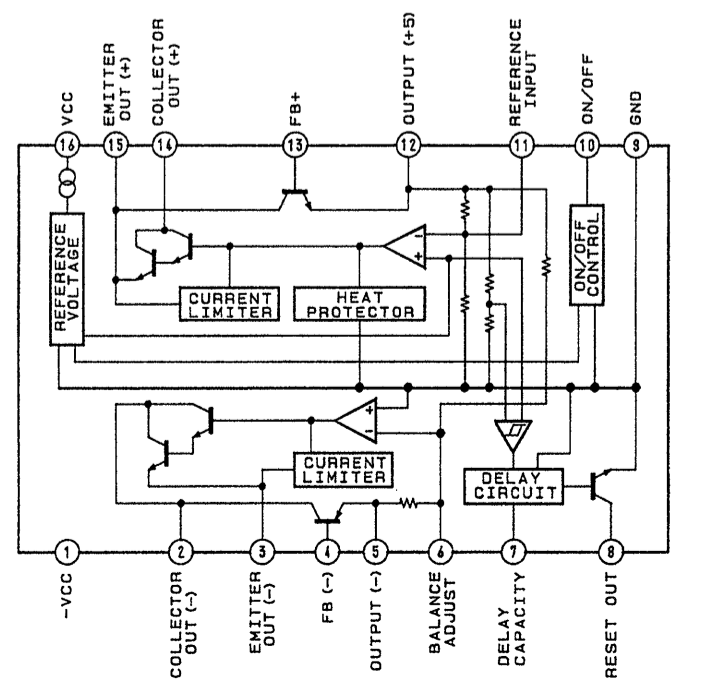

IC303 CXD2561AM

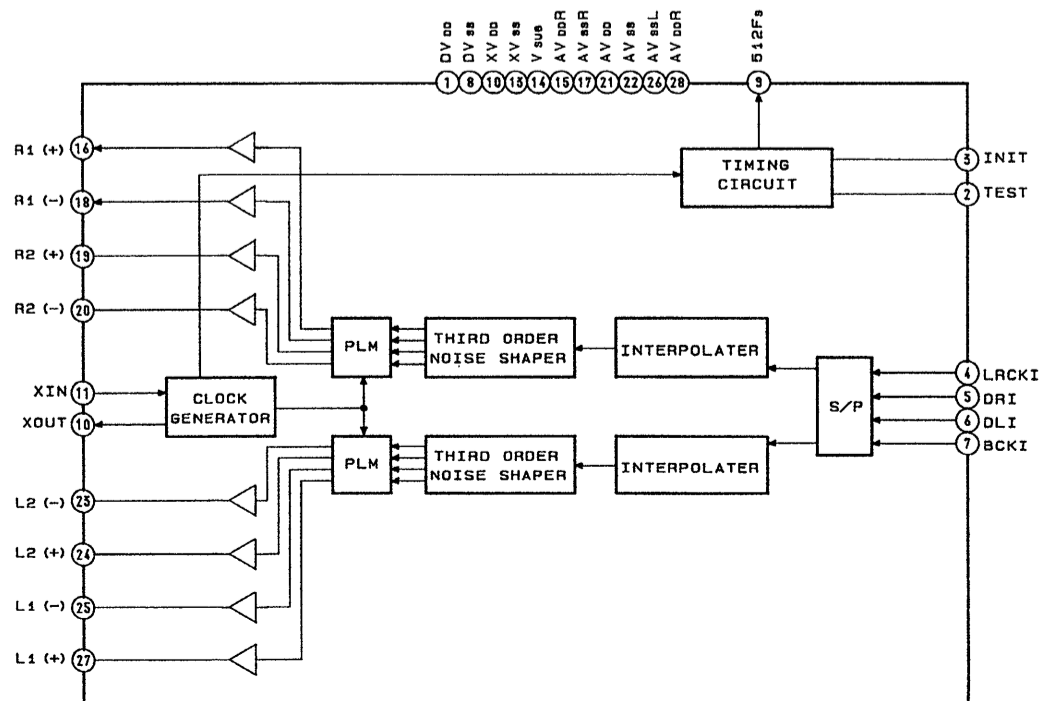

SECTION 5 EXPLODED VIEWS

NOTE:

- -XX, -X mean standardized parts, so they may have some difference from the original one.
- The construction parts of an assembled part are indicated with a collation number in the remark column.
- Color indication of Appearance Parts
Example :
KNOB, BALANCE (WHITE)...(RED)

↑
↑
 Parts color Cabinet's color

- Items marked " * " are not stocked since they are seldom required for routine service. Some delay should be anticipated when ordering these items.
- The mechanical parts with no reference number in the exploded views are not supplied.
- Hardware (# mark) list is given in the last of this parts list.

The components identified by mark or dotted line with mark are critical for safety. Replace only with part number specified.

5-1 CABINET SECTION

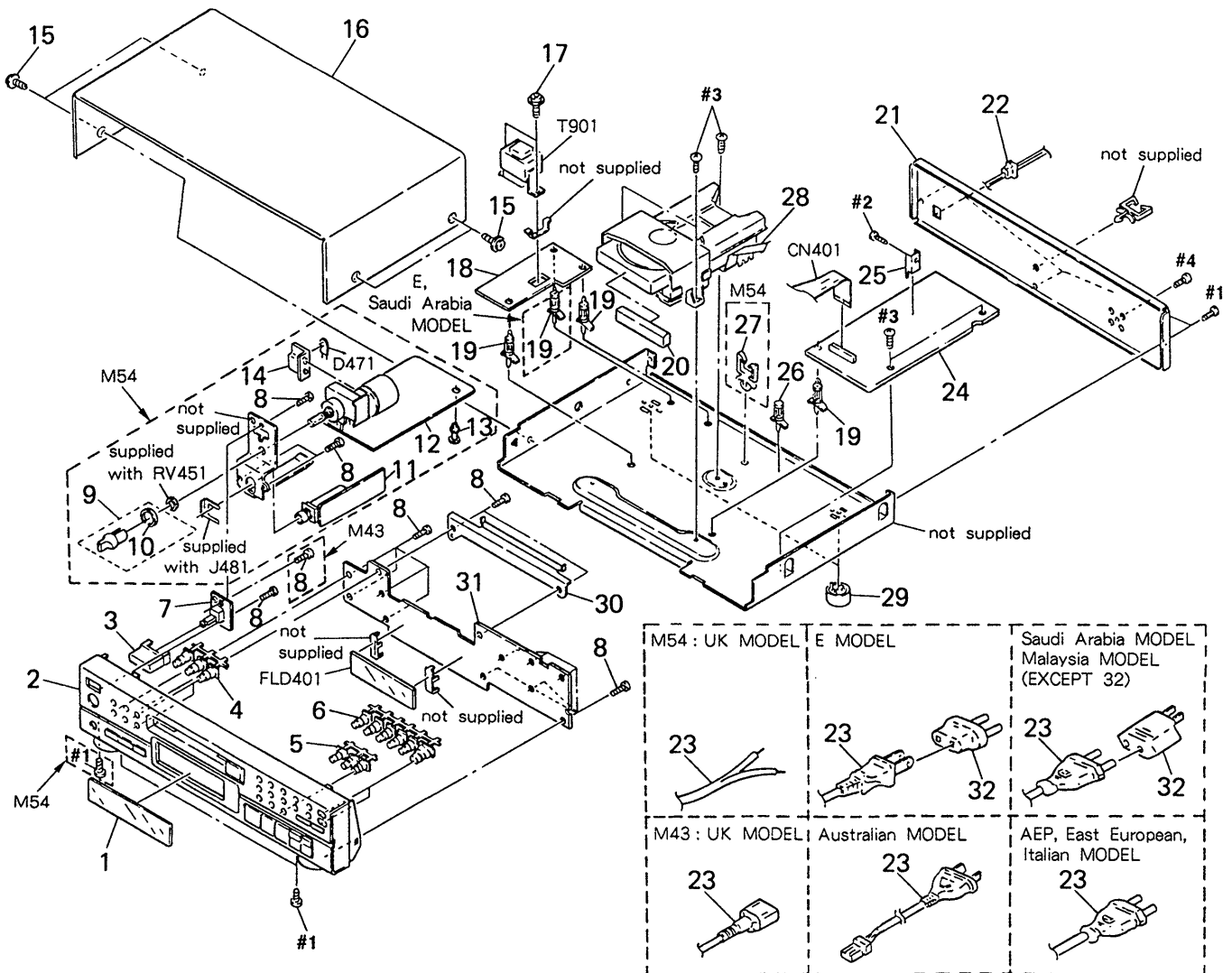

Ref. No.	Part No.	Description	Remark	Ref. No.	Part No.	Description	Remark
1	4-950-182-01	PLATE, INDICATION (M54)		* 21	4-941-467-11	PANEL (ALSACE), BACK (MADE IN FRANCE M43:AEP, East, European, Italian, UK)	
1	4-950-182-11	PLATE, INDICATION (M43)		21	4-941-552-21	PANEL (ALSACE), BACK (MADE IN JAPAN M54:AEP, UK)	
2	X-4942-345-1	PANEL ASSY, FRONT (BLACK) (M54)		* 21	4-949-433-01	PANEL, BACK (MADE IN JAPAN M54:AEP)	
2	X-4942-346-1	PANEL ASSY, FRONT (GRAY) (M43:EXCEPT Italian)		* 21	4-949-433-22	PANEL, BACK (M54:E)	
2	X-4942-347-1	PANEL ASSY, FRONT (BLACK) (M43:Italian)		* 21	4-949-433-41	PANEL, BACK (MADE IN FRANCE M43: AEP, East European)	
3	4-950-176-01	BUTTON (POWER) (GRAY) (M43:EXCEPT Italian)		* 21	4-949-433-51	PANEL, BACK (M43:E, Saudi Arabia, Malaysia)	
3	4-950-176-11	BUTTON (POWER) (BLACK) (M43:Italian, M54)		* 21	4-949-433-61	PANEL, BACK (M43:Australian)	
4	4-950-177-01	BUTTON (G) (GRAY) (M43:EXCEPT Italian)		* 22	3-703-244-00	BUSHING (2104), CORD (EXCEPT E)	
4	4-950-177-11	BUTTON (G) (BLACK) (M43:Italian, M54)		* 22	3-703-571-11	BUSHING (S) (4516), CORD (E)	
5	4-950-179-01	BUTTON (MC/B) (GRAY) (M43:EXCEPT Italian)		△23	1-558-946-21	CORD, POWER (M54:UK)	
5	4-950-179-11	BUTTON (MC/B) (BLACK) (M43:Italian, M54)		△23	1-574-358-31	CORD, POWER (WITH CONNECTOR) (Australian)	
6	4-950-178-01	BUTTON (MC/A) (GRAY) (M43:EXCEPT Italian)		△23	1-575-651-21	CORD, POWER (AEP, East European, Italian, Saudi Arabia, Malaysia)	
6	4-950-178-11	BUTTON (MC/A) (BLACK) (M43:Italian, M54)		△23	1-575-653-21	CORD, POWER (E)	
* 7	1-642-887-21	P. SW BOARD		△23	1-590-379-11	CORD, POWER (M43:UK)	
8	4-928-635-01	SCREW, +BV (2.6X8) TAPPING		* 24	A-4649-105-A	MAIN BOARD, COMPLETE (M54)	
9	A-4604-901-A	KNOB (HP) ASSY (M54)		* 24	A-4649-111-A	MAIN BOARD, COMPLETE (M43)	
10	4-948-469-01	SPRING, RING (M54)		* 25	4-941-237-01	HEAT SINK (M54:UK)	
11	1-642-886-21	HP BOARD (M54)		25	4-902-345-01	HEAT SINK (M43, M54:EXCEPT UK)	
* 12	A-4649-107-A	MOTOR VOL BOARD, COMPLETE (M54)		* 26	3-349-025-41	HOLDER, PC BOARD	
* 13	3-676-567-00	SPACER (M54:E, AEP)		* 27	4-314-320-00	HOLDER, WIRE (M54)	
* 14	4-922-980-01	HOLDER (LED) (M54)		28	1-575-160-11	WIRE, FLAT TYPE (22 CORE)	
15	3-363-099-01	SCREW (CASE +3X8 TP2) (MADE IN FRANCE)		29	4-931-169-01	FOOT	
15	3-704-366-01	SCREW (CASE) (M3X8) (MADE IN JAPAN)		30	4-950-180-01	REINFORCEMENT (MD)	
16	4-919-376-31	CASE (BLACK) (M43:Italian, M54)		* 31	A-4649-104-A	DISP BOARD, COMPLETE (M54)	
16	4-919-376-81	CASE (GRAY) (M43:EXCEPT Italian)		* 31	A-4649-110-A	DISP BOARD, COMPLETE (M43)	
17	4-886-821-11	SCREW, S TIGHT, +PTTWH 3X6		△32	1-569-007-11	ADAPTER, CONVERSION 2P (E)	
* 18	1-642-883-21	POWER BOARD		△32	1-569-008-11	ADAPTER, CONVERSION 2P (Saudi Arabia)	
* 19	4-924-098-31	HOLDER, PC BOARD		CN401	1-535-987-11	JAMPER, FILM (WITH TERMINAL)	
20	4-950-174-01	PANEL, LOADING (GRAY) (M43:EXCEPT Italian)		D471	8-719-970-49	DIODE BR4361F (M54)	
20	4-950-174-11	PANEL, LOADING (BLACK) (M54)		△T901	1-449-922-11	TRANSFORMER, POWER (EXCEPT E, Saudi Arabia, Malaysia)	
20	4-950-174-21	PANEL, LOADING (BLACK) (M43:Italian)		△T901	1-449-923-11	TRANSFORMER, POWER (E, Saudi Arabia, Malaysia)	

5-2 MD SECTION (CDM14L-5BD8A)

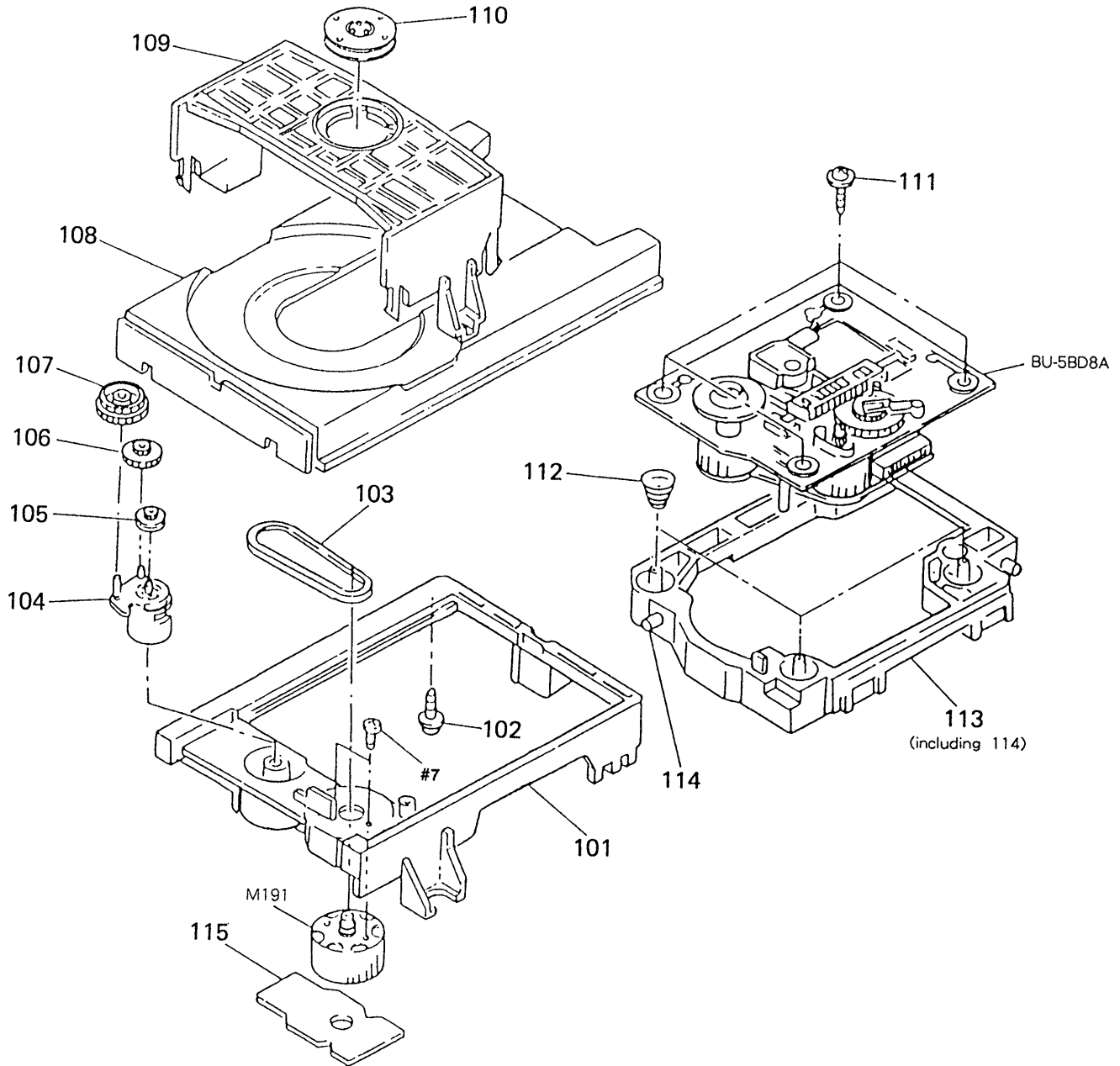

Ref.No.	Part No.	Description	Remark
101	4-933-111-01	CHASSIS (MD) (MADE IN JAPAN)	
101	4-933-111-11	CHASSIS (MD) (MADE IN FRANCE)	
* 102	4-917-583-21	BRACKET, YOKE	
103	4-927-649-01	BELT	
104	4-933-109-01	CAM	
105	4-927-651-01	PULLEY (S)	
106	4-927-628-01	GEAR (C)	
107	4-933-107-01	GEAR (PL)	
108	4-948-894-01	TABLE (ALS), DISK (MADE IN FRANCE)	
108	4-949-336-01	TABLE, DISK (MADE IN JAPAN)	

Ref.No.	Part No.	Description	Remark
109	4-933-110-01	HOLDER (MG)	
* 110	1-452-538-11	MAGNET	
111	4-933-134-01	SCREW (+PTPWH M2.6X6)	
112	4-917-541-01	SPRING (B) (MADE IN FRANCE)	
112	4-948-503-01	SPRING (BU), COMPRESSION (MADE IN JAPAN)	
113	4-933-129-01	HOLDER (BU)	
114	4-933-108-01	SHAFT (CAM)	
* 115	1-632-202-11	LOADING BOARD	
M191	A-4604-363-A	MOTOR (L) ASSY	

5-3 OPTICAL PICK-UP BLOCK (BU-5BD8A)

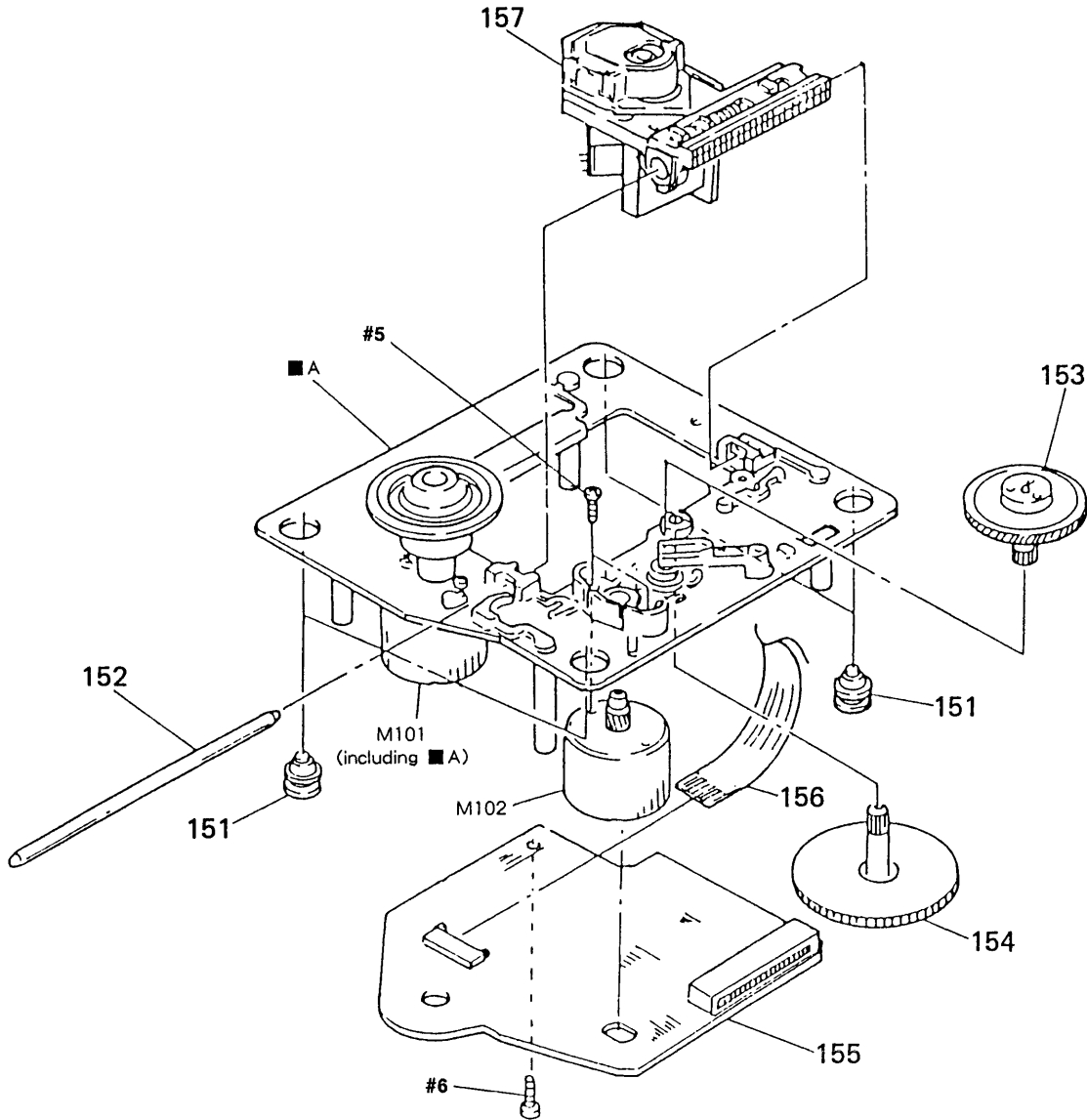

The components identified by mark \triangle or dotted line with mark \triangle are critical for safety. Replace only with part number specified.

Ref. No.	Part No.	Description	Remark	Ref. No.	Part No.	Description	Remark
151	4-933-126-01	INSULATOR (A)		156	1-575-001-11	WIRE, FLAT TYPE (12 CORE)	
152	4-917-565-01	SHAFT, SLED		\triangle 157	8-848-144-11	DEVICE, OPTICAL KSS-240A	
153	4-917-567-01	GEAR (M)		M101	X-4917-523-3	BASE (OUTSERT) ASSY	
154	4-917-564-01	GEAR (P), FLATNESS		M102	X-4917-504-1	MOTOR ASSY	
* 155	A-4617-977-A	BD BOARD, COMPLETE					

BD

SECTION 6 ELECTRICAL PARTS LIST

NOTE :

- Due to standardization, replacements in the parts list may be different from the parts specified in the diagrams or the components used on the set.
- -XX, -X mean standardized parts, so they may have some difference from the original one.
- RESISTORS
All resistors are in ohms
METAL : Metal-film resistor
METAL OXIDE : Metal oxide-film resistor
F : nonflammable

- Items marked " * " are not stocked since they are seldom required for routine service. Some delay should be anticipated when ordering these items.
- SEMICONDUCTORS
In each case, u : μ , for example :
uA.... : μ A...., uPA.... : μ PA....
uPB.... : μ PB...., uPC.... : μ PC....
uPD.... : μ PD....
- CAPACITORS
uF : μ F
- COILS
uH : μ H

The components identified by mark Δ or dotted line with mark Δ are critical for safety. Replace only with part number specified.

When indicating parts by reference number, please include the board.

Ref. No.	Part No.	Description	Remark
*	A-4617-977-A	BD BOARD, COMPLETE *****	
		< CAPACITOR >	
C101	1-163-005-11	CERAMIC CHIP 470PF	10% 50V
C102	1-163-038-00	CERAMIC CHIP 0.1uF	25V
C103	1-163-005-11	CERAMIC CHIP 470PF	10% 50V
C104	1-164-505-11	CERAMIC CHIP 2.2uF	16V
C105	1-135-155-21	TANTALUM CHIP 4.7uF	10% 16V
C106	1-164-346-11	CERAMIC CHIP 1uF	16V
C107	1-164-505-11	CERAMIC CHIP 2.2uF	16V
C108	1-164-346-11	CERAMIC CHIP 1uF	16V
C112	1-163-038-00	CERAMIC CHIP 0.1uF	25V
C151	1-163-007-11	CERAMIC CHIP 680PF	10% 50V
C152	1-163-007-11	CERAMIC CHIP 680PF	10% 50V
C153	1-163-038-00	CERAMIC CHIP 0.1uF	25V
C154	1-164-336-11	CERAMIC CHIP 0.33uF	25V
C155	1-163-007-11	CERAMIC CHIP 680PF	10% 50V
C156	1-163-007-11	CERAMIC CHIP 680PF	10% 50V
C157	1-163-037-11	CERAMIC CHIP 0.022uF	10% 25V
C158	1-163-037-11	CERAMIC CHIP 0.022uF	10% 25V
C159	1-163-023-00	CERAMIC CHIP 0.015uF	5% 50V
C160	1-163-019-00	CERAMIC CHIP 0.0068uF	10% 50V
C181	1-163-038-00	CERAMIC CHIP 0.1uF	25V
		< CONNECTOR >	
CN101	1-568-796-11	SOCKET, CONNECTOR 22P	
CN102	1-568-795-11	SOCKET, CONNECTOR 12P	
CN103	1-564-721-11	PIN, CONNECTOR (SMALL TYPE) 5P	
		< IC >	
IC101	8-752-344-48	IC CXD2501Q	
IC102	8-759-071-80	IC BA6297AFP	
IC103	8-759-040-83	IC BA6287F	

Ref. No.	Part No.	Description	Remark
		< RESISTOR >	
R101	1-216-077-00	METAL CHIP	15K 5% 1/10W
R102	1-216-097-00	METAL CHIP	100K 5% 1/10W
R103	1-216-077-00	METAL CHIP	15K 5% 1/10W
R104	1-216-085-00	METAL CHIP	33K 5% 1/10W
R105	1-216-097-00	METAL CHIP	100K 5% 1/10W
R112	1-216-049-00	METAL CHIP	1K 5% 1/10W
R113	1-216-077-00	METAL CHIP	15K 5% 1/10W
R114	1-216-077-00	METAL CHIP	15K 5% 1/10W
R117	1-216-077-00	METAL CHIP	15K 5% 1/10W
R118	1-216-077-00	METAL CHIP	15K 5% 1/10W
R121	1-216-077-00	METAL CHIP	15K 5% 1/10W
R122	1-216-077-00	METAL CHIP	15K 5% 1/10W
R151	1-216-070-00	METAL CHIP	7.5K 5% 1/10W
R152	1-216-070-00	METAL CHIP	7.5K 5% 1/10W
R153	1-216-070-00	METAL CHIP	7.5K 5% 1/10W
R154	1-216-070-00	METAL CHIP	7.5K 5% 1/10W
R155	1-216-070-00	METAL CHIP	7.5K 5% 1/10W
R156	1-216-070-00	METAL CHIP	7.5K 5% 1/10W
R157	1-216-085-00	METAL CHIP	33K 5% 1/10W
R158	1-216-076-00	METAL CHIP	13K 5% 1/10W
R159	1-216-085-00	METAL CHIP	33K 5% 1/10W
R160	1-216-081-00	METAL CHIP	22K 5% 1/10W
R161	1-216-093-00	METAL CHIP	68K 5% 1/10W
R162	1-216-085-00	METAL CHIP	33K 5% 1/10W
R163	1-216-308-00	METAL CHIP	4.7 5% 1/10W
R181	1-216-021-00	METAL CHIP	68 5% 1/10W
R182	1-216-021-00	METAL CHIP	68 5% 1/10W

BD	DISP	HP
----	------	----

Ref. No.	Part No.	Description	Remark	Ref. No.	Part No.	Description	Remark
		< SWITCH >				< SWITCH >	
S101	1-572-085-11	SWITCH, LEAF (LIMIT SW)		S401	1-554-303-21	SWITCH, TACTILE (CONTINUE)	
*****				S402	1-554-303-21	SWITCH, TACTILE (REPEAT)	
*	A-4649-104-A	DISP BOARD, COMPLETE (M54)		S403	1-554-303-21	SWITCH, TACTILE (II)	
*	A-4649-110-A	DISP BOARD, COMPLETE (M43)		S404	1-554-303-21	SWITCH, TACTILE (D>>)	
*****				S405	1-554-303-21	SWITCH, TACTILE (SHUFFLE)	
		< CAPACITOR >		S406	1-554-303-21	SWITCH, TACTILE (FADER)	
C402	1-164-159-11	CERAMIC 0.1uF	50V	S407	1-554-303-21	SWITCH, TACTILE (▶)	
C403	1-126-154-11	ELECT 47uF	20% 6.3V	S408	1-554-303-21	SWITCH, TACTILE (◀◀◀)	
C404	1-161-494-00	CERAMIC 0.022uF	25V	S409	1-554-303-21	SWITCH, TACTILE (PROGRAM)	
C405	1-164-159-11	CERAMIC 0.1uF	50V	S410	1-554-303-21	SWITCH, TACTILE (TIME)	
		< CONNECTOR >		S411	1-554-303-21	SWITCH, TACTILE (◀◀)	
CN401	1-535-987-11	JAMPER, FILM (WITH TERMINAL)		S412	1-554-303-21	SWITCH, TACTILE (OPEN/CLOSE)	
		< DIODE >		S413	1-554-303-21	SWITCH, TACTILE (■)	
D401	8-719-987-63	DIODE 1N4148M		S414	1-554-303-21	SWITCH, TACTILE (▶▶)	
D402	8-719-987-63	DIODE 1N4148M		S415	1-554-303-21	SWITCH, TACTILE (EDIT)	
D403	8-719-987-63	DIODE 1N4148M		S416	1-554-303-21	SWITCH, TACTILE (TIME SET)	
D404	8-719-987-63	DIODE 1N4148M		S417	1-554-303-21	SWITCH, TACTILE (PEAK SERCH)	
D405	8-719-987-63	DIODE 1N4148M		S418	1-554-303-21	SWITCH, TACTILE (MUSIC SCAN)	
D406	8-719-987-63	DIODE 1N4148M		S419	1-554-303-21	SWITCH, TACTILE (1)	
D407	8-719-987-63	DIODE 1N4148M		S420	1-554-303-21	SWITCH, TACTILE (6)	
D408	8-719-987-63	DIODE 1N4148M		S421	1-554-303-21	SWITCH, TACTILE (11)	
D409	8-719-987-63	DIODE 1N4148M		S423	1-554-303-21	SWITCH, TACTILE (2)	
D410	8-719-987-63	DIODE 1N4148M		S424	1-554-303-21	SWITCH, TACTILE (7)	
D411	8-719-987-63	DIODE 1N4148M		S425	1-554-303-21	SWITCH, TACTILE (12)	
D412	8-719-121-24	DIODE RD9.1ESL		S427	1-554-303-21	SWITCH, TACTILE (3)	
		< FLUORESCENT INDICATOR >		S428	1-554-303-21	SWITCH, TACTILE (8)	
FLD401	1-519-681-11	INDICATOR TUBE, FLUORESCENT		S431	1-554-303-21	SWITCH, TACTILE (4)	
		< IC >		S432	1-554-303-21	SWITCH, TACTILE (9)	
IC401	8-759-061-40	IC uPD75216ACW-C73 (M54)		S435	1-554-303-21	SWITCH, TACTILE (5)	
IC401	8-759-070-44	IC uPD75216ACW-C93 (M43)		S436	1-554-303-21	SWITCH, TACTILE (10)	
IC402	8-741-100-48	IC SBX1610-59 (M54)		S439	1-554-303-21	SWITCH, TACTILE (>12)	
		< RESISTOR >		S440	1-554-303-21	SWITCH, TACTILE (CHECK)	
R401	1-249-435-11	CARBON 33K 5%	1/4W	S441	1-554-303-21	SWITCH, TACTILE (CLEAR)	
R402	1-249-435-11	CARBON 33K 5%	1/4W	S442	1-554-303-21	SWITCH, TACTILE (A. SPACE/A. CUE)	
R403	1-249-435-11	CARBON 33K 5%	1/4W			< VIBRATOR >	
R404	1-249-435-11	CARBON 33K 5%	1/4W	X401	1-577-358-21	VIBRATOR, CERAMIC (4MHz)	
R405	1-249-435-11	CARBON 33K 5%	1/4W	*****			
R406	1-249-425-11	CARBON 4.7K 5%	1/4W			1-642-886-21	HP BOARD (M54)
R407	1-249-425-11	CARBON 4.7K 5%	1/4W			*****	
R408	1-249-439-11	CARBON 68K 5%	1/4W			< CAPACITOR >	
				C481	1-162-294-31	CERAMIC 0.001uF	10% 50V (M54)
				C482	1-162-294-31	CERAMIC 0.001uF	10% 50V (M54)
				C483	1-164-159-11	CERAMIC 0.1uF	50V (M54)

HP **LOADING** **MAIN**

Ref. No.	Part No.	Description	Remark		
< JACK >					
J481	1-568-519-41	JACK, LARGE TYPE (PHONES) (M54)			
< RESISTOR >					
R481	1-249-402-11	CARBON	56	5%	1/4W(M54)
R482	1-249-402-11	CARBON	56	5%	1/4W(M54)

*	1-632-202-11	LOADING BOARD	*****		
< CONNECTOR >					
* CN301	1-564-707-11	PIN, CONNECTOR (SMALL TYPE) 5P			
< SWITCH >					
S271	1-572-086-11	SWITCH, LEAF (OUT SW)			
S272	1-572-086-11	SWITCH, LEAF (IN SW)			

*	A-4649-105-A	MAIN BOARD, COMPLETE (M54)			
*	A-4649-111-A	MAIN BOARD, COMPLETE (M43)	*****		
	4-902-345-01	HEAT SINK (EXCEPT M54:UK)			
*	4-941-237-01	HEAT SINK (M54:UK)			
< CAPACITOR >					
C205	1-126-163-11	ELECT	4.7uF	20%	50V
C206	1-126-059-11	ELECT	10uF	20%	50V
C207	1-126-059-11	ELECT	10uF	20%	50V
C208	1-124-997-11	ELECT	470uF	20%	10V
C209	1-124-997-11	ELECT	470uF	20%	10V
C210	1-126-024-11	ELECT	220uF	20%	16V
C211	1-124-997-11	ELECT	470uF	20%	10V
C212	1-164-159-11	CERAMIC	0.1uF		50V
C213	1-126-012-11	ELECT	470uF	20%	16V
C214	1-126-012-11	ELECT	470uF	20%	16V
C301	1-126-022-11	ELECT	47uF	20%	16V
C302	1-126-301-11	ELECT	1uF	20%	50V
C305	1-126-022-11	ELECT	47uF	20%	16V
C306	1-164-159-11	CERAMIC	0.1uF		50V
C307	1-164-159-11	CERAMIC	0.1uF		50V
C308	1-164-159-11	CERAMIC	0.1uF		50V
C311	1-130-491-00	MYLAR	0.047uF	5%	50V
C312	1-161-374-11	CERAMIC	0.0015uF	20%	50V
C313	1-161-494-00	CERAMIC	0.022uF		25V
C314	1-162-306-11	CERAMIC	0.01uF	20%	16V

Ref. No.	Part No.	Description	Remark		
C315	1-126-300-11	ELECT	0.47uF	20%	50V
C317	1-164-159-11	CERAMIC	0.1uF		50V
C318	1-164-159-11	CERAMIC	0.1uF		50V(M43)
C319	1-162-282-31	CERAMIC	100PF	10%	50V
C320	1-130-483-00	MYLAR	0.01uF	5%	50V
C321	1-162-208-31	CERAMIC	24PF	5%	50V
C322	1-124-994-11	ELECT	100uF	20%	10V
C324	1-164-159-11	CERAMIC	0.1uF		50V
C325	1-162-205-31	CERAMIC	18PF	5%	50V
C326	1-162-205-31	CERAMIC	18PF	5%	50V
C327	1-164-159-11	CERAMIC	0.1uF		50V
C328	1-126-024-11	ELECT	220uF	20%	16V
C329	1-126-024-11	ELECT	220uF	20%	16V
C330	1-162-294-31	CERAMIC	0.001uF	10%	50V
C331	1-164-159-11	CERAMIC	0.1uF		50V
C332	1-164-159-11	CERAMIC	0.1uF		50V
C333	1-164-159-11	CERAMIC	0.1uF		50V
C335	1-164-159-11	CERAMIC	0.1uF		50V
C351	1-126-022-11	ELECT	47uF	20%	16V
C352	1-164-159-11	CERAMIC	0.1uF		50V
C353	1-126-022-11	ELECT	47uF	20%	16V
C354	1-164-159-11	CERAMIC	0.1uF		50V
C355	1-126-022-11	ELECT	47uF	20%	16V
C356	1-164-159-11	CERAMIC	0.1uF		50V
C357	1-124-994-11	ELECT	100uF	20%	10V (M43)
C357	1-124-997-11	ELECT	470uF	20%	10V (M54)
C358	1-124-994-11	ELECT	100uF	20%	10V (M43)
C358	1-124-997-11	ELECT	470uF	20%	10V (M54)
C361	1-162-280-31	CERAMIC	82PF	10%	50V
C362	1-162-280-31	CERAMIC	82PF	10%	50V
C363	1-162-213-31	CERAMIC	39PF	5%	50V
C364	1-162-213-31	CERAMIC	39PF	5%	50V
C365	1-162-213-31	CERAMIC	39PF	5%	50V
C366	1-162-213-31	CERAMIC	39PF	5%	50V
C367	1-161-494-00	CERAMIC	0.022uF		25V
C368	1-161-494-00	CERAMIC	0.022uF		25V
C371	1-106-359-00	MYLAR	4700PF	5%	200V
C372	1-106-359-00	MYLAR	4700PF	5%	200V
C373	1-130-472-00	MYLAR	0.0012uF	5%	50V
C374	1-130-472-00	MYLAR	0.0012uF	5%	50V
C377	1-126-022-11	ELECT	47uF	20%	16V
C378	1-126-022-11	ELECT	47uF	20%	16V
C379	1-106-347-00	MYLAR	1500PF	5%	200V
C380	1-106-347-00	MYLAR	1500PF	5%	200V
C392	1-164-159-11	CERAMIC	0.1uF		50V(M43)
C393	1-164-159-11	CERAMIC	0.1uF		50V(M43)
C394	1-124-994-11	ELECT	100uF	20%	10V(M43)

MAIN

Ref. No.	Part No.	Description	Remark	Ref. No.	Part No.	Description	Remark
< CONNECTOR >							
* CN204	1-564-511-11	PLUG, CONNECTOR 8P		Q372	8-729-141-30	TRANSISTOR 2SC3623A-LK	
* CN301	1-568-843-11	SOCKET, CONNECTOR 28P		Q373	8-729-141-30	TRANSISTOR 2SC3623A-LK	
* CN302	1-568-822-11	SOCKET, CONNECTOR 22P		Q374	8-729-141-30	TRANSISTOR 2SC3623A-LK	
* CN381	1-564-708-11	PIN, CONNECTOR (SMALL TYPE) 6P (M54)		Q375	8-729-231-55	TRANSISTOR 2SC2878-AB	
* CN382	1-564-707-11	PIN, CONNECTOR (SMALL TYPE) 5P (M54)		Q376	8-729-231-55	TRANSISTOR 2SC2878-AB	
* CN391	1-565-561-11	PIN, CONNECTOR 3P (AU BUS) (M43)		Q392	8-729-900-80	TRANSISTOR DTC114ES (M43)	
< DIODE >				< RESISTOR >			
D207	8-719-114-49	DIODE RD7. 5JSB2		R204	1-249-425-11	CARBON 4. 7K 5% 1/4W	
D208	8-719-109-89	DIODE RD5. 6ESB2		R205	1-249-425-11	CARBON 4. 7K 5% 1/4W	
D209	8-719-987-63	DIODE 1N4148M		R206	1-249-417-11	CARBON 1K 5% 1/4W	
D328	8-719-987-63	DIODE 1N4148M		R207	1-249-417-11	CARBON 1K 5% 1/4W	
D344	8-719-987-63	DIODE 1N4148M		R208	1-249-423-11	CARBON 3. 3K 5% 1/4W	
D391	8-719-987-63	DIODE 1N4148M (M43)		R209	1-249-413-11	CARBON 470 5% 1/4W	
< IC >				R210	1-249-429-11	CARBON 10K 5% 1/4W (M54)	
IC202	8-759-630-21	IC M5290P-16		R211	1-249-410-11	CARBON 270 5% 1/4W (M54)	
IC203	8-759-945-58	IC RC4558P (M54)		R214	1-249-417-11	CARBON 1K 5% 1/4W	
IC301	8-752-337-26	IC CXD2500AQ		R301	1-249-417-11	CARBON 1K 5% 1/4W	
IC302	8-752-342-65	IC CXD2560M		R302	1-249-417-11	CARBON 1K 5% 1/4W	
IC303	8-752-349-01	IC CXD2561AM		R303	1-249-421-11	CARBON 2. 2K 5% 1/4W	
IC306	8-759-503-91	IC TL082ACP (M54)		R304	1-249-417-11	CARBON 1K 5% 1/4W	
IC306	8-759-945-58	IC RC4558P (M43)		R306	1-249-413-11	CARBON 470 5% 1/4W	
IC307	8-759-945-58	IC RC4558P		R309	1-249-405-11	CARBON 100 5% 1/4W	
< JACK >				R311	1-249-423-11	CARBON 3. 3K 5% 1/4W	
J381	1-569-442-11	JACK, PIN 2P (LINE OUT) (M43)		R312	1-249-429-11	CARBON 10K 5% 1/4W	
* J381	1-569-443-11	JACK, PIN 4P (LINE OUT) (M54)		R313	1-249-423-11	CARBON 3. 3K 5% 1/4W	
< COIL >				R314	1-249-429-11	CARBON 10K 5% 1/4W	
L301	1-408-403-00	INDUCTOR 3. 3uH		R315	1-249-417-11	CARBON 1K 5% 1/4W	
L321	1-408-403-00	INDUCTOR 3. 3uH		R316	1-249-417-11	CARBON 1K 5% 1/4W	
< TRANSISTOR >				R317	1-249-419-11	CARBON 1. 5K 5% 1/4W	
Q202	8-729-140-96	TRANSISTOR 2SD774-34		R318	1-249-441-11	CARBON 100K 5% 1/4W	
Q203	8-729-141-83	TRANSISTOR 2SB1094-LK		R319	1-247-903-00	CARBON 1M 5% 1/4W	
Q204	8-729-900-65	TRANSISTOR DTA144ES		R320	1-249-417-11	CARBON 1K 5% 1/4W	
Q205	8-729-900-89	TRANSISTOR DTC144ES		R321	1-249-417-11	CARBON 1K 5% 1/4W	
Q206	8-729-900-89	TRANSISTOR DTC144ES		R322	1-249-417-11	CARBON 1K 5% 1/4W	
Q207	8-729-230-45	TRANSISTOR 2SC2458-YGR		R323	1-249-417-11	CARBON 1K 5% 1/4W	
Q208	8-729-141-83	TRANSISTOR 2SB1094-LK		R324	1-249-417-11	CARBON 1K 5% 1/4W	
Q209	8-729-281-52	TRANSISTOR 2SC1815-Y (M54)		R325	1-249-417-11	CARBON 1K 5% 1/4W	
Q341	8-729-900-65	TRANSISTOR DTA144ES		R326	1-249-417-11	CARBON 1K 5% 1/4W	
Q342	8-729-900-65	TRANSISTOR DTA144ES		R327	1-247-903-00	CARBON 1M 5% 1/4W	
Q343	8-729-900-65	TRANSISTOR DTA144ES		R328	1-247-895-00	CARBON 470K 5% 1/4W	
Q344	8-729-900-89	TRANSISTOR DTC144ES		R330	1-249-417-11	CARBON 1K 5% 1/4W (M43)	
Q371	8-729-141-30	TRANSISTOR 2SC3623A-LK		R343	1-249-441-11	CARBON 100K 5% 1/4W	
				R344	1-249-441-11	CARBON 100K 5% 1/4W	
				R345	1-249-425-11	CARBON 4. 7K 5% 1/4W	
				R346	1-249-425-11	CARBON 4. 7K 5% 1/4W	
				R347	1-249-441-11	CARBON 100K 5% 1/4W	
				R351	1-249-436-11	CARBON 39K 5% 1/4W	

MAIN	MOTOR VOL
-------------	------------------

Ref. No.	Part No.	Description	Remark		
R352	1-249-436-11	CARBON	39K	5%	1/4W
R353	1-249-436-11	CARBON	39K	5%	1/4W
R354	1-249-436-11	CARBON	39K	5%	1/4W
R355	1-249-436-11	CARBON	39K	5%	1/4W
R356	1-249-436-11	CARBON	39K	5%	1/4W
R357	1-249-436-11	CARBON	39K	5%	1/4W
R358	1-249-436-11	CARBON	39K	5%	1/4W
R361	1-249-431-11	CARBON	15K	5%	1/4W (M54)
R361	1-249-432-11	CARBON	18K	5%	1/4W (M43)
R362	1-249-431-11	CARBON	15K	5%	1/4W (M54)
R362	1-249-432-11	CARBON	18K	5%	1/4W (M43)
R363	1-249-431-11	CARBON	15K	5%	1/4W (M54)
R363	1-249-432-11	CARBON	18K	5%	1/4W (M43)
R364	1-249-431-11	CARBON	15K	5%	1/4W (M54)
R364	1-249-432-11	CARBON	18K	5%	1/4W (M43)
R365	1-249-438-11	CARBON	56K	5%	1/4W
R366	1-249-438-11	CARBON	56K	5%	1/4W
R367	1-249-438-11	CARBON	56K	5%	1/4W
R368	1-249-438-11	CARBON	56K	5%	1/4W
R369	1-249-419-11	CARBON	1.5K	5%	1/4W
R370	1-249-419-11	CARBON	1.5K	5%	1/4W
R371	1-249-419-11	CARBON	1.5K	5%	1/4W
R372	1-249-419-11	CARBON	1.5K	5%	1/4W
R373	1-247-887-00	CARBON	220K	5%	1/4W
R374	1-247-887-00	CARBON	220K	5%	1/4W
R375	1-249-409-11	CARBON	220	5%	1/4W
R376	1-249-409-11	CARBON	220	5%	1/4W
R377	1-249-409-11	CARBON	220	5%	1/4W
R378	1-249-409-11	CARBON	220	5%	1/4W
R379	1-249-425-11	CARBON	4.7K	5%	1/4W
R380	1-249-425-11	CARBON	4.7K	5%	1/4W
R381	1-249-425-11	CARBON	4.7K	5%	1/4W
R382	1-249-425-11	CARBON	4.7K	5%	1/4W
R383	1-249-413-11	CARBON	470	5%	1/4W
R384	1-249-413-11	CARBON	470	5%	1/4W
R385	1-249-393-11	CARBON	10	5%	1/4W
R386	1-249-393-11	CARBON	10	5%	1/4W
R388	1-249-393-11	CARBON	10	5%	1/4W (M43)
R389	1-249-413-11	CARBON	470	5%	1/4W (M54)
R390	1-249-413-11	CARBON	470	5%	1/4W (M54)
R395	1-249-429-11	CARBON	10K	5%	1/4W (M43)
R396	1-247-848-11	CARBON	5.1K	5%	1/4W
R397	1-247-848-11	CARBON	5.1K	5%	1/4W
R398	1-247-848-11	CARBON	5.1K	5%	1/4W
R399	1-247-848-11	CARBON	5.1K	5%	1/4W
					< VIBRATOR >
X327	1-579-314-11	VIBRATOR, CRYSTAL (22.5792MHZ)			

*	A-4649-107-A	MOTOR VOL BOARD, COMPLETE (M54)			*****
*	4-922-980-01	HOLDER (LED) (M54)			
					< CAPACITOR >
C451	1-124-443-00	ELECT	100uF	20%	10V(M54)
C452	1-124-443-00	ELECT	100uF	20%	10V(M54)
C471	1-124-443-00	ELECT	100uF	20%	10V(M54)
C472	1-124-768-11	ELECT	4.7uF	20%	50V(M54)
C473	1-164-159-11	CERAMIC	0.1uF		50V(M54)
					< CONNECTOR >
* CN451	1-564-708-11	PIN, CONNECTOR (SMALL TYPE) 6P (M54)			
* CN453	1-564-707-11	PIN, CONNECTOR (SMALL TYPE) 5P (M54)			
CN472	1-506-468-11	CONNECTOR 3P, MALE (M54)			
					< DIODE >
D471	8-719-970-49	DIODE BR4361F (LINE OUT PHONE LEVEL) (M54)			
					< IC >
IC451	8-759-981-89	IC RC4556S (M54)			
IC471	8-759-962-08	IC BA6208 (M54)			
					< RESISTOR >
R451	1-249-435-11	CARBON	33K	5%	1/4W (M54)
R452	1-249-435-11	CARBON	33K	5%	1/4W (M54)
R453	1-249-432-11	CARBON	18K	5%	1/4W (M54)
R454	1-249-432-11	CARBON	18K	5%	1/4W (M54)
R455	1-249-422-11	CARBON	2.7K	5%	1/4W (M54)
R456	1-249-422-11	CARBON	2.7K	5%	1/4W (M54)
R457	1-249-429-11	CARBON	10K	5%	1/4W (M54)
R458	1-249-429-11	CARBON	10K	5%	1/4W (M54)
R461	1-249-399-11	CARBON	33	5%	1/4W (M54)
R462	1-249-399-11	CARBON	33	5%	1/4W (M54)
R471	1-249-411-11	CARBON	330	5%	1/4W (M54)
R472	1-249-417-11	CARBON	1K	5%	1/4W (M54)
R473	1-249-417-11	CARBON	1K	5%	1/4W (M54)
					< VARIABLE RESISTOR >
RV451	1-241-810-11	RES, VAR, CARBON 10K/10K (LINE OUT PHONE LEVEL) (M54)			

P. SW	POWER
-------	-------

Ref.No.	Part No.	Description	Remark
*	1-642-887-21	P. SW BOARD *****	
		< SWITCH >	
S491	1-554-118-00	SWITCH, PUSH (1 KEY)(POWER)	

*	1-642-883-21	POWER BOARD *****	
		< CAPACITOR >	
C201	1-124-572-11	ELECT 100uF	20% 63V
C202	1-126-059-11	ELECT 10uF	20% 50V
C203	1-124-556-11	ELECT 2200uF	20% 16V
C204	1-126-937-11	ELECT 4700uF	20% 16V
C221	1-164-159-11	CERAMIC 0.1uF	50V
		< CONNECTOR >	
* CN201	1-564-511-11	PLUG, CONNECTOR 8P	
* CN203	1-580-230-11	PIN, CONNECTOR (PC BOARD) 3P	
		< DIODE >	
D201	8-719-200-02	DIODE 10E2 (M43:E, Saudi Arabia, Malaysia)	
D201	8-719-200-82	DIODE 11ES2 (M43:EXCEPT E, Saudi Arabia, Malaysia, M54)	
D202	8-719-110-03	DIODE RD7.5ES-B2	
D203	8-719-200-02	DIODE 10E2 (M43:E, Saudi Arabia, Malaysia)	
D203	8-719-200-82	DIODE 11ES2 (M43:EXCEPT E, Saudi Arabia, Malaysia, M54)	
D204	8-719-200-02	DIODE 10E2 (M43:E, Saudi Arabia, Malaysia)	
D204	8-719-200-82	DIODE 11ES2 (M43:EXCEPT E, Saudi Arabia, Malaysia, M54)	
D205	8-719-200-02	DIODE 10E2 (M43:E, Saudi Arabia, Malaysia)	
D205	8-719-200-82	DIODE 11ES2 (M43:EXCEPT E, Saudi Arabia, Malaysia, M54)	
D206	8-719-200-02	DIODE 10E2 (M43:E, Saudi Arabia, Malaysia)	
D206	8-719-200-82	DIODE 11ES2 (M43:EXCEPT E, Saudi Arabia, Malaysia, M54)	
		< IC >	
IC201	8-759-633-42	IC M5293L	

Ref.No.	Part No.	Description	Remark
		< TRANSISTOR >	
Q201	8-729-119-76	TRANSISTOR 2SA1175-HFE	
		< RESISTOR >	
R201	1-249-435-11	CARBON 33K 5% 1/4W	
R202	1-249-438-11	CARBON 56K 5% 1/4W	
R203	1-249-429-11	CARBON 10K 5% 1/4W	
		< SWITCH >	
△S201	1-571-722-11	SWITCH, VOLTAGE SELECTION (E, Saudi Arabia, Malaysia)	

		MISCELLANEOUS *****	
△23	1-558-946-21	CORD, POWER (M54:UK)	
△23	1-574-358-31	CORD, POWER (WITH CONNECTOR) (Australian)	
△23	1-575-651-21	CORD, POWER (AEP, East European, Italian, Saudi Arabia, Malaysia)	
△23	1-575-653-21	CORD, POWER (E)	
△23	1-590-379-11	CORD, POWER (M43:UK)	
28	1-575-160-11	WIRE, FLAT TYPE (22 CORE)	
△32	1-569-007-11	ADAPTER, CONVERSION 2P (E)	
△32	1-569-008-11	ADAPTER, CONVERSION 2P (Saudi Arabia)	
* 110	1-452-538-11	MAGNET	
156	1-575-001-11	WIRE, FLAT TYPE (12 CORE)	
△157	8-848-144-11	DEVICE, OPTICAL KSS-240A	
D471	8-719-970-49	DIODE BR4361F (M54)	
M101	X-4917-523-3	BASE (OUTSERT) ASSY	
M102	X-4917-504-1	MOTOR ASSY	
M191	A-4604-363-A	MOTOR (L) ASSY	
△T901	1-449-922-11	TRANSFORMER, POWER (EXCEPT E, Saudi Arabia, Malaysia)	
△T901	1-449-923-11	TRANSFORMER, POWER (E, Saudi Arabia, Malaysia)	

Ref. No.	Part No.	Description	Remark
ACCESSORIES & PACKING MATERIALS			

	1-465-867-11	REMOTE COMMANDER (RM-D597) (M54)	
	1-558-271-11	CORD, CONNECTION (MADE IN FRANCE)	
	1-559-533-11	CORD, CONNECTION (MADE IN JAPAN)	
	2-181-754-01	COVER, BATTERY (M54)	
	3-754-665-11	MANUAL, INSTRUCTION (English/French Spanish/Portuguese) (M54:AEP, E, UK)	
	3-754-665-41	MANUAL, INSTRUCTION (Dutch/German Italian/Swedish) (M54:AEP)	
*	4-922-998-01	CUSHION (MADE IN JAPAN)	
*	4-927-355-03	CUSHION (MADE IN FRANCE)	
*	4-941-548-01	LABEL, CLASS1	
*	4-948-882-31	INDIVIDUAL CARTON (MADE IN FRANCE M43:AEP, East European, Italian, UK)	
*	4-948-882-41	INDIVIDUAL CARTON (MADE IN FRANCE M54:AEP, UK)	
*	4-949-971-21	INDIVIDUAL CARTON (MADE IN JAPAN M43:AEP, East European, Australian)	
*	4-949-971-41	INDIVIDUAL CARTON (MADE IN JAPAN M54:E, AEP)	
*	4-949-971-61	INDIVIDUAL CARTON (MADE IN JAPAN M43:E, Malaysia)	

HARDWARE LIST

#	17-682-548-09	SCREW +BVT 3X8 (S)
#	27-682-547-09	SCREW +B 3X6
#	37-682-547-04	SCREW +BVT 3X6 (S)
#	47-685-646-79	SCREW +BVT 3X8 TYPE2 N-S
#	57-621-255-15	SCREW +P 2X3
#	67-685-134-19	SCREW +BTP 2.6X8 TYPE2 N-S
#	77-621-775-10	SCREW +B 2.6X4