

# CDP-S27/S107

## SERVICE MANUAL

AEP Model  
UK Model  
E Model

CDP-S27:

US Model  
AEP Model

CDP-S107:

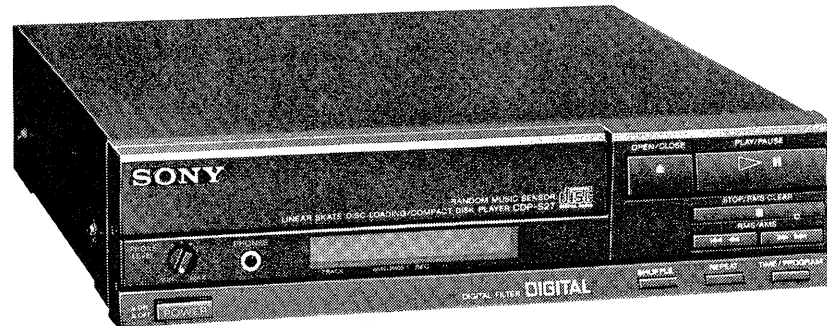

PHOTO: CDP-S27

### SPECIFICATIONS

System	Compact disc digital audio system
Laser	Semiconductor laser ( $\lambda = 780 \text{ nm}$ )
Laser output	Max. $44.6 \mu\text{W}$ This output is the value measured at a distance of about 200 mm from the objective lens surface on the Optical Pick-up Block.
Frequency response	5 Hz – 20kHz ( $-0.5$ / $-2.0$ dB)
Signal to noise ratio	More than 95 dB
Dynamic range	More than 90 dB
Harmonic distortion	Less than 0.05% (at 1 kHz)
Channel separation	More than 90 dB
Wow and flutter	Below measurable limit ( $\pm 0.001\%$ W. PEAK)

	Type	Output level	Load impedance
LINE OUT	Phono jack	2 V (50 kilohms)	more than 10 kilohms
HEAD-PHONES	Stereo minijack	4.5 mW (32 ohms)	—

#### General

	CDP-S27	CDP-S107
Power requirements	US MODEL: 120 V AC, 60 Hz UK MODEL: 240 V AC, 50 Hz AEP MODEL: 220 V AC, 50/60 Hz E MODEL: 110–120 and 220–240 V AC adjustable, 50/60 Hz	
Power consumption	12 W	
Dimensions (Approx.) (w/h/d)	215 × 53 × 228 mm (8 $\frac{1}{2}$ × 2 $\frac{1}{8}$ × 9 inches)	245 × 53 × 228 mm (9 $\frac{5}{8}$ × 2 $\frac{1}{8}$ × 9 inches)
Weight (Approx., net)	2.0 kg (4 lbs 7 oz)	
Supplied accessories	Connecting cord (2 phono plugs ↔ 2 phono plugs) (1) 8 cm CD single adaptor (1)	

COMPACT DISC PLAYER  
**SONY**®





## FEATURES

- Program play for playing the selections in a desired order
- Shuffle play for playing the selections in a random order
- Repeat function for a single selection, the whole disc, program play, or shuffle play
- Easy-to-read display window shows the track number being played, elapsed playing time, and the remaining time

### NOTES ON HANDLING THE OPTICAL PICK-UP BLOCK OR BASE UNIT

The laser diode in the optical pick-up block may suffer electrostatic breakdown because of the potential difference generated by the charged electrostatic load, etc. on clothing and the human body. During repair, pay attention to electrostatic breakdown and also use the procedure in the printed matter which is included in the repair parts. The flexible board is easily damaged and should be handled with care.

#### SAFETY-RELATED COMPONENT WARNING!!

COMPONENTS IDENTIFIED BY MARK  OR DOTTED LINE WITH MARK  ON THE SCHEMATIC DIAGRAMS AND IN THE PARTS LIST ARE CRITICAL TO SAFE OPERATION. REPLACE THESE COMPONENTS WITH SONY PARTS WHOSE PART NUMBERS APPEAR AS SHOWN IN THIS MANUAL OR IN SUPPLEMENTS PUBLISHED BY SONY.

## SAFETY CHECK-OUT

After correcting the original service problem, perform the following safety check before releasing the set to the customer:

Check the antenna terminals, metal trim, "metallized" knobs, screws, and all other exposed metal parts for AC leakage. Check leakage as described below.

### LEAKAGE TEST

The AC leakage from any exposed metal part to earth ground and from all exposed metal parts to any exposed metal part having a return to chassis, must not exceed 0.5 mA (500 microamperes). Leakage current can be measured by any one of three methods.

1. A commercial leakage tester, such as the Simpson 229 or RCA WT-540A. Follow the manufacturers' instructions to use these instruments.
2. A battery-operated AC milliammeter. The Data Precision 245 digital multimeter is suitable for this job.
3. Measuring the voltage drop across a resistor by means of a VOM or battery-operated AC voltmeter. The "limit" indication is 0.75 V, so analog meters must have an accurate low-voltage scale. The Simpson 250 and Sanwa SH-63Trd are examples of a passive VOM that is suitable. Nearly all battery operated digital multimeters that have a 2 V AC range are suitable. (See Fig. A)

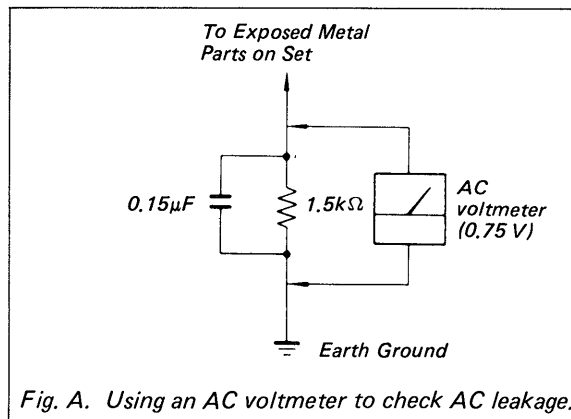

Fig. A. Using an AC voltmeter to check AC leakage.

**TABLE OF CONTENTS**

<u>Section</u>	<u>Title</u>	<u>Page</u>
	Specifications . . . . .	1
	Features . . . . .	2
	Safety Check-out . . . . .	2
	Model Identification . . . . .	3
	Protection of Eyes From Laser Beam During Servicing . . . . .	4
<b>SECTION 1. GENERAL</b>		
1-1.	Location and Function of Controls . . . . .	5
1-2.	Wire Rope Hanging . . . . .	6
<b>SECTION 2. ADJUSTMENTS . . . . . 7-9</b>		
<b>SECTION 3. DIAGRAMS</b>		
3-1.	Printed Wiring Boards . . . . .	10-12
3-2.	Schematic Diagram . . . . .	13-14
<b>SECTION 4. EXPLODED VIEWS . . . . . 15-18</b>		
<b>SECTION 5. ELECTRICAL PARTS LIST . . . . . 19-21</b>		
<b>TROUBLESHOOTING . . . . . 22</b>		

**MODEL IDENTIFICATION**

-Specification Label-

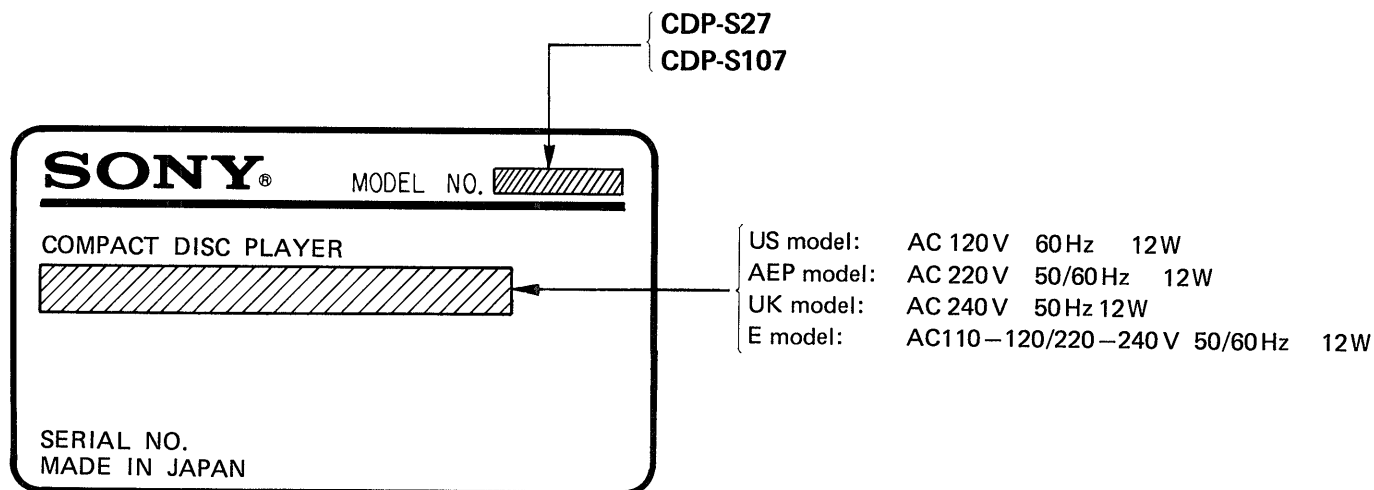

## PROTECTION OF EYES FROM LASER BEAM DURING SERVICING

This set employs a laser. Therefore, be sure to follow carefully the instructions below when servicing.

### CAUTION

Use of controls or adjustments or performance of procedures other than those specified herein may result in hazardous radiation exposure.

### 1. Laser Diode Properties

- Material: GaAlAs
- Wavelength: 780 nm
- Emission Duration: continuous
- Laser Output: max. 44.6  $\mu$ W\*

\* This output is the value measured at a distance of about 200 mm from the objective lens surface on the Optical Pick-up Block.

2. During service, do not take the Optical Pick-up Block apart, and do not adjust the APC circuit. If there is a breakdown in the APC circuit (including laser diode), replace the entire Optical Pick-up Block (including APC board).

---

## BESKYTTELSE AF ØJNE MOD LASERSTRÅLING UNDER SERVICE

I dette apparat anvendes laserlys. Derfor skal nedenstående instruktioner nøje følges under service.

Følg iøvrigt instruktionerne i servicemanualen.

### ADVARSEL!!

Under service må øjnene ikke komme nær objektiv-linsen på den optiske pick-up enhed. I tilfælde af at det er nødvendigt at kontrollere udsendelsen af laserlys, skal det ske i en afstand af mere end 25 cm fra den optiske pick-up.

### 1. Laser-dioe data

- Materiale: GaAlAs
- Bølgelængde: 780 nm
- Udstråling: Kontinuerlig
- Laseroutput: Max. 0,4 mW\*

\* Målt i 1,6 mm afstand fra overfladen af objektiv-linsen på den optiske pick-up enhed.

- Klassifikation: Klasse IIIb.

2. Adskil aldrig den optiske pick-up enhed under service, og juster ikke APC kredsløbet (Automatic Power Control). Hvis APC kredsløbet (incl. laserdioden) bryder ned, skal hele den optiske pick-up enhed (incl. APC printkortet) udskiftes.

## LASER ADVARSEL MÆRKNING

Følgende mærkning findes indvendig i apparatet:

### 1. Advarsel Mærkning

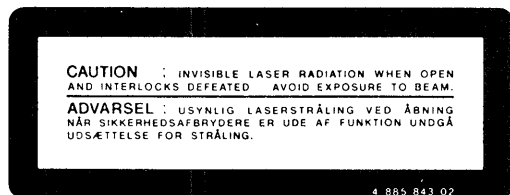

**VAROITUS:** Laite sisältää, laserdiodin, joka lähettää (näkyvätöntä) silmille vaarallista lasersäteilyä.

# SECTION 1 GENERAL

## 1-1. LOCATION AND FUNCTION OF CONTROLS

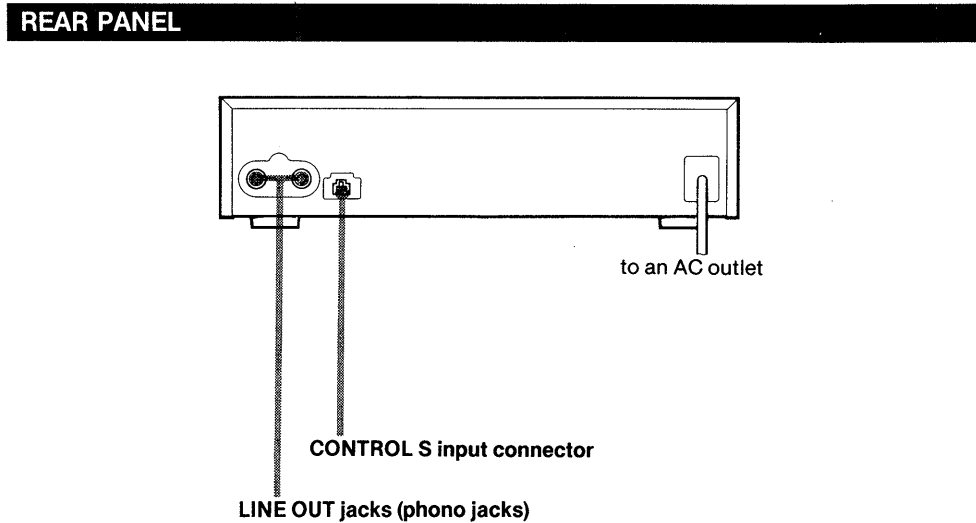
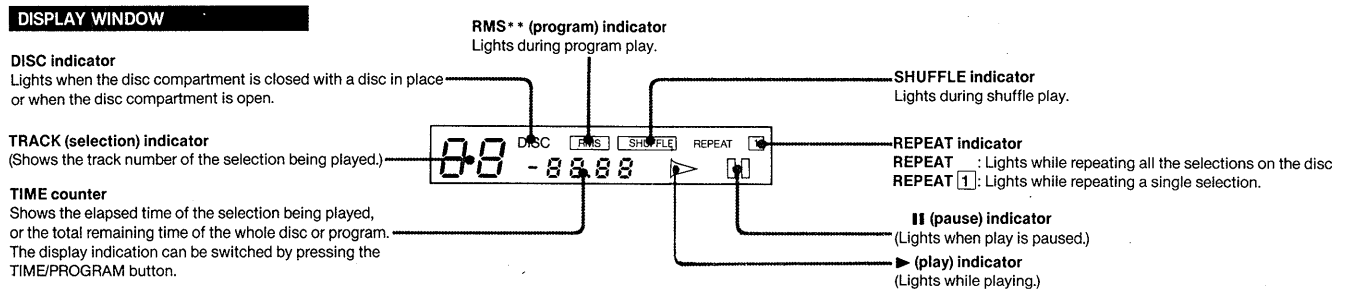
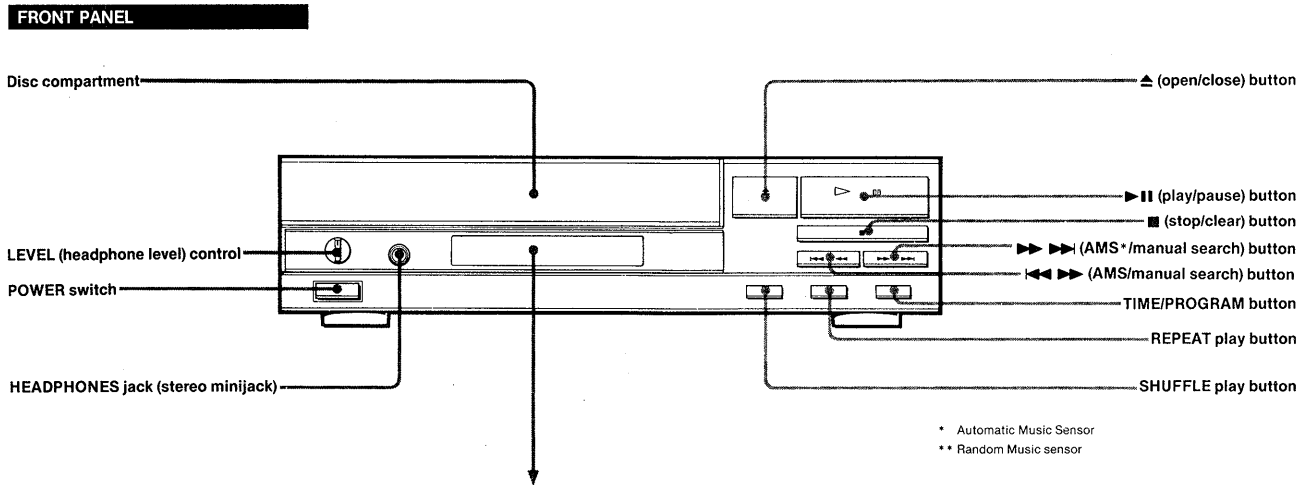

## 1-2. WIRE ROPE HANGING

Proceed from ❶ to ❷

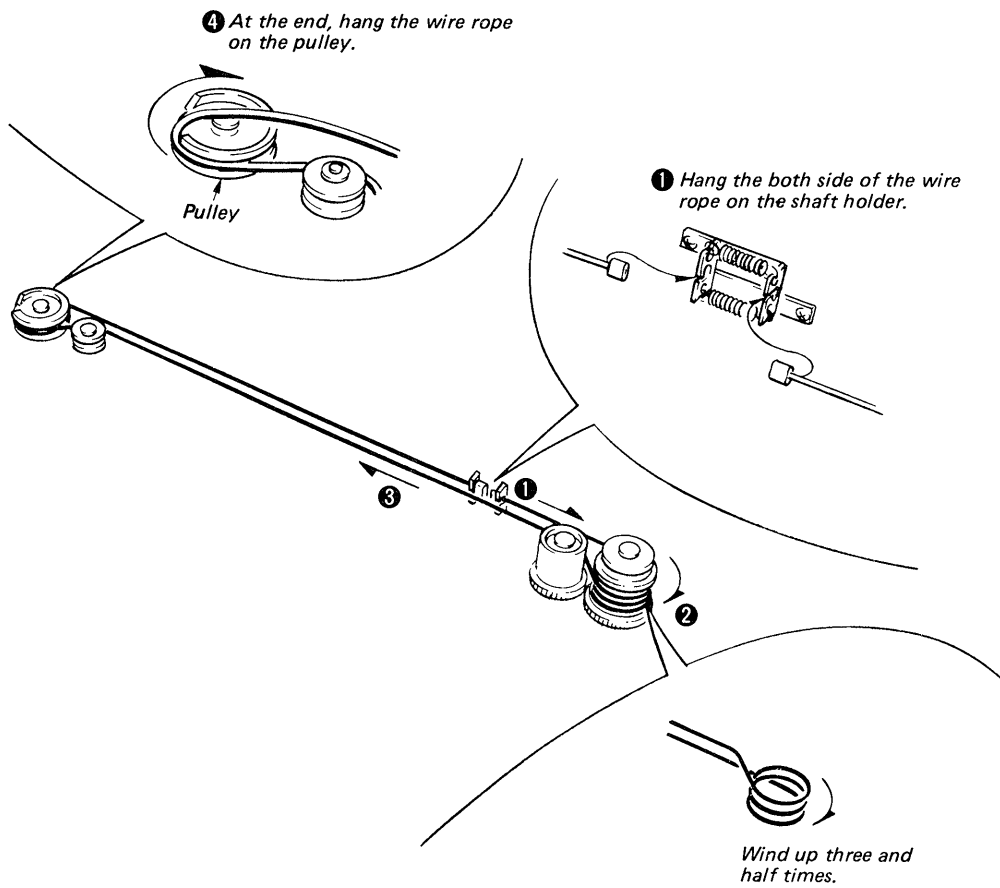

## SECTION 2 ADJUSTMENTS

### ELECTRICAL ADJUSTMENTS

1. Perform adjustments in the order given.
2. Use YEDS-1, YEDS-18 disc unless otherwise indicated.
3. Use the oscilloscope with more than 10MΩ impedance.

#### Adjustment Mode

1. Connect main amp board test point ADJ and GND.

This is to prevent the disc table from opening even though pits are not read, by making microcomputer IC5 pin 19 low.

2. Turn POWER switch on.  
(To reset microcomputer.)
- After adjustment, remove the lead wire connecting test points ADJ and GND.

Adjustment Location: main board

[MAIN BOARD] — Component Side —

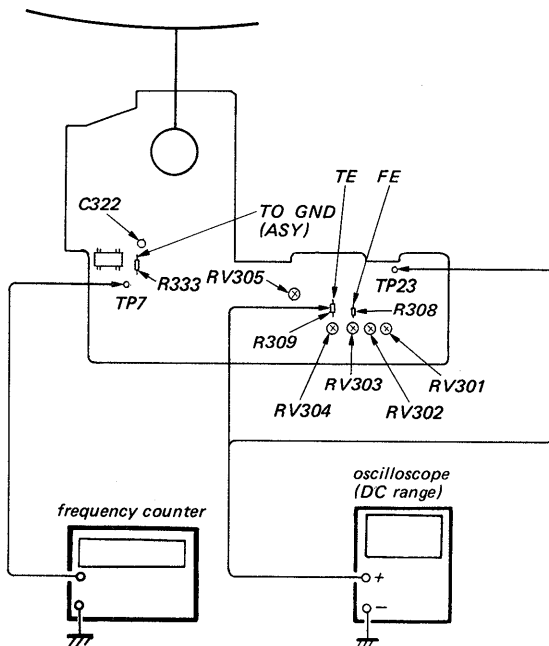
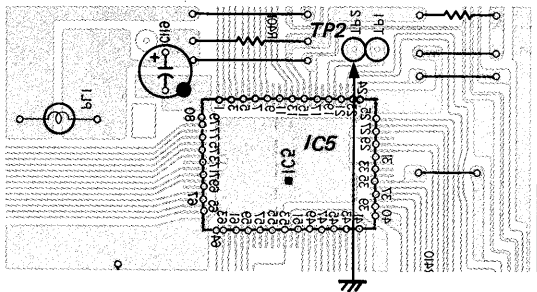

### RF PLL Adjustment

#### Procedure:

1. Turn POWER switch ON (stop mode).
2. Connect main board test point ASY and GND.
3. Connect the frequency counter to main board test points TP PLCK and TP GND.
4. Adjust main board RV305 so that reading on frequency counter is 4.3218 MHz ±30 kHz.
5. Reconnect lead wires connected in adjustment mode.
6. Put disc (YEDS-1) in and press ▷ PLAY button.
7. Confirm that reading on frequency counter is 4.3218 MHz.

### E-F Balance Adjustment

This adjustment should be made when replacing TOP (T-type Optical Pick-up).

#### Procedure:

1. Connect oscilloscope to test point TE.
2. Put set into adjustment mode. (See page 6.)
3. Turn RV304 fully clockwise (minimum).
4. Turn POWER switch on.
5. Put disc (YEDS-1 or YEDS-18) in and press ► ■ button.
6. Adjust RV302 so that the traverse waveform is symmetrical above and below.
7. Set RV304 to its original position.
8. After adjustment, cancel the adjustment mode. (See page 5.)

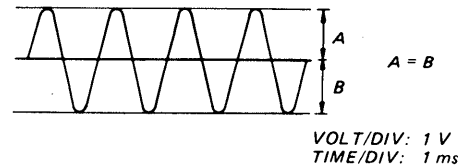

### Focus Bias Adjustment

This adjustment should be made when replacing TOP (T-type Optical Pick-up).

#### Procedure:

1. Connect oscilloscope to test points RF and GND.
2. Turn POWER switch on.
3. Put disc (YSDS-1) in and press ► ■ button.
4. Adjust RV301 for an optimum waveform eye pattern or so that the peak is maximum. Optimum eye pattern means that shape "◇" can be clearly distinguished at the center of the waveform.



REFERENCE

**Focus/Tracking Gain Adjustment**

A frequency response analyzer is necessary in order to perform this adjustment exactly.

However, this gain has a margin, so even if it is slightly off, there is no problem. Therefore, do not perform this adjustment.

Focus/tracking gain determines the pick-up follow-up (vertical and horizontal) relative to mechanical noise and mechanical shock when the 2-axis device operate.

However, as these reciprocate, the adjustment is at the point where both are satisfied.

- When gain is raised, the noise when the 2-axis device operates increases.
- When gain is lowered, it is more susceptible to mechanical shock and skipping occurs more easily.
- When gain adjustment is off, the symptoms below appear.

Symptoms \ Gain	Focus	Tracking
• The time until music starts becomes longer for STOP →▷PLAY or automatic selection (▶) buttons pressed.	low	low or high
• Music does not start and disc continues to rotate for STOP →▷PLAY or automatic selection (▶) buttons pressed.)	—	low
• Disc table opens shortly after STOP →▷PLAY.	low or high	—
• Sound is interrupted during PLAY. Or time counter display stops progressing.	—	low
• More poise during 2-axis device operation.	high	high

6. Connect oscilloscope to main board TP TE.
7. Adjust RV304 so that the waveform is as shown in the figure below. (tracking gain adjustment)

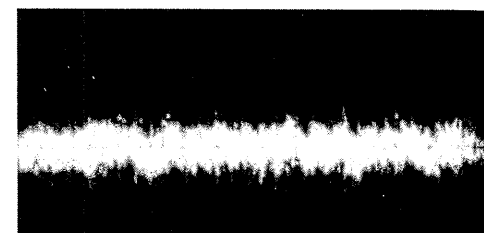

VOLT/DIV: 1 V  
TIME/DIV: 2 mS

- Incorrect Examples (fundamental wave appears)  
*low tracking gain*

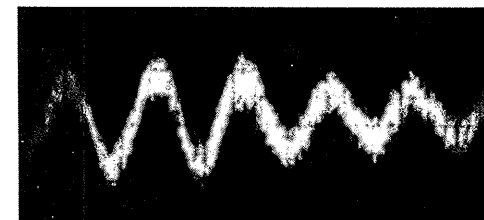

VOLT/DIV: 1 V  
TIME/DIV: 2 mS

- Incorrect Examples (higher fundamental wave than for low gain)  
*high tracking gain*

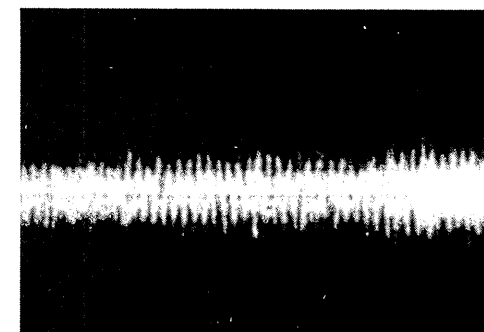

VOLT/DIV: 1 V  
TIME/DIV: 2 mS

- See page 5 for Adjustment Location.

The following is a simple adjustment method.

— Simple Adjustment —

**Note:** Since exact adjustment cannot be performed, remember the positions of the controls before performing the adjustment. If the positions after the simple adjustment are only a little different, return the controls to the original position.

**Procedure:**

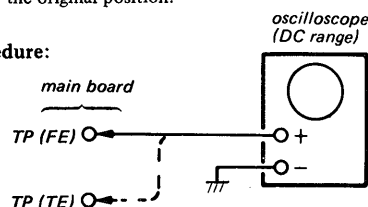

1. Keep the set horizontal.  
(If the set is not horizontal, this adjustment cannot be performed due to the gravity against the 2 axis device.)
2. Put set in adjustment mode. (See page 5.)
3. Insert disc (YEDS-1) and press ▷ PLAY button.
4. Connect oscilloscope to main board TP FE.
5. Adjustment RV303 so that the waveform is as shown in the figure below. (focus gain adjustment)

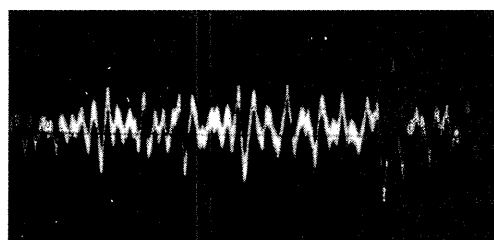

VOLT/DIV: 100 mV  
TIME/DIV: 2 mS

- Inccorrent Examples (DC level changes more than on adjusted waveform)  
*low focus gain*

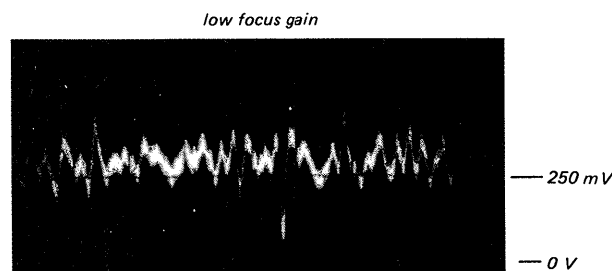

VOLT/DIV: 100 mV  
TIME/DIV: 2 mS

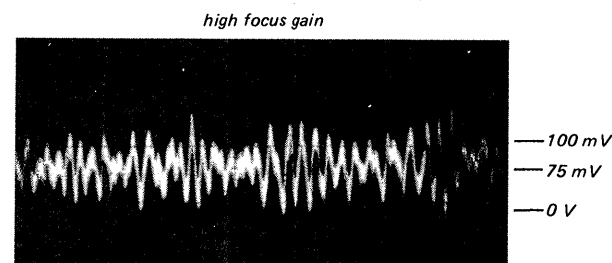

VOLT/DIV: 100 mV  
TIME/DIV: 2 mS

- See page 5 for Adjustment Location.



SEE ADDITIONAL INFORMATION

SEMICONDUCTOR LEAD LAYOUTS

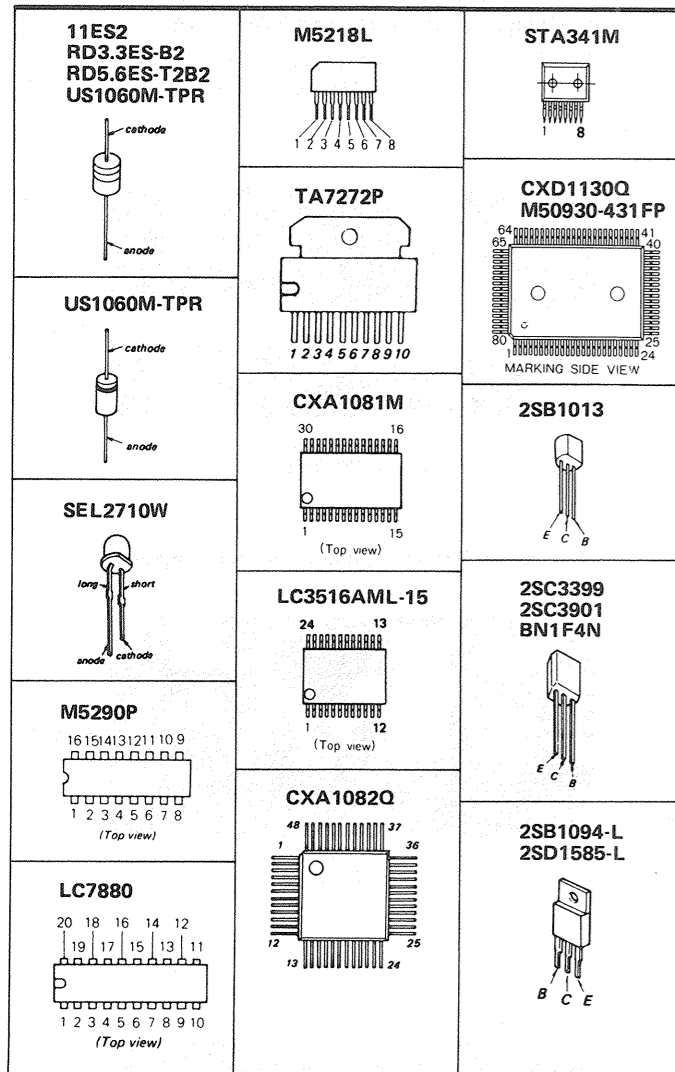

SEMICONDUCTOR LOCATIONS

Ref. No.	Location	Ref. No.	Location
D101	B-3	IC6	F-1
D102	B-3	IC7	E-3
D103	B-3	IC8	B-2
D104	B-3	IC9	H-3
D201	D-1	IC10	I-3
D202	B-1	IC11	H-13
D203	C-1		
D204	D-1	Q1	B-2
D205	B-1	Q2	C-2
D206	E-2	Q3	C-3
D401	B-3	Q4	C-2
D403	B-3	Q5	D-1
		Q6	I-2
IC1	D-3	Q7	H-2
IC2	E-2	Q8	H-1
IC3	G-2	Q9	H-1
IC4	F-2	Q10	B-2
IC5	G-6	Q11	E-3

3-1. PRINTED WIRING BOARDS

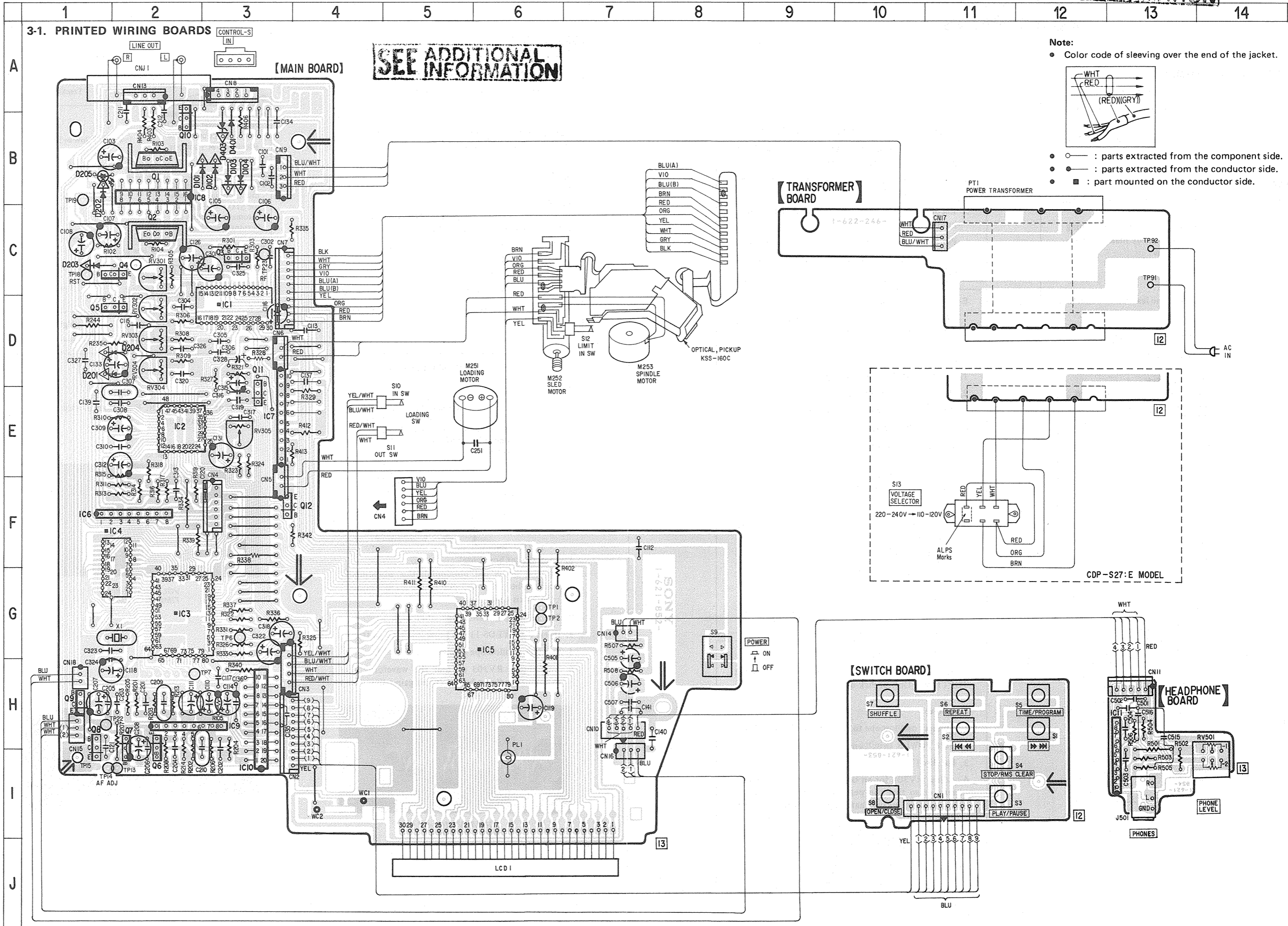

Note: Color code of sleeving over the end of the jacket.

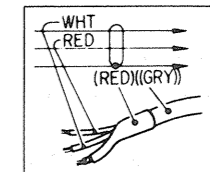

○ : parts extracted from the component side.  
● : parts extracted from the conductor side.  
■ : part mounted on the conductor side.

3-2. SCHEMATIC DIAGRAM

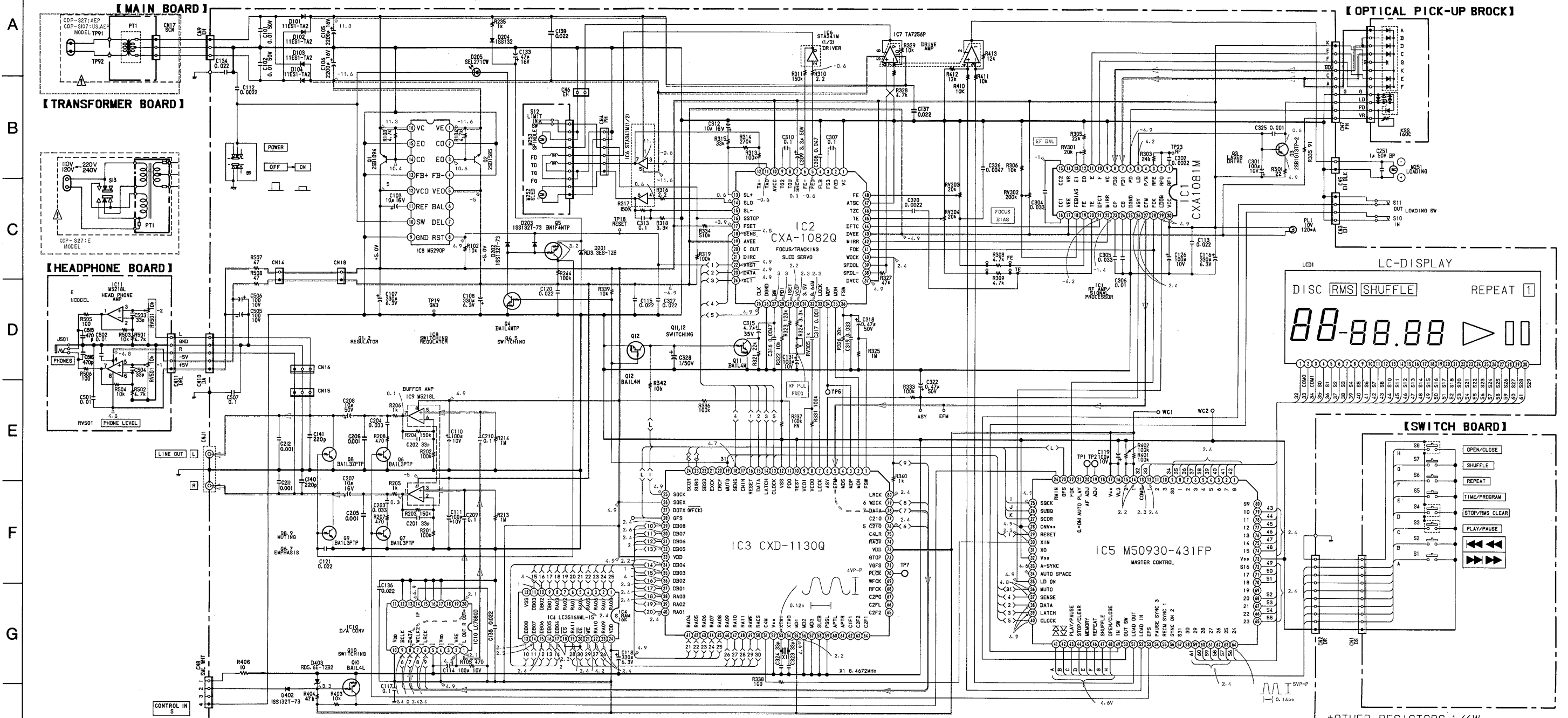

Note:

- All capacitors are in  $\mu\text{F}$  unless otherwise noted. pF:  $\mu\text{mF}$  50WV or less are not indicated except for electrolytics and tantalums.
- All resistors are in  $\Omega$  and  $1/4\text{W}$  or less unless otherwise specified.
- — : L-CH Signal path
- - - - : R-CH Signal path
- — : B+ bus.
- - - - : B- bus.
- □ : adjustment for repair.
- Voltages are dc with respect to ground unless otherwise noted.
- Readings are taken under no-signal (detuned) conditions with a VOM (50  $\text{k}\Omega/\text{V}$ ).
- Voltage variations may be noted due to normal production tolerances.
- Waveforms are taken to ground in PLAY mode by using oscilloscope.

Switches:

Ref. No.	Switch	Position
S1	▶▶▶▶	OFF
S2	◀◀◀◀	OFF
S3	▶▶▶▶	OFF
S4	◀◀◀◀	OFF
S5	▶▶▶▶	OFF
S6	◀◀◀◀	OFF
S7	▶▶▶▶	OFF
S8	◀◀◀◀	OFF
S9	▶▶▶▶	OFF
S10	◀◀◀◀	OFF
S11	▶▶▶▶	OFF
S12	◀◀◀◀	OFF
S13	▶▶▶▶	220-240V

Note: The components identified by mark  $\Delta$  or dotted line with mark  $\Delta$  are critical for safety. Replace only with part number specified.

## SECTION 4 EXPLODED VIEWS

**NOTE:**

- The mechanical parts with no reference number in the exploded views are not supplied.
- The construction parts of an assembled part are indicated with a collation number in the remark column.
- Items marked "★" are not stocked since they are seldom required for routine service. Some delay should be anticipated when ordering these items.

- Due to standardization, parts with part number suffix -XX and -X may be different from the parts specified in the components used on the set.
- Color Indication of Appearance Parts  
Example:  
(RED) ... KNOB, BALANCE (WHITE)  
↑ Cabinet's Color                      ↑ Parts Color

The components identified by mark or dotted line with mark are critical for safety. Replace only with part number specified.

**(1). FRONT PANEL**

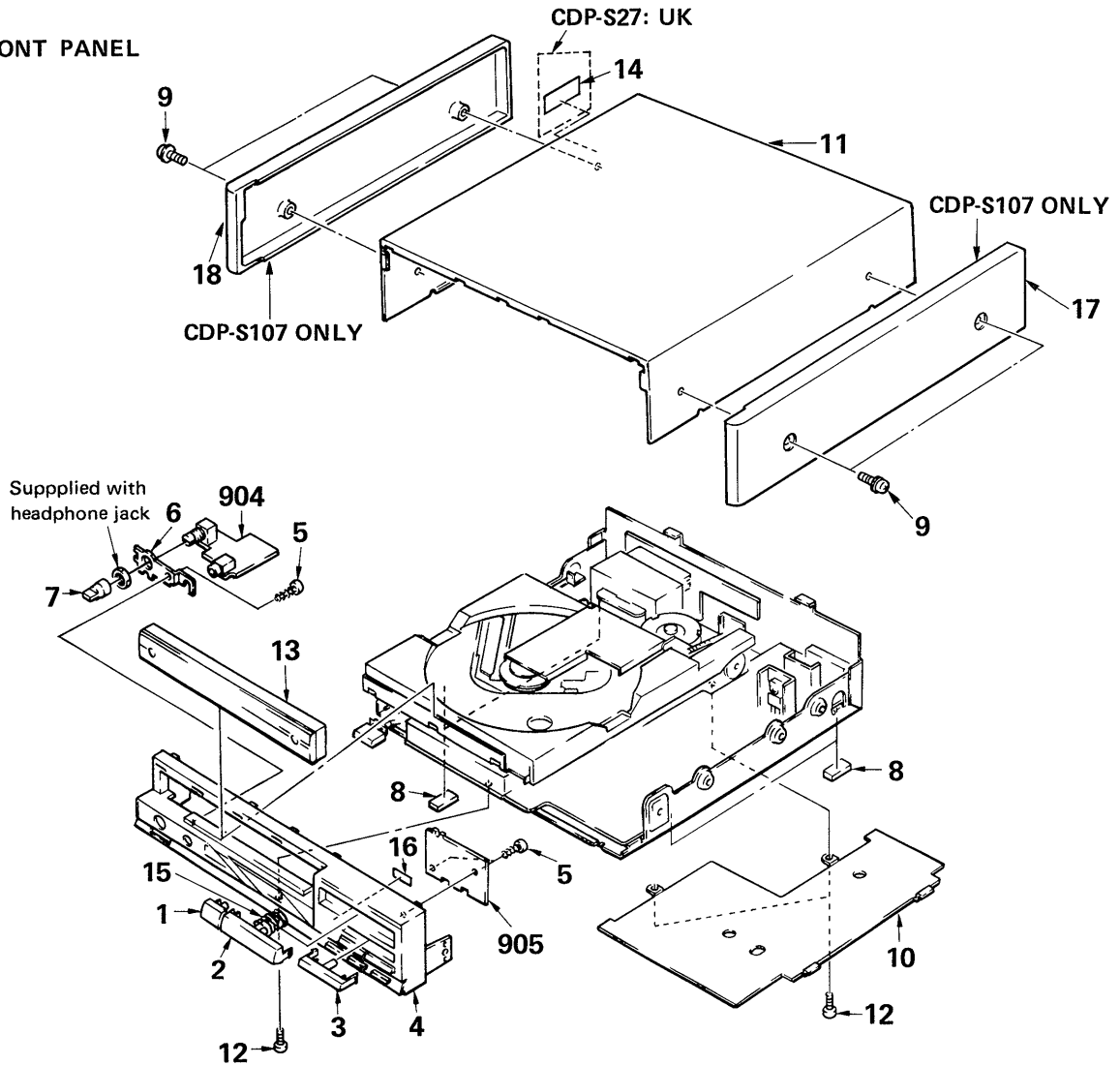

No.	Part No.	Description	Remarks
1	4-920-106-41	(CDP-S27:E) .....BUTTON (GE PRESET)	
	4-920-106-51	(EXCEPT CDP-S27:E) ..BUTTON (GE PRESET)	
2	4-919-838-11	(CDP-S27:E) .....BUTTON (PLAY)	
	4-919-838-21	(EXCEPT CDP-S27:E) ..BUTTON (PLAY)	
3	4-919-839-11	(EXCEPT CDP-S27:E) ..BUTTON (STOP)	
	4-919-839-21	(CDP-S27:E) .....BUTTON (STOP)	
4	X-4919-815-1	(EXCEPT CDP-S27:E) ..PANEL (CD) ASSY, FRONT	
	X-4919-817-1	(CDP-S27:E).....PANEL (CD) ASSY, FRONT	
5	7-685-646-79	SCREW +BVTT 3X8 TYPE 2 N-S	
6	★4-919-827-01	BRACKET (V+H)	
7	4-911-628-11	KNOB, VOLUME	
8	4-919-608-02	FOOT	
9	3-704-366-01	(CDP-S27) ....SCREW, (CASE) (M 3X8)	
	4-886-821-51	(CDP-S107) ...SCREW, (CASE) (M 3X14)	

No.	Part No.	Description	Remarks
10	*4-919-831-01	PLATE, BOTTOM	
11	4-919-842-11	CASE	
12	7-682-147-01	SCREW +BVTT 3X6 (S)	
13	X-4919-814-1	(EXCEPT CDP-S27:E) ..LID ASSY, TRAY	
	X-4919-816-1	(CDP-S27:E) .....LID ASSY, TRAY	
	X-4919-818-1	(CDP-S107) .....LID ASSY, TRAY	
14	3-703-079-21	(UK:CDP-S27) ..LABEL, CAUTION (BACK)	
15	4-919-854-01	SPRING (BUTTON), COMPRESSION	
16	3-849-226-00	CLOTH, UNWEAVED (25X6X0.5)	
17	4-922-759-01	(CDP-S107) ....PLATE (A-RIGHT), SIDE	
	4-922-760-01	(CDP-S107) ....PLATE (A-LIGHT), SIDE	
904	*1-621-854-11	PC BOARD, HEADPHONE	
905	*1-621-853-11	PC BOARD, SWITCH	

(2). CHASSIS

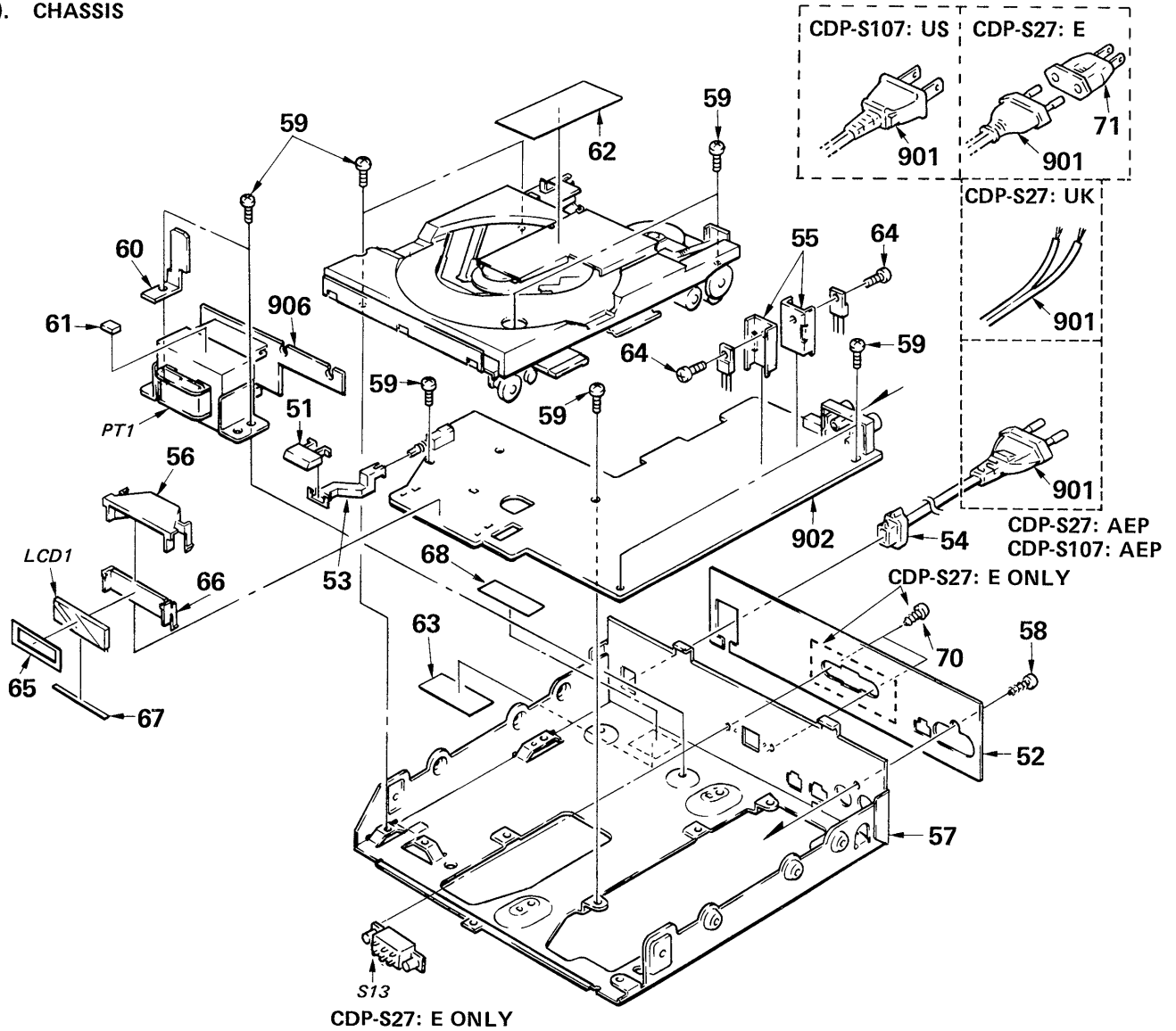

No.	Part No.	Description	Remarks
51	4-914-396-71	BUTTON (POWER)	
52	4-919-801-62	(CDP-S27:E,AEP CDP-S107:AEP) ..COVER, REAR	
	4-919-801-71	(CDP-S27:UK) ..COVER, REAR	
	4-919-801-82	(CDP-S107:AEP) ..COVER, REAR	
	4-919-801-91	(CDP-S107:US) ..COVER, REAR	
53	*4-919-834-01	JOINT	
54	*3-703-244-00	(EXCEPT CDP-S107:US) ..BUSHING (2104), CORD	
	*3-703-571-00	(CDP-S107:US) ..BUSHING (S) (4516), CORD	
55	*3-309-144-21	HEAT SINK	
56	*4-919-832-01	HOUSE, LAMP	
57	*4-919-841-01	CHASSIS (CD)	
58	7-685-646-79	SCREW +BVTP 3X8 TYPE 2 N-S	
59	7-682-147-01	SCREW +BVTT 3X6 (S)	
60	4-919-862-01	SHEET (POWER)	

No.	Part No.	Description	Remarks
61	9-911-840-XX	SPACER (B), RUBBER	
62	4-885-843-02	LABEL, CAUTION, LASER	
63	*4-885-838-01	LABEL, CLASS 1	
64	7-682-548-04	SCREW +BVTT 3X8 (S)	
65	*4-919-844-01	PLATE (C), ORNAMENTAL	
66	*4-919-833-01	ILLUMINATOR	
67	*4-919-843-01	SHEET (LCD)	
68	4-919-856-01	SHEET, INSULATING	
69	4-352-844-01	PIN, LEAD, COATING	
70	7-685-134-19	(CDP-S27:E) ...SCREW +P 2.6X8 TYPE2 NON-SLIT	
71	1-506-409-11	(CDP-S27:E) ...ADAPTOR, CONVERSION	
901	△.1-555-750-00	(CDP-S27:E,AEP CDP-S107:AEP) ..CORD, POWER	
	△.1-556-035-00	(CDP-S27:UK) ..CORD, POWER	
	△.1-558-941-11	(CDP-S107:US) ..CORD, POWER	
		(NONPOLAR, SPT-1)	
902	*A-4651-186-A	MOUNTED PCB, MAIN	
906	*1-622-246-11	PC BOARD, TRANSFORMER	
LCD1	1-807-821-11	DISPLAY PANEL, LIQUID CRYSTAL	
PT1	△.1-448-919-11	(CDP-S27:E) ..TRANSFORMER, POWER	
	△.1-448-920-11	(CDP-S27:AEP,UK CDP-S107:AEP) ..TRANSFORMER, POWER	
	△.1-448-979-11	(CDP-S107:US) ..TRANSFORMER, POWER	
S13	△.1-570-046-21	(CDP-S27:E) ....SWITCH, VOLTAGE CHANGE	

**Note:** The components identified by mark or dotted line with mark are critical for safety. Replace only with part number specified.

SEE ADDITIONAL INFORMATION

(3). DISC TABLE

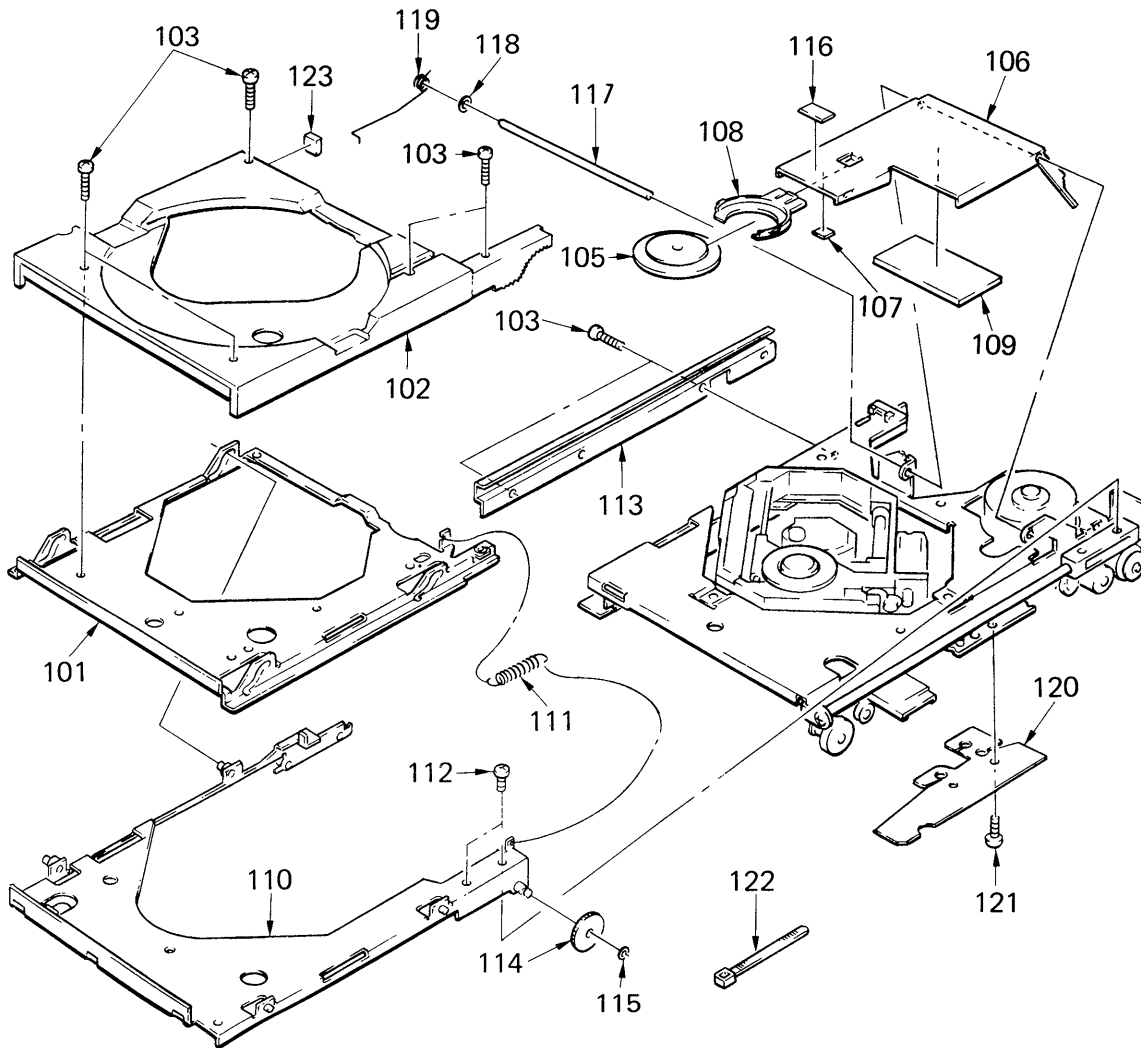

No.	Part No.	Description	Remarks	No.	Part No.	Description	Remarks
101	*4-919-824-01	TABLE, DISC		113	*4-913-254-01	RAIL, GUIDE	
102	4-919-826-01	GUIDE, DISK		114	4-913-214-01	GEAR, S.D	
103	7-627-850-68	SCREW, PRECISION +P 1.4X4		115	3-312-434-00	WASHER, SLIT	
104	X-4919-810-1	LIMITER ASSY		116	9-911-844-XX	CUSHION	
105	X-4919-811-1	PLATE ASSY, CHUCK		118	3-318-236-01	WASHER, POLY, SLIT	
106	4-913-265-01	ARM, CHUCK		117	4-913-222-01	SHAFT, CHUCK ARM	
107	3-327-119-01	SHEET, THRUST		119	4-913-279-01	SPRING	
108	4-913-248-01	GUIDE, CHUCK PLATE		120	*4-919-853-01	STOPPER	
109	9-911-844-XX	SHEET, VIBRATION PROOF		121	7-685-860-01	SCREW +BVTT 2.6X4 (S)	
110	*X-4919-802-1	CHASSIS (MD) ASSY		122	*3-337-402-01	BAND, BINDING	
111	4-919-821-01	SPRING, TENSION		123	9-911-841-XX	CUSHION, RUBBER (R)	
112	3-317-552-61	SCREW (M1.7X2)					

(4). BASE UNIT  
(PICKUP, OPTICAL KSS-160C)

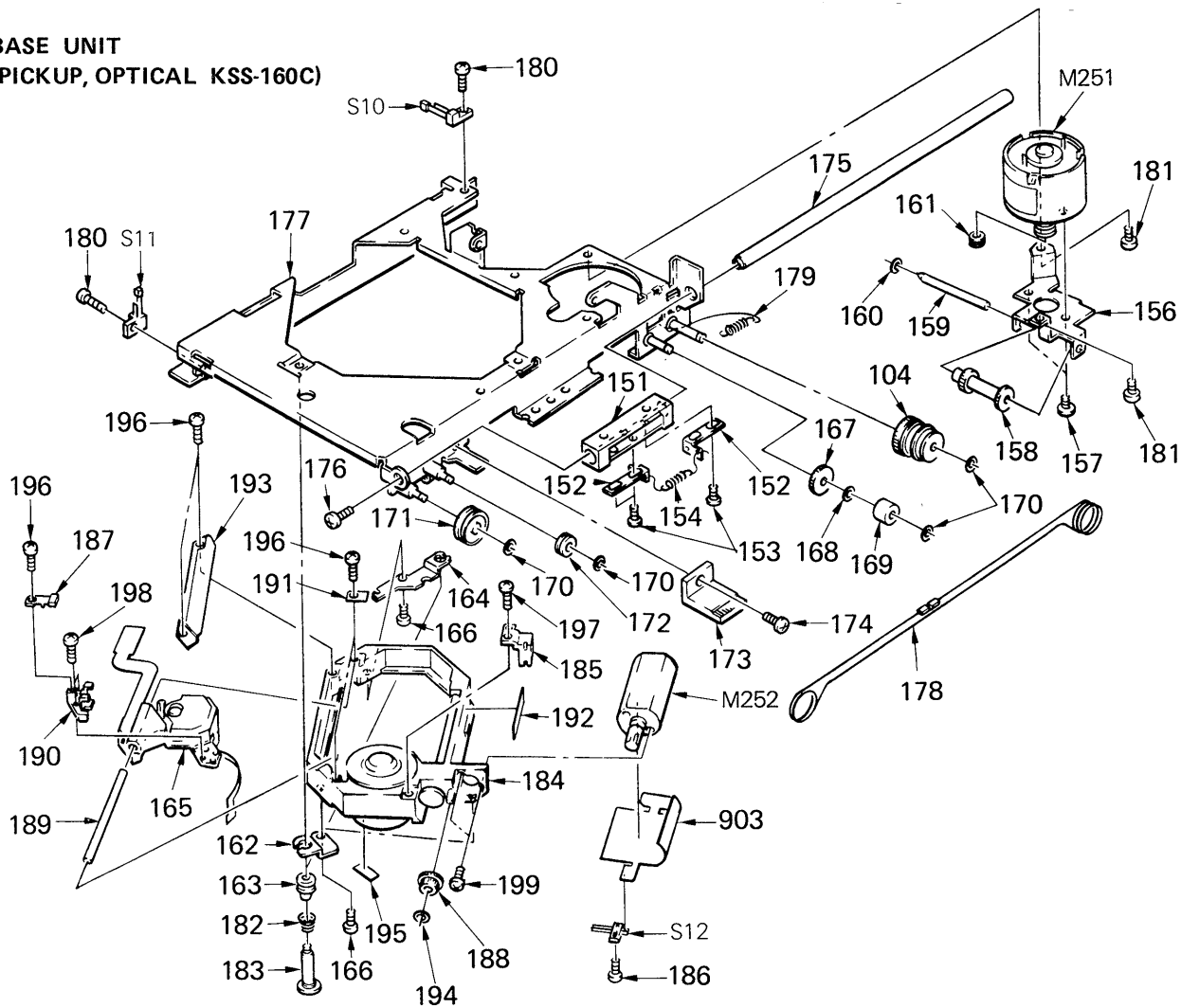

No.	Part No.	Description	Remarks	No.	Part No.	Description	Remarks
151	X-4913-219-1	BEARING ASSY, SLIDE		178	4-913-276-01	ROPE, WIRE	
152	4-913-209-01	SLIDER, WT		179	3-570-556-00	SPRING, TENSION	
153	3-311-772-00	SHAFT (A), STOPPER		180	3-703-502-41	SCREW	
154	3-578-277-00	SPRING, TENSION		181	7-621-259-25	SCREW +BVTT 2.6X4 (S)	
				182	4-919-820-01	SPRING, COMPRESSION	
156	*4-919-803-01	BRACKET (MOTOR)		183	4-919-819-01	SCREW, STEP	
157	4-885-599-00	SCREW, FITTING, REINFORCEMENT		184	X-2640-620-1	SCREW BLOCK ASSY, MD SLED (M253)	
158	4-919-806-01	GEAR (DRIVING)		185	X-2640-611-1	RETAINER ASSY, THRUST	
159	*4-919-809-01	SHAFT (DRIVING)		186	2-640-620-03	SCREW (B) (1.4X3), TAPPING	
160	3-318-236-01	WASHER, POLY, SLIT		187	2-640-622-01	NUT, FEED	
161	2-622-801-01	RETAINER, THRUST		188	2-640-625-01	GEAR (B)	
162	*4-919-804-01	BRACKET (A)		189	2-640-632-01	SHAFT, GUIDE	
163	4-919-818-01	DAMPER		190	2-640-638-01	BEARING, FEED GUIDE	
164	*4-919-805-01	BRACKET (B)		191	2-640-645-01	RETAINER, GUIDE SHAFT	
165	8-848-065-11	PICKUP, OPTICAL KSS-160C		192	*2-640-646-12	LABEL	
166	7-685-102-19	SCREW +P 2X4 TYPE2 NON-SLIT		193	*2-640-647-01	COVER, MD	
167	4-913-212-01	GEAR (B), DRIVING		194	3-321-813-01	WASHER, COTTER POLYETHYLENE	
168	3-701-437-11	WASHER		195	3-831-441-11	CUSHION (B)	
169	4-913-213-01	PULLEY (C)		196	7-685-102-19	SCREW +P 2X4 TYPE2 NON-SLIT	
170	3-312-434-00	WASHER, SLIT		197	7-685-103-19	SCREW +P 2X5 TYPE2 NON-SLIT	
171	4-913-211-01	PULLEY (A)		198	7-627-852-17	+P 1.7X4	
172	3-304-108-00	PULLEY		199	7-627-553-37	PRECISION SCREW +P 2X3 TYPE 3	
173	4-919-822-01	RACK, SD		903	1-621-936-12	PC BOARD, MOT-AU FLEXIBLE	
174	7-627-850-68	SCREW, PRECISION +P 1.4X4		M251	X-4919-809-1	MOTOR ASSY	
175	*4-913-210-01	SHAFT, SLIDE		M252	X-2640-619-1	GEAR ASSY, SLED MOTOR	
176	7-621-255-10	SCREW +B 2X3		S10	1-553-226-00	SWITCH, LEAF	
177	*X-4919-801-1	TABLE ASSY, SLIDE		S11	1-553-226-00	SWITCH, LEAF	
				S12	1-554-938-11	SWITCH, LEAF	

## SECTION 5 ELECTRICAL PARTS LIST

**NOTE:**

- Due to standardization, replacements in the parts list may be different from the parts specified in the diagrams or the components used on the set.
- Items marked "★" are not stocked since they are seldom required for routine service. Some delay should be anticipated when ordering these items.
- If there are two or more same circuits in a set such as a stereophonic machine, only typical circuit parts may be indicated and capacitors and resistors in other same circuits may be omitted.

**CAPACITORS:**

MF:  $\mu$ F, PF:  $\mu$  $\mu$ F.

**RESISTORS**

- All resistors are in ohms.
- F: nonflammable

**COILS**

- MMH: mH, UH:  $\mu$ H

**SEMICONDUCTORS**

In each case, U:  $\mu$ , for example:

UA...:  $\mu$ A..., UPA...:  $\mu$ PA...,  
UPC...:  $\mu$ PC, UPD...:  $\mu$ PD...

The components identified by mark  $\Delta$  or dotted line with mark  $\Delta$  are critical for safety. Replace only with part number specified.

ELECTRICAL PARTS

Ref.No.	Part No.	Description				
901	$\Delta$ .1-555-750-00 $\Delta$ .1-556-035-00 $\Delta$ .1-558-941-11	(CDP-S27:E,AEP CDP-S107:AEP) ..CORD, POWER (CDP-S27:UK) .....CORD, POWER (CDP-S107:US) .....CORD, POWER (NONPOLAR, SPT-1)				
902	*A-4651-186-A	MOUNTED PCB, MAIN				
903	1-621-936-12	PC BOARD, MOT-AU FLEXIBLE				
904	*1-621-854-11	PC BOARD, HEADPHONE				
905	*1-621-853-11	PC BOARD, SWITCH				
906	*1-622-246-11	PC BOARD, TRANSFORMER				
C101	1-136-153-00	FILM	0.01MF	5%	50V	
C102	1-136-153-00	FILM	0.01MF	5%	50V	
C103	1-124-462-00	ELECT	10MF	20%	16V	
C105	1-124-556-11	ELECT	2200MF	20%	16V	
C106	1-124-556-11	ELECT	2200MF	20%	16V	
C107	1-124-442-00	ELECT	330MF	20%	6.3V	
C108	1-124-442-00	ELECT	330MF	20%	6.3V	
C110	1-124-443-00	ELECT	100MF	20%	10V	
C111	1-124-443-00	ELECT	100MF	20%	10V	
C112	1-161-375-00	CERAMIC	0.0022MF	20%	16V	
C113	1-161-494-00	CERAMIC	0.022MF		25V	
C114	1-124-443-00	ELECT	100MF	20%	10V	
C115	1-161-494-00	CERAMIC	0.022MF		25V	
C116	1-124-442-00	ELECT	330MF	20%	6.3V	
C117	1-136-165-00	FILM	0.1MF	5%	50V	
C118	1-124-442-00	ELECT	330MF	20%	6.3V	
C119	1-124-443-00	ELECT	100MF	20%	10V	
C120	1-161-494-00	CERAMIC	0.022MF		25V	
C121	1-161-494-00	CERAMIC	0.022MF		25V	
C126	1-124-443-00	ELECT	100MF	20%	10V	
C131	1-124-443-00	ELECT	100MF	20%	10V	
No. C133	1-124-477-11	ELECT	47MF	20%	16V	
101 C134	1-161-494-00	CERAMIC	0.022MF		25V	
102 C135	1-161-494-00	CERAMIC	0.022MF		25V	
103						
104 C136	1-161-494-00	CERAMIC	0.022MF		25V	
105 C137	1-161-494-00	CERAMIC	0.022MF		25V	
106 C139	1-162-294-31	CERAMIC	0.001MF	10%	50V	
107						
108 C140	1-162-286-31	CERAMIC	220PF	10%	50V	
109 C141	1-162-286-31	CERAMIC	220PF	10%	50V	
110 C142	1-161-494-00	CERAMIC	0.022MF		25V	
111						
112 C201	1-162-211-31	CERAMIC	33PF	5%	50V	
C202	1-162-211-31	CERAMIC	33PF	5%	50V	
C203	1-136-159-00	FILM	0.033MF	5%	50V	
C204	1-136-159-00	FILM	0.033MF	5%	50V	
C205	1-162-294-31	CERAMIC	0.001MF	10%	50V	
C206	1-162-294-31	CERAMIC	0.001MF	10%	50V	
C207	1-124-462-00	ELECT	10MF	20%	16V	
C208	1-124-462-00	ELECT	10MF	5%	16V	
C209	1-136-165-00	FILM	0.1MF	5%	50V	
C210	1-136-165-00	FILM	0.1MF	5%	50V	

ELECTRICAL PARTS

Ref.No.	Part No.	Description				
C211	1-162-294-31	CERAMIC	0.001MF	10%	50V	
C212	1-162-294-31	CERAMIC	0.001MF	10%	50V	
C251	1-124-611-00	CAP,ELECT	1MF		50V	
C301	1-124-443-00	ELECT	100MF	20%	10V	
C302	1-161-375-00	CERAMIC	0.0022MF	20%	16V	
C304	1-136-159-00	FILM	0.033MF	5%	50V	
C305	1-136-159-00	FILM	0.033MF	5%	50V	
C306	1-136-153-00	FILM	0.01MF	5%	50V	
C307	1-136-165-00	FILM	0.1MF	5%	50V	
C308	1-136-161-00	FILM	0.047MF	5%	50V	
C309	1-123-382-00	ELECT	3.3MF	20%	50V	
C310	1-136-165-00	FILM	0.1MF	5%	50V	
C312	1-124-462-00	ELECT	10MF	20%	16V	
C313	1-136-165-00	FILM	0.1MF	5%	50V	
C315	1-124-245-00	ELECT	4.7MF	20%	35V	
C316	1-161-377-00	CERAMIC	0.0047MF	20%	16V	
C317	1-162-294-31	CERAMIC	0.001MF	10%	50V	
C318	1-124-465-00	ELECT	0.47MF	20%	50V	
C319	1-136-159-00	FILM	0.033MF	5%	50V	
C320	1-161-375-00	CERAMIC	0.0022MF	20%	16V	
C322	1-124-465-00	ELECT	0.47MF	20%	50V	
C323	1-162-211-31	CERAMIC	33PF	5%	50V	
C324	1-162-211-31	CERAMIC	33PF	5%	50V	
C325	1-162-294-31	CERAMIC	0.001MF	10%	50V	
C326	1-161-377-00	CERAMIC	0.0047MF	20%	16V	
C327	1-161-494-00	CERAMIC	0.022MF		25V	
C328	1-123-611-00	ELECT	1MF	20%	50V	
C401	1-161-379-00	CERAMIC	0.01MF	20%	16V	
C501	1-161-379-00	CERAMIC	0.01MF	20%	16V	
C502	1-161-379-00	CERAMIC	0.01MF	20%	16V	
C503	1-162-211-31	CERAMIC	33PF	5%	50V	
C504	1-162-211-31	CERAMIC	33PF	5%	50V	
C505	1-124-584-00	ELECT	100MF	20%	10V	
C506	1-124-584-00	ELECT	100MF	20%	10V	
C507	1-136-165-00	FILM	0.1MF	5%	50V	
C515	1-162-290-31	CERAMIC	470PF	10%	50V	
C516	1-162-290-31	CERAMIC	470PF	10%	50V	
CN2	*1-564-666-11	PIN, CONNECTOR 10P				
CN3	*1-564-507-11	PLUG, CONNECTOR 4P				
CN4	*1-564-708-11	PIN, CONNECTOR (SMALL TYPE) 6P				
CN5	*1-564-505-11	PLUG, CONNECTOR 2P				
CN6	*1-564-505-21	PLUG, CONNECTOR 2P				
CN7	*1-564-712-11	PIN, CONNECTOR (SMALL TYPE) 10P				
CN8	1-564-980-11	PIN, CONNECTOR 4P				
CN9	*1-564-506-11	PLUG, CONNECTOR 3P				
CN11	*1-564-498-11	PIN, CONNECTOR 5P				

REVISED

SEE ADDITIONAL  
INFORMATION

## ELECTRICAL PARTS

Ref.No.	Part No.	Description
CNJ1	*1-562-999-41	JACK, PIN 2P
D101	8-719-200-82	DIODE 11ES2
D102	8-719-200-82	DIODE 11ES2
D103	8-719-200-82	DIODE 11ES2
D104	8-719-200-82	DIODE 11ES2
D201	8-719-109-66	DIODE RD3.3ES-B2
D202	8-719-000-26	DIODE US1060M-TPR
D203	8-719-000-26	DIODE US1060M-TPR
D204	8-719-000-26	DIODE US1060M-TPR
D205	8-719-302-94	DIODE SEL2710W
D401	8-719-108-26	DIODE 1SS101
D402	8-719-000-26	DIODE US1060M-TPR
D403	8-719-109-89	DIODE RD5.6ES-T2B2
IC1	8-752-030-93	IC CXA1081M
IC2	8-752-030-94	IC CXA1082Q
IC3	8-752-322-32	IC CXD1130Q
IC4	8-759-802-74	IC LC3516AML-15
IC5	8-759-604-62	IC M50930-431FP
IC6	8-759-303-90	IC STA341M
IC7	8-759-207-05	IC TA7272P
IC8	8-759-604-03	IC M5290P
IC9	8-759-600-02	IC M5218L
IC10	8-759-803-64	IC LC7880
IC11	8-759-600-02	IC M5218L
J501	1-562-917-11	JACK (SMALL TYPE DIA. 3.5)
LC01	1-807-821-11	DISPLAY PANEL, LIQUID CRYSTAL
M251	X-4919-809-1	MOTOR ASSY
M252	X-2640-619-1	SLED MOTOR
M253	X-2640-620-1	SPINDLE MOTOR
PT1	△.1-448-919-11	(CDP-S27:E) ..... TRANSFORMER, POWER
	△.1-448-920-11	(CDP-S27:AEP, UK CDP-S107:AEP).. TRANSFORMER, POWER
	△.1-448-979-11	(CDP-S107:US) ..... TRANSFORMER, POWER
PL1	1-518-623-11	LAMP, PILOT
Q1	8-729-111-67	TRANSISTOR 2SB1094-L
Q2	8-729-107-25	TRANSISTOR 2SD1585-L
Q3	8-729-801-83	TRANSISTOR 2SB1013
Q4	8-729-806-38	TRANSISTOR 2SC3399
Q5	8-729-115-17	TRANSISTOR BN1F4N
Q6	8-729-806-26	TRANSISTOR 2SC3901
Q7	8-729-806-26	TRANSISTOR 2SC3901
Q8	8-729-806-26	TRANSISTOR 2SC3901
Q9	8-729-806-26	TRANSISTOR 2SC3901
Q10	8-729-115-84	TRANSISTOR BA1L4L
Q11	8-729-806-38	TRANSISTOR 2SC3399
Q12	8-729-806-38	TRANSISTOR 2SC3399

## ELECTRICAL PARTS

Ref.No.	Part No.	Description			
R102	1-249-429-11	CARBON	10K	5%	1/4W
R103	1-249-425-11	CARBON	4.7K	5%	1/4W
R104	1-249-425-11	CARBON	4.7K	5%	1/4W
R105	1-249-413-11	CARBON	470	5%	1/4W
R201	1-249-441-11	CARBON	100K	5%	1/4W
R202	1-249-441-11	CARBON	100K	5%	1/4W
R203	1-247-883-00	CARBON	150K	5%	1/4W
R204	1-247-883-00	CARBON	150K	5%	1/4W
R205	1-249-417-11	CARBON	1K	5%	1/4W
R206	1-249-417-11	CARBON	1K	5%	1/4W
R207	1-249-413-11	CARBON	470	5%	1/4W
R208	1-249-413-11	CARBON	470	5%	1/4W
R213	1-215-493-00	CARBON	1M	5%	1/4W
R214	1-215-493-00	CARBON	1M	5%	1/4W
R235	1-249-417-11	CARBON	1K	5%	1/4W
R244	1-249-441-11	CARBON	100K	5%	1/4W
R301	1-214-092-00	METAL	22	1%	1/4W
R303	1-215-454-00	CARBON	24K	5%	1/4W
R305	1-249-433-11	CARBON	22K	5%	1/4W
R306	1-249-429-11	CARBON	10K	5%	1/4W
R308	1-249-425-11	CARBON	4.7K	5%	1/4W
R309	1-249-425-11	CARBON	4.7K	5%	1/4W
R310	1-249-385-11	CARBON	2.2	5%	1/4W
R311	1-247-883-00	CARBON	150K	5%	1/4W
R313	1-249-441-11	CARBON	100K	5%	1/4W
R314	1-215-479-00	CARBON	270K	5%	1/4W
R315	1-249-435-11	CARBON	33K	5%	1/4W
R316	1-249-385-11	CARBON	2.2	5%	1/4W
R317	1-247-883-00	CARBON	150K	5%	1/4W
R318	1-249-423-11	CARBON	3.3K	5%	1/4W
R319	1-249-441-11	CARBON	100K	5%	1/4W
R321	1-249-433-11	CARBON	22K	5%	1/4W
R322	1-249-429-11	CARBON	10K	5%	1/4W
R323	1-247-881-00	CARBON	120K	5%	1/4W
R324	1-249-423-11	CARBON	3.3K	5%	1/4W
R325	1-215-493-00	CARBON	1M	5%	1/4W
R326	1-215-452-00	CARBON	20K	5%	1/4W
R327	1-249-437-11	CARBON	47K	5%	1/4W
R328	1-249-425-11	CARBON	4.7K	5%	1/4W
R329	1-249-429-11	CARBON	10K	5%	1/4W
R331	1-249-441-11	CARBON	100K	5%	1/4W
R333	1-249-441-11	CARBON	100K	5%	1/4W
R334	1-215-486-00	CARBON	510K	5%	1/4W
R335	1-215-396-00	CARBON	91	5%	1/4W
R336	1-215-469-00	METAL	100K	1%	1/6W

**Note:** The components identified by mark  $\Delta$  or dotted line with mark  $\Delta$  are critical for safety. Replace only with part number specified.





ELECTRICAL PARTS

Ref.No.	Part No.	Description			
R337	1-215-469-00	METAL	100K	1%	1/6W
R338	1-249-405-11	CARBON	100	5%	1/4W
R339	1-249-429-11	CARBON	10K	5%	1/4W
R340	1-249-417-11	CARBON	1K	5%	1/4W
R342	1-249-429-11	CARBON	10K	5%	1/4W
R343	1-246-449-25	CARBON	100	5%	1/4W
R401	1-249-441-11	CARBON	100K	5%	1/4W
R402	1-249-441-11	CARBON	100K	5%	1/4W
R403	1-249-429-11	CARBON	10K	5%	1/4W
R404	1-249-437-11	CARBON	47K	5%	1/4W
R405	1-249-405-11	CARBON	100	5%	1/4W
R406	1-249-393-11	CARBON	10	5%	1/4W
R410	1-249-429-11	CARBON	10K	5%	1/4W
R411	1-249-429-11	CARBON	10K	5%	1/4W
R412	1-249-430-11	CARBON	12K	5%	1/4W
R413	1-249-430-11	CARBON	12K	5%	1/4W
R501	1-249-425-11	CARBON	4.7K	5%	1/4W
R502	1-249-425-11	CARBON	4.7K	5%	1/4W
R503	1-249-429-11	CARBON	10K	5%	1/4W
R504	1-249-429-11	CARBON	10K	5%	1/4W
R505	1-249-405-11	CARBON	100	5%	1/4W
R506	1-249-405-11	CARBON	100	5%	1/4W
R507	1-249-401-11	CARBON	47	5%	1/4W
R508	1-249-401-11	CARBON	47	5%	1/4W
RV301	1-237-194-11	RES, ADJ, CARBON 20K			
RV302	1-237-197-11	RES, ADJ, CARBON 200K			
RV303	1-237-194-11	RES, ADJ, CARBON 20K			
RV304	1-237-194-11	RES, ADJ, CARBON 20K			
RV305	1-228-990-00	RES, ADJ, METAL GLAZE 1K			
RV501	1-237-650-11	RES, VAR, CARBON 10K/10K (PHONE LEVEL)			
S1	1-554-303-21	SWITCH, KEY BOARD (▶▶▶▶)			
S2	1-554-303-21	SWITCH, KEY BOARD (◀◀◀◀)			
S3	1-554-303-21	SWITCH, KEY BOARD (PLAY/PAUSE)			
S4	1-554-303-21	SWITCH, KEY BOARD (STOP/RMS/CLEAR)			
S5	1-554-303-21	SWITCH, KEY BOARD (TIME/PROGRAM)			
S6	1-554-303-21	SWITCH, KEY BOARD (REPEAT)			
S7	1-554-303-21	SWITCH, KEY BOARD (SHUFFLE)			
S8	1-554-303-21	SWITCH, KEY BOARD (OPEN/CLOSE)			
S9	1-554-261-00	SWITCH, PUSH (1 KEY)(POWER)			
S10	1-553-226-00	SWITCH, LEAF (IN LOADING)			
S11	1-553-226-00	SWITCH, LEAF (OUT LOADING)			
S12	1-554-938-11	SWITCH, LEAF (LIMIT IN SWITCH)			
S13	△.1-570-046-21	(CDP-S27:E) ...SWITCH, VOLTAGE CHANGE			
X1	1-567-768-21	VIBRATOR, CRYSTAL (8.4672MHZ)			

ACCESSORY & PACKING MATERIAL

Part No.	Description
1-558-543-11	CORD, CONNECTION
2-117-234-01	8 CM SINGLE ADAPTOR
3-701-622-01	BAG, POLYETHYLENE
3-701-625-00	BAG, POLYETHYLENE
3-703-390-01	(CDP-S107:US) ..INSTRUCTION
3-769-907-11	MANUAL, INSTRUCTION
3-769-907-21	(CDP-S107:US) .....MANUAL, INSTRUCTION
3-769-907-41	(CDP-S27:AEP CDP-S107:AEP) ..MANUAL, INSTRUCTION
3-795-629-11	(CDP-S27:AEP CDP-S107:AEP) ..INSTRUCTION
3-849-119-00	BAG, PROTECTION
4-911-686-01	CUSHION (LEFT)
4-911-687-01	CUSHION (RIGHT)
4-919-846-11	(EXCEPT CDP-S107:AEP,US) ...INDIVIDUAL CARTON
4-919-868-00	(CDP-S107:AEP,US) .....INDIVIDUAL CARTON
4-919-867-01	PASTE-BOARD

**Note:** The components identified by mark  or dotted line with mark  are critical for safety. Replace only with part number specified.

## Troubleshooting Guide

The following checks will assist in the correction of most problems which you may encounter with your unit. Should any problem persist after you have made these checks, consult your nearest Sony service facility. Before going through the check list below, first refer back to the connection and operating procedures.

Symptom	Cause	Remedy
Play does not begin.	The disc is incorrectly inserted.	Insert the disc correctly.
	The disc is extremely dirty.	Clean the disc.
	The disc is inserted upside down.	Insert the disc with the label surface up.
	The ►    button has been pressed.	Press the ►    button again to release pause.
	Moisture condensation.	Leave the player turned on for about an hour.
No audio from one or both channels	Incorrect connections	Connect properly.

# CDP-S27/S107

## SONY® SERVICE MANUAL REVISED

*AEP Model*  
*UK Model*  
*E Model*  
*CDP-S27:*  
*US Model*  
*AEP Model*  
*CDP-S107:*

### SUPPLEMENT-1

File this supplement with the service manual.

This supplement updates the following.  
Subject: OPTICAL, PICKUP CHANGE

KSS-160C (former type) → KSS-162A (new type)

#### • ELECTRICAL PARTS LIST

		KSS-160C (former type)	KSS-162A (new type)
MAIN BOARD	CN9 C313	*1-564-506-11 PLUG, CONNECTOR 3P	*1-564-518-11 PLUG, CONNECTOR 3P
		1-136-165-00 FILM 0.1 μF 5% 50V	1-136-159-00 FILM 0.033 μF 5% 50V
CD BOARD	R317	1-247-883-00 CARBON 150K 5% 1/4W	1-247-881-00 CARBON 120K 5% 1/4W

● FORMER TYPE (OPTICAL, PICKUP KSS-160C)

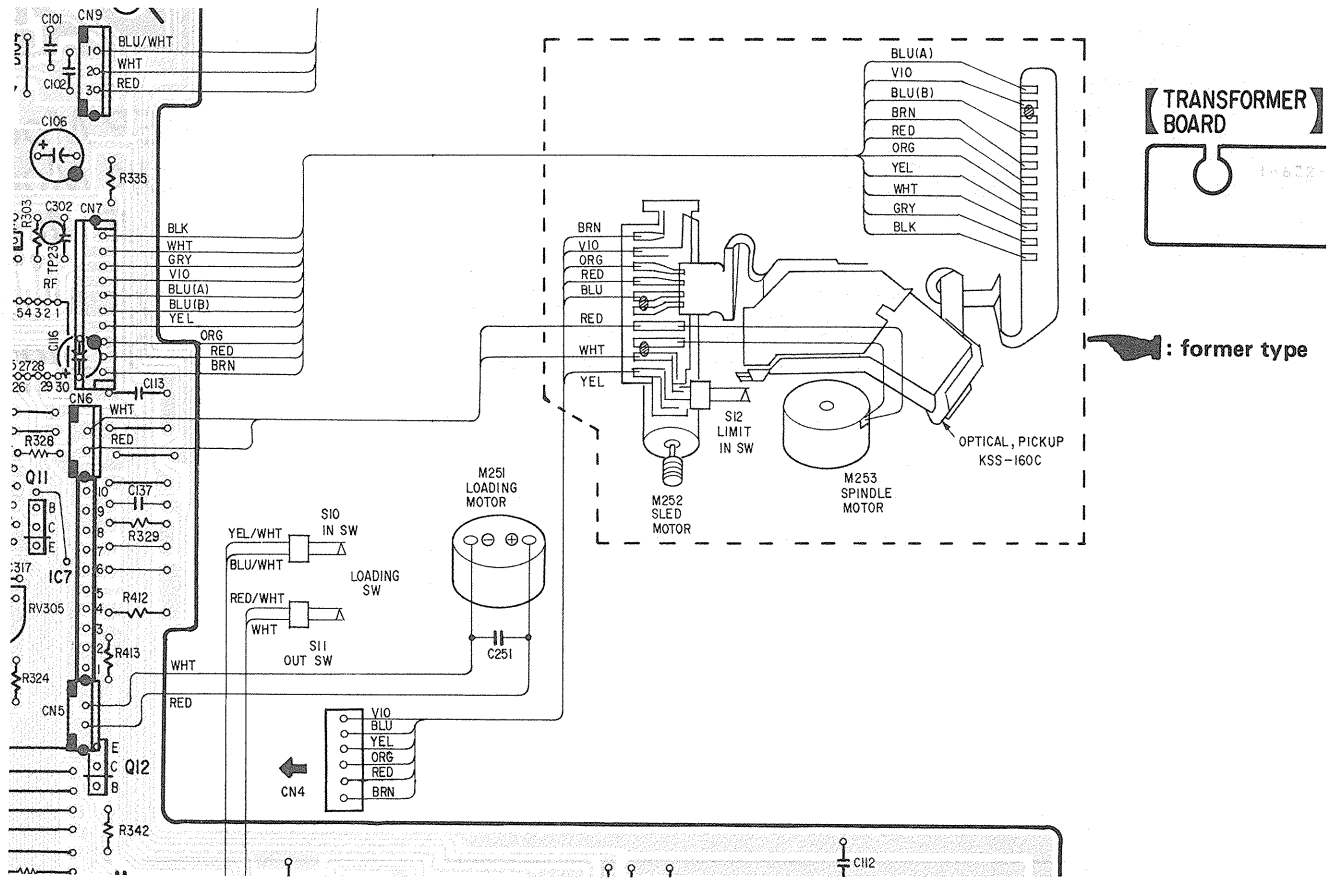

TRANSFORMER BOARD

: former type

● NEW TYPE (OPTICAL, PICKUP KSM-162ACN (MD assy'))

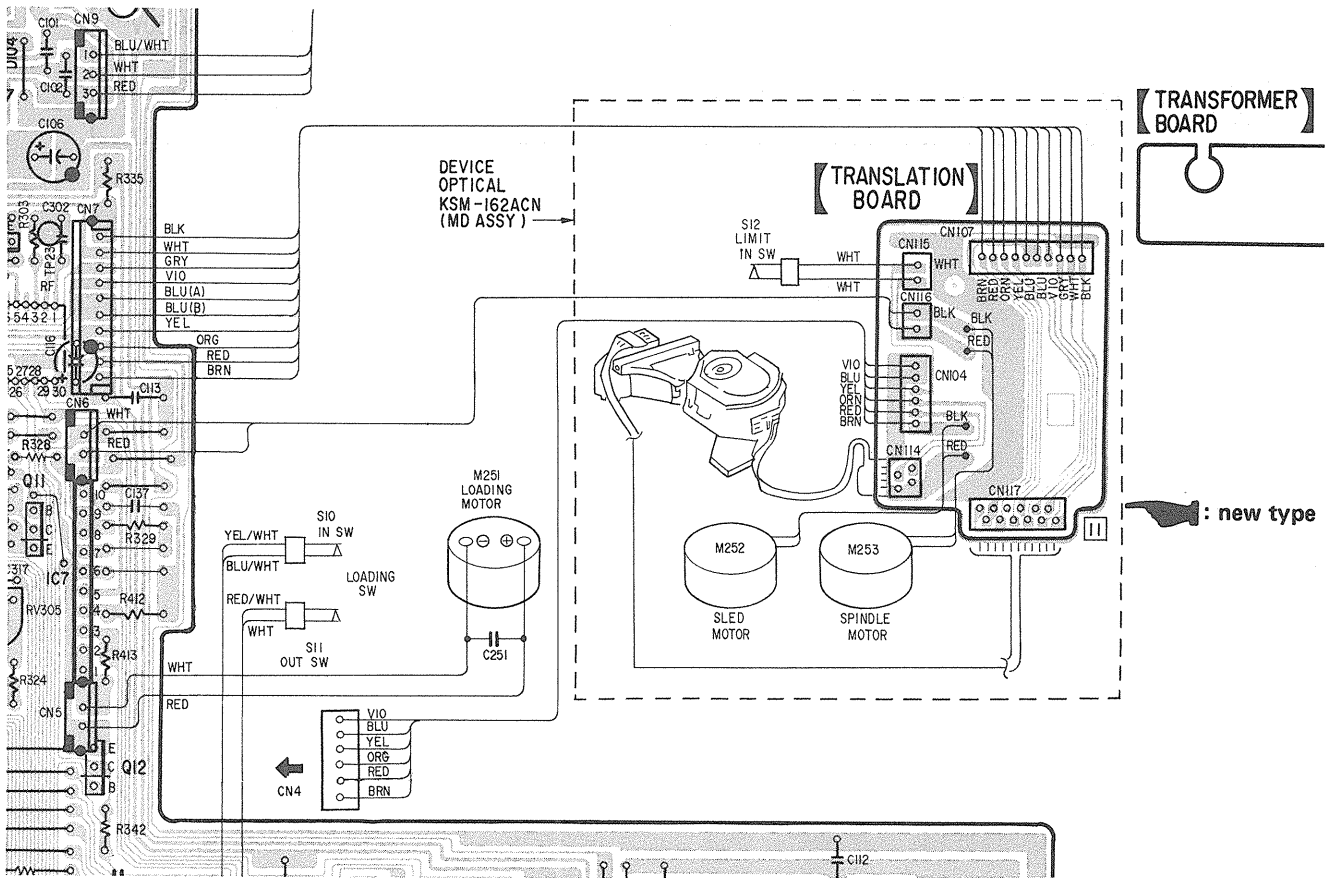

TRANSFORMER BOARD

: new type

(3) DISC TABLE (NEW TYPE)

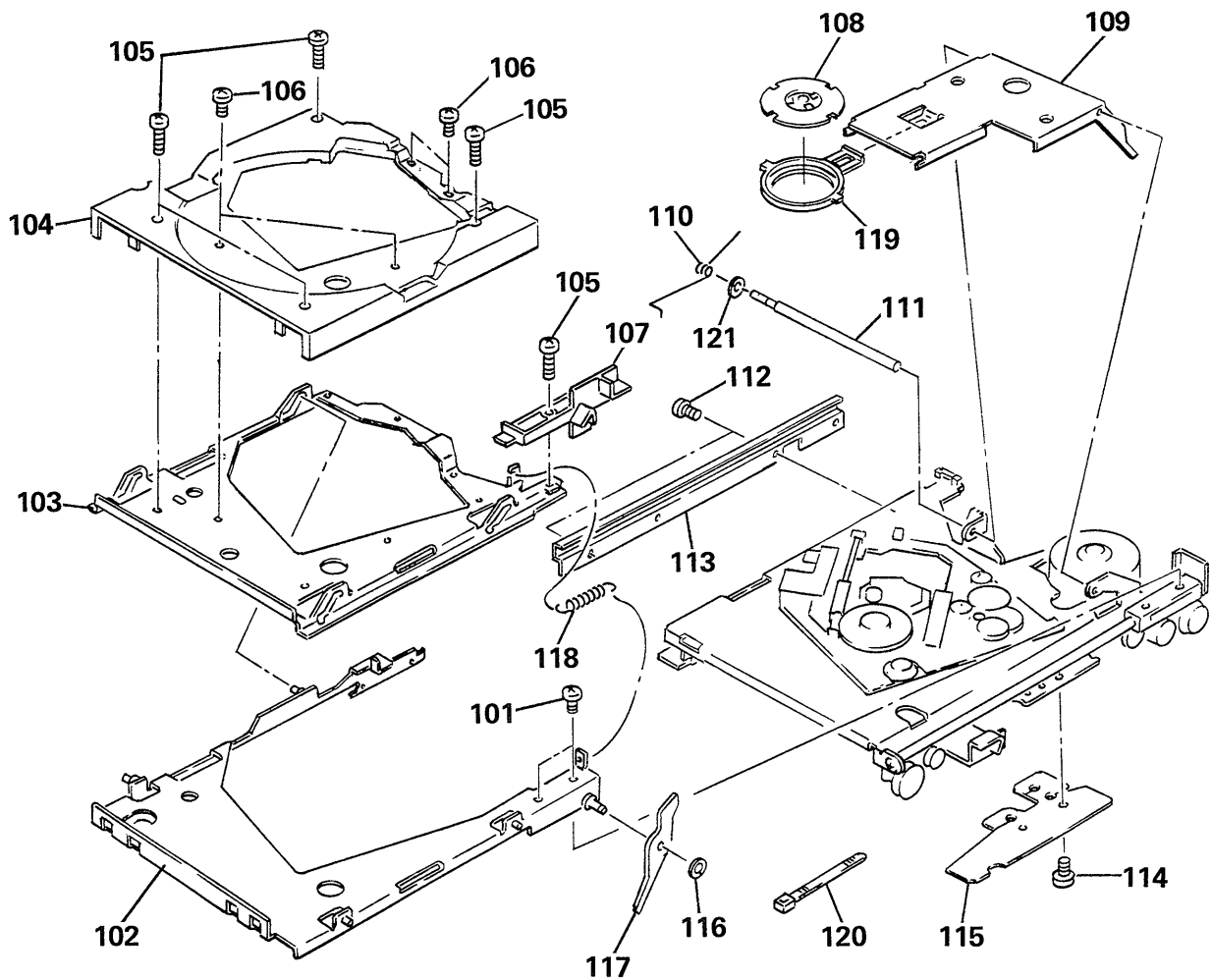

No.	Part No.	Description	Remarks	No.	Part No.	Description	Remarks
101	3-317-552-61	SCREW (M1.7X2.0)		111	*4-919-871-01	SHAFT (CHUCK ARM SHAFT)	
102	*X-4919-821-1	SLIDER (SLIDE TABLE) ASSY		112	7-627-850-18	SCREW, PRECISION +P 1.4X2.5	
103	*4-919-882-01	SLIDER (DISK TABLE)		113	*4-913-254-01	RAIL, GUIDE	
104	4-919-887-01	GUIDE (DISK GUIDE)		114	7-621-770-87	SCREW +BVTT 2.6X5 (S)	
105	7-627-850-68	SCREW, PRECISION +P 1.4X4		115	*4-919-853-01	STOPPER	
106	7-627-451-38	SCREW, PRECISION +K 1.4X2		116	3-681-678-00	WASHER, SLIT	
107	*4-919-880-01	GUIDE (S.D MOLD)		117	4-919-873-01	LEVER (S.D LEVER)	
108	X-4919-819-1	PLATE ASSY, CHUCK		118	4-919-821-01	SPRING, TENSION	
109	*4-919-883-02	LEVER (CHUCK ARM)		119	4-919-879-01	GUIDE (CHUCK PLATE)	
110	4-919-874-01	SPRING, TORSION		120	*3-337-402-01	BAND, BINDING	
				121	3-318-236-01	WASHER, POLY, SLIT	

REVISED

(4) BASE UNIT (NEW TYPE)  
(OPTICAL, PICKUP KSM-162ACN)

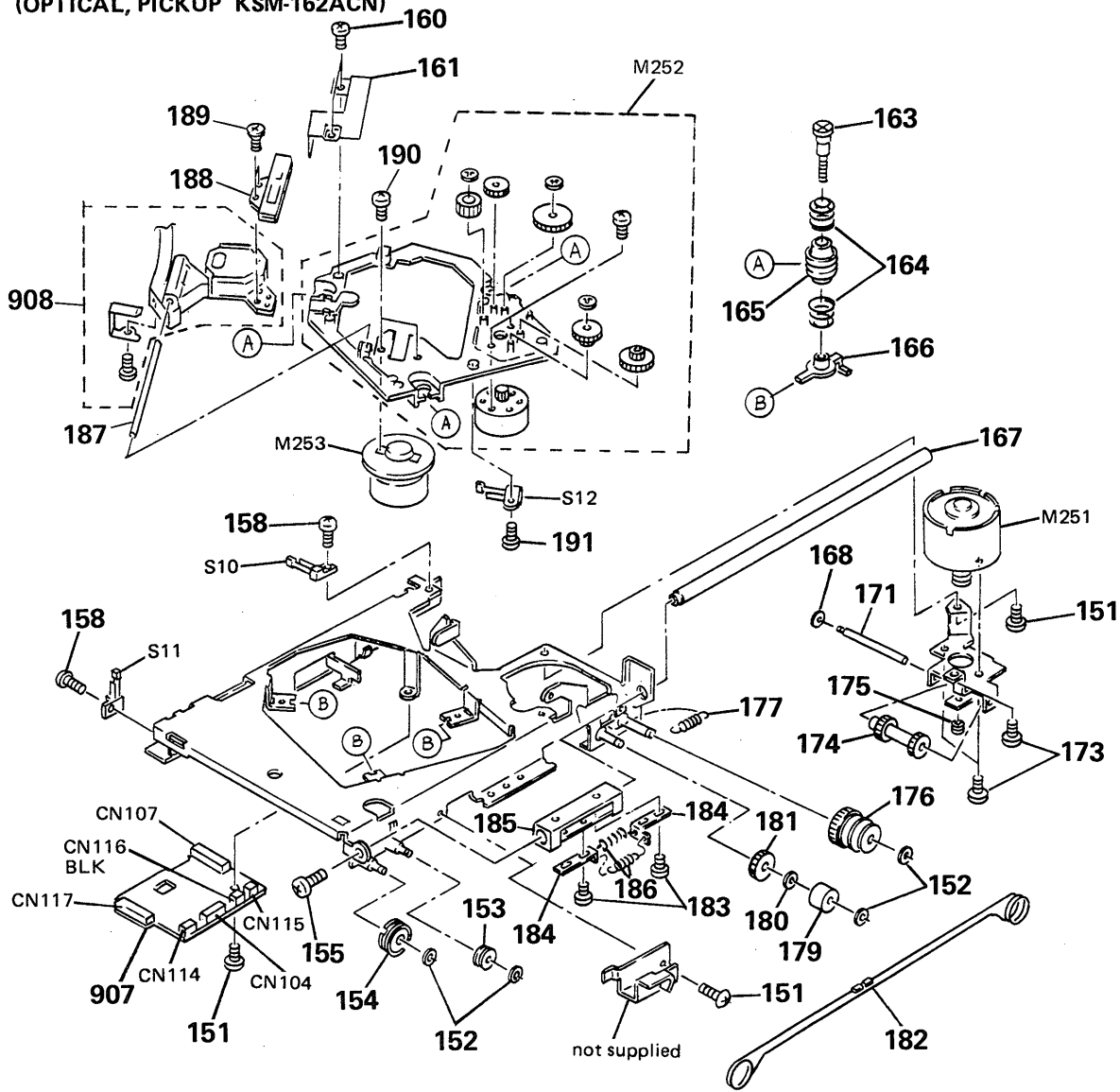

No.	Part No.	Description	Remarks
151	7-621-770-87	SCREW +BVTT 2.6X5 (S)	
152	3-681-678-00	WASHER, SLIT	
153	3-304-108-00	PULLEY	
154	4-913-211-01	PULLEY (A)	
155	7-621-772-00	SCREW +B 2X3	
158	3-305-528-11	SCREW, STOPPER	
160	3-893-942-21	SCREW (1.7X5), TAPPING (B)	
161	*4-919-876-01	COVER (FLEXIBLE RETAINER)	
163	4-919-875-01	SCREW (INSU SCREW)	
164	4-919-870-01	SPRING, COMPRESSION	
165	4-924-705-01	INSULATOR	
166	*4-919-872-01	BASE (INSULATOR), FITTING	
167	*4-913-210-01	SHAFT, SLIDE	
168	3-318-236-01	WASHER, POLY, SLIT	
170	*4-919-803-01	BRACKET (MOTOR)	
171	*4-919-809-01	SHAFT (DRIVING)	
173	4-885-599-00	SCREW, FITTING, REINFORCEMENT	
174	4-919-806-01	GEAR (DRIVING)	
175	2-622-801-01	RETAINER, THRUST	
176	X-4919-811-1	LIMITER ASSY	
177	3-570-556-00	SPRING, TENSION	
179	4-913-213-01	PULLEY (C)	
180	3-701-437-11	WASHER	
181	4-913-212-01	GEAR (B), DRIVING	

No.	Part No.	Description	Remarks
182	4-913-276-01	ROPE, WIRE	
183	3-311-772-00	SHAFT (A), STOPPER	
184	4-913-209-01	SLIDER, WT	
185	X-4913-219-1	BEARING ASSY, SLIDE	
186	3-578-277-00	SPRING, TENSION	
187	2-641-534-01	SHAFT	
188	X-2641-528-1	RACK ASSY	
189	2-641-383-01	SCREW, M1.7 x 4	
190	7-627-552-88	SCREW, +P 1.7 x2	
191	7-685-103-19	SCREW, +P 2 x 5	
907	*1-628-148-11	PC BOARD, TRANSLATION	
908	8-848-081-21	DEVICE, OPTICAL KSM-162A (RP)	
CN104	1-564-722-11	PIN, CONNECTOR (SMALL TYPE) 6P	
CN107	*1-564-726-11	PIN, CONNECTOR (SMALL TYPE) 10P	
CN114	1-565-953-11	CONNECTOR, FLEXIBLE 4P	
CN115	*1-564-517-11	PLUG, CONNECTOR 2P	
CN116	*1-564-517-11	PLUG, CONNECTOR 2P	
CN117	1-565-954-11	SOCKET, CONNECTOR 12P	
M251	X-4919-809-1	MOTOR ASSY	
M252	X-2641-539-1	MOTOR ASSY, SLED	
M253	X-2641-342-1	MOTOR ASSY, TT	
S10	1-553-226-00	SWITCH, LEAF	
S11	1-553-226-00	SWITCH, LEAF	
S12	1-570-112-11	SWITCH, LEAF	

Sony Corporation  
Audio Group

English  
89H0680-1  
Printed in Japan  
©1989.8

9-953-197-82  
(Including 9-953-197-81)  
(Including 9-953-197-92)

Published by A/V Engineering Service Dept.