

CDP-XA5ES

SERVICE MANUAL

AEP Model

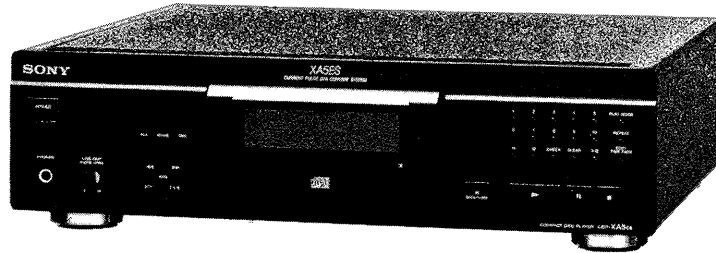

Photo : Black

Model Name Using Similar Mechanism	NEW
CD Mechanism Type	CDM32MB-12M (BLACK) CDM32MN-12M (GOLD)
Base Unit Type	BU-12M
Optical Pick-up Type	KSS-273A

Compact disc player

Laser	Semiconductor laser
Wavelength	780 – 790 nm
Frequency response	2 Hz to 20 kHz \pm 0.3 dB
Dynamic range	More than 100 dB
Harmonic distortion	Less than 0.0017%

Outputs

	Jack type	Maximum output level	Load impedance
LINE OUT (FIXED)	Phono jacks	2 V (at 50 kilohms)	Over 10 kilohms
LINE OUT (VARIABLE)	Phono jacks	2 V (at 50 kilohms)	Over 50 kilohms
DIGITAL OUT (OPTICAL)	Optical output connector	-18 dBm	Wave length: 660 nm
DIGITAL OUT (COAXIAL)	Coaxial output connector	0.5V _{p-p} (75 ohms)	75 ohms
PHONES	Stereo phone jack	28 mW	32 ohms

SPECIFICATIONS

General

Power requirements	220 V – 230 V AC, 50/60 Hz
Power consumption	20 W
Dimensions (approx.) (w/h/d)	430 × 125 × 370 mm (17 × 5 × 14 5/8 in.) incl. projecting parts
Mass (approx.)	13.5 kg (29 lbs 12 oz)

Supplied accessories

Audio cord (2 phono plugs – 2 phono plugs) (1)
Remote commander (remote) (1)
Sony SUM-3 (NS) batteries (2)
Stabilizer (1)

Design and specifications are subject to change without notice.



COMPACT DISC PLAYER
SONY[®]

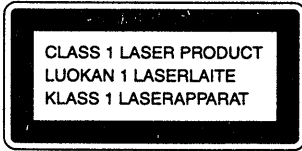

This appliance is classified as a CLASS 1 LASER product.

The CLASS 1 LASER PRODUCT MARKING is located on the rear exterior.

The following caution label is located inside the unit.

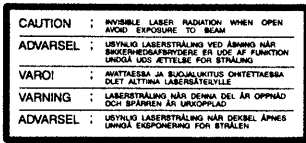

CAUTION
Use of controls or adjustments or performance of procedures other than those specified herein may result in hazardous radiation exposure.

MODEL IDENTIFICATION

— BACK PANEL —

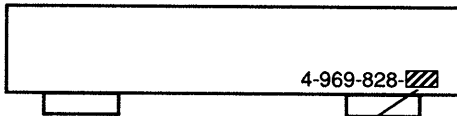

AEP Model : 1 (CED)
German Model : 2 (CEE)

SAFETY-RELATED COMPONENT WARNING !!

COMPONENTS IDENTIFIED BY MARK Δ OR DOTTED LINE WITH MARK Δ ON THE SCHEMATIC DIAGRAMS AND IN THE PARTS LIST ARE CRITICAL TO SAFE OPERATION. REPLACE THESE COMPONENTS WITH SONY PARTS WHOSE PART NUMBERS APPEAR AS SHOWN IN THIS MANUAL OR IN SUPPLEMENTS PUBLISHED BY SONY.

TABLE OF CONTENTS

Section	Title	Page
1.	SERVICING NOTE	3
2.	GENERAL	4
3.	DISASSEMBLY	
3-1.	Loading Panel	5
3-2.	Front Panel Assembly	6
3-3.	Panel (L), (R), (MD)	6
4.	ELECTRICAL BLOCK ADJUSTMENTS	7
5.	DIAGRAMS	
5-1.	IC Pin Functions	
	• IC201 System Control (CXP84124-025Q)	9
	• Main Ports	11
5-2.	Circuit Boards Location	12
5-3.	Block Diagram	13
5-4.	Semiconductor Lead Layouts	16
5-5.	Printed Wiring Board — Servo Section —	17
5-6.	Schematic Diagram — Servo Section —	19
5-7.	Printed Wiring Board — Main Section —	23
5-8.	Schematic Diagram — Main Section —	27
5-9.	Printed Wiring Board — Panel Section —	32
5-10.	Schematic Diagram — Panel Section —	34
6.	EXPLODED VIEWS	
6-1.	Loading Panel Section	37
6-2.	Front Panel Section	38
6-3.	Chassis Section	39
6-4.	CD Mechanism Section 1 (CDM32MN-12M/CDM32MB-12M)	40
6-5.	CD Mechanism Section 2 (CDM32MN-12M/CDM32MB-12M)	41
6-6.	Base Unit Section (BU-12M)	42
7.	ELECTRICAL PARTS LIST	43

Notes on chip component replacement

- Never reuse a disconnected chip component.
- Notice that the minus side of a tantalum capacitor may be damaged by heat.

Flexible Circuit Board Repairing

- Keep the temperature of the soldering iron around 270 °C during repairing.
- Do not touch the soldering iron on the same conductor of the circuit board (within 3 times).
- Be careful not to apply force on the conductor when soldering or unsoldering.

SECTION 1

SERVICING NOTE

HOW TO OPEN THE DISC TRAY WHEN POWER SWITCH TURNS OFF

Insert a tapering driver into the aperture of the unit bottom, and turn in the direction of arrow (to OUT direction).

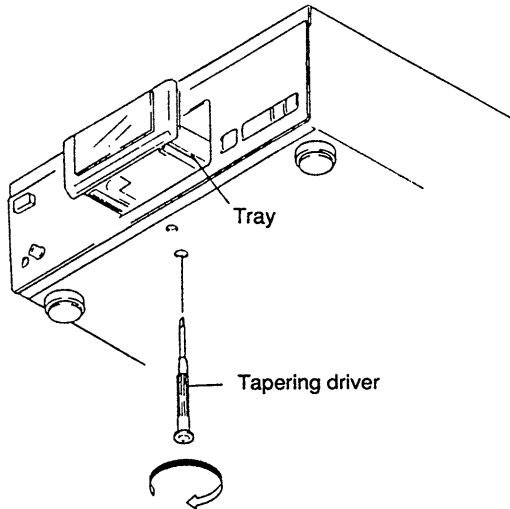

* To close the disc tray, turn the driver in the reverse direction (to IN direction).

NOTES ON HANDLING THE OPTICAL PICK-UP BLOCK OR BASE UNIT

The laser diode in the optical pick-up block may suffer electrostatic break-down because of the potential difference generated by the charged electrostatic load, etc. on clothing and the human body.

During repair, pay attention to electrostatic break-down and also use the procedure in the printed matter which is included in the repair parts.

The flexible board is easily damaged and should be handled with care.

NOTES ON LASER DIODE EMISSION CHECK

The laser beam on this model is concentrated so as to be focused on the disc reflective surface by the objective lens in the optical pick-up block. Therefore, when checking the laser diode emission, observe from more than 30 cm away from the objective lens.

LASER DIODE AND FOCUS SEARCH OPERATION CHECK

Carry out the "S curve check" in "CD section adjustment" and check that the S curve waveform is output three times.

PREPARATION FOR ADJUSTMENT AND MESUREMENT

Perform connecting the IC261 ② pin of SERVO board to the line of +5V because this unit does not work without the stabilizer structurally.

SERVO BOARD — Conductor side —

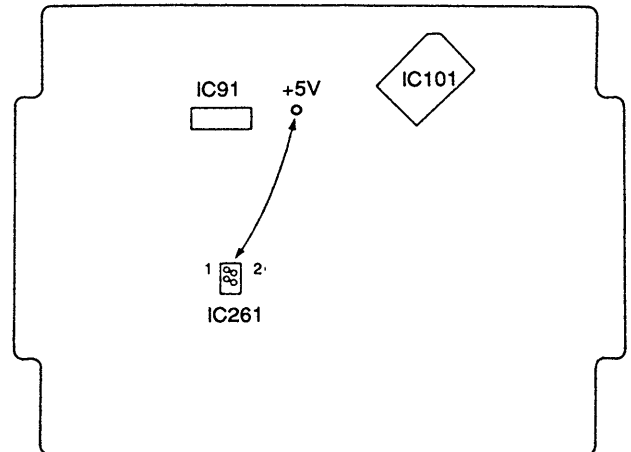

SECTION 2 GENERAL

Identifying the Parts

Front Panel

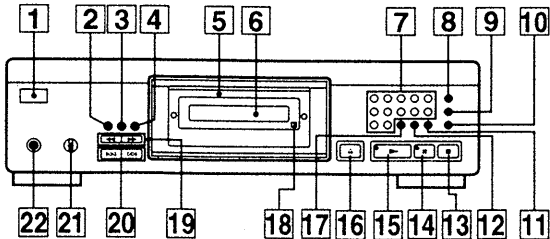

- 1 Power switch
- 2 FILE button
- 3 ERASE button
- 4 TIME button
- 5 Disc tray
- 6 Display window
- 7 Numeric buttons
- 8 PLAY MODE button
- 9 REPEAT button
- 10 EDIT/TIME FADE button
- 11 >12 (over 12) button
- 12 CLEAR button
- 13 ■ (stop) button
- 14 || (pause) button
- 15 ► (play) button
- 16 ▲ OPEN/CLOSE button
- 17 CHECK button
- 18 Remote sensor
- 19 ◀▶ (manual search) buttons
- 20 ◀◀▶▶ AMS* buttons

* AMS is the abbreviation of Automatic Music Sensor.

Remote Commander (RM-D921)

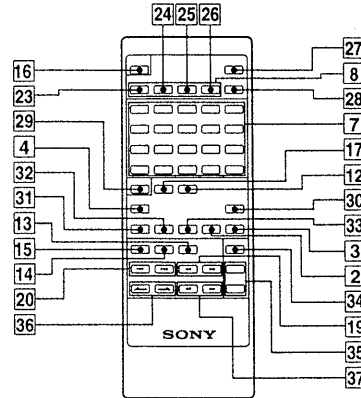

- 21 LINE OUT/PHONE LEVEL control
- 22 PHONES jack
- 23 CONTINUE button
- 24 SHUFFLE button
- 25 PROGRAM button
- 26 C. INDEX button
- 27 DISPLAY MODE button
- 28 MUSIC SCAN button
- 29 >20 (over 20) button
- 30 PEAK SEARCH button
- 31 REPEAT (repeat/A-B repeat clear) button
- 32 A ↔ B repeat button
- 33 AUTO SPACE button
- 34 FADER (fade in/fade out) button
- 35 LINE OUT LEVEL (line out/headphones level) buttons
- 36 ← → INDEX buttons
- 37 ◀◀▶▶ SLOW (low speed manual search) buttons

Display Window

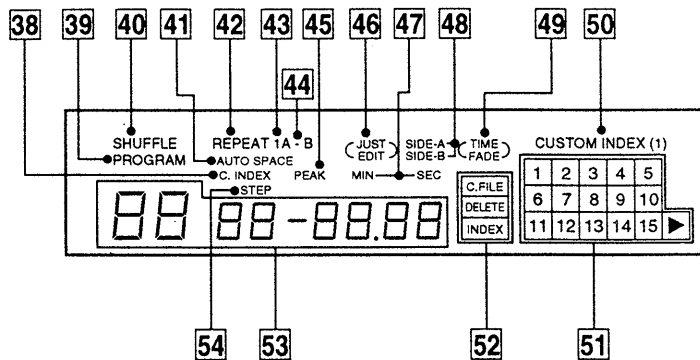

- 38 C. INDEX
- 39 PROGRAM
- 40 SHUFFLE
- 41 AUTO SPACE
- 42 REPEAT
- 43 REPEAT 1
- 44 REPEAT A-B
- 45 PEAK
- 46 JUST EDIT
- 47 MIN/SEC
- 48 SIDE A/SIDE B
- 49 TIME FADE
- 50 CUSTOM INDEX (1)
- 51 1 — 15 ►
- 52 C FILE/DELETE/INDEX
- 53 DISPLAY
- 54 STEP

SECTION 3 DISASSEMBLY

Note : Follow the disassembly procedure in the numerical order given.

3-1. LOADING PANEL

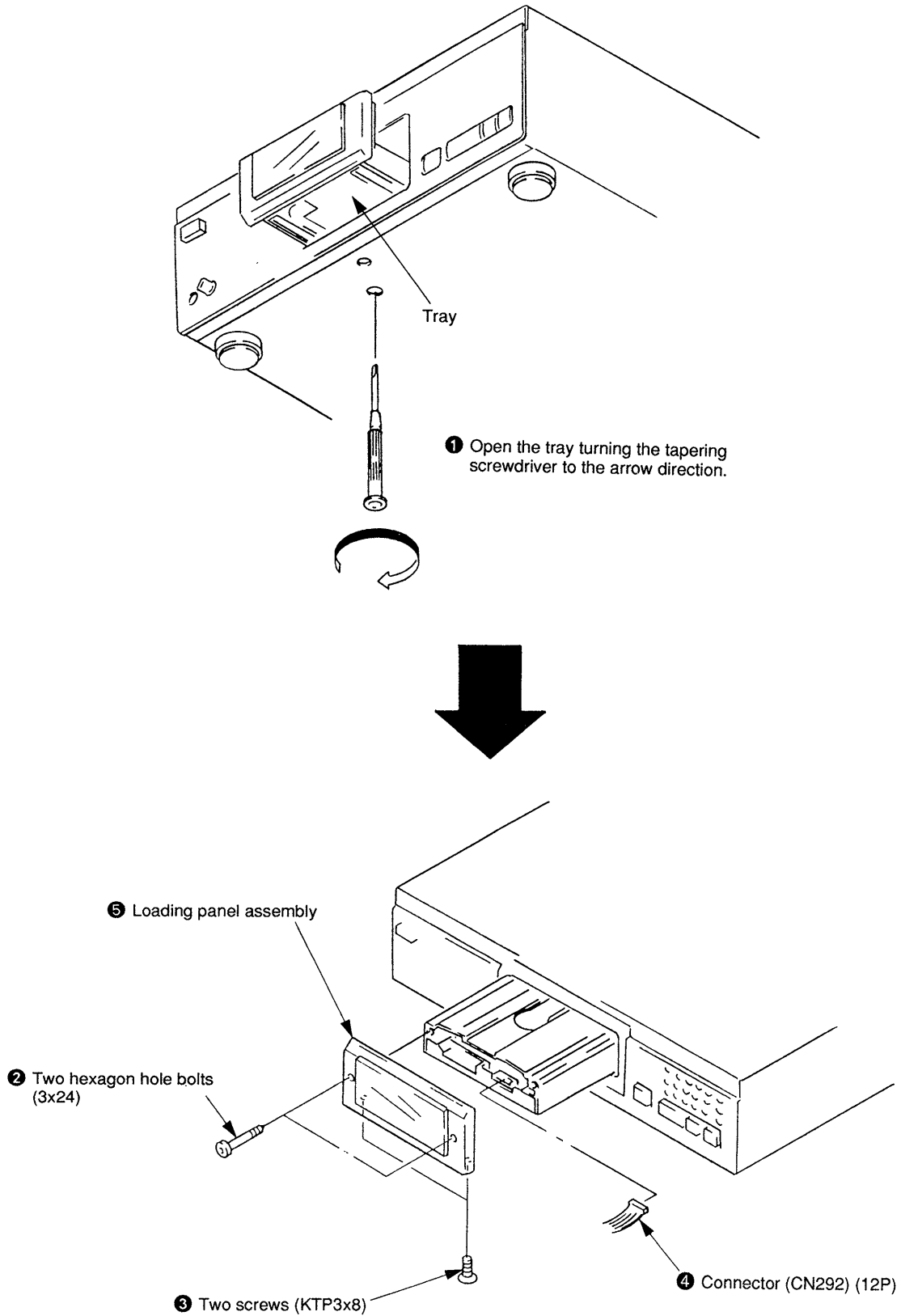

Note : Install in order **3** right → **3** left → two of **2**.

3-2. FRONT PANEL ASSEMBLY

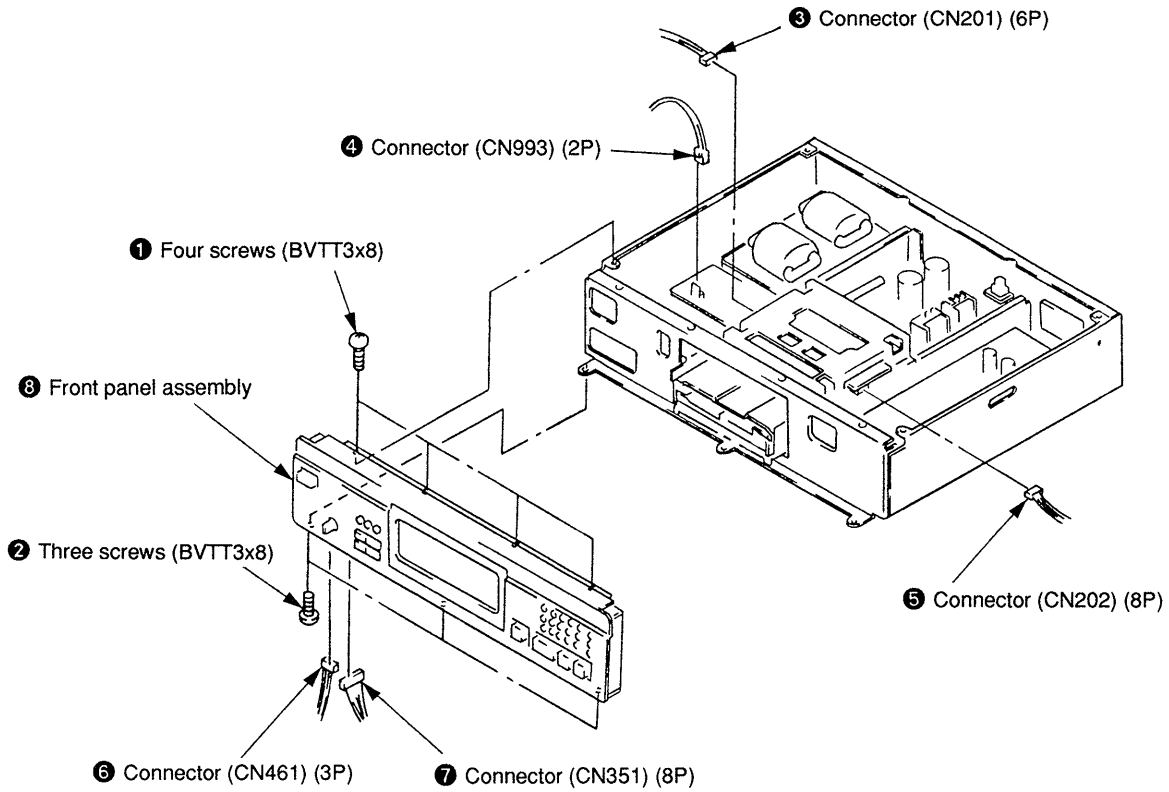

3-3. PANEL (L), (R), (MD)

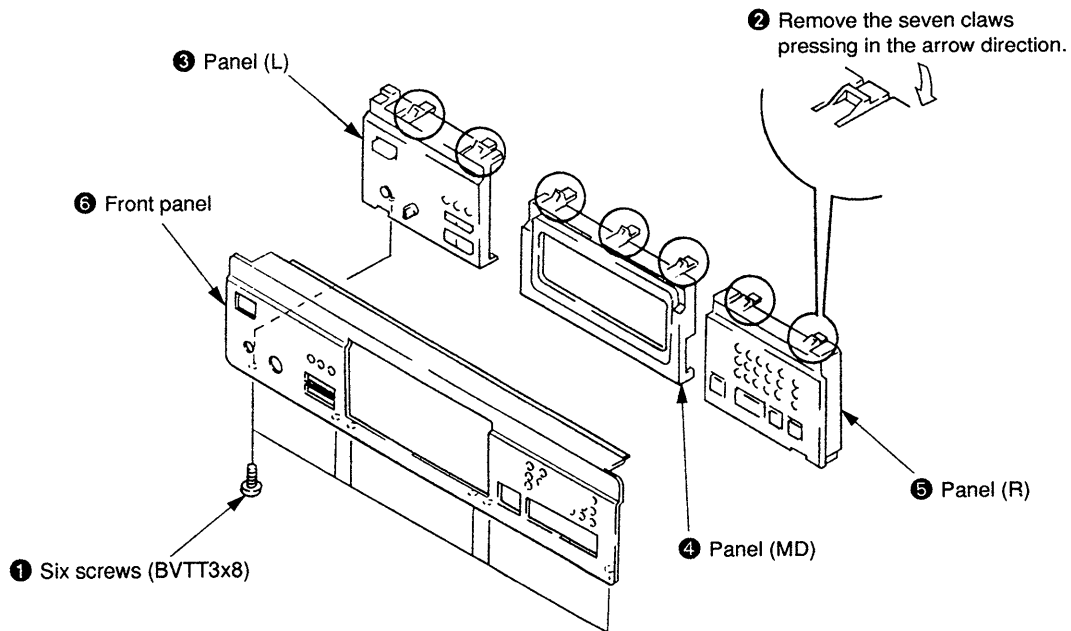

SECTION 4

ELECTRICAL BLOCK ADJUSTMENTS

Note :

1. CD Block basically constructed to operate without adjustment. Therefore, check each item in order given.
2. Use YEDS-18 disc (3-702-101-01) unless otherwise indicated.
3. Use an oscilloscope with more than 10MΩ impedance.
4. Clean an object lens by an applicator with neutral detergent when the signal level is low than specified value with the following checks.

S Curve Check

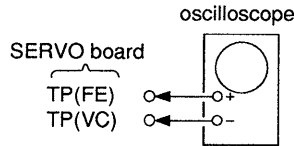

Procedure :

1. Connect oscilloscope to test point TP (FE).
2. Connect between test point TP (FEI : IC101 ⑳ pin) and TP (VC) by lead wire.
3. Turned Power switch on.
4. Put disc (YEDS-18) in and turned Power switch on again and actuate the focus search. (actuate the focus search when disc table is moving in and out.)
5. Check the oscilloscope waveform (S-curve) is symmetrical between A and B. And confirm peak to peak level within 3 ± 1 Vp-p.

S-curve waveform

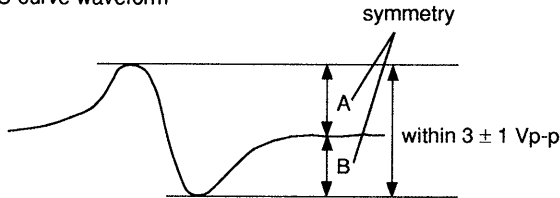

6. After check, remove the lead wire connected in step 2.

Note :

- Try to measure several times to make sure that the ratio of A : B or B : A is more than 10 : 7.
- Take sweep time as long as possible and light up the brightness to obtain best waveform.

RF Level Check

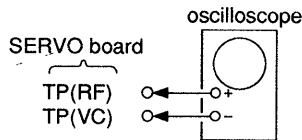

Procedure :

1. Connect oscilloscope to test point TP (RF).
2. Turned Power switch on.

3. Put disc (YEDS-18) in and playback.
4. Confirm that oscilloscope waveform is clear and check RF signal level is correct or not.

Note :

Clear RF signal waveform means that the shape “◇” can be clearly distinguished at the center of the waveform.

RF signal waveform

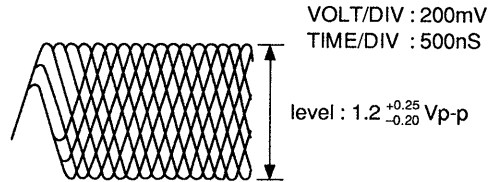

E-F Balance (Traverse) Check

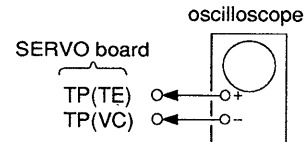

Procedure :

1. Connect test point TP (ADJ) to ground and TP(TEI : IC101 ㉓ pin) to TP (VC) with a lead wire.
2. Connect oscilloscope to test point TP (TE).
3. Turned Power switch on.
4. Put disc (YEDS-18) in and playback.
5. Confirm that the oscilloscope waveform is symmetrical on the top and bottom in relation to 0V dc, and check this level.

Traverse waveform



6. Remove the lead wire connected in step 1.

RF PLL Free-run Frequency Check

Procedure :

1. Connect frequency counter to test point (PLK) with lead wire.

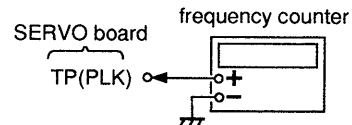

2. Turned Power switch on.
3. Confirm that reading on frequency counter is 4.3218MHz.

Skew Adjustment

Do not perform the skew adjustment when not using attached stabilizer to a set.

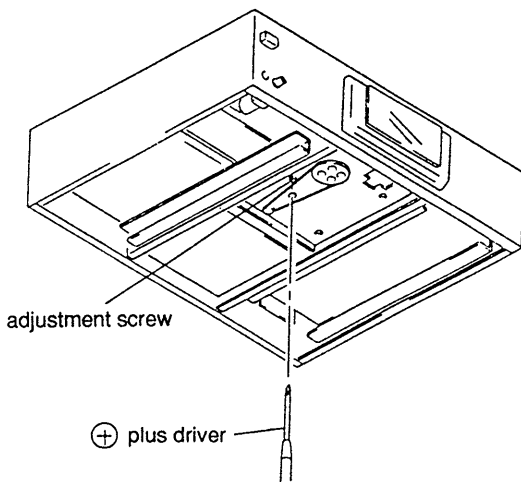
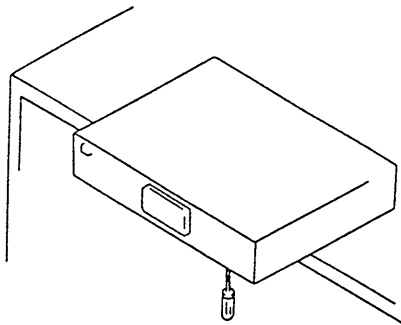
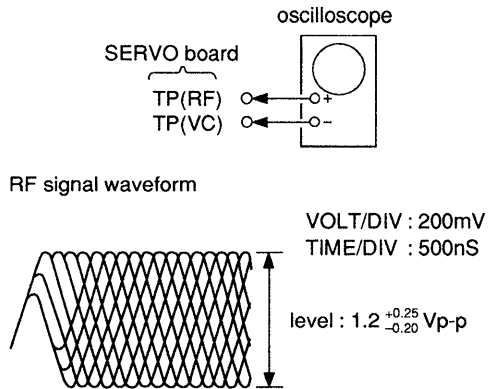

1. Remove the bottom board, put one third of the unit out from the desk.
2. Connect oscilloscope to test point TP (RF).
3. Turn Power switch on.
4. Put disc (YEDS-18) in and playback.
5. Adjust to be clear the waveform of the oscilloscope turning the adjustment screw with a ⊕ screwdriver.

Note :

- A clear RF signal waveform means that the shape “◇” can be clearly distinguished at the center of the waveform.
6. After the adjustment, lock the adjustment screw.

[SERVO BOARD] — Conductor side —

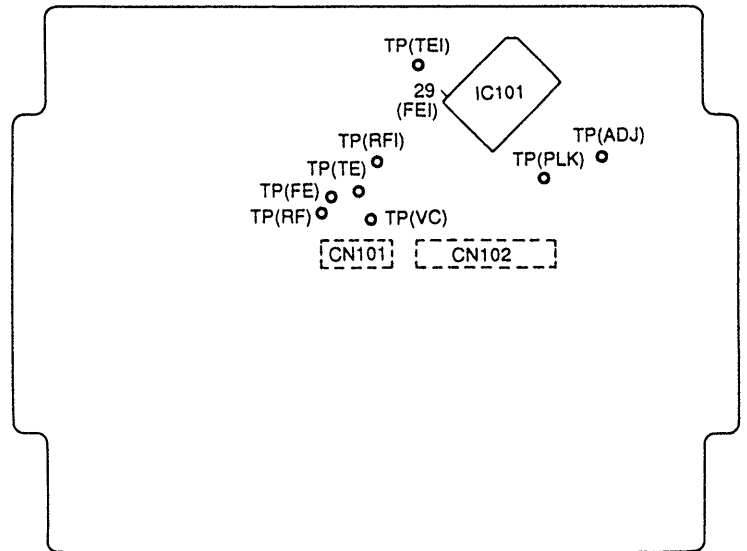

SECTION 5 DIAGRAMS

5-1. IC PIN FUNCTIONS

• IC201 System Control (CXP84124-025Q)

Pin No.	Pin Name	I/O	Function
1	A3	O	} Output of address to S.RAM (LH5160TG)
2	A4	O	
3	A5	O	
4	A6	O	
5	A7	O	
6	A8	O	
7	A9	O	
8	A10	O	
9	A11	O	
10	A12	O	
11	WE	O	Output of write enable to S.RAM
12	—	O	} Not used (open)
13	—	O	
14	LED-PLAY	O	PLAY Lamp output "H": ON
15	LED-PAUSE	O	PAUSE Lamp output "H": ON
16	LED-D/O ON	O	DIGITAL OUT Lamp output
17	SPDL-MUTE	O	Drive IC MUTE output for spindle. "L": ON
18	SHIFT-ON/OFF	I	D/F mode control input
19	VOL UP	O	Headphone motor volume up output
20	VOL DOWN	O	Headphone motor volume down output
21	BLK	O	Blank output to fluorescent indicator tube driver. (LC7570E). When the indicator tube lights: "H"
22	D0	O	} Serial data output to fluorescent indicator tube driver. (LC7570E).
23	D1	O	
24	D2	O	
25	CLK	O	Clock output to fluorescent indicator tube driver. (LC7570E).
26	WR	O	Latch output to fluorescent indicator tube driver. (LC7570E).
27	SENSOR SW	O	Senser power supply ON/OFF control output for stabilizer detection
28	SENSOR	I	Stabilizer detection input
29	LIMIT OUT	I	Sled out switch input "L": SW ON
30	RESET	I	Microcomputer reset input
31	XTAL I	I	} Oscillator connector pin (10 MHz)
32	XTAL O	O	
33	V _{ss}	—	Connected to GND
34	—	—	} Not used (open)
35	—	—	
36	AV _{ss}	—	A/D converter GND
37	AV _{REF}	—	A/D converter reference voltage input (Connected to +5V)
38	K0	I	} Key data input (A/D input). When the key is not pressed: "H"
39	K1	I	
40	K2	I	

Pin No.	Pin Name	I/O	Function
41	K3	I	} Key data input (A/D input). When the key is not pressed: "H"
42	K4	I	
43	K5	I	Model distinction
44	ADJ/AFJ	I	Test mode input. The equipment is fixed at "H"
45	IN/OUT SW	I	Loading IN/OUT switch input
46	SCLK	O	Serial read out data read out clock output to CXD2515Q
47	PRGL	O	Program latch to digital filter
48	CLK	O	Serial data transfer clock output to CXD2515Q, CXD8504M
49	SENSE	I	SENSE signal input from CXD2515Q
50	DATA	O	Serial data output to CXD2515Q, CXD8504M
51	SQCK	O	Sub code Q read out clock output to CXD2515Q
52	SUBQ	I	Sub code Q data input from CXD2515Q
53	TEST	O	Not used (open)
54	SEL 1	I	} Model distinction
55	SEL 0	I	
56	RMIN	I	Remote control signal input
57	TIMER	I	Not used
58	TEST	O	} Not used (open)
59	TEST	O	
60	SCOR	I	Sub code sync input from CXD2515Q. Start to read out the sub code receiving this signal
61	AMUTE	O	Analog mute output. "H": mute on
62	LDON	O	Laser diode ON/OFF control output "H": ON
63	XLT	O	Serial data latch output to CXD2515Q
64	LOAD OUT	O	Output to rotate loading motor in the loading out direction. "H": OUT
65	LOAD IN	O	Output to rotate loading motor in the loading in direction. "H": IN
66	DOUT	O	Digital output ON/OFF control output
67	DMUTE	O	Muting control output
68	D0	I/O	} Input and output of data signal with S.RAM (LH5160TG)
69	D1	I/O	
70	D2	I/O	
71	D3	I/O	
72	VDD	I	Power supply terminal (+5V)
73	NC	-	Connected to +5V
74	D4	I/O	} Input and output of data signal with S.RAM (LH5160TG)
75	D5	I/O	
76	D6	I/O	
77	D7	I/O	
78	A0	O	} Address signal output to S.RAM (LH5160TG)
79	A1	O	
80	A2	O	

• Main Ports

⑰ SPINDLE MUTE

From the viewpoint of performance of the set, the disc must not move nor sway when the disc table opens. These problems however occur in the actual case due to the offset voltage generated and the voltage generated because of the positional relation between the BSL coil and Hall element. The BSL (IC104, IC105) driver is therefore muted while the tray is open. Pin ⑰ provides the timing for this.

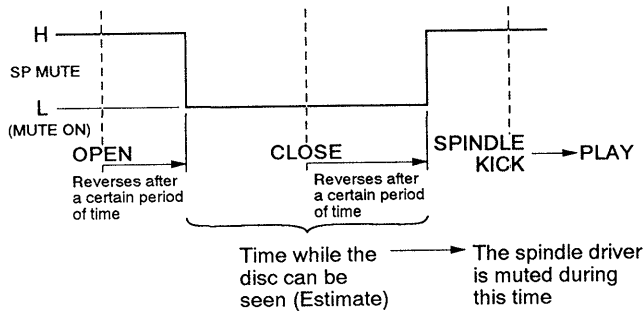

⑳ SENSER

The results of the detection of IC261 IS471F is output to this pin. It becomes L when there is no stabilizer (when light reaches). The next process of imposing the next focus is not performed. (Effective only when ㉑ is H.) Therefore, it must be noted that if PLAY is performed when the servo mount at the top of the CDM is not assembled properly, the detection circuit operates and this pin does not operate. It does not operate, refer to 1. Service Note "Preparations for Adjustment and Measurement" on page 3.

㉑ BLANK

This port is required because the display tube in this set static-lights up and a dedicated screwdriver is required. It is basically a RESET pin. But as problems will occur if used also as RESET, timings are specially provided using the microprocessor.

㉒ SENSER SW

As IC261 IS471F operate in pulse as shown in the figure, the sound quality may be affected if operated constantly. As the purpose of IC261 is to detect if the presence of the stabilizer, it should be operated only when the tray is drawn in. IC261 operates as it is H only at this time. Normally it is L.

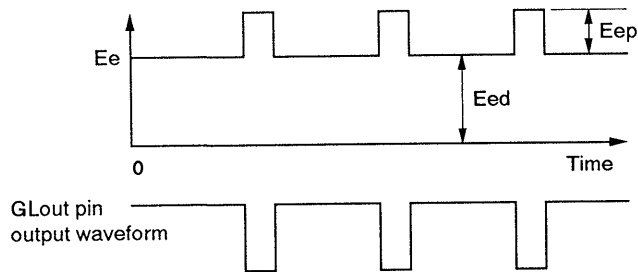

* Eep is the luminance of the signal light tuned with the low level timing of the GLout pin output.
Eed is the luminance of the d.c. light. The light source is the infrared-emitting diode ($\lambda = 940 \text{ nm}$).

5-2. CIRCUIT BOARDS LOCATION

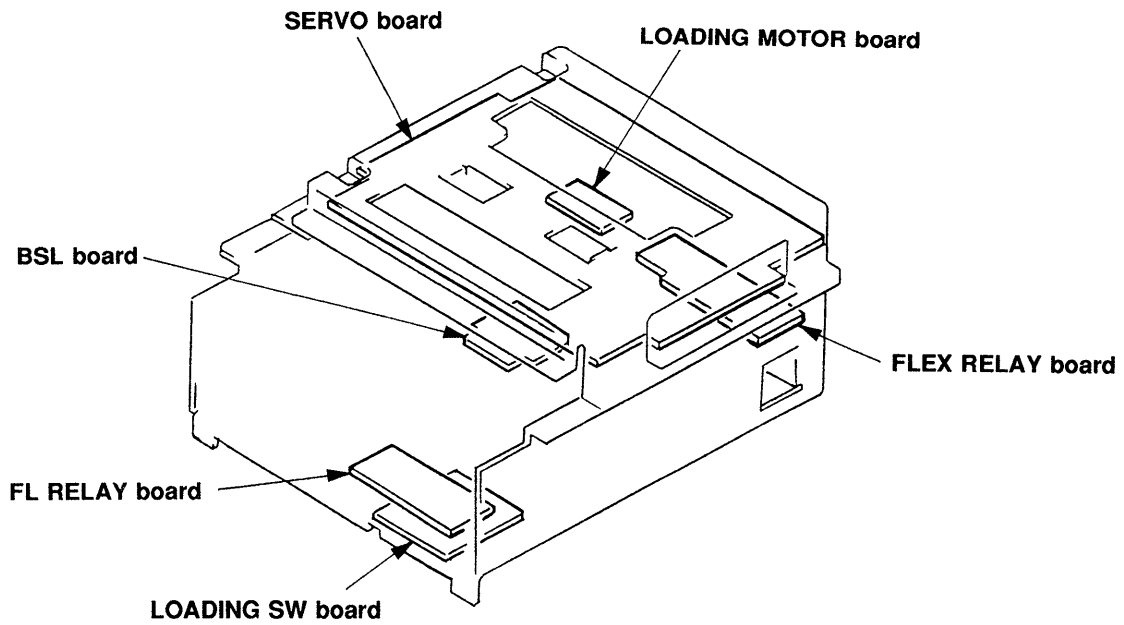
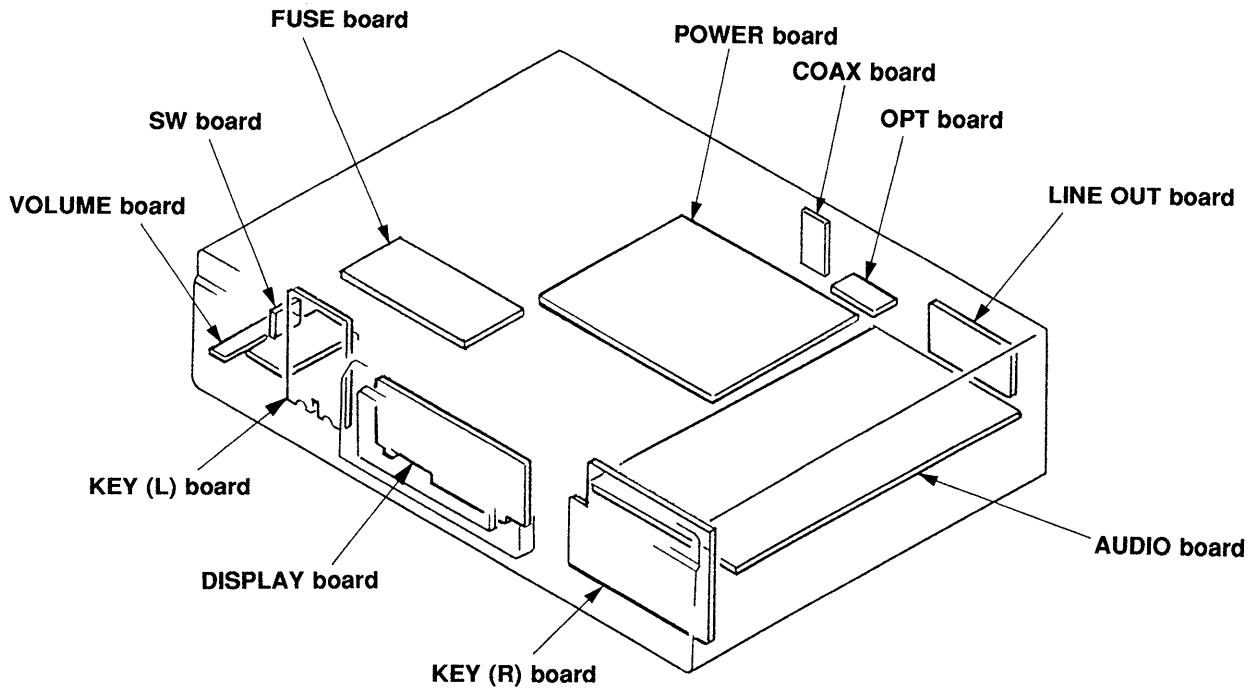

5-3. BLOCK DIAGRAM

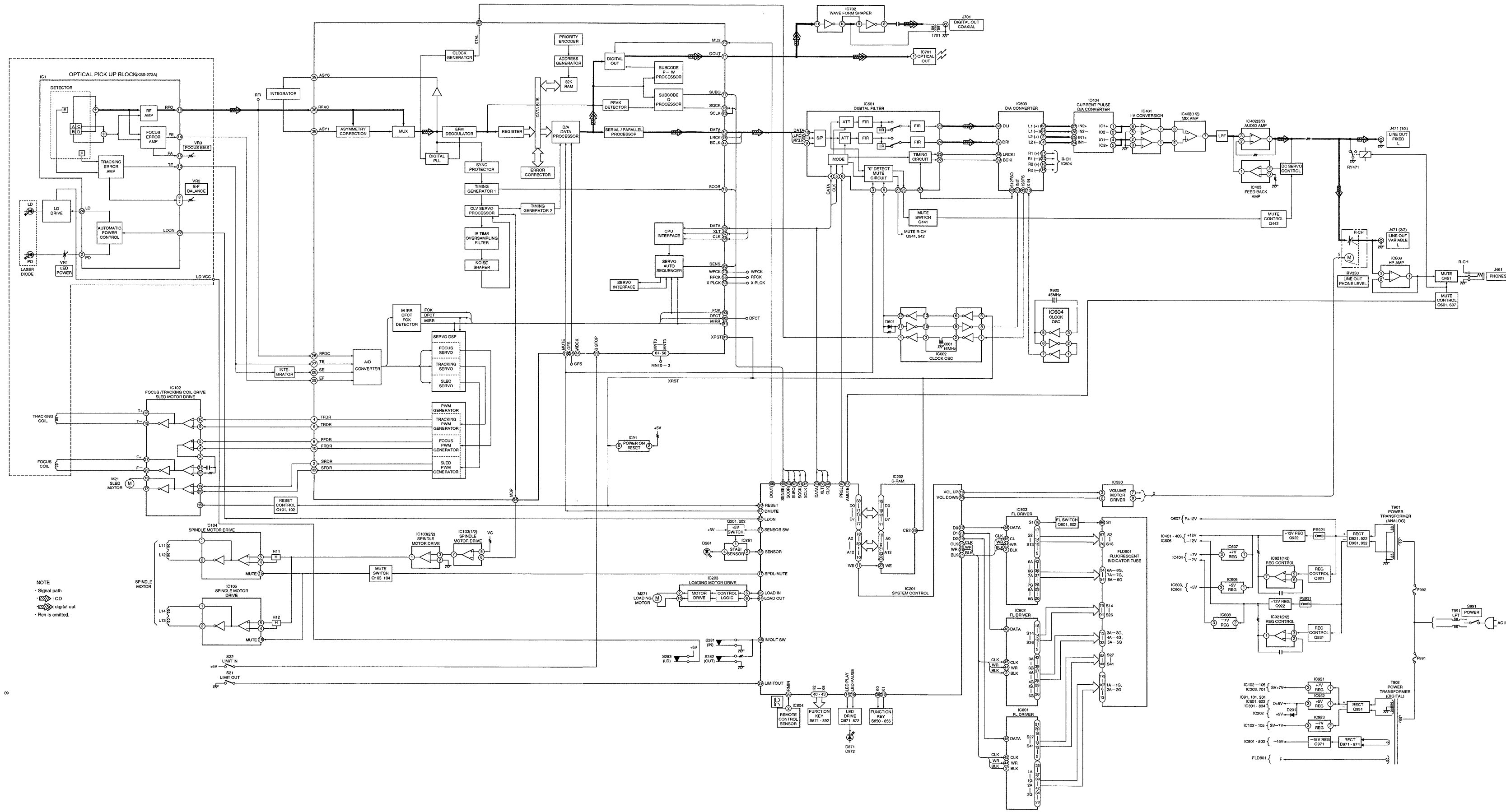

5-4. SEMICONDUCTOR LEAD LAYOUTS

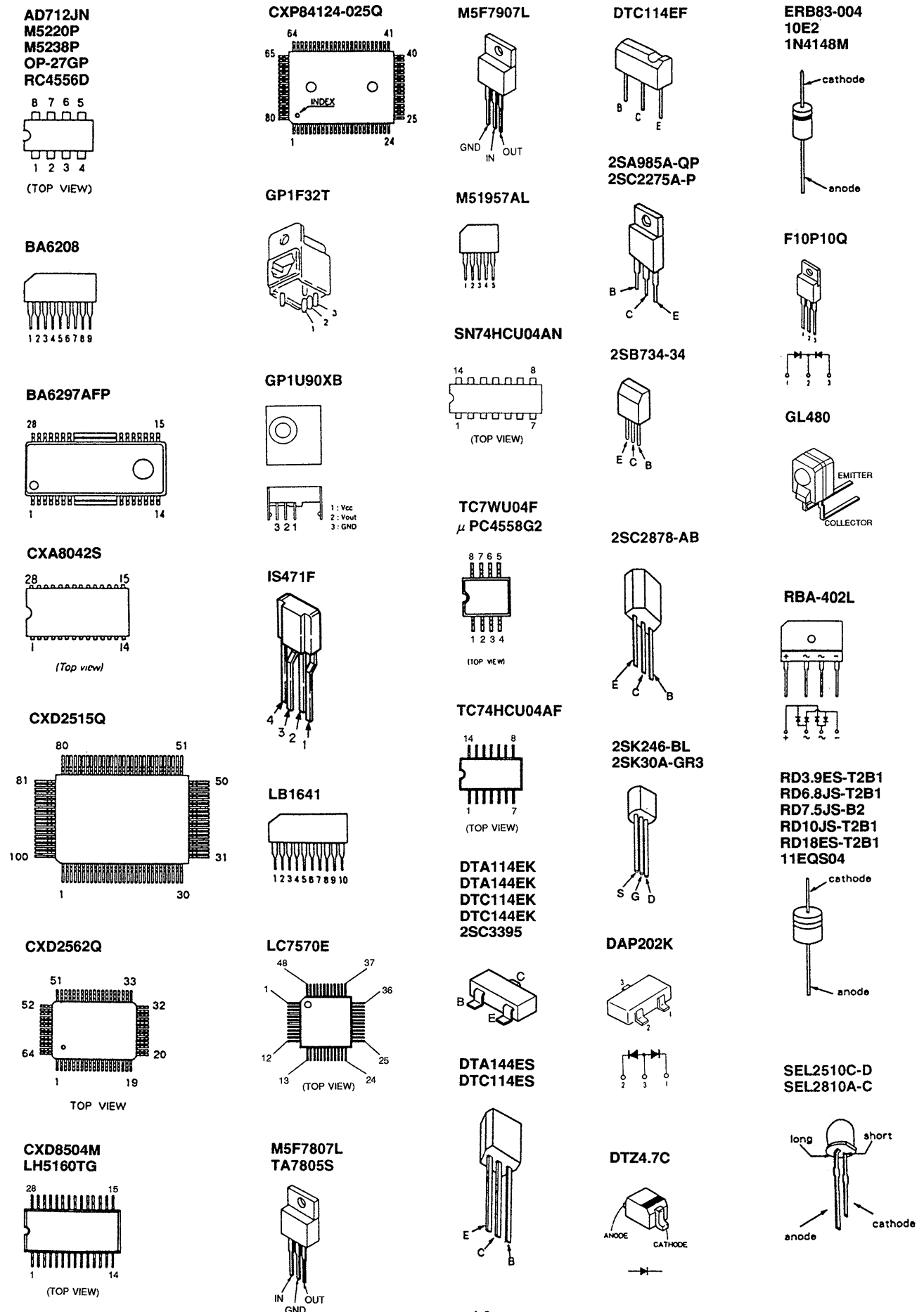

5-5. PRINTED WIRING BOARD — SERVO SECTION —
• See page 12 for Circuit Boards Location.

• Semiconductor Location

Ref. No.	Location
D201	E-6
D202	D-4
D261	E-8
H11	I-4
H12	I-3
IC91	B-6
IC101	B-8
IC102	D-4
IC103	B-4
IC104	F-5
IC105	F-6
IC201	F-9
IC202	F-7
IC203	C-4
IC261	D-6
IC701	H-10
IC702	H-12
Q101	C-5
Q102	B-5
Q103	F-4
Q104	E-4
Q201	E-7
Q202	E-7

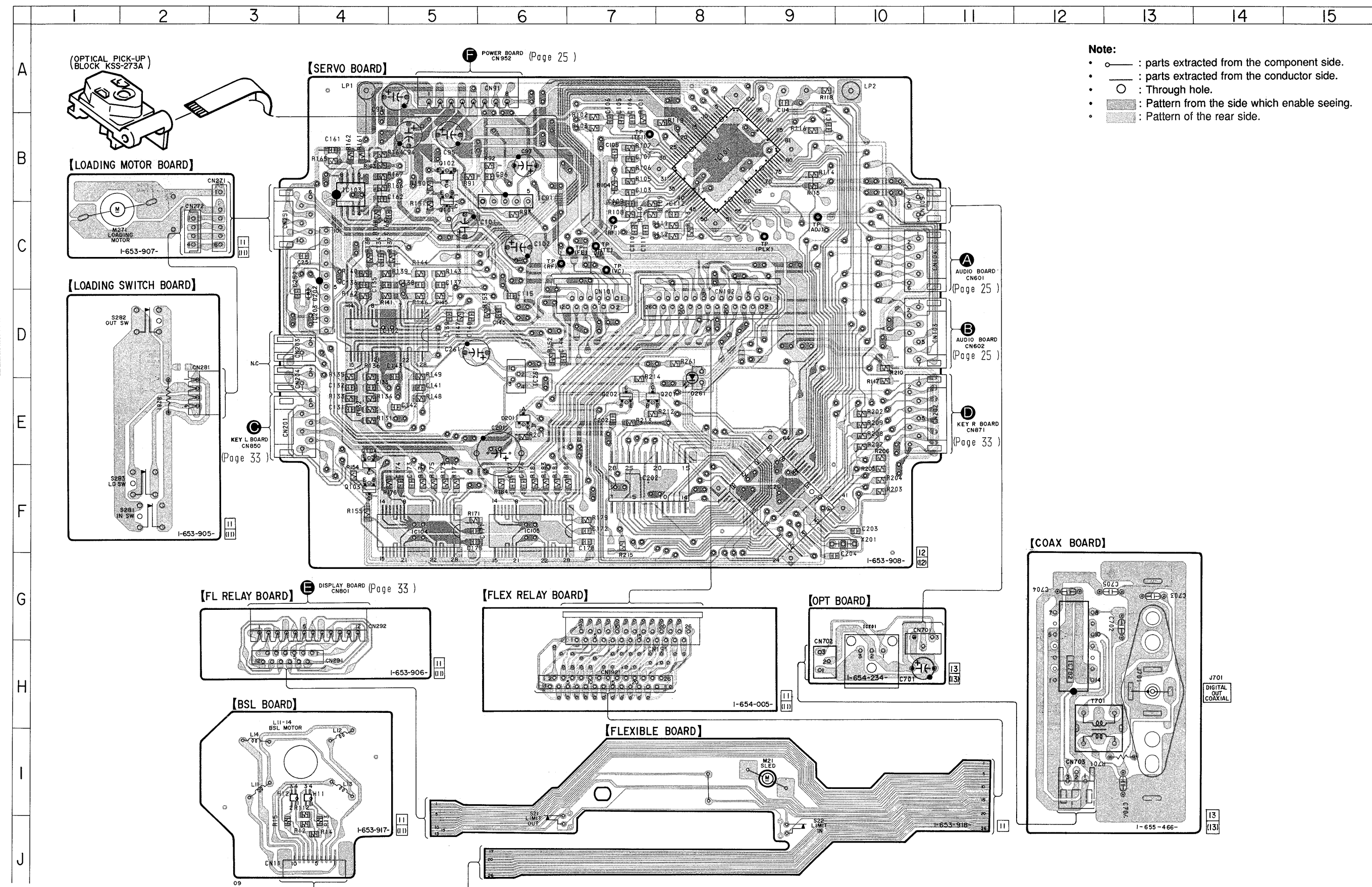

5-6. SCHEMATIC DIAGRAM — SERVO SECTION —
• See page 9 for IC Pin Functions. (IC201)

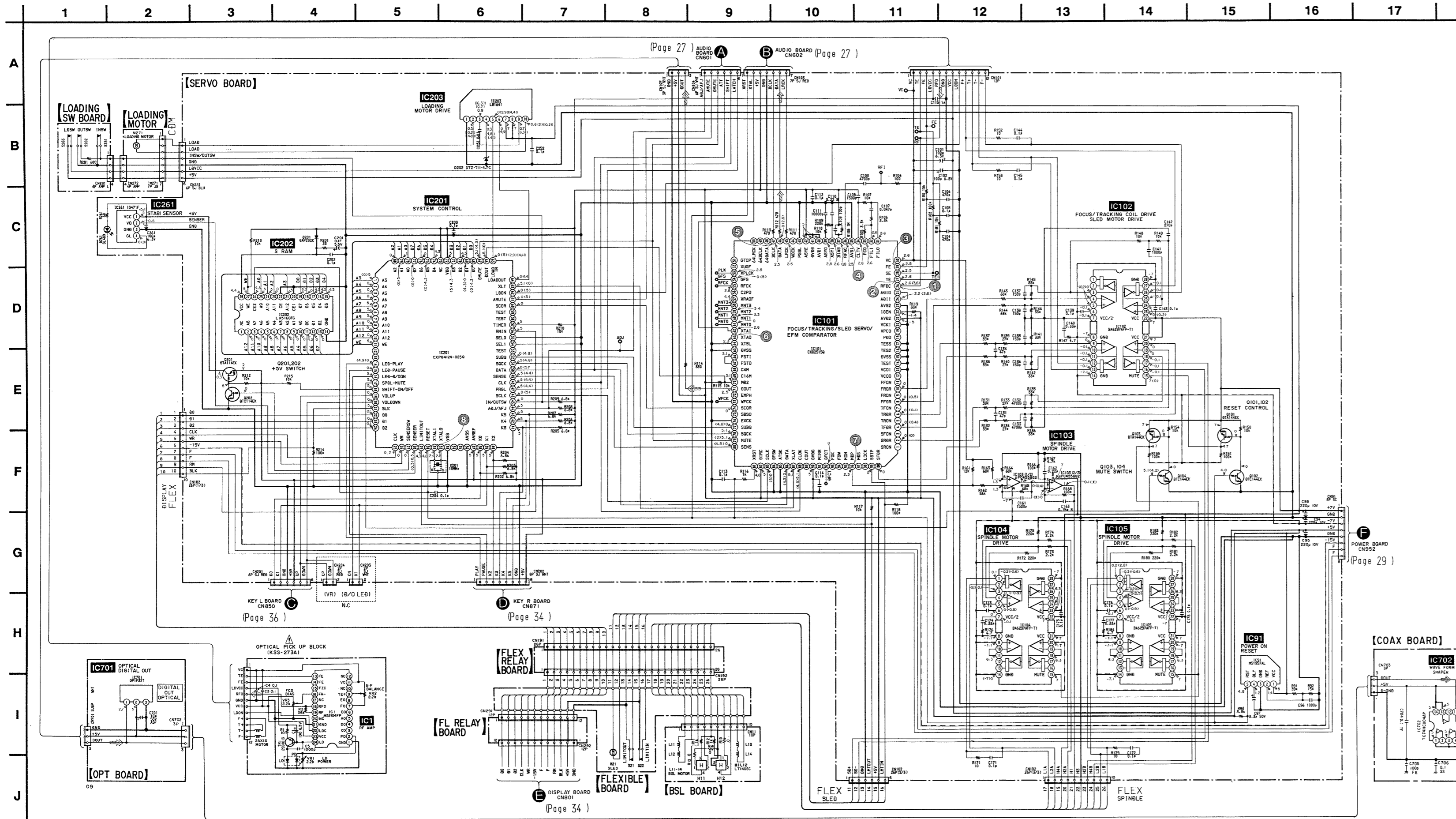

Note:
• All capacitors are in μF unless otherwise noted. $\text{pF}; \mu\text{F}; \mu\text{F}$ 50WV or less are not indicated except for electrolytics and tantalums.
• All resistors are in Ω and 1/4W or less unless otherwise specified.
• Δ : internal component.
• \square : panel designation.

Note: The components identified by mark Δ or dotted line with mark Δ are critical for safety. Replace only with part number specified.

• ——— : B+ Line
• - - - - - : B- Line
• Voltage and waveforms are dc with respect to ground under conditions.
• no mark : STOP
• < > : PLAY
• () : LOAD OUT
• () : LOAD IN
• Voltages are taken with a VOM (Input impedance 10M Ω). Voltage variations may be noted due to normal production tolerances.
• Waveforms are taken with an oscilloscope. Voltage variations may be noted due to normal production tolerances.
• Circled numbers refer to waveforms.
• Signal path.
• \Rightarrow : CD
• \Rightarrow : digital out

• Waveforms

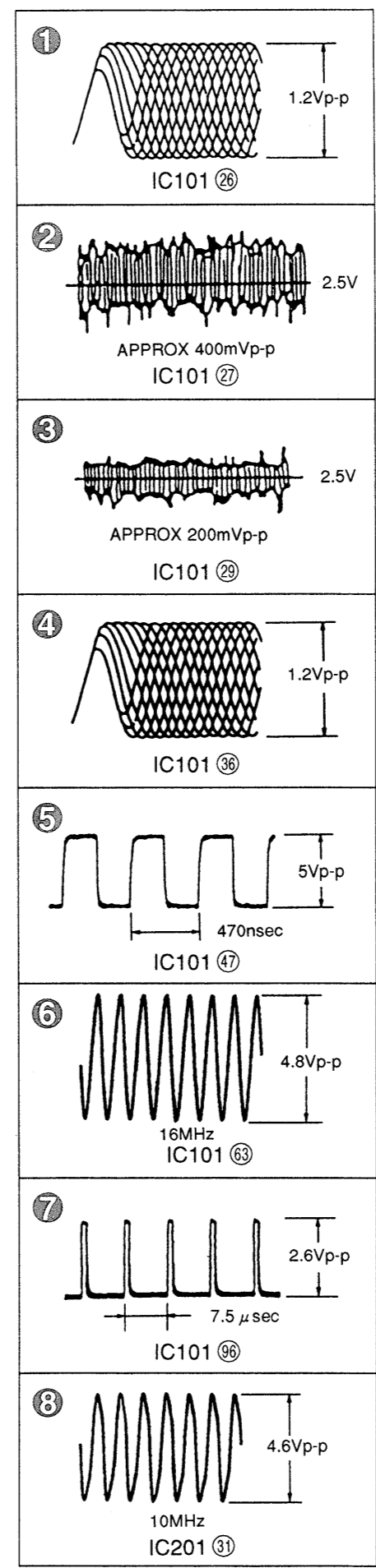

• IC Block Diagrams

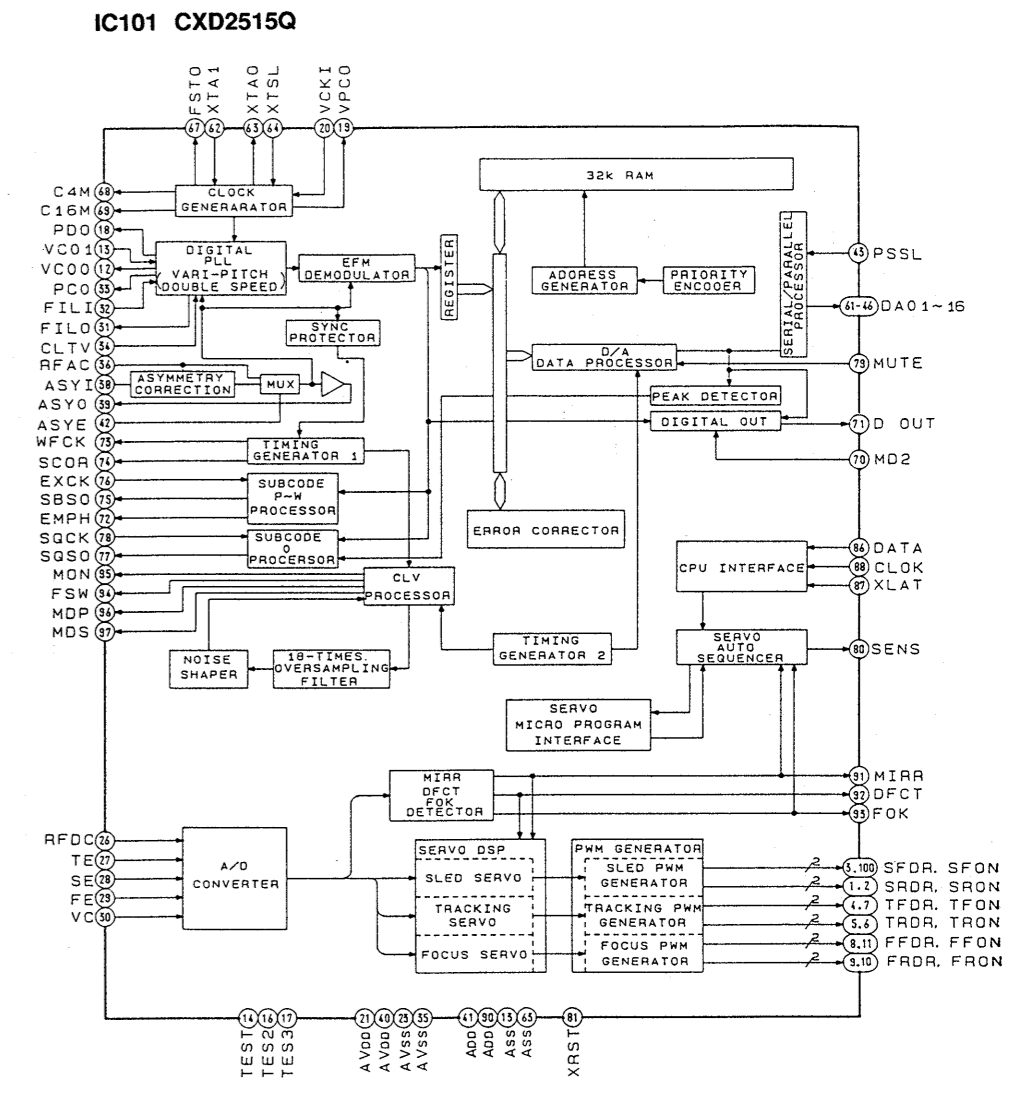

IC203 LB1641

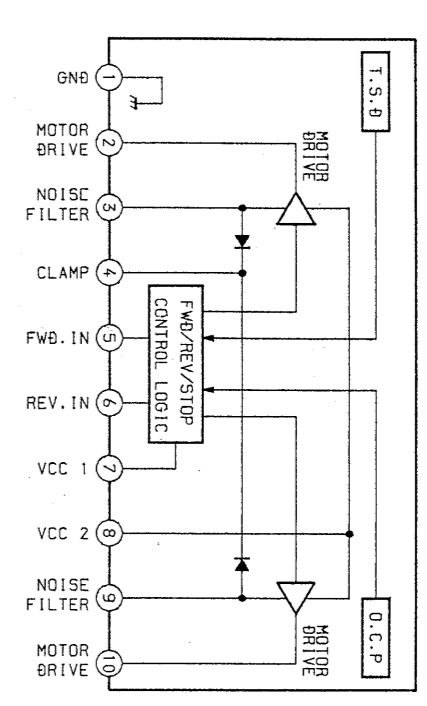

IC91 M51957AL

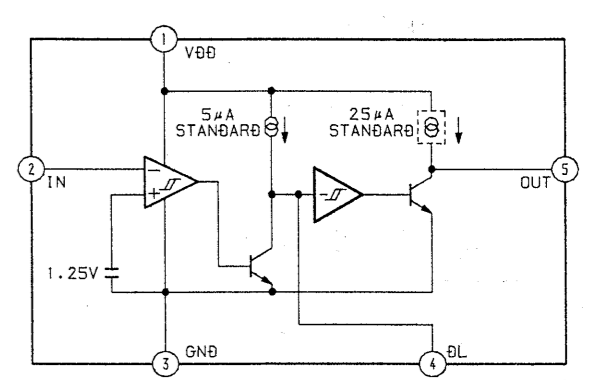

• IC Block Diagrams

IC350 BA6208

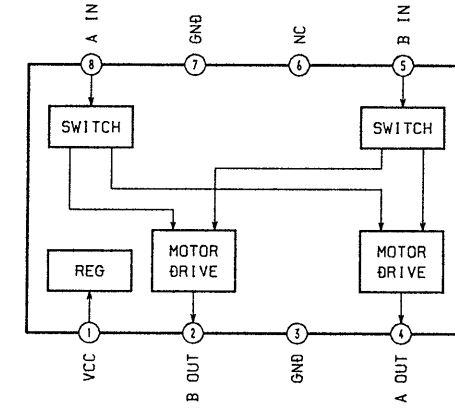

IC400, 500 CXA8042S

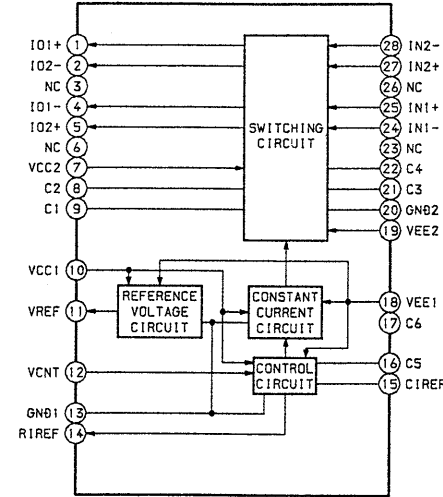

IC601 CXD8504M

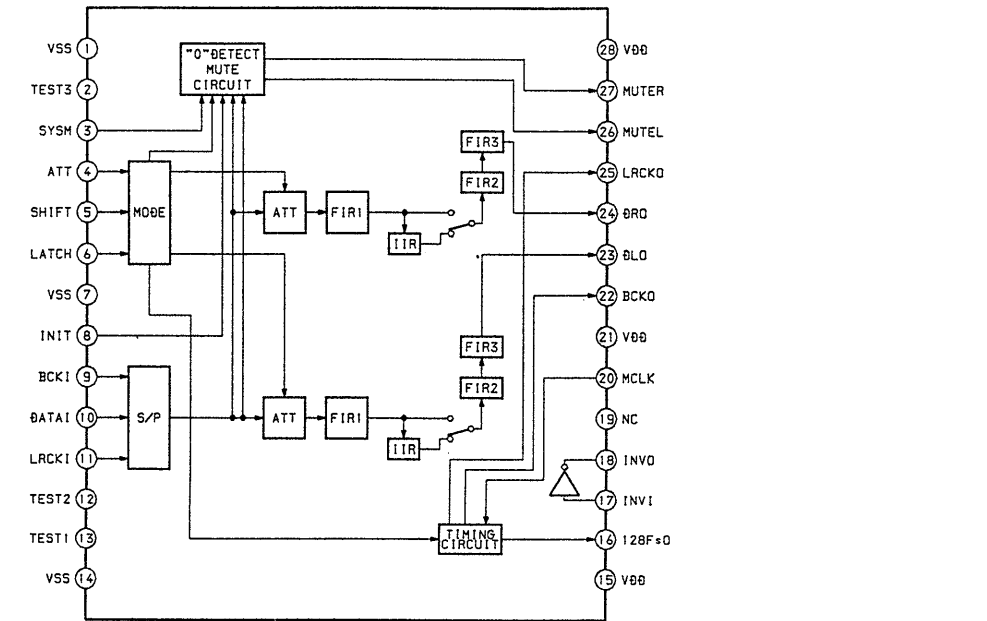

IC603 CXD2562Q

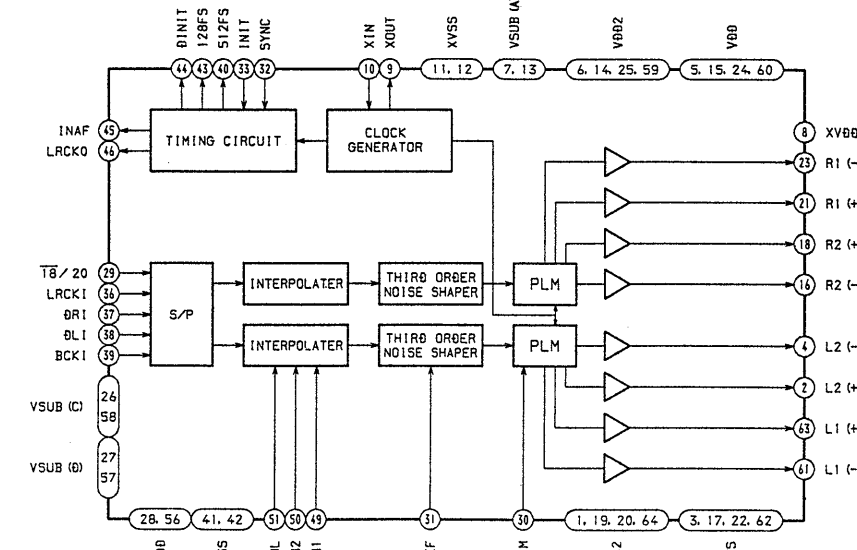

IC604 TCWU04F

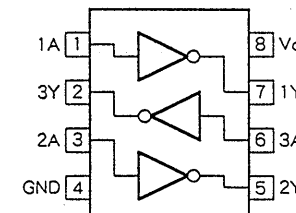

• Semiconductor Location

Ref. No.	Location
D401	I-22
D441	E-20
D471	D-20
D501	G-22
D541	E-17
D601	G-11
D602	F-13
D603	E-13
D625	G-16
D921	D-3
D922	D-3
D923	D-6
D924	D-3
D931	G-3
D932	G-3
D933	G-6
D934	G-7
D951	C-5
D952	B-7
D971	D-3
D972	D-3
D973	C-3
D974	D-3
D975	C-4
D976	D-5
IC350	C-13
IC401	J-19
IC402	I-19
IC403	I-21
IC404	I-15
IC501	F-19
IC502	G-19
IC503	G-21
IC504	F-15
IC601	I-11
IC602	G-11
IC603	H-13
IC604	H-15
IC605	H-17
IC606	F-11
IC607	G-17
IC608	H-17
IC921	E-5
IC951	C-7
IC952	C-7
IC953	C-8
Q405	I-21
Q441	G-12
Q442	E-20
Q443	J-21
Q451	F-13
Q505	G-21
Q541	G-11
Q542	E-17
Q543	F-21
Q551	E-13
Q601	F-13
Q607	E-13
Q921	D-5
Q922	E-7
Q931	F-5
Q932	F-7
Q971	C-4

5-7. PRINTED WIRING BOARD — MAIN SECTION —

- See page 12 for Circuit Boards Location.
- See page 16 for Semiconductor Lead Layouts.

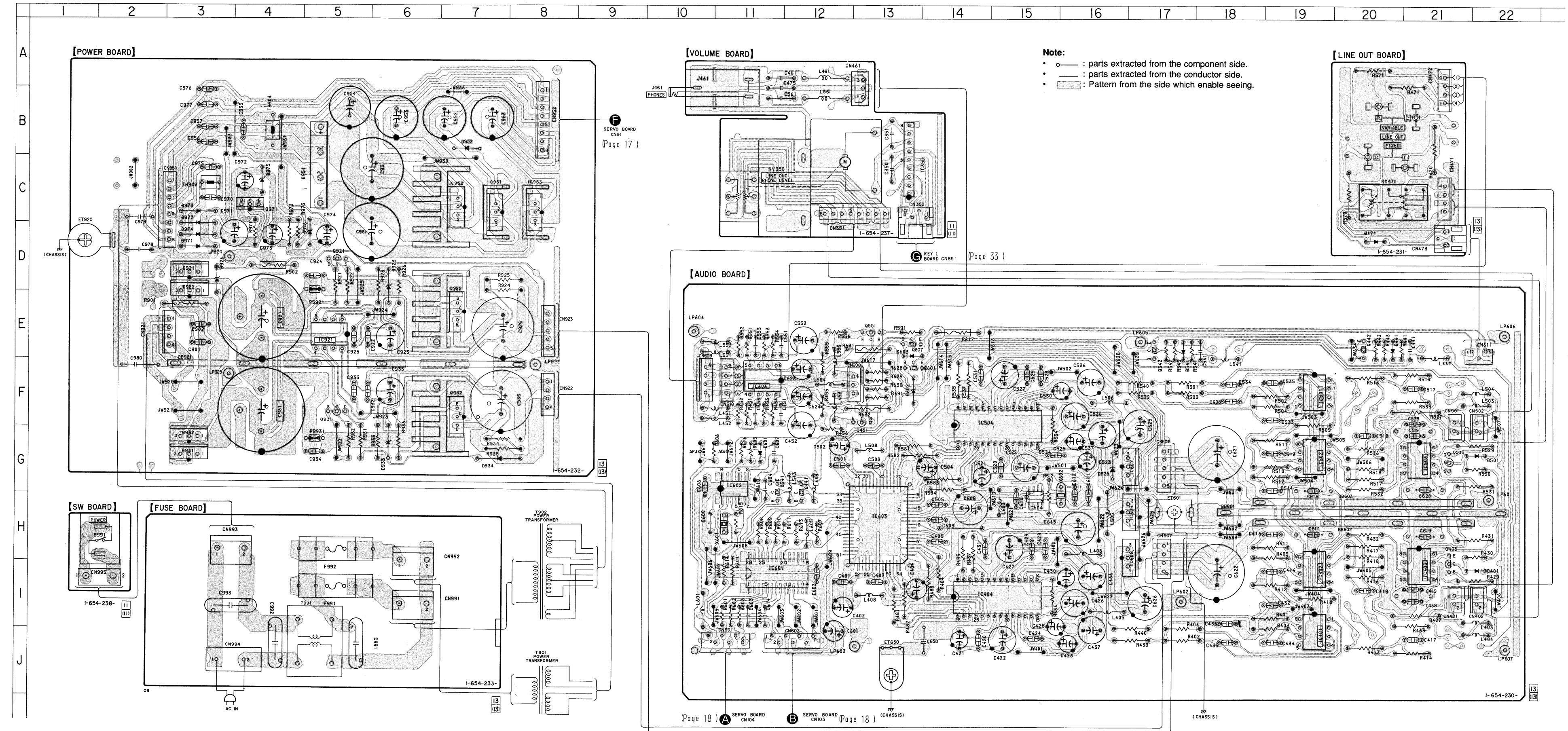

5-8. SCHEMATIC DIAGRAM — MAIN SECTION —

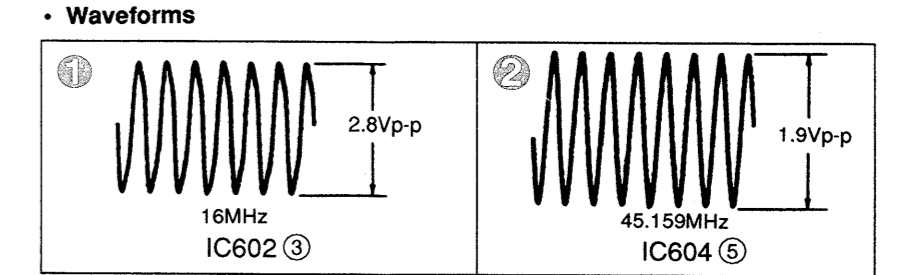
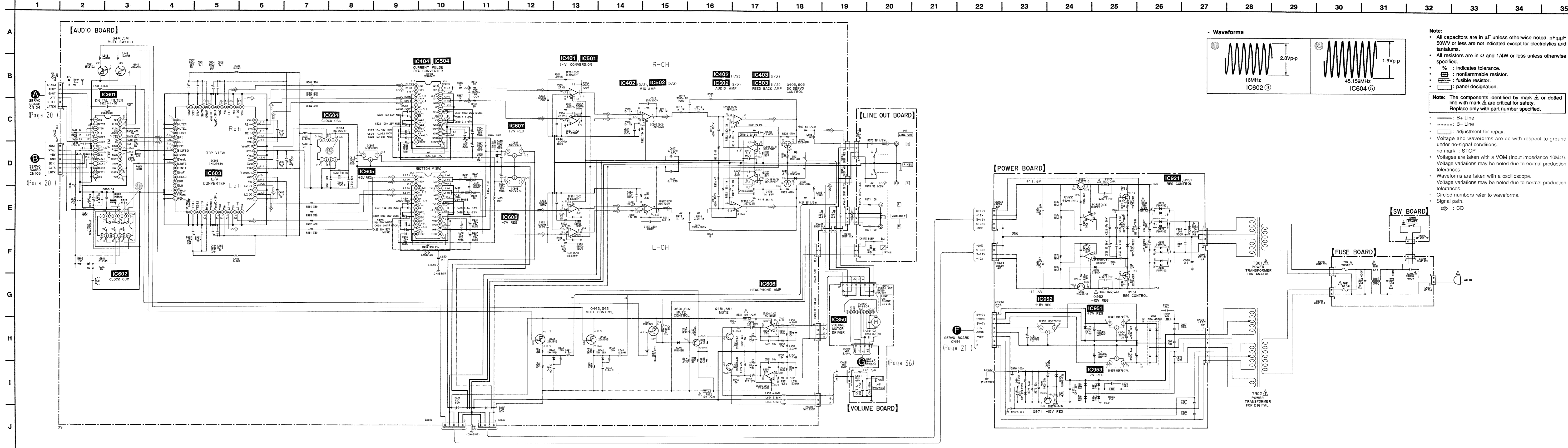

Note:

- All capacitors are in μF unless otherwise noted. pF, μM , 50WV or less are not indicated except for electrolytics and tantalums.
- All resistors are in Ω and 1/4W or less unless otherwise specified.
- % : indicates tolerance.
- \square : nonflammable resistor.
- \square : fusible resistor.
- \square : panel designation.

Note: The components identified by mark Δ or dotted line with mark Δ are critical for safety. Replace only with part number specified.

- \square : B+ Line
- \square : B- Line
- \square : adjustment for repair.
- Voltage and waveforms are dc with respect to ground under no-signal conditions.
- no mark : STOP
- Volts are taken with a VOM (Input impedance 10M Ω). Voltage variations may be noted due to normal production tolerances.
- Waveforms are taken with an oscilloscope. Voltage variations may be noted due to normal production tolerances.
- Circled numbers refer to waveforms.
- Signal path.
- \Rightarrow : CD

5-9. PRINTED WIRING BOARD — PANEL SECTION —

- See page 12 for Circuit Boards Location.
- See page 16 for Semiconductor Lead Layouts.

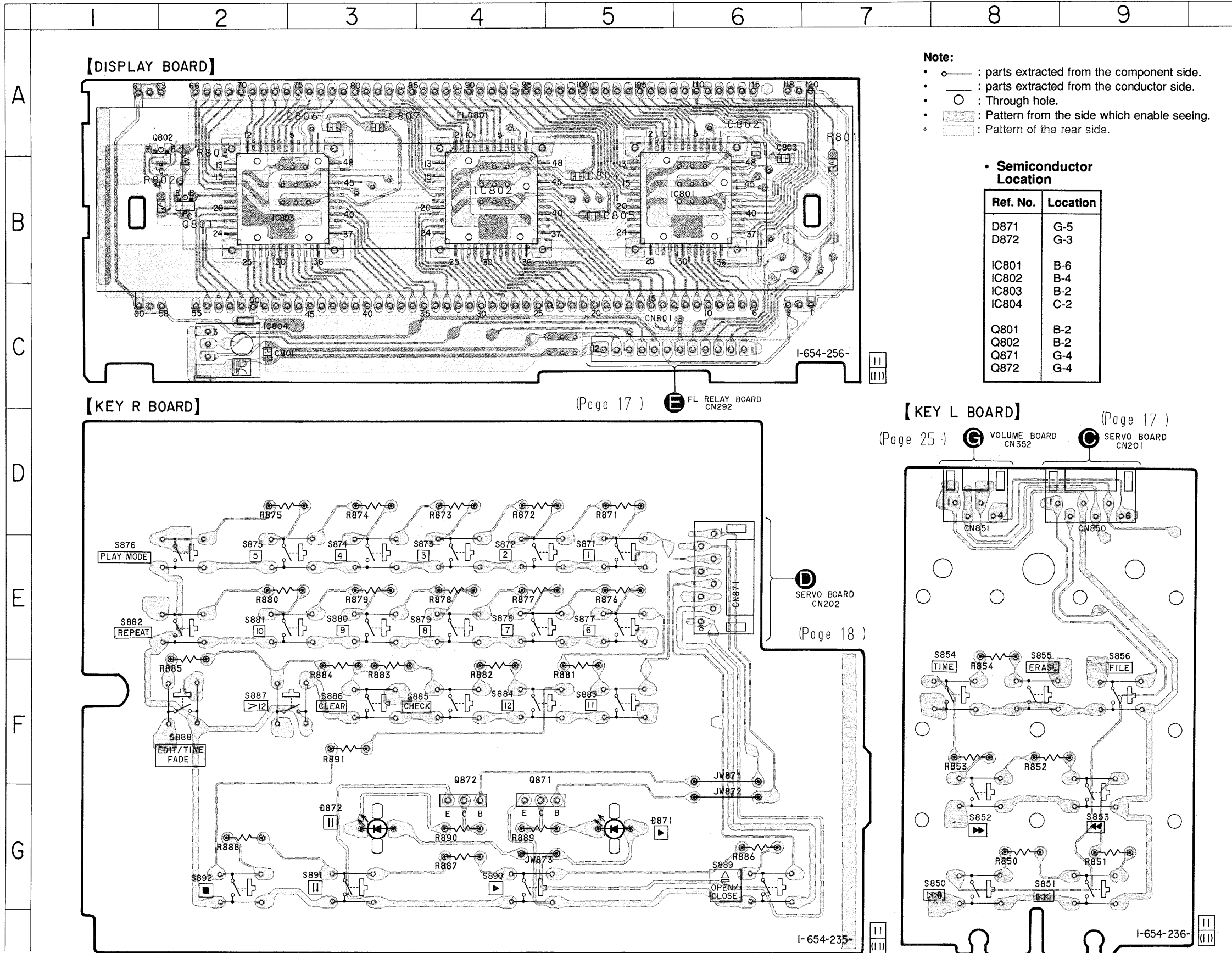

Note:

- —○— : parts extracted from the component side.
- —○— : parts extracted from the conductor side.
- ○ : Through hole.
- [Pattern] : Pattern from the side which enable seeing.
- [Pattern] : Pattern of the rear side.

• Semiconductor Location

Ref. No.	Location
D871	G-5
D872	G-3
IC801	B-6
IC802	B-4
IC803	B-2
IC804	C-2
Q801	B-2
Q802	B-2
Q871	G-4
Q872	G-4

[DISPLAY BOARD]

(Page 17) E FL RELAY BOARD CN292

[KEY R BOARD]

[KEY L BOARD]

(Page 25) G VOLUME BOARD CN352 C SERVO BOARD CN201

D SERVO BOARD CN202 (Page 18)

5-10. SCHEMATIC DIAGRAM — PANEL SECTION —

1 2 3 4 5 6 7 8 9 10 11 12 13 14 15 16 17 18 19 20 21

A

B

C

D

E

F

G

H

I

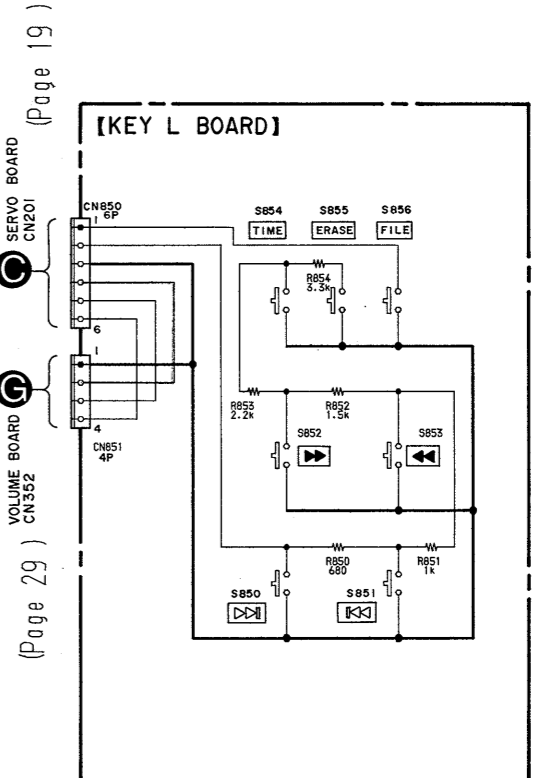
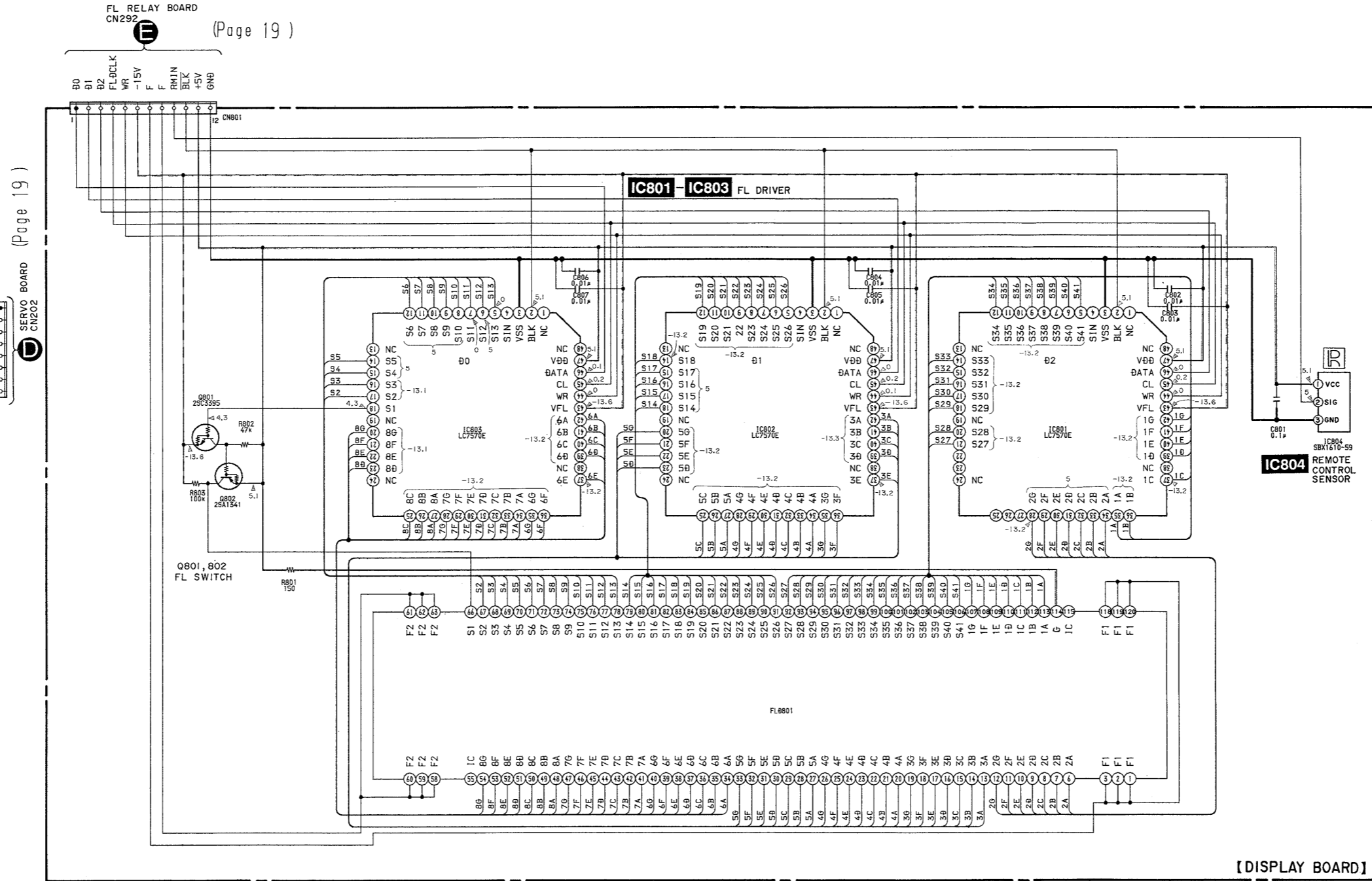
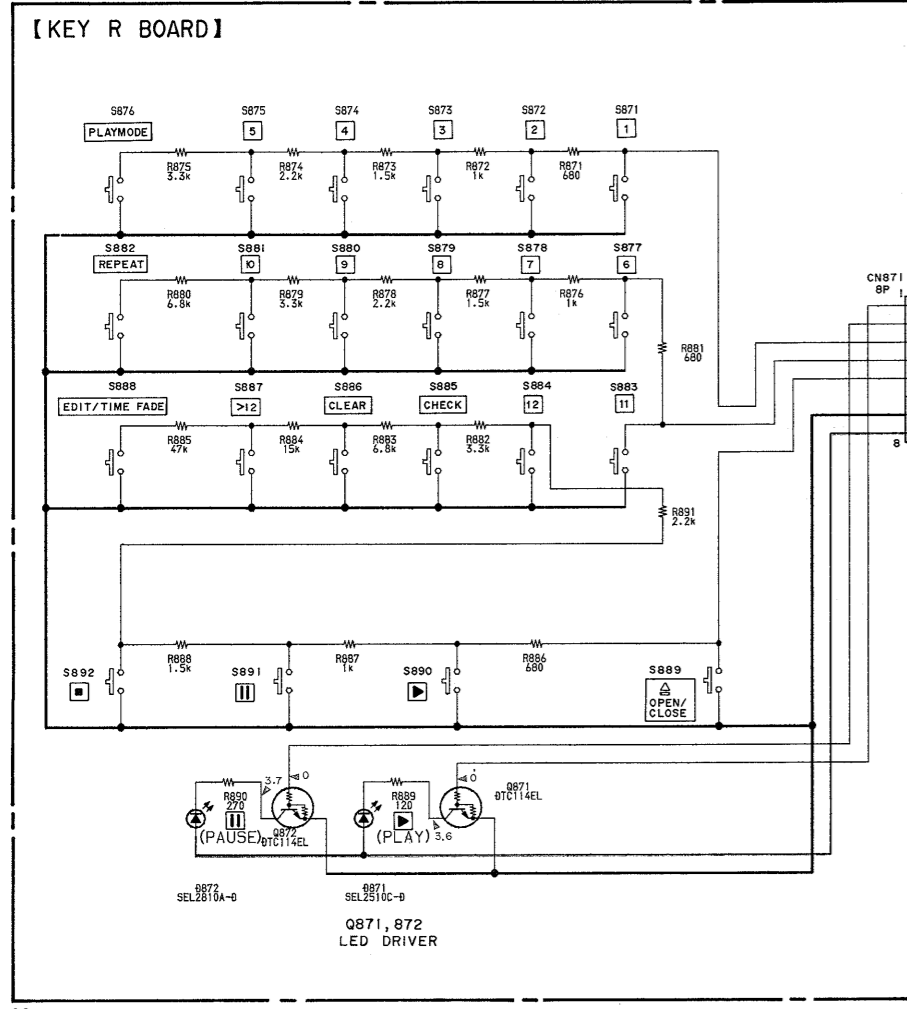

• IC Block Diagram
IC801-803 LC7570E

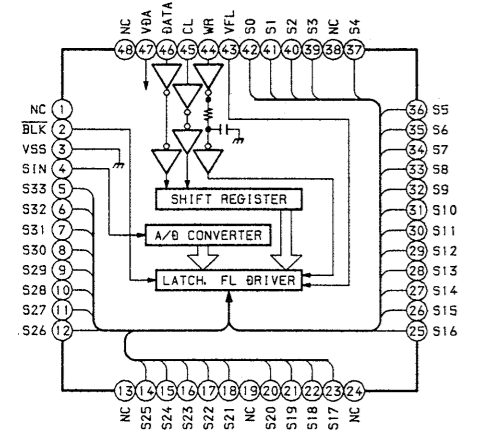

Note:

- All capacitors are in μF unless otherwise noted. $\text{pF}:\mu\text{F}$ 50WV or less are not indicated except for electrolytics and tantalums.
- All resistors are in Ω and 1/4W or less unless otherwise specified.
- : panel designation.
- : B+ Line
- ◻ : B- Line
- Voltage are dc with respect to ground under no-signal conditions.
- no mark : STOP
- Voltages are taken with a VOM (Input impedance 10M Ω). Voltage variations may be noted due to normal production tolerances.

SECTION 6

EXPLODED VIEWS

NOTE:

- Items marked “ * ” are not stocked since they are seldom required for routine service. Some delay should be anticipated when ordering these items.
- Color Indication of Appearance Parts Example:
KNOB, BALANCE (WHITE) . . . (RED)

↑ ↑
Parts color Cabinet's color

- The mechanical parts with no reference number in the exploded views are not supplied.
- Hardware (# mark) list and accessories and packing materials are given in the last of this parts list.
- Abbreviation
G : German model

The components identified by mark or dotted line with mark are critical for safety. Replace only with part number specified.

6-1. LOADING PANEL SECTION

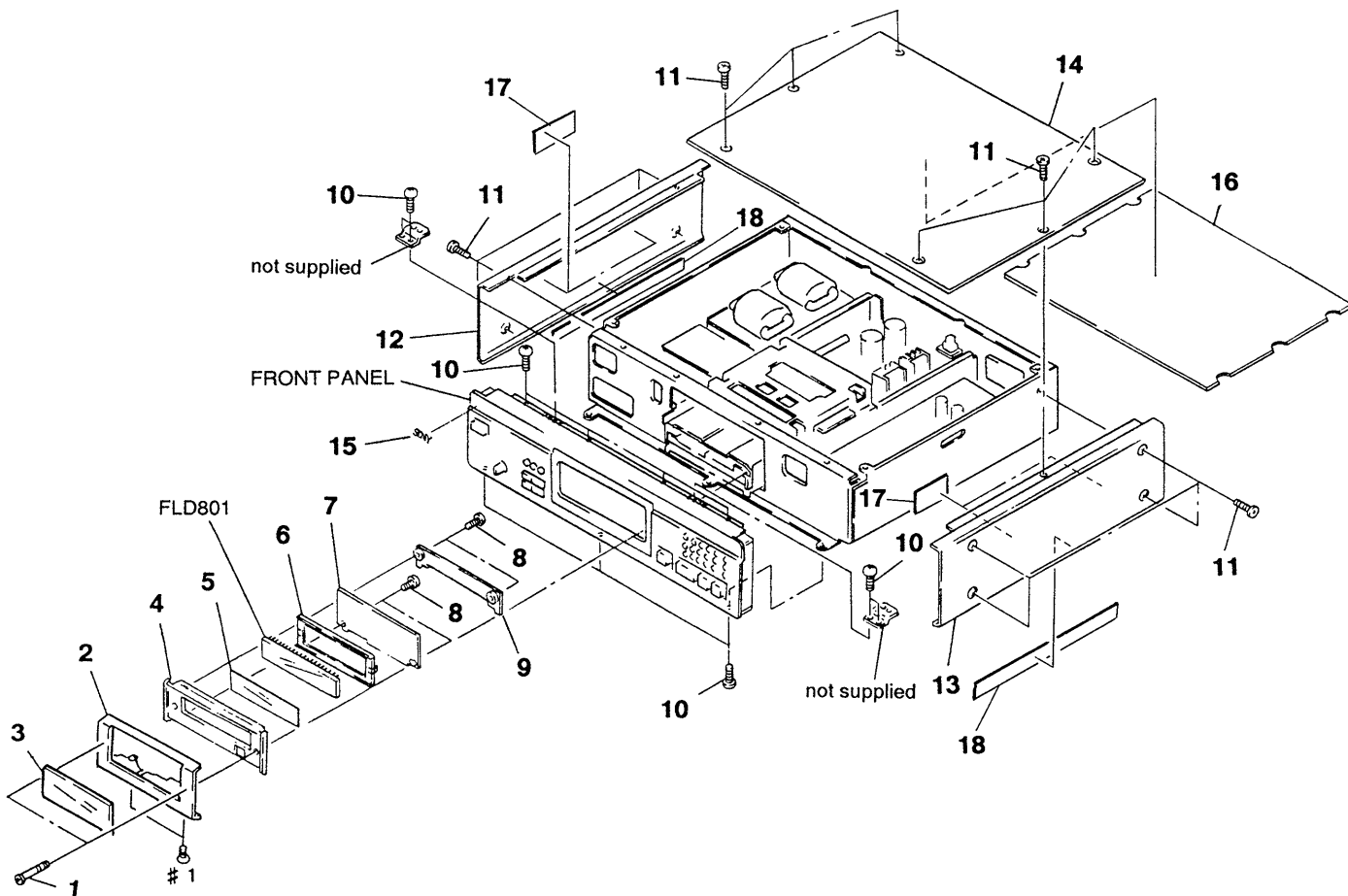

Ref. No.	Part No.	Description	Remark	Ref. No.	Part No.	Description	Remark
1	4-970-998-01	BOLT (3X24), HEXAGON HOLE	(BLACK).. (BLACK)	10	4-929-074-01	SCREW (3X8)	
1	4-970-998-11	BOLT (3X24), HEXAGON HOLE	(SILVER).. (GOLD)	11	4-924-242-11	SCREW (M3X6), FLAT HEAD	(BLACK).. (BLACK)
2	4-969-830-01	PANEL, LOADING (BLACK)		11	4-924-242-61	SCREW (M3X6), FLAT HEAD	(SILVER).. (GOLD)
2	4-969-830-11	PANEL, LOADING (GOLD)		12	4-969-823-01	PLATE (L), SIDE (BLACK)	
3	4-969-832-01	PLATE, INDICATION		12	4-969-823-11	PLATE (L), SIDE (GOLD)	
4	4-969-831-21	BASE, LOADING PANEL (BLACK)		13	4-969-824-01	PLATE (R), SIDE (BLACK)	
4	4-969-831-31	BASE, LOADING PANEL (GOLD)		13	4-969-824-11	PLATE (R), SIDE (GOLD)	
5	4-969-834-01	FILTER		14	4-969-821-01	CASE (TOP PLATE) (BLACK)	
* 6	4-969-510-01	HOLDER (FL)		14	4-969-821-11	CASE (TOP PLATE) (GOLD)	
* 7	1-654-256-11	DISPLAY BOARD		15	4-942-568-01	EMBLEM (NO. 5), SONY (SILVER).. (BLACK)	
8	4-951-620-41	SCREW (2.6), +BVTP (BLACK).. (BLACK)		15	4-942-568-21	EMBLEM (NO. 5), SONY (GOLD).. (GOLD)	
8	4-951-620-51	SCREW (2.6), +BVTP (SILVER).. (GOLD)		* 16	A-4660-735-A	REINFORCEMENT (TOP PLATE) ASSY	
9	4-969-833-21	COVER, LOADING PANEL (BLACK)		17	4-972-438-01	ABSORBENT, VIBRATION	
9	4-969-833-31	COVER, LOADING PANEL (GOLD)		18	4-972-439-01	SPACER (SCREW HEAD)	
				FLD801	1-517-357-11	INDICATOR TUBE, FLUORESCENT	

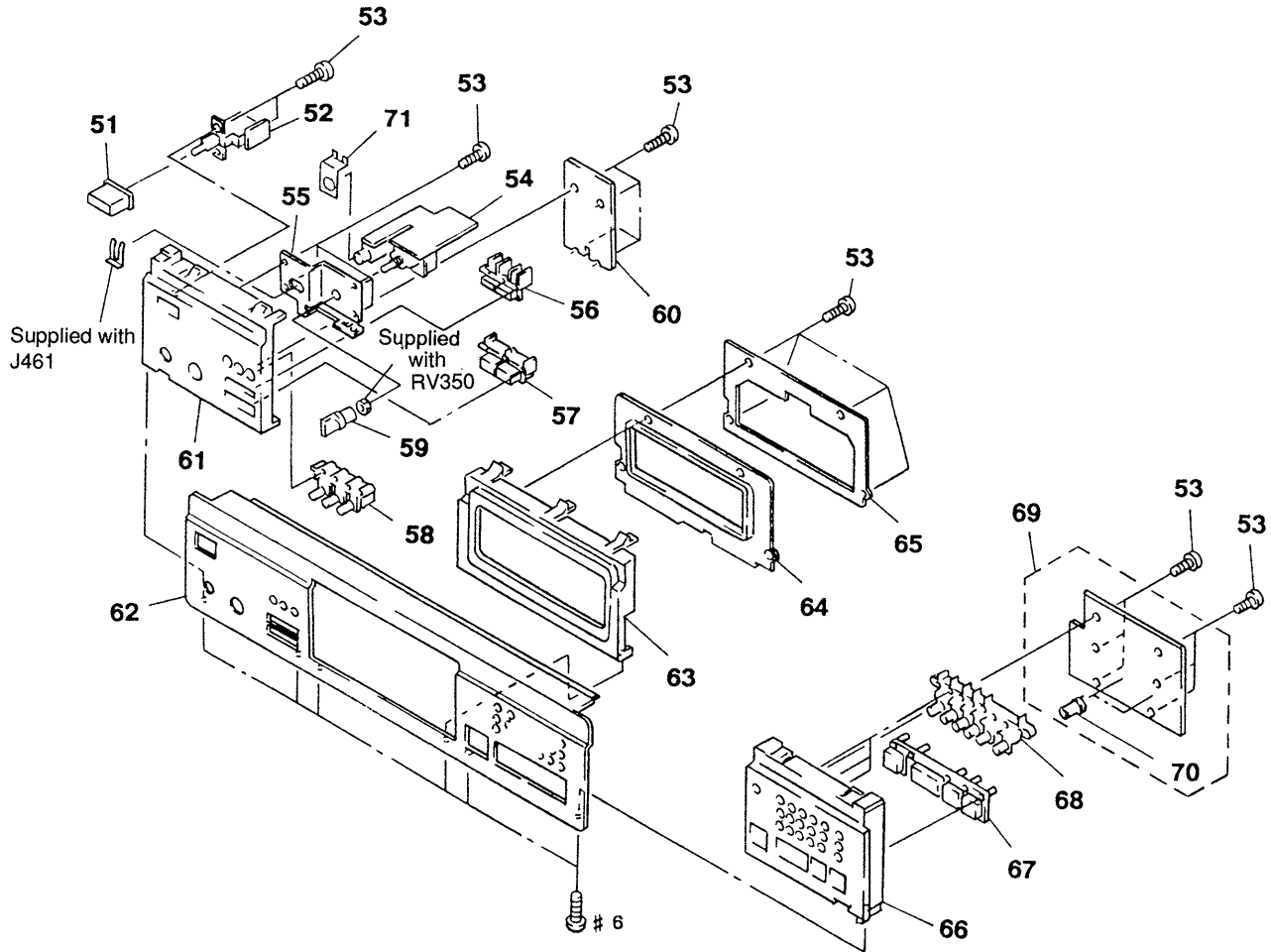

6-2. FRONT PANEL SECTION





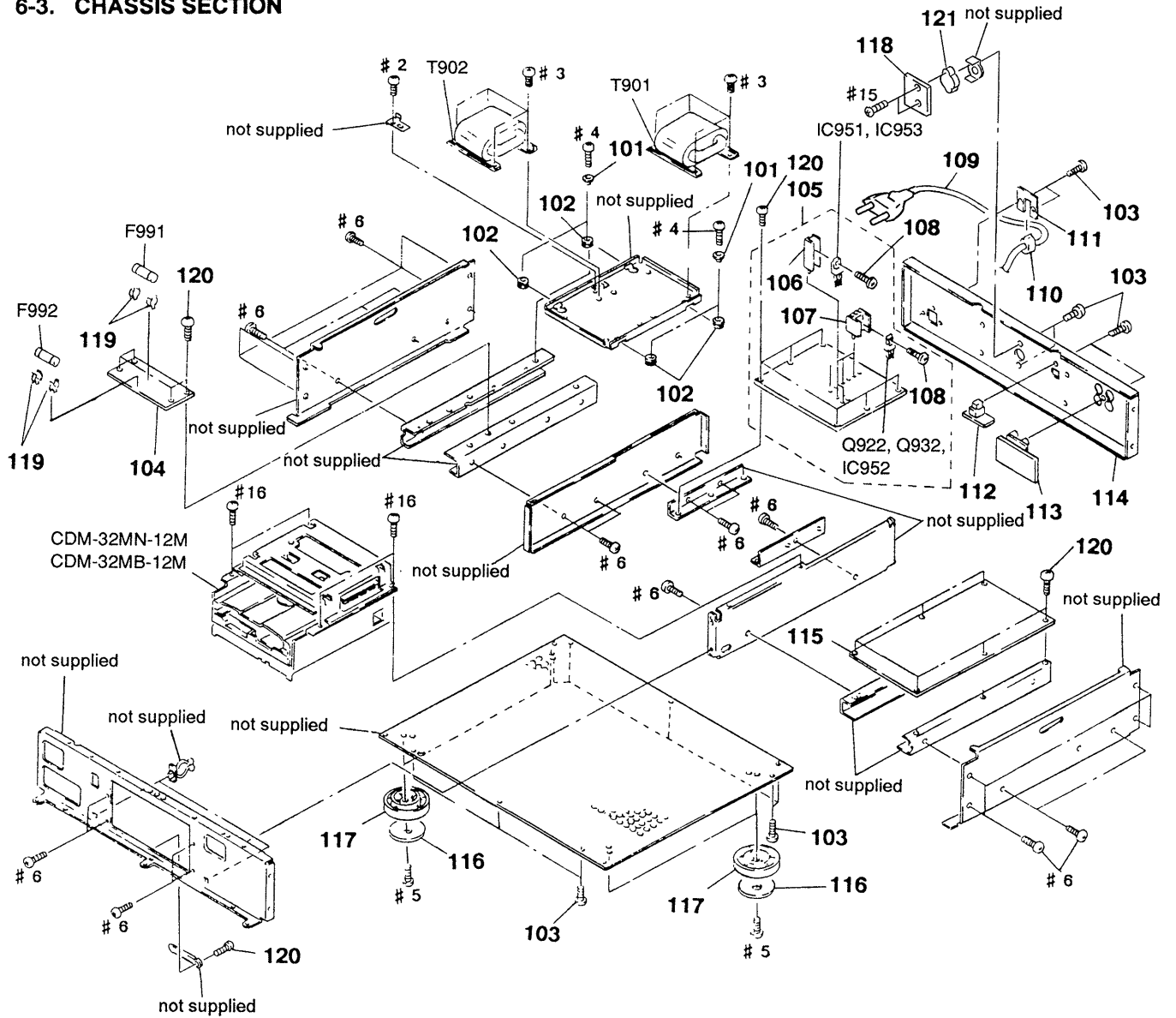

Ref. No.	Part No.	Description	Remark	Ref. No.	Part No.	Description	Remark
51	4-923-520-41	KNOB, POWER (GOLD)		61	4-969-470-11	PANEL (L) (GOLD)	
51	4-923-520-51	KNOB, POWER (BLACK)		62	4-969-816-01	PANEL, FRONT (BLACK)	
* 52	1-654-238-11	SW BOARD		62	4-969-816-11	PANEL, FRONT (GOLD)	
53	4-951-620-01	SCREW (2. 6X8), +BVTP		63	4-969-817-01	PANEL (MD) (BLACK)	
* 54	1-654-237-11	VOLUME BOARD					
* 55	4-969-478-01	BRACKET (HP)		63	4-969-817-11	PANEL (MD) (GOLD)	
56	4-970-528-01	BUTTON (F. R) (BLACK)		64	4-969-818-01	PACKING	
56	4-970-528-11	BUTTON (F. R) (GOLD)		65	4-969-819-11	RETAINER (PACKING)	
57	4-969-562-01	BUTTON (AMS) (BLACK)		66	4-969-471-11	PANEL (R) (BLACK)	
57	4-969-562-11	BUTTON (AMS) (GOLD)		66	4-969-471-21	PANEL (R) (GOLD)	
58	4-970-527-01	BUTTON (TIME) (BLACK)		67	X-4945-276-1	BUTTON (PLAY) ASSY (BLACK)	
58	4-970-527-11	BUTTON (TIME) (GOLD)		67	X-4945-311-1	BUTTON (PLAY) ASSY (GOLD)	
59	4-950-189-01	KNOB (A) (VOL) (BLACK)		68	4-969-475-01	BUTTON (DIRECT) (BLACK)	
59	4-950-189-11	KNOB (A) (VOL) (GOLD)		68	4-969-475-11	BUTTON (DIRECT) (GOLD)	
* 60	1-654-236-11	KEY (L) BOARD		* 69	A-4673-285-A	KEY (R) BOARD, COMPLETE	
61	4-969-470-01	PANEL (L) (BLACK)		* 70	3-362-478-01	HOLDER (T), LED	
				* 71	4-962-201-01	PLATE (HP), GROUND	

6-3. CHASSIS SECTION



The components identified by mark  or dotted line with mark  are critical for safety. Replace only with part number specified.

Ref. No.	Part No.	Description	Remark	Ref. No.	Part No.	Description	Remark
101	4-928-032-01	COLLAR (A)		116	4-970-124-01	CUSHION (F50180S)	
* 102	4-888-798-00	BUSHING, RUBBER		117	4-970-123-01	FOOT (F50180S)	
103	4-929-074-01	SCREW (3X8)		* 118	1-655-466-12	COAX BOARD	
* 104	1-654-233-11	FUSE BOARD		119	1-533-233-11	HOLDER, FUSE	
* 105	A-4673-529-A	POWER BOARD, COMPLETE		120	4-967-961-01	SCREW (3X8) (SPECIAL)	
* 106	4-941-237-01	HEAT SINK		* 121	4-913-152-01	ESCUTCHEON, D/O	
* 107	4-363-146-00	HEAT SINK, V. OUT		 F991	1-532-279-00	FUSE, TIME-LAG (0.5A 250V)	
108	2-259-121-01	SCREW, TR		 F992	1-532-279-00	FUSE, TIME-LAG (0.5A 250V)	
 109	1-558-568-21	CORD, POWER		IC951	8-759-604-86	IC M5F7807L	
* 110	3-703-244-00	BUSHING (2104), CORD		IC952	8-759-231-53	IC TA7805S	
* 111	4-923-873-01	BRACKET, CORD STOPPER		IC953	8-759-604-90	IC M5F7907L	
* 112	1-654-234-11	OPT BOARD		Q922	8-729-107-53	TRANSISTOR 2SC2275A-P	
* 113	1-654-231-11	LINE OUT BOARD		Q932	8-729-141-10	TRANSISTOR 2SA985A-QP	
* 114	4-969-828-11	PANEL, BACK (AEP)		 T901	1-427-816-11	TRANSFORMER, POWER	
* 114	4-969-828-21	PANEL, BACK (G)		 T902	1-427-817-11	TRANSFORMER, POWER	
* 115	A-4673-556-A	AUDIO BOARD, COMPLETE					

6-4. CD MECHANISM SECTION-1
(CDM32MN-12M/CDM32MB-12M)

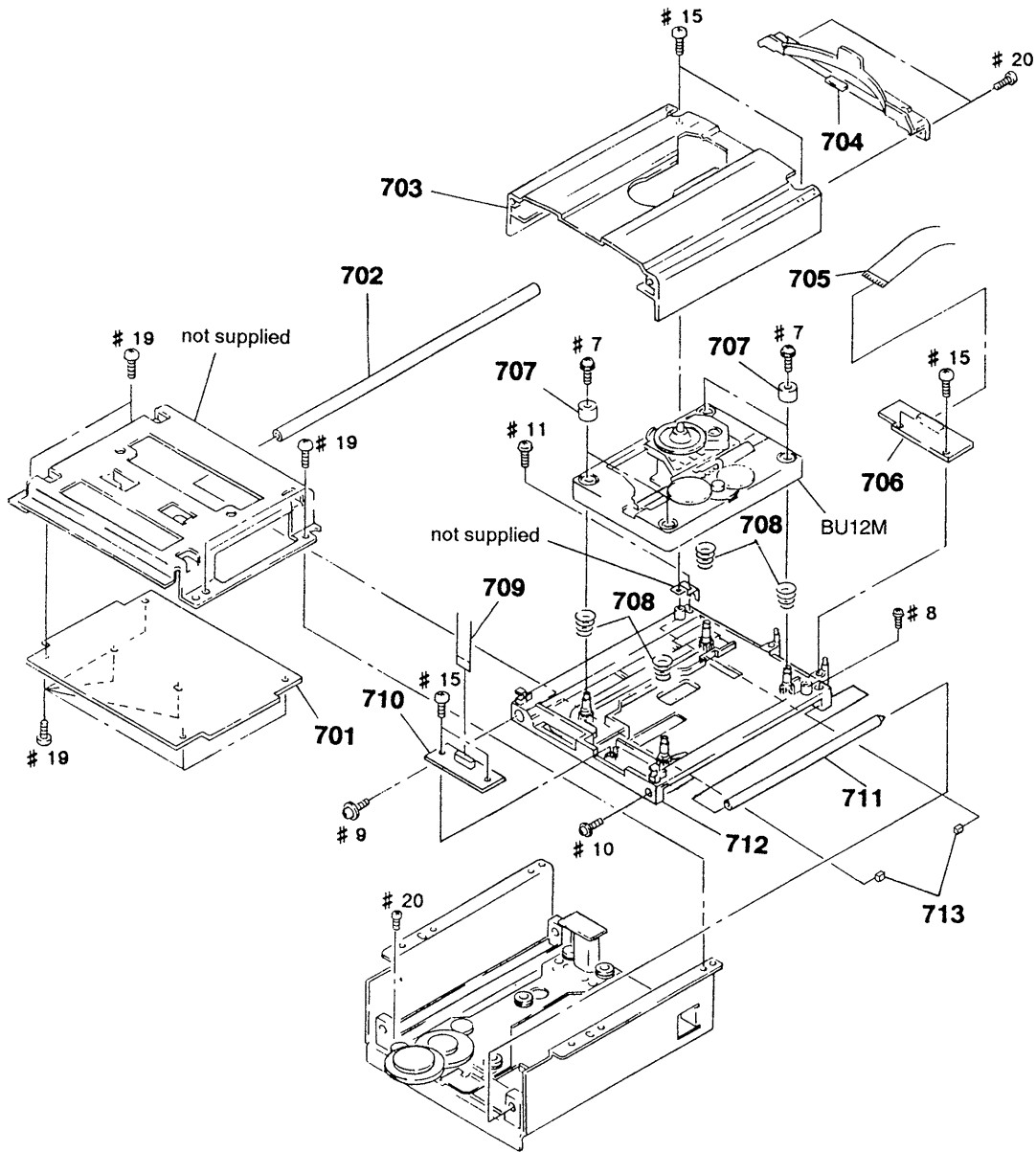

Ref. No.	Part No.	Description	Remark	Ref. No.	Part No.	Description	Remark
* 701	A-4673-224-A	SERVO BOARD, COMPLETE		707	4-927-634-01	HOLDER (SP)	
* 702	4-968-903-01	SHAFT (MAIN)		708	4-948-375-01	SPRING (F), COIL	
703	4-968-907-11	PANEL (DRAWER)		709	1-769-109-11	WIRE (FLAT TYPE) (12 CORE)	
704	4-971-000-21	COVER (CD) (BLACK)		* 710	1-653-906-11	FL RELAY BOARD	
704	4-971-000-31	COVER (CD) (GOLD)		* 711	4-968-904-01	SHAFT (SUB)	
705	1-769-110-11	WIRE (FLAT TYPE) (26 CORE)		* 712	4-968-906-01	HOLDER, BU	
* 706	1-654-005-11	FLEX RELAY BOARD		713	4-925-315-31	DAMPER	

6-5. CD MECHANISM SECTION-2
(CDM32MN-12M/CDM32MB-12M)

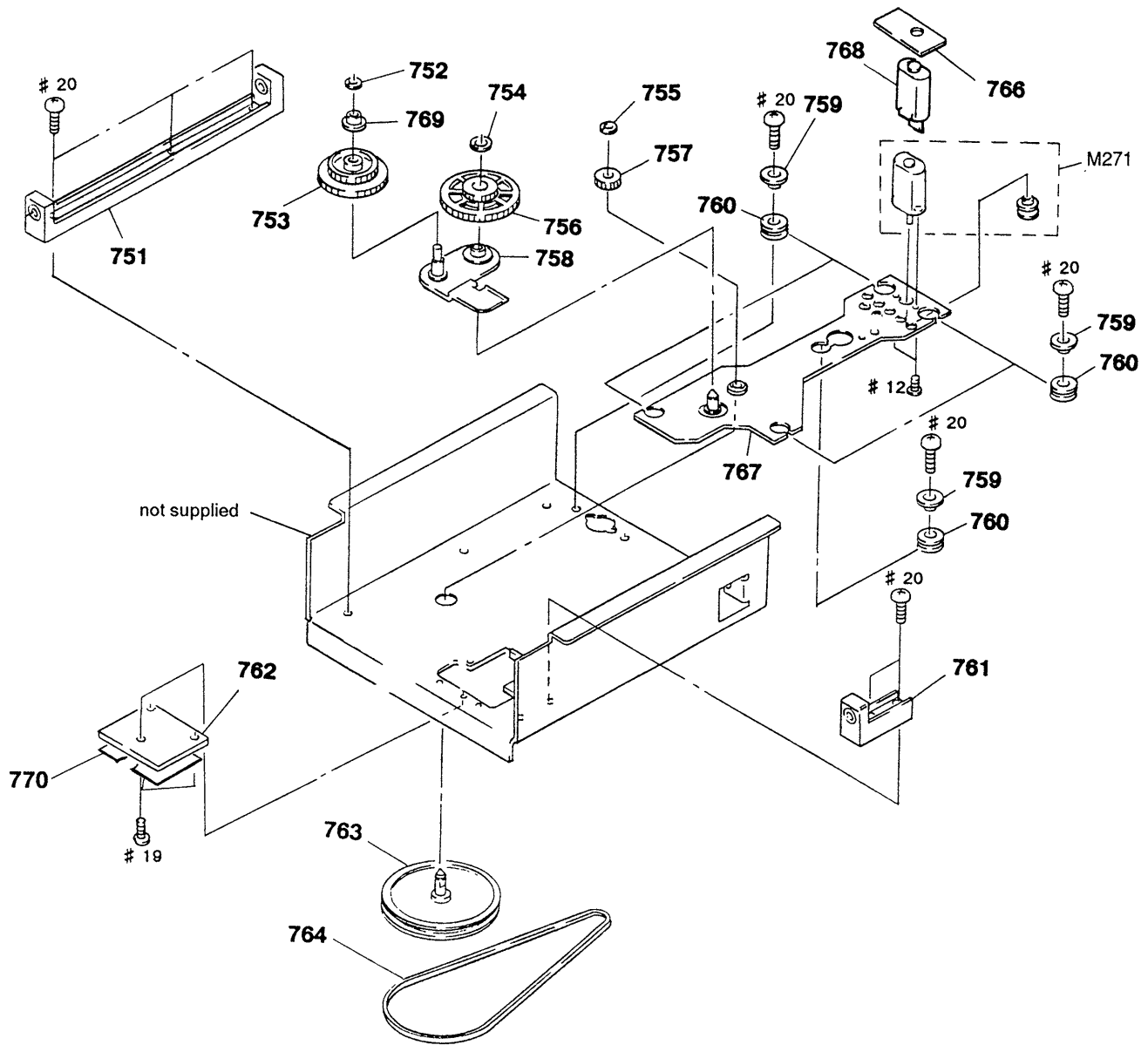

Ref. No.	Part No.	Description	Remark	Ref. No.	Part No.	Description	Remark
* 751	4-968-901-01	BEARING (MAIN)		* 761	4-968-902-01	BEARING (SUB)	
752	3-325-697-31	WASHER		* 762	1-653-905-11	LOADING SW BOARD	
753	4-968-900-01	GEAR (LAST)		763	X-4945-209-1	PULLEY (FIRST) ASSY	
754	3-363-191-01	WASHER (BA)		764	4-968-905-01	BELT (CDM)	
755	4-973-849-01	WASHER		* 766	1-653-907-11	LOADING MOTOR BOARD	
756	4-968-899-01	GEAR (MIDDLE)		767	X-4945-205-1	SHAFT ASSY	
757	4-968-898-01	GEAR (FIRST)		768	4-971-894-01	DAMPER (MOTOR)	
758	X-4945-207-1	BRACKET (LAST) ASSY		* 769	4-970-999-01	ROLLER (J RACK)	
* 759	4-928-026-01	COLLAR (B)		* 770	4-972-921-01	COVER (SW)	
* 760	4-888-798-11	BUSHING, RUBBER		M271	X-4945-565-1	MOTOR ASSY (LOADING)	

6-6. BASE UNIT SECTION (BU-12M)

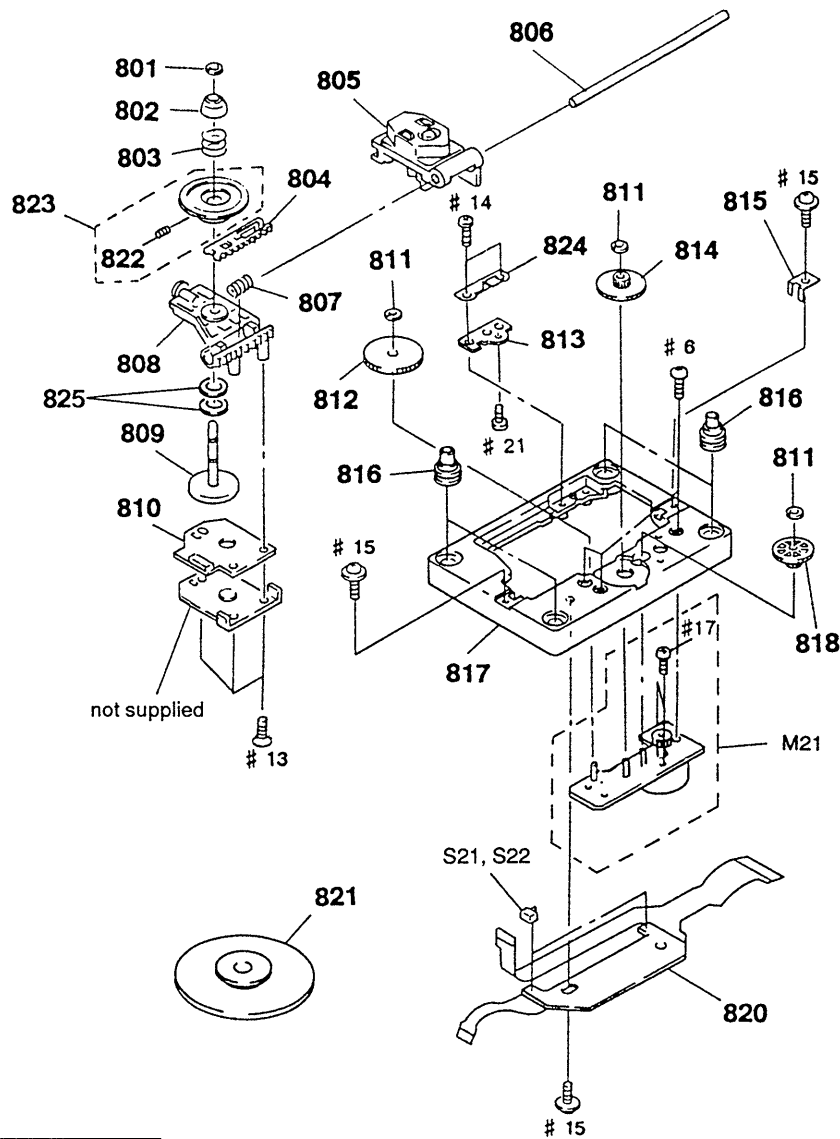

The components identified by mark Δ or dotted line with mark Δ are critical for safety. Replace only with part number specified.

Ref. No.	Part No.	Description	Remark	Ref. No.	Part No.	Description	Remark
801	4-968-871-01	WASHER (SPINDLE)		815	4-968-879-01	SPRING (OP), LEAF	
802	4-968-867-01	CAP, CENTERING		816	4-917-562-11	INSULATOR	
803	4-968-869-01	SPRING (CENTERING), COMPRESSION		* 817	4-968-862-01	BASE, MECHANICAL	
804	4-968-870-01	RACK, SLIDE		818	4-968-864-01	GEAR (B)	
Δ 805	8-848-368-11	OPTICAL PICK-UP BLOCK KSS-273A/J-N		820	1-653-918-11	FLEXIBLE BOARD	
* 806	4-968-944-01	SHAFT, SLED		821	A-4660-688-A	STABILIZER ASSY	
807	4-968-880-01	SPRING (SLED), COMPRESSION		822	4-971-266-01	SCREW (M2.6X4)	
808	X-4945-203-1	BASE ASSY, SLIDE		823	A-4660-814-A	PULLEY ASSY, DISK	
809	X-4945-273-1	ROTOR ASSY		824	4-970-924-01	SPRING (SKEW), LEAF	
810	A-4673-222-A	BSL BOARD, COMPLETE		825	3-701-444-11	WASHER, 6	
811	3-364-731-01	WASHER, POLY-SLIDER		M21	X-4945-920-1	MOTOR ASSY (SLED)	
812	4-968-866-01	GEAR (D)		S21	1-571-958-11	SWITCH, PUSH (1 KEY) (LIMIT OUT)	
813	4-968-916-01	BRACKET (OP BASE)		S22	1-571-958-11	SWITCH, PUSH (1 KEY) (LIMIT IN)	
814	4-968-865-01	GEAR (C)					

SECTION 7 ELECTRICAL PARTS LIST

AUDIO

NOTE:

The components identified by mark Δ or dotted line with mark Δ are critical for safety. Replace only with part number specified.

When indicating parts by reference number, please include the board name.

- Due to standardization, replacements in the parts list may be different from the parts specified in the diagrams or the components used on the set.
- -XX, -X mean standardized parts, so they may have some difference from the original one.
- Items marked "*" are not stocked since they are seldom required for routine service. Some delay should be anticipated when ordering these items.
- RESISTORS
All resistors are in ohms
METAL: Metal-film resistor
METAL OXIDE: Metal Oxide-film resistor
F : nonflammable
- SEMICONDUCTORS
In each case, u: μ , for example:
uA...: μ A..., uPA...: μ PA..., uPB...: μ PB...,
uPC...: μ PC..., uPD...: μ PD...
- CAPACITORS
uF : μ F
- COILS
uH : μ H

Ref. No.	Part No.	Description	Remark	Ref. No.	Part No.	Description	Remark
*	A-4673-556-A	AUDIO BOARD, COMPLETE *****		C501	1-136-165-00	FILM	0.1uF 5% 50V
		< BUS BAR >		C502	1-126-023-11	ELECT	100uF 20% 25V
* BB601	1-691-279-11	BUS BAR 5P		C503	1-136-165-00	FILM	0.1uF 5% 50V
* BB602	1-580-302-11	BAR, BUS 4P		C504	1-126-023-11	ELECT	100uF 20% 25V
* BB603	1-580-302-11	BAR, BUS 4P		C505	1-136-165-00	FILM	0.1uF 5% 50V
* BB921	1-566-940-11	BUS BAR 6P		C513	1-136-810-11	FILM	220PF 5% 100V
		< CAPACITOR >		C514	1-136-810-11	FILM	220PF 5% 100V
C401	1-136-165-00	FILM	0.1uF 5% 50V	C517	1-136-593-11	FILM	0.0033uF 3% 100V
C402	1-126-023-11	ELECT	100uF 20% 25V	C518	1-136-813-11	FILM	680PF 5% 100V
C403	1-136-165-00	FILM	0.1uF 5% 50V	C519	1-104-646-11	CERAMIC	2.2uF 20% 50V
C404	1-126-023-11	ELECT	100uF 20% 25V	C520	1-130-973-00	FILM	0.022uF 5% 100V
C405	1-136-165-00	FILM	0.1uF 5% 50V	C521	1-126-059-11	ELECT	10uF 20% 50V
C413	1-136-810-11	FILM	220PF 5% 100V	C522	1-126-024-11	ELECT	220uF 20% 25V
C414	1-136-810-11	FILM	220PF 5% 100V	C523	1-126-059-11	ELECT	10uF 20% 50V
C417	1-136-593-11	FILM	0.0033uF 3% 100V	C524	1-130-973-00	FILM	0.022uF 5% 100V
C418	1-136-813-11	FILM	680PF 5% 100V	C525	1-126-059-11	ELECT	10uF 20% 50V
C419	1-104-646-11	CERAMIC	2.2uF 20% 50V	C526	1-124-122-11	ELECT	100uF 20% 50V
C420	1-130-973-00	FILM	0.022uF 5% 100V	C527	1-124-122-11	ELECT	100uF 20% 50V
C421	1-126-059-11	ELECT	10uF 20% 50V	C528	1-136-850-11	FILM	0.1uF 5% 63V
C422	1-124-122-11	ELECT	100uF 20% 50V	C529	1-136-850-11	FILM	0.1uF 5% 63V
C423	1-126-059-11	ELECT	10uF 20% 50V	C530	1-126-059-11	ELECT	10uF 20% 50V
C424	1-130-973-00	FILM	0.022uF 5% 100V	C531	1-130-973-00	FILM	0.022uF 3% 100V
C425	1-126-059-11	ELECT	10uF 20% 50V	C532	1-130-969-11	FILM	0.012uF 3% 100V
C426	1-124-122-11	ELECT	100uF 20% 50V	C533	1-130-969-11	FILM	0.012uF 3% 100V
C427	1-124-122-11	ELECT	100uF 20% 50V	C534	1-130-856-00	FILM	0.0068uF 3% 100V
C428	1-136-850-11	FILM	0.1uF 5% 63V	C535	1-130-856-00	FILM	0.0068uF 3% 100V
C429	1-136-850-11	FILM	0.1uF 5% 63V	C536	1-124-122-11	ELECT	100uF 20% 50V
C430	1-126-059-11	ELECT	10uF 20% 50V	C537	1-124-122-11	ELECT	100uF 20% 50V
C431	1-130-973-00	FILM	0.022uF 3% 100V	C538	1-136-850-11	FILM	0.1uF 5% 63V
C432	1-130-969-11	FILM	0.012uF 3% 100V	C541	1-164-159-11	CERAMIC	0.1uF 50V
C433	1-130-969-11	FILM	0.012uF 3% 100V	C551	1-162-199-31	CERAMIC	10PF 5% 50V
C434	1-130-856-00	FILM	0.0068uF 3% 100V	C552	1-124-122-11	ELECT	100uF 20% 50V
C435	1-130-856-00	FILM	0.0068uF 3% 100V	C553	1-162-199-31	CERAMIC	10PF 5% 50V
C436	1-124-122-11	ELECT	100uF 20% 50V	C600	1-164-159-11	CERAMIC	0.1uF 50V
C437	1-124-122-11	ELECT	100uF 20% 50V	C601	1-126-023-11	ELECT	100uF 20% 25V
C438	1-136-850-11	FILM	0.1uF 5% 63V	C602	1-162-806-11	CERAMIC	0.1uF 10% 50V
C441	1-164-159-11	CERAMIC	0.1uF 50V	C603	1-162-290-31	CERAMIC	470PF 10% 50V
C451	1-162-199-31	CERAMIC	10PF 5% 50V	C604	1-162-294-31	CERAMIC	0.001uF 10% 50V
C452	1-126-024-11	ELECT	220uF 20% 25V	C606	1-162-806-11	CERAMIC	0.1uF 10% 50V
C453	1-162-199-31	CERAMIC	10PF 5% 50V	C607	1-164-159-11	CERAMIC	0.1uF 50V
				C608	1-124-918-11	ELECT	47uF 20% 63V
				C609	1-162-806-11	CERAMIC	0.1uF 10% 50V

AUDIO

Ref. No.	Part No.	Description	Remark	Ref. No.	Part No.	Description	Remark
C610	1-162-806-11	CERAMIC	0. 1uF 10% 50V	IC503	8-759-053-07	IC OP-27GP	
C611	1-102-947-00	CERAMIC	10PF 5% 50V	IC504	8-759-293-17	IC CXA8042S	
C612	1-102-947-00	CERAMIC	10PF 5% 50V	IC601	8-759-287-69	IC CXD8504M	
C613	1-126-365-51	ELECT	100uF 20% 63V	IC602	8-759-233-64	IC TC74HCU04AF	
C614	1-162-294-31	CERAMIC	0. 001uF 10% 50V				
C617	1-136-960-11	FILM	0. 1uF 10% 160V	IC603	8-759-044-10	IC CXD2562Q	
C618	1-136-960-11	FILM	0. 1uF 10% 160V	IC604	8-759-242-70	IC TC7WU04F	
C619	1-136-960-11	FILM	0. 1uF 10% 160V	IC605	8-759-231-53	IC TA7805S	
C620	1-136-960-11	FILM	0. 1uF 10% 160V	IC606	8-759-981-85	IC RC4556D	
C621	1-124-919-11	ELECT	220uF 20% 63V	IC607	8-759-604-86	IC M5F7807L	
C622	1-124-919-11	ELECT	220uF 20% 63V	IC608	8-759-604-90	IC M5F7907L	
C623	1-126-023-11	ELECT	100uF 20% 25V			< COIL >	
C624	1-126-023-11	ELECT	100uF 20% 25V	L403	1-414-514-21	INDUCTOR	10uH
C625	1-126-365-51	ELECT	100uF 20% 63V	L404	1-414-512-21	INDUCTOR	6. 8uH
C626	1-126-365-51	ELECT	100uF 20% 63V	L405	1-412-473-21	INDUCTOR	0uH
C650	1-164-159-11	CERAMIC	0. 1uF 50V	L406	1-412-473-21	INDUCTOR	0uH
		< CONNECTOR >		L408	1-414-510-21	INDUCTOR	3. 3uH
CN401	1-564-505-11	PLUG, CONNECTOR 2P		L441	1-414-512-21	INDUCTOR	6. 8uH
* CN402	1-564-505-11	PLUG, CONNECTOR 2P		L443	1-414-512-21	INDUCTOR	6. 8uH
* CN501	1-564-505-11	PLUG, CONNECTOR 2P		L451	1-414-512-21	INDUCTOR	6. 8uH
* CN502	1-564-505-11	PLUG, CONNECTOR 2P		L452	1-414-509-21	INDUCTOR	2. 2uH
* CN601	1-691-462-11	PIN, CONNECTOR (PC BOARD) 6P		L453	1-414-512-21	INDUCTOR	6. 8uH
CN602	1-691-463-31	PIN, CONNECTOR (PC BOARD) 7P		L503	1-414-514-21	INDUCTOR	10uH
CN608	1-564-506-11	PLUG, CONNECTOR 3P		L504	1-414-512-21	INDUCTOR	6. 8uH
* CN609	1-564-507-11	PLUG, CONNECTOR 4P		L505	1-412-473-21	INDUCTOR	0uH
* CN610	1-564-507-11	PLUG, CONNECTOR 4P		L506	1-412-473-21	INDUCTOR	0uH
CN611	1-691-459-21	PIN, CONNECTOR (PC BOARD) 3P		L508	1-414-510-21	INDUCTOR	3. 3uH
		< DIODE >		L541	1-414-512-21	INDUCTOR	6. 8uH
D401	8-719-987-63	DIODE 1N4148M		L543	1-414-512-21	INDUCTOR	6. 8uH
D441	8-719-987-63	DIODE 1N4148M		L551	1-414-512-21	INDUCTOR	6. 8uH
D501	8-719-987-63	DIODE 1N4148M		L552	1-414-509-21	INDUCTOR	2. 2uH
D541	8-719-987-63	DIODE 1N4148M		L553	1-414-512-21	INDUCTOR	6. 8uH
D601	8-719-987-63	DIODE 1N4148M		L601	1-414-512-21	INDUCTOR	6. 8uH
D602	8-719-115-65	DIODE RD6. 8JS-T2B1		L603	1-414-510-21	INDUCTOR	3. 3uH
D603	8-719-987-63	DIODE 1N4148M		L604	1-414-512-21	INDUCTOR	6. 8uH
D625	8-719-210-21	DIODE 11EQS04		L605	1-414-510-21	INDUCTOR	3. 3uH
		< TERMINAL >				< TRANSISTOR >	
ET601	4-924-264-01	TERMINAL, MOUNT		Q405	8-729-224-63	TRANSISTOR	2SK246-BL
ET650	1-537-770-21	TERMINAL, GROUND		Q441	8-729-900-80	TRANSISTOR	DTC114ES
		< IC >		Q442	8-729-900-65	TRANSISTOR	DTA144ES
IC401	8-759-602-83	IC M5238P		Q451	8-729-231-55	TRANSISTOR	2SC2878-AB
IC402	8-759-971-80	IC AD712JN		Q505	8-729-224-63	TRANSISTOR	2SK246-BL
IC403	8-759-053-07	IC OP-27GP		Q541	8-729-900-80	TRANSISTOR	DTC114ES
IC404	8-759-293-17	IC CXA8042S		Q542	8-729-900-65	TRANSISTOR	DTA144ES
IC501	8-759-602-83	IC M5238P		Q551	8-729-231-55	TRANSISTOR	2SC2878-AB
IC502	8-759-971-80	IC AD712JN		Q601	8-729-900-65	TRANSISTOR	DTA144ES
				Q607	8-729-900-65	TRANSISTOR	DTA144ES

Ref. No.	Part No.	Description				Remark	Ref. No.	Part No.	Description				Remark
< RESISTOR >							R517	1-249-461-11	CARBON	18K	5%	1/4W	
R401	1-249-909-11	CARBON	270	1%	1/4W		R518	1-249-930-11	CARBON	2K	1%	1/4W	
R402	1-249-909-11	CARBON	270	1%	1/4W		R527	1-249-637-11	CARBON	33	5%	1/2W	
R403	1-249-885-11	CARBON	27	1%	1/4W		R529	1-249-616-11	CARBON	470K	5%	1/4W	
R404	1-249-885-11	CARBON	27	1%	1/4W		R530	1-259-500-11	CARBON	1M	5%	1/6W	
R409	1-249-947-11	CARBON	10K	1%	1/4W		R531	1-249-616-11	CARBON	470K	5%	1/4W	
R410	1-249-947-11	CARBON	10K	1%	1/4W		R532	1-249-977-11	CARBON	180K	1%	1/4W	
R411	1-249-950-11	CARBON	13K	1%	1/4W		R533	1-249-506-11	CARBON	12	5%	1/4W	
R412	1-249-950-11	CARBON	13K	1%	1/4W		R534	1-247-706-11	CARBON	330	5%	1/4W	F
R413	1-249-923-11	CARBON	1K	1%	1/4W		R535	1-249-504-11	CARBON	10	5%	1/4W	
R414	1-249-931-11	CARBON	2.2K	1%	1/4W		R537	1-249-504-11	CARBON	10	5%	1/4W	
R416	1-249-520-11	CARBON	47	5%	1/4W		R539	1-249-504-11	CARBON	10	5%	1/4W	
R417	1-249-461-11	CARBON	18K	5%	1/4W		R540	1-249-504-11	CARBON	10	5%	1/4W	
R418	1-249-930-11	CARBON	2K	1%	1/4W		R541	1-259-476-11	CARBON	100K	5%	1/6W	
R427	1-249-637-11	CARBON	33	5%	1/2W		R542	1-259-452-11	CARBON	10K	5%	1/6W	
R429	1-249-616-11	CARBON	470K	5%	1/4W		R543	1-259-472-11	CARBON	68K	5%	1/6W	
R430	1-259-500-11	CARBON	1M	5%	1/6W		R551	1-259-444-11	CARBON	4.7K	5%	1/6W	
R431	1-249-616-11	CARBON	470K	5%	1/4W		R552	1-259-476-11	CARBON	100K	5%	1/6W	
R432	1-249-977-11	CARBON	180K	1%	1/4W		R553	1-259-456-11	CARBON	15K	5%	1/6W	
R433	1-249-506-11	CARBON	12	5%	1/4W		R554	1-259-464-11	CARBON	33K	5%	1/6W	
R434	1-247-706-11	CARBON	330	5%	1/4W	F	R555	1-259-468-11	CARBON	47K	5%	1/6W	
R435	1-249-504-11	CARBON	10	5%	1/4W		R556	1-259-398-11	CARBON	56	5%	1/6W	
R437	1-249-504-11	CARBON	10	5%	1/4W		R581	1-259-416-11	CARBON	330	5%	1/6W	
R439	1-249-504-11	CARBON	10	5%	1/4W		R582	1-259-416-11	CARBON	330	5%	1/6W	
R440	1-249-504-11	CARBON	10	5%	1/4W		R583	1-259-416-11	CARBON	330	5%	1/6W	
R441	1-259-476-11	CARBON	100K	5%	1/6W		R584	1-259-416-11	CARBON	330	5%	1/6W	
R442	1-259-452-11	CARBON	10K	5%	1/6W		R591	1-259-440-11	CARBON	3.3K	5%	1/6W	
R443	1-259-472-11	CARBON	68K	5%	1/6W		R601	1-259-428-11	CARBON	1K	5%	1/6W	
R451	1-259-444-11	CARBON	4.7K	5%	1/6W		R602	1-259-428-11	CARBON	1K	5%	1/6W	
R452	1-259-476-11	CARBON	100K	5%	1/6W		R603	1-259-428-11	CARBON	1K	5%	1/6W	
R453	1-259-456-11	CARBON	15K	5%	1/6W		R604	1-259-428-11	CARBON	1K	5%	1/6W	
R454	1-259-464-11	CARBON	33K	5%	1/6W		R605	1-259-452-11	CARBON	10K	5%	1/6W	
R455	1-259-468-11	CARBON	47K	5%	1/6W		R606	1-259-424-11	CARBON	680	5%	1/6W	
R456	1-259-398-11	CARBON	56	5%	1/6W		R607	1-259-424-11	CARBON	680	5%	1/6W	
R481	1-259-416-11	CARBON	330	5%	1/6W		R608	1-259-420-11	CARBON	470	5%	1/6W	
R482	1-259-416-11	CARBON	330	5%	1/6W		R609	1-259-420-11	CARBON	470	5%	1/6W	
R483	1-259-416-11	CARBON	330	5%	1/6W		R610	1-259-420-11	CARBON	470	5%	1/6W	
R484	1-259-416-11	CARBON	330	5%	1/6W		R611	1-259-420-11	CARBON	470	5%	1/6W	
R491	1-259-440-11	CARBON	3.3K	5%	1/6W		R612	1-249-947-11	CARBON	10K	1%	1/4W	
R501	1-249-909-11	CARBON	270	1%	1/4W		R613	1-259-424-11	CARBON	680	5%	1/6W	
R502	1-249-909-11	CARBON	270	1%	1/4W		R614	1-259-416-11	CARBON	330	5%	1/6W	
R503	1-249-885-11	CARBON	27	1%	1/4W		R615	1-259-448-11	CARBON	6.8K	5%	1/6W	
R504	1-249-885-11	CARBON	27	1%	1/4W		R616	1-259-500-11	CARBON	1M	5%	1/6W	
R509	1-249-947-11	CARBON	10K	1%	1/4W		△R617	1-212-887-00	FUSIBLE	180	5%	1/4W	F
R510	1-249-947-11	CARBON	10K	1%	1/4W		R628	1-259-484-11	CARBON	220K	5%	1/6W	
R511	1-249-950-11	CARBON	13K	1%	1/4W		R629	1-259-460-11	CARBON	22K	5%	1/6W	
R512	1-249-950-11	CARBON	13K	1%	1/4W		R630	1-259-476-11	CARBON	100K	5%	1/6W	
R513	1-249-923-11	CARBON	1K	1%	1/4W		△R631	1-219-022-11	FUSIBLE	100	5%	1/2W	
R514	1-249-931-11	CARBON	2.2K	1%	1/4W		△R632	1-219-022-11	FUSIBLE	100	5%	1/2W	
R516	1-249-520-11	CARBON	47	5%	1/4W								

The components identified by mark △ or dotted line with mark △ are critical for safety. Replace only with part number specified.

AUDIO **BSL** **COAX** **DISPLAY** **FL RELAY** **FLEX RELAY**

Ref.No.	Part No.	Description	Remark
		< VIBRATOR >	
X601	1-577-685-11	FILTER, CRYSTAL (16MHz)	
X602	1-579-161-11	VIBRATOR, CRYSTAL (45MHz)	

	A-4673-222-A	BSL BOARD, COMPLETE	

		< HALL ELEMENT >	
H11	8-719-987-62	DIODE LT140SC-TE84L	
H12	8-719-987-62	DIODE LT140SC-TE84L	
		< RESISTOR >	
R11	1-216-049-91	METAL GLAZE 1K 5% 1/10W	
R12	1-216-049-91	METAL GLAZE 1K 5% 1/10W	
R13	1-216-295-91	CONDUCTOR, CHIP (2012)	
R14	1-216-295-91	CONDUCTOR, CHIP (2012)	
R15	1-216-295-91	CONDUCTOR, CHIP (2012)	

*	1-655-466-12	COAX BOARD	

		< CAPACITOR >	
C702	1-104-645-11	CERAMIC 1uF 20% 50V	
C703	1-162-806-11	CERAMIC 0.1uF 10% 50V	
C704	1-136-165-00	FILM 0.1uF 5% 50V	
C705	1-107-611-11	MICA 100PF 5% 500V	
C706	1-162-806-11	CERAMIC 0.1uF 10% 50V	
		< CONNECTOR >	
CN703	1-580-771-31	PIN, CONNECTOR (PC BOARD) 3P	
		< IC >	
IC702	8-759-917-18	IC SN74HCU04AN	
		< JACK >	
J701	1-507-567-71	JACK, PIN 1P (DIGITAL OUT COAXIAL)	
		< RESISTOR >	
R701	1-259-401-11	CARBON 75 5% 1/6W	
		< TRANSFORMER >	
T701	1-459-795-11	COIL (WITH CORE)	

Ref.No.	Part No.	Description	Remark
*	1-654-256-11	DISPLAY BOARD	

*	4-969-510-01	HOLDER (FL)	
		< CAPACITOR >	
C801	1-163-038-91	CERAMIC CHIP 0.1uF 25V	
C802	1-163-031-11	CERAMIC CHIP 0.01uF 50V	
C803	1-163-031-11	CERAMIC CHIP 0.01uF 50V	
C804	1-163-031-11	CERAMIC CHIP 0.01uF 50V	
C805	1-163-031-11	CERAMIC CHIP 0.01uF 50V	
C806	1-163-031-11	CERAMIC CHIP 0.01uF 50V	
C807	1-163-031-11	CERAMIC CHIP 0.01uF 50V	
		< FLUORESCENT INDICATOR >	
FLD801	1-517-357-11	INDICATOR TUBE, FLUORESCENT	
		< IC >	
IC801	8-759-324-36	IC LC7570E	
IC802	8-759-324-36	IC LC7570E	
IC803	8-759-324-36	IC LC7570E	
IC804	8-749-923-80	IC GP1U90XB	
		< TRANSISTOR >	
Q801	8-729-805-45	TRANSISTOR 2SC3395	
Q802	8-729-901-06	TRANSISTOR DTA144EK	
		< RESISTOR >	
R801	1-216-029-00	METAL CHIP 150 5% 1/10W	
R802	1-216-089-00	METAL CHIP 47K 5% 1/10W	
R803	1-216-097-00	METAL CHIP 100K 5% 1/10W	

*	1-653-906-11	FL RELAY BOARD	

		< CONNECTOR >	
CN291	1-568-794-11	SOCKET, CONNECTOR 12P	
* CN292	1-568-950-11	PIN, CONNECTOR 12P	

*	1-654-005-11	FLEX RELAY BOARD	

		< CONNECTOR >	
CN191	1-580-473-11	SOCKET, CONNECTOR 26P	

FLEXIBLE

FUSE

KEY (L)

KEY (R)

Ref. No.	Part No.	Description	Remark	Ref. No.	Part No.	Description	Remark
	1-653-918-11	FLEXIBLE BOARD ***** < SWITCH >		S853	1-554-303-21	SWITCH, TACTILE (◀◀)	
				S854	1-554-303-21	SWITCH, TACTILE (TIME)	
S21	1-571-958-11	SWITCH, PUSH (1 KEY) (LIMIT OUT)		S855	1-554-303-21	SWITCH, TACTILE (ERASE)	
S22	1-571-958-11	SWITCH, PUSH (1 KEY) (LIMIT IN)		S856	1-554-303-21	SWITCH, TACTILE (FILE)	
*****				*****			
*	1-654-233-11	FUSE BOARD *****		*	A-4673-285-A	KEY (R) BOARD, COMPLETE *****	
	1-533-233-11	HOLDER, FUSE < CAPACITOR >		*	3-362-478-01	HOLDER (T), LED < CONNECTOR >	
△C991	1-162-599-12	CERAMIC 0.0047uF 20% 400V		CN871	1-580-775-11	PIN, CONNECTOR (PC BOARD) 8P < DIODE >	
△C992	1-162-599-12	CERAMIC 0.0047uF 20% 400V		D871	8-719-303-02	DIODE SEL2510C-D	
△C993	1-161-744-00	CERAMIC 0.01uF 400V		D872	8-719-301-52	LED SEL2810A-C	
		< CONNECTOR >				< TRANSISTOR >	
* CN991	1-564-321-21	PIN, CONNECTOR 2P		Q871	8-729-900-45	TRANSISTOR DTC114EF	
CN992	1-770-128-11	PIN, CONNECTOR 2P		Q872	8-729-900-45	TRANSISTOR DTC114EF	
CN993	1-564-321-00	PIN, CONNECTOR 2P				< RESISTOR >	
CN994	1-580-230-11	PIN, CONNECTOR (PC BOARD) 3P		R871	1-249-415-11	CARBON 680 5% 1/4W F	
		< FUSE >		R872	1-249-417-11	CARBON 1K 5% 1/4W F	
△F991	1-532-279-00	FUSE, TIME-LAG (0.5A)		R873	1-249-419-11	CARBON 1.5K 5% 1/4W F	
△F992	1-532-279-00	FUSE, TIME-LAG (0.5A)		R874	1-249-421-11	CARBON 2.2K 5% 1/4W F	
		< TRANSFORMER >		R875	1-249-423-11	CARBON 3.3K 5% 1/4W F	
△T991	1-421-915-11	COIL, LINE FILTER		R876	1-249-417-11	CARBON 1K 5% 1/4W F	
*****				R877	1-249-419-11	CARBON 1.5K 5% 1/4W F	
*	1-654-236-11	KEY (L) BOARD *****		R878	1-249-421-11	CARBON 2.2K 5% 1/4W F	
		< CONNECTOR >		R879	1-249-423-11	CARBON 3.3K 5% 1/4W F	
CN850	1-580-774-11	PIN, CONNECTOR (PC BOARD) 6P		R880	1-249-427-11	CARBON 6.8K 5% 1/4W F	
* CN851	1-580-772-11	PIN, CONNECTOR (PC BOARD) 4P		R881	1-249-415-11	CARBON 680 5% 1/4W F	
		< RESISTOR >		R882	1-249-423-11	CARBON 3.3K 5% 1/4W F	
R850	1-249-415-11	CARBON 680 5% 1/4W F		R883	1-249-427-11	CARBON 6.8K 5% 1/4W F	
R851	1-249-417-11	CARBON 1K 5% 1/4W F		R884	1-249-431-11	CARBON 15K 5% 1/4W	
R852	1-249-419-11	CARBON 1.5K 5% 1/4W F		R885	1-249-437-11	CARBON 47K 5% 1/4W	
R853	1-249-421-11	CARBON 2.2K 5% 1/4W F		R886	1-249-415-11	CARBON 680 5% 1/4W F	
R854	1-249-423-11	CARBON 3.3K 5% 1/4W F		R887	1-249-417-11	CARBON 1K 5% 1/4W F	
		< SWITCH >		R888	1-249-419-11	CARBON 1.5K 5% 1/4W F	
S850	1-554-303-21	SWITCH, TACTILE (▷▷◁)		R889	1-249-406-11	CARBON 120 5% 1/4W F	
S851	1-554-303-21	SWITCH, TACTILE (◁◁▷)		R890	1-249-410-11	CARBON 270 5% 1/4W F	
S852	1-554-303-21	SWITCH, TACTILE (▶▶)		R891	1-249-421-11	CARBON 2.2K 5% 1/4W F	
						< SWITCH >	
				S871	1-554-303-21	SWITCH, TACTILE (1)	
				S872	1-554-303-21	SWITCH, TACTILE (2)	
				S873	1-554-303-21	SWITCH, TACTILE (3)	

The components identified by mark △ or dotted line with mark △ are critical for safety. Replace only with part number specified.

KEY (R) LINE OUT LOADING MOTOR

LOADING SW OPT POWER

Ref. No.	Part No.	Description	Remark
S874	1-554-303-21	SWITCH, TACTILE (4)	
S875	1-554-303-21	SWITCH, TACTILE (5)	
S876	1-554-303-21	SWITCH, TACTILE (PLAY MODE)	
S877	1-554-303-21	SWITCH, TACTILE (6)	
S878	1-554-303-21	SWITCH, TACTILE (7)	
S879	1-554-303-21	SWITCH, TACTILE (8)	
S880	1-554-303-21	SWITCH, TACTILE (9)	
S881	1-554-303-21	SWITCH, TACTILE (10)	
S882	1-554-303-21	SWITCH, TACTILE (REPEAT)	
S883	1-554-303-21	SWITCH, TACTILE (11)	
S884	1-554-303-21	SWITCH, TACTILE (12)	
S885	1-554-303-21	SWITCH, TACTILE (CHECK)	
S886	1-554-303-21	SWITCH, TACTILE (CLEAR)	
S887	1-554-303-21	SWITCH, TACTILE (>12)	
S888	1-554-303-21	SWITCH, TACTILE (EDIT/TIME FADE)	
S889	1-554-303-21	SWITCH, TACTILE (△ OPEN/CLOSE)	
S890	1-554-303-21	SWITCH, TACTILE (▶)	
S891	1-554-303-21	SWITCH, TACTILE (■)	
S892	1-554-303-21	SWITCH, TACTILE (■)	

*	1-654-231-11	LINE OUT BOARD	

		< CONNECTOR >	
* CN471	1-564-519-11	PLUG, CONNECTOR 4P	
* CN472	1-564-519-11	PLUG, CONNECTOR 4P	
CN473	1-580-771-31	PIN, CONNECTOR (PC BOARD) 3P	
		< DIODE >	
D471	8-719-987-63	DIODE IN4148M	
		< JACK >	
J471	1-568-101-11	JACK, PIN 4P (LINE OUT)	
		< RESISTOR >	
R470	1-249-637-11	CARBON 33 5% 1/2W	
R471	1-247-700-11	CARBON 100 5% 1/4W F	
R570	1-249-637-11	CARBON 33 5% 1/2W	
R571	1-247-700-11	CARBON 100 5% 1/4W F	
		< RELAY >	
RY471	1-515-804-11	RELAY	

Ref. No.	Part No.	Description	Remark
*	1-653-907-11	LOADING MOTOR BOARD	

		< CONNECTOR >	
CN272	1-506-469-11	PIN, CONNECTOR 4P	

*	1-653-905-11	LOADING SW BOARD	

		< CONNECTOR >	
* CN281	1-568-942-11	PIN, CONNECTOR 4P	
		< RESISTOR >	
R281	1-249-415-11	CARBON 680 5% 1/4W F	
		< SWITCH >	
S281	1-692-193-11	SWITCH, PUSH (1 KEY) (IN SW)	
S282	1-692-193-11	SWITCH, PUSH (1 KEY) (OUT SW)	
S283	1-692-193-11	SWITCH, PUSH (1 KEY) (LD SW)	

*	1-654-234-11	OPT BOARD	

		< CAPACITOR >	
C701	1-126-059-11	ELECT 10uF 20% 50V	
		< CONNECTOR >	
CN701	1-691-459-11	PIN, CONNECTOR (PC BOARD) 3P	
CN702	1-691-459-21	PIN, CONNECTOR (PC BOARD) 3P	
		< IC >	
IC701	8-749-921-12	IC GP1F32T	

*	A-4673-529-A	POWER BOARD, COMPLETE	

		2-259-121-01 SCREW, TR	
*	4-363-146-00	HEAT SINK, V. OUT	
*	4-941-237-01	HEAT SINK	
		< CAPACITOR >	
C901	1-136-177-00	FILM 1uF 5% 50V	
C902	1-107-611-11	MICA 100PF 5% 500V	
C921	1-110-504-11	ELECT 6800uF 20% 35V	
C922	1-136-165-00	FILM 0.1uF 5% 50V	
C923	1-124-910-11	ELECT 47uF 20% 50V	

Ref.No.	Part No.	Description	Remark	Ref.No.	Part No.	Description	Remark
C924	1-106-343-00	MYLAR	1000PF 5%	200V	D974	8-719-200-02	DIODE 10E2
C925	1-107-611-11	MICA	100PF 5%	500V	D975	8-719-113-38	DIODE RD18ES-T2B1
C926	1-124-922-11	ELECT	1000uF 20%	63V	D976	8-719-111-61	DIODE RD3.9ES-T2B1
C931	1-110-504-11	ELECT	6800uF 20%	35V			
C932	1-136-165-00	FILM	0.1uF 5%	50V			
C933	1-124-910-11	ELECT	47uF 20%	50V			< GROUND PLATE >
C934	1-106-343-00	MYLAR	1000PF 5%	200V	* ET920	4-870-539-00	PLATE, GROUND
C935	1-107-611-11	MICA	100PF 5%	500V			< IC >
C936	1-124-922-11	ELECT	1000uF 20%	63V	IC921	8-759-602-01	IC M5220P
C951	1-126-017-11	ELECT	6800uF 20%	16V	IC951	8-759-604-86	IC M5F7807L
C952	1-126-027-11	ELECT	1000uF 20%	25V	IC952	8-759-231-53	IC TA7805S
C953	1-126-027-11	ELECT	1000uF 20%	25V	IC953	8-759-604-90	IC M5F7907L
C954	1-124-556-11	ELECT	2200uF 20%	16V			< IC LINK >
C955	1-110-335-11	MYLAR	100PF 5%	50V			
C956	1-110-335-11	MYLAR	100PF 5%	50V			
C957	1-110-335-11	MYLAR	100PF 5%	50V	△PS921	1-532-685-00	LINK, IC 0.8A
C961	1-126-015-11	ELECT	3300uF 20%	16V	△PS931	1-532-685-00	LINK, IC 0.8A
C963	1-126-027-11	ELECT	1000uF 20%	25V			< TRANSISTOR >
C970	1-110-335-11	MYLAR	100PF 5%	50V	Q921	8-729-203-05	TRANSISTOR 2SK30A-GR3
C971	1-126-052-11	ELECT	100uF 20%	35V	Q922	8-729-107-53	TRANSISTOR 2SC2275A-P
C972	1-126-059-11	ELECT	10uF 20%	50V	Q931	8-729-203-05	TRANSISTOR 2SK30A-GR3
C973	1-126-023-11	ELECT	100uF 20%	25V	Q932	8-729-141-10	TRANSISTOR 2SA985A-QP
C974	1-126-023-11	ELECT	100uF 20%	25V	Q971	8-729-140-97	TRANSISTOR 2SB734-34
C975	1-110-335-11	MYLAR	100PF 5%	50V			< RESISTOR >
C976	1-110-335-11	MYLAR	100PF 5%	50V	△R901	1-212-976-00	FUSIBLE 56 5% 1/2W
C977	1-110-335-11	MYLAR	100PF 5%	50V	△R902	1-212-994-00	FUSIBLE 330 5% 1/2W
C978	1-162-282-31	CERAMIC	100PF 10%	50V	R921	1-249-520-11	CARBON 47 5% 1/4W
C979	1-164-159-11	CERAMIC	0.1uF 50V		R922	1-247-713-11	CARBON 1K 5% 1/4W F
C980	1-164-159-11	CERAMIC	0.1uF 50V		R923	1-247-713-11	CARBON 1K 5% 1/4W F
		< CONNECTOR >			R924	1-247-717-11	CARBON 2.2K 5% 1/4W F
* CN921	1-564-507-11	PLUG, CONNECTOR 4P			R925	1-247-714-11	CARBON 1.2K 5% 1/4W F
* CN922	1-564-507-11	PLUG, CONNECTOR 4P			R926	1-247-700-11	CARBON 100 5% 1/4W F
* CN923	1-564-508-11	PLUG, CONNECTOR 5P			R931	1-249-520-11	CARBON 47 5% 1/4W
CN951	1-564-511-11	PLUG, CONNECTOR 8P			R932	1-247-713-11	CARBON 1K 5% 1/4W F
CN952	1-564-511-11	PLUG, CONNECTOR 8P			R933	1-247-713-11	CARBON 1K 5% 1/4W F
		< DIODE >			R934	1-247-717-11	CARBON 2.2K 5% 1/4W F
D921	8-719-210-29	DIODE F10P10Q			R935	1-247-714-11	CARBON 1.2K 5% 1/4W F
D922	8-719-210-29	DIODE F10P10Q			R936	1-247-700-11	CARBON 100 5% 1/4W F
D923	8-719-114-49	DIODE RD7.5JS-B2			R971	1-259-444-11	CARBON 4.7K 5% 1/6W
D924	8-719-115-98	DIODE RD10JS-T2B1			R972	1-259-460-11	CARBON 22K 5% 1/6W
D931	8-719-210-29	DIODE F10P10Q			R973	1-259-440-11	CARBON 3.3K 5% 1/6W
D932	8-719-210-29	DIODE F10P10Q					< THERMISTOR >
D933	8-719-114-49	DIODE RD7.5JS-B2			TH903	1-806-882-11	THERMISTOR, POSITIVE
D934	8-719-975-85	DIODE ERB83-004			TH904	1-808-065-11	THERMISTOR, POSITIVE
D951	8-719-047-31	DIODE RBA-402L					*****
D952	8-719-210-21	DIODE 11EQS04					
D971	8-719-200-02	DIODE 10E2					
D972	8-719-200-02	DIODE 10E2					
D973	8-719-200-02	DIODE 10E2					

The components identified by mark △ or dotted line with mark △ are critical for safety. Replace only with part number specified.

SERVO

Ref. No.	Part No.	Description	Remark	Ref. No.	Part No.	Description	Remark
*	A-4673-224-A	SERVO BOARD, COMPLETE *****		C201	1-125-622-11	CAP, DOUBLE LAYERS	0.10F
		< CAPACITOR >		C202	1-163-038-91	CERAMIC CHIP 0.1uF	25V
C93	1-124-995-11	ELECT 220uF 20%	10V	C203	1-163-038-91	CERAMIC CHIP 0.1uF	25V
C94	1-124-995-11	ELECT 220uF 20%	10V	C204	1-163-038-91	CERAMIC CHIP 0.1uF	25V
C95	1-124-995-11	ELECT 220uF 20%	10V	C251	1-164-232-11	CERAMIC CHIP 0.01uF	50V
C96	1-163-141-00	CERAMIC CHIP 0.001uF 5%	50V	C252	1-163-038-91	CERAMIC CHIP 0.1uF	25V
C97	1-126-162-11	ELECT 3.3uF 20%	50V	C261	1-126-177-11	ELECT 100uF 20%	10V
						< CONNECTOR >	
C101	1-126-177-11	ELECT 100uF 20%	10V	* CN91	1-573-278-11	PIN, CONNECTOR 8P	
C102	1-126-177-11	ELECT 100uF 20%	10V	CN101	1-568-795-11	SOCKET, CONNECTOR 12P	
C103	1-163-017-00	CERAMIC CHIP 0.0047uF 5%	50V	CN102	1-580-473-11	SOCKET, CONNECTOR 26P	
C104	1-163-133-00	CERAMIC CHIP 470PF 5%	50V	CN103	1-580-781-11	PIN, CONNECTOR (PC BOARD) 7P	
C105	1-164-004-11	CERAMIC CHIP 0.1uF 10%	25V	CN104	1-580-774-11	PIN, CONNECTOR (PC BOARD) 6P	
C106	1-163-133-00	CERAMIC CHIP 470PF 5%	50V	CN105	1-580-771-11	PIN, CONNECTOR (PC BOARD) 3P	
C107	1-163-809-11	CERAMIC CHIP 0.047uF 10%	25V	CN201	1-580-774-11	PIN, CONNECTOR (PC BOARD) 6P	
C108	1-163-145-00	CERAMIC CHIP 0.0015uF 5%	50V	CN202	1-580-775-11	PIN, CONNECTOR (PC BOARD) 8P	
C109	1-163-117-00	CERAMIC CHIP 100PF 5%	50V	CN203	1-580-770-11	PIN, CONNECTOR (PC BOARD) 2P	
C110	1-164-489-11	CERAMIC CHIP 0.22uF 10%	16V	CN204	1-580-770-11	PIN, CONNECTOR (PC BOARD) 2P	
C111	1-164-232-11	CERAMIC CHIP 0.01uF	50V	CN251	1-580-774-11	PIN, CONNECTOR (PC BOARD) 6P	
C112	1-163-038-91	CERAMIC CHIP 0.1uF	25V			< DIODE >	
C113	1-163-038-91	CERAMIC CHIP 0.1uF	25V	D201	8-719-914-44	DIODE DAP202K	
C114	1-163-038-91	CERAMIC CHIP 0.1uF	25V	D202	8-719-976-96	DIODE DTZ4.7C	
C115	1-164-346-11	CERAMIC CHIP 1uF	16V	D261	8-719-938-07	LED GL480	
C131	1-163-109-00	CERAMIC CHIP 47PF 5%	50V			< IC >	
C132	1-163-017-00	CERAMIC CHIP 0.0047uF 5%	50V	IC91	8-759-636-16	IC M51957AL	
C133	1-163-017-00	CERAMIC CHIP 0.0047uF 5%	50V	IC101	8-752-361-94	IC CXD2515Q	
C134	1-163-109-00	CERAMIC CHIP 47PF 5%	50V	IC102	8-759-071-79	IC BA6297AFP	
C135	1-163-121-00	CERAMIC CHIP 150PF 5%	50V	IC103	8-759-100-96	IC uPC4558G2	
C136	1-163-121-00	CERAMIC CHIP 150PF 5%	50V	IC104	8-759-071-79	IC BA6297AFP	
C137	1-163-121-00	CERAMIC CHIP 150PF 5%	50V	IC105	8-759-071-79	IC BA6297AFP	
C138	1-163-121-00	CERAMIC CHIP 150PF 5%	50V	IC201	8-752-864-35	IC CXP84124-025Q	
C139	1-163-038-91	CERAMIC CHIP 0.1uF	25V	IC202	8-759-289-95	IC LH5160TG	
C140	1-164-336-11	CERAMIC CHIP 0.33uF	25V	IC203	8-759-822-09	IC LB1641	
C141	1-163-141-00	CERAMIC CHIP 0.001uF 5%	50V	IC261	8-749-010-61	IC IS471F	
C142	1-163-127-00	CERAMIC CHIP 270PF 5%	50V			< TRANSISTOR >	
C143	1-163-038-91	CERAMIC CHIP 0.1uF	25V	Q101	8-729-901-06	TRANSISTOR DTA144EK	
C144	1-163-038-91	CERAMIC CHIP 0.1uF	25V	Q102	8-729-901-01	TRANSISTOR DTC144EK	
C145	1-163-038-91	CERAMIC CHIP 0.1uF	25V	Q103	8-729-901-06	TRANSISTOR DTA144EK	
C161	1-163-145-00	CERAMIC CHIP 0.0015uF 5%	50V	Q104	8-729-901-01	TRANSISTOR DTC144EK	
C162	1-164-489-11	CERAMIC CHIP 0.22uF 10%	16V	Q201	8-729-901-04	TRANSISTOR DTA114EK	
C163	1-164-492-11	CERAMIC CHIP 0.15uF 10%	16V	Q202	8-729-900-53	TRANSISTOR DTC114EK	
C171	1-163-038-91	CERAMIC CHIP 0.1uF	25V			< RESISTOR >	
C172	1-163-038-91	CERAMIC CHIP 0.1uF	25V	R91	1-216-689-11	METAL CHIP 39K 0.5% 1/10W	
C173	1-163-038-91	CERAMIC CHIP 0.1uF	25V	R92	1-216-077-00	METAL CHIP 15K 5% 1/10W	
C174	1-164-336-11	CERAMIC CHIP 0.33uF	25V	R93	1-216-061-00	METAL CHIP 3.3K 5% 1/10W	
C175	1-163-038-91	CERAMIC CHIP 0.1uF	25V				
C176	1-163-038-91	CERAMIC CHIP 0.1uF	25V				
C177	1-164-336-11	CERAMIC CHIP 0.33uF	25V				
C178	1-163-038-91	CERAMIC CHIP 0.1uF	25V				

Ref. No.	Part No.	Description	Remark	Ref. No.	Part No.	Description	Remark
R101	1-216-077-00	METAL CHIP	15K 5% 1/10W	R167	1-216-065-00	METAL CHIP	4.7K 5% 1/10W
R102	1-216-097-00	METAL CHIP	100K 5% 1/10W	R168	1-216-097-00	METAL CHIP	100K 5% 1/10W
R103	1-216-077-00	METAL CHIP	15K 5% 1/10W	R171	1-216-001-00	METAL CHIP	10 5% 1/10W
R104	1-216-025-91	METAL GLAZE	100 5% 1/10W	R172	1-216-105-91	METAL GLAZE	220K 5% 1/10W
R105	1-216-061-00	METAL CHIP	3.3K 5% 1/10W	R173	1-216-057-00	METAL CHIP	2.2K 5% 1/10W
R106	1-216-061-00	METAL CHIP	3.3K 5% 1/10W	R174	1-216-057-00	METAL CHIP	2.2K 5% 1/10W
R107	1-216-073-00	METAL CHIP	10K 5% 1/10W	R175	1-216-105-91	METAL GLAZE	220K 5% 1/10W
R108	1-216-121-00	METAL CHIP	1M 5% 1/10W	R176	1-216-308-00	METAL CHIP	4.7 5% 1/10W
R109	1-216-105-91	METAL GLAZE	220K 5% 1/10W	R179	1-216-001-00	METAL CHIP	10 5% 1/10W
R110	1-216-073-00	METAL CHIP	10K 5% 1/10W	R180	1-216-105-91	METAL GLAZE	220K 5% 1/10W
R111	1-216-041-00	METAL CHIP	470 5% 1/10W	R181	1-216-057-00	METAL CHIP	2.2K 5% 1/10W
R112	1-216-041-00	METAL CHIP	470 5% 1/10W	R182	1-216-057-00	METAL CHIP	2.2K 5% 1/10W
R113	1-216-041-00	METAL CHIP	470 5% 1/10W	R183	1-216-105-91	METAL GLAZE	220K 5% 1/10W
R114	1-216-037-00	METAL CHIP	330 5% 1/10W	R184	1-216-308-00	METAL CHIP	4.7 5% 1/10W
R115	1-216-073-00	METAL CHIP	10K 5% 1/10W	R201	1-216-013-00	METAL CHIP	33 5% 1/10W
R116	1-216-049-91	METAL GLAZE	1K 5% 1/10W	R202	1-216-069-00	METAL CHIP	6.8K 5% 1/10W
R117	1-216-073-00	METAL CHIP	10K 5% 1/10W	R203	1-216-069-00	METAL CHIP	6.8K 5% 1/10W
R118	1-216-097-00	METAL CHIP	100K 5% 1/10W	R204	1-216-069-00	METAL CHIP	6.8K 5% 1/10W
R119	1-216-085-00	METAL CHIP	33K 5% 1/10W	R205	1-216-069-00	METAL CHIP	6.8K 5% 1/10W
R131	1-216-689-11	METAL CHIP	39K 0.5% 1/10W	R206	1-216-069-00	METAL CHIP	6.8K 5% 1/10W
R132	1-216-689-11	METAL CHIP	39K 0.5% 1/10W	R207	1-216-069-00	METAL CHIP	6.8K 5% 1/10W
R133	1-216-083-00	METAL CHIP	27K 5% 1/10W	R208	1-216-069-00	METAL CHIP	6.8K 5% 1/10W
R134	1-216-083-00	METAL CHIP	27K 5% 1/10W	R209	1-216-069-00	METAL CHIP	6.8K 5% 1/10W
R135	1-216-085-00	METAL CHIP	33K 5% 1/10W	R210	1-216-073-00	METAL CHIP	10K 5% 1/10W
R136	1-216-085-00	METAL CHIP	33K 5% 1/10W	R212	1-216-073-00	METAL CHIP	10K 5% 1/10W
R137	1-216-689-11	METAL CHIP	39K 0.5% 1/10W	R213	1-216-073-00	METAL CHIP	10K 5% 1/10W
R138	1-216-689-11	METAL CHIP	39K 0.5% 1/10W	R214	1-216-097-00	METAL CHIP	100K 5% 1/10W
R139	1-216-083-00	METAL CHIP	27K 5% 1/10W	R215	1-216-073-00	METAL CHIP	10K 5% 1/10W
R140	1-216-083-00	METAL CHIP	27K 5% 1/10W	R261	1-216-021-00	METAL CHIP	68 5% 1/10W
R141	1-216-085-00	METAL CHIP	33K 5% 1/10W				
R142	1-216-085-00	METAL CHIP	33K 5% 1/10W			< VIBRATOR >	
R143	1-216-093-00	METAL CHIP	68K 5% 1/10W	X201	1-577-377-11	VIBRATOR, CERAMIC (10MHz)	
R144	1-216-093-00	METAL CHIP	68K 5% 1/10W				
R145	1-216-085-00	METAL CHIP	33K 5% 1/10W				
R146	1-216-085-00	METAL CHIP	33K 5% 1/10W				
R147	1-216-308-00	METAL CHIP	4.7 5% 1/10W				
R148	1-216-073-00	METAL CHIP	10K 5% 1/10W	*	1-654-238-11	SW BOARD	

R149	1-216-073-00	METAL CHIP	10K 5% 1/10W				< CONNECTOR >
R150	1-216-073-00	METAL CHIP	10K 5% 1/10W				
R151	1-216-097-00	METAL CHIP	100K 5% 1/10W	* CN995	1-696-874-21	LEAD (WITH CONNECTOR)	
R152	1-216-001-00	METAL CHIP	10 5% 1/10W				< SWITCH >
R153	1-216-001-00	METAL CHIP	10 5% 1/10W				
R154	1-216-073-00	METAL CHIP	10K 5% 1/10W	△S991	1-572-267-51	SWITCH, PUSH (AC POWER) (1 KEY) (POWER)	
R155	1-216-097-00	METAL CHIP	100K 5% 1/10W				
R161	1-216-075-00	METAL CHIP	12K 5% 1/10W				
R162	1-216-091-00	METAL CHIP	56K 5% 1/10W				
R163	1-216-093-00	METAL CHIP	68K 5% 1/10W				
R164	1-216-093-00	METAL CHIP	68K 5% 1/10W				
R165	1-216-093-00	METAL CHIP	68K 5% 1/10W				
R166	1-216-097-00	METAL CHIP	100K 5% 1/10W				

The components identified by mark △ or dotted line with mark △ are critical for safety. Replace only with part number specified.

VOLUME

Ref. No.	Part No.	Description	Remark	Ref. No.	Part No.	Description	Remark
*	1-654-237-11	VOLUME BOARD *****				ACCESSORIES & PACKING MATERIALS *****	
*	4-962-201-01	PLATE (HP), GROUND < CAPACITOR >				1-467-889-11 REMOTE COMMANDER (RM-D921) 1-590-925-31 CORD, CONNECTION (AUDIO 100cm) 3-707-584-21 COVER, BATTERY (for RM-D921) 3-759-341-11 MANUAL, INSTRUCTION (ENGLISH, FRENCH, SPANISH, SWEDISH) (AEP)	
C350	1-164-159-11	CERAMIC 0.1uF	50V			3-759-341-41 MANUAL, INSTRUCTION (GERMAN, DUTCH, ITALIAN, PORTUGUESE)	
C351	1-164-159-11	CERAMIC 0.1uF	50V				
C461	1-162-290-31	CERAMIC 470PF	10% 50V				
C475	1-164-159-11	CERAMIC 0.1uF	50V				
C561	1-162-290-31	CERAMIC 470PF	10% 50V				
		< CONNECTOR >		*	4-971-334-01	CUSHION	
CN351	1-564-523-11	PLUG, CONNECTOR 8P		*	4-972-153-01	INDIVIDUAL CARTON	
* CN352	1-580-772-11	PIN, CONNECTOR (PC BOARD) 4P			A-4660-688-A	STABILIZER ASSY	
* CN461	1-573-262-11	PIN, CONNECTOR 3P		*****			
		< IC >				***** HARDWARE LIST *****	
IC350	8-759-962-08	IC BA6208		#1	7-685-246-14	SCREW +KTP 3X8 TYPE2 NON-SLIT (SILVER).. (GOLD)	
		< JACK >		#1	7-685-246-19	SCREW +KTP 3X8 TYPE2 NON-SLIT (BLACK).. (BLACK)	
J461	1-750-162-61	JACK (LARGE TYPE) (PHONES) (BLACK)		#2	7-685-871-01	SCREW +BVTT 3X6 (S)	
J461	1-766-850-11	JACK (LARGE TYPE) (PHONES) (GOLD)		#3	7-682-560-04	SCREW +BVTT 4X6 (S)	
		< COIL >		#4	7-682-549-09	SCREW +BVTT 3X10 (S)	
L461	1-412-473-21	INDUCTOR 0uH		#5	7-682-564-09	SCREW +B 4X14	
L561	1-412-473-21	INDUCTOR 0uH		#6	7-682-548-09	SCREW +BVTT 3X8 (S)	
		< VARIABLE RESISTOR >		#7	7-685-134-19	SCREW +PTPW 2.6X8 (TYPE2)	
RV350	1-223-747-11	RES, VAR, CARBON 10K/10K (LINE OUT, PHONE LEVEL)		#8	7-621-772-30	SCREW +B 2X6	
		*****		#9	7-682-903-01	SCREW +PWH 3X5	
		MISCELLANEOUS *****		#10	7-682-902-11	SCREW +PWH 2.6X5	
△109	1-558-568-21	CORD, POWER		#11	7-621-775-50	SCREW +B 2.6X10	
119	1-533-233-11	HOLDER, FUSE		#12	7-628-253-00	SCREW +PS 2X4	
705	1-769-110-11	WIRE (FLAT TYPE) (26 CORE)		#13	7-685-246-14	SCREW +KTP 3X8 TYPE2 NON-SLIT	
709	1-769-109-11	WIRE (FLAT TYPE) (12 CORE)		#14	7-685-534-19	SCREW +BTP 2.6X8 TYPE2 N-S	
△805	8-848-368-11	OPTICAL PICK-UP BLOCK KSS-273A/J-N		#15	7-685-646-79	SCREW, TAPPING	
△F991	1-532-279-00	FUSE, TIME-LAG (0.5A 250V)		#16	7-682-548-04	SCREW +BVTT 3X8 (S)	
△F992	1-532-279-00	FUSE, TIME-LAG (0.5A 250V)		#17	7-627-852-07	SCREW, PRECISION +P 1.7X2.5	
M21	X-4945-920-1	MOTOR ASSY (SLED)		#19	7-685-645-79	SCREW +BVTP 3X6 TYPE2 N-S	
M271	X-4945-565-1	MOTOR ASSY (LOADING)		#20	7-685-647-79	SCREW +P 3X10 TYPE2 NON-SLIT	
△T901	1-427-816-11	TRANSFORMER, POWER		#21	7-627-852-58	SCREW, PRECISION +P 1.7X5 TYPE3	
△T902	1-427-817-11	TRANSFORMER, POWER					

The components identified by mark △ or dotted line with mark △ are critical for safety. Replace only with part number specified.

CDP-XA5ES





SONY SERVICE MANUAL

AEP Model

CORRECTION-1

Correct your service manual as shown below.

 : indicates corrected portion.

Page	INCORRECT			CORRECT	
	Ref.No.	Part No.	Description	Part No.	Description
40	* 701	A-4673-224-A	SERVO BOARD, COMPLETE	* A-4673-678-A 	SERVO BOARD, COMPLETE
50	*	A-4673-224-A	SERVO BOARD, COMPLETE	* A-4673-678-A 	SERVO BOARD, COMPLETE
	CN203	1-580-770-11	PIN, CONNECTOR (PC BOARD) 2P	deleted 	
	CN204	1-580-770-11	PIN, CONNECTOR (PC BOARD) 2P	deleted 	

(ECN-CD500577)