

CDP-XE200/XE300

SERVICE MANUAL

Canadian Model
AEP Model
UK Model
Australian Model
CDP-XE200/XE300
E Model
Chinese Model
CDP-XE200



Photo: CDP-XE300

Model Name Using Similar Mechanism	CDP-XE500
CD Mechanism Type	CDM14-5BD20
Base Unit Name	BU-5BD20

SPECIFICATIONS

Compact disc player

Laser	Semiconductor laser ($\lambda = 780 \text{ nm}$) Emission duration: continuous
Laser output	Max 44.6 μW * * This output is the value measured at a distance of 200 mm from the objective lens surface on the Optical Pick-up block with 7 mm aperture.
Frequency response	2 Hz to 20 kHz $\pm 0.5 \text{ dB}$
Signal-to-noise ratio	More than 100 dB
Dynamic range	More than 98 dB
Harmonic distortion	Less than 0.0045%
Channel separation	More than 95 dB

Outputs

	Jack type	Maximum output level	Load impedance
LINE OUT	Phono jacks	2 V (at 50 kilohms)	Over 10 kilohms

General

Power requirements

Where purchased	Power requirements
Europe	220 V - 230 V AC, 50/60 Hz
Canadian	120 V AC, 60 Hz
Australian	240 V AC, 50 Hz
Other countries	110 V - 120 V or 220 V - 240 V AC, adjustable, 50/60 Hz

Power consumption	10 W
Dimensions (approx.) (w/h/d)	430 \times 95 \times 295 mm (17 \times 3 3/4 \times 11 5/8 in.) incl. projecting parts
Mass (approx.)	2.9 kg (6 lbs 7 oz)

Supplied accessories

Audio cord (2 phono plugs - 2 phono plugs) (1)
Remote commander (remote) RM-D420 (CDP-XE300) (1)
Sony SUM-3 (NS) batteries (CDP-XE300) (2)

Design and specifications are subject to change without notice.



COMPACT DISC PLAYER
SONY[®]

The laser component in this product is capable of emitting radiation exceeding the limit for Class 1.

The following caution label is located inside of the unit.

CAUTION	; INVISIBLE LASER RADIATION WHEN OPEN. AVOID EXPOSURE TO BEAM.
ADVARSEL	; USYNLIG LASERSTRÅLING VED ÅBNING NÅR SIKKERHEDSÅFBRYDEDE ER UDE AF FUNKTION. UNDGÅ UDSÆTTELSE FOR STRÅLING.
VARO!	; AVATTAESSA JA SUOJALUKITUS OHTETTAESSA DLET ALTIINA LASERSÄTELYLLE.
WARNING	; LASERSTRÅLING NÅR DENNA DEL ÅR OPPNÅD OCH SPÄRREN ÅR URÖPPNAD.
ADVARSEL	; USYNLIG LASERSTRÅLING NÅR DEKSEL ÅPNES UNNGÅ EKSPONERING FOR STRÅLEN.



This appliance is classified as a CLASS 1 LASER product. The CLASS 1 LASER PRODUCT MARKING is located on the rear exterior.

CAUTION

Use of controls or adjustments or performance of procedures other than those specified herein may result in hazardous radiation exposure.

Notes on Chip Component Replacement

- Never reuse a disconnected chip component.
- Notice that the minus side of a tantalum capacitor may be damaged by heat.

MODEL IDENTIFICATION

– Back Panel –

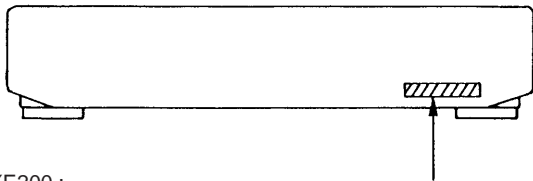

- CDP-XE200 :
- Canadian Model : 4-978-388-4□
 - Australian Model : 4-978-388-5□
 - E Model : 4-978-388-9□
 - Chinese Model : 4-979-971-0□
 - UK Model : 4-979-971-1□
 - AEP, German, East European Model : 4-979-971-2□
- CDP-XE300 :
- AEP, German, East European Model : 4-978-388-2□
 - UK Model : 4-978-388-3□
 - Australian Model : 4-978-388-6□
 - Canadian Model : 4-978-388-8□

SAFETY CHECK-OUT

After correcting the original service problem, perform the following safety check before releasing the set to the customer: Check the antenna terminals, metal trim, “metallized” knobs, screws, and all other exposed metal parts for AC leakage. Check leakage as described below.

LEAKAGE TEST

The AC leakage from any exposed metal part to earth ground and from all exposed metal parts to any exposed metal part having a return to chassis, must not exceed 0.5 mA (500 microamperes). Leakage current can be measured by any one of three methods.

1. A commercial leakage tester, such as the Simpson 229 or RCA WT-540A. Follow the manufacturers’ instructions to use these instruments.
2. A battery-operated AC milliammeter. The Data Precision 245 digital multimeter is suitable for this job.
3. Measuring the voltage drop across a resistor by means of a VOM or battery-operated AC voltmeter. The “limit” indication is 0.75 V, so analog meters must have an accurate low-voltage scale. The Simpson 250 and Sanwa SH-63Trd are examples of a passive VOM that is suitable. Nearly all battery operated digital multimeters that have a 2V AC range are suitable. (See Fig. A)

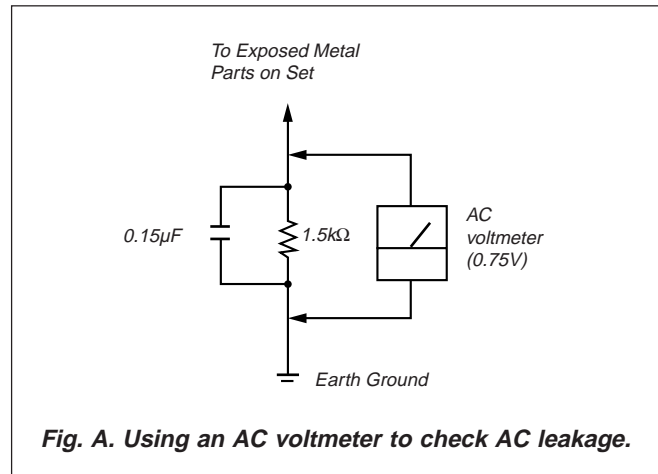

Fig. A. Using an AC voltmeter to check AC leakage.

NOTES ON HANDLING THE OPTICAL PICK-UP BLOCK OR BASE UNIT

The laser diode in the optical pick-up block may suffer electrostatic breakdown because of the potential difference generated by the charged electrostatic load, etc. on clothing and the human body. During repair, pay attention to electrostatic breakdown and also use the procedure in the printed matter which is included in the repair parts.
The flexible board is easily damaged and should be handled with care.

NOTES ON LASER DIODE EMISSION CHECK

The laser beam on this model is concentrated so as to be focused on the disc reflective surface by the objective lens in the optical pick-up block. Therefore, when checking the laser diode emission, observe from more than 30 cm away from the objective lens.

LASER DIODE AND FOCUS SEARCH OPERATION CHECK

1. Make POWER switch on with no disc inserted and disc table closed.
2. Confirm that the following operation is performed while observing the objective lens.

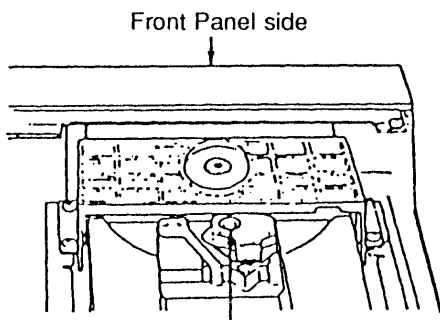

- ① Confirm that laser beam is spread.
- ② Up and down motion of the objective lens. (3 times)

TABLE OF CONTENTS

1. GENERAL
 Identifying the Parts 4
 Playing a CD 5

2. DISASSEMBLY
 2-1. Front Panel 6
 2-2. Base Unit Block 6

3. ELECTRICAL BLOCK CHECKING 7

4. DIAGRAMS
 4-1. IC Pin Functions 9
 4-2. Printed Wiring Board – BD Section – 13
 4-3. Schematic Diagram – BD Section – 15
 4-4. Printed Wiring Boards – Main Section – 17
 4-5. Schematic Diagram – Main Section – 19

5. EXPLODED VIEWS
 5-1. Case Section 26
 5-2. Back Panel Section 27
 5-3. CD Mechanism Section 28
 5-4. Base Unit Section 29

6. ELECTRICAL PARTS LIST 30

SAFETY-RELATED COMPONENT WARNING!!

COMPONENTS IDENTIFIED BY MARK \triangle OR DOTTED LINE WITH MARK \triangle ON THE SCHEMATIC DIAGRAMS AND IN THE PARTS LIST ARE CRITICAL TO SAFE OPERATION. REPLACE THESE COMPONENTS WITH SONY PARTS WHOSE PART NUMBERS APPEAR AS SHOWN IN THIS MANUAL OR IN SUPPLEMENTS PUBLISHED BY SONY.

ATTENTION AU COMPOSANT AYANT RAPPORT À LA SÉCURITÉ!!

LES COMPOSANTS IDENTIFIÉS PAR UNE MARQUE \triangle SUR LES DIAGRAMMES SCHÉMATIQUES ET LA LISTE DES PIÈCES SONT CRITIQUES POUR LA SÉCURITÉ DE FONCTIONNEMENT. NE REMPLACER CES COMPOSANTS QUE PAR DES PIÈCES SONY DONT LES NUMÉROS SONT DONNÉS DANS CE MANUEL OU DANS LES SUPPLÉMENTS PUBLIÉS PAR SONY.

SECTION 1 GENERAL

Front Panel/Remote Commander

- 1 POWER switch
- 2 Disc tray
- 3 OPEN/CLOSE button
- 4 (manual search) button
- 5 CHECK (program check) button
- 6 CLEAR (program clear) button
- 7 ENTER button
- 8 AMS (AMS*) control
- 9 (Stop) button
- 10 (Pause) button
- 11 (Play) button
- 12 Display
- 13 TIME button
- 14 REPEAT button
- 15 PLAY MODE button
- 16 Play Mode buttons
- CONTINUE button
- SHUFFLE button
- PROGRAM button
- 17 Numeric buttons
- 18 >10 (over 10) button
- 19 TIME button
- 20 (AMS*) button
- 21 FADER button

*AMS is the abbreviation of Automatic Music Sensor.

IDENTIFYING THE PARTS

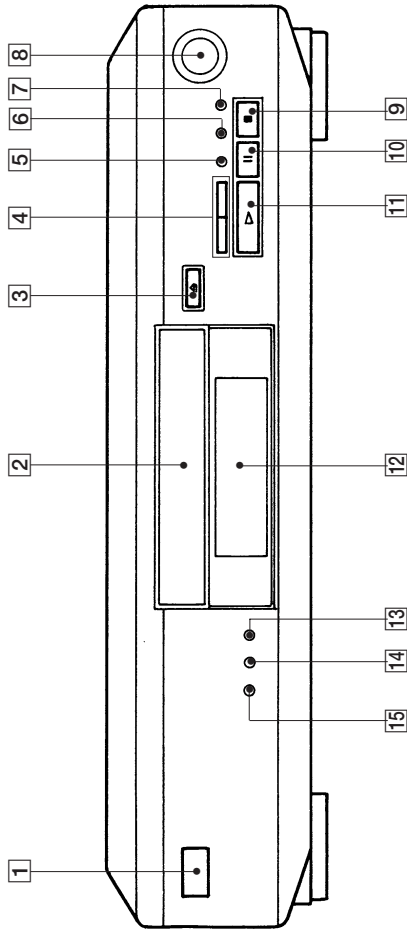

RM-D420 (CDP-XE300 only)

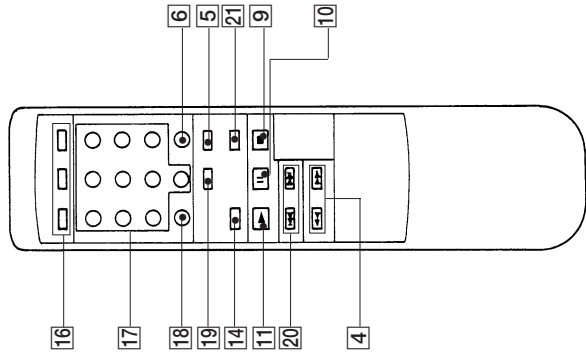



Using the Display

You can check information about the disc using the display.

- CDP-XE500

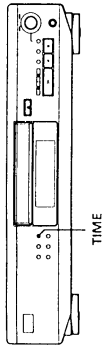

- CDP-XE300 and CDP-XE200

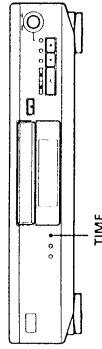

Display information while playing a disc

While playing a disc, the display shows the current track number, playing time and the music calendar.

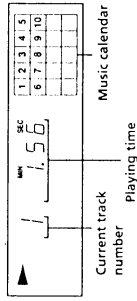

The track numbers in the music calendar disappear after they are played.

Checking the remaining time

Each time you press TIME while playing a disc, the display changes as shown in the chart below.

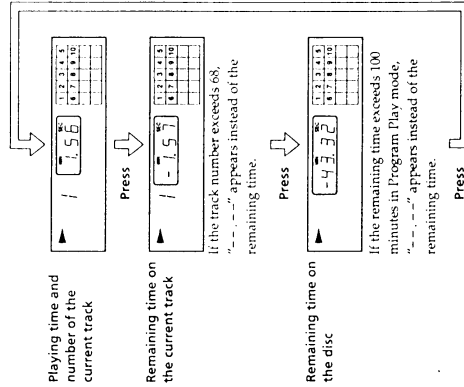

Checking the total number and playing time of the tracks

Press TIME before you start playing. The display shows the total number of tracks, total playing time and music calendar.

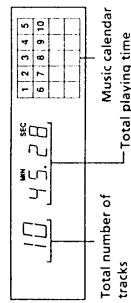

While in Shuffle Play mode ("SHUFFLE" appears in the display; see page 9), a one-second access time blank is added between each track. This increase is automatically added to the total playing time in the display.

The information also appears when you press OPEN/CLOSE to close the disc tray.

SECTION 2 DISASSEMBLY

Note : Follow the disassembly procedure in the numerical order given.

2-1. FRONT PANEL

- When removing the front panel assembly on electric power failure, first open the loading block by turning cam with a screwdriver as shown in the figure, next pull out the loading block with hand, and remove the loading panel as shown in the figure, then remove the front panel assembly.

- 3 Remove loading panel in the arrow direction

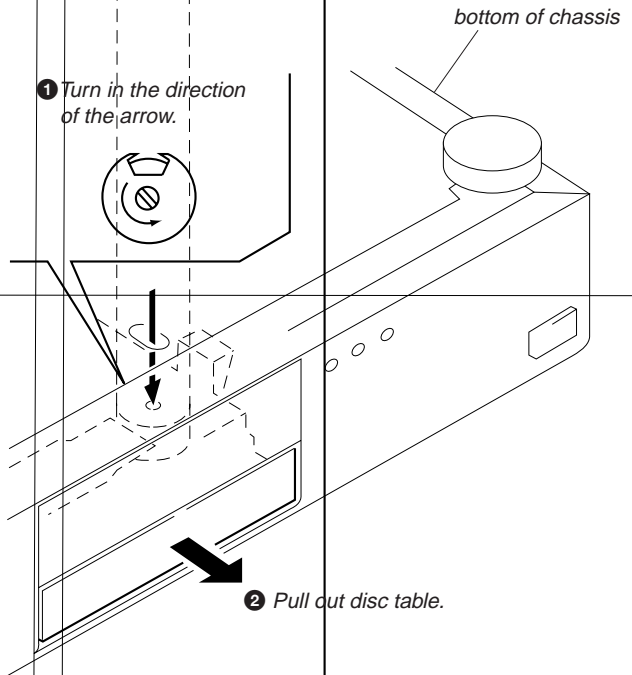

2-2. BASE UNIT BLOCK

- 1 Turn the cam to direction of arrow (Counter clockwise) by minus screw driver.
- 2 Take off the disc table.
- 3 Remove the yoke bracket.
- 4 Remove the MD (BU-5BD20) to the direction of arrow.

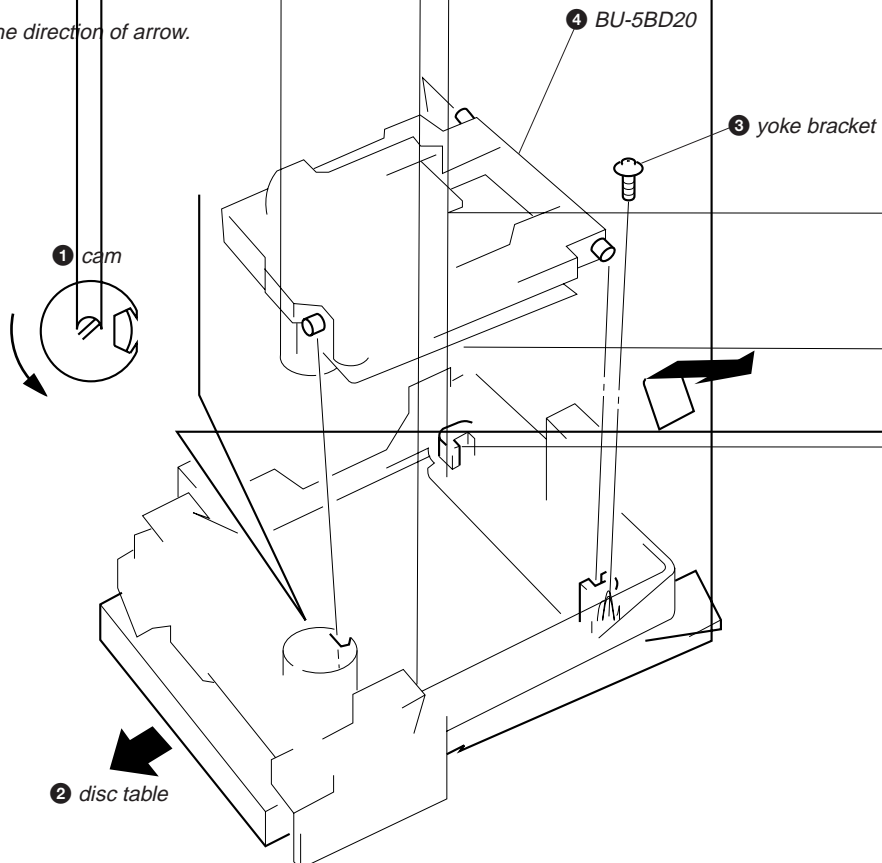

SECTION 3 ELECTRICAL BLOCK CHECKING

Note :

1. CD Block is basically designed to operate without adjustment. Therefore, check each item in order given.
2. Use YEDS-18 disc (3-702-101-01) unless otherwise indicated.
3. Use an oscilloscope with more than 10MΩ impedance.
4. Clean the objective lens using an applicator with neutral detergent when the signal level is low than specified value with the following checks.

S Curve Check

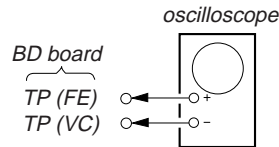

Procedure :

1. Connect oscilloscope to test point TP (FE) on BD board.
2. Connect between test point TP (FEI) and TP (VC) by lead wire.
3. Turn Power switch on.
4. Put disc (YEDS-18) in and turn Power switch on again and actuate the focus search. (Actuate the focus search when disc table is moving in and out.)
5. Check if the oscilloscope waveform (S-curve) is symmetrical between A and B. And confirm peak to peak level within 3 ± 1 Vp-p.

S-curve waveform

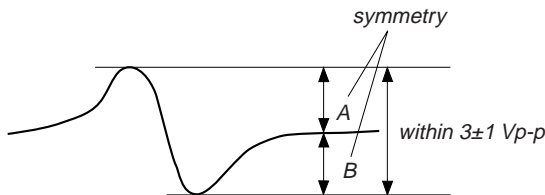

6. After check, remove the lead wire connected in step 2.

Note :

- Try to measure several times to make sure than the ratio of A : B or B : A is more than 10 : 7.
- Set sweep time as long as possible and set the brightness to obtain best waveform.

RF Level Check

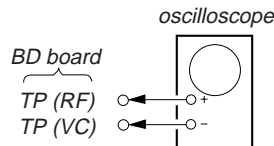

Procedure :

1. Connect oscilloscope to test point TP (RF) on BD board.
2. Turn Power switch on.

3. Put disc (YEDS-18) in and playback.
4. Confirm that oscilloscope waveform is clear and check if RF signal level is correct or not.

Note :

A clear RF signal waveform means that the shape “◇” can be clearly distinguished at the center of the waveform.

RF signal waveform

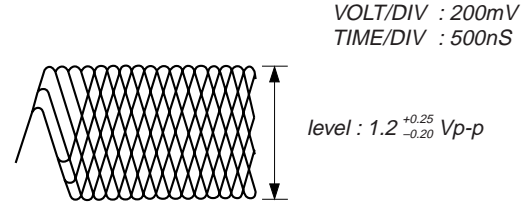

E-F Balance (1 Track Jump) Check

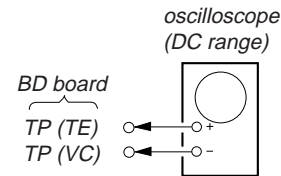

Procedure :

1. Connect oscilloscope to test point TP (TE) on BD board .
 2. Turn Power switch on.
 3. Put disc (YEDS-18) in to play the number five track.
 4. Press the “|| (pause)” button. (Becomes the 1 track jump mode.)
 5. Check the level B of the oscilloscope’s waveform and the A (DC voltage) of the following :
- $A/B \times 100 = \text{less than } \pm 20\%$.

1 track jump waveform

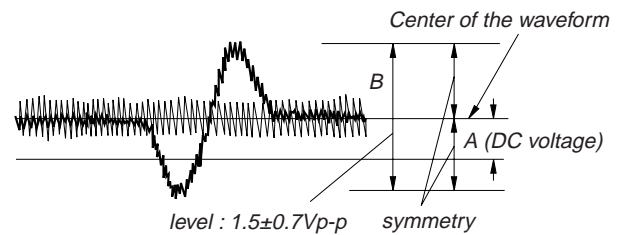

RF PLL Free-run Frequency Check

Procedure :

1. Connect frequency counter to test point (PLCK) with lead wire.

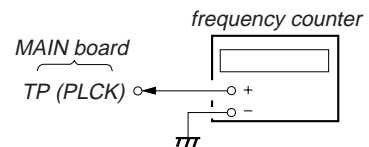

2. Turn Power switch on.
3. Confirm that reading on frequency counter is 4.3218MHz.

Adjustment Location : BD board

-BD board (conductor side) -

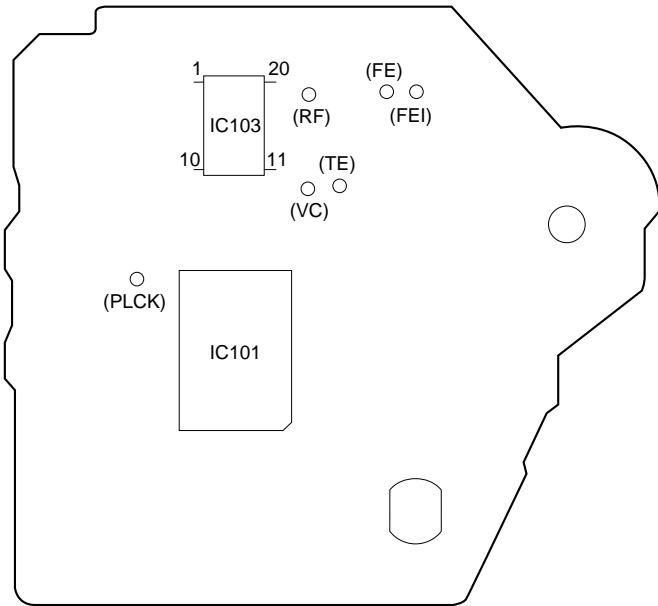

SECTION 4 DIAGRAMS

4-1. IC PIN FUNCTIONS

• IC101 CXD2545Q (DIGITAL SERVO & DIGITAL SIGNAL PROCESSOR)

Pin No.	Pin Name	I/O	Function
1	SRON	O	Sled drive output (Not used.)
2	SRDR	O	Sled drive output
3	SFON	O	Sled drive output (Not used.)
4	TFDR	O	Tracking drive output
5	TRON	O	Tracking drive output (Not used.)
6	TRDR	O	Tracking drive output
7	TFON	O	Tracking drive output (Not used.)
8	FFDR	O	Focus drive output
9	FRON	O	Focus drive output (Not used.)
10	FRDR	O	Focus drive output
11	FFON	O	Focus drive output (Not used.)
12	VCOO	O	VCO output for analog EFM PLL. (Not used.)
13	VCOI	I	VCO input for analog EFM PLL. (Ground)
14	TEST	I	TEST pin connected normally to Ground.
15	DVSS	—	Digital Ground
16	TES2	I	TEST pin connected normally to Ground.
17	TES3	I	TEST pin connected normally to Ground.
18	PDO	O	Charge-pump output for analog EFM PLL. (Not used.)
19	VPCO	O	Charge-pump output for variable pitch PLL. (Not used.)
20	VCKI	I	Clock input from variable pitch external VCO. (Ground)
21	AVD2	—	Analog power supply
22	IGEN	I	Power supply pin for operational amplifiers.
23	AVS2	—	Analog Ground
24	ADIO	I	(Not used.)
25	RFC	O	(Not used.)
26	RFDC	I	RF signal input
27	TE	I	Tracking error signal input
28	SE	I	Sled error signal input
29	FE	I	Focus error signal input
30	VC	I	Center voltage input pin
31	FILO	O	Filter output for master PLL.
32	FILI	I	Filter input for master PLL.
33	PCO	O	Charge-pump output for master PLL.
34	CLTV	I	Control voltage input for master VCO.
35	AVS1	—	Analog Ground
36	RFAC	I	EFM signal input
37	BIAS	I	Asymmetry circuit constant current input
38	ASYI	I	Asymmetry compare voltage input
39	ASYO	O	EFM full swing output
40	AVD1	—	Analog power supply
41	DVDD	—	Digital power supply
42	ASYE	I	Asymmetry circuit ON/OFF
43	PSSL	I	Audio data output mode selection input. (Ground)
44	WDCK	O	48-bit slot D/A interface. Word clock
45	LRCK	O	48-bit slot D/A interface. LR clock
46	DATA	O	DA 16 output when PSSL=1. 48-bit slot serial data when PSSL=0.
47	BCLK	O	DA 15 output when PSSL=1. 48-bit slot data when PSSL=0.

Pin No.	Pin Name	I/O	Function
48	64DATA	O	DA 14 output when PSSL=1. 64-bit slot data when PSSL=0. (Not used.)
49	64BCLK	O	DA 13 output when PSSL=1. 64-bit slot data when PSSL=0. (Not used.)
50	64LRCK	O	DA 12 output when PSSL=1. 64-bit slot data when PSSL=0. (Not used.)
51	GTOP	O	DA 11 output when PSSL=1. GTOP output when PSSL=0. (Not used.)
52	XUGF	O	DA 10 output when PSSL=1. XUGF output when PSSL=0. (Not used.)
53	XPLCK	O	DA 09 output when PSSL=1. XPLCK output when PSSL=0.
54	GFS	O	DA 08 output when PSSL=1. GFS output when PSSL=0.
55	PFCK	O	DA 07 output when PSSL=1. RFCK output when PSSL=0.
56	C2PO	O	DA 06 output when PSSL=1. C2PO output when PSSL=0. (Not used.)
57	XRAOF	O	DA 05 output when PSSL=1. XRAOF output when PSSL=0. (Not used.)
58	MNT3	O	DA 04 output when PSSL=1. MNT3 output when PSSL=0.
59	MNT2	O	DA 03 output when PSSL=1. MNT2 output when PSSL=0.
60	MNT1	O	DA 02 output when PSSL=1. MNT1 output when PSSL=0.
61	MNT0	O	DA 01 output when PSSL=1. MNT0 output when PSSL=0.
62	XTAI	I	X'tal oscillator circuit input
63	XTAO	O	X'tal oscillator circuit output (Not used.)
64	XTSL	I	X'tal selection input pin (Ground)
65	DVSS	–	Digital Ground
66	FSTI	I	2/3 divider input of pins 62 and 63.
67	FSTO	O	2/3 divider output of pins 62 and 63.
68	FSOF	O	(Not used.)
69	C16M	O	16.9344MHz output (Not used.)
70	MD2	I	Digital-out ON/OFF control pin (+5V)
71	DOUT	O	Digital-out output pin
72	EMPH	O	Playback disc output in emphasis mode. (Not used.)
73	WFCK	O	WFCK output
74	SCOR	O	Sub-code sync output
75	SBSO	O	Sub-P through Sub-W serial output (Not used.)
76	EXCK	I	Clock input for SBSO read-out. (Ground)
77	SUBQ	O	Sub-Q 80-bit output
78	SQCK	I	Clock input for SQSO read-out.
79	MUTE	I	Muting selection pin
80	SENS	O	SENS output
81	XRST	I	System reset
82	DIRC	I	Used in 1-track jump mode (+5V)
83	SCLK	I	SENS serial data read-out clock
84	DFSW	I	DFCT selection pin (Ground)
85	ATSK	I	Input pin for anti-shock. (Ground)
86	DATA	I	Serial data input, supplied from CPU.
87	XLAT	I	Latch input, supplied from CPU.
88	CLOK	I	Serial data transfer clock input, supplied from CPU.
89	COUT	O	Numbers of track counted signal output. (Not used.)
90	DVDD	–	Digital power supply
91	MIRR	O	Mirror signal output
92	DFCT	O	Defect signal output
93	FOK	O	Focus OK output
94	FSW	O	Output to select spindle motor output filter. (Not used.)
95	MON	O	Output to control ON/OFF of spindle motor. (Not used.)
96	MDP	O	Output to control spindle motor servo

Pin No.	Pin Name	I/O	Function
97	MDS	O	Output to control spindle motor servo. (Not used.)
98	LOCK	O	GFS is sampled by 460Hz. H when GFS is H. (Not used.)
99	SSTP	I	Input signal to detect disc innermost track.
100	SFDR	O	Sled drive output

• IC501 CXP82612-021Q (MASTER CONTROL)

Pin No.	Pin Name	I/O	Function
1	TIMER	–	Connected to +5V.
2	RM	I	Audio bus input
3	+5V	–	Connected to +5V.
4-6	–	–	Not used. (Open)
7	PGML	O	Latch signal output to digital filter (IC201).
8	CLK	O	Serial clock output
9	SENSE	I	SENSE signal input
10	DATA	O	Serial data output
11	SQCK	O	Read out clock output for subcode Q data.
12	SUBQ	I	Subcode Q data input
13	–	–	Not used. (Open)
14	AMUTE	O	Analog muting control signal output
15	LDON	O	Optical pick-up laser diode control output
16	XLT	O	Serial data latch signal output
17	–	–	Not used. (Open)
18	RV+	–	Not used. (Open)
19	RV-	–	Not used. (Open)
20	LDOUT	O	Loading motor control signal output
21	LDIN	I	Loading motor control signal input
22	KEY0	I	Key input (S530)
23	KEY1	I	Key input (S520-S527)
24	KEY2	I	Key input (S501-S506)
25	KEY3	–	Connected to +5V.
26,27	KEY4,KEY5	I	Key input (S531)
28	ADJ/AFADJ	–	ADJ/AFJ test pin
29	IN/OUTSW	I	Loading IN/OUT switch input
30	RST	I	Reset signal input
31	EXTAL	I	Clock input (4MHz)
32	XTAL	O	Clock output (4MHz)
33	VSS	–	Ground
34-41	–	–	Not used. (Open)
42-62	S1-S21	O	FL segment output
63-70	1G-7G	O	FL grid output
71	VFDP(-30V)	–	-30V pin for FL display tube.
72	VDD(+5V)	–	+5V pin
73	+5V	–	+5V pin
74	SEL1	–	Connected to Ground.
75-77	–	–	Connected to Ground.
78	SCOR	I	Read out timing signal input for subcode Q data.
79,80	SEL2,SEL3	–	Connected to +5V.

4-2. PRINTED WIRING BOARD — BD SECTION —

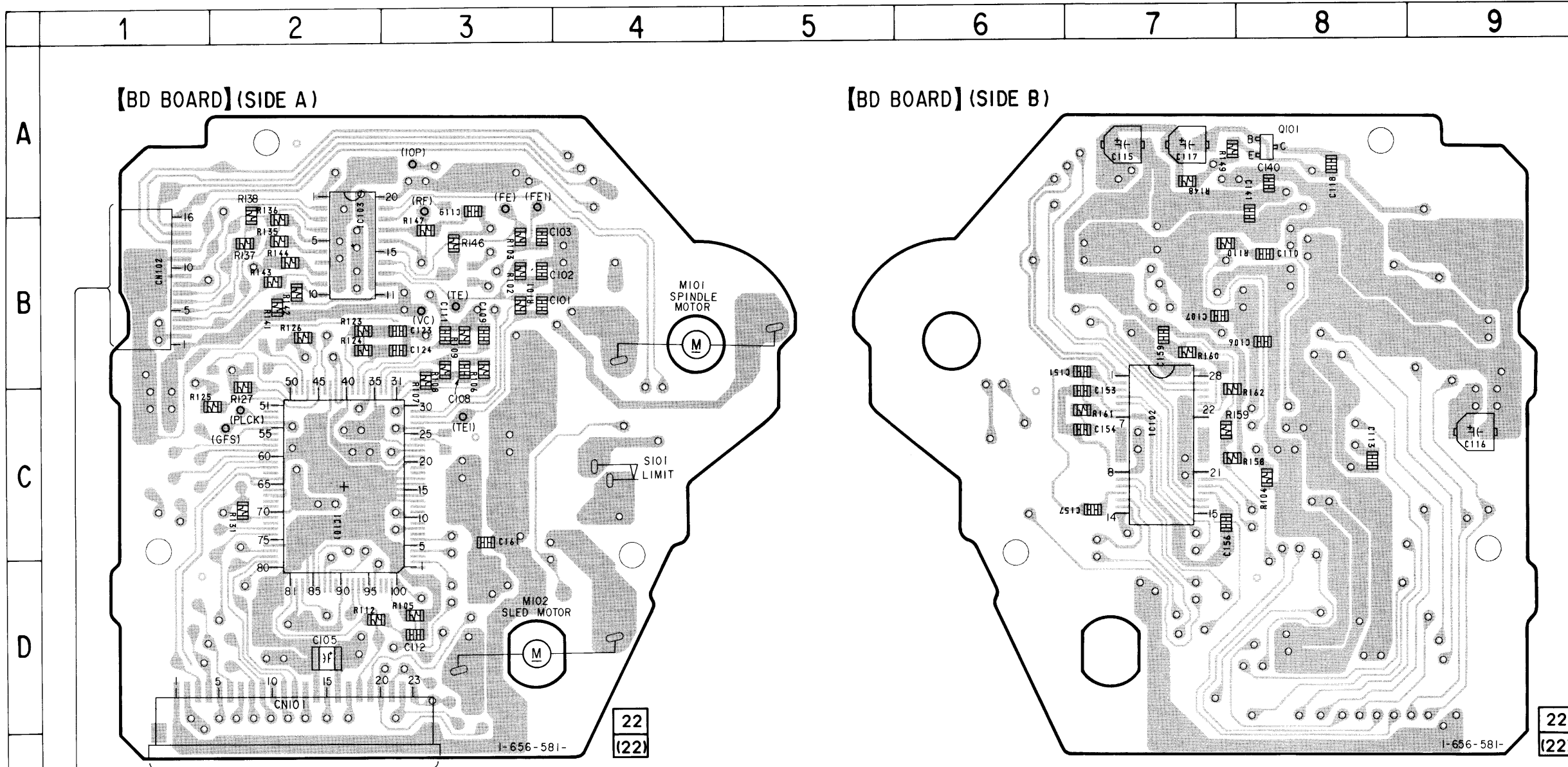

• Waveforms

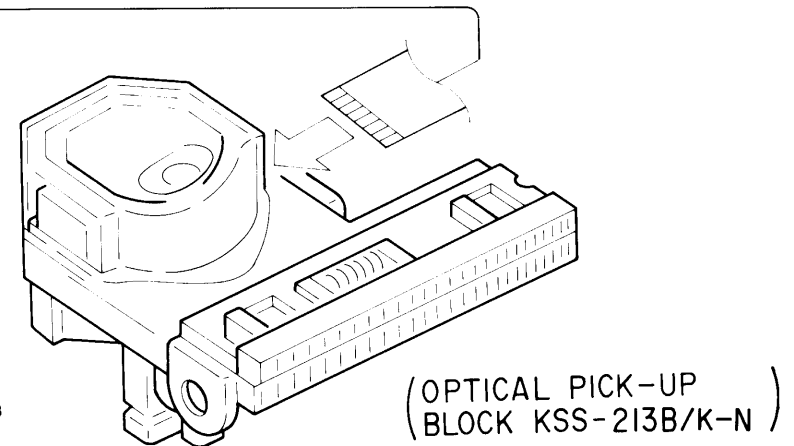
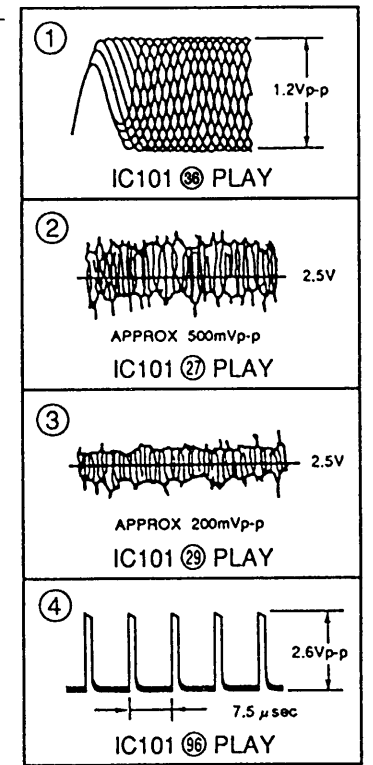

Note:
 • ○ : Through hole.
 • ■ : Pattern on the side which is seen.
 (The other layer's patterns are not indicated.)

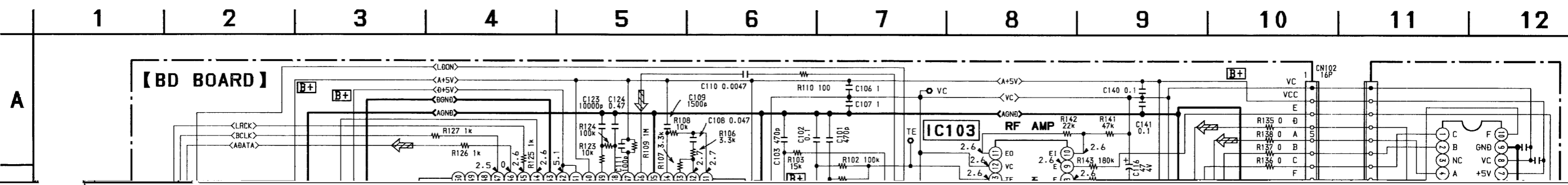

4-4. PRINTED WIRING BOARDS — MAIN SECTION —

• Semiconductor Location

Ref. No.	Location
D400	I-3
D401	I-3
D402	I-2
D403	G-2
D701	I-5
D702	I-4
D703	I-5
D704	H-5
D705	H-5
(D706)	H-5
D707	H-5
(D708)	H-5
D901	H-6
D902	H-6
D903	H-6
D904	H-6
D905	H-7
IC201	G-4
IC301	F-6
IC302	F-7
IC401	F-2
IC501	C-6
IC502	C-12
IC701	H-5
Q301	G-8
Q351	F-8
Q400	I-4
Q401	I-3
Q501	C-12
Q701	H-5
Q702	H-5

(): AEP, UK, G, EE model only

Note :

- : parts extracted from the component side.
- ▨ : Pattern on the side which is seen.
- Abbreviation
 CND : Canadian model
 G : German model
 EE : East European model
 AUS : Australian model
 CH : Chinese model

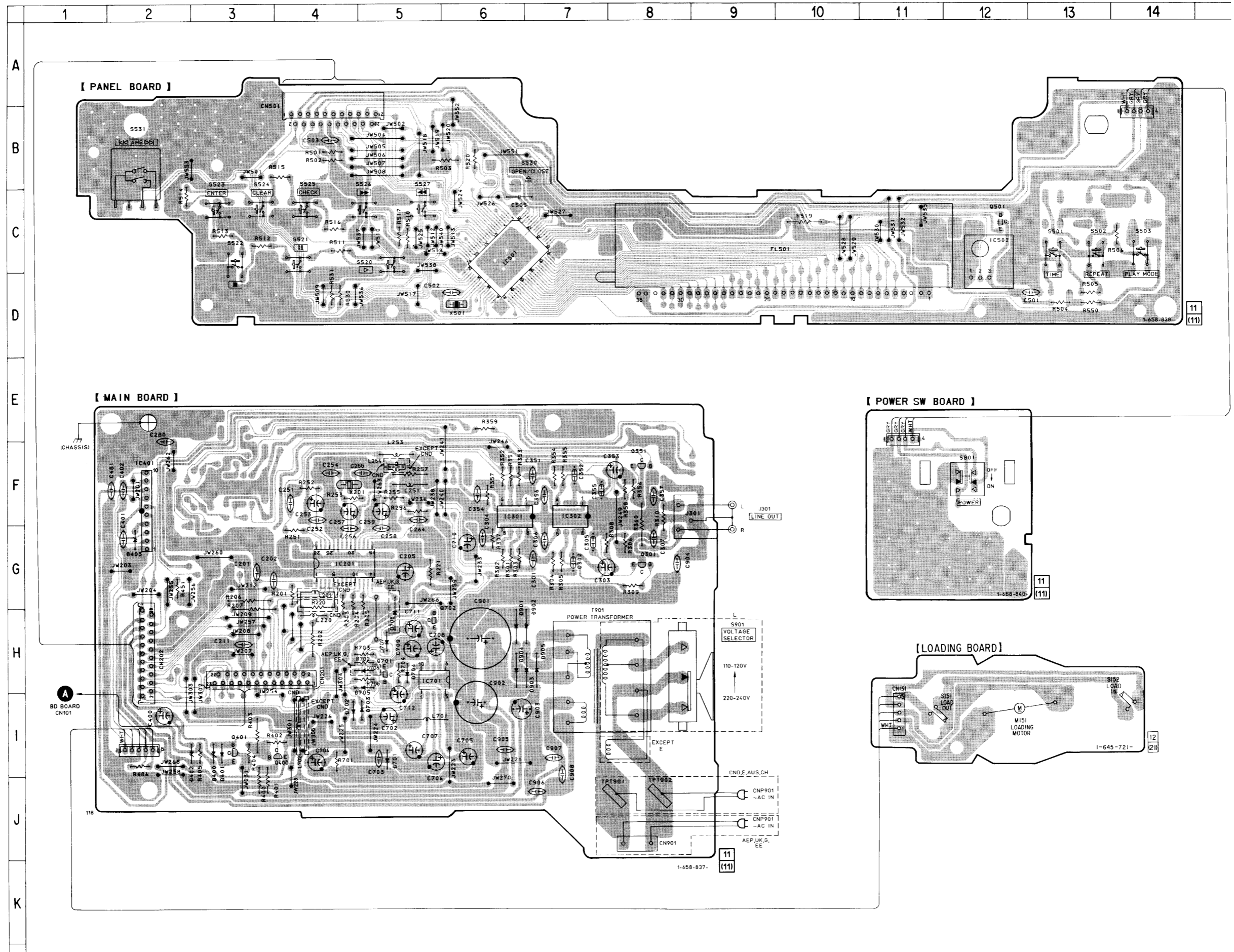

4-5. SCHEMATIC DIAGRAM — MAIN SECTION — • Refer to page 24 for IC Block Diagrams.

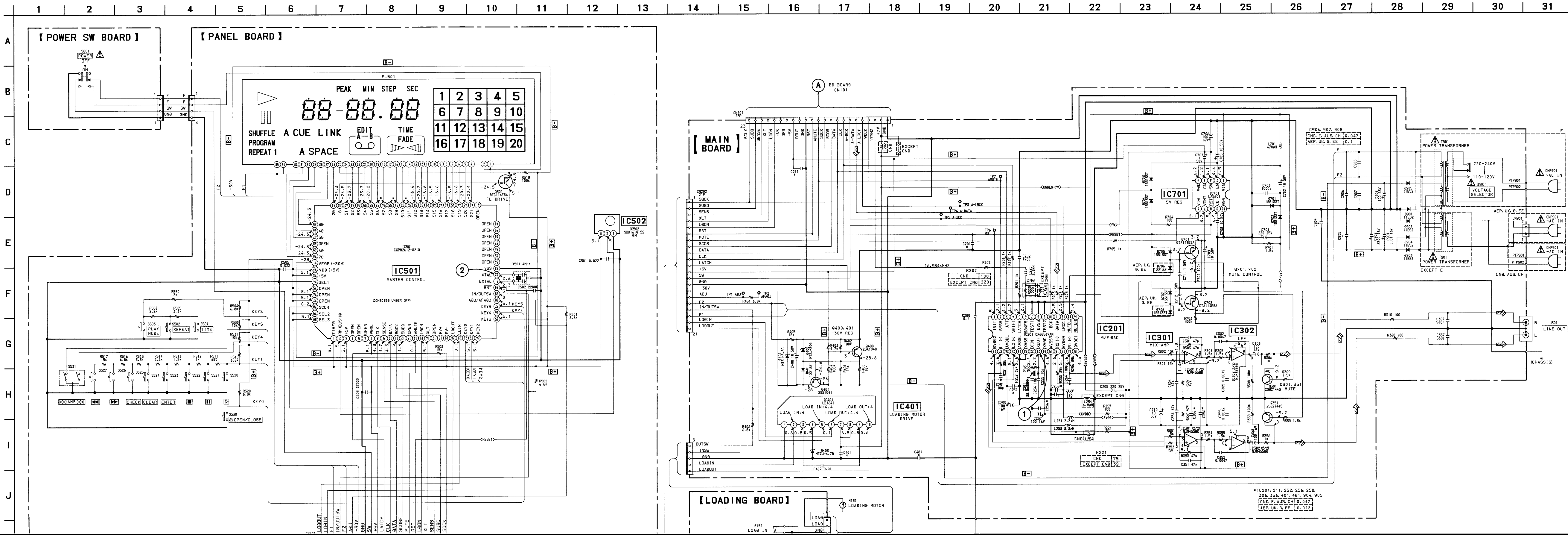

• Waveforms

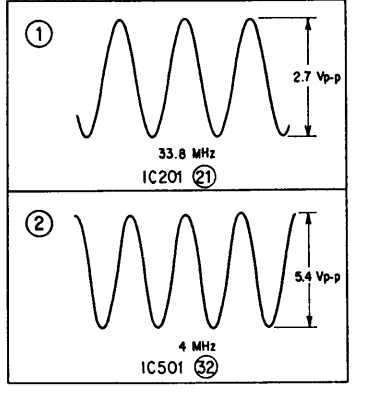

Note:

- All capacitors are in μ F unless otherwise noted. pF : μ F 50WV or less are not indicated except for electrolytics and tantalums.
- All resistors are in Ω and 1/4 W or less unless otherwise specified.
- Δ : internal component.

Note:

The components identified by mark Δ or dotted line with mark Δ are critical for safety. Replace only with part number specified.

Note:

Les composants identifiés par une marque Δ sont critiques pour la sécurité. Ne les remplacer que par une pièce portant le numéro spécifié.

- B+ : B+ Line
- B- : B- Line
- Voltage and waveforms are dc with respect to ground under no-signal conditions.
- no mark: PLAY
- \times : Impossible to measure
- Voltages are taken with a VOM (Input Impedance 10M Ω). Voltage variations may be noted due to normal production tolerances.
- Waveforms are taken with an oscilloscope. Voltage variations may be noted due to normal production tolerances.
- Circled numbers refer to waveforms.
- Signal path.
- CD : CD
- Abbreviation
 - G : German model
 - EE : East European model
 - CND : Canadian model
 - AUS : Australian model
 - CH : Chinese model

• IC Block Diagrams

IC103 CXA1821M

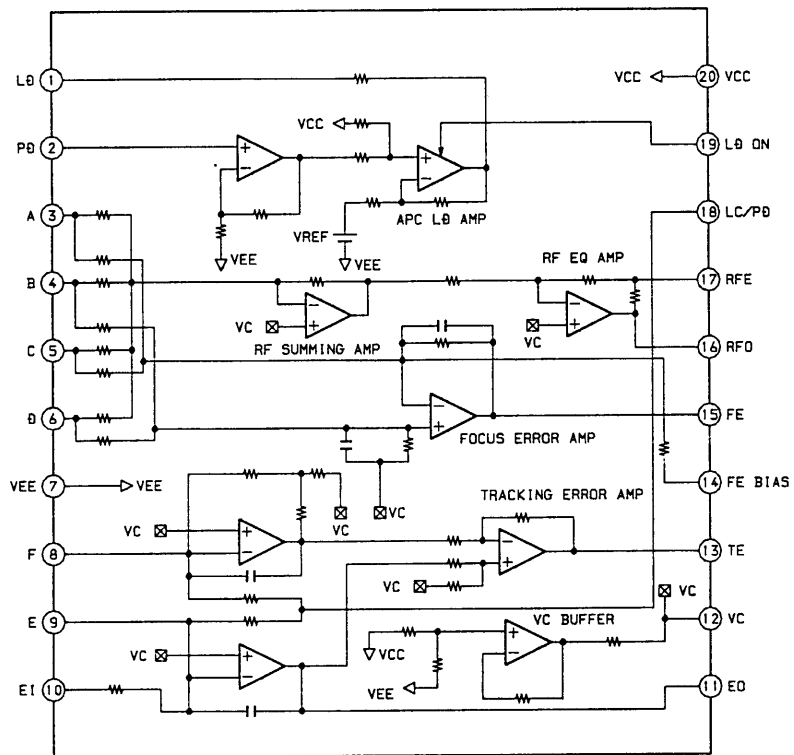

IC201 CXD8567AM

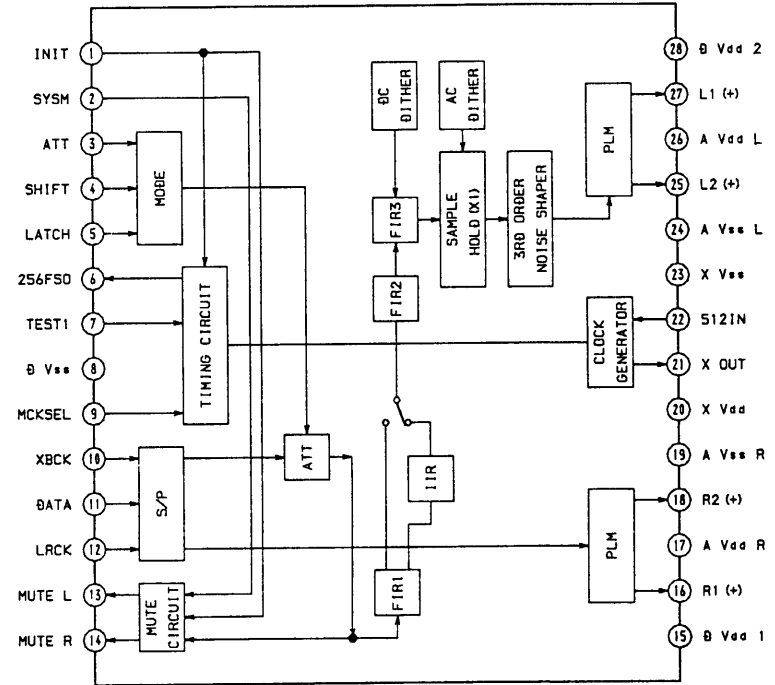

IC401 LB1641

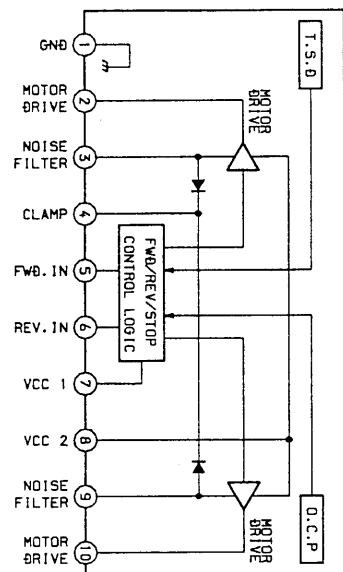

IC701 LA5601

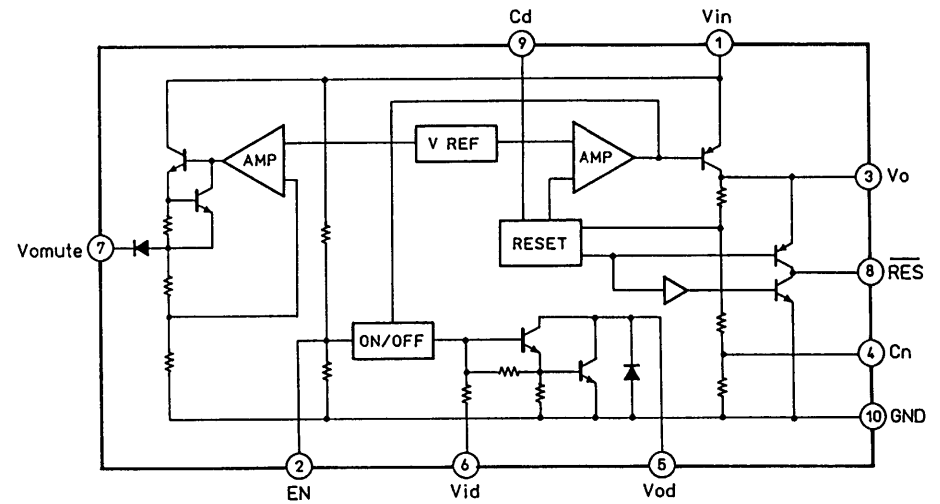

SECTION 5 EXPLODED VIEWS

NOTE:

- The mechanical parts with no reference number in the exploded views are not supplied.
- Items marked "*" are not stocked since they are seldom required for routine service. Some delay should be anticipated when ordering these items.
- Abbreviation
 CND : Canadian model
 AUS : Australian model
 CH : Chinese model
 G : German model
 EE : East European model

- -XX and -X mean standardized parts, so they may have some difference from the original one.
- Color Indication of Appearance Parts
 Example :
 KNOB, BALANCE (WHITE) ... (RED)
 Parts Color Cabinet's Color
- Hardware (# mark) list and accessories and packing materials are given in the last of this parts list.

The components identified by mark Δ or dotted line with mark Δ are critical for safety. Replace only with part number specified.

Les composants identifiés par marque Δ sont critiques pour la sécurité. Ne les remplacer que par une pièce portant le numéro spécifié.

5-1. CASE SECTION

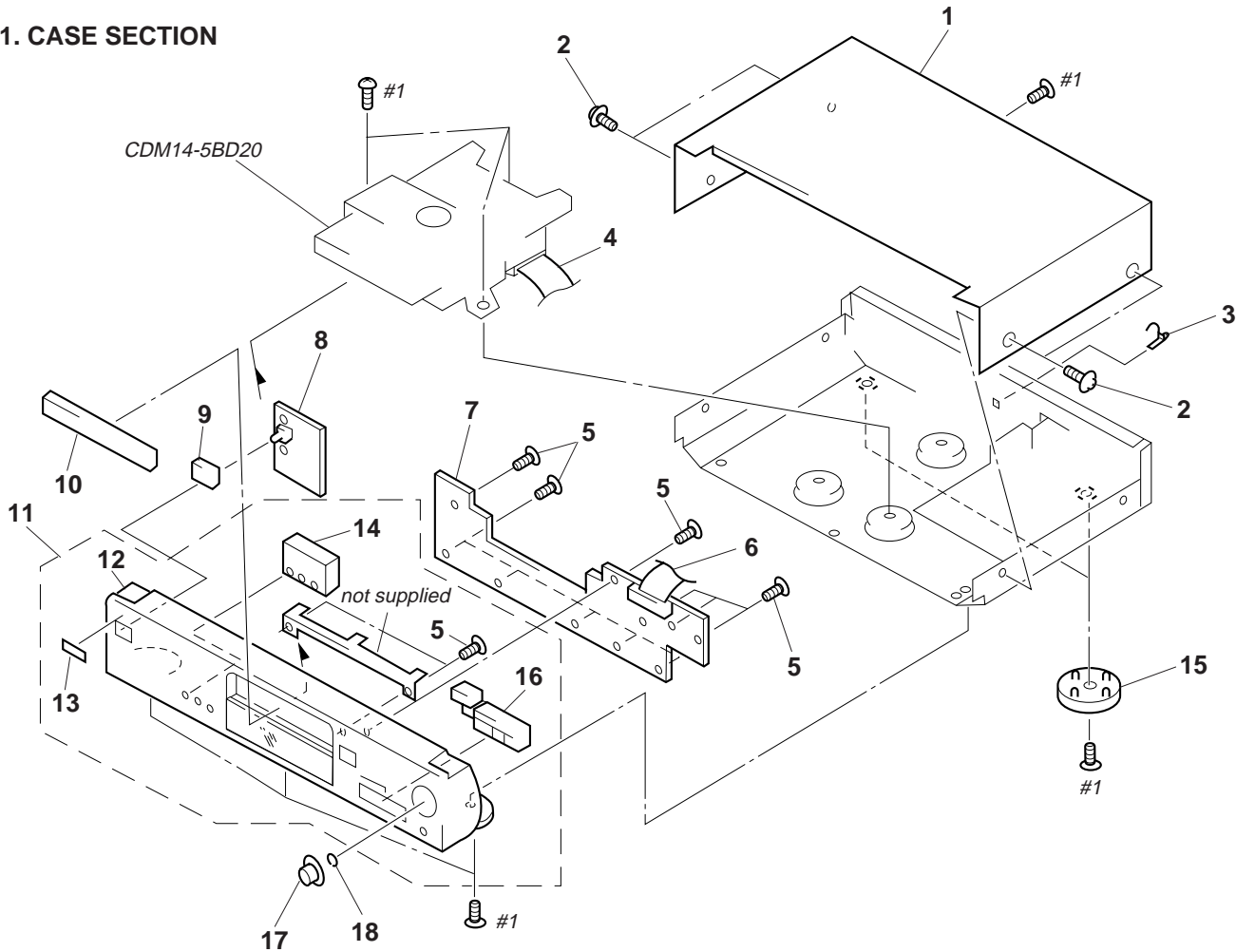

Ref. No.	Part No.	Description	Remark	Ref. No.	Part No.	Description	Remark
* 1	4-977-585-11	CASE (CND,E,AUS,CH)		11	X-4946-533-1	PANEL (FRONT) ASSY (XE300:AEP,UK,G,EE)	
* 1	4-978-901-21	CASE (408226) (AEP,UK,G,EE)		11	X-4946-825-1	PANEL (FRONT) ASSY (XE200:AEP,UK,G,EE)	
2	3-363-099-01	SCREW (CASE 3 TP2) (AEP,UK,G,EE)		12	X-4947-084-1	PANEL ASSY, FRONT (XE300:CND)	
2	3-704-366-31	SCREW (CASE) (M3X6) (CND,E,AUS,CH)		12	X-4947-107-1	PANEL ASSY, FRONT (XE200:CND,E,CH)	
3	4-956-370-02	BAND, PLUG FIXED (UK,AUS)		12	X-4947-263-1	PANEL ASSY, FRONT (XE300:AUS)	
4	1-776-100-11	WIRE (FLAT TYPE) (23 CORE)		12	X-4947-264-1	PANEL ASSY, FRONT (XE200:AUS)	
5	4-951-620-01	SCREW (2.6X8), +BVTP		13	4-963-404-21	EMBLEM (5-A), SONY (CND,E,AUS,CH)	
6	1-776-099-11	WIRE (FLAT TYPE) (21 CORE)		14	4-977-584-21	BUTTON (MODE) (CND,E,AUS,CH)	
* 7	A-4673-760-A	PANEL BOARD, COMPLETE		15	X-4947-207-1	FOOT ASSY (F50150S) (EXCEPT CND)	
* 8	1-658-840-11	POWER SW BOARD		15	X-4947-208-1	FOOT ASSY (F50150S) (CND)	
9	4-977-589-01	BUTTON (POWER)		16	4-977-583-01	BUTTON (PLAY) (CND,E,AUS,CH)	
10	4-977-588-01	PANEL, LOADING (XE300)		17	4-977-590-01	KNOB (AMS)	
10	4-977-588-11	PANEL, LOADING (XE200)		18	3-354-981-01	SPRING (SUS), RING	

5-2. BACK PANEL SECTION

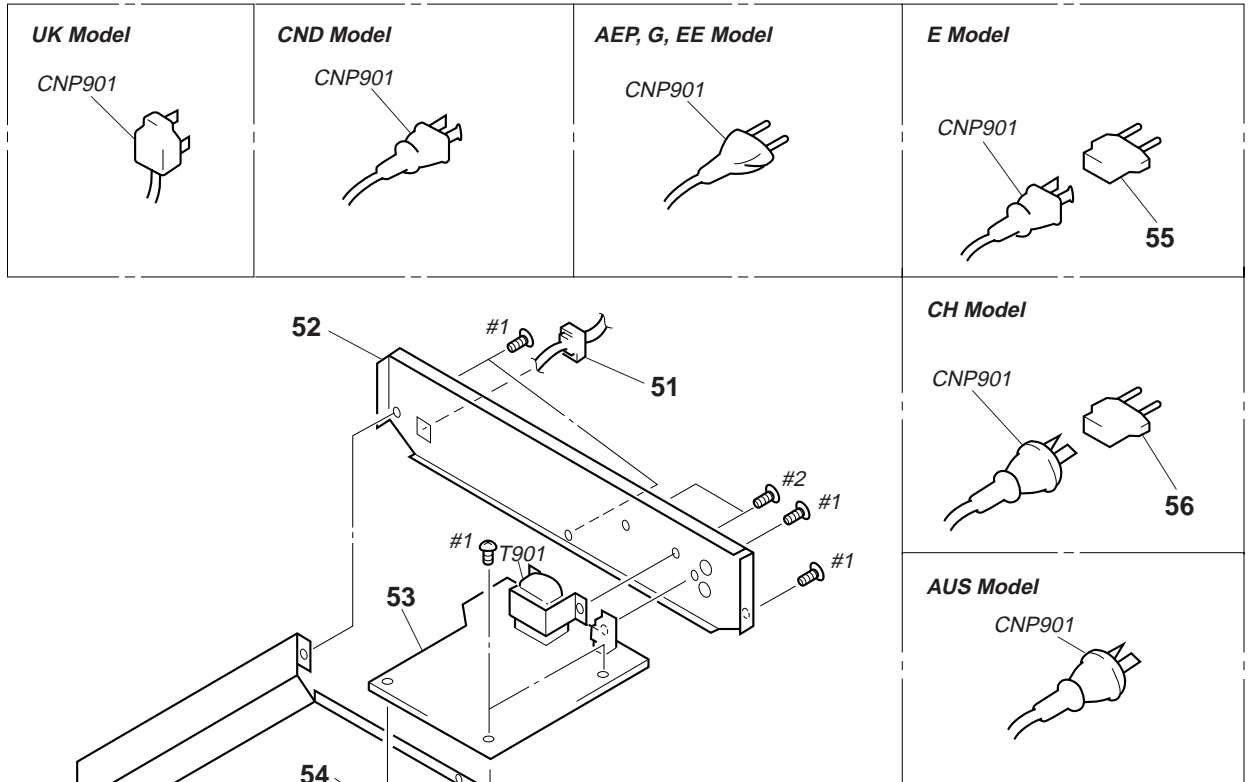

The components identified by mark \triangle or dotted line with mark \triangle are critical for safety. Replace only with part number specified.

Les composants identifiés par une marque \triangle sont critiques pour la sécurité. Ne les remplacer que par une pièce portant le numéro spécifié.

Ref. No.	Part No.	Description	Remark	Ref. No.	Part No.	Description	Remark
	51	3-703-244-00 BUSHING, CORD (EXCEPT CND,E)		* 54	4-954-051-51	HOLDER, PC BOARD	
* 51	3-703-571-11	BUSHING (S) (4516), CORD (CND,E)		\triangle 55	1-569-007-11	ADAPTOR, CONVERSION 2P (E)	
* 52	4-978-388-21	PANEL, BACK (XE300:AEP,G,EE)		\triangle 56	1-569-008-11	ADAPTOR, CONVERSION 2P (CH)	
* 52	4-978-388-31	PANEL, BACK (XE300:UK)		\triangle CNP901	1-558-943-81	CORD, POWER (E)	
* 52	4-978-388-41	PANEL, BACK (XE200:CND)		\triangle CNP901	1-558-945-21	CORD, POWER (POLAR.SPT-1) (CND)	
* 52	4-978-388-51	PANEL, BACK (XE200:AUS)		\triangle CNP901	1-575-651-21	CORD, POWER (AEP,G,EE)	
* 52	4-978-388-61	PANEL, BACK (XE300:AUS)		\triangle CNP901	1-696-845-11	CORD, POWER (AUS)	
* 52	4-978-388-81	PANEL, BACK (XE300:CND)		\triangle CNP901	1-696-907-11	CORD, POWER (UK)	
* 52	4-978-388-91	PANEL, BACK (E)		\triangle CNP901	1-696-966-11	CORD, POWER (CH)	
* 52	4-979-971-01	PANEL, BACK (CH)		\triangle T901	1-423-979-11	TRANSFORMER, POWER (EXCEPT CND,E)	
* 52	4-979-971-11	PANEL, BACK (XE200:UK)		\triangle T901	1-426-621-11	TRANSFORMER, POWER (CND)	
* 52	4-979-971-21	PANEL, BACK (XE200:AEP,G,EE)		\triangle T901	1-426-622-11	TRANSFORMER, POWER (E)	
* 53	A-4673-743-A	MAIN BOARD, COMPLETE (CND)					
* 53	A-4673-744-A	MAIN BOARD, COMPLETE (E)					
* 53	A-4673-745-A	MAIN BOARD, COMPLETE (EXCEPT CND,E)					

**5-3. CD MECHANISM SECTION
(CDM14-5BD20)**

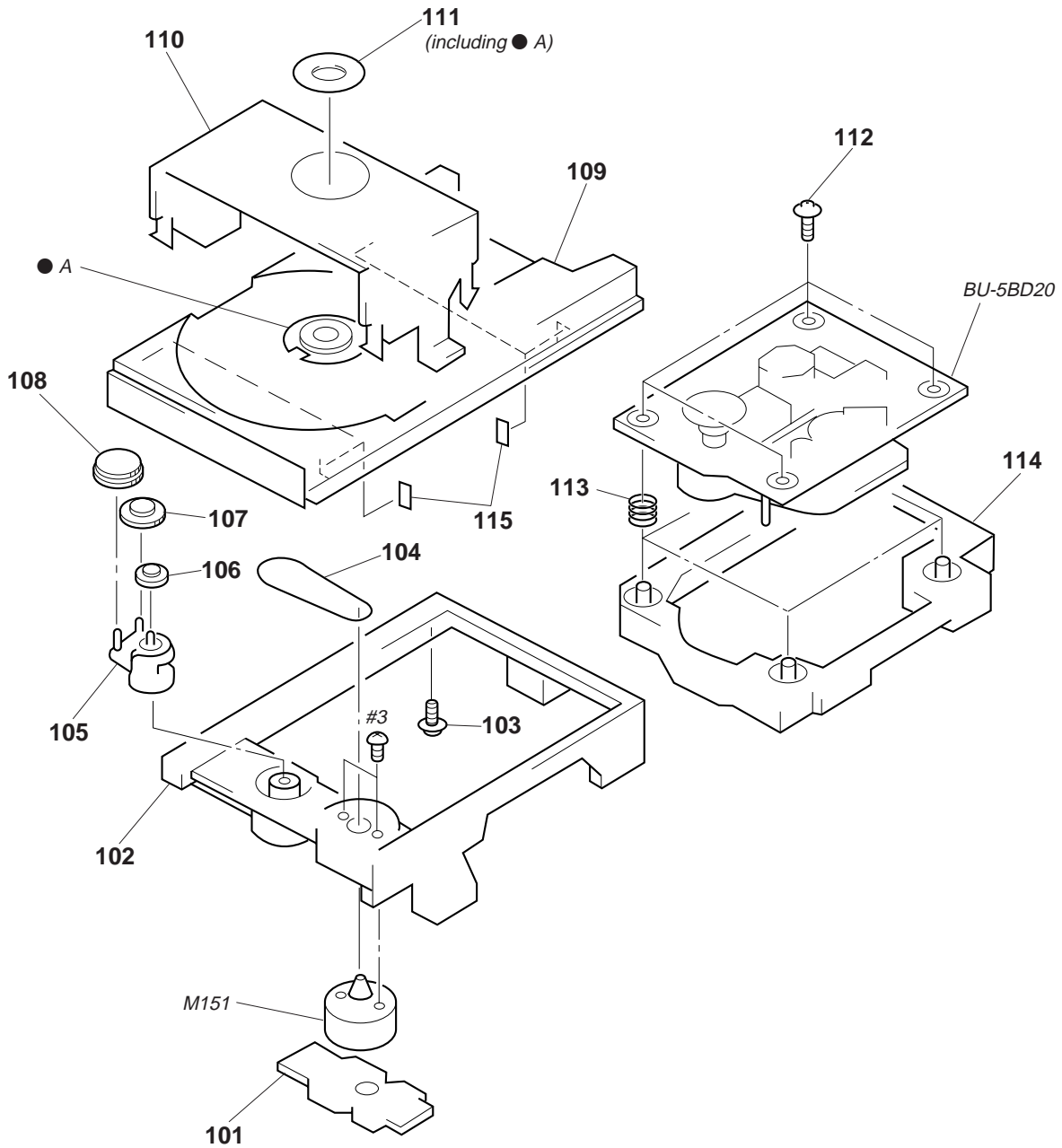

Ref. No.	Part No.	Description	Remark	Ref. No.	Part No.	Description	Remark
* 101	1-645-721-11	LOADING BOARD		110	4-933-110-41	HOLDER (MG)	
102	4-933-111-11	CHASSIS (MD)		* 111	1-452-538-11	MAGNET (AEP,UK,G,EE)	
* 103	4-917-583-21	BRACKET, YOKE		111	1-452-538-41	MAGNET (CND,E,AUS,CH)	
104	4-927-649-01	BELT		112	4-933-134-01	SCREW (+PTPWH M2.6X6)	
105	4-933-109-01	CAM		113	4-959-996-01	SPRING (932), COMPRESSION	
106	4-927-651-01	PULLEY (S)		114	4-933-129-01	HOLDER (BU)	
107	4-967-268-01	GEAR (C)		115	4-925-315-31	DAMPER	
108	4-933-107-01	GEAR (PL)		M151	A-4604-363-A	MOTOR (L) ASSY (LOADING)	
109	4-933-112-11	TABLE, DISC					

**5-4. BASE UNIT SECTION
(BU-5BD20)**

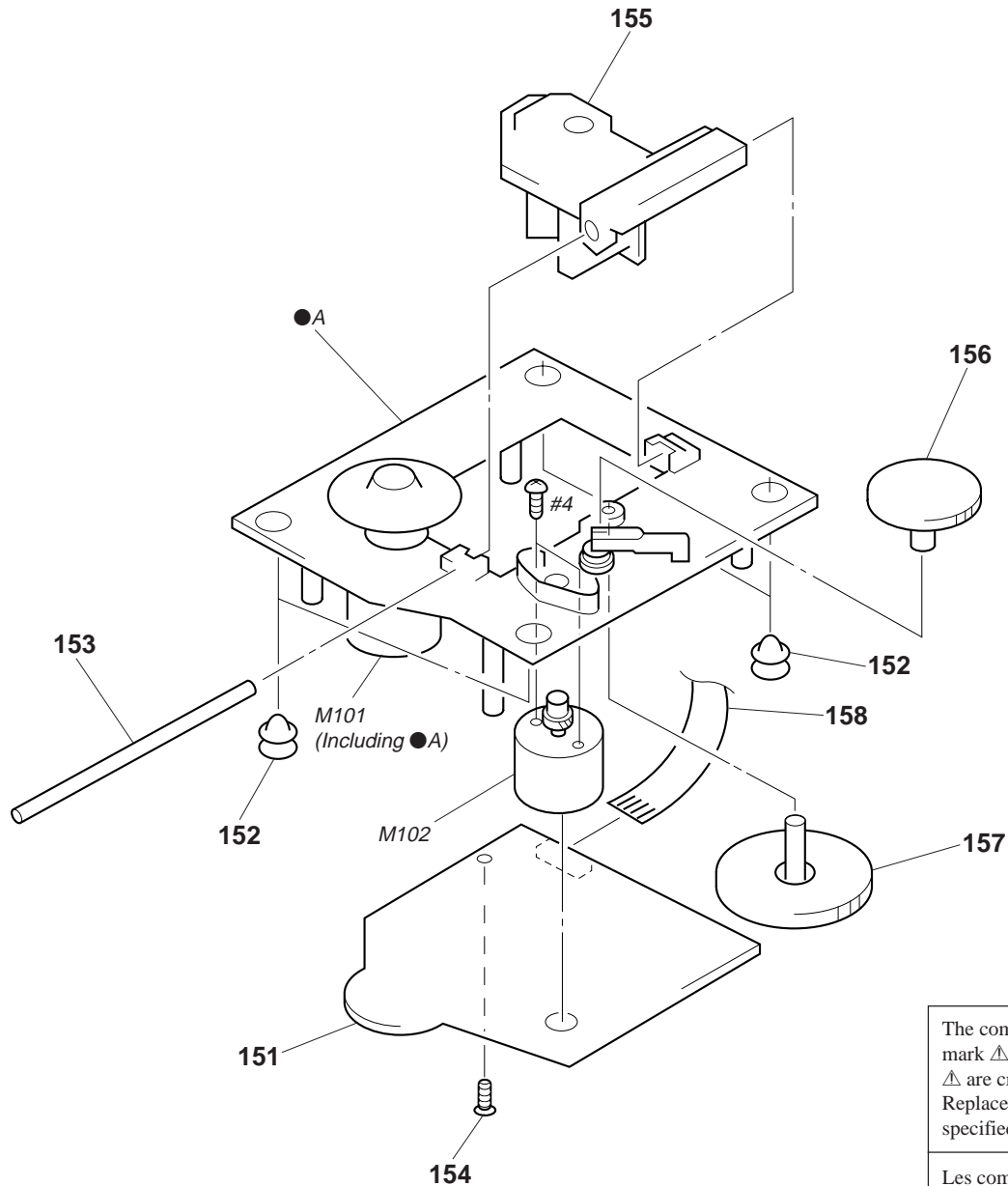

The components identified by mark \triangle or dotted line with mark \triangle are critical for safety. Replace only with part number specified.

Les composants identifiés par une marque \triangle sont critiques pour la sécurité. Ne les remplacer que par une pièce portant le numéro spécifié.

Ref. No.	Part No.	Description	Remark	Ref. No.	Part No.	Description	Remark
* 151	A-4673-509-A	BD BOARD, COMPLETE (CND,E,AUS,CH)		156	4-917-567-21	GEAR (M)	
* 151	A-4673-511-A	BD BOARD, COMPLETE (AEP,UK,G,EE)		157	4-917-564-01	GEAR (P), FLATNESS	
152	4-951-940-01	INSULATOR (BU)		158	1-769-069-11	WIRE (FLAT TYPE) (16 CORE)	
153	4-917-565-01	SHAFT, SLED		M101	X-4917-523-3	BASE (OUTSERT) ASSY (SPINDLE)	
154	4-951-620-01	SCREW (2.6X8), +BVTP		M102	X-4917-504-1	MOTOR ASSY (SLED)	
\triangle 155	8-848-379-31	PICK-UP BLOCK, OPTICAL KSS-213BA/F-NP					

SECTION 6 ELECTRICAL PARTS LIST

NOTE:

- Due to standardization, replacements in the parts list may be different from the parts specified in the diagrams or the components used on the set.
- -XX and -X mean standardized parts, so they may have some difference from the original one.
- RESISTORS
All resistors are in ohms.
METAL: Metal-film resistor.
METAL OXIDE: Metal oxide-film resistor.
F: nonflammable
- Abbreviation
CND: Canadian model
AUS: Australian model
CH: Chinese model
G: German model
EE: East European model

- Items marked "*" are not stocked since they are seldom required for routine service. Some delay should be anticipated when ordering these items.
- SEMICONDUCTORS
In each case, u: μ , for example:
uA.: μ A. uPA.: μ PA..
uPB.: μ PB. uPC.: μ PC. uPD.: μ PD..
- CAPACITORS
uF: μ F
- COILS
uH: μ H

The components identified by mark \triangle or dotted line with mark. \triangle are critical for safety.
Replace only with part number specified.

Les composants identifiés par une marque \triangle sont critiques pour la sécurité.
Ne les remplacer que par une pièce portant le numéro spécifié.

When indicating parts by reference number, please include the board.

Ref. No.	Part No.	Description	Remark	Ref. No.	Part No.	Description	Remark
*	A-4673-509-A	BD BOARD, COMPLETE (CND,E,AUS,CH)				< IC >	
*	A-4673-511-A	BD BOARD, COMPLETE (AEP,UK,G,EE)					

		< CAPACITOR >					
C101	1-163-005-11	CERAMIC CHIP	470PF	10%	50V		
C102	1-163-038-00	CERAMIC CHIP	0.1uF		25V		
C103	1-163-005-11	CERAMIC CHIP	470PF	10%	50V		
C105	1-135-155-21	TANTALUM CHIP	4.7uF	10%	16V		
C106	1-164-346-11	CERAMIC CHIP	1uF		16V		
C107	1-164-346-11	CERAMIC CHIP	1uF		16V		
C108	1-163-035-00	CERAMIC CHIP	0.047uF		50V		
C109	1-163-145-00	CERAMIC CHIP	0.0015uF	5%	50V		
C110	1-163-017-00	CERAMIC CHIP	0.0047uF	5%	50V		
C111	1-163-251-11	CERAMIC CHIP	100PF	5%	50V		
C112	1-163-038-00	CERAMIC CHIP	0.1uF		25V		
C113	1-163-038-00	CERAMIC CHIP	0.1uF		25V		
C115	1-126-607-11	ELECT CHIP	47uF	20%	4V		
C116	1-126-607-11	ELECT CHIP	47uF	20%	4V		
C117	1-126-209-11	ELECT	100uF	20%	4V		
C118	1-163-275-11	CERAMIC CHIP	0.001uF	5%	50V		
C119	1-163-231-11	CERAMIC CHIP	15PF	5%	50V		
C123	1-164-232-11	CERAMIC CHIP	0.01uF		50V		
C124	1-164-005-11	CERAMIC CHIP	0.47uF		25V		
C140	1-163-038-00	CERAMIC CHIP	0.1uF		25V		
C141	1-163-038-00	CERAMIC CHIP	0.1uF		25V		
C151	1-163-237-11	CERAMIC CHIP	27PF	5%	50V		
C153	1-163-038-00	CERAMIC CHIP	0.1uF		25V		
C154	1-164-336-11	CERAMIC CHIP	0.33uF		25V		
C156	1-163-237-11	CERAMIC CHIP	27PF	5%	50V		
C157	1-163-145-00	CERAMIC CHIP	0.0015uF	5%	50V		
C159	1-163-019-00	CERAMIC CHIP	0.0068uF	10%	50V		
C161	1-163-038-00	CERAMIC CHIP	0.1uF		25V		
		< CONNECTOR >					
CN101	1-770-072-11	CONNECTOR, FFC 23P					
CN102	1-770-014-11	CONNECTOR, FFC/FPC 16P					
IC101	8-752-369-78	IC CXD2545Q					
IC102	8-759-176-09	IC BA6392FP					
IC103	8-752-072-45	IC CXA1821M-T6					
		< TRANSISTOR >					
Q101	8-729-010-08	TRANSISTOR MSB710-R					
		< RESISTOR >					
R101	1-216-077-00	METAL CHIP	15K	5%	1/10W		
R102	1-216-097-00	METAL GLAZE	100K	5%	1/10W		
R103	1-216-077-00	METAL CHIP	15K	5%	1/10W		
R104	1-216-085-00	METAL CHIP	33K	5%	1/10W		
R105	1-216-097-00	METAL GLAZE	100K	5%	1/10W		
R106	1-216-061-00	METAL CHIP	3.3K	5%	1/10W		
R107	1-216-061-00	METAL CHIP	3.3K	5%	1/10W		
R108	1-216-073-00	METAL CHIP	10K	5%	1/10W		
R109	1-216-121-00	METAL GLAZE	1M	5%	1/10W		
R110	1-216-025-00	METAL GLAZE	100	5%	1/10W		
R112	1-216-049-11	METAL GLAZE	1K	5%	1/10W		
R123	1-216-073-00	METAL CHIP	10K	5%	1/10W		
R124	1-216-097-00	METAL GLAZE	100K	5%	1/10W		
R125	1-216-049-11	METAL GLAZE	1K	5%	1/10W		
R126	1-216-049-11	METAL GLAZE	1K	5%	1/10W		
R127	1-216-049-11	METAL GLAZE	1K	5%	1/10W		
R131	1-216-037-00	METAL CHIP	330	5%	1/10W		
R135	1-216-295-00	CONDUCTOR, CHIP			(2012)		
R136	1-216-295-00	CONDUCTOR, CHIP			(2012)		
R137	1-216-295-00	CONDUCTOR, CHIP			(2012)		
R138	1-216-295-00	CONDUCTOR, CHIP			(2012)		
R141	1-216-089-00	METAL GLAZE	47K	5%	1/10W		
R142	1-216-081-00	METAL CHIP	22K	5%	1/10W		
R143	1-216-103-00	METAL GLAZE	180K	5%	1/10W		
R144	1-216-103-00	METAL GLAZE	180K	5%	1/10W		
R146	1-216-073-00	METAL CHIP	10K	5%	1/10W		
R147	1-216-081-00	METAL CHIP	22K	5%	1/10W		

Ref. No.	Part No.	Description	Remark	Ref. No.	Part No.	Description	Remark
R148	1-216-001-00	METAL CHIP	10 5% 1/10W	C257	1-126-933-11	ELECT	100uF 20% 16V
R149	1-216-003-11	METAL GLAZE	12 5% 1/10W	C258	1-101-006-00	CERAMIC	0.047uF 50V
R158	1-216-111-00	METAL GLAZE	390K 5% 1/10W				(CND,E,AUS,CH)
R159	1-216-101-00	METAL CHIP	150K 5% 1/10W	C258	1-161-494-00	CERAMIC	0.022uF 25V
R160	1-216-295-00	CONDUCTOR, CHIP	(2012)				(AEP,UK,G,EE)
R161	1-216-308-00	METAL CHIP	4.7 5% 1/10W	C259	1-126-933-11	ELECT	100uF 20% 16V
R162	1-216-101-00	METAL CHIP	150K 5% 1/10W	C264	1-162-282-31	CERAMIC	100PF 10% 50V
		< SWITCH >		C280	1-164-159-21	CERAMIC	0.1uF 50V
S101	1-572-085-11	SWITCH, LEAF (LIMIT SW)		C301	1-162-215-31	CERAMIC	47PF 5% 50V
*****				C302	1-130-479-00	MYLAR	0.0047uF 5% 50V
*	1-645-721-11	LOADING BOARD		C303	1-126-933-11	ELECT	100uF 20% 16V
		*****		C304	1-162-215-31	CERAMIC	47PF 5% 50V
		< CONNECTOR >		C305	1-130-472-00	MYLAR	0.0012uF 5% 50V
* CN151	1-568-943-11	PIN, CONNECTOR 5P		C306	1-101-006-00	CERAMIC	0.047uF 50V
		< SWITCH >					(CND,E,AUS,CH)
S151	1-572-086-11	SWITCH, LEAF (LOAD OUT)		C306	1-161-494-00	CERAMIC	0.022uF 25V
S152	1-572-086-11	SWITCH, LEAF (LOAD IN)					(AEP,UK,G,EE)
*****				C307	1-162-291-31	CERAMIC	560PF 10% 50V
*	A-4673-743-A	MAIN BOARD, COMPLETE (CND)		C351	1-162-215-31	CERAMIC	47PF 5% 50V
*	A-4673-744-A	MAIN BOARD, COMPLETE (E)					
*	A-4673-745-A	MAIN BOARD, COMPLETE (EXCEPT CND,E)		C352	1-130-479-00	MYLAR	0.0047uF 5% 50V
		*****		C353	1-126-933-11	ELECT	100uF 20% 16V
		< CAPACITOR >		C354	1-162-215-31	CERAMIC	47PF 5% 50V
C201	1-101-006-00	CERAMIC	0.047uF 50V	C355	1-130-472-00	MYLAR	0.0012uF 5% 50V
			(CND,E,AUS,CH)	C356	1-101-006-00	CERAMIC	0.047uF 50V
C201	1-161-494-00	CERAMIC	0.022uF 25V				(CND,E,AUS,CH)
			(AEP,UK,G,EE)	C356	1-161-494-00	CERAMIC	0.022uF 25V
C202	1-162-290-31	CERAMIC	470PF 10% 50V				(AEP,UK,G,EE)
C205	1-104-666-11	ELECT	220uF 20% 25V	C357	1-162-291-31	CERAMIC	560PF 10% 50V
C211	1-101-006-00	CERAMIC	0.047uF 50V	C400	1-126-964-11	ELECT	10uF 20% 50V
			(CND,E,AUS,CH)	C401	1-101-006-00	CERAMIC	0.047uF 50V
C211	1-161-494-00	CERAMIC	0.022uF 25V				(CND,E,AUS,CH)
			(AEP,UK,G,EE)	C401	1-161-494-00	CERAMIC	0.022uF 25V
C251	1-162-282-31	CERAMIC	100PF 10% 50V				(AEP,UK,G,EE)
C252	1-101-006-00	CERAMIC	0.047uF 50V	C402	1-162-306-11	CERAMIC	0.01uF 30% 16V
			(CND,E,AUS,CH)	C481	1-101-006-00	CERAMIC	0.047uF 50V
C252	1-161-494-00	CERAMIC	0.022uF 25V				(CND,E,AUS,CH)
			(AEP,UK,G,EE)	C481	1-161-494-00	CERAMIC	0.022uF 25V
C253	1-126-933-11	ELECT	100uF 20% 16V				(AEP,UK,G,EE)
C254	1-162-199-31	CERAMIC	10PF 5% 50V	C702	1-126-964-11	ELECT	10uF 20% 50V
C255	1-162-199-31	CERAMIC	10PF 5% 50V	C703	1-162-294-31	CERAMIC	0.001uF 10% 50V
C256	1-101-006-00	CERAMIC	0.047uF 50V				
			(CND,E,AUS,CH)	C704	1-104-666-11	ELECT	220uF 20% 25V
C256	1-161-494-00	CERAMIC	0.022uF 25V	C705	1-126-964-11	ELECT	10uF 20% 50V
			(AEP,UK,G,EE)	C706	1-126-933-11	ELECT	100uF 20% 16V
				C707	1-124-903-11	ELECT	1uF 20% 50V
				C708	1-126-964-11	ELECT	10uF 20% 50V
				C709	1-126-964-11	ELECT	10uF 20% 50V
				C710	1-126-964-11	ELECT	10uF 20% 50V
				C711	1-124-903-11	ELECT	1uF 20% 50V
				C712	1-124-903-11	ELECT	1uF 20% 50V
				C901	1-126-939-11	ELECT	10000uF 20% 16V

MAIN

Ref. No.	Part No.	Description	Remark	Ref. No.	Part No.	Description	Remark
C902	1-126-768-11	ELECT	2200uF 20% 16V	IC301	8-759-634-51	IC M5218AP	
C903	1-128-576-11	ELECT	100uF 20% 63V	IC302	8-759-634-51	IC M5218AP	
C904	1-101-006-00	CERAMIC	0.047uF 50V (CND,E,AUS,CH)	IC401	8-759-822-09	IC LB1641	
C904	1-161-494-00	CERAMIC	0.022uF 25V (AEP,UK,G,EE)	IC701	8-759-821-93	IC LA5601	
C905	1-101-006-00	CERAMIC	0.047uF 50V (CND,E,AUS,CH)			<JACK>	
C905	1-161-494-00	CERAMIC	0.022uF 25V (AEP,UK,G,EE)	J301	1-770-719-11	JACK, PIN 2P (LINE OUT)	
C906	1-101-006-00	CERAMIC	0.047uF 50V (CND,E,AUS,CH)			< COIL >	
C906	1-164-159-21	CERAMIC	0.1uF 50V (AEP,UK,G,EE)	L201	1-410-322-11	INDUCTOR 3.3uH (EXCEPT CND)	
C907	1-101-006-00	CERAMIC	0.047uF 50V (CND,E,AUS,CH)	L220	1-410-322-11	INDUCTOR 3.3uH	
C907	1-164-159-21	CERAMIC	0.1uF 50V (AEP,UK,G,EE)	L251	1-410-322-11	INDUCTOR 3.3uH	
C908	1-101-006-00	CERAMIC	0.047uF 50V (CND,E,AUS,CH)	L253	1-410-322-11	INDUCTOR 3.3uH	
C908	1-164-159-21	CERAMIC	0.1uF 50V (AEP,UK,G,EE)	L254	1-410-397-21	FERRITE BEAD INDUCTOR 1.1uH (CND)	
		< CONNECTOR >		L254	1-410-507-11	INDUCTOR 6.8uH (EXCEPT CND)	
* CN201	1-568-839-11	SOCKET, CONNECTOR 23P		L701	1-414-223-11	INDUCTOR 470uH	
CN202	1-568-838-11	SOCKET, CONNECTOR 21P		L702	1-412-473-21	INDUCTOR 0uH (CND)	
CN901	1-580-230-11	PIN, CONNECTOR (PC BOARD) 2P (AEP,UK,G,EE)				< TRANSISTOR >	
		< DIODE >		Q301	8-729-922-37	TRANSISTOR 2SD2144S	
D400	8-719-982-22	DIODE MTZJ-30D		Q351	8-729-922-37	TRANSISTOR 2SD2144S	
D401	8-719-991-33	DIODE 1SS133T-77		Q400	8-729-119-76	TRANSISTOR 2SA1175-HFE	
D402	8-719-109-97	DIODE RD6.8ES-B2		Q401	8-729-019-64	TRANSISTOR 2SB1041	
D403	8-719-010-34	DIODE UZ-4.7BSC		Q701	8-729-029-56	TRANSISTOR DTA144ESA	
D701	8-719-991-33	DIODE 1SS133T-77		Q702	8-729-029-56	TRANSISTOR DTA144ESA	
D702	8-719-991-33	DIODE 1SS133T-77				< RESISTOR >	
D703	8-719-991-33	DIODE 1SS133T-77		R201	1-249-417-11	CARBON 1K 5% 1/4W	
D704	8-719-991-33	DIODE 1SS133T-77		R202	1-247-807-00	CARBON 100 5% 1/4W (CND)	
D705	8-719-991-33	DIODE 1SS133T-77		R202	1-247-815-00	CARBON 220 5% 1/4W (EXCEPT CND)	
D706	8-719-991-33	DIODE 1SS133T-77 (AEP,UK,G,EE)		R203	1-249-417-11	CARBON 1K 5% 1/4W	
D707	8-719-991-33	DIODE 1SS133T-77		R204	1-249-417-11	CARBON 1K 5% 1/4W	
D708	8-719-991-33	DIODE 1SS133T-77 (AEP,UK,G,EE)		R205	1-249-417-11	CARBON 1K 5% 1/4W	
D901	8-719-200-82	DIODE 11ES2		R206	1-249-417-11	CARBON 1K 5% 1/4W	
D902	8-719-200-82	DIODE 11ES2		R207	1-249-417-11	CARBON 1K 5% 1/4W	
D903	8-719-200-82	DIODE 11ES2		R208	1-249-417-11	CARBON 1K 5% 1/4W	
D904	8-719-200-82	DIODE 11ES2		R220	1-247-815-00	CARBON 220 5% 1/4W (CND)	
D905	8-719-200-82	DIODE 11ES2		R221	1-247-804-11	CARBON 75 5% 1/4W (CND)	
		< IC >		R221	1-249-400-11	CARBON 39 5% 1/4W (EXCEPT CND)	
IC201	8-759-362-47	IC CXD8567AM		R251	1-249-436-11	CARBON 39K 5% 1/4W	
				R252	1-249-436-11	CARBON 39K 5% 1/4W	
				R253	1-249-424-11	CARBON 3.9K 5% 1/4W	
				R255	1-249-436-11	CARBON 39K 5% 1/4W	
				R256	1-249-436-11	CARBON 39K 5% 1/4W	
				R257	1-247-807-00	CARBON 100 5% 1/4W	
				R301	1-249-431-11	CARBON 15K 5% 1/4W	
				R302	1-249-431-11	CARBON 15K 5% 1/4W	

Ref. No.	Part No.	Description	Remark
R303	1-249-437-11	CARBON 47K 5%	1/4W
R304	1-249-419-11	CARBON 1.5K 5%	1/4W
R305	1-249-419-11	CARBON 1.5K 5%	1/4W
R306	1-249-417-11	CARBON 1K 5%	1/4W
R307	1-249-437-11	CARBON 47K 5%	1/4W
R308	1-249-441-11	CARBON 100K 5%	1/4W
R309	1-249-419-11	CARBON 1.5K 5%	1/4W
R310	1-247-807-00	CARBON 100 5%	1/4W
R351	1-249-431-11	CARBON 15K 5%	1/4W
R352	1-249-431-11	CARBON 15K 5%	1/4W
R353	1-249-437-11	CARBON 47K 5%	1/4W
R354	1-249-419-11	CARBON 1.5K 5%	1/4W
R355	1-249-419-11	CARBON 1.5K 5%	1/4W
R356	1-249-417-11	CARBON 1K 5%	1/4W
R357	1-249-437-11	CARBON 47K 5%	1/4W
R358	1-249-441-11	CARBON 100K 5%	1/4W
R359	1-249-419-11	CARBON 1.5K 5%	1/4W
R360	1-247-807-00	CARBON 100 5%	1/4W
R400	1-249-432-11	CARBON 18K 5%	1/4W
R401	1-249-432-11	CARBON 18K 5%	1/4W
R402	1-249-441-11	CARBON 100K 5%	1/4W
R403	1-249-425-11	CARBON 4.7K 5%	1/4W
R404	1-249-441-11	CARBON 100K 5%	1/4W
R405	1-249-432-11	CARBON 18K 5%	1/4W
R406	1-249-427-11	CARBON 6.8K 5%	1/4W
R451	1-249-427-11	CARBON 6.8K 5%	1/4W
R701	1-249-419-11	CARBON 1.5K 5%	1/4W
R702	1-249-441-11	CARBON 100K 5%	1/4W
R703	1-249-441-11	CARBON 100K 5%	1/4W
R704	1-247-807-00	CARBON 100 5%	1/4W
R705	1-249-417-11	CARBON 1K 5%	1/4W
< SWITCH >			
△S901	1-572-675-11	SWITCH, POWER VOLTAGE CHANGE (VOLTAGE SELECTOR) (E)	
< TRANSFORMER >			
△T901	1-423-979-11	TRANSFORMER, POWER (EXCEPT CND,E)	
△T901	1-426-621-11	TRANSFORMER, POWER (CND)	
△T901	1-426-622-11	TRANSFORMER, POWER (E)	
< TERMINAL >			
* TPT901	1-535-771-11	TERMINAL (CND,E,AUS,CH)	
* TPT902	1-535-771-11	TERMINAL (CND,E,AUS,CH)	
< VIBRATOR >			
X201	1-579-833-21	VIBRATOR, CRYSTAL (33.8688MHz)	

Ref. No.	Part No.	Description	Remark
*	A-4673-760-A	PANEL BOARD, COMPLETE	

< CAPACITOR >			
C501	1-161-494-00	CERAMIC 0.022uF	25V
C502	1-161-494-00	CERAMIC 0.022uF	25V
C503	1-161-494-00	CERAMIC 0.022uF	25V
C505	1-161-494-00	CERAMIC 0.022uF	25V
< CONNECTOR >			
* CN501	1-568-864-11	SOCKET, CONNECTOR 21P	
< FLUORESCENT INDICATOR TUBE >			
FL501	1-517-297-11	INDICATOR TUBE, FLUORESCENT	
< IC >			
IC501	8-752-869-51	IC CXP82612-021Q	
IC502	8-741-810-59	IC SBX1810-59	
< TRANSISTOR >			
Q501	8-729-029-67	TRANSISTOR DTC114ESA-TP	
< RESISTOR >			
R501	1-249-427-11	CARBON 6.8K 5%	1/4W
R502	1-249-427-11	CARBON 6.8K 5%	1/4W
R503	1-249-431-11	CARBON 15K 5%	1/4W
R504	1-249-427-11	CARBON 6.8K 5%	1/4W
R505	1-249-423-11	CARBON 3.3K 5%	1/4W
R506	1-249-421-11	CARBON 2.2K 5%	1/4W
R510	1-249-427-11	CARBON 6.8K 5%	1/4W
R511	1-249-415-11	CARBON 680 5%	1/4W
R512	1-249-417-11	CARBON 1K 5%	1/4W
R513	1-249-419-11	CARBON 1.5K 5%	1/4W
R514	1-249-421-11	CARBON 2.2K 5%	1/4W
R515	1-249-423-11	CARBON 3.3K 5%	1/4W
R516	1-249-427-11	CARBON 6.8K 5%	1/4W
R517	1-249-431-11	CARBON 15K 5%	1/4W
R519	1-249-441-11	CARBON 100K 5%	1/4W
R520	1-249-427-11	CARBON 6.8K 5%	1/4W
R530	1-249-429-11	CARBON 10K 5%	1/4W
R531	1-249-429-11	CARBON 10K 5%	1/4W
R550	1-247-842-11	CARBON 3K 5%	1/4W
< SWITCH >			
S501	1-554-303-21	SWITCH, TACTILE (TIME)	
S502	1-554-303-21	SWITCH, TACTILE (REPEAT)	
S503	1-554-303-21	SWITCH, TACTILE (PLAY MODE)	
S520	1-554-303-21	SWITCH, TACTILE (▷)	

<p>The components identified by mark △ or dotted line with mark. △ are critical for safety. Replace only with part number specified.</p>	<p>Les composants identifiés par une marque △ sont critiques pour la sécurité. Ne les remplacer que par une pièce portant le numéro spécifié.</p>
--	---

CDP-XE200/XE300

PANEL

POWER SW

Ref. No.	Part No.	Description	Remark
S521	1-554-303-21	SWITCH, TACTILE (■)	
S522	1-554-303-21	SWITCH, TACTILE (■)	
S523	1-554-303-21	SWITCH, TACTILE (ENTER)	
S524	1-554-303-21	SWITCH, TACTILE (CLEAR)	
S525	1-554-303-21	SWITCH, TACTILE (CHECK)	
S526	1-554-303-21	SWITCH, TACTILE (▶▶)	
S527	1-554-303-21	SWITCH, TACTILE (◀◀)	
S530	1-554-303-21	SWITCH, TACTILE (≡ OPEN/CLOSE)	
S531	1-473-452-11	ENCODER, ROTARY (◀◀ AMS ▶▶)	
		< VIBRATOR >	
X501	1-577-082-11	VIBRATOR, CERAMIC (4MHz)	

*	1-658-840-11	POWER SW BOARD	

		< SWITCH >	
△ S801	1-554-118-00	SWITCH, PUSH (1 KEY) (POWER)	

		MISCELLANEOUS	

4	1-776-100-11	WIRE (FLAT TYPE) (23 CORE)	
6	1-776-099-11	WIRE (FLAT TYPE) (21 CORE)	
△ 55	1-569-007-11	ADAPTOR, CONVERSION 2P (E)	
△ 56	1-569-008-11	ADAPTOR, CONVERSION 2P (CH)	
* 111	1-452-538-11	MAGNET (AEP,UK,G,EE)	
111	1-452-538-41	MAGNET (CND,E,AUS,CH)	
△ 155	8-848-379-31	PICK-UP BLOCK, OPTICAL KSS-213BA/F-NP	
158	1-769-069-11	WIRE (FLAT TYPE) (16 CORE)	
△ CNP901	1-558-943-81	CORD, POWER (E)	
△ CNP901	1-558-945-21	CORD, POWER (POLAR.SPT-1) (CND)	
△ CNP901	1-575-651-21	CORD, POWER (AEP,G,EE)	
△ CNP901	1-696-845-11	CORD, POWER (AUS)	
△ CNP901	1-696-907-11	CORD, POWER (UK)	
△ CNP901	1-696-966-11	CORD, POWER (CH)	
M101	X-4917-523-3	BASE (OUTSERT) ASSY (SPINDLE)	
M102	X-4917-504-1	MOTOR ASSY (SLED)	
M151	A-4604-363-A	MOTOR (L) ASSY (LOADING)	

Ref. No.	Part No.	Description	Remark
		ACCESSORIES& PACKING MATERIALS	

	1-467-880-11	REMOTE COMMANDER (RM-D420) (XE300)	
	1-558-271-11	CORD, CONNECTION	
	3-810-322-11	MANUAL, INSTRUCTION (ENGLISH,FRENCH, SPANISH,CHINESE) (CND,E,AUS,CH)	
	3-810-322-31	MANUAL, INSTRUCTION (ENGLISH,FRENCH, SPANISH) (AEP,UK)	
	3-810-322-41	MANUAL, INSTRUCTION (GERMAN,DUTCH, ITALIAN,PORTUGUESE) (AEP)	
	3-810-322-51	MANUAL, INSTRUCTION (GERMAN) (G)	
	3-810-322-61	MANUAL, INSTRUCTION (SWEDISH,FINNISH, DANISH) (AEP)	
	3-810-322-71	MANUAL, INSTRUCTION (ENGLISH,RUSSIAN, POLISH) (EE)	
*	3-948-574-01	SHEET (ROLL), PROTECTION (AEP,UK,G,EE)	
*	4-925-389-11	CUSHION (E)	
	4-962-615-01	COVER, BATTERY (FOR REMOTE COMMANDER) (XE300)	
*	4-979-603-41	INDIVIDUAL CARTON (XE200:CND,AUS)	
*	4-979-603-51	INDIVIDUAL CARTON (XE300:CND,AUS)	
*	4-979-603-61	INDIVIDUAL CARTON (E,CH)	
*	4-979-604-01	CUSHION (CND,E,AUS,CH)	
*	4-979-605-21	INDIVIDUAL CARTON (XE300:AEP,UK,G,EE)	
*	4-979-605-31	INDIVIDUAL CARTON (XE200:AEP,UK,G,EE)	
*	4-979-606-01	CUSHION (AEP,UK,G,EE)	

		HARDWARE LIST	

#1	7-685-646-79	SCREW +BVTP 3X8 TYPE2 N-S	
#2	7-682-548-04	SCREW +BVTT 3X8 (S)	
#3	7-621-775-10	SCREW +B 2.6X4	
#4	7-621-255-15	SCREW +P 2X3	

The components identified by mark △ or dotted line with mark. △ are critical for safety. Replace only with part number specified.

Les composants identifiés par une marque △ sont critiques pour la sécurité. Ne les remplacer que par une pièce portant le numéro spécifié.