

CDM82A/82B

Mechanical Operation

CMT-HPX11D (HCD-HPX11D)

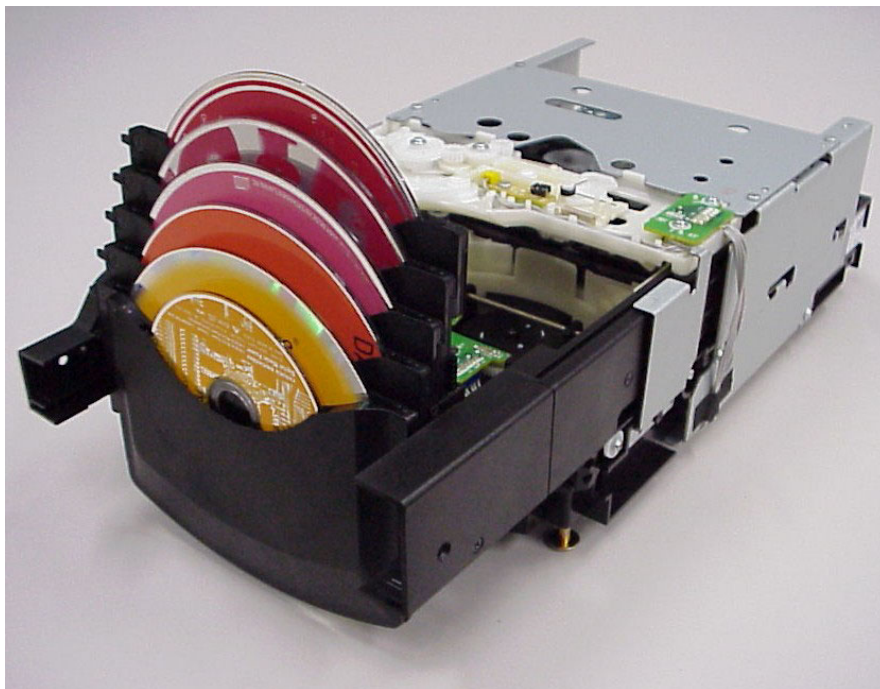

Sony EMCS Corporation - Kisarazu TEC
HA Business Div. Global Operation Dept.
Global Service Strategy Sect.

Table of Contents

1. Ejecting the Disc	Page 3
(1) Ejecting the disc in the stocker block	
(2) Ejecting the disc chucked in the CDM80	Page 4
2. Operation Mechanism	Page 6
(1) Motor	
(2) Detecting the operation	Page 7
(3) Detecting the disc	Page 8
3. Phase Adjustment of the Mechanism Block	Page 9
(1) Rotary encoder	
(2) SUB GEAR (IDLER)	
4. Maintenance	Page10
(1) Adding grease	
(2) Cleaning	
5. Initial Operation of the Mechanism Block	Page12
6. Troubleshooting	
(1) Checking the Disc	
(2) Checking the distortion of the unit	

(Important) Page number and CDM name

The referenced page number and figure number in parentheses are those of the HCD-HPX11D Service Manual.

In the following description, the whole changer block is referred to as "CDM82" and the disc chucking mechanism block is referred to as "CDM80".

1. Ejecting the Disc

(1) Ejecting the disc in the stocker block

If you rotate the PULLEY (LOD MOTOR) on the side surface of the mechanical block after removing the CDM82 from the set, the stocker block moves slightly forward.

(Refer to the first figure in "3-15 Arm Section" on page 20.)

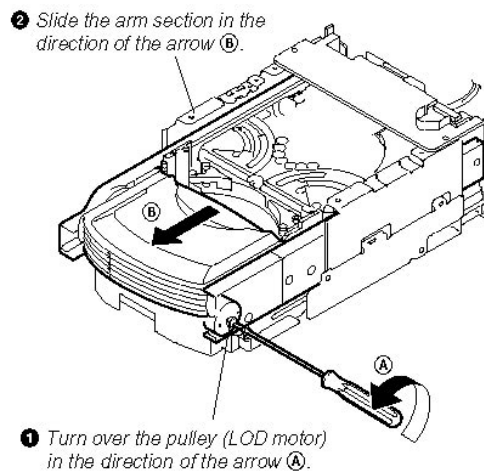

Gently pull out the stocker block that has been moved slightly forward, to reveal the LOADING MOTOR (page 112, M871). Pull out the stocker block as far as possible. Rotate, with your fingers the PULLEY (page 112, 956) around which the loading motor belt is wound, to rotate the stocker by 90 degrees.

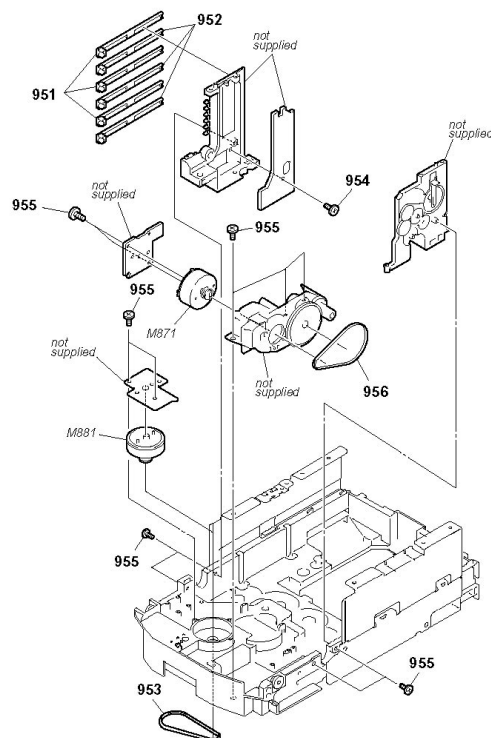

Press the levers beside the disc insertion slots of the respective trays to remove the discs. Pressing the levers will make the discs pop out. Be careful not to damage the discs.

After removing the discs, reverse the above procedure. No particular adjustment of the mechanism block is required.

(2) Ejecting the disc chucked in the CDM80

First, remove the CDM80 from the CDM82.

Slide the stocker block forward. (Refer to 3-15 on page 20.)

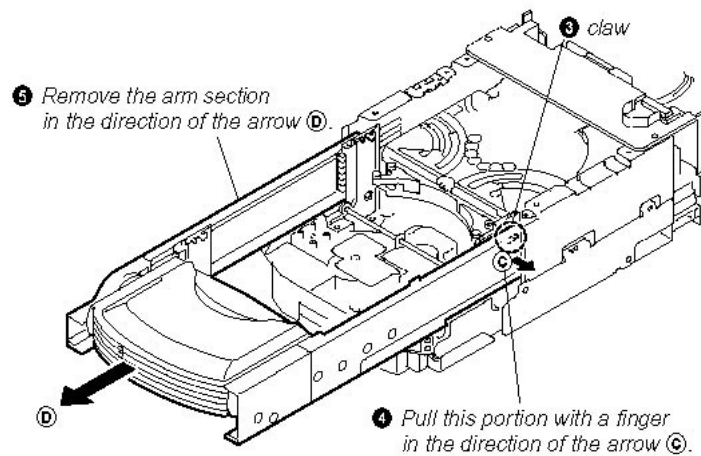

Rotate the PULLEY (ELV MOTOR) to move the CDM80 to the uppermost position, where the CDM80 can be removed. (Refer to 3-16 on page 21.)

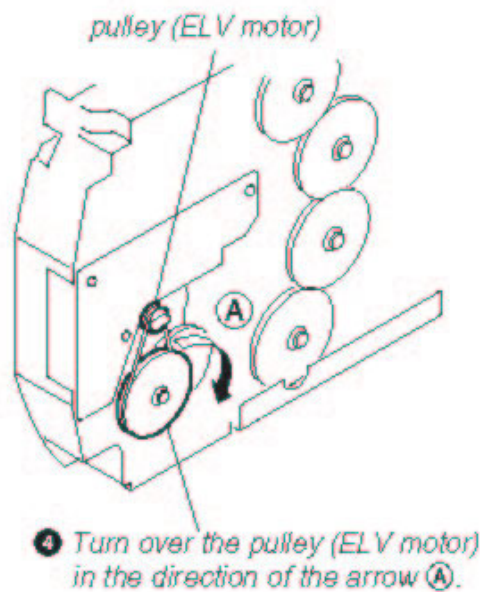

Remove the base (a not-supplied part shown at the bottom of page 114) installed in the CDM80, and rotate the PULLEY (GEAR) (1054 on page 114) clockwise to eject the disc.

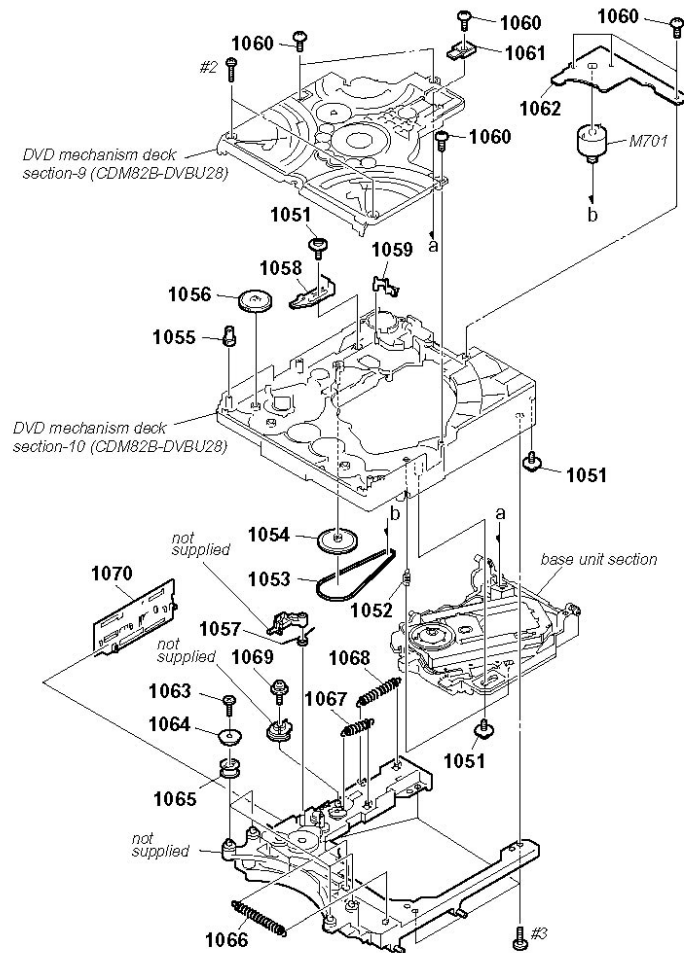

After removing the discs, reverse the above procedure. No particular adjustment of the mechanism block is required.

2. Operation Mechanism

(1) Motor

Three motors are used to operate the mechanism block.

① Loading motor (M871 on page 112)

Moves the stoker to the front or back.

When ejecting the disc, the stoker block first moves to the front and slightly to the back, then rotates by 90 degrees.

When loading the disc, on the contrary, the stoker block rotates by 90 degrees, slightly moves to the front, then move to the back.

② Elevator motor (M881 on page 112)

Moves the CDM80 up and down.

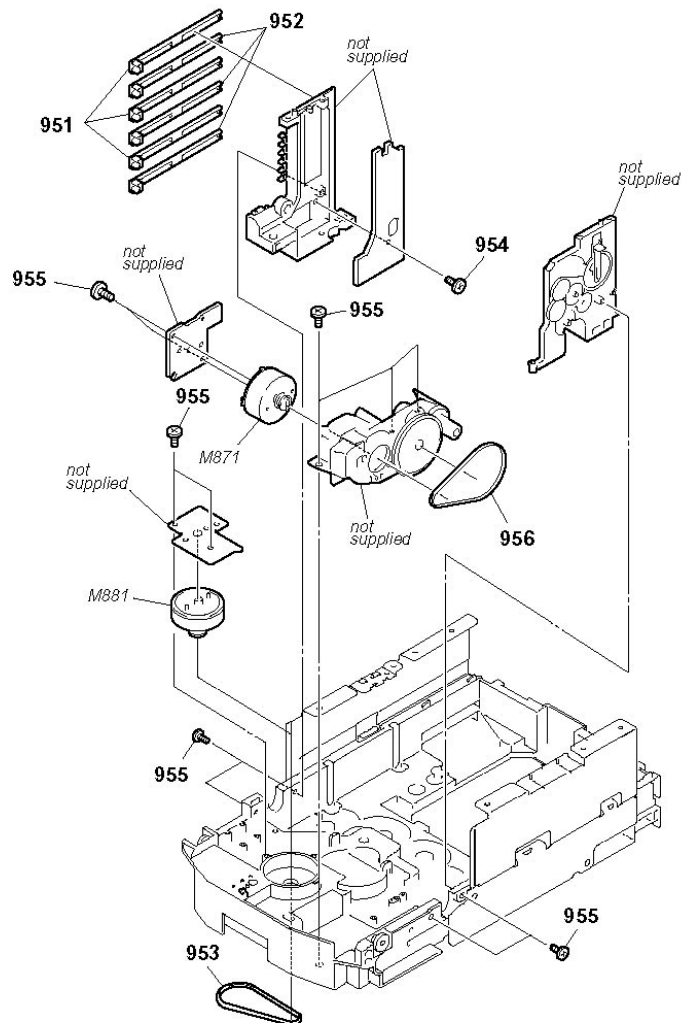

③ Loading DC motor (M701 on page 114)

Loads/ejects the disc on/from the CDM80 and catches/releases the base unit.

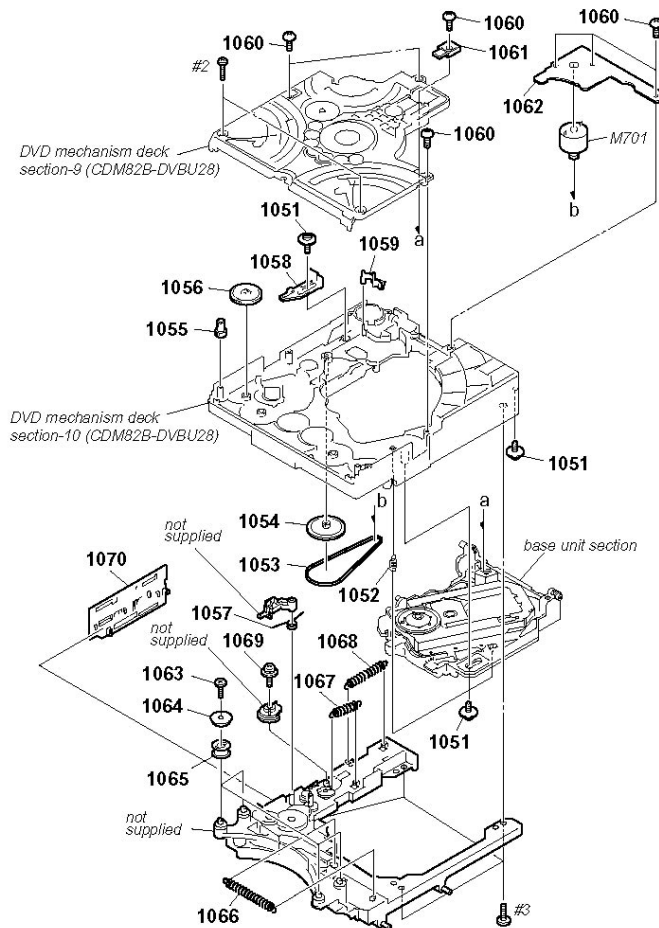

(2) Detecting the operation

S881 (ROTARY ENCODER ELV)

The elevator position of the CDM80 and the mechanism mode can be detected by the switches within the rotary encoder.

The completion of ejecting and loading operations can be detected by the following five mechanism switches.

① S701 (OUT)

This switch detects the disc inserted in the CDM80 and completion of the ejecting operation of the CDM80.

If it detects that the disc is inserted when the system starts up, it attempts to eject the disc until the disc is ejected.

② S702 (CHUCK)

When the CDM80 base unit elevates, the completion of chucking operation of the disc is detected.

③ S821 (LOD POSITION/CLOSE)

The stocker is housed in the set and the S821 detects that the stocker is ready in the loading position. If the stocker is not ready in the loading position when the system starts up, it starts the loading operation of the stocker.

④ S811 (OPEN)

This switch detects that the stocker block is ready in the ejecting position.

If the stocker is in the ejecting position when the system starts up, it starts the loading operation of the stocker.

⑤ S831 (PUSH, CLOSE)

This switch detects that the stocker block is pushed in the ejecting state and starts the ejecting operation.

(3) Detecting the disc

The presence/absence of the disc in the tray is detected by the six mechanical switches.

The disc in the 8 cm dedicated tray is detected by the DISC+1 switch. DISC1 is the lowermost tray.

① S861 (DISC1)

② S862 (DISC2)

③ S863 (DISC3)

④ S864 (DISC4)

⑤ S865 (DISC5)

⑥ S866 (DISC+1) Tray dedicated for 8 cm disc

In addition, there are two switches that detect the size of the disc in the CDM80 when the power is turned off while a disc is still inserted. If the switches detect the size of the disc, the disc is returned to the correct stocker position. (For example, a 12 cm disc is returned to the empty tray having the smallest number.)

① S841 (8 cm)

② S851 (12 cm)

3. Phase Adjustment of the Mechanism Block

(1) Rotary encoder

(Refer to 3-30 on page 31.)

If the gear near the rotary encoder is removed, this phase adjustment will be required.

If this phase adjustment is not correctly performed, the elevator position of the CDM80 will be erroneously detected, resulting in symptoms such as the elevator continues to move down after reaching the lowermost position upon turning on the power, or loading of the disc in the CDM80 fails.

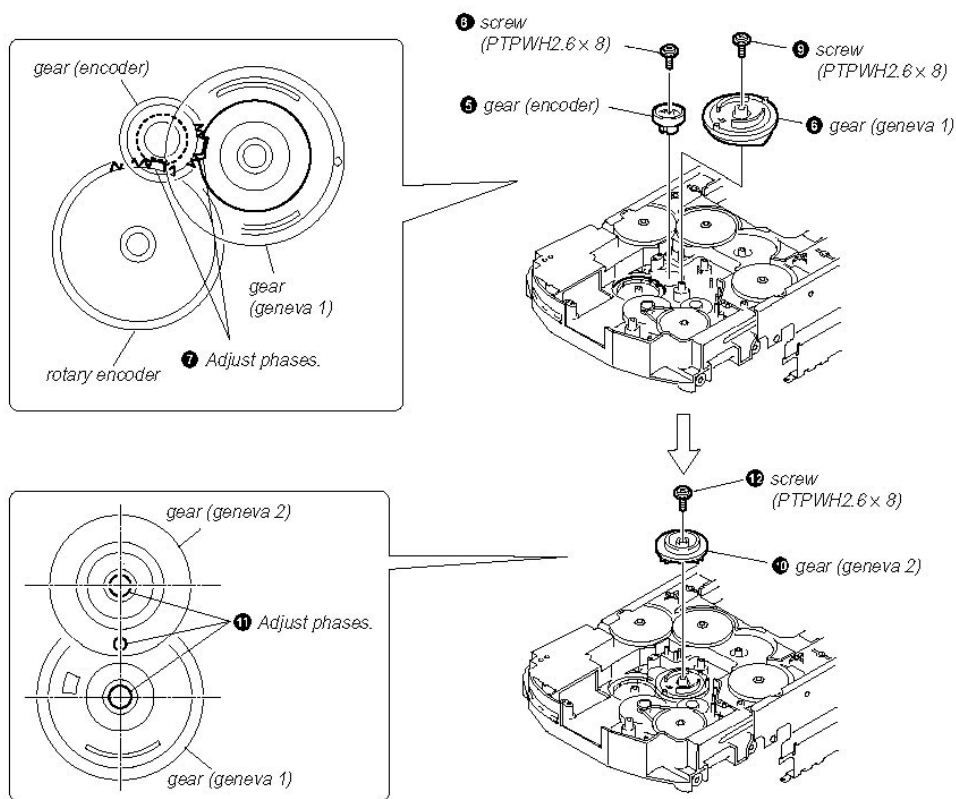

(2) SUB GEAR (IDLER)

(Refer to 4-12 on page 53.)

If the gear on the side surface is removed, this phase adjustment will be required.

If this phase adjustment is not correctly performed, the tray will not be horizontal when the disc is pulled in, resulting in abnormal operation of the mechanism block.

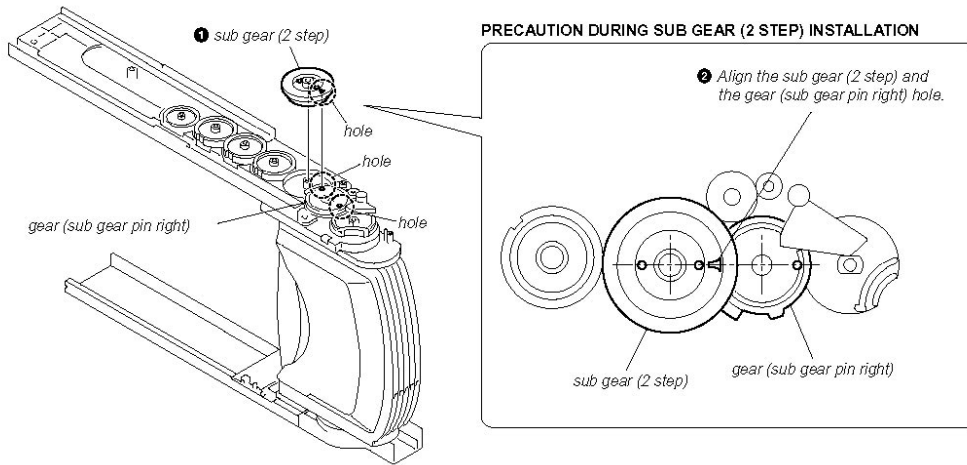

4. Maintenance

(1) Adding grease

Grease does not need to be added except when two parts whose contact surfaces are greased, are replaced at the same time.

(2) Cleaning

Because the driving force of the motor is sufficiently large, adhesion of small dust or dirt should not increase the mechanical load.

If the disc cannot be pulled in due to the adhesion of dust to the "Roller, Rubber" (1102 on page 115), clean it with alcohol.

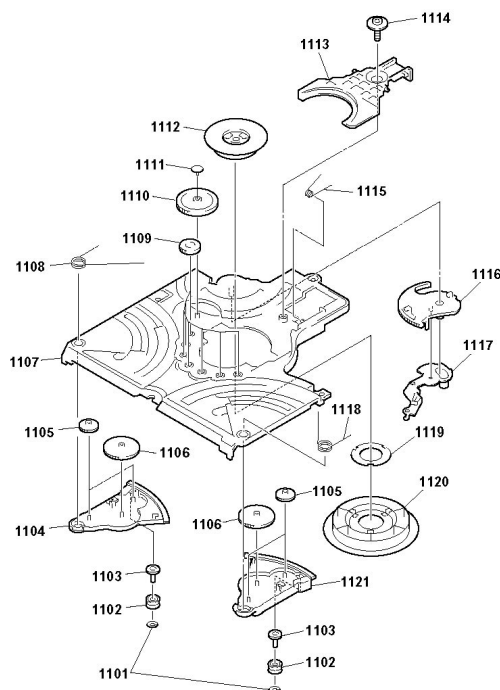

If dust is adhered to the motor driving belts (953 and 956 on page 112), remove it by wiping the belts with alcohol. Be careful that grease must not attach to other parts when assembling the set.

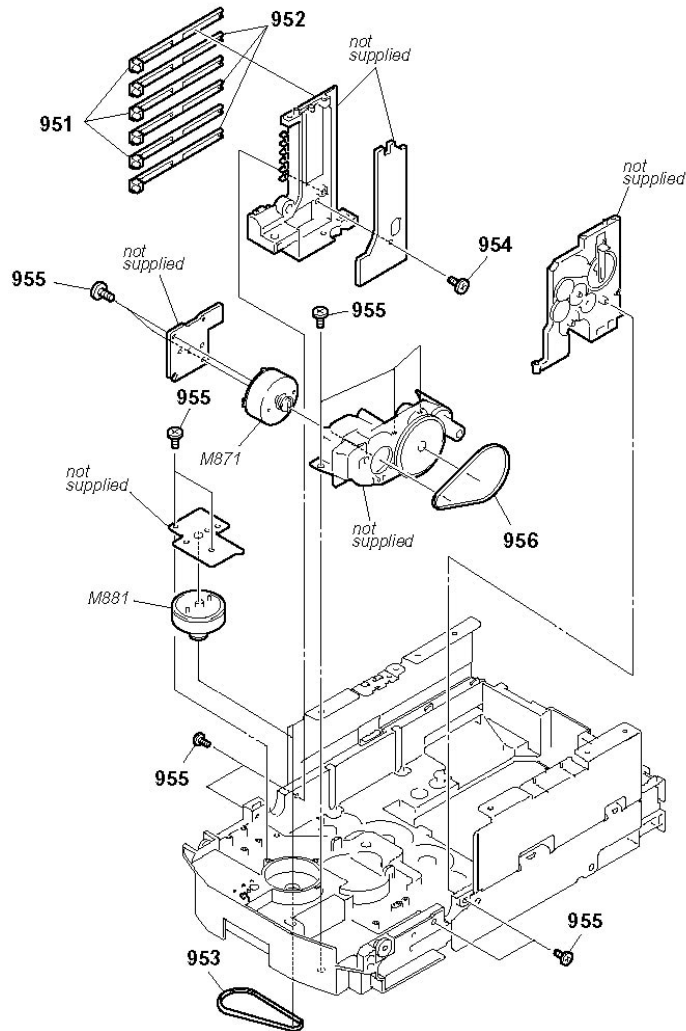

5. Initial Operation of the Mechanism Block

When the AC plug is connected to the outlet and the power of the unit is turned on, the following initial operations of the mechanism block are performed:

- ① The mechanical mode is detected by the rotary encoder.
- ② If the stocker has not completely been pulled in, it is pulled in until it is locked.
- ③ Presence/absence of the disc in the stocker is detected by the mechanical switches.
- ④ If the CDM80 is not in the ejecting mode, ejecting operation starts. The disc size (8/12 cm) in the CDM80 is detected during the ejecting operation to determine the tray to be returned. (The 8 cm disc is returned to the 8 cm stocker.) The CDM80 moves to the position that is as high as the empty tray. Then the loading motor (M701) rotates to return the disc in the CDM80 to the stocker.
- ⑤ The CDM80, in the ejecting state, moves to the lowermost position of DISC1.
- ⑥ The operation stops.

6. Troubleshooting

(1) Checking the disc

If the disc remains in the CDM80 and cannot be ejected, check whether the disc label of the disc has been peeled off. In addition, check whether excess oil is attached to the disc.

(2) Checking the distortion of the unit

Check whether the set has been damaged by being dropped or other reasons. If the mechanism block has any distortion, it may not be able to operate normally.