

# DPS-R7

## SERVICE MANUAL

US Model  
Canadian Model  
AEP Model  
UK Model  
E Model

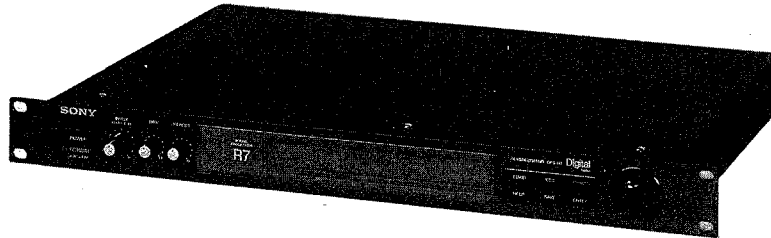

### SPECIFICATIONS

A/D Converter 18 bit oversampling  
Stereo A/D converter  
D/A Converter Pulse D/A converter  
Sampling Freq. 40 kHz

Memory  
Preset memory  
User memory  
Power requirement

100 effects  
maximum of 256 effects  
USA and Canadian model  
120 V AC, 60 Hz

UK model  
240 V AC, 50/60 Hz  
(adjustable with a voltage selector)

Continental European model  
230 V AC, 50/60 Hz  
(adjustable with a voltage selector)

Power consumption 28 W  
Dimensions

Approx. 482 × 44 × 320 mm  
(19 × 1<sup>3</sup>/<sub>4</sub> × 12<sup>5</sup>/<sub>8</sub> inches)  
(excluding projections)  
(w/h/d)

Weight

4.8 kg (10 lb 10 oz)

Design and specifications are subject to change without notice.

#### Note:

This appliance conforms with EEC Directive 87/308/EEC regarding interference suppression.

#### Input

Connector type	Reference input level	MAX. input level	Input Impedance	Circuitry type
XLR-3-31 equivalent	+4 dBs	+24 dBs	10 k $\Omega$	Balanced
Phone jack	-10 dBs	+10 dBs	50 k $\Omega$	Unbalanced

XLR-3-31 equivalent connector (1:GND 2:HOT 3:COLD)

#### Output

Connector type	Reference output level	MAX. output level	Output Impedance	Circuitry type
XLR-3-32 equivalent	+4 dBs	+24 dBs	Min. 600 $\Omega$	Balanced
Phone jack	-10 dBs	+10 dBs	Min. 10 k $\Omega$	Unbalanced

XLR-3-32 equivalent connector (1:GND 2:HOT 3:COLD)

#### General

Frequency response 10-18 kHz  $\pm$ 0.5 dB  
Signal-to-noise ratio more than 90 dB  
Dynamic range more than 90 dB  
Total harmonic distortion less than 0.004% (1 kHz)





DIGITAL REVERBERATOR  
**SONY**<sup>®</sup>

## TABLE OF CONTENTS

<u>Section</u>	<u>Title</u>	<u>Page</u>
	Specification.....	1
<b>1.</b>	<b>GENERAL .....</b>	<b>3</b>
<b>2.</b>	<b>LIST OF IC TERMINALS .....</b>	<b>5</b>
<b>3.</b>	<b>DISASSEMBLY.....</b>	<b>11</b>
<b>4.</b>	<b>ADJUSTMENT.....</b>	<b>11</b>
<b>5.</b>	<b>DIAGRAMS</b>	
5-1.	Block Diagram .....	12
5-2.	Printed Wiring Boards.....	16
5-3.	Schematic Diagram (1).....	19
5-4.	Schematic Diagram (2).....	23
5-5.	IC Block Diagrams.....	27
<b>6.</b>	<b>EXPLODED VIEW .....</b>	<b>30</b>
<b>7.</b>	<b>ELECTRICAL PARTS LIST .....</b>	<b>32</b>

**SAFETY-RELATED COMPONENT WARNING!!**

COMPONENTS IDENTIFIED BY MARK  OR DOTTED LINE WITH MARK  ON THE SCHEMATIC DIAGRAMS AND IN THE PARTS LIST ARE CRITICAL TO SAFE OPERATION. REPLACE THESE COMPONENTS WITH SONY PARTS WHOSE PART NUMBERS APPEAR AS SHOWN IN THIS MANUAL OR IN SUPPLEMENTS PUBLISHED BY SONY.

**ATTENTION AU COMPOSANT AYANT RAPPORT À LA SÉCURITÉ!**

LES COMPOSANTS IDENTIFIÉS PAR UNE MARQUE  SUR LES DIAGRAMMES SCHÉMATIQUES ET LA LISTE DES PIÈCES SONT CRITIQUES POUR LA SÉCURITÉ DE FONCTIONNEMENT. NE REMPLACER CES COMPOSANTS QUE PAR DES PIÈCES SONY DONT LES NUMÉROS SONT DONNÉS DANS CE MANUEL OU DANS LES SUPPLÉMENTS PUBLIÉS PAR SONY.

## Overview of the DPS-R7

The DPS-R7 is a digital reverbator equipped entirely with Sony's digital and audio technology at its highest level of sophistication which was released before with the Digital Reverbator, DRE-2000 and ML-R201 and achieved much appraisal.

**Quality-conscious design - A/D and D/A high performance converter**

The DPS-R7 converts the incoming analog signal to a digital signal, passes it through various effects, then re-converts it to an analog signal before output. The determinant to the sound quality is the conversion mechanism that adopts the 18-bit oversampling stereo A/D converter and the pulse D/A converter of 40.96 MHz. These account for highly accurate, less deteriorated effects.

**User-friendly and comfortable operation**

The large size backlit LCD of 40 characters by 2 lines makes it possible to proceed with smooth operation while viewing the operating condition in real time. Moreover, the LCD display incorporates an on-line manual (in English) which displays information required for operation.

**Abundant preset memory settings**

The unit has a hundred variations of the effects created by musicians, sound mixers and acoustic engineers around the world in its preset memory. This will help you select and replay immediately the desired effects for a particular purpose.

**Sound creation of any kind**

The EDIT function allows you to modify the presets or to create some individual effects. Besides the preset memory for a hundred effects, the unit has a so-called user memory where you can save up to 255 effects you are going to create. Using this memory allows more varicolored play of effects.

**Wide range of effects**

The DPS-R7 consists mainly of a reverbation block together with an input block, a pre-effect block, a post-effect block and an output block for signal processing.

For Processing signals with stereo-input/stereo-output in the reverbation block, one of 5 types of ST-ST algorithms is available, while the monaural-input/stereo-output processing allows you to take any two types of MONO-ST algorithm. One of the six types of algorithms can be used in the pre-effect block and one of seven in the post-effect block.

By combining these blocks and algorithms used in the blocks, a wide range of effects will be able to be created according to the input source.

**Remote control**

The remote commander (not supplied) makes it possible to remotely control the unit.

**2 types of I/O connectors are provided**  
The DPS-R7 has XLR connectors (balanced-type) and phone jacks so that it can be connected to instruments, recording equipment or PA (public address) equipment.

**Linkage with MIDI equipment**

The MIDI device incorporated in the DPS-R7 can receive program change signals from another MIDI equipment connected so that the DPS-R7 can be controlled by the MIDI equipment connected. Thus, it can function as an effector when connected to digital instruments. In addition, controls from PC's or MIDI sequencers are very helpful for composition.

## Hooking Up a System

Turn all the power off before making connections, and connect the AC power cord last.

### Fundamental Connections as an Effector

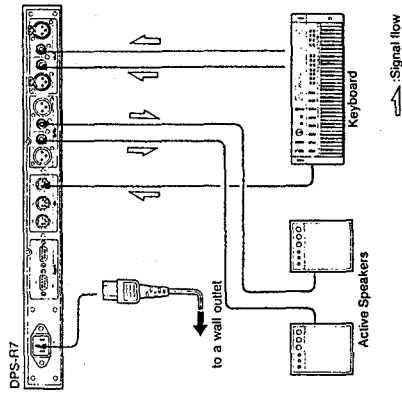

1. Connect a keyboard to the INPUT jacks, or the MIDI IN connector.
2. Connect active speakers to the OUTPUT jacks.
3. Insert the AC power cord firmly into the AC IN jack.
4. Connect the AC power cord to a wall outlet.

For models equipped with a voltage selector

Check to confirm that the voltage selector is set to the local power line voltage. If not, set the selector to the correct position before connecting the AC power cord to a wall outlet.

Notes:

- Be sure to insert the plugs firmly into the jacks. Loose connection may cause hum and noise.
- Leave a little slack in the connecting cord to allow for inadvertent shock or vibration.
- Connect the AC power cord last.
- Connections with some equipment of which the output capacity is very high may result in sound distortion. When this happens, turn the INPUT control to lower the input level, or turn the output level of the equipment connected to the DPS-R7.

## SECTION 1 GENERAL

This section is extracted from instruction manual.

### Fundamental Connections for Recording

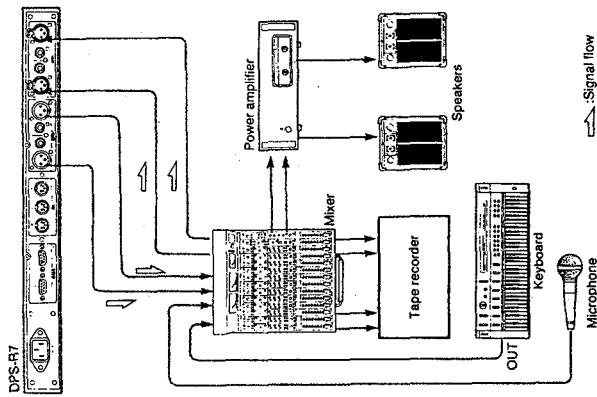

Notes:

- If only one channel is used, connect it to the INPUT CH1 and set the input mode in the System block to "mono". See page 40.
- This allows you to obtain the same result as you do when the mode is set to "stereo" and the same signal is input both to the INPUT CH1 and INPUT CH2.
- Be sure to input the signal with the reference level of +4 dB to the XLR-3-31 connector.
- Since the reference level of phone jack is set at -10 dB, any input signal exceeding the maximum input level of +10 dB causes clipping to the amplifier before the input volume and sound may be distorted.
- An optional remote commander RM-DPS7 can be connected to the REMOTE IN connector to remotely control this unit.

Identifying the Parts

Front panel

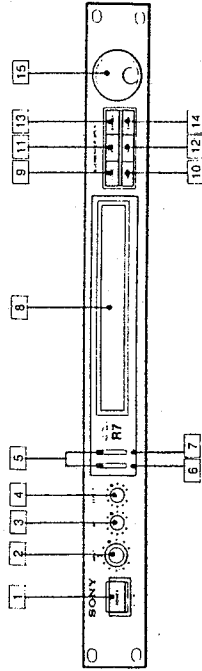

- 1 **POWER switch**  
Turns the unit on and off. When the power is on, the back light of the display window illuminates and the last indication appears. For a few seconds after switching on, the sound being input will be directly output since the bypass function works.
- 2 **INPUT control**  
Adjusts the input levels of two channels independently. The outside knob controls channel 1, and the inside knob controls channel 2. Since they are linked with each other, hold whichever you do not use to adjust for one channel only.
- 3 **DRY (original sound) control**  
Adjusts the output level of the source signal which is clear of any effect. Using this control in conjunction with the EFFECT control can adjust the balance between the source signal and the effect signal when mixing them. To output only the effect signal, set the control to "0".
- 4 **EFFECT control**  
Adjust the output level of the effect signal. Using this control in conjunction with the DRY control can adjust the balance between the source signal and the effect signal when mixing them.
- 5 **Input level meter**  
Indicates input level for both channels independently. Adjusts the INPUT control so that 0 dB is fit when the signal of the reference level is input. 0 dB means the head room of 20 dB. When the signal exceeds this head room, "OVER" illuminates. This meter does not work when the BYPASS button is pressed.
- 6 **MIDI indicator**  
Illuminates when the unit receives the MIDI program change signal or control change signal.

To be continued ▶

Identifying the Parts

Rear panel

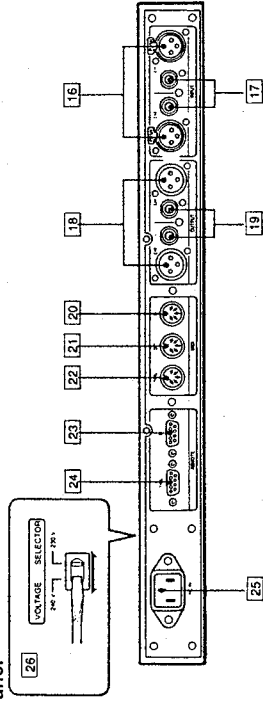

- 7 **REMOTE indicator**  
Illuminates when the unit receives the signal from an optional remote commander.
- 8 **Display window**  
A display of 40 characters by 2 lines on which names of called memory, parameter values and/or messages are indicated. Displayed indication is easy to read in a dark hall or a studio due to the back lighting.
- 9 **LOAD button**  
Press the button to call up the memory.
- 10 **HELP button**  
Press the button to display information or messages necessary to proceed with operation.
- 11 **EDIT button**  
Press the button to change parameter values in the memory.
- 12 **SAVE button**  
Press the button to save the effects individually created in the user memory.
- 13 **BYPASS button**  
Press the button to output the input signal directly.
- 14 **ENTER button**  
Press the button every time you have finished selecting or setting parameters.
- 15 **Operating dial**  
Selects preset numbers and/or sets parameters.
- 16 **INPUT CH1/CH2 terminal (XLR-3-31 connector)**  
Balanced-type terminals for input of ch1 and ch2.
- 17 **INPUT CH1/CH2 terminal (phone jack)**  
Phone jacks for input of ch1 and ch2.
- 18 **OUTPUT CH1/CH2 terminal (XLR-3-32 connector)**  
Balanced-type terminals for output of ch1 and ch2.
- 19 **OUTPUT CH1/CH2 terminal (phone jack)**  
Phone jacks for output of ch1 and ch2. When both XLR connectors and phone jacks are used, the equipment connected to the phone jacks will be given a priority.
- 20 **MIDI IN terminal (DIN 5-pin)**  
Input terminal for the MIDI signal. A commercially available MIDI cable can be connected between this terminal and a MIDI OUT (or THRU) terminal of another MIDI equipment.
- 21 **MIDI OUT terminal (DIN 5-pin)**  
Outputs the MIDI signal generated in this unit.
- 22 **MIDI THRU terminal (DIN 5-pin)**  
This terminal directly outputs the MIDI signal received from the MIDI IN terminal. A commercially available MIDI cable can be connected between this terminal and a MIDI IN terminal of another MIDI equipment.
- 23 **REMOTE IN terminal (D-Sub 9-pin)**  
The terminal to which an optional remote commander is connected. The remote commander enables you to remotely control the unit.
- 24 **REMOTE THRU terminal (D-Sub 9-pin)**  
This terminal directly outputs the signal received from an optional commander through the REMOTE IN terminal. This terminal should be connected to a REMOTE IN terminal of any effector of the DPS series.
- 25 **AC IN jack**  
Use the supplied power cord to plug in a power outlet.
- 26 **Voltage selector**  
(only for UK and European model)  
Set the voltage selector to the correct position before connecting the AC power cord to a wall outlet.

SECTION 2  
LIST OF IC TERMINALS

IC510 CXD2903Q

Terminal No.	Terminal Name	I/O	Description
1	VDD		+5V
2	NC	open	
3	VSS		GND
4	XRD	IN	$\overline{RD}$ input
5	XAS	IN	$\overline{AS}$ input
6	RXRY	OUT	RXRDY plug of remote controller
7	XWAT	OUT	$\overline{WAIT}$ output
8	CK $\phi$	IN	$\phi$ clock input
9	PRES	OUT	Output of positive logic reset
10	XTIM	OUT	Chip select to clock IC
11	XES6	OUT	Optional chip select
12	XES7	OUT	Optional chip select
13	RIIN	IN	Data input from remote controller
14	RTIN	IN	Data input from remote controller thru
15	RIOT	OUT	Data output to remote controller
16	NC	open	
17	REA	IN	Input of rotary encoder
18	REB	IN	Input of rotary encoder
19	BCKO	OUT	Clock output of baud rate generator
20	BCKI	IN	Baud rate clock input of remote controller I/F
21	VSS		GND
22	NC	open	
23	VDD		+5V
24	NC	open	
25	NC	open	
26	SDAT	OUT	Data output to DPS
27	SCK	OUT	Data transmission clock to DPS
28	LT $\phi$	OUT	Output port DPS for data latch
29	LT1	OUT	Output port DPS for data latch
30	LT2	OUT	Output port DPS for data latch
31	NC	open	
32	VDD		+5V
33	NC	open	
34	PRAM	OUT	Chip select positive logic for SRAM
35	XRAM	OUT	Chip select negative logic for SRAM
36	A19	IN	Address input
37	A18	IN	
38	A17	IN	
39	A16	IN	
40	NC	open	
41	NC	open	
42	VDD		+5V
43	NC	open	
44	VSS		GND
45	A15	IN	Address input
46	A12	IN	Address input

## IC510 CXD2903Q

Terminal No.	Terminal Name	I/O	Description
47	A14	IN	Address input
48	NC	open	
49	A13	IN	Address input
50	A6	IN	Address input
51	A8	IN	Address input
52	A5	IN	Address input
53	A9	IN	Address input
54	A4	IN	Address input
55	A11	IN	Address input
56	A3	IN	Address input
57	A2	IN	Address input
58	A10	IN	Address input
59	A1	IN	Address input
60	XROM	OUT	ROM chip select
61	A $\bar{7}$	IN	Address input
62	VSS		GND
63	NC	open	
64	VDD		+5V
65	NC	open	
66	D7	I/O	Data bus
67	D $\bar{7}$	I/O	Data bus
68	D6	I/O	Data bus
69	D1	I/O	Data bus
70	D5	I/O	Data bus
71	D2	I/O	Data bus
72	D4	I/O	Data bus
73	D3	I/O	Data bus
74	NC	open	
75	LCDE	OUT	Output E-clock of LCD controller
76	XRES	IN	Reset input
77	XWR	IN	$\overline{\text{WR}}$ input
78	NC	open	
79	NC	open	
80	NC	open	

## IC305 CXD1144BP

Terminal No.	Terminal Name	I/O	Description
1	TEST1	I	Testing terminal. Fix this terminal to "L" level in normal usage
2	TEST2	I	Testing terminal. Fix this terminal to "L" level in normal usage
3	TEST3	I	Testing terminal. Fix this terminal to "L" level in normal usage
4	MUTE	I	Effective at time of "H" which makes output value "O"
5	SOFT	I	ON/OFF of soft muting. Mute at time of "H"
6	INAF	O	Output "H" when releasing input/output synchronization
7	INIT	I	Re-synchronization at time of starting up of real signal
8	V <sub>DD</sub>	-	+Power (+5V)
9	XIN	I	Master CLK input (f=384fs)
10	BCK	I	BCK input
11	DATA	I	Serial data input (complementary of 2)
12	LRCK	I	LRCK input
13	INT <sub>6</sub> /18	I	Assignment of input data word length, "H" : 18 bit, "L" : 16 bit
14	DPOL	I	This terminal inverses the polarity of input data. Effective at time of "H".
15	OUT <sub>6</sub> /18	I	Assignment of output data word length, "H" : 18 bit, "L" : 16 bit
16	TEST4	I	Testing terminal. Fix this terminal to "H" level in normal usage
17	SONY/I <sup>2</sup> S	I	Assignment of output format, "H" : I <sup>2</sup> S "L" : SONY
18	MODE2	I	Assignment of ADPT, "H" : 8Fs "L" : EMP Note 1
19	LE/WS	O	LE output (SONY mode) /WS output (I <sup>2</sup> S mode)
20	DATAR	O	RCH serial data output (complementary of 2)
21	GND	-	
22	GND	-	
23	DATAL	O	LCH serial data output (complementary of 2)
24	BCKO	O	BCK output
25	LRCKO	O	LRCK output
26	APT/WS	O	APT output, (SONY mode) /WS output (I <sup>2</sup> S mode)
27	MODE1	I	Assignment of ADPT, "H" : 8Fs "L" : EMP Note 1
28	ADPT	I	ON/OFF of ADPT. Turn ON at time of "H"

LCD1 Terminal Connecting Diagram

Terminal No.	Terminal Name	Contents	Connection
1	V <sub>SS</sub>	Earth electrical potential	GND 0V
2	V <sub>DD</sub>	Power for logic circuit	Apply +5V
3	V <sub>0</sub>	Contrast adjusting power	Adjust the contrast by applying 0-5V
4	RS	Register select	Various control signal inputs
5	R/W	Read light	
6	E	Enable	
7	DB <sub>0</sub>	Data input/output LSB	Data bus line <ul style="list-style-type: none"> <li>• DB<sub>7</sub> is combination use for busy flag output</li> <li>• DB<sub>0</sub>-3 are not used when connecting with 4 bit parallel output micro-computer.</li> </ul>
8	DB <sub>1</sub>	Data input/output 2 bit	
9	DB <sub>2</sub>	Data input/output 3 bit	
10	DB <sub>3</sub>	Data input/output 4 bit	
11	DB <sub>4</sub>	Data input/output 5 bit	
12	DB <sub>5</sub>	Data input/output 6 bit	
13	DB <sub>6</sub>	Data input/output 7 bit	
14	DB <sub>7</sub>	Data input/output MSB	
15	V <sub>LED</sub>	LED back light power (+)	Apply 5V voltage for LED back light to the interval between both terminals
16	V <sub>LSS</sub>	LED back light power (-)	



## ©IC501 Digital Audio Signal Processing LSI CXD1160AP

This LSI has a built-in Instruction RAM, Coefficient RAM, Data RAM, Multiplier, Level shifter, etc. This is also a digital audio signal processing LSI which is equipped with Serial I/O, Delay I/O (maximum performance : stereo 1024 sample delay), and Micro-computer interface as peripheral devices.

Terminal No.	Terminal Name	I/O	Description
1	SDT	I	This is a serial data input terminal which receives commands, coefficients, and I/O controls from a micro-computer
2	SCK	I	This is a serial clock input terminal for SDT which reads starting-up data
3	XSLD	I	This is a latch signal input terminal for system micro-computers to latch serial data in the IC. LOW active (LCK for DPAC1)
4	SI02	I	This is an input terminal which sets the number of clocks of the serial bit clock BCK during channel (ch1 or ch2) data transmission at 1 sampling interval. It will be in 32 bit clock mode at time of GND fixation and in 24 bit clock mode at time of +5V fixation. (This machine is a 32 bit one.)
5	DYSL	I	This is a delay I/O mode switching input terminal. It will be in serial mode at time of GND fixation and function in the same way as the serial I/O. It will be in delay mode at the time of +5V fixation and consists of a delay line for two channels by connecting an external DRAM (64 kbit).
6	TST	I	This is a testing pin. It is normally fixed to GND
7	VSS		This is a GND terminal
8	MCK1	I	This terminal is the master clock input 1. The master clock ACK in the IC is 1/2 frequency of this frequency. Fix MCK2 to +5V when inputting the master clock from MCK1.
9	MCK2	I	This terminal is the master clock input 2. The master clock ACK in the IC has the same frequency as this frequency. Fix MCK1 to +5V when inputting the master clock from MCK2.
10	SI	I	This is a serial data inputting terminal for 1 sampling of 2 channels.
11	SO	O	This is a serial data outputting terminal for 1 sampling of 2 channels.
12	BCK	I	This is a serial bit clock inputting terminal for SI and SO. This BCK terminal reads serial input data when starting up and sends output data at the last transition.(64FS)
13	LRCK	I	This is an FS clock inputting terminal for I/O.(1FS)
14	XOVF	O	Arithmetic overflow detecting output. "L" when there is overflow
15	A6	O	External DRAM address output A6
16	A3	O	External DRAM address output A3
17	A4	O	External DRAM address output A4
18	A5	O	External DRAM address output A5
19	A7	O	External DRAM address output A7
20	XCLR	I	This is a testing pin. It is normally fixed to +5V
21	VDD	-	+5V power terminal
22	A1	O	External DRAM address output A1
23	A2	O	External DRAM address output A2
24	A0	O	External DRAM address output A0
25	XRAS	O	This is a low address strobe outputting terminal for an external DRAM
26	XWSO	O	This is a serial data inputting terminal when DYSL is "L" and functions according to each serial I/O mode. It will also be the write enable outputting terminal when DYSL is "H".
27	DIO	I/O	This is a serial data outputting terminal when DYSL is "L" and reads according to each serial I/O mode. It will also be an external DRAM data input/output terminal when DYSL is "H" and will be a common line for DRAM data input $D_{in}$ and data output $D_{out}$
28	XCAS	O	This is an external DRAM column address strobe outputting terminal

Terminal No.	Terminal Name	I/O	Description
1	A4	0	External D-RAM address output terminal, A0 : LSB A8 is opened when 256kD-RAM is in use
2	A5		
3	A6		
4	A7		
5	A8		
6	VSS1		GND side power terminal, external short circuit with pin 30
7	XIN	I	Input terminal for crystal oscillator or input terminal for external clock
8	XOUT	O	Output terminal for crystal oscillator
9	SCK	O	Clock output terminal for external IC
10	24/32	I	Bit clock number selection terminal "H" : 24 bit "L" : 32 bit
11	EXT/INT	I	Serial data transmission mode selection terminal "H" : LRCK, BCK terminals are for inputting. External synchronization "L" : LRCK, BCK terminals are for outputting. Internal synchronization
12	RAM-SEL	I	External D-RAM capacity selection terminal "H" : 1M "L" : 256k
13	DATA-SEL	I	Used number of external D-RAM and data bit number selection terminal "H" : 3, 24 bit "L" : 2, 16 bit
14	TEST	I	Testing terminal. This terminal is fixed to "L" when not in use. It is available as a reset terminal of a data address counter. (Refer to "How to use testing terminal" for details.)
15	DAOUT	O	Serial output terminal of digital audio/stereo signal data
16	BCK	I/O	Bit clock input/output terminal for DAOUT sending DAOUT data is converted by the last transition of this signal
17	LRCK	I/O	Sampling frequency clock input/output terminal "H" : L-CH transmission, "L" : R-CH transmission
18	ADIN	I	Serial output terminal of digital audio/stereo signal data
19	PRG-L	I	This is the signal input terminal which latches and transmits the PRG-DT data serial input to the parallel latch circuit "H" : Latch, "L" : Transmission
20	PRG-DT	I	Serial data input terminal of micro program
21	PRG-CK	I	Clock input terminal for micro program data This reads in PRG-DT data every last transition
22	D0	I/O	External D-RAM data input/output terminal This inputs "L" to D0-D3 when using two D-RAMs.
23	D1		
24	D2		
25	D3		
26	D4		
27	D5		
28	D6		
29	D7		
30	VSS2		GND side power terminal, external short circuit with pin 6.
31	D8	I/O	External D-RAM data input/output terminal This inputs "L" to D0-D3 when using two D-RAMs.
32	D9		
33	D10		
34	D11		
35	CAS	O	CAS signal output terminal for external D-RAM
36	WE	O	WE signal output terminal for external D-RAM
37	RAS	O	RAS signal output terminal for external D-RAM
38	A0	0	External D-RAM address output terminal, A0 : LSB A8 is opened when 256 kD-RAM is in use.
39	A1		
40	A2		
41	A3		
42	VDD	-	+ side power terminal, +4.5V - +5.5V (Vss standard)

**SECTION 3  
DISASSEMBLY**

REMOVAL OF CASE

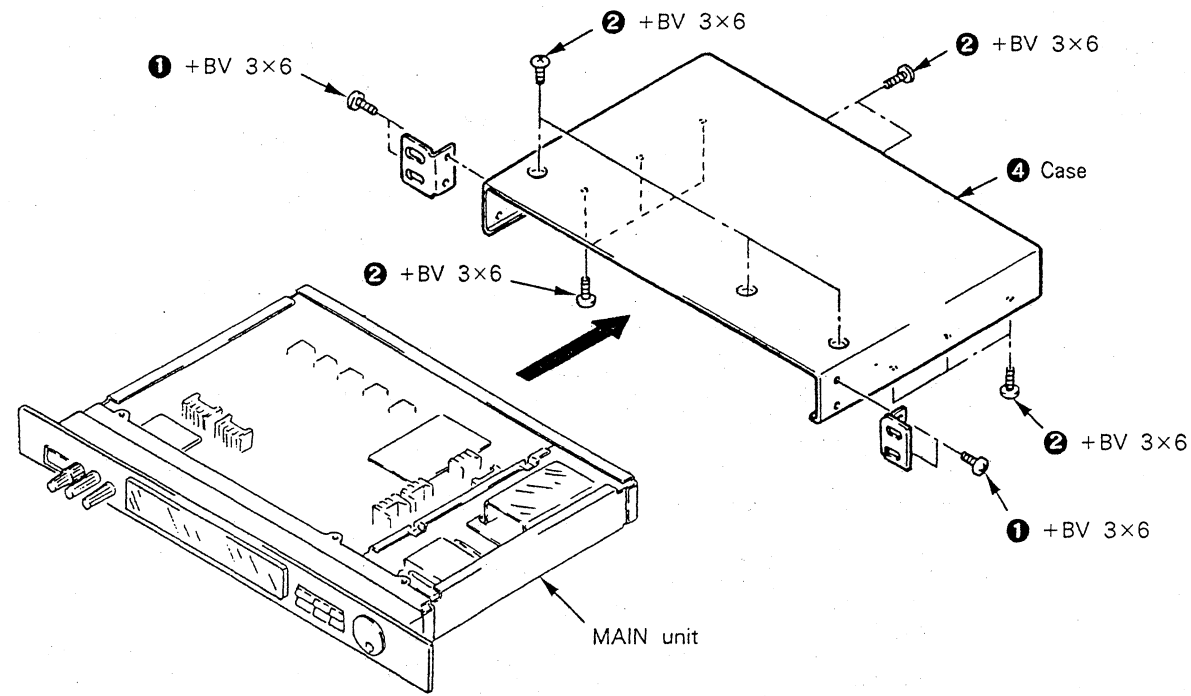

**SECTION 4  
ADJUSTMENT**

LED Level Adjustment

Setting :

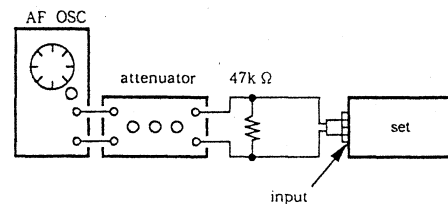

Adjusting method :

1. INPUT Volume : MAX
2. Input -30dBs, 1kHz signal to UN BALANCE input.
3. Adjust RV401 (CH-1) and RV451 (CH-2) so that the LED display of the level meter lights until 0dB.

Adjusting points : MAIN Board

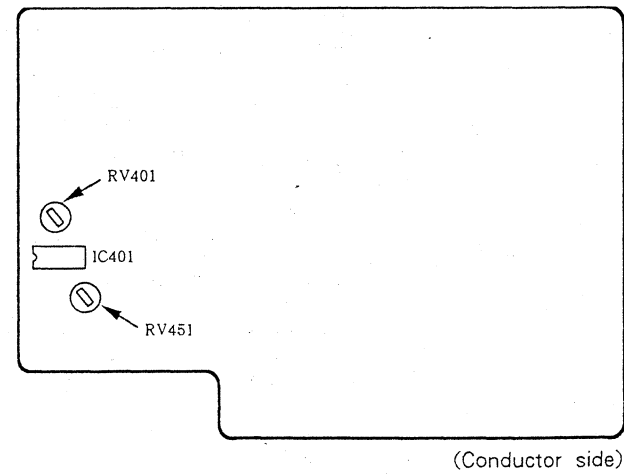

**5-1. BLOCK DIAGRAM**

**SECTION 5  
DIAGRAMS**

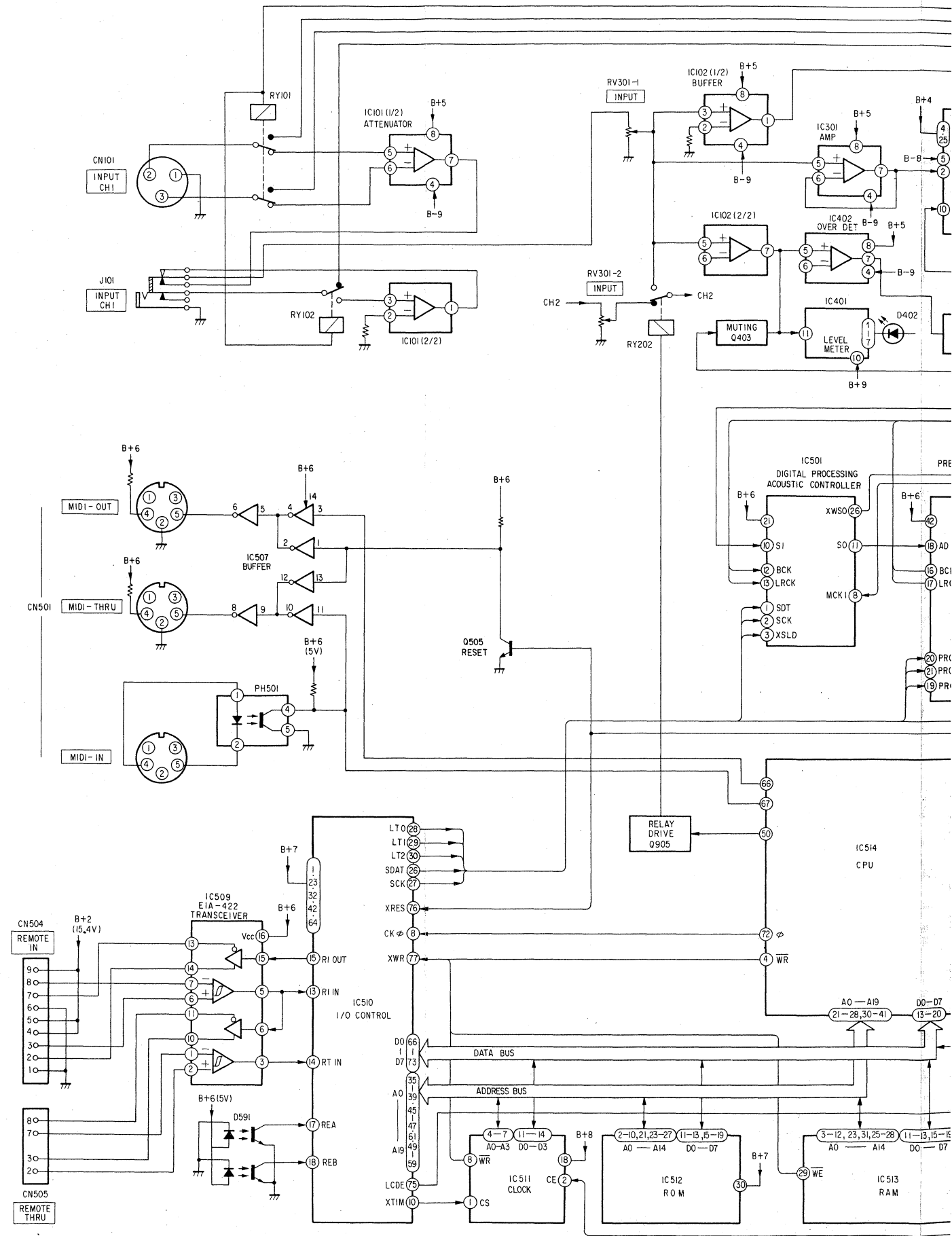

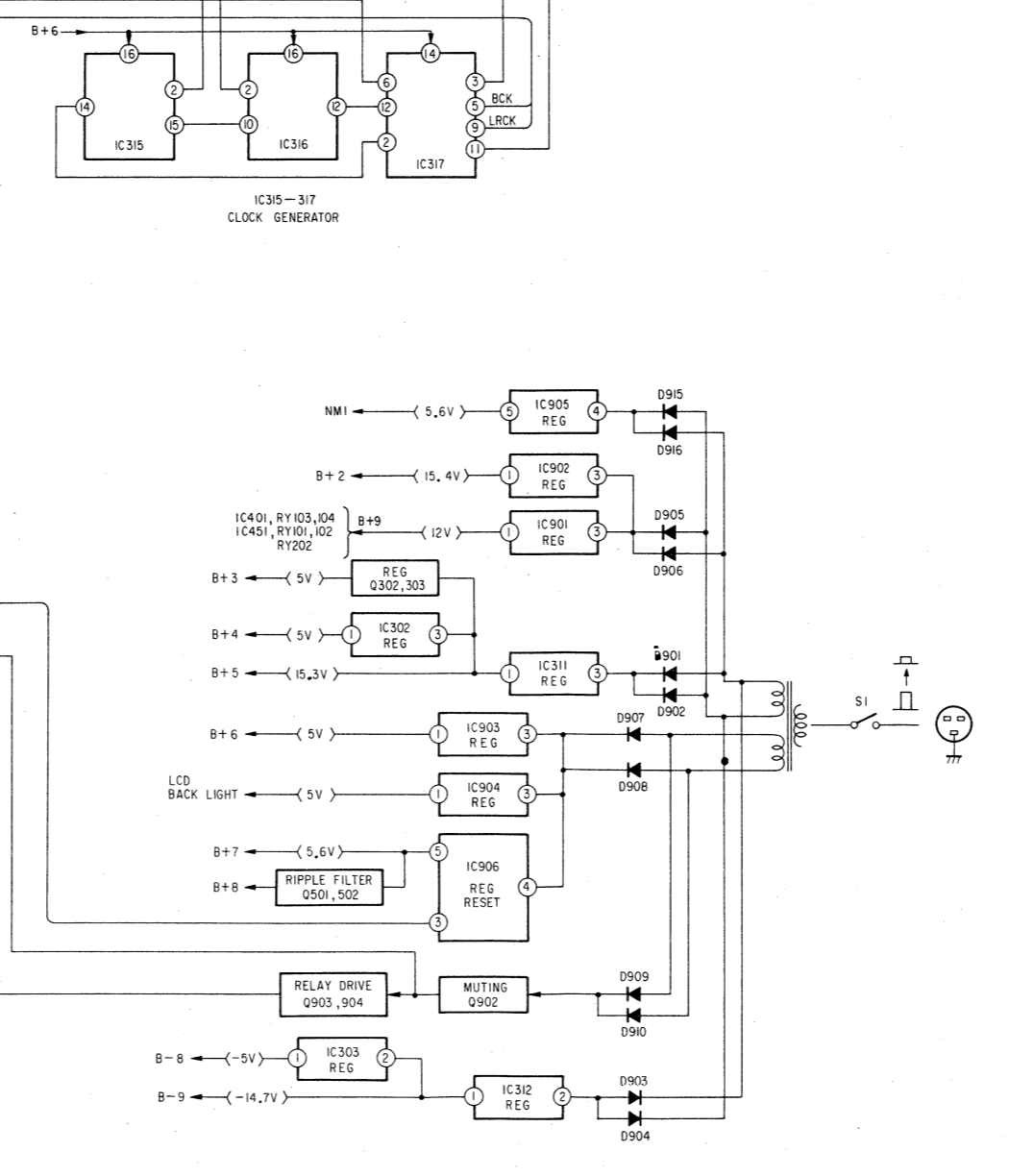
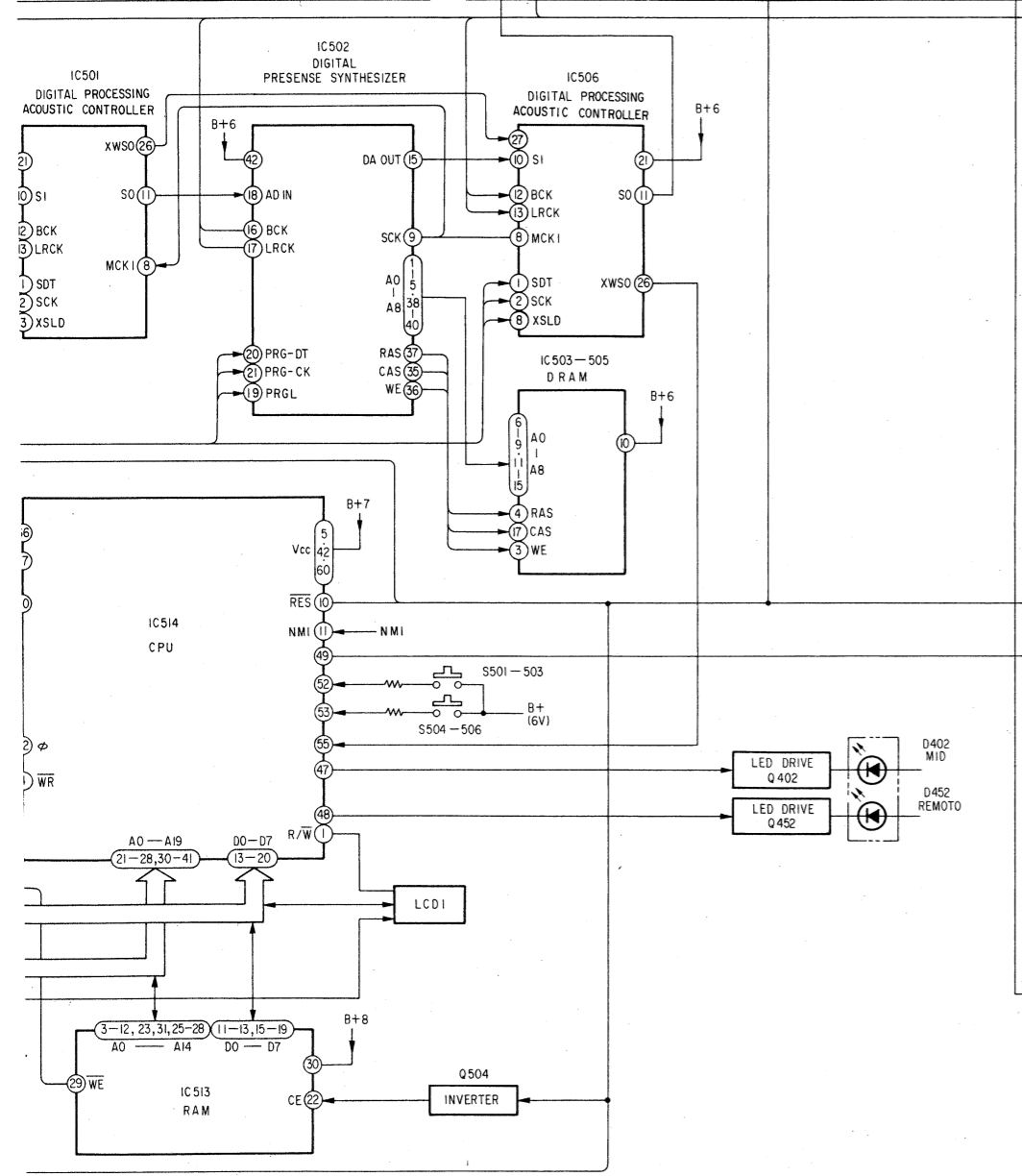
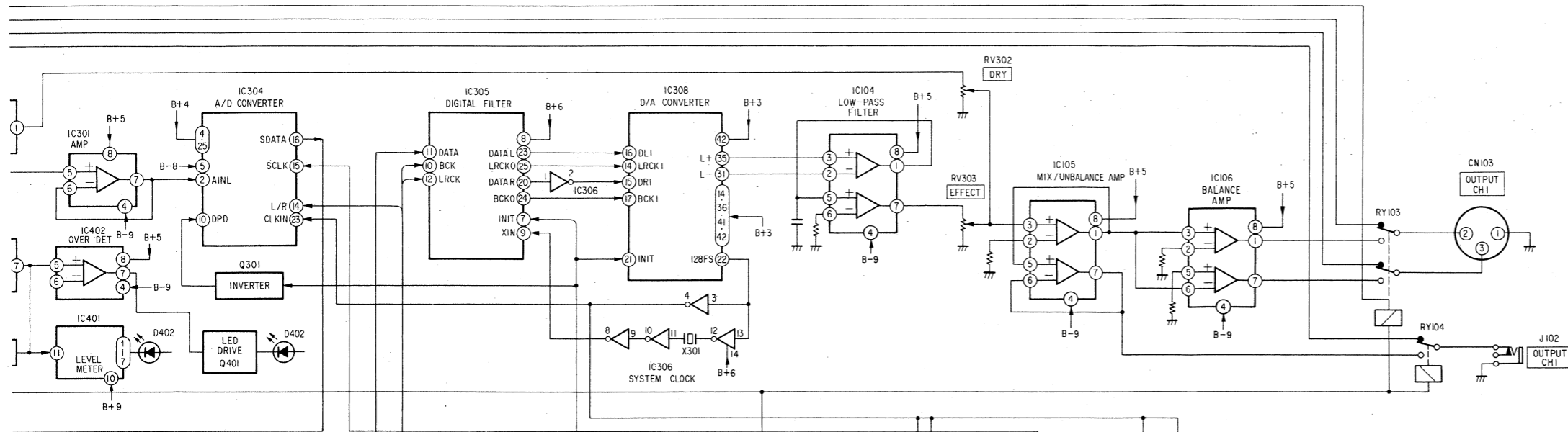

• SEMICONDUCTOR LEAD LAYOUTS

CXD2552Q-1

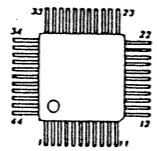

2SD1944-K



DTC114ES  
DTC144ES



2SK161GR



2SA1175-HFE  
2SC2785-HFE

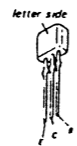

PC900

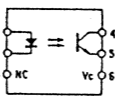
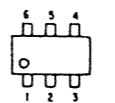

2SC2878B



2SD773-4



Note :

- : parts extracted from the component side.
- : parts mounted on the conductor side.
- : Through hole.
- ▨ : Pattern on the side which is seen.
- ▩ : Pattern of the rear side.

• SEMICONDUCTOR LOCATION

Ref. No.	Location	Ref. No.	Location
IC101	E-16	Q902	F-6
IC102	F-16	Q903	G-6
IC104	G-13	Q904	F-6
IC105	E-13	Q905	F-6
IC106	D-13		
IC201	E-14	D101	C-16
IC202	F-14	D102	C-15
IC204	G-11	D104	C-13
IC205	E-11	D105	C-12
IC206	D-11	D201	C-14
IC301	G-14	D202	D-14
IC302	H-15	D204	C-11
IC303	I-15	D301	G-14
IC304	H-14	D302	G-14
IC305	J-11	D303	G-14
IC306	I-13	D304	G-14
IC308	I-12	D305	I-13
IC311	J-15	D306	I-13
IC312	J-14	D307	I-11
IC315	J-9	D401	G-16
IC316	I-9	D402	J-18
IC317	I-9	D451	G-16
IC401	H-16	D452	K-18
IC402	G-16	D501	C-7
IC451	I-16	D502	B-7
IC501	K-8	D503	C-7
IC502	H-8	D504	C-7
IC503	H-8	D505	B-6
IC504	I-8	D506	C-7
IC505	I-8	D507	B-6
IC506	K-9	D508	C-7
IC507	B-9	D509	B-5
IC509	C-6	D510	C-5
IC510	D-19	D511	B-5
IC511	D-21	D512	C-5
IC512	F-20	D513	C-5
IC513	G-20	D514	B-5
IC514	H-19	D515	C-5
IC901	I-6	D516	C-5
IC902	H-6	D517	G-21
IC903	D-6	D522	B-10
IC904	D-5	D591	B-21
IC905	F-5	D901	K-6
IC906	E-5	D902	K-6
		D903	K-6
Q301	I-15	D904	K-6
Q302	I-13	D905	J-6
Q303	H-13	D906	J-6
Q401	G-16	D907	G-6
Q402	J-16	D908	G-6
Q403	H-16	D909	G-6
Q451	G-16	D910	G-5
Q452	J-16	D912	F-6
Q453	I-16	D913	E-6
Q501	G-21	D914	G-6
Q502	G-21	D915	J-6
Q503	G-21	D916	J-6
Q504	F-18	D917	D-5
Q505	B-8		

5-2. PRINTED WIRING BOARDS

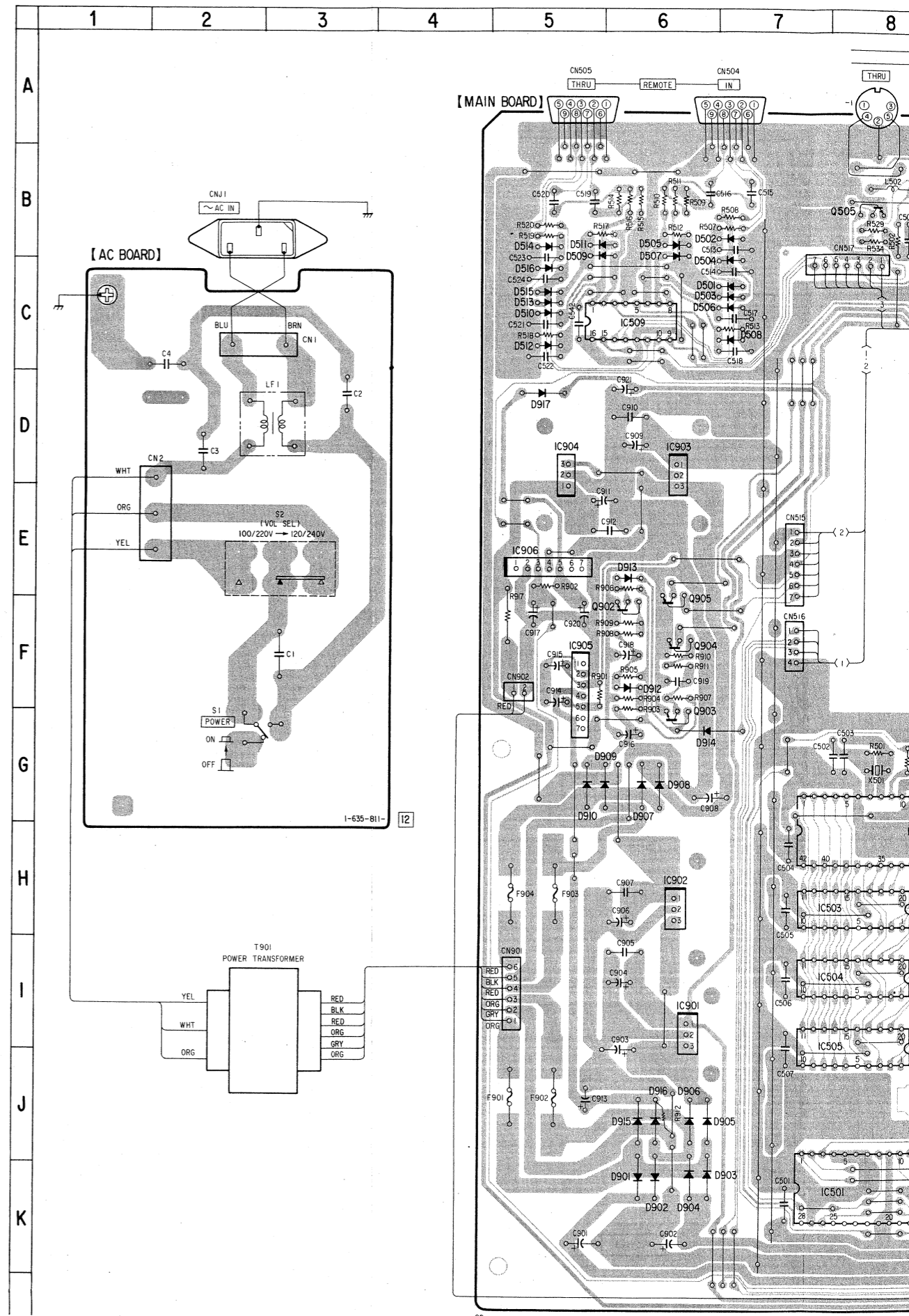

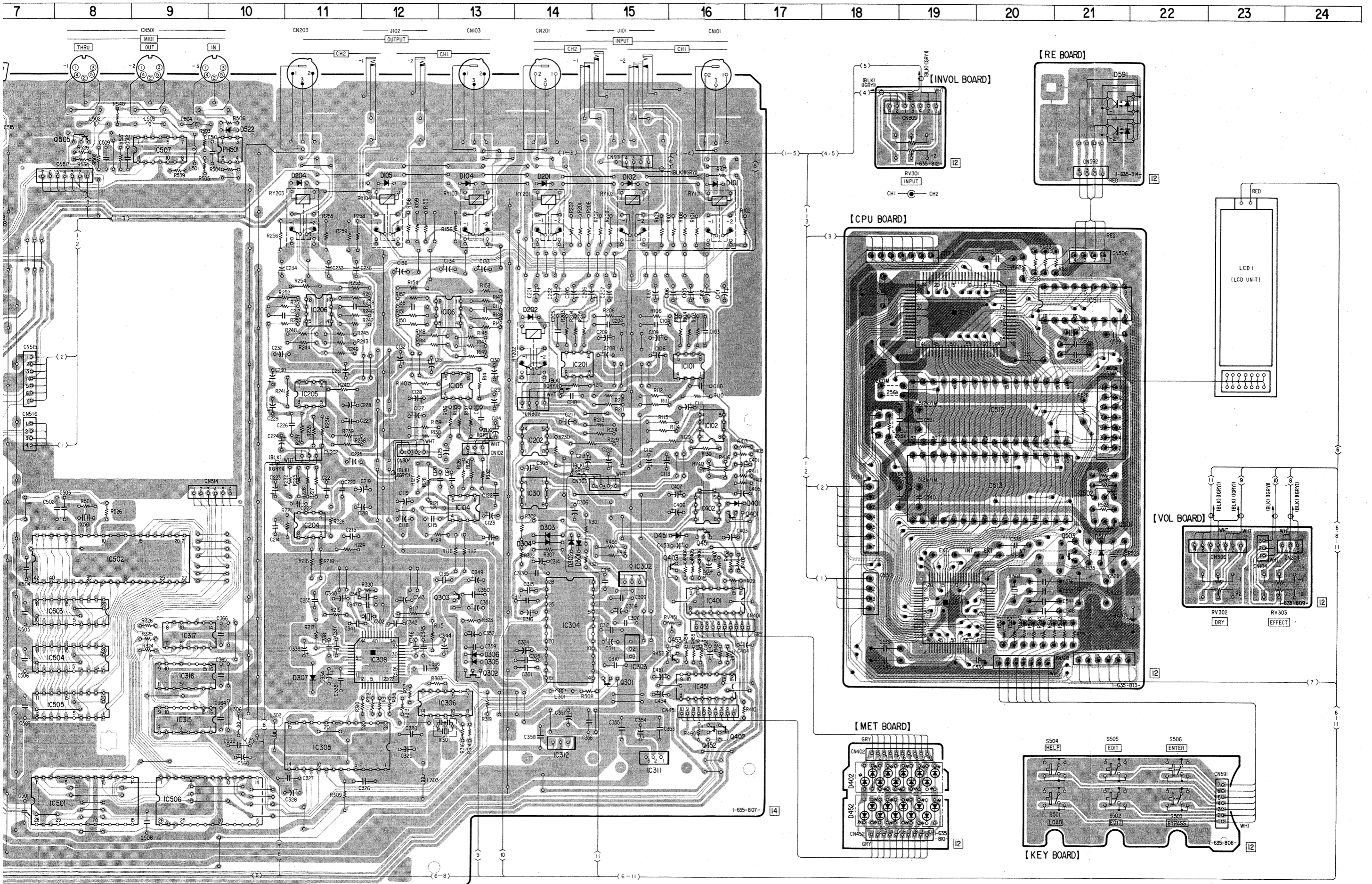

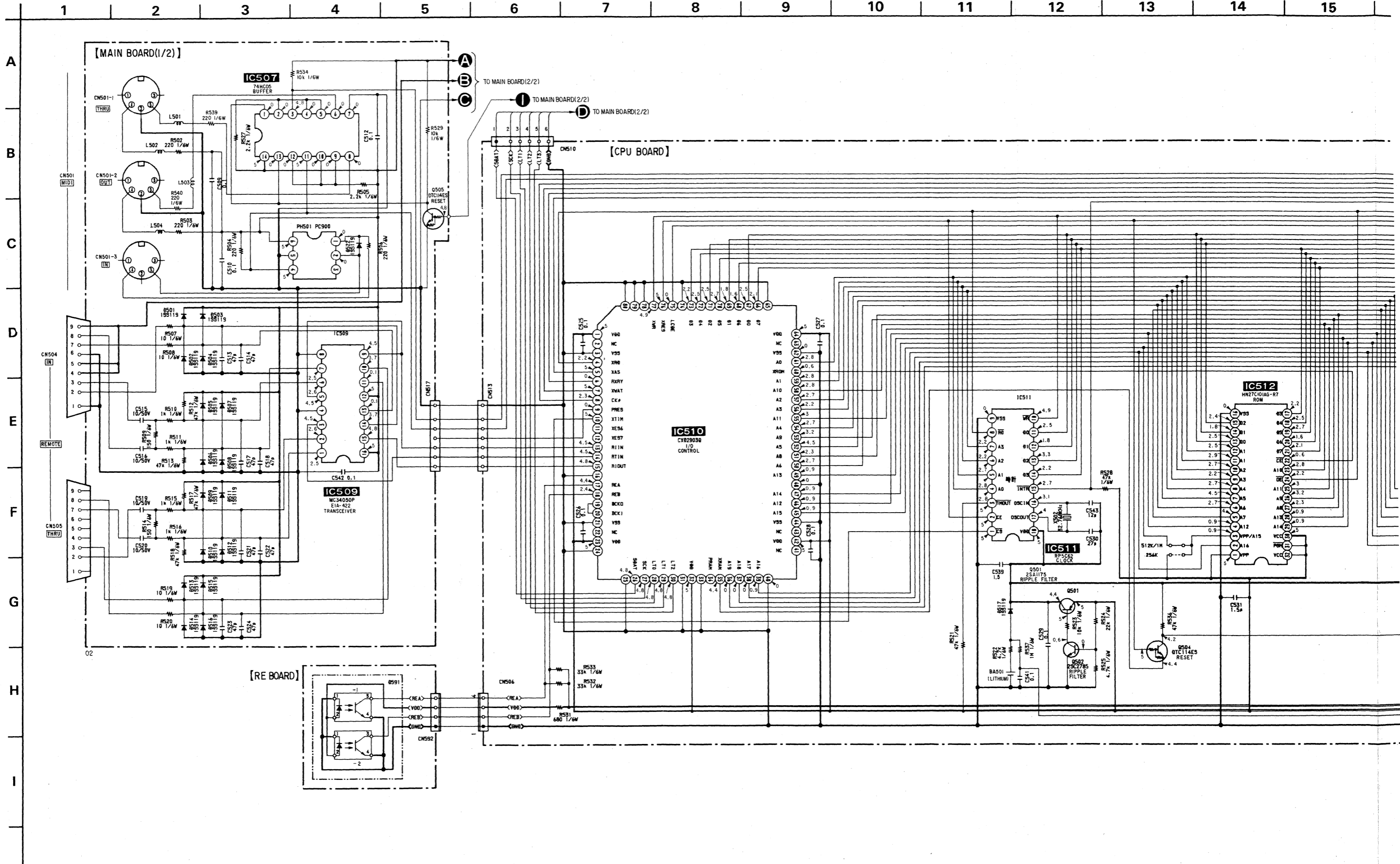

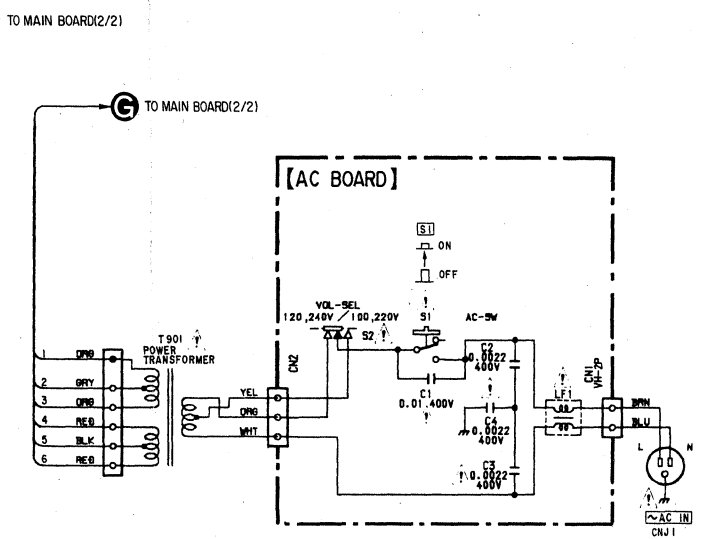
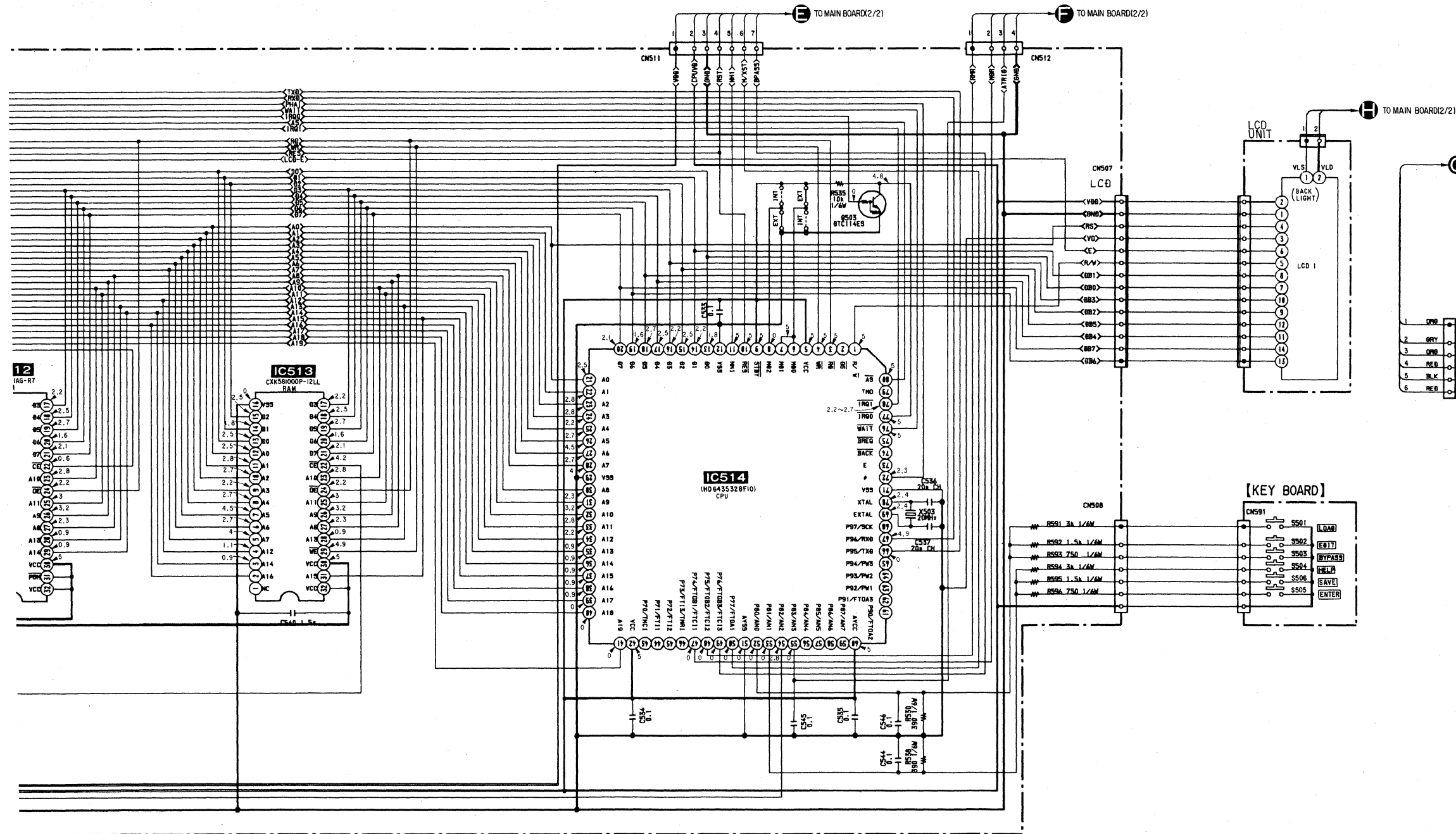



5.4. SCHEMATIC DIAGRAM(2)

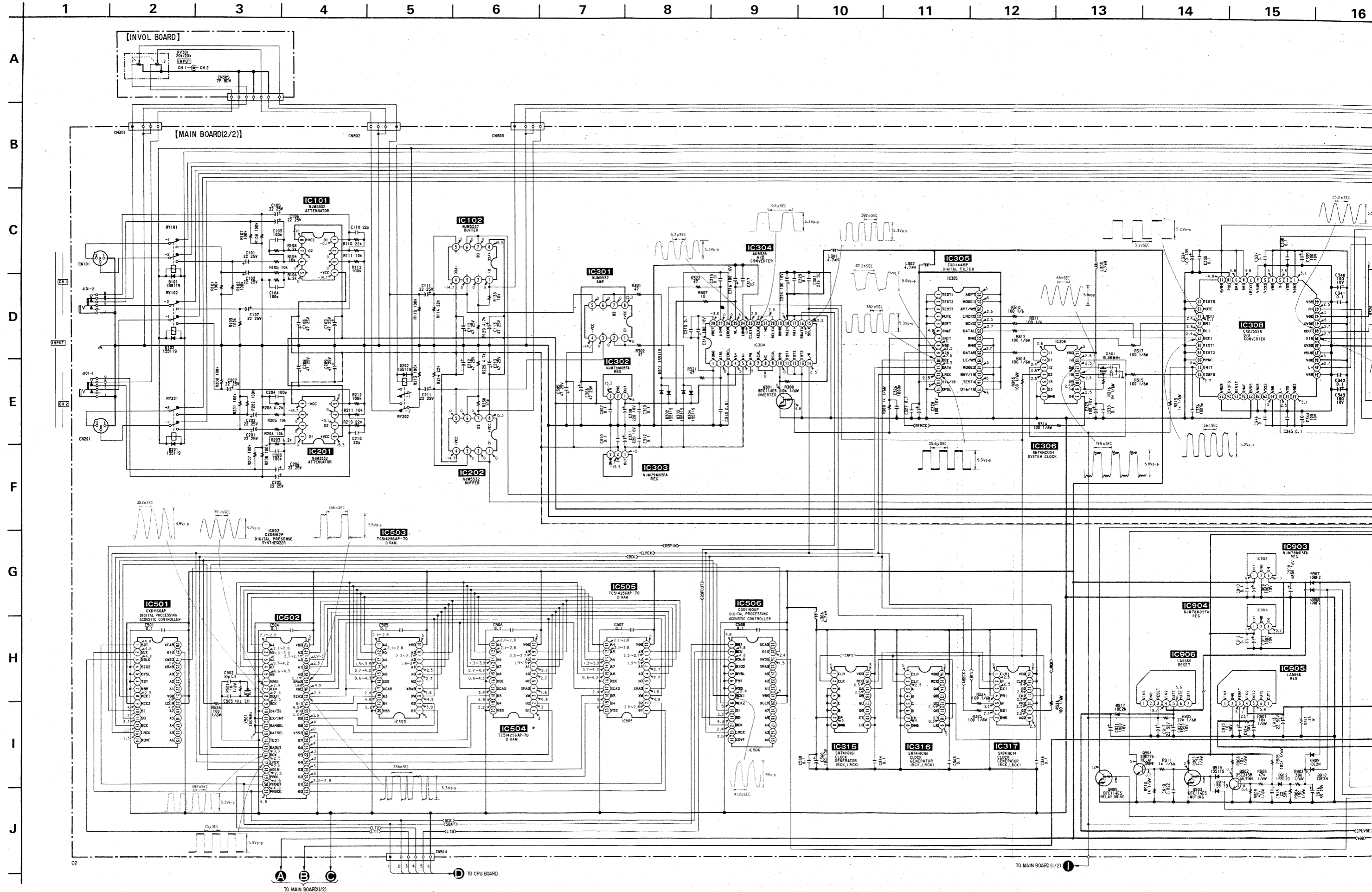

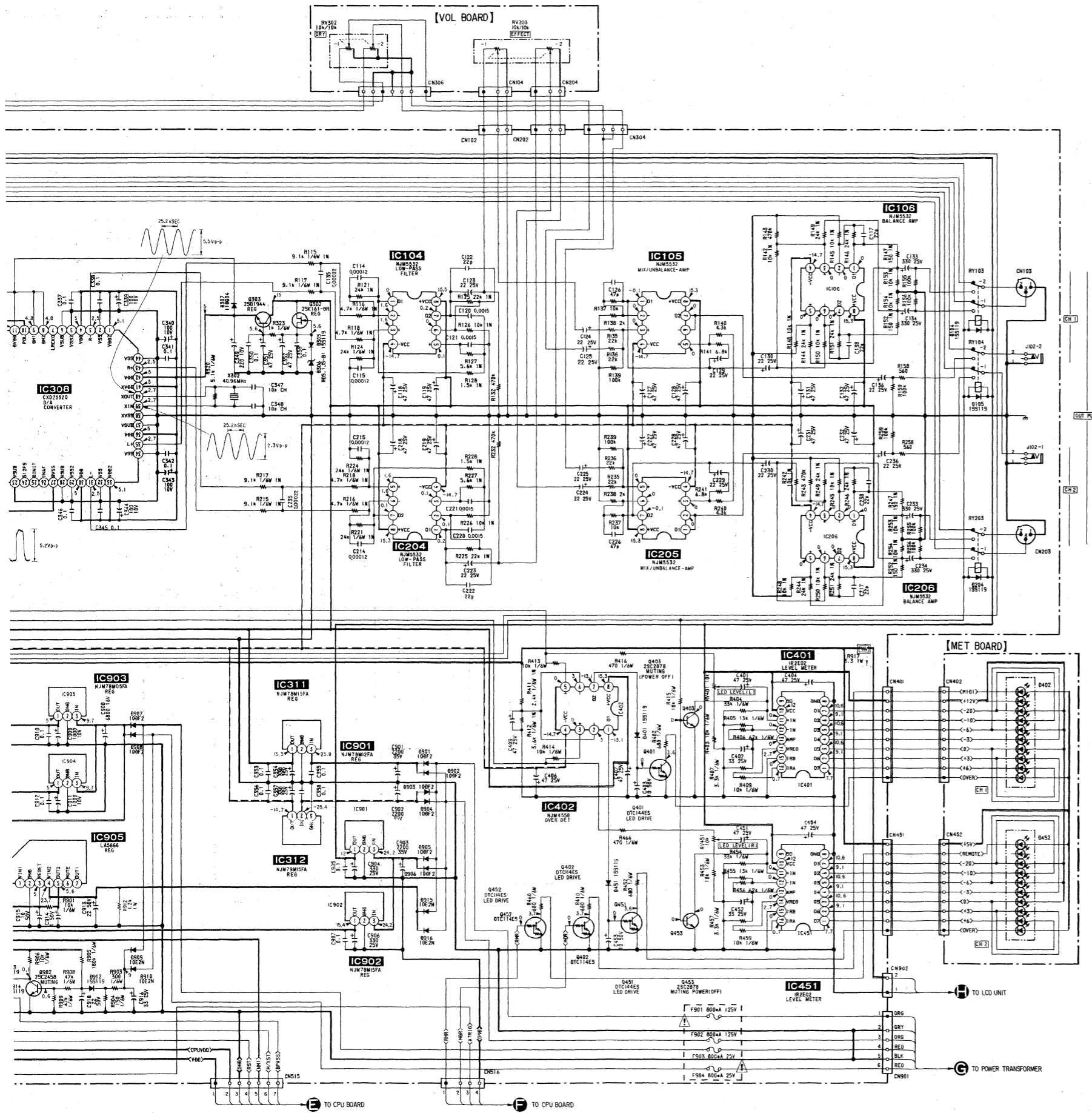

Note:

- All capacitors are in  $\mu F$  unless otherwise noted.  $pF$  :  $\mu \mu F$
- 50WV or less are not indicated except for electrolytics and tantalums.
- All resistors are in  $\Omega$  and  $\frac{1}{4}W$  or less unless otherwise specified.
- % : indicates tolerance.
- $\Delta$  : internal component.
- $\square$  : nonflammable resistor.

**Note:**  
The components identified by mark  $\Delta$  or dotted line with mark  $\Delta$  are critical for safety. Replace only with part number specified.

**Note:**  
Les composants identifiés par une marque  $\Delta$  sont critiques pour la sécurité. Ne les remplacer que par une pièce portant le numéro spécifié.

- $\text{---}$  : B+ Line
- $\text{- - -}$  : B- Line
- $\square$  : adjustment for repair.
- Voltage and waveforms are dc with respect to ground under no-signal conditions.
- Voltages are taken with a VOM (Input impedance  $10M \Omega$ ). Voltage variations may be noted due to normal production tolerances.
- Waveforms are taken with a oscilloscope. Voltage variations may be noted due to normal production tolerances.

5-5. IC BLOCK DIAGRAMS

IC104 etc. NJM5532D-D

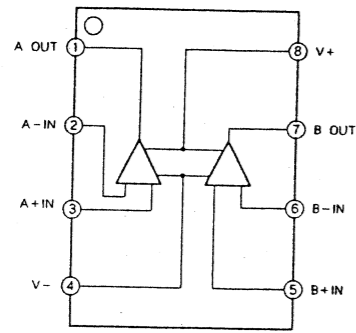

IC304 AK5328

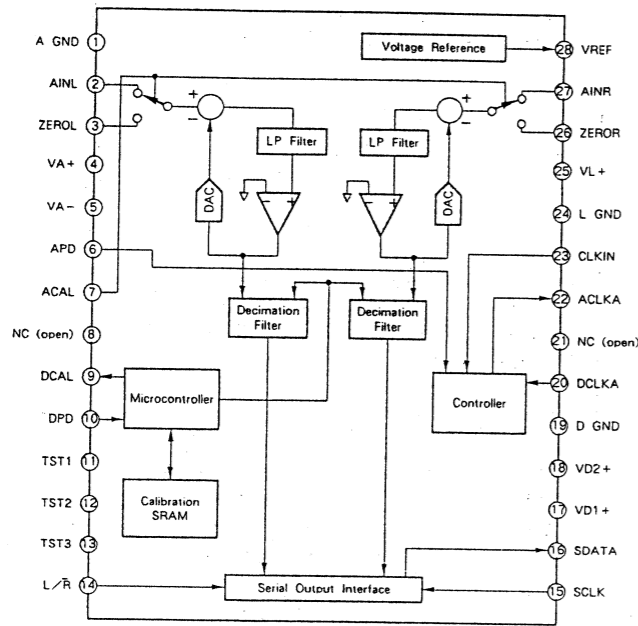

IC306 LA5665

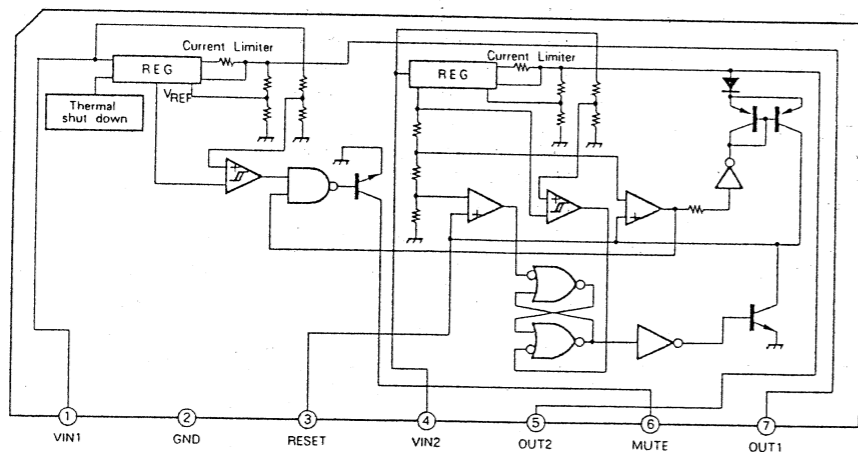

IC305 CXD1144BP

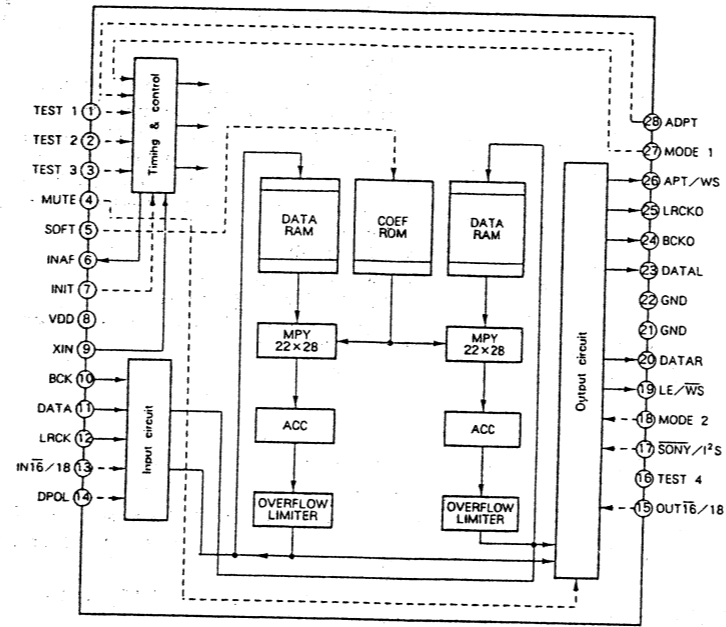

IC306 74HCU04

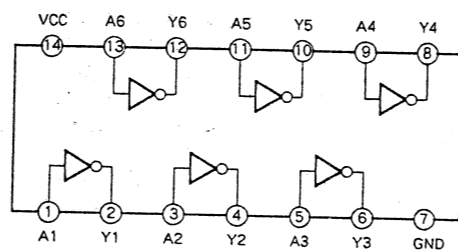

IC308 CXD2552Q

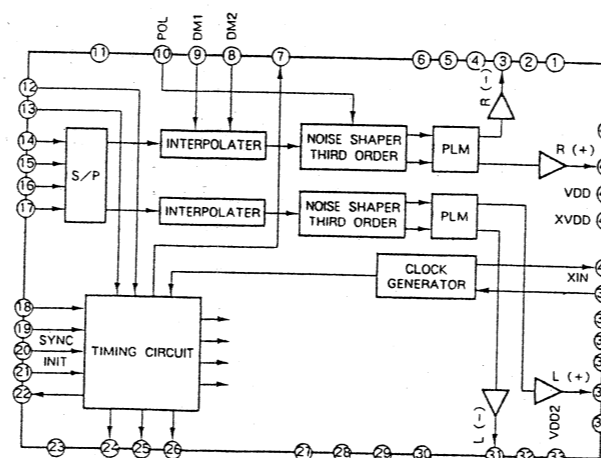

IC315. 316 74HC161

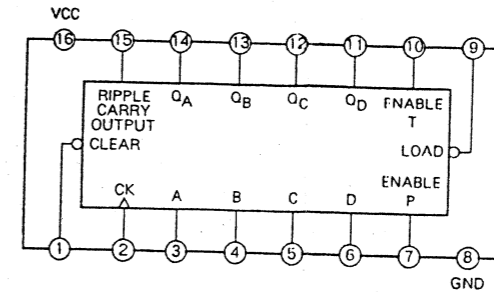

IC317 74HC74/AC74

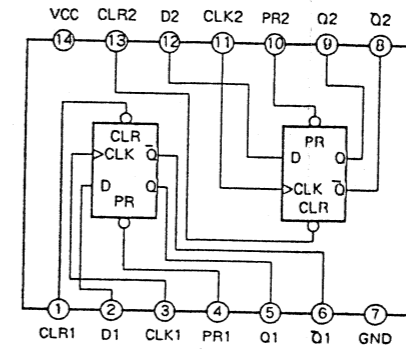

IC401, 451 IR2E02

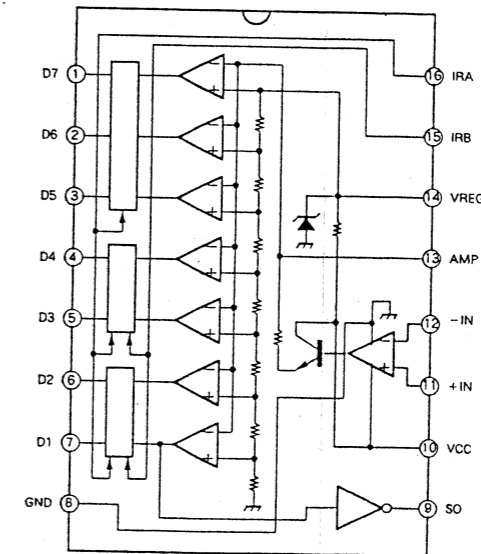

IC502 CXD8162P

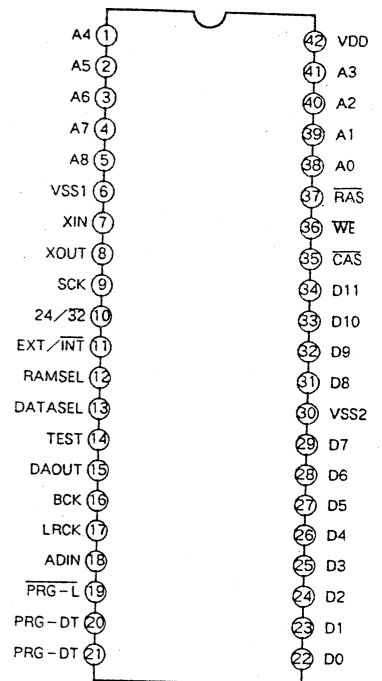

IC507 74HC05

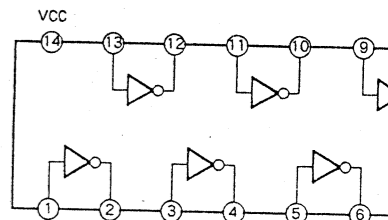

IC510 CXD2903Q

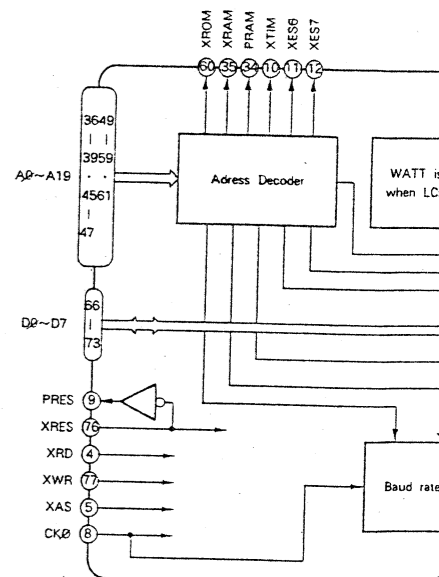

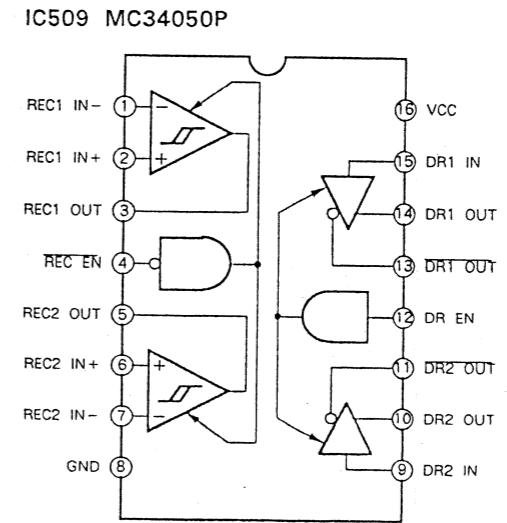
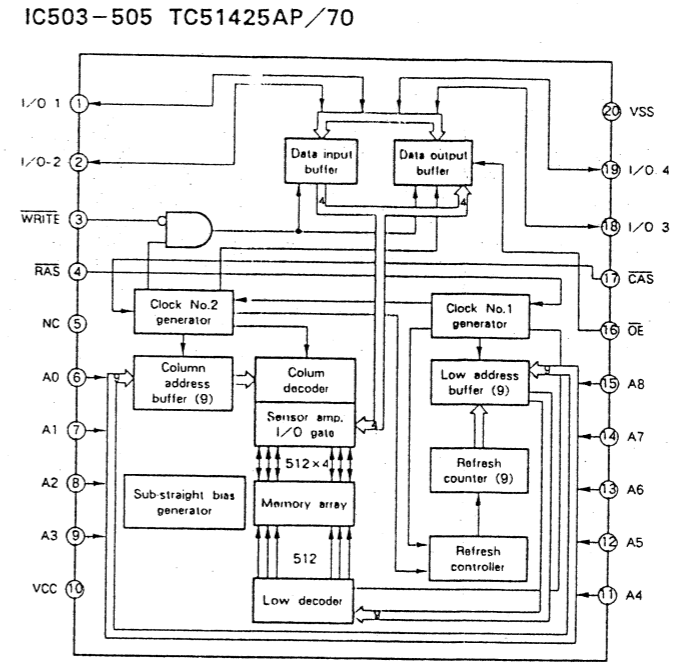
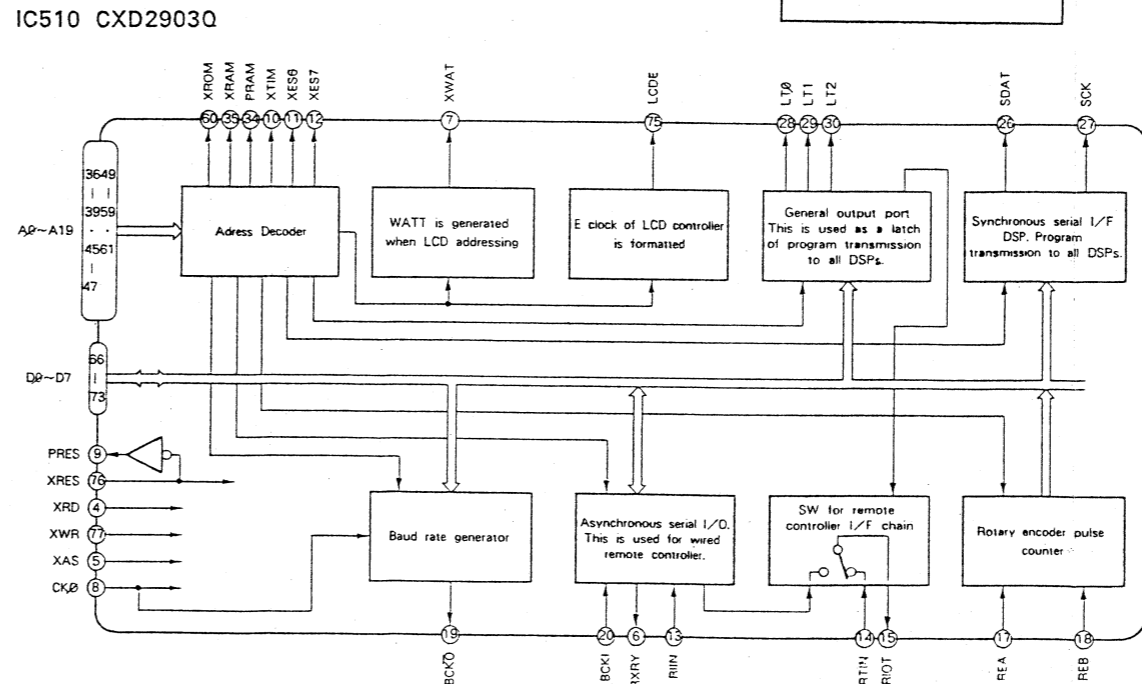
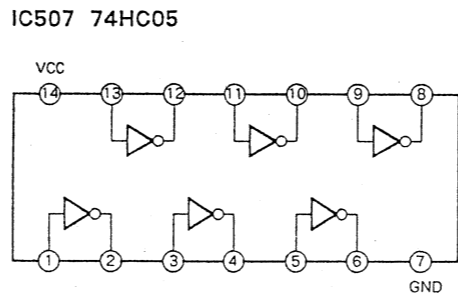
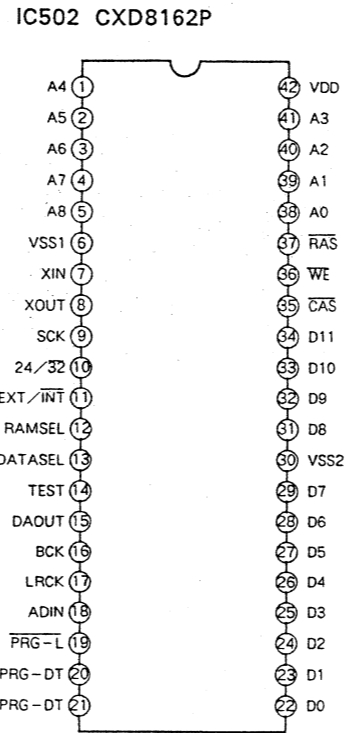
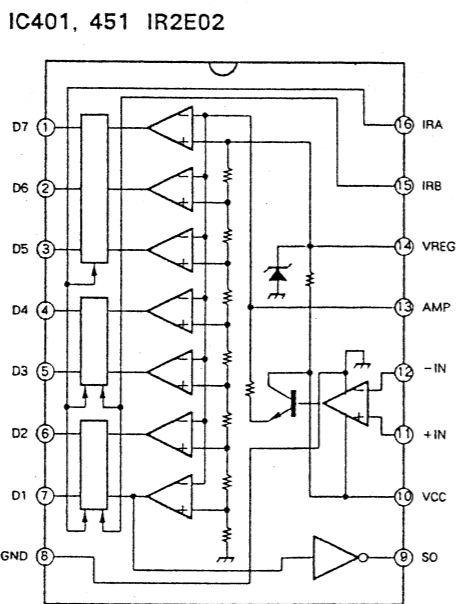
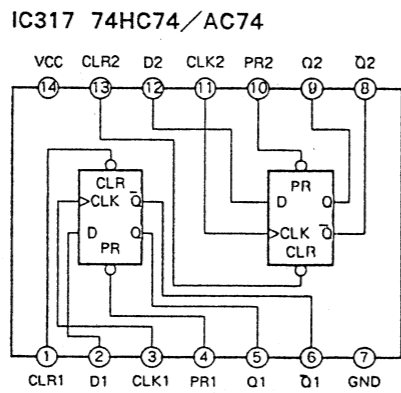
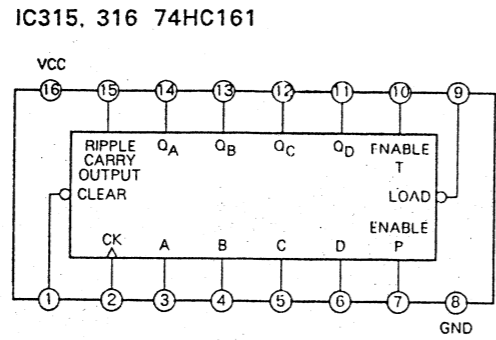
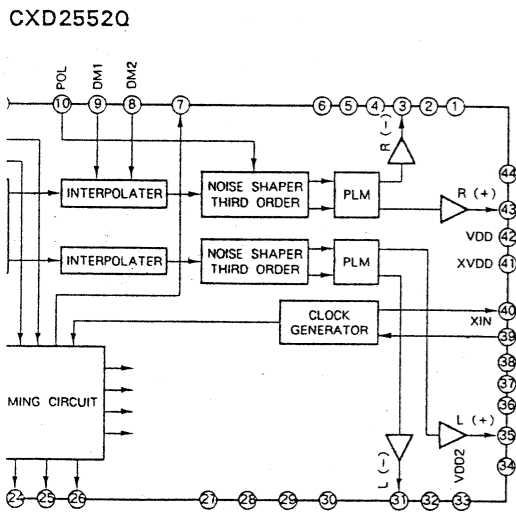
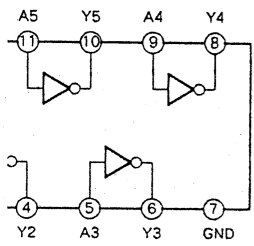
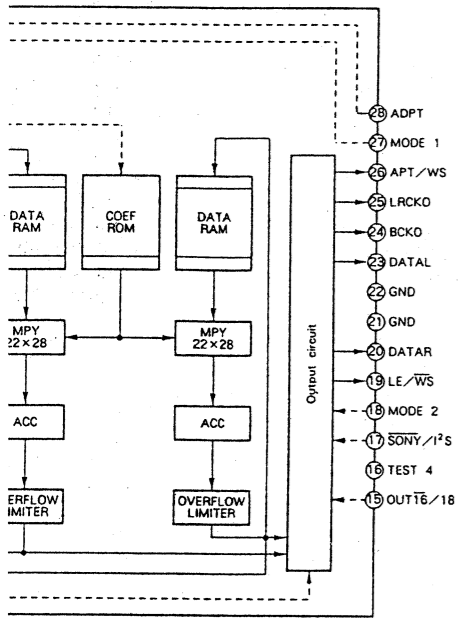

## SECTION 6 EXPLODED VIEWS

**NOTE:**

- -XX, -X mean standardized parts, so they may have some differences from the original one.
- The construction parts of an assembled part are indicated with a collation number in the remark column.
- Color indication of Appearance Parts Example:  
KNOB, BALANCE (WHITE)...(RED)

↑                    ↑  
Parts color    Cabinet's color

- Items marked "\*" are not stocked since they are seldom required for routine service. Some delay should be anticipated when ordering these items.
- The mechanical parts with no reference number in the exploded views are not supplied.
- Hardware (#mark) list is given in the last of this parts list.

The components identified by mark or dotted line with mark are critical for safety. Replace only with part number specified.

Les composants identifiés par une marque sont critiques pour la sécurité. Ne les remplacer que par une pièce portant le numéro spécifié.

**6.1. MAIN SECTION-1**

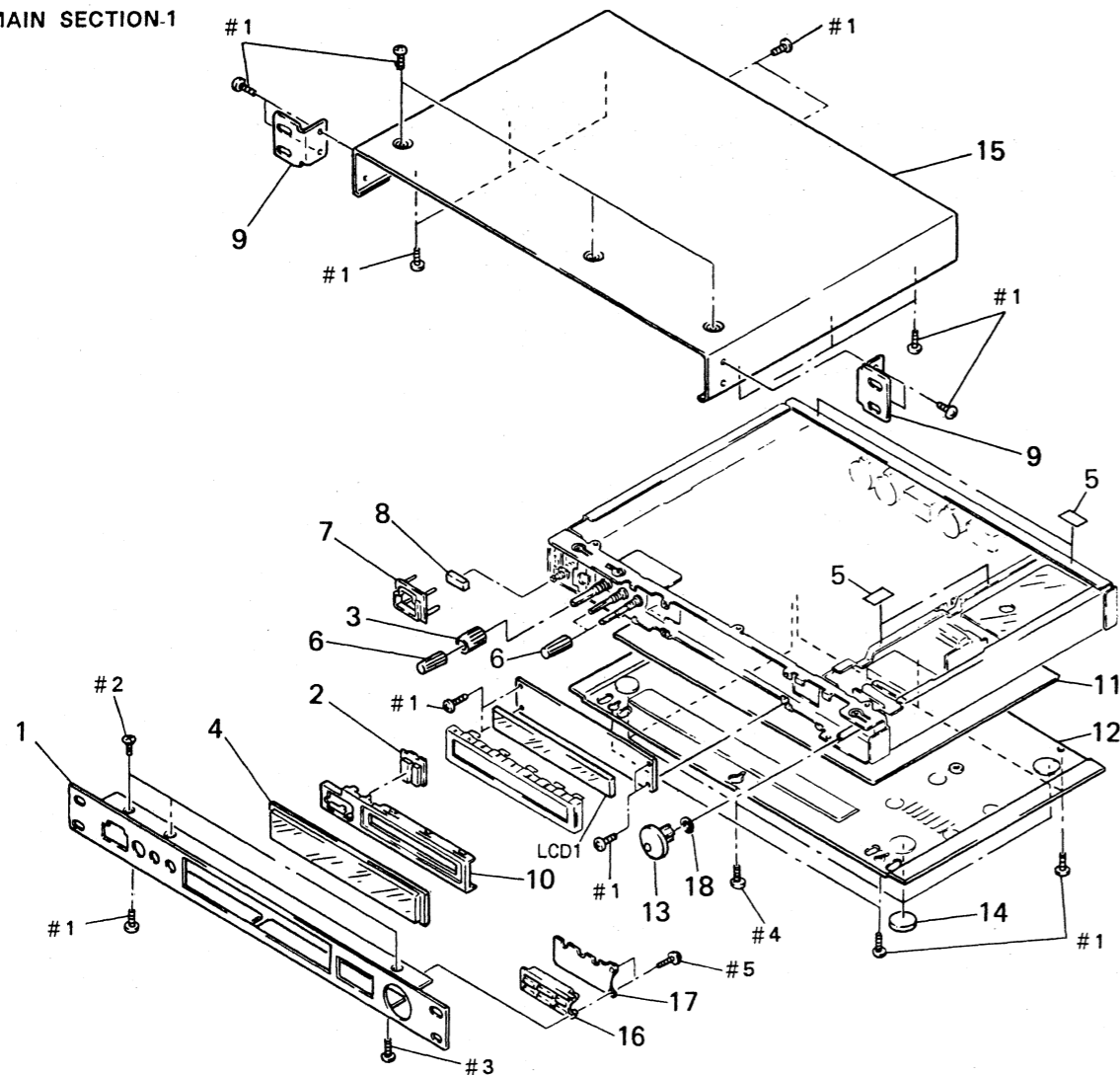

Ref. No.	Part No.	Description	Remark	Ref. No.	Part No.	Description	Remark
1	* 4-941-151-11	PANEL		11	* 4-916-327-01	SHEET, INSULATING	
2	* 1-635-810-11	MET BOARD		12	* 4-916-320-01	PLATE, BOTTOM	
3	4-941-136-01	KNOB (B)		13	4-941-138-01	KNOB (RE)	
4	* 4-941-144-11	PLATE, INDICATION		14	* 4-907-980-01	FOOT	
5	3-831-441-XX	SPACER		15	4-916-342-11	CASE (US, Canadian)	
6	4-941-142-01	KNOB (A)		15	4-916-342-21	CASE (AEP, UK, E)	
7	4-941-139-01	ESCUTCHEON (A)		16	X-4941-028-2	BUTTON ASSY	
8	4-922-921-21	BUTTON (POWER)		17	* 1-635-808-11	KEY BOARD	
9	* 4-916-305-01	REINFORCEMENT		18	4-941-141-01	STOPPER (RE)	
10	4-941-150-01	ESCUTCHEON (B)		LCD1	1-809-076-11	DISPLAY PANEL, LIQUID CRYSTAL	

**6.2. MAIN SECTION-2**

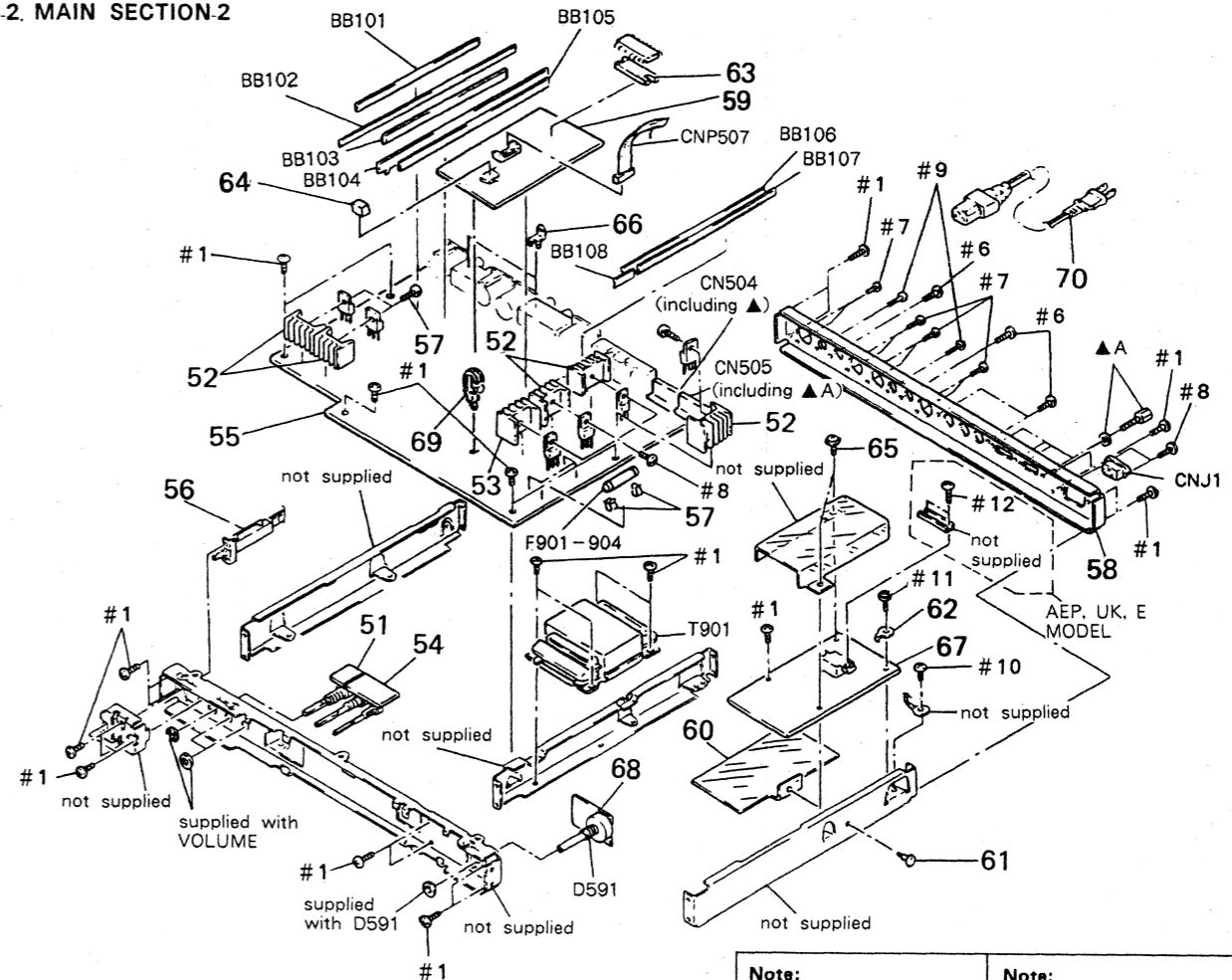

Ref. No.	Part No.	Description	Remark
51	* 1-635-812-11	INVOL BOARD	
52	* 4-921-402-21	HEAT SINK	
53	* 4-363-146-00	HEAT SINK, V. OUT	
54	* 1-635-809-11	VOL BOARD	
55	* A-4341-479-A	MAIN BOARD, COMPLETE	
56	1-572-490-21	SWITCH, PUSH (AC POWER)	
57	* 1-533-213-31	HOLDER, FUSE	
58	* 4-941-146-01	PANEL, BACK	
59	* A-4341-480-A	CPU BOARD, COMPLETE	
60	* 4-916-303-01	SHEET, INSULATING	
61	* 3-531-576-51	RIVET	
62	* 4-870-539-00	PLATE, GROUND	
63	1-540-107-11	SOCKET, IC 32P	
64	9-911-849-XX	CUSHION	
65	4-886-821-01	SCREW, S TIGHT, +PTTWH 3X6	
66	* 4-916-318-01	PLATE, GROUND	
67	* 1-635-811-11	AC BOARD	
68	* 1-635-814-11	RE BOARD	
69	* 3-697-708-01	CLAMP (B), HARNESS	
70	1-557-377-11	COAD, POWER (US, Canadian)	
70	1-590-910-11	COAD, SET, POWER (AEP, UK, E)	

Ref. No.	Part No.	Description	Remark
BB101	* 1-560-242-71	BUS BAR 6P	
BB102	* 1-560-242-41	BUS BAR 11P	
BB103	* 1-560-242-51	BUS BAR 7P	
BB104	* 1-560-242-41	BUS BAR 11P	
BB105	* 1-560-242-91	BUS BAR 10P	
BB106	* 1-560-242-41	BUS BAR 11P	
BB107	* 1-560-242-41	BUS BAR 11P	
BB108	* 1-560-242-61	BUS BAR 2P	
CN504	1-568-200-21	SOCKET, CONNECTOR 9P (REMOTE IN)	
CN505	1-568-200-21	SOCKET, CONNECTOR 9P (REMOTE THRU)	
CNJ1	* 1-580-375-21	INLET 3P (AC IN)	
CNP507	* 1-575-940-11	LEAD (WITH CONNECTOR)	
D591	1-466-386-11	DIODE ENCODER, ROTARY	
F901	1-532-215-00	FUSE, TIME-LAG (AEP, UK, E)	
F901	1-532-739-11	FUSE, GLASS TUBE (US, Canadian)	
F902	1-532-215-00	FUSE, TIME-LAG (AEP, UK, E)	
F902	1-532-739-11	FUSE, GLASS TUBE (US, Canadian)	
F903	1-532-215-00	FUSE, TIME-LAG (AEP, UK, E)	
F903	1-532-739-11	FUSE, GLASS TUBE (US, Canadian)	
F904	1-532-215-00	FUSE, TIME-LAG (AEP, UK, E)	
F904	1-532-739-11	FUSE, GLASS TUBE (US, Canadian)	
T901	1-450-176-11	TRANSFORMER, POWER (US, Canadian)	
T901	1-450-690-11	TRANSFORMER, POWER (AEP, UK, E)	

**CPU**

**NOTE:**

- Due to the part parts si compon
- -XX, - they m the orig
- RESIST( All resis METAL METAL F: nonfl

Ref. No.

BA501

C525  
C526  
C527  
C528  
C529

C530  
C531  
C533  
C534  
C535

C536  
C537  
C539  
C540  
C541

C543  
C544  
C545  
C546

CN506 \* 1  
CN507 \* 1  
CN508 \* 1  
CN510 1

6.2. MAIN SECTION-2

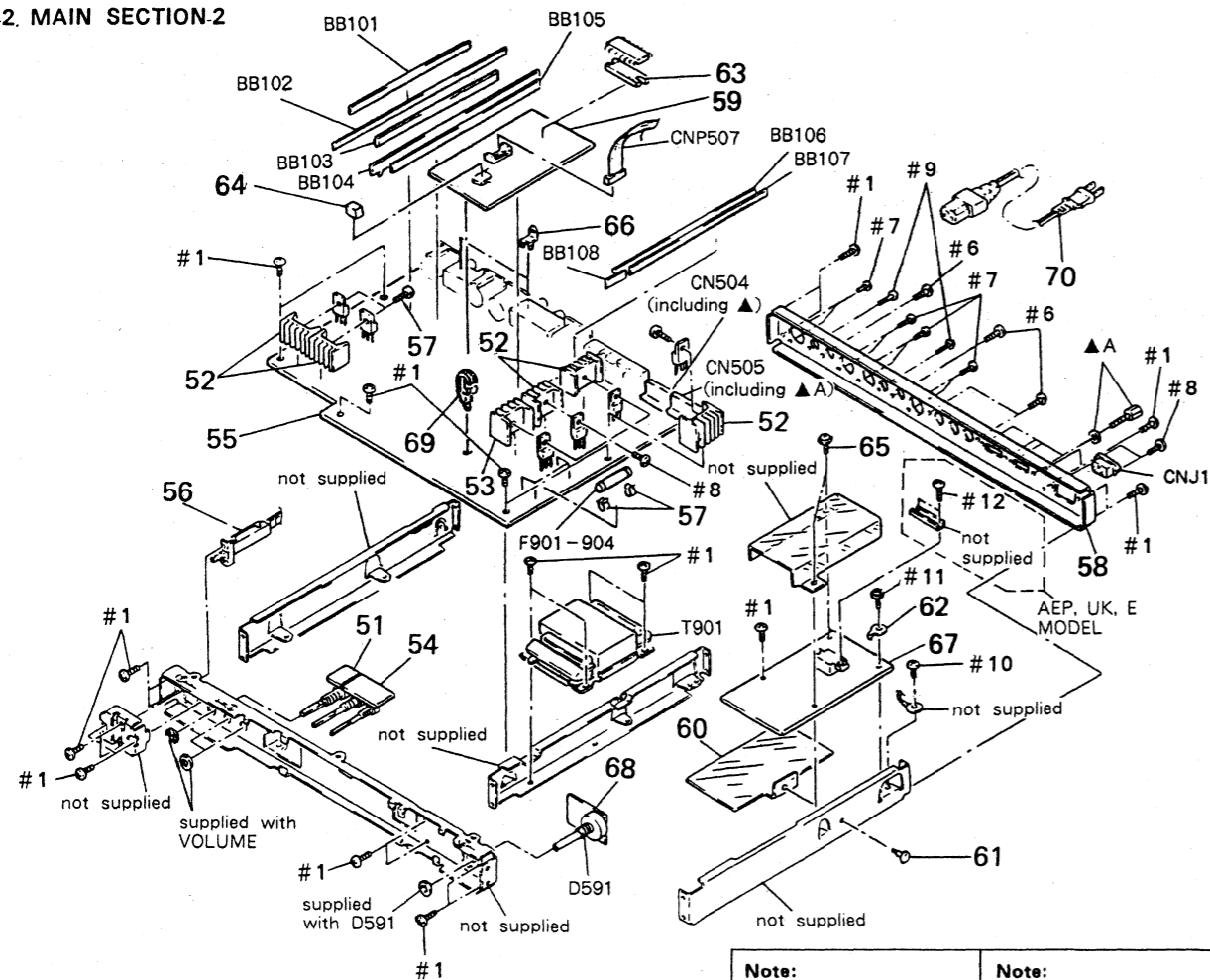

**Note:**  
The components identified by mark  $\Delta$  or dotted line with mark  $\Delta$  are critical for safety. Replace only with part number specified.

**Note:**  
Les composants identifiés par une marque  $\Delta$  sont critiques pour la sécurité. Ne les remplacer que par une pièce portant le numéro spécifié.

Ref. No.	Part No.	Description	Remark
51	* 1-635-812-11	INVOL BOARD	
52	* 4-921-402-21	HEAT SINK	
53	* 4-363-146-00	HEAT SINK, V. OUT	
54	* 1-635-809-11	VOL BOARD	
55	* A-4341-479-A	MAIN BOARD, COMPLETE	
56	1-572-490-21	SWITCH, PUSH (AC POWER)	
57	* 1-533-213-31	HOLDER, FUSE	
58	* 4-941-146-01	PANEL, BACK	
59	* A-4341-480-A	CPU BOARD, COMPLETE	
60	* 4-916-303-01	SHEET, INSULATING	
61	* 3-531-576-51	RIVET	
62	* 4-870-539-00	PLATE, GROUND	
63	1-540-107-11	SOCKET, IC 32P	
64	9-911-849-XX	CUSHION	
65	4-886-821-01	SCREW, S TIGHT, +PTTWH 3X6	
66	* 4-916-318-01	PLATE, GROUND	
67	* 1-635-811-11	AC BOARD	
68	* 1-635-814-11	RE BOARD	
69	* 3-697-708-01	CLAMP (B), HARNESS	
70	$\Delta$ 1-557-377-11	COAD, POWER (US, Canadian)	
70	$\Delta$ 1-590-910-11	COAD, SET, POWER (AEP, UK, E)	

Ref. No.	Part No.	Description	Remark
BB101	* 1-560-242-71	BUS BAR 6P	
BB102	* 1-560-242-41	BUS BAR 11P	
BB103	* 1-560-242-51	BUS BAR 7P	
BB104	* 1-560-242-41	BUS BAR 11P	
BB105	* 1-560-242-91	BUS BAR 10P	
BB106	* 1-560-242-41	BUS BAR 11P	
BB107	* 1-560-242-41	BUS BAR 11P	
BB108	* 1-560-242-61	BUS BAR 2P	
CN504	1-568-200-21	SOCKET, CONNECTOR 9P (REMOTE IN)	
CN505	1-568-200-21	SOCKET, CONNECTOR 9P (REMOTE THRU)	
CNJ1	$\Delta$ * 1-580-375-21	INLET 3P (AC IN)	
CNP507	* 1-575-940-11	LEAD (WITH CONNECTOR)	
D591	1-466-386-11	DIODE ENCODER, ROTARY	
F901	$\Delta$ 1-532-215-00	FUSE, TIME-LAG (AEP, UK, E)	
F901	$\Delta$ 1-532-739-11	FUSE, GLASS TUBE (US, Canadian)	
F902	$\Delta$ 1-532-215-00	FUSE, TIME-LAG (AEP, UK, E)	
F902	$\Delta$ 1-532-739-11	FUSE, GLASS TUBE (US, Canadian)	
F903	$\Delta$ 1-532-215-00	FUSE, TIME-LAG (AEP, UK, E)	
F903	$\Delta$ 1-532-739-11	FUSE, GLASS TUBE (US, Canadian)	
F904	$\Delta$ 1-532-215-00	FUSE, TIME-LAG (AEP, UK, E)	
F904	$\Delta$ 1-532-739-11	FUSE, GLASS TUBE (US, Canadian)	
T901	$\Delta$ 1-450-176-11	TRANSFORMER, POWER (US, Canadian)	
T901	$\Delta$ 1-450-690-11	TRANSFORMER, POWER (AEP, UK, E)	

CPU

NOTE:

- Due to standardization, replacements in the parts list may be different from the parts specified in the diagrams or the components used on the set.
- XX, -X mean standardized parts, so they may have some difference from the original one.
- RESISTORS  
All resistors are in ohms  
METAL: Metal-film resistor  
METAL OXIDE: Metal Oxide-film resistor  
F: nonflammable

SECTION 7  
ELECTRICAL PARTS LIST

- Items marked "\*" are not stocked since they are seldom required for routine service. Some delay should be anticipated when ordering these items.
- SEMICONDUCTORS  
In each case, u:  $\mu$ , for example:  
uA.....:  $\mu$ A....., uPA.....:  $\mu$ PA.....  
uPB.....:  $\mu$ PB....., uPC.....:  $\mu$ PC.....  
uPD.....:  $\mu$ PD.....
- CAPACITORS  
uF:  $\mu$ F
- COILS  
uH:  $\mu$ H

The components identified by mark  $\Delta$  or dotted line with mark  $\Delta$  are critical for safety. Replace only with part number specified.

Les composants identifiés par une marque  $\Delta$  sont critiques pour la sécurité. Ne les remplacer que par une pièce portant le numéro spécifié.

When indicating parts by reference number, please include the board name.

Ref. No.	Part No.	Description	Remark
* A-4341-480-A CPU BOARD, COMPLETE *****			
	1-540-107-11	SOCKET, IC 32P	
< BATTERY >			
BA501	1-528-225-11	BATTERY, LITHIUM	
< CAPACITOR >			
C525	1-164-159-11	CERAMIC 0.1uF	50V
C526	1-164-159-11	CERAMIC 0.1uF	50V
C527	1-164-159-11	CERAMIC 0.1uF	50V
C528	1-164-159-11	CERAMIC 0.1uF	50V
C529	1-164-159-11	CERAMIC 0.1uF	50V
C530	1-162-209-31	CERAMIC 27PF	5% 50V
C531	1-162-176-00	CERAMIC 1.5uF	25V
C533	1-164-159-11	CERAMIC 0.1uF	50V
C534	1-164-159-11	CERAMIC 0.1uF	50V
C535	1-164-159-11	CERAMIC 0.1uF	50V
C536	1-162-206-31	CERAMIC 20PF	5% 50V
C537	1-162-206-31	CERAMIC 20PF	5% 50V
C539	1-162-176-00	CERAMIC 1.5uF	25V
C540	1-162-176-00	CERAMIC 1.5uF	25V
C541	1-164-159-11	CERAMIC 0.1uF	50V
C543	1-162-201-31	CERAMIC 12PF	5% 50V
C544	1-164-159-11	CERAMIC 0.1uF	50V
C545	1-164-159-11	CERAMIC 0.1uF	50V
C546	1-164-159-11	CERAMIC 0.1uF	50V
< CONNECTOR >			
CN506	* 1-564-507-11	PLUG, CONNECTOR 4P	
CN507	* 1-580-043-11	SOCKET, CONNECTOR	
CN508	* 1-564-341-11	PIN, CONNECTOR 7P	
CN510	1-561-115-00	SOCKET, CONNECTOR 6P	

Ref. No.	Part No.	Description	Remark
CN511	* 1-561-651-00	SOCKET, CONNECTOR 7P	
CN512	1-562-087-00	SOCKET, CONNECTOR 4P	
CN513	* 1-561-651-00	SOCKET, CONNECTOR 7P	
< DIODE >			
D517	8-719-911-19	DIODE 1SS119	
< IC >			
IC510	8-759-502-92	IC CXD29030	
IC511	8-759-984-34	IC RP5C62	
IC512	8-759-709-19	IC HN27C101AG-R7	
IC513	8-752-335-19	IC CXK581000P-12LL	
IC514	8-759-323-88	IC HD6435328RA00F	
< TRANSISTOR >			
Q501	8-729-119-76	TRANSISTOR 2SA1175-HFE	
Q502	8-729-119-78	TRANSISTOR 2SC2785-HFE	
Q503	8-729-900-80	TRANSISTOR DTC114ES	
Q504	8-729-900-80	TRANSISTOR DTC114ES	
< RESISTOR >			
R521	1-259-468-11	CARBON 47K 5% 1/6W	
R522	1-259-444-11	CARBON 4.7K 5% 1/6W	
R523	1-259-452-11	CARBON 10K 5% 1/6W	
R524	1-259-460-11	CARBON 22K 5% 1/6W	
R525	1-259-444-11	CARBON 4.7K 5% 1/6W	
R528	1-259-468-11	CARBON 47K 5% 1/6W	
R530	1-259-418-11	CARBON 390 5% 1/6W	
R531	1-259-424-11	CARBON 680 5% 1/6W	
R532	1-259-464-11	CARBON 33K 5% 1/6W	
R533	1-259-464-11	CARBON 33K 5% 1/6W	
R535	1-259-452-11	CARBON 10K 5% 1/6W	
R536	1-259-468-11	CARBON 47K 5% 1/6W	
R537	1-259-500-11	CARBON 1M 5% 1/6W	
R538	1-259-418-11	CARBON 390 5% 1/6W	
R591	1-259-439-11	CARBON 3K 5% 1/6W	

CPU	MAIN
-----	------

Ref. No.	Part No.	Description	Remark			Ref. No.	Part No.	Description	Remark		
R592	1-259-432-11	CARBON	1.5K	5%	1/6W	C127	1-124-477-11	ELECT	47uF	20%	25V
R593	1-259-425-11	CARBON	750	5%	1/6W	C128	1-124-477-11	ELECT	47uF	20%	25V
R594	1-259-439-11	CARBON	3K	5%	1/6W	C129	1-126-233-11	ELECT	22uF	20%	50V
R595	1-259-432-11	CARBON	1.5K	5%	1/6W	C130	1-126-233-11	ELECT	22uF	20%	50V
R596	1-259-425-11	CARBON	750	5%	1/6W	C131	1-124-477-11	ELECT	47uF	20%	25V
< CRYSTAL >						C132	1-124-477-11	ELECT	47uF	20%	25V
X502	1-567-098-00	OSCILLATOR, CRYSTAL (32.768KHz)				C133	1-126-059-11	ELECT	330uF	20%	25V
X503	1-577-121-11	VIBRATOR, CRYSTAL (20MHz)				C134	1-126-059-11	ELECT	330uF	20%	25V
*****						C135	1-110-339-11	MYLAR	220PF	5%	50V
*****						C136	1-126-233-11	ELECT	22uF	20%	50V
*****						C138	1-162-207-31	CERAMIC	22PF	5%	50V
* A-4341-479-A MAIN BOARD, COMPLETE						C201	1-126-233-11	ELECT	22uF	20%	50V
*****						C202	1-126-233-11	ELECT	22uF	20%	50V
*****						C203	1-162-282-31	CERAMIC	100PF	10%	50V
* 1-533-213-31 HOLDER, FUSE						C204	1-162-282-31	CERAMIC	100PF	10%	50V
* 1-560-242-41 BUS BAR 11P						C205	1-126-233-11	ELECT	22uF	20%	50V
* 1-560-242-51 BUS BAR 7P						C206	1-126-233-11	ELECT	22uF	20%	50V
* 1-560-242-61 BUS BAR 2P						C207	1-126-233-11	ELECT	22uF	20%	50V
* 1-560-242-71 BUS BAR 6P						C208	1-124-477-11	ELECT	47uF	20%	25V
* 1-560-242-91 BUS BAR 10P						C209	1-124-477-11	ELECT	47uF	20%	25V
* 4-363-146-00 HEAT SINK, V. OUT						C210	1-162-207-31	CERAMIC	22PF	5%	50V
* 4-916-318-01 PLATE, GROUND						C211	1-126-233-11	ELECT	22uF	20%	50V
* 4-921-402-21 HEAT SINK						C212	1-124-477-11	ELECT	47uF	20%	25V
< CAPACITOR >						C213	1-124-477-11	ELECT	47uF	20%	25V
C101	1-126-233-11	ELECT	22uF	20%	50V	C214	1-110-336-51	MYLAR	120PF	5%	50V
C102	1-126-233-11	ELECT	22uF	20%	50V	C215	1-110-336-51	MYLAR	120PF	5%	50V
C103	1-162-282-31	CERAMIC	100PF	10%	50V	C217	1-162-207-31	CERAMIC	22PF	5%	50V
C104	1-162-282-31	CERAMIC	100PF	10%	50V	C218	1-124-477-11	ELECT	47uF	20%	25V
C105	1-126-233-11	ELECT	22uF	20%	50V	C219	1-124-477-11	ELECT	47uF	20%	25V
C106	1-126-233-11	ELECT	22uF	20%	50V	C220	1-130-473-00	MYLAR	0.0015uF	5%	50V
C107	1-126-233-11	ELECT	22uF	20%	50V	C221	1-130-473-00	MYLAR	0.0015uF	5%	50V
C108	1-124-477-11	ELECT	47uF	20%	25V	C222	1-162-207-31	CERAMIC	22PF	5%	50V
C109	1-124-477-11	ELECT	47uF	20%	25V	C223	1-126-233-11	ELECT	22uF	20%	50V
C110	1-162-207-31	CERAMIC	22PF	5%	50V	C224	1-126-233-11	ELECT	22uF	20%	50V
C111	1-126-233-11	ELECT	22uF	20%	50V	C225	1-126-233-11	ELECT	22uF	20%	50V
C112	1-124-477-11	ELECT	47uF	20%	25V	C226	1-162-215-31	CERAMIC	47PF	5%	50V
C113	1-124-477-11	ELECT	47uF	20%	25V	C227	1-124-477-11	ELECT	47uF	20%	25V
C114	1-110-336-51	MYLAR	120PF	5%	50V	C228	1-124-477-11	ELECT	47uF	20%	25V
C115	1-110-336-51	MYLAR	120PF	5%	50V	C229	1-126-233-11	ELECT	22uF	20%	50V
C117	1-162-207-31	CERAMIC	22PF	5%	50V	C230	1-126-233-11	ELECT	22uF	20%	50V
C118	1-124-477-11	ELECT	47uF	20%	25V	C231	1-124-477-11	ELECT	47uF	20%	25V
C119	1-124-477-11	ELECT	47uF	20%	25V	C232	1-124-477-11	ELECT	47uF	20%	25V
C120	1-130-473-00	MYLAR	0.0015uF	5%	50V	C233	1-126-059-11	ELECT	330uF	20%	25V
C121	1-130-473-00	MYLAR	0.0015uF	5%	50V	C234	1-126-059-11	ELECT	330uF	20%	25V
C122	1-162-207-31	CERAMIC	22PF	5%	50V	C235	1-110-339-11	MYLAR	220PF	5%	50V
C123	1-126-233-11	ELECT	22uF	20%	50V	C236	1-126-233-11	ELECT	22uF	20%	50V
C124	1-126-233-11	ELECT	22uF	20%	50V	C238	1-162-207-31	CERAMIC	22PF	5%	50V
C125	1-126-233-11	ELECT	22uF	20%	50V	C301	1-162-207-31	CERAMIC	22PF	5%	50V
C126	1-162-215-31	CERAMIC	47PF	5%	50V	C305	1-124-477-11	ELECT	47uF	20%	25V

## MAIN

Ref. No.	Part No.	Description		Remark		Ref. No.	Part No.	Description		Remark
C306	1-124-477-11	ELECT	47uF	20%	25V	C364	1-164-159-11	CERAMIC	0.1uF	50V
C307	1-164-159-11	CERAMIC	0.1uF		50V	C365	1-164-159-11	CERAMIC	0.1uF	50V
C308	1-126-176-11	ELECT	220uF	20%	10V	C366	1-164-159-11	CERAMIC	0.1uF	50V
C309	1-164-159-11	CERAMIC	0.1uF		50V	C401	1-124-477-11	ELECT	47uF	20% 25V
C310	1-164-159-11	CERAMIC	0.1uF		50V	C402	1-124-482-11	ELECT	33uF	20% 35V
C311	1-126-176-11	ELECT	220uF	20%	10V	C403	1-124-907-11	ELECT	10uF	20% 50V
C312	1-164-159-11	CERAMIC	0.1uF		50V	C404	1-124-477-11	ELECT	47uF	20% 25V
C313	1-164-159-11	CERAMIC	0.1uF		50V	C405	1-124-477-11	ELECT	47uF	20% 25V
C314	1-124-443-00	ELECT	100uF	20%	10V	C406	1-124-477-11	ELECT	47uF	20% 25V
C315	1-136-153-00	FILM	0.01uF	5%	50V	C407	1-124-477-11	ELECT	47uF	20% 25V
C316	1-124-443-00	ELECT	100uF	20%	10V	C451	1-124-477-11	ELECT	47uF	20% 25V
C317	1-164-159-11	CERAMIC	0.1uF		50V	C452	1-124-482-11	ELECT	33uF	20% 35V
C318	1-136-153-00	FILM	0.01uF	5%	50V	C453	1-124-907-11	ELECT	10uF	20% 50V
C324	1-124-443-00	ELECT	100uF	20%	10V	C454	1-124-477-11	ELECT	47uF	20% 25V
C325	1-164-159-11	CERAMIC	0.1uF		50V	C501	1-164-159-11	CERAMIC	0.1uF	50V
C326	1-162-294-31	CERAMIC	0.001uF	10%	50V	C502	1-162-199-31	CERAMIC	10PF	5% 50V
C327	1-164-159-11	CERAMIC	0.1uF		50V	C503	1-162-199-31	CERAMIC	10PF	5% 50V
C328	1-124-443-00	ELECT	100uF	20%	10V	C504	1-164-159-11	CERAMIC	0.1uF	50V
C329	1-124-443-00	ELECT	100uF	20%	10V	C505	1-164-159-11	CERAMIC	0.1uF	50V
C330	1-164-159-11	CERAMIC	0.1uF		50V	C506	1-164-159-11	CERAMIC	0.1uF	50V
C334	1-124-443-00	ELECT	100uF	20%	10V	C507	1-164-159-11	CERAMIC	0.1uF	50V
C335	1-164-159-11	CERAMIC	0.1uF		50V	C508	1-164-159-11	CERAMIC	0.1uF	50V
C336	1-162-294-31	CERAMIC	0.001uF	10%	50V	C509	1-164-159-11	CERAMIC	0.1uF	50V
C337	1-164-159-11	CERAMIC	0.1uF		50V	C510	1-164-159-11	CERAMIC	0.1uF	50V
C338	1-164-159-11	CERAMIC	0.1uF		50V	C512	1-164-159-11	CERAMIC	0.1uF	50V
C339	1-124-443-00	ELECT	100uF	20%	10V	C513	1-162-215-31	CERAMIC	47PF	5% 50V
C340	1-124-443-00	ELECT	100uF	20%	10V	C514	1-162-215-31	CERAMIC	47PF	5% 50V
C341	1-164-159-11	CERAMIC	0.1uF		50V	C515	1-124-657-00	ELECT	10uF	20% 50V
C342	1-164-159-11	CERAMIC	0.1uF		50V	C516	1-124-657-00	ELECT	10uF	20% 50V
C343	1-124-443-00	ELECT	100uF	20%	10V	C517	1-162-215-31	CERAMIC	47PF	5% 50V
C344	1-124-443-00	ELECT	100uF	20%	10V	C518	1-162-215-31	CERAMIC	47PF	5% 50V
C345	1-164-159-11	CERAMIC	0.1uF		50V	C519	1-124-657-00	ELECT	10uF	20% 50V
C346	1-164-159-11	CERAMIC	0.1uF		50V	C520	1-124-657-00	ELECT	10uF	20% 50V
C347	1-162-199-31	CERAMIC	10PF	5%	50V	C521	1-162-215-31	CERAMIC	47PF	5% 50V
C348	1-162-199-31	CERAMIC	10PF	5%	50V	C522	1-162-215-31	CERAMIC	47PF	5% 50V
C349	1-126-176-11	ELECT	220uF	20%	10V	C523	1-162-215-31	CERAMIC	47PF	5% 50V
C350	1-164-159-11	CERAMIC	0.1uF		50V	C524	1-162-215-31	CERAMIC	47PF	5% 50V
C351	1-124-477-11	ELECT	47uF	20%	25V	C542	1-164-159-11	CERAMIC	0.1uF	50V
C352	1-124-477-11	ELECT	47uF	20%	25V	C559	1-164-159-11	CERAMIC	0.1uF	50V
C353	1-164-159-11	CERAMIC	0.1uF		50V	C560	1-124-443-00	ELECT	100uF	20% 10V
C354	1-124-479-11	ELECT	330uF	20%	25V	C901	1-128-136-11	ELECT	2200uF	20% 35V
C355	1-164-159-11	CERAMIC	0.1uF		50V	C902	1-128-136-11	ELECT	2200uF	20% 35V
C356	1-164-159-11	CERAMIC	0.1uF		50V	C903	1-128-136-11	ELECT	2200uF	20% 35V
C357	1-124-479-11	ELECT	330uF	20%	25V	C904	1-124-479-11	ELECT	330uF	20% 25V
C358	1-164-159-11	CERAMIC	0.1uF		50V	C905	1-164-159-11	CERAMIC	0.1uF	50V
C359	1-164-159-11	CERAMIC	0.1uF		50V					



## MAIN

Ref. No.	Part No.	Description	Remark
C906	1-124-479-11	ELECT	330uF 20% 25V
C907	1-164-159-11	CERAMIC	0.1uF 50V
C908	1-126-017-11	ELECT	6800uF 20% 16V
C909	1-124-473-11	ELECT	1000uF 20% 10V
C910	1-164-159-11	CERAMIC	0.1uF 50V
C911	1-124-473-11	ELECT	1000uF 20% 10V
C912	1-164-159-11	CERAMIC	0.1uF 50V
C913	1-126-233-11	ELECT	22uF 20% 50V
C914	1-124-903-11	ELECT	1uF 20% 50V
C915	1-124-907-11	ELECT	10uF 20% 50V
C916	1-124-482-11	ELECT	33uF 20% 35V
C917	1-126-233-11	ELECT	22uF 20% 50V
C918	1-126-233-11	ELECT	22uF 20% 50V
C919	1-136-157-00	FILM	0.022uF 5% 50V
C920	1-124-585-11	ELECT	3300uF 20% 10V
C921	1-124-473-11	ELECT	1000uF 20% 10V
< CONNECTOR >			
CN101	1-568-006-11	CONNECTOR, XLR TYPE 3P	
CN102	* 1-564-506-11	PLUG, CONNECTOR 3P	
CN103	1-568-005-11	CONNECTOR, XLR TYPE 3P	
CN201	1-568-006-11	CONNECTOR, XLR TYPE 3P	
CN202	* 1-564-506-11	PLUG, CONNECTOR 3P	
CN203	1-568-005-11	CONNECTOR, XLR TYPE 3P	
CN301	* 1-560-062-00	PIN, CONNECTOR 4P	
CN302	* 1-564-507-11	PLUG, CONNECTOR 4P	
CN303	* 1-564-507-11	PLUG, CONNECTOR 4P	
CN304	* 1-564-507-11	PLUG, CONNECTOR 4P	
CN401	* 1-564-666-11	PIN, CONNECTOR 10P	
CN451	* 1-564-666-11	PIN, CONNECTOR 10P	
CN501	1-580-042-11	CONNECTOR, DIN	
CN504	1-568-200-21	SOCKET, CONNECTOR 9P (REMOTE IN)	
CN505	1-568-200-21	SOCKET, CONNECTOR 9P (REMOTE THRU)	
CN514	* 1-508-980-11	PIN, CONNECTOR	
CN515	* 1-560-532-00	PIN, CONNECTOR 7P	
CN516	* 1-506-509-11	PIN, CONNECTOR 4P	
CN517	* 1-560-532-00	PIN, CONNECTOR 7P	
CN901	* 1-560-064-00	PIN, CONNECTOR 6P	
CN902	* 1-564-505-11	PLUG, CONNECTOR 2P	
< DIODE >			
D101	8-719-911-19	DIODE 1SS119	
D102	8-719-911-19	DIODE 1SS119	
D104	8-719-911-19	DIODE 1SS119	
D105	8-719-911-19	DIODE 1SS119	
D201	8-719-911-19	DIODE 1SS119	
D202	8-719-911-19	DIODE 1SS119	
D204	8-719-911-19	DIODE 1SS119	
D301	8-719-911-19	DIODE 1SS119	
D302	8-719-911-19	DIODE 1SS119	

Ref. No.	Part No.	Description	Remark
D303	8-719-911-19	DIODE 1SS119	
D304	8-719-911-19	DIODE 1SS119	
D305	8-719-911-19	DIODE 1SS119	
D306	8-719-114-29	DIODE RD5. 1JS-B1	
D307	8-719-200-29	DIODE 11DQ04	
D401	8-719-911-19	DIODE 1SS119	
D451	8-719-911-19	DIODE 1SS119	
D501	8-719-911-19	DIODE 1SS119	
D502	8-719-911-19	DIODE 1SS119	
D503	8-719-911-19	DIODE 1SS119	
D504	8-719-911-19	DIODE 1SS119	
D505	8-719-911-19	DIODE 1SS119	
D506	8-719-911-19	DIODE 1SS119	
D507	8-719-911-19	DIODE 1SS119	
D508	8-719-911-19	DIODE 1SS119	
D509	8-719-911-19	DIODE 1SS119	
D510	8-719-911-19	DIODE 1SS119	
D511	8-719-911-19	DIODE 1SS119	
D512	8-719-911-19	DIODE 1SS119	
D513	8-719-911-19	DIODE 1SS119	
D514	8-719-911-19	DIODE 1SS119	
D515	8-719-911-19	DIODE 1SS119	
D516	8-719-911-19	DIODE 1SS119	
D522	8-719-911-19	DIODE 1SS119	
D901	8-719-911-55	DIODE U05G	
D902	8-719-911-55	DIODE U05G	
D903	8-719-911-55	DIODE U05G	
D904	8-719-911-55	DIODE U05G	
D905	8-719-911-55	DIODE U05G	
D906	8-719-911-55	DIODE U05G	
D907	8-719-911-55	DIODE U05G	
D908	8-719-911-55	DIODE U05G	
D909	8-719-200-77	DIODE 10E2N	
D910	8-719-200-77	DIODE 10E2N	
D912	8-719-911-19	DIODE 1SS119	
D913	8-719-911-19	DIODE 1SS119	
D914	8-719-911-19	DIODE 1SS119	
D915	8-719-200-77	DIODE 10E2N	
D916	8-719-200-77	DIODE 10E2N	
D917	8-719-200-77	DIODE 10E2N	
< IC >			
IC101	8-759-982-03	IC NJM5532D-D	
IC102	8-759-982-03	IC NJM5532D-D	
IC104	8-759-982-03	IC NJM5532D-D	
IC105	8-759-982-03	IC NJM5532D-D	
IC106	8-759-982-03	IC NJM5532D-D	

## MAIN

Ref. No.	Part No.	Description	Remark	Ref. No.	Part No.	Description	Remark
IC201	8-759-982-03	IC NJM5532D-D				< PHOTO INTERRUPTER >	
IC202	8-759-982-03	IC NJM5532D-D					
IC204	8-759-982-03	IC NJM5532D-D					
IC205	8-759-982-03	IC NJM5532D-D		PH501	8-719-938-71	DIODE PC900	
IC206	8-759-982-03	IC NJM5532D-D				< TRANSISTOR >	
IC301	8-759-982-03	IC NJM5532D-D		Q301	8-729-900-80	TRANSISTOR DTC114ES	
IC302	8-759-982-31	IC RC78M05FA		Q302	8-729-216-13	TRANSISTOR 2SK161-GR	
IC303	8-759-982-52	IC RC79M05FA		Q303	8-729-905-67	TRANSISTOR 2SD1944-K	
IC304	8-759-502-91	IC AK5328-VP		Q401	8-729-900-89	TRANSISTOR DTC144ES	
IC305	8-752-332-01	IC CXD1144BP		Q402	8-729-900-80	TRANSISTOR DTC114ES	
IC306	8-759-917-18	IC SN74HC004N		Q403	8-729-201-05	TRANSISTOR 2SC2878-B	
IC308	8-752-335-51	IC CXD2552Q-1		Q451	8-729-900-89	TRANSISTOR DTC144ES	
IC311	8-759-982-36	IC RC78M15FA		Q452	8-729-900-80	TRANSISTOR DTC114ES	
IC312	8-759-701-70	IC NJM79M15FA		Q453	8-729-201-05	TRANSISTOR 2SC2878-B	
IC315	8-759-921-19	IC SN74HC161N		Q505	8-729-900-80	TRANSISTOR DTC114ES	
IC316	8-759-921-19	IC SN74HC161N		Q902	8-729-119-78	TRANSISTOR 2SC2785-HFE	
IC317	8-759-916-29	IC SN74HC74N		Q903	8-729-900-80	TRANSISTOR DTC114ES	
IC401	8-759-912-79	IC IR2E02		Q904	8-729-140-98	TRANSISTOR 2SD773-4	
IC402	8-759-945-58	IC RC4558P		Q905	8-729-900-80	TRANSISTOR DTC114ES	
IC451	8-759-912-79	IC IR2E02				< RESISTOR >	
IC501	8-752-331-87	IC CXD1160AP		R101	1-249-469-11	CARBON 100K 5%	1/4W
IC502	8-759-502-90	IC CXD8162P		R102	1-249-469-11	CARBON 100K 5%	1/4W
IC503	8-759-243-04	IC TC514256AP-70		R103	1-249-942-11	CARBON 6.2K 5%	1/4W
IC504	8-759-243-04	IC TC514256AP-70		R104	1-247-725-11	CARBON 10K 5%	1/4W
IC505	8-759-243-04	IC TC514256AP-70		R105	1-247-725-11	CARBON 10K 5%	1/4W
IC506	8-752-331-87	IC CXD1160AP		R106	1-249-942-11	CARBON 6.2K 5%	1/4W
IC507	8-759-916-15	IC SN74HC05N		R107	1-249-469-11	CARBON 100K 5%	1/4W
IC509	8-759-011-90	IC MC34050P		R108	1-249-469-11	CARBON 100K 5%	1/4W
IC901	8-759-929-62	IC LM7812CT		R109	1-249-469-11	CARBON 100K 5%	1/4W
IC902	8-759-982-36	IC RC78M15FA		R110	1-249-462-11	CARBON 22K 5%	1/4W
IC903	8-759-982-31	IC RC78M05FA		R111	1-247-725-11	CARBON 10K 5%	1/4W
IC904	8-759-982-31	IC RC78M05FA		R112	1-249-469-11	CARBON 100K 5%	1/4W
IC905	8-759-802-61	IC LA5666		R113	1-249-469-11	CARBON 100K 5%	1/4W
IC906	8-759-801-79	IC LA5665		R114	1-249-462-11	CARBON 22K 5%	1/4W
		< JACK >		R115	1-215-444-00	METAL 9.1K 1%	1/6W
J101	1-580-041-11	JACK, LARGE (2 GANG) (INPUT)		R116	1-215-437-00	METAL 4.7K 1%	1/6W
J102	1-563-363-11	JACK, LARGE TYPE 2P (OUTPUT)		R117	1-215-444-00	METAL 9.1K 1%	1/6W
		< COIL >		R118	1-215-437-00	METAL 4.7K 1%	1/6W
L301	1-410-324-11	INDUCTOR 4.7uH		R121	1-215-454-00	METAL 24K 1%	1/6W
L302	1-410-324-11	INDUCTOR 4.7uH		R124	1-215-454-00	METAL 24K 1%	1/6W
L303	1-410-324-11	INDUCTOR 4.7uH		R125	1-247-193-00	CARBON 22K 1%	1/4W
L306	1-410-324-11	INDUCTOR 4.7uH		R126	1-249-947-11	CARBON 10K 1%	1/4W
L501	* 1-410-858-11	INDUCTOR 0uH		R127	1-249-941-11	CARBON 5.6K 1%	1/4W
L502	* 1-410-858-11	INDUCTOR 0uH		R128	1-247-715-11	CARBON 1.5K 5%	1/4W
L503	* 1-410-858-11	INDUCTOR 0uH		R129	1-247-721-11	CARBON 4.7K 5%	1/4W
L504	* 1-410-858-11	INDUCTOR 0uH		R130	1-247-725-11	CARBON 10K 5%	1/4W
				R132	1-249-616-11	CARBON 470K 5%	1/4W
				R135	1-249-462-11	CARBON 22K 5%	1/4W

## MAIN

Ref. No.	Part No.	Description	Remark			Ref. No.	Part No.	Description	Remark		
R136	1-249-462-11	CARBON	22K	5%	1/4W	R229	1-247-721-11	CARBON	4.7K	5%	1/4W
R137	1-247-725-11	CARBON	10K	5%	1/4W	R230	1-247-725-11	CARBON	10K	5%	1/4W
R138	1-247-138-00	CARBON	2K	5%	1/4W	R232	1-249-616-11	CARBON	470K	5%	1/4W
R139	1-249-469-11	CARBON	100K	5%	1/4W	R235	1-249-462-11	CARBON	22K	5%	1/4W
R140	1-247-146-00	CARBON	4.3K	5%	1/4W	R236	1-249-462-11	CARBON	22K	5%	1/4W
R141	1-247-723-11	CARBON	6.8K	5%	1/4W	R237	1-247-725-11	CARBON	10K	5%	1/4W
R142	1-249-947-11	CARBON	10K	1%	1/4W	R238	1-247-138-00	CARBON	2K	5%	1/4W
R143	1-249-616-11	CARBON	470K	5%	1/4W	R239	1-249-469-11	CARBON	100K	5%	1/4W
R144	1-249-956-11	CARBON	24K	1%	1/4W	R240	1-247-146-00	CARBON	4.3K	5%	1/4W
R145	1-249-947-11	CARBON	10K	1%	1/4W	R241	1-247-723-11	CARBON	6.8K	5%	1/4W
R146	1-249-956-11	CARBON	24K	1%	1/4W	R242	1-249-947-11	CARBON	10K	1%	1/4W
R147	1-249-903-11	CARBON	150	1%	1/4W	R243	1-249-616-11	CARBON	470K	5%	1/4W
R148	1-249-947-11	CARBON	10K	1%	1/4W	R244	1-249-956-11	CARBON	24K	1%	1/4W
R149	1-249-956-11	CARBON	24K	1%	1/4W	R245	1-249-947-11	CARBON	10K	1%	1/4W
R150	1-249-947-11	CARBON	10K	1%	1/4W	R246	1-249-956-11	CARBON	24K	1%	1/4W
R151	1-249-956-11	CARBON	24K	1%	1/4W	R247	1-249-903-11	CARBON	150	1%	1/4W
R152	1-249-903-11	CARBON	150	1%	1/4W	R248	1-249-947-11	CARBON	10K	1%	1/4W
R153	1-249-947-11	CARBON	10K	1%	1/4W	R249	1-249-956-11	CARBON	24K	1%	1/4W
R154	1-249-947-11	CARBON	10K	1%	1/4W	R250	1-249-947-11	CARBON	10K	1%	1/4W
R155	1-249-469-11	CARBON	100K	5%	1/4W	R251	1-249-956-11	CARBON	24K	1%	1/4W
R156	1-249-469-11	CARBON	100K	5%	1/4W	R252	1-249-903-11	CARBON	150	1%	1/4W
R158	1-247-710-11	CARBON	560	5%	1/4W	R253	1-249-947-11	CARBON	10K	1%	1/4W
R159	1-249-469-11	CARBON	100K	5%	1/4W	R254	1-249-947-11	CARBON	10K	1%	1/4W
R201	1-249-469-11	CARBON	100K	5%	1/4W	R255	1-249-469-11	CARBON	100K	5%	1/4W
R202	1-249-469-11	CARBON	100K	5%	1/4W	R256	1-249-469-11	CARBON	100K	5%	1/4W
R203	1-249-942-11	CARBON	6.2K	5%	1/4W	R258	1-247-710-11	CARBON	560	5%	1/4W
R204	1-247-725-11	CARBON	10K	5%	1/4W	R259	1-249-469-11	CARBON	100K	5%	1/4W
R205	1-247-725-11	CARBON	10K	5%	1/4W	R301	1-259-396-11	CARBON	47	5%	1/6W
R206	1-249-942-11	CARBON	6.2K	5%	1/4W	R302	1-259-396-11	CARBON	47	5%	1/6W
R207	1-249-469-11	CARBON	100K	5%	1/4W	R303	1-259-404-11	CARBON	100	5%	1/6W
R208	1-249-469-11	CARBON	100K	5%	1/4W	R307	1-259-380-11	CARBON	10	5%	1/6W
R209	1-249-469-11	CARBON	100K	5%	1/4W	R308	1-259-452-11	CARBON	10K	5%	1/6W
R210	1-249-462-11	CARBON	22K	5%	1/4W	R309	1-259-428-11	CARBON	1K	5%	1/6W
R211	1-247-725-11	CARBON	10K	5%	1/4W	R310	1-259-404-11	CARBON	100	5%	1/6W
R212	1-249-469-11	CARBON	100K	5%	1/4W	R311	1-259-404-11	CARBON	100	5%	1/6W
R213	1-249-469-11	CARBON	100K	5%	1/4W	R312	1-259-404-11	CARBON	100	5%	1/6W
R214	1-249-462-11	CARBON	22K	5%	1/4W	R313	1-259-404-11	CARBON	100	5%	1/6W
R215	1-215-444-00	METAL	9.1K	1%	1/6W	R314	1-259-404-11	CARBON	100	5%	1/6W
R216	1-215-437-00	METAL	4.7K	1%	1/6W	R315	1-259-404-11	CARBON	100	5%	1/6W
R217	1-215-444-00	METAL	9.1K	1%	1/6W	R316	1-259-500-11	CARBON	1M	5%	1/6W
R218	1-215-437-00	METAL	4.7K	1%	1/6W	R317	1-259-404-11	CARBON	100	5%	1/6W
R221	1-215-454-00	METAL	24K	1%	1/6W	R319	1-259-428-11	CARBON	1K	5%	1/6W
R224	1-215-454-00	METAL	24K	1%	1/6W	R320	1-259-445-11	CARBON	5.1K	5%	1/6W
R225	1-247-193-00	CARBON	22K	1%	1/4W	R321	1-259-396-11	CARBON	47	5%	1/6W
R226	1-249-947-11	CARBON	10K	1%	1/4W	R322	1-259-396-11	CARBON	47	5%	1/6W
R227	1-249-941-11	CARBON	5.6K	1%	1/4W	R323	1-259-428-11	CARBON	1K	5%	1/6W
R228	1-247-715-11	CARBON	1.5K	5%	1/4W	R324	1-259-404-11	CARBON	100	5%	1/6W
						R325	1-259-404-11	CARBON	100	5%	1/6W

**MAIN KEY**

Ref. No.	Part No.	Description	Remark		
R326	1-259-404-11	CARBON	100	5%	1/6W
R402	1-259-424-11	CARBON	680	5%	1/6W
R403	1-259-452-11	CARBON	10K	5%	1/6W
R404	1-259-464-11	CARBON	33K	5%	1/6W
R405	1-259-455-11	CARBON	13K	5%	1/6W
R406	1-259-471-11	CARBON	62K	5%	1/6W
R407	1-259-440-11	CARBON	3.3K	5%	1/6W
R409	1-259-452-11	CARBON	10K	5%	1/6W
R410	1-259-424-11	CARBON	680	5%	1/6W
R411	1-215-430-00	METAL	2.4K	1%	1/6W
R412	1-215-434-00	METAL	3.6K	1%	1/6W
R413	1-259-452-11	CARBON	10K	5%	1/6W
R414	1-259-452-11	CARBON	10K	5%	1/6W
R415	1-259-452-11	CARBON	10K	5%	1/6W
R416	1-259-420-11	CARBON	470	5%	1/6W
R452	1-259-424-11	CARBON	680	5%	1/6W
R453	1-259-452-11	CARBON	10K	5%	1/6W
R454	1-259-464-11	CARBON	33K	5%	1/6W
R455	1-259-455-11	CARBON	13K	5%	1/6W
R456	1-259-471-11	CARBON	62K	5%	1/6W
R457	1-259-440-11	CARBON	3.3K	5%	1/6W
R459	1-259-452-11	CARBON	10K	5%	1/6W
R460	1-259-424-11	CARBON	680	5%	1/6W
R466	1-259-420-11	CARBON	470	5%	1/6W
R501	1-259-500-11	CARBON	1M	5%	1/6W
R502	1-259-412-11	CARBON	220	5%	1/6W
R503	1-259-412-11	CARBON	220	5%	1/6W
R504	1-259-412-11	CARBON	220	5%	1/6W
R505	1-259-436-11	CARBON	2.2K	5%	1/6W
R506	1-259-412-11	CARBON	220	5%	1/6W
R507	1-259-380-11	CARBON	10	5%	1/6W
R508	1-259-380-11	CARBON	10	5%	1/6W
R509	1-249-782-11	CARBON	150	5%	1/6W
R510	1-259-428-11	CARBON	1K	5%	1/6W
R511	1-259-428-11	CARBON	1K	5%	1/6W
R512	1-259-468-11	CARBON	47K	5%	1/6W
R513	1-259-468-11	CARBON	47K	5%	1/6W
R514	1-249-782-11	CARBON	150	5%	1/6W
R515	1-259-428-11	CARBON	1K	5%	1/6W
R516	1-259-428-11	CARBON	1K	5%	1/6W
R517	1-259-468-11	CARBON	47K	5%	1/6W
R518	1-259-468-11	CARBON	47K	5%	1/6W
R519	1-259-380-11	CARBON	10	5%	1/6W
R520	1-259-380-11	CARBON	10	5%	1/6W
R526	1-259-404-11	CARBON	100	5%	1/6W
R527	1-259-436-11	CARBON	2.2K	5%	1/6W
R529	1-259-452-11	CARBON	10K	5%	1/6W

Ref. No.	Part No.	Description	Remark		
R534	1-259-452-11	CARBON	10K	5%	1/6W
R539	1-259-412-11	CARBON	220	5%	1/6W
R540	1-259-412-11	CARBON	220	5%	1/6W
R901	1-259-452-11	CARBON	10K	5%	1/6W
R902	1-259-460-11	CARBON	22K	5%	1/6W
R903	1-259-415-11	CARBON	300	5%	1/6W
R904	1-249-782-11	CARBON	150	5%	1/6W
R905	1-259-482-11	CARBON	180K	5%	1/6W
R906	1-259-452-11	CARBON	10K	5%	1/6W
R907	1-259-436-11	CARBON	2.2K	5%	1/6W
R908	1-259-468-11	CARBON	47K	5%	1/6W
R909	1-259-468-11	CARBON	47K	5%	1/6W
R910	1-259-428-11	CARBON	1K	5%	1/6W
R911	1-259-428-11	CARBON	1K	5%	1/6W
R912	△ 1-216-433-00	METAL OXIDE	1.2K	5%	1W F
R917	△ 1-216-355-11	METAL OXIDE	3.3	5%	1W F
< VARIABLE RESISTOR >					
RV401	1-238-016-11	RES. ADJ. CARBON 10K (LED LEVEL L)			
RV451	1-238-016-11	RES. ADJ. CARBON 10K (LED LEVEL R)			
< RELAY >					
RY101	1-515-726-11	RELAY			
RY102	1-515-726-11	RELAY			
RY103	1-515-726-11	RELAY			
RY104	1-515-726-11	RELAY			
RY201	1-515-726-11	RELAY			
RY202	1-515-726-11	RELAY			
RY203	1-515-726-11	RELAY			
< CRYSTAL >					
X301	1-579-248-11	FILTER, CRYSTAL (15.36MHz)			
X302	1-579-247-11	VIBRATOR, CRYSTAL (40.96MHz)			
X501	1-579-246-11	VIBRATOR, CRYSTAL (26.0MHz)			
*****					
* 1-635-808-11 KEY BOARD					
*****					
< SWITCH >					
S501	1-572-198-11	SWITCH, KEY BOARD (LOAD)			
S502	1-572-198-11	SWITCH, KEY BOARD (EDIT)			
S503	1-572-198-11	SWITCH, KEY BOARD (BYPASS)			
S504	1-572-198-11	SWITCH, KEY BOARD (HELP)			
S505	1-572-198-11	SWITCH, KEY BOARD (SAVE)			
S506	1-572-198-11	SWITCH, KEY BOARD (ENTER)			

<p><b>Note:</b> The components identified by mark <b>△</b> or dotted line with mark <b>△</b> are critical for safety. Replace only with part number specified.</p>	<p><b>Note:</b> Les composants identifiés par une marque <b>△</b> sont critiques pour la sécurité. Ne les remplacer que par une pièce portant le numéro spécifié.</p>
--	---

**VOL** **MET** **AC** **INVOL** **RE**

Ref. No.	Part No.	Description	Remark
	* 1-635-809-11	VOL BOARD ***** < VARIABLE RESISTOR >	
RV302	1-237-306-11	RES. VAR. CARBON 10K/10K (DRY)	
RV303	1-237-306-11	RES. VAR. CARBON 10K/10K (EFFECT)	
*****			
	* 1-635-810-11	MET BOARD ***** < DIODE >	
D402	8-759-502-93	LED LD-010DW	
D452	8-759-502-93	LED LD-010DW	
*****			
	* 1-635-811-11	AC BOARD ***** 4-870-539-00 PLATE, GROUND < CAPACITOR >	
C1	△ 1-161-744-00	CERAMIC 0.01uF 400V	
C2	△ 1-161-742-00	CERAMIC 0.0022uF 20% 400V	
C3	△ 1-161-742-00	CERAMIC 0.0022uF 20% 400V	
C4	△ 1-161-742-00	CERAMIC 0.0022uF 20% 400V	
C5	△ 1-161-742-00	CERAMIC 0.0022uF 20% 400V	
*****			
		< CONNECTOR >	
CN1	* 1-580-629-11	PIN, CONNECTOR 2P	
CN2	* 1-564-687-11	PIN, CONNECTOR 3P	
*****			
		< LINE FILTER >	
LF1	△ 1-421-915-11	COIL, LINE FILTER	
*****			
		< SWITCH >	
S1	△ 1-572-418-11	SWITCH, PUSH (AC POWER) (US, Canadian)	
S1	△ 1-572-530-11	SWITCH, PUSH (AC POWER) (1KEY) (AEP, UK, E)	
S2	1-570-173-11	SWITCH, VOLTAGE CHANGE	
*****			
	* 1-635-812-11	INVOL BOARD ***** < VARIABLE RESISTOR >	
RV301	1-241-170-11	RES. VAR. CARBON 20K/20K (INPUT)	

Ref. No.	Part No.	Description	Remark
	* 1-635-814-11	RE BOARD ***** < DIODE >	
D591	1-466-386-11	DIODE ENCODER, ROTARY	
*****			
		MISCELLANEOUS *****	
56	1-572-490-21	SWITCH, PUSH (AC POWER)	
CNJ1	△ 1-580-375-21	INLET 3P (AC IN)	
CNP507	* 1-575-940-11	LEAD (WITH CONNECTOR)	
F901	△ 1-532-215-00	FUSE, TIME-LAG (AEP, UK, E)	
F901	△ 1-532-739-11	FUSE, GLASS TUBE (US, Canadian)	
F902	△ 1-532-215-00	FUSE, TIME-LAG (AEP, UK, E)	
F902	△ 1-532-739-11	FUSE, GLASS TUBE (US, Canadian)	
F903	△ 1-532-215-00	FUSE, TIME-LAG (AEP, UK, E)	
F903	△ 1-532-739-11	FUSE, GLASS TUBE (US, Canadian)	
F904	△ 1-532-215-00	FUSE, TIME-LAG (AEP, UK, E)	
F904	△ 1-532-739-11	FUSE, GLASS TUBE (US, Canadian)	
LCD1	1-809-076-11	DISPLAY PANEL, LIQUID CRYSTAL	
T901	△ 1-450-176-11	TRANSFORMER, POWER (US, Canadian)	
T901	△ 1-450-690-11	TRANSFORMER, POWER (AEP, UK, E)	
*****			
		ACCESSORIES & PACKING MATERIALS *****	
	△ 1-557-377-11	CORD, POWER (US, Canadian)	
	△ 1-590-910-11	CORD SET, POWER (AEP, UK, E)	
	3-701-947-10	LABEL (T800MA), FUSE (AEP, UK, E)	
	* 3-704-343-01	SHEET (STANDARD), PROTECTION	
	3-752-908-11	MANUAL, INSTRUCTION (GERMAN, SPANISH) (AEP, UK, E)	
	3-752-908-21	MANUAL, INSTRUCTION (ENGLISH, FRENCH)	
	* 4-941-101-01	CUSHION (L)	
	* 4-941-102-01	CUSHION (R)	
	* 4-947-725-11	INDIVIDUAL CARTON	

**Note:**  
The components identified by mark △ or dotted line with mark △ are critical for safety. Replace only with part number specified.

**Note:**  
Les composants identifiés par une marque △ sont critiques pour la sécurité. Ne les remplacer que par une pièce portant le numéro spécifié.

Ref. No.	Part No.	Description	Remark
----------	----------	-------------	--------

**HARDWARE LIST**  
\*\*\*\*\*

#1	7-682-547-09	SCREW +BV 3X6, S TIGHT	
#2	7-682-247-09	SCREW +K 3X6	
#3	7-685-870-01	SCREW +BVTT 3X5 (S)	
#4	7-685-645-79	SCREW +BTP 3X6 TYPE2 N-S	
#5	7-685-105-19	TOTSU PTPWH 2X8, TYPE2, SLIT	
#6	7-685-646-79	SCREW +BTP 3X8 TYPE2 N-S	
#7	7-621-775-20	SCREW +P 2.6X5	
#8	7-682-548-09	SCREW +BVTT 3X8 (S)	
#9	7-621-771-06	SCREW, LOCK	
#10	7-682-661-09	SCREW +PS 4X8	
#11	7-682-548-04	SCREW, TIGHT, S	
#12	7-685-133-19	SCREW +P 2.6X6 TYPE2 NON-SLIT (AEP, UK, E)	

# DPS-R7

100

## SONY SERVICE MANUAL

4889  
US Model  
Canadian Model  
AEP Model  
UK Model  
E Model

### SUPPLEMENT-1

File this supplement with the service manual.

Data Format of MIDI

## CONTENTS

Introduction	4
Hardware of MIDI	4
Data Format of MIDI	4
MIDI Implementation Chart	6
Channel voice messages	6
Program change	6
Control change	6
Note ON	6
Channel key pressure	6
Channel mode messages	6
Mode message	6
System exclusive messages	7
Identity Request	7
Identity Reply	7
Format of SONY exclusive messages	7
Commands	8
ALL DATA DUMP REQUEST	8
ALL USER MEMORY DUMP REQUEST	8
SYSTEM DUMP REQUEST	8
MIDI DUMP REQUEST	8
USER MEMORY DUMP REQUEST	8
ALL USER MEMORY DUMP	8
SYSTEM DUMP	9
MIDI DUMP	9
USER MEMORY DUMP	9
Start address transfer	9
Data transfer	10
System check	10
Data Composition of User Memory and Data Length of Each Block	12
ALG	13
LCL.MIDI	14
INPUT	15
PRE-EF	15
through :OFF	15
stereo EQ :SEQ	15
phase shifter :PHS	17
flanger :FLG	18
stereo exciter + EQ :SXE	18
mono exciter + EQ :MXE	19
gate :GTE	20
OUTPUT	20
POST-EF	21
through :OFF	21
stereo EQ :SEQ	21
phase shifter :PHS	21
flanger :FLG	21
stereo exciter + EQ :SXE	21
mono exciter + EQ :MXE	21
gate :GTE	22
autopan :APN	23
REVC/REVS Block	24
through :OFF	24
hall reverberation :HLR	24
room reverberation :RMR	26
plate reverberation :PLR	28
gate reverberation :GTR	30
early reflection :ERF	32
REVC/REV1 Block	36
plate reverberation :PLR	36
gate reverberation :GTR	37
early reflection :ERF	38
delay 1 :DL1	40
delay 2 :DL2	42
REVC/REV2 Block	44
plate reverberation :PLR	44
gate reverberation :GTR	45
early reflection :ERF	46
delay 1 :DL1	48
delay 2 :DL2	50
DATE	52
NAME	52
Data Composition and Data Length of System	54
SYSTEM	54
Data Composition and Data Length of System MIDI	54
SYS.MIDI	54
Examples of Data	55



## Introduction

MIDI is the acronym for Musical Instrument Digital Interface, worldwide common specifications of data communications systems between electronic instruments, with which the operator can control other electronic instruments using a keyboard or those which can automatically play music using a sequencer or a computer. As long as an instrument complies with the MIDI specifications, it can transmit to another instrument of a different manufacturer in a different type.

## Hardware of MIDI

### Circuit

The MIDI interface transmits information in an asynchronous serial transmission system at a transmission rate of 31.25 Kbit/sec ( $\pm 1\%$ ), in a format of a start bit, 8 data bits and a stop bit without parity. The interface transmits and receives data at a forwarding rate more than 3 times as high as 9600 bit/sec normally in effect with an ordinary RS-232C interface used for personal computers, etc.

The circuit of the interface employs an optical isolator to prevent creation of a ground loop and errors in data, caused by the loop, thus electrically isolating the transmission side from the receiving side.

### Connectors

The following 3 types of MIDI terminals carry MIDI data for transmission and receiving:

MIDI IN: Receives data from other MIDI apparatus.

MIDI OUT: Transmits data to other MIDI apparatus.

MIDI THRU: Transmits data received by the MIDI IN, without modifications.

## Data Format of MIDI

Interfacing of MIDI data is activated by the "Messages" composed of several bytes. Except for the real-time and exclusive messages, each "Message" consists of a "status byte" and a "data byte" or two "data bytes." At that time, the number of "data bytes" is determined by the "status byte."

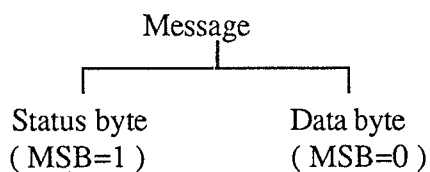

The "Messages" are classified into "channel message" for transmitting information on playing and "system message" for transmitting information necessary for the entire system.

With a "channel message," 16 channels can be assigned using 4 LSD bits of the "status byte," from which only data required by the receiving side can be extracted, as if a receiving channel is selected with a TV set.

\* With the omni mode turned ON, information in any MIDI channel can be received no matter which MIDI channel is set.

The "channel messages" are classified into "voice message" for controlling information on playing or setting and "mode message" for determining how an apparatus in the receiving side controls the voice message.

The "system messages" are classified into "common message" effective in the entire system, "real-time message" effective in the entire system and transmissible even to a byte in another message" and "exclusive message" capable of transmitting any number of bytes for data following a status byte. With the DPS series, data in the user memory can be transmitted or received using the exclusive message.

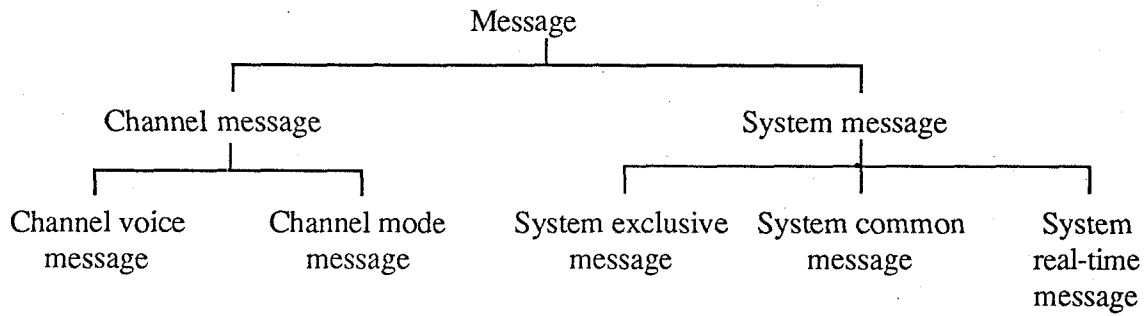

# MIDI Implementation Chart

## Channel voice messages

### ● Program change (receiving)

When the captioned command in the same channel (or all channels with the omni turned ON):

When DPS-R7 is in LOAD state - The memory preset by the program change no. or memory no. of the SYS.MIDI is accessed.

When DPS-R7 is in the state of selecting program change no. of the SYS.MIDI - Received program number is selected.

command	1 1 0 0 n n n n (C n) n n n n : channel number (0-16)
data	0 p p p p p p p p p p p p p p p p : program number (0-127)

### ● Control change (receiving)

When the command in the same channel (or all channels with the omni turned ON) is received, parameters preset by LCL.MIDI are controlled.

command	1 0 1 1 n n n n (B n) n n n n : channel number (0-16)
data	0 c c c c c c c c 0 v v v v v v v v c c c c c c c c : control number (0-127) v v v v v v v v : control value (0-127)

### ● Note ON (receiving)

When the command in the same channel (or all channels with the omni turned ON) is received, parameters preset by LCL.MIDI are controlled.

command	1 0 0 1 n n n n (9 n) n n n n : channel number (0-16)
data	0 k k k k k k k k 0 v v v v v v v v k k k k k k k k : note number (0-127) v v v v v v v v : note on velocity (1-127)

### ● Channel key pressure (channel after-touch) (receiving)

When the command in the same channel (or all channels with the omni turned ON) is received, parameters preset by LCL.MIDI are controlled.

command	1 1 0 1 n n n n (D n) n n n n : channel number (0-16)
data	0 v v v v v v v v v v v v v v v v : pressure value (0-127)

## Channel mode messages

### ● Mode message (receiving)

When the command in the same channel is received, the mode is changed to omni-ON (or OFF).

command	1 0 1 1 n n n n (B n) n n n n : channel number (0-16)
data	0 c c c c c c c c 0 v v v v v v v v c c c c c c c c = 124 omni mode off = 125 omni mode on v v v v v v v v = 0

## System exclusive messages

### ●Identity Request (receiving)

When the message is received, Identity Reply is transmitted.

byte	description
11110000 (F0)	System exclusive status
01111110 (7E)	Non real time
0000nnnn (0n)	MIDI channel
00000110 (06)	General information
00000001 (01)	Identity Request
11110111 (F7)	End of exclusive

### ●Identity Reply (transmission)

The message is issued only when Identity Request is received.

byte	description
11110000 (F0)	System exclusive status
01111110 (7E)	Non real time
0000nnnn (0n)	MIDI channel
00000110 (06)	General Information
00000010 (02)	Identity Reply
01001100 (4C)	SONY ID
00000001 (01)	Device family code
00000000 (00)	
00000010 (02)	Device family number code
00000000 (00)	
sssss ssss (ss)	software version
sssss ssss (ss)	
sssss ssss (ss)	
sssss ssss (ss)	
11110111 (F7)	End of exclusive

software version - 4 byte ASCII code

Example: Ver. 1.20 = 31 2E 32 30

## Format of SONY exclusive messages

byte	description
11110000 (F0)	System exclusive status
01001100 (4C)	SONY ID
0000nnnn (0n)	Global channel
00010010 (12)	DPS-R7 ID
0ccccccc	Command
0ddddddd	Data
⋮	
⋮	
0ddddddd	
11110111 (F7)	End of exclusive

\* Global channel = MIDI channel

\* Data length differs depending on each command.

## Commands

### ● ALL DATA DUMP REQUEST (receiving)

When the command is received, all data (all data in the user memory, system information and system MIDI information) is transmitted.

command	0 0 0 1 0 0 0 0 (1 0)
data	None

### ● ALL USER MEMORY DUMP REQUEST (receiving)

When the command is received, all data in the user memory is transmitted.

command	0 0 0 1 0 0 0 1 (1 1)
data	None

### ● SYSTEM DUMP REQUEST (receiving)

When the command is received, system information is transmitted.

command	0 0 0 1 0 0 1 0 (1 2)
data	None

### ● MIDI DUMP REQUEST (receiving)

When the command is received, system MIDI information is transmitted.

command	0 0 0 1 0 0 1 1 (1 3)
data	None

### ● USER MEMORY DUMP REQUEST (receiving)

When the command is received, data in an assigned user memory or preset memory is transmitted.

command	0 0 0 1 0 1 n n (1 4 or 1 5 or 1 6) bit 8 7
data	0 n n n n n n n bit 6 5 4 3 2 1 0 n n n n n n n n : memory number (0-355) bit 8 7 6 5 4 3 2 1 0 0-255 : user no-1 256-355 : preset no+255

### ● ALL USER MEMORY DUMP (transmission and receiving)

All data in the user memory is transmitted or received.

command	0 0 0 1 1 0 0 1 (1 9)
data	0 d d d d d d d . . . . d d d d d d d : data (see note 1, 2)

●SYSTEM DUMP (transmission and receiving)

System information is transmitted or received.

command	0 0 0 1 1 0 1 0 (1A)
data	0 d d d d d d d d . . . . . d d d d d d d d : data (see note 1, 3)

●MIDI DUMP (transmission and receiving)

MIDI information is transmitted or received.

command	0 0 0 1 1 0 1 1 (1B)
data	0 d d d d d d d d . . . . . d d d d d d d d : data (see note 1, 4)

●USER MEMORY DUMP (transmission and receiving)

Data in an assigned user memory or preset memory is transmitted.

Or, data in an assigned user memory is received.

command	0 0 0 1 1 1 n n (1C or 1D or 1E) bit 8 7
data	0 n n n n n n n bit 6 5 4 3 2 1 0 0 d d d d d d d . . . . .  n n n n n n n n : memory number (transmission & receiving : 0 - 2 5 5) bit 8 7 6 5 4 3 2 1 0 (transmission : 0 - 3 5 5) Transmission & receiving 0 - 2 5 5 : user no - 1 Transmission only 2 5 6 - 3 5 5 : preset no + 2 5 5  d d d d d d d d : data (see note 1)

●Start address transfer (receiving)

Although a subroutine can be accessed directly to an assigned address using the captioned command, preferably do not use the command because the absolute address is not disclosed.

Even if data in the user memory, etc. is destroyed by using the command, SONY is not liable for any losses.

command	0 0 1 0 0 0 0 0 (20)
data	0 a a a a a a a bit 6 5 4 3 2 1 0 0 a a a a a a a bit DCBA987 0 0 0 a a a a a bit 12 11 10 FE  a a a a a a a a a a a a a a a a a a : Start address (0h - 7FFFFh) bit 12 11 10 FE DCBA9876543210



▼note 4 - MIDI DUMP FORMAT

dd0 - dd257 : MIDI DATA

▼note 5 - USER MEMORY DUMP FORMAT

dd0 - dd544 (max) : USER MEMORY DATA

▼note 6 - ss : System check subcommand

ss < 40h : 1 byte type

ss ≥ 40h : Plural byte type (The following data is processed in the data type of note 1. Data length is determined by the subcommand.)

· 1 byte type

00h - 1Fh Checked result

· 5 byte type data (see note 1)

7Fh... SOFT Ver.

( SOFT Ver. - 4 byte ASCII code

Example: Ver. 1.20 = 31 2E 32 30 )

▼note 7 - ss : System request format

dd < 40h : 1 byte type

ss ≥ 40h : Plural byte type (The following data is processed in a data type of note 1. Data length is determined by the subcommand.)

· 1 byte type data

20h - 2Fh Check command

· 7 byte type data (see note 1)

70h... DATE SET

( DATE DATA - 6 byte data

ex. '92 Jun 21 12:34:56 = 5C 06 15 0C 22 38 )



## Data Composition of User Memory and Data Length of Each Block

When reverse block is a stereo-in, stereo-out type:

block name	byte
ALG	4
LCL.MIDI	12
INPUT	16
PRE-EF	0 - 22
OUTPUT	16
POST-EF	0 - 22
REVC/REVS	0 - 402
DATE	2
USER MEMORY NAME	47
CHECK SUM	1

When reverse block is monaural-in, stereo-out type × 2:

block name	byte
ALG	4
LCL.MIDI	12
INPUT	16
PRE-EF	0 - 22
OUTPUT	16
POST-EF	0 - 22
REVC/REV1	32 - 196
REVC/REV2	32 - 196
DATE	2
USER MEMORY NAME	47
CHECK SUM	1

- \* With ALL USER MEMORY DUMP in use, adjust the leading end address of each user memory to become an even number by entering an empty byte after CHECK SUM.
- \* CHECK SUM is a MSB after adding data from ALG to USER MEMORY NAME in byte units.

Each block address and data composition are described in the following.

Each word data in the type column is stored as follows in the above:

Example) It is stored like

H	L
└───┘	└───┘
Address 0	1

Data address represents the offset value from the leading end of the block.

## ALG

name	ch	type	data address	comment
REV2 algorithm		byte	0	
REV1/REVS algorithm		"/	1	
PRE-EF algorithm		"/	2	
POST-EF algorithm		"/	3	

name	data composition
REV2 algorithm	bit7 : memory protect : 1 = on : 0 = off bit6-0 : REV2 algorithm : 9 - 13 9: plate reverberation :PLR 10: gate reverberation :GTR 11: early reflection :ERF 12: delay 1 :DL1 13: delay 2 :DL2
REVS/REV1 algorithm	bit7-0 : REVS/REV1 algorithm : 0 - 5 or 9 - 13 0: through :OFF 1: hall reverberation :HLR 2: room reverberation :RMR 3: plate reverberation :PLR 4: gate reverberation :GTR 5: early reflection :ERF 9: plate reverberation :PLR 10: gate reverberation :GTR 11: early reflection :ERF 12: delay 1 :DL1 13: delay 2 :DL2
PRE-EF algorithm	bit7-0 : PRE-EF algorithm : 0 - 6 0: through :OFF 1: stereo equalizer :SEQ 2: phase shifter :PHS 3: flanger :FLG 4: stereo exciter + EQ :SXE 5: mono exciter + EQ :MXE 6: gate :GTE
POST-EF algorithm	bit7-0 : POST-EF algorithm : 0 - 7 0: through :OFF 1: stereo equalizer :SEQ 2: phase shifter :PHS 3: flanger :FLG 4: stereo exciter + EQ :SXE 5: mono exciter + EQ :MXE 6: gate :GTE 7: autopan :APN

In the REVS/REV1 and REV2 algorithms above, bits 0 - 5 are stereo-in, stereo-out types (ST-ST) while bits 9 - 13 are mono-in, stereo-out types (MN-ST). When a ST-ST algorithm is set in the REVS/REV1, set REV2 to 00h. When a MN-ST algorithm is set in the REVS/REV1, set the MN-ST algorithm also to the REV2.

In other words, it is possible to select either a ST-ST set type or two MN-ST set types.

LCL.MIDI

name	ch	type	data address	comment
ctl no 1		byte	0	
ctl no 2		∕	1	
ctl no 3		∕	2	
ctl no 4		∕	3	
blk/prm no 1		word	4	
blk/prm no 2		∕	5 - 6	
blk/prm no 3		∕	7 - 8	
blk/prm no 4		∕	9 - A	

name	data composition	
ctl no 1 - 4	0 - 125 , 1 step	0 - 120 : control no. 121 : Not in use 122 : note on velocity 123 : channel pressure 124 : note on number 125 : off
blk/prm no 1 - 4	bit15 - 12 : block no	0 : REVC 1 : REVS 2 : REV1 3 : REV2 4 : PRE-EF 5 : POST-EF 6 : INPUT 7 : OUTPUT
	bit11 - 0 : parameter no. - 1	

Note 1) Parameter no. corresponds to "x" of [x/xx] in editing with the LCD display of the main DPS-R7 unit. ([x/xx] indicates that the number of total parameters in the block is xx and that the parameter currently displayed is no. x.)

Note 2) Do not assign a block or parameter which is non-existent in the user memory.

Example) "exciter level sync" of PRE-EF:SXE is to be allocated:

First, block no. becomes 4 (0100) because it is PRE. Next, parameter no. indicated on the edit screen of R7 is [2/17] (it means that the number of total parameters in SXE is 17 while exciter level sync is no. 2), so 2-1=1 holds. Consequently, blk/prm no. becomes 01000000 00000001.

## INPUT

name	ch	type	data address	comment
level	ch1	word	0 - 1	MSB = phase
〃	ch2	〃	2 - 3	〃
panpot	ch1	〃	4 - 5	
〃	ch2	〃	6 - 7	
panpot limit min	ch1	〃	8 - 9	
〃	ch2	〃	A - B	
panpot limit max	ch1	〃	C - D	
〃	ch2	〃	E - F	

name	data composition	
level	0 - 1024 , 1 step	0 - 100% , 0.0977% step
phase	bit15	0 : normal , 1 : inverse
panpot	0 - 1024 , 1 step	0 - 100% , 0.0977% step
panpot limit min	〃	〃
panpot limit max	〃	〃

Note) panpot limit min  $\leq$  panpot  $\leq$  panpot limit max

## PRE-EF

through :OFF

No data

## stereo EQ :SEQ

name	ch	type	data address	comment
stereo EQ on/off		byte	0	
empty		〃	1	
bass level	ch1	〃	2	
〃	ch2	〃	3	
bass freq	ch1	〃	4	
〃	ch2	〃	5	
treble level	ch1	〃	6	
〃	ch2	〃	7	
treble freq	ch1	〃	8	
〃	ch2	〃	9	
peq level	ch1	〃	A	
〃	ch2	〃	B	
peq freq	ch1	〃	C	
〃	ch2	〃	D	
peq q	ch1	〃	E	
〃	ch2	〃	F	

name	data composition	
stereo EQ on/off	0 - 1 , 1 step	0 : off , 1 : on
bass level	0 - 240 , 1 step	-12dB - 12dB , 0.1dB step
treble level	∕	∕
peq level	∕	∕
bass freq.	4 - 56 , 1 step	16Hz - 6.3kHz , 1/6oct step
treble freq.	32 - 66 , 1 step	400Hz - 20.0kHz , ∕
peq freq.	16 - 66 , 1 step	63Hz - 20.0kHz , ∕
peq q	0 - 7 , 1 step	0 : 0.267 ( 4oct ) 1 : 0.667 ( 2oct ) 2 : 1.414 ( 1oct ) 3 : 2.145 ( 2/3oct ) 4 : 4.319 ( 1/3oct ) 5 : 8.651 ( 1/6oct ) 6 : 17.31 ( 1/12oct ) 7 : 34.62 ( 1/24oct )

\* Frequency data of EQ represents the following frequencies.

4	16.0 Hz	20	100 Hz	36	630 Hz	52	4.00 kHz
5	18.0 Hz	21	112 Hz	37	710 Hz	53	4.50 kHz
6	20.0 Hz	22	125 Hz	38	800 Hz	54	5.00 kHz
7	22.5 Hz	23	140 Hz	39	900 Hz	55	5.60 kHz
8	25.0 Hz	24	160 Hz	40	1.00 kHz	56	6.30 kHz
9	28.0 Hz	25	180 Hz	41	1.12 kHz	57	7.10 kHz
10	31.5 Hz	26	200 Hz	42	1.25 kHz	58	8.00 kHz
11	35.5 Hz	27	225 Hz	43	1.40 kHz	59	9.00 kHz
12	40.0 Hz	28	250 Hz	44	1.60 kHz	60	10.0 kHz
13	45.0 Hz	29	280 Hz	45	1.80 kHz	61	11.2 kHz
14	50.0 Hz	30	315 Hz	46	2.00 kHz	62	12.5 kHz
15	56.0 Hz	31	355 Hz	47	2.25 kHz	63	14.0 kHz
16	63.0 Hz	32	400 Hz	48	2.50 kHz	64	16.0 kHz
17	71.0 Hz	33	450 Hz	49	2.80 kHz	65	18.0 kHz
18	80.0 Hz	34	500 Hz	50	3.15 kHz	66	20.0 kHz
19	90.0 Hz	35	560 Hz	51	3.55 kHz		

phase shifter :PHS

name	ch	type	data address	comment
phase shifter on/off		byte	0	
empty		/"	1	
LFO freq		word	2 - 3	
resonance level	ch1	/"	4 - 5	MSB = phase
	ch2	/"	6 - 7	/"
depth		/"	8 - 9	
depth:limit max		/"	A - B	
direct level	ch1	/"	C - D	MSB = phase
	ch2	/"	E - F	/"
effect level	ch1	/"	10 - 11	/"
	ch2	/"	12 - 13	/"

name	data composition	
phase shifter on/off	0 - 1, 1 step	0 : off, 1 : on
LFO freq	10 - 290, 1 step	10 - 100 : 0.10Hz - 1.00Hz, 0.01Hz step 101 - 290 : 1.00Hz - 20.0Hz, 0.1Hz step
resonance level	0 - 1024, 1 step	0 - 100%, 0.0977% step
resonance phase	bit15	0 : normal, 1 : inverse
depth	0 - 1024, 1 step	0 - 100%, 0.0977% step
depth:limit max	/"	/"
direct level	/"	/"
effect level	/"	/"
direct phase	bit15	0 : normal, 1 : inverse
effect phase	/"	/"

Note) depth  $\leq$  depth:limit max

flanger :FLG

name	ch	type	data address	comment
flanger on/off		byte	0	
empty		"/	1	
LFO freq		word	2 - 3	
feedback level		"/	4 - 5	MSB = phase
depth		"/	6 - 7	
depth:limit max		"/	8 - 9	
input level	ch1	"/	1A - 1B	MSB = phase
	ch2	"/	1C - 1D	"/
direct level	ch1	"/	1E - 1F	"/
	ch2	"/	20 - 21	"/
effect level	ch1	"/	22 - 23	"/
	ch2	"/	24 - 25	"/

name	data composition	
flanger on/off	0 - 1, 1 step	0 : off, 1 : on
LFO freq	10 - 290, 1 step	10 - 100 : 0.10Hz - 1.00Hz, 0.01Hz step 101 - 290 : 1.00Hz - 20.0Hz, 0.1Hz step
feedback level	0 - 1024, 1 step	0 - 100%, 0.0977% step
feedback phase	bit15	0 : normal, 1 : inverse
depth	0 - 1024, 1 step	0 - 100%, 0.0977% step
depth:limit max	"/	"/
input level	"/	"/
input phase	bit15	0 : normal, 1 : inverse
direct level	0 - 1024, 1 step	0 - 100%, 0.0977% step
effect level	"/	"/
direct phase	bit15	0 : normal, 1 : inverse
effect phase	"/	"/

Note) depth  $\leq$  depth:limit max

stereo exciter + EQ :SXE

name	ch	type	data address	comment
stereo exciter + EQ on/off		byte	0	
empty		"/	1	
exciter level	ch1	word	2 - 3	
	ch2	"/	4 - 5	
bass freq	ch1	byte	6	
	ch2	"/	7	
bass level	ch1	"/	8	
	ch2	"/	9	
treble freq	ch1	"/	A	
	ch2	"/	B	
treble level	ch1	"/	C	
	ch2	"/	D	

name	data composition	
stereo exciter + EQ on/off	0 - 1, 1 step	0 : off, 1 : on
exciter level	0 - 512, 1 step	-100 - +100%, 0.39% step
bass freq	4 - 56, 1 step	16Hz - 6.3kHz, 1/6oct step
bass level	0 - 240, 1 step	-12dB - +12dB, 0.1dB step
treble freq	32 - 65, 1 step	400Hz - 18kHz, 1/6oct step
treble level	0 - 240, 1 step	-12dB - +12dB, 0.1dB step

mono exciter + EQ :MXE

name	ch	type	data address	comment
mono exciter + EQ on/off		byte	0	
empty		"/	1	
exciter level		word	2 - 3	
bass freq		byte	4	
bass level		"/	5	
treble freq		"/	6	
treble level		"/	7	
PEQ 1 freq		"/	8	
PEQ 1 level		"/	9	
PEQ 1 q		"/	A	
empty		"/	B	
PEQ 2 freq		"/	C	
PEQ 2 level		"/	D	
PEQ 2 q		"/	E	
empty		"/	F	

name	data composition	
mono exciter + EQ on/off	0 - 1, 1 step	0 : off, 1 : on
exciter level	0 - 512, 1 step	-100% - +100%, 0.39% step
bass freq	4 - 56, 1 step	16Hz - 6.3kHz, 1/6oct step
bass level	0 - 240, 1 step	-12dB - +12dB, 0.1dB step
treble freq	32 - 65, 1 step	400Hz - 18kHz, 1/6oct step
treble level	0 - 240, 1 step	-12dB - +12dB, 0.1dB step
PEQ 1 freq	16 - 65, 1 step	63Hz - 18kHz, 1/6oct step
PEQ 1 level	0 - 240, 1 step	-12dB - +12dB, 0.1dB step
PEQ 1 q	0 - 7, 1 step	0.267 - 34.62
PEQ 2 freq	16 - 65, 1 step	63Hz - 18kHz, 1/6oct step
PEQ 2 level	0 - 240, 1 step	-12dB - +12dB, 0.1dB step
PEQ 2 q	0 - 7, 1 step	0.267 - 34.62



gate :GTE

name	ch	type	data address	comment
gate on/off		byte	0	
empty		"/	1	
trigger select		word	2 - 3	
attack time		"/	4 - 5	
release time		"/	6 - 7	
threshold level		"/	A - B	
hysterisis level		"/	8 - 9	
predelay time	ch1	byte	C	
	ch2	"/	D	

name	data composition	
gate on/off	0 - 1, 1 step	0 : off, 1 : on
trigger select	0 - 2, 1 step	0 : ch1, 1 : ch2, 2 : ch1+ch2
attack time	0 - 500, 1 step	0 - 500ms, 1ms step
release time	0 - 590, 1 step	0 - 500 : 0ms - 500ms, 1ms step 501 - 550 : 510ms - 1000ms, 10ms step 551 - 590 : 1100ms - 5000ms, 100ms step
threshold level	0 - 1024, 1 step	0 - 100%, 0.0977% step
hysterisis level	"/	"/
predelay time	0 - 10, 1 step	0 - 10 words

Note) hysterisis level  $\leq$  threshold level

OUTPUT

name	ch	type	data address	comment
output level	ch1	word	0 - 1	MSB = phase
	ch2	"/	2 - 3	"/
panpot	ch1	"/	4 - 5	
	ch2	"/	6 - 7	
panpot limit min	ch1	"/	8 - 9	
	ch2	"/	A - B	
panpot limit max	ch1	"/	C - D	
	ch2	"/	E - F	

name	data composition	
output level	0 - 1024, 1step	0 - 100%, 0.0977 step
output phase	bit15	0:normal, 1:inverse
panpot	0 - 1024, 1step	0 - 100%, 0.0977 step
panpot limit min	"/	"/
panpot limit max	"/	"/

Note) panpot limit min  $\leq$  panpot  $\leq$  panpot limit max

POST-EF

through :OFF  
NO data

stereo EQ :SEQ  
See PRE-EF.

phase shifter :PHS  
See PRE-EF.

flanger :FLG  
See PRE-EF.

stereo exciter + EQ :SXE  
See PRE-EF.

mono exciter + EQ :MXE

name	ch	type	data address	comment
mono exciter + EQ on/off		byte	0	
empty		"/	1	
exciter level		word	2 - 3	
bass freq		byte	4	
bass level		"/	5	
treble freq		"/	6	
treble level		"/	7	
PEQ 1 freq		"/	8	
PEQ 1 level		"/	9	
PEQ 1 q		"/	A	
empty		"/	B	
PEQ 2 freq		"/	C	
PEQ 2 level		"/	D	
PEQ 2 q		"/	E	
empty		"/	F	
input level	ch1	word	10 - 11	MSB = phase
	ch2	"/	12 - 13	"/

name	data composition	
mono exciter + EQ on/off	0 - 1, 1 step	0 : off, 1 : on
exciter level	0 - 512, 1 step	-100% - +100%, 0.39% step
bass freq	4 - 56, 1 step	16Hz - 6.3kHz, 1/6oct step
bass level	0 - 240, 1 step	-12dB - +12dB, 0.1dB step
treble freq	32 - 65, 1 step	400Hz - 18kHz, 1/6oct step
treble level	0 - 240, 1 step	-12dB - +12dB, 0.1dB step
PEQ 1 freq	16 - 65, 1 step	63Hz - 18kHz, 1/6oct step
PEQ 1 level	0 - 240, 1 step	-12dB - +12dB, 0.1dB step
PEQ 1 q	0 - 7, 1 step	0.267 - 34.62
PEQ 2 freq	16 - 65, 1 step	63Hz - 18kHz, 1/6oct step
PEQ 2 level	0 - 240, 1 step	-12dB - +12dB, 0.1dB step
PEQ 2 q	0 - 7, 1 step	0.267 - 34.62
input level	0 - 1024, 1 step	0 - 100%, 0.0977% step
input phase	bit15	0 : normal, 1 : inverse

gate :GTE

name	ch	type	data address	comment
gate on/off		byte	0	
empty		∕	1	
trigger select		word	2 - 3	
attack time		∕	4 - 5	
release time		∕	6 - 7	
threshold level		∕	A - B	
hysterisis level		∕	8 - 9	
predelay time	ch1	byte	C	
	ch2	∕	D	

name	data composition	
gate on/off	0 - 1, 1 step	0 : off, 1 : on
trigger select	0 - 5, 1 step	0 : pre ch1, 1 : pre ch2, 2 : pre ch1+ch2, 3 : post ch1, 4 : post ch2, 5 : post ch1+ch2
attack time	0 - 500, 1 step	0 - 500ms, 1ms step
release time	0 - 590, 1 step	0 - 500 : 0ms - 500ms, 1ms step 501 - 550 : 510ms - 1000ms, 10ms step 551 - 590 : 1100ms - 5000ms, 100ms step
threshold level	0 - 1024, 1 step	0 - 100%, 0.0977% step
hysterisis level	∕	∕
predelay time	0 - 10, 1 step	0 - 10 words

Note) hysterisis level  $\leq$  threshold level

autopan :APN

name	ch	type	data address	comment
autopan on/off		byte	0	
		/"	1	
LFO freq		word	2 - 3	
autopan limit min		/"	4 - 5	
autopan limit max		/"	6 - 7	
wave select		byte	8	
		/"	9	
phase	ch1,2	/"	A	
trigger select		/"	B	
trigger threshold		word	C - D	
LFO step		/"	E - F	
LFO start point		/"	10 - 11	

name	data composition	
autopan on/off	0 - 1, 1 step	0 : normal, 1 : inverse
LFO freq	10 - 290, 1 step	10 - 100 : 0.10Hz - 1.00Hz, 0.01Hz step 101 - 290 : 1.0Hz - 20.0Hz, 0.1Hz step
autopan limit min	0 - 1024, 1 step	0 - 100%, 0.0977% step
autopan limit max	/"	/"
wave select	0 - 3, 1 step	0 : sin, 1 : triangle, 2 : special1, 3 : special2
phase	bit6 - ch1	0 : normal, 1 : inverse
	bit7 - ch2	0 : normal, 1 : inverse
trigger select	0 - 5, 1 step	0 : off, 1 : pre ch1, 2 : pre ch2, 3 : post ch1,4 : post ch2, 5 : MIDI note on
trigger threshold	0 - 1024, 1 step	0 - 100%, 0.0977% step
LFO step	1 - 360, 1 step	1 - 360 deg., 1deg. step
LFO start point	0 - 359, 1 step	0 - 359 deg., 1deg. step

Note) autopan limit min  $\cong$  autopan limit max

# REVC/REVS Block

through :OFF  
No data

hall reverberation :HLR

name	ch	type	data address	comment
direct level	ch1	word	0 - 1	MSB = phase
	ch2	/"	2 - 3	/"
reverb level	ch1	/"	4 - 5	/"
	ch2	/"	6 - 7	/"
reverb time		/"	8 - 9	
predelay 1 time	ch1	/"	A - B	
	ch2	/"	C - D	
predelay 1 level	ch1	/"	E - F	MSB = phase
	ch2	/"	10 - 11	/"
predelay 2 time	ch1	/"	12 - 13	
predelay 2 level	ch1	/"	14 - 15	
	ch2	/"	16 - 17	MSB = phase
cross predelay time	ch1	/"	18 - 19	/"
	ch2	/"	1A - 1B	
cross predelay level	ch1	/"	1C - 1D	
	ch2	/"	1E - 1F	MSB = phase
early ref.1 time	ch1	/"	20 - 21	/"
	ch2	/"	22 - 23	
early ref.1 level	ch1	/"	24 - 25	
	ch2	/"	26 - 27	MSB = phase
early ref.2 time	ch1	/"	28 - 29	/"
	ch2	/"	2A - 2B	
early ref.2 level	ch1	/"	2C - 2D	
	ch2	/"	2E - 2F	MSB = phase
2nd early ref. time	ch1	/"	30 - 31	/"
	ch2	/"	32 - 33	
2nd early ref. level	ch1	/"	34 - 35	
	ch2	/"	36 - 37	MSB = phase
cross early ref. tim	ch1	/"	38 - 39	/"
	ch2	/"	3A - 3B	
cross early ref. lev	ch1	/"	3C - 3D	
	ch2	/"	3E - 3F	MSB = phase
presence control		/"	40 - 41	/"
rotate high		/"	42 - 43	
rotate bass freq		byte	44 - 45	
rotate bass level		/"	46	
spread		/"	47	
size		/"	48	
		/"	49	

name	data composition	
direct level	0 - 1024, 1 step	0 - 100%, 0.0977% step
reverb level	"/>"	"/>"
direct phase	bit15	0 : normal, 1 : inverse
reverb phase	"/>"	"/>"
reverb time	3 - 189, 1 step	3 - 100 : 0.3sec - 1.0sec, 0.1sec step 101 - 189 : 1.0sec - 99sec, 1sec step
predelay 1 time	1 - 32767, 1 step	1 - 32767words, 1word step
predelay 2 time	"/>"	"/>"
cross predelay time	"/>"	"/>"
early ref.1 time	"/>"	"/>"
early ref.2 time	"/>"	"/>"
2nd early ref. time	"/>"	"/>"
cross early ref. time	"/>"	"/>"
predelay 1 level	0 - 1024, 1 step	0 - 100%, 0.0977% step
predelay 2 level	"/>"	"/>"
cross predelay level	"/>"	"/>"
early ref.1 level	"/>"	"/>"
early ref.2 level	"/>"	"/>"
2nd early ref. level	"/>"	"/>"
cross early ref. level	"/>"	"/>"
predelay 1 phase	bit15	0 : normal, 1 : inverse
predelay 2 phase	"/>"	"/>"
cross predelay phase	"/>"	"/>"
early ref.1 phase	"/>"	"/>"
early ref.2 phase	"/>"	"/>"
2nd early ref. phase	"/>"	"/>"
cross early ref. phase	"/>"	"/>"
presence control	1 - 256, 1 step	0.003 - 1.000, 0.0039 step
rotate high	"/>"	"/>"
rotate bass freq	8 - 56, 1 step (excluding 9 and 11)	25Hz - 6.3kHz, 1/6oct step (excluding 28 Hz and 35.5 Hz)
rotate bass level	0 - 180, 1 step	-12dB - +12dB, 0.1dB step
spread	15 - 25, 1 step	0.5 - 1.5
size	"/>"	"/>"

room reverberation :RMR

name	ch	type	data address	comment
direct level	ch1	word	0 - 1	MSB = phase
	ch2	⋄	2 - 3	⋄
reverb level	ch1	⋄	4 - 5	⋄
	ch2	⋄	6 - 7	⋄
reverb time		⋄	8 - 9	
predelay 1 time	ch1	⋄	A - B	
	ch2	⋄	C - D	
predelay 1 level	ch1	⋄	E - F	MSB = phase
	ch2	⋄	10 - 11	⋄
predelay 2 time	ch1	⋄	12 - 13	
	ch2	⋄	14 - 15	
predelay 2 level	ch1	⋄	16 - 17	MSB = phase
	ch2	⋄	18 - 19	⋄
cross predelay time	ch1	⋄	1A - 1B	
	ch2	⋄	1C - 1D	
cross predelay level	ch1	⋄	1E - 1F	MSB = phase
	ch2	⋄	20 - 21	⋄
early ref.1 time	ch1	⋄	22 - 23	
	ch2	⋄	24 - 25	
early ref.1 level	ch1	⋄	26 - 27	MSB = phase
	ch2	⋄	28 - 29	⋄
early ref.2 time	ch1	⋄	2A - 2B	
	ch2	⋄	2C - 2D	
early ref.2 level	ch1	⋄	2E - 2F	MSB = phase
	ch2	⋄	30 - 31	⋄
2nd early ref. time	ch1	⋄	32 - 33	
	ch2	⋄	34 - 35	
2nd early ref. level	ch1	⋄	36 - 37	MSB = phase
	ch2	⋄	38 - 39	⋄
cross early ref. time	ch1	⋄	3A - 3B	
	ch2	⋄	3C - 3D	
cross early ref. level	ch1	⋄	3E - 3F	MSB = phase
	ch2	⋄	40 - 41	⋄
presence control		⋄	42 - 43	
rotate high		⋄	44 - 45	
rotate bass freq		byte	46	
rotate bass level		⋄	47	
spread		⋄	48	
size		⋄	49	

name	data composition	
direct level	0 - 1024, 1 step	0 - 100%, 0.0977% step
reverb level	"	"
direct phase	bit15	0 : normal, 1 : inverse
reverb phase	"	"
reverb time	3 - 189, 1 step	3 - 100 : 0.12sec - 4.0sec, 0.04sec step 101 - 189 : 4.0sec - 39.60sec, 0.4sec step
predelay 1 time	1 - 32767, 1 step	1 - 32767words, 1word step
predelay 2 time	"	"
cross predelay time	"	"
early ref.1 time	"	"
early ref.2 time	"	"
2nd early ref. time	"	"
cross early ref. time	"	"
predelay 1 level	0 - 1024, 1 step	0 - 100%, 0.0977% step
predelay 2 level	"	"
cross predelay level	"	"
early ref.1 level	"	"
early ref.2 level	"	"
2nd early ref. level	"	"
cross early ref. level	"	"
predelay 1 phase	bit15	0 : normal, 1 : inverse
predelay 2 phase	"	"
cross predelay phase	"	"
early ref.1 phase	"	"
early ref.2 phase	"	"
2nd early ref. phase	"	"
cross early ref. phase	"	"
presence control	1 - 256, 1 step	0.003 - 1.000, 0.0039 step
rotate high	"	"
rotate bass freq	8 - 56, 1 step (excluding 9 and 11)	25Hz - 6.3kHz, 1/6oct step (excluding 28 Hz and 35.5 Hz)
rotate bass level	0 - 180, 1 step	-12dB - +12dB, 0.1dB step
spread	5 - 25, 1 step	0.5 - 2.5
size	5 - 15, 1 step	0.5 - 1.5



## plate reverberation :PLR

name	ch	type	data address	comment
direct level	ch1	word	0 - 1	MSB = phase
	ch2	/"	2 - 3	/"
reverb level	ch1	/"	4 - 5	/"
	ch2	/"	6 - 7	/"
reverb time		/"	8 - 9	
predelay 1 time	ch1	/"	A - B	
	ch2	/"	C - D	
predelay 1 level	ch1	/"	E - F	MSB = phase
	ch2	/"	10 - 11	/"
predelay 2 time	ch1	/"	12 - 13	
	ch2	/"	14 - 15	
predelay 2 level	ch1	/"	16 - 17	MSB = phase
	ch2	/"	18 - 19	/"
2nd predelay time	ch1	/"	1A - 1B	
	ch2	/"	1C - 1D	
2nd predelay level	ch1	/"	1E - 1F	MSB = phase
	ch2	/"	20 - 21	/"
cross predelay time	ch1	/"	22 - 23	
	ch2	/"	24 - 25	
cross predelay level	ch1	/"	26 - 27	MSB = phase
	ch2	/"	28 - 29	/"
2nd cross predelay time	ch1	/"	2A - 2B	
	ch2	/"	2C - 2D	
2nd cross predelay level	ch1	/"	2E - 2F	MSB = phase
	ch2	/"	30 - 31	/"
early ref.1 time	ch1	/"	32 - 33	
	ch2	/"	34 - 35	
early ref.1 level	ch1	/"	36 - 37	MSB = phase
	ch2	/"	38 - 39	/"
early ref.2 time	ch1	/"	3A - 3B	
	ch2	/"	3C - 3D	
early ref.2 level	ch1	/"	3E - 3F	MSB = phase
	ch2	/"	40 - 41	/"
early ref.3 time	ch1	/"	42 - 43	
	ch2	/"	44 - 45	
early ref.3 level	ch1	/"	46 - 47	MSB = phase
	ch2	/"	48 - 49	/"
2nd early ref. time	ch1	/"	4A - 4B	
	ch2	/"	4C - 4D	
2nd early ref. level	ch1	/"	4E - 4F	MSB = phase
	ch2	/"	50 - 51	/"
cross early ref. time	ch1	/"	52 - 53	
	ch2	/"	54 - 55	
cross early ref. level	ch1	/"	56 - 57	MSB = phase
	ch2	/"	58 - 59	/"
presence control		/"	5A - 5B	
rotate high		/"	5C - 5D	
spread		byte	5E	
size		/"	5F	

name	data composition	
direct level	0 - 1024, 1 step	0 - 100%, 0.0977% step
reverb level	"/	"/
direct phase	bit15	0 : normal, 1 : inverse
reverb phase	"/	"/
reverb time	3 - 189, 1 step	3 - 100 : 0.3sec - 1.0sec, 0.1sec step 101 - 189 : 1.0sec - 99sec, 1sec step
predelay 1 time	1 - 22527, 1 step	1 - 22527words, 1word step
predelay 2 time	"/	"/
2nd predelay time	"/	"/
cross predelay time	"/	"/
2nd cross predelay time	"/	"/
early ref.1 time	"/	"/
early ref.2 time	"/	"/
early ref.3 time	"/	"/
2nd early ref. time	"/	"/
cross early ref. time	"/	"/
predelay 1 level	0 - 1024, 1 step	0 - 100%, 0.0977% step
predelay 2 level	"/	"/
2nd predelay level	"/	"/
cross predelay level	"/	"/
2nd cross predelay level	"/	"/
early ref.1 level	"/	"/
early ref.2 level	"/	"/
early ref.3 level	"/	"/
2nd early ref. level	"/	"/
cross early ref. level	"/	"/
predelay 1 phase	bit15	0 : normal, 1 : inverse
predelay 2 phase	"/	"/
2nd predelay phase	"/	"/
cross predelay phase	"/	"/
2nd cross predelay phase	"/	"/
early ref.1 phase	"/	"/
early ref.2 phase	"/	"/
early ref.3 phase	"/	"/
2nd early ref. phase	"/	"/
cross early ref. phase	"/	"/
presence control	1 - 256, 1 step	0.003 - 1.000, 0.0039 step
rotate high	"/	"/
spread	15 - 25, 1 step	0.5 - 1.5
size	"/	"/

gate reverberation :GTR

name	ch	type	data address	comment
direct level	ch1	word	0 - 1	MSB = phase
	ch2	/"	2 - 3	/"
reverb level	ch1	/"	4 - 5	/"
	ch2	/"	6 - 7	/"
gate time	ch1	/"	8 - 9	
	ch2	/"	A - B	
	center	/"	C - D	
envelope form	ch1	/"	E - F	MSB = envelope direction
	ch2	/"	10 - 11	/"
	center	/"	12 - 13	/"
envelope time	ch1	/"	14 - 15	/"
	ch2	/"	16 - 17	
	center	/"	18 - 19	
center output level	ch1	/"	1A - 1B	MSB = phase
	ch2	/"	1C - 1D	/"
release form		/"	1E - 1F	
predelay 1 time	ch1	/"	20 - 21	
	ch2	/"	22 - 23	
predelay 1 level	ch1	/"	24 - 25	MSB = phase
	ch2	/"	26 - 27	/"
predelay 2 time	ch1	/"	28 - 29	
	ch2	/"	2A - 2B	
predelay 2 level	ch1	/"	2C - 2D	MSB = phase
	ch2	/"	2E - 2F	/"
center predelay time	ch1	/"	30 - 31	
	ch2	/"	32 - 33	
center predelay level	ch1	/"	34 - 35	MSB = phase
	ch2	/"	36 - 37	/"
early ref. time	ch1	/"	38 - 39	
	ch2	/"	3A - 3B	
early ref. level	ch1	/"	3C - 3D	MSB = phase
	ch2	/"	3E - 3F	/"
presence control		/"	40 - 41	
spread		byte	42	
size		/"	43	

name	data composition	
direct level	0 - 1024, 1 step	0 - 100%, 0.0977% step
reverb level	"/	"/
direct phase	bit15	0 : normal, 1 : inverse
reverb phase	"/	"/
gate time	1 - 16383, 1 step	1 - 16383words, 1word step
envelope form	0 - 3, 1 step	0 : linear1, 1 : linear2, 2 : exp.1, 3 : exp.2
envelope directin	bit15	0 : normal, 1 : reverse
envelope time	1 - 9999, 1 step	10ms - 99.99sec, 10ms step
center output level	0 - 1024, 1 step	0 - 100%, 0.0977% step
center output phase	bit15	0 : normal, 1 : inverse
release form	1 - 20, 1 step	5 - 100, 5 step
predelay 1 time	1 - 30719, 1 step	1 - 30719words, 1word step
predelay 2 time	"/	"/
center predelay time	"/	"/
early ref. time	"/	"/
predelay 1 level	0 - 1024, 1 step	0 - 100%, 0.0977% step
predelay 2 level	"/	"/
center predelay level	"/	"/
early ref. level	"/	"/
predelay 1 phase	bit15	0 : normal, 1 : inverse
predelay 2 phase	"/	"/
center predelay phase	"/	"/
early ref. phase	"/	"/
presence control	1 - 256, 1 step	0.003 - 1.000, 0.0039 step
spread	5 - 25, 1 step	0.5 - 2.5
size	"/	"/

early reflection :ERF

name	ch	type	data address	comment
direct level	ch1	word	0 - 1	MSB = phase
	ch2	⋄	2 - 3	⋄
reverb level	ch1	⋄	4 - 5	⋄
	ch2	⋄	6 - 7	⋄
predelay time	ch1	⋄	8 - 9	
	ch2	⋄	A - B	
predelay level	ch1	⋄	C - D	MSB = phase
	ch2	⋄	E - F	⋄
send CH1-CH2 level		⋄	10 - 11	⋄
early ref.1 time	ch1	⋄	12 - 13	
	ch2	⋄	14 - 15	
early ref.1 level	ch1	⋄	16 - 17	MSB = phase
	ch2	⋄	18 - 19	⋄
early ref.2 time	ch1	⋄	1A - 1B	
	ch2	⋄	1C - 1D	
early ref.2 level	ch1	⋄	1E - 1F	MSB = phase
	ch2	⋄	20 - 21	⋄
early ref.3 time	ch1	⋄	22 - 23	
	ch2	⋄	24 - 25	
early ref.3 level	ch1	⋄	26 - 27	MSB = phase
	ch2	⋄	28 - 29	⋄
early ref.4 time	ch1	⋄	2A - 2B	
	ch2	⋄	2C - 2D	
early ref.4 level	ch1	⋄	2E - 2F	MSB = phase
	ch2	⋄	30 - 31	⋄
early ref.5 time	ch1	⋄	32 - 33	
	ch2	⋄	34 - 35	
early ref.5 level	ch1	⋄	36 - 37	MSB = phase
	ch2	⋄	38 - 39	⋄
early ref.6 time	ch1	⋄	3A - 3B	
	ch2	⋄	3C - 3D	
early ref.6 level	ch1	⋄	3E - 3F	MSB = phase
	ch2	⋄	40 - 41	⋄
early ref.7 time	ch1	⋄	42 - 43	
	ch2	⋄	44 - 45	
early ref.7 level	ch1	⋄	46 - 47	MSB = phase
	ch2	⋄	48 - 49	⋄
early ref.8 time	ch1	⋄	4A - 4B	
	ch2	⋄	4C - 4D	
early ref.8 level	ch1	⋄	4E - 4F	MSB = phase
	ch2	⋄	50 - 51	⋄
early ref.9 time	ch1	⋄	52 - 53	
	ch2	⋄	54 - 55	
early ref.9 level	ch1	⋄	56 - 57	MSB = phase
	ch2	⋄	58 - 59	⋄
early ref.10 time	ch1	⋄	5A - 5B	
	ch2	⋄	5C - 5D	
early ref.10 level	ch1	⋄	5E - 5F	MSB = phase
	ch2	⋄	60 - 61	⋄
early ref.11 time	ch1	⋄	62 - 63	
	ch2	⋄	64 - 65	
early ref.11 level	ch1	⋄	66 - 67	MSB = phase
	ch2	⋄	68 - 69	⋄

name	ch	type	data address	comment
early ref.12 time	ch1	word	6A - 6B	
	ch2	⋄	6C - 6D	
early ref.12 level	ch1	⋄	6E - 6F	MSB = phase
	ch2	⋄	70 - 71	⋄
early ref.13 time	ch1	⋄	72 - 73	
	ch2	⋄	74 - 75	
early ref.13 level	ch1	⋄	76 - 77	MSB = phase
	ch2	⋄	78 - 79	⋄
early ref.14 time	ch1	⋄	7A - 7B	
	ch2	⋄	7C - 7D	
early ref.14 level	ch1	⋄	7E - 7F	MSB = phase
	ch2	⋄	80 - 81	⋄
early ref.15 time	ch1	⋄	82 - 83	
	ch2	⋄	84 - 85	
early ref.15 level	ch1	⋄	86 - 87	MSB = phase
	ch2	⋄	88 - 89	⋄
early ref.16 time	ch1	⋄	8A - 8B	
	ch2	⋄	8C - 8D	
early ref.16 level	ch1	⋄	8E - 8F	MSB = phase
	ch2	⋄	90 - 91	⋄
early ref.17 time	ch1	⋄	92 - 93	
	ch2	⋄	94 - 95	
early ref.17 level	ch1	⋄	96 - 97	MSB = phase
	ch2	⋄	98 - 99	⋄
early ref.18 time	ch1	⋄	9A - 9B	
	ch2	⋄	9C - 9D	
early ref.18 level	ch1	⋄	9E - 9F	MSB = phase
	ch2	⋄	A0 - A1	⋄
early ref.19 time	ch1	⋄	A2 - A3	
	ch2	⋄	A4 - A5	
early ref.19 level	ch1	⋄	A6 - A7	MSB = phase
	ch2	⋄	A8 - A9	⋄
early ref.20 time	ch1	⋄	AA - AB	
	ch2	⋄	AC - AD	
early ref.20 level	ch1	⋄	AE - AF	MSB = phase
	ch2	⋄	B0 - B1	⋄
early ref.21 time	ch1	⋄	B2 - B3	
	ch2	⋄	B4 - B5	
early ref.21 level	ch1	⋄	B6 - B7	MSB = phase
	ch2	⋄	B8 - B9	⋄
early ref.22 time	ch1	⋄	BA - BB	
	ch2	⋄	BC - BD	
early ref.22 level	ch1	⋄	BE - BF	MSB = phase
	ch2	⋄	C0 - C1	⋄
early ref.23 time	ch1	⋄	C2 - C3	
	ch2	⋄	C4 - C5	
early ref.23 level	ch1	⋄	C6 - C7	MSB = phase
	ch2	⋄	C8 - C9	⋄
early ref.24 time	ch1	⋄	CA - CB	
	ch2	⋄	CC - CD	
early ref.24 level	ch1	⋄	CE - CF	MSB = phase
	ch2	⋄	D0 - D1	⋄
early ref.25 time	ch1	⋄	D2 - D3	
	ch2	⋄	D4 - D5	
early ref.25 level	ch1	⋄	D6 - D7	MSB = phase
	ch2	⋄	D8 - D9	⋄

name	ch	type	data address	comment
early ref.26 time	ch1	word	DA - DB	
	ch2	⌘	DC - DD	
early ref.26 level	ch1	⌘	DE - DF	MSB = phase
	ch2	⌘	E0 - E1	⌘
early ref.27 time	ch1	⌘	E2 - E3	
	ch2	⌘	E4 - E5	
early ref.27 level	ch1	⌘	E6 - E7	MSB = phase
	ch2	⌘	E8 - E9	⌘
early ref.28 time	ch1	⌘	EA - EB	
	ch2	⌘	EC - ED	
early ref.28 level	ch1	⌘	EE - EF	MSB = phase
	ch2	⌘	F0 - F1	⌘
early ref.29 time	ch1	⌘	F2 - F3	
	ch2	⌘	F4 - F5	
early ref.29 level	ch1	⌘	F6 - F7	MSB = phase
	ch2	⌘	F8 - F9	⌘
early ref.30 time	ch1	⌘	FA - FB	
	ch2	⌘	FC - FD	
early ref.30 level	ch1	⌘	FE - FF	MSB = phase
	ch2	⌘	100 - 101	⌘
early ref.31 time	ch1	⌘	102 - 103	
	ch2	⌘	104 - 105	
early ref.31 level	ch1	⌘	106 - 107	MSB = phase
	ch2	⌘	108 - 109	⌘
early ref.32 time	ch1	⌘	10A - 10B	
	ch2	⌘	10C - 10D	
early ref.32 level	ch1	⌘	10E - 10F	MSB = phase
	ch2	⌘	110 - 111	⌘
early ref.33 time	ch1	⌘	112 - 113	
	ch2	⌘	114 - 115	
early ref.33 level	ch1	⌘	116 - 117	MSB = phase
	ch2	⌘	118 - 119	⌘
early ref.34 time	ch1	⌘	11A - 11B	
	ch2	⌘	11C - 11D	
early ref.34 level	ch1	⌘	11E - 11F	MSB = phase
	ch2	⌘	120 - 121	⌘
early ref.35 time	ch1	⌘	122 - 123	
	ch2	⌘	124 - 125	
early ref.35 level	ch1	⌘	126 - 127	MSB = phase
	ch2	⌘	128 - 129	⌘
early ref.36 time	ch1	⌘	12A - 12B	
	ch2	⌘	12C - 12D	
early ref.36 level	ch1	⌘	12E - 12F	MSB = phase
	ch2	⌘	130 - 131	⌘
early ref.37 time	ch1	⌘	132 - 133	
	ch2	⌘	134 - 135	
early ref.37 level	ch1	⌘	136 - 137	MSB = phase
	ch2	⌘	138 - 139	⌘
early ref.38 time	ch1	⌘	13A - 13B	
	ch2	⌘	13C - 13D	
early ref.38 level	ch1	⌘	13E - 13F	MSB = phase
	ch2	⌘	140 - 141	⌘
early ref.39 time	ch1	⌘	142 - 143	
	ch2	⌘	144 - 145	
early ref.39 level	ch1	⌘	146 - 147	MSB = phase
	ch2	⌘	148 - 149	⌘

name	ch	type	data address	comment
early ref.40 time	ch1	word	14A - 14B	
	ch2	◇	14C - 14D	
early ref.40 level	ch1	◇	14E - 14F	MSB = phase
	ch2	◇	150 - 151	◇
early ref.41 time	ch1	◇	152 - 153	
	ch2	◇	154 - 155	
early ref.41 level	ch1	◇	156 - 157	MSB = phase
	ch2	◇	158 - 159	◇
early ref.42 time	ch1	◇	15A - 15B	
	ch2	◇	15C - 15D	
early ref.42 level	ch1	◇	15E - 15F	MSB = phase
	ch2	◇	160 - 161	◇
early ref.43 time	ch1	◇	162 - 163	
	ch2	◇	164 - 165	
early ref.43 level	ch1	◇	166 - 167	MSB = phase
	ch2	◇	168 - 169	◇
early ref.44 time	ch1	◇	16A - 16B	
	ch2	◇	16C - 16D	
early ref.44 level	ch1	◇	16E - 16F	MSB = phase
	ch2	◇	170 - 171	◇
early ref.45 time	ch1	◇	172 - 173	
	ch2	◇	174 - 175	
early ref.45 level	ch1	◇	176 - 177	MSB = phase
	ch2	◇	178 - 179	◇
early ref.46 time	ch1	◇	17A - 17B	
	ch2	◇	17C - 17D	
early ref.46 level	ch1	◇	17E - 17F	MSB = phase
	ch2	◇	180 - 181	◇
early ref.47 time	ch1	◇	182 - 183	
	ch2	◇	184 - 185	
early ref.47 level	ch1	◇	186 - 187	MSB = phase
	ch2	◇	188 - 189	◇
early ref.48 time	ch1	◇	18A - 18B	
	ch2	◇	18C - 18D	
early ref.48 level	ch1	◇	18E - 18F	MSB = phase
	ch2	◇	190 - 191	◇

name	data composition	
direct level	0 - 1024, 1 step	0 - 100%, 0.0977% step
reverb level	◇	◇
direct phase	bit15	0 : normal, 1 : inverse
reverb phase	◇	◇
predelay time	1 - 32767, 1 step	1 - 32767 words, 1 word step
predelay level	0 - 1024, 1 step	0 - 100%, 0.0977% step
predelay phase	bit15	0 : normal, 1 : inverse
send CH1-CH2 level	0 - 1024, 1 step	0 - 100%, 0.0977% step
send CH1-CH2 phase	bit15	0 : normal, 1 : inverse
early ref.1 - 48 time	1 - 32767, 1 step	1 - 32767 words, 1 word step
early ref.1 - 48 level	0 - 1024, 1 step	0 - 100%, 0.0977% step
early ref.1 - 48 phase	bit15	0 : normal, 1 : inverse



# REVC/REV1 Block

plate reverberation :PLR

name	ch	type	data address	comment
reverb level	ch1	word	0 - 1	MSB = phase
	ch2	"	2 - 3	"
send level	ch1	"	4 - 5	"
	ch2	"	6 - 7	"
reverb time		"	8 - 9	
predelay time		"	A - B	
predelay level		"	C - D	MSB = phase
2nd predelay time		"	E - F	
2nd predelay level		"	10 - 11	MSB = phase
early ref. time	ch1	"	12 - 13	
	ch2	"	14 - 15	
early ref. level	ch1	"	16 - 17	MSB = phase
	ch2	"	18 - 19	"
rotate high		"	1A - 1B	
spread		byte	1C	
size		"	1D	
center phase		word	1E - 1F	MSB = phase

name	data composition	
reverb level	0 - 1024, 1 step	0 - 100%, 0.0977% step
send level	"	"
reverb phase	bit15	0 : normal, 1 : inverse
send phase	"	"
reverb time	3 - 189, 1 step	3 - 100 : 0.3sec - 1.0sec, 0.1sec step
		101 - 189 : 1.0sec - 99sec, 1sec step
predelay time	1 - 19199, 1 step	1 - 19199words, 1word step
2nd predelay time	"	"
early ref. time	"	"
predelay level	0 - 1024, 1 step	1 - 100%, 0.0977% step
2nd predelay level	"	"
early ref. level	"	"
predelay phase	bit15	0 : normal, 1 : inverse
2nd predelay phase	"	"
early ref. phase	"	"
rotate high	1 - 256, 1 step	0.003 - 1.000, 0.0039 step
spread	15 - 25, 1 step	0.5 - 1.5
size	"	"
center phase	bit15	0 : normal, 1 : inverse

gate reverberation :GTR

name	ch	type	data address	comment
reverb level	ch1	word	0 - 1	MSB = phase
	ch2	/"	2 - 3	/"
send level	ch1	/"	4 - 5	/"
	ch2	/"	6 - 7	/"
gate time	ch1	/"	8 - 9	
	ch2	/"	A - B	
envelope form	ch1	/"	C - D	MSB = env.dir.
	ch2	/"	E - F	/"
envelope time	ch1	/"	10 - 11	
	ch2	/"	12 - 13	
release form		/"	14 - 15	
predelay 1 time		/"	16 - 17	
predelay 1 level		/"	18 - 19	MSB = phase
predelay 2 time		/"	1A - 1B	
predelay 2 level		/"	1C - 1D	MSB = phase
early ref. time	ch1	/"	1E - 1F	
	ch2	/"	20 - 21	
early ref. level	ch1	/"	22 - 23	MSB = phase
	ch2	/"	24 - 25	/"
spread		byte	26	
size		/"	27	

name	data composition	
reverb level	0 - 1024, 1 step	0 - 100%, 0.0977% step
send level	/"	/"
reverb phase	bit15	0 : normal, 1 : inverse
send phase	/"	/"
gate time	1 - 20480, 1 step	1 - 20480words, 1word step
envelope form	0 - 3, 1 step	0 : linear1, 1 : linear2, 2 : exp.1, 3 : exp.2
envelope direction	bit15	0 : normal, 1 : reverse
envelope time	1 - 9999, 1 step	10ms - 99.99sec, 10ms step
release form	1 - 20, 1 step	5 - 100, 5 step
predelay 1 time	1 - 32767, 1 step	1 - 32767words, 1word step
predelay 2 time	/"	/"
early ref. time	/"	/"
predelay 1 level	0 - 1024, 1 step	0 - 100%, 0.0977% step
predelay 2 level	/"	/"
early ref. level	/"	/"
predelay 1 phase	bit15	0 : normal, 1 : inverse
predelay 2 phase	/"	/"
early ref. phase	/"	/"
spread	5 - 25, 1step	0.5 - 2.5
size	/"	/"

early reflection :ERF

name	ch	type	data address	comment
reverb level	ch1	word	0 - 1	MSB = phase
	ch2	⋄	2 - 3	⋄
send level	ch1	⋄	4 - 5	⋄
	ch2	⋄	6 - 7	⋄
predelay time		⋄	8 - 9	
predelay level		⋄	A - B	MSB = phase
early ref.1 time	ch1	⋄	C - D	
	ch2	⋄	E - F	
early ref.1 level	ch1	⋄	10 - 11	MSB = phase
	ch2	⋄	12 - 13	⋄
early ref.2 time	ch1	⋄	14 - 15	
	ch2	⋄	16 - 17	
early ref.2 level	ch1	⋄	18 - 19	MSB = phase
	ch2	⋄	1A - 1B	⋄
early ref.3 time	ch1	⋄	1C - 1D	
	ch2	⋄	1E - 1F	
early ref.3 level	ch1	⋄	20 - 21	MSB = phase
	ch2	⋄	22 - 23	⋄
early ref.4 time	ch1	⋄	24 - 25	
	ch2	⋄	26 - 27	
early ref.4 level	ch1	⋄	28 - 29	MSB = phase
	ch2	⋄	2A - 2B	⋄
early ref.5 time	ch1	⋄	2C - 2D	
	ch2	⋄	2E - 2F	
early ref.5 level	ch1	⋄	30 - 31	MSB = phase
	ch2	⋄	32 - 33	⋄
early ref.6 time	ch1	⋄	34 - 35	
	ch2	⋄	36 - 37	
early ref.6 level	ch1	⋄	38 - 39	MSB = phase
	ch2	⋄	3A - 3B	⋄
early ref.7 time	ch1	⋄	3C - 3D	
	ch2	⋄	3E - 3F	
early ref.7 level	ch1	⋄	40 - 41	MSB = phase
	ch2	⋄	42 - 43	⋄
early ref.8 time	ch1	⋄	44 - 45	
	ch2	⋄	46 - 47	
early ref.8 level	ch1	⋄	48 - 49	MSB = phase
	ch2	⋄	4A - 4B	⋄
early ref.9 time	ch1	⋄	4C - 4D	
	ch2	⋄	4E - 4F	
early ref.9 level	ch1	⋄	50 - 51	MSB = phase
	ch2	⋄	52 - 53	⋄
early ref.10 time	ch1	⋄	54 - 55	
	ch2	⋄	56 - 57	
early ref.10 level	ch1	⋄	58 - 59	MSB = phase
	ch2	⋄	5A - 5B	⋄
early ref.11 time	ch1	⋄	5C - 5D	
	ch2	⋄	5E - 5F	
early ref.11 level	ch1	⋄	60 - 61	MSB = phase
	ch2	⋄	62 - 63	⋄
early ref.12 time	ch1	⋄	64 - 65	
	ch2	⋄	66 - 67	
early ref.12 level	ch1	⋄	68 - 69	MSB = phase
	ch2	⋄	6A - 6B	⋄

name	ch	type	data address	comment
early ref.13 time	ch1	∕	6C - 6D	
	ch2	∕	6E - 6F	
early ref.13 level	ch1	∕	70 - 71	MSB = phase
	ch2	∕	72 - 73	∕
early ref.14 time	ch1	∕	74 - 75	
	ch2	∕	76 - 77	
early ref.14 level	ch1	∕	78 - 79	MSB = phase
	ch2	∕	7A - 7B	∕
early ref.15 time	ch1	∕	7C - 7D	
	ch2	∕	7E - 7F	
early ref.15 level	ch1	∕	80 - 81	MSB = phase
	ch2	∕	82 - 83	∕
early ref.16 time	ch1	∕	84 - 85	
	ch2	∕	86 - 87	
early ref.16 level	ch1	∕	88 - 89	MSB = phase
	ch2	∕	8A - 8B	∕
early ref.17 time	ch1	∕	8C - 8D	
	ch2	∕	8E - 8F	
early ref.17 level	ch1	∕	90 - 91	MSB = phase
	ch2	∕	92 - 93	∕
early ref.18 time	ch1	∕	94 - 95	
	ch2	∕	96 - 97	
early ref.18 level	ch1	∕	98 - 99	MSB = phase
	ch2	∕	9A - 9B	∕
early ref.19 time	ch1	∕	9C - 9D	
	ch2	∕	9E - 9F	
early ref.19 level	ch1	∕	A0 - A1	MSB = phase
	ch2	∕	A2 - A3	∕
early ref.20 time	ch1	∕	A4 - A5	
	ch2	∕	A6 - A7	
early ref.20 level	ch1	∕	A8 - A9	MSB = phase
	ch2	∕	AA - AB	∕
early ref.21 time	ch1	∕	AC - AD	
	ch2	∕	AE - AF	
early ref.21 level	ch1	∕	B0 - B1	MSB = phase
	ch2	∕	B2 - B3	∕
early ref.22 time	ch1	∕	B4 - B5	
	ch2	∕	B6 - B7	
early ref.22 level	ch1	∕	B8 - B9	MSB = phase
	ch2	∕	BA - BB	∕
early ref.23 time	ch1	∕	BC - BD	
	ch2	∕	BE - BF	
early ref.23 level	ch1	∕	C0 - C1	MSB = phase
	ch2	∕	C2 - C3	∕

name	data composition	
reverb level	0 - 1024, 1 step	0 - 100%, 0.0977% step
send level	"/	"/
reverb phase	bit15	0 : normal, 1 : inverse
send phase	"/	"/
predelay time	1 - 32767, 1 step	1 - 32767words, 1word step
predelay level	0 - 1024, 1 step	0 - 100%, 0.0977% step
early ref.1 - 23 time	1 - 32766, 1 step	1 - 32766words, 1word step
early ref.1 - 23 level	0 - 1024, 1 step	0 - 100%, 0.0977% step
early ref.1 - 23 phase	bit15	0 : normal, 1 : inverse

delay 1 :DL1

name	ch	type	data address	comment
reverb level	ch1	word	0 - 1	MSB = phase
	ch2	"/	2 - 3	"/
send level	ch1	"/	4 - 5	"/
	ch2	"/	6 - 7	"/
tap 1 time	ch1	"/	8 - 9	
	ch2	"/	A - B	
tap 1 level	ch1	"/	C - D	MSB = phase
	ch2	"/	E - F	"/
tap 2 time	ch1	"/	10 - 11	
	ch2	"/	12 - 13	
tap 2 level	ch1	"/	14 - 15	MSB = phase
	ch2	"/	16 - 17	"/
feedback time		"/	18 - 19	
feedback level		"/	1A - 1B	MSB = phase
rotate PEQ freq		byte	1C	
rotate PEQ level		"/	1D	
rotate PEQ q		"/	1E	
empty		"/	1F	
rotate bass freq		"/	20	
rotate bass level		"/	21	
rotate treble freq		"/	22	
rotate treble level		"/	23	
bass freq	ch1	"/	24	
	ch2	"/	25	
bass level	ch1	"/	26	
	ch2	"/	27	
treble freq	ch1	"/	28	
	ch2	"/	29	
treble level	ch1	"/	2A	
	ch2	"/	2B	
dry output level	ch1	word	2C - 2D	MSB = phase
	ch2	"/	2E - 2F	"/

name	data composition	
reverb level	0 - 1024, 1 step	0 - 100%, 0.0977% step
send level	"/	"/
reverb phase	bit15	0 : normal, 1 : inverse
send phase	"/	"/
tap 1 time	1 - 65516, 1 step	1 - 65516words, 1word step
tap 2 time	"/	"/
feedback time	"/	"/
tap 1 level	0 - 1024, 1 step	0 - 100%, 0.0977% step
tap 2 level	"/	"/
feedback level	"/	"/
tap 1 phase	bit15	0 : normal, 1 : inverse
tap 2 phase	"/	"/
feedback phase	"/	"/
rotate PEQ freq	26 - 65, 1 step (excluding 27,28,31)	200Hz - 18kHz, 1/6oct step (excluding 225Hz,250Hz,355Hz)
rotate PEQ level	0 - 180, 1 step	-12dB - +6dB, 0.1dB step
rotate PEQ q	0 - 6, 1 step	0.267 - 17.31
rotate bass freq	8 - 56, 1 step (excluding 9 and 11)	25Hz - 6.3kHz, 1/6oct step (excluding 28 Hz and 35.5 Hz)
rotate bass level	0 - 180, 1 step	-12dB - +6dB, 0.1dB step
rotate treble freq	20 - 65, 1 step	100Hz - 18kHz, 1/6oct step
rotate treble level	0 - 180, 1 step	-12dB - +6dB, 0.1dB step
bass freq	8 - 56, 1 step (excluding 9 and 11)	25Hz - 6.3kHz, 1/6oct step (excluding 28 Hz and 35.5 Hz)
bass level	0 - 180, 1 step	-12dB - +6dB, 0.1dB step
treble freq	20 - 65, 1 step	100Hz - 18kHz, 1/6oct step
treble level	0 - 180, 1 step	-12dB - +6dB, 0.1dB step
dry output level	0 - 1024, 1 step	0 - 100%, 0.0977% step
dry output phase	bit15	0 : normal, 1 : inverse

delay 2 :DL2

name	ch	type	data address	comment
reverb level	ch1	word	0 - 1	MSB = phase
	ch2	⋄	2 - 3	⋄
send level	ch1	⋄	4 - 5	⋄
	ch2	⋄	6 - 7	⋄
predelay time		⋄	8 - 9	
predelay level		⋄	A - B	MSB = phase
predelay feedback level		⋄	C - D	⋄
predelay RT bass freq		byte	E	
predelay RT bass level		⋄	F	
predelay RT treble freq		⋄	10	
predelay RT treble level		⋄	11	
maindelay in PD level	ch1	word	12 - 13	MSB = phase
	ch2	⋄	14 - 15	⋄
maindelay in dry level	ch1	⋄	16 - 17	MSB = phase
	ch2	⋄	18 - 19	⋄
delay feedback time	ch1	⋄	1A - 1B	
	ch2	⋄	1C - 1D	
delay feedback level	ch1	⋄	1E - 1F	MSB = phase
	ch2	⋄	20 - 21	⋄
delay RT bass freq	ch1	byte	22	
	ch2	⋄	23	
delay RT bass level	ch1	⋄	24	
	ch2	⋄	25	
delay RT treble freq	ch1	⋄	26	
	ch2	⋄	27	
delay RT treble level	ch1	⋄	28	
	ch2	⋄	29	
dry output level	ch1	word	2A - 2B	MSB = phase
	ch2	⋄	2C - 2D	⋄

name	data composition	
reverb level	0 - 1024, 1 step	0 - 100%, 0.0977% step
send level	"	"
reverb phase	bit15	0 : normal, 1 : inverse
send phase	"	"
predelay time	1 - 16375, 1 step	1 - 16375words, 1word step
predelay level	0 - 1024, 1 step	0 - 100%, 0.0977% step
predelay feedback level	"	"
predelay phase	bit15	0 : normal, 1 : inverse
predelay feedback phase	"	"
predelay RT bass freq	8 - 56, 1 step (excluding 9 and 11)	25Hz - 6.3kHz, 1/6oct step (excluding 28 Hz and 35.5 Hz)
predelay RT bass level	0 - 180, 1 step	-12dB - +6dB, 0.1dB step
predelay RT treble freq	20 - 65, 1 step	100Hz - 18kHz, 1/6oct step
predelay RT treble level	0 - 180, 1 step	-12dB - +6dB, 0.1dB step
maindelay in PD level	0 - 1024, 1 step	0 - 100%, 0.0977% step
maindelay in dry level	"	"
delay feedback time	1 - 16379, 1 step	1 - 16379words, 1word step
delay feedback level	0 - 1024, 1 step	0 - 100%, 0.0977% step
delay RT bass freq	8 - 56, 1 step (excluding 9 and 11)	25Hz - 6.3kHz, 1/6oct step (excluding 28 Hz and 35.5 Hz)
delay RT bass level	0 - 180, 1 step	-12dB - +6dB, 0.1dB step
delay RT treble freq	20 - 65, 1 step	100Hz - 18kHz, 1/6oct step
delay RT treble level	0 - 180, 1 step	-12dB - +6dB, 0.1dB step
dry output level	0 - 1024, 1 step	0 - 100%, 0.0977% step
dry output phase	bit15	0 : normal, 1 : inverse



# REVC/REV2 Block

plate reverberation :PLR

name	ch	type	data address	comment
direct level	ch1	word	0 - 1	MSB = phase
	ch2	⋄	2 - 3	⋄
REV1 output level	ch1	⋄	4 - 5	MSB = phase
	ch2	⋄	6 - 7	⋄
reverb time		⋄	8 - 9	
predelay time		⋄	A - B	
predelay level		⋄	C - D	MSB = phase
2nd predelay time		⋄	E - F	
2nd predelay level		⋄	10 - 11	MSB = phase
early ref. time	ch1	⋄	12 - 13	
	ch2	⋄	14 - 15	
early ref. level	ch1	⋄	16 - 17	MSB = phase
	ch2	⋄	18 - 19	⋄
rotate high		⋄	1A - 1B	
spread		byte	1C	
size		⋄	1D	
center phase		word	1E - 1F	MSB = phase

name	data composition	
direct level	0 - 1024, 1 step	0 - 100%, 0.0977% step
REV1 output level	⋄	⋄
direct phase	bit15	0 : normal, 1 : inverse
REV1 output phase	⋄	⋄
reverb time	3 - 189, 1 step	3 - 100 : 0.3sec - 1.0sec, 0.1sec step 101 - 189 : 1.0sec - 99sec, 1sec step
predelay time	1 - 19199, 1 step	1 - 19199words, 1word step
2nd predelay time	⋄	⋄
early ref. time	⋄	⋄
predelay level	0 - 1024, 1 step	1 - 100%, 0.0977% step
2nd predelay level	⋄	⋄
early ref. level	⋄	⋄
predelay phase	bit15	0 : normal, 1 : inverse
2nd predelay phase	⋄	⋄
early ref. phase	⋄	⋄
rotate high	1 - 256, 1 step	0.003 - 1.000, 0.0039 step
spread	15 - 25, 1 step	0.5 - 1.5
size	⋄	⋄
center phase	bit15	0 : normal, 1 : inverse

gate reverberation :GTR

name	ch	type	data address	comment
direct level	ch1	word	0 - 1	MSB = phase
	ch2	/"	2 - 3	/"
REV1 output level	ch1	/"	4 - 5	MSB = phase
	ch2	/"	6 - 7	/"
gate time	ch1	/"	8 - 9	
	ch2	/"	A - B	
envelope form	ch1	/"	C - D	MSB = env.dir.
	ch2	/"	E - F	/"
envelope time	ch1	/"	10 - 11	
	ch2	/"	12 - 13	
release form		/"	14 - 15	
predelay 1 time		/"	16 - 17	
predelay 1 level		/"	18 - 19	MSB = phase
predelay 2 time		/"	1A - 1B	
predelay 2 level		/"	1C - 1D	MSB = phase
early ref. time	ch1	/"	1E - 1F	
	ch2	/"	20 - 21	
early ref. level	ch1	/"	22 - 23	MSB = phase
	ch2	/"	24 - 25	/"
spread		byte	26	
size		/"	27	

name	data composition	
direct level	0 - 1024, 1 step	0 - 100%, 0.0977% step
REV1 output level	/"	/"
direct phase	bit15	0 : normal, 1 : inverse
REV1 output phase	/"	/"
gate time	1 - 20480, 1 step	1 - 20480words, 1word step
envelope form	0 - 3, 1 step	0 : linear1, 1 : linear2, 2 : exp.1, 3 : exp.2
envelope direction	bit15	0 : normal, 1 : reverse
envelope time	1 - 9999, 1 step	10ms - 99.99sec, 10ms step
release form	1 - 20, 1 step	5 - 100, 5 step
predelay 1 time	1 - 32767, 1 step	1 - 32767words, 1word step
predelay 2 time	/"	/"
early ref. time	/"	/"
predelay 1 level	0 - 1024, 1 step	0 - 100%, 0.0977% step
predelay 2 level	/"	/"
early ref. level	/"	/"
predelay 1 phase	bit15	0 : normal, 1 : inverse
predelay 2 phase	/"	/"
early ref. phase	/"	/"
spread	5 - 25, 1step	0.5 - 2.5
size	/"	/"

early reflection :ERF

name	ch	type	data address	comment
direct level	ch1	word	0 - 1	MSB = phase
	ch2	/"	2 - 3	/"
REV1 output level	ch1	/"	4 - 5	MSB = phase
	ch2	/"	6 - 7	/"
predelay time		/"	8 - 9	
predelay level		/"	A - B	MSB = phase
early ref.1 time	ch1	/"	C - D	
	ch2	/"	E - F	
early ref.1 level	ch1	/"	10 - 11	MSB = phase
	ch2	/"	12 - 13	/"
early ref.2 time	ch1	/"	14 - 15	
	ch2	/"	16 - 17	
early ref.2 level	ch1	/"	18 - 19	MSB = phase
	ch2	/"	1A - 1B	/"
early ref.3 time	ch1	/"	1C - 1D	
	ch2	/"	1E - 1F	
early ref.3 level	ch1	/"	20 - 21	MSB = phase
	ch2	/"	22 - 23	/"
early ref.4 time	ch1	/"	24 - 25	
	ch2	/"	26 - 27	
early ref.4 level	ch1	/"	28 - 29	MSB = phase
	ch2	/"	2A - 2B	/"
early ref.5 time	ch1	/"	2C - 2D	
	ch2	/"	2E - 2F	
early ref.5 level	ch1	/"	30 - 31	MSB = phase
	ch2	/"	32 - 33	/"
early ref.6 time	ch1	/"	34 - 35	
	ch2	/"	36 - 37	
early ref.6 level	ch1	/"	38 - 39	MSB = phase
	ch2	/"	3A - 3B	/"
early ref.7 time	ch1	/"	3C - 3D	
	ch2	/"	3E - 3F	
early ref.7 level	ch1	/"	40 - 41	MSB = phase
	ch2	/"	42 - 43	/"
early ref.8 time	ch1	/"	44 - 45	
	ch2	/"	46 - 47	
early ref.8 level	ch1	/"	48 - 49	MSB = phase
	ch2	/"	4A - 4B	/"
early ref.9 time	ch1	/"	4C - 4D	
	ch2	/"	4E - 4F	
early ref.9 level	ch1	/"	50 - 51	MSB = phase
	ch2	/"	52 - 53	/"
early ref.10 time	ch1	/"	54 - 55	
	ch2	/"	56 - 57	
early ref.10 level	ch1	/"	58 - 59	MSB = phase
	ch2	/"	5A - 5B	/"
early ref.11 time	ch1	/"	5C - 5D	
	ch2	/"	5E - 5F	
early ref.11 level	ch1	/"	60 - 61	MSB = phase
	ch2	/"	62 - 63	/"
early ref.12 time	ch1	/"	64 - 65	
	ch2	/"	66 - 67	
early ref.12 level	ch1	/"	68 - 69	MSB = phase
	ch2	/"	6A - 6B	/"

name	ch	type	data address	comment
early ref.13 time	ch1	word	6C - 6D	
	ch2	∕	6E - 6F	
early ref.13 level	ch1	∕	70 - 71	MSB = phase
	ch2	∕	72 - 73	∕
early ref.14 time	ch1	∕	74 - 75	
	ch2	∕	76 - 77	
early ref.14 level	ch1	∕	78 - 79	MSB = phase
	ch2	∕	7A - 7B	∕
early ref.15 time	ch1	∕	7C - 7D	
	ch2	∕	7E - 7F	
early ref.15 level	ch1	∕	80 - 81	MSB = phase
	ch2	∕	82 - 83	∕
early ref.16 time	ch1	∕	84 - 85	
	ch2	∕	86 - 87	
early ref.16 level	ch1	∕	88 - 89	MSB = phase
	ch2	∕	8A - 8B	∕
early ref.17 time	ch1	∕	8C - 8D	
	ch2	∕	8E - 8F	
early ref.17 level	ch1	∕	90 - 91	MSB = phase
	ch2	∕	92 - 93	∕
early ref.18 time	ch1	∕	94 - 95	
	ch2	∕	96 - 97	
early ref.18 level	ch1	∕	98 - 99	MSB = phase
	ch2	∕	9A - 9B	∕
early ref.19 time	ch1	∕	9C - 9D	
	ch2	∕	9E - 9F	
early ref.19 level	ch1	∕	A0 - A1	MSB = phase
	ch2	∕	A2 - A3	∕
early ref.20 time	ch1	∕	A4 - A5	
	ch2	∕	A6 - A7	
early ref.20 level	ch1	∕	A8 - A9	MSB = phase
	ch2	∕	AA - AB	∕
early ref.21 time	ch1	∕	AC - AD	
	ch2	∕	AE - AF	
early ref.21 level	ch1	∕	B0 - B1	MSB = phase
	ch2	∕	B2 - B3	∕
early ref.22 time	ch1	∕	B4 - B5	
	ch2	∕	B6 - B7	
early ref.22 level	ch1	∕	B8 - B9	MSB = phase
	ch2	∕	BA - BB	∕
early ref.23 time	ch1	∕	BC - BD	
	ch2	∕	BE - BF	
early ref.23 level	ch1	∕	C0 - C1	MSB = phase
	ch2	∕	C2 - C3	∕

name	data composition	
direct level	0 - 1024, 1 step	0 - 100%, 0.0977% step
REV1 output level	∕	∕
direct phase	bit15	0 : normal, 1 : inverse
REV1 output phase	∕	∕
predelay time	1 - 32767, 1 step	1 - 32767words, 1word step
predelay level	0 - 1024, 1 step	0 - 100%, 0.0977% step
early ref.1 - 23 time	1 - 32766, 1 step	1 - 32766words, 1word step
early ref.1 - 23 level	0 - 1024, 1 step	0 - 100%, 0.0977% step
early ref.1 - 23 phase	bit15	0 : normal, 1 : inverse

delay 1 :DL1

name	ch	type	data address	comment
direct level	ch1	word	0 - 1	MSB = phase
	ch2	⌘	2 - 3	⌘
REV1 output level	ch1	⌘	4 - 5	MSB = phase
	ch2	⌘	6 - 7	⌘
tap 1 time	ch1	⌘	8 - 9	
	ch2	⌘	A - B	
tap 1 level	ch1	⌘	C - D	MSB = phase
	ch2	⌘	E - F	⌘
tap 2 time	ch1	⌘	10 - 11	
	ch2	⌘	12 - 13	
tap 2 level	ch1	⌘	14 - 15	MSB = phase
	ch2	⌘	16 - 17	⌘
feedback time		⌘	18 - 19	
feedback level		⌘	1A - 1B	MSB = phase
rotate PEQ freq		byte	1C	
rotate PEQ level		⌘	1D	
rotate PEQ q		⌘	1E	
empty		⌘	1F	
rotate bass freq		⌘	20	
rotate bass level		⌘	21	
rotate treble freq		⌘	22	
rotate treble level		⌘	23	
bass freq	ch1	⌘	24	
	ch2	⌘	25	
bass level	ch1	⌘	26	
	ch2	⌘	27	
treble freq	ch1	⌘	28	
	ch2	⌘	29	
treble level	ch1	⌘	2A	
	ch2	⌘	2B	
dry output level	ch1	word	2C - 2D	MSB = phase
	ch2	⌘	2E - 2F	⌘

name	data composition	
direct level	0 - 1024, 1 step	0 - 100%, 0.0977% step
REV1 output level	"	"
direct phase	bit15	0 : normal, 1 : inverse
REV1 output phase	"	"
tap 1 time	1 - 65516, 1 step	1 - 65516words, 1word step
tap 2 time	"	"
feedback time	"	"
tap 1 level	0 - 1024, 1 step	0 - 100%, 0.0977% step
tap 2 level	"	"
feedback level	"	"
tap 1 phase	bit15	0 : normal, 1 : inverse
tap 2 phase	"	"
feedback phase	"	"
rotate PEQ freq	26 - 65, 1 step (excluding 27,28,31)	200Hz - 18kHz, 1/6oct step (excluding 225Hz,250Hz,355Hz)
rotate PEQ level	0 - 180, 1 step	-12dB - +6dB, 0.1dB step
rotate PEQ q	0 - 6, 1 step	0.267 - 17.31
rotate bass freq	8 - 56, 1 step (excluding 9 and 11)	25Hz - 6.3kHz, 1/6oct step (excluding 28 Hz and 35.5 Hz)
rotate bass level	0 - 180, 1 step	-12dB - +6dB, 0.1dB step
rotate treble freq	20 - 65, 1 step	100Hz - 18kHz, 1/6oct step
rotate treble level	0 - 180, 1 step	-12dB - +6dB, 0.1dB step
bass freq	8 - 56, 1 step (excluding 9 and 11)	25Hz - 6.3kHz, 1/6oct step (excluding 28 Hz and 35.5 Hz)
bass level	0 - 180, 1 step	-12dB - +6dB, 0.1dB step
treble freq	20 - 65, 1 step	100Hz - 18kHz, 1/6oct step
treble level	0 - 180, 1 step	-12dB - +6dB, 0.1dB step
dry output level	0 - 1024, 1 step	0 - 100%, 0.0977% step
dry output phase	bit15	0 : normal, 1 : inverse

delay 2 :DL2

name	ch	type	data address	comment
direct level	ch1	word	0 - 1	MSB = phase
	ch2	⋄	2 - 3	⋄
REV1 output level	ch1	⋄	4 - 5	MSB = phase
	ch2	⋄	6 - 7	⋄
predelay time		⋄	8 - 9	
predelay level		⋄	A - B	MSB = phase
predelay feedback level		⋄	C - D	⋄
predelay RT bass freq		byte	E	
predelay RT bass level		⋄	F	
predelay RT treble freq		⋄	10	
predelay RT treble level		⋄	11	
maindelay in PD level	ch1	word	12 - 13	MSB = phase
	ch2	⋄	14 - 15	⋄
maindelay in dry level	ch1	⋄	16 - 17	MSB = phase
	ch2	⋄	18 - 19	⋄
delay feedback time	ch1	⋄	1A - 1B	
	ch2	⋄	1C - 1D	
delay feedback level	ch1	⋄	1E - 1F	MSB = phase
	ch2	⋄	20 - 21	⋄
delay RT bass freq	ch1	byte	22	
	ch2	⋄	23	
delay RT bass level	ch1	⋄	24	
	ch2	⋄	25	
delay RT treble freq	ch1	⋄	26	
	ch2	⋄	27	
delay RT treble level	ch1	⋄	28	
	ch2	⋄	29	
dry output level	ch1	word	2A - 2B	MSB = phase
	ch2	⋄	2C - 2D	⋄

name	data composition	
direct level	0 - 1024, 1 step	0 - 100%, 0.0977% step
REV1 output level	"	"
direct phase	bit15	0 : normal, 1 : inverse
REV1 output phase	"	"
predelay time	1 - 16375, 1 step	1 - 16375words, 1word step
predelay level	0 - 1024, 1 step	0 - 100%, 0.0977% step
predelay feedback level	"	"
predelay phase	bit15	0 : normal, 1 : inverse
predelay feedback phase	"	"
predelay RT bass freq	8 - 56, 1 step (excluding 9 and 11)	25Hz - 6.3kHz, 1/6oct step (excluding 28 Hz and 35.5 Hz)
predelay RT bass level	0 - 180, 1 step	-12dB - +6dB, 0.1dB step
predelay RT treble freq	20 - 65, 1 step	100Hz - 18kHz, 1/6oct step
predelay RT treble level	0 - 180, 1 step	-12dB - +6dB, 0.1dB step
maindelay in PD level	0 - 1024, 1 step	0 - 100%, 0.0977% step
maindelay in dry level	"	"
delay feedback time	1 - 16379, 1 step	1 - 16379words, 1word step
delay feedback level	0 - 1024, 1 step	0 - 100%, 0.0977% step
delay RT bass freq	8 - 56, 1 step (excluding 9 and 11)	25Hz - 6.3kHz, 1/6oct step (excluding 28 Hz and 35.5 Hz)
delay RT bass level	0 - 180, 1 step	-12dB - +6dB, 0.1dB step
delay RT treble freq	20 - 65, 1 step	100Hz - 18kHz, 1/6oct step
delay RT treble level	0 - 180, 1 step	-12dB - +6dB, 0.1dB step
dry output level	0 - 1024, 1 step	0 - 100%, 0.0977% step
dry output phase	bit15	0 : normal, 1 : inverse



DATE

name	data length	data composition
date	2byte	Year : 7bit Month : 4bit Day : 5bit Example B'1011100011000001; 1011100 0110 00001 ; 1992 June 1

NAME

name	data length	data composition
name	47byte	Basically, ASCII code. 46 characters + end code (00h) 1 byte (Name data cannot be compressed, unlike the D7 model.) Example: Preset memory No. 1 <div style="border: 1px solid black; padding: 2px; display: inline-block; margin: 5px 0;">Brilliant hall</div> db     "     Brilliant hall     " db     "                             ",0

## List of character data

The character data for the DPS series is shown in the following. Refer to the list for creating NAME data. At that time, 0Xh and 7Fh represent a control code and a RAM data, respectively, so do not use them as NAME data. In addition, do not use the data for displaying icon as NAME data.

NSB \ LSB	0001	0010	0011	0100	0101	0110	0111	1000	1001	1010	1011	1100	1101	1110	1111
xxxx0000															
xxxx0001															
xxxx0010															
xxxx0011															
xxxx0100															
xxxx0101															
xxxx0110															
xxxx0111															
xxxx1000															
xxxx1001															
xxxx1010															
xxxx1011															
xxxx1100															
xxxx1101															
xxxx1110															
xxxx1111															

## Data Composition and Data Length of System

### SYSTEM

name	data length	data composition
input mode	1	0 : stereo , 1 : mono
auto help	1	0 : off , 1 : on
load form	1	0 : auto load , 1 : enter load
load time	1	0 - 8 , 1step      200ms - 1000ms , 100ms step
unit(time)	1	0 : word , 1 : msec , 2 : m , 3 : Quarter note , 4 : feet
unit(level)	1	0 : % , 1 : dB
unit(q)	1	0 : q , 1 : oct
remote ch	1	0 - 14 , 1 step      1 - 15 ch , 1ch step
remote bps	1	0 : 9600 , 1 : 19200 , 2 : 31250
empty	1	0 : Set all empty areas to 0 (for expansion).
clock	6	Replace decimal data with hexadecimal one. Example: June 21, 1992 12:34:56 db 92h,06h,21h,12h,34h,56h
user's name	16	Basically, ASCII code End code is 0.
date of birth	2	Example: December 6 db 12,6
key protect	1	0 : off , 1 : on
memory compare	1	0 : edit/memory 1 : edit/parameter 2 : edit/parameter/memory 3 : edit/parameter/block/memory
dial sensitivity	1	0 - 11 , 1 step      1 - 12 , 1 step
empty	11	0 : Set all empty areas to 0 (for expansion).

## Data Composition and Data Length of System MIDI

### SYS.MIDI

name	data length	data composition
MIDI omni	1	0:off,1:on
MIDI ch	1	0 - 15 , 1 step      1 - 16 ch , 1ch step
PGM change no.1	2	0 - 356 , 1 step      0 - 255 : U1 - U256
- memory no.		256 - 355 : P1 - P100
↓	(total 256)	356 : BYPASS
PGM change no.128		
- memory no.		

## Examples of Data

```

CLOCKI equ    B'1011011000110101    ; '91.1.21

PM_EX1:
    db        0,1,0,1                ; REV/HLR, PRE-EF/OFF, POST-EF/SEQ
; LCL.MIDI
    db        125                    ; ctl no.1 : off
    db        125                    ; ctl no.2 : off
    db        125                    ; ctl no.3 : off
    db        125                    ; ctl no.4 : off
    db        6000h                  ; blk/prm no.1 : INPUT - input level sync
    db        7000h                  ; blk/prm no.2 : OUTPUT - output level sync
    db        1042h                  ; blk/prm no.3 : REVS - rotate high
    db        1041h                  ; blk/prm no.4 : REVS - presence control
; INPUT
    dw        1024,1024              ; input level
    dw        0,0                   ; panpot
    dw        0,0                   ; panpot limit min
    dw        1024,1024              ; panpot limit max
; PRE-EF - OFF
; OUTPUT
    dw        1024,1024              ; output level
    dw        0,0                   ; panpot
    dw        0,0                   ; panpot limit min
    dw        1024,1024              ; panpot limit max
; POST-EF - SEQ
    db        1                      ; stereo EQ on/off
    db        0                      ; empty
    db        34,34                  ; bass freq
    db        147,147                ; bass level
    db        52,52                  ; treble freq
    db        143,143                ; treble level
    db        40,40                  ; PEQ freq
    db        120,120                ; PEQ level
    db        2,2                    ; PEQ q
; REVC/REVS - HLR
    dw        0,0                    ; direct level    -> parameter of REVC block
    dw        1024,1024              ; reverb level    -> "
    dw        20                     ; reverb time
    dw        2994,2994              ; predelay 1 time
    dw        512,512               ; predelay 1 level
    dw        1,1                    ; predelay 2 time
    dw        0,0                    ; predelay 2 level
    dw        1,1                    ; cross predelay time
    dw        0,0                    ; cross predelay level
    dw        1847,1847              ; early ref. 1 time
    dw        256,256                ; early ref. 1 level
    dw        2583,2583              ; early ref. 2 time
    dw        512,512               ; early ref. 2 level
    dw        1349,1349              ; 2nd early ref. time
    dw        768,768                ; 2nd early ref. level
    dw        1,1                    ; cross early ref. time
    dw        0,0                    ; cross early ref. level
    dw        256                    ; presence control
    dw        160                    ; rotate high
    db        36                     ; rotate bass freq

```

```

db 126 ; rotate bass level
db 20 ; spread
db 20 ; size

```

```
dw CLOCKI
```

```

db " Brilliant hall "
db " ",0

```

PM\_EX2:

```

db 9,10,0,0; REV2/GTR, REV1/PLR, PRE-EF/OFF, POST-EF/OFF
; LCL.MIDI

```

```

db 125 ; ctl no.1 : off
db 125 ; ctl no.2 : off
db 125 ; ctl no.3 : off
db 125 ; ctl no.4 : off
db 6000h ; blk/prm no.1 : INPUT - input level sync
db 200Fh ; blk/prm no.2 : REV1 - predelay 1 level
db 3003h ; blk/prm no.3 : REV2 - predelay level
db 7000h ; blk/prm no.4 : OUTPUT - output level sync

```

; INPUT

```

dw 1024,1024 ; input level
dw 0,0 ; panpot
dw 0,0 ; panpot limit min
dw 1024,1024 ; panpot limit max

```

; PRE-EF - OFF

; OUTPUT

```

dw 1024,1024 ; output level
dw 0,0 ; panpot
dw 0,0 ; panpot limit min
dw 1024,1024 ; panpot limit max

```

; POST-EF - OFF

; REVC/REV1 - GTR

```

dw 1024,1024 ; reverb level -> parameter of REVC block
dw 0,0 ; send level -> "
dw 5000,5000 ; gate time
dw 0,0 ; envelope form
dw 6000,6000 ; envelope time
dw 10 ; release form
dw 1 ; predelay 1 time
dw 1024 ; predelay 1 level
dw 1 ; predelay 2 time
dw 0 ; predelay 2 level
dw 1,1 ; early ref. time
dw 0,0 ; early ref. level
db 6 ; spread
db 18 ; size

```

; REVC/REV2 - PLR

```

dw 0,0 ; direct level -> parameter of REVC block
dw 1024,1024 ; REV1 output level -> "
dw 20 ; reverb time
dw 1 ; predelay time
dw 1024 ; predelay level
dw 1 ; 2nd predelay time
dw 0 ; 2nd predelay level
dw 1,1 ; early ref. time
dw 0,0 ; early ref. level

```

```
dw 256      ; rotate high
db 18      ; spread
db 18      ; size
dw 0       ; center phase
```

```
dw CLOCKI
```

```
db " REV1 - Gate reverb "
```

```
db " REV2 - Plate reverb ",0
```



4889

M100

# DPS-R7

## **SONY** **SERVICE MANUAL**

*US Model*  
*Canadian Model*  
*AEP Model*  
*UK Model*  
*E model*

### **SUPPLEMENT-2**

File this Supplement with the Service Manual.

**Subject:**

• REMOTE CONTROLLER DATA FORMAT ADDITION

The format for transfer between DPS-R7 and RM-DPS7 dedicated remote controller was added.  
For details, see the DPS-M7 SUPPLEMENT-1 (9-956-852-82).

**Sony Corporation**  
Consumer A&V Products Company  
Home A&V Products Div.

9-956-158-83

English  
95J0204097-1D  
Printed in Japan  
©1995.10  
Published by Home A&V Products Div.  
Quality Engineering Dept.