

# DTC-300ES

## SERVICE MANUAL

AEP Model



Model Name Using Similar Mechanism	DTC-M100
Tape Transport Mechanism Type	DATM-12

### SPECIFICATIONS

Tape	Digital audio tape
Recording head	Rotary head
Recording time	120 minutes (with DT-120)
Tape speed	8.15 mm/s
Drum rotation	Approx. 2,000 rpm
Error correction	Double Read Solomon code

#### Tape

Track pitch	13.6 $\mu$ m (20.4 $\mu$ m)
Sampling frequency	48 kHz, 44.1 kHz, 32 kHz
Modulation system	8 - 10 Modulation
Transfer rate	2.46 Mbit/sec.
Number of channel	2 channels, stereo
D/A conversion	16-bit linear
Frequency response	2-22,000 Hz $\pm$ 0.5 dB
Signal to noise ratio	More than 90 dB
Dynamic range	More than 90 dB
Total harmonic distortion	Less than 0.0085% (1 kHz)
Wow and flutter	Below measurable limit ( $\pm$ 0.001% W.PEAK)

#### Input

	Jack type	Impedance	Rated input level
LINE IN	phono jack	47 kohms	-10 dBs
DIGITAL IN	phono jack	75 ohms	0.5 Vp-p, $\pm$ 20%
DIGITAL IN	optical jack	—	—

#### Output

	Jack type	Impedance	Rated output	Load impedance
LINE OUT	phono jack	470 ohms	-10 dBs	More than 10 kohms
HEAD-PHONES	stereo phone jack	220 ohms	10 mW	32 ohms
DIGITAL OUT	optical jack	—	—	$\lambda$ 660 nm
DIGITAL OUT	phono jack	75 ohms	0.5 Vp-p $\pm$ 20%	—

#### General

Power requirements	220 V AC, 50/60 Hz
Power consumption	35 W
Dimensions	Approx. 470 x 115 x 330 mm (w/h/d) (18 <sup>3</sup> / <sub>8</sub> x 4 <sup>3</sup> / <sub>8</sub> x 12 <sup>7</sup> / <sub>8</sub> inches) incl. side wood, projecting parts and controls
Weight	Approx. 9.0 kg (19 lb 14 oz) incl. side wood

#### Remote commander (supplied)

Remote control system	Infrared control
Power requirements	3 V DC, with two R6 (size AA) batteries
Dimensions	Approx. 67 x 20 x 175 mm(w/h/d) (2 <sup>5</sup> / <sub>8</sub> x 1 <sup>1</sup> / <sub>8</sub> x 6 <sup>7</sup> / <sub>8</sub> inches)
Weight	Approx. 140 g (5 oz) incl. batteries

#### Supplied accessories

Sony batteries SUM-3(NS) (2)  
 Audio connecting cords (2 phono plugs - 2 phono plugs, stereo, for line inputs and outputs) (2)  
 Cleaning cassette (1)

\* The side wood panels on both sides of the deck are detachable. For safety, when removing them, be sure to disconnect the AC power cord from the AC outlet.

Design and specifications subject to change without notice.

DIGITAL AUDIO TAPE DECK  
**SONY**®



TABLE OF CONTENTS

<u>Section</u>	<u>Title</u>	<u>Page</u>	<u>Section</u>	<u>Title</u>	<u>Page</u>
Specifications		1	4-2. Block Diagram		
<b>1. GENERAL</b>			- Audio Section -		21
Location and Function of Controls		2	4-3. Printed Wiring Boards		
			- Servo Section -		26
<b>2. DISASSEMBLY</b>		5	4-4. Schematic Diagram		
			- Servo Section -		31
<b>3. ADJUSTMENTS</b>			4-5. Schematic Diagram		
3-1. Mechanical Adjustments		8	- Audio Section -		35
3-2. Electrical Adjustments		12	4-6. Printed Wiring Boards		
			- Audio Section -		39
<b>4. DIAGRAMS</b>			<b>5. EXPLODED VIEWS</b>		44
4-1. Block Diagram			<b>6. ELECTRICAL PARTS LIST</b>		55
- Servo Section -		18			



SECTION 1  
GENERAL

Location and Function of Controls

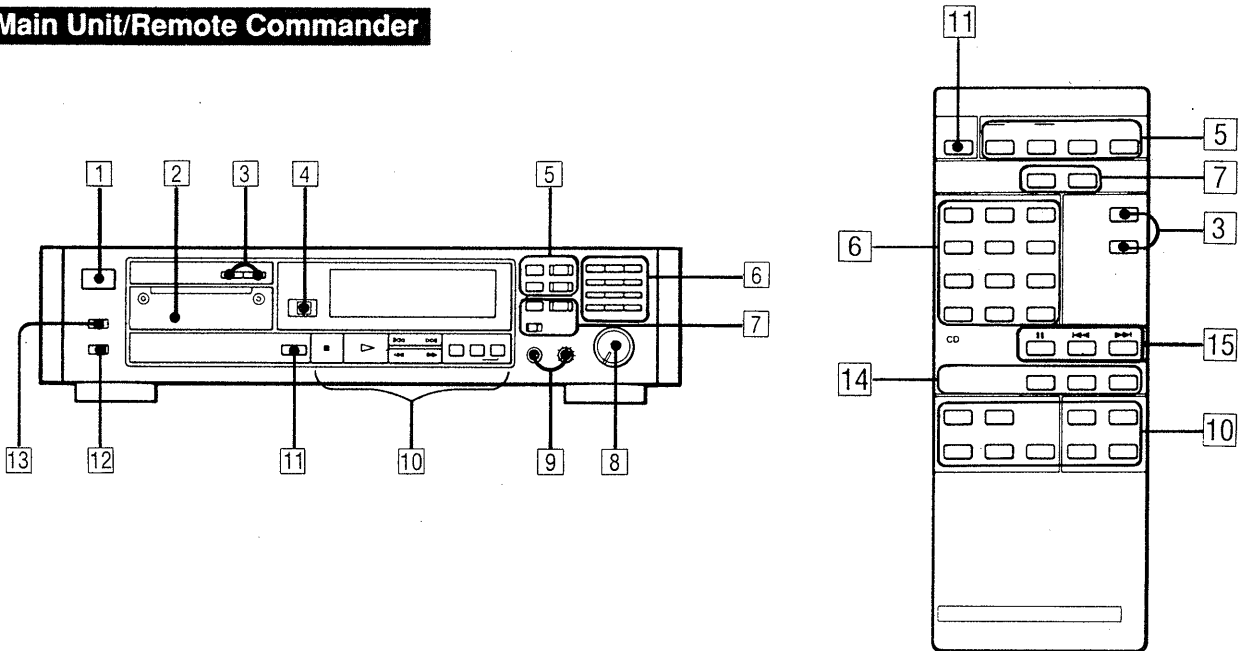
Main Unit/Remote Commander



SAFETY-RELATED COMPONENT WARNING!!

COMPONENTS IDENTIFIED BY MARK  OR DOTTED LINE WITH MARK  ON THE SCHEMATIC DIAGRAMS AND IN THE PARTS LIST ARE CRITICAL TO SAFE OPERATION. REPLACE THESE COMPONENTS WITH SONY PARTS WHOSE PART NUMBERS APPEAR AS SHOWN IN THIS MANUAL OR IN SUPPLEMENTS PUBLISHED BY SONY.

**1 POWER switch**

Turns the power on and off.

**2 Cassette compartment**

Insert a cassette with the window side up and the safety tab facing you.

**3 COUNTER buttons**

**MODE:** Selects the counter indication in the display window among the linear counter (tape running time), absolute time, elapsed time of the selection, and total remaining time of the tape. Each time you press the button, the indication changes sequentially.

**RESET:** Resets the linear counter to "0M 00S".

**4 Remote sensor**

Receives the signal from the remote commander.

**5 START ID buttons**

**AUTO:** Press to turn on the AUTO indicator. When the AUTO indicator is lit, the start ID will automatically be written during recording. When the recording level has been below the fixed level for more than 3 seconds and then returns to the fixed level, the start ID is written on the tape for 9 seconds.

**WRITE (MANUAL on the remote commander):** Press to write the start ID at the desired point during recording or playback. The WRITE indicator lights. The start ID is written on the tape for 9 seconds from the point when the button is pressed.

**ERASE:** Press to erase a start ID. When a start ID and a program number are written on the tape, both codes are simultaneously erased by pressing this button.

**RENUMBER:** Press to renumber the program numbers. When only the start IDs are written, pressing this button will insert program numbers. When this button is pressed, the tape is rewound to the beginning automatically and program numbers are assigned from "1" in numerical order.

**6 Music select buttons**

**Numeric buttons (0-9):** In the record-pause mode, press the desired button to designate the program number you want to write first. Also designate the desired program number to be played back before starting playback by pressing START.

**CLEAR:** Used to cancel the program number which has been entered mistakenly.

**END:** Press to write the end ID on the tape.

**START/MUSIC SCAN:** Press to start playback of the selection designated by the numeric button. In the stop or playback mode, press to listen to the beginning of each selection successively (music scan).

**7 SKIP ID buttons**

**WRITE:** During recording or playback, press at the beginning of the portion you want to skip later. The SKIP ID and WRITE indicators light up for a moment and the skip ID is written for 1 second.

**ERASE:** Press to erase a skip ID which is written at the point just before the current position. The ERASE indicator blinks while the tape is rewound, and lights up while the skip ID is being erased.

**ON/OFF:** Set this button to ON to skip during playback the portion coded with a skip ID code. Set it to OFF to play back the whole tape as it is.

**8 REC LEVEL (recording level) controls**

Adjust the recording level for the analog input signals. The outer knob controls the L (left) channel level and the inner knob the R (right) channel level. The knobs can be turned together. When recording digital signals, the recording level cannot be adjusted.

**9 HEADPHONES jack and LEVEL controls**

The LEVEL controls adjust the headphones volume level.

**10 Tape operation buttons**

■ **(stop):** Press to stop recording or playback.

▶ **(play):** Press to play back the tape.

◀▶ **AMS:** Press to locate the beginning of the selection during playback.

◀▶ **(rewind/review, fast-forward/cue):** In the stop mode, press to rewind/fast-forward the tape. During playback, press to rewind or fast-forward the tape while listening to the sound.

● **REC:** Press ▶ while pressing this button to record.

II **PAUSE:** Press to stop for a moment during playback. To restart playback, press this button again.

If the pause mode continues for about 10 minutes, it will be released automatically and the deck will enter the stop mode.

○ **REC MUTE (record muting):** Inserts a sound-muted portion (space).

**11 ▲ OPEN/CLOSE button**

Press when inserting or removing the cassette.

**12 INPUT selector**

Set in accordance with the signal to be recorded.

**ANALOG:** For recording from the equipment connected to the LINE IN jacks

**DIGITAL:** For recording from the equipment connected to the DIGITAL IN jacks

**13 TIMER switch**

Normally set to OFF. Used to start recording or playback at the desired time using a commercially available audio timer.

**14 CD SYNCHRO (CD synchronized recording) buttons**

**STANDBY:** Press to set the unit in the record-standby mode.

**START:** Press to start recording of the DAT deck and then playback of the CD player.

**STOP:** Press to stop the DAT deck recording and the CD player playback.

**15 CD operation buttons**

Operative only for the Sony CD player equipped with a remote commander.

II **(pause):** Sets the CD player in the pause mode during playback. Press again to release pause. If pressed twice when the player is in the stop mode, playback starts.

◀▶ **(AMS):** Press to locate the desired selection on the Compact Disc during playback or in the stop mode.

## Rear Panel Jacks

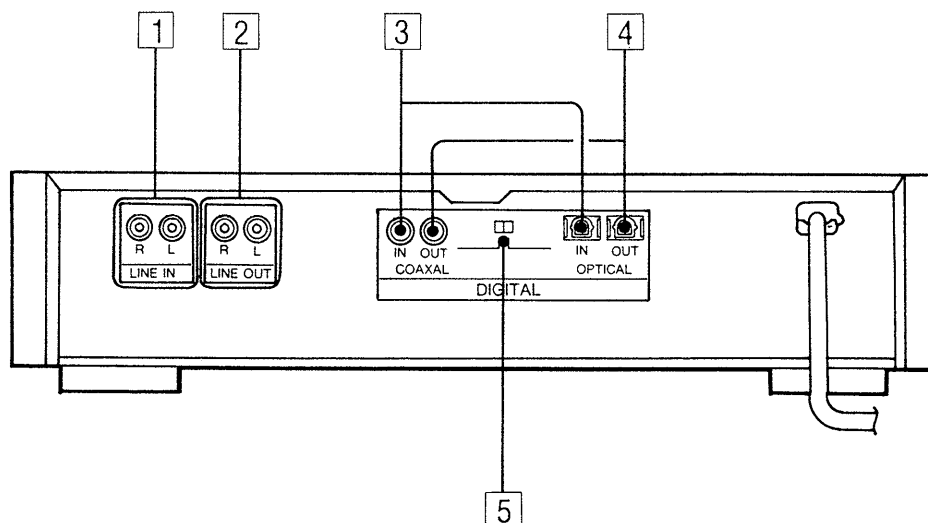
**1 LINE IN (line input) jacks (phono jack)**

Connect to the recording outputs of an amplifier. The signal from the source equipment connected to the amplifier is supplied to this deck, and can be recorded with the sampling frequency of 48kHz.

**2 LINE OUT (line output) jacks (phono jack)**

Connect to the DAT or tape inputs of an amplifier. The playback signal of this deck will be output.

**3 COAXIAL/OPTICAL DIGITAL IN (digital input) jacks (phono jack/optical jack)**

The digital signal from another DAT deck or other digital source, such as a BS tuner having digital outputs, is input for digital recording. If PROH (copy prohibition) is displayed, however, digital recording of the source signal is not possible.

If the sampling frequency of the source signal is 44.1kHz, digital recording is not possible.

**4 COAXIAL/OPTICAL DIGITAL OUT (digital output) jacks (phono jack/optical jack)**

The digital signal reproduced by this deck is output without passing by the D/A converter of the deck. Connect to the digital input of another DAT deck to perform digital-to-digital dubbing.

**5 DIGITAL INPUT SELECTOR**

Selects digital input signal.

**COAXIAL:** Selects the equipment connected to the COAXIAL IN jack.

**OPTICAL:** Selects the equipment connected to the OPTICAL IN jack.



## SECTION 2 DISASSEMBLY

NOTE: Follow the disassembly procedure in the numerical order given.

- ① Remove the four M4S tight screws (with ring).
- ② Remove an M3 × 8 screw (case).
- ③ Remove the case.

### DATM BLOCK ASSY

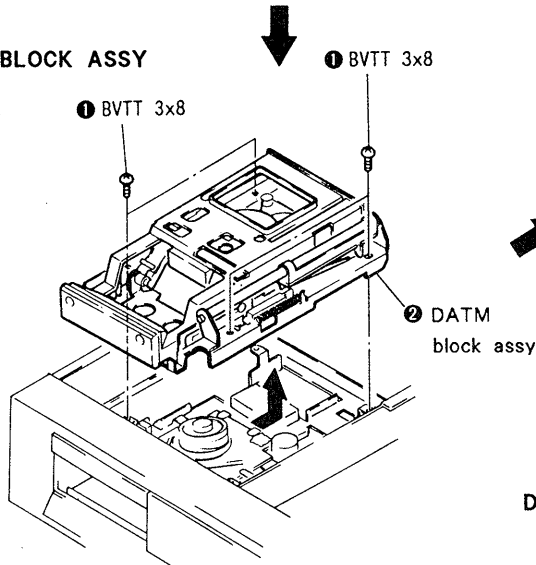

### MOTOR

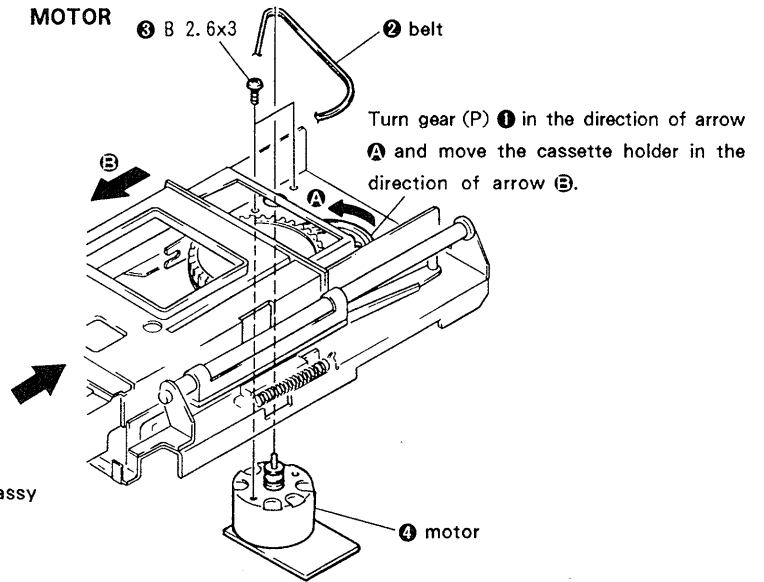

### MECHANISM DECK ASSY

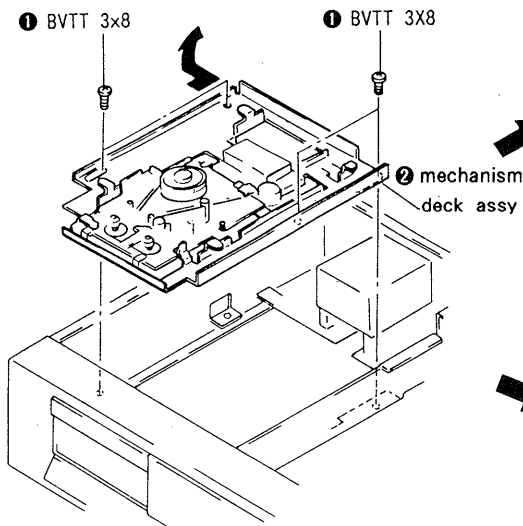

### DC MOTOR

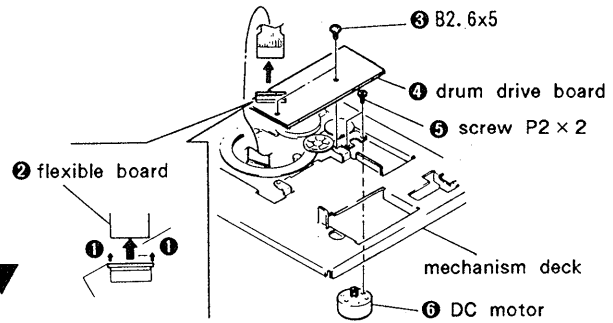

### MECHANISM DECK

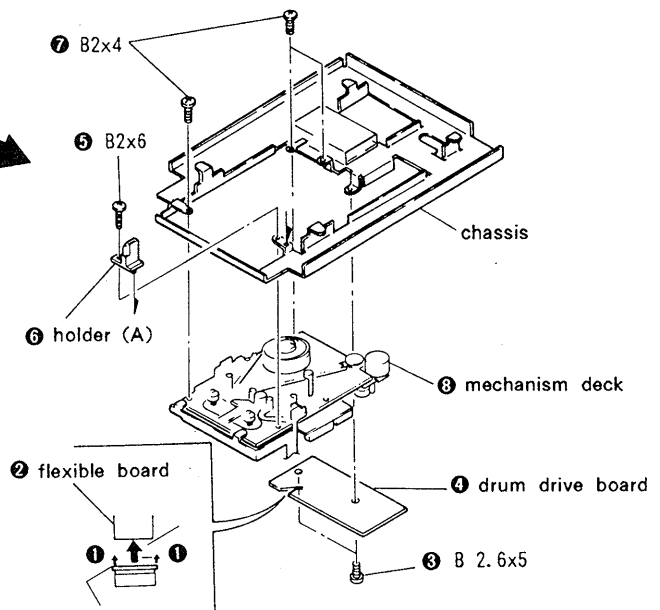

**DTC-300ES Test Mode**

For DTC-300ES, the internal CPU modes can be displayed for servicing on the counter's six-segment display.

(a) The following modes can be displayed:

- . Mechanical operation  
(Mechanical microcomputer operation)
- . Mechanical instruction  
(Main microcomputer instruction)
- . Operation/operation completion
- . End sensor normal/abnormal
- . Cassette half existence
- . OPEN/CLOSE
- . Tape end (take-up)/normal
- . Tape end (supply)/normal
- . A/B head RF existence
- . WIDTH 1.5 times normal speed/NOT 1.5 times normal speed
- . Soft tape/normal tape
- . REC inhibit/OK
- . Drum normal/abnormal
- . Tray in/out
- . TEST mode/NOT TEST mode
- . Take-up end hold/NOT hold
- . Tray loading normal/abnormal
- . Position EJECT/NOT EJECT

(b) To display the test modes, set the TIMER switch to TIME PLAY and turn on the power switch while pressing the START ID WRITE and SKIP ID WRITE buttons. The mechanical microcomputer then enters the test mode. When the MODE switch is pressed, the modes are changed as follows :

ABS TIME → PGM TIME → REMAINING →  
REMAINING (Mechanical operation display model)  
→ Linear counter → ABS TIME

(c) The indicator display is described below.

Using indicators ① through ⑥, data in the main microcomputer is displayed by four bits (hexadecimal).

(Items ①, ③, ④, ⑤, and ⑥ are mechanical microcomputer data and ② is main microcomputer data.)

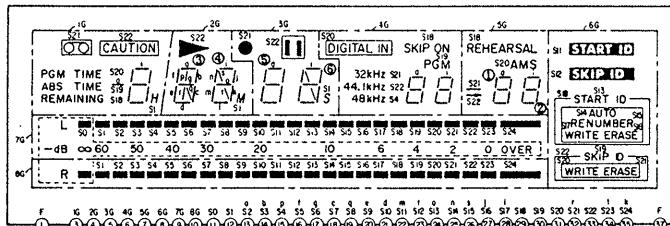

Display position	Description
①	Mechanical operation
②	Mechanical instruction (main microcomputer to mechanical microcomputer)
③	0 Operation mode (OPERATION/COMPLETION)
	1 End sensor (NORMAL/ABNORMAL)
	2 Cassette half (YES/NO)
	3 OPEN (OPEN/CLOSE)
④	0 Tape end take-up reel (TOP/NOR)
	1 Tape end supply reel (END/NOR)
	2 RF (NO RF/RF)
	3 WIDTH (1.5 TIMES NORMAL SPEED/NOT 1.5 TIMES NORMAL SPEED)
⑤	0 Tape (SOFT/NORMAL)
	1 REC (INHIBIT/OK)
	2 DRMERR (DRUM NORMAL/ABNORMAL)
	3 T OUT (TRAY IN/OUT)
⑥	0 FTEST (TEST MODE/NOT TEST MODE)
	1 TEUDH (TAKE-UP END HOLD/NOT HOLD)
	2 TLBF (TRAY LOADING NORMAL/ABNORMAL)
	3 PEJCT (EJECT POSITION/NOT EJECT POSITION)

- (d) Display positions ① and ② are shown below.  
 (The same data as in ② is displayed in ① at all times with a slight delay.)

Code	Display	Description
0	0	FWD x 1
1	1	FWD x 2.5
2	2	FWD x 16
3	3	REC FWD
4	4	FF
5	5	FF SEARCH
6	6	FWD x 16 (measure)
7	7	OPEN/CLOSE
8	8	STOP
9	9	PAUSE
A	-	REV x 16 (measure)
B	b	REW
C	c	REW SEARCH
D	d	REV x 1
E	e	REV x 2.5
F	Blank	REV x 16

- (e) Operations in the TEST mode are described below (as compared with those in the normal mode).

- 1) Cassette is not detected.
- 2) CAUTION indication does not appear.

1. Make adjustments in the order of the steps described.
2. Use the alignment tapes described below.  
 TY-7111 (8-909-812-00)  
 TY-7252 (8-909-822-00)  
 TY-7551 (8-909-814-00)  
 TY-30B (8-892-358-00)

Use the torque meters described below.

- TW-7131 (8-909-708-71)  
 TW-7231 (8-909-708-72)

3. Initial settings are as follows :

TIMER	OFF
SKIP	OFF
INPUT selection	DIGITAL
REC level	MIN
HEADPHONE level	MIN
COUNTER mode	AUTO

4. Set the tape path adjustment mode as described below.  
 The DTC-300ES cannot enter the tape path adjustment mode from PLAY mode. When the AMS button (▶▶) is pressed using a 1.5 times normal speed tape, the FS (sampling frequency) indication changes to 32kHz and the set enters the FWD mode. When the AMS button (◀◀) is pressed, it enters the REV mode. When the former button is pressed using a normal speed tape, the set enters the FWD × 16 mode. When the latter button is pressed, it enters the REV × 16 mode.

## SECTION 3 ADJUSTMENTS

### 3-1. MECHANICAL ADJUSTMENT

When replacing the drum, finely adjust the tape path (in 1.5 times normal speed FWD mode).

#### 3-1-1. Tape Path Fine-Adjustment (×1.5 FWD Mode)

##### Adjustment

1. Connect CH-1 of an oscilloscope to pin (A) of an offset jig and CH-2 to pin (B) of the offset jig.
2. Connect a 3.3k-ohm resistor between pins 7 (GAIN 2) and 6 (GAIN 1) of IC525.
3. Connect the offset jig as shown below.

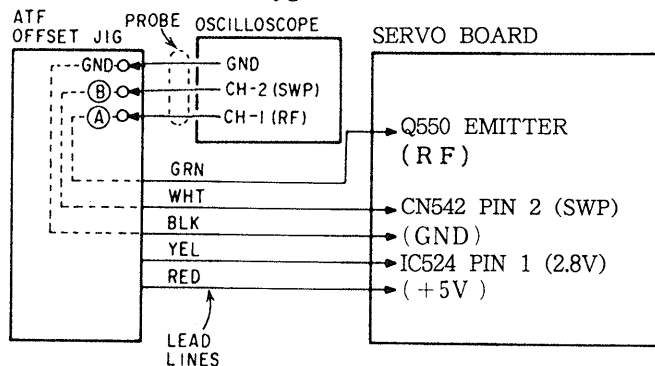

4. Turn on the power switch, insert alignment tape TY-7251, and put the set into the TEST mode.
5. Press the AMS (▶▶) button.
6. Remove the YEL and RED leads of the offset jig and adjust guides S1 and T1 so that the shape of the RF signal waveform on the oscilloscope is close to a square.
7. Connect the YEL and RED leads of the offset jig, turn the offset jig's volume control, and fix the RF signal waveform to a half level. At that time, finely adjust guides S1 and T1 again so that the shape of the waveform is close to a square.
8. Turn the offset jig's volume control, slowly change the RF signal waveform in the vertical direction, and check that the waveform uniformly changes in the horizontal direction.
9. Remove the two leads (YEL and RED) of the jig from CNT51.
  - (1) Check that peak value (B) of the RF signal waveform is 60mV or more.
  - (2) Check that the undershoot level of the RF signal waveform's flat portion is within 10%.
10. If the specification is not satisfied, repeat Steps 3 through 9.
11. Check that there is no gap between the tape and lower flange in guides S2, T2, T3, and F. Check that no curl occurs when the tape touches the lower flange. If there is a gap or a curl occurs, adjust each guide according to the adjustment on the next page.

Adjustment Location :

Mechanical guides S1 and T1

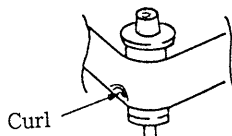
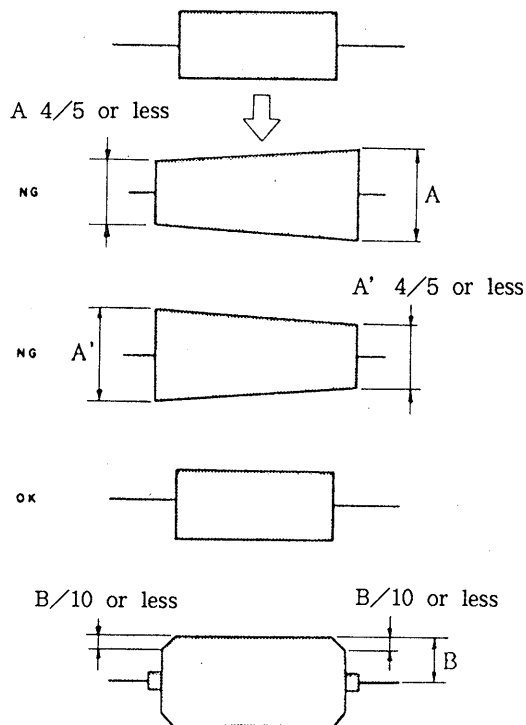
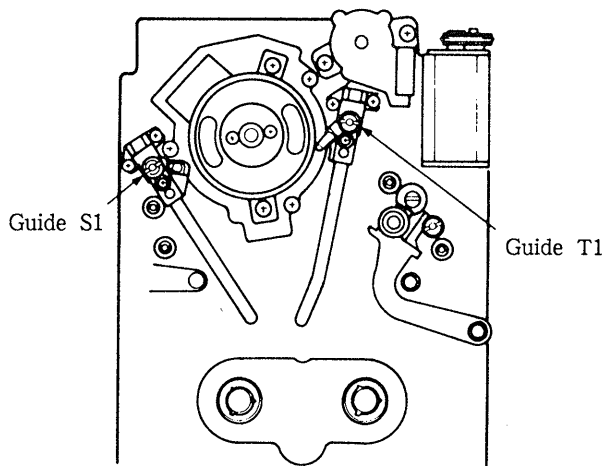

\* The curl indicates the distortion which occurs on the tape in the FWD mode. When light is shone on the tape, the curl can be viewed more visually.

### 3-1-2. T2 Guide Adjustment

#### Adjustment

1. Connect CH-1 of an oscilloscope to pin 5 (RF) of CN542 on the servo board and CH-2 to pin 2 (SWP) of CN542.
2. Turn on the power switch, insert alignment tape TY-7252 (8-909-822-00), and put the set into the TEST mode. Press the AMS button, then press the PLAY (▶) button.
3. Raise guide T1 so that the RF signal waveform is as shown below.

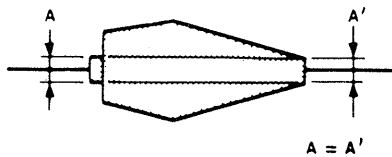

4. Raise guide T2 and align it with the lower edge of the tape.
5. Lower guide T1 so that the RF signal waveform is normal.
6. Replace the alignment tape by DT-120R and check that the tape is aligned with the lower edge of guide T3 at the beginning of it. If it is not, repeat Step 4.

#### Adjustment Location :

Mechanism assembly

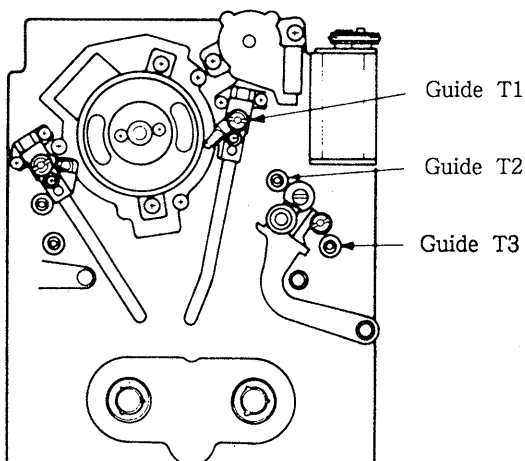

### 3-1-3. S2 Guide Adjustment

#### Adjustment :

1. Turn on the power switch, insert blank tape TY-30B (8-892-358-00), and put the set into the PLAY (▶) mode.
2. Raise guide S2 and align it with the lower edge of the tape.

Note : Check that no tape curl occurs at guide S2 in the REW (▶▶) mode.

#### Adjustment Location :

Mechanism assembly

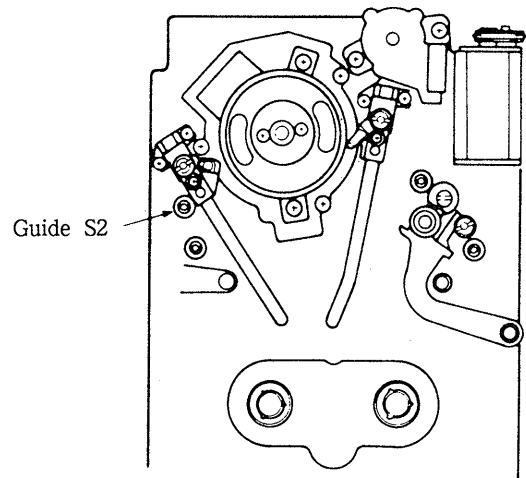

**3-1-4. F Guide Adjustment**

Adjustment :

1. Turn on the power switch, insert blank tape TY-30B (8-892-358-00), and put the set into the PLAY (▶) mode.
2. Align guide F with the lower edge of the tape.

Note : Check that the tape is aligned with the lower edge of guide T3 without curl.

Adjustment Location :

Mechanism assembly

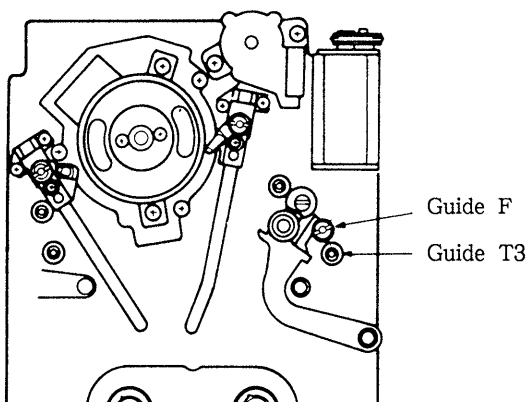

**3-1-6. T3 Guide Adjustment**

Adjustment :

1. Turn on the power switch, insert blank tape TY-30B (8-892-358-00), and put the set into the PLAY (▶) mode.
2. Align guide T3 with the lower edge of the tape.

Note : Check that the tape is aligned with the lower edge of guide T3 without curl.

Adjustment Location :

Mechanism assembly

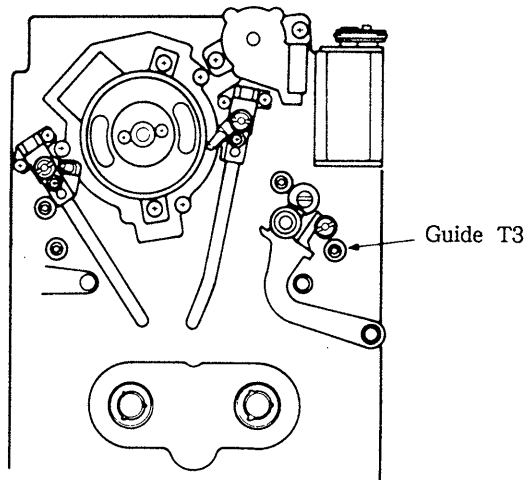

**3-1-5. S3 Guide Adjustment**

Adjustment :

1. Turn on the power switch, insert blank tape TY-30B (8-892-358-00), and put the set into the PLAY (▶) mode.
2. Align guide S3 with the lower edge of the tape.

Note : Check that the tape is aligned with the lower edge of guide S3 without curl.

Adjustment Location :

Mechanism assembly

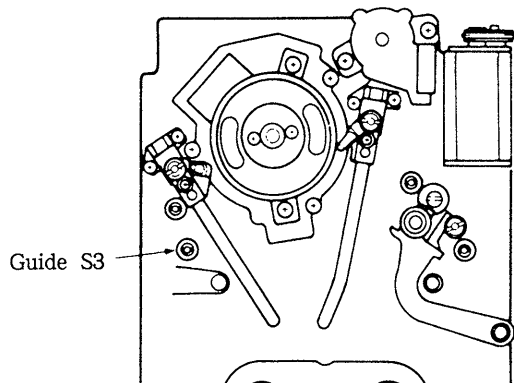

**3-1-7. Rotary Encoder Adjustment**

Adjustment :

1. Remove the rotary encoder.
2. Turn the gear at the back of the chassis shown in Fig. A in the direction indicated by the arrow until the capstan axis housing touches the pinch roller as shown in Fig. B.
3. At that time, align the line in the rotary encoder's gear with mark and tentatively fasten the rotary encoder (see Fig. C).
4. Put the set into the TEST mode.
5. Alternately repeat the PLAY (▶) and STOP (■) modes and check that the pinch roller is pressed against the capstan axis in the PLAY (▶) mode and that the capstan axis housing touches the pinch roller as shown in Fig. B in the STOP (■) mode. Then, tighten the screws.
6. If Step 5 is not satisfied, repeat Steps 1 through 5.

Adjustment Location :  
Mechanism assembly

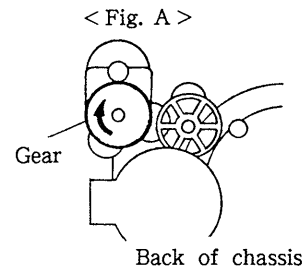
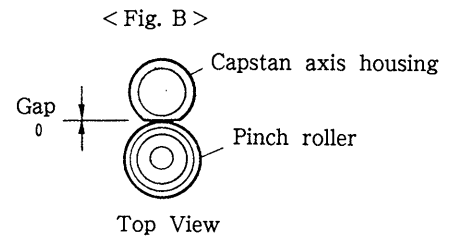
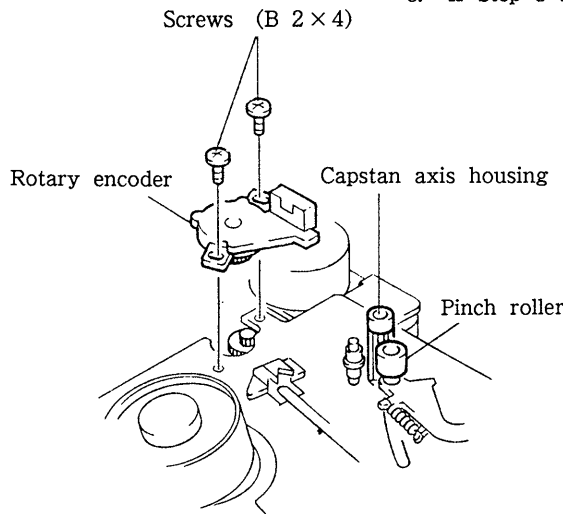
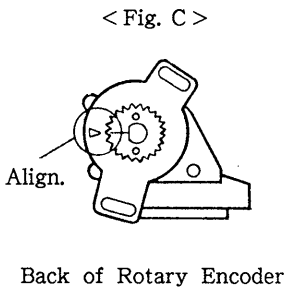

**3-1-8. Loading Ring Installation**

1. Combine the loading ring (R) assembly and loading ring (L) assembly with the portion crossed as shown in the figure.
2. Insert into two ring rollers A.
3. Tighten the two screws while pushing the ring roller assembly in the direction indicated by the arrow so that ring roller B is aligned with the loading ring.
4. Slowly turn the loading ring and check that there is no play.
5. Insert the two loading arms into the axes and fix them using washers.

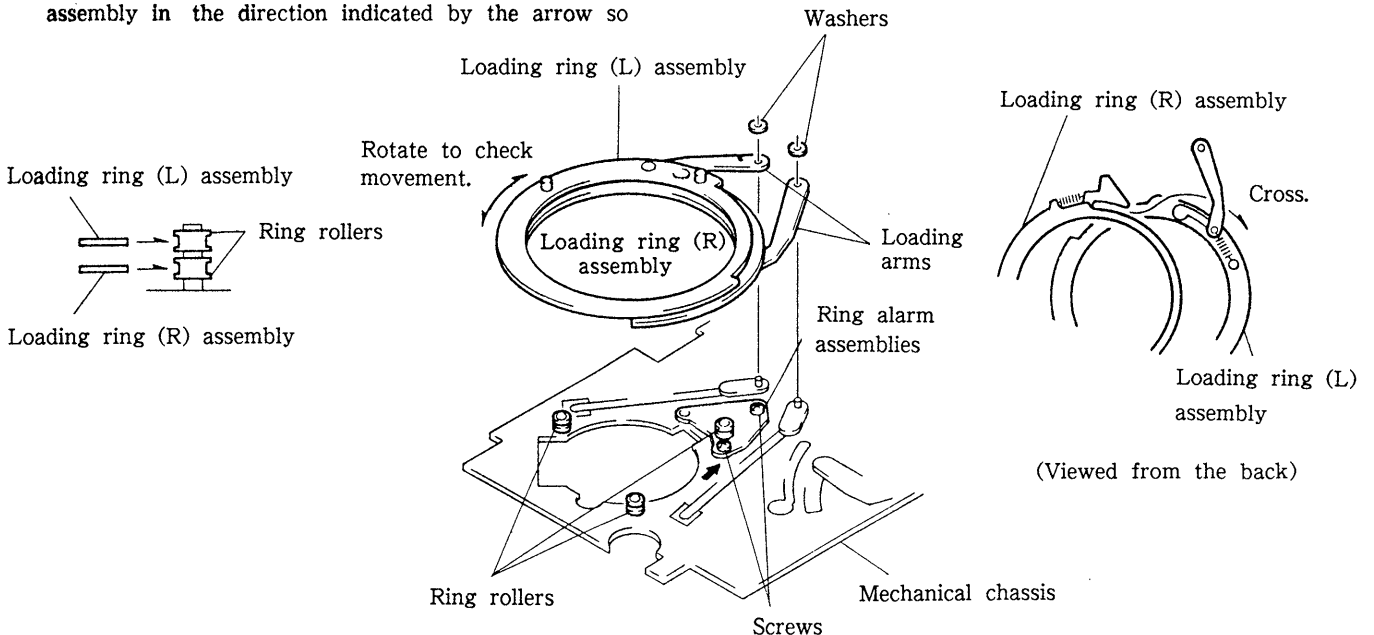

### 3-2. ELECTRICAL ADJUSTMENT

Adjustment Location :  
 Servo board (soldering side)

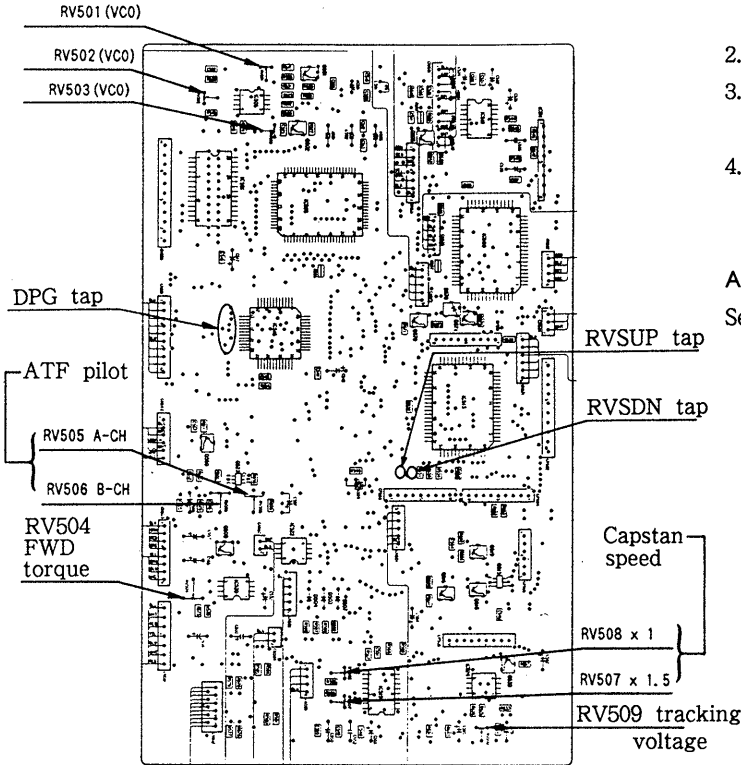

#### 3-2-1. FWD Torque Adjustment

- Adjustment :
1. Turn on the power switch and insert FWD torque meter TW-7131.
  2. Put the set into the PLAY (▶) mode.
  3. Adjust RV504 so that the FWD torque value (take-up rewinding torque) is 10 to 13g cm.
  4. Check the torque meter reading while it makes one cycle.

Adjustment Location :  
 Servo board (soldering side)

AD board (component side)

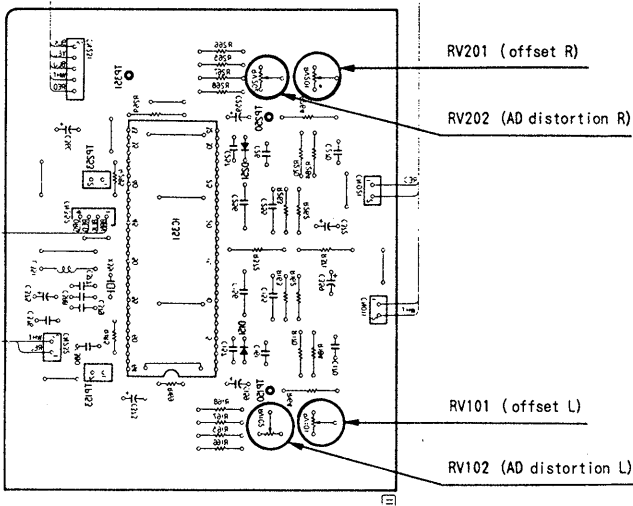

#### 3-2-2. FWD Back Tension Adjustment

- Procedure :
1. Turn on the power switch and insert FWD torque meter TW-7131.
  2. Put the set into the FWD (▶) mode.
  3. Check that the back tension (at supply side) is 4.5 to 6.5g cm.
  4. Check the torque meter reading while it makes a half cycle.



### 3-2-3. REVIEW Torque Check

#### Procedure :

1. Turn on the power switch and insert FWD torque meter TW-7131.
2. Put the set into the TEST mode.
3. Put the set into the REVIEW (▶ + ◀) mode.  
(Press the REW (◀) button continuously in the FWD mode.)
4. Check that the rewinding torque at the supply side is 15 to 18g cm.
5. If the torque value does not satisfy the specification, short the tap of RVSUP or RVSDN and recheck.
6. After check, cancel the TEST mode.

#### Check Point :

Servo board (soldering side)

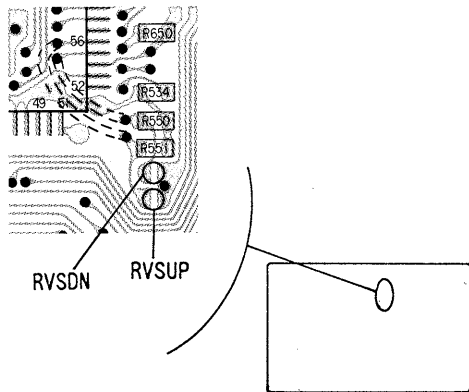

### 3-2-4. FF/REW Torque Check

#### Procedure :

1. Turn on the power switch and insert FF/REW torque meter TW-7231.
2. Put the set into the TEST mode.
3. Put the set into the FF (▶▶) and REW (◀◀) modes and check that the torque value is 30 to 45g cm or more.
4. After check, cancel the TEST mode.

### 3-2-5. Tracking Voltage Adjustment

#### Adjustment :

1. Connect a digital tester between pin 6 of IC525 and GND.
2. Turn on the power switch, insert blank tape TY-30B, and put the set into the STOP (■) mode.
3. Adjust RV509 so that the tester reading is  $2.9V + 5mV$ .

Note : When performing the tracking voltage adjustment, be sure to adjust the capstan speed at  $\times 1$  and  $\times 1.5$ .

#### Adjustment Location :

Servo board (soldering side)

### 3-2-6. Capstan Speed Adjustment ( $\times 1$ )

#### Adjustment :

1. Connect a frequency counter to pin 7 (CFG) of IC516.
2. Turn on the power switch, insert blank tape TY-30B, and put the set into the PLAY (▶) mode.
3. Adjust RV508 so that the frequency counter reading is  $674 \pm 1Hz$ .

Note : When performing the capstan speed adjustment ( $\times 1$ ), be sure to adjust the capstan speed at ( $\times 1.5$ ).

#### Adjustment Location :

Servo board (soldering side)

3-2-7. Capstan Speed Adjustment (×1.5)

Adjustment :

1. Connect a frequency counter to pin 7 (CFG) of IC516.
2. Turn on the power switch, insert blank tape TY-30B (for 1.5 times normal speed), and put the set into the PLAY (▶) mode.
3. Adjust RV507 so that the frequency counter reading is  $1011 \pm 2\text{Hz}$ .

Note : When the recognition hole of blank tape TY-30B is opened, the set is put into the 1.5 times normal speed mode. When the hole is blocked using an adhesive tape, the mode is changed from 1.5 times normal speed to normal speed.

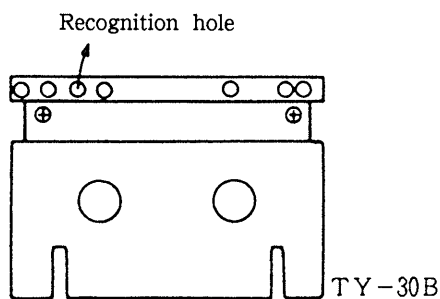

Adjustment Location :

Servo board (soldering side)

3-2-8. Capstan Speed Check (×2.5)

Procedure :

1. Connect a frequency counter to pin 7 (CFG) of IC516.
2. Turn on the power switch, insert blank tape TY-30B, and put the set into the CUE (▶ + ►►) mode. (Press the FF (►►) button continuously in the PLAY mode.)
3. Check that the frequency counter reading is  $1685 \pm 150\text{Hz}$ .

3-2-9. Capstan Speed Check (×16)

Procedure :

1. Connect an oscilloscope to pin 3 (PCOT) of IC518.
2. Put the set into the TEST mode.
3. Turn on the power switch, insert blank tape TY-30B, and put the set into the PLAY PAUSE (▶ + ||) mode. Then, continuously press the FF (►►) or REW (◄◄) button.
4. Check that the signal waveform on the oscilloscope is as shown below.

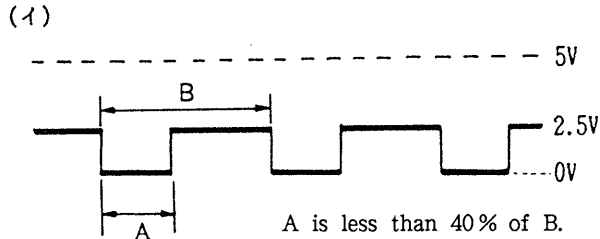
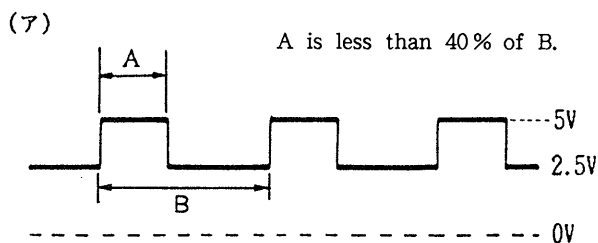

### 3-2-9. DPG Adjustment

#### Adjustment :

1. Connect CH-1 of an oscilloscope to the emitter pin (RF) of Q550 and CH-2 to pin 20 (DPG) of IC515.
2. Select tap pattern 8 and make a solder bridge to check the original delay value of a PG pulse. (The delay time of one DPG SW code is approximately 100  $\mu$  sec.)
3. Turn on the power switch, insert alignment tape TY-7251, and put the set into the TEST mode.
4. Press the AMS button, then press the PLAY (▶) button.
5. Select the tap pattern so that the trailing edges of a DPG pulse and RF signal's non-signal are approximately 650  $\mu$  sec.  
(Coarse adjustment)  
High-order 4 bits (taps 4, 5, 6, and 7)
6. Put the set into the PLAY (▶) mode and select the tap pattern so that the DPG and RF signals on the oscilloscope are 650  $\pm$  15  $\mu$  sec. Then, finely adjust the DPG pulse width.  
Low-order bits (taps 0, 1, 2, and 3)

Note : When replacing the drum related block, be sure to perform the DPG adjustment.

#### Servo board (soldering side)

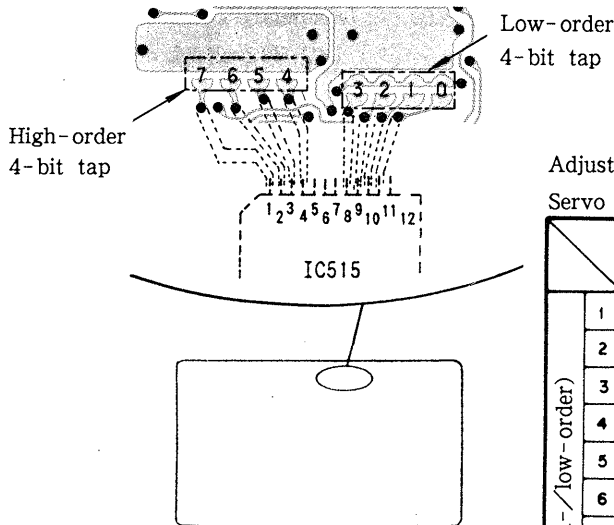

(Reference)

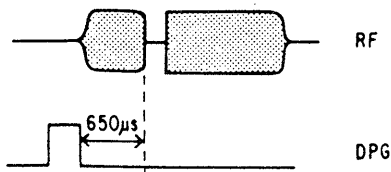

### 3-2-10. ATF Pilot Adjustment

#### Adjustment :

1. Connect CH-1 of an oscilloscope to pin 8 (S/H3) of IC523.  
Connect CH-2 of an oscilloscope to pin 2 (SWP) of CN542.  
(TRIGGER)
2. Turn on the power switch, insert alignment tape TY-7111, and put the set into the STOP (■) mode. Then, put the set into the TEST mode.
3. Align the luminescent spot on the oscilloscope with the scale center position. (Never align the spot with the center position when the input is set to GND.)
4. Put the set into the PLAY (▶) mode and adjust RV505 (A-CH) and RV506 (B-CH) so that the signal waveform is 600mV after two or three seconds.

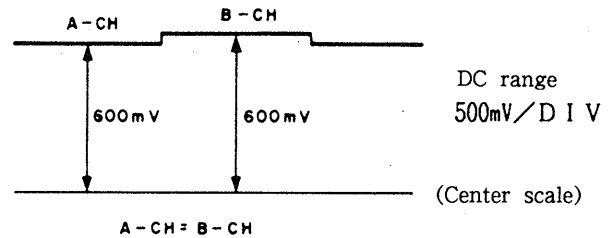

Note : If the signal waveform deflects vertically, adjust it in the deflection center.

#### Adjustment Location :

Servo board (soldering side)

#### Adjustment Point

Servo board (soldering side)

	Tap pattern			
	0/4	1/5	2/6	3/7
1	○			
2		○		
3	○	○		
4			○	
5	○		○	
6		○	○	
7	○	○	○	
8				○
9	○			○
A		○		○
B	○	○		○
C			○	○
D	○		○	○
E		○	○	○
F	○	○	○	○

### 3-2-11. VCO Adjustment

#### Adjustment :

1. Unsolder tap pattern (A) on the main board and open it.
2. Connect CH-1 of an oscilloscope to TP501 and CH-2 to TP502.  
(Connect the trigger of the oscilloscope to SWP (pin 2 of CN542).)

3. Turn on the power switch, insert a music tape, put the set into the TEST mode, and put it into the PLAY mode. (Any music tape can be used.)
4. Adjust RV503 so that the DC potential difference at TP502 is approximately  $-2.0V$ .
5. Adjust RV502 so that the signal waveform at TP501 satisfies the specification.

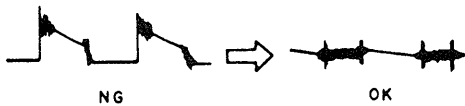

6. Adjust RV501 so that the signal waveform at TP501 satisfies the specification.

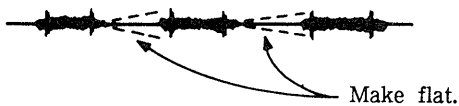

7. Put the set into the CUE mode and finely adjust RV502 so that the signal waveform at TP501 satisfies the specification. (The specified waveform is the same as in Step 6.)
8. Put the set into the REVIEW mode and finely adjust RV501 so that the signal waveform at TP501 satisfies the specification. (The specified waveform is the same as in Step 6.)
9. Alternate putting the set into the CUE and REVIEW modes two or three times and check that the signal waveform at TP501 satisfies the specification. (The specified waveform is the same as in Step 6.)
10. Turn off the power switch and solder-bridge the tap pattern.
11. Turn on the power switch and put the set into the PLAY (▶) mode again.
12. Readjust RV503 so that the signal waveform at TP501 satisfies the specification. (The specified waveform is the same as in Step 6.)

13. Put the set into the CUE mode and finely adjust RV503 so that the signal waveform at TP501 satisfies the specification.



14. Put the set into the REVIEW mode and check that the signal waveform at TP501 satisfies the specification.

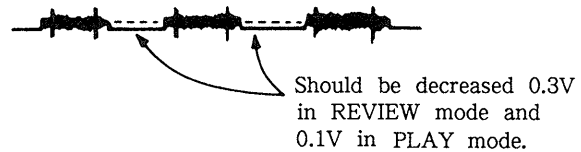

15. Put the set into the PLAY mode and check the signal waveform at TP501. (The specified waveform is the same as in Step 6.)

16. Put the set into the FF AMS and REW AMS modes and check the signal waveforms at TP501 and TP502 (in the 16 times normal speed mode).



17. Set the TEST mode to OFF, put the set into the FF AMS and REW AMS modes, and check the signal waveforms at TP501 and TP502 (in the AMS mode).

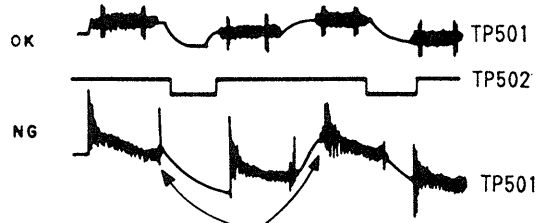

Voltages deflect significantly in the positive (+) direction.

Servo board (Soldering side)

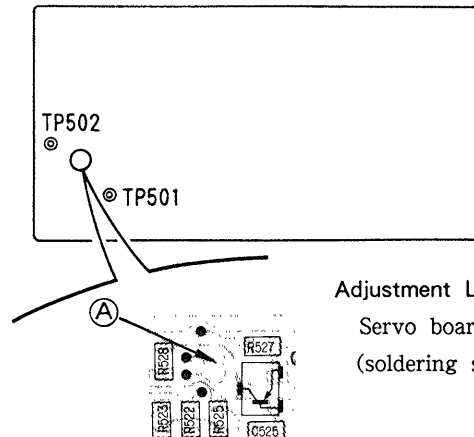

Adjustment Location :  
Servo board  
(soldering side)

3-2-12. AD DC Offset Distortion Factor Adjustment

Adjustment :

1. Set the INPUT select switch to ANALOG and input a 1kHz (0dB) signal.
  2. Connect an oscilloscope to the LINE OUT terminal, TP150 (L-CH), and TP250 (R-CH).
  3. Turn on the power switch and insert blank tape TY-30B.
  4. Put the set into the REC mode.
  5. Turn the REC volume control until the OVER indicator blinks and adjust RV101 (L-CH) and RV201 (R-CH) so that the LINE OUT signal waveform is uniformly clipped in the vertical direction.
  6. Attenuate the input signal and fully turn RV102 (L-CH) and RV202 (R-CH) counterclockwise so that the signal waveforms (integrated waveforms) at TP150 (L-CH) and TP250 (R-CH) are as shown in Fig. (C). After that, gradually turn them clockwise until the signal waveforms shown in Fig. (E) are obtained.
  7. Repeat Step 5.
  8. Turn the REC volume control so that the signal waveform is as shown in Fig. (E) when the level meter reading is approximately -55. Then, slightly turn RV102 and RV202 clockwise so that the signal waveform is as shown in Fig. (F).
- Distortion factor (reference) : -80.5dB or less (1kHz full-scale, 20kHz LPF ON)

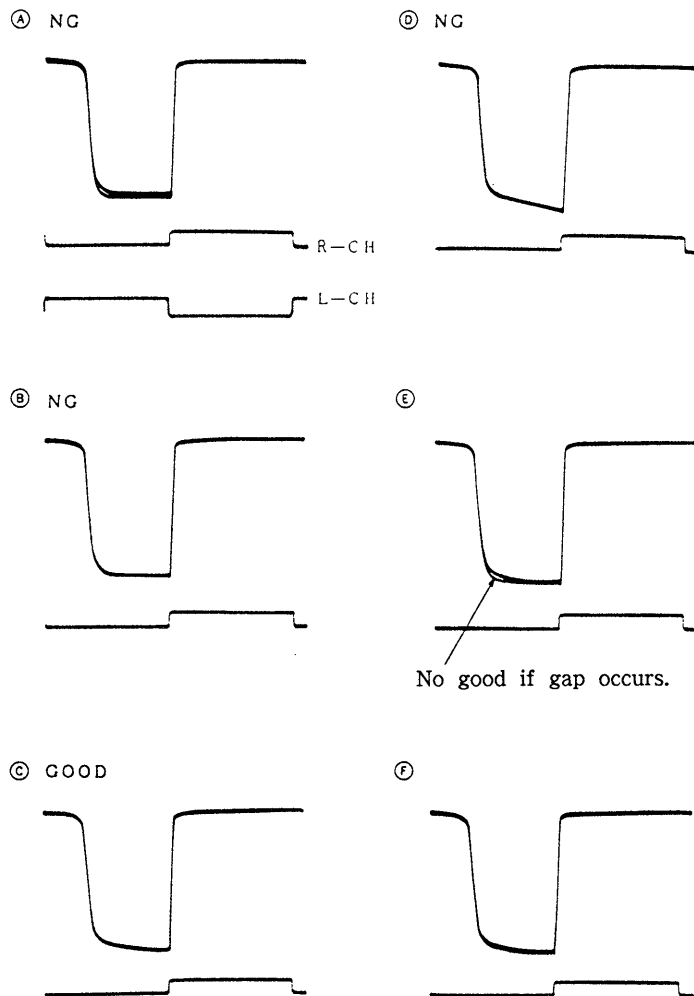

Adjustment Location :

AD board (component side).

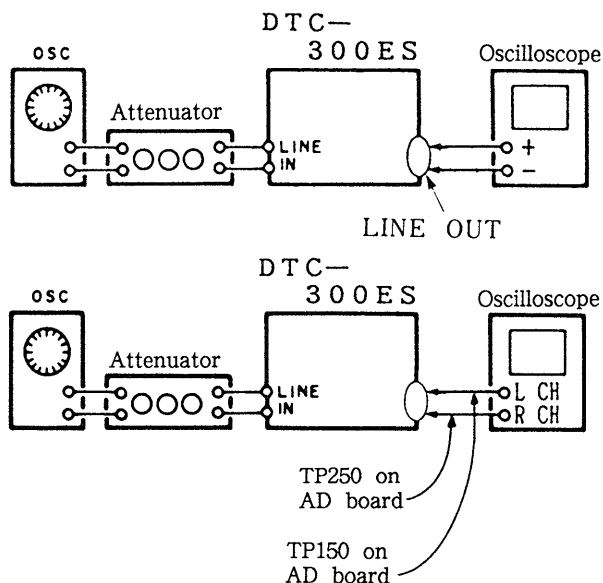

SECTION 4 DIAGRAMS

4-1. BLOCK DIAGRAM—SERVO SECTION—

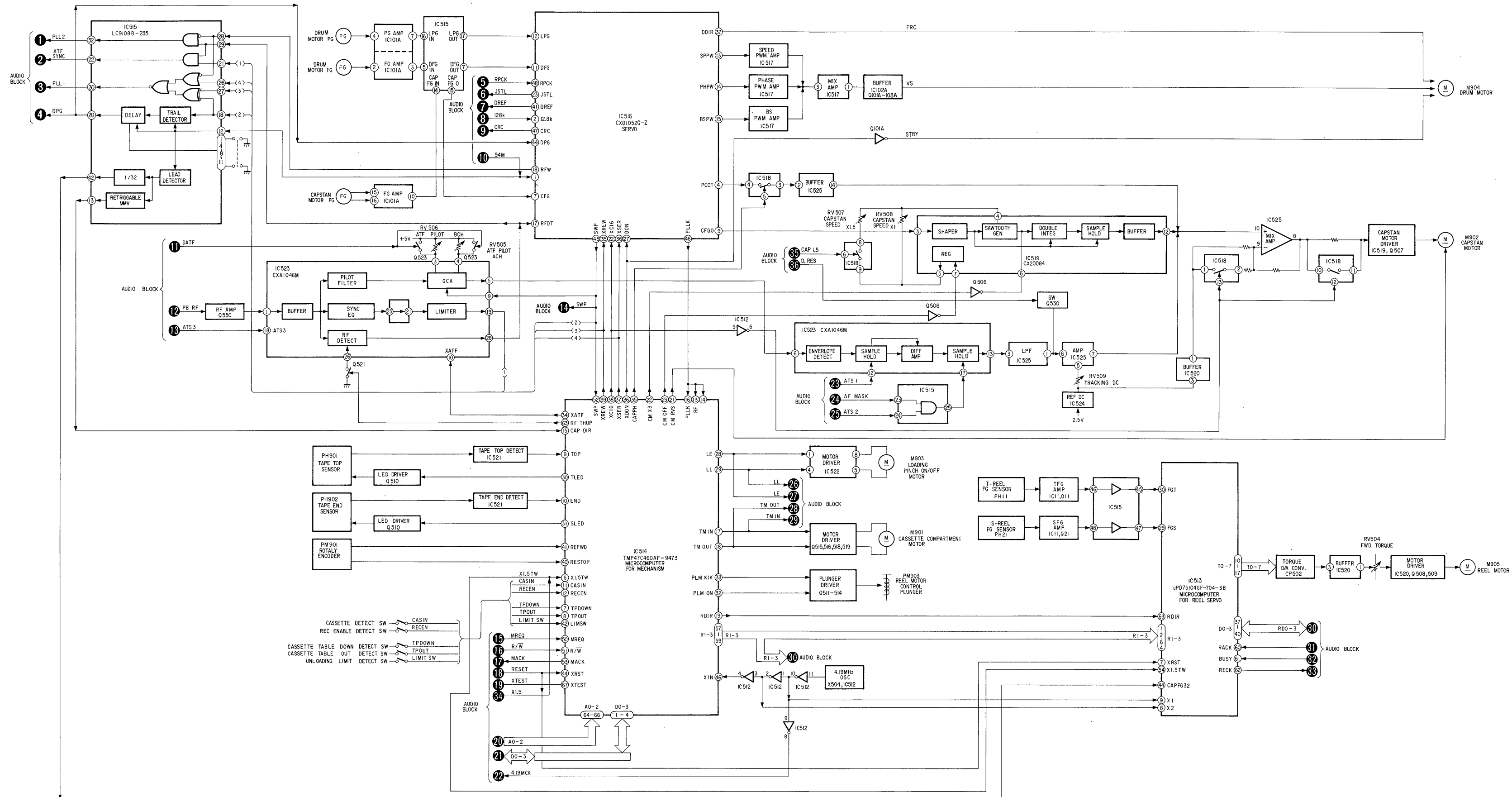

4-2. BLOCK DIAGRAM — AUDIO SECTION —

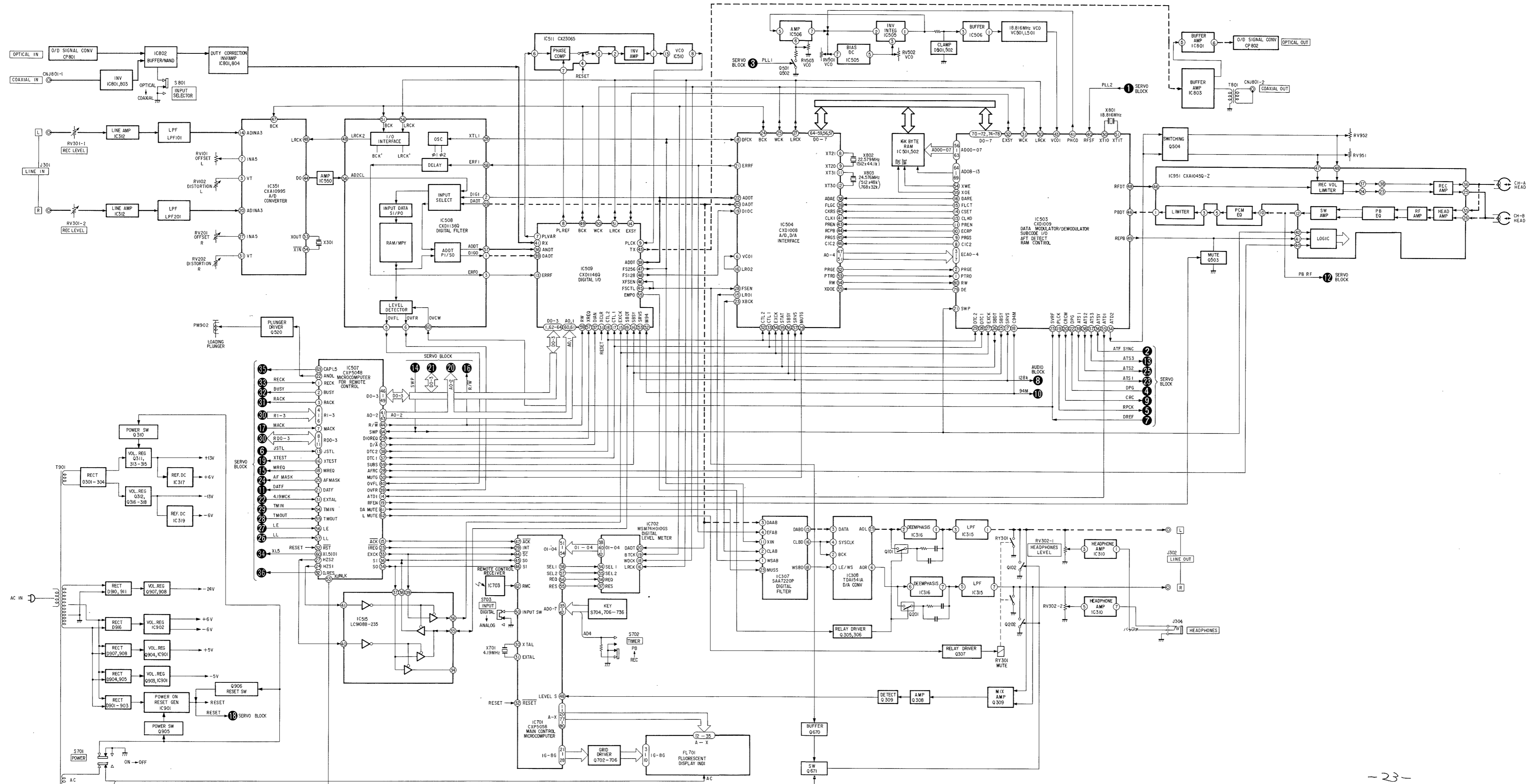

• Semiconductor Location

A1QH3020S



M5F79M05  
M5F79M06

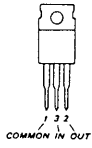

2SA1138  
2SC2676



2SA1409-L  
2SC3623A-L

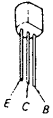

SC7S04F

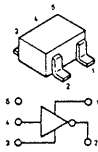

CXD1008Q  
CXD1146Q  
μPD75104GF-704-3B

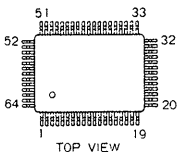

TMP47C460AF-9473

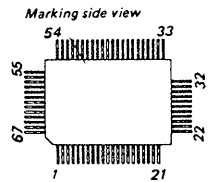

2SB731-F

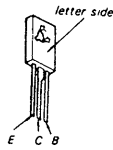

CXD1136Q

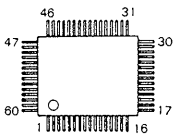

2SB1181F5

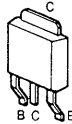

DTA114ES



CX23065A  
M5218L

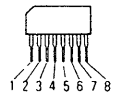

2SC2785-HFE

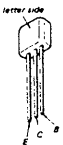

MSM74H010GS-K

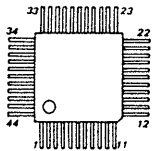

XN4112  
XN4116  
XN4212

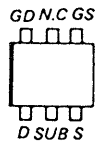

2SK30A-0



M5F78M06

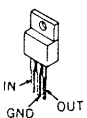

2SA985A-P  
2SB1274SA-Q  
2SC2275-P  
2SD1913SA

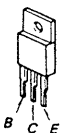



• See page 24 for Semiconductor Lead Layouts.

• Semiconductor Location

Ref. No.	Location	Ref. No.	Location
D501	F-12	IC523	F-6
D502	G-12	IC524	C-23
D503	E-22	IC525	B-2
D504	E-22	IC550	B-9
D505	F-4	IC951	J-10
D506	C-1		
D507	E-22	Q11	I-23
D508	F-2	Q21	J-22
D511	F-2	Q101A	G-26
D670	C-17	Q102A	H-26
		Q103A	G-26
IC11	J-23	Q501	E-14
IC101A	H-26	Q502	E-14
IC102A	I-26	Q503	D-15
IC501	G-15	Q504	D-12
IC502	G-10	Q506	D-1
IC503	E-16	Q507	D-3
IC504	E-10	Q508	G-4
IC505	F-11	Q509	G-21
IC506	F-14	Q510	F-2
IC507	C-6	Q511	F-3
IC508	B-9	Q512	F-3
IC509	B-16	Q513	F-3
IC510	C-14	Q514	F-3
IC511	B-15	Q515	B-22
IC512	E-4	Q516	C-22
IC513	C-19	Q518	C-22
IC514	C-4	Q519	C-21
IC515	F-8	Q520	F-4
IC516	F-18	Q521	F-5
IC517	G-8	Q523	F-20
IC518	D-2	Q530	B-23
IC519	D-23	Q550	G-19
IC520	F-22	Q670	D-17
IC521	F-2	Q671	C-17
IC522	F-21		

Note:  
 • ○ : parts extracted from the component side.  
 • ● : Through hole.  
 • ▨ : Pattern on the side which is seen.  
 • ▩ : Pattern of the rear side.

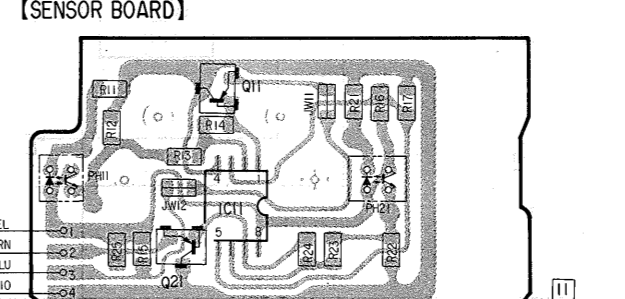
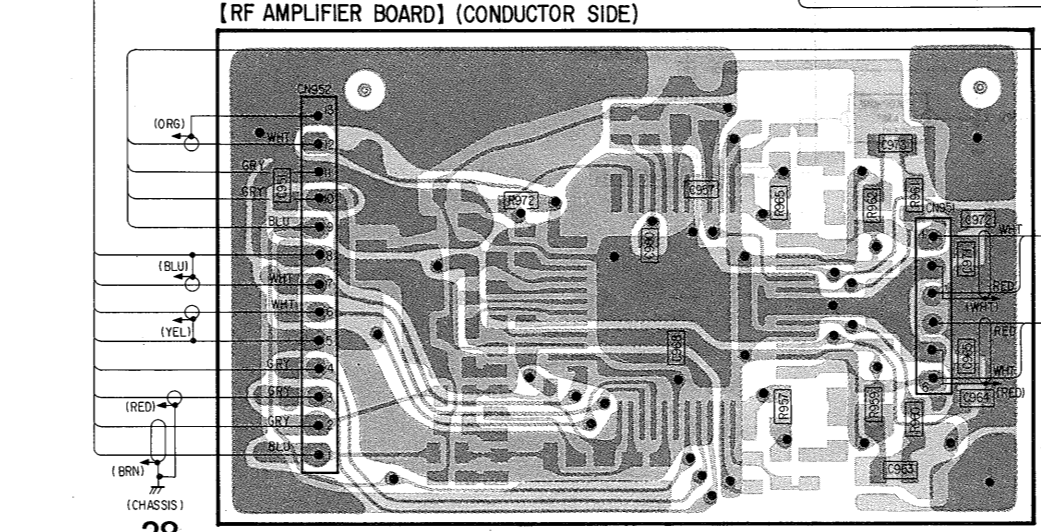
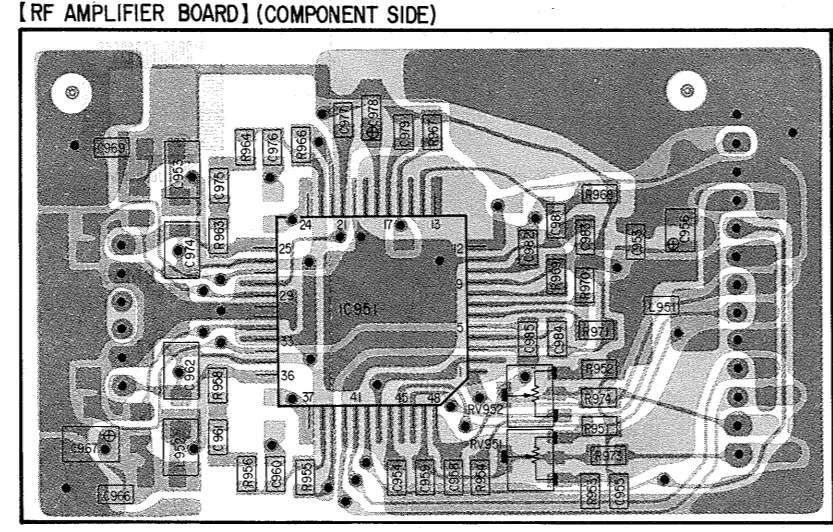
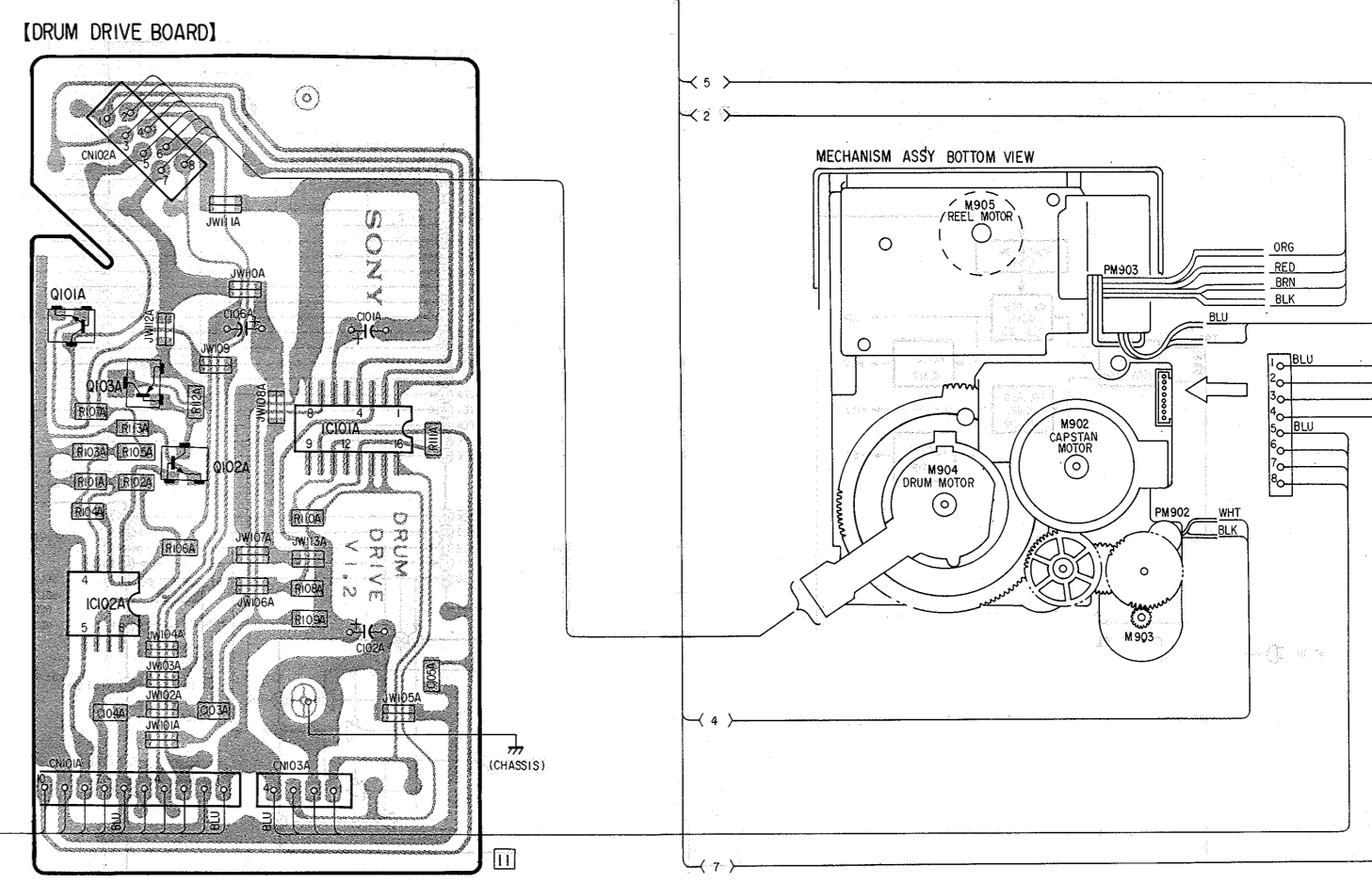
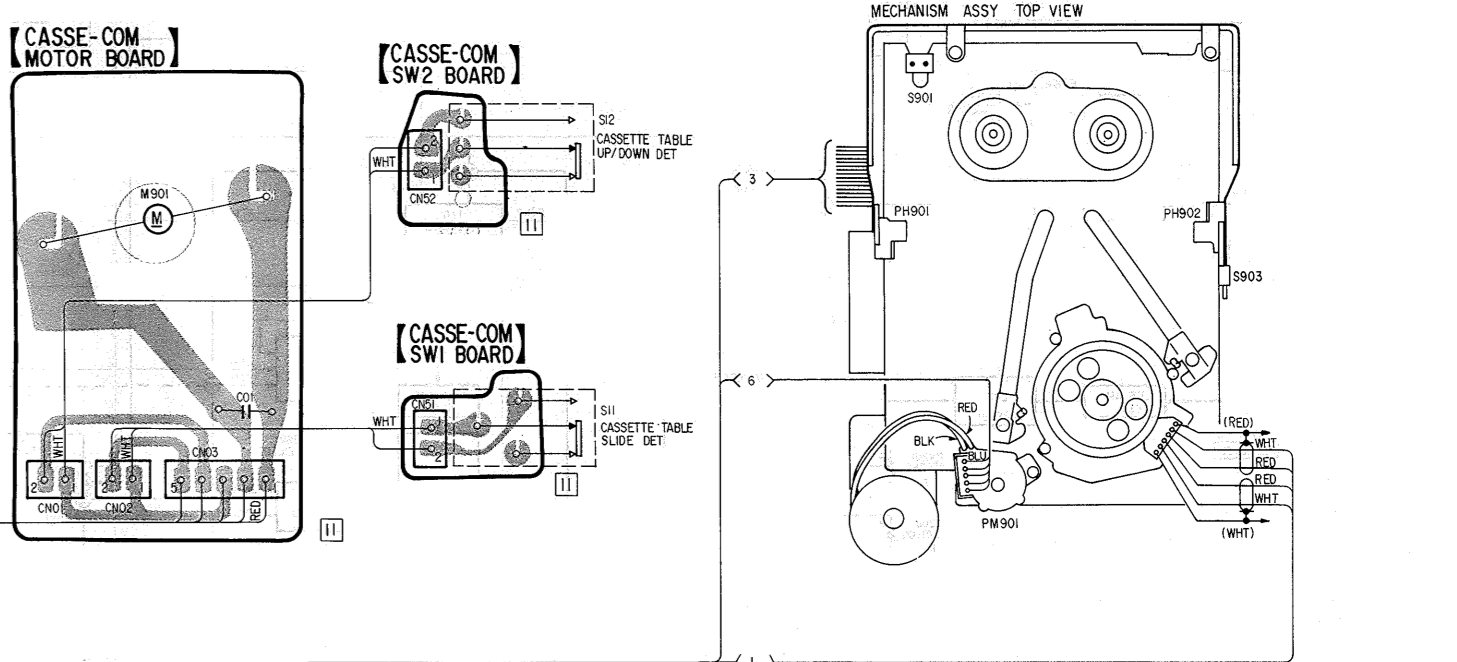
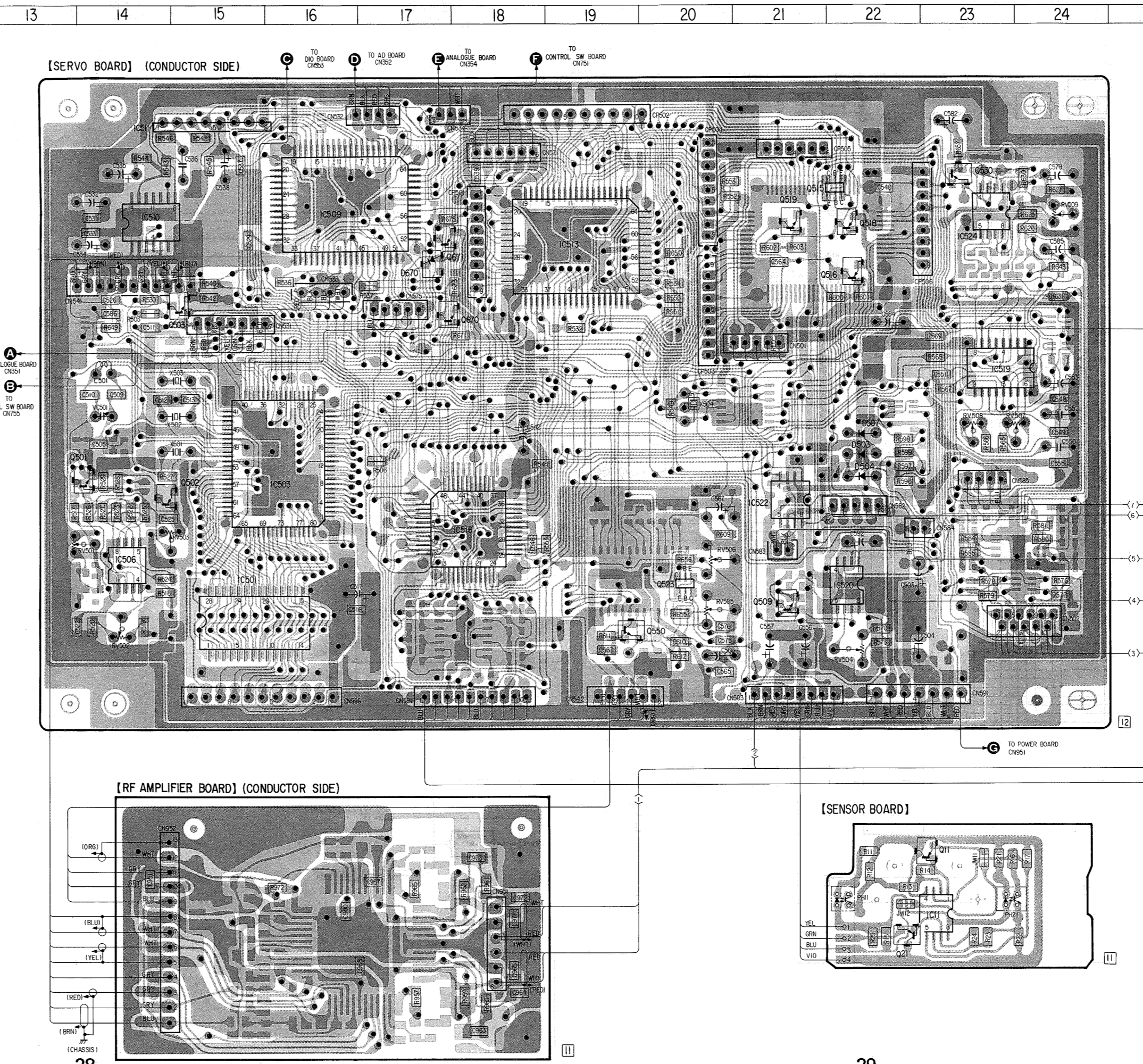
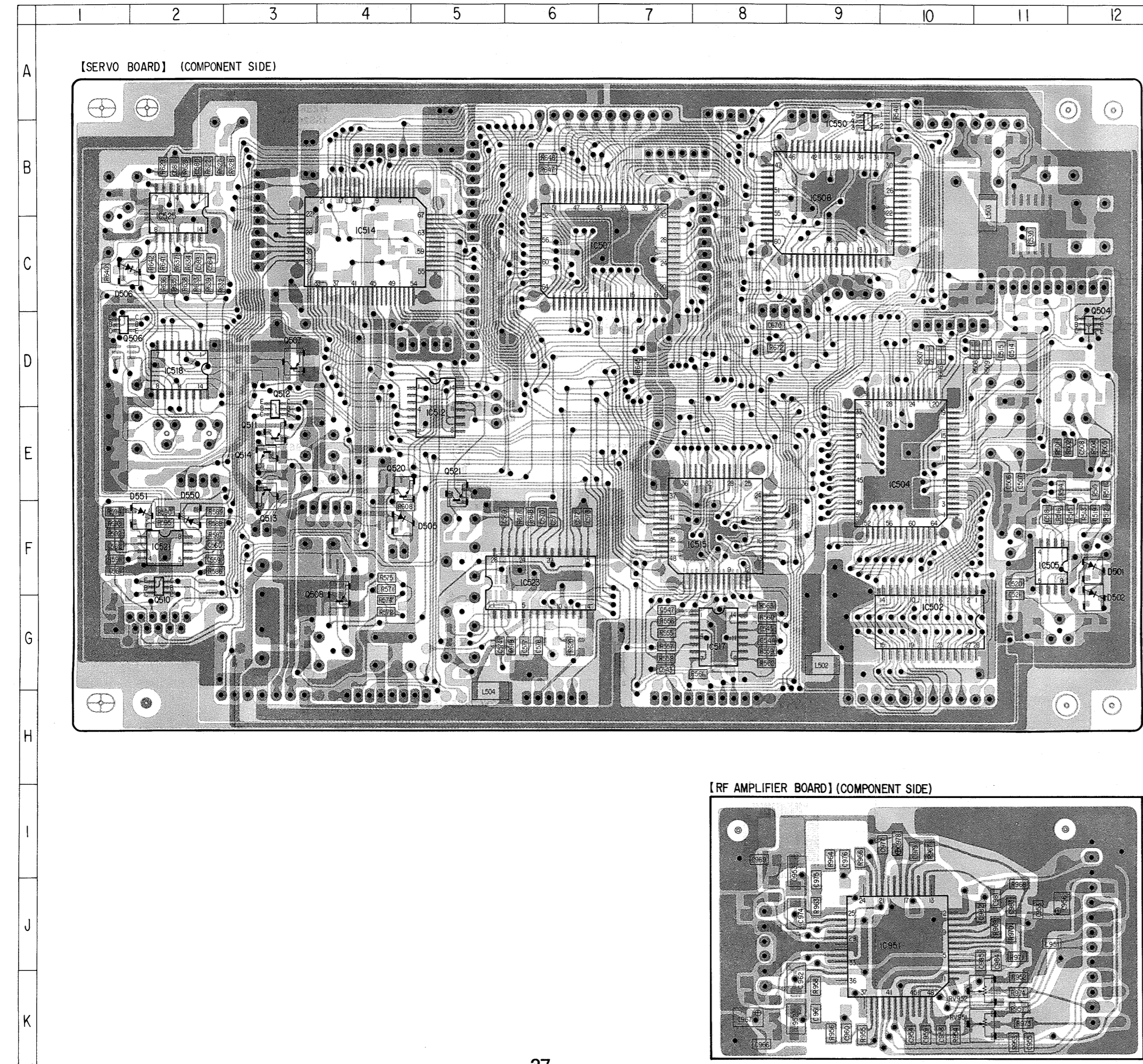



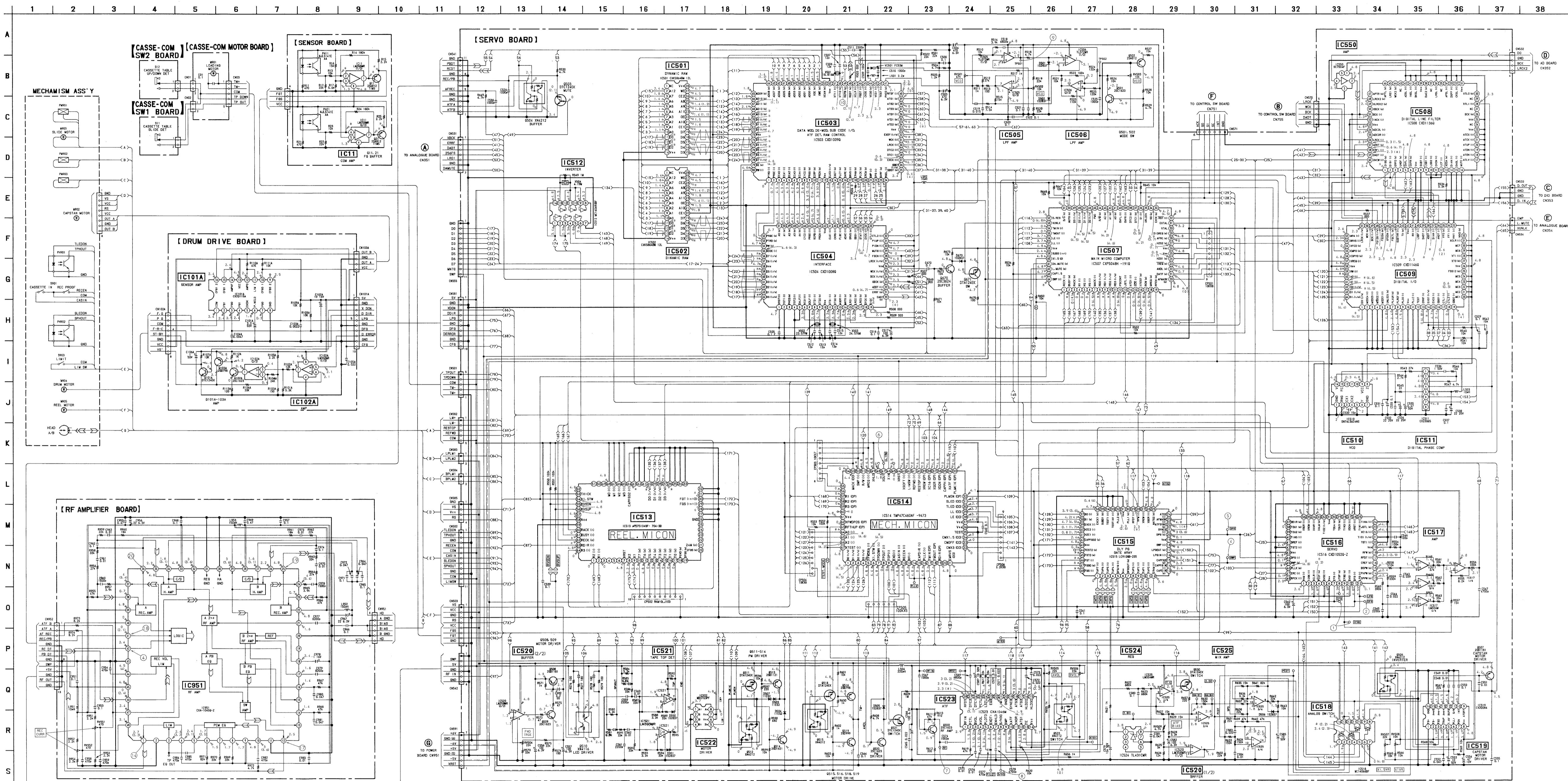

**Note:**

- All capacitors are in  $\mu\text{F}$  unless otherwise noted.  $\text{pF}$ :  $\mu\text{F}$ F
- 50WV or less are not indicated except for electrolytics and tantalums.
- All resistors are in  $\Omega$  and  $\frac{1}{4}\text{W}$  or less unless otherwise specified.
- : fusible resistor.
- : B+ Line
- : B- Line
- : adjustment for repair.
- Voltage and waveforms are dc with respect to ground under no-signal (detuned) conditions.
- no mark: PLAY
- : REC

• Voltages are taken with a VOM (Input impedance 10M  $\Omega$ )

• Voltage variations may be noted due to normal production tolerances.

• Waveforms are taken with an oscilloscope.

• Voltage variations may be noted due to normal production tolerances.

• Circled numbers refer to waveforms. (See page 43)

• Signal path.

• : PB

• : REC

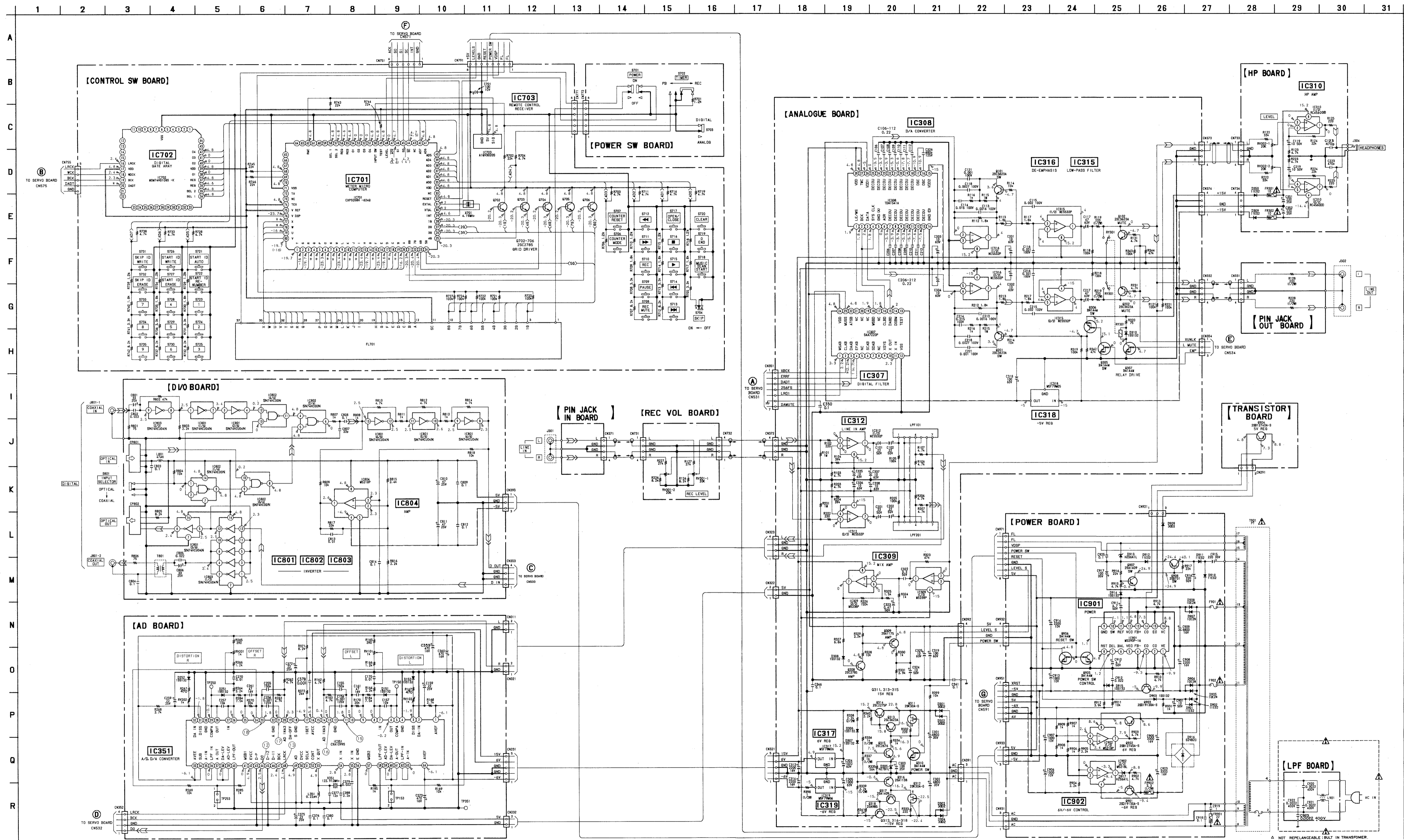

- Note:
- All capacitors are in  $\mu\text{F}$  unless otherwise noted.  $\text{pF}$ ;  $\mu\text{F}$  50WV or less are not indicated except for electrolytics and tantalums.
  - All resistors are in  $\Omega$  and  $\frac{1}{4}\text{W}$  or less unless otherwise specified.
  - : fusible resistor.
  - : B+ Line
  - : B- Line
  - : adjustment for repair.
  - Voltage and waveforms are dc with respect to ground under no-signal (detuned) conditions.
  - no mark : PLAY
  - ( ) : REC
  - Voltages are taken with a VOM (input impedance 10M  $\Omega$ )
  - Voltage variations may be noted due to normal production tolerances.
  - Waveforms are taken with an oscilloscope.
  - Voltage variations may be noted due to normal production tolerances.
  - Circled numbers refer to waveforms. (See page 43)
  - Signal path.
  - : PS
  - : REC

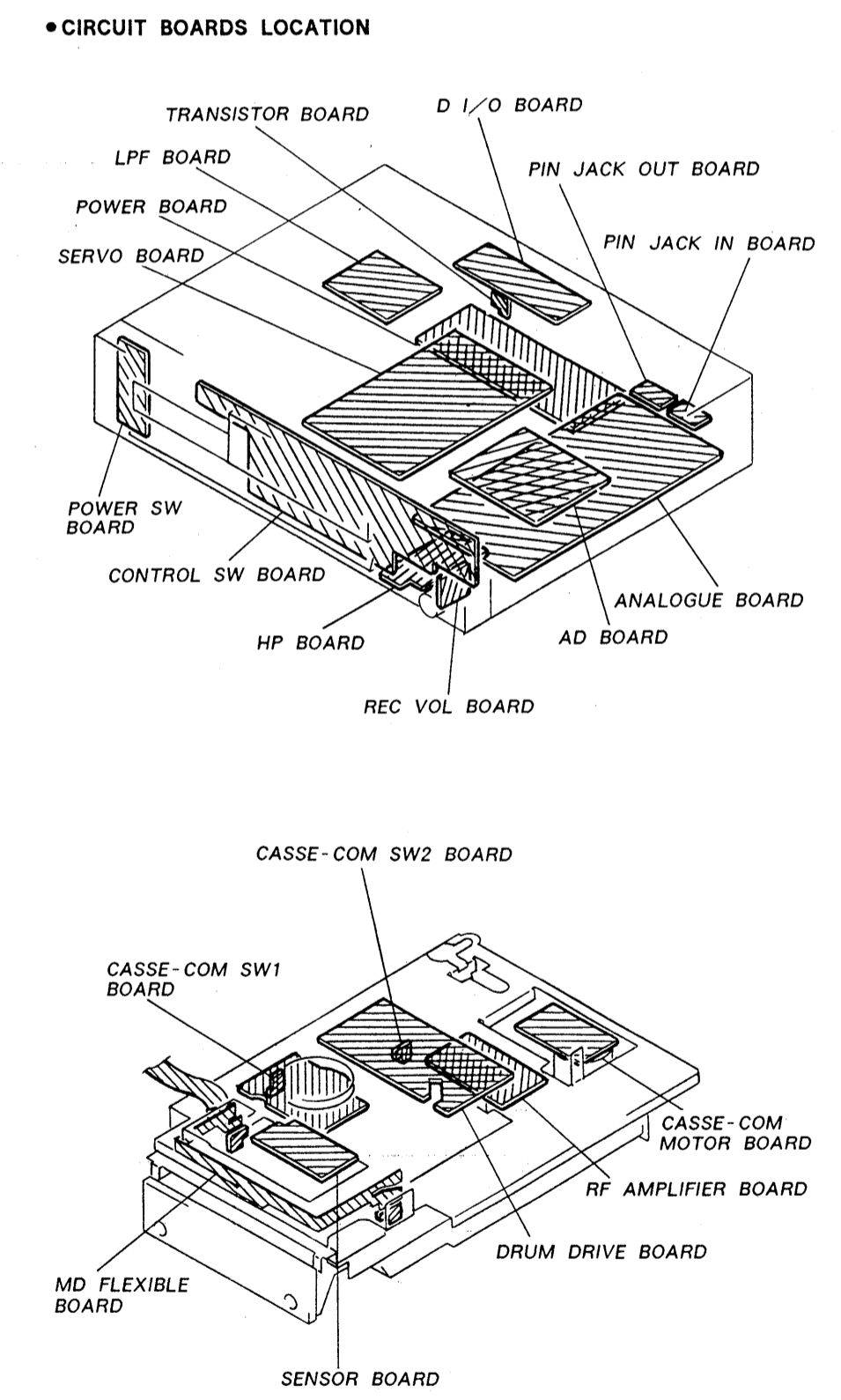



• See page 24 for Semiconductor Lead Layouts.







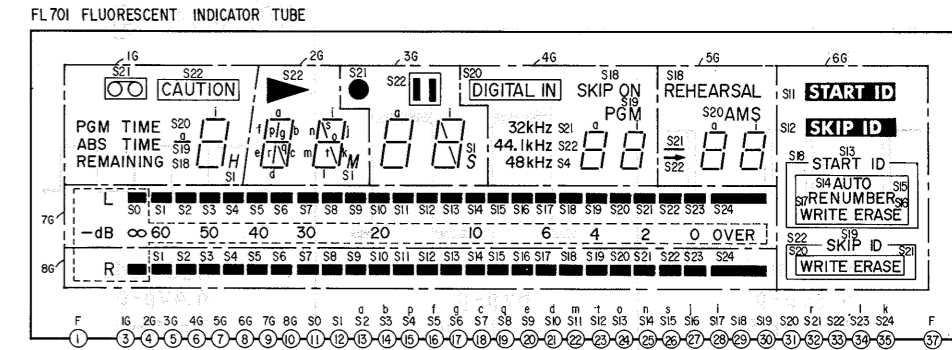
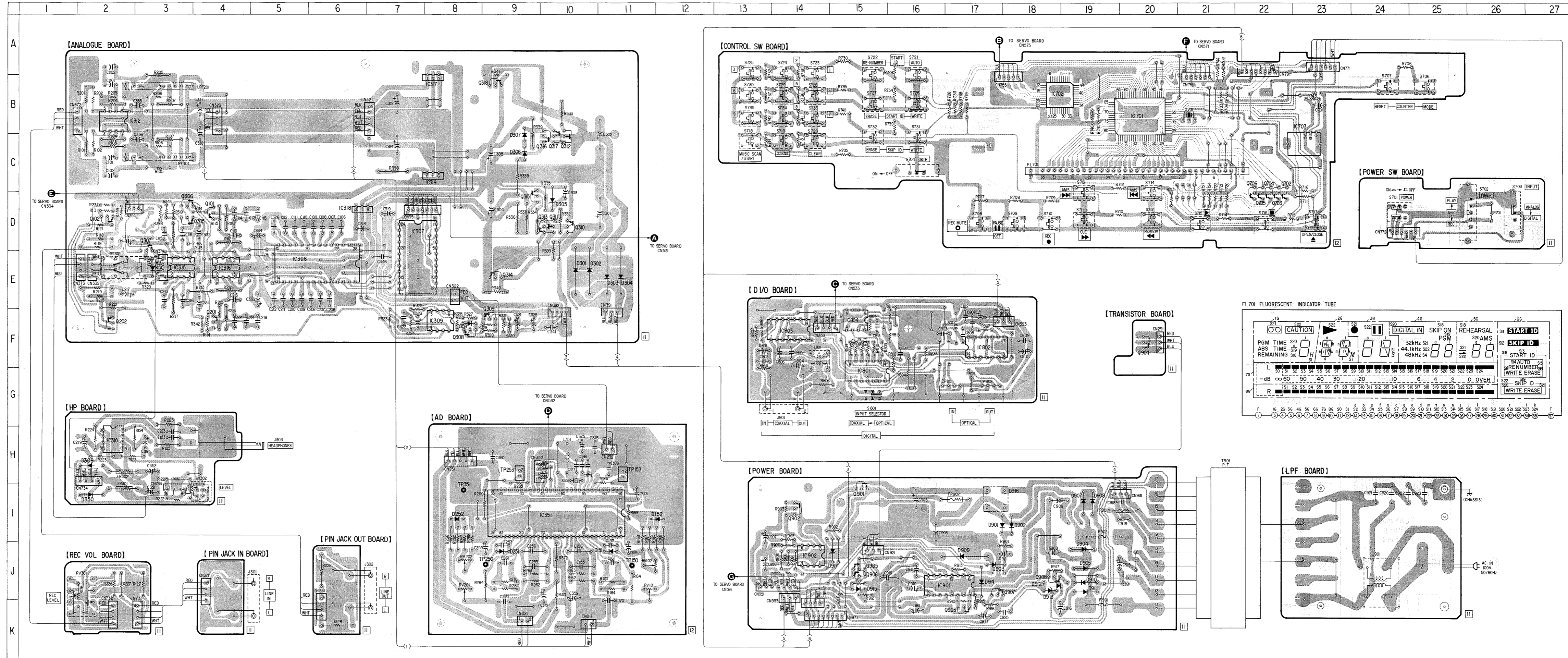





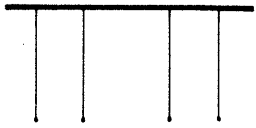

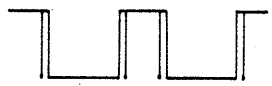
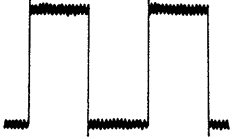

• Semiconductor Location

Ref. No.	Location	Ref. No.	Location
D151	J-11	IC701	B-20
D152	I-12	IC702	B-18
D251	J-9	IC703	C-23
D252	I-8	IC801	G-15
D301	E-10	IC802	F-17
D302	E-10	IC803	F-14
D303	E-11	IC804	F-15
D304	E-11	IC901	J-16
D305	D-10	IC902	J-14
D306	C-9		
D307	C-9	Q101	D-4
D308	F-8	Q102	D-2
D309	H-2	Q201	F-4
D310	E-3	Q202	F-2
D350	H-2	Q305	D-3
D901	I-17	Q306	D-3
D902	I-18	Q307	D-3
D903	J-17	Q308	F-8
D904	J-19	Q309	F-9
D905	J-19	Q310	D-10
D907	I-19	Q311	D-10
D908	I-19	Q312	C-10
D909	J-17	Q313	D-10
D910	J-19	Q314	E-9
D911	J-19	Q315	D-9
D912	J-18	Q316	C-10
D913	J-18	Q317	C-10
D914	J-17	Q318	B-9
D915	J-15	Q702	D-22
D916	I-17	Q703	D-22
D917	J-15	Q704	D-22
		Q705	D-22
IC307	D-7	Q706	D-22
IC308	E-5	Q901	I-15
IC309	F-8	Q902	I-14
IC310	H-2	Q903	K-17
IC312	B-2	Q904	F-20
IC315	E-3	Q905	J-15
IC316	E-4	Q906	J-15
IC317	B-8	Q907	J-17
IC318	D-6	Q908	J-18
IC319	C-8		
IC351	I-10		

Note:  
 ○ : parts extracted from the component side.  
 ● : Through hole.  
 ▨ : Pattern on the side which is seen.

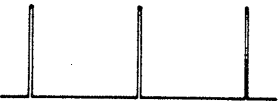
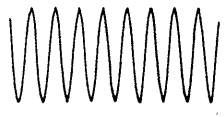

• Waveform List

<p>① IC516 ⑦, ⑨ (CFG 1, CFG 0)</p>  <p>PLAY/REC mode 5Vp-p T = 1.5mS</p>	<p>⑥ IC514 ④⑦ (4.19MHz)</p>  <p>3.6Vp-p T = 0.24μS</p>	<p>⑪ IC523 ⑫ (ATS 1)</p>  <p>PLAY mode 4.8Vp-p T = 15mS</p>	<p>⑯ IC351 ⑬, ⑳</p>  <p>0.32Vp-p T = 52μS</p>
<p>② IC516 ⑪ (DFG)</p>  <p>PLAY/REC mode 5Vp-p T = 1.2mS</p>	<p>⑦ Q550 ③ (RF)</p>  <p>PLAY mode 0.9Vp-p T = 22mS</p>	<p>⑫ IC351 ④④</p>  <p>5.6Vp-p T = 5μS</p>	<p>⑰ IC951 ⑫</p>  <p>PLAY mode 0.36Vp-p T = 29mS</p>
<p>③ IC351 ④⑦ (BCK)</p>  <p>5.8Vp-p T = 0.325μS</p>	<p>⑧ IC523 ⑳ (RFDT)</p>  <p>PLAY mode 4.8Vp-p T = 9.5mS</p>	<p>⑬ IC351 ④⑧</p>  <p>6Vp-p T = 10.1μS</p>	<p>⑱ IC951 ④①</p>  <p>REC mode 4.4Vp-p T = 15mS</p>
<p>④ IC516 ④⑤ IC951 ④② (SWP)</p>  <p>PLAY/REC mode 5Vp-p T = 29mS</p>	<p>⑨ IC505 ①</p>  <p>PLAY mode 1.3Vp-p T = 15mS</p>	<p>⑭ IC951 ①</p>  <p>PLAY mode 1.8Vp-p T = 15mS</p>	<p>⑲ IC951 ⑳</p>  <p>REC mode 5.7Vp-p T = 30mS</p>
<p>⑤ IC515 ⑳ IC516 ④④ (DPG)</p>  <p>PLAY/REC mode 5Vp-p T = 30mS</p>	<p>⑩ IC503 ⑤①</p>  <p>2Vp-p T = 0.053μS</p>	<p>⑮ IC351 ⑪, ⑳</p>  <p>3.9Vp-p T = 52μS</p>	<p>⑳ IC951 ③⑥</p>  <p>REC mode 3.9Vp-p T = 30mS</p>

## SECTION 5 EXPLODED VIEWS

**NOTE:**

- The mechanical parts with no reference number in the exploded views are not supplied.
- The construction parts of an assembled part are indicated with a collation number in the remark column.
- Items marked "★" are not stocked since they are seldom required for routine service. Some delay should be anticipated when ordering these items.

- Due to standardization, parts with part number suffix -XX and -X may be different from the parts specified in the components used on the set.
- Color Indication of Appearance Parts  
Example:  
(RED) ... KNOB, BALANCE (WHITE)  
↑ Cabinet's Color                      ↑ Parts Color

The components identified by mark or dotted line with mark are critical for safety. Replace only with part number specified.

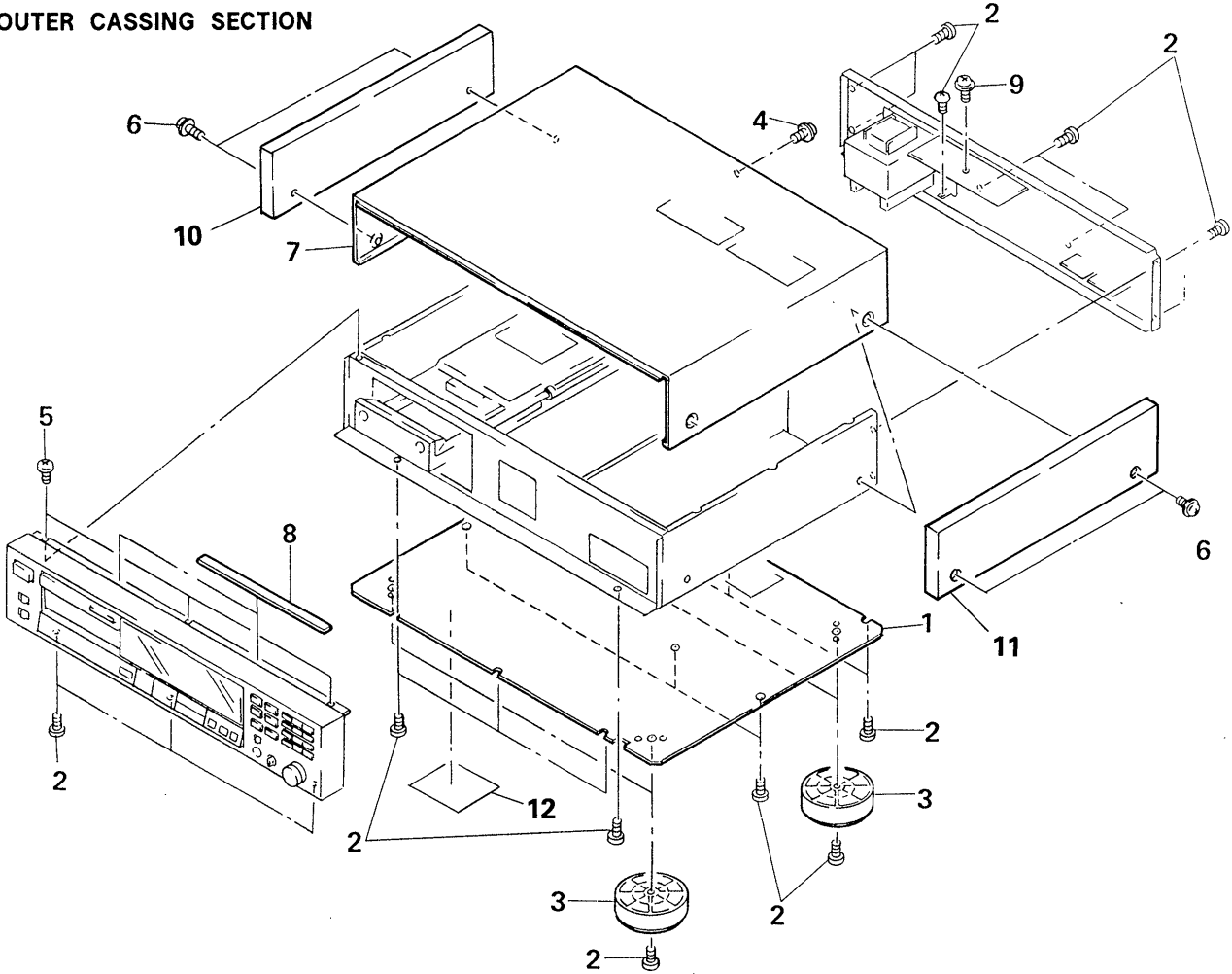

**5-1. OUTER CASSING SECTION**

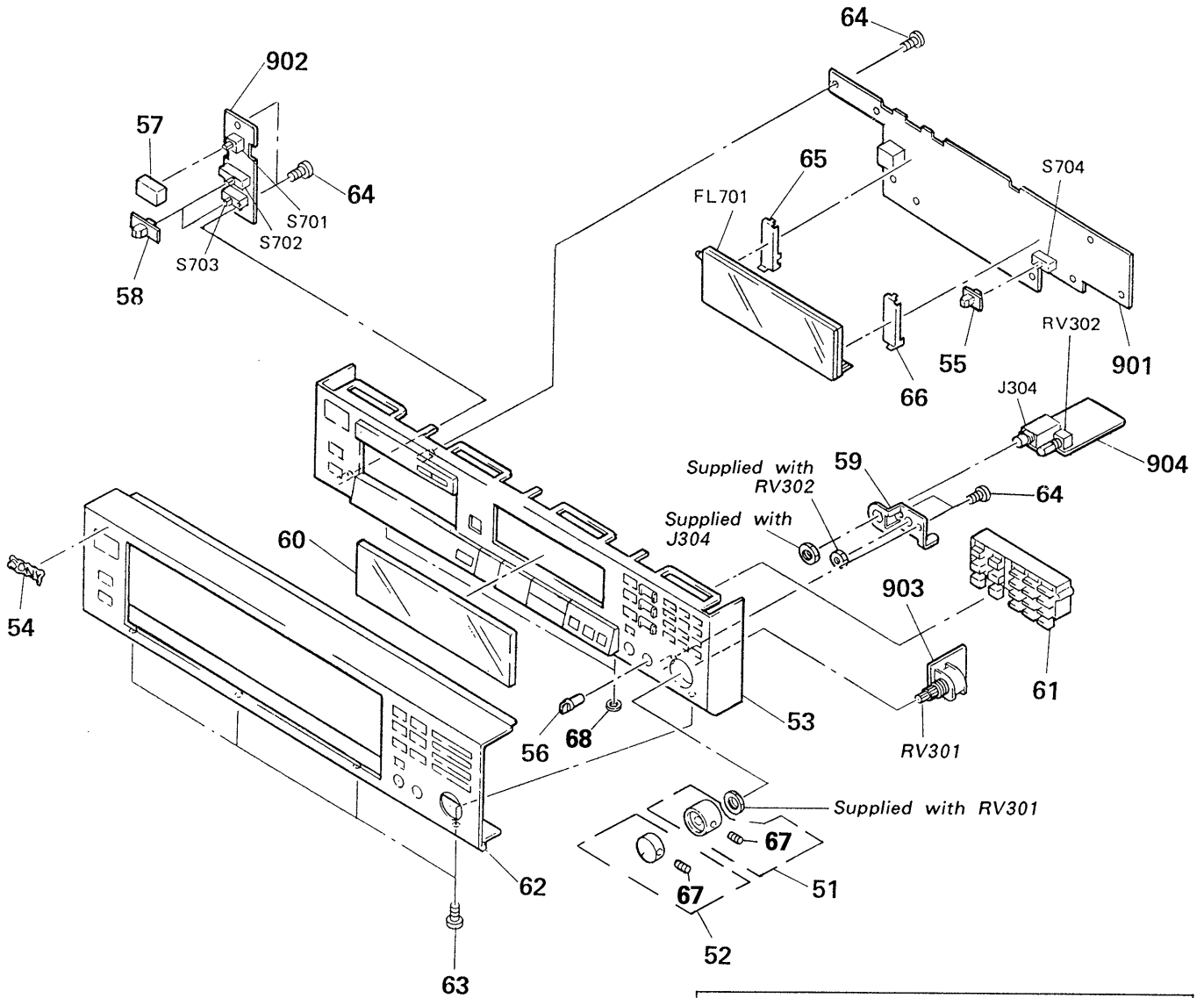

No.	Part No.	Description	Remarks	No.	Part No.	Description	Remarks
1	*4-931-433-11	PLATE, BOTTOM		7	4-925-721-21	CASE	
2	7-685-872-09	SCREW +BVTT 3X8 (S)		8	*4-925-690-01	CUSHION (F)	
3	X-3304-938-2	FOOT ASSY		9	4-886-821-11	SCREW, S TIGHT, +PTTWH 3X6	
4	3-704-366-01	SCREW (CASE) (M3X8)		10	X-4919-018-1	BOARD (LEFT) ASSY, SIDE	
5	7-682-547-09	SCREW +B 3X6		11	X-4919-017-1	BOARD (RIGHT) ASSY, SIDE	
6	4-919-060-01	SCREW (M4X20), RING (+)		12	*4-931-441-01	SHEET, VIBRATION PROOF	

## 5-2. FRONT PANEL SECTION



**Note:** The components identified by mark  or dotted line with mark  are critical for safety. Replace only with part number specified.

No.	Part No.	Description	Remarks	No.	Part No.	Description	Remarks
51	X-4919-006-1	KNOB (REC-LEFT) ASSY		67	3-701-506-01	SET SCREW, DOUBLE POINT 3X4	
52	X-4919-007-1	KNOB (REC-RIGHT) ASSY		68	3-344-781-01	WASHER, POLYETHYLENE	
53	X-4919-013-1	ESCUTCHEON ASSY		901	*A-2006-080-A	MOUNTED PCB, CONTROL SW	
54	4-908-848-01	EMBLEM, SONY		902	*1-630-193-11	PC BOARD, POWER SW	
55	4-918-972-01	KNOB, SLIDE SW		903	*1-630-192-11	PC BOARD, REC VOL	
56	4-922-531-01	KNOB (A TYPE), LOV		904	*1-630-191-11	PC BOARD, HP	
57	4-922-921-01	BUTTON (POWER)		FL701	1-519-472-11	INDICATOR TUBE, FLUORESCENT	
58	4-931-421-01	KNOB (T & S)		J304	1-565-327-11	JACK, LARGE TYPE 1P (HEADPHONES)	
59	*4-931-422-01	BRACKET (P & V)		RV301	1-238-520-11	RES, VAR, CARBON 20K/20K (REC LEVEL)	
60	4-931-423-01	WINDOW (FL TUBE)		RV302	1-238-359-11	RES, VAR, CARBON 20K/20K (HEADPHONES LEVEL)	
61	4-931-437-01	BUTTON (10 KEY)		S701	 1-571-305-11	SWITCH, PUSH (1 KEY)(POWER)	
62	4-931-438-11	PANEL, FRONT		S702	1-571-520-11	SWITCH, SLIDE (TIMER)	
63	7-685-133-19	SCREW +BTP 2.6X6 TYPE2 N-S		S703	1-570-974-11	SWITCH, SLIDE (INPUT)	
64	7-685-534-19	SCREW +BTP 2.6X8 TYPE2 N-S		S704	1-570-974-11	SWITCH, SLIDE (SKIP)	
65	*4-922-524-01	HOLDER (LEFT)					
66	*4-922-523-01	HOLDER (RIGHT)					

### 5-3. REAR PANEL SECTION

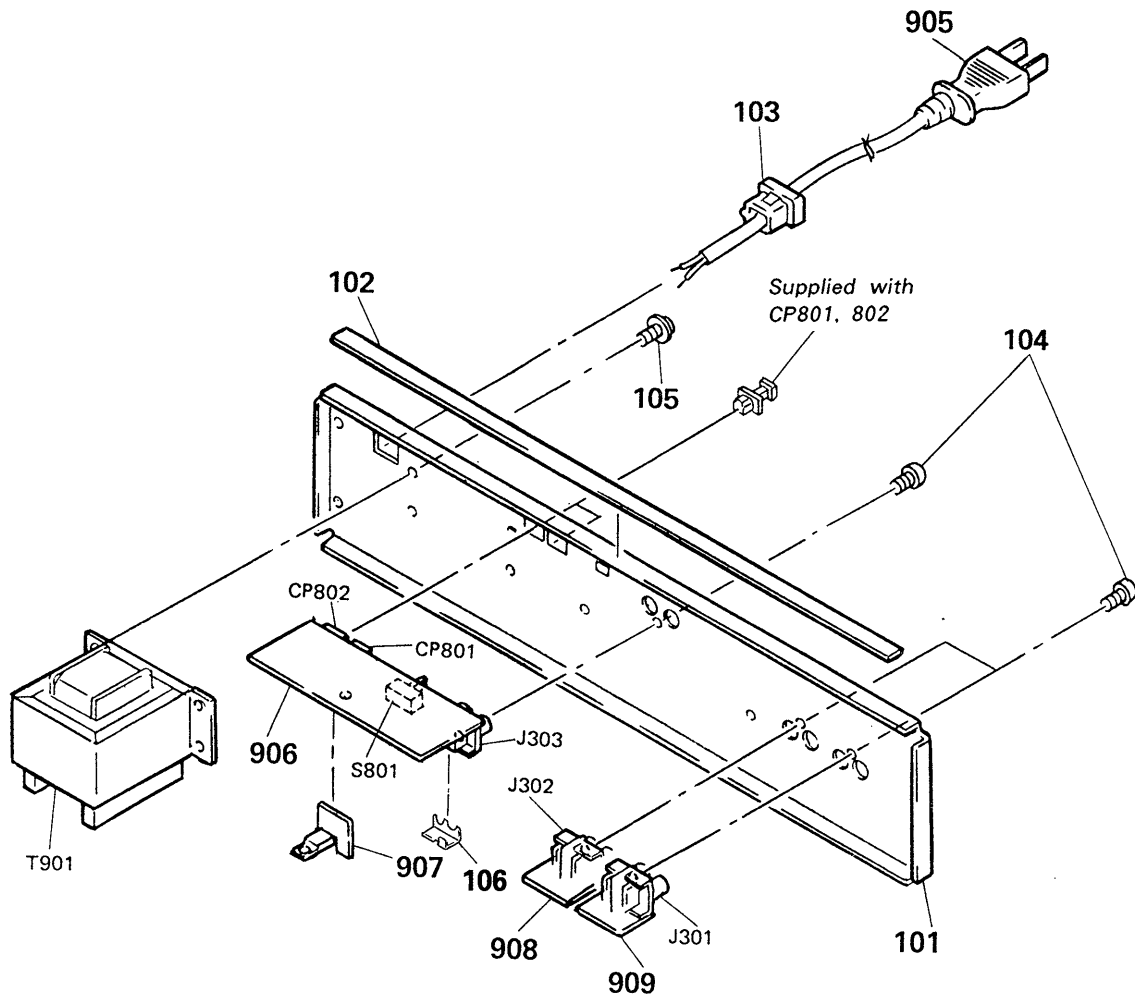

**Note:** The components identified by mark  $\triangle$  or dotted line with mark  $\triangle$  are critical for safety. Replace only with part number specified.

No.	Part No.	Description	Remarks	No.	Part No.	Description	Remarks
101	*4-925-785-21	PANEL, BACK		908	*1-630-567-11	PC BOARD, PIN JACK OUT	
102	*4-925-691-01	CUSHION (B)		909	*1-630-566-11	PC BOARD, PIN JACK IN	
103	*3-703-244-00	BUSHING (2104), CORD		CP801	1-464-931-11	RECEIVE UNIT, RAY	
104	7-621-849-00	SCREW, TAPPING		CP802	1-464-878-11	TRANSMITTER UNIT, RAY	
105	3-704-366-01	SCREW (CASE) (M3X8)		J301	1-565-319-71	JACK, PIN 2P (LINE IN)	
106	*4-928-177-01	PLATE, GROUND		J302	1-565-319-71	JACK, PIN 2P (LINE OUT)	
905	$\triangle$ 1-555-795-00	CORD, POWER		J801	1-565-319-61	JACK, PIN 2P (OAX 1AL)	
906	*1-630-188-11	PC BOARD, D I/O		T901	$\triangle$ 1-449-779-11	TRANSFORMER, POWER	
907	*1-630-568-11	PC BOARD, TRANSISTOR					



5-4. MAIN BOARD SECTION

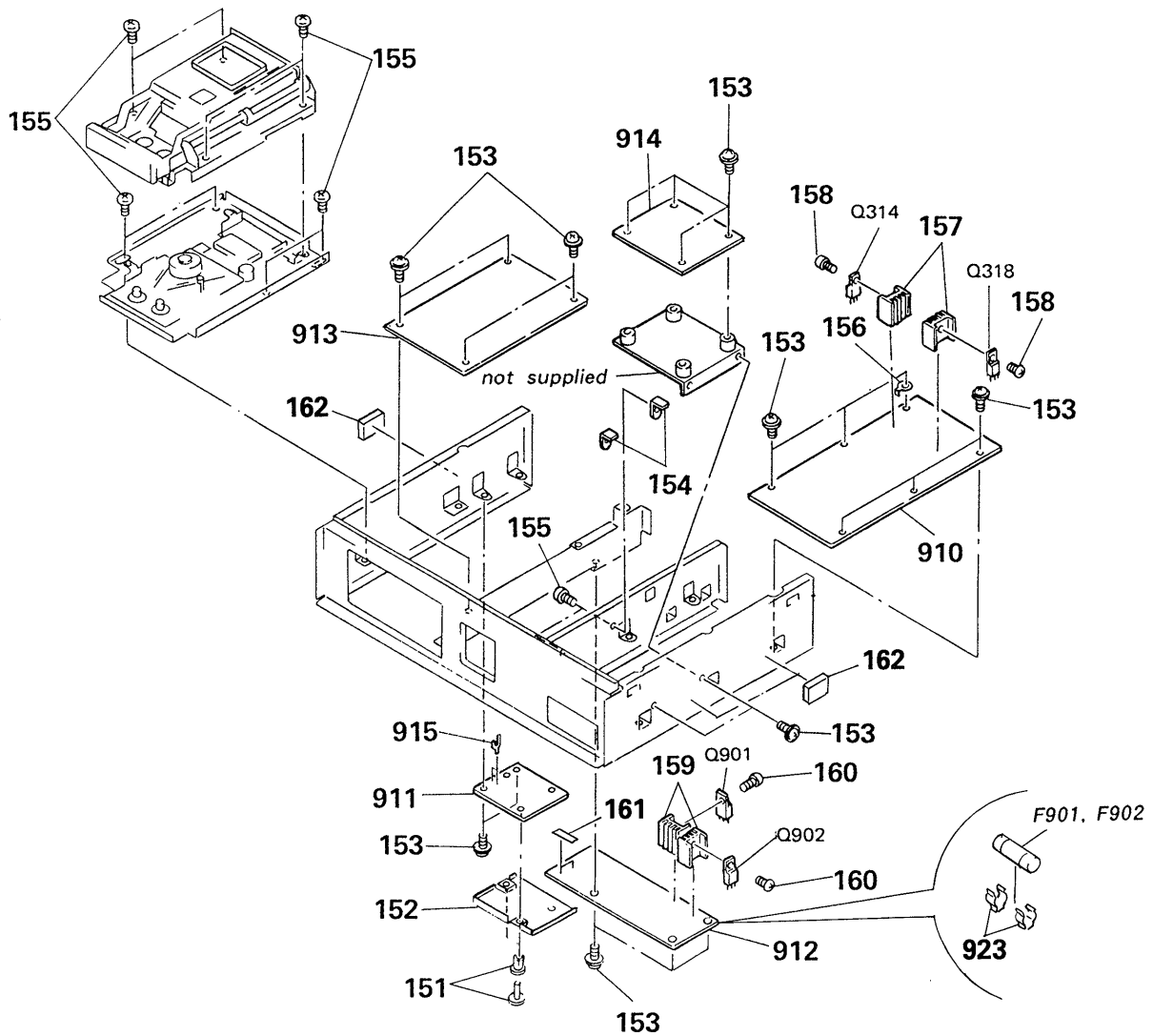

**Note:** The components identified by mark  $\triangle$  or dotted line with mark  $\triangle$  are critical for safety. Replace only with part number specified.

No.	Part No.	Description	Remarks	No.	Part No.	Description	Remarks
151	3-531-576-01	RIVET, NYLON		910	*A-2006-180-A	MOUNTED PCB, ANALOGUE	
152	*4-925-790-01	COVER (POWER)		911	*1-630-190-11	PC BOARD, LPF	
153	3-531-576-01	RIVET		912	*A-2006-078-A	MOUNTED PCB, POWER	
153	4-886-821-11	SCREW, S TIGHT, +PTTWH 3X6		913	*A-2006-079-A	MOUNTED PCB, SERVO	
154	*4-923-506-11	BRACKET (PC BOARD)		914	*A-2006-183-A	MOUNTED PCB, AD	
155	7-682-547-09	SCREW +BVTT 3X6 (S)		915	*1-535-771-11	TERMINAL	
156	4-870-539-00	PLATE, GROUND		923	1-533-162-00	HOLDER, FUSE	
157	*4-363-146-71	HEAT SINK, V.OUT		F901	$\triangle$ 1-532-286-00	FUSE, TIME-LAG (2.5A)	
158	7-682-147-15	SCREW, TR		F902	$\triangle$ 1-532-286-00	FUSE, TIME-LAG (2.5A)	
159	*4-931-401-01	HEAT SINK, V.OUT					
160	7-682-547-09	SCREW +BVTT 3X6 (S)					
161	3-701-947-15	LABEL (T2.5A), FUSE					
162	9-911-840-XX	CUSHION					

5-5. MECHANISM ASSEMBLY

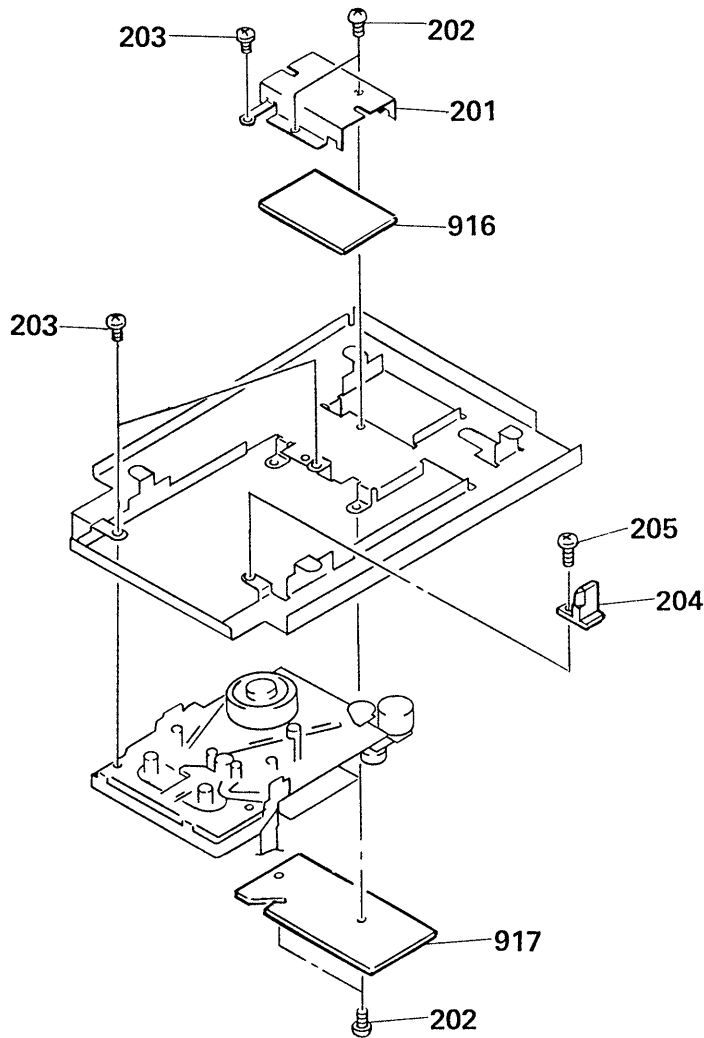

No.	Part No.	Description	Remarks	No.	Part No.	Description	Remarks
201	*3-345-196-01	CASE, SHIELD		205	7-621-772-38	SCREW +B 2X6	
202	7-621-770-87	SCREW +B 2.6X5		916	*A-2006-059-A	MOUNTED PCB, RF AMPLIFIER	
203	7-621-772-18	SCREW +B 2X4		917	*1-630-186-11	PC BOARD, DRUM DRIVE	
204	*4-923-751-01	HOLDER (A)					

## 5-6. DATM BLOCK ASSEMBLY-1

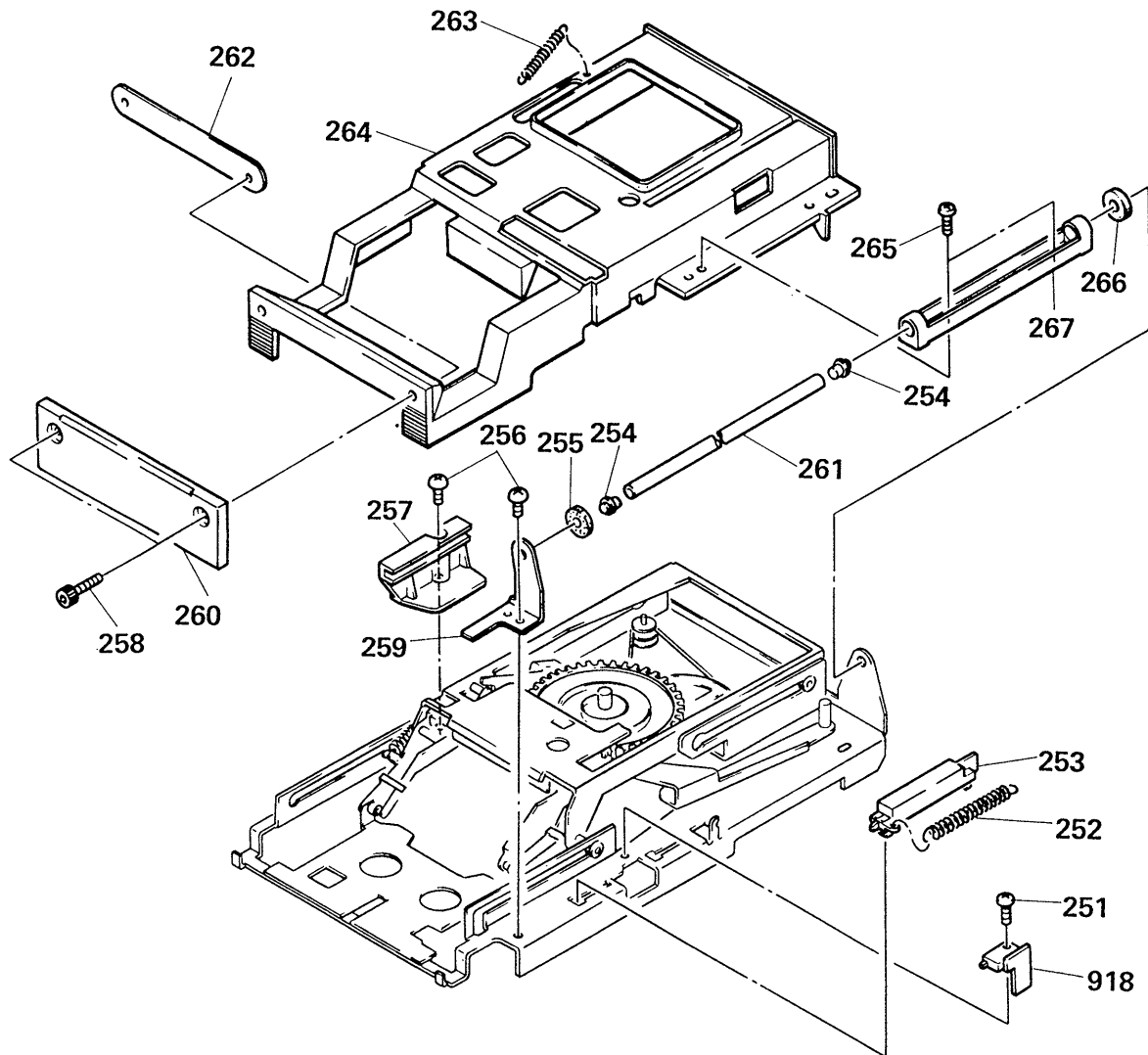

No.	Part No.	Description	Remarks	No.	Part No.	Description	Remarks
251	7-621-255-40	SCREW +P 2X6		260	4-931-424-01	PANEL (CASSETTE COMPARTMENT)	
252	4-925-725-01	SPRING, TENSION		261	4-931-405-01	SHAFT (PP)	
253	*4-923-773-01	SLIDER (OP)		262	*4-923-737-01	BRACKET (LP)	
254	4-931-418-01	SHAFT (JOINT)		263	4-925-735-01	SPRING, TENSION	
255	*4-912-587-11	CUSHION		264	*4-923-789-01	HOLDER (TRAY), CASSETTE	
256	7-682-547-04	SCREW +BVTT 3X6 (S)		265	7-685-534-19	SCREW +BTP 2.6X8 TYPE2 N-S	
257	*4-923-772-01	SLIDER (T)		266	*4-912-587-01	CUSHION	
258	7-683-413-05	BOLT, HEXAGON SOCKET 2.6X8		267	*4-923-771-01	BEARING	
259	*4-923-739-01	BRACKET (SS)		918	*1-630-195-11	PC BOARD, CASSE-COM SW1	

5-7. DATM BLOCK ASSEMBLY-2

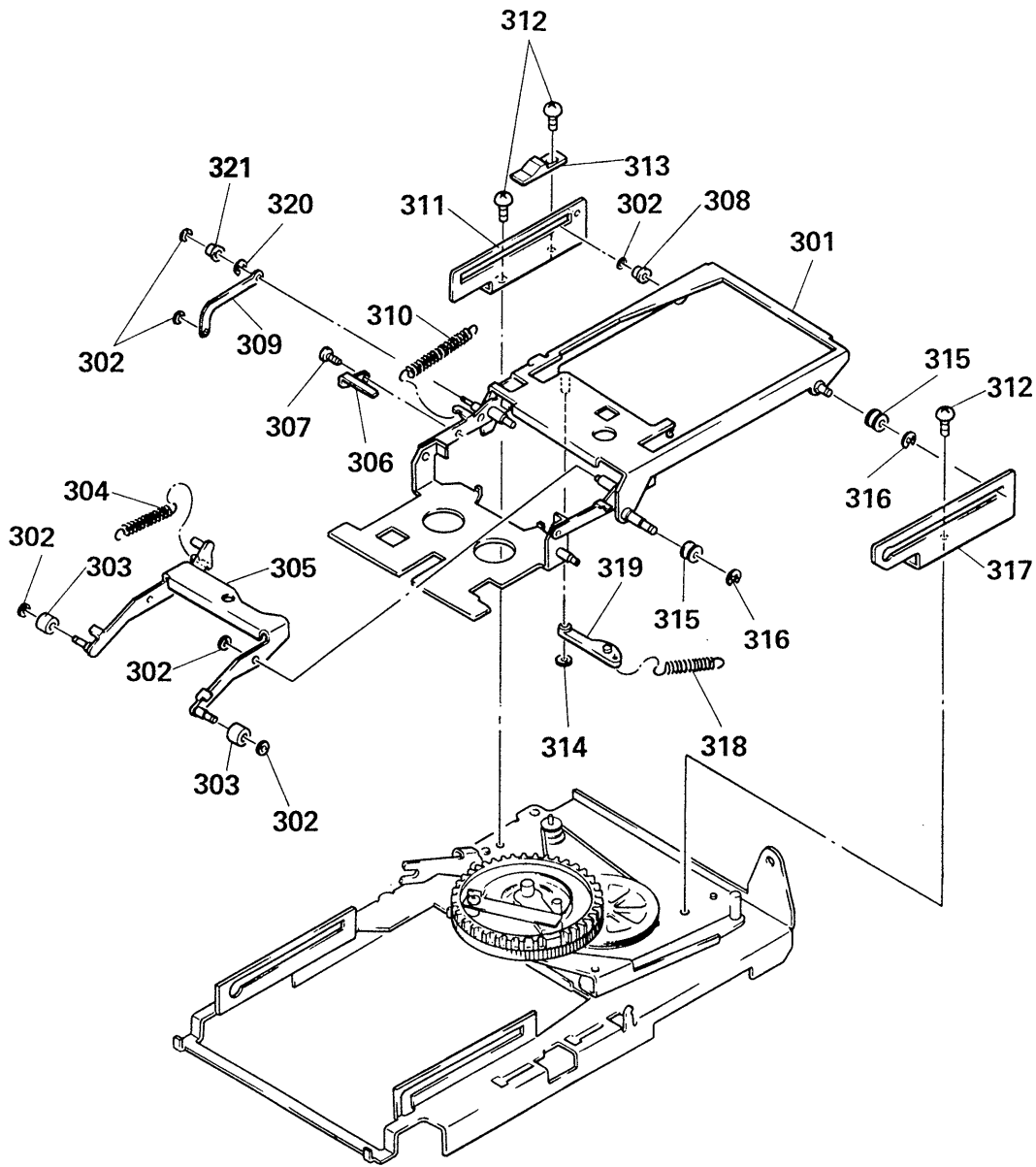

No.	Part No.	Description	Remarks	No.	Part No.	Description	Remarks
301	X-4919-012-1	SLIDER ASSY		311	*4-923-755-01	SLIDER (S)	
302	3-321-813-01	WASHER, COTTER POLYETHYLENE		312	7-682-547-04	SCREW +BVT 3X6 (S)	
303	4-918-946-01	ROLLER, PRESS		313	*4-923-752-11	HOLDER (B)	
304	3-549-810-00	SPRING, TENSION		314	3-325-290-21	WASHER, STOPPER	
305	X-4919-009-1	LEVER (DW) ASSY		315	4-923-754-01	ROLLER (M)	
306	*4-923-740-01	BRACKET (UP)		316	7-624-102-04	STOP RING 1.5, TYPE -E	
307	7-627-553-37	SCREW, PRECISION +P 2X3		317	*4-923-756-01	SLIDER (M)	
308	4-923-753-01	ROLLER (S)		318	3-465-159-XX	SPRING, TENSION	
309	*4-923-746-01	LEVER (LL)		319	*4-923-743-01	LEVER (KC)	
310	4-925-765-01	SPRING, TENSION		320	7-624-104-04	STOP RING 2.0, TYPE -E	
				321	4-931-442-01	ROLLER (S2)	

5-8. DATM BLOCK ASSEMBLY-3

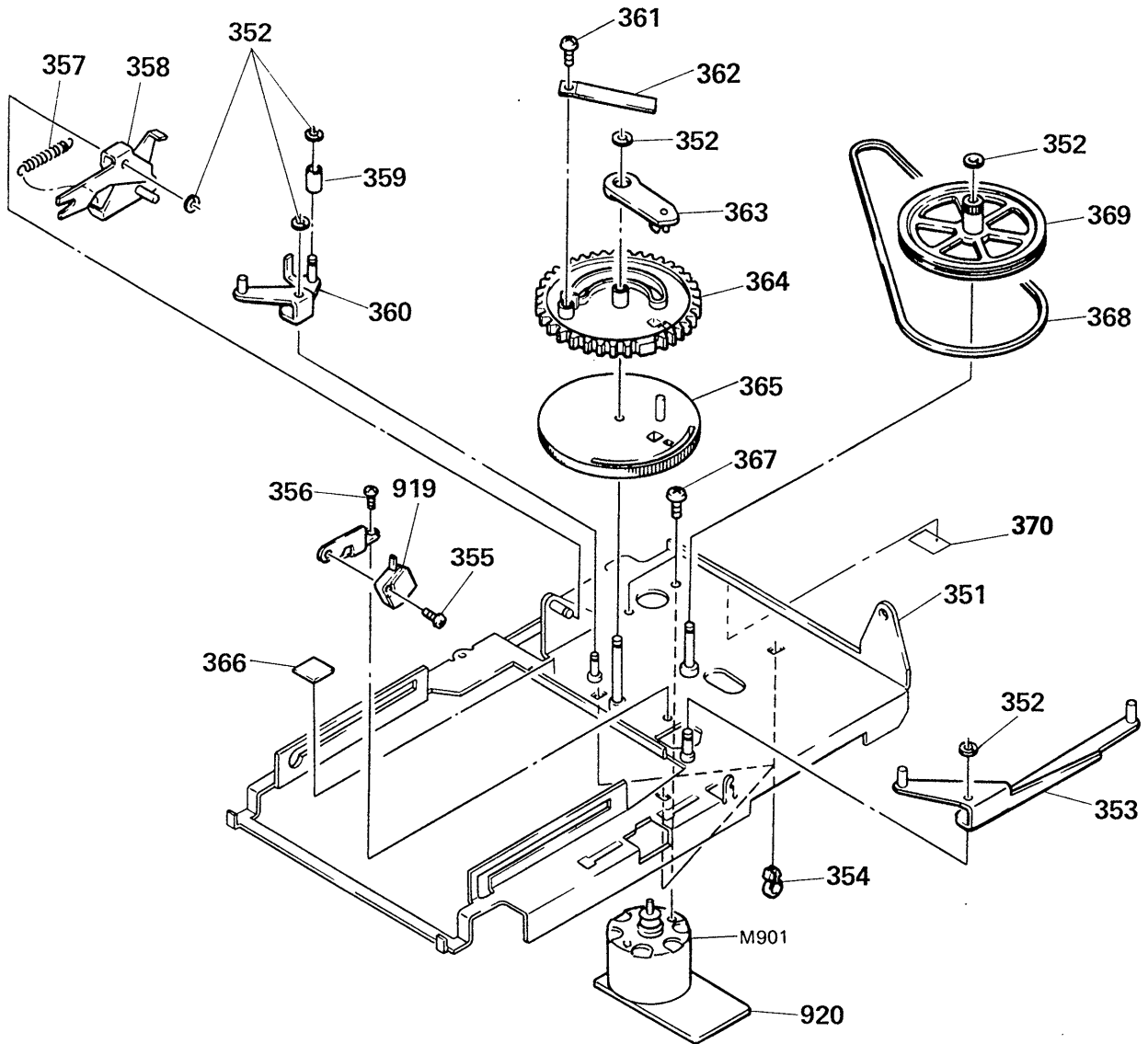

No.	Part No.	Description	Remarks	No.	Part No.	Description	Remarks
351	*X-4919-011-1	CHASSIS ASSY		363	4-923-769-01	LEVER (G)	
352	3-325-290-21	WASHER, STOPPER		364	4-923-767-02	GEAR (U)	
353	X-4919-010-1	LEVER (LC) ASSY		365	4-923-783-01	GEAR (L)	
354	3-660-815-00	CLIP, CABLE		366	3-713-907-01	SPACER, CAM	
355	7-621-255-40	SCREW +P 2X6		367	7-621-775-00	SCREW +B 2.6X3	
356	7-621-772-00	SCREW +B 2X3		368	4-925-724-01	BELT	
357	4-925-723-01	SPRING, TENSION		369	4-923-768-01	GEAR (P)	
358	X-4919-005-1	LEVER (LV) ASSY		370	3-831-441-XX	CUSHION (B), CABINET	
359	*4-923-758-01	COLLAR (LD)		919	*1-630-196-11	PC BOARD, CASSE-COM SW2	
360	X-4919-004-1	LEVER (LD) ASSY		920	*1-630-194-11	PC BOARD, CASSE-COM MOTOR	
361	7-685-531-14	SCREW +BTP 2.6X4	TYPE2 N-S	M901	A-2003-377-A	MOTOR (L) ASSY (LOADING)	
362	4-923-759-01	SPRING (G)					

5-9. MECANISM SECTION-1 (DATM-12)

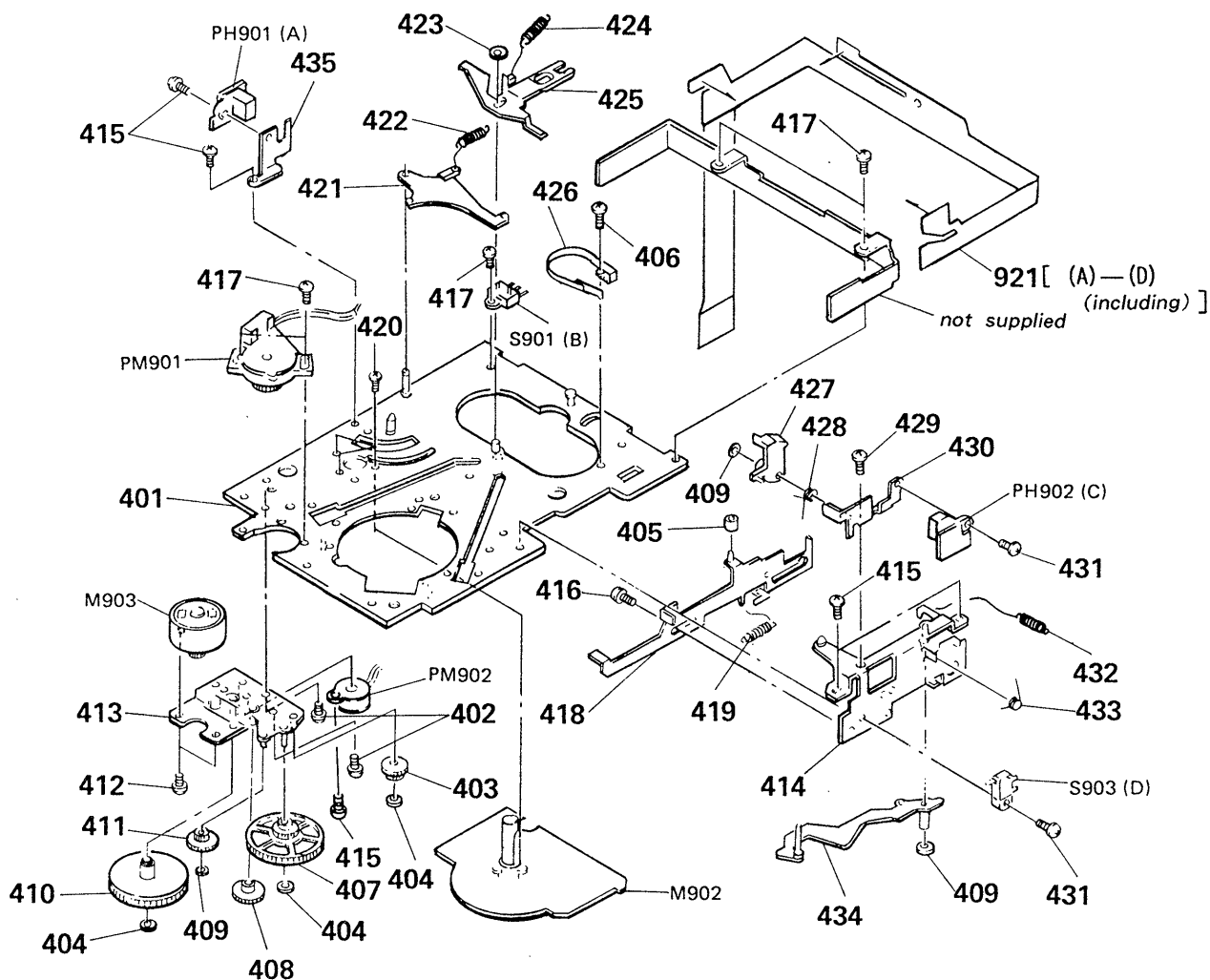

No.	Part No.	Description	Remarks	No.	Part No.	Description	Remarks
401	*X-3337-653-1	CHASSIS (MECHANICAL) ASSY		422	3-547-661-00	SPRING, TENSION	
402	7-628-253-00	SCREW +PS 2X4		423	3-321-813-01	WASHER, COTTER POLYETHYLENE	
403	3-345-182-01	GEAR (LOADING B)		424	3-570-898-00	SPRING, TENSION	
404	3-701-436-11	WASHER, 1.6 POLYETHYLENE		425	X-3337-638-1	LEVER (SLIDER) ASSY	
405	3-337-664-01	ROLLER		426	X-3337-632-1	BAND (TENSION REGULATOR) ASSY	
406	7-627-852-27	+P 1.7X3		427	3-337-608-01	OPENER, LID	
407	3-345-181-01	GEAR (LOADING A)		428	3-337-607-01	SPRING	
408	3-345-129-01	GEAR (A)		429	7-627-552-18	SCREW, PRECISION +P 1.7X1.6	
409	3-559-408-11	WASHER, POLYETHYLENE, DIA.1.2		430	*X-3337-631-1	HOLDER (E SENSOR L) ASSY	
410	X-3337-630-3	GEAR (B) ASSY		431	7-621-772-20	SCREW +B 2X5	
411	3-337-669-01	GEAR, MIDWAY		432	3-345-183-01	SPRING, TENSION	
412	7-627-553-17	SCREW, PRECISION +P 2X2		433	3-337-673-01	SPRING	
413	*X-3337-639-3	CHASSIS (CONTROL MOTOR) ASSY		434	*X-3337-629-1	LEVER (TENSION LEGULATOR) ASSY	
414	*X-3337-619-1	CHASSIS ASSY, TENSION REGULATOR		435	*3-345-119-03	HOLDER (E SENSOR RIGHT)	
415	7-621-772-08	SCREW +B 2X3		921	*1-630-197-11	PC BOARD, MD FLEXIBLE	
416	3-703-502-11	SCREW		M902	8-835-306-01	MOTOR, DC U-17A	
417	7-621-772-18	SCREW +B 2X4		PH901	1-807-698-11	PHOTO SENSOR	
418	X-3337-618-1	SLIDER ASSY, MODE		PH902	1-807-698-11	PHOTO SENSOR	
419	3-570-892-00	SPRING, TENSION		PM901	1-464-724-21	ENCODER, ROTARY	
420	7-627-552-47	SCREW, PRECISION +P 1.7X4		PM902	1-454-462-11	SOLENOID, PLUNGER	
421	3-345-145-01	LEVER (T LOCK)		S901	1-571-878-11	SWITCH, PUSH (2 KEY)	
				S903	1-570-771-11	SWITCH (LIMIT)	

5-10. MECANISM SECTION-2 (DATM-12)

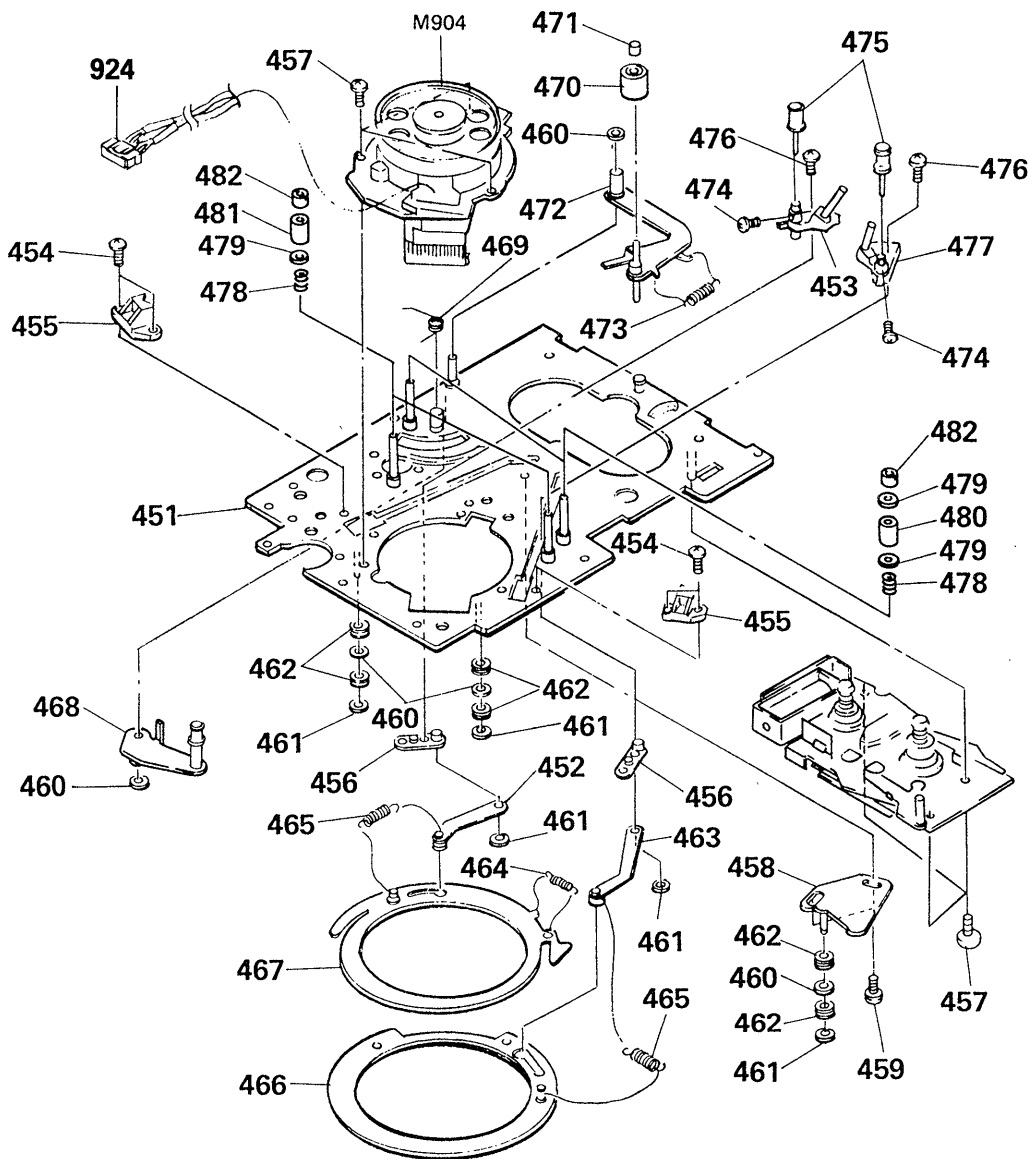

No.	Part No.	Description	Remarks	No.	Part No.	Description	Remarks
451	*X-3337-653-1	CHASSIS (MECHANICAL) ASSY		468	A-2003-408-A	LEVER (F ARM) ASSY	
452	*X-3337-603-1	ARM (RIGHT) ASSY, LOADING		469	3-337-654-01	SPRING	
453	X-3337-652-1	SLANT BLOCK (RIGHT) ASSY		470	X-3337-610-1	PINCH ROLLER ASSY	
454	7-627-852-17	+P 1.7X4		471	3-337-626-01	CAP, PINCH ROLLER	
455	*3-345-195-01	CATCHER		472	X-3337-608-1	ARM ASSY, PINCH ROLLER	
456	X-3337-604-1	PLATE ASSY, LOADING		473	3-547-659-00	SPRING, TENSION	
457	7-621-772-18	SCREW +B 2X4		474	7-627-551-17	SCREW, PRECISION +P 1.4X2	
458	*X-3337-605-1	ARM ASSY, RING ROLLER		475	X-3337-622-1	GUIDE (POM) ASSY, ROLLER	
459	7-621-772-08	SCREW +B 2X3		476	3-703-502-81	SCREW	
460	3-701-436-11	WASHER, 1.6 POLYETHYLENE		477	X-3337-651-1	SLANT BLOCK (LEFT) ASSY	
461	3-559-408-11	WASHER, POLYETHYLENE, DIA.1.2		478	3-573-470-00	SPRING, COMPRESSION	
462	3-337-622-01	ROLLER, RING		479	3-337-677-01	FLANGE	
463	*X-3337-607-1	ARM (LEFT) ASSY, LOADING		480	3-337-676-01	GUIDE, FIXED	
464	3-352-503-01	SPRING, TENSION		481	3-337-676-11	GUIDE, FIXED	
465	3-337-653-01	SPRING, TENSION		482	3-337-605-01	NUT, ADJUSTMENT	
466	X-3337-602-1	RING (LEFT) ASSY, LOADING		924	9-831-257-50	WIRE KIT	
467	X-3337-601-1	RING (RIGHT) ASSY, LOADING		M904	8-848-513-11	DRUM ASSY DOU-02D	

5-11. MECANISM SECTION-3 (DATM-12)

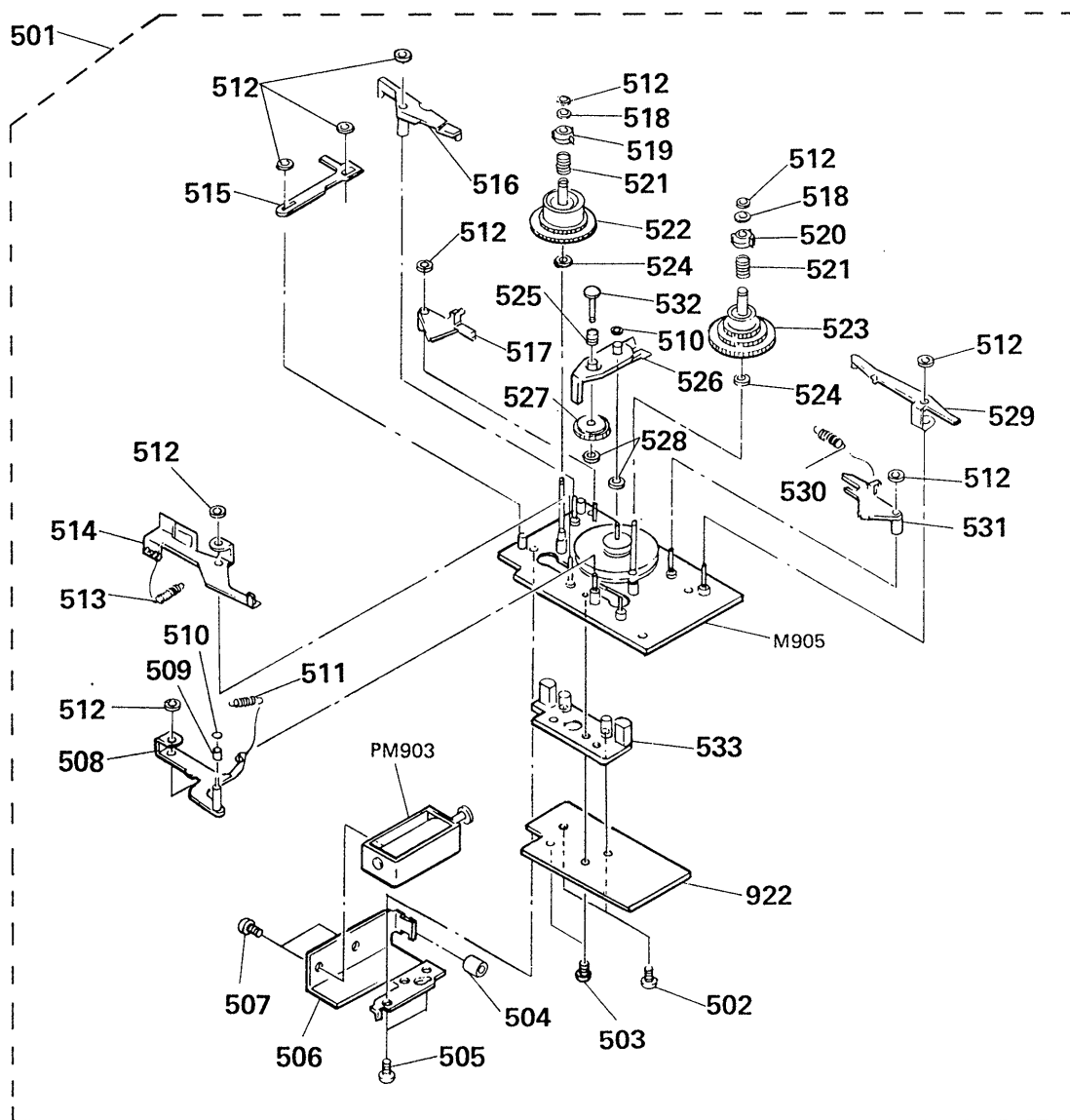

No.	Part No.	Description	Remarks	No.	Part No.	Description	Remarks
501	A-2001-355-A	CHASSIS COMPLETE ASSY, DRIVING		520	*2-623-752-01	CLAW (C) (RIGHT), REEL	
502	7-685-102-19	SCREW +P 2X4 TYPE2 SLIT		521	2-623-754-01	SPRING, COMPRESSION	
503	7-621-772-18	SCREW +B 2X4		522	X-3337-634-1	TABLE (S) ASSY, REEL	
504	*3-576-990-01	CUSHION		523	X-3337-642-1	TABLE (T) ASSY, REEL	
505	7-621-772-08	SCREW +B 2X3		524	3-701-438-11	WASHER, 2.5	
506	*3-345-118-01	BRACKET (SOLENOID)		525	3-345-115-01	SPRING, COMPRESSION	
507	7-621-775-00	SCREW +B 2.6X3		526	*3-345-113-01	LEVER (FR)	
508	*X-3337-628-1	LEVER ASSY		527	X-3337-633-1	GEAR (MIDWAY) ASSY	
509	3-345-104-01	COLLAR		528	3-701-436-11	WASHER, 1.6 POLYETHYLENE	
510	3-315-384-11	WASHER, STOPPER		529	*X-3337-637-1	LEVER (BRAKE RELEASE) ASSY	
511	3-345-169-01	SPRING, TORSION		530	3-527-190-00	SPRING, TENSION	
512	3-559-408-11	WASHER, POLYETHYLENE, DIA.1.2		531	*X-3337-636-1	LEVER (BRAKE S) ASSY	
513	3-345-168-01	SPRING, TENSION		532	*3-345-114-01	SHAFT (MIDWAY GEAR)	
514	*X-3337-640-1	LEVER (REVERSE SB) ASSY		533	*3-345-142-01	HOLDER (FG SENSOR)	
515	*3-345-166-01	LEVER (SOLENOID)		922	*1-630-185-11	PC BOARD, SENSOR	
516	3-345-110-01	LEVER (BRAKE ARM)		M905	A-2001-355-A	CHASSIS COMPLETE ASSY, DRIVING	
517	*X-3337-635-1	LEVER (BRAKE T) ASSY		PM903	1-454-482-11	SOLENOID, PLUNGER	
518	3-345-112-01	RING, RETAINING					
519	*2-623-736-01	CLAW (C) (LEFT), REEL					



## SECTION 6

### ELECTRICAL PARTS LIST

**NOTE:**

- Due to standardization, replacements in the parts list may be different from the parts specified in the diagrams or the components used on the set.
- Items marked "★" are not stocked since they are seldom required for routine service. Some delay should be anticipated when ordering these items.
- If there are two or more same circuits in a set such as a stereophonic machine, only typical circuit parts may be indicated and capacitors and resistors in other same circuits may be omitted.

**CAPACITORS:**MF:  $\mu$ F, PF:  $\mu$ F.**RESISTORS**

- All resistors are in ohms.
- F: nonflammable

**COILS**

- MMH: mH, UH:  $\mu$ H

**SEMICONDUCTORS**In each case, U:  $\mu$ , for example:UA...:  $\mu$ A..., UPA...:  $\mu$ PA...,UPC...:  $\mu$ PC, UPD...:  $\mu$ PD...

The components identified by mark or dotted line with mark are critical for safety. Replace only with part number specified.

Ref.No.	Part No.	Description	Ref.No.	Part No.	Description
901	*A-2006-080-A	MOUNTED PCB, CONTROL SW	C116	1-136-250-11	FILM 0.001MF 3% 100V
902	*1-630-193-11	PC BOARD, POWER SW	C117	1-124-918-11	ELECT 47MF 20% 63V
903	*1-630-192-11	PC BOARD, REC VOL	C118	1-130-967-00	FILM 0.0027MF 3% 100V
904	*1-630-191-11	PC BOARD, HP	C119	1-126-059-11	ELECT 10MF 20% 50V
905	1-555-795-00	CORD, POWER	C121	1-136-250-11	FILM 0.001MF 3% 100V
906	*1-630-188-11	PC BOARD, D I/O	C123	1-162-290-31	CERAMIC 470PF 10% 50V
907	*1-630-568-11	PC BORAD, TRANSISTOR	C155	1-162-284-31	CERAMIC 150PF 10% 50V
908	*1-630-567-11	PC BORAD, PIN JACK OUT	C156	1-104-240-00	POLYSTYRENE 0.001MF 5% 125V
909	*1-630-566-11	PC BORAD, PIN JACK IN	C157	1-162-199-31	CERAMIC 10PF 5% 50V
910	*A-2006-180-A	MOUNTED PCB, ANALOGUE	C159	1-123-330-00	ELECT 22MF 20% 25V
911	*1-630-190-11	PC BOARD, LPF	C161	1-124-188-00	ELECT 33MF 20% 50V
912	*A-2006-078-A	MOUNTED PCB, POWER	C170	1-136-153-00	FILM 0.01MF 5% 50V
913	*A-2006-079-A	MOUNTED PCB, SERVO	C201	1-126-101-11	ELECT 100MF 20% 10V
914	*A-2006-183-A	MOUNTED PCB, AD	C202	1-126-101-11	ELECT 100MF 20% 10V
915	*1-535-771-11	TERMINAL	C206	1-136-169-00	FILM 0.22MF 5% 50V
916	*A-2006-059-A	MOUNTED PCB, RF AMPLIFIER	C207	1-136-169-00	FILM 0.22MF 5% 50V
917	*1-630-186-11	PC BOARD, DRUM DRIVE	C208	1-136-169-00	FILM 0.22MF 5% 50V
918	*1-630-195-11	PC BOARD, CASSE-COM SW1	C209	1-136-169-00	FILM 0.22MF 5% 50V
919	*1-630-196-11	PC BOARD, CASSE-COM SW2	C210	1-136-169-00	FILM 0.22MF 5% 50V
920	*1-630-194-11	PC BOARD, CASSE-COM MOTOR	C211	1-136-169-00	FILM 0.22MF 5% 50V
921	*1-630-197-11	PC BOARD, MD FLEXIBLE	C212	1-136-169-00	FILM 0.22MF 5% 50V
922	*1-630-185-11	PC BOARD, SENSOR	C213	1-136-229-11	FILM 0.0016MF 3% 100V
923	1-533-162-00	HOLDER, FUSE	C214	1-130-892-00	FILM 0.015MF 3% 100V
924	9-831-257-50	WIRE KIT	C215	1-136-254-11	FILM 0.002MF 3% 100V
C01	1-162-851-11	CERAMIC 0.1MF 16V	C216	1-136-250-11	FILM 0.001MF 3% 100V
C101A	1-124-257-00	ELECT 2.2MF 20% 50V	C217	1-124-918-11	ELECT 47MF 20% 63V
C101	1-126-101-11	ELECT 100MF 20% 10V	C218	1-130-967-00	FILM 0.0027MF 3% 100V
C102A	1-126-157-11	ELECT 10MF 20% 16V	C219	1-126-059-11	ELECT 10MF 20% 50V
C102	1-126-101-11	ELECT 100MF 20% 10V	C221	1-136-250-11	FILM 0.001MF 3% 100V
C103A	1-164-161-11	CERAMIC CHIP 0.0022MF 10% 50V	C223	1-162-290-31	CERAMIC 470PF 10% 50V
C104A	1-163-017-00	CERAMIC CHIP 0.0047MF 10% 50V	C255	1-162-284-31	CERAMIC 150PF 10% 50V
C105A	1-164-161-11	CERAMIC CHIP 0.0022MF 10% 50V	C256	1-104-240-00	POLYSTYRENE 0.001MF 5% 125V
C106A	1-124-438-00	ELECT 1MF 20% 50V	C257	1-162-199-31	CERAMIC 10PF 5% 50V
C106	1-136-169-00	FILM 0.22MF 5% 50V	C259	1-123-330-00	ELECT 22MF 20% 25V
C107	1-136-169-00	FILM 0.22MF 5% 50V	C261	1-124-188-00	ELECT 33MF 20% 50V
C108	1-136-169-00	FILM 0.22MF 5% 50V	C270	1-136-153-00	FILM 0.01MF 5% 50V
C109	1-136-169-00	FILM 0.22MF 5% 50V	C301	1-126-129-11	ELECT 6800MF 20% 35V
C110	1-136-169-00	FILM 0.22MF 5% 50V	C302	1-126-129-11	ELECT 6800MF 20% 35V
C111	1-136-169-00	FILM 0.22MF 5% 50V	C303	1-123-333-00	ELECT 100MF 20% 25V
C112	1-136-169-00	FILM 0.22MF 5% 50V	C304	1-123-378-00	ELECT 1000MF 20% 63V
C113	1-136-229-11	FILM 0.0016MF 3% 100V	C305	1-123-378-00	ELECT 1000MF 20% 63V
C114	1-130-892-00	FILM 0.015MF 3% 100V	C312	1-126-234-11	ELECT 2200MF 20% 16V
C115	1-136-254-11	FILM 0.002MF 3% 100V	C314	1-126-234-11	ELECT 2200MF 20% 16V
			C318	1-124-130-00	ELECT 100MF 20% 63V
			C319	1-124-130-00	ELECT 100MF 20% 63V

Ref.No.	Part No.	Description						
C322	1-124-273-00	ELECT	3.3MF	20%	50V			
C323	1-124-902-00	ELECT	0.47MF	20%	50V			
C324	1-123-875-11	ELECT	10MF	20%	50V			
C325	1-124-915-11	ELECT	10MF	20%	63V			
C326	1-104-150-00	POLYSTYRENE	680PF	5%	125V			
C331	1-124-915-11	ELECT	10MF	20%	63V			
C332	1-124-915-11	ELECT	10MF	20%	63V			
C333	1-124-915-11	ELECT	10MF	20%	63V			
C334	1-124-915-11	ELECT	10MF	20%	63V			
C335	1-124-915-11	ELECT	10MF	20%	63V			
C336	1-124-915-11	ELECT	10MF	20%	63V			
C337	1-124-915-11	ELECT	10MF	20%	63V			
C338	1-124-915-11	ELECT	10MF	20%	63V			
C341	1-162-851-11	CERAMIC	0.1MF		16V			
C346	1-164-159-11	CERAMIC	0.1MF		50V			
C350	1-162-179-11	CERAMIC	0.1MF		50V			
C351	1-124-120-11	ELECT	220MF	20%	25V			
C352	1-124-120-11	ELECT	220MF	20%	25V			
C359	1-126-103-11	ELECT	470MF	20%	16V			
C360	1-126-103-11	ELECT	470MF	20%	16V			
C372	1-123-330-00	ELECT	22MF	20%	25V			
C373	1-126-103-11	ELECT	470MF	20%	16V			
C375	1-123-330-00	ELECT	22MF	20%	25V			
C376	1-162-851-11	CERAMIC	0.1MF		16V			
C377	1-162-201-31	CERAMIC	12PF	5%	50V			
C378	1-162-294-31	CERAMIC	0.001MF	10%	50V			
C379	1-161-494-00	CERAMIC	0.022MF		25V			
C380	1-162-851-11	CERAMIC	0.1MF		16V			
C388	1-162-191-31	CERAMIC	2.2PF	10%	50V			
C503	1-124-472-11	ELECT	470MF	20%	6.3V			
C504	1-124-472-11	ELECT	470MF	20%	6.3V			
C505	1-163-038-00	CERAMIC CHIP	0.1MF		25V			
C506	1-163-095-00	CERAMIC CHIP	12PF	5%	50V			
C507	1-163-095-00	CERAMIC CHIP	12PF	5%	50V			
C508	1-163-038-00	CERAMIC CHIP	0.1MF		25V			
C509	1-163-117-00	CERAMIC CHIP	100PF	5%	50V			
C510	1-163-009-11	CERAMIC CHIP	0.001MF	10%	50V			
C511	1-164-161-11	CERAMIC CHIP	0.0022MF	10%	50V			
C512	1-163-095-00	CERAMIC CHIP	12PF	5%	50V			
C513	1-163-095-00	CERAMIC CHIP	12PF	5%	50V			
C514	1-163-095-00	CERAMIC CHIP	12PF	5%	50V			
C515	1-163-095-00	CERAMIC CHIP	12PF	5%	50V			
C516	1-163-038-00	CERAMIC CHIP	0.1MF		25V			
C517	1-124-443-00	ELECT	100MF	20%	6.3V			
C518	1-163-019-00	CERAMIC CHIP	0.0068MF	10%	50V			
C519	1-163-023-00	CERAMIC CHIP	0.015MF	10%	50V			
C520	1-163-038-00	CERAMIC CHIP	0.1MF		25V			
C521	1-163-038-00	CERAMIC CHIP	0.1MF		25V			
C522	1-163-038-00	CERAMIC CHIP	0.1MF		25V			
C525	1-163-009-11	CERAMIC CHIP	0.001MF	10%	50V			
C526	1-163-009-11	CERAMIC CHIP	0.001MF	10%	50V			
C529	1-163-038-00	CERAMIC CHIP	0.1MF		25V			
C530	1-163-097-00	CERAMIC CHIP	15PF	5%	50V			
C531	1-163-038-00	CERAMIC CHIP	0.1MF		25V			
C532	1-126-233-11	ELECT	22MF	20%	25V			
C533	1-163-038-00	CERAMIC CHIP	0.1MF		25V			
C534	1-126-233-11	ELECT	22MF	20%	25V			
C535	1-124-902-00	ELECT	0.47MF	20%	50V			
C536	1-124-611-00	ELECT	1MF	20%	50V			
C537	1-163-038-00	CERAMIC CHIP	0.1MF		25V			
C538	1-126-233-11	ELECT	22MF	20%	25V			
C539	1-163-038-00	CERAMIC CHIP	0.1MF		25V			
C540	1-163-038-00	CERAMIC CHIP	0.1MF		25V			
C541	1-163-038-00	CERAMIC CHIP	0.1MF		25V			
C542	1-124-443-00	ELECT	100MF	20%	6.3V			
C543	1-162-587-91	CERAMIC CHIP	0.039MF	10%	25V			
C544	1-163-037-11	CERAMIC CHIP	0.022MF	10%	25V			
C545	1-164-161-11	CERAMIC CHIP	0.0022MF	10%	50V			
C546	1-163-117-00	CERAMIC CHIP	100PF	5%	50V			
C547	1-163-017-00	CERAMIC CHIP	0.0047MF	10%	50V			
C548	1-163-021-00	CERAMIC CHIP	0.01MF	10%	50V			
C549	1-163-021-00	CERAMIC CHIP	0.01MF	10%	50V			
C550	1-136-621-11	FILM	0.1MF	5%	50V			
C551	1-163-021-00	CERAMIC CHIP	0.01MF	10%	50V			
C552	1-136-620-11	FILM	0.047MF	5%	50V			
C553	1-123-875-11	ELECT	10MF	20%	50V			
C554	1-124-446-11	ELECT	47MF	20%	10V			
C555	1-163-038-00	CERAMIC CHIP	0.1MF		25V			
C556	1-124-443-00	ELECT	100MF	20%	6.3V			
C557	1-124-443-00	ELECT	100MF	20%	6.3V			
C559	1-164-161-11	CERAMIC CHIP	0.0022MF	10%	50V			
C560	1-163-021-00	CERAMIC CHIP	0.01MF	10%	50V			
C561	1-164-161-11	CERAMIC CHIP	0.0022MF	10%	50V			
C562	1-163-021-00	CERAMIC CHIP	0.01MF	10%	50V			
C564	1-163-038-00	CERAMIC CHIP	0.1MF		25V			
C565	1-163-037-11	CERAMIC CHIP	0.022MF	10%	25V			
C566	1-124-443-00	ELECT	100MF	20%	6.3V			
C567	1-163-009-11	CERAMIC CHIP	0.001MF	10%	50V			
C569	1-163-019-00	CERAMIC CHIP	0.0068MF	10%	50V			
C570	1-163-021-00	CERAMIC CHIP	0.01MF	10%	50V			
C571	1-163-037-11	CERAMIC CHIP	0.022MF	10%	25V			
C572	1-163-037-11	CERAMIC CHIP	0.022MF	10%	25V			
C573	1-163-037-11	CERAMIC CHIP	0.022MF	10%	25V			
C574	1-163-009-11	CERAMIC CHIP	0.001MF	10%	50V			
C575	1-163-021-00	CERAMIC CHIP	0.01MF	10%	50V			
C576	1-163-021-00	CERAMIC CHIP	0.01MF	10%	50V			
C577	1-163-005-11	CERAMIC CHIP	470PF	10%	50V			
C578	1-163-017-00	CERAMIC CHIP	0.0047MF	10%	50V			
C579	1-123-875-11	ELECT	10MF	20%	50V			
C580	1-163-038-00	CERAMIC CHIP	0.1MF		25V			
C581	1-163-809-11	CERAMIC CHIP	0.047MF	10%	25V			
C582	1-124-443-00	ELECT	100MF	20%	6.3V			
C583	1-163-037-11	CERAMIC CHIP	0.022MF	10%	25V			
C584	1-163-021-00	CERAMIC CHIP	0.01MF	10%	50V			
C585	1-123-875-11	ELECT	10MF	20%	50V			
C586	1-163-009-11	CERAMIC CHIP	0.001MF	10%	50V			
C587	1-123-875-11	ELECT	10MF	20%	50V			
C592	1-124-925-11	ELECT	2.2MF	20%	50V			
C670	1-163-038-00	CERAMIC CHIP	0.1MF		25V			
C701	1-124-443-00	ELECT	100MF	20%	10V			
C801	1-124-482-11	ELECT	33MF	20%	25V			
C802	1-130-487-00	MYLAR	0.022MF	5%	50V			
C803	1-162-179-11	CERAMIC	0.1MF		50V			
C804	1-162-179-11	CERAMIC	0.1MF		50V			
C805	1-130-487-00	MYLAR	0.022MF	5%	50V			
C806	1-124-482-11	ELECT	33MF	20%	25V			

Ref.No.	Part No.	Description							
C807	1-162-211-31	CERAMIC	33PF	5%	50V				
C808	1-162-179-11	CERAMIC	0.1MF		50V				
C809	1-162-179-11	CERAMIC	0.1MF		50V				
C810	1-124-477-11	ELECT	47MF	20%	25V				
C811	1-124-477-11	ELECT	47MF	20%	25V				
C812	1-162-179-11	CERAMIC	0.1MF		50V				
C813	1-136-153-00	FILM	0.01MF	5%	50V				
C814	1-136-165-00	FILM	0.1MF	5%	50V				
C901	1-123-875-11	ELECT	10MF	20%	50V				
C903	1-124-887-00	ELECT	3300MF	20%	16V				
C905	1-124-887-00	ELECT	3300MF	20%	16V				
C906	1-124-473-11	ELECT	1000MF	20%	10V				
C907	1-124-473-11	ELECT	1000MF	20%	10V				
C908	1-124-556-11	ELECT	2200MF	20%	16V				
C909	1-126-017-11	ELECT	6800MF	20%	16V				
C910	1-124-927-11	ELECT	4.7MF	20%	50V				
C911	1-124-927-11	ELECT	4.7MF	20%	50V				
C912	1-161-494-00	CERAMIC	0.022MF		25V				
C913	1-124-559-51	ELECT	1000MF	20%	10V				
C914	1-126-234-11	ELECT	2200MF	20%	10V				
C915	1-124-484-11	ELECT	220MF	20%	35V				
C916	1-124-911-11	ELECT	220MF	20%	50V				
C917	1-124-122-11	ELECT	100MF	20%	35V				
C918	1-136-165-00	FILM	0.1MF	5%	50V				
C919	1-136-177-00	FILM	1MF	5%	50V				
C920	△1-161-742-00	CERAMIC	0.0022MF	20%	400V				
C921	△1-161-742-00	CERAMIC	0.0022MF	20%	400V				
C922	△1-161-742-00	CERAMIC	0.0022MF	20%	400V				
C923	1-161-742-00	CERAMIC	0.0022MF	20%	400V				
C925	1-136-165-00	FILM	0.1MF	5%	50V				
C951	1-163-038-00	CERAMIC CHIP	0.1MF		25V				
C953	1-163-038-00	CERAMIC CHIP	0.1MF		25V				
C954	1-163-005-11	CERAMIC CHIP	470PF	10%	50V				
C955	1-164-005-11	CERAMIC CHIP	0.47MF		25V				
C956	1-124-778-00	ELECT CHIP	22MF	20%	6.3V				
C957	1-163-038-00	CERAMIC CHIP	0.1MF		25V				
C958	1-163-005-11	CERAMIC CHIP	470PF	10%	50V				
C959	1-163-005-11	CERAMIC CHIP	470PF	10%	50V				
C960	1-163-011-11	CERAMIC CHIP	0.0015MF	10%	50V				
C961	1-163-021-00	CERAMIC CHIP	0.01MF	10%	50V				
C962	1-163-818-00	CERAMIC CHIP	0.1MF	10%	50V				
C963	1-163-021-00	CERAMIC CHIP	0.01MF	10%	50V				
C964	1-163-809-11	CERAMIC CHIP	0.047MF	10%	25V				
C965	1-163-077-00	CERAMIC CHIP	0.1MF	10%	25V				
C966	1-163-038-00	CERAMIC CHIP	0.1MF		25V				
C967	1-124-778-00	ELECT CHIP	22MF	20%	6.3V				
C968	1-163-038-00	CERAMIC CHIP	0.1MF		25V				
C969	1-164-005-11	CERAMIC CHIP	0.47MF		25V				
C971	1-163-077-00	CERAMIC CHIP	0.1MF	10%	25V				
C972	1-163-809-11	CERAMIC CHIP	0.047MF	10%	25V				
C973	1-163-021-00	CERAMIC CHIP	0.01MF	10%	50V				
C974	1-163-818-00	CERAMIC CHIP	0.1MF	10%	50V				
C975	1-163-021-00	CERAMIC CHIP	0.01MF	10%	50V				
C976	1-163-011-11	CERAMIC CHIP	0.0015MF	10%	50V				
C977	1-163-020-00	CERAMIC CHIP	0.0082MF	10%	50V				
C978	1-135-091-00	TANTAL. CHIP	1MF	10%	16V				
C979	1-163-020-00	CERAMIC CHIP	0.0082MF	10%	50V				
C980	1-163-809-11	CERAMIC CHIP	0.047MF	10%	25V				
C981	1-163-809-11	CERAMIC CHIP	0.047MF	10%	25V				
C982	1-163-005-11	CERAMIC CHIP	470PF	10%	50V				
C983	1-163-021-00	CERAMIC CHIP	0.01MF	10%	50V				
C984	1-163-005-11	CERAMIC CHIP	470PF	10%	50V				
C985	1-163-005-11	CERAMIC CHIP	470PF	10%	50V				
CN01	*1-564-336-00	PIN, CONNECTOR	2P						
CN02	*1-564-336-61	PIN, CONNECTOR	2P						
CN03	*1-564-498-11	PIN, CONNECTOR	5P						
CN011	*1-564-505-11	PLUG, CONNECTOR	2P						
CN021	*1-564-505-11	PLUG, CONNECTOR	2P						
CN101A	*1-564-726-11	PIN, CONNECTOR (SMALL TYPE)	10P						
CN102A	1-568-369-11	HOUSING, CONNECTOR (PC BOARD)	8P						
CN103A	*1-564-720-11	PIN, CONNECTOR (SMALL TYPE)	4P						
CN231	*1-564-508-11	PLUG, CONNECTOR	5P						
CN232	*1-564-505-11	PLUG, CONNECTOR	2P						
CN332	*1-564-507-11	PLUG, CONNECTOR	4P						
CN351	*1-564-709-11	PIN, CONNECTOR (SMALL TYPE)	7P						
CN352	*1-564-706-11	PIN, CONNECTOR (SMALL TYPE)	4P						
CN371	*1-564-507-11	PLUG, CONNECTOR	4P						
CN372	*1-564-507-11	PLUG, CONNECTOR	4P						
CN373	*1-564-507-11	PLUG, CONNECTOR	4P						
CN374	*1-564-507-11	PLUG, CONNECTOR	4P						
CN391	*1-564-506-11	PLUG, CONNECTOR	3P						
CN392	*1-564-338-00	PIN, CONNECTOR	4P						
CN393	*1-564-518-11	PLUG, CONNECTOR	3P						
CN501	*1-564-339-61	PIN, CONNECTOR	5P						
CN502	1-565-849-11	SOCKET, CONNECTOR	11P						
CN503	*1-564-710-11	PIN, CONNECTOR (SMALL TYPE)	8P						
CN531	*1-564-709-11	PIN, CONNECTOR (SMALL TYPE)	7P						
CN532	*1-564-706-11	PIN, CONNECTOR (SMALL TYPE)	4P						
CN533	*1-564-507-11	PLUG, CONNECTOR	4P						
CN534	*1-564-337-00	PIN, CONNECTOR	3P						
CN541	*1-564-713-11	PIN, CONNECTOR (SMALL TYPE)	11P						
CN542	*1-564-708-11	PIN, CONNECTOR (SMALL TYPE)	6P						
CN555	*1-564-514-11	PLUG, CONNECTOR	11P						
CN571	*1-564-708-11	PIN, CONNECTOR (SMALL TYPE)	6P						
CN575	*1-564-707-11	PIN, CONNECTOR (SMALL TYPE)	5P						
CN581	*1-564-712-11	PIN, CONNECTOR (SMALL TYPE)	10P						
CN582	*1-564-707-11	PIN, CONNECTOR (SMALL TYPE)	5P						
CN583	*1-564-704-11	PIN, CONNECTOR (SMALL TYPE)	2P						
CN584	*1-564-704-11	PIN, CONNECTOR (SMALL TYPE)	2P						
CN585	*1-564-706-31	PIN, CONNECTOR (SMALL TYPE)	4P						
CN591	*1-564-510-11	PLUG, CONNECTOR	7P						
CN751	*1-564-722-11	PIN, CONNECTOR (SMALL TYPE)	6P						
CN755	*1-564-721-11	PIN, CONNECTOR (SMALL TYPE)	5P						
CN951	*1-564-722-11	PIN, CONNECTOR (SMALL TYPE)	6P						
CN952	1-564-729-11	PIN, CONNECTOR (SMALL TYPE)	13P						
CN971	*1-564-342-11	PIN, CONNECTOR	8P						
CP501	1-233-136-11	COMPOSITION CIRCUIT BLOCK							
CP502	1-236-114-11	RES. NETWORK							
CP503	1-233-134-11	COMPOSITION CIRCUIT BLOCK							
CP504	1-233-136-11	COMPOSITION CIRCUIT BLOCK							
CP505	1-233-133-11	COMPOSITION CIRCUIT BLOCK							
CP506	1-233-135-11	COMPOSITION CIRCUIT BLOCK							
CP801	1-464-931-11	RECEIVE UNIT, RAY							
CP802	1-464-878-11	TRANSMITTER UNIT, RAY							

Note: The components identified by mark △ or dotted line with mark △ are critical for safety. Replace only with part number specified.

Ref.No.	Part No.	Description
D151	8-719-107-94	DIODE 1SS202-1
D152	8-719-107-94	DIODE 1SS202-1
D251	8-719-107-94	DIODE 1SS202-1
D252	8-719-107-94	DIODE 1SS202-1
D301	8-719-230-02	DIODE 30D2-FC
D302	8-719-230-02	DIODE 30D2-FC
D303	8-719-230-02	DIODE 30D2-FC
D304	8-719-230-02	DIODE 30D2-FC
D305	8-719-910-75	DIODE HZ7B2L
D306	8-719-107-94	DIODE 1SS202-1
D307	8-719-107-94	DIODE 1SS202-1
D308	8-719-107-94	DIODE 1SS202-1
D309	8-719-200-82	DIODE 11ES2
D310	8-719-107-94	DIODE 1SS202-1
D350	8-719-200-82	DIODE 11ES2
D501	8-719-100-05	DIODE 1S2837
D502	8-719-100-05	DIODE 1S2837
D503	8-719-200-82	DIODE 11ES2
D504	8-719-200-82	DIODE 11ES2
D505	8-719-100-05	DIODE 1S2837
D506	8-719-100-05	DIODE 1S2837
D507	8-719-200-82	DIODE 11ES2
D550	8-719-100-05	DIODE 1S2837
D551	8-719-100-05	DIODE 1S2837
D670	8-719-100-05	DIODE 1S2837
D901	8-719-200-82	DIODE 11ES2
D902	8-719-200-82	DIODE 11ES2
D903	8-719-107-94	DIODE 1SS202-1
D904	8-719-200-77	DIODE 10E2N
D905	8-719-200-77	DIODE 10E2N
D907	8-719-200-77	DIODE 10E2N
D908	8-719-200-77	DIODE 10E2N
D909	8-719-230-02	DIODE 30DF2
D910	8-719-200-82	DIODE 11ES2
D911	8-719-200-82	DIODE 11ES2
D912	8-719-200-82	DIODE 11ES2
D913	8-719-933-33	DIODE HZS6A1L
D914	8-719-107-94	DIODE 1SS202-1
D915	8-719-107-94	DIODE 1SS202-1
D916	8-719-504-60	DIODE S4VB60
D917	8-719-933-33	DIODE HZS6A1L
F901	△ 1-532-286-00	FUSE, TIME-LAG (2.5A)
F902	△ 1-532-286-00	FUSE, TIME-LAG (2.5A)
FL701	1-519-472-11	INDICATOR TUBE, FLUORESCENT
FR301	△ 1-212-857-00	FUSIBLE 10 5% 1/4W F
FR302	△ 1-212-857-00	FUSIBLE 10 5% 1/4W F
FR901	△ 1-212-865-00	FUSIBLE 22 5% 1/4W F
FR902	△ 1-212-946-00	FUSIBLE 3.3 5% 1/2W F
IC11	8-759-013-22	IC LM358M
IC101	8-759-107-68	IC CX20115A
IC102	8-759-013-22	IC LM358M
IC307	8-759-933-62	IC SAA7220P
IC308	8-759-973-09	IC TDA1541A
IC309	8-759-602-83	IC M5238P
IC310	8-759-981-98	IC RC4560DD
IC312	8-759-900-72	IC NE5532P
IC315	8-759-900-72	IC NE5532P

Ref.No.	Part No.	Description
IC316	8-759-900-72	IC NE5532P
IC317	8-759-604-99	IC M5F78M06
IC318	8-759-604-41	IC M5F79M05
IC319	8-759-604-94	IC M5F79M06
IC351	8-759-209-85	IC CXA1099S
IC501	8-752-331-00	IC CXK5864BM-12L
IC502	8-752-331-00	IC CXK5864BM-12L
IC503	8-759-933-85	IC CXD1009Q
IC504	8-759-933-84	IC CXD1008Q
IC505	8-759-030-18	IC TL072CM
IC506	8-759-030-18	IC TL072CM
IC507	8-752-810-67	IC CXP5048H-191Q
IC508	8-759-947-57	IC CXD1136Q
IC509	8-759-945-98	IC CXD1146Q
IC510	8-759-931-43	IC SN74LS624NS
IC511	8-752-306-51	IC CX23065A
IC512	8-759-009-10	IC MC14069UBF
IC513	8-759-141-69	IC UPD75104GF-704-3B
IC514	8-759-230-34	IC TMP47C460AF-9473
IC515	8-759-821-15	IC LC9108B-235
IC516	8-759-946-81	IC CXD1052Q-Z
IC517	8-759-030-06	IC LM324M
IC518	8-759-932-54	IC BV4066BF
IC519	8-759-909-45	IC CX20084
IC520	8-759-013-22	IC LM358M
IC521	8-759-030-03	IC LM393M
IC522	8-759-908-81	IC MB3763PF
IC523	8-752-030-63	IC CXA1046M
IC524	8-759-030-61	IC TL431CM
IC525	8-759-030-06	IC LM324M
IC550	8-759-031-84	IC SC7S04F
IC701	8-752-807-08	IC CXP5058H-624Q
IC702	8-759-971-44	IC MSM74H010GS-K
IC703	8-749-920-59	IC A1QH3020S
IC801	8-759-202-13	IC TC74HCV04P
IC802	8-759-202-11	IC TC74HC00P
IC803	8-759-202-13	IC TC74HCV04P
IC804	8-759-601-02	IC M5218P
IC901	8-759-630-21	IC M5290P-16
IC902	8-759-600-02	IC M5218L
IC951	8-752-032-26	IC CXA1045Q-Z
J301	1-565-319-71	JACK, PIN 2P (LINE IN)
J302	1-565-319-71	JACK, PIN 2P (LINE OUT)
J304	1-565-327-11	JACK, LARGE TYPE 1P (HEADPHONES)
J801	1-565-319-61	JACK, PIN 2P (COAXIAL)
JW11	1-216-295-00	METAL GLAZE 0 5% 1/10W
JW12	1-216-295-00	METAL GLAZE 0 5% 1/10W
JW101	1-216-296-00	METAL GLAZE 0 5% 1/8W
JW102	1-216-296-00	METAL GLAZE 0 5% 1/8W
JW103	1-216-296-00	METAL GLAZE 0 5% 1/8W
JW104	1-216-296-00	METAL GLAZE 0 5% 1/8W
JW105	1-216-296-00	METAL GLAZE 0 5% 1/8W
JW106	1-216-296-00	METAL GLAZE 0 5% 1/8W
JW107	1-216-296-00	METAL GLAZE 0 5% 1/8W
JW108	1-216-296-00	METAL GLAZE 0 5% 1/8W
JW109	1-216-296-00	METAL GLAZE 0 5% 1/8W
JW110	1-216-296-00	METAL GLAZE 0 5% 1/8W

**Note:** The components identified by mark △ or dotted line with mark △ are critical for safety. Replace only with part number specified.

Ref.No.	Part No.	Description			
JW111	1-216-296-00	METAL GLAZE	0	5%	1/8W
JW112	1-216-295-00	METAL GLAZE	0	5%	1/10W
JW113	1-216-295-00	METAL GLAZE	0	5%	1/10W
L351	1-408-024-00	INDUCTOR	0.22UH		
L501	1-407-182-XX	INDUCTOR	2.2UH		
L502	1-408-777-00	INDUCTOR CHIP	10UH		
L503	1-408-777-00	INDUCTOR CHIP	10UH		
L504	1-408-793-21	INDUCTOR CHIP	220UH		
L801	1-408-072-00	INDUCTOR	47UH		
L901	△ 1-424-051-11	COIL, LINE FILTER			
L951	1-408-777-00	INDUCTOR CHIP	10UH		
L952	1-408-791-00	INDUCTOR CHIP	150UH		
L953	1-408-791-00	INDUCTOR CHIP	150UH		
LPF101	1-236-152-11	FILTER UNIT, LOW PASS			
LPF201	1-236-152-11	FILTER UNIT, LOW PASS			
M501	A-2001-355-A	CHASSIS COMPLETE ASSY, DRIVING			
M901	A-2003-377-A	MOTOR (L) ASSY (LOADING)			
M902	8-835-306-01	MOTOR, DC U-17A			
M904	8-848-513-11	DRUM ASSY DOU-02D			
M905	A-2001-355-A	CHASSIS COMPLETE ASSY, DRIVING			
PH11	8-719-751-42	DIODE NJL5141E-AA			
PH21	8-719-751-42	DIODE NJL5141E-AA			
PH901	1-807-698-11	PHOTO SENSOR			
PH902	1-807-698-11	PHOTO SENSOR			
PM901	1-464-724-21	ENCODER, ROTARY			
PM902	1-454-462-11	SOLENOID, PLUNGER			
PM903	1-454-482-11	SOLENOID, PLUNGER			
Q11	8-729-216-22	TRANSISTOR 2SA1162			
Q21	8-729-216-22	TRANSISTOR 2SA1162			
Q101A	8-729-901-00	TRANSISTOR DTC124EK			
Q101	8-729-107-84	TRANSISTOR 2SC3623AL			
Q102A	8-729-100-66	TRANSISTOR 2SC1623			
Q102	8-729-107-84	TRANSISTOR 2SC3623AL			
Q103A	8-729-101-07	TRANSISTOR 2SB798			
Q201	8-729-107-84	TRANSISTOR 2SC3623AL			
Q202	8-729-107-84	TRANSISTOR 2SC3623AL			
Q305	8-729-900-61	TRANSISTOR DTA114ES			
Q306	8-729-900-61	TRANSISTOR DTA114ES			
Q307	8-729-900-61	TRANSISTOR DTA114ES			
Q308	8-729-119-78	TRANSISTOR 2SC2785HFE			
Q309	8-729-119-76	TRANSISTOR 2SA1175HFE			
Q310	8-729-911-61	TRANSISTOR DTA114ES			
Q311	8-729-203-02	TRANSISTOR 2SK30A-0			
Q312	8-729-203-02	TRANSISTOR 2SK30A-0			
Q313	8-729-107-84	TRANSISTOR 2SC3623AL			
Q314	8-729-127-53	TRANSISTOR 2SC2275-P			
Q315	8-729-167-62	TRANSISTOR 2SC2676			
Q316	8-729-113-82	TRANSISTOR 2SA1138			
Q317	8-729-110-68	TRANSISTOR 2SA1409L			
Q318	8-729-190-53	TRANSISTOR 2SA985A-P			
Q501	8-729-100-66	TRANSISTOR 2SC1623			
Q502	8-729-162-22	TRANSISTOR 2SA1162			
Q503	8-729-901-00	TRANSISTOR DTC124EK			
Q504	8-729-403-02	TRANSISTOR XN4212			
Q506	8-729-403-02	TRANSISTOR XN4212			
Q507	8-729-906-83	TRANSISTOR 2SB1181F5			
Q508	8-729-906-83	TRANSISTOR 2SB1181F5			

Ref.No.	Part No.	Description			
Q509	8-729-100-66	TRANSISTOR 2SC1623			
Q510	8-729-403-38	TRANSISTOR XN4116			
Q511	8-729-901-05	TRANSISTOR DTA124EK			
Q512	8-729-403-02	TRANSISTOR XN4212			
Q513	8-729-805-25	TRANSISTOR 2SB1121			
Q514	8-729-807-16	TRANSISTOR 2SD1621			
Q515	8-729-403-02	TRANSISTOR XN4212			
Q516	8-729-101-07	TRANSISTOR 2SB798			
Q518	8-729-901-05	TRANSISTOR DTA124EK			
Q519	8-729-140-75	TRANSISTOR 2SD999			
Q520	8-729-100-66	TRANSISTOR 2SC1623			
Q521	8-729-901-00	TRANSISTOR DTC124EK			
Q523	8-729-402-99	TRANSISTOR XN4112			
Q530	8-729-901-05	TRANSISTOR DTA124EK			
Q550	8-729-100-66	TRANSISTOR 2SC1623			
Q670	8-729-107-42	TRANSISTOR 2SC3624L17			
Q671	8-729-901-05	TRANSISTOR DTA124EK			
Q702	8-729-119-78	TRANSISTOR 2SC2785-HFE			
Q703	8-729-119-78	TRANSISTOR 2SC2785-HFE			
Q704	8-729-119-78	TRANSISTOR 2SC2785-HFE			
Q705	8-729-119-78	TRANSISTOR 2SC2785-HFE			
Q706	8-729-119-78	TRANSISTOR 2SC2785-HFE			
Q901	8-729-808-76	TRANSISTOR 2SD1913SA			
Q902	8-729-808-72	TRANSISTOR 2SB1274SA-Q			
Q903	8-729-808-76	TRANSISTOR 2SD1913SA			
Q904	8-729-808-72	TRANSISTOR 2SB1274SA-Q			
Q905	8-729-900-61	TRANSISTOR DTA114ES			
Q906	8-729-900-61	TRANSISTOR DTA114ES			
Q907	8-729-110-68	TRANSISTOR 2SA1409L			
Q908	8-729-173-13	TRANSISTOR 2SB731-F			
R11	1-216-041-00	METAL GLAZE	470	5%	1/10W
R12	1-216-081-00	METAL GLAZE	22K	5%	1/10W
R13	1-216-073-00	METAL GLAZE	10K	5%	1/10W
R14	1-216-103-00	METAL GLAZE	180K	5%	1/10W
R15	1-216-057-00	METAL GLAZE	2.2K	5%	1/10W
R16	1-216-077-00	METAL GLAZE	15K	5%	1/10W
R17	1-216-067-00	METAL GLAZE	5.6K	5%	1/10W
R21	1-216-041-00	METAL GLAZE	470	5%	1/10W
R22	1-216-081-00	METAL GLAZE	22K	5%	1/10W
R23	1-216-073-00	METAL GLAZE	10K	5%	1/10W
R24	1-216-103-00	METAL GLAZE	180K	5%	1/10W
R25	1-216-057-00	METAL GLAZE	2.2K	5%	1/10W
R101A	1-216-061-00	METAL GLAZE	3.3K	5%	1/10W
R101	1-246-545-00	CARBON	1M	5%	1/4W
R102A	1-216-075-00	METAL GLAZE	12K	5%	1/10W
R102	1-247-704-11	CARBON	220	5%	1/4W
R103A	1-216-029-00	METAL GLAZE	150	5%	1/10W
R103	1-247-721-11	CARBON	4.7K	5%	1/4W
R104A	1-216-058-00	METAL GLAZE	2.4K	5%	1/10W
R104	1-249-590-11	CARBON	39K	5%	1/4W
R105A	1-216-057-00	METAL GLAZE	2.2K	5%	1/10W
R106A	1-216-084-00	METAL GLAZE	30K	5%	1/10W
R106	1-247-721-11	CARBON	4.7K	5%	1/4W
R107A	1-216-073-00	METAL GLAZE	10K	5%	1/10W
R107	1-247-721-11	CARBON	4.7K	5%	1/4W

Note: The components identified by mark △ or dotted line with mark △ are critical for safety. Replace only with part number specified.

Ref.No.	Part No.	Description			
R108A	1-216-073-00	METAL GLAZE	10K	5%	1/10W
R109A	1-216-073-00	METAL GLAZE	10K	5%	1/10W
R110A	1-216-089-00	METAL GLAZE	47K	5%	1/10W
R111A	1-216-073-00	METAL GLAZE	10K	5%	1/10W
R112A	1-216-049-00	METAL GLAZE	1K	5%	1/10W
R112	1-247-716-11	CARBON	1.8K	5%	1/4W
R113A	1-216-025-00	METAL GLAZE	100	5%	1/10W
R113	1-247-716-11	CARBON	1.8K	5%	1/4W
R114	1-249-429-11	CARBON	10K	5%	1/4W
R115	1-246-545-00	CARBON	1M	5%	1/4W
R116	1-247-713-11	CARBON	1K	5%	1/4W
R117	1-247-716-11	CARBON	1.8K	5%	1/4W
R118	1-249-469-11	CARBON	100K	5%	1/4W
R119	1-249-657-11	CARBON	220	5%	1/2W
R121	1-249-469-11	CARBON	100K	5%	1/4W
R122	1-249-497-11	CARBON	33K	5%	1/4W
R123	1-247-721-11	CARBON	4.7K	5%	1/4W
R124	1-249-462-11	CARBON	22K	5%	1/4W
R125	1-247-704-11	CARBON	220	5%	1/4W
R126	1-247-152-00	CARBON	8.2K	5%	1/4W
R127	1-249-586-11	CARBON	27K	5%	1/4W
R128	1-249-657-11	CARBON	220	5%	1/2W
R131	1-249-425-11	CARBON	4.7K	5%	1/4W
R162	1-247-721-11	CARBON	4.7K	5%	1/4W
R163	1-247-721-11	CARBON	4.7K	5%	1/4W
R164	1-247-717-11	CARBON	2.2K	5%	1/4W
R165	1-249-542-11	CARBON	390	5%	1/4W
R166	1-247-714-11	CARBON	1.2K	5%	1/4W
R167	1-247-708-11	CARBON	470	5%	1/4W
R168	1-247-718-11	CARBON	2.7K	5%	1/4W
R169	1-249-438-11	CARBON	56K	5%	1/4W
R170	1-249-469-11	CARBON	100K	5%	1/4W
R184	1-247-152-00	CARBON	7.5K	5%	1/4W
R185	1-249-417-11	CARBON	1K	5%	1/4W
R201	1-246-545-00	CARBON	1M	5%	1/4W
R202	1-247-704-11	CARBON	220	5%	1/4W
R203	1-247-721-11	CARBON	4.7K	5%	1/4W
R204	1-249-590-11	CARBON	39K	5%	1/4W
R206	1-247-721-11	CARBON	4.7K	5%	1/4W
R207	1-247-721-11	CARBON	4.7K	5%	1/4W
R212	1-247-716-11	CARBON	1.8K	5%	1/4W
R213	1-247-716-11	CARBON	1.8K	5%	1/4W
R214	1-249-429-11	CARBON	10K	5%	1/4W
R215	1-246-545-00	CARBON	1M	5%	1/4W
R216	1-247-713-11	CARBON	1K	5%	1/4W
R217	1-247-716-11	CARBON	1.8K	5%	1/4W
R218	1-249-469-11	CARBON	100K	5%	1/4W
R219	1-249-657-11	CARBON	220	5%	1/2W
R221	1-249-469-11	CARBON	100K	5%	1/4W
R222	1-249-497-11	CARBON	33K	5%	1/4W
R223	1-247-721-11	CARBON	4.7K	5%	1/4W
R224	1-249-462-11	CARBON	22K	5%	1/4W
R225	1-247-704-11	CARBON	220	5%	1/4W
R226	1-247-152-00	CARBON	8.2K	5%	1/4W
R227	1-249-586-11	CARBON	27K	5%	1/4W
R228	1-249-657-11	CARBON	220	5%	1/2W

Ref.No.	Part No.	Description			
R231	1-249-425-11	CARBON	4.7K	5%	1/4W
R262	1-247-721-11	CARBON	4.7K	5%	1/4W
R263	1-247-721-11	CARBON	4.7K	5%	1/4W
R264	1-247-717-11	CARBON	2.2K	5%	1/4W
R265	1-249-542-11	CARBON	390	5%	1/4W
R266	1-247-714-11	CARBON	1.2K	5%	1/4W
R267	1-247-708-11	CARBON	470	5%	1/4W
R268	1-247-718-11	CARBON	2.7K	5%	1/4W
R269	1-249-438-11	CARBON	56K	5%	1/4W
R270	1-249-469-11	CARBON	100K	5%	1/4W
R284	1-247-152-00	CARBON	7.5K	5%	1/4W
R285	1-249-417-11	CARBON	1K	5%	1/4W
R319	1-249-441-11	CARBON	100K	5%	1/4W
R320	1-247-804-11	CARBON	75	5%	1/4W
R323	1-249-437-11	CARBON	47K	5%	1/4W
R324	1-249-417-11	CARBON	1K	5%	1/4W
R325	1-249-419-11	CARBON	1.5K	5%	1/4W
R326	1-247-883-00	CARBON	150K	5%	1/4W
R327	1-249-427-11	CARBON	6.8K	5%	1/4W
R328	1-249-429-11	CARBON	10K	5%	1/4W
R329	1-249-421-11	CARBON	2.2K	5%	1/4W
R330	1-249-417-11	CARBON	1K	5%	1/4W
R331	1-249-424-11	CARBON	3.9K	5%	1/4W
R332	1-247-704-11	CARBON	220	5%	1/4W
R333	1-247-704-11	CARBON	220	5%	1/4W
R334	1-247-713-11	CARBON	1K	5%	1/4W
R335	1-249-466-11	CARBON	56K	5%	1/4W
R336	1-249-802-11	CARBON	1K	1%	1/2W
R337	1-249-802-11	CARBON	1K	1%	1/2W
R338	1-249-810-11	CARBON	2.2K	1%	1/2W
R339	1-249-810-11	CARBON	2.2K	1%	1/2W
R340	1-247-717-11	CARBON	2.2K	5%	1/4W
R341	1-247-717-11	CARBON	2.2K	5%	1/4W
R342	1-249-437-11	CARBON	47K	5%	1/4W
R343	1-249-441-11	CARBON	100K	5%	1/4W
R344	1-249-437-11	CARBON	47K	5%	1/4W
R371	1-247-152-00	CARBON	7.5K	5%	1/4W
R372	1-249-462-11	CARBON	22K	5%	1/4W
R398	1-216-349-00	CARBON	1	5%	1/2W
R399	1-249-429-11	CARBON	10K	5%	1/4W
R501	1-216-683-11	METAL CHIP	22K	0.50%	1/10W
R502	1-216-683-11	METAL CHIP	22K	0.50%	1/10W
R503	1-216-295-00	METAL GLAZE	0	5%	1/10W
R504	1-216-065-00	METAL GLAZE	4.7K	5%	1/10W
R505	1-216-051-00	METAL GLAZE	1.2K	5%	1/10W
R506	1-216-295-00	METAL GLAZE	0	5%	1/10W
R507	1-216-295-00	METAL GLAZE	0	5%	1/10W
R508	1-216-295-00	METAL GLAZE	0	5%	1/10W
R509	1-216-295-00	METAL GLAZE	0	5%	1/10W
R510	1-216-073-00	METAL GLAZE	10K	5%	1/10W
R511	1-216-049-00	METAL GLAZE	1K	5%	1/10W
R512	1-216-083-00	METAL GLAZE	27K	5%	1/10W
R513	1-216-025-00	METAL GLAZE	100	5%	1/10W
R514	1-216-070-00	METAL GLAZE	7.5K	5%	1/10W
R515	1-216-077-00	METAL GLAZE	15K	5%	1/10W
R516	1-216-063-00	METAL GLAZE	3.9K	5%	1/10W
R517	1-216-049-00	METAL GLAZE	1K	5%	1/10W

Ref.No.	Part No.	Description				
R518	1-216-065-00	METAL GLAZE	4.7K	5%	1/10W	
R519	1-216-081-00	METAL GLAZE	22K	5%	1/10W	
R520	1-216-081-00	METAL GLAZE	22K.	5%	1/10W	
R521	1-216-073-00	METAL GLAZE	10K	5%	1/10W	
R522	1-216-097-00	METAL GLAZE	100K	5%	1/10W	
R523	1-216-098-00	METAL GLAZE	110K	5%	1/10W	
R524	1-216-099-00	METAL GLAZE	120K	5%	1/10W	
R525	1-216-099-00	METAL GLAZE	120K	5%	1/10W	
R526	1-216-073-00	METAL GLAZE	10K	5%	1/10W	
R527	1-216-077-00	METAL GLAZE	15K	5%	1/10W	
R528	1-216-073-00	METAL GLAZE	10K	5%	1/10W	
R529	1-216-065-00	METAL GLAZE	4.7K	5%	1/10W	
R530	1-216-065-00	METAL GLAZE	4.7K	5%	1/10W	
R532	1-216-073-00	METAL GLAZE	10K	5%	1/10W	
R534	1-216-073-00	METAL GLAZE	10K	5%	1/10W	
R536	1-216-061-00	METAL GLAZE	3.3K	5%	1/10W	
R537	1-216-295-00	METAL GLAZE	0	5%	1/10W	
R540	1-216-073-00	METAL GLAZE	10K	5%	1/10W	
R541	1-216-073-00	METAL GLAZE	10K	5%	1/10W	
R542	1-216-073-00	METAL GLAZE	10K	5%	1/10W	
R543	1-216-083-00	METAL GLAZE	27K	5%	1/10W	
R544	1-216-059-00	METAL GLAZE	2.7K	5%	1/10W	
R545	1-216-009-00	METAL GLAZE	22	5%	1/10W	
R546	1-216-076-00	METAL GLAZE	13K	5%	1/10W	
R547	1-216-065-00	METAL GLAZE	4.7K	5%	1/10W	
R549	1-216-121-00	METAL GLAZE	1M	5%	1/10W	
R550	1-216-097-00	METAL GLAZE	100K	5%	1/10W	
R551	1-216-097-00	METAL GLAZE	100K	5%	1/10W	
R552	1-216-097-00	METAL GLAZE	100K	5%	1/10W	
R553	1-216-073-00	METAL GLAZE	10K	5%	1/10W	
R554	1-216-097-00	METAL GLAZE	100K	5%	1/10W	
R555	1-216-071-00	METAL GLAZE	8.2K	5%	1/10W	
R556	1-216-109-00	METAL GLAZE	330K	5%	1/10W	
R557	1-216-077-00	METAL GLAZE	15K	5%	1/10W	
R558	1-216-114-00	METAL GLAZE	510K	5%	1/10W	
R559	1-216-109-00	METAL GLAZE	330K	5%	1/10W	
R560	1-216-111-00	METAL GLAZE	390K	5%	1/10W	
R561	1-216-085-00	METAL GLAZE	33K	5%	1/10W	
R562	1-216-083-00	METAL GLAZE	27K	5%	1/10W	
R563	1-216-085-00	METAL GLAZE	33K	5%	1/10W	
R565	1-216-681-11	METAL CHIP	18K	0.50%	1/10W	
R566	1-216-678-11	METAL CHIP	13K	0.50%	1/10W	
R567	1-216-081-00	METAL GLAZE	22K	5%	1/10W	
R568	1-216-085-00	METAL GLAZE	33K	5%	1/10W	
R569	1-216-073-00	METAL GLAZE	10K	5%	1/10W	
R570	1-216-085-00	METAL GLAZE	33K	5%	1/10W	
R571	1-216-049-00	METAL GLAZE	1K	5%	1/10W	
R572	1-216-017-00	METAL GLAZE	47	5%	1/10W	
R573	1-216-081-00	METAL GLAZE	22K	5%	1/10W	
R574	1-216-025-00	METAL GLAZE	100	5%	1/10W	
R575	1-216-017-00	METAL GLAZE	47	5%	1/10W	
R576	1-216-025-00	METAL GLAZE	100	5%	1/10W	
R577	1-216-031-00	METAL GLAZE	180	5%	1/10W	
R578	1-216-031-00	METAL GLAZE	180	5%	1/10W	
R579	1-216-025-00	METAL GLAZE	100	5%	1/10W	
R580	1-216-061-00	METAL GLAZE	3.3K	5%	1/10W	
R581	1-216-069-00	METAL GLAZE	6.8K	5%	1/10W	

Ref.No.	Part No.	Description				
R584	1-216-061-00	METAL GLAZE	3.3K	5%	1/10W	
R585	1-216-069-00	METAL GLAZE	6.8K	5%	1/10W	
R586	1-216-085-00	METAL GLAZE	33K	5%	1/10W	
R587	1-216-085-00	METAL GLAZE	33K	5%	1/10W	
R588	1-216-061-00	METAL GLAZE	3.3K	5%	1/10W	
R589	1-216-085-00	METAL GLAZE	33K	5%	1/10W	
R590	1-216-073-00	METAL GLAZE	10K	5%	1/10W	
R591	1-216-085-00	METAL GLAZE	33K	5%	1/10W	
R592	1-216-085-00	METAL GLAZE	33K	5%	1/10W	
R593	1-216-061-00	METAL GLAZE	3.3K	5%	1/10W	
R594	1-216-085-00	METAL GLAZE	33K	5%	1/10W	
R595	1-216-073-00	METAL GLAZE	10K	5%	1/10W	
R596	1-216-073-00	METAL GLAZE	10K	5%	1/10W	
R597	1-216-033-00	METAL GLAZE	220	5%	1/10W	
R598	1-216-045-00	METAL GLAZE	680	5%	1/10W	
R599	1-216-073-00	METAL GLAZE	10K	5%	1/10W	
R600	1-216-049-00	METAL GLAZE	1K	5%	1/10W	
R601	1-216-073-00	METAL GLAZE	10K	5%	1/10W	
R602	1-216-049-00	METAL GLAZE	1K	5%	1/10W	
R603	1-216-073-00	METAL GLAZE	10K	5%	1/10W	
R608	1-216-065-00	METAL GLAZE	4.7K	5%	1/10W	
R609	1-216-121-00	METAL GLAZE	1M	5%	1/10W	
R610	1-216-048-00	METAL GLAZE	910	5%	1/10W	
R611	1-216-089-00	METAL GLAZE	47K	5%	1/10W	
R612	1-216-037-00	METAL GLAZE	330	5%	1/10W	
R617	1-216-085-00	METAL GLAZE	33K	5%	1/10W	
R618	1-216-085-00	METAL GLAZE	33K	5%	1/10W	
R619	1-216-089-00	METAL GLAZE	47K	5%	1/10W	
R620	1-216-073-00	METAL GLAZE	10K	5%	1/10W	
R621	1-216-049-00	METAL GLAZE	1K	5%	1/10W	
R622	1-216-117-00	METAL GLAZE	680K	5%	1/10W	
R623	1-216-117-00	METAL GLAZE	680K	5%	1/10W	
R625	1-216-662-11	METAL CHIP	3K	0.50%	1/10W	
R626	1-216-677-11	METAL CHIP	12K	0.50%	1/10W	
R627	1-216-077-00	METAL GLAZE	15K	5%	1/10W	
R628	1-216-061-00	METAL GLAZE	3.3K	5%	1/10W	
R629	1-216-077-00	METAL GLAZE	15K	5%	1/10W	
R630	1-216-100-00	METAL GLAZE	130K	5%	1/10W	
R631	1-216-081-00	METAL GLAZE	22K	5%	1/10W	
R632	1-216-081-00	METAL GLAZE	22K	5%	1/10W	
R633	1-216-101-00	METAL GLAZE	150K	5%	1/10W	
R634	1-216-101-00	METAL GLAZE	150K	5%	1/10W	
R635	1-216-077-00	METAL GLAZE	15K	5%	1/10W	
R636	1-216-061-00	METAL GLAZE	3.3K	5%	1/10W	
R637	1-216-081-00	METAL GLAZE	22K	5%	1/10W	
R638	1-216-081-00	METAL GLAZE	22K	5%	1/10W	
R639	1-216-089-00	METAL GLAZE	47K	5%	1/10W	
R640	1-216-089-00	METAL GLAZE	47K	5%	1/10W	
R641	1-216-095-00	METAL GLAZE	82K	5%	1/10W	
R642	1-216-081-00	METAL GLAZE	22K	5%	1/10W	
R643	1-216-073-00	METAL GLAZE	10K	5%	1/10W	
R645	1-216-073-00	METAL GLAZE	10K	5%	1/10W	
R646	1-216-295-00	METAL GLAZE	0	5%	1/10W	
R647	1-216-073-00	METAL GLAZE	10K	5%	1/10W	
R648	1-216-073-00	METAL GLAZE	10K	5%	1/10W	
R649	1-216-065-00	METAL GLAZE	4.7K	5%	1/10W	
R650	1-216-073-00	METAL GLAZE	10K	5%	1/10W	

Ref.No.	Part No.	Description				
R655	1-216-049-00	METAL GLAZE	1K	5%	1/10W	
R656	1-216-049-00	METAL GLAZE	1K	5%	1/10W	
R657	1-216-033-00	METAL GLAZE	220	5%	1/10W	
R671	1-216-073-00	METAL GLAZE	10K	5%	1/10W	
R672	1-216-073-00	METAL GLAZE	10K	5%	1/10W	
R673	1-216-073-00	METAL GLAZE	10K	5%	1/10W	
R675	1-216-025-00	METAL GLAZE	100	5%	1/10W	
R701	1-249-418-11	CARBON	1.2K	5%	1/4W	
R702	1-249-433-11	CARBON	22K	5%	1/4W	
R703	1-249-425-11	CARBON	4.7K	5%	1/4W	
R704	1-249-425-11	CARBON	4.7K	5%	1/4W	
R705	1-249-423-11	CARBON	3.3K	5%	1/4W	
R706	1-249-418-11	CARBON	1.2K	5%	1/4W	
R707	1-249-428-11	CARBON	8.2K	5%	1/4W	
R708	1-249-423-11	CARBON	3.3K	5%	1/4W	
R709	1-249-420-11	CARBON	1.8K	5%	1/4W	
R710	1-249-418-11	CARBON	1.2K	5%	1/4W	
R711	1-249-425-11	CARBON	4.7K	5%	1/4W	
R712	1-249-428-11	CARBON	8.2K	5%	1/4W	
R713	1-249-423-11	CARBON	3.3K	5%	1/4W	
R714	1-249-420-11	CARBON	1.8K	5%	1/4W	
R715	1-249-418-11	CARBON	1.2K	5%	1/4W	
R716	1-249-425-11	CARBON	4.7K	5%	1/4W	
R717	1-249-420-11	CARBON	1.8K	5%	1/4W	
R718	1-249-418-11	CARBON	1.2K	5%	1/4W	
R719	1-249-425-11	CARBON	4.7K	5%	1/4W	
R720	1-249-441-11	CARBON	100K	5%	1/4W	
R721	1-249-441-11	CARBON	100K	5%	1/4W	
R722	1-249-441-11	CARBON	100K	5%	1/4W	
R724	1-249-441-11	CARBON	100K	5%	1/4W	
R727	1-249-441-11	CARBON	100K	5%	1/4W	
R728	1-249-425-11	CARBON	4.7K	5%	1/4W	
R729	1-249-418-11	CARBON	1.2K	5%	1/4W	
R730	1-249-420-11	CARBON	1.8K	5%	1/4W	
R731	1-249-423-11	CARBON	3.3K	5%	1/4W	
R732	1-249-428-11	CARBON	8.2K	5%	1/4W	
R733	1-249-425-11	CARBON	4.7K	5%	1/4W	
R734	1-249-418-11	CARBON	1.2K	5%	1/4W	
R735	1-249-420-11	CARBON	1.8K	5%	1/4W	
R736	1-249-423-11	CARBON	3.3K	5%	1/4W	
R737	1-249-428-11	CARBON	8.2K	5%	1/4W	
R738	1-249-425-11	CARBON	4.7K	5%	1/4W	
R739	1-249-418-11	CARBON	1.2K	5%	1/4W	
R740	1-249-420-11	CARBON	1.8K	5%	1/4W	
R741	1-249-423-11	CARBON	3.3K	5%	1/4W	
R742	1-249-428-11	CARBON	8.2K	5%	1/4W	
R743	1-249-433-11	CARBON	22K	5%	1/4W	
R744	1-249-433-11	CARBON	22K	5%	1/4W	
R745	1-249-433-11	CARBON	22K	5%	1/4W	
R746	1-249-433-11	CARBON	22K	5%	1/4W	
R777	1-216-349-00	CARBON	1	5%	1/2W	
R801	1-247-804-11	CARBON	75	5%	1/4W	
R802	1-249-437-11	CARBON	47K	5%	1/4W	
R803	1-249-421-11	CARBON	2.2K	5%	1/4W	
R804	1-249-429-11	CARBON	10K	5%	1/4W	
R805	1-249-428-11	CARBON	8.2K	5%	1/4W	
R806	1-247-804-11	CARBON	75	5%	1/4W	

Ref.No.	Part No.	Description				
R807	1-249-417-11	CARBON	1K	5%	1/4W	
R808	1-249-417-11	CARBON	1K	5%	1/4W	
R809	1-249-429-11	CARBON	10K	5%	1/4W	
R810	1-249-425-11	CARBON	4.7K	5%	1/4W	
R811	1-249-417-11	CARBON	1K	5%	1/4W	
R812	1-249-425-11	CARBON	4.7K	5%	1/4W	
R813	1-249-417-11	CARBON	1K	5%	1/4W	
R814	1-249-425-11	CARBON	4.7K	5%	1/4W	
R815	1-247-840-00	CARBON	2.4K	5%	1/4W	
R816	1-249-421-11	CARBON	2.2K	5%	1/4W	
R817	1-249-435-11	CARBON	33K	5%	1/4W	
R818	1-249-429-11	CARBON	10K	5%	1/4W	
R901	1-249-417-11	CARBON	1K	5%	1/4W	
R902	1-249-425-11	CARBON	4.7K	5%	1/4W	
R903	1-249-425-11	CARBON	4.7K	5%	1/4W	
R904	1-249-421-11	CARBON	2.2K	5%	1/4W	
R905	1-249-421-11	CARBON	2.2K	5%	1/4W	
R906	1-249-417-11	CARBON	1K	5%	1/4W	
R907	1-249-417-11	CARBON	1K	5%	1/4W	
R908	1-249-417-11	CARBON	1K	5%	1/4W	
R909	1-249-417-11	CARBON	1K	5%	1/4W	
R910	1-249-425-11	CARBON	4.7K	5%	1/4W	
R911	1-249-429-11	CARBON	10K	5%	1/4W	
R912	1-249-424-11	CARBON	3.9K	5%	1/4W	
R913	1-249-425-11	CARBON	4.7K	5%	1/4W	
R915	1-249-425-11	CARBON	4.7K	5%	1/4W	
R916	1-249-433-11	CARBON	22K	5%	1/4W	
R917	1-249-433-11	CARBON	22K	5%	1/4W	
R951	1-216-057-00	METAL GLAZE	2.2K	5%	1/10W	
R952	1-216-057-00	METAL GLAZE	2.2K	5%	1/10W	
R953	1-216-057-00	METAL GLAZE	2.2K	5%	1/10W	
R954	1-216-057-00	METAL GLAZE	2.2K	5%	1/10W	
R955	1-216-089-00	METAL GLAZE	47K	5%	1/10W	
R956	1-216-083-00	METAL GLAZE	27K	5%	1/10W	
R957	1-216-063-00	METAL GLAZE	3.9K	5%	1/10W	
R958	1-216-085-00	METAL GLAZE	33K	5%	1/10W	
R959	1-216-081-00	METAL GLAZE	22K	5%	1/10W	
R960	1-216-079-00	METAL GLAZE	18K	5%	1/10W	
R961	1-216-079-00	METAL GLAZE	18K	5%	1/10W	
R962	1-216-081-00	METAL GLAZE	22K	5%	1/10W	
R963	1-216-085-00	METAL GLAZE	33K	5%	1/10W	
R964	1-216-083-00	METAL GLAZE	27K	5%	1/10W	
R965	1-216-063-00	METAL GLAZE	3.9K	5%	1/10W	
R966	1-216-089-00	METAL GLAZE	47K	5%	1/10W	
R967	1-216-089-00	METAL GLAZE	47K	5%	1/10W	
R968	1-216-089-00	METAL GLAZE	47K	5%	1/10W	
R969	1-216-085-00	METAL GLAZE	33K	5%	1/10W	
R970	1-216-085-00	METAL GLAZE	33K	5%	1/10W	
R971	1-216-095-00	METAL GLAZE	82K	5%	1/10W	
R972	1-216-065-00	METAL GLAZE	4.7K	5%	1/10W	
R973	1-216-071-00	METAL GLAZE	8.2K	5%	1/10W	
R974	1-216-071-00	METAL GLAZE	8.2K	5%	1/10W	
RV101	1-224-249-XX	RES, ADJ, METAL GLAZE	1K			
RV102	1-224-249-XX	RES, ADJ, METAL GLAZE	1K			
RV201	1-224-249-XX	RES, ADJ, METAL GLAZE	1K			



Ref.No.	Part No.	Description
RV202	1-224-249-XX	RES, ADJ, METAL GLAZE 1K
RV301	1-238-520-11	RES, VAR, CARBON 20K/20K (REC LEVEL)
RV302	1-238-359-11	RES, VAR, CARBON 20K/20K (HEADPHONES LEVEL)
RV501	1-226-774-00	RES, ADJ, METAL GLAZE 47K
RV502	1-226-703-11	RES, ADJ, METAL GLAZE 10K
RV503	1-226-703-11	RES, ADJ, METAL GLAZE 10K
RV504	1-228-995-00	RES, ADJ, CARBON 22K
RV505	1-228-995-00	RES, ADJ, CARBON 22K
RV506	1-228-995-00	RES, ADJ, CARBON 22K
RV507	1-226-773-11	RES, ADJ, METAL GLAZE 22K
RV508	1-226-703-11	RES, ADJ, METAL GLAZE 10K
RV509	1-226-772-11	RES, ADJ, METAL GLAZE 4.7K
RV951	1-238-237-11	RES, ADJ, CERMET 470
RV952	1-238-237-11	RES, ADJ, CERMET 470
RY301	1-515-726-11	RELAY
S11	1-571-471-11	SWITCH, PUSH (1 KEY) (CASSETTE TABLE SLIDE DET)
S12	1-571-489-11	SWITCH, SLIDE (CASSETTE TABLE UP/DOWN DET)
S701	△ 1-571-305-11	SWITCH, PUSH (1 KEY) (POWER)
S702	1-571-520-11	SWITCH, SLIDE (TIMER)
S703	1-570-974-11	SWITCH, SLIDE (INPUT)
S704	1-570-974-11	SWITCH, SLIDE (SKIP)
S706	1-554-303-21	SWITCH, KEY BOARD (COUNTER MODE)
S707	1-554-303-21	SWITCH, KEY BOARD (COUNTER RESET)
S708	1-554-303-21	SWITCH, KEY BOARD (REC MUTE)
S709	1-554-303-21	SWITCH, KEY BOARD (PAUSE)
S710	1-554-303-21	SWITCH, KEY BOARD (REC)
S711	1-554-303-21	SWITCH, KEY BOARD (FF/CUE)
S712	1-554-303-21	SWITCH, KEY BOARD (REC/CUE)
S713	1-554-303-21	SWITCH, KEY BOARD (AMS/FF)
S714	1-554-303-21	SWITCH, KEY BOARD (AMS/RWD)
S715	1-554-303-21	SWITCH, KEY BOARD (PLAY)
S716	1-554-303-21	SWITCH, KEY BOARD (STOP)
S717	1-554-303-21	SWITCH, KEY BOARD (OPEN/CLOSE)
S718	1-554-303-21	SWITCH, KEY BOARD (MUSIC SCAN/START)
S719	1-554-303-21	SWITCH, KEY BOARD (O/END)
S720	1-554-303-21	SWITCH, KEY BOARD (CLEAR)
S721	1-554-303-21	SWITCH, KEY BOARD (START ID AUTO)
S722	1-554-303-21	SWITCH, KEY BOARD (START ID RE-NUMBER)
S723	1-554-303-21	SWITCH, KEY BOARD (1)
S724	1-554-303-21	SWITCH, KEY BOARD (2)
S725	1-554-303-21	SWITCH, KEY BOARD (3)

Ref.No.	Part No.	Description
S726	1-554-303-21	SWITCH, KEY BOARD (START ID WRITE)
S727	1-554-303-21	SWITCH, KEY BOARD (START ID ERASE)
S728	1-554-303-21	SWITCH, KEY BOARD (4)
S729	1-554-303-21	SWITCH, KEY BOARD (5)
S730	1-554-303-21	SWITCH, KEY BOARD (6)
S731	1-554-303-21	SWITCH, KEY BOARD (SKIP ID WRITE)
S732	1-554-303-21	SWITCH, KEY BOARD (SKIP ID ERASE)
S733	1-554-303-21	SWITCH, KEY BOARD (7)
S734	1-554-303-21	SWITCH, KEY BOARD (8)
S735	1-554-303-21	SWITCH, KEY BOARD (9)
S801	1-554-883-11	SWITCH, SLIDE (INPUT SELECTOR)
S901	1-571-878-11	SWITCH, PUSH (2 KEY)
S903	1-570-771-11	SWITCH (LIMIT)
T801	1-459-587-11	COIL (WITH CORE)
T901	△ 1-449-779-11	TRANSFORMER, POWER
TP153	*1-560-060-00	PIN, CONNECTOR 2P
TP253	*1-560-060-00	PIN, CONNECTOR 2P
VC501	8-719-915-30	DIODE FC53M
X351	1-577-074-11	VIBRATOR, CRYSTAL 122.912MHz
X501	1-567-816-11	VIBRATOR, CRYSTAL 18.816MHz
X502	1-567-815-11	VIBRATOR, CRYSTAL 22.579MHz
X503	1-567-814-11	VIBRATOR, CRYSTAL 24.576MHz
X504	1-577-359-21	VIBRATOR, CERAMIC 4.19MHz
X701	1-577-359-21	VIBRATOR, CERAMIC 4.19MHz

#### ACCESSORY & PACKING MATERIAL

1-465-138-11	REMOTE COMMANDER
1-551-734-11	CORD, CONNECTION (RK-74A)
3-750-189-11	MANUAL, INSTRUCTION
4-925-788-01	COVER, BATTERY
*4-931-443-01	CUSHION
*4-931-444-01	INDIVIDUAL CARTON

**Note:** The components identified by mark △ or dotted line with mark △ are critical for safety. Replace only with part number specified.



# DTC-300ES

## SONY<sup>®</sup> SERVICE MANUAL

*AEP Model*

### SUPPLEMENT-1

File this supplement with the service manual.

**Subject :**

1. Loading Gear Adjustment
2. Disassembly

## 1. Loading Gear Adjustment

1. Mount the loading gear while pushing the slant block (guide S1, guide S2) toward the reel side with your hand.
2. Mount the washer.

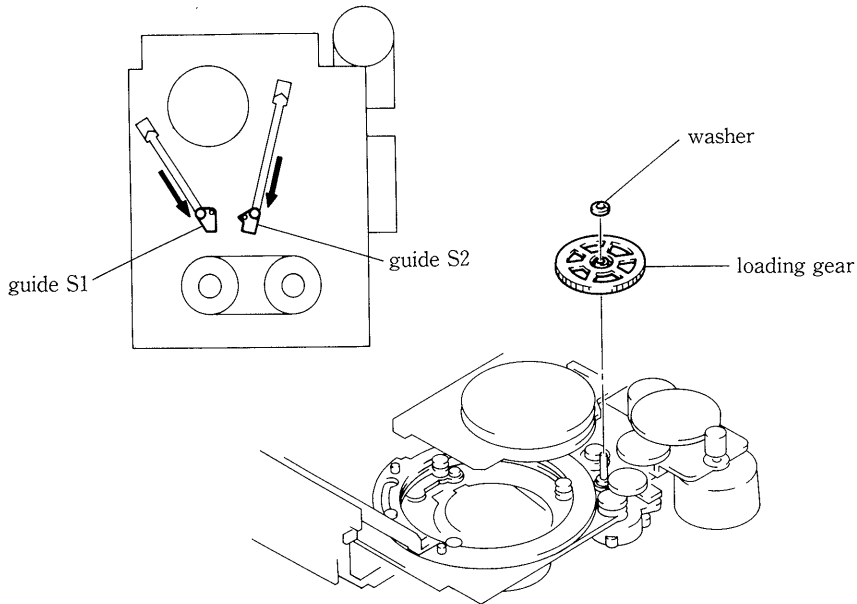

## 2. Disassembly

**NOTE:** Follow the disassembly procedure in the numerical order given.

### Capstan motor removal

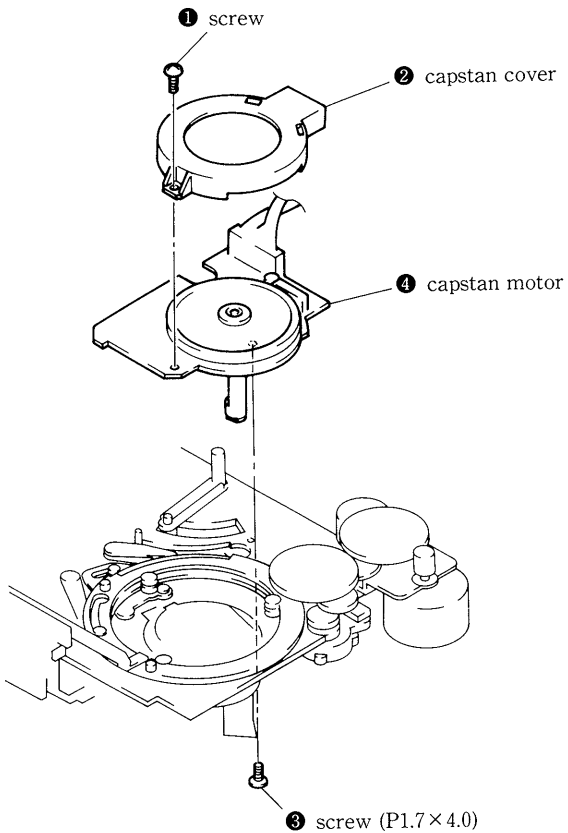

### Loading ring removal

