

# DTC-59ES

## SERVICE MANUAL

US Model  
Canadian Model  
AEP Model  
E Model

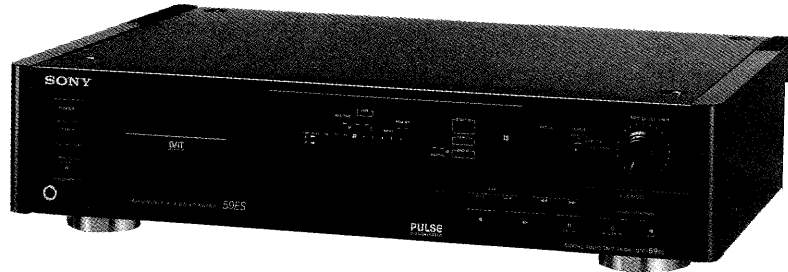

Photo : Black type

### SPECIFICATIONS

Tape	Digital audio tape
Recording head	Rotary head
Recording time	Standard: 120 minutes. Long-play mode: 240 minutes (with DT-120)
Tape speed	Standard: 8.15 mm/s, Long play mode: 4.075 mm/s
Drum rotation	Standard: 2,000 rpm, Long-play mode: 1,000 rpm
Error correction	Double Read Solomon code
<b>Tape</b>	
Track pitch	13.6 $\mu$ m (20.4 $\mu$ m)
Sampling frequency	48 kHz, 44.1 kHz, 32 kHz
Modulation system	8-10 Modulation
Transfer rate	2.46 Mbit/sec.
Number of channel	2 channels, stereo
D/A conversion (Quantization)	Standard: 16-bit linear Long-play mode: 12-bit non-linear
Frequency response	Standard: 2-22,000 Hz ( $\pm 0.5$ dB) Long-play mode: 2-14,500 Hz ( $\pm 0.5$ dB)
Signal to noise ratio	Standard: more than 92 dB Long-play mode: more than 92 dB
Dynamic range	Standard: more than 92 dB Long-play mode: more than 92 dB
Total harmonic distortion	Standard: less than 0.0045% (1 kHz) Long-play mode: less than 0.08% (1 kHz)
Wow and flutter	Below measurable limit ( $\pm 0.001\%$ W. PEAK)

Model Name Using Similar Mechanism	NEW
Tape Transport Mechanism Type	DATM-102

#### Input

	Jack type	Impedance	Rated input level
<b>LINE IN</b>	phono jack	47 kohms	-4 dBs
<b>DIGITAL IN</b>	phono jack	75 ohms	0.5 Vp-p, $\pm 20\%$
<b>DIGITAL IN</b>	optical jack	—	—

#### Output

	Jack type	Impedance	Rated output	Load impedance
<b>LINE OUT</b>	phono jack	470 ohms	-4 dBs	More than 10 kohms
<b>PHONES</b>	stereo phone jack	220 ohms	0.6 mW	32 ohms
<b>DIGITAL OUT</b>	phono jack	75 ohms	0.5 Vp-p $\pm 20\%$	—

DIGITAL OUT (optical jack): wavelength 660 nm

- continued on next page -

DIGITAL AUDIO TAPE DECK  
**SONY**<sup>®</sup>



**General**

Power requirements 120V AC, 60Hz : US, Canadian model  
 220-230V AC, 50/60Hz : AEP model  
 110-120, 220-240V AC, 50/60Hz : E model

Power consumption 32 W

Dimensions Approx. 470 x 110 x 350 mm  
 (w/h/d)  
 (18 5/8 x 4 3/8 x 13 7/8 inches)

Weight Approx. 6.6 kg (14 lb 10 oz)

**Remote commander (supplied)**

Remote control system Infrared control

Power requirements 3V DC, with two size AA (R6)  
 batteries

Dimensions Approx. 63 x 19 x 175 mm  
 (w/h/d)  
 (2 1/2 x 3/4 x 7 inches)

Weight Approx. 130 g (4 oz) incl.  
 batteries.

**Supplied accessories**

Sony batteries SUM-3(NS) (2)

Audio connecting cords (2 phono plugs - 2 phono plugs,  
 stereo for line inputs and outputs) (2)

Screws (4)

Design and specifications are subject to change without  
 notice.

**SAFETY-RELATED COMPONENT WARNING!!**

COMPONENTS IDENTIFIED BY MARK  $\Delta$  OR DOTTED LINE  
 WITH MARK  $\Delta$  ON THE SCHEMATIC DIAGRAMS AND IN  
 THE PARTS LIST ARE CRITICAL TO SAFE OPERATION. REPLACE  
 THESE COMPONENTS WITH SONY PARTS WHOSE PART  
 NUMBERS APPEAR AS SHOWN IN THIS MANUAL OR IN  
 SUPPLEMENTS PUBLISHED BY SONY.

**ATTENTION AU COMPOSANT AYANT RAPPORT  
 À LA SÉCURITÉ**

LES COMPOSANTS IDENTIFIÉS PAR UNE MARQUE  $\Delta$  SUR  
 LES DIAGRAMMES SCHÉMATIQUES ET LA LISTE DES PIÈCES  
 SONT CRITIQUES POUR LA SÉCURITÉ DE FONCTIONNE-  
 MENT. NE REMPLACER SES COMPOSANTS QUE PAR DES  
 PIÈCES SONY DONT LES NUMÉROS SONT DONNÉS DANS  
 CE MANUEL OU DANS LES SUPPLÉMENTS PUBLIÉS PAR  
 SONY.

**TABLE OF CONTENTS**

<u>Section</u>	<u>Title</u>	<u>Page</u>
<b>1. GENERAL</b>		
	Features .....	4
	Location and Function of Controls .....	5
	Clock Setting .....	9
<b>2. DISASSEMBLY</b>		<b>10</b>
<b>3. ADJUSTMENTS</b>		
3-1.	Electrical Adjustments .....	15
3-2.	Checks for Date Function .....	17
<b>4. DIAGRAMS</b>		
4-1.	Circuit Boards Location .....	18
4-2.	Block Diagram .....	19
4-3.	Waveforms .....	22
4-4.	Semiconductor Lead Layouts .....	25
4-5.	Schematic Diagram - MD / Power Supply / Display Section - .....	27
4-6.	Printed Wiring Boards - MD / Power Supply / Display Section - .....	31
4-7.	Printed Wiring Boards - Main Section - .....	35
4-8.	Schematic Diagram - Main Section - .....	39
4-9.	IC Block Diagrams .....	43
4-10.	Pin Functions .....	46
<b>5. EXPLODED VIEWS</b>		
5-1.	Cabinet Section .....	55
5-2.	Front Panel Section .....	56
5-3.	Chassis Section .....	57
5-4.	Mechanism Section 1 .....	58
5-5.	Mechanism Section 2 .....	59
5-6.	Mechanism Section 3 .....	60
5-7.	Mechanism Section 4 .....	61
<b>6. ELECTRICAL PARTS LIST</b>		<b>62</b>

**PRECAUTIONS FOR INSPECTIONS AND REPAIR WITH POWER OFF**

Before beginning repair work after turning OFF the main switch, be sure to first remove CN932 (EH8P) of the power board. When assembling the equipment, be sure to plug this connector last.

This is because, even with the main switch turned OFF, electric charges still remain in the smoothing capacitor in the power board. Therefore, if another flexible board is inserted or removed, a terminal of the power supply may short an adjacent terminal while destroying the device.

## MODEL IDENTIFICATION

### - SPECIFICATION LABEL -

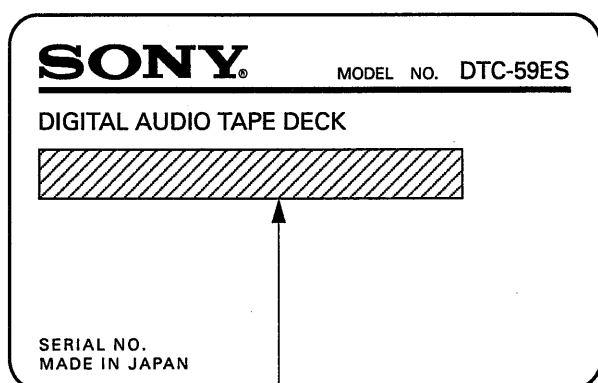

US, Canadian model : AC 120V 60Hz 32W  
 AEP model : AC 220-230V~ 50/60Hz 32W  
 E model : AC:110-120, 220-240V~  
 50/60Hz 32W

### CAUTION

Danger of explosion if battery is incorrectly replaced. Replace only with the same or equivalent type recommended by the equipment manufacturer. Discard used batteries according to manufacturer's instructions.

### ADVERSEL !

Lithiumbatteri – Eksplosionsfare ved fejlagtig håndtering. Udsiftingning må kun ske med batteri af samme fabrikat og type. Lever det brugte batteri tilbage til leverandren.

### ADVARSEL

Lithiumbatteri – Eksplosjonsfare. Ved utskifting benyttes kun batteri som anbefalt av apparatfabrikanten. Brukt batteri returneres apparatleverandren.

### VARNING

Explosionsfara ved felaktigt batteribyte. Använd samma batterityp eller en likvärdig typ som rekommenderas av apparattillverkaren. Kassera använt batteri enligt gällande föreskrifter.

### VAROITUS

Paristo voi räjähtää, jos se on virheellisesti asennettu. Vaihda paristo ainoastaan laitevalmistajan suosittelemaan tyyppiin. Hävitä käytetty paristo valmistajan ohjeiden mukaisesti.

## SAFETY CHECK-OUT

After correcting the original service problem, perform the following safety check before releasing the set to the customer: Check the antenna terminals, metal trim, "metallized" knobs, screws, and all other exposed metal parts for AC leakage. Check leakage as described below.

### LEAKAGE TEST

The AC leakage from any exposed metal part to earth ground and from all exposed metal parts to any exposed metal part having a return to chassis, must not exceed 0.5mA (500 microamperes). Leakage current can be measured by any one of three methods.

1. A commercial leakage tester, such as the Simpson 229 or RCA WT-540A. Follow the manufacturers' instructions to use these instruments.
2. A battery-operated AC milliammeter. The Data Precision 245 digital multimeter is suitable for this job.

3. Measuring the voltage drop across a resistor by means of a VOM or battery-operated AC voltmeter. The "limit" indication is 0.75V, so analog meters must have an accurate low-voltage scale. The Simpson 250 and Sanwa SH-63Trd are examples of a passive VOM that is suitable. Nearly all battery operated digital multimeters that have a 2V AC range are suitable. (See Fig.A)

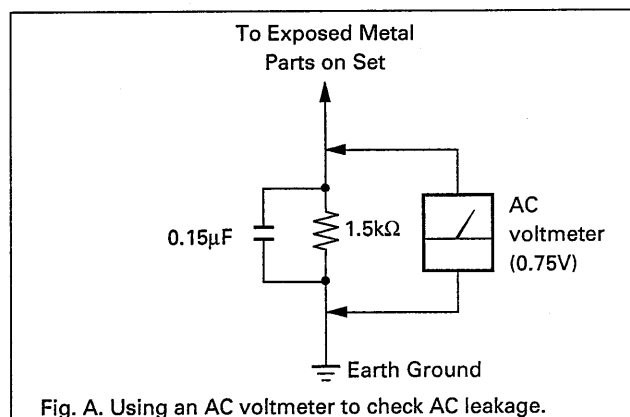

**SECTION 1**  
**GENERAL**

This section is extracted from  
instruction manual.

**Features****Serial copy management system**

This unit utilizes the serial copy management system that permits digital-to-digital recording for one generation. You can record CD sound or other digital formats through a digital-to-digital connection. (See page 42.)

**Date Function automatically memories the recording date and time**

The year, month, day, day of the week, hour, minute and second are automatically memorized in the subcode area during recording, so that during playback you can display this data to check when the tape was recorded. This function is especially convenient when recording live performances, etc.

**Three sampling frequencies**

Recording/playback can be done with three sampling frequencies (48 kHz, 44.1 kHz and 32 kHz).

48 kHz: For analog and digital input signals in a standard mode.

44.1 kHz: For compact disc and pre-recorded DAT tape.

32 kHz: For analog input signals in a long-play mode.

**Long play mode**

This unit can operate in a long-play mode. Analog input signals can be recorded or playback for up to four consecutive hours when the DT-120 DAT cassette tape is used. The sampling frequency will be 32 kHz in the long-play mode.

**Visible cassette loading**

You can view the tape operation through the lid of the cassette compartment. Due to a revolutionary new transport mechanism, cassette loading time has been significantly reduced.

**Excellent sound quality****1-bit A/D converter**

For the A/D converter section which converts analog input signals to digital signals, the unit employs a 1-bit A/D converter which theoretically generates no zero-cross distortion for a clear, elegant sound quality.

**Pulse D/A converter**

Superior playback performance is achieved with a 1-bit D/A converter.

**Rich variety of subcode information**

This unit can record subcode information such as Start IDs, program numbers, Skip IDs, and absolute time data, enabling you to quickly locate tunes and display the playback time in the same manner as when playing compact discs.

**Digital fade-in/fade-out**

Professional sounding fade-in/fade-out of either digital or analog signals can be accomplished by use of the FADER button.

**Post edit recording of sub codes**

You can record or rewrite the following sub codes after the audio signal recording has been completed.

Start ID: Signifies the beginning of a selection.

Program number: Gives a number to the selection.

Skip ID: Signifies the beginning of a portion to be skipped.

End ID: Signifies the end position of recording/playback.

Since sub codes are written on the tape separately from audio signals, the audio signals are not affected.

# Location and Function of Controls

Front Panel/Remote Commander

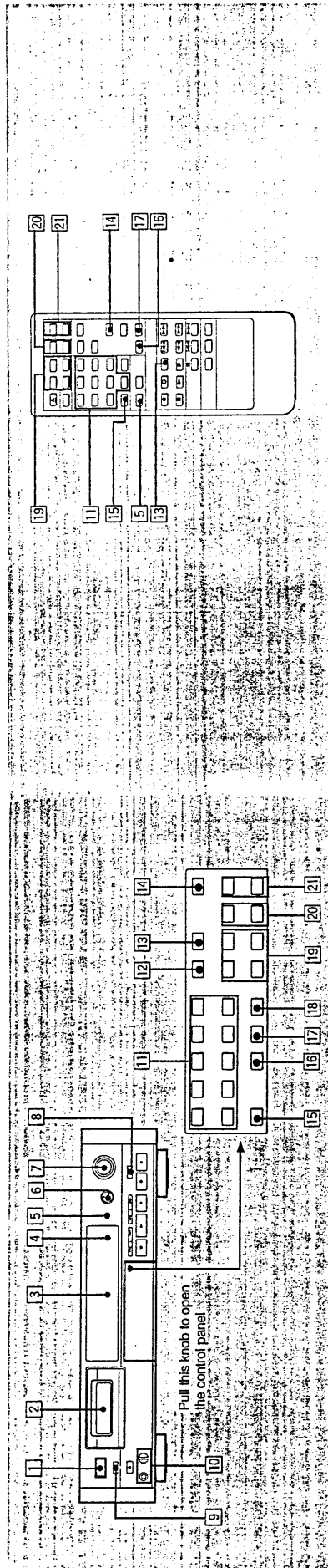

- 1 POWER switch**  
Turns the power on and off.
- 2 Cassette compartment**  
Insert a cassette with the window side up and the safety tab facing you.
- 3 Display window**
- 4 Remote sensor**  
Receives the signal from the remote commander.
- 5 MODE button**  
Selects the display mode among the absolute time, elapsed time of the current selection, remaining time to the end of whole tape and linear counter (tape running time). Each time you press the button, the display changes sequentially.
- 6 INPUT SELECT selector**  
Set according to the signal to be recorded.  
**ANALOG:** For recording from the equipment connected to the LINE IN jacks.  
**OPTICAL:** For recording from the equipment connected to the DIGITAL IN (OPTICAL) jack.  
**COAXIAL:** For recording from the equipment connected to the DIGITAL IN (COAXIAL) jack.
- 7 REC LEVEL (recording level) controls**  
Adjust the recording levels and balance for the analog input signals.  
The outer knob controls the L (left) channel level and the inner knob the R (right) channel level. The knobs can be adjusted together. To adjust each channel independently, turn the knob while holding the other knob.  
When recording digital signals, it is not necessary to adjust the recording levels.
- 8 REC MODE selector**  
Normally set to the STANDARD position.  
When this selector is set to the LONG position, you can record analog input signals or digital signals with 32 kHz in the long-play mode.
- 9 TIMER switch**  
Normally set to the OFF position. When recording or playing back at the desired time using a commercially available audio timer, set to the REC position or the PLAY position respectively.
- 10 PHONES-LEVEL jack and control**  
Insert the headphones plug to this jack and turn the control to adjust the headphones volume level.
- 11 Numeric buttons (0-9)**  
Designate the desired program number to be played back before starting playback. Designate the desired number in the record-pause mode, the program number is written consecutively from the designated number.
- 12 MUSIC SCAN button**  
Press to listen to the beginning of each selection successively.
- 13 FADER button**  
Press to fade in or fade out during recording or playback.
- 14 MARGIN RESET button**  
Press to reset the margin of peak level.
- 15 CLEAR button**  
Press to cancel the program number which has been mistakenly entered.
- 16 RECORDED button**  
Press to display the recording day of the tape being played.
- 17 PRESENT button**  
Press to display the current time. Each time the RECORDED or PRESENT button is pressed, day, month and year display, the day of the week display or hour, minute and second display is switched sequentially.
- 18 CLOCK SET button**  
Press to adjust the time of the clock built in this unit. In this mode, the 0 button and the 9 button function as the + and - buttons respectively.
- 19 START ID buttons**  
**AUTO:** Press to turn on and off the AUTO indicator. When the AUTO indicator is lit, the start ID will automatically be written during recording. When the AUTO indicator is not lit, press the START ID WRITE button at the point where you want to write a start ID.  
**WRITE:** Press to write the start ID at the desired point during recording or playback.  
**ERASE:** Press to erase a start ID. When a start ID and a program number are written on the tape, both codes are simultaneously erased by pressing this button.  
**RENUMBER:** Press to renumber all programs on the tape. When only the start IDs are written, pressing this button will insert the proper program numbers beginning with "1". The tape will rewind and start from the beginning to accomplish this function.
- 20 SKIP ID buttons**  
**WRITE:** Press at the beginning of the portion you may wish to skip later. A skip ID will be written from the point where you pressed this button.  
**ERASE:** Press to erase the nearest skip ID which is before the current position.
- 21 END ID buttons**  
**WRITE:** Press to write the ID signifying the end of playback or recording.  
**ERASE:** Press to erase the end ID.

**Front Panel/Remote Commander**

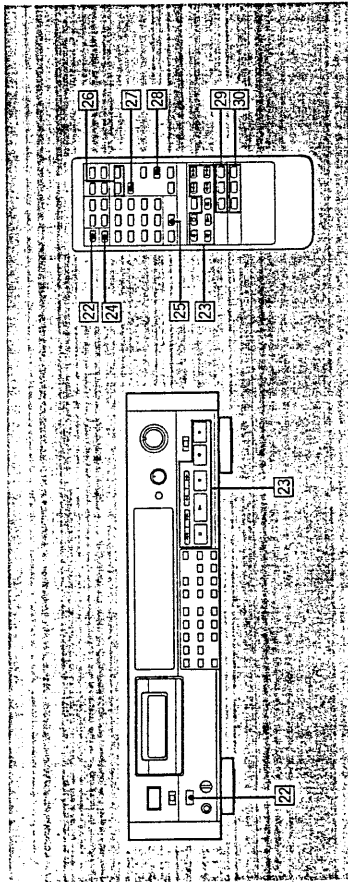

- 22** **▲ OPEN/CLOSE button**  
Press to open or close the cassette compartment.
- 23** **Tape operating buttons**  
  - (stop): Press to stop recording or playback.
  - ▶ (play): Press to play back the tape.
  - ⏏ (PAUSE (pause)): Press to stop for a moment during recording or playback. To restart recording or playback, press this button again or press the ▶ button.
  - ⏪ (rewind): Press to rewind or fast-forward the tape while listening to the sound.
  - ⏩ (fast forward): Press to fast-forward the tape while listening to the sound.
- 24** **DISPLAY MODE button**  
Changes the display mode. (Refer to page 10.)
- 25** **RESET**  
Resets the linear counter to "0M 00S".
- 26** **RMS play buttons**  
  - ENTER:** To program the selections in a desired order, press this button after pressing the numeric buttons.
  - CHECK:** Press to check the programmed contents.
- 27** **REPEAT 1/ALL button**  
Press to play a desired portion repeatedly. Each time you press the button, the indicator changes as follows: REPEAT 1 → REPEAT ALL → off
- 28** **SKIP PLAY button**  
Press to activate the skip ID code function. The portion of the tape previously marked will be skipped.
- 29** **CD operation buttons**  
Operative only for the Sony CD player equipped with a Remote Commander.  
  - ⏏ (pause): Press this button twice to start playback.
  - ⏏ (pause): Press this button once in the playback mode, the deck enters the pause mode.
  - ⏪ (AMS): Press to locate the desired selection on the Compact Disc during playback or in the stop mode.
- 30** **CD SYNCHRO (CD synchronized recording) buttons**  
  - (The playback of the Sony CD player equipped with a Remote Commander and the recording of the DAT deck can be performed simultaneously.)
  - STANDBY:** Press to set the unit in the record-standby mode.
  - START:** Press to start recording of the DAT deck and then playback of the CD player.
  - STOP:** Press to stop the DAT deck recording and the CD player playback.

**Remote Commander Operation**

Each button on the remote commander functions in the same way as those having the same name on the front panel. However, the following operations cannot be performed using the remote commander. Use the front panel controls instead.

- Turning the power on and off
- Selecting digital (optical/coaxial)/analog input source
- Setting the clock
- Adjusting the recording level and balance
- Adjusting the headphones level
- Setting the timer recording/playback
- Selecting the record mode (standard or long)

The following operations can be performed only with the remote commander.

- To activate CD synchronized recording using a Sony CD player and controlling the CD player
- To locate the desired selection on the Compact Disc or to set the CD player in the pause mode (possible only when a Sony CD player is used.)
- Repeat play
- Skip play
- RMS\* play
- RMS: Random Music Sensor
- To reset the linear counter to "0M 00S"

**Installing Batteries**

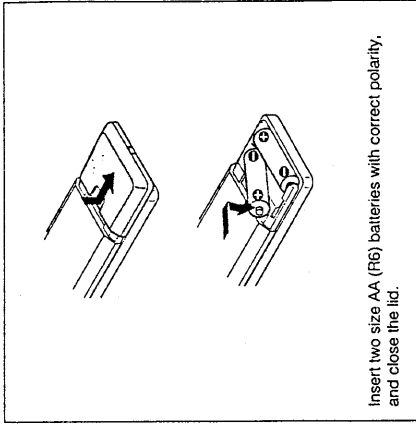

Insert two size AA (R6) batteries with correct polarity, and close the lid.

**Notes on remote control**

- Do not expose the remote sensor on the deck to strong light such as direct sunlight, lighting apparatus, etc.
- Do not place any obstructions between the Remote Commander and the remote sensor, or else operations will not be performed correctly.
- The controllable range is limited. Point the Remote Commander directly at the remote sensor on the deck.
- When remote control operation distance becomes shorter, the batteries are weak. Replace both batteries with new ones.

**To avoid battery leakage**

When the commander will not be used for a long period of time, remove the batteries to avoid damage caused by battery leakage and corrosion.

**Battery life**

About half a year of normal operation can be expected when using the Sony SUM-3 (NS) batteries.

**Display Window**

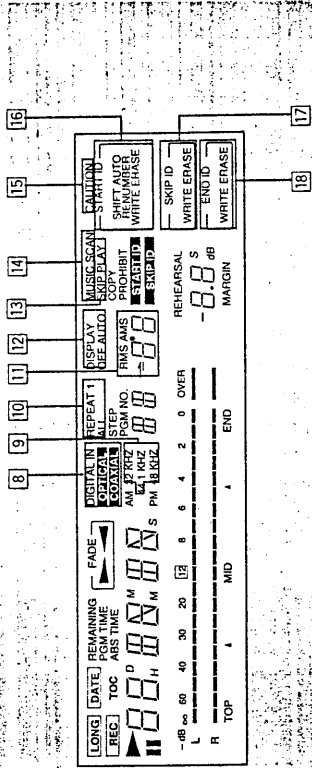

**To turn off the display window**

When the power is turned on, the display window also is turned on. During recording or playback, all display or some parts of the display can be turned off as follows:

**When operating with the front panel controls**  
While pressing the MODE button, press the 0 button. Press the DISPLAY MODE button.

Each time you press the above buttons, the indicators change as follows:

- Normal indicators
- Peak level meters and margin indicators go off. (The DISPLAY OFF indicator lights.)
- All the indicators go off during recording or playback\*. (The DISPLAY OFF AUTO indicator lights momentarily just before the indicators go off.)

\* When pressing the MODE or DISPLAY MODE button except during recording or playback, the DISPLAY OFF AUTO indicator lights. In this case, all the indicators go off immediately after recording or playback starts.

**To change the brightness of the display window**

While pressing the MODE button on the front panel or the COUNTER MODE button on the remote commander, press one of the numeric buttons 1, 2 and 3. The greater number pressed, the darker the display window becomes.

- 1 LONG play mode indicator**  
Lights when recording or playback is being performed in the long play mode.
- 2 TOC (Table Of Contents) indicator**  
When a pre-recorded DAT cassette is played back, this indicator will light.
- 3 DATE indicator**  
Lights when the RECORDED button is pressed to display the recording day of the tape being played. Flashes when the PRESENT button is pressed to display the current time.
- 4 REMAINING (remaining time) indicator**  
Counter shows the remaining time of the tape. PGM TIME (program time): Lights when the counter shows the elapsed time of the current selection. ABS TIME (absolute time) indicator: Lights when the counter shows the elapsed time from the beginning of the tape.
- 5 Time indicator**  
Indicates the tape running time, absolute time, elapsed time of the current selection, remaining time or recording day. Each time the MODE button is pressed, the display is changed.
- 6 Fade in/out indicator**  
Flashes when recording or playback fades in. Flashes when recording of playback fades out.
- 7 AM/PM indicators**  
Show AM or PM of the time.

- 8 INPUT selector indicators**  
The DIGITAL IN OPTICAL or COAXIAL indicator lights according to the position of the INPUT selector. No indicator lights when the INPUT selector is set to the ANALOG position.
- 9 SAMPLING FREQ. (Sampling frequency) indicator**  
48 kHz: For recording/playback of analog input signals (standard mode).  
44.1 kHz: For recording/playback of CD or a pre-recorded DAT cassette.  
32 kHz: For recording/playback of analog input signals (long-play mode).
- 10 REPEAT indicators**  
REPEAT 1: Lights when a desired selection is played back repeatedly.  
REPEAT ALL: Lights when all the selections are played back repeatedly.
- 11 AMS (Automatic Music Sensor)/RMS (Random Music Sensor) indicators**  
Show the number of selections to be skipped ahead or behind in the AMS operation. When designating a selection directly by the numeric button and the target selection while the selection is being searched for. When programming the desired selections in the RMS operation (page 39), the display shows the program number of the selection to be programmed.
- 12 DISPLAY OFF/AUTO indicators**  
The DISPLAY OFF indicator lights when peak level meters and margin indicators are turned off. The DISPLAY-OFF AUTO indicator lights momentarily before all the indicators are turned off.

- 13 SKIP PLAY indicator**  
When this indicator is lit during playback, the portion marked by the skip ID is skipped and playback continues from the next start ID.
- 14 MUSIC SCAN indicator**  
Lights after the MUSIC SCAN button is pressed to listen to the beginning of each selection successively.
- 15 CAUTION indicator**  
Lights when moisture condensation occurs. If this happens, the deck stops functioning automatically. (See page 4.)
- 16 START ID mode indicators**  
AUTO: Lights when the AUTO button is pressed to write the start ID automatically.  
RENUMBER: Lights when the RENUMBER button is pressed to renumber the program numbers.  
WRITE: Lights when writing the start ID manually.  
ERASE: Lights when erasing the start ID.  
AUTO RENUMBER: Lights when renumbering program numbers automatically.  
SHIFT RENUMBER: Lights when shifting the start ID and program number position.
- 17 SKIP ID mode indicator**  
WRITE: Lights when writing the skip ID.  
ERASE: Lights when erasing the skip ID.
- 18 END ID mode indicator**  
WRITE: Lights when writing the end ID.  
ERASE: Lights when erasing the end ID.

Display Window

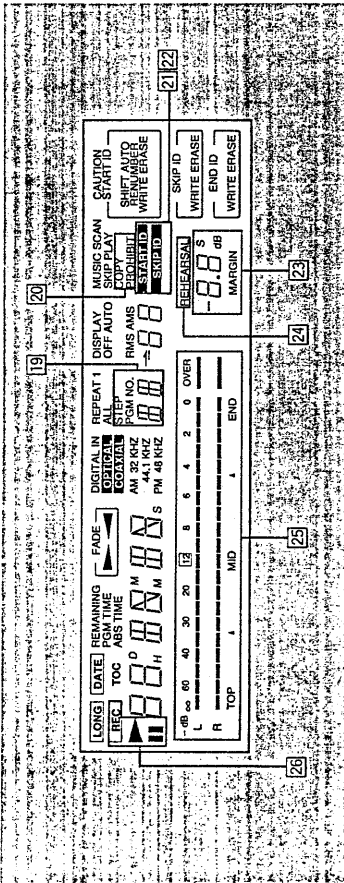

- 19 STEP/PGM NO. Indicator**  
Shows the program number of the selection being played. When programming the desired selection with the RMS operation (page 39), the display shows the step number of the programmed selection.
- 20 COPY PROHIBIT Indicator**  
Lights when recording the digital signal with the copy prohibit code. In this case, record with the LINE IN jacks.
- 21 START ID Indicator**  
Flashes when writing (for 9 or 18 seconds) or erasing a start ID code, and lights when the start ID is detected during playback.
- 22 SKIP ID Indicator**  
Lights when writing (for 1 or 2 seconds) or erasing a skip ID code or when the skip ID is detected during playback.
- 23 MARGIN Indicator**  
Shows how much margin there is between the peak level of input audio signal and 0 dB.
- 24 REHEARSAL Indicator**  
Lights while the rehearsal function is activated (page 29).
- 25 Peak level meters/Frequencies map**  
Indicate the signal levels during playback and recording. There are separate meters for each left and right channel. These meters have a peak hold function which indicates the peak level momentarily. When pressing the 4 button while keeping the MODE button pressed, the sampling frequencies with which the tape was recorded is displayed.
- 26 Tape operation indicators**  
**REC**: Lights during recording or in the record-pause mode.  
**▶**: Lights during recording or playback. It also lights in the record-pause mode or in the play-pause mode.  
**||**: Lights in the record-pause mode or in the play-pause mode.

Rear Panel Jacks

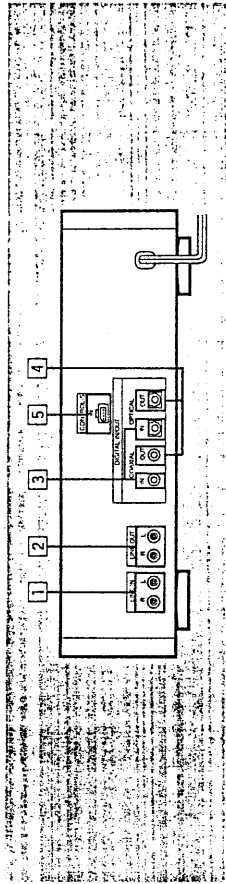

- 1 LINE IN (line input) jacks (phono jack)**  
Connect to the recording outputs of an amplifier. Signals supplied by the amplifier can be recorded using the sampling frequency of 48 kHz in the standard play mode or 32 kHz in the long play mode.
  - 2 LINE OUT (line output) jacks (phono jack)**  
Connect to the DAT or tape inputs of an amplifier. The playback signal of this deck will be output.
  - 3 COAXIAL/OPTICAL DIGITAL IN (digital input) jacks (coaxial phono jack/optical jack)**  
Connect to the digital outputs of an amplifier having a built-in D/A converter or other digital source, such as a CD player for digital-to-digital recording.
  - 4 COAXIAL/OPTICAL DIGITAL OUT (digital output) jack (coaxial phono jack/optical jack)**  
Connect to the digital inputs of an amplifier having a built-in D/A converter or another DAT deck, for playback of a DAT cassette or digital-to-digital recording.
  - 5 CONTROL-S IN jack**  
Connect to the CONTROL-S output of a Sony amplifier or receiver for remote control.
- Notes on connection**
- Use the connecting cords specified in the illustrations.
  - Turn off the power for all equipments before making connections.
  - Be sure to insert the plugs firmly into the jacks. Loose connections may cause hum and noise. When unplugging, grasp the plug and not the cord.
- Notes on the optical cable**
- Do not bend the cord. When the cord is not used, curl it with a diameter of more than 15 cm (5 7/8 inches).
  - Do not use it under high temperatures.
  - When the optical cable is not connected, cover the OPTICAL IN/OUT jacks with the supplied caps.
- Note on sound signals**
- When connecting an optical cable to the DIGITAL IN/DIGITAL OUT jacks, sound signals (L/R) are transmitted together through the cable.
- Note on the CONTROL-S IN jack**
- To remote control this unit through a receiver or amplifier, connect the input of this unit to the CONTROL-S output of a Sony receiver or amplifier, with a CONTROL-S cable. When this connection is used, only remote control commands sent through the receiver or amplifier will be executed. The remote sensor of this unit will not function.



# Clock Setting

This unit employs a built-in clock to keep track of the current date and time. Once you set the date and time, this information will be recorded on the tape along with the audio signal during recording. This function is very convenient because it allows you to check when the tape was recorded when playing the tape later.



## Setting the date and time

Example: Setting the clock to 10:30:00 AM, July 4, 1993 (Sunday)

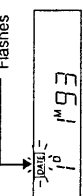
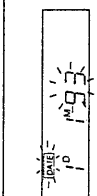
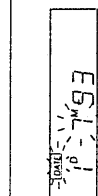
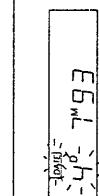
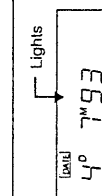

### Setting the day

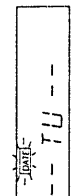
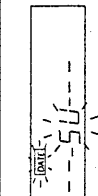
- 1 Display the current date. 
- 2 Set the year. 
- 3 Set the month. 
- 4 Set the day. 
- 5 Complete the setting procedure. 

### Setting the day of the week

- 1 Display the day of the week. 
- 2 Set the day of the week. 
- 3 Complete the setting procedure. 

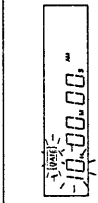
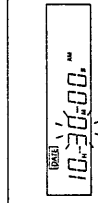
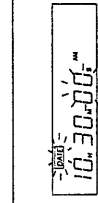
### Setting the time

- 1 Display the current time. 
- 2 Set the hour. 
- 3 Set the minutes. 
- 4 Set the seconds to 0. 
- 5 Start the clock simultaneously with the signal from a timecast (telephone, etc.). 

### To confirm the date or time

Press the PRESENT button to display the date, the day of the week or time. When pressing the PRESENT button once, the date is displayed, when pressing twice, the day of the week is displayed and when pressing three times, the time is displayed. To return to the original counter display, press the MODE button.

### Time display

The time is displayed in 12-hour format.  
Midnight: 12:00 AM  
Noon: 12:00 PM

### Built-in clock

This unit's built-in clock operates using a quartz oscillator, and time variations caused by changes in temperature, etc., may accumulate. For precise recording of hour, minute, and second data by the built-in date function, it is recommended that you set the clock once a week.

### Precautions when setting the clock

- Set the clock while the tape is stopped.
- Although this unit's clock automatically adjusts for leap years and long and short months, do not enter a date which does not exist.

### The day of the week is displayed as follows:

Sunday	SU
Monday	MO
Tuesday	TU
Wednesday	WE
Thursday	TH
Friday	FR
Saturday	SA

### Note

This unit uses a back-up battery to keep the clock running when the power is turned off. The life of the battery under normal use is approximately seven years. When the battery starts to run down, the clock will stop operating normally. When this occurs, have the battery replaced at your dealer or nearest Sony Service Center (a battery replacement fee is required).

## SECTION 2 DISASSEMBLY

- Remove the following devices shown by ❶, etc. In the order of the numbers.

**[CASE]**

Unscrew the four case attachment screws and remove the case.

**[CASSETTE WINDOW]**

- Press the OPEN/CLOSE switch to effect LOADING OUT STATE (if power is not supplied) rotate the pulley in the left side of the Mechanism Deck counterclockwise.)
- Remove the cassette by lifting the window up.

**MECHANISM SECTION**

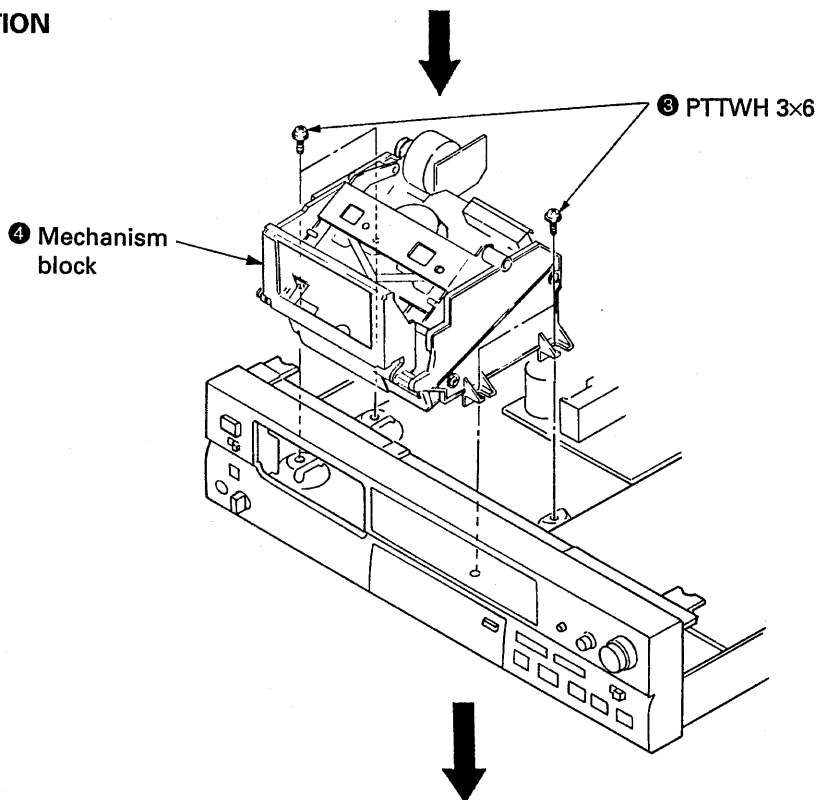

**HOLDER**

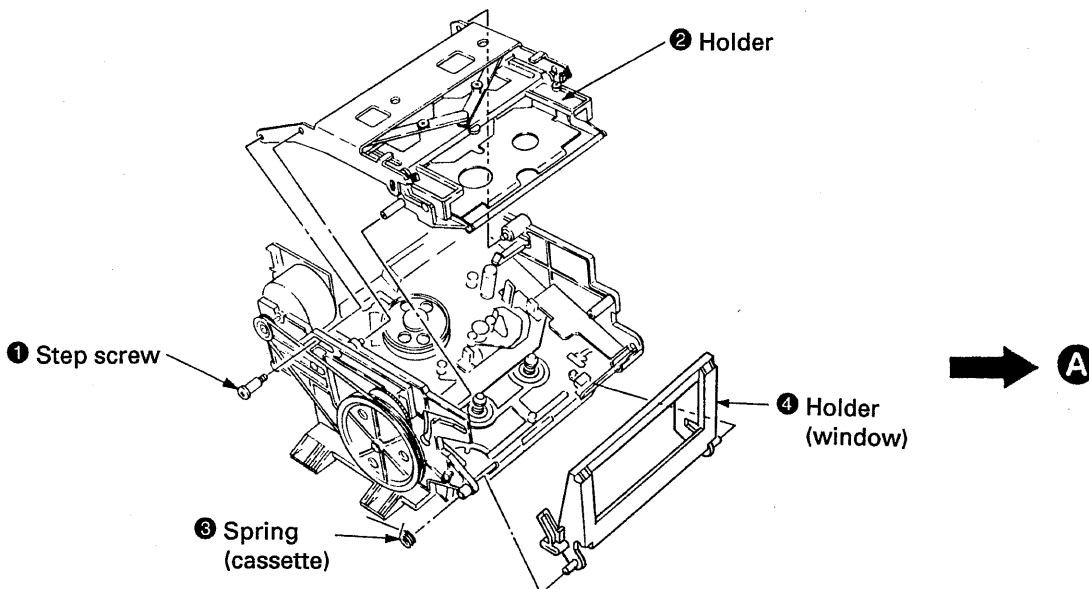

**CASSETTE COMPARTMENT MOTOR (M901), PULLEY, GEAR (CAM) AND SLIDER**

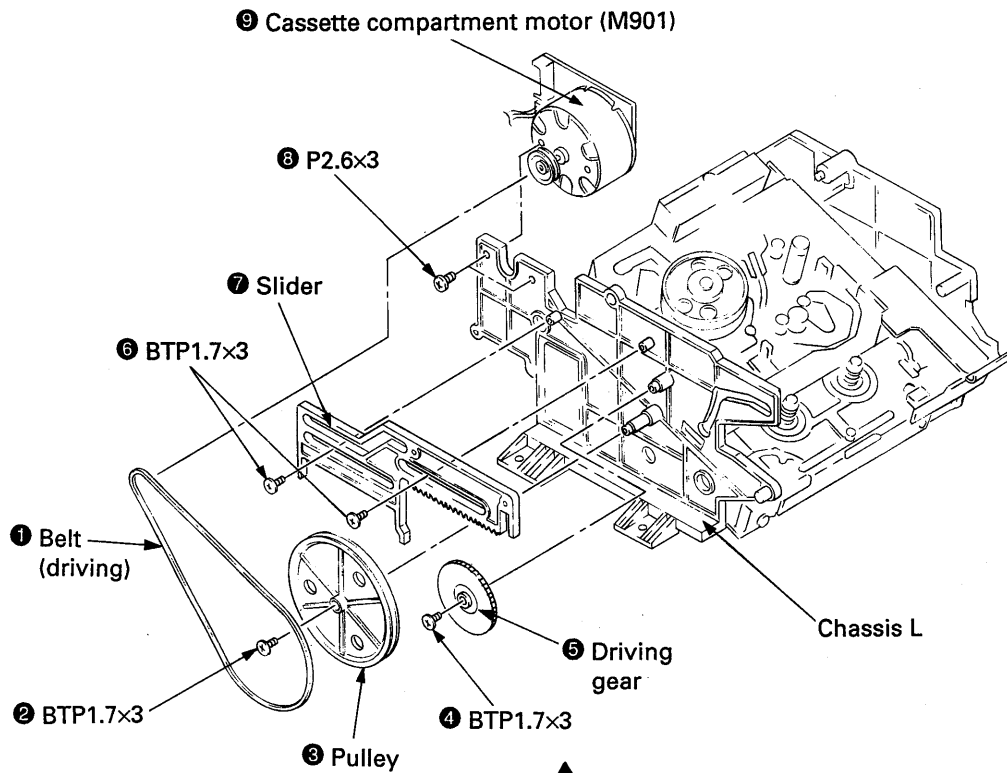

**DRUM**

- 1 Remove the drum lead wires from connectors.

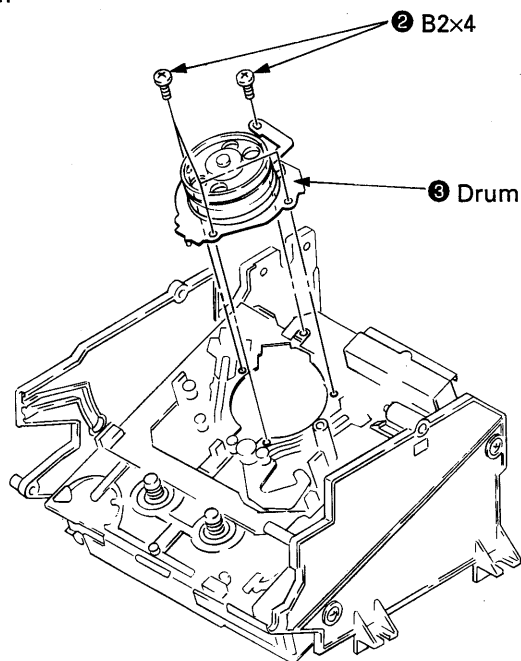

**DRUM DRIVE BOARD, DRIVING CHASSIS**

① Remove the lead wires from connectors on the drum drive board.

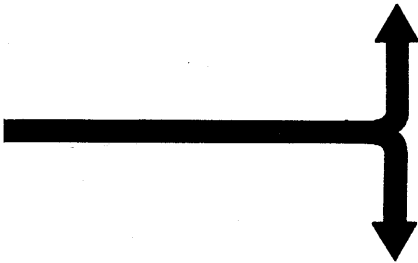
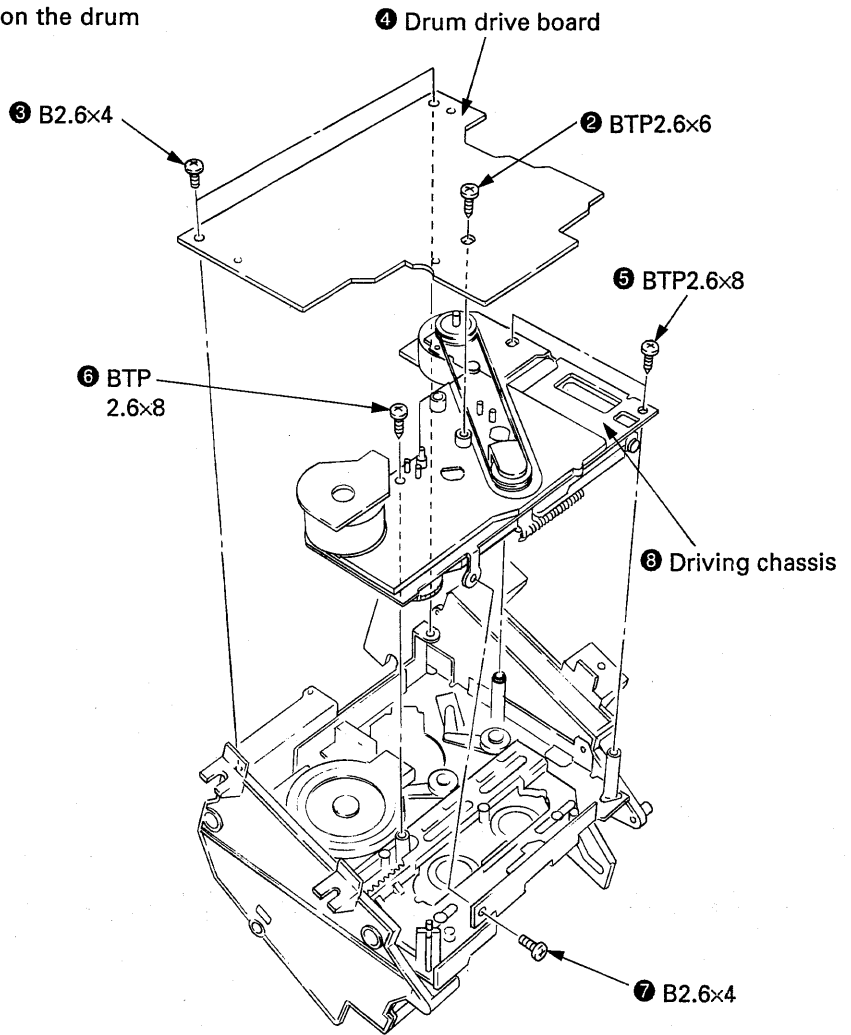

**CAPSTAN MOTOR (M902)**

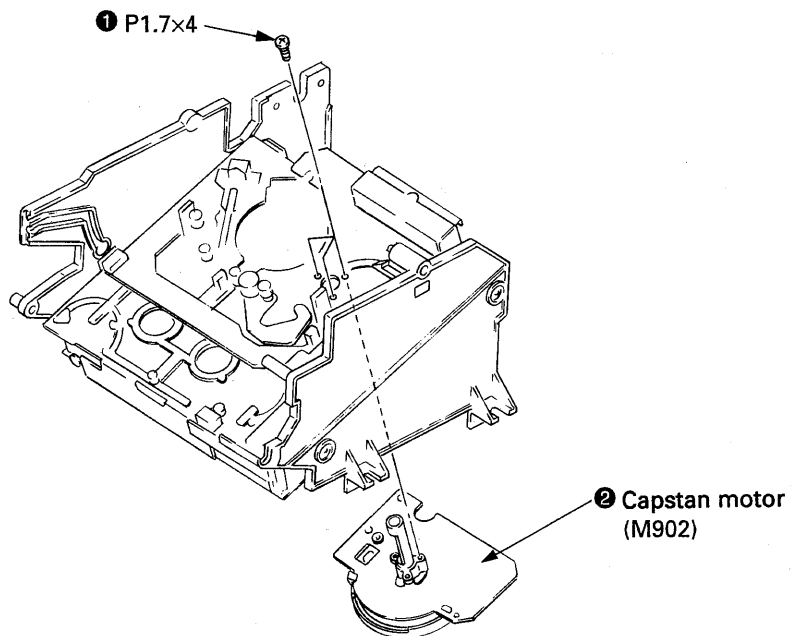

## SECTION 3 ADJUSTMENTS

### Notes When Making Adjustments

1. Adjustments should be performed in the order listed.

2. Use the following test tapes :

TY-7111 (8-909-812-00)	.....Level
TY-7252 (8-909-822-00)	.....Tracking
TY-7551 (8-909-814-00)	.....Functions
TY-30B (8-892-358-00)	.....Blank

Use the following torque meter:

TW-7131 (8-909-708-71)	.....FWD
------------------------	----------

3. Switches and controls should be set as follows unless otherwise specified.

TIMER switch	: OFF
REC MODE switch	: LONG
INPUT switch	: COAXIAL
REC LEVEL control	: Min.
LEVEL (PHONES) control	: Min.

4. Creating an end sensor cassette

(1) Press the tape slider lock and move the slider in the direction indicated by the arrow.

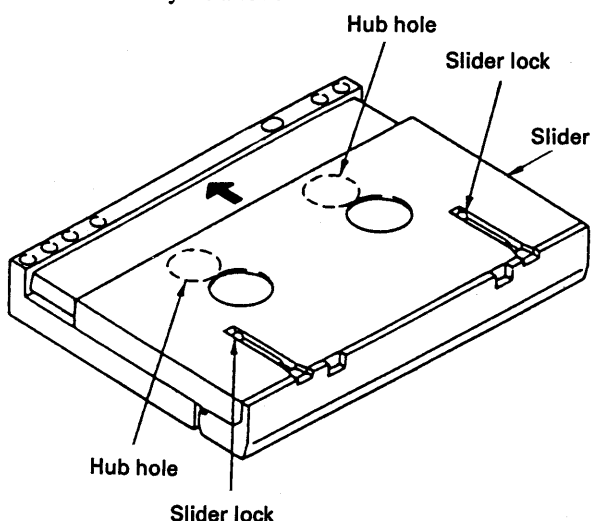

(2) Open the lid and cut the tape.

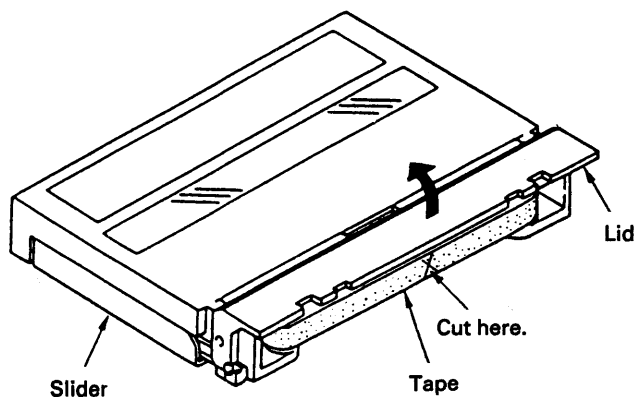

(3) Turn the hubs until the tape is completely inside the cassette (both T and S sides).  
The end sensor cassette for end sensor adjustment is now ready for use.

5. Cleaning of the Revolving Drum

- (1) Fold a chamois (2-034-697-00) or a knit cloth into 4 or more files, slightly impregnate it with a cleaning liquid (9-919-573-00), and softly touch the drum with it and manually rotate the drum slowly counterclockwise by 2 to 3 turns for cleaning.
- (2) At that time, be careful not to move the chamois vertically to the head tip. Otherwise, the head tip may probably be damaged.

6. Be careful not to move RV1 and RV2 on the RF AMP board in the mechanism assembly.

7. To adjust the tape path and guides, remove the holder assembly as shown in the diagram and use the DAT holder jig (J-8000-002-A). This will make it easier to perform adjustments.

- First turning the pulley counterclockwise to put it in loading out status will make removal and reattachment of the holder assembly easier.
- To perform adjustments, turn the pulley clockwise to put it in loading in status, load the cassette tape and set the IN switch to the ON position.

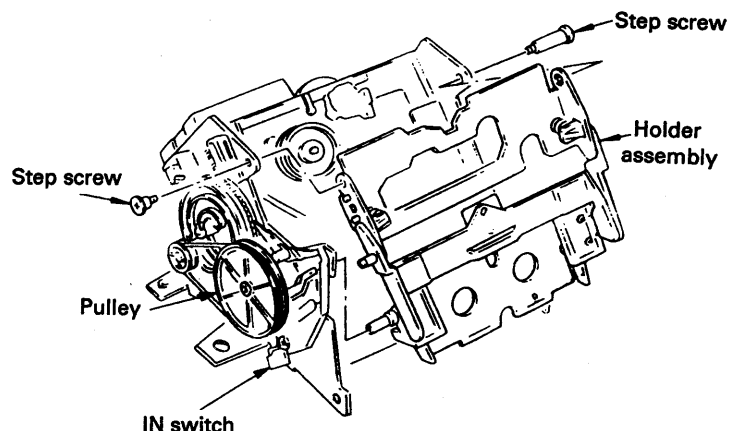

8. Test mode

The test mode is effected by shorting TP (XTEST MAIN, XTEST SERVO and XTEST DISP) on the main board and the control switch board and GND.

(1) Test mode (main · servo)

Turn OFF the power switch, connect XTEST MAIN and XTEST SERVO on the main board to GND and perform the following adjustments.

- Tape path fine adjustment
- DPG adjustment
- ATF pilot (GCA) checking
- End sensor checking
- FWD torque adjustment
- FWD back tension checking and adjustment

(2) Test mode (display)

You can check the following FL display tube and the panel switch by turning OFF the power switch, disconnecting CN932 on the power board, removing flexible board CN752 on the control switch board, connecting XTEST DISP to GND, connecting CN932 again and then turning ON the power switch.

Each grid of the FL display tube sequentially lights up while all tubes being lighted up finally.



Level meters go out one after one.



Press any of the remote controller for DAT in this state. Thus, all level meters go out. (It may sometimes occur that one or two meters remain lighting up according to switch setting at that time.)



Everytime a switch on the panel is pressed, display tubes light up sequentially one after one. With all keys once pressed, all level meters go out.

- To reset the test mode, disconnect the wire shorting XTEST and GND. After completion of adjusting, be sure to reset the test mode.

9. Check the following items for correct tape speed, after completion of adjusting.

- (1) Set the REC MODE switch to STANDARD and check for normal recording and playback. (× 1)
- (2) Set the REC MODE switch to LONG and check for normal recording and playback. (× 0.5)
- (3) With QUE (▶ + ▶▶) or REVIEW (▶ + ◀◀), check that qurrr, qurrr sound is heard. (× 3, × 8)
- (4) Check that correct time is displayed after FF (▶▶▶) or REV (◀◀). (× 16)
- (5) Check that SEARCH (◀▶, ▶◀) is normal.

**Adjust Parts Location**

— Mechanism assembly —

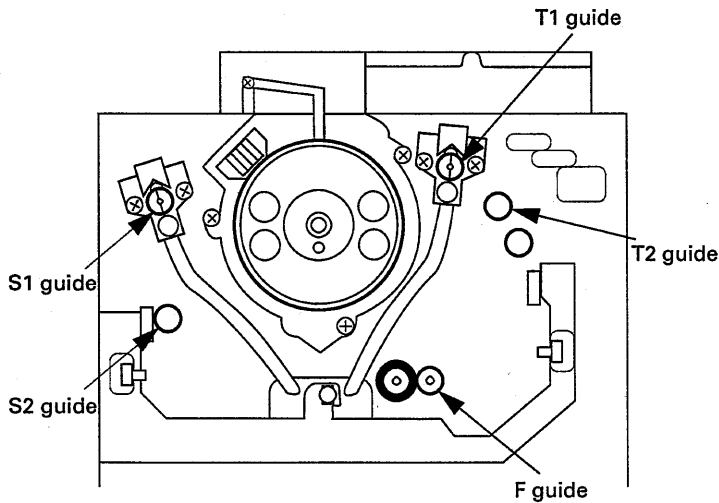

— Main board —  
(Component side)

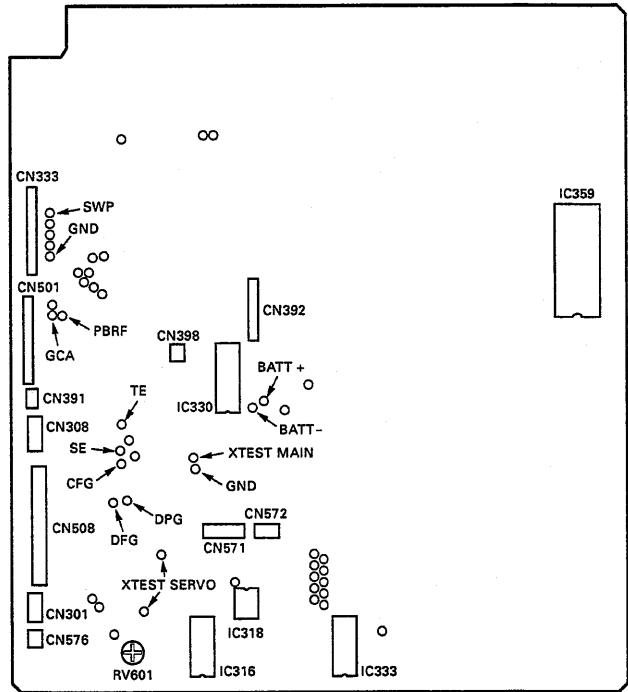

— Control SW board —  
(Conductor side)

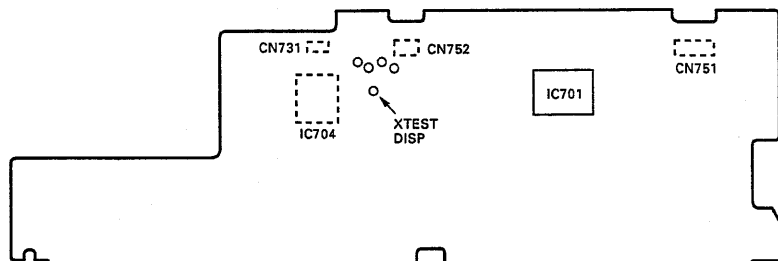

### 3-1. ELECTRICAL ADJUSTMENTS

#### End Sensor Check

Perform the following adjustment when the holder has been removed or part of the mechanism deck section replaced.

#### Check Procedure:

1. Connect an oscilloscope to the test land SE (in the S side) and TE (in the T side) of the main board.
2. Actuate the test mode (main · servo), mount an end sensor cassette and effect the STOP (■) mode.
3. Check that p-p values of waveform of the oscilloscope satisfy the following.

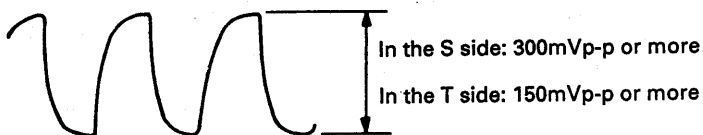

#### FWD Torque Adjustment

#### Adjustment Procedure:

1. Put the set into the test mode (main · servo) and load the FWD torque meter TW-7131 (8-909-708-71).
2. Put the set into the PLAY (▶) mode.
3. Adjust RV601 so that the FWD torque value (take-up side rewinding torque) is between 10 – 13 g·cm (0.14 – 0.18 oz·inch).
4. Confirm that the value indicated by the torque meter is maintained for one full cycle.

Adjustment Point: MAIN board

#### FWD Back Tension Check and Adjustment

#### Check procedure:

1. Put the set into the test mode (main · servo) and load the FWD torque meter TW-7131 (8-909-708-71)
2. Put the set into the PLAY (▶) mode.
3. Confirm that the back tension (supply side) is between 5 – 6 g·cm (0.07 – 0.09 oz·inch).

If this is not satisfied, adjust back tension by rotating the FWD back tension adjustment screw equipped on the side surface of the mechanical deck. After completion of adjusting, be sure to apply screw lock.

4. Confirm that value indicated by the torque meter is maintained for one full cycle.

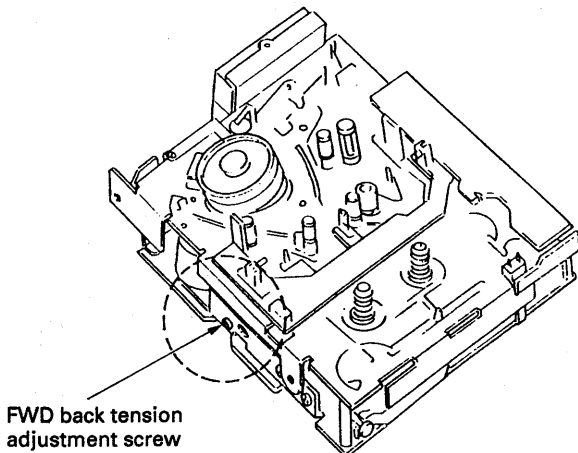

To tighten (clockwise) — back tension becomes larger.  
To loosen (counterclockwise) — back tension becomes smaller.

#### Tape Path Fine Adjustments (× 1.5 FWD Mode)

Perform the following adjustment when the drum has been replaced.

#### Adjustment Procedure :

1. Connect an oscilloscope CH-1 to TP (PBRF) and CH-2 to TP (SWP) on the main board.
2. Put the set into the test mode (main · servo) and load test tape TY-7252 (8-909-822-00).
3. Press the AMS (▶) key.  
Each part of switches on Test Mode.

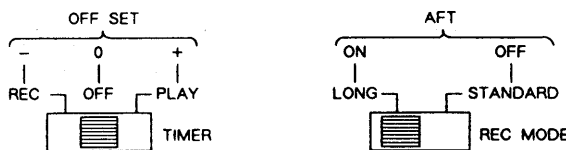

4. With the REC MODE switch set to STANDARD (ATF: OFF) and the TIMER switch set to PLAY or REC (OFFSET: + or -), fine adjust the S1 and T1 guides so that the oscilloscope RF signal waveform remains the same when high-low is repeated.

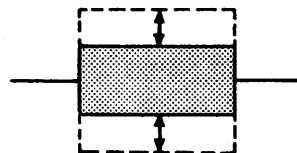

\* Finish the adjustment by screwing in.

5. Check the RF signal waveform with the REC MODE switch set to LONG (ATF: ON) and the TIMER switch set to PLAY or REC (OFFSET: + or -).

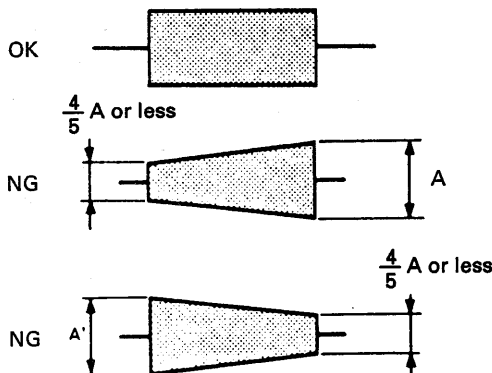

6. Check the RF signal waveform with the REC MODE switch set to LONG (ATF: ON) and the TIMER switch set to PLAY or REC (OFFSET: 0).  
(1) Confirm that the RF signal waveform peak value (B) is 60 mV or more.

- Confirm that the undershoot level of the RF signal waveform's flat portion is within 10%.

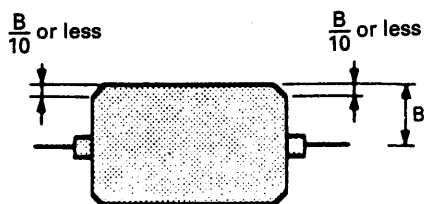

- When the measured values are not within the above tolerance repeat items 3 – 6 above.

**Adjustment Point:** mechanism assembly

### DPG Adjustment

Perform the following adjustment without fail when the drum has been replaced.

#### Adjustment Procedure:

- Connect oscilloscope CH-1 to TP (PBRF) and CH-2 to TP (SWP) on the main board. (Use CH-2 as the trigger. When the CH-2 signal is inverted, the trailing edge can be used for synchronization.)
- Put the set into the test mode (main · servo) and load test tape TY-7252 (8-909-822-00).
- Set the REC MODE switch to LONG (ATF: ON) and the TIMER switch to OFF (OFFSET: 0).
- Press the AMS (▶◀) key.
- Press the ◀◀ and ▶▶ keys as appropriate so that the gap between the oscilloscope SWP and RF signals becomes  $650 \pm 15 \mu\text{sec}$ . (Hold the ◀◀ and ▶▶ keys down for more than 1 second to perform rough adjustment. Hold them down for approximately 0.2 seconds for fine adjustment.)

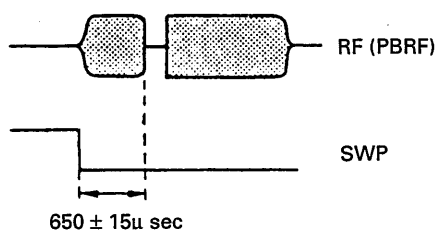

### ATF Pilot (GCA) Check

Perform this adjustment after cleaning the heads with a cleaning cassette.

#### Check Procedure:

- Connect oscilloscope CH-1 to TP (GCA: Gain Control Amp.) and CH-2 to TP (SWP) on the main board. (When the CH-2 signal is inverted, the trailing edge can be used for synchronization.)
- Put the set into the test mode (main · servo) and load test tape TY-7111 (8-909-812-00).

- Actuate the PLAY (▶) mode and check that the GCA waveform on the oscilloscope is as follows.

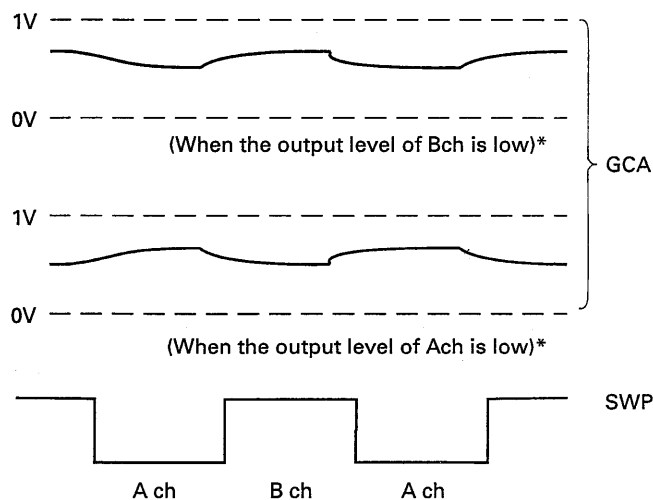

\* Slightly changes depending on the state of the head. NG if the GCA waveform is 1V or more or equal to the GND level.



## 3-2. CHECKS FOR DATE FUNCTION

### Clock IC Back-up Check

- When there is the short-circuit position on the pattern around the lithium battery (BAT301) or the clock IC (IC330) or disconnecting CN398 on removing the front panel assembly the clock is reset. (In spite of pressing PRESENT button, the data indication becomes “--Y--M--D” “--H--M--S”)

At this time, check the back-up function by the procedures given below.

- (1) Connect DC voltmeter to TP (BATT+) and TP (BATT-) on the main board.
- (2) When the power is off, the voltage value of the item (1) should be less than +30 mV.  
(When the voltage value becomes +30 mV or more, Check around IC330 or replace IC330.)
- (3) When the power is on, the voltage value of the item (1) should be less than 0 mV (- (minus) indication).  
(When the voltage value becomes + (plus) indication, Check around D321 or replace D321.)
- (4) When the above voltage values are normal, set the preset date and time (year, month, day, day of the week, hour, minute, second) according to the instruction manual.
- (5) After setting the time on the item (4), turn power off and turn power on several seconds later, and check the clock works normally.

### Back-up Battery Replacement

The life of the back-up battery under normal use (normal temperature, normal humidity) is approximately ten years or more. (On the instruction manual, described “approximately seven years”.)

Be careful about the following points on the battery replacement.

- Repair the cause of the battery wastage by performing mentioned above “Clock IC Back-up Check”.
- The open-circuit voltage of the replaced battery is 3.0 V or more as the new one, and when it is 2.0 V or less, it is completely consumed, replace it with new one.
- After the battery replacement, perform “Clock IC Back-up Check” again and set the time.

### Clock Frequency Adjustment

#### Adjustment Procedure:

1. Connect a frequency counter to pin ⑮ of IC330 and GND on the main board.
2. Turn power on and confirm that the reading on the frequency counter is  $2048.00 \pm 0.02$  Hz. (in normal temperature)
3. Perform “Clock IC Back-up Check” described above.

\* Time setting procedure described on page 9.

# SECTION 4 DIAGRAMS

## 4-1. CIRCUIT BOARDS LOCATION

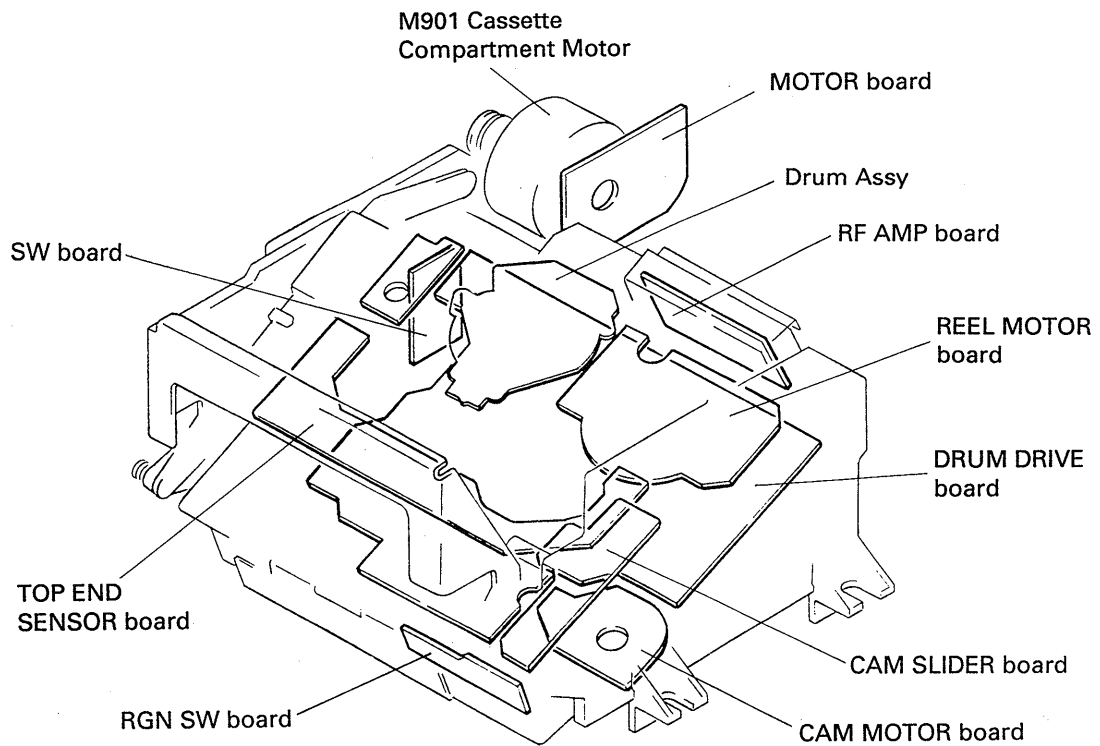
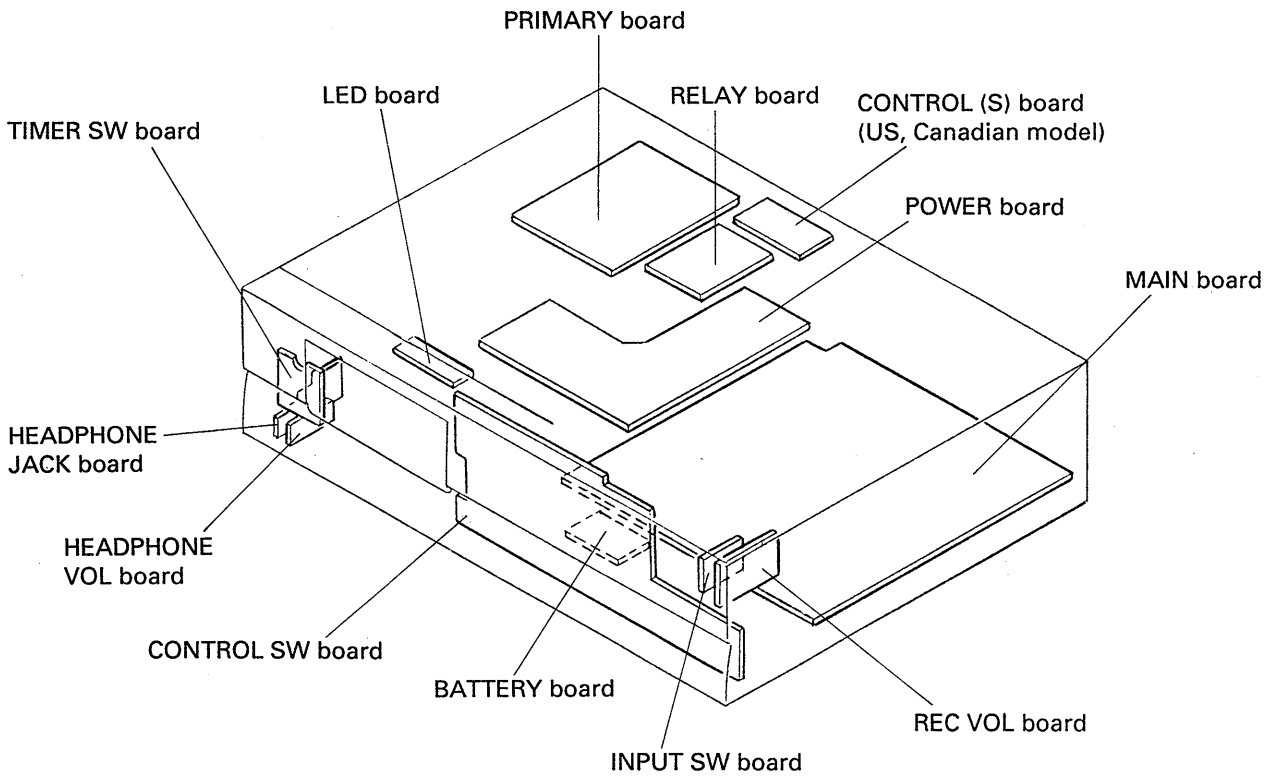

4-2. BLOCK DIAGRAM

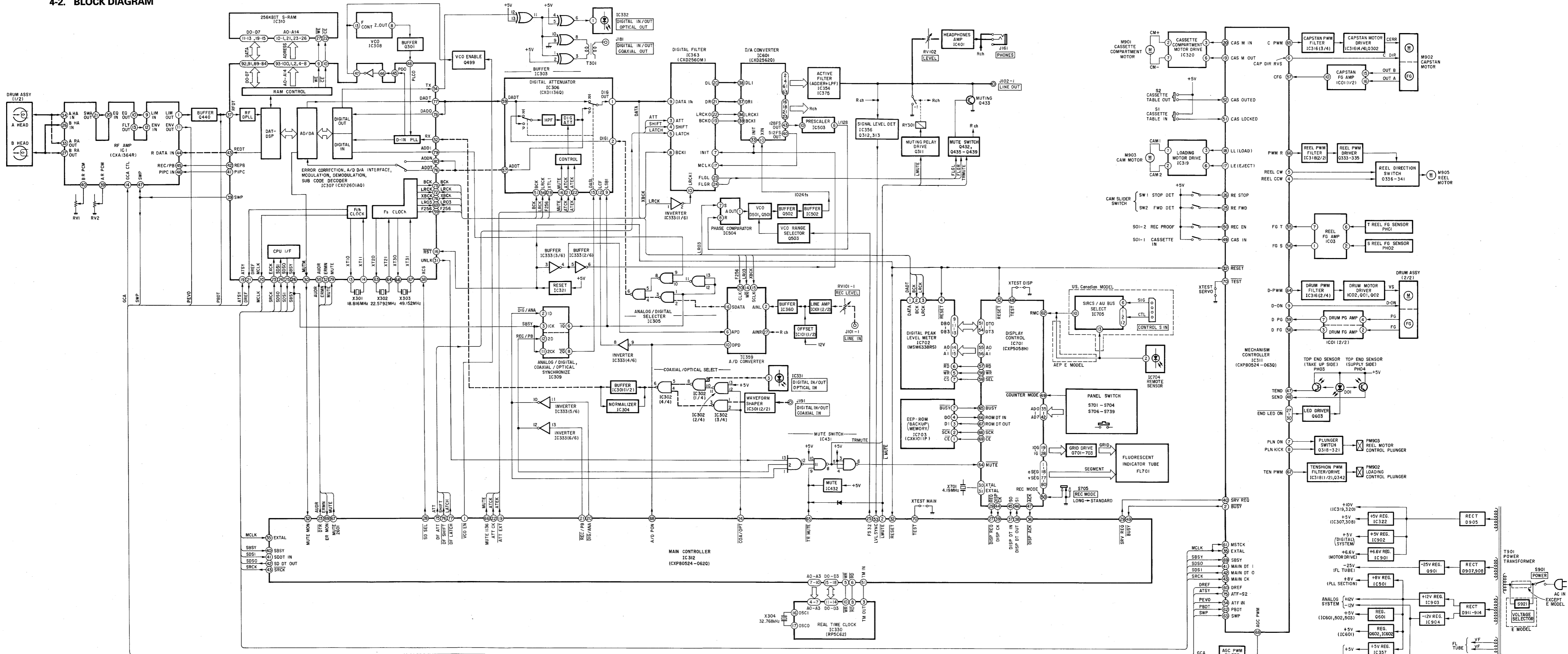

### 4-3. WAVEFORMS

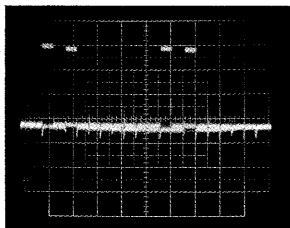

① FL701 ①-② pin  
(1G-20G)  
32Vp-p, 2.5ms

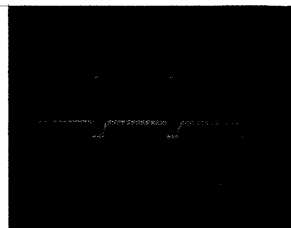

⑥ IC701 ④ pin (SI),  
IC312 ③ pin  
(DISP DT O)  
5.2Vp-p, 0.64ms

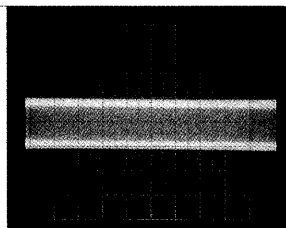

⑪ IC1 ① pin,  
Q440 Base (PBDT)  
PLAY mode 1Vp-p

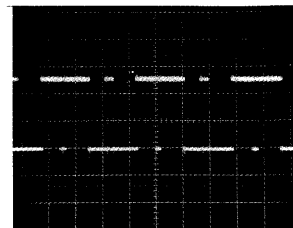

⑯ IC307 ⑦ pin,  
IC306 ⑤ pin (DADO)  
PLAY mode  
5.2Vp-p, 5μs

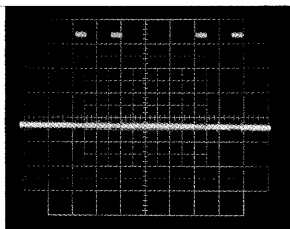

② IC701 ⑱-⑳ pin  
(10G-1G)  
34Vp-p, 2.45ms

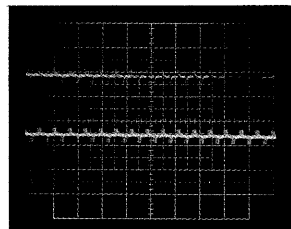

⑦ IC702 ① pin (DATA)  
6.4Vp-p, 0.3μs

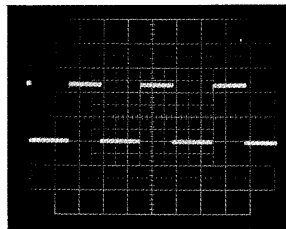

⑫ IC01 ⑩ pin,  
IC311 ⑦ pin (CFG)  
PLAY mode  
5Vp-p, 1.5ms

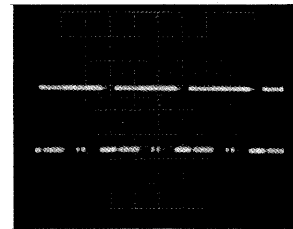

⑰ IC307 ⑦ pin,  
IC306 ⑦ pin (ADDT)  
REC mode  
5.2Vp-p, 5μs

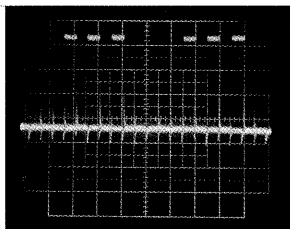

③ IC701 ⑦-⑧ pin,  
①-⑩ pin (a-v)  
38Vp-p, 1.2ms

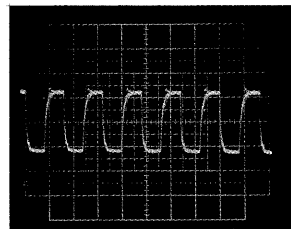

⑧ IC702 ② pin (BCK)  
5.2Vp-p, 0.3μs

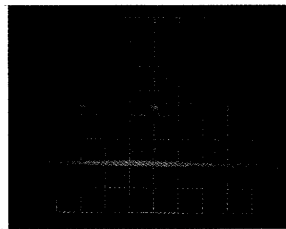

⑬ IC01 ⑦ pin,  
IC311 ⑤ pin (DPG)  
PLAY mode  
5Vp-p, 10ms

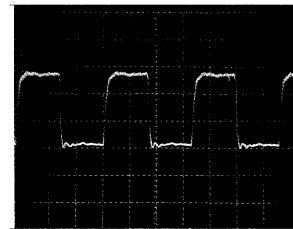

⑱ IC307 ⑦ pin (BCK)  
5.2Vp-p, 0.1μs

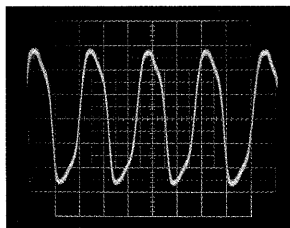

④ IC701 ③ pin (XTAL)  
5.5Vp-p, 2.5μs

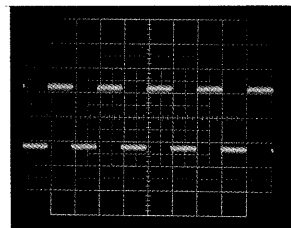

⑨ IC702 ③ pin (LRCK)  
5.7Vp-p, 20μs

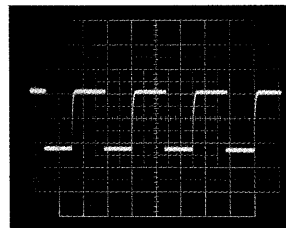

⑭ IC01 ③ pin,  
IC311 ⑤ pin (DFG)  
PLAY mode  
5Vp-p, 1.25ms

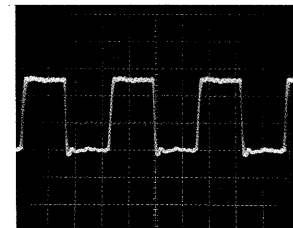

⑲ IC307 ⑦ pin,  
IC359 ⑮ pin (XBCK),  
IC363 ⑧ pin (BCKI)  
5.4Vp-p, 0.1μs

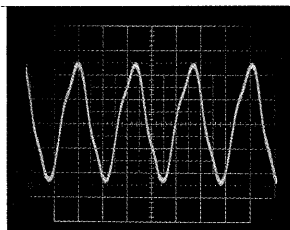

⑤ IC701 ③ pin (EXTAL)  
5Vp-p, 2.5μs

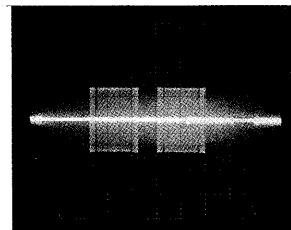

⑩ IC1 ⑦ ③ pin (HEAD)  
REC mode 4.2Vp-p

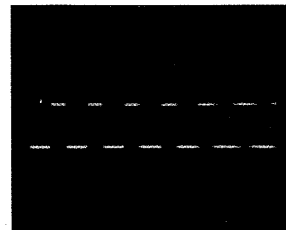

⑮ IC03 ①, ⑦ pin,  
IC311 ⑤, ⑤ pin  
(FGS, FGT)  
FF, REW mode 3.6Vp-p, 0.1ms

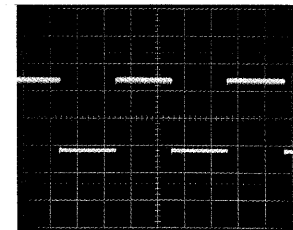

⑳ IC307 ⑦ pin (LRCK)  
5.6Vp-p, 5μs

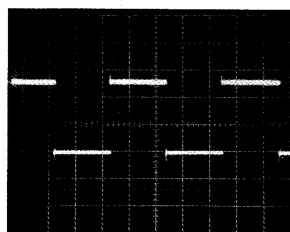

21 IC307 69 pin, IC359 14 pin (LR03)  
5.6Vp-p, 5μs

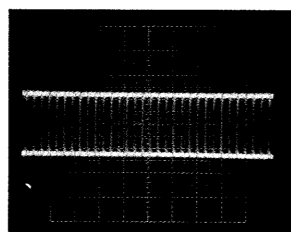

26 IC307 54 pin (TX)  
PLAY mode  
5.3Vp-p, 0.2s

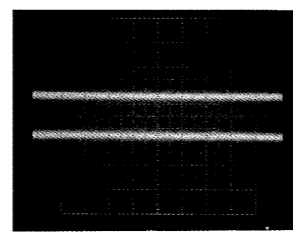

31 IC307 37 pin, IC311 22 pin (RFDT)  
PLAY mode  
1Vp-p, 10ms

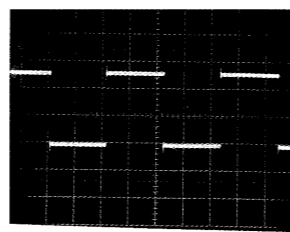

36 IC333 2 pin, IC363 10 pin (LRCKI)  
5Vp-p, 5μs

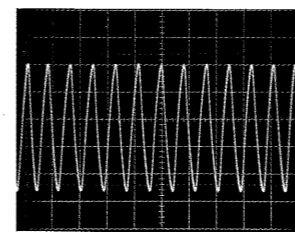

41 IC601 40 pin, IC363 17 pin (512FS)  
4.5Vp-p, 50ns

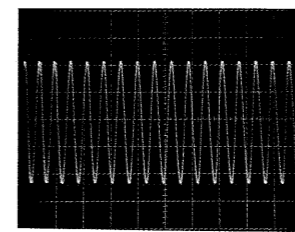

46 Q502 Source (VCO)  
2.3Vp-p, 50ns

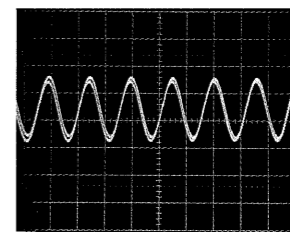

51 IC330 16 pin (XIN)  
1.2Vp-p, 20μs

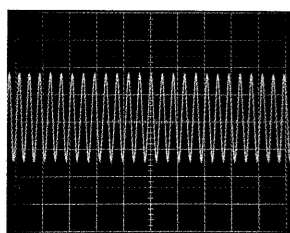

22 IC307 37 pin (XT3I)  
0.9Vp-p, 50ns

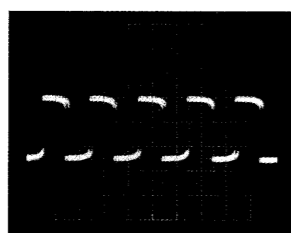

27 IC307 50 pin (RX)  
5.2Vp-p, 0.5ms

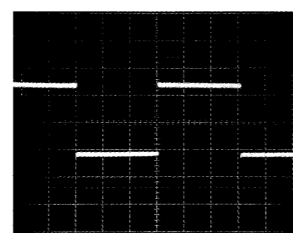

32 IC307 21 pin, IC311 60 pin (DREF)  
5Vp-p, 5ms

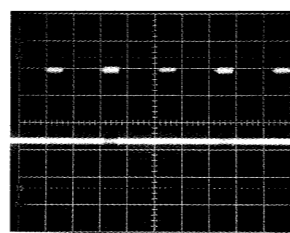

37 IC306 1 pin, IC363 9 pin (DATAI)  
5Vp-p, 5μs

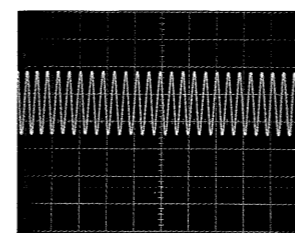

42 IC601 10 pin (1024FS)  
2.4Vp-p, 50ns

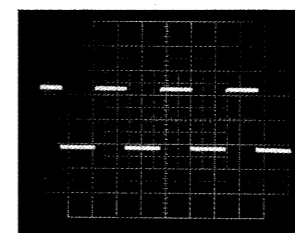

47 IC311 24 pin (D PWM)  
PLAY mode  
5Vp-p, 10μs

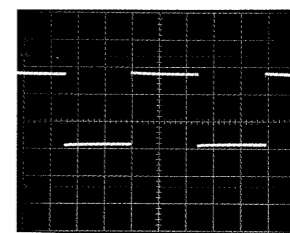

52 IC330 15 pin (XINTR)  
5.2Vp-p, 0.1μs

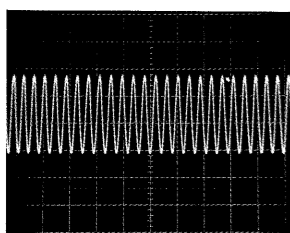

23 IC307 66 pin (X3TO)  
2.9Vp-p, 50ns

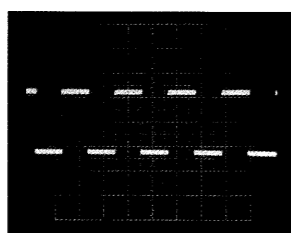

28 IC307 48 pin (PLCO)  
4.8Vp-p, 0.18ms



33 IC307 20 pin, IC311 35, 61 pin, IC312 35 pin (MCLK)  
5.8Vp-p, 50ns



38 IC363 20, 21 pin (DL, DR)  
6Vp-p, 50ns

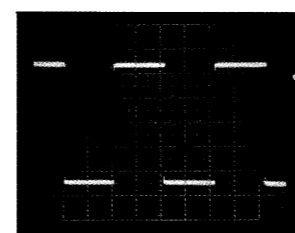

43 IC504 7 pin (LRCKI)  
4Vp-p, 5μs

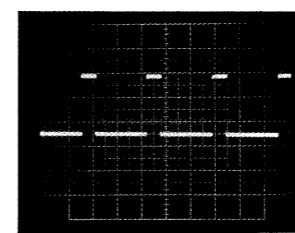

48 IC311 65, 66 pin (C PWM, PWMR)  
PLAY mode  
5Vp-p, 10μs

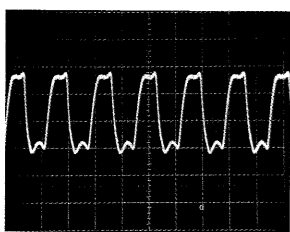

24 IC307 39 pin, IC359 20 pin (F256)  
6.1Vp-p, 50ns

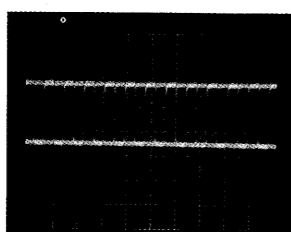

29 IC307 43 pin (REDT)  
REC mode  
4.4Vp-p, 0.5μs

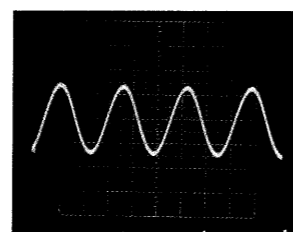

34 IC307 14 pin, (XT1I)  
5.6Vp-p, 50ns

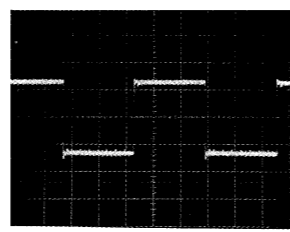

39 IC363 22 pin, IC601 36 pin (LRCK)  
5.3Vp-p, 0.5μs

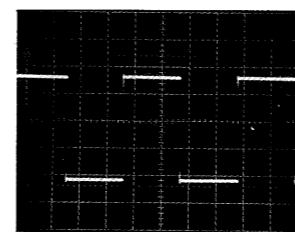

44 IC504 8 pin (1/512FS)  
4Vp-p, 5μs

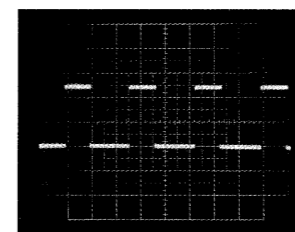

49 IC311 67, 68 pin (TEN PWM, AGC PWM)  
PLAY mode  
5Vp-p, 10μs

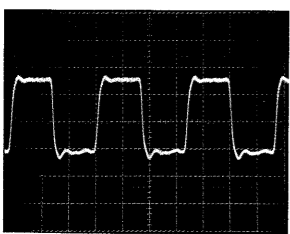

25 IC307 38 pin (F128)  
6Vp-p, 50ns

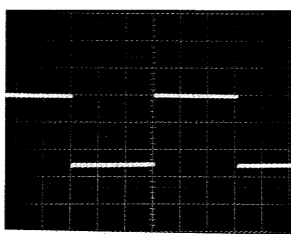

30 IC307 39 pin, IC311 38 pin (SWP)  
PLAY mode  
5.2Vp-p, 50ms

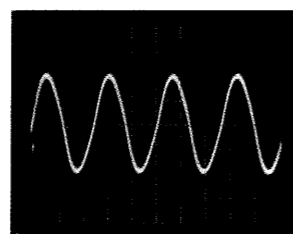

35 IC307 13 pin, (XT1O)  
4Vp-p, 50ns

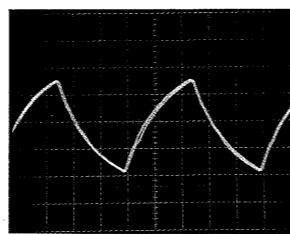

40 IC501 10 pin, IC601 45 pin (128FS)  
3.4Vp-p, 50ns

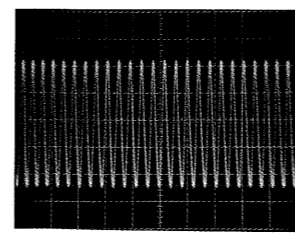

45 Q501 Source (VCO)  
1.2Vp-p, 50ns

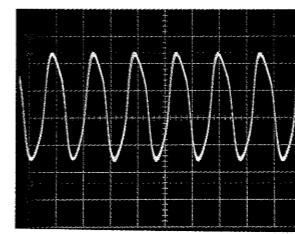

50 IC330 17 pin (XOUT)  
2Vp-p, 20μs

**4-4. SEMICONDUCTOR LEAD LAYOUTS**

**C55339-KP**

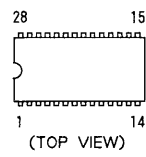

**CX20115A  
SN74HC4020ANS**

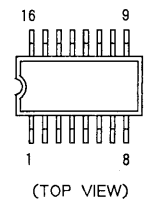

**CXA1364R**

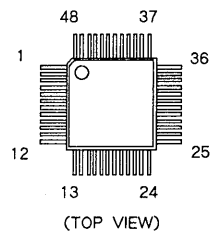

**CXD1136Q**

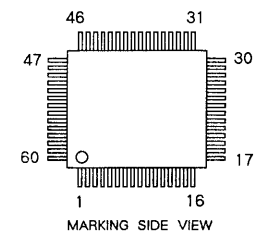

**CXD2560M**

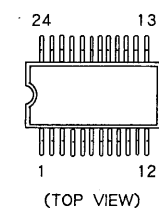

**CXD2562Q**

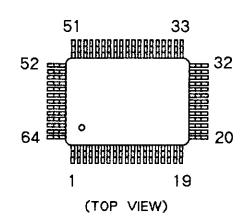

**CXD2601AQ**

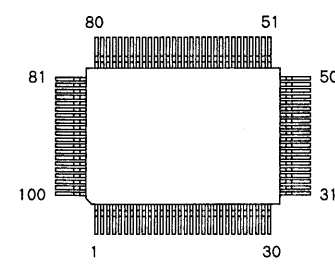

**CXK1011P**

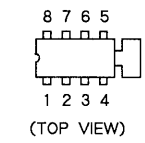

**CXK58257AM-12L**

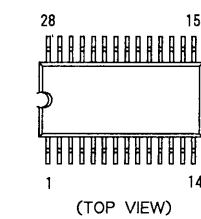

**CXP5058H-659Q  
CXP80524-062Q  
CXP80524-063Q**

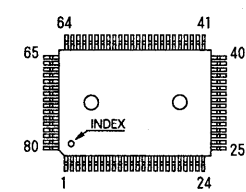

**LF412CN  
M5238P  
NE5532P  
RC4558P  
μPC358C**

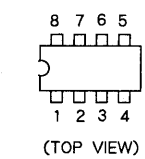

**LM324N  
SN74HC00ANS  
SN74HC04ANS  
SN74HC10ANS  
SN74HC74ANS**

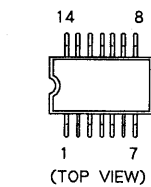

**LM358M**

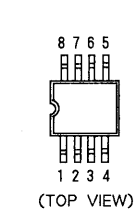

**M5218AL  
M54641L**

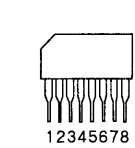

**MSM6338RS**

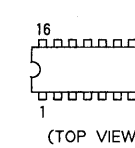

**M5F7808  
TA7805S  
TA7812S  
μPC2406HF**

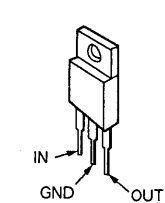

**PST572C  
PST572E**

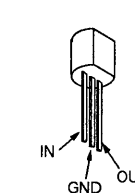

**RP5C62**

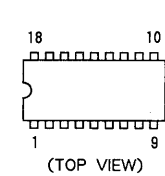

**SN74HC00AN  
SN74HCU04AN  
SN74HC86AN  
SN74LS624N  
μPD4011BC**

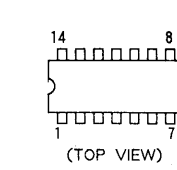

**TA79005S  
TA79012S**

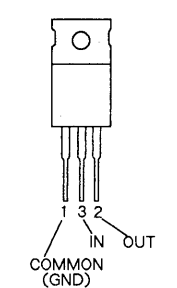

**TC5081AP**

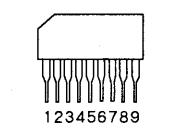

**DTA114ES  
DTC114ES  
2SC2603-EF**

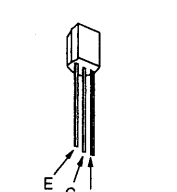

**2SA1175-HFE  
2SC3623A-K**

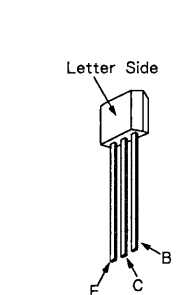

**2SA1585S-QR  
2SC4115S-QR**

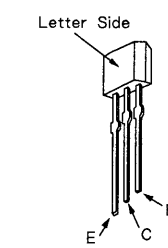

**2SB734-34  
2SB774-34**

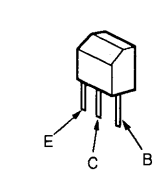

**2SB798-DL**

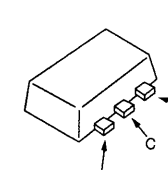

**2SB1094-LK  
2SD2012**

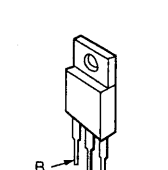

**2SC1623-L5L6**

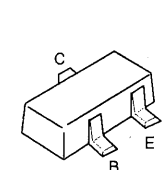

**2SC2021-Q**

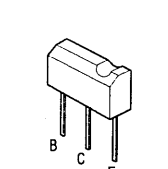

**2SD1387-3**

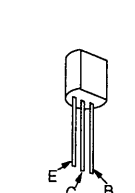

**2SK241-GR**

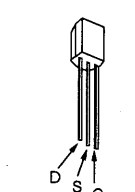

**GL-453S**

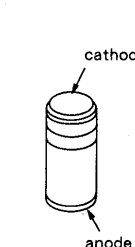

**GP2509-C**

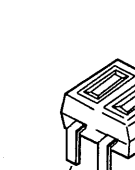

**HZS6A1L  
HZS24-3L  
RD4.7JS-B3  
RD5.1JS-B2  
1SS106  
1SS168  
1SS202-1  
10E2N  
11ES2**

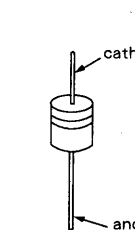

**KV1310**

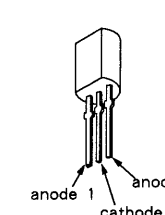

**RBA406B**

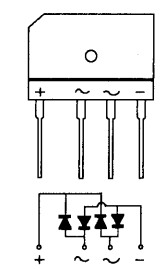

**PT4850F**

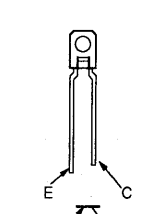

**LN01401C(Q)-3-LF**

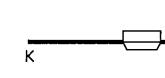

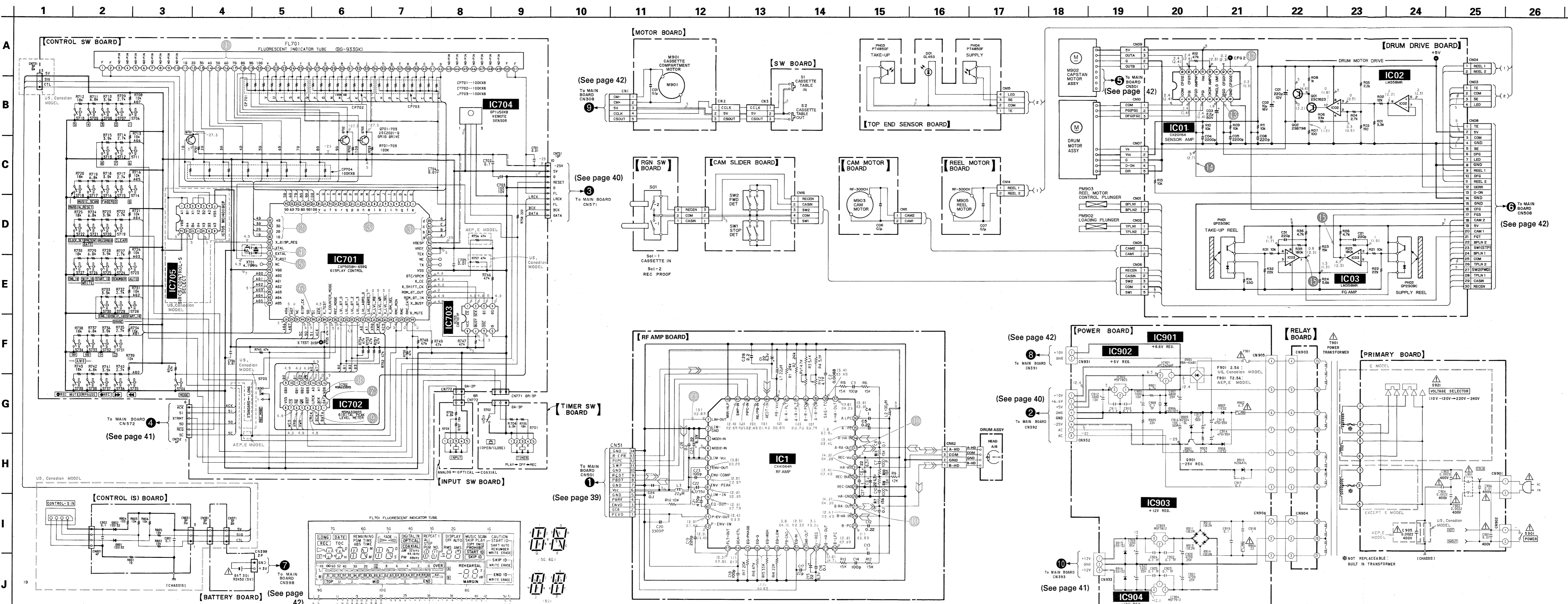

Notes on schematic diagram:

- All capacitors are in  $\mu\text{F}$  unless otherwise noted. pF:  $\mu\text{F}$  50WV or less are not indicated except for electrolytics and tantalums.
- All resistors are in ohms, 1/4W or less unless otherwise noted.
- $\Delta$ : Internal component
- $\text{---}\text{---}\text{---}$ : Fuse resistor

The components identified by mark  $\Delta$  or dotted line with mark  $\Delta$  are critical for safety. Replace only with part number specified.

Les composants identifiés par une marque  $\Delta$  sont critiques pour la sécurité. Ne les remplacer que par une pièce portant le numéro spécifié.

- $\text{---}\text{---}\text{---}$ : B+ Line
- $\text{---}\text{---}\text{---}$ : B- Line
- Voltage are dc with respect to ground under no-signal (STOP) conditions.
- No mark: Stop
- ( ): PLAY
- ( ( ) ): REC
- < > : FF
- << >> : REW
- [ ] : MOMENTARILY WHEN  $\text{---}\text{---}\text{---}$  and  $\text{---}\text{---}\text{---}$  BUTTON IS PRESSED.
- [ [ ] ] : MUTING
- Voltages are taken with a VOM (input impedance 10M $\Omega$ ).
- Voltage variations may be noted due to normal production tolerances.
- Circled numbers refer to waveforms.
- Waveforms are taken with an oscilloscope.
- Voltage variations may be noted due to normal production tolerances.
- Signal path
- $\text{---}\text{---}\text{---}$ : PB
- $\text{---}\text{---}\text{---}$ : REC







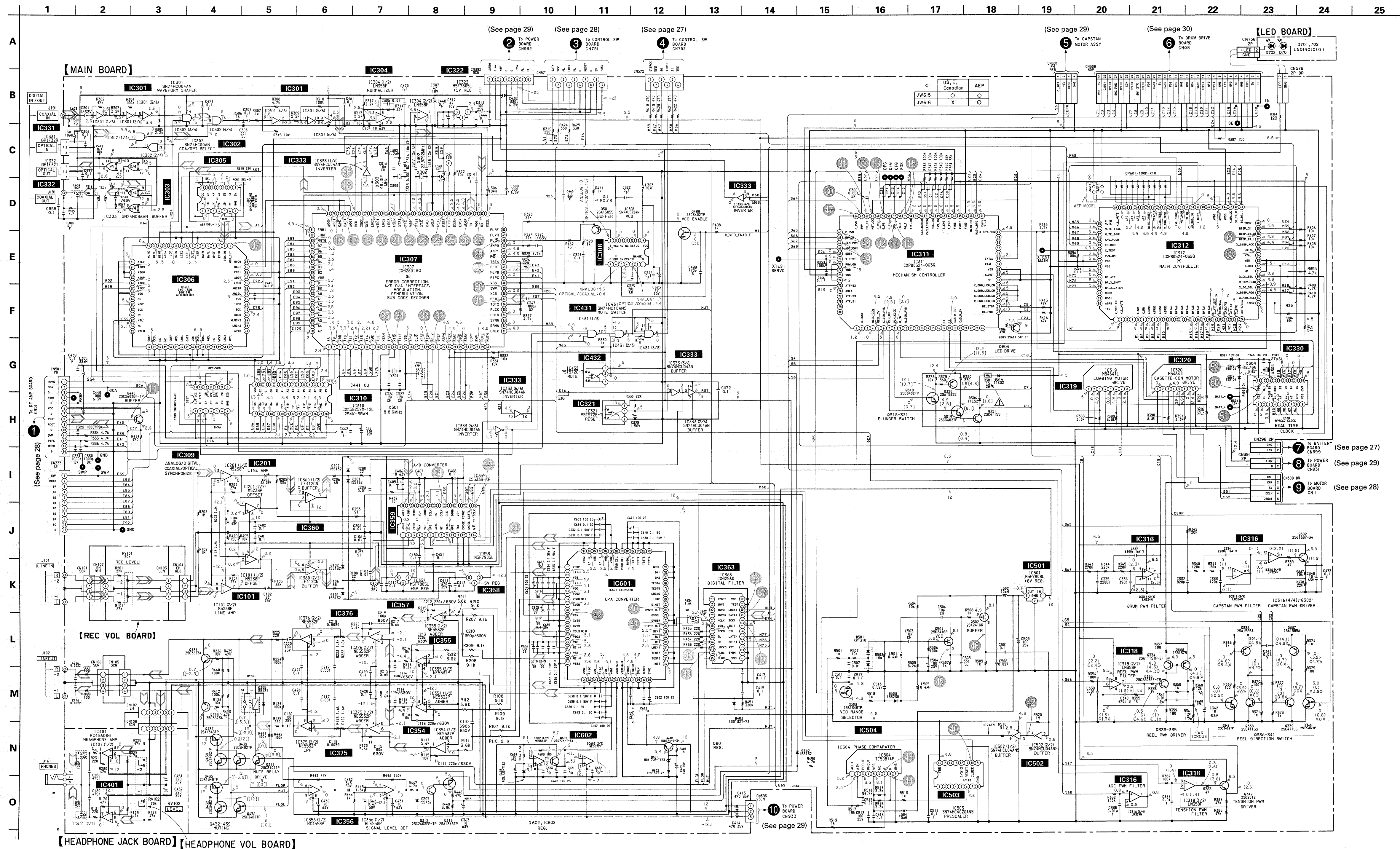

**Notes on schematic diagram:**

- All capacitors are in  $\mu\text{F}$  unless otherwise noted. pF:  $\mu\text{F}$  50WV or less are not indicated except for electrolytics and tantalums.
- All resistors are in ohms, 1/4W or less unless otherwise noted.
- $\Delta$ : Internal component
- %: Indicate a permissible margin
- W: Nonflammable resistor

The components identified by mark  $\Delta$  or dotted line with mark  $\Delta$  are critical for safety. Replace only with part number specified.

Les composants identifiés par une marque  $\Delta$  sont critiques pour la sécurité. Ne les remplacer que par une pièce portant le numéro spécifié.

—: B+ Line  
 - - - - -: B- Line  
 [ ]: Adjustment for repair  
 ~: Voltage are dc with respect to ground under no-signal (STOP) conditions.  
 No mark: Stop  
 ( ): PLAY  
 ( [ ] ): REC  
 < >: FF  
 << >>: REW  
 [ ]: MOMENTARILY WHEN << and >> BUTTON IS PRESSED.  
 [ ]: MUTING  
 Voltages are taken with a VOM (input impedance 10M $\Omega$ ). Voltage variations may be noted due to normal production tolerances.  
 Circled numbers refer to waveforms.  
 Waveforms are taken with an oscilloscope. Voltage variations may be noted due to normal production tolerances.  
 Signal path  
 ~: REC

4-9. IC BLOCK DIAGRAMS

• DRUM DRIVE board  
IC01 CX20115A

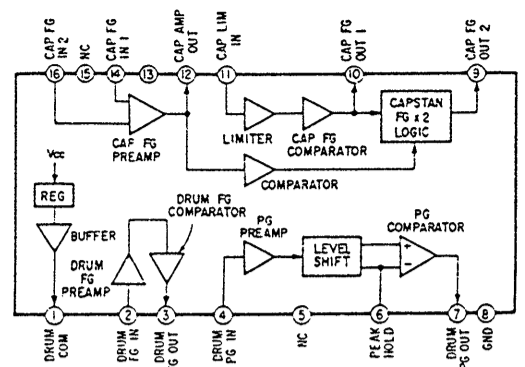

• RF AMP board  
IC1 CXA1364R

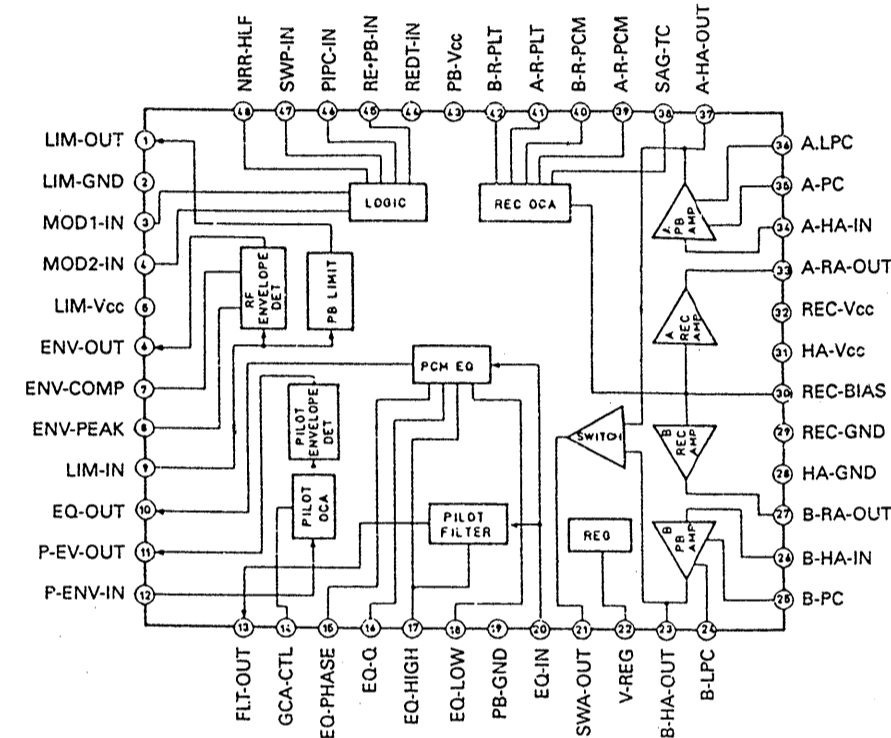

• MAIN board  
IC306 CXD1136Q

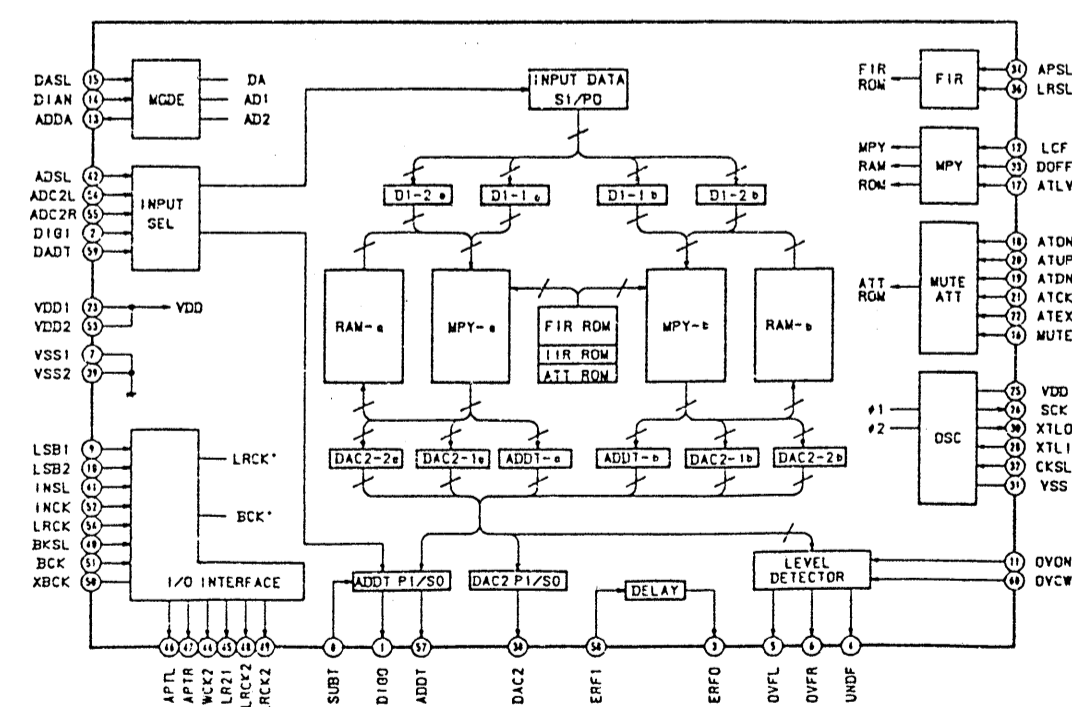

IC307 CXD2601AQ

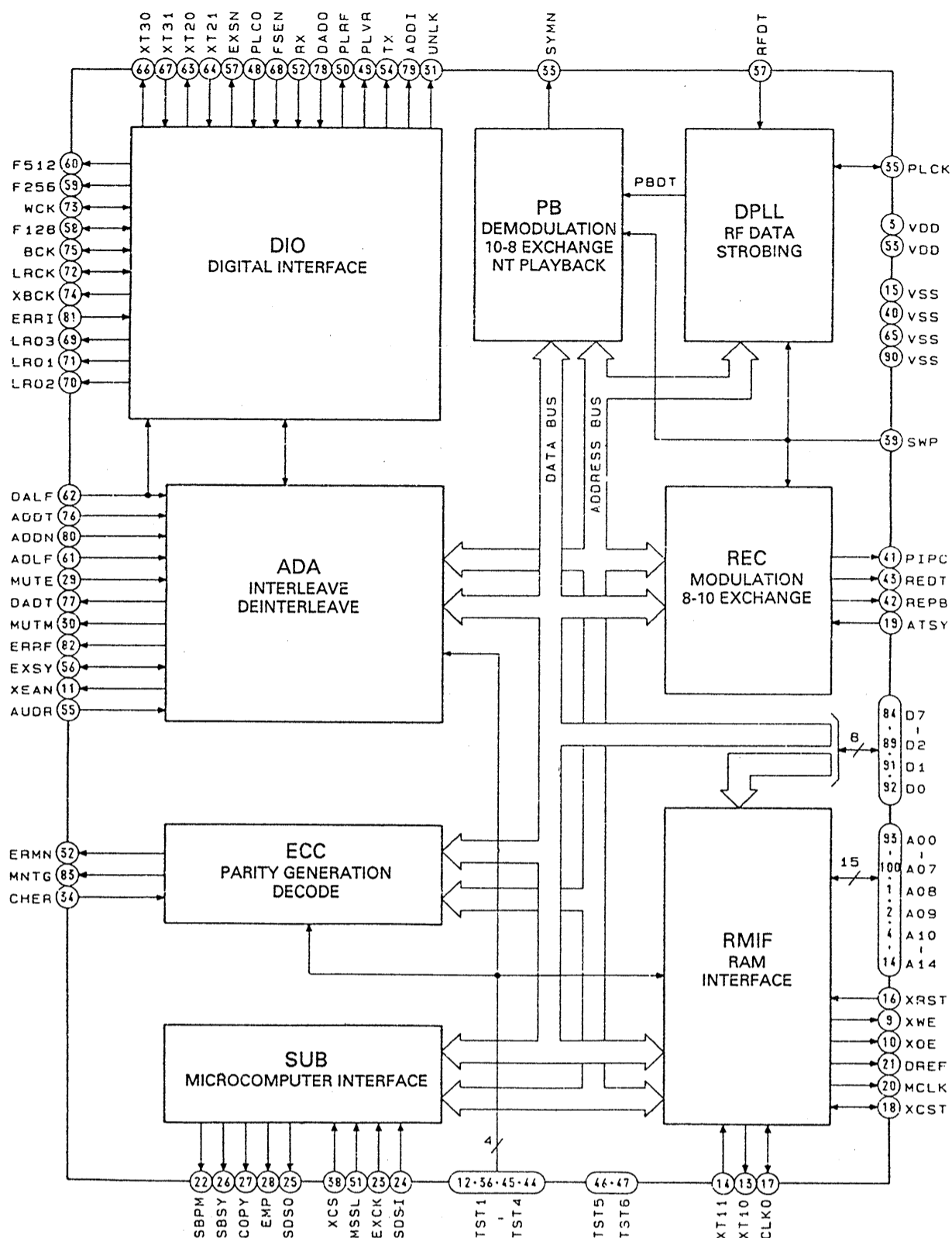

IC308 SN74LS624N

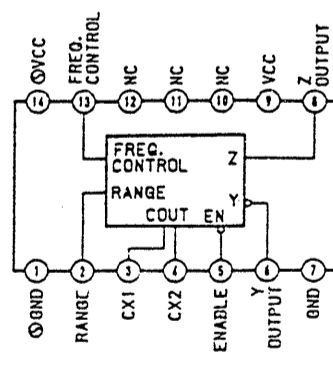

IC309 SN74HC74ANS

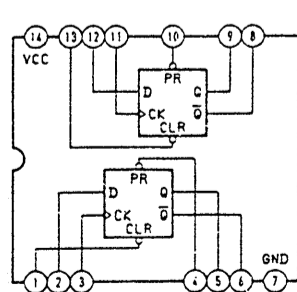

IC319,320 M54641L

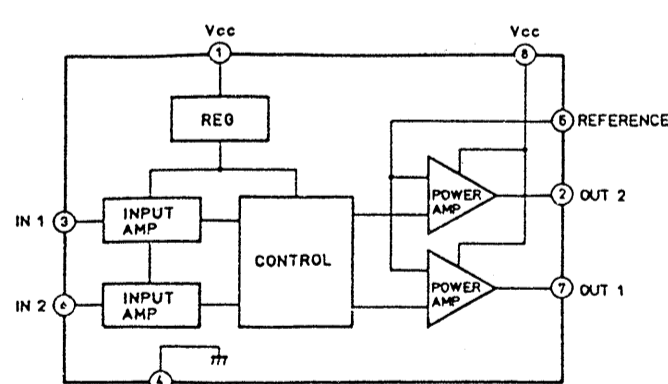

IC359 CS5339-KP

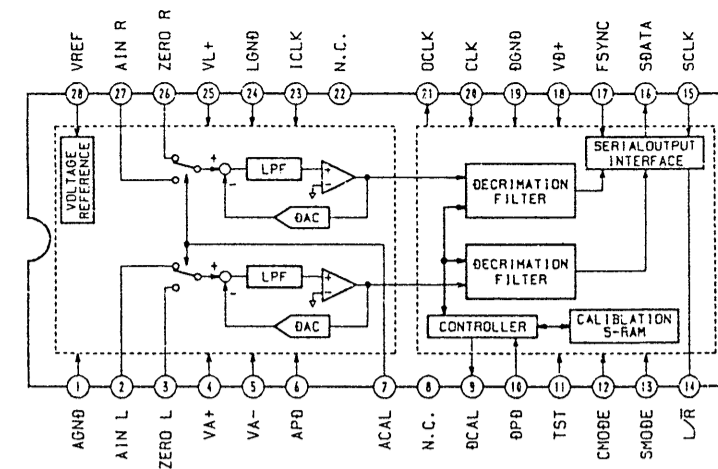

IC363 CXD2560M

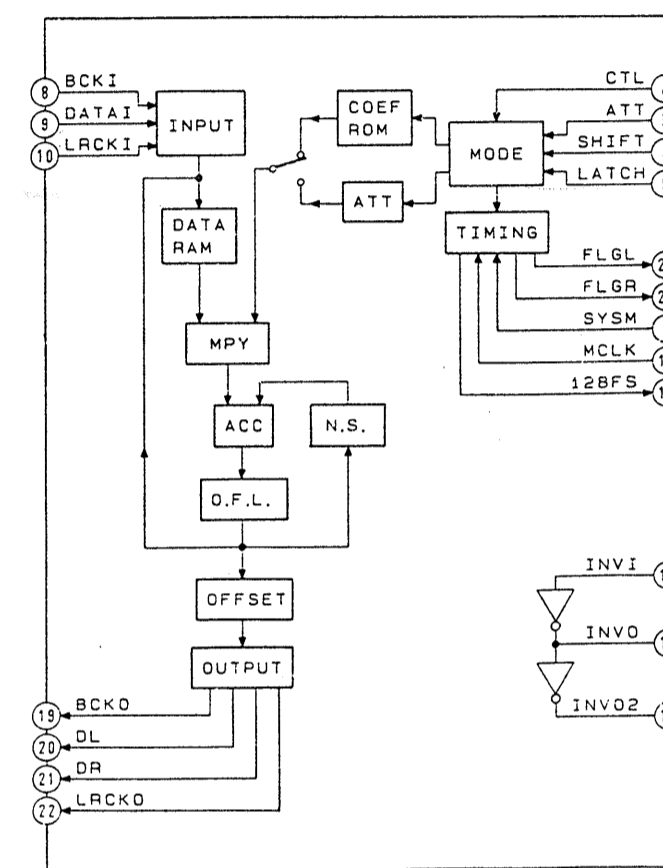

IC601 CXD2562Q

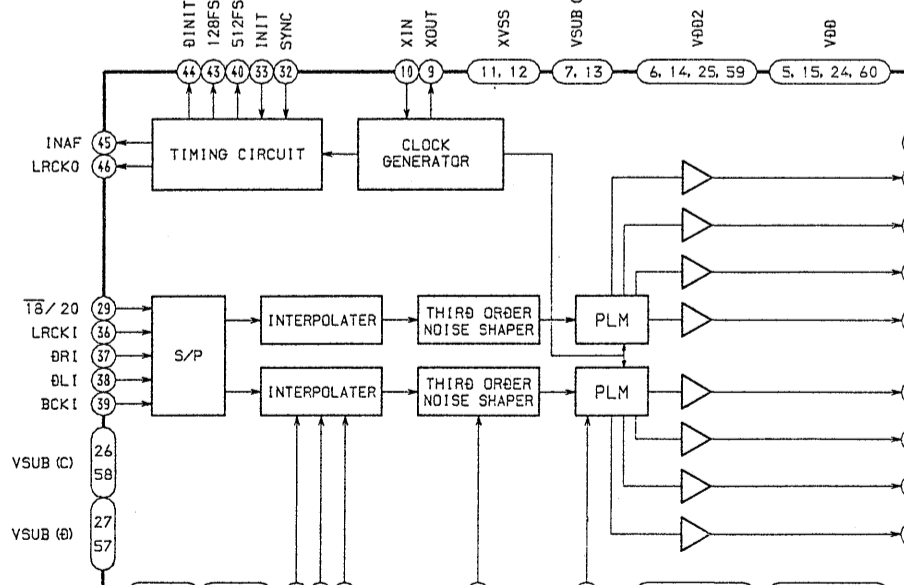

IC504 TC5081AP

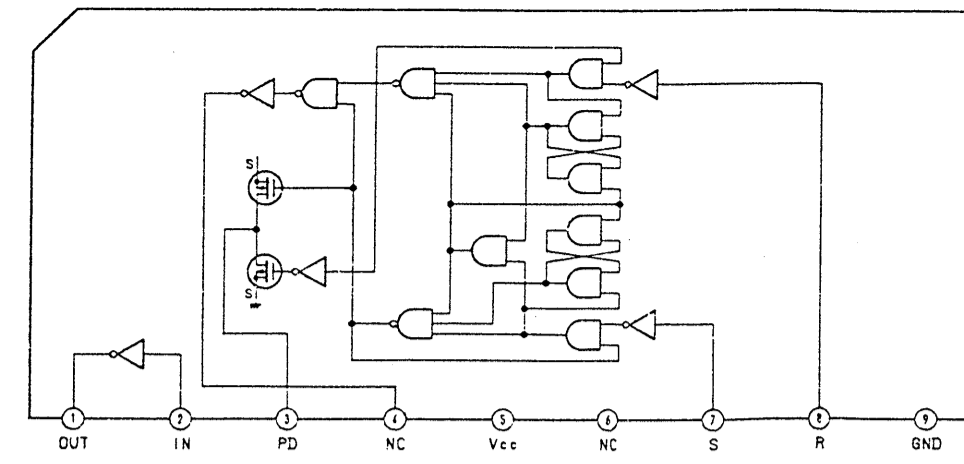

4-10. PIN FUNCTIONS

IC306 Digital Attenuator (CXD1136Q)

The captioned attenuator is used with the equipment as a digital attenuator in fade IN and fade OUT.

Pin No.	Pin Name	I/O	Description
1	DIGO	O	Serial data output synchronized with BCK (complement of 2)
2	DIGI	I	Serial data input synchronized with BCK (complement of 2)
3	ERFO	O	Signal output for discriminating whether or not DADT has interpolated data (Not in use)
4	UNDF	O	Detect result for ADDT L, R channel data of -54 dB or less ("L": -54 dB or less) (Not in use)
5	OVFL	O	Detect result for ADDT L channel overflow ("L": overflow detected) (Not in use)
6	OVFR	O	Detect result for ADDT R channel overflow ("L": overflow detected) (Not in use)
7	VSS	—	GND
8	SUBT	I	Selects whether subcode or 18-bit data is output to ADDT and DIGO ("H" or open: 18-bit data output, "L": subcode output)
9	LSB1	I	MSB/LSB fast switching for DADT, ADDT, D/GI, DIGO ("H" or open MSB fast, L: LSB fast)
10	LSB2	I	MSB/LSB fast switching for DAC2, ADC2L (ADC2R) ("H" or open MSB fast, L: LSB fast)
11	OVON	I	Overflow detect result on/off ("H" or open: OVFL, OVFR output valid, L: OVFL, OVFR fixed "H")
12	LCF	I	Low-cut filter on/off ("H" or open: on)
13	ADDA	O	"H" in AD mode (DASL = DIAN = "L") (Not in use)
14	DIAN	I	Sets AD and DA modes
15	DASL	I	Sets AD and DA modes
16	MUTE	I	Soft muting on/off ("H": mute on)
17	ATLV	I	Digital volume range setting ("H" or open: 0 - -60, -∞ dB, "L": +12 - -48, ∞ dB)
18	ATON	I	Digital volume on/off ("H" or open: off)
19	ATDN	I	Digital volume level down
20	ATUP	I	Digital volume level up
21	ATCK	I	Digital volume level setting clock and soft muting external clock
22	ATEX	I	Soft muting operation clock selection ("H" or open: internal clock, "L": ATCK)
23	VDD	—	Power supply (+5 V)
24	NC	—	Oscillator circuit power supply (+5 V)
25	VDD	—	Oscillator circuit power supply (+5 V)
26	SCK	O	Oscillator clock output (Not in use)
27	NC	—	Crystal connector and clock input pin
28	XTLI	I	Crystal connector and clock input pin
29	NC	—	Crystal connector pin (24.576 MHz oscillation frequency possible) (Not in use)
30	XTLO	O	Crystal connector pin (24.576 MHz oscillation frequency possible) (Not in use)
31	VSS	—	Oscillator circuit GND
32	CKSL	I	Oscillator clock division selection ("H" or open: no division, "L": 1/2 division)
33	NC	—	
34	NC	—	
35	DOFF	I	DAC2 digital offset on/off ("H" or open: on) (Not in use)
36	APSL	I	Aperture correction filter coefficient selection (not valid in AD mode) ("H" or open: correction active)
37	LRSL	I	L, R channel phase difference correction selection ("H" or open: correction active) (Not in use)
38	DAC2	O	Serial data output to 2-times oversampling DA converter (complement of 2) (Not in use)
39	VSS	—	Power supply (+5 V)
40	BKSL	I	LRCK, BCK input timing switch ("H" or open: LRCK change point and BCK leading edge synchronized, "L": LRCK change point and BCK trailing edge synchronized)
41	INSL	I	DADT, DIGI, ADC2L (ADC2R) data incorporation clock selection ("H" or open: BCK, "L": INCK)
42	ADSL	I	ADC2L, ADC2R data selection ("H" or open: ADC2L, "L": ADC2L and ADC2R switched by LRCK2)
43	NC	—	
44	WCK2	O	Clock equivalent to 4fs (Not in use)
45	LR21	O	DAC2 L, R channel discrimination signal in FS format (Not in use)

Pin No.	Pin Name	I/O	Description
46	APTL	O	Aperture signal (Not in use)
47	APTR	O	Aperture signal (Not in use)
48	LRCK2	O	DAC2, ADC2L (ADC2R) L, R channel discrimination signal (equivalent to 2fs) ("L": L channel, "H": R channel) (Not in use)
49	XLRCK2	O	LRCK2 inverted output (Not in use)
50	XBCK	O	BCK inverted output (Not in use)
51	BCK	I	Clock equivalent to 64fs for DADT, ADDT, DIGI, DIGO data incorporation
52	INCK	I	DADT, DIGI, ADC2L (ADC2R) data incorporation clock
53	VDD	—	Power supply (+5 V)
54	ADC2L	I	Serial data input from 2-times oversampling AD converter (complement of 2)
55	ADC2R	I	Serial data input from 2-times oversampling AD converter (complement of 2)
56	LRCK	I	DADT, ADDT, DIGI, DIGO L, R channel discrimination signal (fs) ("L": L channel, "H": R channel)
57	ADDT	O	Serial data output synchronized with BCK (complement of 2)
58	ERFI	I	Signal input for discriminating whether or not DADT has interpolated data (complement of 2)
59	DADT	I	Serial data input synchronized with BCK (complement of 2)
60	OVCW	I	Clock input which determines detect time for OVFL, OVFR and UNDF

**IC307 DAT Signal Processor (CXD2601AQ)**

This processor is an LSI to process recording and playback signals of the R-DAT system, in a single chip and provided with digital PLL, modem, error correction circuit, digital I/O, RAM control circuit, etc.

Pin No.	Pin Name	I/O	Description
1, 2 3	A08, A09 VDD	I/O —	RAM address A08, A09 5 V
4-6 7, 8 9	A10-A12 A13, A14 XWE	I/O O O	RAM address A10-A12 RAM address A13, A14 RAM write enable signal
10 11 12 13 14	XOE XEAN TST1 XT1O XT1I	O O I O I	RAM output enable signal External addressing bus interrupt enable signal (Not in use) Test pin (normally "L") 18.816 MHz crystal oscillator output 18.816 MHz crystal oscillator input
15 16 17 18 19	VSS XRST CLKO XCST ATSY	— I I/O I/O I	GND Reset pin (normally "H") 18.816 MHz clock output (Not in use) SYEK (internal system clock) generation CLKO division timing signal (Not in use) ATF sync signal input
20 21 22 23 24	MCLK DREF SBPM EXCK SDSI	O O O I I	9.408 MHz clock output Drum servo reference signal Discrimination signal determining whether the subcode I/O clock (EXCK) is accepted ("L": accept, "H": ignore) (Not in use) Subcode I/O data transfer clock (DUTY50) Subcode serial data input
25 26 27 28 29	SDSO SBSY COPY EMP MUTE	O O O O I	Subcode serial data output Subcode I/O sync signal Copy data output (Not in use) Emphasis data output (Not in use) Mute pin
30 31 32 33 34	MUTM UNLK ERMN SYMN CHER	O O O O I	Mute discrimination signal ("H": muted) RX PLL lock discrimination signal ("H": locked) Detects presence or absence of RF ("H": RF present, "L" during REC) C1 check result for RF ("H": OK) (Not in use) Signal for discriminating whether C2 is 1 or 2 times (C2 → C1 → C2 or C1 → C2) ("H": 1 time, "L": 2 times) (Not in use)
35 36 37 38 39	PLCK TST2 RFDT XCS SWP	I/O I I I I	RF PLL clock output (Not in use) Test pin (normally "L") RF signal input Subcode I/O chip select ("L": select) RF switching pulse ("L": A-CH, "H": B-CH)
40 41 42 43 44	VSS PIPC REPB REDT TST4	— O O O I	GND REC data PILOT/PCM discrimination signal ("H": PILOT, during playback: always "L") Record/playback switching signal ("H": record) Recording signal output, fixed "L" during playback Test pin (normally "L")
45 46 47 48	PDO AMPI AMPO PLCO	O I O I	RX APLL PD output (comparator output) RX APLL oscillator cell amp input RX APLL oscillator cell amp inverted output RX APLL external VCO clock input

Pin No.	Pin Name	I/O	Description
49	PLVR	O	RX APLL comparison signal when external comparator is active (Vin) Not in use
50	PLRF	O	RX APLL comparison signal when external comparator is active (Rin) Not in use
51	MSSL	I	Master/slave setting (“H”: master (fixed with the equipment), “L”: slave)
52	RX	I	Digital input
53	VDD	—	5 V
54	TX	O	Digital output
55	AUDR	I	Audio mode/data recorder mode setting (“H”: audio mode, “L”: data recorder mode)
56	EXSY	I/O	Complete copy sync signal (25/3 - 100/3 Hz)
57	EXSN	I/O	Complete copy sync signal (25/3 - 100/3 Hz)
58	F128	I/O	128fsCK (normal)/256fsCK (×2) (DUTY50)
59	F256	O	256fsCK (normal)/512fsCK (×2) (DUTY50)
60	F512	O	512fsCK (normal)/512fsCK (×2) (DUTY50)
61	ADLF	I	Signal for discriminating whether ADDT serial data is MSB first or LSB first (“H”: LSB first)
62	DALF	I	Signal for discriminating whether DADT serial data is MSB first or LSB first (“H”: LSB first)
63	XT20	O	22.5792 MHz crystal oscillator output
64	XT21	I	22.5792 MHz crystal oscillator input
65	VSS	—	GND
66	XT30	O	49.152 MHz crystal oscillator output (24.576 MHz in B mode)
67	XT31	I	49.152 MHz crystal oscillator input (24.576 MHz in B mode)
68	FSEN	I	F128, BCK, LRCK input/output switch (“H”: output)
69	LR03	O	LR02 inversion
70	LR02	O	LRCK 16BCK delay signal
71	LR01	O	LRCK 15BCK delay signal
72	LRCK	I/O	fs (normal)/2fs (×2) (“L”: L-CH, “H”: R-CH)
73	WCK	I/O	2fs (normal)/4fs (×2) (input mode only for testing)
74	XBCK	O	BCK inversion
75	BCK	I/O	64fs (normal)/128fs (×2)
76	ADDT	I	Serial AD data (complement of 2)
77	DADT	O	Serial DA data (complement of 2)
78	DADO	I	Digital output (DA) data input (normally connected to DADT)
79	ADDI	O	Digital input (AD) data output (normally connected to ADDN)
80	ADDN	I	Digital input (DA) data input
81	ERRI	I	Digital output V-FLAG data input (normally connected to ERRF)
82	ERRF	O	Signal output for discriminating whether or not DADT has interpolated data (“H”: interpolated data)
83	MUTG	O	Error correction status monitor trigger
84-89	D7-D2	I/O	RAM data bus D7-D2
90	VSS	—	GND
91, 92	D1, D0	I/O	RAM data bus D1, D0
93-100	A00-A07	I/O	RAM address A00-A07

**IC311 Mechanism/Servo Micon (CXP80524-063Q)**

The mechanical deck servo systems are controlled by the captioned micon according to instructions from the main micon (IC312).

Pin No.	Pin Name	I/O	Connected to	Description
1		O		Not in use
2	BUSY	O	Main Micon	Busy (Active "L") to the Main Micon
3		O		Not in use
4	REEL_CCW	O	Mechanism	Reel motor CCW ("L": RVS direction) } *1
5	REEL_CW	O	Mechanism	
6	C_DIR_RVS	O	Mechanism	Capstan Direction ("L": FWD, "H": RVS)
7	PLN_ON	O	Mechanism	Plunger On
8	PLN_KICK	O	Mechanism	Plunger Kick
9	D_ON	O	Mechanism	Drum On ("H": The drum is revolving)
10	D_DIR_RVS	O	Mechanism	Not in use
11-16		O		Not in use
17	LE	O	Mechanism	Loading Motor Eject } *2
18	LL	O	Mechanism	
19	CAS_M_OUT	O	Mechanism	Cassette control motor Out } *3
20	CAS_M_IN	O	Mechanism	
21-24		—		Not in use
25	RE_FWD	I	Mechanism	Encoder SW2 } *4
26	RE_STOP	I	Mechanism	
27-30	END_LED_ON	O	Mechanism	End sensor ON Illuminated upon "L" (rectangular wave of about 1kHz). It is not output unless a cassette is mounted ("H").
31	MP	I		Microprocessor mode selected (the equipment is fixed at "L").
32	RST	I		System Reset (low active)
33	Vss	—		Power terminal (GND)
34	XTAL	O		System Clock Output (Not in use)
35	EXTAL	I	CXD2601AQ	System Clock Input (9.408 MHz)
36-39		—		Not in use
40	X_SRV_REQ	I	Main Micon	Request for communication from the Main Micon
41	MAIN_DT_I	I	Main Micon	Serial Input from the Main Micon
42	MAIN_DT_O	O	Main Micon	Serial Output to the Main Micon
43	MAIN_CK	I	Main Micon	Serial Clock with the Main Micon
44	AVss	—		GND for A/D
45	AVref	—		Reference Voltage for A/D (+5 V)
46	AVdd	—		Power Supply for A/D (+5 V)
47	T_END	I	Mechanism	Take-up side end sensor input (analog) } Magnetic matter: 0V, Supply side end sensor input (analog) } Leader tape: AC (*5)
48	S_END	I	Mechanism	
49	CAS_IN	I	Mechanism	Cassette-in switch (S01). "H": Cassette is mounted.
50	REC_EN	I	Mechanism	Rec-enable switch (S01). "H": REC enabled.
51	CAS_LCKed	I	Mechanism	Casecon locked Upon completion of loading: "H"
52	CAS_OUTed	I	Mechanism	Casecon outed Upon completion of loading OUT: "H"
53		I		Not in use
54	ATF_IN	I	RF Amp	ATF PILOT input
55	FG_T	I	Mechanism	Reel FG (T Side) } 6/24Hz (Small reel diameter) - Reel FG (S Side) } 15/24Hz (Large reel diameter) (In SP FWD)
56	FG_S	I	Mechanism	
57	C_FG	I	Mechanism	Capstan FG SP: 674 Hz, LP: 337 Hz
58	D_FG	I	Mechanism	Drum FG 400 Hz: LP REC, 800 Hz: Other modes
59	D_PG	I	Mechanism	Drum PG } Other than LP REC: 800/24Hz
60	D_REF	I	CXD2601AQ	

Pin No.	Pin Name	I/O	Connected to	Description
61	MST_CK	I	CXD2601AQ	Master clock (9.408MHz)
62	PB_DT	I	RF Amp	PB Data input to create ATF Sync
63	SWP	O	CXD2601AQ	Switching Pulse "L": Ach, "H": Bch
64	D_PWM	O	Mechanism	PWM Out for Drum
65	C_PWM	O	Mechanism	PWM Out for Capstan
66	PWM_R	O	Mechanism	PWM Out for Reel
67	TEN_PWM	O	Mechanism	PWM Out for Tension Regulator Plunger
68	AGC_PWM	O	RF Amp	PWM Out for AGC
69	SBSY	I	CXD2601AQ	↓ of subsync is detected (XINT2).
70	TEST	I	Pull-up	Test Mode (active "L")
71	POW_DN	I		Not in use
72	Vdd	—		Power terminal (+5 V)
73	Vss	—		Power terminal (GND)
74		—		Not in use
75	ATF_S2	O	CXD2601AQ	ATF Sampling Pulse
76-80		—		Not in use

\*1 Reel motor control

	CCW (counterclockwise)	CW (clockwise)
STOP (only in POWER ON)	L	L
FWD	L	H
RVS	H	L
Prohibit	H	H

\*4 Encoder

RF-FWD	RE_STOP	Position
L	L	EJECT
L	H	STOP UNLD-STOP
H	L	FWD
H	H	STOP-FWD

\*2 Loading motor control

	LE	LL
—	L	L
LOAD	L	H
EJECT	H	L
Brake	H	H

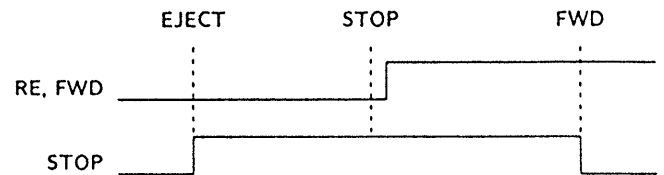

\*3 Casecon motor control

	OUT	IN
—	L	L
IN	L	H
OUT	H	L
Brake	H	H

\*5 End sensor

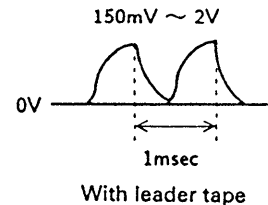



**IC312 Main Micon (CXP80524-062Q)**

This Micon generally controls the operation of the equipment while exchanging data with the display micon (IC701) and mechanism/servo micon (IC311) in serial communications, including the DAT signal processor (IC307), digital filter (IC363) and other IC.

Pin No.	Pin Name	I/O	Connected to	Description
1	VCO EN	O	VCO Circuit	VCO enable out
2	$\overline{\text{L\_MUTE}}$	O	Line Out	Line Mute (Active "L")
3		O		Not in use
4		O		Not in use
5	$\overline{\text{WRT}}$	O	Clock IC	Write request (Active "L")
6	RD	O	Clock IC	Read request (Active "L")
7-10	ADRS_3-0	O	Clock IC	Address 3-0 (Address BUS)
11-14	DATA_7-4	I/O		DATA 7-4 (DATA BUS). Not in use with the equipment
15-18	DATA_3-0	I/O	Clock IC	DATA 3-0 (DATA BUS)
19	$\overline{\text{ATT\_EXT}}$	O	CXD1136Q	Fade attenuator ck externally selected (Active "L")
20	$\overline{\text{DIG/ANA}}$	O	CXD1136Q	Fade In/Out switching for DIG ("L")/ANA ("H")
21	$\overline{\text{REC/PB}}$	O	CXD1136Q	Fade In/Out REC switching for ("L")/PB ("H")
22	$\overline{\text{ATT\_CK}}$	O	CXD1136Q	Clock for fade In/Out
23	$\overline{\text{DTR}}$	O	CXD2601AQ	Audio use ("H")/Data Recorder use ("L"). Becomes "L" in after-recording and searching.
24	$\overline{\text{OPT/COA}}$	O	Digital I/O	Switching for Optical ("L")/Coaxial ("H")
25	FS32	O	1Bit DAC	"H" upon Fs = 32kHz. "L" for others.
26	$\overline{\text{RAM\_SEL}}$	O		Not in use
27	$\overline{\text{DISP\_REQ}}$	O	Display Micon	Request for communication with the Display Micon ("L" Active)
28	$\overline{\text{SD\_SEL}}$	O	CXD2601AQ	Request for communication with CXD2601 ("L" Active)
29	$\overline{\text{SRV\_REQ}}$	O	Mechanism Micon	Request for communication with the Mechanism Micon ("L" Active)
30	$\overline{\text{CLOCK\_SEL}}$	O	Clock IC	Clock IC chip selected
31	MP	I		Microprocessor mode selected (fixed at "L" with the equipment)
32	$\overline{\text{RST}}$	I		System Reset ("L" Active)
33	Vss	—		Power terminal (GND)
34	XTAL	O		System Clock Output (Not in use)
35	EXTAL	I	CXD2601AQ	System Clock Input (9.048 MHz)
36	$\overline{\text{DISP\_ACK}}$	I	Display Micon	ACKnowledge (Active "L")
37	DISP_DT_I	I	Display Micon	Serial Input
38	DISP_DT_O	O	Display Micon	Serial Output
39	$\overline{\text{DISP\_CK}}$	I	Display Micon	Serial clock
40	$\overline{\text{SBSY}}$	I	CXD2601AQ	Subcode sync
41	SR_DT_IN	I	} CXD2601AQ & Mechanism Micon	Serial Data In
42	SR_DT_OUT	O		Serial Data Out
43	$\overline{\text{SR\_CK}}$	I/O		Serial clock (In/Out) to Sub Code Interface
44	AVss	—		GND for A/D
45	AVref	—		Reference Voltage for A/D (+5 V)
46	AVdd	—		Power Supply for A/D (+5 V)
47		I		Not in use
48		I		Not in use
49	$\overline{\text{BUSY}}$	I	Mechanism Micon	Mechanism servo micon Busy (Active "L")
50	AU_BUS_IN	I	Pull-up	Not in use

Pin No.	Pin Name	I/O	Connected to	Description
51	TM_IN	I	Clock IC	TM_OUT for clock IC
52	MUT_MON	I	CXD2601AQ	Mute monitor (Active "H")
53	LVL_SYNC	I	Audio Block	Start ID is written by entering Level Sync Input audio.
54		I		Not in use
55	TRQ_TEST	I	Pull-up	Not in use
56	NO_CAS_TEST	I	Pull-up	Not in use
57	TIME_24/12	I	Pull-up	Time indication "H": 12 hours (AM, PM) "L": 24 hours display
58	DATE_ORDER	I	Pull-up	Order of DATA display "H": Year, month and day "L": Month, day and year
59-62	AF_3-0	I	Pull-up	Not in use
63		O	Pull-up	Not in use
64	L_MUTE	O		Line Mute (Active "L"). Not in use with the equipment (Not in use)
65	TR_MUTE	O	Line Out	Transistor Mute (Active "L")
66	MUTE_1136	O	CXD1136Q	Mute for CXD1136Q (Active "H")
67	MUTE_2601	O	CXD2601AQ	Mute for CXD2601 (Active "H")
68	A_D_PWR_DWN	O	CS5339	A/D Converter Power Down Mode (Active "H"). The AD converter is turned OFF upon digital input/output.
69	ER_MON	I	CXD2601AQ	Error Monitor (Data Valid)
70	TEST	I	Pull-up	Test Mode (Active "L")
71	POW_DN	I	+5 V	Not in use
72	Vdd	—		Power terminal (+5V)
73	Vss	—		Power terminal (GND)
74		—	Pull-up	Not in use
75	D_F_ATT	O	CXD2560M	Communication line (Serial Data) with Digital Filter
76	D_F_SHIFT	O	CXD2560M	Communication line with Digital Filter (Shift Clock; shifted by ↓ and taken in by ↑)
77	D_F_LATCH	O	CXD2560M	Communication line (Latch Pulse) with Digital Filter
78, 79	MODE2, 1	O		Mode Control of the RF amplifier (Not in use)
80	ADRS	O		Not in use

### IC330 Real Time Clock (RP5C62)

The Clock is an IC for clock and calendar and backed up by a lithium battery when the power supply to the set is OFF.

Pin No.	Pin Name	I/O	Description
1	$\overline{CS}$	I	Chip select input. Active "L"
2	CE	I	Chip enable input. Active "H"
3	TMOUT	O	Interval output
4-7	A0-3	I	4 bit address input
8	$\overline{RD}$	I	Read-out control input
9	Vss	—	Power terminal (GND)
10	$\overline{WR}$	I	Write-in control input
11-14	D0-3	I/O	4 bit data input/output
15	$\overline{INTR}$	O	Interrupt output. A 2048Hz signal is output here with the equipment.
16	OSCIN	I	Clock input (32.768kHz)
17	OSCOUT	O	Clock output
18	VDD	—	Power terminal (+5 V)

**IC701 Display Micon (CXP5058H-659Q)**

The Micon controls key input, FL tube display, remote control signal input, level meter (IC702) and EEP-ROM (IC703) according to instructions from the Main Micon (IC312).

Pin No.	Pin Name	I/O	Connected to	Description
1-18	e_-v_SEG	O	FL tube FL701	FL Segment 'e'-'v'
19-28	10_-1_G	O	FL tube FL701	FL Grid #10-#1
29	$\overline{\text{DSP\_REQ}}$	I	MAIN Micon	Communication request ("L" Active)
30	XTAL	—	Ceramic oscillator	
31	EXTAL	I	Ceramic oscillator	4.19MHz ceramic oscillator
32	$\overline{\text{RST}}$	I		System Reset ("L" active)
33	NC	—		Not in use
34	Vdd	I		Power terminal (+5 V)
35-42	AD_0-7	I	Panel switch	Key input A/D converter input #0 - #7
43	NC	—		Not in use
44	DISP_CK	O	MAIN Micon	Shift clock
45	SO	O	MAIN Micon	Serial data OUT
46	SI	I	MAIN Micon	Serial data IN
47	$\overline{\text{DSP\_ACK}}$	O	MAIN Micon	Acknowledge (Active"L")
48	TEST	I	Pull-up	Test mode (Active"L")
49	COUNTER MODE	I	S704	MODE (counter) switch (Active"L")
50	REC MODE	I	S705	REC MODE "H": Standard, "L": Long
51-54	LVL_DT_0-3	I/O	Level Meter IC	Level Meter Data 0-3
55, 56	LVL_ADRS_0, 1	O	Level Meter IC	Level Meter Data 0, 1
57	$\overline{\text{LVL\_RD}}$	O	Level Meter IC	Level Meter Read Mode (Active "L")
58	$\overline{\text{LVL\_WR}}$	O	Level Meter IC	Level Meter Write Mode (Active "L")
59	$\overline{\text{LVL\_SEL}}$	O	Level Meter IC	Level Meter IC Select (Active "L")
60	$\overline{\text{RM\_SEL}}$	O	Open	External remote controller selected (not in use)
61	RMC MON	I	Remote sensor	Remot control signal input
62	RMC	I	Remote sensor	Remot control signal input
63	RMC_CAT	I	Pull-down	Remote control category "L": DAT1, "H": DAT2. Fixed at "L" with the equipment.
64	TR_MUTE	I	IC431	Level meter mute (Active "L")
65	BUSY	I	EEPROM	BUSY signal (Active "L")
66	ROM_DT_IN	I	EEPROM	Data input
67	ROM_DT_OUT	O	EEPROM	Data output
68	$\overline{\text{SHIFT\_CK}}$	O	EEPROM	Shift clock
69	$\overline{\text{CE}}$	O	EEPROM	Chip enable
70	DTC/XPCM	I	Pull-up	Equipment model discrimination input. Fixed at "H" with the equipment
71	Vss	I		Power terminal (GND)
72	TX	—	Open	Not in use
73	NC	—	Open	Not in use
74	TEX	—	+5 V	Not in use
75	Vref	I	+5 V	Analog board reference voltage
76	Vfdp	I	-25 V	FL display tube driving voltage
77-80	a_-d_SEG	O	FL tube	FL Segment 'a'-'d'

## SECTION 5 EXPLODED VIEWS

**NOTE:**

- -XX, -X mean standardized parts, so they may have some differences from the original one.
- Color Indication of Appearance Parts  
Example:  
KNOB,BALANCE(WHITE)...(RED)  
                                  ↑          ↑  
                                  Parts color Cabinet's color

- Items marked "\*\*\*" are not stocked since they are seldom required for routine service. Some delay should be anticipated when ordering these items.
- The mechanical parts with no reference number in the exploded views are not supplied.
- Hardware(# mark) list is given in the last of this parts list.

The components identified by mark  $\Delta$  or dotted line with mark  $\Delta$  are critical for safety.  
Replace only with part number specified.

Les composants identifiés par une marque  $\Delta$  sont critiques pour la sécurité.  
Ne les remplacer que par une pièce portant le numéro spécifié.

### 5-1. CABINET SECTION

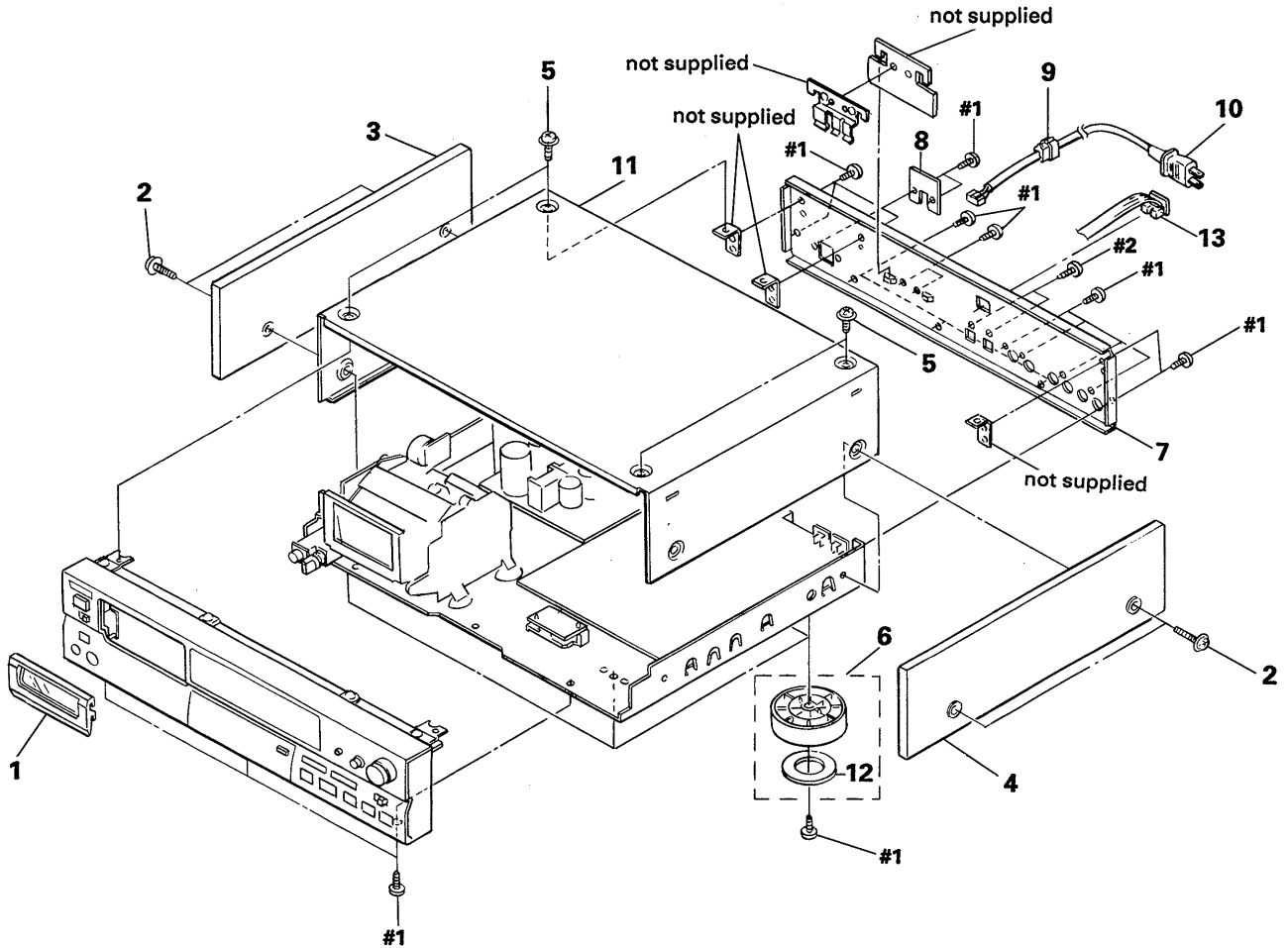

Ref. No.	Part No.	Description	Remarks	Ref. No.	Part No.	Description	Remarks
1	X-3365-595-1	PANEL (CASSETTE) ASSY (AEP:GOLD)		* 7	3-382-125-11	PANEL, BACK (AEP:BLACK)	
1	X-3365-599-1	PANEL (CASSETTE) ASSY (US, Canadian, E/AEP:BLACK)		* 7	3-382-125-21	PANEL, BACK (US, Canadian)	
2	4-933-446-01	SCREW (SIDE PANEL)		* 7	3-382-125-31	PANEL, BACK (E)	
3	X-3365-593-1	PANEL (L) ASSY, SIDE (AEP:GOLD)		* 7	3-382-125-51	PANEL, BACK (AEP:GOLD)	
3	X-3365-634-1	PANEL (L) ASSY, SIDE (AEP:BLACK)		* 8	4-923-873-01	BRACKET, CORD STOPPER	
3	X-3365-636-1	PANEL (L) ASSY, SIDE (US, Canadian, E)		* 9	3-703-244-00	BUSHING (2104), CORD (AEP)	
4	X-3365-594-1	PANEL (R) ASSY, SIDE (AEP:GOLD)		9	4-916-783-01	BUSHING, CORD (US, Canadian, E)	
4	X-3365-635-1	PANEL (R) ASSY, SIDE (AEP:BLACK)		$\Delta$ 10	1-559-297-31	CODE, POWER (E)	
4	X-3365-637-1	PANEL (R) ASSY, SIDE (US, Canadian, E)		$\Delta$ 10	1-559-479-11	CORD, POWER (US, Canadian)	
5	3-704-366-01	SCREW (CASE) (M3X8) (US, Canadian, E/AEP:BLACK)		$\Delta$ 10	1-575-912-11	CORD, POWER (AEP)	
5	3-704-366-11	SCREW (CASE) (M3X8) (AEP:GOLD)		11	4-934-008-01	CASE (US, Canadian, E/AEP:BLACK)	
6	X-3304-938-2	FOOT ASSY (US, Canadian, E/AEP:BLACK)		11	4-934-008-11	CASE (AEP:GOLD)	
6	X-4928-110-1	FOOT ASSY (AEP:GOLD)		12	4-923-836-11	CUSHION	
				13	1-590-321-71	LEAD (WITH CONNECTOR) (CONTROL-S IN) (US, Canadian)	

5-2. FRONT PANEL SECTION

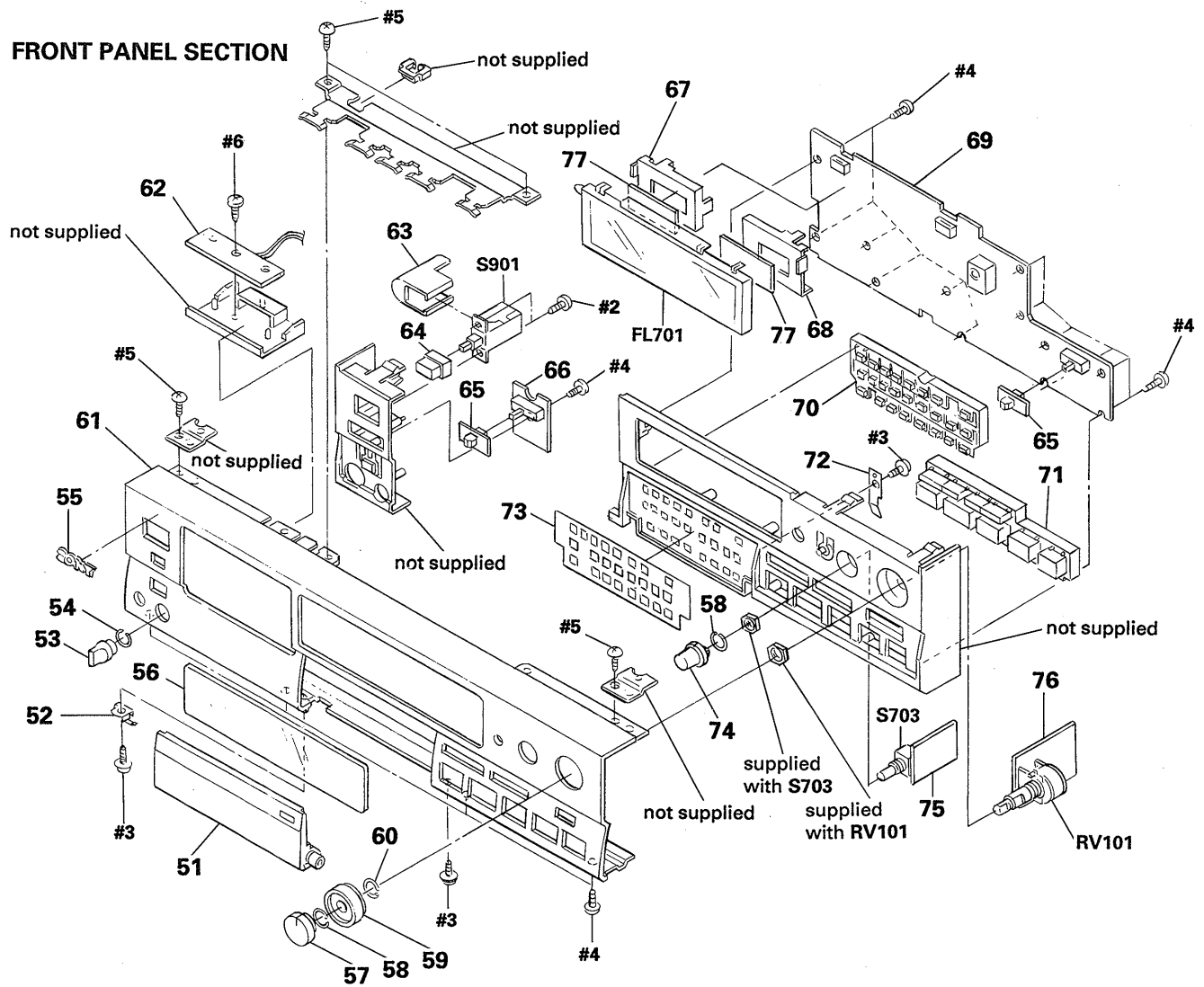

Ref. No.	Part No.	Description	Remarks	Ref. No.	Part No.	Description	Remarks
51	A-2004-110-A	LID ASSY (US, Canadian, E/AEP:BLACK)		64	4-917-460-01	KNOB, POWER (US, Canadian, E/AEP:BLACK)	
51	A-2004-144-A	LID ASSY (AEP:GOLD)		64	4-917-460-51	KNOB, POWER (AEP:GOLD)	
52	3-382-757-01	PLATE (GROUND)		65	3-382-651-01	KNOB (US, Canadian, E/AEP:BLACK)	
53	3-354-931-01	KNOB (DIA. 10) (US, Canadian, E/AEP:BLACK)		65	3-382-651-11	KNOB (AEP:GOLD)	
53	3-354-931-31	KNOB (DIA. 10) (AEP:GOLD)		* 66	1-645-243-11	TIMER SW BOARD	
54	3-354-981-01	SPRING (SUS), RING (US, Canadian, E/AEP:BLACK)		* 67	4-922-524-01	HOLDER (LEFT)	
54	3-356-935-01	SPRING (AEP:GOLD)		* 68	4-922-523-01	HOLDER (RIGHT)	
55	4-908-848-01	EMBLEM, SONY (US, Canadian, E/AEP:BLACK)		* 69	A-2006-811-A	CONTROL SW BOARD, COMPLETE (AEP, E)	
55	4-908-848-21	EMBLEM, SONY (AEP:GOLD)		* 69	A-2006-865-A	CONTROL SW BOARD, COMPLETE (US, Canadian)	
56	3-382-629-01	WINDOW (FL TUBE)		70	3-382-628-01	BUTTON (SUB) (US, Canadian, E/AEP:BLACK)	
56	3-382-629-01	WINDOW (FL TUBE)		70	3-382-628-11	BUTTON (SUB) (AEP:GOLD)	
57	3-382-635-01	KNOB (REC-R) (US, Canadian, E/AEP:BLACK)		71	3-382-644-01	BUTTON (MAIN) (US, Canadian, E/AEP:BLACK)	
57	3-382-635-11	KNOB (REC-R) (AEP:GOLD)		71	3-382-644-11	BUTTON (MAIN) (AEP:GOLD)	
58	3-356-957-01	SPRING		72	3-382-623-01	SPRING, LEAF	
59	3-382-634-01	KNOB (REC-L) (US, Canadian, E/AEP:BLACK)		73	3-382-639-01	SHEET (US, Canadian, E/AEP:BLACK)	
59	3-382-634-11	KNOB (REC-L) (AEP:GOLD)		73	3-382-639-11	SHEET (AEP:GOLD)	
60	3-382-627-01	SPRING, RING		74	3-364-173-11	KNOB (BAL) (US, Canadian, E/AEP:BLACK)	
61	3-382-649-01	PANEL (FRONT) (E/AEP:BLACK)		74	3-364-173-21	KNOB (BAL) (AEP:GOLD)	
61	3-382-649-11	PANEL (FRONT) (AEP:GOLD)		* 75	1-645-240-11	INPUT SW BOARD	
61	3-382-649-21	PANEL (FRONT) (US, Canadian)		* 76	1-645-239-11	REC VOL BOARD	
* 62	1-645-241-11	LED BOARD		77	9-911-839-XX	CUSHION	
63	3-575-524-00	COVER, POWER SWITCH		FL701	1-519-672-21	INDICATOR TUBE, FLUORESCENT	
				△S901	1-554-920-21	SWITCH, PUSH (AC POWER) (1 KEY) (POWER)	

5-3. CHASSIS SECTION

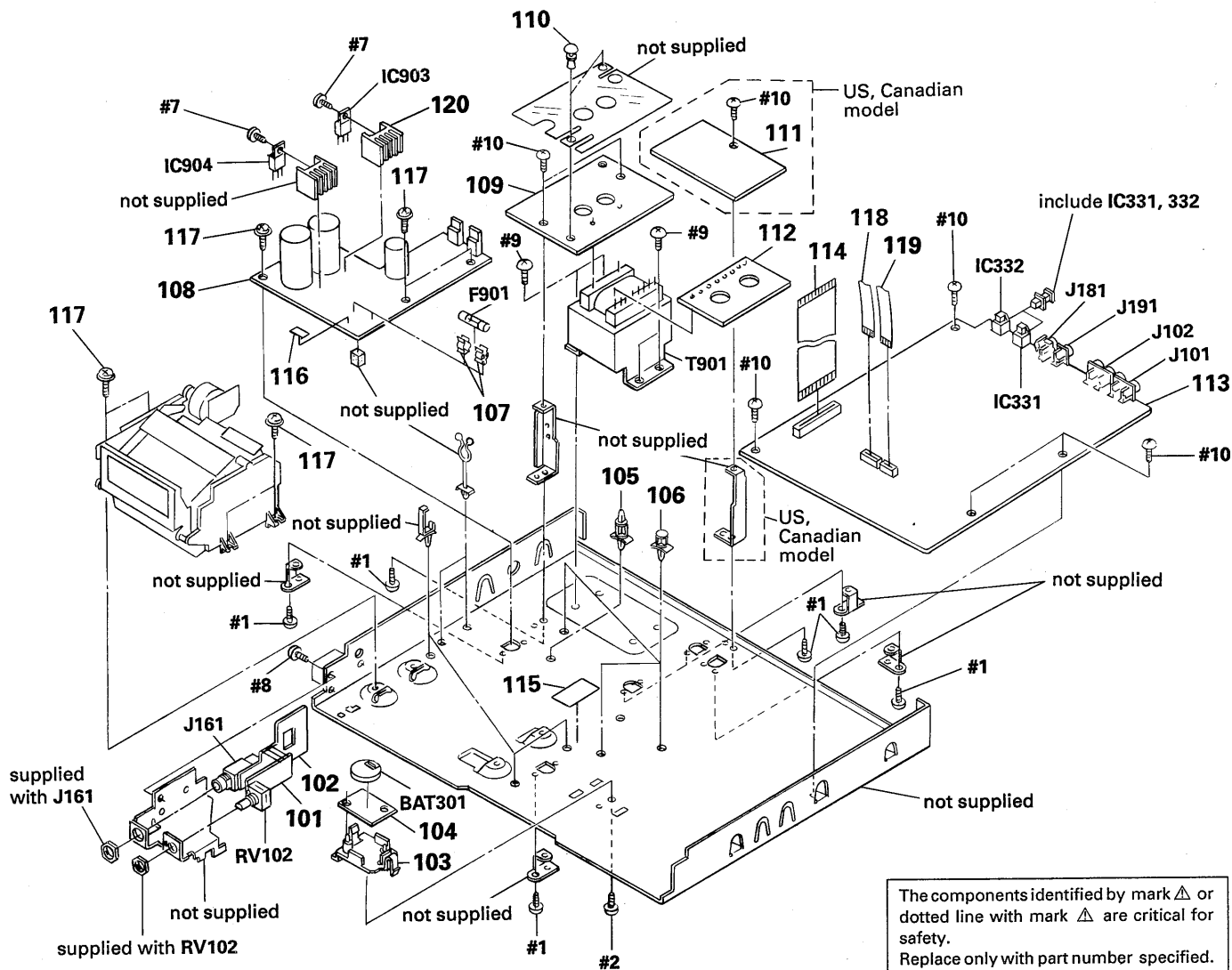

The components identified by mark  $\Delta$  or dotted line with mark  $\Delta$  are critical for safety. Replace only with part number specified.

Les composants identifiés par une marque  $\Delta$  sont critiques pour la sécurité. Ne les remplacer que par une pièce portant le numéro spécifié.

Ref. No.	Part No.	Description	Remarks	Ref. No.	Part No.	Description	Remarks
* 101	1-645-245-11	HEADPHONE VOL BOARD		114	1-590-915-11	WIRE, FLAT TYPE (30 CORE)	
* 102	1-645-244-11	HEADPHONE JACK BOARD		* 115	3-703-044-26	LABEL, CAUTION (US, Canadian)	
* 103	3-382-640-11	HOLDER (BATTERY)		116	3-701-947-15	LABEL (T2.5A), FUSE (AEP, E)	
* 104	1-645-242-11	BATTERY BOARD		117	4-886-821-11	SCREW, S TIGHT, +PTWH 3X6	
* 105	3-346-265-11	HOLDER, PC BOARD		118	1-590-916-11	WIRE, FLAT TYPE (10 CORE)	
* 106	3-670-570-00	SPACER, SUPPORT		119	1-590-914-11	WIRE, FLAT TYPE (6 CORE)	
107	1-533-183-11	HOLDER, FUSE		* 120	4-363-146-71	HEATSINK, V. OUT	
* 108	A-2006-819-A	POWER BOARD, COMPLETE		$\Delta$ BAT301	1-528-229-11	BATTERY, LITHIUMCR-2450	
* 109	1-645-234-11	PRIMARY BOARD		$\Delta$ F901	1-532-744-11	FUSE, GLASS TUBE (2.5A) (US, Canadian)	
110	4-812-134-00	RIVET NYLON, 3.5		$\Delta$ F901	1-532-286-11	FUSE, TIME-LAG (T2.5A) (AEP, E)	
* 111	1-645-237-11	CONTROL (S) BOARD (US, Canadian)		$\Delta$ T901	1-450-556-21	TRANSFORMER, POWER (US, Canadian)	
* 112	1-645-235-11	RELAY BOARD		$\Delta$ T901	1-450-557-21	TRANSFORMER, POWER (AEP)	
* 113	A-2006-863-A	MAIN BOARD, COMPLETE (AEP)		$\Delta$ T901	1-450-558-21	TRANSFORMER, POWER (E)	
* 113	A-2006-866-A	MAIN BOARD, COMPLETE (US, Canadian, E)					

5-4. MECHANISM SECTION 1

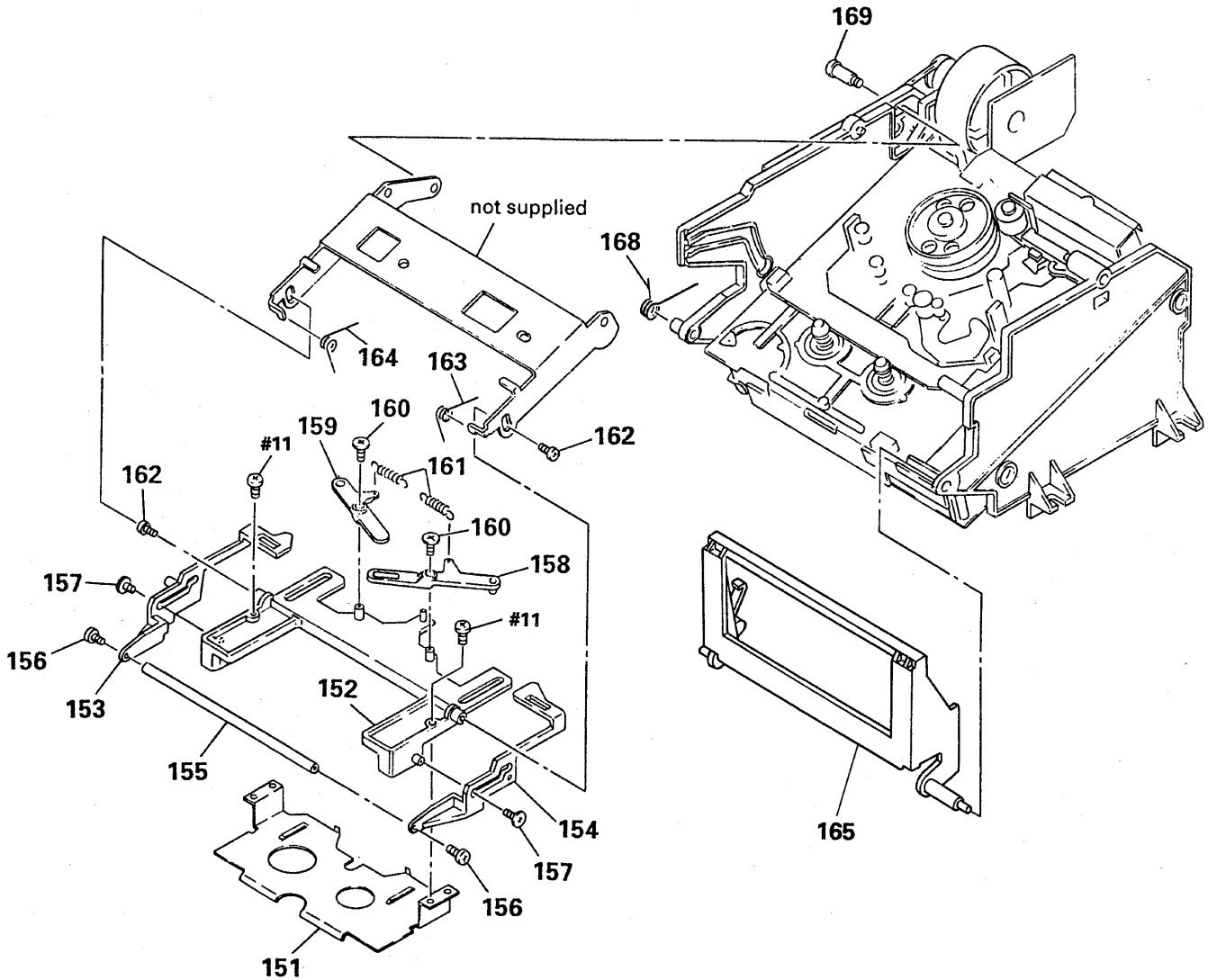

Ref. No.	Part No.	Description	Remarks	Ref. No.	Part No.	Description	Remarks
151	3-373-224-01	HOLDER (LOWER)		160	2-623-756-01	SCREW, (B1.7X3), TAPPING	
152	3-373-237-01	HOLDER (UPPER), CASSETTE		161	3-632-859-00	SPRING, BRAKE LEVER RETURN	
153	3-373-223-01	SLIDER (L)		162	3-318-203-61	SCREW (B1.7X4), TAPPING	
154	3-373-222-01	SLIDER (R)		163	3-373-215-01	SPRING (R), TORSION	
* 155	3-373-217-01	SHAFT (JOINT)		164	3-373-216-01	SPRING (L), TORSION	
156	3-345-648-01	SCREW (M1.4X3.0), TOOTHED LOCK		165	3-382-648-01	HOLDER (WINDOW)	
157	3-318-201-11	SCREW (B) (1.4X3), TAPPING		168	3-373-212-01	SPRING (HOLDER)	
158	3-373-218-01	LEVER (R)		169	4-931-471-01	SCREW (STEP)	
159	3-373-219-01	LEVER (L)					

5-5. MECHANISM SECTION 2

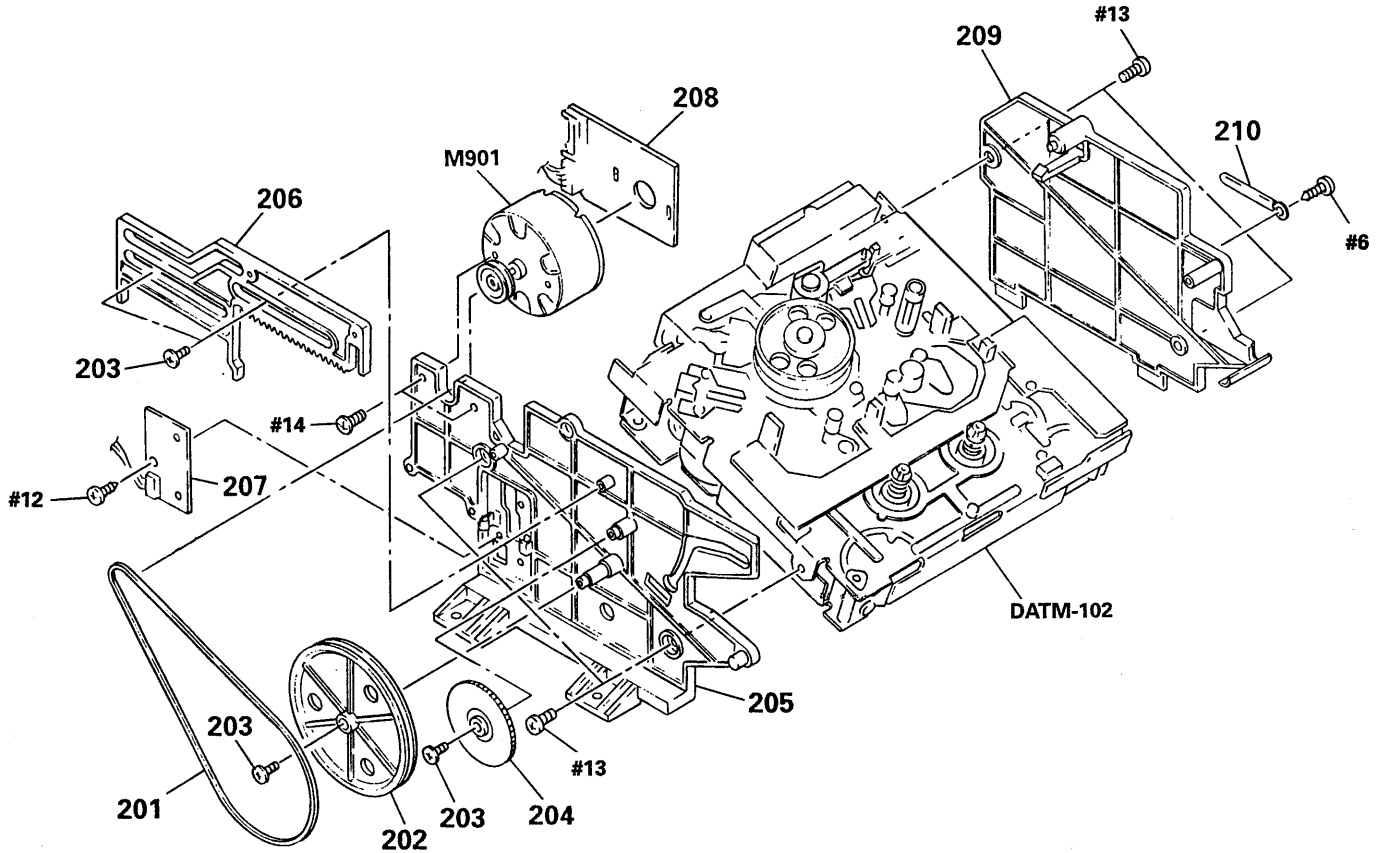

Ref. No.	Part No.	Description	Remarks	Ref. No.	Part No.	Description	Remarks
201	4-931-470-01	BELT (DRIVING)		* 207	1-641-487-11	SW BOARD	
202	3-373-214-01	PULLEY		* 208	1-641-486-11	MOTOR BOARD	
203	2-623-756-01	SCREW, (B1. 7X3), TAPPING		* 209	3-373-235-03	CHASSIS (R)	
204	3-373-213-01	GEAR, DRIVING		210	3-703-150-11	STOPPER, WIRING	
205	3-373-234-04	CHASSIS (L)		M901	A-2003-910-A	MOTOR ASSY, CASSETTE	
206	3-373-221-01	SLIDER (RACK)				(CASSETTE COMPARTMENT)	



5-6. MECHANISM SECTION 3  
(DATM-102)

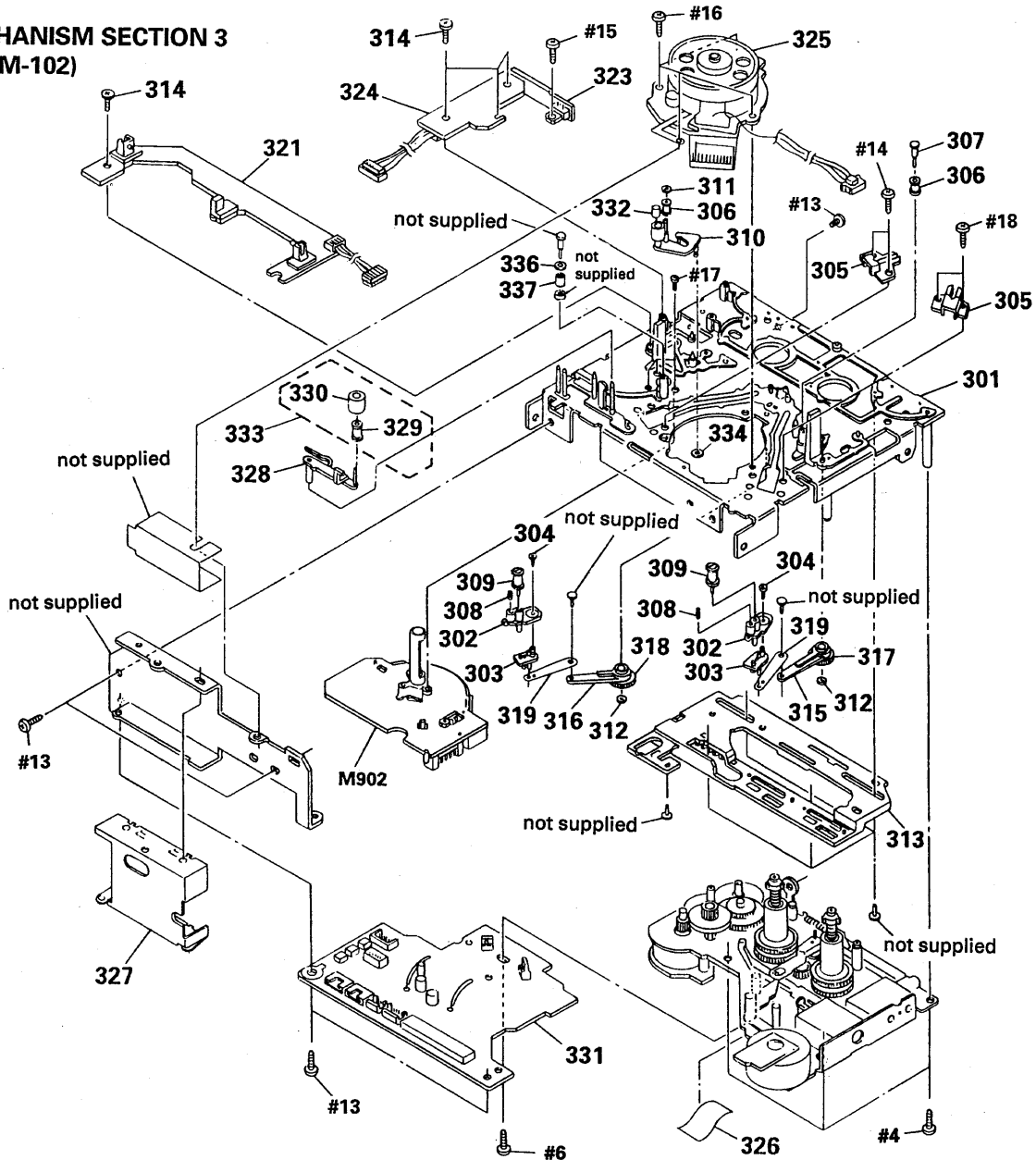

Ref. No.	Part No.	Description	Remarks	Ref. No.	Part No.	Description	Remarks
* 301	3-368-462-01	CHASSIS (OUTSERT), MECHANICAL		319	3-368-415-01	SHAFT (LOAD LEVER JOINT)	
* 302	3-368-390-01	BASE (#1 GUIDE)		* 321	1-639-305-11	TOP END SENSOR BOARD	
303	3-368-409-01	JOINT (#1 GUIDE)		* 323	1-639-301-11	RGN SW BOARD	
304	3-368-413-01	SCREW, +P (1) B1. 4X2.5		* 324	1-639-306-11	CAM SLIDER BOARD	
* 305	3-368-442-01	CATCHER		325	8-848-567-11	DRUM ASSY DOU-03A	
306	3-368-399-01	GUIDE, ROLLER		326	9-911-835-XX	SPACER	
307	3-368-428-01	SHAFT (ROLLER GUIDE)		* 327	A-2001-587-A	RF COMPLETE ASSY	
308	3-368-436-01	SPRING (#1 GUIDE), COMPRESSION		328	3-368-459-01	LEVER (CLEANER)	
309	X-3337-643-1	GUIDE (RIC) ASSY, ROLLER		329	3-353-812-01	COLLAR (ROLLER)	
310	X-3363-025-1	PINCH (LEVER) ASSY		330	3-352-518-01	ROLLER (CLEANER)	
311	3-315-384-31	WASHER, STOPPER		* 331	A-2056-488-A	DRUM DRIVE BOARD, COMPLETE	
312	3-368-398-01	BUSHING		332	3-337-626-01	CAP, PINCH ROLLER	
* 313	A-2003-708-A	SLIDER ASSY, CAM		333	X-3337-655-1	ROLLER (CLEANER) ASSY	
314	3-372-761-01	SCREW (M1. 7X4), TAPPING		334	3-321-813-01	WASHER, COTTER POLYETHYLENE	
315	3-368-427-01	LEVER (LOAD-T)		336	3-337-677-01	FLANGE	
316	3-368-426-01	LEVER (LOAD-S)		337	3-337-676-01	GUIDE, FIXED	
317	3-368-444-01	GEAR (LOAD-T)		M902	8-835-361-01	MOTOR, DC U-17B (CAPSTAN)	
318	3-368-443-01	GEAR (LOAD-S)					

5-7. MECHANISM SECTION 4  
(DATM-102)

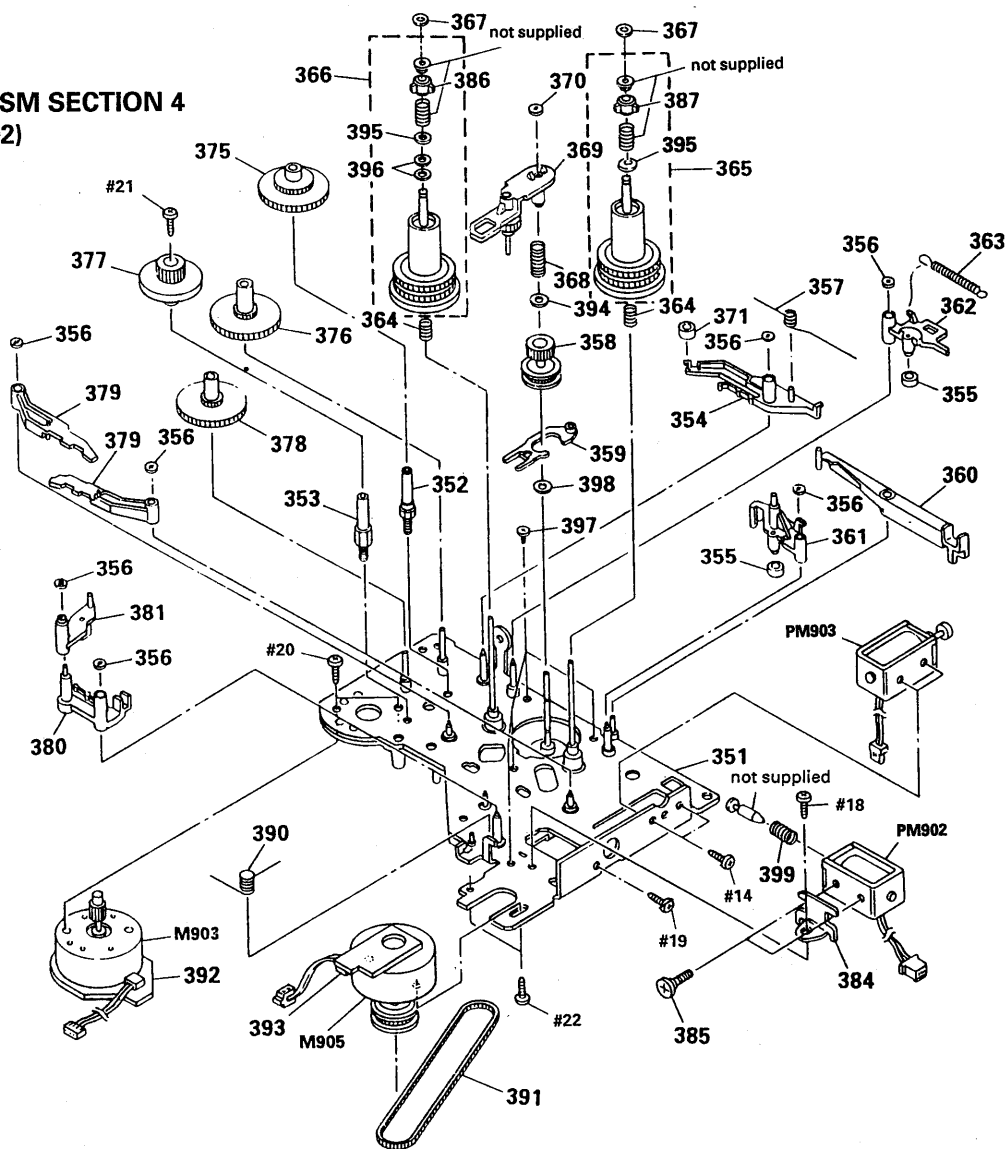

Ref. No.	Part No.	Description	Remarks	Ref. No.	Part No.	Description	Remarks
* 351	A-2003-857-A	CHASSIS (REEL) ASSY		377	3-368-403-01	GEAR (CAM DRIVE D)	
* 352	3-368-420-01	SHAFT (CAM DRIVE GEAR C)		378	3-368-402-01	GEAR (CAM DRIVE A, B)	
* 353	3-368-419-01	SHAFT (CAM DRIVE GEAR D)		379	X-3363-024-1	LEVER (BT) ASSY	
* 354	3-368-455-01	LEVER (GEAR LOCK)		* 380	3-368-451-01	LEVER (BT SOLENOID)	
355	3-368-418-01	TUBE (BREAK)		* 381	3-368-454-01	LEVER (BT SELECTION)	
356	3-368-398-01	BUSHING		* 384	3-368-416-01	BRACKET (B. T SOLENOID)	
357	3-368-430-01	SPRING (GEAR LOCK)		385	3-368-423-01	SCREW (M2.6), STEP	
358	X-3363-022-1	GEAR (REEL DRIVE) ASSY		386	2-623-736-01	CLAW (C) (LEFT), REEL	
* 359	3-368-411-01	SLIDER (REEL LOCK)		387	2-623-752-01	CLAW (C) (RIGHT), REEL	
* 360	3-368-453-01	LEVER (BRAKE SOLENOID)		390	3-368-431-01	SPRING (B. T SOLENOID)	
* 361	3-368-447-01	LEVER (BRAKE S)		391	3-368-417-01	BELT (170TN10-1.0T), TIMING	
* 362	3-368-446-01	LEVER (BRAKE T)		* 392	1-639-303-11	CAM MOTOR BOARD	
363	3-368-438-01	SPRING (BREAK), TENSION		* 393	1-639-304-11	REEL MOTOR BOARD	
364	3-368-432-01	SPRING (FF/REW), COMPRESSION		394	3-738-212-21	RETAINER, THRUST REEL TABLE	
365	A-2003-709-A	TABLE (S) ASSY, REEL		395	3-701-443-11	WASHER	
366	A-2003-710-B	TABLE (T) ASSY, REEL		396	3-701-443-21	WASHER, 5 DIA.	
367	3-578-224-00	WASHER		397	2-623-756-01	SCREW, (B1.7X3), TAPPING	
368	3-368-435-01	SPRING (FR LEVER), COMPRESSION		398	3-701-436-01	WASHER, 1.6	
369	X-3364-581-1	LEVER (F/R) ASSY		399	3-370-480-01	SPRING (BT), COMPRESSION	
370	3-315-384-31	WASHER, STOPPER		M903	X-3363-109-1	MOTOR (CAM) ASSY	
371	3-377-332-01	TUBE (BREAK2)		M905	X-3363-110-1	MOTOR (REEL) ASSY	
375	3-368-421-01	GEAR (CAM DRIVE C)		PM902	1-454-536-11	SOLENOID, PLUNGER (BT CONTROL)	
376	3-373-039-01	GEAR (CAM DRIVE B)		PM903	1-454-535-11	SOLENOID, PLUNGER (BRAKE)	

## SECTION 6 ELECTRICAL PARTS LIST

**NOTE:**

The components identified by mark  $\Delta$  or dotted line with mark  $\Delta$  are critical for safety.  
Replace only with part number specified.

Les composants identifiés par une marque  $\Delta$  sont critiques pour la sécurité.  
Ne les remplacer que par une pièce portant le numéro spécifié.

When indicating parts by reference number, please include the board name.

- Due to standardization, replacements in the parts list may be different from the parts specified in the diagrams or the components used on the set.
- -XX, -X mean standardized parts, so they may have some difference from the original one.
- RESISTORS  
All resistors are in ohms  
METAL : Metal-film resistor  
METAL OXIDE : Metal Oxide-film resistor  
F : nonflammable
- Items marked "\*\*\*" are not stocked since they are seldom required for routine service. Some delay should be anticipated when ordering these items.
- SEMICONDUCTORS  
In each case, u :  $\mu$ , for example :  
uA...:  $\mu$ A..., uPA...:  $\mu$ PA...,  
uPB...:  $\mu$ PB..., uPC...:  $\mu$ PC...,  
uPD...:  $\mu$ PD...
- CAPACITORS  
uF :  $\mu$ F  
uH :  $\mu$ H

<b>BATTERY</b>	<b>CAM MOTOR</b>	<b>CAM SLIDER</b>	<b>CONTROL (S)</b>	<b>CONTROL SW</b>
----------------	------------------	-------------------	--------------------	-------------------

Ref. No.	Part No.	Description	Remarks	Ref. No.	Part No.	Description	Remarks
*	1-645-242-11	BATTERY BOARD ***** < BATTERY >				< CONNECTOR >	
$\Delta$ BAT301	1-528-229-11	BATTERY, LITHIUM (CR-2450) < CONNECTOR >		CN801	1-558-350-21	CORD (WITH CONNECTOR) (US, Canadian)	
*	CN371	1-564-337-00 PIN, CONNECTOR 3P (US, Canadian)		* CN831	1-564-705-11	PIN, CONNECTOR (SMALL TYPE) 3P (US, Canadian)	
*	CN381	1-564-705-11 PIN, CONNECTOR (SMALL TYPE) 3P (US, Canadian) *****				< DIODE >	
*	1-639-303-11	CAM MOTOR BOARD ***** < CAPACITOR >		D801	8-719-107-94	DIODE 1SS202-1 (US, Canadian)	
	C06	1-163-077-00 CERAMIC CHIP 0.1uF 10% 25V *****		D802	8-719-107-94	DIODE 1SS202-1 (US, Canadian)	
*	1-639-306-11	CAM SLIDER BOARD ***** < JUMPER RESISTOR >				< RESISTOR >	
	JW04	1-216-296-00 METAL CHIP 0 5% 1/8W		R801	1-249-393-11	CARBON 10 5% 1/4W (US, Canadian)	
	JW05	1-216-296-00 METAL CHIP 0 5% 1/8W < SWITCH >		R802	1-249-429-11	CARBON 10K 5% 1/4W (US, Canadian)	
	SW1	1-570-953-11 SWITCH, PUSH (1 KEY) (STOP DET)		R803	1-249-429-11	CARBON 10K 5% 1/4W (US, Canadian)	
	SW2	1-570-953-11 SWITCH, PUSH (1 KEY) (FWD DET) *****		R804	1-249-405-11	CARBON 100 5% 1/4W (US, Canadian)	
*	1-645-237-11	CONTROL (S) BOARD (US, Canadian) *****		R805	1-249-429-11	CARBON 10K 5% 1/4W (US, Canadian)	
	4-870-539-00	PLATE, GROUND (US, Canadian) < CAPACITOR >		R806	1-249-429-11	CARBON 10K 5% 1/4W (US, Canadian) *****	
	C801	1-164-159-11 CERAMIC 0.1uF 50V (US, Canadian)		*	A-2006-865-A	CONTROL SW BOARD, COMPLETE (US, Canadian)	
	C802	1-164-159-11 CERAMIC 0.1uF 50V (US, Canadian)		*	A-2006-811-A	CONTROL SW BOARD, COMPLETE (AEP, E) *****	
						< CAPACITOR >	
				C701	1-161-379-00	CERAMIC 0.01uF 20% 25V	
				C702	1-161-379-00	CERAMIC 0.01uF 20% 25V	
				C703	1-124-584-00	ELECT 100uF 20% 10V	
				C704	1-161-379-00	CERAMIC 0.01uF 20% 25V	
				C705	1-161-379-00	CERAMIC 0.01uF 20% 25V	
				C706	1-161-379-00	CERAMIC 0.01uF 20% 25V	
						< CONNECTOR >	
				CN751	1-568-853-11	SOCKET, CONNECTOR 10P	
				CN752	1-568-849-11	SOCKET, CONNECTOR 6P	
				* CN771	1-564-337-00	PIN, CONNECTOR 3P	
						< COMPOSITION CIRCUIT BLOCK >	
				CP701	1-233-140-11	COMPOSITION CIRCUIT BLOCK (100k X 8)	
				CP702	1-233-140-11	COMPOSITION CIRCUIT BLOCK (100k X 8)	

## CONTROL SW

Ref. No.	Part No.	Description	Remarks	Ref. No.	Part No.	Description	Remarks
CP703	1-233-140-11	COMPOSITION CIRCUIT BLOCK (100k X 8)		R736	1-249-424-11	CARBON	3.9K 5% 1/4W
CP704	1-233-140-11	COMPOSITION CIRCUIT BLOCK (100k X 8)		R737	1-249-427-11	CARBON	6.8K 5% 1/4W
		< FLUORESCENT INDICATOR >		R738	1-249-432-11	CARBON	18K 5% 1/4W
FL701	1-519-672-21	INDICATOR TUBE, FLUORESCENT		R739	1-249-429-11	CARBON	10K 5% 1/4W
		< IC >		R740	1-249-422-11	CARBON	2.7K 5% 1/4W
IC701	8-752-837-19	IC CXP5058H-659Q		R741	1-249-424-11	CARBON	3.9K 5% 1/4W
IC702	8-759-995-09	IC MSM6338RS		R742	1-249-427-11	CARBON	6.8K 5% 1/4W
IC703	8-752-330-59	IC CXK1011P		R743	1-249-432-11	CARBON	18K 5% 1/4W
IC704	8-749-922-36	IC GPIU50XB		R744	1-249-437-11	CARBON	47K 5% 1/4W
IC705	8-759-140-11	IC uPD4011BC (US, Canadian)		R745	1-249-437-11	CARBON	47K 5% 1/4W
		< TRANSISTOR >		R746	1-249-437-11	CARBON	47K 5% 1/4W
Q701	8-729-902-11	TRANSISTOR 2SC2021-Q		R747	1-249-437-11	CARBON	47K 5% 1/4W
Q702	8-729-902-11	TRANSISTOR 2SC2021-Q		R748	1-249-437-11	CARBON	47K 5% 1/4W
Q703	8-729-902-11	TRANSISTOR 2SC2021-Q		R749	1-249-437-11	CARBON	47K 5% 1/4W
		< RESISTOR >		R750	1-249-437-11	CARBON	47K 5% 1/4W
R701	1-249-441-11	CARBON	100K 5% 1/4W	R751	1-249-437-11	CARBON	47K 5% 1/4W
R702	1-249-441-11	CARBON	100K 5% 1/4W	R752	1-249-437-11	CARBON	47K 5% 1/4W
R703	1-249-441-11	CARBON	100K 5% 1/4W	R753	1-249-437-11	CARBON	47K 5% 1/4W
R708	1-249-429-11	CARBON	10K 5% 1/4W	R754	1-249-437-11	CARBON	47K 5% 1/4W
R709	1-249-422-11	CARBON	2.7K 5% 1/4W	R755	1-249-437-11	CARBON	47K 5% 1/4W
R710	1-249-424-11	CARBON	3.9K 5% 1/4W	R756	1-249-437-11	CARBON	47K 5% 1/4W (AEP, E)
R711	1-249-427-11	CARBON	6.8K 5% 1/4W	R757	1-249-437-11	CARBON	47K 5% 1/4W (US, Canadian)
R712	1-249-432-11	CARBON	18K 5% 1/4W	R758	1-249-409-11	CARBON	220 5% 1/4W
R713	1-249-429-11	CARBON	10K 5% 1/4W				
R714	1-249-422-11	CARBON	2.7K 5% 1/4W				
R715	1-249-424-11	CARBON	3.9K 5% 1/4W				
R716	1-249-429-11	CARBON	10K 5% 1/4W				
R717	1-249-422-11	CARBON	2.7K 5% 1/4W				
R718	1-249-424-11	CARBON	3.9K 5% 1/4W				
R719	1-249-427-11	CARBON	6.8K 5% 1/4W				
R720	1-249-432-11	CARBON	18K 5% 1/4W				
R721	1-249-429-11	CARBON	10K 5% 1/4W				
R722	1-249-422-11	CARBON	2.7K 5% 1/4W				
R723	1-249-424-11	CARBON	3.9K 5% 1/4W				
R724	1-249-427-11	CARBON	6.8K 5% 1/4W				
R725	1-249-432-11	CARBON	18K 5% 1/4W				
R726	1-249-429-11	CARBON	10K 5% 1/4W				
R727	1-249-422-11	CARBON	2.7K 5% 1/4W				
R728	1-249-424-11	CARBON	3.9K 5% 1/4W				
R729	1-249-427-11	CARBON	6.8K 5% 1/4W				
R730	1-249-432-11	CARBON	18K 5% 1/4W				
R731	1-249-429-11	CARBON	10K 5% 1/4W				
R732	1-249-422-11	CARBON	2.7K 5% 1/4W				
R733	1-249-424-11	CARBON	3.9K 5% 1/4W				
R734	1-249-429-11	CARBON	10K 5% 1/4W				
R735	1-249-422-11	CARBON	2.7K 5% 1/4W				
		< SWITCH >		S704	1-554-937-11	SWITCH, KEY BOARD (MODE)	
				S705	1-570-974-11	SWITCH, SLIDE (REC MODE)	
				S706	1-554-937-11	SWITCH, KEY BOARD (1)	
				S707	1-554-937-11	SWITCH, KEY BOARD (2)	
				S708	1-554-937-11	SWITCH, KEY BOARD (3)	
				S709	1-554-937-11	SWITCH, KEY BOARD (4)	
				S710	1-554-937-11	SWITCH, KEY BOARD (5)	
				S711	1-554-937-11	SWITCH, KEY BOARD (6)	
				S712	1-554-937-11	SWITCH, KEY BOARD (7)	
				S713	1-554-937-11	SWITCH, KEY BOARD (8)	
				S714	1-554-937-11	SWITCH, KEY BOARD (9)	
				S715	1-554-937-11	SWITCH, KEY BOARD (0)	
				S716	1-554-937-11	SWITCH, KEY BOARD (FADER)	
				S717	1-554-937-11	SWITCH, KEY BOARD (MUSIC SCAN)	
				S718	1-554-937-11	SWITCH, KEY BOARD (MARGIN RESET)	
				S719	1-554-937-11	SWITCH, KEY BOARD (CLEAR)	
				S720	1-554-937-11	SWITCH, KEY BOARD (DATE RECORDED)	
				S721	1-554-937-11	SWITCH, KEY BOARD (DATE PRESENT)	
				S722	1-554-937-11	SWITCH, KEY BOARD (DATE CLOCK SET)	
				S723	1-554-937-11	SWITCH, KEY BOARD (AUTO)	
				S724	1-554-937-11	SWITCH, KEY BOARD (RENUMBER)	
				S725	1-554-937-11	SWITCH, KEY BOARD (WRITE START ID)	
				S726	1-554-937-11	SWITCH, KEY BOARD (WRITE SKIP ID)	
				S727	1-554-937-11	SWITCH, KEY BOARD (WRITE END ID)	
				S728	1-554-937-11	SWITCH, KEY BOARD (ERASE START ID)	

When indicating parts by reference number, please include the board name.

**CONTROL SW      DRUM DRIVE**

Ref. No.	Part No.	Description	Remarks
S729	1-554-937-11	SWITCH, KEY BOARD (ERASE SKIP ID)	
S730	1-554-937-11	SWITCH, KEY BOARD (ERASE END ID)	
S731	1-554-937-11	SWITCH, KEY BOARD ( ■ )	
S732	1-554-937-11	SWITCH, KEY BOARD ( ► )	
S733	1-554-937-11	SWITCH, KEY BOARD (AMS □◀◀ )	
S734	1-554-937-11	SWITCH, KEY BOARD (AMS ▷▷□ )	
S735	1-554-937-11	SWITCH, KEY BOARD ( ◀◀ )	
S736	1-554-937-11	SWITCH, KEY BOARD ( ►► )	
S737	1-554-937-11	SWITCH, KEY BOARD ( ● REC)	
S738	1-554-937-11	SWITCH, KEY BOARD ( ■ PAUSE)	
S739	1-554-937-11	SWITCH, KEY BOARD ( ○ REC MUTE)	
< VIBRATOR >			
X701	1-577-359-21	VIBRATOR, CERAMIC (4.19MHz)	
*****			
*	A-2056-488-A	DRUM DRIVE BOARD, COMPLETE	
*****			
*	3-343-491-01	HOLDER (S SENSOR B)	
	4-870-539-00	PLATE, GROUND	
< CAPACITOR >			
C01	1-126-176-11	ELECT      220uF      20%      10V	
C02	1-126-157-11	ELECT      10uF      20%      16V	
C03	1-124-257-00	ELECT      2. 2uF      20%      50V	
C04	1-164-161-11	CERAMIC CHIP      0. 0022uF      10%      100V	
C05	1-164-161-11	CERAMIC CHIP      0. 0022uF      10%      100V	
C08	1-163-001-11	CERAMIC CHIP      220PF      10%      50V	
C21	1-163-001-11	CERAMIC CHIP      220PF      10%      50V	
C31	1-163-001-11	CERAMIC CHIP      220PF      10%      50V	
< CONNECTOR >			
* CN01	1-564-704-11	PIN, CONNECTOR (SMALL TYPE) 2P	
* CN02	1-564-704-11	PIN, CONNECTOR (SMALL TYPE) 2P	
* CN03	1-564-338-00	PIN, CONNECTOR 4P	
* CN04	1-564-336-00	PIN, CONNECTOR 2P	
* CN05	1-564-336-61	PIN, CONNECTOR 2P	
* CN06	1-564-339-00	PIN, CONNECTOR 5P	
CN07	1-564-721-11	PIN, CONNECTOR (SMALL TYPE) 5P	
* CN08	1-568-872-11	SOCKET, CONNECTOR 30P	
* CN09	1-564-706-11	PIN, CONNECTOR (SMALL TYPE) 4P	
* CN10	1-564-719-11	PIN, CONNECTOR (SMALL TYPE) 3P	
< IC >			
IC01	8-759-107-68	IC      CX20115A	
IC02	8-759-502-80	IC      LM358M	
IC03	8-759-502-80	IC      LM358M	
< JUMPER RESISTOR >			
JW06	1-216-296-00	METAL CHIP      0      5%      1/8W	

Ref. No.	Part No.	Description	Remarks
JW07	1-216-296-00	METAL CHIP      0      5%      1/8W	
JW08	1-216-296-00	METAL CHIP      0      5%      1/8W	
JW09	1-216-296-00	METAL CHIP      0      5%      1/8W	
JW10	1-216-296-00	METAL CHIP      0      5%      1/8W	
JW11	1-216-296-00	METAL CHIP      0      5%      1/8W	
JW12	1-216-296-00	METAL CHIP      0      5%      1/8W	
JW13	1-216-296-00	METAL CHIP      0      5%      1/8W	
JW14	1-216-296-00	METAL CHIP      0      5%      1/8W	
JW15	1-216-296-00	METAL CHIP      0      5%      1/8W	
JW16	1-216-296-00	METAL CHIP      0      5%      1/8W	
JW17	1-216-296-00	METAL CHIP      0      5%      1/8W	
JW18	1-216-296-00	METAL CHIP      0      5%      1/8W	
JW19	1-216-296-00	METAL CHIP      0      5%      1/8W	
JW20	1-216-296-00	METAL CHIP      0      5%      1/8W	
JW21	1-216-296-00	METAL CHIP      0      5%      1/8W	
JW22	1-216-296-00	METAL CHIP      0      5%      1/8W	
JW23	1-216-296-00	METAL CHIP      0      5%      1/8W	
JW24	1-216-296-00	METAL CHIP      0      5%      1/8W	
JW25	1-216-296-00	METAL CHIP      0      5%      1/8W	
JW26	1-216-296-00	METAL CHIP      0      5%      1/8W	
JW27	1-216-296-00	METAL CHIP      0      5%      1/8W	
JW28	1-216-296-00	METAL CHIP      0      5%      1/8W	
JW29	1-216-296-00	METAL CHIP      0      5%      1/8W	
JW30	1-216-296-00	METAL CHIP      0      5%      1/8W	
< PHOTO INTERRUPTER >			
PH01	8-719-939-23	DIODE      GP2S09-C	
PH02	8-719-939-23	DIODE      GP2S09-C	
< TRANSISTOR >			
Q01	8-729-120-28	TRANSISTOR      2SC1623-L5L6	
Q02	8-729-101-07	TRANSISTOR      2SB798-DL	
< RESISTOR >			
R01	1-216-061-00	METAL CHIP      3. 3K      5%      1/10W	
R02	1-216-075-00	METAL CHIP      12K      5%      1/10W	
R03	1-216-029-00	METAL CHIP      150      5%      1/10W	
R04	1-216-059-00	METAL CHIP      2. 7K      5%      1/10W	
R05	1-216-057-00	METAL CHIP      2. 2K      5%      1/10W	
R06	1-216-085-00	METAL CHIP      33K      5%      1/10W	
R07	1-216-025-00	METAL CHIP      100      5%      1/10W	
R08	1-216-049-00	METAL CHIP      1K      5%      1/10W	
R09	1-216-073-00	METAL CHIP      10K      5%      1/10W	
R10	1-216-073-00	METAL CHIP      10K      5%      1/10W	
R11	1-216-073-00	METAL CHIP      10K      5%      1/10W	
R12	1-216-089-00	METAL CHIP      47K      5%      1/10W	
R13	1-216-073-00	METAL CHIP      10K      5%      1/10W	
R14	1-216-037-00	METAL CHIP      330      5%      1/10W	
R21	1-216-073-00	METAL CHIP      10K      5%      1/10W	
R22	1-216-081-00	METAL CHIP      22K      5%      1/10W	

When indicating parts by reference number, please include the board name.



## MAIN

Ref.No.	Part No.	Description	Remarks			Ref.No.	Part No.	Description	Remarks		
C218	1-130-478-00	MYLAR	0.0039uF	5%	50V	C348	1-126-059-11	ELECT	10uF	20%	63V
C220	1-126-023-11	ELECT	100uF	20%	25V	C362	1-126-043-11	ELECT	0.47uF	20%	50V
C300	1-162-294-31	CERAMIC	0.001uF	10%	50V	C363	1-126-059-11	ELECT	10uF	20%	63V
C301	1-130-834-00	FILM	1uF	10%	63V	C401	1-136-165-00	FILM	0.1uF	5%	50V
C302	1-164-159-11	CERAMIC	0.1uF		50V	C402	1-136-165-00	FILM	0.1uF	5%	50V
C303	1-162-211-31	CERAMIC	33PF	5%	50V	C405	1-136-165-00	FILM	0.1uF	5%	50V
C304	1-126-059-11	ELECT	10uF	20%	63V	C406	1-126-059-11	ELECT	10uF	20%	63V
C305	1-136-153-00	FILM	0.01uF	5%	50V	C407	1-136-165-00	FILM	0.1uF	5%	50V
C306	1-164-159-11	CERAMIC	0.1uF		50V	C408	1-136-165-00	FILM	0.1uF	5%	50V
C307	1-126-022-11	ELECT	47uF	20%	10V	C409	1-126-104-11	ELECT	470uF	20%	35V
C308	1-164-159-11	CERAMIC	0.1uF		50V	C410	1-136-165-00	FILM	0.1uF	5%	50V
C309	1-124-983-11	ELECT	330uF	20%	6.3V	C411	1-126-104-11	ELECT	470uF	20%	35V
C310	1-130-834-00	FILM	1uF	10%	63V	C412	1-136-165-00	FILM	0.1uF	5%	50V
C311	1-162-279-31	CERAMIC	75PF	10%	50V	C413	1-126-104-11	ELECT	470uF	20%	35V
C312	1-126-022-11	ELECT	47uF	20%	10V	C414	1-126-104-11	ELECT	470uF	20%	35V
C313	1-126-023-11	ELECT	100uF	20%	25V	C415	1-164-159-11	CERAMIC	0.1uF		50V
C314	1-162-199-31	CERAMIC	10PF	5%	50V	C417	1-164-159-11	CERAMIC	0.1uF		50V
C315	1-162-294-31	CERAMIC	0.001uF	10%	50V	C426	1-136-165-00	FILM	0.1uF	5%	50V
C316	1-162-199-31	CERAMIC	10PF	5%	50V	C427	1-136-165-00	FILM	0.1uF	5%	50V
C317	1-162-201-31	CERAMIC	12PF	5%	50V	C428	1-136-165-00	FILM	0.1uF	5%	50V
C318	1-162-201-31	CERAMIC	12PF	5%	50V	C429	1-136-165-00	FILM	0.1uF	5%	50V
C319	1-164-159-11	CERAMIC	0.1uF		50V	C430	1-126-059-11	ELECT	10uF	20%	63V
C320	1-130-834-00	FILM	1uF	10%	63V	C431	1-126-059-11	ELECT	10uF	20%	63V
C321	1-136-165-00	FILM	0.1uF	5%	50V	C432	1-124-273-00	ELECT	3.3uF	20%	50V
C322	1-164-159-11	CERAMIC	0.1uF		50V	C438	1-124-983-11	ELECT	330uF	20%	6.3V
C323	1-162-206-31	CERAMIC	20PF	5%	50V	C439	1-164-159-11	CERAMIC	0.1uF		50V
C324	1-164-159-11	CERAMIC	0.1uF		50V	C440	1-126-916-11	ELECT	1000uF	20%	6.3V
C325	1-126-022-11	ELECT	47uF	20%	10V	C441	1-164-159-11	CERAMIC	0.1uF		50V
C326	1-162-201-31	CERAMIC	12PF	5%	50V	C442	1-164-159-11	CERAMIC	0.1uF		50V
C327	1-162-201-31	CERAMIC	12PF	5%	50V	C444	1-164-159-11	CERAMIC	0.1uF		50V
C328	1-124-903-11	ELECT	1uF	20%	50V	C445	1-164-159-11	CERAMIC	0.1uF		50V
C329	1-162-294-31	CERAMIC	0.001uF	10%	50V	C446	1-164-159-11	CERAMIC	0.1uF		50V
C330	1-162-294-31	CERAMIC	0.001uF	10%	50V	C447	1-164-159-11	CERAMIC	0.1uF		50V
C331	1-162-294-31	CERAMIC	0.001uF	10%	50V	C448	1-164-159-11	CERAMIC	0.1uF		50V
C332	1-162-293-31	CERAMIC	820PF	10%	50V	C449	1-164-159-11	CERAMIC	0.1uF		50V
C333	1-162-283-31	CERAMIC	120PF	10%	50V	C450	1-136-165-00	FILM	0.1uF	5%	50V
C334	1-161-375-00	CERAMIC	0.0022uF	20%	50V	C451	1-136-165-00	FILM	0.1uF	5%	50V
C335	1-161-375-00	CERAMIC	0.0022uF	20%	50V	C460	1-164-159-11	CERAMIC	0.1uF		50V
C336	1-162-289-31	CERAMIC	390PF	10%	50V	C461	1-164-159-11	CERAMIC	0.1uF		50V
C337	1-161-329-00	CERAMIC	0.0068uF	30%	16V	C462	1-164-159-11	CERAMIC	0.1uF		50V
C338	1-162-306-11	CERAMIC	0.01uF	20%	16V	C470	1-164-159-11	CERAMIC	0.1uF		50V
C339	1-162-306-11	CERAMIC	0.01uF	20%	16V	C471	1-164-159-11	CERAMIC	0.1uF		50V
C340	1-162-290-31	CERAMIC	470PF	10%	50V	C472	1-164-159-11	CERAMIC	0.1uF		50V
C341	1-162-306-11	CERAMIC	0.01uF	20%	16V	C473	1-164-159-11	CERAMIC	0.1uF		50V
C342	1-126-059-11	ELECT	10uF	20%	63V	C499	1-162-290-31	CERAMIC	470PF	10%	50V
C343	1-162-306-11	CERAMIC	0.01uF	20%	16V	C501	1-136-165-00	FILM	0.1uF	5%	50V
C344	1-162-306-11	CERAMIC	0.01uF	20%	16V	C503	1-162-199-31	CERAMIC	10PF	5%	50V
C345	1-162-209-31	CERAMIC	27PF	5%	50V	C504	1-126-023-11	ELECT	100uF	20%	25V
C346	1-162-205-31	CERAMIC	18PF	5%	50V	C505	1-162-211-31	CERAMIC	33PF	5%	50V
C347	1-162-294-31	CERAMIC	0.001uF	10%	50V	C506	1-162-199-31	CERAMIC	10PF	5%	50V

When indicating parts by reference number, please include the board name.

MAIN

Ref. No.	Part No.	Description	Remarks	Ref. No.	Part No.	Description	Remarks
C507	1-136-153-00	FILM	0.01uF 5% 50V	* CN107	1-564-509-11	PLUG, CONNECTOR 6P	
C508	1-136-158-00	FILM	0.027uF 5% 50V	* CN301	1-564-706-11	PIN, CONNECTOR (SMALL TYPE) 4P	
C509	1-126-023-11	ELECT	100uF 20% 25V	* CN308	1-564-339-00	PIN, CONNECTOR 5P	
C511	1-136-165-00	FILM	0.1uF 5% 50V	* CN333	1-564-514-11	PLUG, CONNECTOR 11P	
C512	1-164-159-11	CERAMIC	0.1uF 50V	* CN398	1-564-336-00	PIN, CONNECTOR 2P	
C513	1-126-023-11	ELECT	100uF 20% 25V	* CN501	1-564-716-11	PIN, CONNECTOR (SMALL TYPE)14P	
C514	1-136-165-00	FILM	0.1uF 5% 50V	* CN508	1-568-933-11	SOCKET, CONNECTOR 30P	
C515	1-136-169-00	FILM	0.22uF 5% 50V	* CN571	1-568-829-11	SOCKET, CONNECTOR 10P	
C516	1-136-158-00	FILM	0.027uF 5% 50V	* CN572	1-568-825-11	SOCKET, CONNECTOR 6P	
C517	1-164-159-11	CERAMIC	0.1uF 50V	* CN576	1-564-336-00	PIN, CONNECTOR 2P	
C555	1-162-179-11	CERAMIC	0.1uF 50V	< COMPOSITION CIRCUIT BLOCK >			
C601	1-126-023-11	ELECT	100uF 20% 25V	CP601	1-233-006-11	COMPOSITION CIRCUIT BLOCK (100K X 10)	
C602	1-126-023-11	ELECT	100uF 20% 25V	< DIODE >			
C603	1-126-023-11	ELECT	100uF 20% 25V	D101	8-719-107-94	DIODE 1SS202-1	
C604	1-126-023-11	ELECT	100uF 20% 25V	D102	8-719-107-94	DIODE 1SS202-1	
C605	1-126-023-11	ELECT	100uF 20% 25V	D201	8-719-107-94	DIODE 1SS202-1	
C606	1-126-023-11	ELECT	100uF 20% 25V	D202	8-719-107-94	DIODE 1SS202-1	
C607	1-126-023-11	ELECT	100uF 20% 25V	D306	8-719-200-82	DIODE 11ES2	
C608	1-126-023-11	ELECT	100uF 20% 25V	D307	8-719-107-94	DIODE 1SS202-1	
C609	1-126-023-11	ELECT	100uF 20% 25V	D308	8-719-107-94	DIODE 1SS202-1	
C610	1-136-165-00	FILM	0.1uF 5% 50V	D314	8-719-200-82	DIODE 11ES2	
C612	1-136-165-00	FILM	0.1uF 5% 50V	D321	8-719-107-94	DIODE 1SS202-1	
C613	1-136-165-00	FILM	0.1uF 5% 50V	D322	8-719-911-06	DIODE 1SS106	
C614	1-136-165-00	FILM	0.1uF 5% 50V	D324	8-719-911-06	DIODE 1SS106	
C615	1-162-179-11	CERAMIC	0.1uF 50V	D350	8-719-107-94	DIODE 1SS202-1	
C616	1-136-165-00	FILM	0.1uF 5% 50V	D403	8-719-107-94	DIODE 1SS202-1	
C617	1-136-165-00	FILM	0.1uF 5% 50V	D501	8-719-918-45	DIODE KV1310	
C618	1-136-165-00	FILM	0.1uF 5% 50V	D503	8-719-903-27	DIODE 1SS168	
C619	1-162-179-11	CERAMIC	0.1uF 50V	D601	8-719-114-27	DIODE RD4. 7JS-B3	
C620	1-162-179-11	CERAMIC	0.1uF 50V	D602	8-719-107-94	DIODE 1SS202-1	
C621	1-136-165-00	FILM	0.1uF 5% 50V	D603	8-719-114-30	DIODE RD5. 1JS-B2	
C622	1-136-165-00	FILM	0.1uF 5% 50V	< IC >			
C623	1-136-165-00	FILM	0.1uF 5% 50V	IC101	8-759-602-83	IC M5238P	
C624	1-126-023-11	ELECT	100uF 20% 25V	IC201	8-759-602-83	IC M5238P	
C630	1-164-159-11	CERAMIC	0.1uF 50V	IC301	8-759-917-18	IC SN74HC004AN	
C631	1-164-159-11	CERAMIC	0.1uF 50V	IC302	8-759-916-12	IC SN74HC00AN	
C632	1-164-159-11	CERAMIC	0.1uF 50V	IC303	8-759-921-10	IC SN74HC86AN	
C633	1-164-159-11	CERAMIC	0.1uF 50V	IC304	8-759-135-80	IC uPC358C	
C634	1-164-159-11	CERAMIC	0.1uF 50V	IC305	8-759-927-46	IC SN74HC00ANS	
C635	1-162-179-11	CERAMIC	0.1uF 25V	IC306	8-759-947-57	IC CXD1136Q	
C636	1-164-159-11	CERAMIC	0.1uF 50V	IC307	8-752-339-43	IC CXD2601AQ	
C637	1-164-159-11	CERAMIC	0.1uF 50V	IC308	8-759-906-24	IC SN74LS624N	
C638	1-164-159-11	CERAMIC	0.1uF 50V	IC309	8-759-925-90	IC SN74HC74ANS	
C639	1-164-159-11	CERAMIC	0.1uF 50V	IC310	8-752-337-80	IC CXK58257AM-12L	
C640	1-164-159-11	CERAMIC	0.1uF 50V	IC311	8-752-837-18	IC CXP80524-063Q	
C641	1-126-023-11	ELECT	100uF 20% 25V	IC312	8-752-837-17	IC CXP80524-062Q	
< CONNECTOR >				IC316	8-759-912-77	IC LM324N	
CN104	1-564-507-11	PLUG, CONNECTOR 4P					

When indicating parts by reference number, please include the board name.



## MAIN

Ref. No.	Part No.	Description	Remarks	Ref. No.	Part No.	Description	Remarks
IC318	8-759-135-80	IC	uPC358C				
IC319	8-759-633-65	IC	M54641L				
IC320	8-759-633-65	IC	M54641L				
IC321	8-759-520-90	IC	PST572E				
IC322	8-759-231-53	IC	TA7805S				
IC330	8-759-984-34	IC	RP5C62				
IC331	8-749-921-11	IC	GP1F32R (OPTICAL IN)				
IC332	8-749-921-12	IC	GP1F32T (OPTICAL OUT)				
IC333	8-759-917-18	IC	SN74HC04AN				
IC354	8-759-900-72	IC	NE5532P				
IC355	8-759-900-72	IC	NE5532P				
IC356	8-759-945-58	IC	RC4558P				
IC357	8-759-231-53	IC	TA7805S				
IC358	8-759-245-79	IC	TA79005S				
IC359	8-759-504-36	IC	CS5339-KP				
IC360	8-759-972-47	IC	LF412CN				
IC363	8-752-342-65	IC	CXD2560M				
IC375	8-759-900-72	IC	NE5532P				
IC376	8-759-900-72	IC	NE5532P				
IC431	8-759-925-78	IC	SN74HC10ANS				
IC432	8-759-510-43	IC	PST572C				
IC501	8-759-604-30	IC	M5F7808L				
IC502	8-759-925-74	IC	SN74HC04ANS				
IC503	8-759-926-95	IC	SN74HC4020ANS				
IC504	8-759-250-81	IC	TC5081AP				
IC601	8-759-044-10	IC	CXD2562Q				
IC602	8-759-900-72	IC	NE5532P				
< JACK >							
J101	1-568-751-61	JACK, PIN (2P SHIELD TYPE) (LINE IN)					
J102	1-568-751-61	JACK, PIN (2P SHIELD TYPE) (LINE OUT)					
J181	1-565-406-41	JACK, PIN 1P (COAXIAL OUT)					
J191	1-568-750-21	JACK, PIN (1P SHIELD TYPE) (COAXIAL IN)					
< COIL >							
L301	1-410-509-11	INDUCTOR	10uH				
L302	1-410-498-11	INDUCTOR	1.2uH				
L303	1-410-509-11	INDUCTOR	10uH				
L305	1-410-515-11	INDUCTOR	33uH				
L306	1-410-509-11	INDUCTOR	10uH				
L310	1-410-953-11	INDUCTOR, SMALL TYPE					
L320	1-236-101-11	ENCAPSULATED COMPONENT					
L329	1-236-101-11	ENCAPSULATED COMPONENT					
L501	1-426-850-11	COIL (RF)					
L502	1-410-509-11	INDUCTOR	10uH				
L504	1-410-509-11	INDUCTOR	10uH				
L505	1-426-850-11	COIL (RF)					
L602	1-239-235-21	ENCAPSULATED COMPONENT					
L603	1-410-397-21	FERRITE BEAD INDUCTOR					
L604	1-236-058-21	ENCAPSULATED COMPONENT					
< TRANSISTOR >							
Q301	8-729-927-11	TRANSISTOR	2SA1585S-QR				
Q302	8-729-801-93	TRANSISTOR	2SD1387-3				
Q311	8-729-900-80	TRANSISTOR	DTC114ES				
Q312	8-729-620-05	TRANSISTOR	2SC2603-EF				
Q313	8-729-900-61	TRANSISTOR	DTA114ES				
Q318	8-729-900-80	TRANSISTOR	DTC114ES				
Q319	8-729-900-80	TRANSISTOR	DTC114ES				
Q320	8-729-927-11	TRANSISTOR	2SA1585S-QR				
Q321	8-729-927-12	TRANSISTOR	2SC4115S-QR				
Q333	8-729-141-83	TRANSISTOR	2SB1094-LK				
Q334	8-729-119-76	TRANSISTOR	2SA1175-HFE				
Q335	8-729-620-05	TRANSISTOR	2SC2603-EF				
Q336	8-729-927-11	TRANSISTOR	2SA1585S-QR				
Q337	8-729-927-11	TRANSISTOR	2SA1585S-QR				
Q338	8-729-927-12	TRANSISTOR	2SC4115S-QR				
Q339	8-729-927-12	TRANSISTOR	2SC4115S-QR				
Q340	8-729-900-80	TRANSISTOR	DTC114ES				
Q341	8-729-900-80	TRANSISTOR	DTC114ES				
Q342	8-729-209-15	TRANSISTOR	2SD2012				
Q432	8-729-900-80	TRANSISTOR	DTC114ES				
Q433	8-729-107-85	TRANSISTOR	2SC3623A-K				
Q434	8-729-107-85	TRANSISTOR	2SC3623A-K				
Q435	8-729-900-61	TRANSISTOR	DTA114ES				
Q436	8-729-900-80	TRANSISTOR	DTC114ES				
Q437	8-729-900-61	TRANSISTOR	DTA114ES				
Q438	8-729-900-80	TRANSISTOR	DTC114ES				
Q439	8-729-900-80	TRANSISTOR	DTC114ES				
Q440	8-729-620-05	TRANSISTOR	2SC2603-EF				
Q499	8-729-900-80	TRANSISTOR	DTC114ES				
Q501	8-729-200-56	TRANSISTOR	2SK241-GR				
Q502	8-729-200-56	TRANSISTOR	2SK241-GR				
Q503	8-729-900-61	TRANSISTOR	DTA114ES				
Q601	8-729-140-96	TRANSISTOR	2SD774-34				
Q602	8-729-140-96	TRANSISTOR	2SD774-34				
Q603	8-729-119-76	TRANSISTOR	2SA1175-HFE				
< RESISTOR >							
R102	1-247-903-00	CARBON	1M 5%	1/4W			
R103	1-249-421-11	CARBON	2.2K 5%	1/4W			
R104	1-249-434-11	CARBON	27K 5%	1/4W			
R105	1-249-435-11	CARBON	33K 5%	1/4W			
R106	1-249-403-11	CARBON	68 5%	1/4W			
R107	1-247-854-11	CARBON	9.1K 5%	1/4W			
R108	1-247-854-11	CARBON	9.1K 5%	1/4W			
R109	1-247-854-11	CARBON	9.1K 5%	1/4W			
R110	1-247-854-11	CARBON	9.1K 5%	1/4W			
R111	1-247-844-11	CARBON	3.6K 5%	1/4W			
R112	1-247-844-11	CARBON	3.6K 5%	1/4W			

When indicating parts by reference number, please include the board name.

## MAIN

Ref. No.	Part No.	Description	Remarks	Ref. No.	Part No.	Description	Remarks
R115	1-249-429-11	CARBON	10K 5% 1/4W	R312	1-249-421-11	CARBON	2. 2K 5% 1/4W
R116	1-249-429-11	CARBON	10K 5% 1/4W	R313	1-249-421-11	CARBON	2. 2K 5% 1/4W
R117	1-249-426-11	CARBON	5. 6K 5% 1/4W	R314	1-249-435-11	CARBON	33K 5% 1/4W
R118	1-249-426-11	CARBON	5. 6K 5% 1/4W	R315	1-249-429-11	CARBON	10K 5% 1/4W
R119	1-249-426-11	CARBON	5. 6K 5% 1/4W	R316	1-247-804-11	CARBON	75 5% 1/4W
R120	1-249-426-11	CARBON	5. 6K 5% 1/4W	R317	1-249-405-11	CARBON	100 5% 1/4W
R122	1-247-836-11	CARBON	1. 6K 5% 1/4W	R318	1-249-409-11	CARBON	220 5% 1/4W
R123	1-247-836-11	CARBON	1. 6K 5% 1/4W	R319	1-249-409-11	CARBON	220 5% 1/4W
R124	1-249-441-11	CARBON	100K 5% 1/4W	R321	1-249-405-11	CARBON	100 5% 1/4W
R125	1-249-409-11	CARBON	220 5% 1/4W	R322	1-249-429-11	CARBON	10K 5% 1/4W
R126	1-249-429-11	CARBON	10K 5% 1/4W	R323	1-249-433-11	CARBON	22K 5% 1/4W
R127	1-249-405-11	CARBON	100 5% 1/4W	R324	1-249-433-11	CARBON	22K 5% 1/4W
R153	1-247-806-11	CARBON	91 5% 1/4W	R325	1-249-425-11	CARBON	4. 7K 5% 1/4W
R180	1-249-397-11	CARBON	22 5% 1/4W	R326	1-249-409-11	CARBON	220 5% 1/4W
R202	1-247-903-00	CARBON	1M 5% 1/4W	R327	1-249-425-11	CARBON	4. 7K 5% 1/4W
R203	1-249-421-11	CARBON	2. 2K 5% 1/4W	R328	1-249-417-11	CARBON	1K 5% 1/4W
R204	1-249-434-11	CARBON	27K 5% 1/4W	R330	1-249-417-11	CARBON	1K 5% 1/4W
R205	1-249-435-11	CARBON	33K 5% 1/4W	R331	1-249-429-11	CARBON	10K 5% 1/4W
R206	1-249-403-11	CARBON	68 5% 1/4W	R332	1-249-429-11	CARBON	10K 5% 1/4W
R207	1-247-854-11	CARBON	9. 1K 5% 1/4W	R333	1-249-433-11	CARBON	22K 5% 1/4W
R208	1-247-854-11	CARBON	9. 1K 5% 1/4W	R334	1-249-425-11	CARBON	4. 7K 5% 1/4W
R209	1-247-854-11	CARBON	9. 1K 5% 1/4W	R335	1-249-425-11	CARBON	4. 7K 5% 1/4W
R210	1-247-854-11	CARBON	9. 1K 5% 1/4W	R336	1-249-425-11	CARBON	4. 7K 5% 1/4W
R211	1-247-844-11	CARBON	3. 6K 5% 1/4W	R337	1-249-429-11	CARBON	10K 5% 1/4W
R212	1-247-844-11	CARBON	3. 6K 5% 1/4W	R338	1-249-433-11	CARBON	22K 5% 1/4W
R215	1-249-429-11	CARBON	10K 5% 1/4W	R339	1-249-401-11	CARBON	47 5% 1/4W
R216	1-249-429-11	CARBON	10K 5% 1/4W	R340	1-247-881-00	CARBON	120K 5% 1/4W
R217	1-249-426-11	CARBON	5. 6K 5% 1/4W	R341	1-247-881-00	CARBON	120K 5% 1/4W
R218	1-249-426-11	CARBON	5. 6K 5% 1/4W	R342	1-247-881-00	CARBON	120K 5% 1/4W
R219	1-249-426-11	CARBON	5. 6K 5% 1/4W	R343	1-247-889-00	CARBON	270K 5% 1/4W
R220	1-249-426-11	CARBON	5. 6K 5% 1/4W	R344	1-247-887-00	CARBON	220K 5% 1/4W
R222	1-247-836-11	CARBON	1. 6K 5% 1/4W	R345	1-247-887-00	CARBON	220K 5% 1/4W
R223	1-247-836-11	CARBON	1. 6K 5% 1/4W	R346	1-249-441-11	CARBON	100K 5% 1/4W
R224	1-249-441-11	CARBON	100K 5% 1/4W	R347	1-249-441-11	CARBON	100K 5% 1/4W
R225	1-249-409-11	CARBON	220 5% 1/4W	R348	1-249-441-11	CARBON	100K 5% 1/4W
R226	1-249-429-11	CARBON	10K 5% 1/4W	R349	1-249-441-11	CARBON	100K 5% 1/4W
R227	1-249-405-11	CARBON	100 5% 1/4W	R350	1-249-435-11	CARBON	33K 5% 1/4W
R253	1-247-806-11	CARBON	91 5% 1/4W	R351	1-249-435-11	CARBON	33K 5% 1/4W
R280	1-249-397-11	CARBON	22 5% 1/4W	R352	1-249-441-11	CARBON	100K 5% 1/4W
R301	1-247-804-11	CARBON	75 5% 1/4W	R353	1-249-441-11	CARBON	100K 5% 1/4W
R302	1-249-437-11	CARBON	47K 5% 1/4W	R354	1-249-441-11	CARBON	100K 5% 1/4W
R303	1-249-421-11	CARBON	2. 2K 5% 1/4W	R355	1-249-417-11	CARBON	1K 5% 1/4W
R304	1-249-441-11	CARBON	100K 5% 1/4W	R356	1-249-417-11	CARBON	1K 5% 1/4W
R305	1-249-421-11	CARBON	2. 2K 5% 1/4W	R357	1-249-405-11	CARBON	100 5% 1/4W
R306	1-249-417-11	CARBON	1K 5% 1/4W	R358	1-249-417-11	CARBON	1K 5% 1/4W
R307	1-249-417-11	CARBON	1K 5% 1/4W	R359	1-249-408-11	CARBON	180 5% 1/4W
R308	1-249-425-11	CARBON	4. 7K 5% 1/4W	R360	1-215-447-00	METAL	12K 1% 1/6W
R309	1-249-421-11	CARBON	2. 2K 5% 1/4W	R361	1-215-447-00	METAL	12K 1% 1/6W
R310	1-249-441-11	CARBON	100K 5% 1/4W	R364	1-249-406-11	CARBON	120 5% 1/4W
R311	1-249-429-11	CARBON	10K 5% 1/4W	R365	1-249-425-11	CARBON	4. 7K 5% 1/4W

When indicating parts by reference number, please include the board name.



**MAIN MOTOR POWER RELAY PRIMARY**

Ref. No.	Part No.	Description	Remarks	Ref. No.	Part No.	Description	Remarks
		< COIL >					
T301	1-459-795-11	COIL (WITH CORE)		* CN906	1-560-061-00	PIN, CONNECTOR 3P	
		< VIBRATOR >		* CN931	1-564-505-11	PLUG, CONNECTOR 2P	
X301	1-567-816-11	VIBRATOR, CRYSTAL (18.816MHz)		* CN932	1-564-511-11	PLUG, CONNECTOR 8P	
X302	1-567-815-11	VIBRATOR, CRYSTAL (22.5792MHz)		* CN933	1-564-506-11	PLUG, CONNECTOR 3P	
X303	1-578-667-11	VIBRATOR, CRYSTAL (49.152MHz)				< DIODE >	
X304	1-567-098-00	OSCILLATOR, CRYSTAL (32.768kHz)		D905	8-719-312-47	DIODE RBA-406B	
*****				D906	8-719-107-94	DIODE 1SS202-1	
*	1-641-486-11	MOTOR BOARD		D907	8-719-200-82	DIODE 11ES2	
		*****		D908	8-719-200-82	DIODE 11ES2	
		< CAPACITOR >		D909	8-719-934-15	DIODE HZS24-3L	
C01	1-162-851-11	CERAMIC 0.1MF	16V	D910	8-719-933-33	DIODE HZS6A1L	
		< CONNECTOR >		D911	8-719-200-77	DIODE 10E2N	
* CN1	1-564-498-11	PIN, CONNECTOR 5P		D912	8-719-200-77	DIODE 10E2N	
* CN2	1-564-337-00	PIN, CONNECTOR 3P		D913	8-719-200-77	DIODE 10E2N	
*****				D914	8-719-200-77	DIODE 10E2N	
*	A-2006-819-A	POWER BOARD, COMPLETE		D915	8-719-107-94	DIODE 1SS202-1	
		*****		D916	8-719-107-94	DIODE 1SS202-1	
		< CAPACITOR >				< FUSE >	
C907	1-126-946-11	ELECT 6800uF 20%	25V	△F901	1-532-744-11	FUSE, GLASS TUBE (2.5A) (US, Canadian)	
C908	1-136-165-00	FILM 0.1uF 5%	50V	△F901	1-532-286-11	FUSE, TIME-LAG (T2.5A) (AEP, E)	
C909	1-124-473-11	ELECT 1000uF 20%	10V			< IC >	
C910	1-164-159-11	CERAMIC 0.1uF	50V	IC901	8-759-148-79	IC uPC2406HF	
C911	1-164-159-11	CERAMIC 0.1uF	50V	IC902	8-759-231-53	IC TA7805S	
C912	1-124-473-11	ELECT 1000uF 20%	10V	IC903	8-759-231-58	IC TA7812S	
C913	1-126-104-11	ELECT 470uF 20%	35V	IC904	8-759-245-86	IC TA79012S	
C914	1-126-104-11	ELECT 470uF 20%	35V			< TRANSISTOR >	
C915	1-126-049-11	ELECT 22uF 20%	50V	Q901	8-729-140-97	TRANSISTOR 2SB734-34	
C916	1-126-052-11	ELECT 100uF 20%	50V			< RESISTOR >	
C917	1-136-165-00	FILM 0.1uF 5%	50V	R901	1-249-425-11	CARBON 4.7K 5% 1/4W	
C918	1-130-834-00	FILM 1uF 10%	63V	△R902	1-212-849-00	FUSIBLE 4.7 5% 1/4W F	
C919	1-136-165-00	FILM 0.1uF 5%	50V	R903	1-249-421-11	CARBON 2.2K 5% 1/4W	
C920	1-128-468-51	ELECT 4700uF 20%	25V	△R904	1-212-865-00	FUSIBLE 22 5% 1/4W F	
C921	1-128-468-51	ELECT 4700uF 20%	25V	R905	1-249-433-11	CARBON 22K 5% 1/4W	
C922	1-136-165-00	FILM 0.1uF 5%	50V	*****			
C923	1-136-165-00	FILM 0.1uF 5%	50V	*	1-645-235-11	RELAY BOARD	
C924	1-136-165-00	FILM 0.1uF 5%	50V			*****	
C925	1-136-165-00	FILM 0.1uF 5%	50V	*****			
C926	1-126-105-11	ELECT 1000uF 20%	35V	*	1-645-234-11	PRIMARY BOARD	
C927	1-126-105-11	ELECT 1000uF 20%	35V			*****	
		< CONNECTOR >		*	3-346-266-12	PLATE, GROUND	
* CN905	1-560-338-00	PIN, CONNECTOR 7P					

The components identified by mark △ or dotted line with mark △ are critical for safety. Replace only with part number specified.

Les composants identifiés par une marque △ sont critiques pour la sécurité. Ne les remplacer que par une pièce portant le numéro spécifié.

When indicating parts by reference number, please include the board name.

**PRIMARY      REC VOL      REEL MOTOR      RF AMP**

Ref. No.	Part No.	Description	Remarks
< CAPACITOR >			
△C901	1-161-744-00	CERAMIC 0.01uF	400V
△C902	1-161-742-00	CERAMIC 0.0022uF 20%	400V
△C903	1-161-742-00	CERAMIC 0.0022uF 20%	400V
△C904	1-161-742-00	CERAMIC 0.0022uF 20%	400V
△C905	1-161-742-00	CERAMIC 0.0022uF 20%	400V(AEP, E)
△C906	1-161-744-00	CERAMIC 0.01uF	400V
< CONNECTOR >			
* CN901	1-564-321-00	PIN, CONNECTOR 2P	
CN902	1-564-321-00	PIN, CONNECTOR 2P	
< COIL >			
△L901	1-421-915-11	COIL, LINE FILTER	
< SWITCH >			
△S921	1-571-722-11	SWITCH, VOLTAGE SELECTION (VOLTAGE SELECTOR) (E)	
*****			
*	1-645-239-11	REC VOL BOARD *****	
< CONNECTOR >			
* CN102	1-564-519-11	PLUG, CONNECTOR 4P	
< RESISTOR >			
R101	1-259-462-11	CARBON 27K 5%	1/6W
R201	1-259-462-11	CARBON 27K 5%	1/6W
< VARIABLE RESISTOR >			
RV101	1-241-937-11	RES, VAR, CARBON 20K/20K (REC LEVEL)	
*****			
*	1-639-304-11	REEL MOTOR BOARD *****	
< CAPACITOR >			
C07	1-163-077-00	CERAMIC CHIP 0.1uF	10% 25V
*****			
RF AMP BOARD, COMPLETE *****			
< CAPACITOR >			
C1	1-124-778-00	ELECT CHIP 22uF	20% 6.3V
C2	1-163-019-00	CERAMIC CHIP 0.0068uF	10% 50V
C3	1-163-117-00	CERAMIC CHIP 100PF	5% 50V
C4	1-162-638-11	CERAMIC CHIP 1uF	16V

Ref. No.	Part No.	Description	Remarks
C5	1-164-299-11	CERAMIC CHIP 0.22uF	10% 25V
C6	1-164-004-11	CERAMIC CHIP 0.1uF	10% 25V
C7	1-163-009-11	CERAMIC CHIP 0.001uF	10% 50V
C8	1-124-778-00	ELECT CHIP 22uF	20% 6.3V
C9	1-124-778-00	ELECT CHIP 22uF	20% 6.3V
C10	1-163-009-11	CERAMIC CHIP 0.001uF	10% 50V
C11	1-164-004-11	CERAMIC CHIP 0.1uF	10% 25V
C12	1-164-299-11	CERAMIC CHIP 0.22uF	10% 25V
C13	1-162-638-11	CERAMIC CHIP 1uF	16V
C14	1-163-117-00	CERAMIC CHIP 100PF	5% 50V
C15	1-124-778-00	ELECT CHIP 22uF	20% 6.3V
C16	1-163-038-00	CERAMIC CHIP 0.1uF	25V
C17	1-163-001-11	CERAMIC CHIP 220PF	10% 50V
C18	1-163-117-00	CERAMIC CHIP 100PF	5% 50V
C19	1-163-001-11	CERAMIC CHIP 220PF	10% 50V
C20	1-164-182-11	CERAMIC CHIP 0.0033uF	10% 50V
C21	1-163-005-11	CERAMIC CHIP 470PF	10% 50V
C22	1-126-603-11	ELECT CHIP 4.7uF	20% 35V
C23	1-163-117-00	CERAMIC CHIP 100PF	5% 50V
C24	1-163-038-00	CERAMIC CHIP 0.1uF	25V
C25	1-124-778-00	ELECT CHIP 22uF	20% 6.3V
C26	1-163-038-00	CERAMIC CHIP 0.1uF	25V
C27	1-162-638-11	CERAMIC CHIP 1uF	16V
C28	1-164-505-11	CERAMIC CHIP 2.2uF	16V
< CONNECTOR >			
* CN51	1-566-207-11	PIN, CONNECTOR (PC BOARD) 14P	
* CN52	1-564-720-11	PIN, CONNECTOR (SMALL TYPE) 4P	
< IC >			
IC1	8-752-039-01	IC CXA1364R	
< COIL >			
L1	1-408-781-00	INDUCTOR CHIP 22uH	
L2	1-408-789-21	INDUCTOR CHIP 100uH	
L3	1-408-781-00	INDUCTOR CHIP 22uH	
< RESISTOR >			
R1	1-216-082-00	METAL GLAZE 24K 5%	1/10W
R2	1-216-082-00	METAL GLAZE 24K 5%	1/10W
R3	1-216-066-00	METAL CHIP 5.1K 5%	1/10W
R4	1-216-066-00	METAL CHIP 5.1K 5%	1/10W
R5	1-216-077-00	METAL CHIP 15K 5%	1/10W
R6	1-216-077-00	METAL CHIP 15K 5%	1/10W
R7	1-216-077-00	METAL CHIP 15K 5%	1/10W
R8	1-216-079-00	METAL CHIP 18K 5%	1/10W
R9	1-216-075-00	METAL CHIP 12K 5%	1/10W
R10	1-216-079-00	METAL CHIP 18K 5%	1/10W
R11	1-216-077-00	METAL CHIP 15K 5%	1/10W

The components identified by mark △ or dotted line with mark △ are critical for safety. Replace only with part number specified.

Les composants identifiés par une marque △ sont critiques pour la sécurité. Ne les remplacer que par une pièce portant le numéro spécifié.

When indicating parts by reference number, please include the board name.

**RF AMP**

**RGN SW**

**SW**

**TIMER SW**

**TOP END SENSOR**

Ref. No.	Part No.	Description	Remarks
R12	1-216-077-00	METAL CHIP	15K 5% 1/10W
R13	1-216-077-00	METAL CHIP	15K 5% 1/10W
R14	1-216-081-00	METAL CHIP	22K 5% 1/10W
R15	1-216-085-00	METAL CHIP	33K 5% 1/10W
R16	1-216-089-00	METAL CHIP	47K 5% 1/10W
< VARIABLE RESISTOR >			
RV1	1-238-181-11	RES, ADJ, CERMET 4.7K	
RV2	1-238-181-11	RES, ADJ, CERMET 4.7K	
*****			
*	1-639-301-11	RGN SW BOARD	*****
< SWITCH >			
S01	1-571-878-11	SWITCH, PUSH (2 KEY) (CASSETTE IN/REC PROOF)	
*****			
*	1-641-487-11	SW BOARD	*****
< SWITCH >			
S1	1-571-958-11	SWITCH, PUSH (1 KEY) (CASSETTE TABLE IN)	
S2	1-571-958-11	SWITCH, PUSH (1 KEY) (CASSETTE TABLE OUT)	
*****			
*	1-645-243-11	TIMER SW BOARD	*****
< RESISTOR >			
R704	1-249-427-11	CARBON	6.8K 5% 1/4W
R705	1-249-432-11	CARBON	18K 5% 1/4W
< SWITCH >			
S701	1-571-520-11	SWITCH, SLIDE (TIMER)	
S702	1-554-937-11	SWITCH, KEY BOARD ( ≡ OPEN/CLOSE)	
*****			
*	1-639-305-11	TOP END SENSOR BOARD	*****
*	3-368-456-01	HOLDER (END SENSOR LIGHT)	
*	3-368-457-01	HOLDER (END SENSOR) (RECIEVE)	
< DIODE >			
D01	8-719-988-42	DIODE GL453S	
< PHOTO INTERRUPTER >			
PH03	8-729-907-25	TRANSISTOR	PT4850F

Ref. No.	Part No.	Description	Remarks
PH04	8-729-907-25	TRANSISTOR	PT4850F
*****			
MISCELLANEOUS			
*****			
△10	1-559-297-31	CODE, POWER (E)	
△10	1-559-479-11	CORD, POWER (US, Canadian)	
△10	1-575-912-11	CORD, POWER (AEP)	
13	1-590-321-71	LEAD (WITH CONNECTOR) (CONTROL-S IN)	
107	1-533-183-11	HOLDER, FUSE	
114	1-590-915-11	WIRE, FLAT TYPE (30 CORE)	
118	1-590-916-11	WIRE, FLAT TYPE (10 CORE)	
119	1-590-914-11	WIRE, FLAT TYPE (6 CORE)	
325	8-848-567-11	DRUM ASSY DOU-03A	
M901	A-2003-910-A	MOTOR ASSY, CASSETTE (CASSETTE COMPARTMENT)	
M902	8-835-361-01	MOTOR, DC U-17B (CAPSTAN)	
M903	X-3363-109-1	MOTOR (CAM) ASSY	
M905	X-3363-110-1	MOTOR (REEL) ASSY	
PM902	1-454-536-11	SOLENOID, PLUNGER (BT CONTROL)	
PM903	1-454-535-11	SOLENOID, PLUNGER (BRAKE)	
△S901	1-554-920-21	SWITCH, PUSH (AC POWER) (1 KEY) (POWER)	
△T901	1-450-556-21	TRANSFORMER, POWER (US, Canadian)	
△T901	1-450-557-21	TRANSFORMER, POWER (AEP)	
△T901	1-450-558-21	TRANSFORMER, POWER (E)	
*****			
ACCESSORIES & PACKING MATERIALS			
*****			
1-465-737-11	REMOTE COMMANDER	(US, Canadian, E/AEP:BLACK)	
1-465-777-11	REMOTE COMMANDER (AEP:GOLD)		
1-558-271-11	CORD, CONNECTION		
3-704-366-01	SCREW (CASE) (M3X8)	(US, Canadian, E/AEP:BLACK)	
3-704-366-11	SCREW (CASE) (M3X8) (AEP:GOLD)		
3-707-584-01	COVER, BATTERY		
3-755-612-11	MANUAL, INSTRUCTION (ENGLISH, FRENCH, SPANISH, PORTUGUESE) (AEP, E)		
3-755-612-21	MANUAL, INSTRUCTION (ENGLISH)	(US, Canadian)	
3-755-612-31	MANUAL, INSTRUCTION (FRENCH) (Canadian)		
3-755-612-41	MANUAL, INSTRUCTION (GERMAN, DUTCH, SWEDISH, ITALIAN) (AEP)		
3-382-950-01	CUSHION		
3-383-048-01	INDIVIDUAL CARTON		
9-910-999-33	INSTRUCTION (US)		
*****			

<p>The components identified by mark △ or dotted line with mark △ are critical for safety. Replace only with part number specified.</p>	<p>Les composants identifiés par une marque △ sont critiques pour la sécurité. Ne les remplacer que par une pièce portant le numéro spécifié.</p>
---	---

When indicating parts by reference number, please include the board name.

<u>Ref. No.</u>	<u>Part No.</u>	<u>Description</u>	<u>Remarks</u>
-----------------	-----------------	--------------------	----------------

**HARDWARE LIST**

#1	7-682-548-09	SCREW +BVTT 3X8 (S)	
#2	7-685-646-79	SCREW +BVTP 3X8 TYPE2 N-S	
#3	7-685-134-19	SCREW (+ PTPWH) (2. 6X8)	
#4	7-685-534-19	SCREW +BTP 2. 6X8 TYPE2 N-S	
#5	7-685-645-19	SCREW +BVTP 3X8 TYPE2 N-S	
#6	7-685-133-19	SCREW +BTP 2. 6X6 TYPE2 N-S	
#7	7-682-147-15	SCREW, TR	
#8	7-621-775-20	SCREW +B 2. 6X5	
#9	7-682-560-04	SCREW +BVTT 4X6 (S)	
#10	7-682-547-04	SCREW +BVTT 3X6 (S)	
#11	7-621-772-00	SCREW +B 2X3	
#12	7-685-102-19	SCREW +P 2X4 TYPE2 NON-SLIT	
#13	7-621-773-86	SCREW +B 2. 6X4	
#14	7-627-556-17	SCREW, PRECISION +P 2. 6X3 TYPE1	
#15	7-621-772-08	SCREW +B 2X3	
#16	7-621-772-18	SCREW +B 2X4	
#17	7-627-552-47	SCREW, PRECISION +P 1. 7X4	
#18	7-621-255-20	SCREW +BVTT 2X4 (S)	
#19	7-627-854-07	PRECISION SCREW +P 2X2. 5 TYPE3	
#20	7-627-852-27	+P 1. 7X3	
#21	7-621-255-15	SCREW +P 2X3	
#22	7-627-552-27	SCREW, PRECISION +P 1. 7X2	





# DTC-59ES

## SONY SERVICE MANUAL

US Model  
Canadian Model  
AEP Model  
E Model

### SUPPLEMENT-2

File this supplement with the service manual.

Subject : • PARTS CHANGED  
• CORRECTION

(ECN-TC201118/TC500800, SPM-95029)

#### PARTS CHANGED

☛ : indicates changed portion.

Page	FORMER			NEW		
	Ref. No.	Part No.	Description	Ref. No.	Part No.	Description
60	307	3-368-428-01	SHAFT (ROLLER GUIDE)	307	3-908-644-01	SHAFT (ROLLER GUIDE)
				322	3-337-674-01	SHAFT, GUIDE
				338	3-337-674-01	NUT, ADJUSTMENT
				339	3-389-294-01	SPRING (T2 300G), COMPRESSION
61	* 359	3-368-411-01	SLIDER (REEL LOCK)	not used		

Revise your service manual as shown below due to parts supply classification has been changed.

Page	CURRENT			REVISED		
	Ref. No.	Part No.	Description	Ref. No.	Part No.	Description
60	309	X-3337-643-1	GUIDE (RIC) ASSY, ROLLER	309	X-3371-518-1	ROLLER GUIDE ASSY

**CORRECTION**

Correct your service manual as shown below.

● : indicates corrected portion.

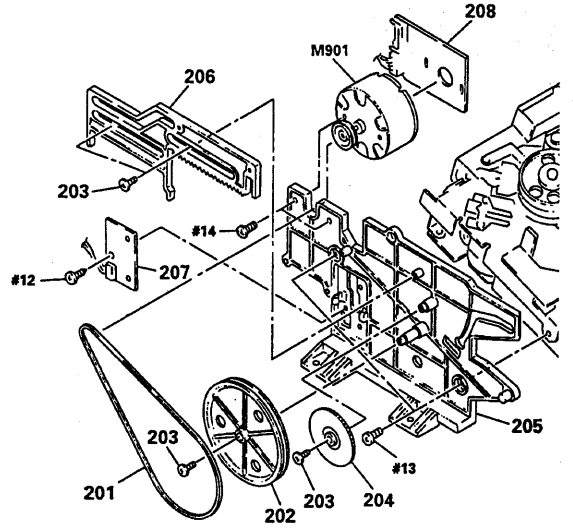
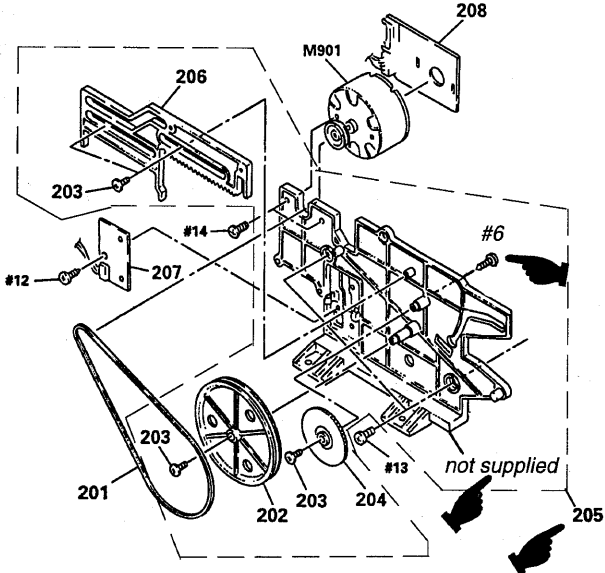
Page	INCORRECT			CORRECT										
59	<table border="1"> <thead> <tr> <th>Ref. No.</th> <th>Part No.</th> <th>Description</th> </tr> </thead> <tbody> <tr> <td>205</td> <td>3-373-234-04</td> <td>CHASSIS (L)</td> </tr> </tbody> </table> 	Ref. No.	Part No.	Description	205	3-373-234-04	CHASSIS (L)	<table border="1"> <thead> <tr> <th>Ref. No.</th> <th>Part No.</th> <th>Description</th> </tr> </thead> <tbody> <tr> <td>205</td> <td>A-2004-153-E</td> <td>CHASSIS (L) ASSY</td> </tr> </tbody> </table> 	Ref. No.	Part No.	Description	205	A-2004-153-E	CHASSIS (L) ASSY
Ref. No.	Part No.	Description												
205	3-373-234-04	CHASSIS (L)												
Ref. No.	Part No.	Description												
205	A-2004-153-E	CHASSIS (L) ASSY												

# DTC-59ES

## SONY SERVICE MANUAL

US Model  
Canadian Model  
AEP Model  
E Model

### CORRECTION-1

Correct your service manual as shown below.

 : Corrected portion

Page	Incorrect	Correct
15	<p><b>FWD Torque Adjustment</b> <b>Adjustment Procedure:</b></p> <p>3. Adjust RV601 so that the FWD torque value (take-up side rewinding torque) is between 10 – 13 g·cm (0.14 – 0.18 oz·inch).</p>	<p><b>FWD Torque Adjustment</b> <b>Adjustment Procedure:</b></p> <p>3. <u>Adjust RV601 so that the minimum value of FWD take up torque (take-up side rewinding torque) is between 10 – 11 g·cm (0.14 – 0.15 oz·inch). Also, make sure that the maximum reading does not exceed 16 g·cm (does not exceed 0.22 oz·inch).</u></p>
15	<p><b>FWD Back Tension Check and Adjustment</b> <b>Check procedure:</b></p> <p>3. Confirm that the back tension (supply side) is between 5 – 6 g·cm (0.07 – 0.09 oz·inch). If this is not satisfied, adjust back tension by rotating the FWD back tension adjustment screw equipped on the side surface of the mechanical deck. After completion of adjusting, be sure to apply screw lock.</p>	<p><b>FWD Back Tension Adjustment</b> <b>Adjustment procedure:</b></p> <p>3. <u>Turn the FWD back tension adjustment screw locked on the mechanical deck side so that the minimum value of FWD back tension torque (supply side) is between 4 – 5 g·cm (0.06 – 0.07 oz·inch).</u> <u>Also, make sure that the maximum reading does not exceed 8 g·cm (does not exceed 0.11 oz·inch).</u> After completion of adjusting, be sure to apply screw lock.</p>

# DTC-59ES

## SONY SERVICE MANUAL

US Model  
Canadian Model  
AEP Model  
E Model

### CORRECTION-2

Correct your service manual as shown below.

 : indicates corrected portion.

Page	INCORRECT	CORRECT
60	