

DTC-670

SERVICE MANUAL

US Model
Canadian Model
AEP Model

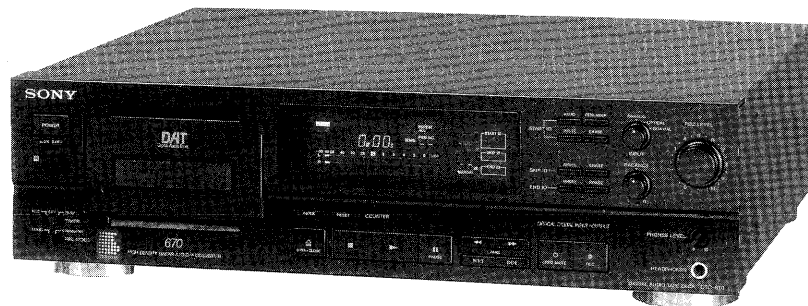

SPECIFICATIONS

Tape	Digital audio tape
Recording head	Rotary head
Recording time	Standard: 120 minutes. Long-play mode: 240 minutes (with DT-120)
Tape speed	Standard: 8.15 mm/s, Long play mode: 4.075 mm/s
Drum rotation	Standard: 2,000 rpm, Long-play mode: 1,000 rpm
Error correction	Double Read Solomon code
Tape	
Track pitch	13.6 μ m (20.4 μ m)
Sampling frequency	48 kHz, 44.1 kHz, 32 kHz
Modulation system	8-10 Modulation
Transfer rate	2.46 Mbit/sec.
Number of channel	2 channels, stereo
D/A conversion (Quantization)	Standard: 16-bit linear Long-play mode: 12-bit non-linear
Frequency response	Standard: 2-22,000 Hz (± 0.5 dB) Long-play mode: 2-14,500 Hz (± 0.5 dB)
Signal to noise ratio	Standard: more than 90 dB Long-play mode: more than 90 dB
Dynamic range	Standard: more than 90 dB Long-play mode: more than 90 dB
Total harmonic distortion	Standard: less than 0.005% (1 kHz) Long-play mode: less than 0.08% (1 kHz) Below measurable limit ($\pm 0.001\%$ W. PEAK)

Model Name Using Similar Mechanism	DTC-57ES
Tape Transport Mechanism Type	DATM-100

Wow and flutter

Input

	Jack type	Impedance	Rated input level
LINE IN	phono jack	47 kohms	-4 dBs
DIGITAL IN	phono jack	75 ohms	0.5 Vp-p, 20%
DIGITAL IN	optical jack	—	—

Output

	Jack type	Impedance	Rated output	Load impedance
LINE OUT	phono jack	470 ohms	-4 dBs	More than 10 kohms
PHONES	stereo phone jack	220 ohms	1.3 mW	32 ohms

DIGITAL OUT (optical jack): wavelength 660 nm

- continued on next page -

DIGITAL AUDIO TAPE DECK
SONY®



General

Power requirements	120V AC, 60Hz (US, Canadian model) 220 - 230V AC, 50/60Hz (AEP, Germany model)
Power consumption	32 W
Dimensions	Approx. 430x125x350 mm (w/h/d) (17 x 5 x 13 ⁷ / ₈ inches)
Weight	Approx. 7 kg (15 lb 14 oz)
Remote commander (supplied)	
Remote control system	Infrared control
Power requirements	3V DC, with two size AA (R6) batteries
Dimensions	Approx. 63x19x175 mm (w/h/d) (2 ¹ / ₂ x ³ / ₄ x 7 inches)
Weight	Approx. 130 g (4 oz) incl. batteries.

Supplied accessories

Sony batteries SUM-3(NS) (2)
Audio connecting cords (2 phono plugs - 2 phono plugs,
stereo for line inputs and outputs) (2)

Design and specifications subject to change without notice.

SAFETY-RELATED COMPONENT WARNING!!

COMPONENTS IDENTIFIED BY MARK Δ OR DOTTED LINE WITH MARK Δ ON THE SCHEMATIC DIAGRAMS AND IN THE PARTS LIST ARE CRITICAL TO SAFE OPERATION. REPLACE THESE COMPONENTS WITH SONY PARTS WHOSE PART NUMBERS APPEAR AS SHOWN IN THIS MANUAL OR IN SUPPLEMENTS PUBLISHED BY SONY.

ATTENTION AU COMPOSANT AYANT RAPPORT À LA SÉCURITÉ!

LES COMPOSANTS IDENTIFIÉS PAR UNE MARQUE Δ SUR LES DIAGRAMMES SCHÉMATIQUES ET LA LISTE DES PIÈCES SONT CRITIQUES POUR LA SÉCURITÉ DE FONCTIONNEMENT. NE REMPLACER SES COMPOSANTS QUE PAR DES PIÈCES SONY DONT LES NUMÉROS SONT DONNÉS DANS CE MANUEL OU DANS LES SUPPLÉMENTS PUBLIÉS PAR SONY.

TABLE OF CONTENTS

<u>Section</u>	<u>Title</u>	<u>Page</u>
1. GENERAL		
	Features	3
	Location and Function of Controls	4
	Connections	5
2. DISASSEMBLY		7
3. ADJUSTMENTS		10
3-1.	Electrical Adjustments	12
4. DIAGRAMS		
4-1.	Circuit Boards Location	15
4-2.	Block Diagram	16
4-3.	Waveforms	19
4-4.	Semiconductor Lead Layouts	21
4-5.	Printed Wiring Boards - MD / Power supply / Display section -	23
4-6.	Schematic Diagram - MD / Power supply / Display section -	27
4-7.	Printed Wiring Boards - Main section -	32
4-8.	Schematic Diagram - Main section -	35
4-9.	IC Block Diagrams	39
4-10.	Pin Functions	43
5. EXPLODED VIEWS		
5-1.	Cabinet Section	51
5-2.	Front Panel Section	52
5-3.	Chassis Section	53
5-4.	Mechanism Section 1	54
5-5.	Mechanism Section 2	55
5-6.	Mechanism Section 3	56
5-7.	Mechanism Section 4	57
6. ELECTRICAL PARTS LIST		58

PRECAUTIONS FOR INSPECTIONS AND REPAIR WITH POWER OFF

Before beginning repair work after turning OFF the main switch, be sure to first remove CN932 (EH8P) of the power board. When assembling the equipment, be sure to plug this connector last.

This is because, even with the main switch turned OFF, electric charges still remain in the smoothing capacitor in the power board. Therefore, if another flexible board is inserted or removed, a terminal of the power supply may short an adjacent terminal while destroying the device.

SAFETY CHECK-OUT

After correcting the original service problem, perform the following safety check before releasing the set to the customer: Check the antenna terminals, metal trim, "metallized" knobs, screws, and all other exposed metal parts for AC leakage. Check leakage as described below.

LEAKAGE TEST

The AC leakage from any exposed metal part to earth ground and from all exposed metal parts to any exposed metal part having a return to chassis, must not exceed 0.5mA (500 microamperes). Leakage current can be measured by any one of three methods.

1. A commercial leakage tester, such as the Simpson 229 or RCA WT-540A. Follow the manufacturers' instructions to use these instruments.
2. A battery-operated AC milliammeter. The Data Precision 245 digital multimeter is suitable for this job.
3. Measuring the voltage drop across a resistor by means of a

VOM or battery-operated AC voltmeter. The "limit" indication is 0.75V, so analog meters must have an accurate low-voltage scale. The Simpson 250 and Sanwa SH-63Trd are examples of a passive VOM that is suitable. Nearly all battery operated digital multimeters that have a 2V AC range are suitable. (See Fig.A)

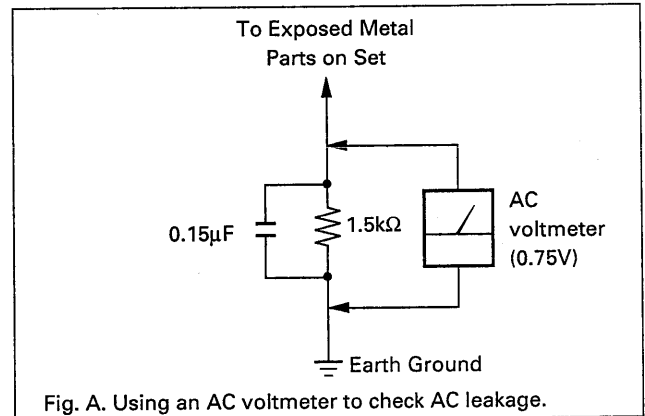

Fig. A. Using an AC voltmeter to check AC leakage.

This section is extracted from instruction manual.

SECTION 1 GENERAL

Overview of the Digital Audio Tape Deck

Serial copy management system

This unit utilizes the serial copy management system that permits digital-to-digital recording for one generation. You can record CD sound or other digital formats through a digital-to-digital connection. (See page 36.)

Three sampling frequencies

Recording/playback can be done with three sampling frequencies (48 kHz, 44.1 kHz and 32 kHz).
 48 kHz: For analog and digital input signals in a standard mode.
 44.1 kHz: For compact disc and pre-recorded DAT tape.
 32 kHz: For analog input signals in a long-play mode.

Long play mode

This unit can operate in a long-play mode. Analog input signals can be recorded or playback for up to four consecutive hours when the DT-120 DAT cassette tape is used. The sampling frequency will be 32 kHz in the long play mode.

Visible cassette loading

You can view the tape operation through the lid of the cassette compartment. Due to a revolutionary new transport mechanism, cassette loading time has been significantly reduced.

Excellent sound quality

- **1-bit A/D converter**
For the A/D converter section which converts analog input signals to digital signals, the unit employs a 1-bit A/D converter which theoretically generates no zero-cross distortion for a clear, elegant sound quality.
- **Pulse D/A converter**
Superior playback performance is achieved with a 1-bit D/A converter.

Rich variety of subcode information

This unit can record subcode information such as Start IDs, program numbers, Skip IDs, and absolute time data, enabling you to quickly locate tunes and display the playback time in the same manner as when playing compact discs.

Post edit recording of sub codes

You can record or rewrite the following sub codes after the audio signal recording has been completed.
 Start ID: Signifies the beginning of a selection.
 Program number: Gives a number to the selection.
 Skip ID: Signifies the beginning of a portion to be skipped.
 End ID: Signifies the end position of recording/playback.
 Since sub codes are written on the tape separately from audio signals, the audio signals are not affected.

Identifying Parts and Controls

This section describes the names and functions of each parts of this unit. Before operating this unit, please read carefully.

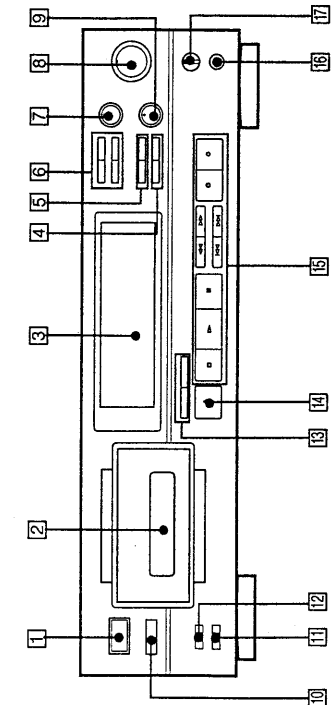

Front Panel/Remote Commander

- 1 POWER switch**
Turns the power on and off.
- 2 Cassette compartment**
Insert a cassette with the window side up and the safety tab facing you.
- 3 Display window**
- 4 END ID buttons**
WRITE: Press to write the ID signifying the end of playback or recording.
ERASE: Press to erase the end ID.
- 5 SKIP ID buttons**
WRITE: Press at the beginning of the portion you may wish to skip later. A skip ID will be written from the point where you pressed this button.
ERASE: Press to erase the nearest skip ID which is before the current position.
- 6 START ID buttons**
AUTO: Press to turn on and off the AUTO indicator. When the AUTO indicator is lit, the start ID will automatically be written during recording. When the AUTO indicator is not lit, press the START ID WRITE button at the point where you want to write a start ID.
WRITE: Press to write the start ID at the desired point during recording or playback.
ERASE: Press to erase a start ID. When a start ID and a program number are written on the tape, both codes are simultaneously erased by pressing this button.
RENUMBER: Press to renumber all programs on the tape. When only the start IDs are written, pressing this button will insert the proper program numbers beginning with "1". The tape will rewind and start from the beginning to accomplish this function.
- 7 INPUT selector**
Set according to the signal to be recorded.
ANALOG: For recording from the equipment connected to the LINE IN jacks.
OPTICAL: For recording from the equipment connected to the DIGITAL IN (OPTICAL) jack.
COAXIAL: For recording from the equipment connected to the DIGITAL IN (COAXIAL) jack.
- 8 REC LEVEL (recording level) control**
Adjust the recording level for the analog input signals. When recording digital signals, it is not necessary to adjust the recording level.

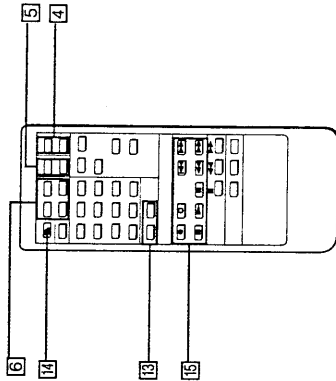

- 9 BALANCE control**
Adjust the recording balance for the analog input signals. When recording digital signals, it is not necessary to adjust the recording balance.
- 10 Remote sensor**
Receives the signal from the remote commander.
- 11 REC MODE selector**
Normally set to the STANDARD position. When this selector is set to the LONG position, you can record analog input signals or digital signals with 32 kHz in the long play mode.
- 12 TIMER switch**
Normally set to the OFF position. When recording or playing back at the desired time using a commercially available audio timer, set to the REC position or the PLAY position respectively.
- 13 COUNTER buttons**
MODE: Selects the counter display in the display window among the linear counter (tape running time), absolute time, elapsed time of the selection, and total remaining time of tape. Each time you press the button, the display changes sequentially.
RESET: Resets the linear counter to "00:00".
- 14 OPEN/CLOSE button**
Press to open or close the cassette compartment.
- 15 Tape operating buttons**
■ (stop): Press to stop recording or playback.
▶ (play): Press to play back the tape.
●REC (recording): Press to enter the record-pause mode. To start recording, press the **■PAUSE** or **▶** button.
■PAUSE (pause): Press to stop for a moment during recording or playback. To restart recording or playback, press this button again or press the **▶** button. If the unit is left in the pause mode for about 10 minutes, it will automatically be released and the deck will enter the stop mode. To restart recording or playback from the stop mode, press the **●REC** or **▶** button respectively.
OREC MUTE (record muting): Press to insert a sound-muted portion (space).
◀◀ (AMS): Press to locate the beginning of the selection during the playback.
◀◀ (rewind/review, fast-forward/cue): In the stop mode, press to rewind/fast-forward the tape. During playback, press to rewind or fast-forward the tape while listening to the sound.
- 16 Headphones jack**
Insert the headphones plug to this jack.
- 17 PHONE LEVEL control**
The PHONE LEVEL control adjusts the headphones volume level.

Identifying Parts and Controls

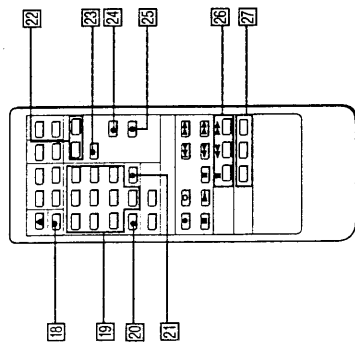

Front Panel/Remote Commander

- 18 DISPLAY MODE button**
Changes the display mode. (Refer to page 12.)
- 19 Numeric buttons (0-9)**
Designate the desired program number to be played back before starting playback.
Designate the desired number in the record-pause mode, the program number is written consecutively from the designated number.
- 20 CLEAR button**
Use to cancel the program number which has been mistakenly entered.
- 21 MUSIC SCAN button**
Use this feature to listen to the beginning of each selection successively.
- 22 RMS play buttons**
ENTER: To program the selections in a desired order, press this button after pressing the numeric buttons.
CHECK: Press to check the programmed contents.
- 23 REPEAT 1/ALL button**
Press to play a desired portion repeatedly. Each time you press the button, the indicator changes as follows:
REPEAT 1 → REPEAT ALL → off
- 24 MARGIN RESET button**
Press to reset the margin of peak level.
- 25 SKIP PLAY button**
Press to activate the skip ID code function. The portion of the tape previously marked will be skipped.
- 26 CD operation buttons**
Operative only for the Sony CD player equipped with a remote commander.
|| (pause): Press this button twice to start playback. To enter the pause mode, press this button once.
⏪ (AMS): Press to locate the desired selection on the Compact Disc during playback or in the stop mode.
- 27 CD SYNCHRO (CD synchronized recording) buttons**
(The playback of the Sony CD player equipped with a remote commander and the recording of the DAT deck can be performed simultaneously.)
STANDBY: Press to set the unit to the record-standby mode.
START: Press to start recording of the DAT deck and then playback of the CD player.
STOP: Press to stop the DAT deck recording and the CD player playback.

Connections

This section describes about the connecting cords and the analog and digital connections. Select the connection depending on your equipment connected with this unit.

Rear Panel Jacks

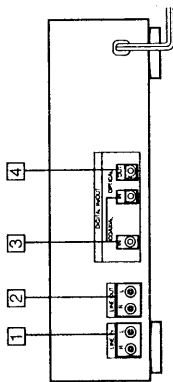

- 1 LINE IN (line input) jacks (phono jack)**
Connect to the recording outputs of an amplifier. Signals supplied by the amplifier can be recorded using the sampling frequency of 48 kHz in the standard play mode or 32 kHz in the long play mode.
- 2 LINE OUT (line output) jacks (phono jack)**
Connect to the DAT or tape inputs of an amplifier. The playback signal of this deck will be output.
- 3 COAXIAL/OPTICAL DIGITAL IN (digital input) jacks (coaxial phono jack/optical jack)**
Connect to the digital outputs of an amplifier having a built-in D/A converter or other digital source, such as a CD player for digital-to-digital recording.
- 4 OPTICAL DIGITAL OUT (digital output) jack (optical jack)**
Connect to the digital inputs of an amplifier having a built-in D/A converter or another DAT deck, for playback of a DAT cassette or digital-to-digital recording.

Notes on connection

- Use the connecting cords specified in the illustrations.
- Turn off the power for all equipments before making connections.
- Be sure to insert the plugs firmly into the jacks. Loose connections may cause hum and noise. When unplugging, grasp the plug and not the cord.

- Notes on the optical cable**
 - Do not bend the cord. When the cord is not used, curl it with a diameter of more than 15 cm (5 7/8 inches).
 - Do not use it under high temperatures.
 - When the optical cable is not connected, cover the OPTICAL IN/OUT jacks with the supplied caps.

Note on sound signals

When connecting an optical cable to the DIGITAL IN/ DIGITAL OUT jacks, sound signals (L/R) are transmitted together through the cable.

Connecting Cords

There are following three types of connecting jacks at the rear of the deck. Each type of jack requires a different type of connecting cord.

The LINE IN/OUT (analog input/output) jacks

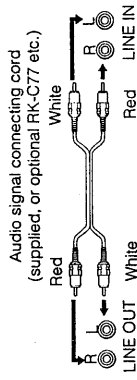

The COAXIAL IN (digital input) jack

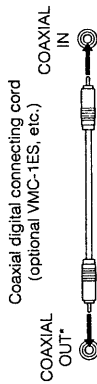

* This unit is not equipped with the COAXIAL OUT jack.

The OPTICAL IN/OUT (optical transmission digital input/output) jacks

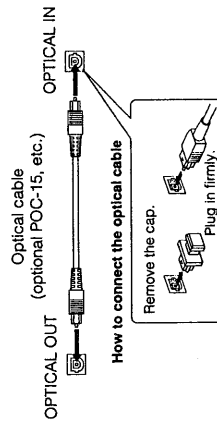

Identifying Parts and Controls

Display Window

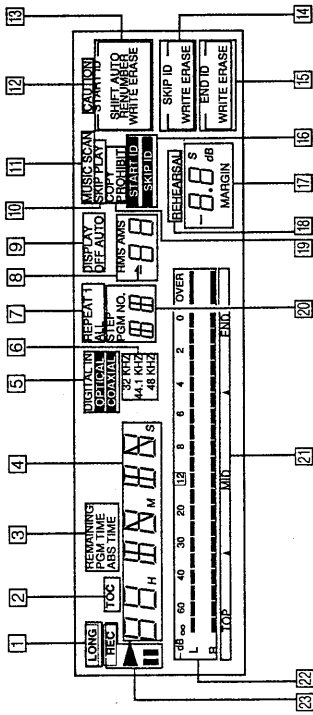

The following functions can be performed only with the remote commander.

To turn off the display window

When the power is turned on, the display window is also turned on. During recording or playback, all display or some parts of the display can be turned off. Each time you press the DISPLAY MODE button, the indicators change as follows.

- Normal indicators
- Peak level meters and margin indicators go off. (The DISPLAY OFF indicator lights.)
- All the indicators go off during recording or playback*. (The DISPLAY OFF AUTO indicator lights momentarily just before the indicators go off.)

* When pressing the DISPLAY MODE button except during recording or playback, the DISPLAY OFF AUTO indicator lights. In this case, all the indicators go off immediately after recording or playback starts.

To change the brightness of the display window

While pressing the COUNTER MODE button, press one of the numeric buttons 1, 2 and 3. The greater number pressed, the darker the display window becomes.

- 1 **LONG play mode indicator**
Lights when recording or playback is being performed in the long play mode.

- 2 **TOC (Table Of Contents) indicator**
When a pre-recorded DAT cassette is played back, this indicator will light.

- 3 **REMAINING (remaining time):** Lights when the counter shows the remaining time of the tape.
- 4 **PGM TIME (program time):** Lights when the counter shows the elapsed time of the current selection.
- 5 **ABS TIME (absolute time) indicator:** Lights when the counter shows the elapsed time from the beginning of the tape.

- 6 **Time indicator**
Indicates the tape running time, absolute time, elapsed time of the current selection or remaining time. Each time the COUNTER MODE button is pressed, the display is changed.

- 7 **INPUT selector indicators**
The OPTICAL or COAXIAL indicator lights according to the position of the INPUT selector. No indicator lights when the INPUT selector is set to the ANALOG position.

- 8 **Sampling frequency indicator**
48 kHz: For recording/playback of analog input signals (standard mode)
44.1 kHz: For recording/playback of CD or a pre-recorded DAT cassette
32 kHz: For recording/playback of analog input signals (long-play mode)

- 7 **REPEAT indicators**
REPEAT 1: Lights when a desired selection is played back repeatedly.
REPEAT ALL: Lights when all the selections are played back repeatedly.

- 8 **AMS (Automatic Music Sensor)/RMS (Random Music Sensor) indicators**
Show the number of selections to be skipped ahead or behind in the AMS operation. When designating a selection directly by the numeric button and the \blacktriangleright button, the display shows the program number of the target selection while the selection is being searched for. When programming the desired selections in the RMS operation (page 33), the display shows the program number of the selection to be programmed.

- 9 **DISPLAY OFF/AUTO indicators**
The DISPLAY OFF indicator lights when peak level meters and margin indicators are turned off. The DISPLAY OFF AUTO indicator lights momentarily before all the indicators are turned off.

- 10 **SKIP PLAY indicator**
When this indicator is lit during playback, the portion marked by the skip ID is skipped and playback continues from the next start ID.

- 11 **MUSIC SCAN indicator**
Lights after pressing the MUSIC SCAN button to listen to the beginning of each selection successively.

- 12 **CAUTION indicator**
Lights when moisture condensation occurs. If this happens, the deck stops functioning automatically. (See page 3.)

- 13 **START ID mode indicators**
AUTO: Lights when the AUTO button is pressed to write the start ID automatically.
RENUMBER: Lights when the RENUMBER button is pressed to renumber the program numbers.

- 14 **WRITE ERASE:** Lights when writing the start ID manually.
AUTO RENUMBER: Lights when renumbering program numbers automatically.
SHIFT RENUMBER: Lights when shifting the start ID and program number position.

- 15 **SKIP ID mode indicator**
WRITE: Lights when writing the skip ID.
ERASE: Lights when erasing the skip ID.

- 16 **END ID mode indicator**
WRITE: Lights when writing the end ID.
ERASE: Lights when erasing the end ID.

- 17 **START ID indicator:** Flashes when writing (for 9 or 18 seconds), erasing a start ID code, and lights when the start ID is detected during playback.
SKIP ID indicator: Lights when writing (for 1 or 2 seconds) or erasing a skip ID code or when the skip ID is detected during playback.

- 18 **MARGIN indicator**
Shows how much margin there is between the peak level of input audio signal and 0 dB.

- 19 **REHEARSAL indicator**
Lights while the rehearsal function is activated (page 23).

- 20 **COPY PROHIBIT indicator**
Lights when recording the digital signal with the copy prohibit code. In this case, record with the LINE IN jacks.

- 21 **STEP/PGM NO. indicator**
Shows the program number of the selection being played. When programming the desired selection in the RMS operation (page 33), the display shows the step number of the programmed selection.

- 22 **Frequencies map**
When pressing the 4 button while keeping the COUNTER MODE button pressed, bars indicating the sampling frequencies with which the tape was recorded appear on the peak level meters.

- 23 **Peak level meters**
Indicate the level of the audio signal being recorded during recording, and the peak values of the audio signal recorded on the tape during playback.

- 24 **Tape operation indicators**
REC: Lights during recording or in the record-pause mode.
 \blacktriangleright : Lights during recording or playback. It also lights in the record-pause mode or in the play-pause mode.
II: Lights in the record-pause mode or in the play-pause mode.

SECTION 2 DISASSEMBLY

- Remove the following devices shown by ❶, etc. In the order of the numbers.

<p>[CASE]</p> <p>Unscrew the four case attachment screws and remove the case.</p>	<p>[CASSETTE WINDOW]</p> <ol style="list-style-type: none"> ❶ Press the OPEN/CLOSE switch to effect LOADING OUT STATE (if power is not supplied) rotate the pulley in the left side of the Mechanism Deck counterclockwise.) ❷ Remove the cassette by lifting the window up.
--	---

MECHANISM SECTION

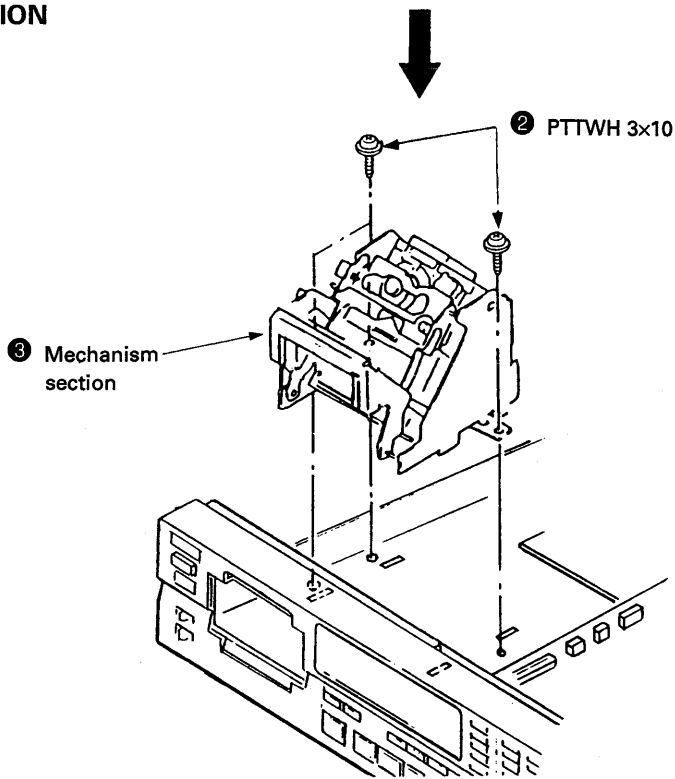

HOLDER

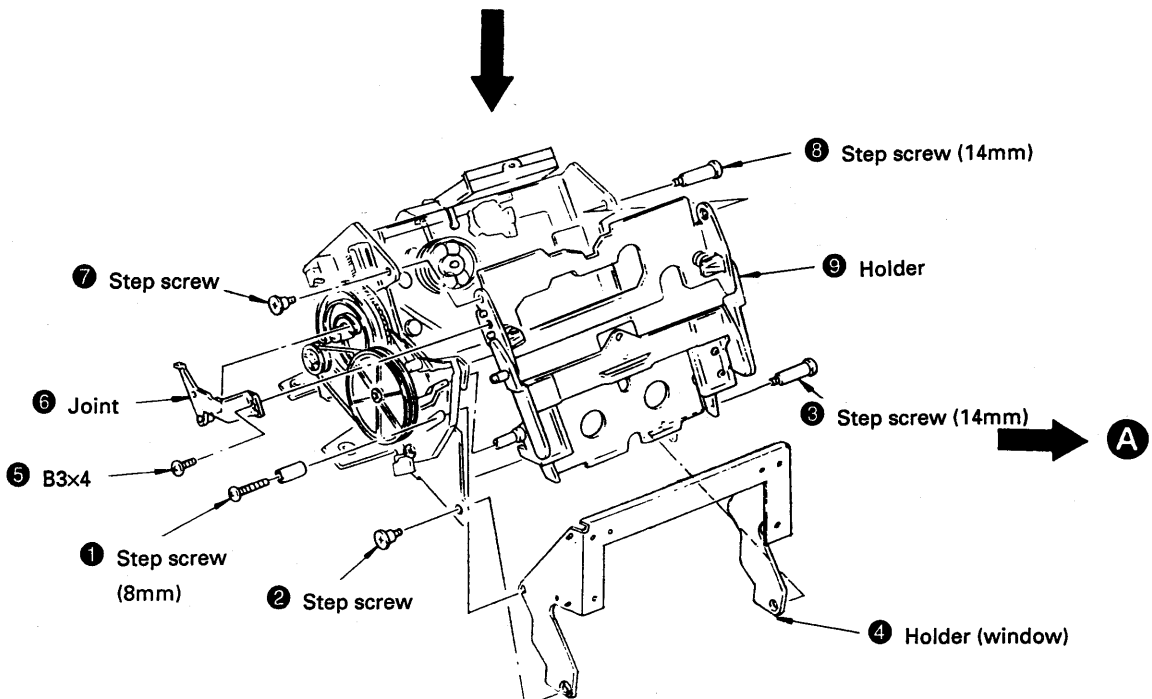

CASSETTE COMPARTMENT MOTOR (M901), PULLEY, GEAR (CAM) AND SLIDER

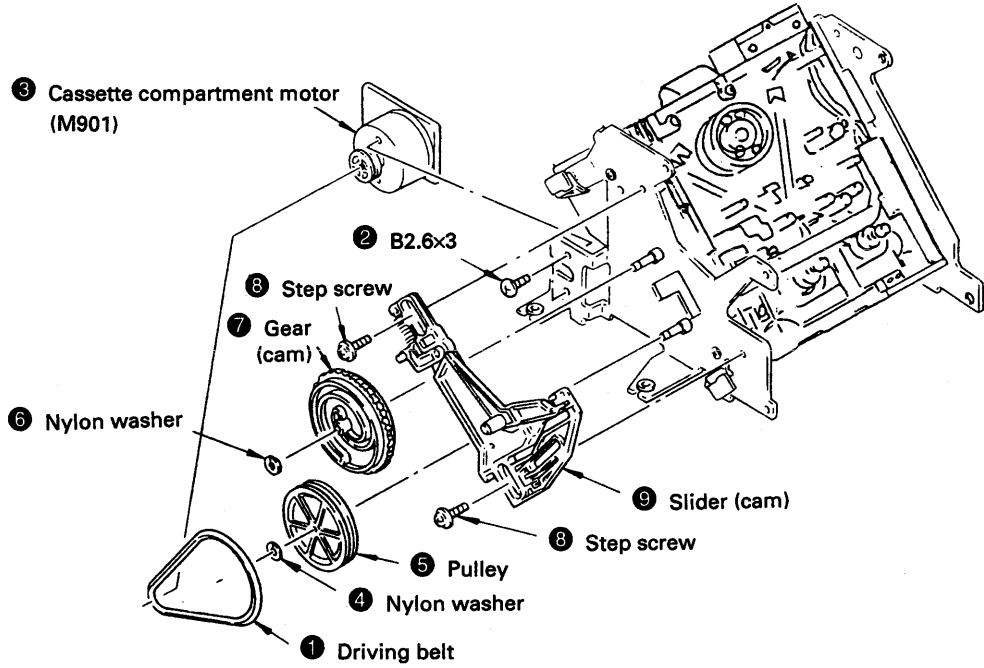

A

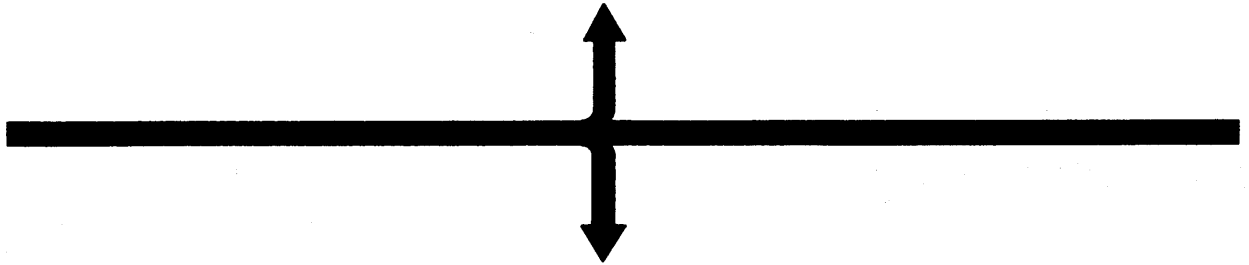

DRUM

- 1 Remove the drum lead wires on rear side of the drum from the connector.

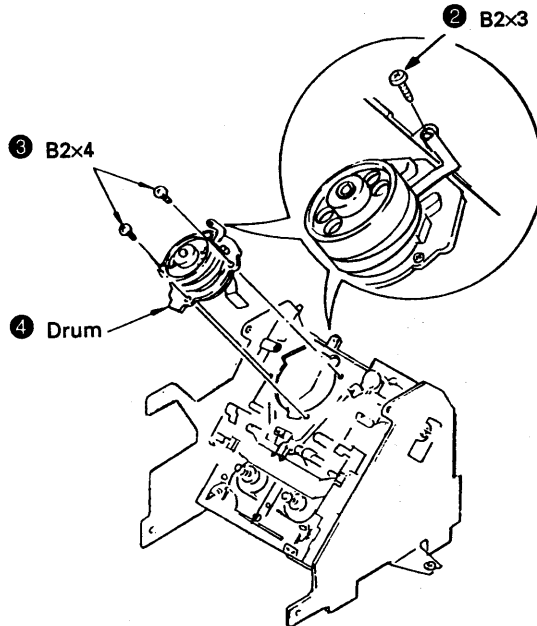

DRUM DRIVE BOARD, DRIVING CHASSIS

1 Remove the connector on the drum drive board.

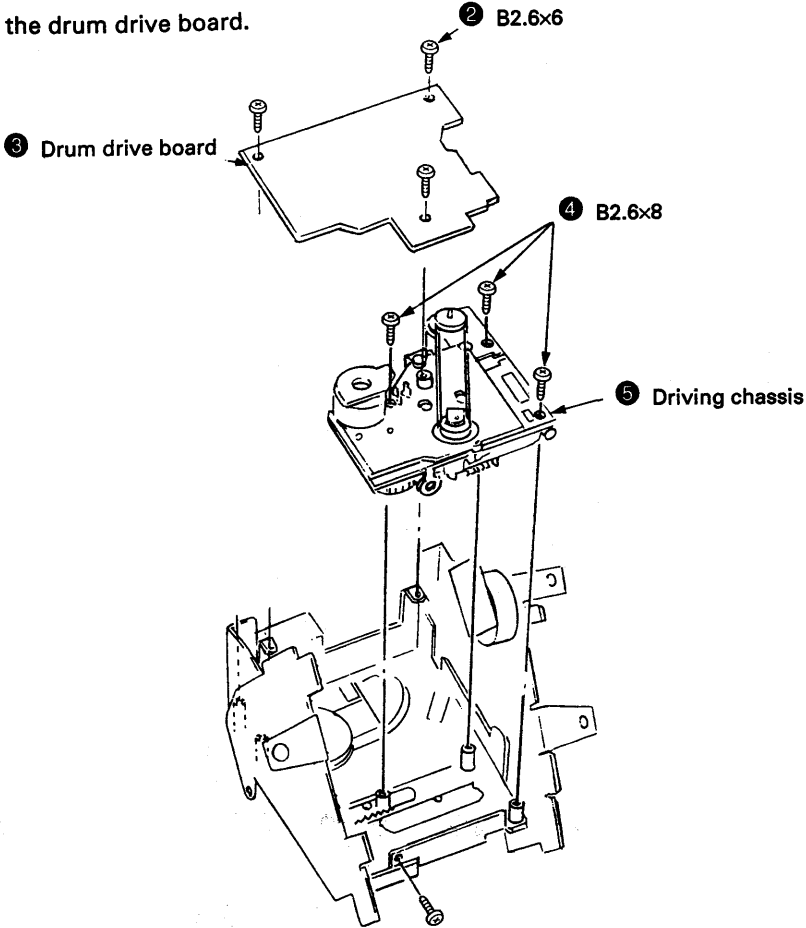

CAPSTAN MOTOR (M902)

1 Precision screw M1.7x4

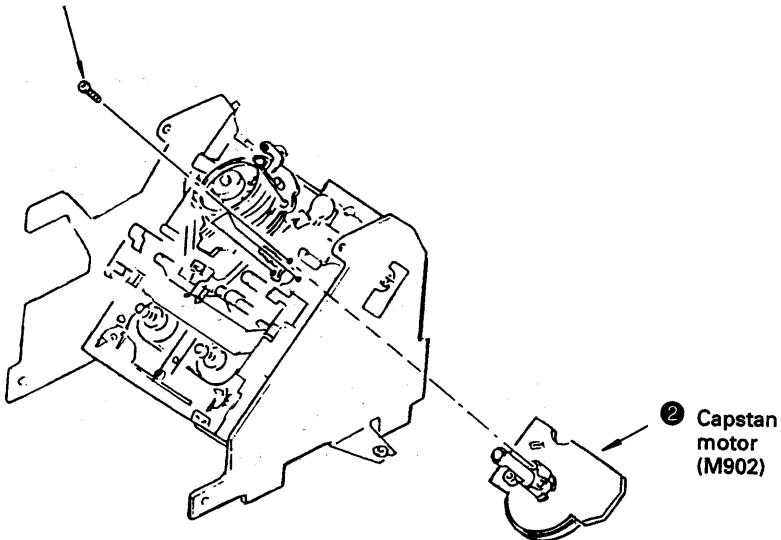

SECTION 3 ADJUSTMENTS

Notes When Making Adjustments

1. Adjustments should be performed in the order listed.
2. Use the following test tapes :

TY-7111 (8-909-812-00)	Level
TY-7252 (8-909-822-00)	Tracking
TY-7551 (8-909-814-00)	Functions
TY-30B (8-892-358-00)	Blank
- Use the following torque meter:

TW-7131 (8-909-708-71)	FWD
------------------------------	-----
3. Switches and controls should be set as follows unless otherwise specified.

TIMER switch	: OFF
REC MODE switch	: LONG
INPUT switch	: COAXIAL
REC LEVEL control	: Min.
PHONES LEVEL control	: Min.
4. Creating an end sensor cassette

- (1) Press the tape slider lock and move the slider in the direction indicated by the arrow.

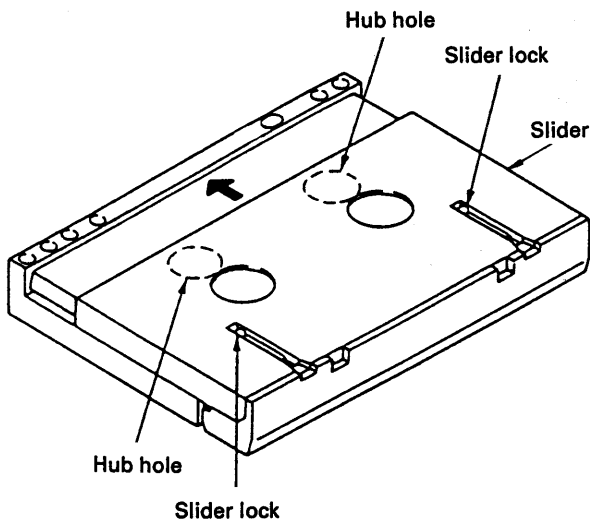

- (2) Open the lid and cut the tape.

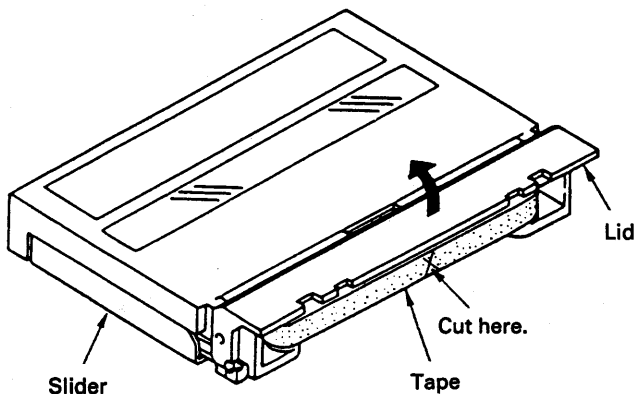

- (3) Turn the hubs until the tape is completely inside the cassette (both T and S sides).
The end sensor cassette for end sensor adjustment is now ready for use.

5. Cleaning of the Revolving Drum
 - (1) Fold a chamois (2-034-697-00) or a knit cloth into 4 or more files, slightly impregnate it with a cleaning liquid (9-919-573-00), and softly touch the drum with it and manually rotate the drum slowly counterclockwise by 2 to 3 turns for cleaning.
 - (2) At that time, be careful not to move the chamois vertically to the head tip. Otherwise, the head tip may probably be damaged.
6. Be careful not to move RV1 and RV2 on the RF AMP board in the mechanism assembly.
7. To adjust the tape path and guides, remove the holder assembly as shown in the diagram and use the DAT holder jig (J-8000-002-A). This will make it easier to perform adjustments.
 - First turning the pulley counterclockwise to put it in loading out status will make removal and reattachment of the holder assembly easier.
 - To perform adjustments, turn the pulley clockwise to put it in loading in status, load the cassette tape and set the IN switch to the ON position.

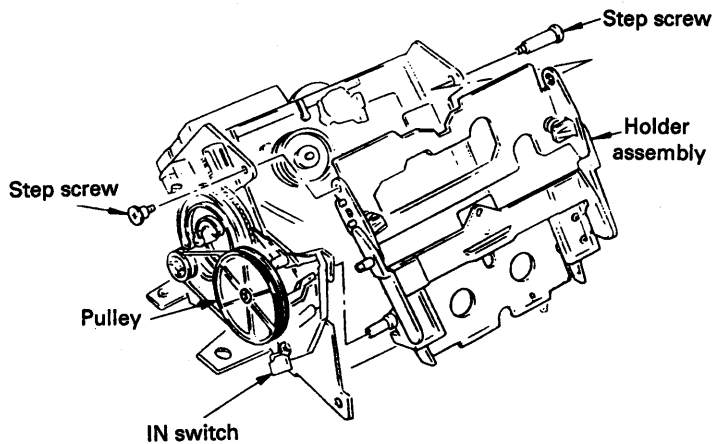

8. Test mode

The test mode is effected by shorting TP (XTEST MAIN, XTEST SERVO and XTEST DISP) on the main board and the control switch board and GND.

 - (1) Test mode (main - servo)

Turn OFF the power switch, connect XTEST MAIN and XTEST SERVO on the main board to GND and perform the following adjustments.

 - Tape path fine adjustment
 - DPG adjustment
 - ATF pilot (GCA) checking
 - End sensor checking
 - FWD torque checking
 - FWD back tension checking and adjustment
 - (2) Test mode (display)

You can check the following FL display tube and the panel switch by turning OFF the power switch, disconnecting CN932 on the power board, removing flexible board CN752 on the control switch board, connecting XTEST DISP to GND, connecting CN932 again and then turning ON the power switch.

Each grid of the FL display tube sequentially lights up while all tubes being lighted up finally.



Level meters go out one after one.



Press any of the remote controller for DAT in this state. Thus, all level meters go out. (It may sometimes occur that one or two meters remain lighting up according to switch setting at that time.)



Everytime a switch on the panel is pressed, display tubes light up sequentially one after one. With all keys once pressed, all level meters go out.

- To reset the test mode, disconnect the wire shorting XTEST and GND. After completion of adjusting, be sure to reset the test mode.

9. Check the following items for correct tape speed, after completion of adjusting.

- (1) Set the REC MODE switch to STANDARD and check for normal recording and playback. (× 1)
- (2) Set the REC MODE switch to LONG and check for normal recording and playback. (× 0.5)
- (3) With QUE (▶ + ▶▶) or REVIEW (▶ + ◀◀), check that qurrr, qurrr sound is heard. (× 3, × 8)
- (4) Check that correct time is displayed after FF (▶▶) or REV (◀◀). (× 16)
- (5) Check that SEARCH (▶◀, ◀▶) is normal.

Adjust Parts Location

— Mechanism assembly —

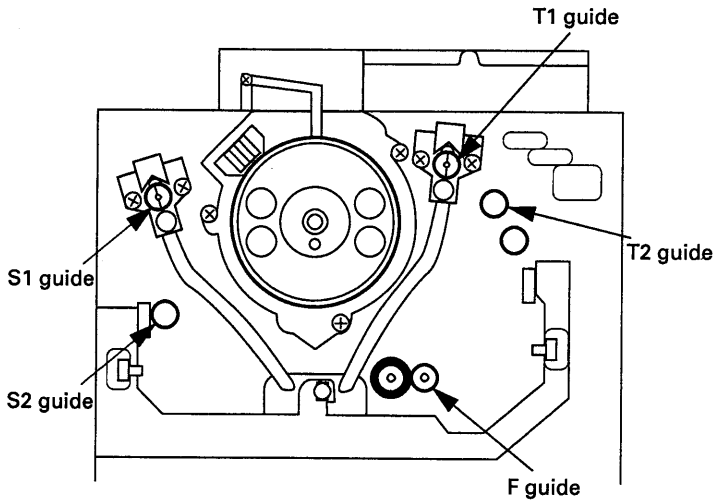

— Control sw board —

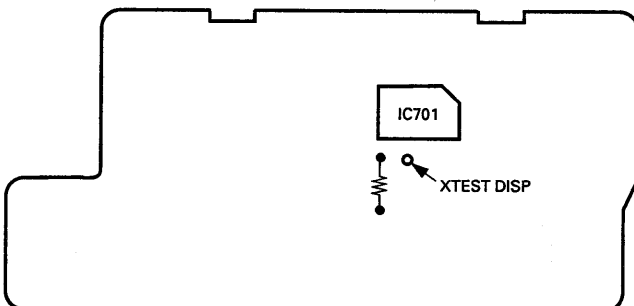

— Main board —
(Component side)

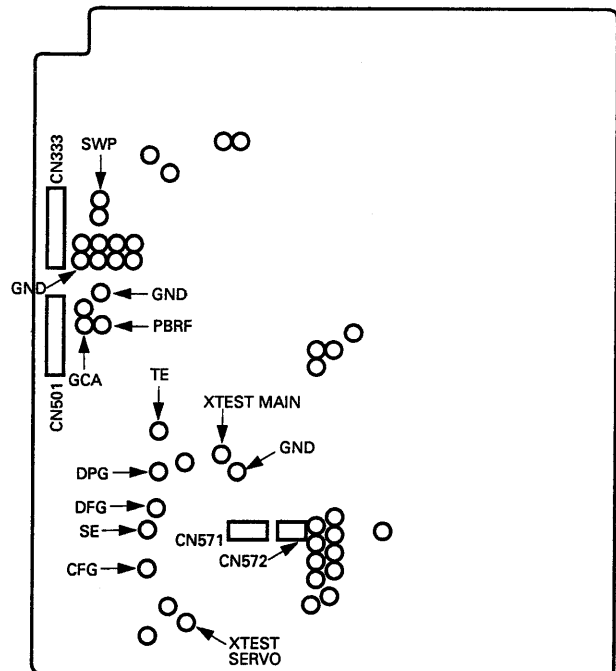

3-1. ELECTRICAL ADJUSTMENTS

End Sensor Check

Perform the following adjustment when the holder has been removed or part of the mechanism deck section replaced.

Check Procedure:

1. Connect an oscilloscope to the test land SE (in the S side) and TE (in the T side) of the main board.
2. Actuate the test mode (main · servo), mount an end sensor cassette and effect the STOP (■) mode.
3. Check that p-p values of waveform of the oscilloscope satisfy the following.

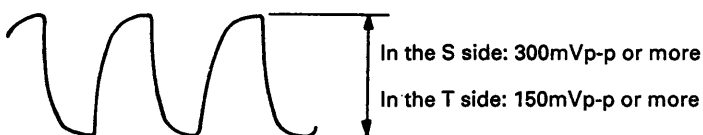

FWD Torque Check

Check Procedure:

1. Put the set into the test mode (main · servo) and load the FWD torque meter TW-7131 (8-909-708-71).
2. Put the set into the PLAY (▶) mode.
3. Confirm that the FWD torque value (take-up side rewinding torque) is between 10 – 20 g·cm (0.14 – 0.28 oz·inch).
4. Confirm that the value indicated by the torque meter is maintained for one full cycle.

FWD Back Tension Check and Adjustment

Check procedure:

1. Put the set into the test mode (main · servo) and load the FWD torque meter TW-7131 (8-909-708-71)
2. Put the set into the PLAY (▶) mode.
3. Confirm that the back tension (supply side) is between 5 – 6 g·cm (0.07 – 0.09 oz·inch).

If this is not satisfied, adjust back tension by rotating the FWD back tension adjustment screw equipped on the side surface of the mechanical deck. After completion of adjusting, be sure to apply screw lock.

4. Confirm that value indicated by the torque meter is maintained for one full cycle.

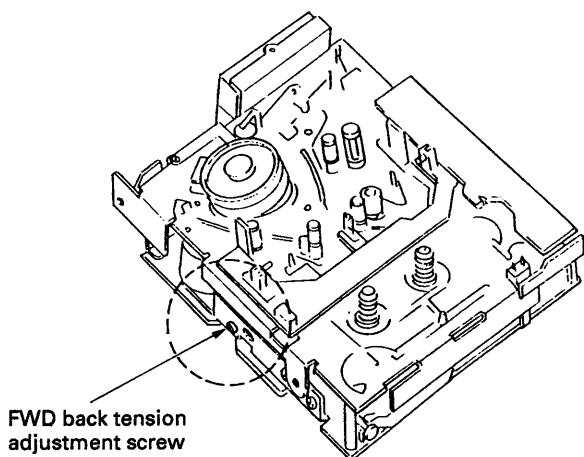

To tighten (clockwise) — back tension becomes larger.
To loosen (counterclockwise) — back tension becomes smaller.

Tape Path Fine Adjustments (× 1.5 FWD Mode)

Perform the following adjustment when the drum has been replaced.

Adjustment Procedure :

1. Connect an oscilloscope CH-1 to TP (PBRF) and CH-2 to TP (SWP) on the main board.
2. Put the set into the test mode (main · servo) and load test tape TY-7252 (8-909-822-00).
3. Press the AMS (▶▶) key.
Each part of switches on Test Mode.

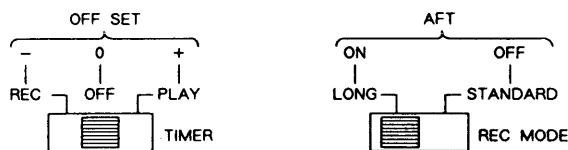

4. With the REC MODE switch set to STANDARD (ATF: OFF) and the TIMER switch set to PLAY or REC (OFFSET: + or -), fine adjust the S1 and T1 guides so that the oscilloscope RF signal waveform remains the same when high-low is repeated.

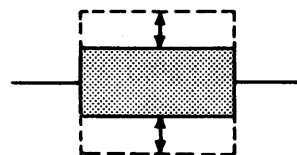

* Finish the adjustment by screwing in.

5. Check the RF signal waveform with the REC MODE switch set to LONG (ATF: ON) and the TIMER switch set to PLAY or REC (OFFSET: + or -).

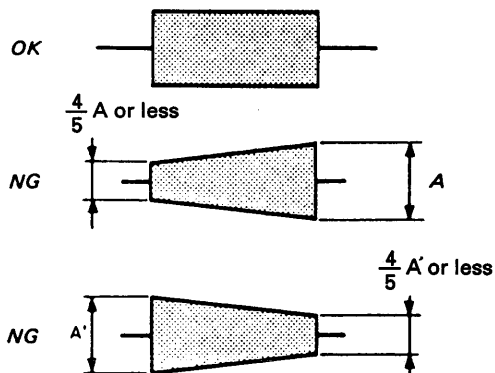

6. Check the RF signal waveform with the REC MODE switch set to LONG (ATF: ON) and the TIMER switch set to PLAY or REC (OFFSET: 0).
(1) Confirm that the RF signal waveform peak value (B) is 60 mV or more.

- Confirm that the undershoot level of the RF signal waveform's flat portion is within 10%.

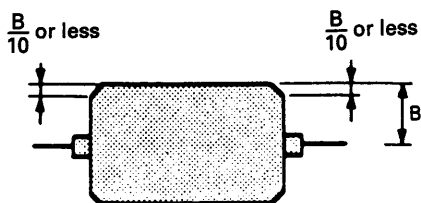

- When the measured values are not within the above tolerance, repeat items 3 – 6 above.

Adjustment Point: mechanism assembly

DPG Adjustment

Perform the following adjustment without fail when the drum has been replaced.

Adjustment Procedure:

- Connect oscilloscope CH-1 to TP (PBRF) and CH-2 to TP (SWP) on the main board. (Use CH-2 as the trigger. When the CH-2 signal is inverted, the trailing edge can be used for synchronization.)
- Put the set into the test mode (main · servo) and load test tape TY-7252 (8-909-822-00).
- Set the REC MODE switch to LONG (ATF: ON) and the TIMER switch to OFF (OFFSET: 0).
- Press the AMS (▶◀) key.
- Press the ◀◀ and ▶▶ keys as appropriate so that the gap between the oscilloscope SWP and RF signals becomes $650 \pm 15 \mu\text{sec}$. (Hold the ◀◀ and ▶▶ keys down for more than 1 second to perform rough adjustment. Hold them down for approximately 0.2 seconds for fine adjustment.)

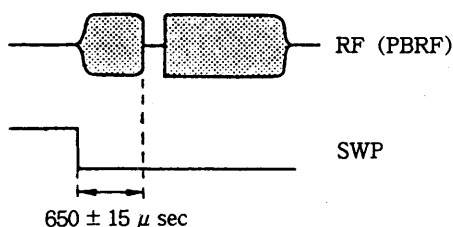

ATF Pilot (GCA) Check

Perform this adjustment after cleaning the heads with a cleaning cassette.

Check Procedure:

- Connect oscilloscope CH-1 to TP (GCA: Gain Control Amp.) and CH-2 to TP (SWP) on the main board. (When the CH-2 signal is inverted, the trailing edge can be used for synchronization.)
- Put the set into the test mode (main · servo) and load test tape TY-7111 (8-909-812-00).

- Actuate the PLAY (▶) mode and check that the GCA waveform on the oscilloscope is as follows.

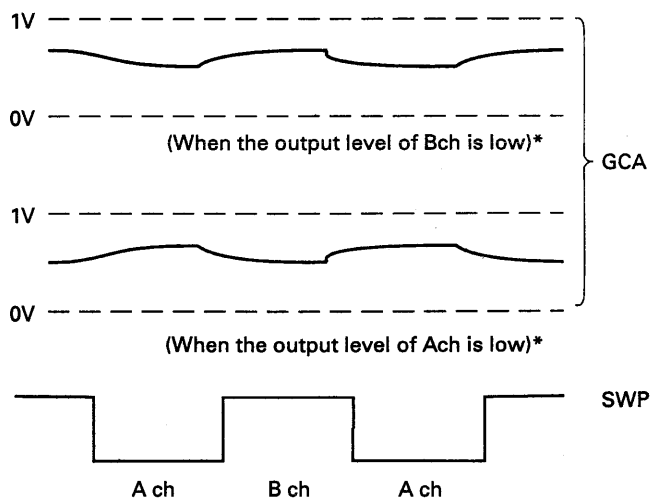

* Slightly changes depending on the state of the head. NG if the GCA waveform is 1V or more or equal to the GND level.

SECTION 4 DIAGRAMS

4-1. CIRCUIT BOARDS LOCATION

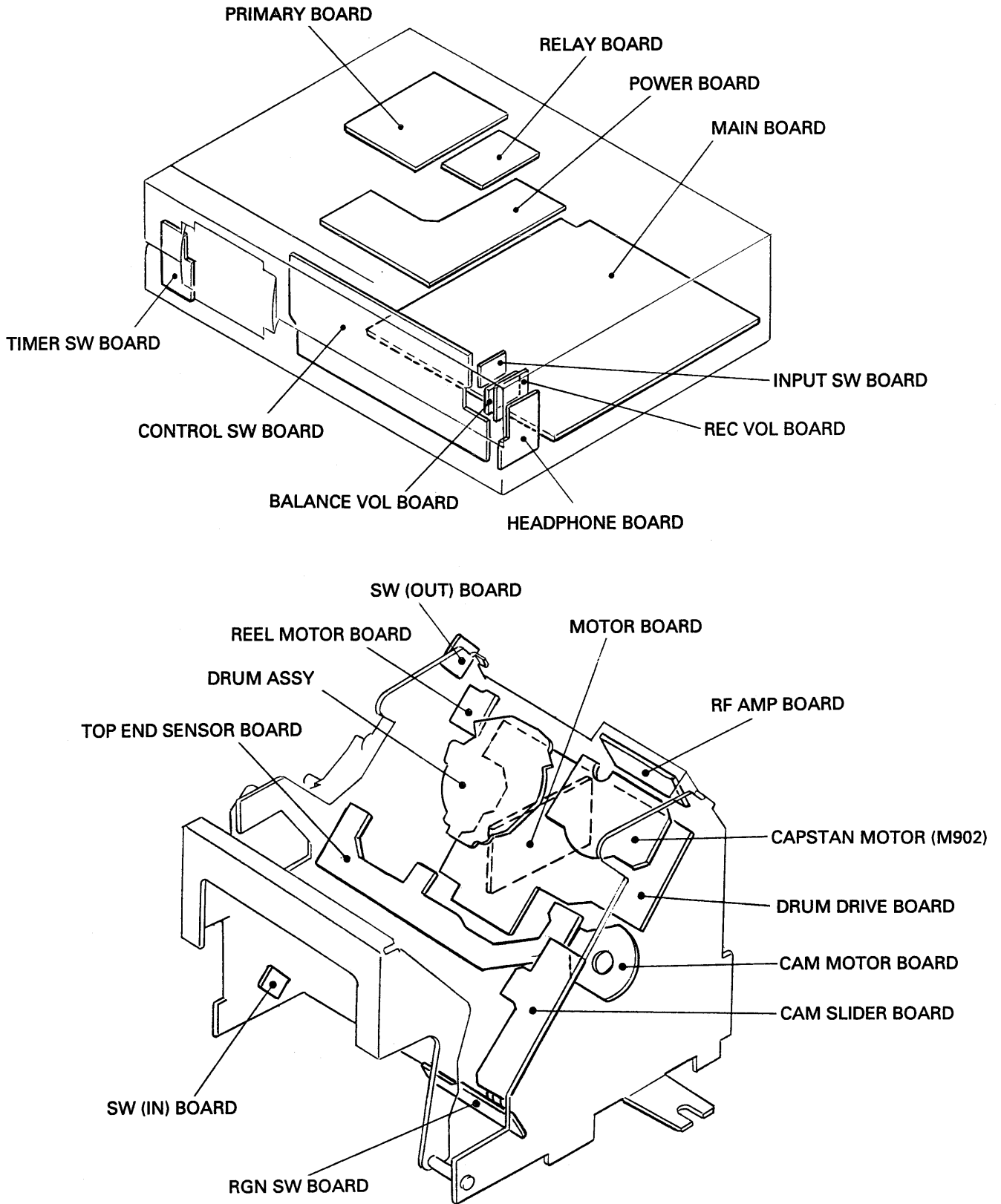

4-2. BLOCK DIAGRAM

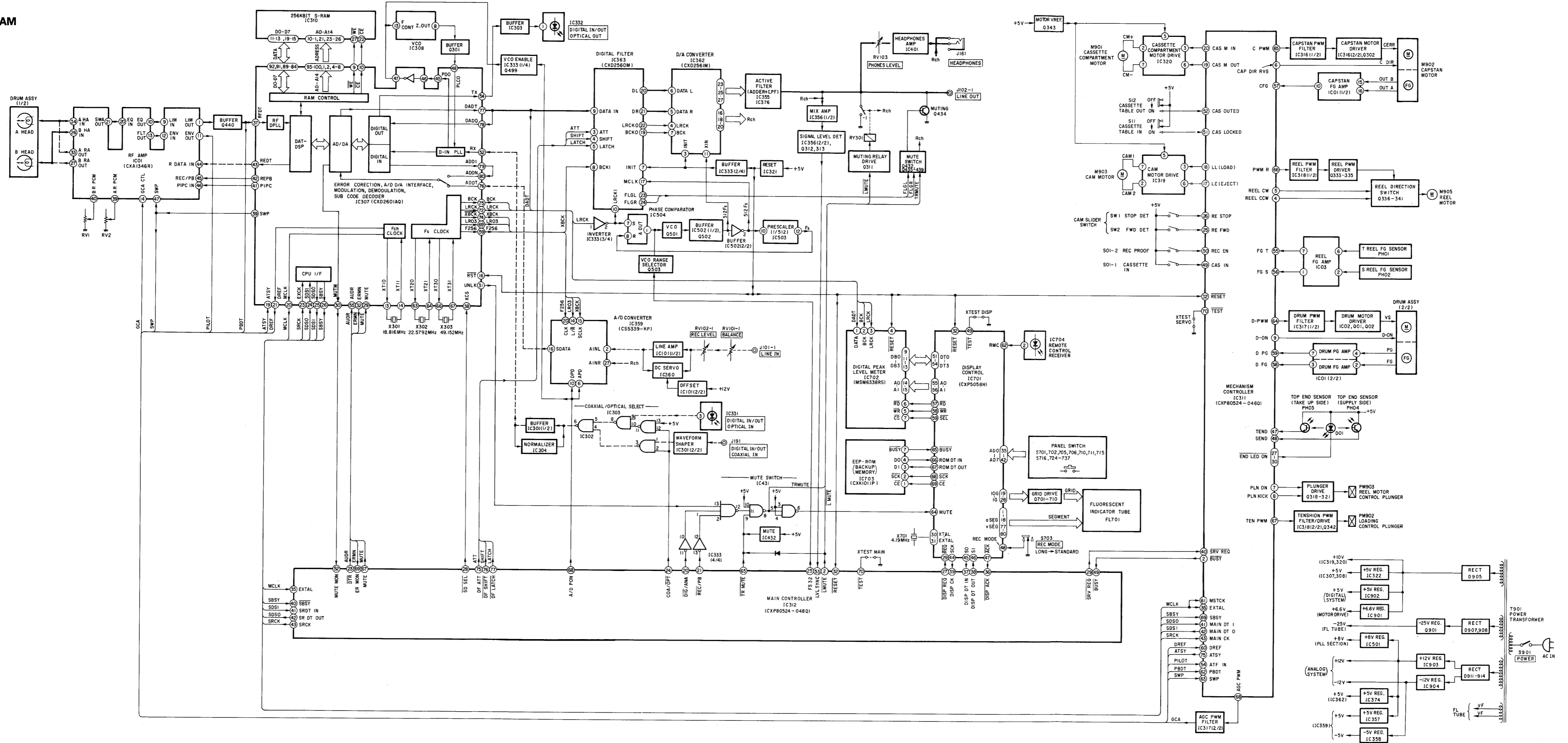

4-3. WAVEFORMS

① FL701 ①-②pin
(1G-10G)
32Vp-p, 2.5ms

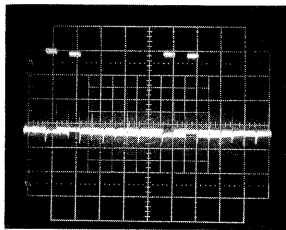

⑥ IC701 ④pin,
IC312 ③pin (SI)
5.2Vp-p, 0.64ms

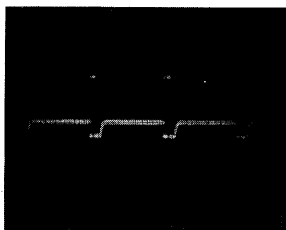

⑪ IC01 ①,⑦pin,IC311
⑤⑤,⑤⑥pin(FGT,FGS)
FF,REW mode
3.6Vp-p, 0.1ms

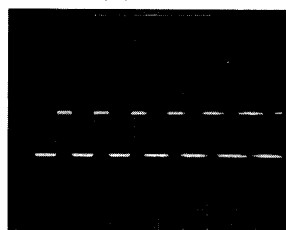

⑯ IC307 ⑦pin
(DADO)
5.2Vp-p, 5μs

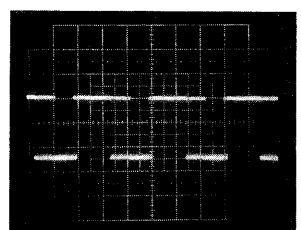

② IC701 ⑱-⑳pin
(10G-1G)
34Vp-p, 2.45ms

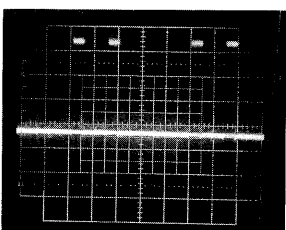

⑦ IC702 ①pin
(DATA)
6.4Vp-p, 0.3μs

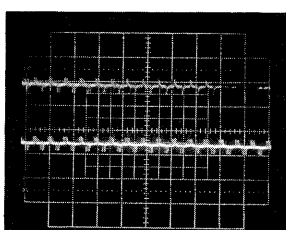

⑫ IC01 ⑩pin, IC311
⑤⑦pin (CFG)
PLAY mode
5Vp-p, 1.5ms

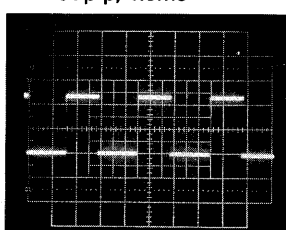

⑰ IC307 ⑦pin, IC359
⑩pin (ADDT)
REC mode
5.6Vp-p, 1μs

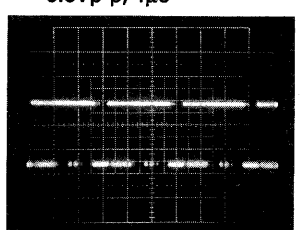

③ IC701 ⑦-⑩pin,
①-⑩pin (a-v)
38Vp-p, 1.2ms

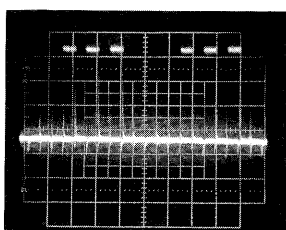

⑧ IC702 ②pin
(BCK)
5.2Vp-p, 0.3μs

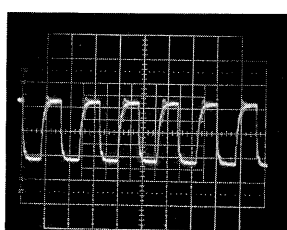

⑬ IC01 ⑦pin, IC311
⑤⑤pin (DPG)
PLAY mode
5Vp-p, 10ms

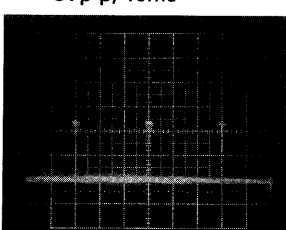

⑱ IC307 ⑤pin
(BCK)
5.2Vp-p, 0.3μs

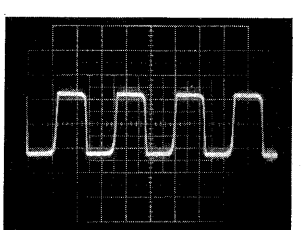

④ IC701 ③⑩pin
(XTAL)
5.5Vp-p, 2.5μs

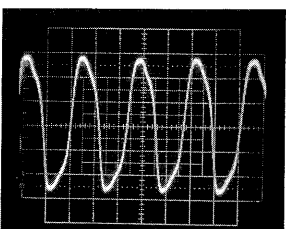

⑨ IC702 ③pin
(LRCK)
5.7Vp-p, 20μs

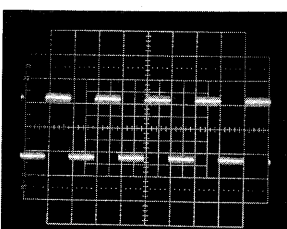

⑭ IC01 ③pin, IC311
⑤⑤pin (DFG)
PLAY mode
5Vp-p, 1.25ms

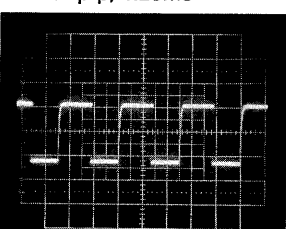

⑲ IC307 ④pin, IC359
⑤pin (XBCK)
6.4Vp-p, 0.48μs

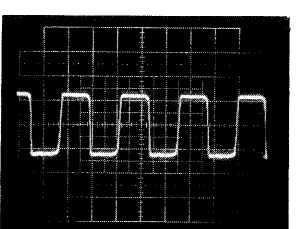

⑤ IC701 ③⑩pin
(EXTAL)
5Vp-p, 2.5μs

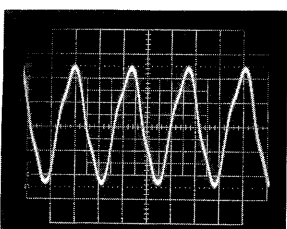

⑩ IC01 ②,③pin
(HEAD) REC mode
4.2Vp-p

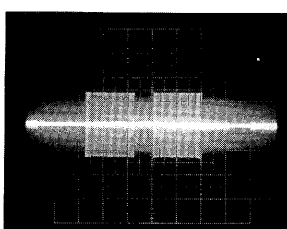

⑮ IC01 ①pin,Q440
Base (PBDT)
PLAY mode
1Vp-p

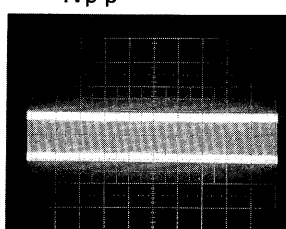

⑳ IC307 ②pin
(LRCK)
5.6Vp-p, 32μs

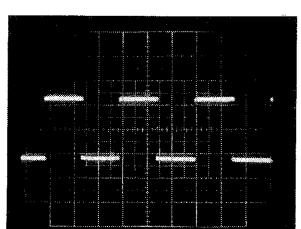

21 IC307 69pin, IC359
14pin (LR03)
5.6Vp-p, 32μs

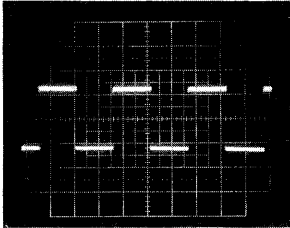

26 IC307 54pin
(TX)
PLAY mode
6.5Vp-p, 0.16μs

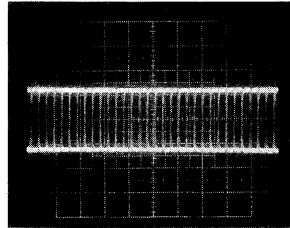

31 IC307 57pin, IC311
62pin (RFDT)
PLAY mode
1.3mVp-p, 2ms

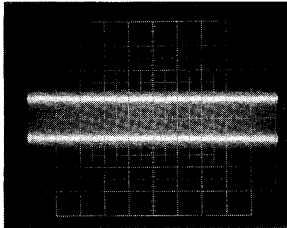

36 IC308 8pin
(ZOUT)
4.1Vp-p, 0.17μs

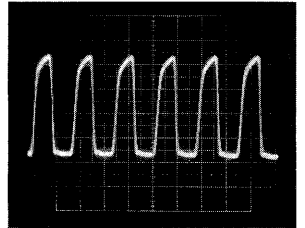

22 IC307 67pin
(XT3I)
0.9Vp-p, 0.2μs

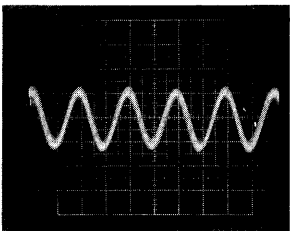

27 IC307 52pin
(RX)
5.2Vp-p, 0.1ms

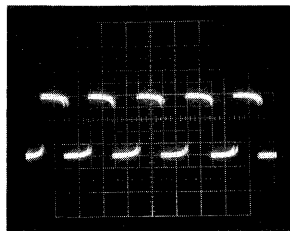

32 IC307 20pin, IC311
60pin (DREF)
6Vp-p, 1.75μs

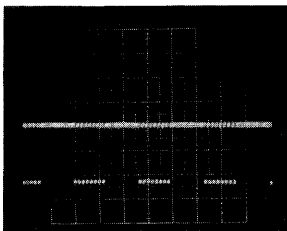

37 IC308 13pin
(F.C.)
25mVp-p, 0.17μs

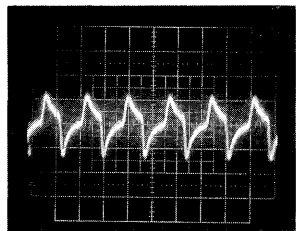

23 IC307 66pin
(XT3O)
2.9Vp-p, 0.2μs

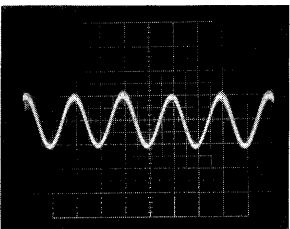

28 IC307 49pin
(PLCO)
4.8Vp-p, 0.18ms

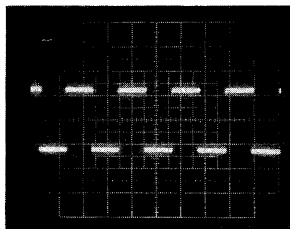

33 IC307 20pin, IC311
35 61pin IC312 35pin
(MCLK)
6Vp-p, 0.1μs

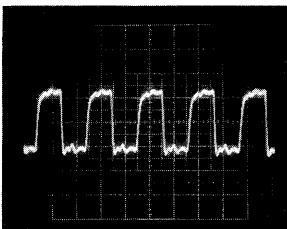

38 IC362 11pin, IC502
1, 6pin (XIN)
3.8Vp-p, 40ns

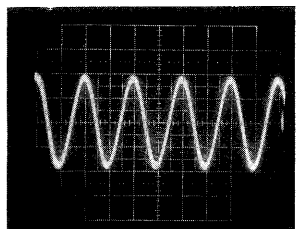

24 IC307 59pin
(F256)
6.1Vp-p, 85μs

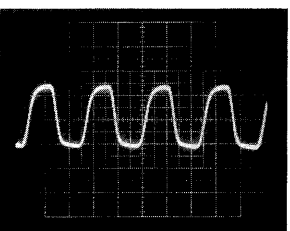

29 IC307 43pin
(REDT)
REC mode
4.4Vp-p, 0.84μs

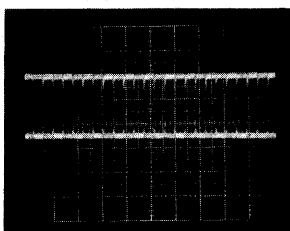

34 IC307 14pin
(XT1I)
2.8Vp-p, 55ns

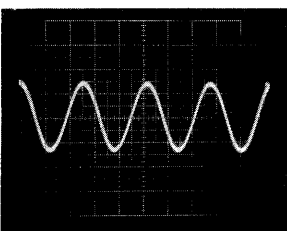

39 IC362 7pin
(BCK)
4.6Vp-p, 80ns

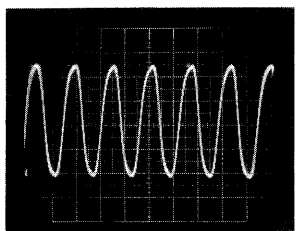

25 IC307 58pin
(F128)
6.8Vp-p, 0.17μs

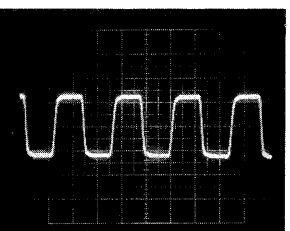

30 IC307 39pin, IC311
33pin (SWP)
PLAY mode
5.2Vp-p, 30ms

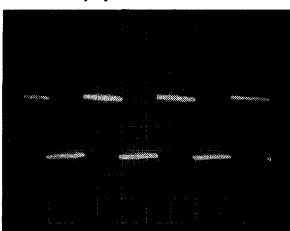

35 IC307 13pin
(XT10)
4.4Vp-p, 55ns

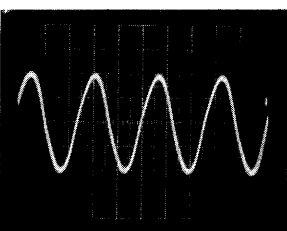

40 IC362 6, 5pin
(DATAL, DATAR)
5Vp-p

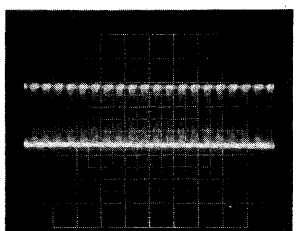

41 IC362 ④pin
(LRCK)
5Vp-p, 0.26μs

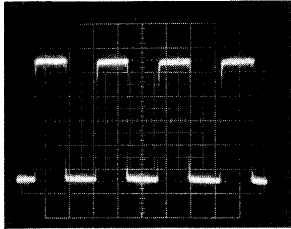

42 IC363 ⑰pin, IC503
⑩pin
(MCLK)
2.9Vp-p, 40ns

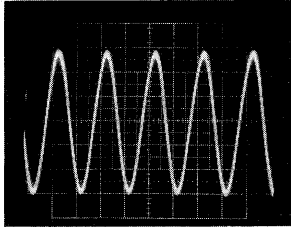

43 IC363 ⑩pin, IC504
⑦pin
(LRCKI)
5Vp-p, 21μs

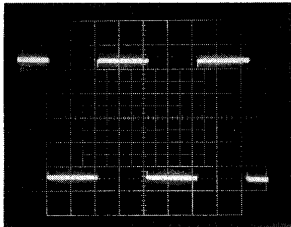

44 IC504 ⑧pin, IC503
⑫pin
(1/512)
4Vp-p, 20.5μs

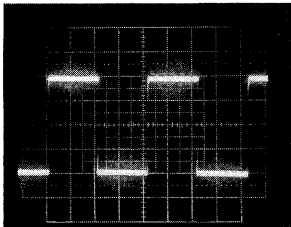

45 IC501 CATHODE
(VCO)
2.5Vp-p, 40ns

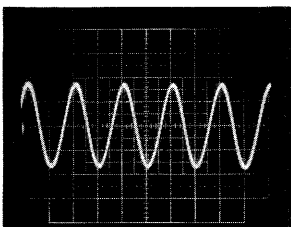

46 Q502 SOURCE
(VCO)
2.1Vp-p, 40ns

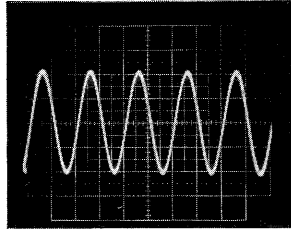

47 IC311 ⑥pin
(D PWM)
PLAYmode
5Vp-p, 0.14μs

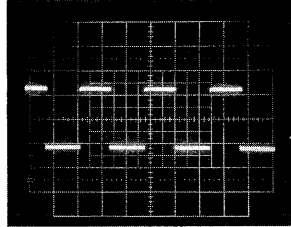

48 IC311 ⑤, ⑥pin
(CPWM, PWMR)
PLAY mode
5Vp-p, 28μs

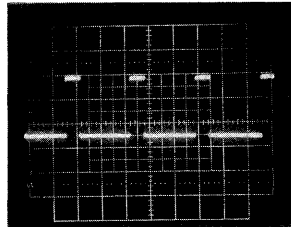

49 IC311 ⑦, ⑧pin
(TEN PWM, AGC
PWM) PLAY mode
5Vp-p, 28μs

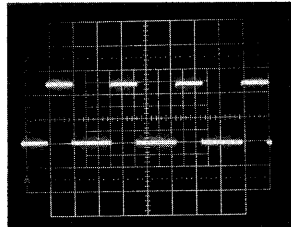

4-4. SEMICONDUCTOR LEAD LAYOUTS

AK5339

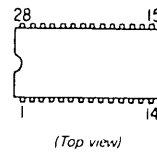

CX20115A
TC74HC4020AF

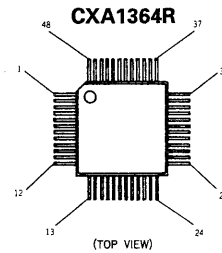
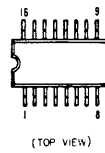

CXD2560M

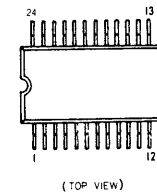

CXD2561M-1
CXK58257AM-12L

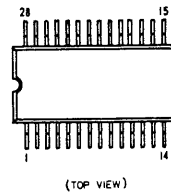

CXD2601AQ

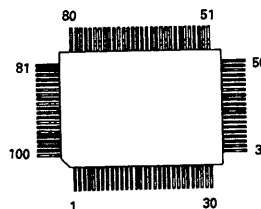

CXK1011P

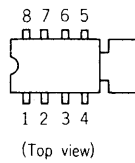

CXP5058H-657Q
CXP80524-046C
CXP80524-048Q

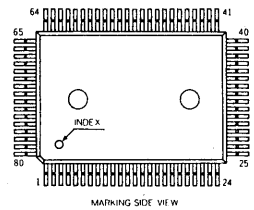

LF412CN/SL161841

M5238P
NE5532P
RC4558P
RC4560D-D
μPC358C

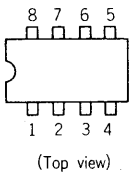

LM358M

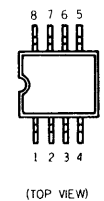

M54641L

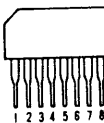

MSM6338RS

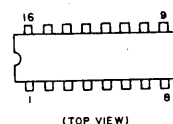

M5F7805L
M5F7805L-720
M5F7808
M5F7812L
μPC2406HF

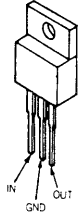

M5F7905L
TA7912S

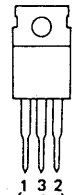

COMMON IN OUT
(GND)

PST529C
PST529E



SN74HCU04N
SN74LS624N
TC74HC00AP

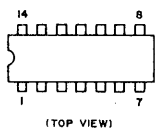

(TOP VIEW)

SN74HC10NS
TC74HCU04AF

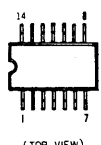

(TOP VIEW)

TC5081AP

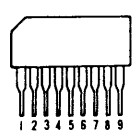

DTA114ES
DTC114ES

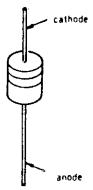

2SA933S-QR
2SD1387



2SA1585S-QR
2SC2785-HFE
2SC4115S-QR

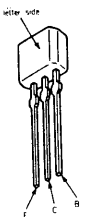

2SB734-34

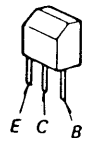

2SB798-DL

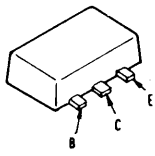

2SB1370-EF
2SD2012

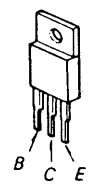

2SC1623

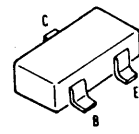

2SC3623A-K

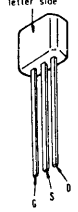

2SK241-GR

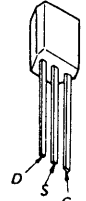

GL-453

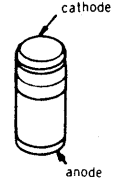

GP2S09-C

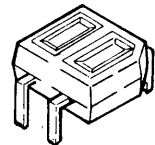

HZS6A1L
HZS24-3L
1SS168
1SS202-1
10E2N
11EQS04
11ES2

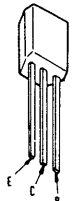

KV1310

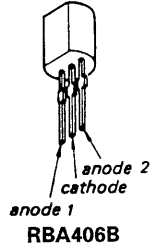

RBA406B

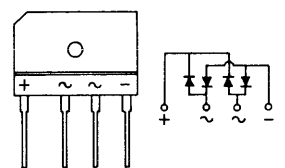

PT4850F

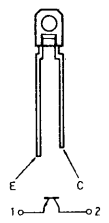

4-5. PRINTED WIRING BOARDS
 - MD/POWER SUPPLY/DISPLAY SECTION -

• See page 15 for circuit boards location and 22 for semiconductor lead layouts.

● SEMICONDUCTOR LOCATION

Ref. No.	Location	Ref. No.	Location
D01	G-23	IC902	G-9
D905	I-9		
D906	G-9	IC903	J-10
D907	I-9	IC904	J-10
D908	H-9		
D909	H-9	PH01	H-20
D910	H-9	PH02	H-20
D911	J-11	PH03	I-23
D912	K-11	PH04	F-23
D913	J-11		
D914	K-11	Q01	G-20
D915	K-9	Q02	G-20
D916	K-9	Q701	E-6
		Q702	E-7
		Q703	E-7
IC1	F-15		
IC01	F-19	Q704	E-7
IC02	F-20	Q705	E-7
IC03	H-21	Q706	E-7
IC701	E-5	Q707	E-7
		Q708	E-7
IC702	E-4		
IC703	E-4	Q709	E-7
IC704	E-2	Q710	E-8
IC901	G-9	Q901	H-9

Notes on printed wiring board:

- : Indicated a lead wire mounted on the component side
- : Parts mounted on the conductor side
- : Through hole
- ▨ : Pattern from the side which enables seeing
- ▩ : Pattern of the rear side

• G : Germany model

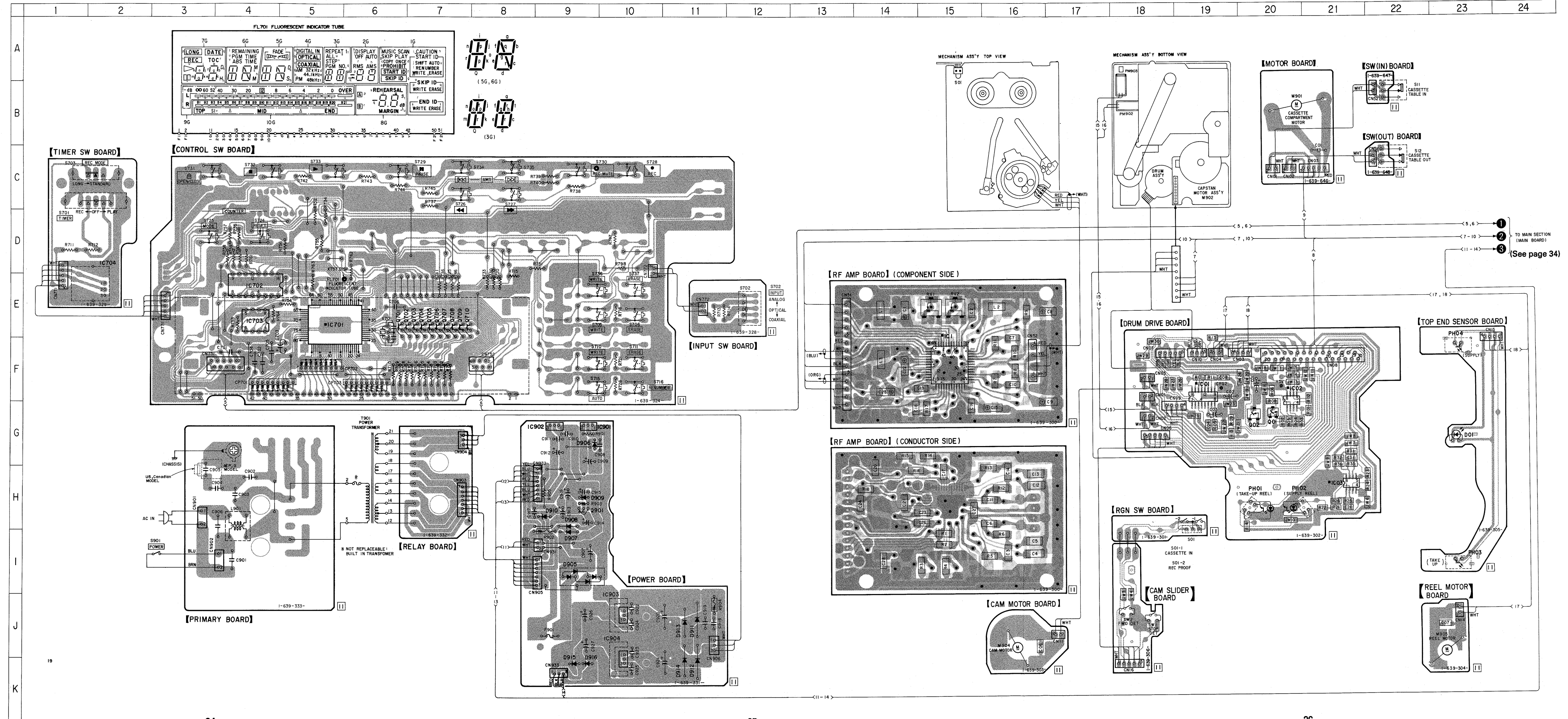

• See page 19 for waveforms, 39 for IC block diagrams and 43 for pin functions.

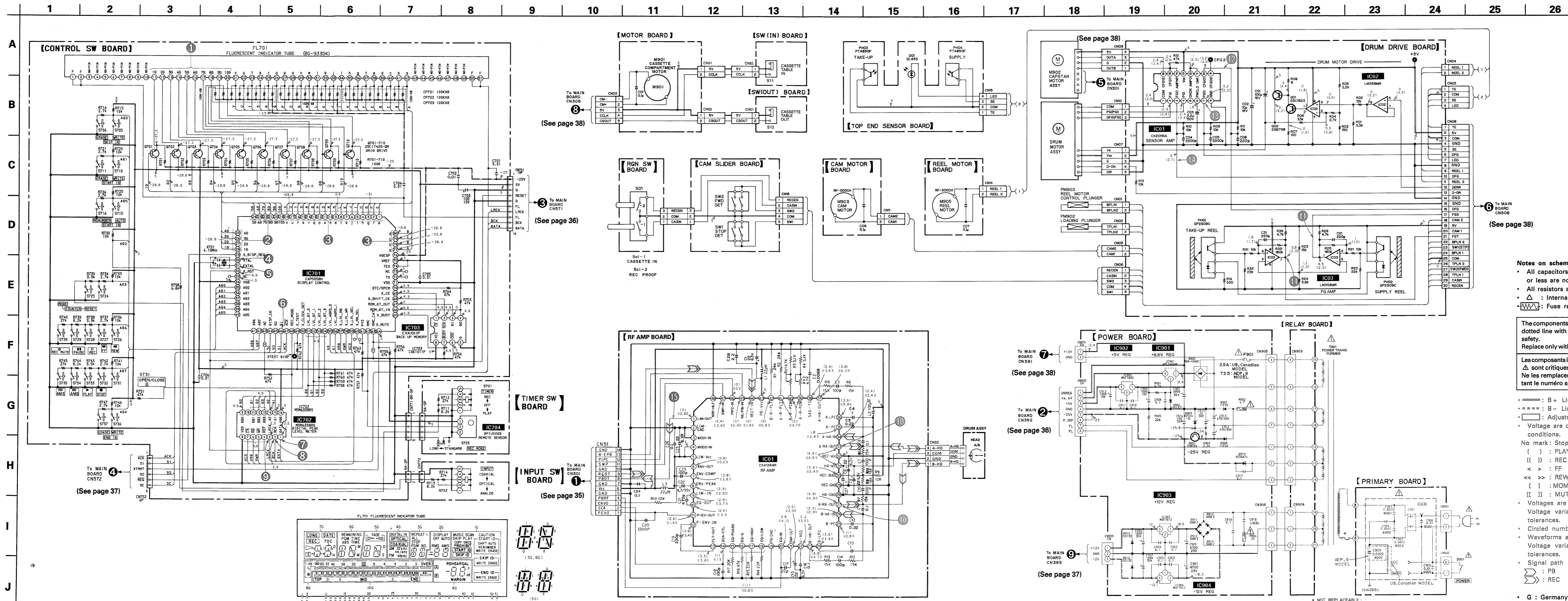

Notes on schematic diagram:
 • All capacitors are in μF unless otherwise noted. pF: μF 50WV or less are not indicated except for electrolytics and tantalums.
 • All resistors are in ohms, 1/4W or less unless otherwise noted.
 • Δ : Internal component
 • $\text{---}\text{---}\text{---}$: Fuse resistor

The components identified by mark Δ or dotted line with mark Δ are critical for safety.
 Les composants identifiés par une marque Δ sont critiques pour la sécurité.
 Ne les remplacer que par une pièce portant le numéro spécifié.

• $\text{---}\text{---}\text{---}$: B+ Line
 • $\text{---}\text{---}\text{---}$: B- Line
 • $\text{---}\text{---}\text{---}$: Adjustment for repair
 • Voltage are dc with respect to ground under no-signal (STOP) conditions.
 No mark: Stop
 (): PLAY
 (()): REC
 < > : FF
 << >> : REW
 [] : MOMENTARILY WHEN \triangleright , \triangleleft and \triangleright BUTTON IS PRESSED.
 [] : MUTING
 • Voltages are taken with a VOM (input impedance 10M Ω). Voltage variations may be noted due to normal production tolerances.
 • Circled numbers refer to waveforms.
 • Waveforms are taken with an oscilloscope. Voltage variations may be noted due to normal production tolerances.
 • Signal path
 $\text{---}\text{---}\text{---}$: PB
 • G : Germany model

4-7. PRINTED WIRING BOARDS - MAIN SECTION -

● SEMICONDUCTOR LOCATION

Ref. No.	Location	Ref. No.	Location
D101	F-4	IC363	C-7
D102	F-4	IC374	B-5
D201	E-4	IC375	F-6
D202	E-4	IC376	F-7
D306	F-10	IC401	F-2
D307	I-5	IC431	H-7
D308	H-6	IC432	I-7
D314	F-10	IC501	B-6
D323	F-11	IC502	B-6
D350	I-6	IC503	A-6
D401	F-2	IC504	B-8
D402	G-2		
D403	E-7		
D404	C-5	Q301	B-12
D501	C-7	Q302	I-9
D503	C-7	Q311	H-6
		Q312	I-5
		Q313	I-5
IC101	H-4		
IC201	H-4	Q318	F-10
IC301	B-8	Q319	F-10
IC302	B-10	Q320	F-10
IC303	B-11	Q321	F-10
		Q333	I-6
IC304	B-9		
IC307	D-10	Q334	I-6
IC308	C-11	Q335	I-6
IC310	D-11	Q336	J-11
IC311	I-10	Q337	J-10
		Q338	I-11
IC312	G-9		
IC316	J-9	Q339	I-11
IC317	J-7	Q340	I-11
IC318	J-6	Q341	J-11
IC319	F-11	Q342	I-7
		Q343	F-11
IC320	F-11		
IC321	G-7	Q432	H-6
IC322	E-9	Q433	G-5
IC331	A-10	Q434	G-6
IC332	A-11	Q435	H-6
		Q436	H-5
IC333	H-7		
IC354	E-6	Q437	H-5
IC355	E-7	Q438	H-6
IC356	I-4	Q439	H-5
IC357	C-4	Q440	E-11
		Q499	C-12
IC358	C-4		
IC359	D-4	Q501	B-7
IC360	F-4	Q502	B-7
IC362	C-6	Q503	C-6

Notes on printed wiring board:
 ○ : Indicated a lead wire mounted on the component side
 ■ : parts mounted on the conductor side
 ● : Through hole
 ◐ : Pattern from the side which enables seeing
 ◑ : Pattern of the rear side

• See page 15 for circuit boards location and 22 for semiconductor lead layouts.

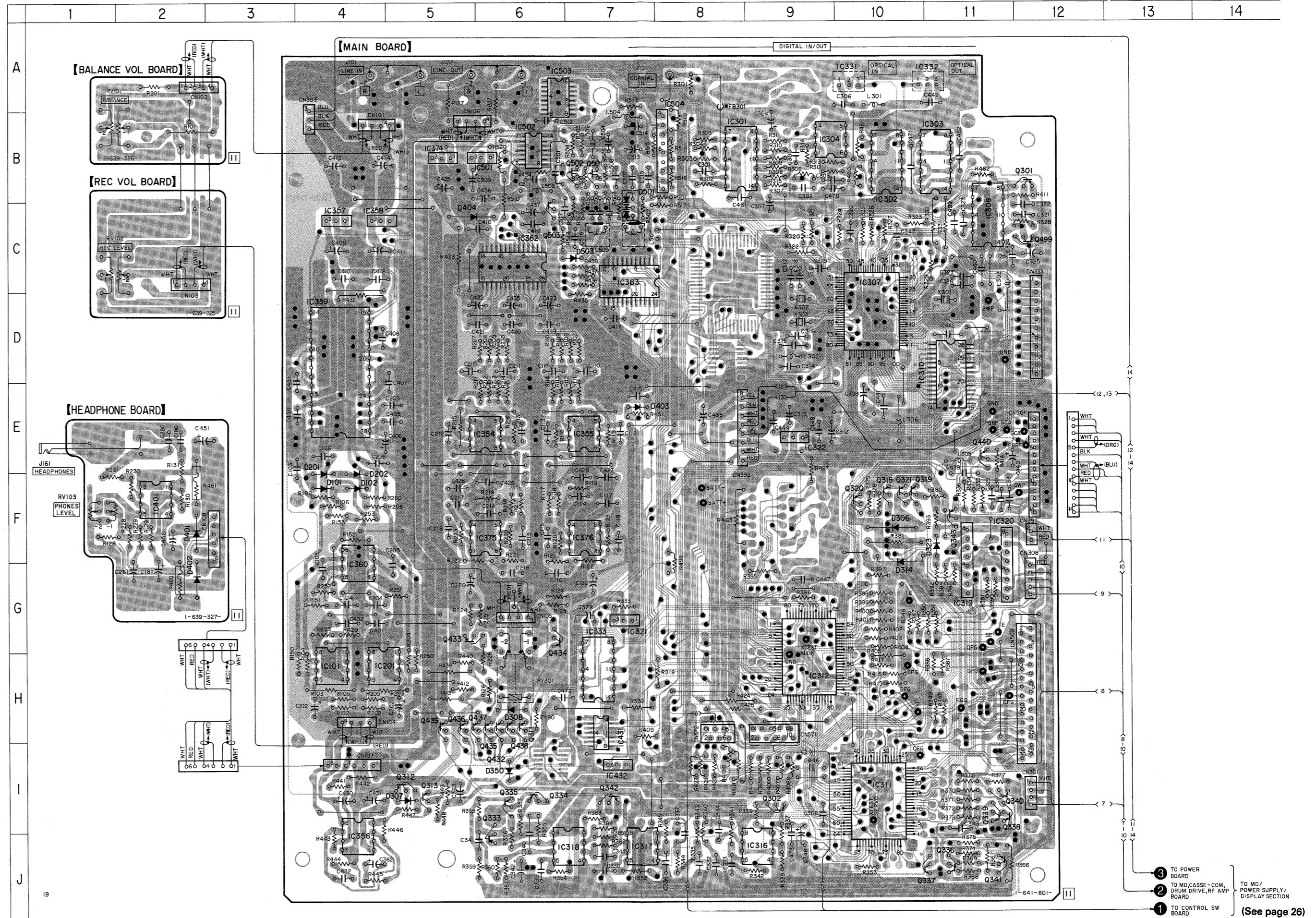

(See page 26)

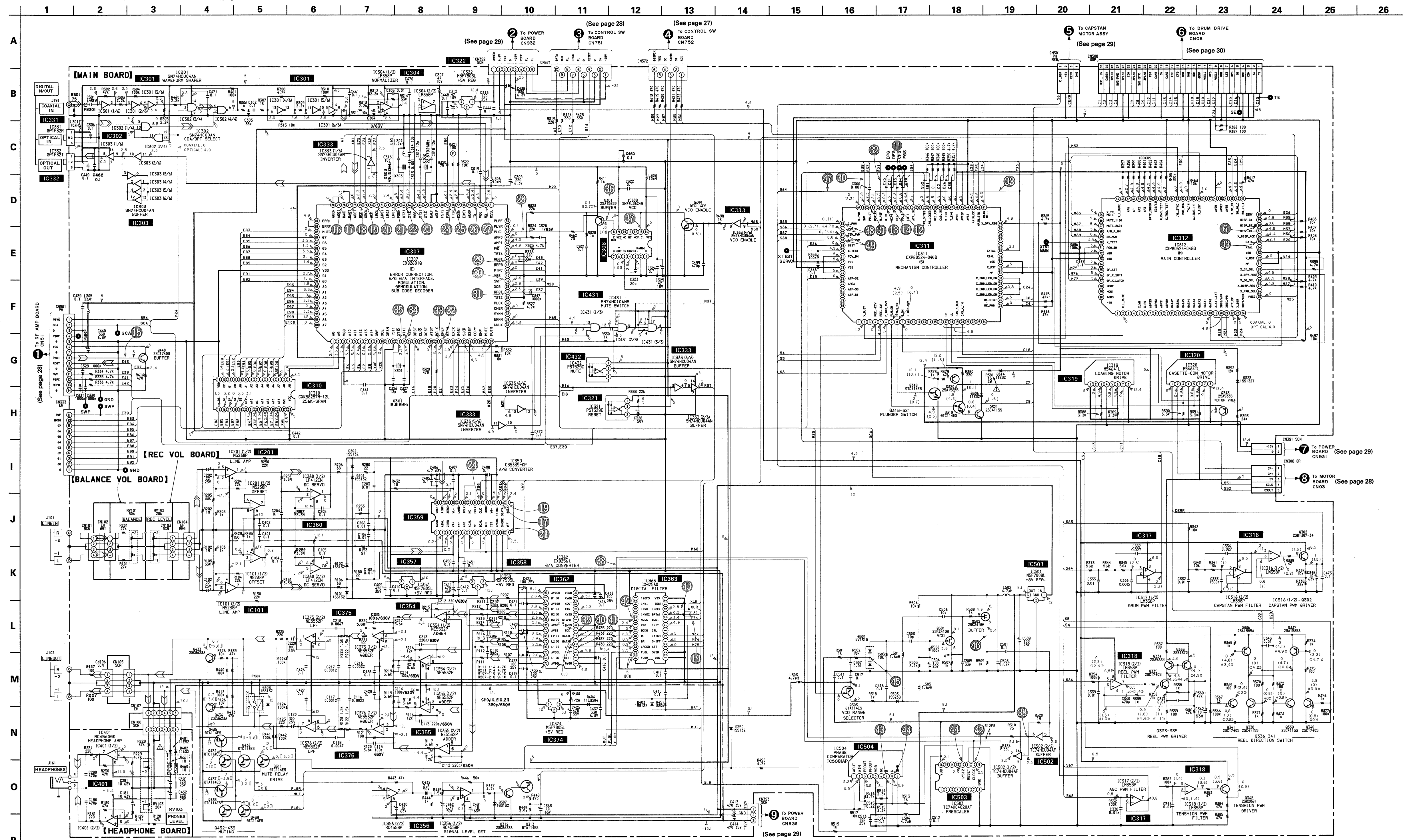

4-10. PIN FUNCTIONS

IC307 DAT Signal Processor (CXD2601AQ)

This processor is an LSI to process recording and playback signals of the R-DAT system, in a single chip and provided with digital PLL, modem, error correction circuit, digital I/O, RAM control circuit, etc.

Pin No.	Pin Name	I/O	Description
1, 2	A08, A09	I/O	RAM address A08, A09
3	VDD	—	5 V
4-6	A10-A12	I/O	RAM address A10-A12
7, 8	A13, A14	O	RAM address A13, A14
9	XWE	O	RAM write enable signal
10	XOE	O	RAM output enable signal
11	XEAN	O	External addressing bus interrupt enable signal (Not in use)
12	TST1	I	Test pin (normally "L")
13	XT1O	O	18.816 MHz crystal oscillator output
14	XT1I	I	18.816 MHz crystal oscillator input
15	VSS	—	GND
16	XRST	I	Reset pin (normally "H")
17	CLKO	I/O	18.816 MHz clock output (Not in use)
18	XCST	I/O	SYEK (internal system clock) generation CLKO division timing signal (Not in use)
19	ATSY	I	ATF sync signal input
20	MCLK	O	9.408 MHz clock output
21	DREF	O	Drum servo reference signal
22	SBPM	O	Discrimination signal determining whether the subcode I/O clock (EXCK) is accepted ("L": accept, "H": ignore) (Not in use)
23	EXCK	I	Subcode I/O data transfer clock (DUTY50)
24	SDSI	I	Subcode serial data input
25	SDSO	O	Subcode serial data output
26	SBSY	O	Subcode I/O sync signal
27	COPY	O	Copy data output (Not in use)
28	EMP	O	Emphasis data output (Not in use)
29	MUTE	I	Mute pin
30	MUTM	O	Mute discrimination signal ("H": muted)
31	UNLK	O	RX PLL lock discrimination signal ("H": locked)
32	ERMN	O	Detects presence or absence of RF ("H": RF present, "L" during REC)
33	SYMN	O	C1 check result for RF ("H": OK) (Not in use)
34	CHER	I	Signal for discriminating whether C2 is 1 or 2 times (C2 → C1 → C2 or C1 → C2) ("H": 1 time, "L": 2 times) (Not in use)
35	PLCK	I/O	RF PLL clock output (Not in use)
36	TST2	I	Test pin (normally "L")
37	RFDT	I	RF signal input
38	XCS	I	Subcode I/O chip select ("L": select)
39	SWP	I	RF switching pulse ("L": A-CH, "H": B-CH)
40	VSS	—	GND
41	PIPC	O	REC data PILOT/PCM discrimination signal ("H": PILOT, during playback: always "L")
42	REPB	O	Record/playback switching signal ("H": record)
43	REDT	O	Recording signal output, fixed "L" during playback
44	TST4	I	Test pin (normally "L")
45	PDO	O	RX APLL PD output (comparator output)
46	AMPI	I	RX APLL oscillator cell amp input
47	AMPO	O	RX APLL oscillator cell amp inverted output
48	PLCO	I	RX APLL external VCO clock input

Pin No.	Pin Name	I/O	Description
49	PLVR	O	RX APLL comparison signal when external comparator is active (Vin) Not in use
50	PLVF	O	RX APLL comparison signal when external comparator is active (Rin) Not in use
51	MSSL	I	Master/slave setting ("H": master (fixed with the equipment), "L": slave)
52	RX	I	Digital input
53	VDD	—	5 V
54	TX	O	Digital output
55	AUDR	I	Audio mode/data recorder mode setting ("H": audio mode, "L": data recorder mode)
56	EXSY	I/O	Complete copy sync signal (25/3 - 100/3 Hz)
57	EXSN	I/O	Complete copy sync signal (25/3 - 100/3 Hz)
58	F128	I/O	128fsCK (normal)/256fsCK (×2) (DUTY50)
59	F256	O	256fsCK (normal)/512fsCK (×2) (DUTY50)
60	F512	O	512fsCK (normal)/512fsCK (×2) (DUTY50)
61	ADLF	I	Signal for discriminating whether ADDT serial data is MSB first or LSB first ("H": LSB first)
62	DALF	I	Signal for discriminating whether DADT serial data is MSB first or LSB first ("H": LSB first)
63	XT20	O	22.5792 MHz crystal oscillator output
64	XT21	I	22.5792 MHz crystal oscillator input
65	VSS	—	GND
66	XT30	O	49.152 MHz crystal oscillator output (24.576 MHz in B mode)
67	XT31	I	49.152 MHz crystal oscillator input (24.576 MHz in B mode)
68	FSEN	I	F128, BCK, LRCK input/output switch ("H": output)
69	LR03	O	LR02 inversion
70	LR02	O	LRCK 16BCK delay signal
71	LR01	O	LRCK 15BCK delay signal
72	LRCK	I/O	fs (normal)/2fs (×2) ("L": L-CH, "H": R-CH)
73	WCK	I/O	2fs (normal)/4fs (×2) (input mode only for testing)
74	XBCK	O	BCK inversion
75	BCK	I/O	64fs (normal)/128fs (×2)
76	ADDT	I	Serial AD data (complement of 2)
77	DADT	O	Serial DA data (complement of 2)
78	DADO	I	Digital output (DA) data input (normally connected to DADT)
79	ADDI	O	Digital input (AD) data output (normally connected to ADDN)
80	ADDN	I	Digital input (DA) data input
81	ERRI	I	Digital output V-FLAG data input (normally connected to ERRF)
82	ERRF	O	Signal output for discriminating whether or not DADT has interpolated data ("H": interpolated data)
83	MUTG	O	Error correction status monitor trigger
84-89	D7-D2	I/O	RAM data bus D7-D2
90	VSS	—	GND
91, 92	D1, D0	I/O	RAM data bus D1, D0
93-100	A00-A07	I/O	RAM address A00-A07

IC311 Mechanism/Servo Micon (CXP80524-046Q)

The mechanical deck servo systems are controlled by the captioned micon according to instructions from the main micon (IC312).

Pin No.	Pin Name	I/O	Connected to	Description
1		O		Not in use
2	<u>BUSY</u>	O	Main Micon	Busy (Active "L") to the Main Micon
3		O		Not in use
4	REEL_CCW	O	Mechanism	Reel motor CCW ("L": RVS direction) } *1
5	REEL_CW	O	Mechanism	Reel motor CW ("H": FWD direction) }
6	C_DIR_RVS	O	Mechanism	Capstan Direction ("L": FWD, "H": RVS)
7	PLN_ON	O	Mechanism	Plunger On
8	PLN_KICK	O	Mechanism	Plunger Kick
9	D_ON	O	Mechanism	Drum On ("H": The drum is revolving)
10	D_DIR_RVS	O	Mechanism	Not in use
11-16		O		Not in use
17	LE	O	Mechanism	Loading Motor Eject } *2
18	LL	O	Mechanism	Loading Motor Load }
19	CAS_M_OUT	O	Mechanism	Cassette control motor Out } *3
20	CAS_M_IN	O	Mechanism	Cassette control motor In }
21-24		—		Not in use
25	RE_FWD	I	Mechanism	Encoder SW2 } *4
26	RE_STOP	I	Mechanism	Encoder SW1 }
27-30	<u>END_LED_ON</u>	O	Mechanism	End sensor ON Illuminated upon "L" (rectangular wave of about 1kHz). It is not output unless a cassette is mounted ("H").
31	MP	I		Microprocessor mode selected (the equipment is fixed at "L").
32	<u>RST</u>	I		System Reset (low active)
33	Vss	—		Power terminal (GND)
34	XTAL	O		System Clock Output (Not in use)
35	EXTAL	I	CXD2601AQ	System Clock Input (9.408 MHz)
36-39		—		Not in use
40	X_SRV_REQ	I	Main Micon	Request for communication from the Main Micon
41	MAIN_DT_I	I	Main Micon	Serial Input from the Main Micon
42	MAIN_DT_O	O	Main Micon	Serial Output to the Main Micon
43	MAIN_CK	I	Main Micon	Serial Clock with the Main Micon
44	AVss	—		GND for A/D
45	AVref	—		Reference Voltage for A/D (+5 V)
46	AVdd	—		Power Supply for A/D (+5 V)
47	T_END	I	Mechanism	Take-up side end sensor input (analog) } Magnetic matter: 0V,
48	S_END	I	Mechanism	Supply side end sensor input (analog) } Leader tape: AC (*5)
49	CAS_IN	I	Mechanism	Cassette-in switch (S01). "H": Cassette is mounted.
50	REC_EN	I	Mechanism	Rec-enable switch (S01). "H": REC enabled.
51	CAS_LCKed	I	Mechanism	Casecon locked Upon completion of loading: "H"
52	CAS_OUTed	I	Mechanism	Casecon outed Upon completion of loading OUT: "H"
53		I		Not in use
54	ATF_IN	I	RF Amp	ATF PILOT input
55	FG_T	I	Mechanism	Reel FG (T Side) } 6/24Hz (Small reel diameter) -
56	FG_S	I	Mechanism	Reel FG (S Side) } 15/24Hz (Large reel diameter) (In SP FWD)
57	C_FG	I	Mechanism	Capstan FG SP: 674 Hz, LP: 337 Hz
58	D_FG	I	Mechanism	Drum FG 400 Hz: LP REC, 800 Hz: Other modes
59	D_PG	I	Mechanism	Drum PG } Other than LP REC: 800/24Hz
60	D_REF	I	CXD2601AQ	Drum Reference } In LP REC: 400/24Hz

Pin No.	Pin Name	I/O	Connected to	Description
61	MST_CK	I	CXD2601AQ	Master clock (9.408MHz)
62	PB_DT	I	RF Amp	PB Data input to create ATF Sync
63	SWP	O	CXD2601AQ	Switching Pulse "L": Ach, "H": Bch
64	D_PWM	O	Mechanism	PWM Out for Drum
65	C_PWM	O	Mechanism	PWM Out for Capstan
66	PWM_R	O	Mechanism	PWM Out for Reel
67	TEN_PWM	O	Mechanism	PWM Out for Tension Regulator Plunger
68	AGC_PWM	O	RF Amp	PWM Out for AGC
69	SBSY	I	CXD2601AQ	↓ of subsync is detected (XINT2).
70	TEST	I	Pull-up	Test Mode (active "L")
71	POW_DN	I		Not in use
72	Vdd	—		Power terminal (+5 V)
73	Vss	—		Power terminal (GND)
74		—		Not in use
75	ATF_S2	O	CXD2601AQ	ATF Sampling Pulse
76-80		—		Not in use

* 1 Reel motor control

	CCW (counterclockwise)	CW (clockwise)
STOP (only in POWER ON)	L	L
FWD	L	H
RVS	H	L
Prohibit	H	H

*2 Loading motor control

	LE	LL
—	L	L
LOAD	L	H
EJECT	H	L
Brake	H	H

*3 Casecon motor control

	OUT	IN
—	L	L
IN	L	H
OUT	H	L
Brake	H	H

*4 Encoder

RF-FWD	RE_STOP	Position
L	L	EJECT
L	H	STOP UNLD-STOP
H	L	FWD
H	H	STOP-FWD

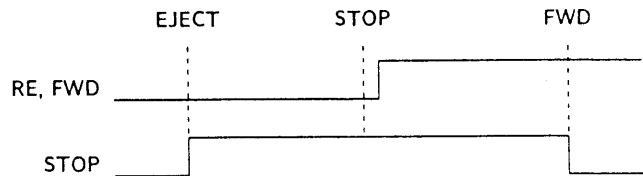

*5 End sensor

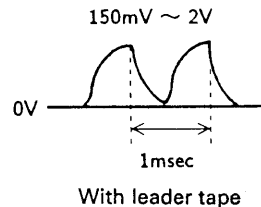

IC312 Main Micon (CXP80524-048Q)

This Micon generally controls the operation of the equipment while exchanging data with the display micon (IC701) and mechanism/servo micon (IC311) in serial communications, including the DAT signal processor (IC307), digital filter (IC363) and other IC.

Pin No.	Pin Name	I/O	Connected to	Description
1		O		Not in use
2	$\overline{\text{L_MUTE}}$	O	Line Out	Line Mute (Active "L")
3		O		Not in use
4		O		Not in use
5	$\overline{\text{WRT}}$	O	Clock IC	Write request (Active "L")
6	RD	O	Clock IC	Read request (Active "L")
7-10	ADRS_3-0	O	Clock IC	Address 3-0 (Address BUS)
11-14	DATA_7-4	I/O		DATA 7-4 (DATA BUS). Not in use with the equipment
15-18	DATA_3-0	I/O	Clock IC	DATA 3-0 (DATA BUS)
19	$\overline{\text{ATT_EXT}}$	O	CXD1136Q	Fade attenuator ck externally selected (Active "L")
20	$\overline{\text{DIG/ANA}}$	O	CXD1136Q	Fade In/Out switching for DIG ("L")/ANA ("H")
21	$\overline{\text{REC/PB}}$	O	CXD1136Q	Fade In/Out REC switching for ("L")/PB ("H")
22	$\overline{\text{ATT_CK}}$	O	CXD1136Q	Clock for fade In/Out
23	$\overline{\text{DTR}}$	O	CXD2601AQ	Audio use ("H")/Data Recorder use ("L"). Becomes "L" in after-recording and searching.
24	$\overline{\text{OPT/COA}}$	O	Digital I/O	Switching for Optical ("L")/Coaxial ("H")
25	FS32	O	1Bit DAC	"H" upon Fs = 32kHz. "L" for others.
26	$\overline{\text{RAM_SEL}}$	O		Not in use
27	$\overline{\text{DISP_REQ}}$	O	Display Micon	Request for communication with the Display Micon ("L" Active)
28	$\overline{\text{SD_SEL}}$	O	CXD2601AQ	Request for communication with CXD2601 ("L" Active)
29	$\overline{\text{SRV_REQ}}$	O	Mechanism Micon	Request for communication with the Mechanism Micon ("L" Active)
30	$\overline{\text{CLOCK_SEL}}$	O	Clock IC	Clock IC chip selected
31	$\overline{\text{MP}}$	I		Microprocessor mode selected (fixed at "L" with the equipment)
32	$\overline{\text{RST}}$	I		System Reset ("L" Active)
33	Vss	—		Power terminal (GND)
34	XTAL	O		System Clock Output (Not in use)
35	EXTAL	I	CXD2601AQ	System Clock Input (9.048 MHz)
36	$\overline{\text{DISP_ACK}}$	I	Display Micon	ACKnowledge (Active "L")
37	DISP_DT_I	I	Display Micon	Serial Input
38	DISP_DT_O	O	Display Micon	Serial Output
39	DISP_CK	I	Display Micon	Serial clock
40	$\overline{\text{SBSY}}$	I	CXD2601AQ	Subcode sync
41	SR_DT_IN	I	}CXD2601AQ & Mechanism Micon	Serial Data In
42	SR_DT_OUT	O		Serial Data Out
43	$\overline{\text{SR_CK}}$	I/O		Serial clock (In/Out) to Sub Code Interface
44	AVss	—		GND for A/D
45	AVref	—		Reference Voltage for A/D (+5 V)
46	AVdd	—		Power Supply for A/D (+5 V)
47		I		Not in use
48		I		Not in use
49	$\overline{\text{BUSY}}$	I	Mechanism Micon	Mechanism servo micon Busy (Active "L")
50	AU_BUS_IN	I	Audio Bus	Not in use

Pin No.	Pin Name	I/O	Connected to	Description
51	TM_IN	I	Clock IC	TM_OUT for clock IC
52	MUT_MON	I	CXD2601AQ	Mute monitor (Active "H")
53	LVL_SYNC	I	Audio Block	Start ID is written by entering Level Sync Input audio.
54		I		Not in use
55	$\overline{\text{TRQ_TEST}}$	I	Pull-up	Not in use
56	$\overline{\text{NO_CAS_TEST}}$	I	Pull-up	Not in use
57	TIME_24/12	I	Pull-up	Time indication "H": 12 hours (AM, PM) "L": 24 hours display
58	DATE_ORDER	I	Pull-up	Order of DATA display "H": Year, month and day "L": Month, day and year
59-62	AF_3-0	I	Pull-up	Not in use
63		O	Pull-up	Not in use
64	$\overline{\text{L_MUTE}}$	O		Line Mute (Active "L"). Not in use with the equipment (Not in use)
65	$\overline{\text{TR_MUTE}}$	O	Line Out	Transistor Mute (Active "L")
66	MUTE_1136	O		Not in use
67	MUTE_2601	O	CXD2601AQ	Mute for CXD2601 (Active "H")
68	A_D_PWR_DWN	O	CS5339	A/D Converter Power Down Mode (Active "H"). The AD converter is turned OFF upon digital input/output.
69	ER_MON	I	CXD2601AQ	Error Monitor (Data Valid)
70	$\overline{\text{TEST}}$	I	Pull-up	Test Mode (Active "L")
71	POW_DN	I	+5 V	Not in use
72	Vdd	—		Power terminal (+5V)
73	Vss	—		Power terminal (GND)
74		—		Not in use
75	D_F_ATT	O	CXD2560M	Communication line (Serial Data) with Digital Filter
76	$\overline{\text{D_F_SHIFT}}$	O	CXD2560M	Communication line with Digital Filter (Shift Clock; shifted by ↓ and taken in by ↑)
77	$\overline{\text{D_F_LATCH}}$	O	CXD2560M	Communication line (Latch Pulse) with Digital Filter
78, 79	MODE2, 1	O		Mode Control of the RF amplifier (Not in use)
80		O		Not in use

IC362 Pulse D/A Converter (CXD2561M-1)

The Converter is a small, high-performance 1 bit pulse D/A converter that provides 4 asymmetrical PWM wave outputs in each ch of L/R.

Pin No.	Pin Name	I/O	Description
1	DV _{DD}	—	Digital power supply
2	TEST	I	Test terminal. Normally fixed at "L."
3	INIT	I	Again synchronized at the buildup edge of the signal.
4	LRCKI	I	LRCK input
5	DRI	I	Rch data input
6	DLI	I	Lch data input
7	BCKI	I	BCK input
8	DV _{SS}	—	Digital GND
9	512Fs	O	512Fs output
10	XV _{SS}	—	Clock GND
11	XIN	I	X'tal oscillator input terminal (512Fs)
12	XOUT	O	X'tal oscillator output terminal
13	XV _{DD}	—	Clock power supply
14	V _{SUB}	—	Substrate. Connected to GND.
15	AV _{DD} R	—	Analog power supply
16	R1 (+)	O	Rch PLM output 1 (normal phase)
17	AV _{SS} R	—	Analog GND
18	R1 (-)	O	Rch PLM output 1 (reverse phase)
19	R2 (+)	O	Rch PLM output 2 (normal phase)
20	R2 (-)	O	Rch PLM output 2 (reverse phase)
21	AV _{DD}	—	Analog power supply
22	AV _{SS}	—	Analog GND
23	L2 (-)	O	Lch PLM output 2 (reverse phase)
24	L2 (+)	O	Lch PLM output 2 (normal phase)
25	L1 (-)	O	Lch PLM output 1 (reverse phase)
26	AV _{SS} L	—	Analog GND
27	L1 (+)	O	Lch PLM output 1 (normal phase)
28	AV _{DD} L	—	Analog power supply

IC363 Digital Filter (CXD2560M)

The Filter is a digital audio 8x oversampling digital filter with builtin L/R 2ch filter, noise shaping attenuator, soft muting deemphasis, etc.

Pin No.	Pin Name	I/O	Description
1	V _{SS}	—	Power terminal (GND)
2	SYSM	I	System mute input. Effective upon "H"
3	ATT	I	ATT data input in CTL "L."
4	SHIFT	I	EMP input upon CTL "H."
5	LATCH	I	Shift clock input upon CTL "L."
6	CTL	I	FS32 input upon CTL "H."
7	INIT	I	Latch clock input upon CTL "L."
8	BCKI	I	FS48 input upon CTL "H."
9	DATAI	I	Pull-down in the IC. Direct input mode upon "H." Serial transfer mode upon "L."
10	LRCKI	I	Synchronized again at the buildup edge of the signal.
11	TEST	I	BCK input
12	V _{SS}	—	Data input
13	128Fs	O	LRCK input
14	INVI	I	Test terminal. Fixed at "L" during normal use.
15	INVO	O	Power terminal (GND)
16	INVO2	O	128Fs clock output
17	MCLK	I	Inverter input
18	V _{DD}	—	Inverter output
19	BCKO	O	Master clock input (f=512Fs)
20	DL	O	Power terminal (+5 V)
21	DR	O	BCK output
22	LRCKO	O	Lch data output
23	FLGL	O	Rch data output
24	FLGR	O	LRCK output
			Lch \emptyset mute flag output
			Rch \emptyset mute flag output

IC701 Display Micon (CXP5058H-657Q)

The Micon controls key input, FL tube display, remote control signal input, level meter (IC702) and EEPROM (IC703) according to instructions from the Main Micon (IC312).

Pin No.	Pin Name	I/O	Connected to	Description
1-18	e_-v_SEG	O	FL tube FL701	FL Segment 'e'-'v'
19-28	10_-1_G	O	FL tube FL701	FL Grid #10-#1
29	$\overline{\text{DSP_REQ}}$	I	MAIN Micon	Communication request ("L" Active)
30	XTAL	—	Ceramic oscillator	
31	EXTAL	I	Ceramic oscillator	4.19MHz ceramic oscillator
32	$\overline{\text{RST}}$	I		System Reset ("L" active)
33	NC	—		Not in use
34	Vdd	I		Power terminal (+5 V)
35-42	AD_0-7	I	Panel switch	Key input A/D converter input #0 - #7
43	NC	—		Not in use
44	DISP_CK	O	MAIN Micon	Shift clock
45	SO	O	MAIN Micon	Serial data OUT
46	SI	I	MAIN Micon	Serial data IN
47	$\overline{\text{DSP_ACK}}$	O	MAIN Micon	Acknowledge (Active "L")
48	REC_MODE	I	S703	REC MODE "H": Standard, "L": Long
49	$\overline{\text{TEST}}$	I	Pull-down	Test mode (Active "L")
50	$\overline{\text{CLOCK_SET}}$	I		Not in use
51-54	LVL_DT_0-3	I/O	Level Meter IC	Level Meter Data 0-3
55, 56	LVL_ADRS_0, 1	O	Level Meter IC	Level Meter Data 0, 1
57	$\overline{\text{LVL_RD}}$	O	Level Meter IC	Level Meter Read Mode (Active "L")
58	$\overline{\text{LVL_WR}}$	O	Level Meter IC	Level Meter Write Mode (Active "L")
59	$\overline{\text{LVL_SEL}}$	O	Level Meter IC	Level Meter IC Select (Active "L")
60	$\overline{\text{RM_SEL}}$	O	Open	External remote controller selected (not in use)
61	PY2	I	Pull-up	Not in use
62	RMC	I	Open	Not in use
63	$\overline{\text{RMC_CAT}}$	I	Pull-down	Remote control category "L": DAT1, "H": DAT2. Fixed at "L" with the equipment.
64	$\overline{\text{TR_MUTE}}$	I	IC431	Level meter mute (Active "L")
65	$\overline{\text{BUSY}}$	I	EEPROM	BUSY signal (Active "L")
66	ROM_DT_IN	I	EEPROM	Data input
67	ROM_DT_OUT	O	EEPROM	Data output
68	$\overline{\text{SHIFT_CK}}$	O	EEPROM	Shift clock
69	$\overline{\text{CE}}$	O	EEPROM	Chip enable
70	DTC/XPCM	I	Pull-up	Equipment model discrimination input. Fixed at "H" with the equipment
71	Vss	I		Power terminal (GND)
72	TX	—	Open	Not in use
73	NC	—	Open	Not in use
74	TEX	—	+5 V	Not in use
75	Vref	I	+5 V	Analog board reference voltage
76	Vfdp	I	-25 V	FL display tube driving voltage
77-80	a_-d_SEG	O	FL tube	FL Segment 'a'-'d'

SECTION 5 EXPLODED VIEWS

NOTE:

- -XX, -X mean standardized parts, so they may have some differences from the original one.
- Color Indication of Appearance Parts
Example:
KNOB,BALANCE(WHITE)...(RED)
 ↑ ↑
Parts color Cabinet's color

- Items marked "*" are not stocked since they are seldom required for routine service. Some delay should be anticipated when ordering these items.
- The mechanical parts with no reference number in the exploded views are not supplied.
- Hardware(# mark) list is given in the last of this parts list.
- G : Germany model

The components identified by mark Δ or dotted line with mark Δ are critical for safety.
Replace only with part number specified.

Les composants identifiés par une marque Δ sont critiques pour la sécurité.
Ne les remplacer que par une pièce portant le numéro spécifié.

5-1. CABINET SECTION

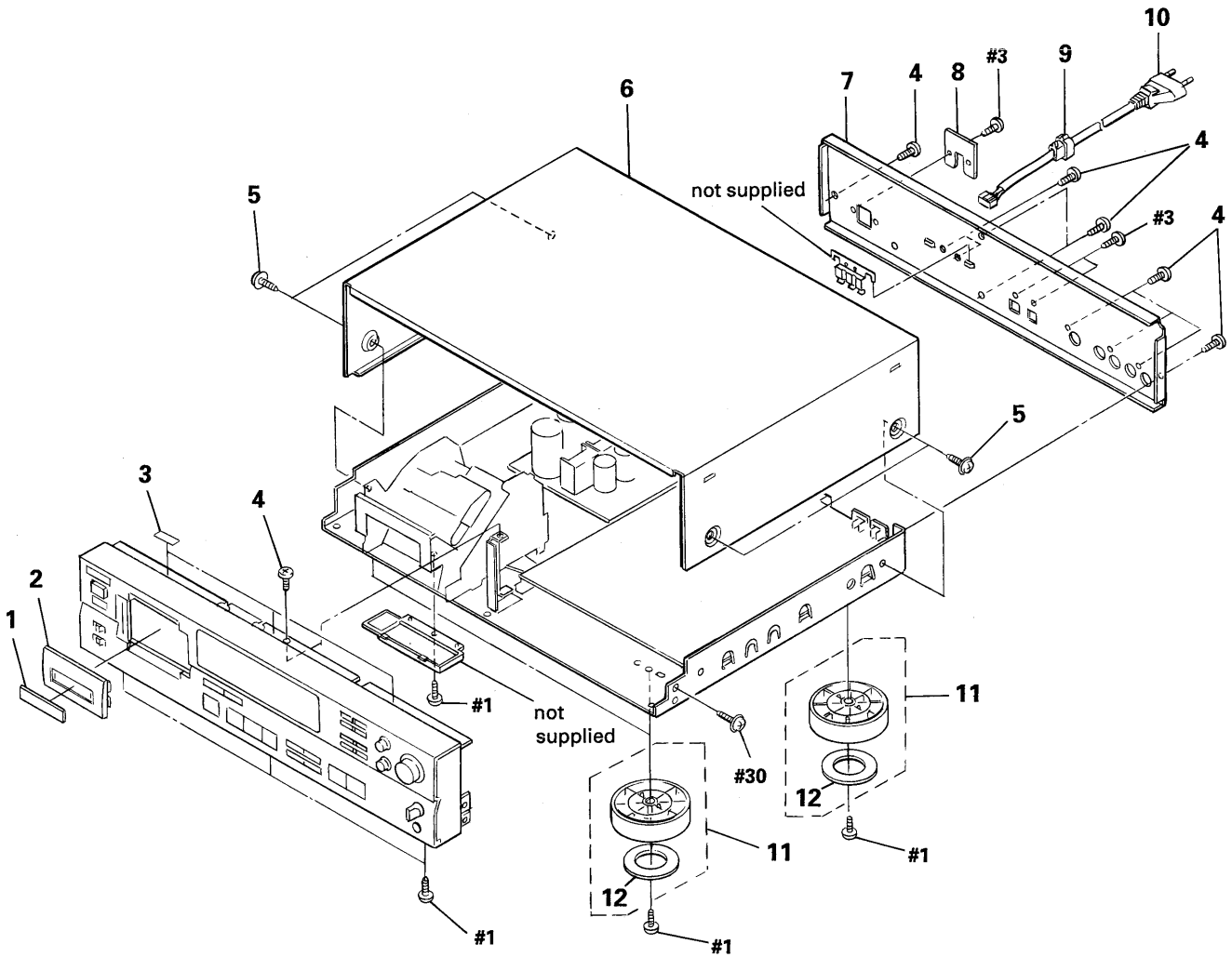

Ref. No.	Part No.	Description	Remarks	Ref. No.	Part No.	Description	Remarks
1	3-374-275-01	WINDOW (670)		8	* 4-923-873-01	BRACKET, CORD STOPPER	
2	3-374-279-01	HOLDER (670)		9	* 3-703-244-00	BUSHING (2104), CORD	
3	3-831-441-XX	CUSHION, SPEAKER		10	Δ 1-575-912-11	CORD, POWER (AEP, G)	
4	3-703-685-21	SCREW (+BV 3X8)		10	Δ 1-575-695-11	CORD, POWER (US, Canadian)	
5	3-363-099-01	SCREW (CASE +3X8 TP2)		11	X-3304-938-2	FOOT ASSY	
6	3-350-407-41	CASE		12	4-923-836-11	CUSHION	
7	* 3-368-712-81	PANEL, BACK (AEP, G)					
7	* 3-368-712-91	PANEL, BACK (US, Canadian)					

5-2. FRONT PANEL SECTION

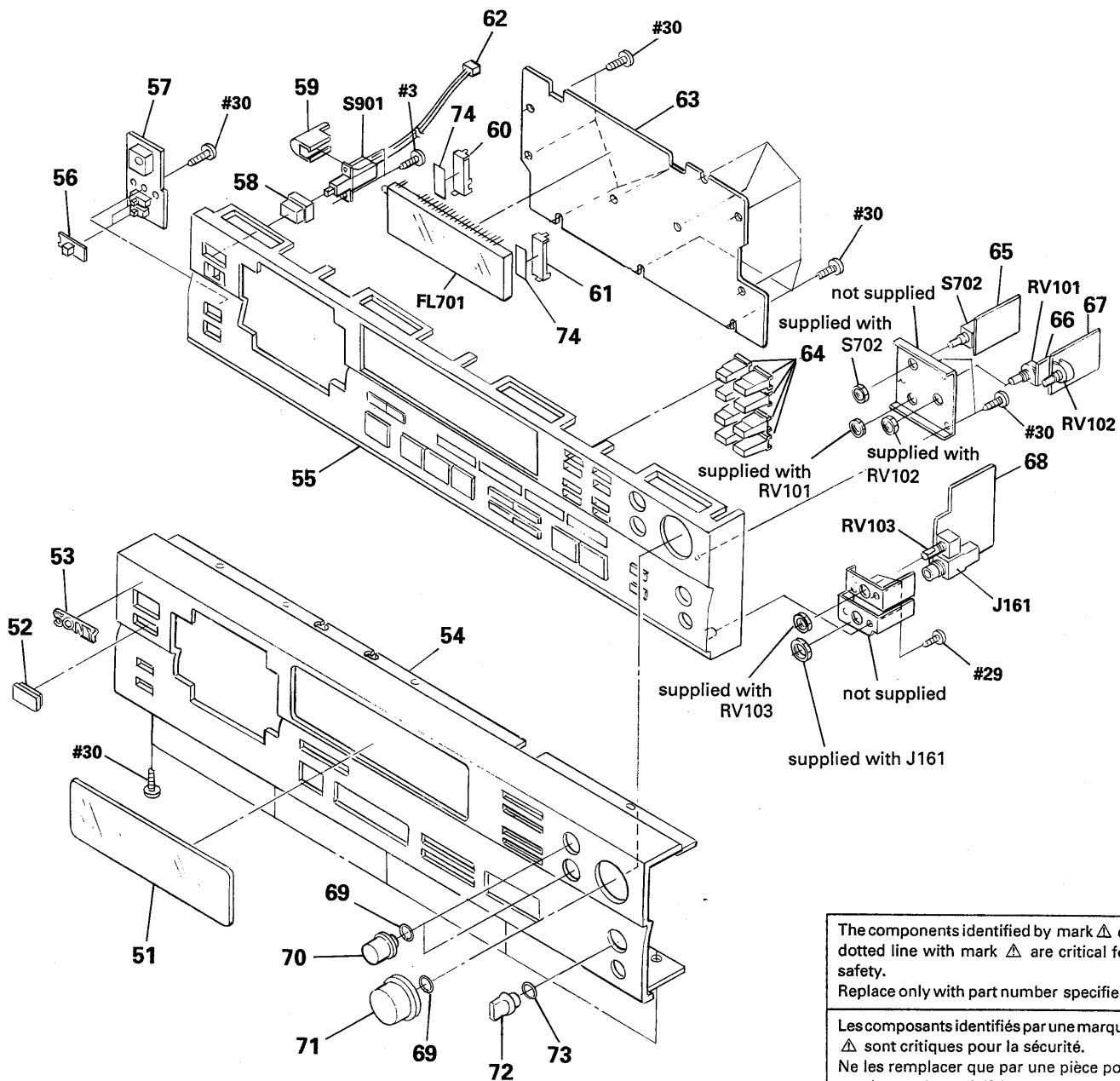

The components identified by mark Δ or dotted line with mark Δ are critical for safety. Replace only with part number specified.

Les composants identifiés par une marque Δ sont critiques pour la sécurité. Ne les remplacer que par une pièce portant le numéro spécifié.

Ref. No.	Part No.	Description	Remarks	Ref. No.	Part No.	Description	Remarks
51	3-368-698-01	WINDOW (FL TUBE)		64	3-364-927-01	BUTTON (10 KEY)	
52	3-364-919-11	FILTER		65	* 1-639-328-11	INPUT SW BOARD	
53	4-908-848-01	EMBLEM, SONY		66	* 1-639-326-11	BALANCE VOL BOARD	
54	3-374-281-01	PANEL (FRONT)		67	* 1-639-325-11	REC VOL BOARD	
55	X-3363-905-2	ESCUTCHEON (PANEL) ASSY		68	* 1-639-327-11	HEADPHONE BOARD	
56	4-931-421-11	KNOB (T & S)		69	3-356-957-01	SPRING	
57	* 1-639-329-11	TIMER SW BOARD		70	3-364-173-11	KNOB (BAL)	
58	4-917-460-01	KNOB, POWER		71	3-368-707-01	KNOB (REC LEVEL)	
59	3-575-524-00	COVER, POWER SWITCH		72	3-354-931-01	KNOB (DIA. 10)	
60	* 4-922-524-01	HOLDER (LEFT)		73	3-354-981-01	SPRING (SUS), RING	
61	* 4-922-523-01	HOLDER (RIGHT)		74	9-911-839-XX	CUSHION	
62	1-590-321-71	LEAD (WITH CONNECTOR)		FL701	1-519-672-11	INDICATOR TUBE, FLUORESCENT	
63	* A-2006-669-A	CONTROL SW BOARD, COMPLETE		S901 Δ	1-554-920-21	SWITCH, PUSH (AC POWER) (1 KEY) (POWER)	

5-3. CHASSIS SECTION

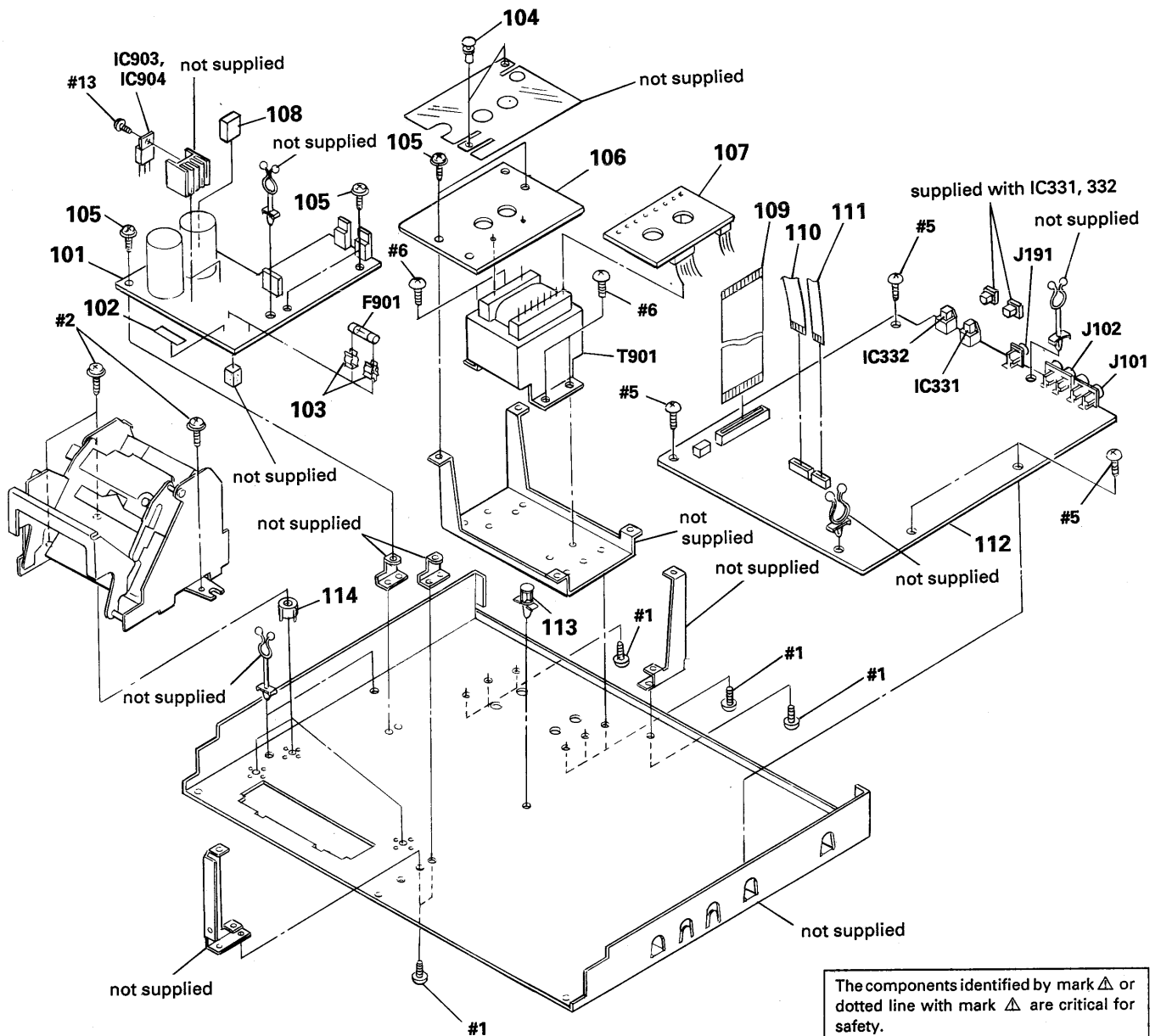

The components identified by mark Δ or dotted line with mark Δ are critical for safety. Replace only with part number specified.

Les composants identifiés par une marque Δ sont critiques pour la sécurité. Ne les remplacer que par une pièce portant le numéro spécifié.

Ref. No.	Part No.	Description	Remarks	Ref. No.	Part No.	Description	Remarks
101	* A-2006-670-A	POWER BOARD, COMPLETE		110	1-590-916-11	WIRE, FLAT TYPE (10 CORE)	
102	3-701-947-15	LABEL (T2. 5A), FUSE		111	1-590-914-11	WIRE, FLAT TYPE (6 CORE)	
103	Δ 1-533-213-31	HOLDER, FUSE		112	* A-2006-671-A	MAIN BOARD, COMPLETE	
104	4-812-134-00	RIVET NYLON, 3.5		113	* 3-670-570-00	SPACER, SUPPORT	
105	4-886-821-11	SCREW, S TIGHT, +PTTWH 3X6		114	3-368-709-01	HOLDER (MD)	
106	* 1-639-333-11	PRIMARY BOARD		F901	Δ 1-532-286-00	FUSE, TIME-LAG (T 2.5A) (AEP, G)	
107	* 1-639-332-11	RELAY BOARD		F901	Δ 1-532-744-11	FUSE, GLASS TUBE (2.5A) (US, Canadian)	
108	* 3-685-232-01	SPACER, VI		T901	Δ 1-450-557-11	TRANSFORMER, POWER (AEP, G)	
109	1-590-915-11	WIRE, FLAT TYPE (30 CORE)		T901	Δ 1-450-556-11	TRANSFORMER, POWER (US, Canadian)	

5-4. MECHANISM SECTION 1

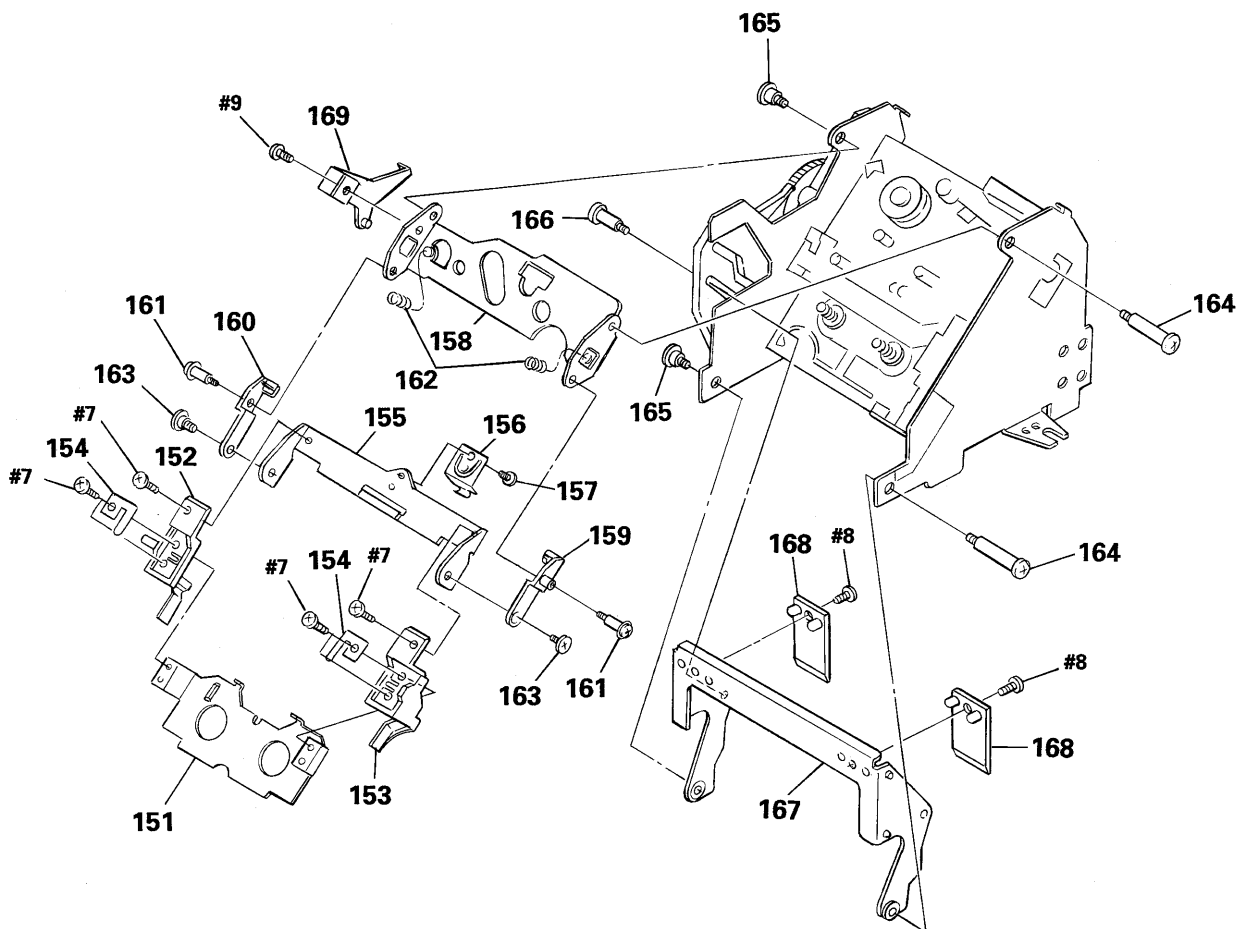

Ref. No.	Part No.	Description	Remarks	Ref. No.	Part No.	Description	Remarks
151	4-931-476-01	HOLDER (LOWER)		161	4-918-991-01	SCREW, STEP	
152	4-931-484-01	HOLDER (C-LEFT)		162	3-537-214-00	SPRING, COMPRESSION	
153	4-931-486-01	HOLDER (C-RIGHT)		163	3-312-161-00	SCREW, STEP, PRECISION	
154	3-366-308-01	SPRING (SIDE), PLATE		164	4-931-463-01	SCREW (STEP)	
155	* 4-931-485-01	HOLDER (C-INNER)		165	2-236-956-00	SCREW, STEP	
156	4-931-461-01	SPRING (CENTER), LEAF		166	4-931-471-01	SCREW (STEP)	
157	3-352-517-01	SCREW (M2X2.5)		167	4-931-474-01	HOLDER (WINDOW)	
158	* 3-369-235-01	PLATE, FULCRUM		168	4-931-469-01	PLATE, ORNAMENTAL	
159	4-931-481-01	ARM (LIMITER L)		169	* X-4919-020-1	JOINT ASSY	
160	4-931-473-01	ARM (LIMITER R)					

5-5. MECHANISM SECTION 2

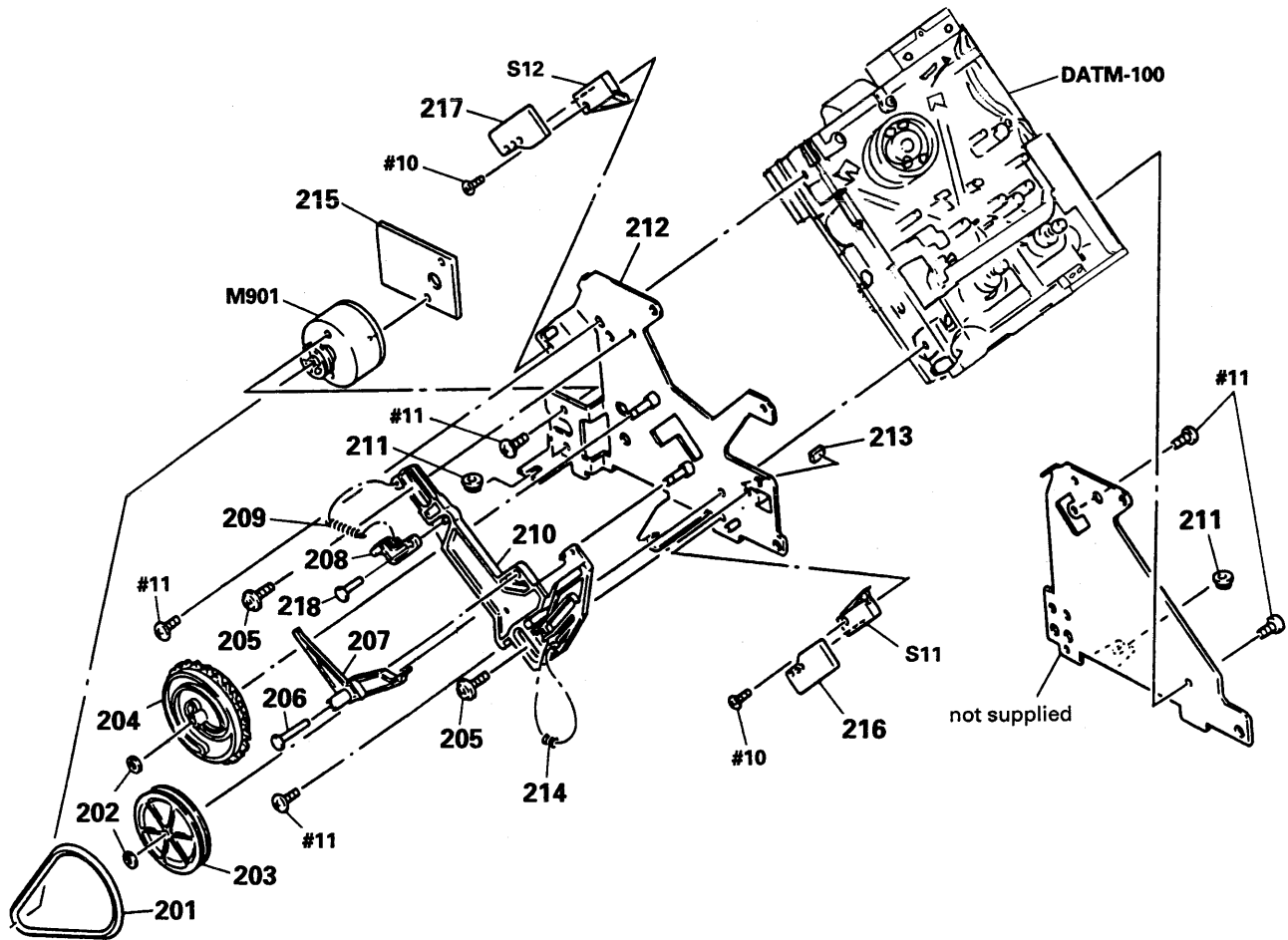

Ref. No.	Part No.	Description	Remarks	Ref. No.	Part No.	Description	Remarks
201	4-931-470-01	BELT (DRIVING)		212	* X-4919-023-1	PLATE ASSY, SIDE	
202	3-307-948-21	WASHER, NYLON		213	9-911-863-XX	SPACER	
203	4-931-459-01	PULLEY		214	3-537-215-00	SPRING, COMPRESSION	
204	4-931-477-01	GEAR (CAM)		215	* 1-639-646-11	MOTOR BOARD	
205	4-932-336-01	SCREW (STEP)		216	* 1-639-647-11	SW (IN) BOARD	
206	4-931-468-01	SHAFT (PRESS FITTING)		217	* 1-639-648-11	SW (OUT) BOARD	
207	4-931-490-01	LEVER (LINK)		218	4-936-626-01	SHAFT (ARM PRESS FITTING)	
208	4-931-460-01	ARM (SLIDER)		S11	1-570-975-11	SWITCH, SLIDE (CASSETTE TABLE IN)	
209	3-549-810-00	SPRING, TENSION		S12	1-572-247-11	SWITCH, SLIDE (CASSETTE TABLE OUT)	
210	4-931-492-01	SLIDER (CAM)		M901	A-2003-448-A	MOTOR ASSY (CASSETTE COMPARTMENT)	

5-6. MECHANISM SECTION 3
(DATM-100)

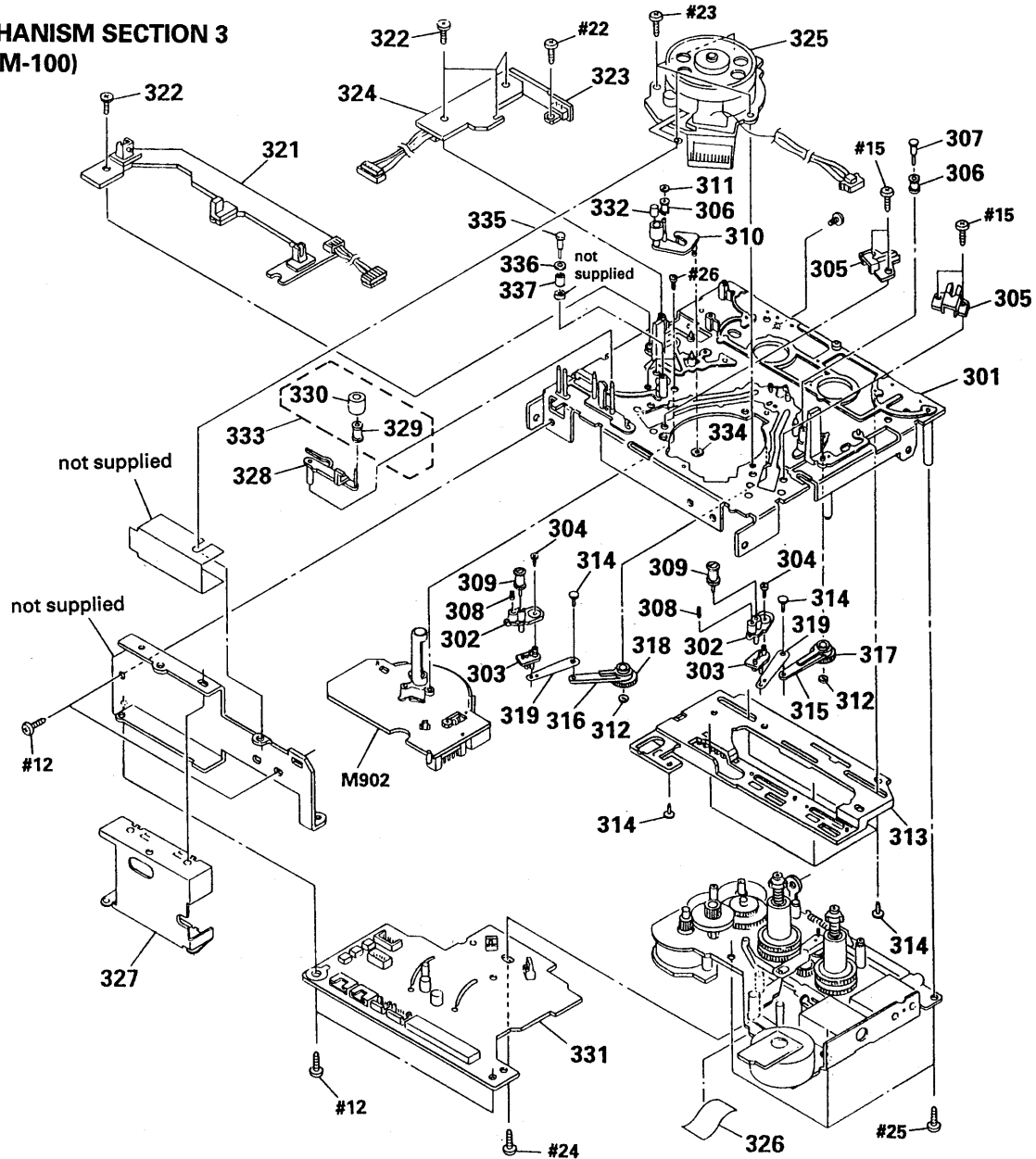

Ref. No.	Part No.	Description	Remarks	Ref. No.	Part No.	Description	Remarks
301	* 3-368-462-01	CHASSIS (OUTSERT), MECHANIAL		319	3-368-415-01	SHAFT (LOAD LEVER JOINT)	
302	* 3-368-390-01	BASE (#1 GUIDE)		321	* 1-639-305-11	TOP END SENSOR BOARD	
303	3-368-409-01	JOINT (#1 GUIDE)		323	* 1-639-301-11	RGN SW BOARD	
304	3-368-413-01	SCREW, +P (1) B1. 4X2. 5		324	* 1-639-306-11	CAM SLIDER BOARD	
305	* 3-368-442-01	CATCHER		325	8-848-567-11	DRUM ASSY DOU-03A	
306	3-368-399-01	GUIDE, ROLLER		326	9-911-835-XX	SPACER	
307	3-368-428-01	SHAFT (ROLLER GUIDE)		327	* A-2001-587-A	RF COMPLETE ASSY	
308	3-368-436-01	SPRING (#1 GUIDE), COMPRESSION		328	3-368-459-01	LEVER (CLEANER)	
309	X-3337-643-1	GUIDE (RIC) ASSY, ROLLER		329	3-353-812-01	COLLAR (ROLLER)	
310	X-3363-025-1	PINCH (LEVER) ASSY		330	3-352-518-01	ROLLER (CLEANER)	
311	3-315-384-31	WASHER, STOPPER		331	* A-2056-488-A	DRUM DRIVE BOARD, COMPLETE	
312	3-368-398-01	BUSHING		332	3-337-626-01	CAP, PINCH ROLLER	
313	* A-2003-708-A	SLIDER ASSY, CAM		333	X-3337-655-1	ROLLER (CLEANER) ASSY	
314	3-372-761-01	SCREW (M1. 7X4), TAPPING		334	3-321-813-01	WASHER	
315	3-368-427-01	LEVER (LOAD-T)		335	3-375-209-01	SHAFT (FIXED GUIDE)	
316	3-368-426-01	LEVER (LOAD-S)		336	3-337-677-01	FLANGE	
317	3-368-444-01	GEAR (LOAD-T)		337	3-337-676-01	GUIDE, FIXED	
318	3-368-443-01	GEAR (LOAD-S)		M902	8-835-361-01	MOTOR, DC U-17B (CAPSTAN)	

5-7. MECHANISM SECTION 4
(DATM-100)

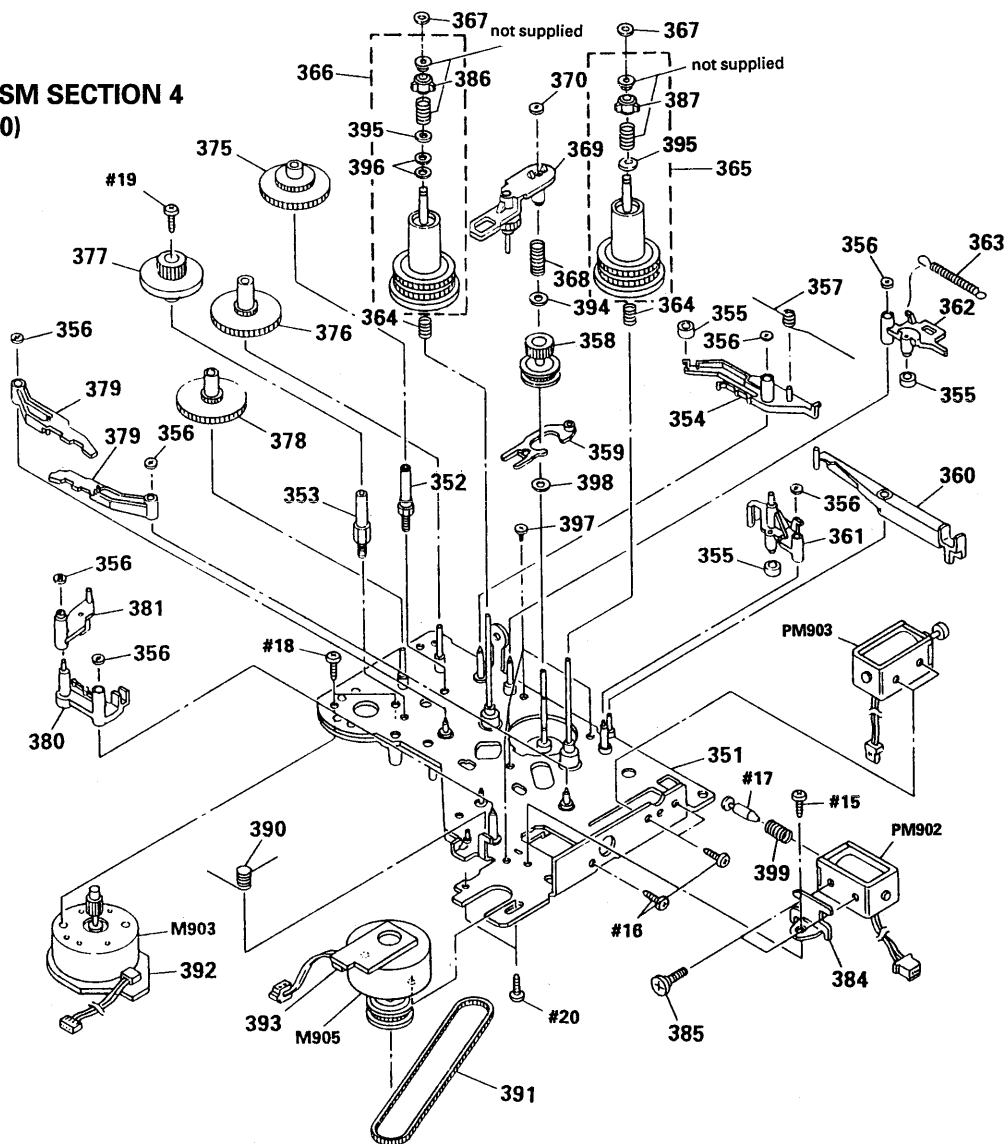

Ref. No.	Part No.	Description	Remarks	Ref. No.	Part No.	Description	Remarks
351	* A-2003-857-A	CHASSIS (REEL) ASSY		378	3-368-402-01	GEAR (CAM DRIVE A, B)	
352	* 3-368-420-01	SHAFT (CAM DRIVE GEAR C)		379	X-3363-024-1	LEVER (BT) ASSY	
353	* 3-368-419-01	SHAFT (CAM DRIVE GEAR D)		380	* 3-368-451-01	LEVER (BT SOLENOID)	
354	* 3-368-455-01	LEVER (GEAR LOCK)		381	* 3-368-454-01	LEVER (BT SELECTION)	
355	3-368-418-01	TUBE (BREAK)		384	* 3-368-416-01	BRACKET (B. T SOLENOID)	
356	3-368-398-01	BUSHING		385	3-368-423-01	SCREW (M2. 6), STEP	
357	3-368-430-01	SPRING (GEAR LOCK)		386	2-623-736-01	CLAW (C) (LEFT), REEL	
358	X-3363-022-1	GEAR (REEL DRIVE) ASSY		387	2-623-752-01	CLAW (C) (RIGHT), REEL	
359	* 3-368-411-01	SLIDER (REEL LOCK)		390	3-368-431-01	SPRING (B. T SOLENOID)	
360	* 3-368-453-01	LEVER (BRAKE SOLENOID)		391	3-368-417-01	BELT (170TN10-1.0T), TIMING	
361	* 3-368-447-01	LEVER (BRAKE S)		392	* 1-639-303-11	CAM MOTOR BOARD	
362	* 3-368-446-01	LEVER (BRAKE T)		393	* 1-639-304-11	REEL MOTOR BOARD	
363	3-368-438-01	SPRING (BREAK), TENSION		394	3-738-212-21	RETAINER, THRUST, REEL TABLE	
364	3-368-432-01	SPRING (FF/REW), COMPRESSION		395	3-701-443-11	WASHER	
365	A-2003-709-C	TABLE (S) ASSY, REEL		396	3-701-443-21	WASHER, 5 DIA.	
366	A-2003-710-B	TABLE (T) ASSY, REEL		397	2-623-756-01	SCREW, (B1. 7X3), TAPPING	
367	3-578-224-00	WASHER		398	3-701-436-01	WASHER, 1. 6	
368	3-368-435-01	SPRING (FR LEVER), COMPRESSION		399	3-370-480-01	SPRING (BT), COMPRESSION	
369	X-3364-581-1	LEVER (F/R) ASSY		M903	X-3363-109-1	MOTOR ASSY (CAM)	
370	3-315-384-31	WASHER, STOPPER		M905	X-3363-110-1	MOTOR ASSY (REEL)	
375	3-368-421-01	GEAR (CAM DRIVE C)		PM902	1-454-536-11	SOLENOID, PLUNGER (BT CONTROL)	
376	3-373-039-01	GEAR (CAM DRIVE B)		PM903	1-454-535-11	SOLENOID, PLUNGER (BRAKE)	
377	3-368-403-01	GEAR (CAM DRIVE D)					

SECTION 6 ELECTRICAL PARTS LIST

NOTE:

The components identified by mark Δ or dotted line with mark Δ are critical for safety.
Replace only with part number specified.

Les composants identifiés par une marque Δ sont critiques pour la sécurité.
Ne les remplacer que par une pièce portant le numéro spécifié.

When indicating parts by reference number, please include the board name.

- Due to standardization, replacements in the parts list may be different from the parts specified in the diagrams or the components used on the set.
- -XX, -X mean standardized parts, so they may have some difference from the original one.
- RESISTORS
All resistors are in ohms
METAL : Metal-film resistor
METAL OXIDE : Metal Oxide-film resistor
F : nonflammable
- G : Germany model
- Items marked "*" are not stocked since they are seldom required for routine service. Some delay should be anticipated when ordering these items.
- SEMICONDUCTORS
In each case, u : μ , for example :
uA...: μ A..., uPA...: μ PA...,
uPB...: μ PB..., uPC...: μ PC...,
uPD...: μ PD...
- CAPACITORS
uF : μ F
- COILS

BALANCE VOL	CAM MOTOR	CAM SLIDER	CONTROL SW
--------------------	------------------	-------------------	-------------------

Ref. No.	Part No.	Description	Remarks	Ref. No.	Part No.	Description	Remarks
	* 1-639-326-11	BALANCE VOL BOARD *****			* A-2006-669-A	CONTROL SW BOARD, COMPLETE *****	
		< CONNECTOR >			9-911-839-XX	CUSHION	
CN102	* 1-564-507-11	PLUG, CONNECTOR 4P		* 4-922-523-01	HOLDER (RIGHT)		
		< RESISTOR >		* 4-922-524-01	HOLDER (LEFT)		
R101	1-259-462-11	CARBON 27K 5% 1/6W			< CAPACITOR >		
R201	1-259-462-11	CARBON 27K 5% 1/6W		C701	1-161-379-00	CERAMIC 0.01uF 20% 25V	
		< VARIABLE RESISTOR >		C702	1-161-379-00	CERAMIC 0.01uF 20% 25V	
RV101	1-238-687-11	RES, VAR, CARBON 50K/50K (BALANCE)		C703	1-124-584-00	ELECT 100uF 20% 10V	
		*****		C704	1-161-379-00	CERAMIC 0.01uF 20% 25V	
				C705	1-161-379-00	CERAMIC 0.01uF 20% 25V	
				C706	1-161-379-00	CERAMIC 0.01uF 20% 25V	
					< CONNECTOR >		
	* 1-639-303-11	CAM MOTOR BOARD *****		CN751	1-568-853-11	SOCKET, CONNECTOR 10P	
		< CAPACITOR >		CN752	1-568-849-11	SOCKET, CONNECTOR 6P	
C06	1-163-077-00	CERAMIC CHIP 0.1uF 10% 25V			< CIRCUIT BLOCK >		
		< MOTOR >		CP701	1-233-140-11	COMPOSITION CIRCUIT BLOCK 100k x 8	
M903	X-3363-109-1	MOTOR ASSY (CAM)		CP702	1-233-140-11	COMPOSITION CIRCUIT BLOCK 100k x 8	
		*****		CP703	1-233-140-11	COMPOSITION CIRCUIT BLOCK 100k x 8	
					< INDICATOR >		
	* 1-639-306-11	CAM SLIDER BOARD *****		FL701	1-519-672-11	INDICATOR TUBE, FLUORESCENT	
		< CHIP JUMPER >			< IC >		
JW04	1-216-296-00	METAL CHIP 0 5% 1/8W		IC701	8-752-818-86	IC CXP5058H-657Q	
JW05	1-216-296-00	METAL CHIP 0 5% 1/8W		IC702	8-759-995-09	IC MSM6338RS	
		< SWITCH >		IC703	8-752-330-59	IC CXK1011P	
SW1	1-570-953-11	SWITCH, PUSH (1 KEY) (STOP DET)			< TRANSISTOR >		
SW2	1-570-953-11	SWITCH, PUSH (1 KEY) (FWD DET)		Q701	8-729-119-78	TRANSISTOR 2SC2785-HFE	
		*****		Q702	8-729-119-78	TRANSISTOR 2SC2785-HFE	
				Q703	8-729-119-78	TRANSISTOR 2SC2785-HFE	
				Q704	8-729-119-78	TRANSISTOR 2SC2785-HFE	
				Q705	8-729-119-78	TRANSISTOR 2SC2785-HFE	
				Q706	8-729-119-78	TRANSISTOR 2SC2785-HFE	
				Q707	8-729-119-78	TRANSISTOR 2SC2785-HFE	

CONTROL SW

DRUM DRIVE

Ref. No.	Part No.	Description	Remarks
Q708	8-729-119-78	TRANSISTOR	2SC2785-HFE
Q709	8-729-119-78	TRANSISTOR	2SC2785-HFE
Q710	8-729-119-78	TRANSISTOR	2SC2785-HFE
(RESISTOR)			
R701	1-249-441-11	CARBON	100K 5% 1/4W
R702	1-249-441-11	CARBON	100K 5% 1/4W
R703	1-249-441-11	CARBON	100K 5% 1/4W
R704	1-249-441-11	CARBON	100K 5% 1/4W
R705	1-249-441-11	CARBON	100K 5% 1/4W
R706	1-249-441-11	CARBON	100K 5% 1/4W
R707	1-249-441-11	CARBON	100K 5% 1/4W
R708	1-249-441-11	CARBON	100K 5% 1/4W
R709	1-249-441-11	CARBON	100K 5% 1/4W
R710	1-249-441-11	CARBON	100K 5% 1/4W
R715	1-249-429-11	CARBON	10K 5% 1/4W
R716	1-249-422-11	CARBON	2. 7K 5% 1/4W
R720	1-249-429-11	CARBON	10K 5% 1/4W
R721	1-249-422-11	CARBON	2. 7K 5% 1/4W
R725	1-249-429-11	CARBON	10K 5% 1/4W
R726	1-249-422-11	CARBON	2. 7K 5% 1/4W
R730	1-249-429-11	CARBON	10K 5% 1/4W
R733	1-249-429-11	CARBON	10K 5% 1/4W
R734	1-249-422-11	CARBON	2. 7K 5% 1/4W
R735	1-249-424-11	CARBON	3. 9K 5% 1/4W
R736	1-249-429-11	CARBON	10K 5% 1/4W
R737	1-249-422-11	CARBON	2. 7K 5% 1/4W
R738	1-249-424-11	CARBON	3. 9K 5% 1/4W
R739	1-249-428-11	CARBON	8. 2K 5% 1/4W
R740	1-249-434-11	CARBON	27K 5% 1/4W
R741	1-249-429-11	CARBON	10K 5% 1/4W
R742	1-249-422-11	CARBON	2. 7K 5% 1/4W
R743	1-249-424-11	CARBON	3. 9K 5% 1/4W
R744	1-249-428-11	CARBON	8. 2K 5% 1/4W
R745	1-249-434-11	CARBON	27K 5% 1/4W
R746	1-249-429-11	CARBON	10K 5% 1/4W
R747	1-249-422-11	CARBON	2. 7K 5% 1/4W
R751	1-249-437-11	CARBON	47K 5% 1/4W
R752	1-249-437-11	CARBON	47K 5% 1/4W
R753	1-249-437-11	CARBON	47K 5% 1/4W
R754	1-249-437-11	CARBON	47K 5% 1/4W
R755	1-249-437-11	CARBON	47K 5% 1/4W
R756	1-249-437-11	CARBON	47K 5% 1/4W
R757	1-249-437-11	CARBON	47K 5% 1/4W
R758	1-249-437-11	CARBON	47K 5% 1/4W
R759	1-249-437-11	CARBON	47K 5% 1/4W
R760	1-249-437-11	CARBON	47K 5% 1/4W
R761	1-249-437-11	CARBON	47K 5% 1/4W
R762	1-249-437-11	CARBON	47K 5% 1/4W
R763	1-249-437-11	CARBON	47K 5% 1/4W
R764	1-249-437-11	CARBON	47K 5% 1/4W
R798	1-249-427-11	CARBON	6. 8K 5% 1/4W

Ref. No.	Part No.	Description	Remarks
(SWITCH)			
S705	1-554-937-11	SWITCH, KEY BOARD	(SKIP ID WRITE)
S706	1-554-937-11	SWITCH, KEY BOARD	(SKIP ID ERASE)
S710	1-554-937-11	SWITCH, KEY BOARD	(START ID WRITE)
S711	1-554-937-11	SWITCH, KEY BOARD	(START ID ERASE)
S715	1-554-937-11	SWITCH, KEY BOARD	(START ID AUTO)
S716	1-554-937-11	SWITCH, KEY BOARD	(START ID RENUMBER)
S724	1-554-937-11	SWITCH, KEY BOARD	(COUNTER RESET)
S725	1-554-937-11	SWITCH, KEY BOARD	(COUNTER MODE)
S726	1-554-937-11	SWITCH, KEY BOARD	(REW ◀◀)
S727	1-554-937-11	SWITCH, KEY BOARD	(FF ▶▶)
S728	1-554-937-11	SWITCH, KEY BOARD	(REC ○)
S729	1-554-937-11	SWITCH, KEY BOARD	(PAUSE ■■)
S730	1-554-937-11	SWITCH, KEY BOARD	(REC MUTE ●)
S731	1-554-937-11	SWITCH, KEY BOARD	(OPEN/CLOSE ⊕)
S732	1-554-937-11	SWITCH, KEY BOARD	(STOP ■)
S733	1-554-937-11	SWITCH, KEY BOARD	(PLAY ▶)
S734	1-554-937-11	SWITCH, KEY BOARD	(AMS ◀◀)
S735	1-554-937-11	SWITCH, KEY BOARD	(AMS ▶▶)
S736	1-554-937-11	SWITCH, KEY BOARD	(END ID WRITE)
S737	1-554-937-11	SWITCH, KEY BOARD	(END ID ERASE)
(CRYSTAL)			
X701	1-577-359-21	VIBRATOR, CERAMIC	(4.19MHz)

* A-2056-488-A DRUM DRIVE BOARD, COMPLETE			

* 3-343-491-01 HOLDER (S SENSOR B)			
4-870-539-00 PLATE, GROUND			
(CAPACITOR)			
C01	1-124-584-00	ELECT	100uF 20% 10V
C02	1-126-157-11	ELECT	10uF 20% 16V
C03	1-124-257-00	ELECT	2. 2uF 20% 50V
C04	1-163-013-11	CERAMIC CHIP	0. 0022uF 5% 50V
C05	1-163-013-11	CERAMIC CHIP	0. 0022uF 5% 50V
C08	1-163-001-11	CERAMIC CHIP	220PF 10% 50V
C21	1-163-001-11	CERAMIC CHIP	220PF 10% 50V
C31	1-163-001-11	CERAMIC CHIP	220PF 10% 50V
(CONNECTOR)			
CN01	* 1-564-704-11	PIN, CONNECTOR (SMALL TYPE)	2P
CN02	* 1-564-704-11	PIN, CONNECTOR (SMALL TYPE)	2P
CN03	* 1-564-338-00	PIN, CONNECTOR	4P
CN04	* 1-564-336-00	PIN, CONNECTOR	2P
CN05	* 1-564-336-61	PIN, CONNECTOR	2P
CN06	* 1-564-339-00	PIN, CONNECTOR	5P
CN07	1-564-721-11	PIN, CONNECTOR (SMALL TYPE)	5P
CN08	* 1-568-872-11	SOCKET, CONNECTOR	30P
CN09	* 1-564-706-11	PIN, CONNECTOR (SMALL TYPE)	4P

When indicating parts by reference number, please include the board name.

DRUM DRIVE

HEADPHONE

Ref. No.	Part No.	Description	Remarks
CN10	* 1-564-719-11	PIN, CONNECTOR (SMALL TYPE) 3P	
		< IC >	
IC01	8-759-107-68	IC CX20115A	
IC02	8-759-502-80	IC LM358M	
IC03	8-759-502-80	IC LM358M	
		< CHIP JUMPER >	
JW06	1-216-296-00	METAL CHIP 0 5% 1/8W	
JW07	1-216-296-00	METAL CHIP 0 5% 1/8W	
JW08	1-216-296-00	METAL CHIP 0 5% 1/8W	
JW09	1-216-296-00	METAL CHIP 0 5% 1/8W	
JW10	1-216-296-00	METAL CHIP 0 5% 1/8W	
JW11	1-216-296-00	METAL CHIP 0 5% 1/8W	
JW12	1-216-296-00	METAL CHIP 0 5% 1/8W	
JW13	1-216-296-00	METAL CHIP 0 5% 1/8W	
JW14	1-216-296-00	METAL CHIP 0 5% 1/8W	
JW15	1-216-296-00	METAL CHIP 0 5% 1/8W	
JW16	1-216-296-00	METAL CHIP 0 5% 1/8W	
JW17	1-216-296-00	METAL CHIP 0 5% 1/8W	
JW18	1-216-296-00	METAL CHIP 0 5% 1/8W	
JW19	1-216-296-00	METAL CHIP 0 5% 1/8W	
JW20	1-216-296-00	METAL CHIP 0 5% 1/8W	
JW21	1-216-296-00	METAL CHIP 0 5% 1/8W	
JW22	1-216-296-00	METAL CHIP 0 5% 1/8W	
JW23	1-216-296-00	METAL CHIP 0 5% 1/8W	
JW24	1-216-296-00	METAL CHIP 0 5% 1/8W	
JW25	1-216-296-00	METAL CHIP 0 5% 1/8W	
JW26	1-216-296-00	METAL CHIP 0 5% 1/8W	
JW27	1-216-296-00	METAL CHIP 0 5% 1/8W	
JW28	1-216-296-00	METAL CHIP 0 5% 1/8W	
JW29	1-216-296-00	METAL CHIP 0 5% 1/8W	
JW30	1-216-296-00	METAL CHIP 0 5% 1/8W	
		< PHOTO INTERRUPTER >	
PH01	8-719-939-23	DIODE GP-2S09-C	
PH02	8-719-939-23	DIODE GP-2S09-C	
		< TRANSISTOR >	
Q01	8-729-100-66	TRANSISTOR 2SC1623	
Q02	8-729-101-07	TRANSISTOR 2SB798-DL	
		< RESISTOR >	
R01	1-216-061-00	METAL CHIP 3.3K 5% 1/10W	
R02	1-216-075-00	METAL CHIP 12K 5% 1/10W	
R03	1-216-029-00	METAL CHIP 150 5% 1/10W	
R04	1-216-059-00	METAL CHIP 2.7K 5% 1/10W	
R05	1-216-057-00	METAL CHIP 2.2K 5% 1/10W	
R06	1-216-085-00	METAL CHIP 33K 5% 1/10W	
R07	1-216-025-00	METAL CHIP 100 5% 1/10W	
R08	1-216-049-00	METAL CHIP 1K 5% 1/10W	
R09	1-216-073-00	METAL CHIP 10K 5% 1/10W	

Ref. No.	Part No.	Description	Remarks
R10	1-216-073-00	METAL CHIP 10K 5% 1/10W	
R11	1-216-073-00	METAL CHIP 10K 5% 1/10W	
R12	1-216-089-00	METAL CHIP 47K 5% 1/10W	
R13	1-216-073-00	METAL CHIP 10K 5% 1/10W	
R14	1-216-037-00	METAL CHIP 330 5% 1/10W	
R21	1-216-073-00	METAL CHIP 10K 5% 1/10W	
R22	1-216-081-00	METAL CHIP 22K 5% 1/10W	
R23	1-216-077-00	METAL CHIP 15K 5% 1/10W	
R24	1-216-067-00	METAL CHIP 5.6K 5% 1/10W	
R25	1-216-103-00	METAL CHIP 180K 5% 1/10W	
R26	1-216-065-00	METAL CHIP 4.7K 5% 1/10W	
R31	1-216-073-00	METAL CHIP 10K 5% 1/10W	
R32	1-216-081-00	METAL CHIP 22K 5% 1/10W	
R35	1-216-103-00	METAL CHIP 180K 5% 1/10W	
R36	1-216-065-00	METAL CHIP 4.7K 5% 1/10W	

	* 1-639-327-11	HEADPHONE BOARD	

		< CAPACITOR >	
C180	1-162-290-31	CERAMIC 470PF 10% 50V	
C181	1-126-059-11	ELECT 10uF 20% 63V	
C280	1-162-290-31	CERAMIC 470PF 10% 50V	
C281	1-126-059-11	ELECT 10uF 20% 63V	
C451	1-126-024-11	ELECT 220uF 20% 25V	
C452	1-126-024-11	ELECT 220uF 20% 25V	
		< DIODE >	
D401	8-719-200-82	DIODE 11ES2	
D402	8-719-200-82	DIODE 11ES2	
		< IC >	
IC401	8-759-981-98	IC RC4560D-D	
		< JACK >	
J161	1-565-327-11	JACK, LARGE TYPE 1P (HEADPHONES)	
		< RESISTOR >	
R128	1-259-468-11	CARBON 47K 5% 1/6W	
R129	1-259-444-11	CARBON 4.7K 5% 1/6W	
R130	1-259-468-11	CARBON 47K 5% 1/6W	
R131	1-259-412-11	CARBON 220 5% 1/6W	
R228	1-259-468-11	CARBON 47K 5% 1/6W	
R229	1-259-444-11	CARBON 4.7K 5% 1/6W	
R230	1-259-468-11	CARBON 47K 5% 1/6W	
R231	1-259-412-11	CARBON 220 5% 1/6W	
R460	△ 1-212-857-00	FUSIBLE 10 5% 1/4W F	
R461	△ 1-212-857-00	FUSIBLE 10 5% 1/4W F	
		< VARIABLE RESISTOR >	
RV103	1-241-537-11	RES, VAR, CARBON 20K/20K (PHONES LEVEL)	

The components identified by mark △ or dotted line with mark △ are critical for safety. Replace only with part number specified.

Les composants identifiés par une marque △ sont critiques pour la sécurité. Ne les remplacer que par une pièce portant le numéro spécifié.

When indicating parts by reference number, please include the board name.

INPUT SW

MAIN

Ref. No.	Part No.	Description	Remarks	Ref. No.	Part No.	Description	Remarks
	* 1-639-328-11	INPUT SW BOARD *****		C303	1-162-211-31	CERAMIC	33PF 5% 50V
		< CONNECTOR >		C304	1-126-059-11	ELECT	10uF 20% 63V
CN772	* 1-564-336-00	PIN, CONNECTOR 2P < RESISTOR >		C305	1-136-153-00	FILM	0.01uF 5% 50V
R713	1-249-428-11	CARBON 8.2K 5% 1/4W		C306	1-164-159-11	CERAMIC	0.1uF 5% 50V
R714	1-249-434-11	CARBON 27K 5% 1/4W		C307	1-126-022-11	ELECT	47uF 20% 10V
		< SWITCH >		C309	1-124-983-11	ELECT	330uF 20% 6.3V
S702	1-572-758-11	SWITCH, ROTARY (INPUT)		C312	1-126-022-11	ELECT	47uF 20% 10V
		*****		C313	1-126-023-11	ELECT	100uF 20% 25V
	* A-2006-671-A	MAIN BOARD, COMPLETE *****		C314	1-162-199-31	CERAMIC	10PF 5% 50V
		< CAPACITOR >		C315	1-162-294-31	CERAMIC	0.001uF 10% 50V
C102	1-126-233-11	ELECT 22uF 20% 50V		C316	1-162-199-31	CERAMIC	10PF 5% 50V
C103	1-136-153-00	FILM 0.01uF 5% 50V		C317	1-162-201-31	CERAMIC	12PF 5% 50V
C104	1-136-165-00	FILM 0.1uF 5% 50V		C318	1-162-201-31	CERAMIC	12PF 5% 50V
C105	1-136-165-00	FILM 0.1uF 5% 50V		C319	1-164-159-11	CERAMIC	0.1uF 5% 50V
C106	1-136-153-00	FILM 0.01uF 5% 50V		C320	1-130-834-00	FILM	1uF 10% 63V
C110	1-136-439-11	FILM 330PF 5% 630V		C321	1-136-165-00	FILM	0.1uF 5% 50V
C111	1-136-439-11	FILM 330PF 5% 630V		C322	1-164-159-11	CERAMIC	0.1uF 5% 50V
C112	1-136-437-11	FILM 220PF 5% 630V		C323	1-162-206-31	CERAMIC	20PF 5% 50V
C113	1-136-437-11	FILM 220PF 5% 630V		C324	1-164-159-11	CERAMIC	0.1uF 5% 50V
C114	1-136-433-11	FILM 100PF 5% 630V		C325	1-126-022-11	ELECT	47uF 20% 10V
C115	1-136-433-11	FILM 100PF 5% 630V		C326	1-162-201-31	CERAMIC	12PF 5% 50V
C116	1-130-475-00	MYLAR 0.0022uF 5% 50V		C327	1-162-201-31	CERAMIC	12PF 5% 50V
C117	1-130-472-00	MYLAR 0.0012uF 5% 50V		C328	1-124-903-11	ELECT	1uF 20% 50V
C118	1-130-479-00	MYLAR 0.0047uF 5% 50V		C329	1-162-294-31	CERAMIC	0.001uF 10% 50V
C120	1-126-023-11	ELECT 100uF 20% 25V		C330	1-162-294-31	CERAMIC	0.001uF 10% 50V
C202	1-126-233-11	ELECT 22uF 20% 50V		C331	1-162-294-31	CERAMIC	0.001uF 10% 50V
C203	1-136-153-00	FILM 0.01uF 5% 50V		C332	1-136-153-00	FILM	0.01uF 5% 50V
C204	1-136-165-00	FILM 0.1uF 5% 50V		C333	1-130-473-00	MYLAR	0.0015uF 5% 50V
C205	1-136-165-00	FILM 0.1uF 5% 50V		C334	1-136-158-00	FILM	0.027uF 5% 50V
C206	1-136-153-00	FILM 0.01uF 5% 50V		C335	1-136-153-00	FILM	0.01uF 5% 50V
C210	1-136-439-11	FILM 330PF 5% 630V		C336	1-130-473-00	MYLAR	0.0015uF 5% 50V
C211	1-136-439-11	FILM 330PF 5% 630V		C337	1-136-158-00	FILM	0.027uF 5% 50V
C212	1-136-437-11	FILM 220PF 5% 630V		C338	1-162-306-11	CERAMIC	0.01uF 20% 16V
C213	1-136-437-11	FILM 220PF 5% 630V		C339	1-162-306-11	CERAMIC	0.01uF 20% 16V
C214	1-136-433-11	FILM 100PF 5% 630V		C340	1-162-290-31	CERAMIC	470PF 10% 50V
C215	1-136-433-11	FILM 100PF 5% 630V		C341	1-162-306-11	CERAMIC	0.01uF 20% 16V
C216	1-130-475-00	MYLAR 0.0022uF 5% 50V		C342	1-126-059-11	ELECT	10uF 20% 63V
C217	1-130-472-00	MYLAR 0.0012uF 5% 50V		C343	1-162-306-11	CERAMIC	0.01uF 20% 16V
C218	1-130-479-00	MYLAR 0.0047uF 5% 50V		C344	1-162-306-11	CERAMIC	0.01uF 20% 16V
C220	1-126-023-11	ELECT 100uF 20% 25V		C347	1-162-294-31	CERAMIC	0.001uF 10% 50V
C300	1-162-294-31	CERAMIC 0.001uF 10% 50V		C348	1-126-059-11	ELECT	10uF 20% 63V
C301	1-130-834-00	FILM 1uF 10% 63V		C362	1-126-043-11	ELECT	0.47uF 20% 50V
C302	1-164-159-11	CERAMIC 0.1uF 50V		C363	1-126-059-11	ELECT	10uF 20% 63V
				C401	1-136-165-00	FILM	0.1uF 5% 50V
				C402	1-136-165-00	FILM	0.1uF 5% 50V
				C405	1-136-165-00	FILM	0.1uF 5% 50V
				C406	1-126-058-11	ELECT	4.7uF 20% 63V
				C407	1-136-165-00	FILM	0.1uF 5% 50V
				C408	1-136-165-00	FILM	0.1uF 5% 50V
				C409	1-126-104-11	ELECT	470uF 20% 35V
				C410	1-136-165-00	FILM	0.1uF 5% 50V
				C411	1-126-104-11	ELECT	470uF 20% 35V

When indicating parts by reference number, please include the board name.

MAIN

Ref. No.	Part No.	Description	Remarks	Ref. No.	Part No.	Description	Remarks
C412	1-136-165-00	FILM	0.1uF 5%	50V	C512	1-164-159-11 CERAMIC	0.1uF 50V
C413	1-126-104-11	ELECT	470uF 20%	35V	C513	1-126-023-11 ELECT	100uF 20% 25V
C414	1-126-104-11	ELECT	470uF 20%	35V	C514	1-136-165-00 FILM	0.1uF 5% 50V
C415	1-136-165-00	FILM	0.1uF 5%	50V	C515	1-136-169-00 FILM	0.22uF 5% 50V
C416	1-136-165-00	FILM	0.1uF 5%	50V	C516	1-136-165-00 FILM	0.1uF 5% 50V
C417	1-164-159-11	CERAMIC	0.1uF	50V	C517	1-164-159-11 CERAMIC	0.1uF 50V
C418	1-136-165-00	FILM	0.1uF 5%	50V			
C419	1-136-165-00	FILM	0.1uF 5%	50V		< CONNECTOR >	
C420	1-136-165-00	FILM	0.1uF 5%	50V	CN104	* 1-564-507-11 PLUG, CONNECTOR 4P	
C421	1-136-165-00	FILM	0.1uF 5%	50V	CN107	* 1-564-509-11 PLUG, CONNECTOR 6P	
C422	1-126-023-11	ELECT	100uF 20%	25V	CN301	* 1-564-706-11 PIN, CONNECTOR (SMALL TYPE) 4P	
C423	1-126-023-11	ELECT	100uF 20%	25V	CN308	* 1-564-339-00 PIN, CONNECTOR 5P	
C425	1-126-104-11	ELECT	470uF 20%	35V	CN333	* 1-564-514-11 PLUG, CONNECTOR 11P	
C426	1-136-165-00	FILM	0.1uF 5%	50V	CN501	* 1-564-716-11 PIN, CONNECTOR (SMALL TYPE) 14P	
C427	1-136-165-00	FILM	0.1uF 5%	50V	CN508	* 1-568-933-11 SOCKET, CONNECTOR 30P	
C428	1-136-165-00	FILM	0.1uF 5%	50V	CN571	* 1-568-829-11 SOCKET, CONNECTOR 10P	
C429	1-136-165-00	FILM	0.1uF 5%	50V	CN572	* 1-568-825-11 SOCKET, CONNECTOR 6P	
C430	1-126-059-11	ELECT	10uF 20%	63V			< DIODE >
C431	1-126-059-11	ELECT	10uF 20%	63V	D101	8-719-107-94 DIODE 1SS202-1	
C432	1-124-273-00	ELECT	3.3uF 20%	50V	D102	8-719-107-94 DIODE 1SS202-1	
C435	1-126-023-11	ELECT	100uF 20%	25V	D201	8-719-107-94 DIODE 1SS202-1	
C436	1-126-023-11	ELECT	100uF 20%	25V	D202	8-719-107-94 DIODE 1SS202-1	
C437	1-124-983-11	ELECT	330uF 20%	6.3V	D306	8-719-200-82 DIODE 11ES2	
C438	1-124-983-11	ELECT	330uF 20%	6.3V	D307	8-719-107-94 DIODE 1SS202-1	
C439	1-164-159-11	CERAMIC	0.1uF	50V	D308	8-719-107-94 DIODE 1SS202-1	
C440	1-124-983-11	ELECT	330uF 20%	6.3V	D314	8-719-200-82 DIODE 11ES2	
C441	1-164-159-11	CERAMIC	0.1uF	50V	D323	8-719-107-94 DIODE 1SS202-1	
C442	1-164-159-11	CERAMIC	0.1uF	50V	D350	8-719-107-94 DIODE 1SS202-1	
C444	1-164-159-11	CERAMIC	0.1uF	50V	D403	8-719-107-94 DIODE 1SS202-1	
C446	1-164-159-11	CERAMIC	0.1uF	50V	D404	8-719-210-21 DIODE 11EQS04	
C447	1-164-159-11	CERAMIC	0.1uF	50V	D501	8-719-918-45 DIODE KV1310	
C448	1-164-159-11	CERAMIC	0.1uF	50V	D503	8-719-903-27 DIODE 1SS168	
C449	1-164-159-11	CERAMIC	0.1uF	50V			< INDUCTOR >
C450	1-136-165-00	FILM	0.1uF 5%	50V	FB301	1-410-397-21 FRRITE BEAD	
C451	1-136-165-00	FILM	0.1uF 5%	50V			< IC >
C460	1-164-159-11	CERAMIC	0.1uF	50V	IC101	8-759-602-83 IC M5238P	
C461	1-164-159-11	CERAMIC	0.1uF	50V	IC201	8-759-602-83 IC M5238P	
C462	1-164-159-11	CERAMIC	0.1uF	50V	IC301	8-759-917-18 IC SN74HCU04N	
C470	1-164-159-11	CERAMIC	0.1uF	50V	IC302	8-759-232-01 IC TC74HCO0AP	
C471	1-164-159-11	CERAMIC	0.1uF	50V	IC303	8-759-917-18 IC SN74HCU04N	
C472	1-164-159-11	CERAMIC	0.1uF	50V	IC304	8-759-135-80 IC uPC358C	
C473	1-164-159-11	CERAMIC	0.1uF	50V	IC307	8-752-339-43 IC CXD2601AQ	
C499	1-162-290-31	CERAMIC	470PF 10%	50V	IC308	8-759-906-24 IC SN74LS624N	
C501	1-136-165-00	FILM	0.1uF 5%	50V	IC310	8-752-337-80 IC CXK58257AM-12L	
C503	1-162-199-31	CERAMIC	10PF 5%	50V	IC311	8-752-832-76 IC CXP80524-046Q	
C504	1-126-023-11	ELECT	100uF 20%	25V	IC312	8-752-833-31 IC CXP80524-048Q	
C505	1-162-211-31	CERAMIC	33PF 5%	50V	IC316	8-759-135-80 IC uPC358C	
C506	1-162-199-31	CERAMIC	10PF 5%	50V	IC317	8-759-135-80 IC uPC358C	
C507	1-136-153-00	FILM	0.01uF 5%	50V	IC318	8-759-135-80 IC uPC358C	
C508	1-136-158-00	FILM	0.027uF 5%	50V			
C509	1-126-023-11	ELECT	100uF 20%	25V			
C511	1-136-165-00	FILM	0.1uF 5%	50V			

When indicating parts by reference number, please include the board name.

MAIN

Ref. No.	Part No.	Description	Remarks	Ref. No.	Part No.	Description	Remarks
IC319	8-759-633-65	IC M54641L		Q321	8-729-927-12	TRANSISTOR	2SC4115S-QR
IC320	8-759-633-65	IC M54641L		Q333	8-729-924-90	TRANSISTOR	2SB1370-EF
IC321	8-759-971-12	IC PST529E		Q334	8-729-920-68	TRANSISTOR	2SA933S-QR
IC322	8-759-231-53	IC M5F7805L		Q335	8-729-119-78	TRANSISTOR	2SC2785-HFE
IC331	8-749-921-11	IC GP1F32R		Q336	8-729-927-11	TRANSISTOR	2SA1585S-QR
IC332	8-749-921-12	IC GP1F32T		Q337	8-729-927-11	TRANSISTOR	2SA1585S-QR
IC333	8-759-917-18	IC SN74HCU04N		Q338	8-729-927-12	TRANSISTOR	2SC4115S-QR
IC354	8-759-900-72	IC NE5532P		Q339	8-729-927-12	TRANSISTOR	2SC4115S-QR
IC355	8-759-900-72	IC NE5532P		Q340	8-729-119-78	TRANSISTOR	2SC2785-HFE
IC356	8-759-945-58	IC RC4558P		Q341	8-729-119-78	TRANSISTOR	2SC2785-HFE
IC357	8-759-231-53	IC M5F7805L		Q342	8-729-209-15	TRANSISTOR	2SD2012
IC358	8-759-245-79	IC M5F7905L		Q343	8-729-920-68	TRANSISTOR	2SA933S-QR
IC359	8-759-504-36	IC AK5339		Q432	8-729-900-80	TRANSISTOR	DTC114ES
IC360	8-759-504-50	IC LF412CN/SL161841		Q433	8-729-107-85	TRANSISTOR	2SC3623A-K
IC362	8-752-344-10	IC CXD2561M-1		Q434	8-729-107-85	TRANSISTOR	2SC3623A-K
IC363	8-752-342-65	IC CXD2560M		Q435	8-729-900-61	TRANSISTOR	DTA114ES
IC374	8-759-634-55	IC M5F7805L-720		Q436	8-729-900-80	TRANSISTOR	DTC114ES
IC375	8-759-900-72	IC NE5532P		Q437	8-729-900-61	TRANSISTOR	DTA114ES
IC376	8-759-900-72	IC NE5532P		Q438	8-729-900-80	TRANSISTOR	DTC114ES
IC431	8-759-925-78	IC SN74HC10NS		Q439	8-729-900-80	TRANSISTOR	DTC114ES
IC432	8-759-995-76	IC PST529C		Q440	8-729-119-78	TRANSISTOR	2SC2785-HFE
IC501	8-759-604-30	IC M5F7808		Q499	8-729-900-80	TRANSISTOR	DTC114ES
IC502	8-759-233-64	IC TC74HCU04AF		Q501	8-729-200-56	TRANSISTOR	2SK241-GR
IC503	8-759-242-57	IC TC74HC4020AF		Q502	8-729-200-56	TRANSISTOR	2SK241-GR
IC504	8-759-250-81	IC TC5081AP		Q503	8-729-900-61	TRANSISTOR	DTA114ES
< JACK >				< RESISTOR >			
J101	1-568-751-61	JACK, PIN (2P SHIELD TYPE) (LINE IN)		R102	1-247-903-00	CARBON	1M 5% 1/4W
J102	1-568-751-61	JACK, PIN (2P SHIELD TYPE) (LINE OUT)		R103	1-249-417-11	CARBON	1K 5% 1/4W
J191	1-568-750-21	JACK, PIN (1P SHIELD TYPE) (DIGITAL IN COAXIAL)		R104	1-249-433-11	CARBON	22K 5% 1/4W
< COIL >				R105	1-249-435-11	CARBON	33K 5% 1/4W
L301	1-410-509-11	INDUCTOR	10 μ H	R106	1-249-403-11	CARBON	68 5% 1/4W
L302	1-410-498-11	INDUCTOR	1.2 μ H	R107	1-247-854-11	CARBON	9.1K 5% 1/4W
L303	1-410-509-11	INDUCTOR	10 μ H	R108	1-247-854-11	CARBON	9.1K 5% 1/4W
L305	1-410-515-11	INDUCTOR	33 μ H	R109	1-247-854-11	CARBON	9.1K 5% 1/4W
L306	1-410-509-11	INDUCTOR	10 μ H	R110	1-247-854-11	CARBON	9.1K 5% 1/4W
L501	1-424-604-11	COIL	1.6 μ H	R111	1-249-425-11	CARBON	4.7K 5% 1/4W
L502	1-410-324-11	INDUCTOR	4.7 μ H	R112	1-249-425-11	CARBON	4.7K 5% 1/4W
L503	1-410-324-11	INDUCTOR	4.7 μ H	R113	1-249-425-11	CARBON	4.7K 5% 1/4W
L504	1-410-324-11	INDUCTOR	4.7 μ H	R114	1-249-425-11	CARBON	4.7K 5% 1/4W
L505	1-424-604-11	COIL	1.6 μ H	R115	1-249-430-11	CARBON	12K 5% 1/4W
< TRANSISTOR >				R116	1-249-430-11	CARBON	12K 5% 1/4W
Q301	8-729-927-11	TRANSISTOR	2SA1585S-QR	R117	1-249-426-11	CARBON	5.6K 5% 1/4W
Q302	8-729-801-93	TRANSISTOR	2SD1387	R118	1-249-426-11	CARBON	5.6K 5% 1/4W
Q311	8-729-900-80	TRANSISTOR	DTC114ES	R119	1-249-426-11	CARBON	5.6K 5% 1/4W
Q312	8-729-107-85	TRANSISTOR	2SC3623A-K	R120	1-249-426-11	CARBON	5.6K 5% 1/4W
Q313	8-729-900-61	TRANSISTOR	DTA114ES	R121	1-249-405-11	CARBON	100 5% 1/4W
Q318	8-729-900-80	TRANSISTOR	DTC114ES	R122	1-249-419-11	CARBON	1.5K 5% 1/4W
Q319	8-729-900-80	TRANSISTOR	DTC114ES	R123	1-249-419-11	CARBON	1.5K 5% 1/4W
Q320	8-729-927-11	TRANSISTOR	2SA1585S-QR	R124	1-249-441-11	CARBON	100K 5% 1/4W
				R125	1-249-409-11	CARBON	220 5% 1/4W
				R126	1-249-429-11	CARBON	10K 5% 1/4W
				R127	1-249-405-11	CARBON	100 5% 1/4W

When indicating parts by reference number, please include the board name.

MAIN

Ref. No.	Part No.	Description	Quantity	Unit	Remarks	Ref. No.	Part No.	Description	Quantity	Unit	Remarks
R150	1-249-433-11	CARBON	22K	5%	1/4W	R320	1-247-804-11	CARBON	75	5%	1/4W
R151	1-259-882-11	CARBON	3. 3M	5%	1/4W	R321	1-249-405-11	CARBON	100	5%	1/4W
R152	1-259-882-11	CARBON	3. 3M	5%	1/4W	R322	1-249-429-11	CARBON	10K	5%	1/4W
R153	1-247-806-11	CARBON	91	5%	1/4W	R323	1-249-433-11	CARBON	22K	5%	1/4W
R180	1-249-397-11	CARBON	22	5%	1/4W	R324	1-249-433-11	CARBON	22K	5%	1/4W
R202	1-247-903-00	CARBON	1M	5%	1/4W	R325	1-249-425-11	CARBON	4. 7K	5%	1/4W
R203	1-249-417-11	CARBON	1K	5%	1/4W	R326	1-249-409-11	CARBON	220	5%	1/4W
R204	1-249-433-11	CARBON	22K	5%	1/4W	R327	1-249-425-11	CARBON	4. 7K	5%	1/4W
R205	1-249-435-11	CARBON	33K	5%	1/4W	R328	1-249-417-11	CARBON	1K	5%	1/4W
R206	1-249-403-11	CARBON	68	5%	1/4W	R329	1-249-413-11	CARBON	470	5%	1/4W
R207	1-247-854-11	CARBON	9. 1K	5%	1/4W	R330	1-249-417-11	CARBON	1K	5%	1/4W
R208	1-247-854-11	CARBON	9. 1K	5%	1/4W	R331	1-249-429-11	CARBON	10K	5%	1/4W
R209	1-247-854-11	CARBON	9. 1K	5%	1/4W	R332	1-249-429-11	CARBON	10K	5%	1/4W
R210	1-247-854-11	CARBON	9. 1K	5%	1/4W	R333	1-249-433-11	CARBON	22K	5%	1/4W
R211	1-249-425-11	CARBON	4. 7K	5%	1/4W	R334	1-249-425-11	CARBON	4. 7K	5%	1/4W
R212	1-249-425-11	CARBON	4. 7K	5%	1/4W	R335	1-249-425-11	CARBON	4. 7K	5%	1/4W
R213	1-249-425-11	CARBON	4. 7K	5%	1/4W	R336	1-249-425-11	CARBON	4. 7K	5%	1/4W
R214	1-249-425-11	CARBON	4. 7K	5%	1/4W	R337	1-249-429-11	CARBON	10K	5%	1/4W
R215	1-249-430-11	CARBON	12K	5%	1/4W	R338	1-249-433-11	CARBON	22K	5%	1/4W
R216	1-249-430-11	CARBON	12K	5%	1/4W	R339	1-249-401-11	CARBON	47	5%	1/4W
R217	1-249-426-11	CARBON	5. 6K	5%	1/4W	R340	1-249-429-11	CARBON	10K	5%	1/4W
R218	1-249-426-11	CARBON	5. 6K	5%	1/4W	R341	1-249-429-11	CARBON	10K	5%	1/4W
R219	1-249-426-11	CARBON	5. 6K	5%	1/4W	R342	1-249-429-11	CARBON	10K	5%	1/4W
R220	1-249-426-11	CARBON	5. 6K	5%	1/4W	R343	1-249-438-11	CARBON	56K	5%	1/4W
R221	1-249-405-11	CARBON	100	5%	1/4W	R344	1-249-438-11	CARBON	56K	5%	1/4W
R222	1-249-419-11	CARBON	1. 5K	5%	1/4W	R345	1-249-438-11	CARBON	56K	5%	1/4W
R223	1-249-419-11	CARBON	1. 5K	5%	1/4W	R346	1-249-441-11	CARBON	100K	5%	1/4W
R224	1-249-441-11	CARBON	100K	5%	1/4W	R347	1-249-441-11	CARBON	100K	5%	1/4W
R225	1-249-409-11	CARBON	220	5%	1/4W	R348	1-249-441-11	CARBON	100K	5%	1/4W
R226	1-249-429-11	CARBON	10K	5%	1/4W	R349	1-249-441-11	CARBON	100K	5%	1/4W
R227	1-249-405-11	CARBON	100	5%	1/4W	R350	1-249-425-11	CARBON	4. 7K	5%	1/4W
R250	1-249-433-11	CARBON	22K	5%	1/4W	R351	1-249-425-11	CARBON	4. 7K	5%	1/4W
R251	1-259-882-11	CARBON	3. 3M	5%	1/4W	R352	1-249-441-11	CARBON	100K	5%	1/4W
R252	1-259-882-11	CARBON	3. 3M	5%	1/4W	R353	1-249-441-11	CARBON	100K	5%	1/4W
R253	1-247-806-11	CARBON	91	5%	1/4W	R354	1-249-441-11	CARBON	100K	5%	1/4W
R280	1-249-397-11	CARBON	22	5%	1/4W	R355	1-249-417-11	CARBON	1K	5%	1/4W
R301	1-247-804-11	CARBON	75	5%	1/4W	R356	1-249-417-11	CARBON	1K	5%	1/4W
R302	1-249-437-11	CARBON	47K	5%	1/4W	R357	1-249-405-11	CARBON	100	5%	1/4W
R303	1-249-421-11	CARBON	2. 2K	5%	1/4W	R358	1-249-417-11	CARBON	1K	5%	1/4W
R304	1-249-441-11	CARBON	100K	5%	1/4W	R359	1-249-408-11	CARBON	180	5%	1/4W
R305	1-249-421-11	CARBON	2. 2K	5%	1/4W	R360	1-249-437-11	CARBON	47K	5%	1/4W
R306	1-249-417-11	CARBON	1K	5%	1/4W	R361	1-249-437-11	CARBON	47K	5%	1/4W
R307	1-249-417-11	CARBON	1K	5%	1/4W	R365	1-249-425-11	CARBON	4. 7K	5%	1/4W
R308	1-249-425-11	CARBON	4. 7K	5%	1/4W	R366	1-249-441-11	CARBON	100K	5%	1/4W
R309	1-249-421-11	CARBON	2. 2K	5%	1/4W	R367	1-249-417-11	CARBON	1K	5%	1/4W
R310	1-249-441-11	CARBON	100K	5%	1/4W	R368	1-249-417-11	CARBON	1K	5%	1/4W
R311	1-249-429-11	CARBON	10K	5%	1/4W	R369	1-249-405-11	CARBON	100	5%	1/4W
R312	1-249-421-11	CARBON	2. 2K	5%	1/4W	R370	1-249-405-11	CARBON	100	5%	1/4W
R313	1-249-421-11	CARBON	2. 2K	5%	1/4W	R371	1-249-417-11	CARBON	1K	5%	1/4W
R314	1-249-435-11	CARBON	33K	5%	1/4W	R372	1-249-405-11	CARBON	100	5%	1/4W
R315	1-249-429-11	CARBON	10K	5%	1/4W	R373	1-249-417-11	CARBON	1K	5%	1/4W
R319	1-249-409-11	CARBON	220	5%	1/4W	R374	1-249-417-11	CARBON	1K	5%	1/4W

When indicating parts by reference number, please include the board name.

MOTOR **POWER** **RELAY** **PRIMARY**

Ref. No.	Part No.	Description	Remarks	Ref. No.	Part No.	Description	Remarks
	* 1-639-646-11	MOTOR BOARD *****		D905	8-719-312-47	DIODE RBA-406B	
		< CAPACITOR >		D906	8-719-107-94	DIODE 1SS202-1	
C01	1-162-851-11	CERAMIC 0.1MF	16V	D907	8-719-200-82	DIODE 11ES2	
		< CONNECTOR >		D908	8-719-200-82	DIODE 11ES2	
CN01	* 1-564-336-00	PIN, CONNECTOR 2P		D909	8-719-934-15	DIODE HZS24-3L	
CN02	* 1-564-336-61	PIN, CONNECTOR 2P		D910	8-719-933-33	DIODE HZS6A1L	
CN03	* 1-564-498-11	PIN, CONNECTOR 5P		D911	8-719-200-77	DIODE 10E2N	
		< MOTOR >		D912	8-719-200-77	DIODE 10E2N	
M901	A-2003-448-A	MOTOR ASSY (CASSETTE COMPARTMENT)		D913	8-719-200-77	DIODE 10E2N	
		*****		D914	8-719-200-77	DIODE 10E2N	
	* A-2006-670-A	POWER BOARD, COMPLETE *****		D915	8-719-107-94	DIODE 1SS202-1	
	△ * 1-533-213-31	HOLDER, FUSE		D916	8-719-107-94	DIODE 1SS202-1	
	7-682-147-15	SCREW, TR				< FUSE >	
		< CAPACITOR >		F901	△ 1-532-286-00	FUSE, TIME-LAG (T2. 5A) (AEP, G)	
C907	1-126-946-11	ELECT 6800uF	20% 25V	F901	△ 1-532-744-11	FUSE, GLASS TUBE (2. 5A) (US, Canadian)	
C908	1-164-159-11	CERAMIC 0.1uF	50V			< IC >	
C909	1-124-473-11	ELECT 1000uF	20% 10V	IC901	8-759-148-79	IC uPC2406HF	
C910	1-164-159-11	CERAMIC 0.1uF	50V	IC902	8-759-231-53	IC M5F7805L	
C911	1-164-159-11	CERAMIC 0.1uF	50V	IC903	8-759-231-58	IC M5F7812L	
C912	1-124-473-11	ELECT 1000uF	20% 10V	IC904	8-759-245-86	IC TA7912S	
C913	1-126-104-11	ELECT 470uF	20% 35V			< TRANSISTOR >	
C914	1-126-104-11	ELECT 470uF	20% 35V	Q901	8-729-140-97	TRANSISTOR 2SB734-34	
C915	1-126-049-11	ELECT 22uF	20% 50V			< RESISTOR >	
C916	1-126-052-11	ELECT 100uF	20% 50V	R901	1-249-425-11	CARBON 4.7K 5% 1/4W	
C917	1-136-165-00	FILM 0.1uF	5% 50V	R902	△ 1-212-849-00	FUSIBLE 4.7 5% 1/4W F	
C918	1-130-834-00	FILM 1uF	10% 63V	R903	1-249-421-11	CARBON 2.2K 5% 1/4W	
C919	1-136-165-00	FILM 0.1uF	5% 50V	R904	△ 1-212-865-00	FUSIBLE 22 5% 1/4W F	
C920	1-128-468-51	ELECT 4700uF	25V	R905	1-249-433-11	CARBON 22K 5% 1/4W	
C921	1-128-468-51	ELECT 4700uF	25V			*****	
C922	1-164-159-11	CERAMIC 0.1uF	50V			* 1-639-332-11	RELAY BOARD
C923	1-164-159-11	CERAMIC 0.1uF	50V			*****	
C924	1-164-159-11	CERAMIC 0.1uF	50V			* 1-639-333-11	PRIMARY BOARD
C925	1-164-159-11	CERAMIC 0.1uF	50V			*****	
C926	1-126-105-11	ELECT 1000uF	20% 35V			* 3-346-266-12	PLATE, GROUND
C927	1-126-105-11	ELECT 1000uF	20% 35V				< CAPACITOR >
		< CONNECTOR >		C901	△ 1-161-744-00	CERAMIC 0.01uF	400V
CN905	* 1-560-338-00	PIN, CONNECTOR 7P		C902	△ 1-161-742-00	CERAMIC 0.0022uF	20% 400V
CN906	* 1-560-061-00	PIN, CONNECTOR 3P		C903	△ 1-161-742-00	CERAMIC 0.0022uF	20% 400V
CN931	* 1-564-505-11	PLUG, CONNECTOR 2P		C904	△ 1-161-742-00	CERAMIC 0.0022uF	20% 400V
CN932	* 1-564-511-11	PLUG, CONNECTOR 8P		C905	△ 1-161-742-00	CERAMIC 0.0022uF	20% 400V (AEP, G)
CN933	* 1-564-506-11	PLUG, CONNECTOR 3P		C906	△ 1-161-744-00	CERAMIC 0.01uF	400V
		< DIODE >				*****	

The components identified by mark △ or dotted line with mark △ are critical for safety. Replace only with part number specified.	Les composants identifiés par une marque △ sont critiques pour la sécurité. Ne les remplacer que par une pièce portant le numéro spécifié.	When indicating parts by reference number, please include the board name.
---	---	---

PRIMARY

REC VOL

REEL MOTOR

RF AMP

RGN SW

Ref. No.	Part No.	Description	Remarks	Ref. No.	Part No.	Description	Remarks
		< CONNECTOR >					
CN901	* 1-564-321-00	PIN, CONNECTOR 2P		C22	1-126-603-11	ELECT CHIP 4.7uF	20% 35V
CN902	1-564-321-00	PIN, CONNECTOR 2P		C23	1-163-117-00	CERAMIC CHIP 100PF	5% 50V
		< COIL >		C24	1-163-038-00	CERAMIC CHIP 0.1uF	25V
L901	△ 1-421-915-11	COIL, LINE FILTER		C25	1-124-778-00	ELECT CHIP 22uF	20% 6.3V
		*****		C26	1-163-038-00	CERAMIC CHIP 0.1uF	25V
	* 1-639-325-11	REC VOL BOARD				< CONNECTOR >	
		*****		CN51	* 1-566-207-11	PIN, CONNECTOR (PC BOARD) 14P	
		< VARIABLE RESISTOR >		CN52	* 1-564-720-11	PIN, CONNECTOR (SMALL TYPE) 4P	
RV102	1-238-833-21	RES, VAR, CARBON 20K/20K (REC LEVEL)				< IC >	
		*****		IC1	8-752-039-01	IC CXA1364R	
	* 1-639-304-11	REEL MOTOR BOARD				< COIL >	
		*****		L1	1-408-781-00	INDUCTOR CHIP 22uH	
		< CAPACITOR >		L2	1-408-789-21	INDUCTOR, CHIP 100uH	
C07	1-163-077-00	CERAMIC CHIP 0.1uF	10% 25V	L3	1-408-781-00	INDUCTOR CHIP 22uH	
		< MOTOR >				< RESISTOR >	
M905	X-3363-110-1	MOTOR ASSY (REEL)		R1	1-216-082-00	METAL GLAZE 24K 5%	1/10W
		*****		R2	1-216-082-00	METAL GLAZE 24K 5%	1/10W
		RF AMP BOARD, COMPLETE		R3	1-216-066-00	METAL CHIP 5.1K 5%	1/10W
		*****		R4	1-216-066-00	METAL CHIP 5.1K 5%	1/10W
		< CAPACITOR >		R5	1-216-077-00	METAL CHIP 15K 5%	1/10W
C1	1-124-778-00	ELECT CHIP 22uF	20% 6.3V	R6	1-216-077-00	METAL CHIP 15K 5%	1/10W
C2	1-163-019-00	CERAMIC CHIP 0.0068uF	10% 50V	R7	1-216-077-00	METAL CHIP 15K 5%	1/10W
C3	1-163-117-00	CERAMIC CHIP 100PF	5% 50V	R8	1-216-079-00	METAL CHIP 18K 5%	1/10W
C4	1-162-638-11	CERAMIC CHIP 1uF	16V	R9	1-216-075-00	METAL CHIP 12K 5%	1/10W
C5	1-164-299-11	CERAMIC CHIP 0.22uF	10% 25V	R10	1-216-079-00	METAL CHIP 18K 5%	1/10W
C6	1-164-004-11	CERAMIC CHIP 0.1uF	10% 25V	R11	1-216-077-00	METAL CHIP 15K 5%	1/10W
C7	1-163-009-11	CERAMIC CHIP 0.001uF	10% 50V	R12	1-216-077-00	METAL CHIP 15K 5%	1/10W
C8	1-124-778-00	ELECT CHIP 22uF	20% 6.3V	R13	1-216-077-00	METAL CHIP 15K 5%	1/10W
C9	1-124-778-00	ELECT CHIP 22uF	20% 6.3V	R14	1-216-081-00	METAL CHIP 22K 5%	1/10W
C10	1-163-009-11	CERAMIC CHIP 0.001uF	10% 50V	R15	1-216-085-00	METAL CHIP 33K 5%	1/10W
C11	1-164-004-11	CERAMIC CHIP 0.1uF	10% 25V	R16	1-216-089-00	METAL CHIP 47K 5%	1/10W
C12	1-164-299-11	CERAMIC CHIP 0.22uF	10% 25V	R17	1-216-080-00	METAL CHIP 20K 5%	1/10W
C13	1-162-638-11	CERAMIC CHIP 1uF	16V	R18	1-216-073-00	METAL CHIP 10K 5%	1/10W
C14	1-163-117-00	CERAMIC CHIP 100PF	5% 50V			< VARIABLE RESISTOR >	
C15	1-124-778-00	ELECT CHIP 22uF	20% 6.3V	RV1	1-238-181-11	RES, ADJ, CERMET 4.7K	
C16	1-163-038-00	CERAMIC CHIP 0.1uF	25V	RV2	1-238-181-11	RES, ADJ, CERMET 4.7K	
C17	1-163-001-11	CERAMIC CHIP 220PF	10% 50V			*****	
C18	1-163-117-00	CERAMIC CHIP 100PF	5% 50V			* 1-639-301-11	RGN SW BOARD
C19	1-163-001-11	CERAMIC CHIP 220PF	10% 50V			*****	
C20	1-164-182-11	CERAMIC CHIP 0.0033uF	10% 50V			< SWITCH >	
C21	1-163-005-11	CERAMIC CHIP 470PF	10% 50V	S01	1-571-878-11	SWITCH, PUSH (2 KEY)	(CASSETTE IN/REC PROOF)

The components identified by mark △ or dotted line with mark △ are critical for safety. Replace only with part number specified.

Les composants identifiés par une marque △ sont critiques pour la sécurité. Ne les remplacer que par une pièce portant le numéro spécifié.

When indicating parts by reference number, please include the board name.

SW (IN)

SW (OUT)

TIMER SW

TOP END SENSOR

Ref. No.	Part No.	Description	Remarks	Ref. No.	Part No.	Description	Remarks
	* 1-639-647-11	SW (IN) BOARD ***** < SWITCH >				MISCELLANEOUS *****	
S11	1-572-247-11	SWITCH, SLIDE (CASSETTE TABLE IN)		10	△ 1-575-695-11	CORD, POWER (US, Canadian)	
*****				10	△ 1-575-912-11	CORD, POWER (AEP, G)	
	* 1-639-648-11	SW (OUT) BOARD ***** < SWITCH >		62	1-590-321-71	LEAD (WITH CONNECTOR)	
S12	1-570-975-11	SWITCH, SLIDE (CASSETTE TABLE OUT)		109	1-590-915-11	WIRE, FLAT TYPE (30 CORE)	
*****				110	1-590-916-11	WIRE, FLAT TYPE (10 CORE)	
	* 1-639-329-11	TIMER SW BOARD ***** < IC >		111	1-590-914-11	WIRE, FLAT TYPE (6 CORE)	
IC704	8-749-922-36	IC GP1U50XB < RESISTOR >		325	8-848-567-11	DRUM ASSY DOU-03A	
R711	1-249-428-11	CARBON 8.2K 5% 1/4W		F901	△ 1-532-744-11	FUSE, GLASS TUBE (2.5A) (US, Canadian)	
R712	1-249-434-11	CARBON 27K 5% 1/4W		F901	△ 1-532-286-00	FUSE, TIME-LAG (T2.5A) (AEP, G)	
		< SWITCH >		FL701	1-519-672-11	INDICATOR TUBE, FLUORESCENT	
S701	1-571-520-11	SWITCH, SLIDE (TIMER)		M901	A-2003-448-A	MOTOR ASSY (CASSETTE COMPARTMENT)	
S703	1-570-974-11	SWITCH, SLIDE (REC MODE)		M902	8-835-361-01	MOTOR, DC U-17B (CAPSTAN)	
*****				M903	X-3363-109-1	MOTOR ASSY (CAM)	
	* 1-639-305-11	TOP END SENSOR BOARD *****		M905	X-3363-110-1	MOTOR ASSY (REEL)	
	* 3-368-456-01	HOLDER (END SENSOR LIGHT)		PM902	1-454-536-11	SOLENOID, PLUNGER (BT CONTROL)	
	* 3-368-457-01	HOLDER (END SENSOR) (RECEIVE) < DIODE >		PM903	1-454-535-11	SOLENOID, PLUNGER (BRAKE)	
D01	8-719-951-03	DIODE GL-453 < PHOTO INTERRUPTER >		S901	△ 1-554-920-21	SWITCH, PUSH (AC POWER) (1 KEY) (POWER)	
PH03	8-729-907-25	TRANSISTOR PT4850F		T901	△ 1-450-556-11	TRANSFORMER, POWER (US, Canadian)	
PH04	8-729-907-25	TRANSISTOR PT4850F		T901	△ 1-450-557-11	TRANSFORMER, POWER (AEP, G)	
*****				*****			
				ACCESSORIES & PACKING MATERIALS *****			
				1-465-972-11 REMOTE COMMANDER (RM-D670A)			
				1-559-533-11 CORD, CONNECTION			
				3-754-303-11 MANUAL, INSTRUCTION (AEP, Canadian) (English, French, Spanish, Portuguese)			
				3-754-303-21 MANUAL, INSTRUCTION (US) (English)			
				3-754-303-41 MANUAL, INSTRUCTION (AEP) (German, Dutch, Swedish, Italian)			
				3-754-303-51 MANUAL, INSTRUCTION (G) (German)			
				* 4-931-451-01 CUSHION			
				* 3-373-774-01 INDIVIDUAL CARTON			
				* 3-703-044-26 LABEL, CAUTION (US, Canadian)			
				3-703-450-01 INSTRUCTION (US)			

The components identified by mark △ or dotted line with mark △ are critical for safety. Replace only with part number specified.

Les composants identifiés par une marque △ sont critiques pour la sécurité. Ne les remplacer que par une pièce portant le numéro spécifié.

When indicating parts by reference number, please include the board name.

<u>Ref. No.</u>	<u>Part No.</u>	<u>Description</u>	<u>Remarks</u>
-----------------	-----------------	--------------------	----------------

HARDWARE LIST

#1	7-682-548-09	SCREW +BVTT 3X8 (S)	
#2	7-685-647-79	SCREW, TAPPING	
#3	7-685-646-79	SCREW +BVTP 3X8 TYPE2 N-S	
#5	7-682-547-04	SCREW +BVTT 3X6 (S)	
#6	7-682-560-04	SCREW +BVTT 4X6 (S)	
#7	7-621-772-10	SCREW +B 2X4	
#8	7-621-772-00	SCREW +B 2X3	
#9	7-682-545-09	SCREW +B 3X4	
#10	7-621-255-45	SCREW +P 2X6	
#11	7-621-775-08	SCREW +B 2.6X3	
#12	7-621-773-86	SCREW +B 2.6X4	
#13	7-682-147-15	SCREW, TR	
#20	7-621-255-20	SCREW +BVTT 2X4 (S)	
#21	7-627-854-07	PRECISION SCREW +P 2X2.5 TYPE3	
#22	7-627-556-17	SCREW, PRECISION +P 2.6X3 TYPE1	
#23	7-627-852-27	+P 1.7X3	
#24	7-621-255-15	SCREW +P 2X3	
#25	7-627-552-27	SCREW, PRECISION +P 1.7X2	
#26	7-627-552-47	SCREW, PRECISION +P 1.7X4	
#27	7-621-772-08	SCREW +B 2X3	
#28	7-621-772-18	SCREW +B 2X4	
#29	7-685-133-19	SCREW +BTP 2.6X6 TYPE2 N-S	
#30	7-685-534-19	SCREW +BTP 2.6X8 TYPE2 N-S	

When indicating parts by reference number, please include the board name.

DTC-670

SONY SERVICE MANUAL

US Model
Canadian Model
AEP Model







SUPPLEMENT-1

File this supplement with the service manual.

1. Service Manual Correction
2. FWD torque adjustment procedure change
3. Circuit design and board change (MAIN board)
4. Addition part

1. Service Manual Correction

 : Corrected portion

Page	Incorrect	Correct
12	FWD Torque Check Check Procedure: 3. Confirm that the FWD torque value (take-up side rewinding torque) is between 10 – 20 g·cm (0.14 – 0.28 oz·inch).	FWD Torque Check Check Procedure: 3. Confirm that the FWD torque value (take-up side rewinding torque) is between 10 – <u>16</u> g·cm (0.14 – <u>0.22</u> oz·inch).  
12	FWD Back Tension Check and Adjustment Check procedure: 3. Confirm that the back tension (supply side) is between 5 – 6 g·cm (0.07 – 0.09 oz·inch). If this is not satisfied, adjust back tension by rotating the FWD back tension adjustment screw equipped on the side surface of the mechanical deck. After completion of adjusting, be sure to apply screw lock.	FWD Back Tension <u>Adjustment</u> <u>Adjustment procedure:</u> 3. <u>Turn the FWD back tension adjustment screw locked on the mechanical deck side so that the minimum value of FWD back tension torque (supply side) is between 4 – 5 g·cm (0.06 – 0.07 oz·inch).</u> <u>Also, make sure that the maximum reading does not exceed 8 g·cm (does not exceed 0.11 oz·inch).</u> After completion of adjusting, be sure to apply screw lock.    

2. FWD torque adjustment procedure change

	Serial Number
US model	800, 201 and later
Canadian model	A700, 001 and later
AEP model	505, 401 and later
Germany model	4, 520, 301 and later

- Sets with the serial numbers shown above have a new variable resistor (RV301) on the main board which serves for FWD torque adjustment. The adjustment for these sets should therefore be carried out as described below.

FWD Torque Adjustment:

Adjustment procedure:

1. Put the set into the test mode (main · servo) and load the FWD torque meter TW-7131 (8-909-708-71)
2. Put the set into the PLAY (▶) mode.
3. Adjust RV301 so that the minimum value of FWD take up torque (take-up side rewinding torque) is between 10 – 11 g·cm (0.14 – 0.15 oz·inch).
Also, make sure that the maximum reading does not exceed 16 g·cm (does not exceed 0.22 oz·inch).
4. Confirm that the value indicated by the torque meter is maintained for one full cycle.

Adjustment point:

– Main board – (Component side)

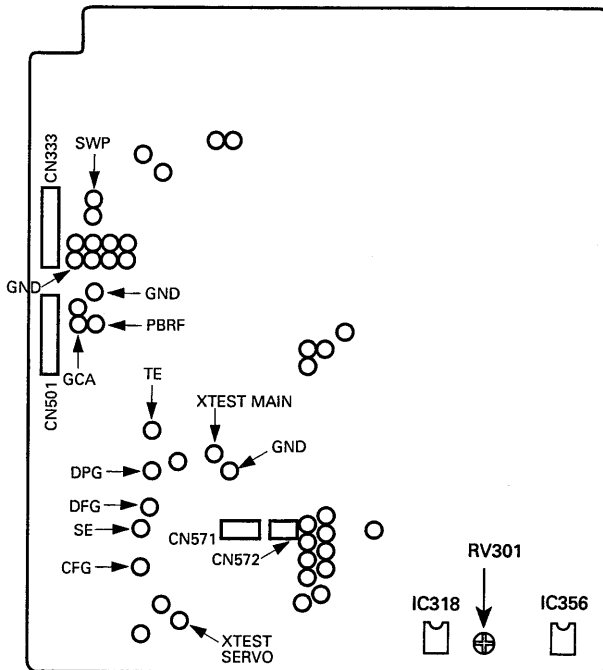

3. Circuit design and board change (MAIN board)

Printed Wiring Board

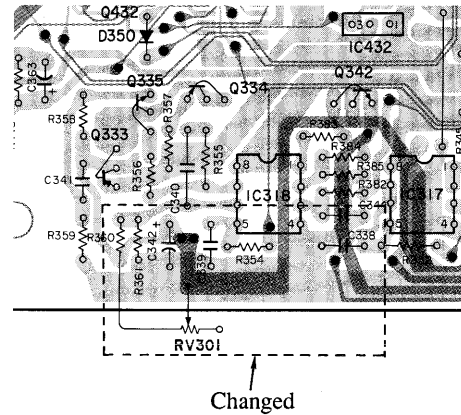

Schematic Diagram

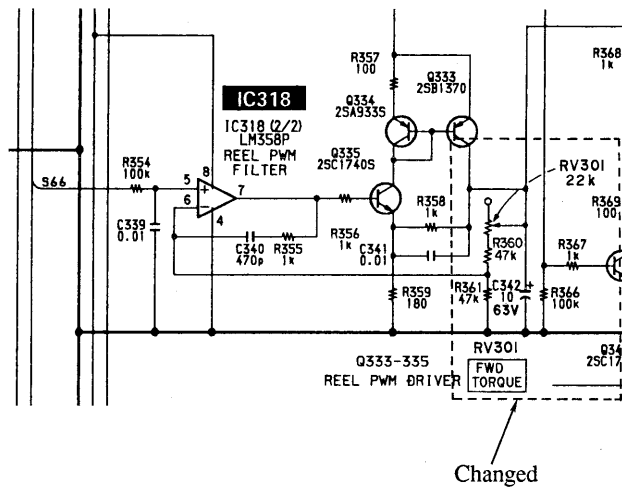

4. Additional part

Ref. No.	Part No.	Description	Remarks
		<VARIABLE RESISTOR>	
RV301	1-226-773-11	RES, ADJ, METAL 22K (FWD TORQUE)	

DTC-670

SONY SERVICE MANUAL

US Model
Canadian Model
AEP Model

CORRECTION-1

Correct your service manual as shown below.

☛ : indicates corrected portion.

