

DTC-57ES/750

SERVICE MANUAL

Free service manuals

Gratis schema's

Digitized by

www.freesevicemanuals.info



Photo : DTC-57ES

US Model
 Canadian Model
 AEP Model
 E Model
 DTC-57ES
 US Model
 Canadian Model
 UK Model
 DTC-750

SPECIFICATIONS

Tape	Digital audio tape
Recording head	Rotary head
Recording time	Standard: 120 minutes Long-play mode: 240 minutes (with DT-120)
Tape speed	Standard: 8.15 mm/s, Long play mode: 4.075 mm/s
Drum rotation	Standard: 2,000 rpm, Long-play mode: 1,000 rpm
Error correction	Double Read Solomon code

Tape

Track pitch	13.6 μ m (20.4 μ m)
Sampling frequency	48 kHz, 44.1 kHz, 32 kHz
Modulation system	8-10 Modulation
Transfer rate	2.46 Mbit/sec.
Number of channel	2 channels, stereo
D/A conversion (Quantization)	Standard: 16-bit linear Long-play mode: 12-bit non-linear
Frequency response	Standard: 2-22,000 Hz (\pm 0.5 dB) Long-play mode: 2-14,500 Hz (\pm 0.5 dB)

		DTC-57ES (AEP, E model), DTC-750	DTC-57ES (US, Canadian model)
Signal to noise ratio	SP	more than 92dB	more than 93dB
	LP		more than 92dB
Dynamic range	SP	more than 92dB	more than 93dB
	LP		more than 92dB
Total harmonic distortion (1kHz)	SP	less than 0.0045%	less than 0.004%
	LP	less than 0.08%	less than 0.08%

*SP : Standard

LP : Long-play mode

Model Name Using Similar Mechanism	NEW
Tape Transport Mechanism Type	DATM-100

Wow and flutter Below measurable limit (\pm 0.001% W. PEAK)

Input

	Jack type	Impedance	Rated input level
LINE IN	phono jack	47 kohms	-4 dBs
DIGITAL IN	phono jack	75 ohms	0.5 Vp-p, 20%
DIGITAL IN	optical jack	—	—

Output

	Jack type	Impedance	Rated output	Load impedance
LINE OUT	phono jack	470 ohms	-4 dBs	More than 10 kohms
PHONES	stereo phone jack	220 ohms	0.6 mW	32 ohms
DIGITAL OUT (DTC-57ES)	phono jack	75 ohms	0.5 Vp-p \pm 20%	—

DIGITAL OUT (optical jack): wavelength 660 nm

- continued on next page -

DIGITAL AUDIO TAPE DECK

SONY®



MICROFILM

General

Power requirements 120V AC, 60Hz (US, Canadian models)
240V AC, 50Hz (UK model)
220-230V AC, 50/60Hz (AEP model)
110-120, 220-240V AC adjustable,
50/60Hz (E model)

Power consumption 32 W

**Dimensions (w/h/d)
& Weight**

DTC-57ES:
Approx. 470x125x350mm
(18 5/8x5x13 7/8 inches)
Approx. 8kg (17 lb 10oz)
DTC-750:
Approx. 430x125x350mm
(17x5x13 7/8 inches)
Approx. 7.2kg (15 lb 14oz)

Remote commander (supplied)

Remote control system Infrared control
Power requirements 3V DC, with two size AA (R6)
batteries

Dimensions Approx. 63 x 19 x 175 mm
(w/h/d)
(2 1/2 x 3/4 x 7 inches)

Weight Approx. 130 g (4 oz) incl.
batteries.

Supplied accessories

Sony batteries SUM-3(NS) (2)
Audio connecting cords (2 phono plugs - 2 phono plugs,
stereo for line inputs and outputs) (2)
Screws (4) (DTC-57ES only)

Design and specifications subject to change without notice.

SAFETY-RELATED COMPONENT WARNING!!

COMPONENTS IDENTIFIED BY MARK Δ OR DOTTED LINE WITH MARK Δ ON THE SCHEMATIC DIAGRAMS AND IN THE PARTS LIST ARE CRITICAL TO SAFE OPERATION. REPLACE THESE COMPONENTS WITH SONY PARTS WHOSE PART NUMBERS APPEAR AS SHOWN IN THIS MANUAL OR IN SUPPLEMENTS PUBLISHED BY SONY.

ATTENTION AU COMPOSANT AYANT RAPPORT À LA SÉCURITÉ!

LES COMPOSANTS IDENTIFIÉS PAR UNE MARQUE Δ SUR LES DIAGRAMMES SCHÉMATIQUES ET LA LISTE DES PIÈCES SONT CRITIQUES POUR LA SÉCURITÉ DE FONCTIONNEMENT. NE REMPLACER SES COMPOSANTS QUE PAR DES PIÈCES SONY DONT LES NUMÉROS SONT DONNÉS DANS CE MANUEL OU DANS LES SUPPLÉMENTS PUBLIÉS PAR SONY.

TABLE OF CONTENTS

<u>Section</u>	<u>Title</u>	<u>Page</u>
1. GENERAL		
	Features	4
	Location and Function of Controls	5
	Connections	8
	Block Diagram	8
	Clock Setting	9
2. DISASSEMBLY		10
3. ADJUSTMENTS		13
3-1.	Electrical Adjustments	15
3-2.	Checks for Date Function	17
4. DIAGRAMS		
4-1.	Circuit Boards Location	18
4-2.	Block Diagram	19
4-3.	Waveforms	23
4-4.	Semiconductor Lead Layouts	25
4-5.	Printed Wiring Boards - Power supply / Display / MD section -	28
4-6.	Schematic Diagram - Power supply / Display / MD section -	31
4-7.	Printed Wiring Boards - Main section -	36
4-8.	Schematic Diagram - Main section -	39
4-9.	IC Block Diagrams	43
4-10.	Pin Functions	47
5. EXPLODED VIEWS		
5-1.	Cabinet Section	57
5-2.	Front Panel Section	58
5-3.	Chassis Section	59
5-4.	Mechanism Section 1	60
5-5.	Mechanism Section 2	61
5-6.	Mechanism Section 3	62
5-7.	Mechanism Section 4	63
6. ELECTRICAL PARTS LIST		64

PRECAUTIONS FOR INSPECTIONS AND REPAIR WITH POWER OFF

Before beginning repair work after turning OFF the main switch, be sure to first remove CN932 (EH8P) of the power board. When assembling the equipment, be sure to plug this connector last.

This is because, even with the main switch turned OFF, electric charges still remain in the smoothing capacitor in the power board. Therefore, if another flexible board is inserted or removed, a terminal of the power supply may short an adjacent terminal while destroying the device.

MODEL IDENTIFICATION

- SPECIFICATION LABEL -

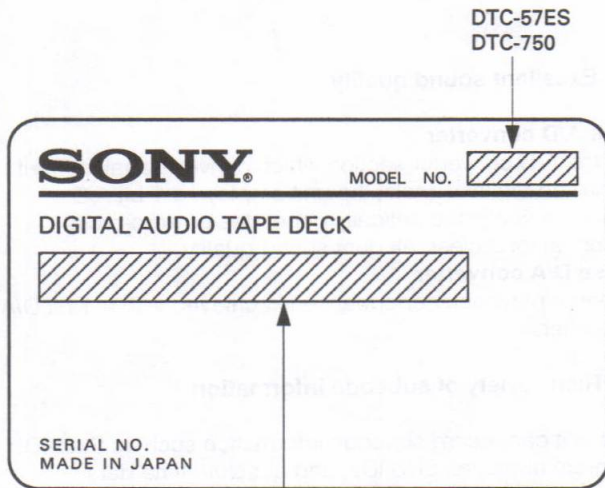

US, Canadian model : AC 120V 60Hz 32W
 AEP model : AC 220-230V~ 50/60Hz 32W
 UK model : AC 240V 50Hz 32W
 E model : AC 110-120, 220-240V~
 adjustable, 50/60Hz 32W

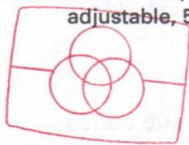

Free service manuals
 Gratis schema's
 Digitized by

www.freesevicemanuals.info

SAFETY CHECK-OUT

After correcting the original service problem, perform the following safety check before releasing the set to the customer: Check the antenna terminals, metal trim, "metallized" knobs, screws, and all other exposed metal parts for AC leakage. Check leakage as described below.

LEAKAGE TEST

The AC leakage from any exposed metal part to earth ground and from all exposed metal parts to any exposed metal part having a return to chassis, must not exceed 0.5mA (500 microamperes). Leakage current can be measured by any one of three methods.

1. A commercial leakage tester, such as the Simpson 229 or RCA WT-540A. Follow the manufacturers' instructions to use these instruments.
2. A battery-operated AC milliammeter. The Data Precision 245 digital multimeter is suitable for this job.

CAUTION
 Danger of explosion if battery is incorrectly replaced. Replace only with the same or equivalent type recommended by the equipment manufacturer. Discard used batteries according to manufacturer's instructions.

ADVERSEL !
 Lithiumbatteri – Eksplosionsfare ved fejlagtig håndtering. Udskiftning må kun ske med batteri af samme fabrikat og type. Lever det brugte batteri tilbage til leverandren.

ADVARSEL
 Lithiumbatteri – Eksplosjonsfare. Ved utskifting benyttes kun batteri som anbefalt av apparatfabrikanten. Brukt batteri returneres apparatleverandren.

VARNING
 Explosionsfara ved felaktigt batteribyte. Använd samma batterityp eller en ekvivalent typ som rekommenderas av apparattillverkaren. Kassera använt batteri enligt fabrikantens instruktion.

VAROITUS
 Paristo voi räjähtää, jos se on virheellisesti asennettu. Vaihda paristo ainoastaan laitevalmistajan suosittelemaan tyyppiin. Hävitä käytetty paristo valmistajan ohjeiden mukaisesti.

3. Measuring the voltage drop across a resistor by means of a VOM or battery-operated AC voltmeter. The "limit" indication is 0.75V, so analog meters must have an accurate low-voltage scale. The Simpson 250 and Sanwa SH-63Trd are examples of a passive VOM that is suitable. Nearly all battery operated digital multimeters that have a 2V AC range are suitable. (See Fig.A)

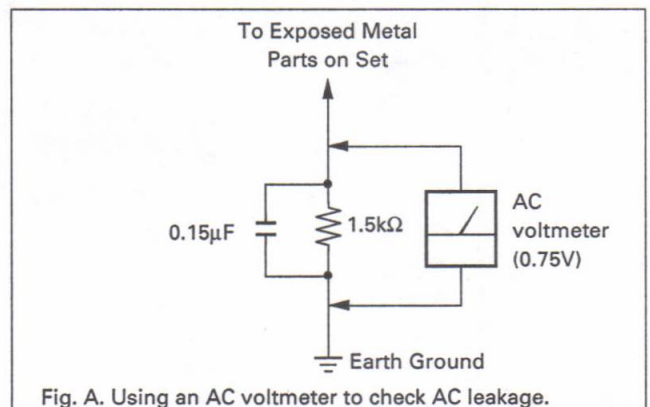

Fig. A. Using an AC voltmeter to check AC leakage.

SECTION 1**GENERAL**

This section is extracted from instruction manual.

Features**Serial copy management system**

This unit utilizes the serial copy management system that permits digital-to-digital recording for one generation. You can record CD sound or other digital formats through a digital-to-digital connection. (See page 42.)

Date Function automatically memories the recording date and time

The year, month, day, day of the week, hour, minute and second are automatically memorized in the subcode area during recording, so that during playback you can display this data to check when the tape was recorded. This function is especially convenient when recording live performances, etc.

Three sampling frequencies

Recording/playback can be done with three sampling frequencies (48 kHz, 44.1 kHz and 32 kHz).

48 kHz: For analog and digital input signals in a standard mode.

44.1 kHz: For compact disc and pre-recorded DAT tape.

32 kHz: For analog input signals in a long-play mode.

Long play mode

This unit can operate in a long-play mode. Analog input signals can be recorded or playback for up to four consecutive hours when the DT-120 DAT cassette tape is used. The sampling frequency will be 32 kHz in the long-play mode.

Visible cassette loading

You can view the tape operation through the lid of the cassette compartment. Due to a revolutionary new transport mechanism, cassette loading time has been significantly reduced.

Excellent sound quality**1-bit A/D converter**

For the A/D converter section which converts analog input signals to digital signals, the unit employs a 1-bit A/D converter which theoretically generates no zero-cross distortion for a clear, elegant sound quality.

Pulse D/A converter

Superior playback performance is achieved with a 1-bit D/A converter.

Rich variety of subcode information

This unit can record subcode information such as Start IDs, program numbers, Skip IDs, and absolute time data, enabling you to quickly locate tunes and display the playback time in the same manner as when playing compact discs.

Digital fade-in/fade-out

Professional sounding fade-in/fade-out of either digital or analog signals can be accomplished by use of the FADER button.

Post edit recording of sub codes

You can record or rewrite the following sub codes after the audio signal recording has been completed.

Start ID: Signifies the beginning of a selection.

Program number: Gives a number to the selection.

Skip ID: Signifies the beginning of a portion to be skipped.

End ID: Signifies the end position of recording/playback.

Since sub codes are written on the tape separately from audio signals, the audio signals are not affected.

Location and Function of Controls

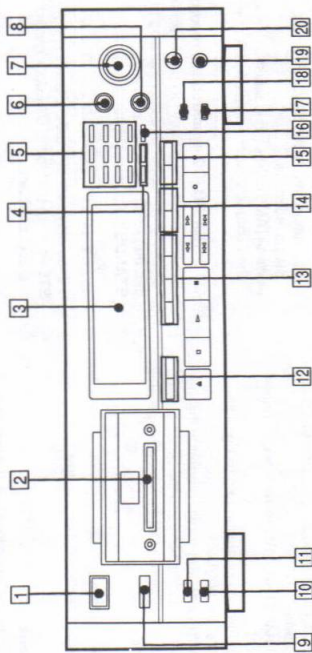

Front Panel/Remote Commander

- 1 POWER switch**
Turns the power on and off.
- 2 Cassette compartment**
Insert a cassette with the window side up and the safety tab facing you.
- 3 Display window**
- 4 DATE buttons**
RECORDED: Press to display the recording day of the tape being played.
PRESENT: Press to display the current time. Each time the RECORDED or PRESENT button is pressed, day, month and year display, the day of the week display or hour, minute and second display is switched sequentially.
- 5 Music select buttons**
Numeric buttons (0-9): Designate the desired program number to be played back before starting playback. Designate the desired number in the record-pause mode, the program number is written consecutively from the designated number.
CLEAR: Use to cancel the program number which has been mistakenly entered.
MUSIC SCAN: Use this feature to listen to the beginning of each selection successively.
- 6 INPUT selector**
Set according to the signal to be recorded.
ANALOG: For recording from the equipment connected to the LINE IN jacks.
OPTICAL: For recording from the equipment connected to the DIGITAL IN (OPTICAL) jack.
COAXIAL: For recording from the equipment connected to the DIGITAL IN (COAXIAL) jack.
- 7 REC LEVEL (recording level) control**
Adjust the recording level for the analog input signals. When recording digital signals, it is not necessary to adjust the recording level.
- 8 BALANCE control**
Adjust the recording balance for the analog input signals. When recording digital signals, it is not necessary to adjust the recording balance.
- 9 Remote sensor**
Receives the signal from the Remote Commander.
- 10 REC MODE selector**
Normally set to the STANDARD position. When this selector is set to the LONG position, you can record analog input signals or digital signals with 32 kHz in the long-play mode.
- 11 TIMER switch**
Normally set to the OFF position. When recording or playing back at the desired time using a commercially available audio timer, set to the REC position or the PLAY position respectively.

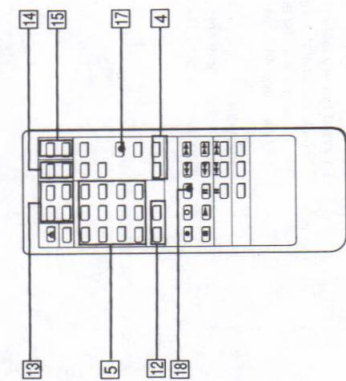

- 12 COUNTER buttons**
MODE: Selects the counter display in the display window among the linear counter (tape running time), absolute time, elapsed time of the selection, and total remaining time of tape. Each time you press the button, the display changes sequentially.
RESET: Resets the linear counter to "0M 00S".
- 13 START ID buttons**
AUTO: Press to turn on and off the AUTO indicator. When the AUTO indicator is lit, the start ID will automatically be written during recording. When the AUTO indicator is not lit, press the START ID WRITE button at the point where you want to write a start ID.
WRITE: Press to write the start ID at the desired point during recording or playback.
ERASE: Press to erase a start ID. When a start ID and a program number are written on the tape, both codes are simultaneously erased by pressing this button.
RENUMBER: Press to renumber all programs on the tape. When only the start IDs are written, pressing this button will insert the proper program numbers beginning with "1". The tape will rewind and start from the beginning to accomplish this function.
- 14 SKIP ID buttons**
WRITE: Press at the beginning of the portion you may wish to skip later. A skip ID will be written from the point where you pressed this button.
ERASE: Press to erase the nearest skip ID which is before the current position.
- 15 END ID buttons**
WRITE: Press to write the ID signifying the end of playback or recording.
ERASE: Press to erase the end ID.
- 16 CLOCK SET button**
Press to adjust the time of the clock built in this unit. In this mode, the MUSIC SCAN button and the 0 button function as the + and - buttons respectively.
- 17 MARGIN RESET button**
Press to reset the margin of peak level.
- 18 FADER button**
Press to fade in or fade out during recording or playback.
- 19 Headphones jack**
Insert the headphones plug to this jack.
- 20 PHONE LEVEL control**
The PHONE LEVEL control adjusts the headphones volume level.

Free service manuals
Gratis schema's
Digitized by
www.freecservice manuals.info

Remote Commander Operation

Each button on the remote commander functions in the same way as those having the same name on the front panel. However, the following operations cannot be performed using the remote commander. Use the front panel controls instead.

- Tuning the power on and off
- Selecting digital(optical/coaxial)/analog input source
- Setting the clock
- Adjusting the recording level and balance
- Adjusting the headphones level
- Setting the timer recording/playback
- Selecting the record mode (standard or long)

The following operations can be performed only with the remote commander.

- Activating CD synchronized recording using a Sony CD player and controlling the CD player
- Locating the desired selection on the Compact Disc or setting the CD player in the pause mode (possible only when a Sony CD player is used.)
- Repeat play
- Skip play
- RMS* play
- *RMS: Random Music Sensor

Installing Batteries

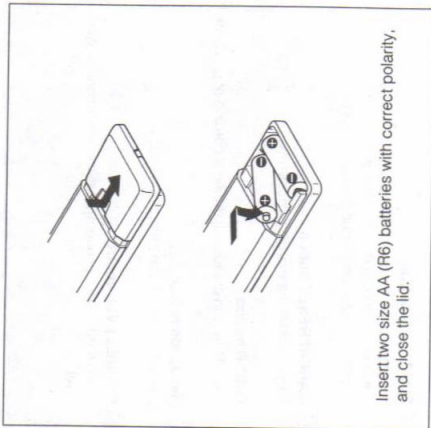

Insert two size AA (R6) batteries with correct polarity, and close the lid.

Notes on remote control

- Do not expose the remote sensor on the deck to strong light such as direct sunlight, lighting apparatus, etc.
- Do not place any obstructions between the Remote Commander and the remote sensor, or else operations will not be performed correctly.
- The controllable range is limited. Point the Remote Commander directly at the remote sensor on the deck.
- When remote control operation distance becomes shorter, the batteries are weak. Replace both batteries with new ones.

To avoid battery leakage

When the commander will not be used for a long period of time, remove the batteries to avoid damage caused by battery leakage and corrosion.

Battery life

About half a year of normal operation can be expected when using the Sony SUM-3 (NS) batteries.

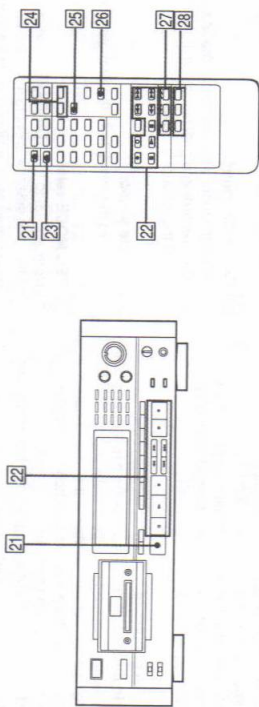

Front Panel/Remote Commander

21 OPEN/CLOSE button

Press to open or close the cassette compartment.

22 Tape operating buttons

- (stop): Press to stop recording or playback.
- ▶ (play): Press to play back the tape.
- REC (recording): Press to enter the record-pause mode. After pressing this button, press the II or ▶ button.
- II PAUSE (pause): Press to stop for a moment during recording or playback. To restart recording or playback, press this button again or press the ▶ button.
- If the unit is left in the pause mode for about 10 minutes, it will automatically be released and the deck will enter the stop mode. To restart recording or playback from the stop mode, press the ●REC or ▶ button respectively.
- MUTE (record muting): Inserts a sound-muted portion (space).
- ◀◀ (AMS): Press to locate the beginning of the selection during the playback.
- ▶▶ (rewind/review, fast-forward/cue): In the stop mode, press to rewind/fast-forward the tape. During playback, press to rewind or fast-forward the tape while listening to the sound.

23 DISPLAY MODE button

Changes the display mode. (Refer to page 10.)

24 RMS play buttons

ENTER: To program the selections in a desired order, press this button after pressing the numeric buttons.
CHECK: Press to check the programmed contents.

25 REPEAT 1/ALL button

Press to play a desired portion repeatedly. Each time you press the button, the indicator changes as follows:
REPEAT 1 → REPEAT ALL → off

26 SKIP PLAY button

Press to activate the skip ID code function. The portion of the tape previously marked will be skipped.

27 CD operation buttons

- Operative only for the Sony CD player equipped with a Remote Commander.
- II (pause): Press this button twice to start playback. Press this button once in the playback mode, the deck enters the pause mode.
- ◀◀▶▶ (AMS): Press to locate the desired selection on the Compact Disc during playback or in the stop mode.

28 CD SYNCHRO (CD synchronized recording) buttons

(The playback of the Sony CD player equipped with a Remote Commander and the recording of the DAT deck can be performed simultaneously.)
STANDBY: Press to set the unit in the record-standby mode.
START: Press to start recording of the DAT deck and then playback of the CD player.
STOP: Press to stop the DAT deck recording and the CD player playback.

Display Window

To turn off the display window
When the power is turned on, the display window also is turned on. During recording or playback, all display or some parts of the display can be turned off as follows:
When operating with the front panel controls
While pressing the COUNTER MODE button, press the 0 button.

When operating with the remote commander
Each time you press the above buttons, the indicators change as follows:

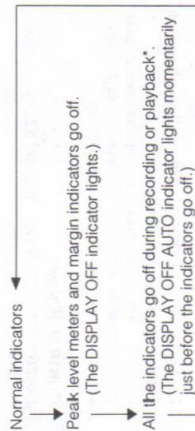

Normal indicators
Peak level meters and margin indicators go off. (The DISPLAY OFF indicator lights.)
All the indicators go off during recording or playback* (The DISPLAY OFF AUTO indicator lights momentarily just before the indicators go off.)

To change the brightness of the display window
While pressing the COUNTER MODE or DISPLAY MODE button except during recording or playback, the DISPLAY OFF AUTO indicator lights. In this case, all the indicators go off immediately after recording or playback starts.

1 LONG PLAY mode indicator
Lights when recording or playback is being performed in the long play mode.

2 TOC (Table Of Contents) indicator
When a pre-recorded DAT cassette is played back, this indicator will light.

3 DATE indicator
Lights when pressing the RECORDED button to display the recording day of the tape being played. Flashes when pressing the PRESENT button to display the current time.

4 REMAINING (remaining time):
Shows the remaining time of the tape.
PGM TIME (program time):
Lights when the counter shows the elapsed time of the current selection.
ABS TIME (absolute time) indicator:
Lights when the counter shows the elapsed time from the beginning of the tape.

5 Time indicator
Indicates the tape running time, absolute time, elapsed time of the current selection, remaining time or recording day. Each time the COUNTER MODE button is pressed, the display is changed.

6 Fade in/out indicator
FADE IN: Flashes when recording or playback fades in.
FADE OUT: Flashes when recording or playback fades out.

7 AM/PM indicators
Show AM or PM of the time.

8 INPUT selector indicators
The OPTICAL or COAXIAL indicator lights according to the position of the INPUT selector. No indicator lights when the INPUT selector is set to the ANALOG position.

9 SAMPLING FREQ. (Sampling frequency) indicator
48 KHz: For recording/playback of analog input signals (standard mode)
44.1 KHz: For recording/playback of CD or a pre-recorded DAT cassette
32 KHz: For recording/playback of analog input signals (long-play mode)

10 REPEAT indicators
REPEAT 1: Lights when a desired selection is played back repeatedly.
REPEAT ALL: Lights when all the selections are played back repeatedly.

11 AMS (Automatic Music Sensor)/RMS (Random Music Sensor) indicators
Show the number of selections to be skipped ahead or behind in the AMS operation. When designating a selection directly by the numeric button and the right arrow button, the display shows the program number of the target selection while the selection is being searched for. When programming the desired selections in the RMS operation (page 38), the display shows the program number of the selection to be programmed.

12 DISPLAY OFF/AUTO indicators
The DISPLAY OFF indicator lights when peak level meters and margin indicators are turned off. The DISPLAY OFF AUTO indicator lights momentarily before all the indicators are turned off.

13 SKIP PLAY indicator
When this indicator is lit during playback, the portion marked by the skip ID is skipped and playback continues from the next start ID.

14 MUSIC SCAN indicator
Lights after pressing the MUSIC SCAN button to listen to the beginning of each selection successively.

15 CAUTION indicator
Lights when moisture condensation occurs. If this happens, the deck stops functioning automatically. (See page 4.)

16 START ID mode indicators
AUTO: Lights when the AUTO button is pressed to write the start ID automatically.
RENUMBER: Lights when the RENUMBER button is pressed to renumber the program numbers.
WRITE: Lights when writing the start ID manually.
AUTO RENUMBER: Lights when renumbering program numbers automatically.

SHIFT RENUMBER: Lights when shifting the start ID and program number position.

17 SKIP ID mode indicator
WRITE: Lights when writing the skip ID.
ERASE: Lights when erasing the skip ID.

18 END ID mode indicator
WRITE: Lights when writing the end ID.
ERASE: Lights when erasing the end ID.

19 START ID indicator
Flashes when writing (for 9 or 18 seconds) or erasing a start ID code, and lights when the start ID is detected during playback.

20 SKIP ID indicator
Lights when writing (for 1 or 2 seconds) or erasing a skip ID code or when the skip ID is detected during playback.

21 MARGIN indicator
Shows how much margin there is between the peak level of input audio signal and 0 dB.

22 REHEARSAL indicator
Lights while the rehearsal function is activated (page 28).

23 COPY PROHIBIT indicator
Lights when recording the digital signal with the copy prohibit code. In this case, record with the LINE IN jacks.

24 STEP/PGM NO. indicator
Shows the program number of the selection being played. When programming the desired selection in the RMS operation (page 36), the display shows the step number of the programmed selection.

25 Frequencies map
When pressing the 4 button while keeping the COUNTER MODE button pressed, bars indicating the sampling frequencies with which the tape was recorded appear on the peak level meters.

26 Peak level meters
Indicate the level of the audio signal being recorded during recording, and the peak values of the audio signal recorded on the tape during playback.

27 Tape operation indicators
[REC]: Lights during recording or in the record-pause mode.
▶ Lights during recording or playback. It also lights in the record-pause mode or in the play-pause mode.
■: Lights in the record-pause mode or in the play-pause mode.

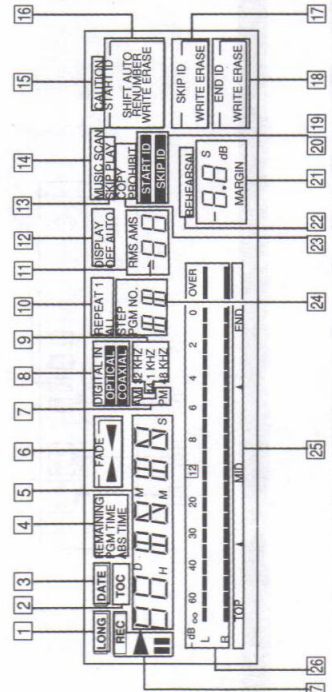

Block Diagram

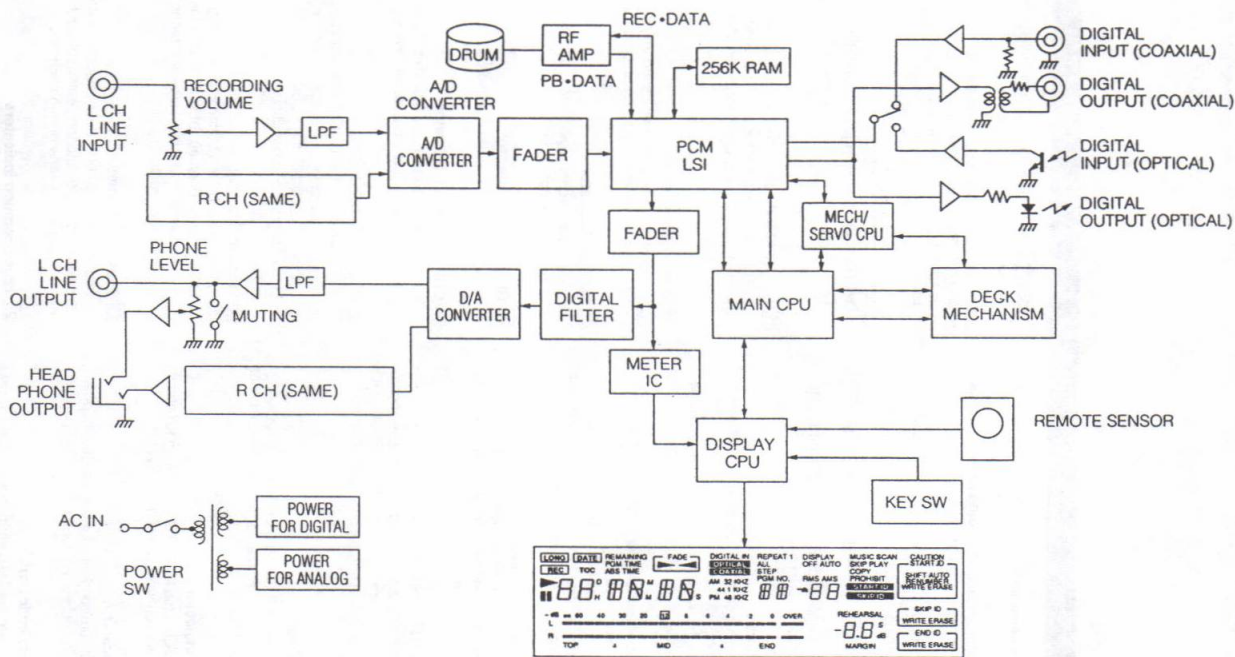

Connections

Rear Panel Jacks

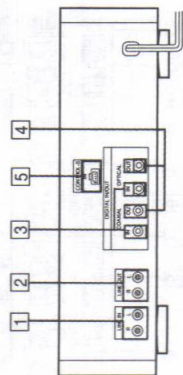

1 LINE IN (line input) jacks (phono jack)

Connect to the recording outputs of an amplifier. Signals supplied by the amplifier can be recorded using the sampling frequency of 48 kHz in the standard play mode or 32 kHz in the long play mode.

2 LINE OUT (line output) jacks (phono jack)

Connect to the DAT or tape inputs of an amplifier. The playback signal of this deck will be output.

3 COAXIAL/OPTICAL DIGITAL IN (digital input) jacks (coaxial phono jack/optical jack)

Connect to the digital outputs of an amplifier having a built-in D/A converter or other digital source, such as a CD player for digital-to-digital recording.

4 COAXIAL/OPTICAL DIGITAL OUT (digital output) jack (coaxial phono jack/optical jack)

Connect to the digital inputs of an amplifier having a built-in D/A converter or another DAT deck, for playback of a DAT cassette or digital-to-digital recording.

5 CONTROL-S IN jack

Connect to the CONTROL-S output of a Sony amplifier or receiver for remote control.

Notes on connection

- Use the connecting cords specified in the illustrations.
- Turn off the power for all equipments before making connections.
- Be sure to insert the plugs firmly into the jacks. Loose connections may cause hum and noise. When unplugging, grasp the plug and not the cord.

Notes on the optical cable

- Do not bend the cord. When the cord is not used, curl it with a diameter of more than 15 cm (5 7/8 inches).
- Do not use it under high temperatures.
- When the optical cable is not connected, cover the OPTICAL IN/OUT jacks with the supplied caps.

Note on sound signals

When connecting an optical cable to the DIGITAL IN/DIGITAL OUT jacks, sound signals (L/R) are transmitted together through the cable.

Note on the CONTROL-S IN jack

To remotely control this unit through a receiver or amplifier, connect the input of this unit to the CONTROL-S output of a Sony receiver or amplifier, with a CONTROL-S cable. When this connection is used, only remote control commands sent through the receiver or amplifier will be executed. The remote sensor of this unit will not function.

Clock Setting

This unit employs a built-in clock to keep track of the current date and time. Once you set the date and time, this information will be recorded on the tape along with the audio signal during recording. This function is very convenient because it allows you to check when the tape was recorded when playing the tape later.

Setting the date and time

Example: Setting the clock to 10:30:00 AM, July 4, 1991 (Thursday)

Setting the day

- 1 Display the date.**
- 2 Set the year.**
- 3 Set the month.**
- 4 Set the day.**
- 5 Complete the setting procedure.**

Setting the day of the week

- 1 Display the day of the week.**
- 2 Set the day of the week.**
- 3 Complete the setting procedure.**

Setting the time

- 1 Display the time.**
- 2 Set the hour.**
- 3 Set the minutes.**
- 4 Set the seconds to 0.**
- 5 Start the clock simultaneously with the signal from a timecast (telephone, etc.).**

To confirm the date or time

Press the PRESENT button to display the date, the day of the week or time. When pressing the PRESENT button once, the date is displayed, when pressing twice, the day of the week is displayed and when pressing three times, the time is displayed. To return to the original counter display, press the COUNTER button.

Time display

AEP, UK, E models :
The time is displayed in 24-hour format.

US, Canadian models :

The time is displayed in 12-hour format.
Midnight and noon are displayed as follows:
Midnight: 12:00 AM
Noon: 12:00 PM

Built-in clock

This unit's built-in clock operates using a quartz oscillator, and time variations caused by changes in temperature, etc., may accumulate. For precise recording of hour, minute, and second data by the built-in date function, it is recommended that you set the clock once a week.

Precautions when setting the clock

- Set the clock while the tape is stopped.
- Although this unit's clock automatically adjusts for leap years and long and short months, do not enter a date which does not exist.

The day of the week is displayed as follows.

Sunday	SU
Monday	MO
Tuesday	TU
Wednesday	WE
Thursday	TH
Friday	FR
Saturday	SA

Note

This unit uses a back-up battery to keep the clock running when the power is turned off. The life of the battery under normal use is approximately five years. When the battery starts to run down, the clock will stop operating normally. When this occurs, have the battery replaced at your dealer or nearest Sony Service Center (a battery replacement fee is required).

SECTION 2

DISASSEMBLY

- Remove the following devices shown by ❶, etc. In the order of the numbers.

[CASE]

Unscrew the four case attachment screws and remove the case.

[CASSETTE WINDOW]

- Press the OPEN/CLOSE switch to effect LOADING OUT STATE (if power is not supplied) rotate the pulley in the left side of the Mechanism Deck counterclockwise.)
- Remove the cassette by lifting the window up.

MECHANISM SECTION

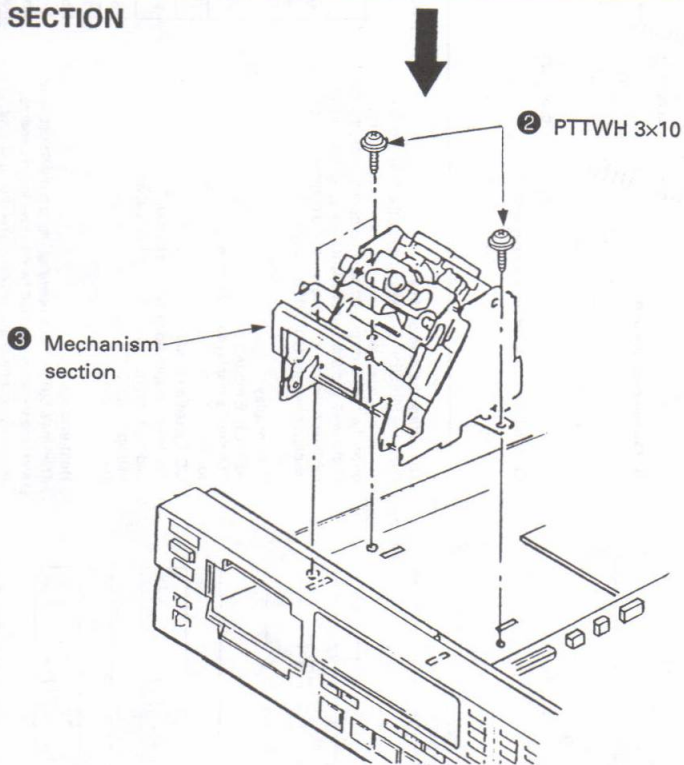

HOLDER

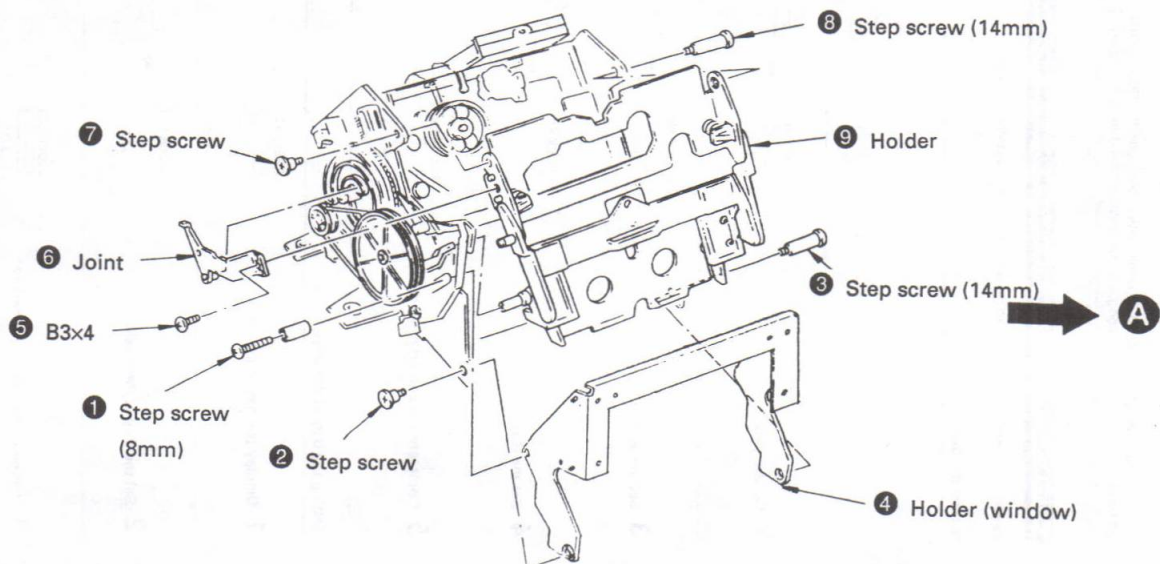

CASSETTE COMPARTMENT MOTOR (M901), PULLEY, GEAR (CAM) AND SLIDER

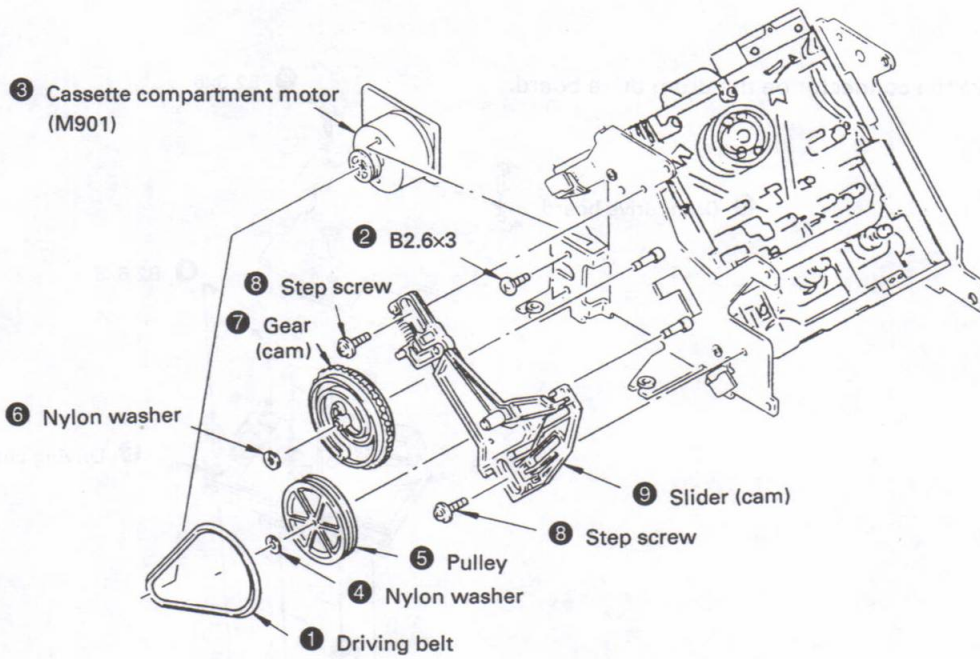

A



DRUM

- 1 Remove the drum lead wires on rear side of the drum from the connector.

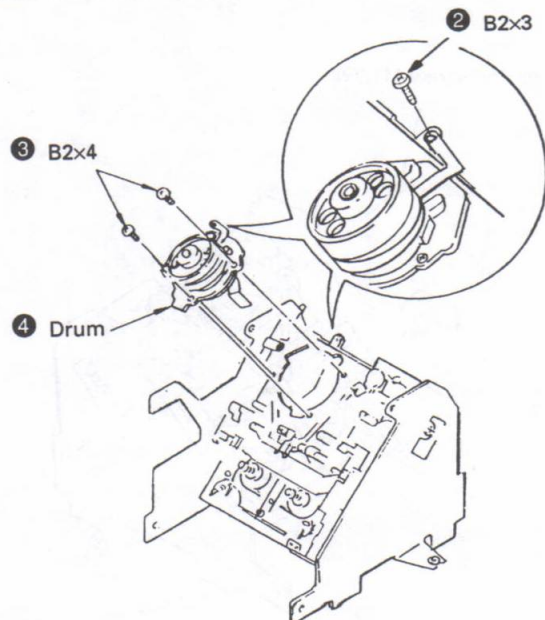

DRUM DRIVE BOARD, DRIVING CHASSIS

1 Remove the connector on the drum drive board.

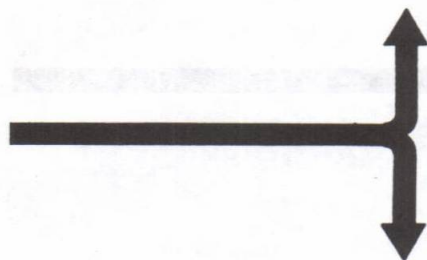
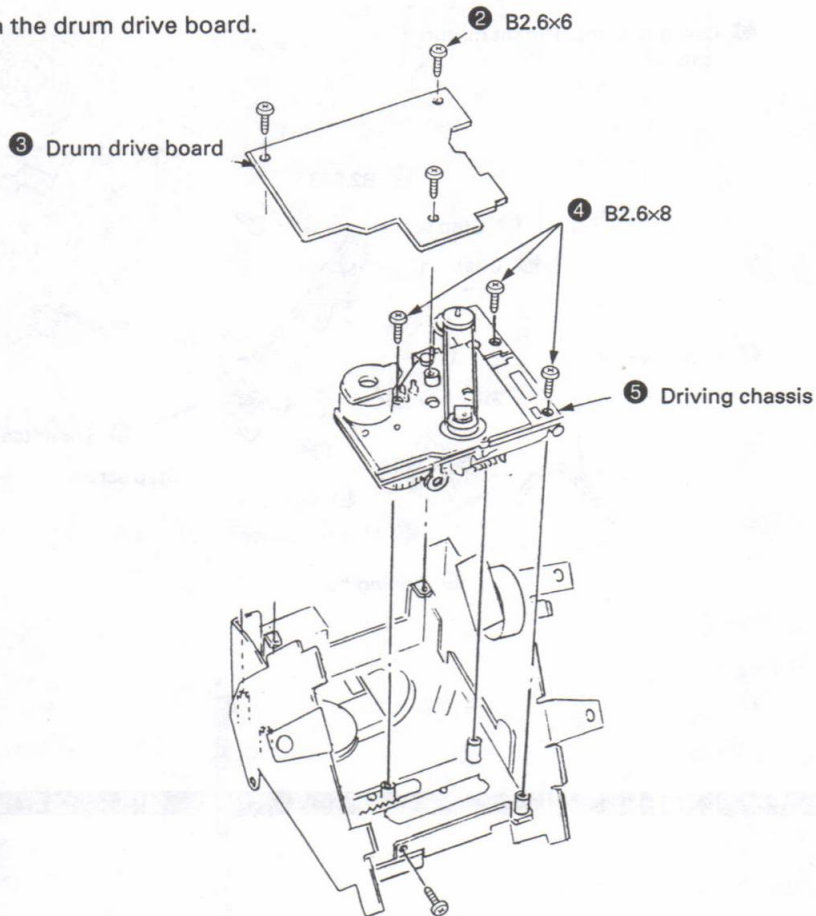

CAPSTAN MOTOR (M902)

1 Precision screw M1.7x4

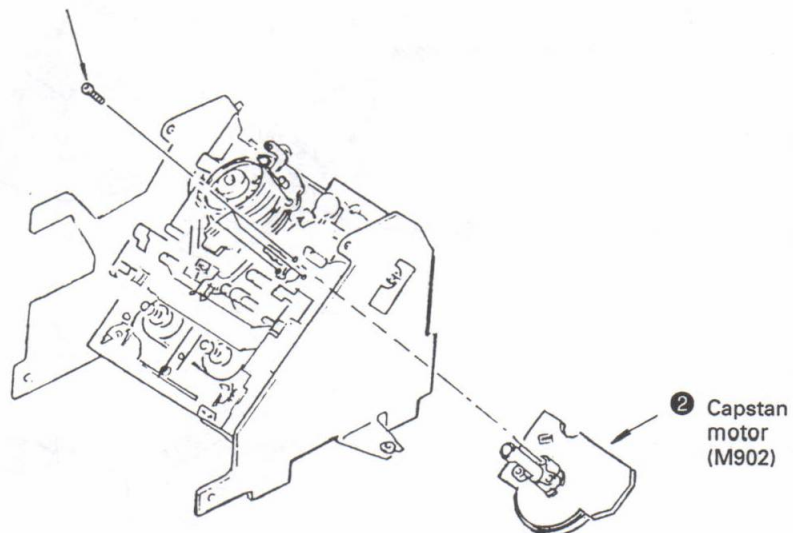

SECTION 3

ADJUSTMENTS

Notes When Making Adjustments

- Adjustments should be performed in the order listed.
- Use the following test tapes :

TY-7111 (8-909-812-00)	Level
TY-7252 (8-909-822-00)	Tracking
TY-7551 (8-909-814-00)	Functions
TY-30B (8-892-358-00)	Blank

Use the following torque meter:

TW-7131 (8-909-708-71) FWD

- Switches and controls should be set as follows unless otherwise specified.

TIMER switch	:	OFF
REC MODE switch	:	LONG
INPUT switch	:	COAXIAL
REC LEVEL control	:	Min.
PHONES LEVEL control	:	Min.

- Creating an end sensor cassette

- Press the tape slider lock and move the slider in the direction indicated by the arrow.

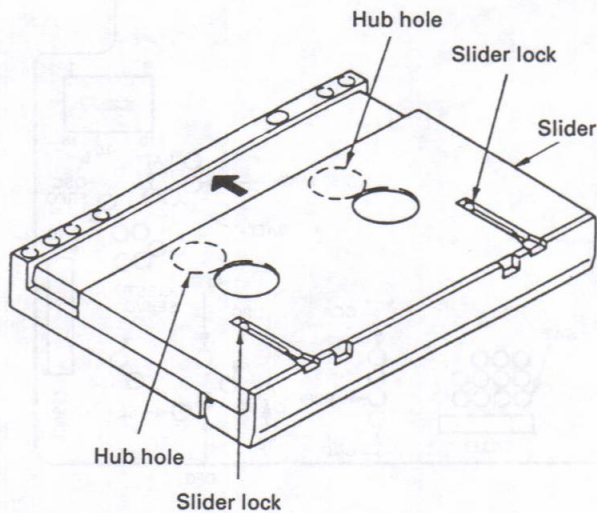

- Open the lid and cut the tape.

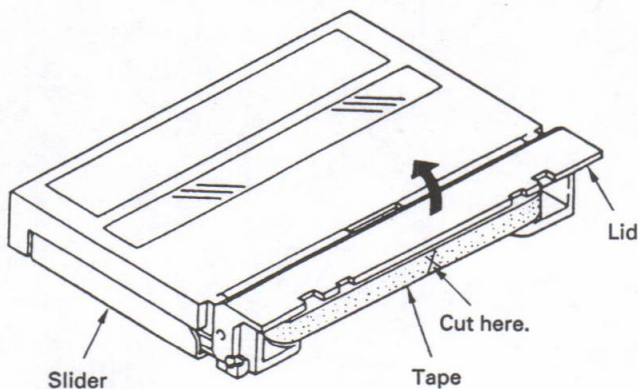

- Turn the hubs until the tape is completely inside the cassette (both T and S sides).
The end sensor cassette for end sensor adjustment is now ready for use.

- Be careful not to move RV1 and RV2 on the RF AMP board in the mechanism assembly.

- To adjust the tape path and guides, remove the holder assembly as shown in the diagram and use the DAT holder jig (J-8000-002-A). This will make it easier to perform adjustments.

- First turning the pulley counterclockwise to put it in loading out status will make removal and reattachment of the holder assembly easier.
- To perform adjustments, turn the pulley clockwise to put it in loading in status, load the cassette tape and set the IN switch to the ON position.

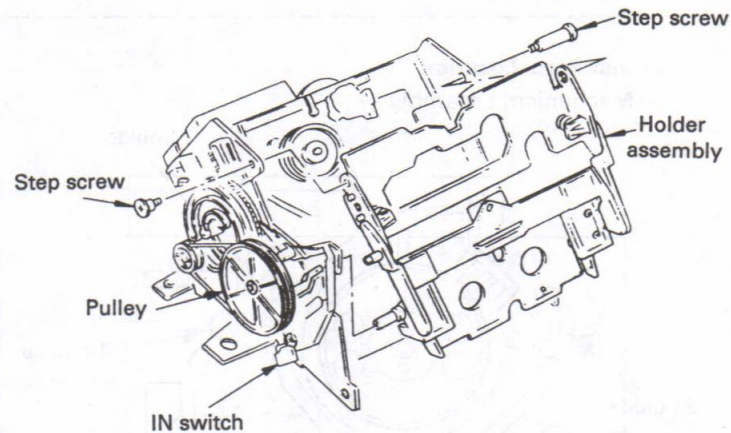

- Test mode

The test mode is effected by shorting TP (XTEST MAIN, XTEST SERVO and XTEST DISP) on the main board and the operation switch board and GND.

- Test mode (main)

Turn OFF the main switch, connect XTEST MAIN on the main board to GND and perform the following adjustments.

- Tape path adjustment
- DPG adjustment
- ATF pilot (GCA) checking

- Test mode (servo)

Turn OFF the main switch, connect XTEST SERVO on the main board to GND and perform the following adjustments.

- End sensor checking
- FWD torque checking
- FWD back tension checking

- Test mode (display)

You can check the following FL display tube and the panel switch by turning OFF the main switch, disconnecting CN932 on the power board, removing flexible board CN752 on the operation switch board, connecting XTEST DISP to GND, connecting CN932 again and then turning ON the main switch.

Each grid of the FL display tube sequentially lights up while all tubes being lighted up finally.



Level meters go out one after one.



Press any of the remote controller for DAT in this state. Thus, all level meters go out. (It may sometimes occur that one or two meters remain lighting up according to switch setting at that time.)



Everytime a switch on the panel is pressed, display tubes light up sequentially one after one. With all keys once pressed, all level meters go out.

- To reset the test mode, disconnect the wire shorting XTEST and GND. After completion of adjusting, be sure to reset the test mode.

8. Check the following items for correct tape speed, after completion of adjusting.

- (1) Set the REC MODE switch to STANDARD and check for normal recording and playback. (× 1)
- (2) Set the REC MODE switch to LONG and check for normal recording and playback. (× 0.5)
- (3) With QUE (▶ + ▶▶) or REVIEW (▶ + ◀◀), check that qurrr, qurrr sound is heard. (× 3, × 8)
- (4) Check that correct time is displayed after FF (▶▶▶) or REV (◀◀◀). (× 16)
- (5) Check that SEARCH (▶▶▶, ◀◀◀) is normal.

Adjust Parts Location

— Mechanism assembly —

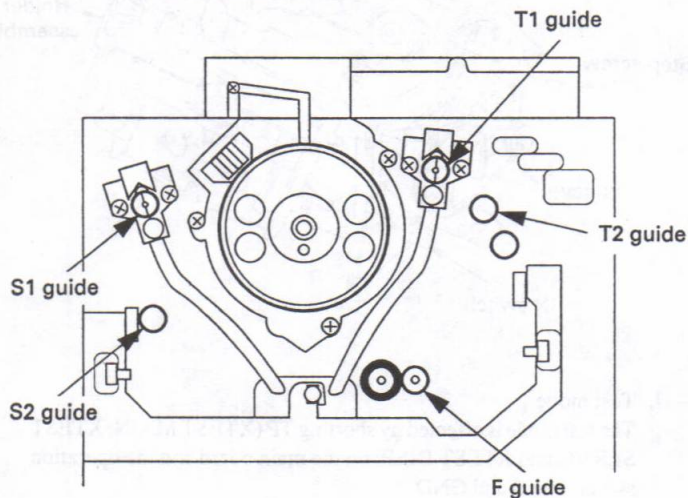

— Main board —

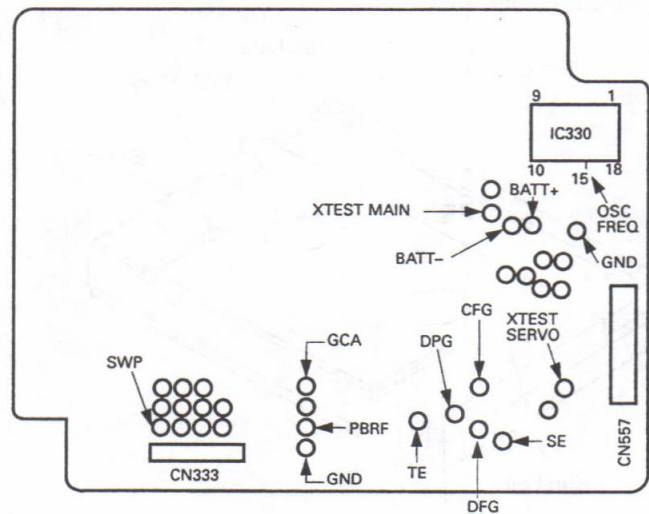

— Display board —

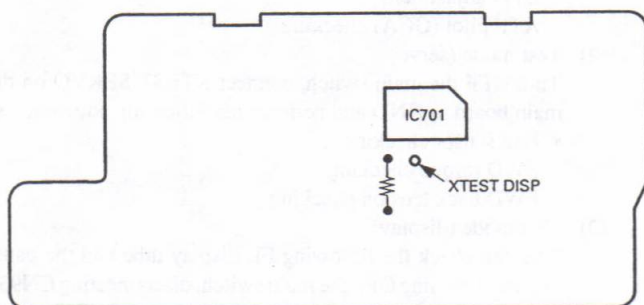

SECTION 4
DIAGRAMS

4-1. CIRCUIT BOARDS LOCATION

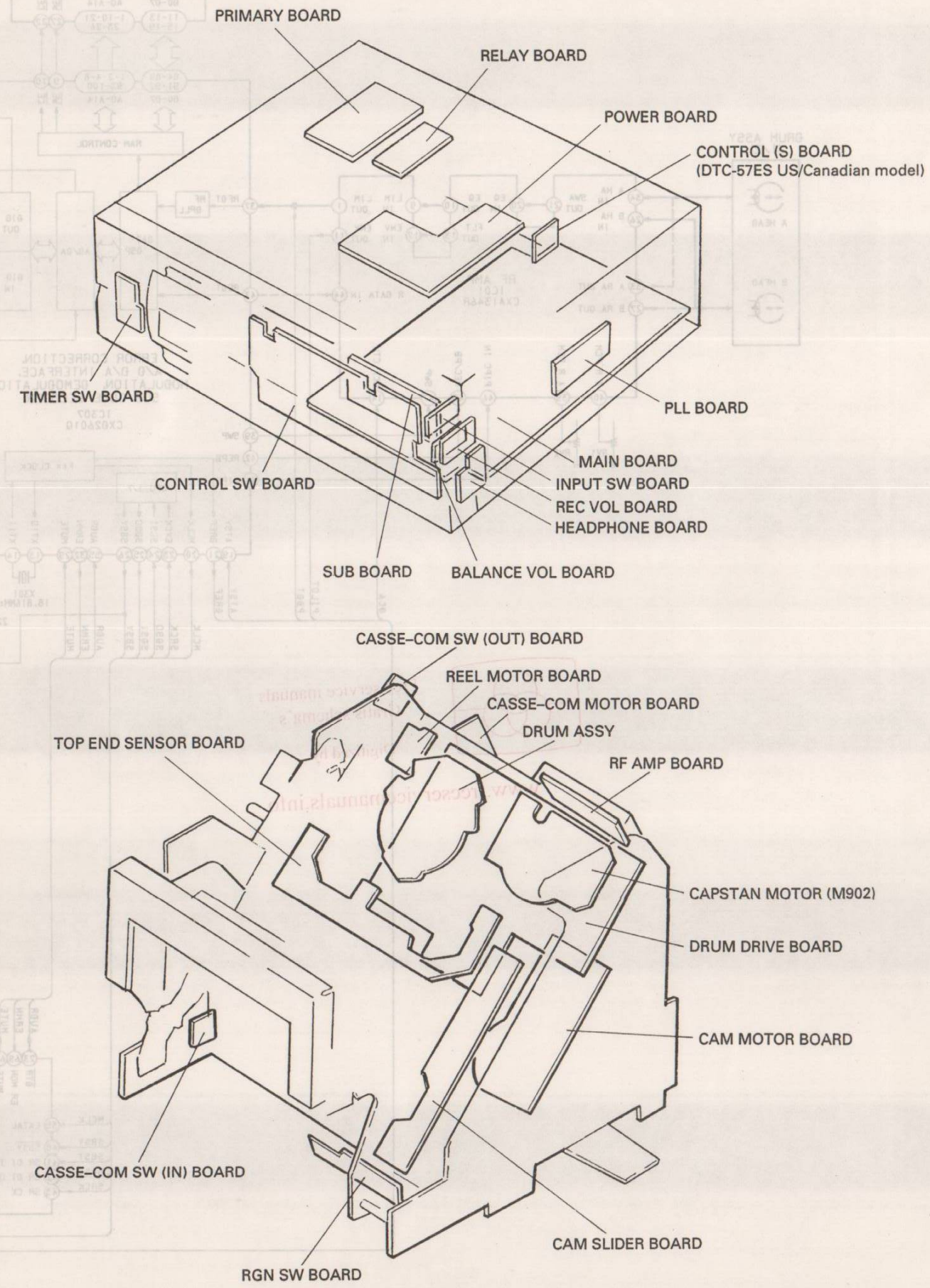

3-1. ELECTRICAL ADJUSTMENTS

End Sensor Adjustment

Perform the following adjustment when the holder has been removed or part of the mechanism deck section replaced.

Adjustment Procedure:

1. Connect an oscilloscope to the test land SE (in the S side) and TE (in the T side) of the main board.
2. Actuate the test mode (servo), mount an end sensor cassette and effect the STOP (■) mode.
3. Check that p-p values of waveform of the oscilloscope satisfy the following.

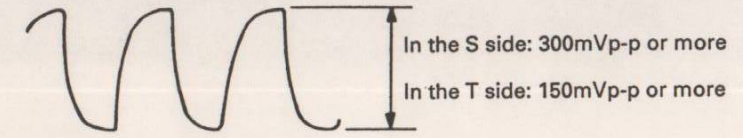

FWD Torque Adjustment

Adjustment Procedure:

1. Put the set into the test mode and load the FWD torque meter TW-7131 (8-909-708-71).
2. Put the set into the PLAY (▶) mode.
3. Confirm that the FWD torque value (take-up side rewinding torque) is between 10 - 20 g-cm (0.14 - 0.28 oz-inch).
4. Confirm that the value indicated by the torque meter is maintained for one full cycle.

Adjustment Point: main board

FWD Back Tension Check

Check procedure:

1. Put the set into the test mode and load the FWD torque meter TW-7131 (8-909-708-71)
2. Put the set into the PLAY (▶) mode.
3. Confirm that the back tension (supply side) is between 5 - 6 g-cm (0.07 - 0.09 oz-inch).
If this is not satisfied, adjust back tension by rotating the FWD back tension adjustment screw equipped on the side surface of the mechanical deck. After completion of adjusting, be sure to apply screw lock.
4. Confirm that value indicated by the torque meter is maintained for one full cycle.

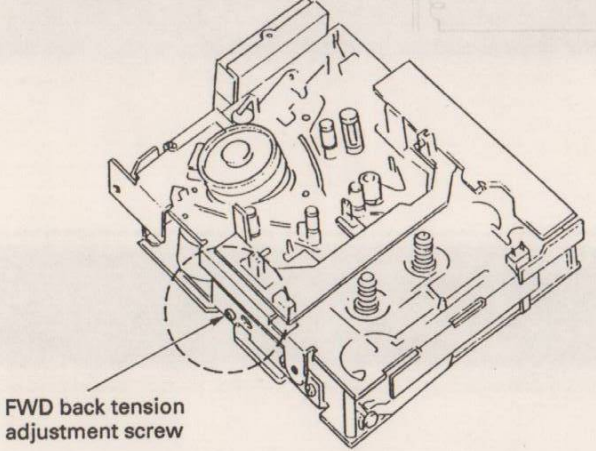

To tighten (clockwise) — back tension becomes larger.
To loosen (counterclockwise) — back tension becomes smaller.

Tape Path Fine Adjustments (x 1.5 FWD Mode)

Perform the following adjustment when the drum has been replaced.

Adjustment Procedure :

1. Connect an oscilloscope CH-1 to TP (PBRF) and CH-2 to TP (SWP) on the main board.
 2. Put the set into the test mode and load test tape TY-7252 (8-909-822-00).
 3. Press the AMS (▶▶) key. Each part of switches on Test Mode.
-
4. With the REC MODE switch set to STANDARD (ATF: OFF) and the TIMER REC switch set to PLAY or REC (OFFSET: + or -), fine adjust the S1 and T1 guides so that the oscilloscope RF signal waveform remains the same when high-low is repeated.

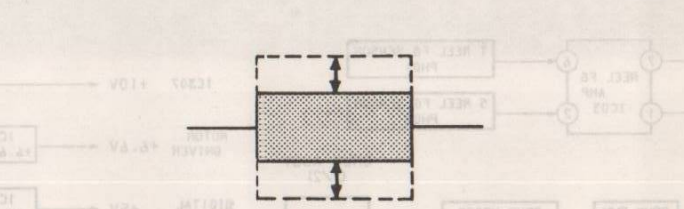

* Finish the adjustment by screwing in.

5. Check the RF signal waveform with the REC MODE switch set to LONG (ATF: ON) and the TIMER REC switch set to PLAY or REC (OFFSET: + or -).

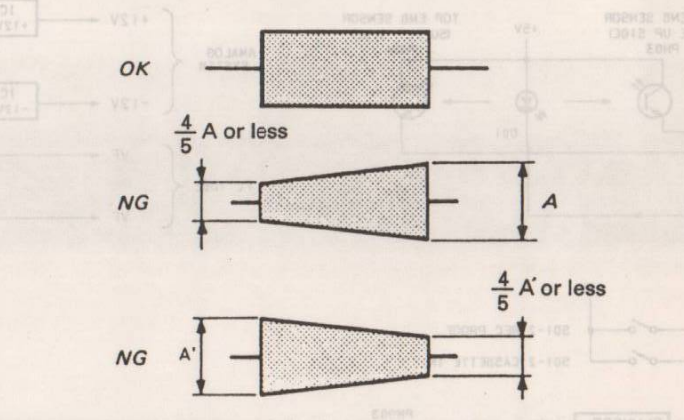

6. Check the RF signal waveform with the REC MODE switch set to LONG (ATF: ON) and the TIMER REC switch set to PLAY or REC (OFFSET: 0).
 - (1) Confirm that the RF signal waveform peak value (B) is 60 mV or more.

- (2) Confirm that the undershoot level of the RF signal waveform's flat portion is within 10%.

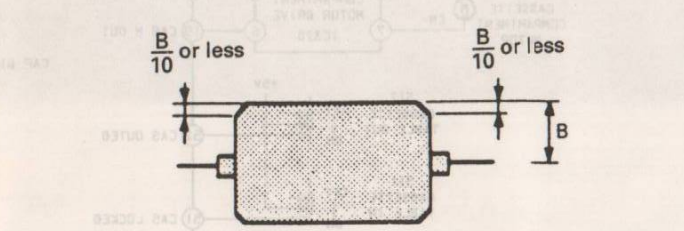

7. When the measured values are not within the above tolerances, repeat items 3 - 6 above.

Adjustment Point: mechanism assembly

DPG Adjustment

Perform the following adjustment without fail when the drum has been replaced.

Adjustment Procedure:

1. Connect oscilloscope CH-1 to TP (PBRF) and CH-2 to TP (SWP) on the main board. (Use CH-2 as the trigger. When the CH-2 signal is inverted, the trailing edge can be used for synchronization.)
2. Put the set into the test mode and load test tape TY-7252 (8-909-822-00).
3. Set the REC MODE switch to LONG (ATF: ON) and the TIMER REC switch to OFF (OFFSET: 0).
4. Press the AMS (▶▶) key.
5. Press the ◀◀ and ▶▶ keys as appropriate so that the gap between the oscilloscope SWP and RF signals becomes 650 ± 15 μsec. (Hold the ◀◀ and ▶▶ keys down for more than 1 second to perform rough adjustment. Hold them down for approximately 0.2 seconds for fine adjustment.)

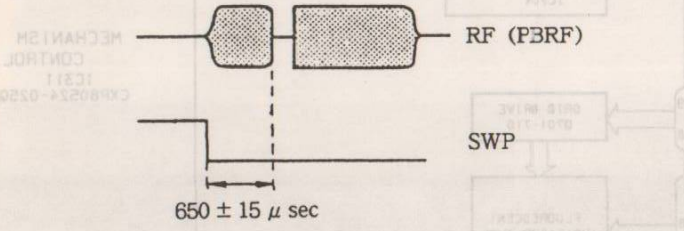

ATF Pilot (GCA) Adjustment

Perform this adjustment after cleaning the heads with a cleaning cassette.

Adjustment Procedure:

1. Connect oscilloscope CH-1 to TP (GCA: Gain Control Amp.) and CH-2 to TP (SWP) on the main board. (When the CH-2 signal is inverted, the trailing edge can be used for synchronization.)
2. Put the set into the test mode and load test tape TY-7111 (8-909-812-00).

3. Actuate the PLAY (▶) mode and check that the GCA waveform on the oscilloscope is as follows.

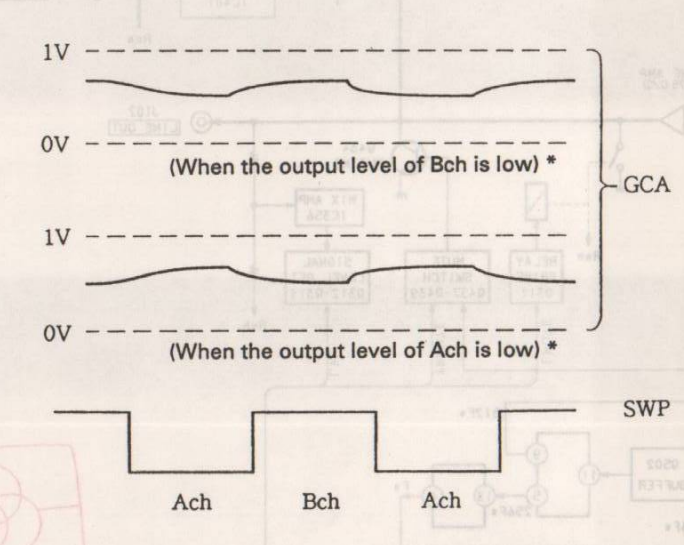

* Slightly changes depending on the state of the head. NG if the GCA waveform is 1V or more or equal to the GND level.

3-2. CHECKS FOR DATE FUNCTION

Clock IC Back-up Check

When there is the short-circuit position on the pattern around the lithium battery (BAT301) or the clock IC (IC330) or disconnecting CN398 on removing the front panel assembly the clock is reset. (In spite of pressing PRESET button, the data indication becomes " _ _ Y _ _ M _ _ D _ _ H _ _ M _ _ S _ _ ") At this time, check the back-up function by the procedures given below.

- (1) Connect DC voltmeter to TP (BATT+) and TP (BATT-) on the main board.
- (2) When the power is off, the voltage value of the item (1) should be less than +30 mV. (When the voltage value becomes +30 mV or more, Check around IC330 or replace IC330.)
- (3) When the power is on, the voltage value of the item (1) should be less than 0 mV (- (minus) indication). (When the voltage value becomes + (plus) indication, Check around IC321 or replace IC321.)
- (4) When the above voltage values are normal, set the preset date and time (year, month, day, day of the week, hour, minute, second) according to the instruction manual.
- (5) After setting the time on the item (4), turn power off and turn power on several seconds later, and check the clock works normally.

Back-up Battery Replacement

The life of the back-up battery under normal use (normal temperature, normal humidity) is approximately ten years or more. (On the instruction manual, described "approximately five years".) Be careful about the following points on the battery replacement.

- Repair the cause of the battery wastage by performing mentioned above "Clock IC Back-up Check".
- The open-circuit voltage of the replaced battery is 3.0 V or more as the new one, and when it is 2.0 V or less, it is completely consumed, replace it with new one.
- After the battery replacement, perform "Clock IC Back-up Check" again and set the time.

Clock Frequency Adjustment

Adjustment Procedure:

1. Connect a frequency counter to pin ⑮ of IC330 and GND on the main board.
2. Turn power on and confirm that the reading on the frequency counter is 2048.00 ± 0.02 Hz. (in normal temperature)
3. Perform "Clock IC Back-up Check" described above.

* Time setting procedure described on page 9.

4-3. WAVEFORMS

1 FL701 ①-⑩pin 36Vp-p, 1ms

2 IC701 ②-⑩pin 38Vp-p, 0.5μs

3 IC701 ①-⑩pin 36Vp-p, 2μs

4 IC701 ④-⑦pin 5.2Vp-p, 10ms

5 IC702 ③pin 5.2Vp-p, 5μs

6 IC702 ②pin 6.4Vp-p, 1μs

7 IC702 ①pin 5Vp-p, 0.5μs

8 IC306 ⑩pin 5Vp-p, 0.5μs

9 IC306 ⑤pin 6Vp-p, 0.1μs

10 IC306 ⑤pin 5Vp-p, 5μs

11 IC306 ⑤pin 5Vp-p, 5μs

12 IC306 ①, ⑩pin 5Vp-p, 1μs

13 IC307 ⑩pin 4.2Vp-p, 18MHz

14 IC307 ⑩pin 3Vp-p, 18MHz

15 IC307 ⑩pin 5.2Vp-p, 5ms

16 IC307 ⑩pin 5Vp-p, 10ms

17 IC307 ⑩pin 100mVp-p, 2ms

18 IC306 ⑩pin 5Vp-p, 0.2μs

19 IC307 ⑩pin 4Vp-p, 0.5μs

20 IC307 ⑩pin 6Vp-p, 1μs

21 IC307 ⑩pin 6Vp-p, 0.5μs

22 IC307 ⑩pin 6Vp-p, 0.5μs

23 IC307 ⑩pin 3.6Vp-p, 49MHz

24 IC307 ⑩pin 1Vp-p, 49MHz

25 IC307 ⑩, ⑫pin 5Vp-p, 5μs

26 IC307 ⑦pin 6Vp-p, 0.1μs

27 IC307 ⑩pin 5Vp-p, 1μs

28 IC307 ⑩pin 5Vp-p, 5μs

29 IC307 ⑩pin 5Vp-p, 2μs

30 IC312 ⑩pin 3.8Vp-p, 0.5μs

31 IC312 ⑩, ⑪, ⑫pin 5Vp-p, 10ms

32 IC312 ⑩pin 5Vp-p, 10ms

33 IC359 ⑩pin 5Vp-p, 0.5μs

34 IC359 ⑩pin 6Vp-p, 0.1μs

35 IC359 ⑩pin 5.6Vp-p, 0.5μs

36 IC362 ⑤, ⑩pin 5Vp-p, 0.5μs

37 IC362 ⑦pin 5Vp-p, 0.5μs

38 IC362 ⑩pin 6.4Vp-p, 0.1μs

39 IC362 ⑩pin 7Vp-p, 0.5μs

40 IC362 ⑩, ⑪, ⑫, ⑬pin 6Vp-p, 0.1μs

41 IC362 ⑩, ⑪, ⑫, ⑬pin 6Vp-p, 0.1μs

42 X304 ⑩pin 1Vp-p, 32.768kHz

43 IC330 ⑩pin 16Vp-p

44 IC311 ⑩pin 4.5Vp-p, 0.5μs

45 IC311 ⑩pin 5Vp-p, 2ms

46 IC311 ⑩pin 5Vp-p, 2ms

47 IC311 ⑩pin 5Vp-p, 10ms

48 IC311 ⑩pin 5Vp-p, 10ms

49 IC311 ⑩pin 3.5Vp-p, 10μs

50 IC311 ⑩pin 100mVp-p, 10μs

51 IC311 ⑩pin 5Vp-p, 10μs

52 IC311 ⑩, ⑫pin 5Vp-p, 10μs

53 IC311 ⑩pin 15mVp-p, 10μs

4-4. SEMICONDUCTOR LEAD LAYOUTS

CX5339-KP CXD2561M

CX20115A

CXK1011P LF412CN M5238P NE5532P RC4558P RC4560DD μPC358C

CXA1364R

CXD1136Q

CXD2560M

CXD2601AQ

CXK58257M-12L

CXP5058H-657Q CXP80524-040Q CXP80524-025Q

M5F7805L M5F7805L-720 M5F7808L M5F7812L TA7805S μPC2406HF

DTA114ES DTC114ES

2SA1585S-OR 2SC4115S-OR 2SC2785-HFE

2SA933S-OR 2SC3623A-K 2SD1387

2SB1370-EF

2SB734-34

2SB798-DL

2SC1623

M5F7912L TA7905S

M54641L

PST529C PST529E

RP5C62

TC5081AP

LM358M-FL63

MC74AC74N MC14011BCP SN74HCU04AN SN74HC10ANS SN74HC393AN SN74HC74ANS SN74LS624N TC74HC132AP

MSM6338RS SN74HC153ANS

2SD2012

2SK241GR

HZS24-3L HZS6A1L 1SS168 1SS202-1 11EQS04 11ES2

KV1320

RBA-406B

1SS106 30D2-FC

25

26

27

28

29

30

31

32

33

34

35

36

37

38

39

40

41

42

43

44

45

46

47

48

49

50

51

52

53

54

55

56

57

58

59

60

61

62

63

64

65

66

67

68

69

70

71

72

73

74

75

76

77

78

79

80

81

82

83

84

85

86

87

88

89

90

91

92

93

94

95

96

97

98

99

100

4-5. PRINTED WIRING BOARDS - POWER SUPPLY/DISPLAY/MD SECTION -

• See page 25 for semiconductor lead layouts.

SEMICONDUCTOR LOCATION

Ref. No.	LOCATION
D01	G - 21
D905	J - 9
D906	I - 7
D907	J - 8
D908	J - 8
D909	J - 7
D910	J - 8
D911	H - 9
D912	H - 10
D913	H - 9
D914	H - 10
D915	J - 10
D916	J - 10
IC1	F - 13
IC01	F - 17
IC02	F - 18
IC03	G - 19
IC701	D - 7
IC702	E - 8
IC703	D - 8
IC704	B - 8
IC901	J - 6
IC902	J - 6
IC903	I - 9
IC904	I - 10
PH01	H - 17
PH02	H - 18
PH03	I - 21
PH04	E - 21
Q01	F - 18
Q02	F - 18
Q701	D - 6
Q702	D - 6
Q703	D - 6
Q704	D - 6
Q705	D - 6
Q706	D - 6
Q707	D - 5
Q708	D - 5
Q709	D - 5
Q710	D - 5
Q901	J - 8

- Note:
- : indicated a lead wire mounted on the component side.
 - : parts mounted on the conductor side.
 - : Through hole.
 - ▨ : Pattern from the side which enables seeing.
 - ▨ (red) : Pattern of the rear side.

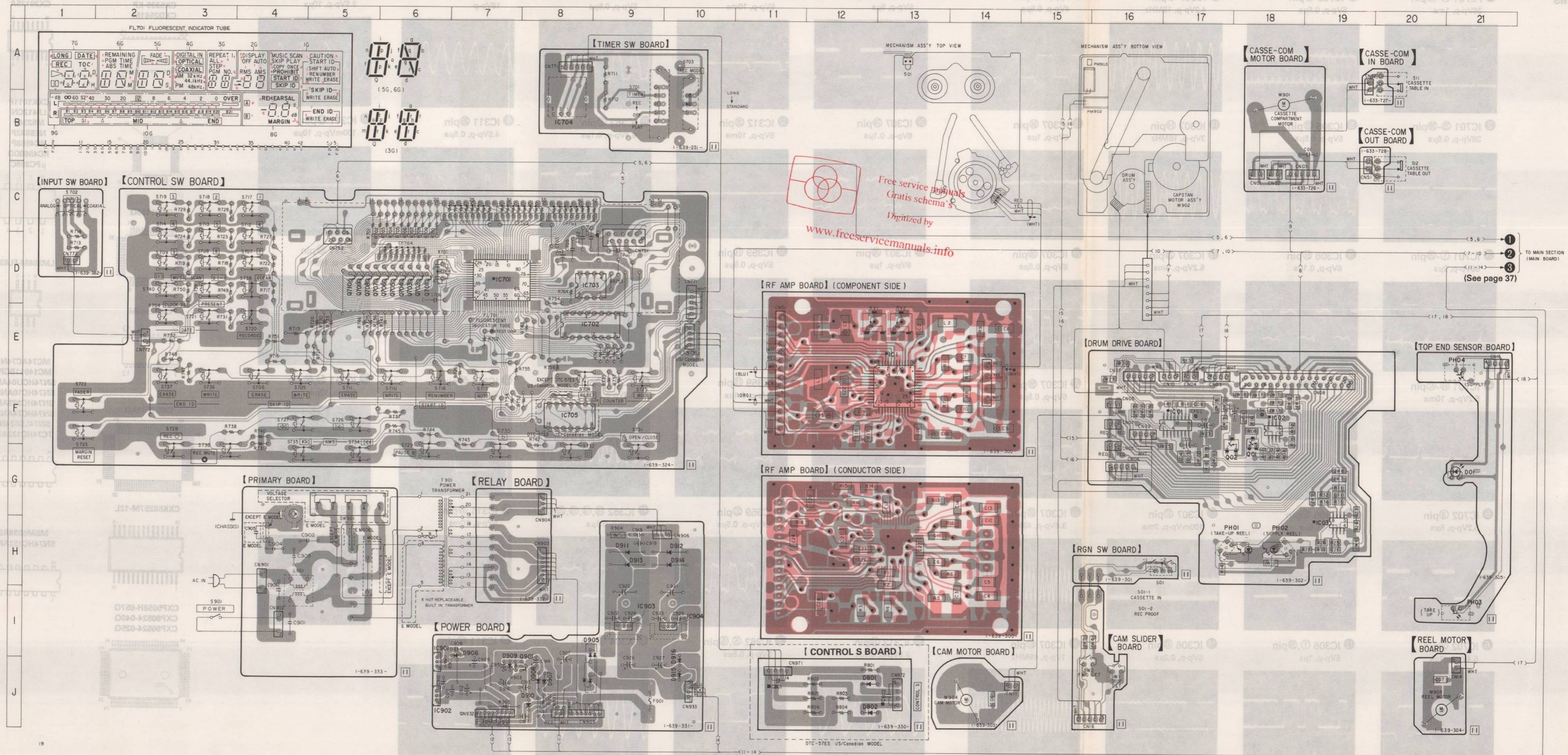

Free service manuals
Gratis schema's
Digitized by
www.freesevicemanuals.info

TO MAIN SECTION (MAIN BOARD)
①
②
③
(See page 37)

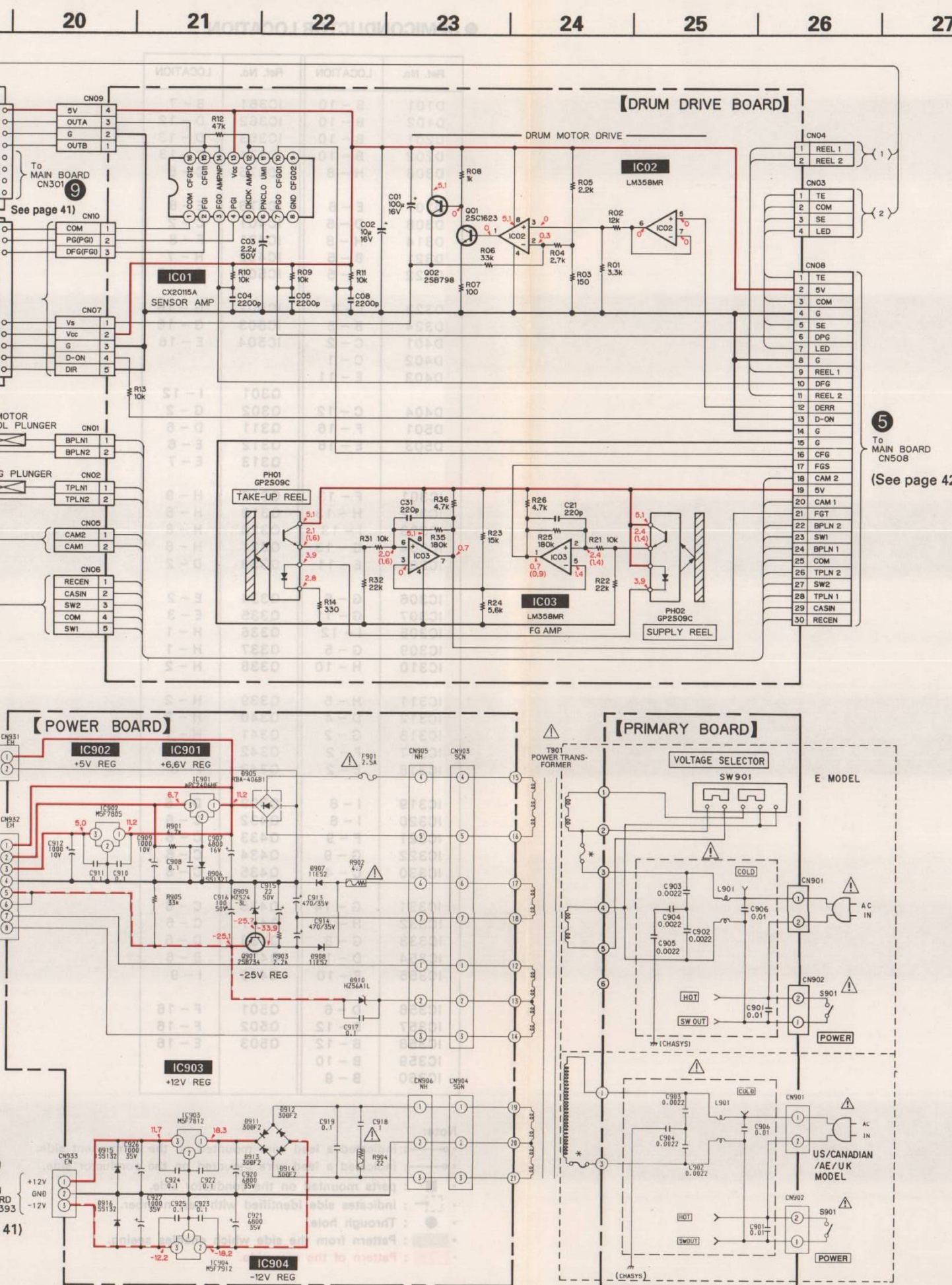
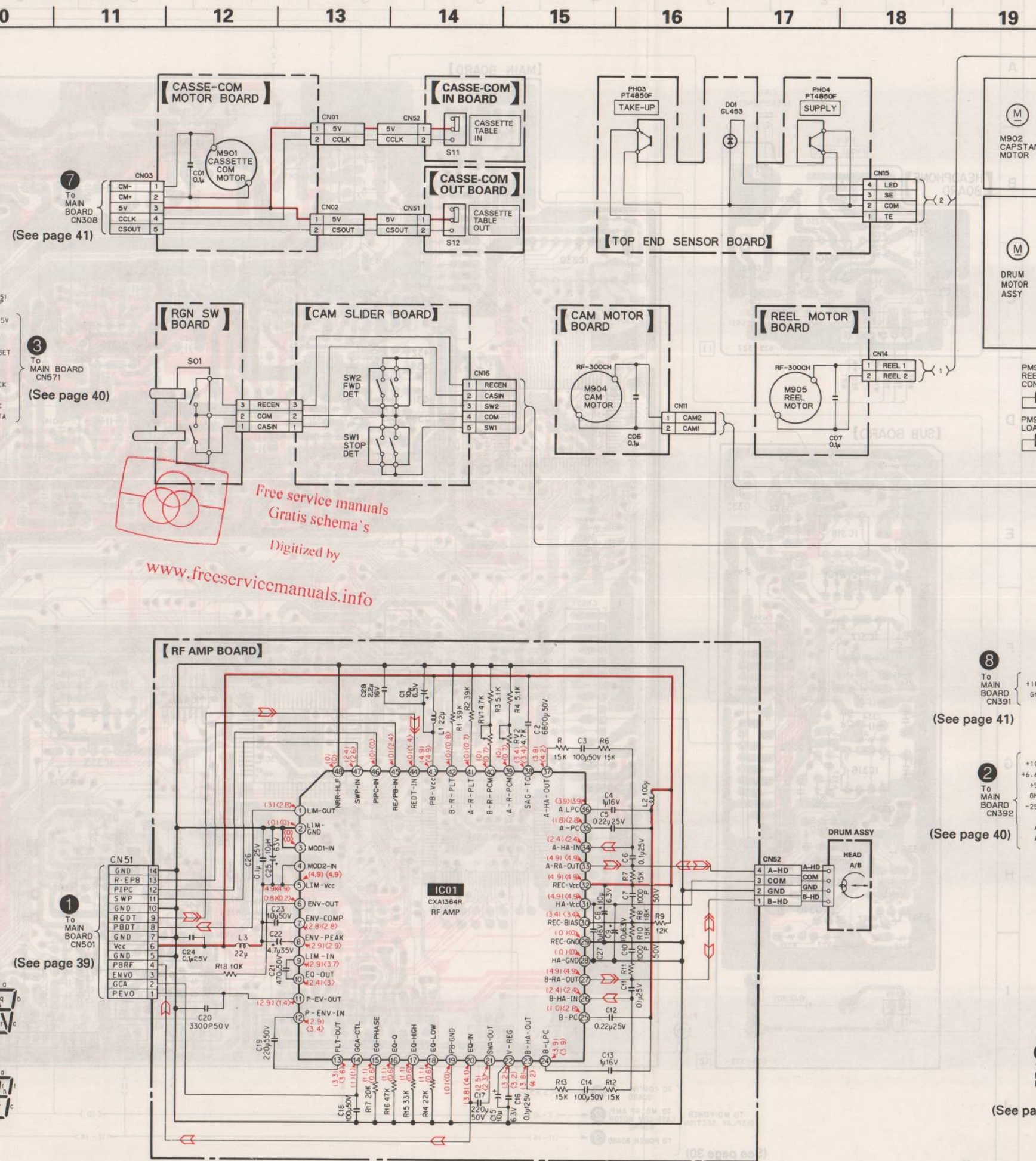
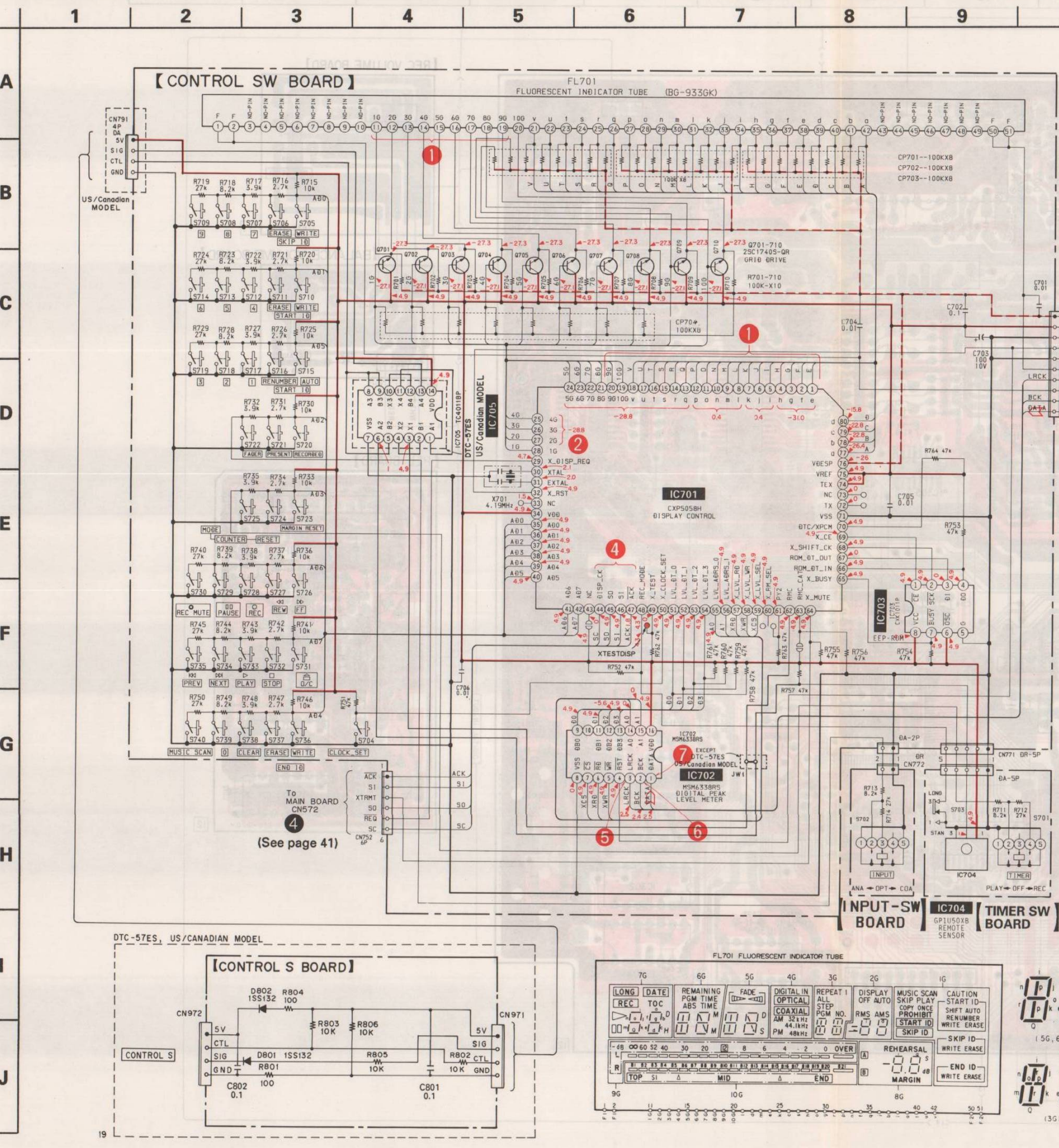

Free service manuals
Gratis schema's
Digitized by
www.freeservicemanuals.info

Note:

- All capacitors are in μF unless otherwise noted. pF: μF 50WV or less are not indicated except for electrolytics and tantalums.
- All resistors are in ohms, 1/4W or less unless otherwise noted.
- Δ : internal component.
- $\text{---}\text{---}\text{---}$: Fuse resistor

The components identified by mark Δ or dotted line with mark Δ are critical for safety. Replace only with part number specified.

Les composants identifiés par une marque Δ sont critiques pour la sécurité. Ne les remplacer que par une pièce portant le numéro spécifié.

- $\text{---}\text{---}\text{---}$: B + Line.
- $\text{---}\text{---}\text{---}$: B - Line.
- $\text{---}\text{---}\text{---}$: adjustment for repair.
- Voltage are dc with respect to ground under no-signal (STOP) conditions.
- no mark: Stop
- () : PLAY
- < > : REC
- Volts are taken with a VOM (input impedance 10M Ω). Voltage variations may be noted due to normal production tolerances.
- Circled numbers refer to waveforms.
- Waveforms are taken with an oscilloscope. Voltage variations may be noted due to normal production tolerances.
- Signal path
- $\text{---}\text{---}\text{---}$: PB
- $\text{---}\text{---}\text{---}$: REC

4-7. PRINTED WIRING BOARDS – MAIN SECTION –

● SEMICONDUCTOR LOCATION

Ref. No.	LOCATION	Ref. No.	LOCATION
D101	B - 10	IC361	B - 7
D102	B - 10	IC362	D - 12
D201	B - 10	IC363	D - 13
D306	H - 8	IC375	C - 8
D307	E - 6	IC376	E - 8
D308	D - 6	IC401	C - 2
D314	H - 8	IC431	F - 8
D321	B - 5	IC432	H - 7
D322	B - 5	IC501	G - 15
D323	I - 8	IC502	G - 16
D324	B - 5	IC503	G - 16
D401	C - 2	IC504	E - 16
D402	C - 1		
D403	E - 11	Q301	I - 12
D404	C - 12	Q302	G - 2
D501	F - 16	Q311	D - 6
D503	E - 16	Q312	E - 6
		Q313	E - 7
IC301	F - 13	Q318	H - 9
IC302	H - 13	Q319	H - 8
IC303	I - 13	Q320	H - 8
IC304	G - 13	Q321	H - 8
IC305	E - 11	Q333	D - 2
IC306	G - 6	Q334	E - 2
IC307	G - 11	Q335	E - 3
IC308	I - 12	Q336	H - 1
IC309	G - 5	Q337	H - 1
IC310	H - 10	Q338	H - 2
IC311	H - 5	Q339	H - 2
IC312	D - 4	Q340	H - 2
IC316	G - 2	Q341	H - 1
IC317	F - 2	Q342	E - 2
IC318	E - 2	Q343	I - 8
IC319	I - 8	Q399	D - 6
IC320	I - 8	Q432	C - 6
IC321	F - 9	Q433	C - 6
IC322	G - 9	Q434	C - 6
IC330	C - 4	Q435	C - 6
IC331	G - 14	Q436	C - 6
IC332	H - 14	Q437	C - 6
IC333	G - 8	Q438	D - 6
IC354	D - 10	Q439	B - 6
IC355	E - 10	Q440	I - 9
IC356	D - 6	Q501	F - 16
IC357	B - 12	Q502	F - 16
IC358	B - 12	Q503	E - 16
IC359	B - 10		
IC360	B - 9		

- Note:**
- — : indicated a lead wire mounted on the component side.
 - — : indicated a lead wire mounted on the conductor side.
 - : parts mounted on the conductor side.
 - : indicates side identified with part number.
 - : Through hole.
 - : Pattern from the side which enables seeing.
 - : Pattern of the rear side.

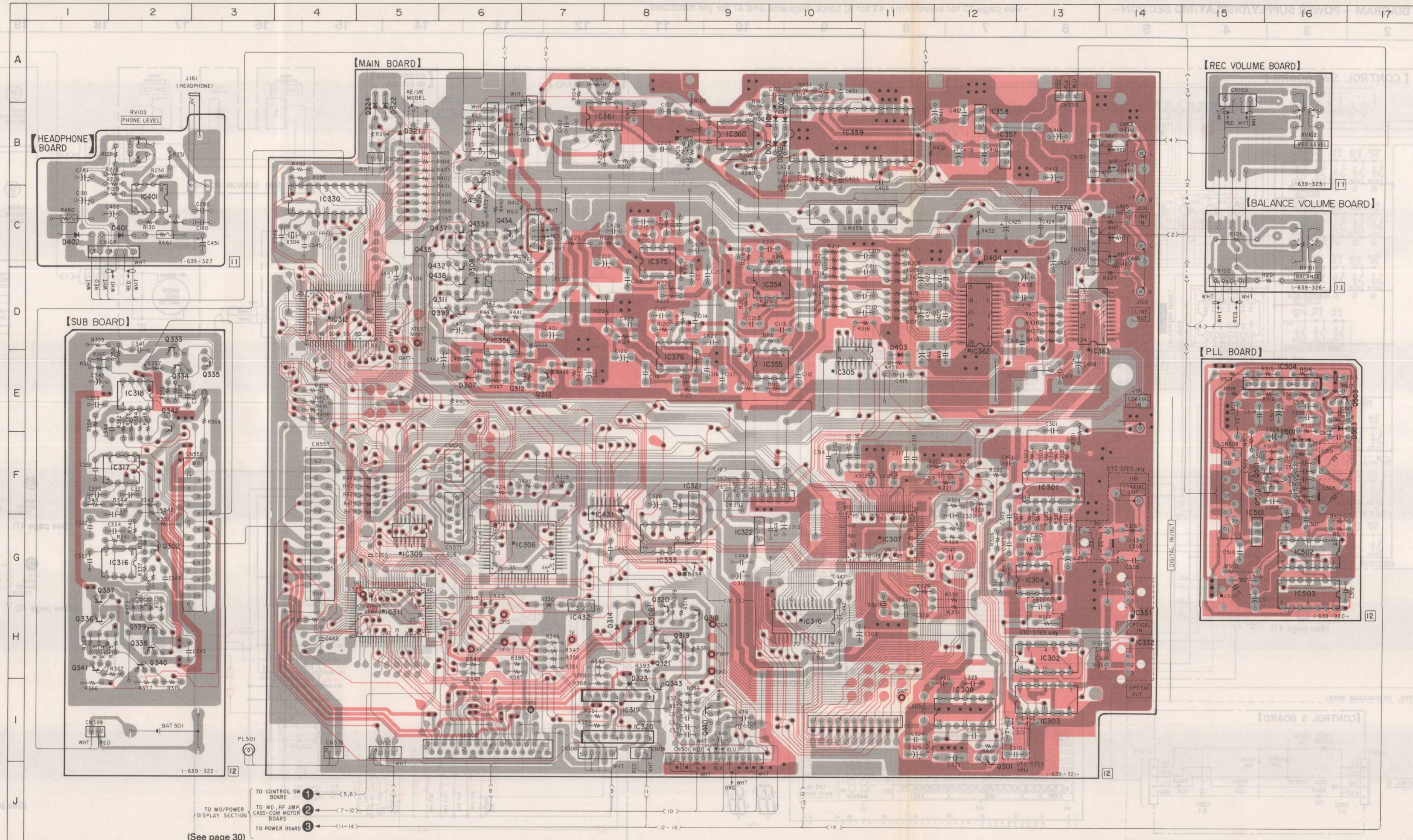

(See page 30)

4-8. SCHEMATIC DIAGRAM - MAIN SECTION - See page 23 for waveforms, 43 for IC block diagrams and 47 for pin functions.

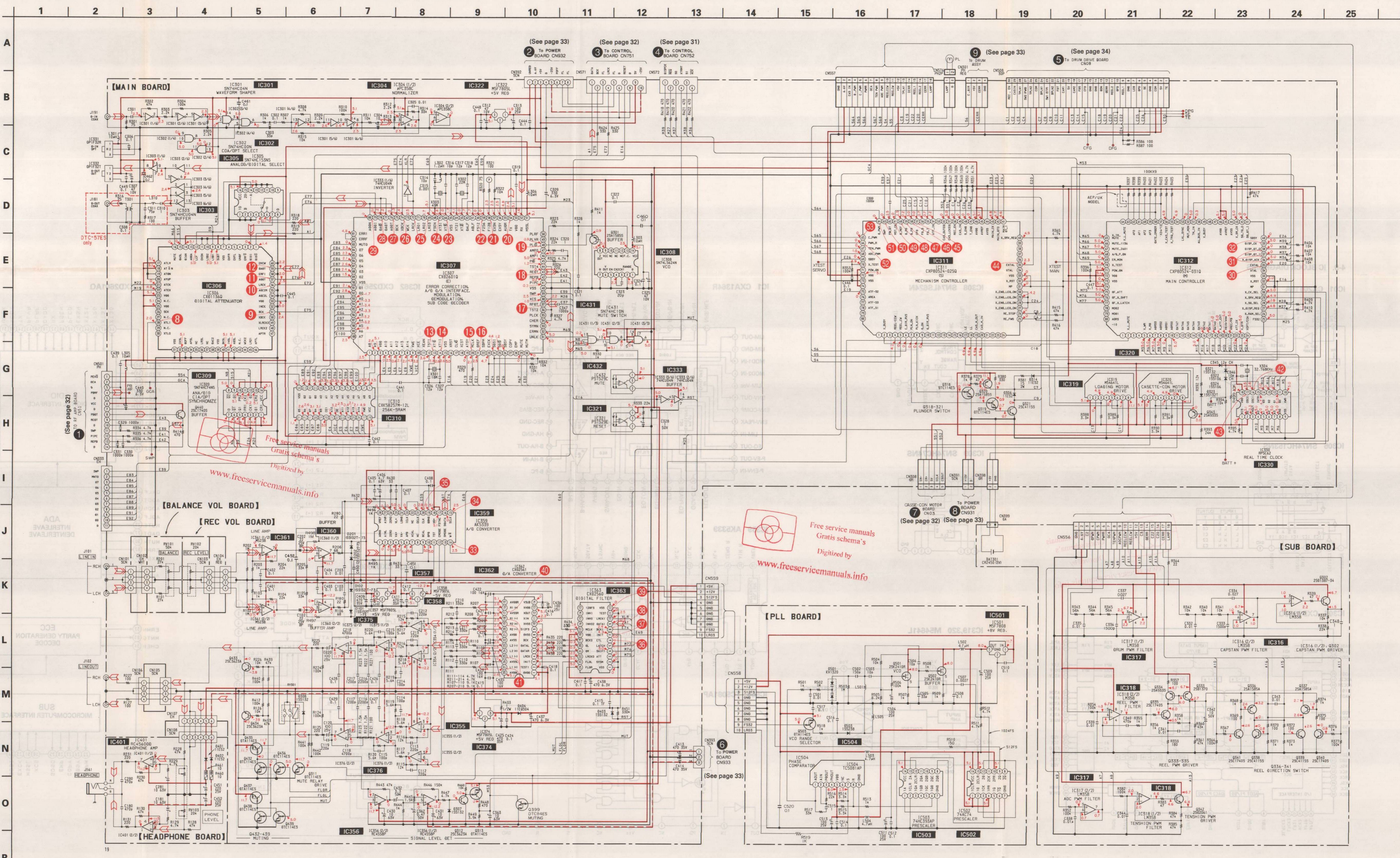

Note:

- All capacitors are in μF unless otherwise noted. pF: μF 50VW or less are not indicated except for electrolytics and tantalums.
- All resistors are in ohms, 1/4W or less unless otherwise noted.
- \square : Fuse resistor

The components identified by mark Δ or dotted line with mark Δ are critical for safety. Replace only with part number specified.

Les composants identifiés par une marque Δ sont critiques pour la sécurité. Ne les remplacer que par une pièce portant le numéro spécifié.

- : B + Line.
- : B - Line.
- \square : adjustment for repair.
- Voltage are dc with respect to ground under no-signal (STOP) conditions.
- no mark : Stop
- Voltages are taken with a VOM (input impedance 10M Ω).
- Voltage variations may be noted due to normal production tolerances.
- Circled numbers refer to waveforms.
- Waveforms are taken with an oscilloscope.
- Voltage variations may be noted due to normal production tolerances.
- Signal path
- \square : PB
- \square : REC

4-9. IC BLOCK DIAGRAMS

IC01 CX20115A

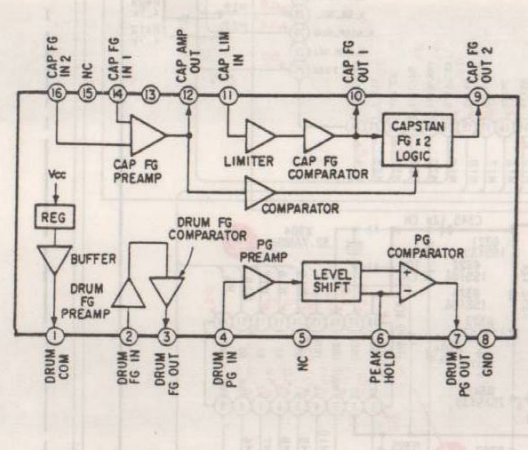

IC308 SN74LS624N

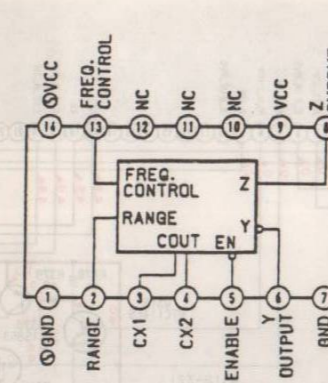

IC1 CXA1364R

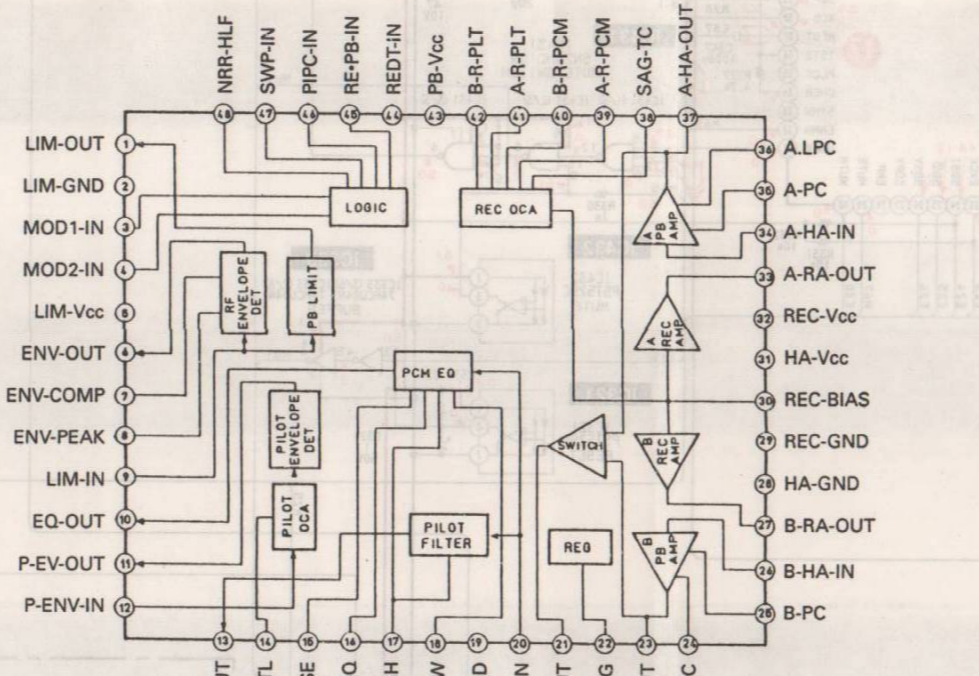

IC362 CXD2561M

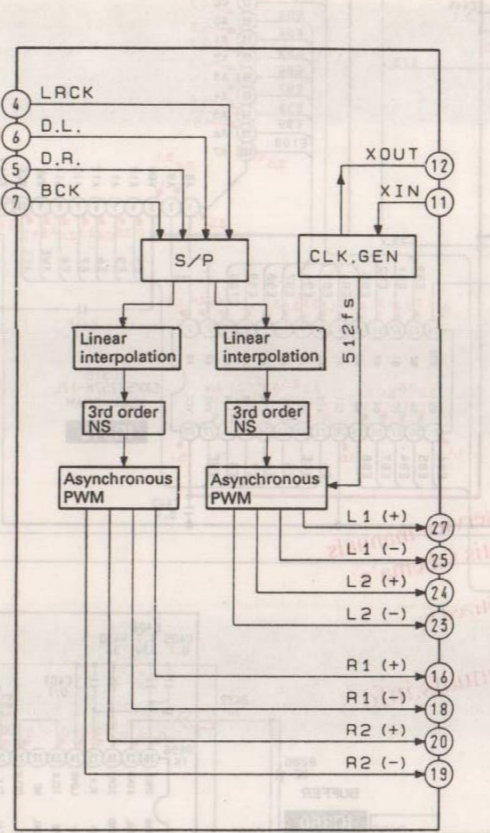

IC307 CXD2601AQ

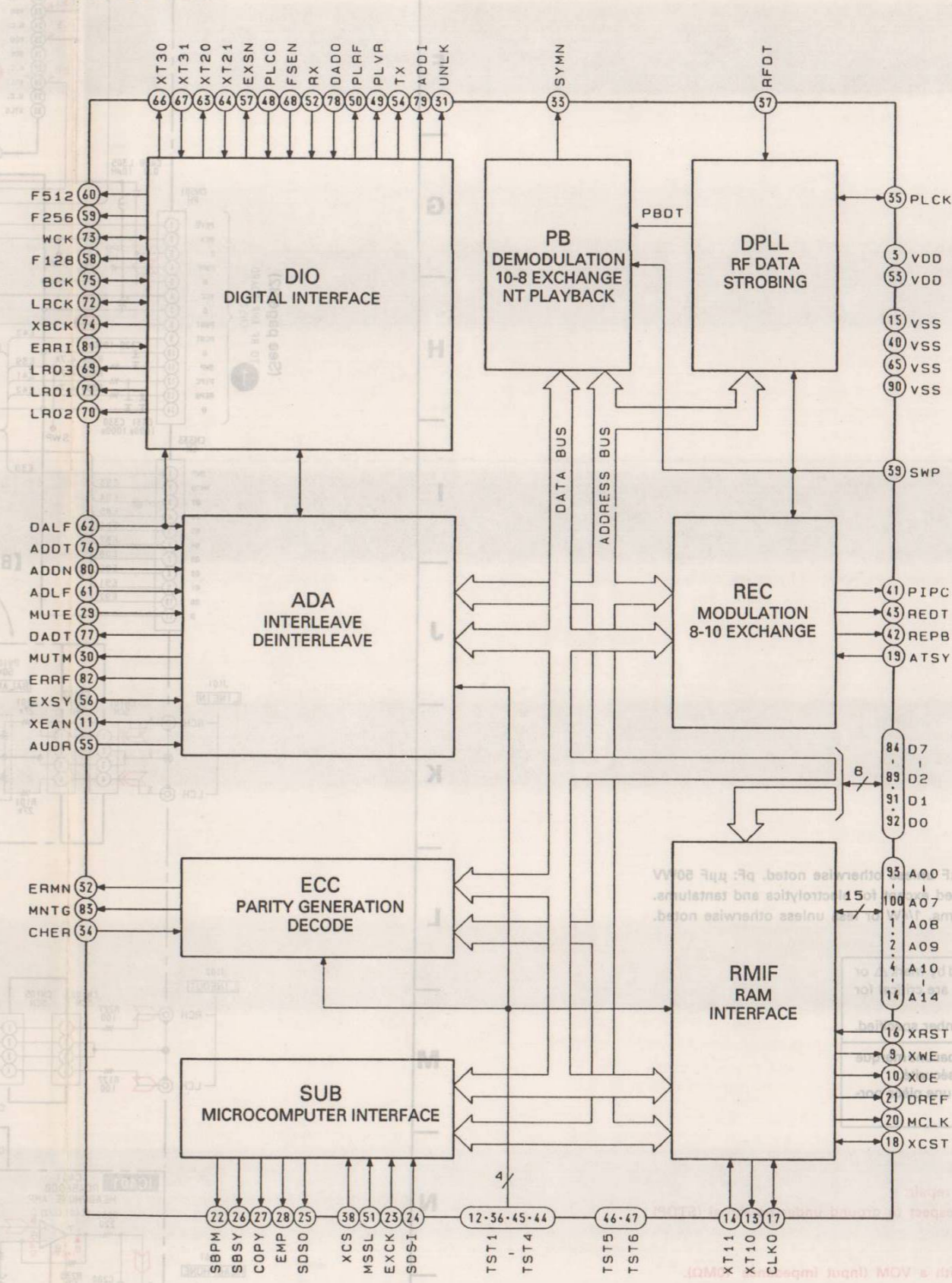

IC305 SN74HC153NS

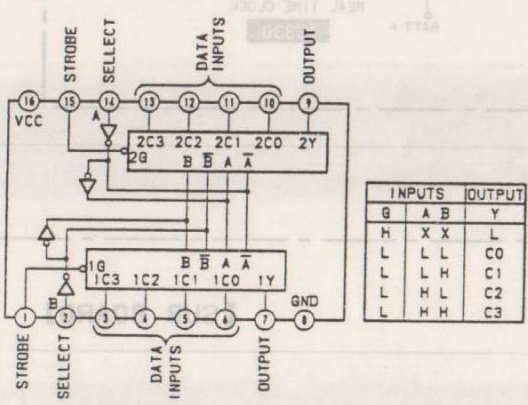

IC309 SN74HC74NS

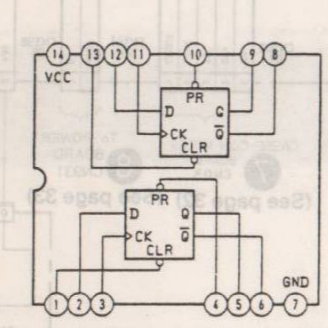

IC359 AK5339

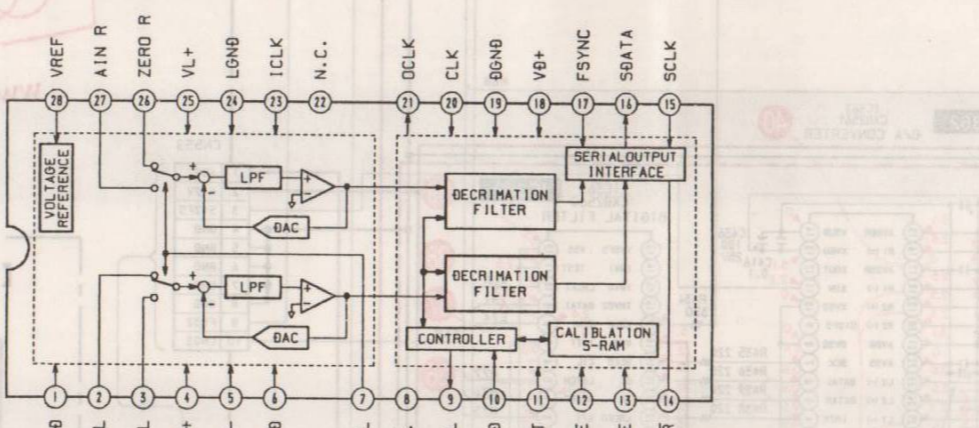

IC363 CXD2560M

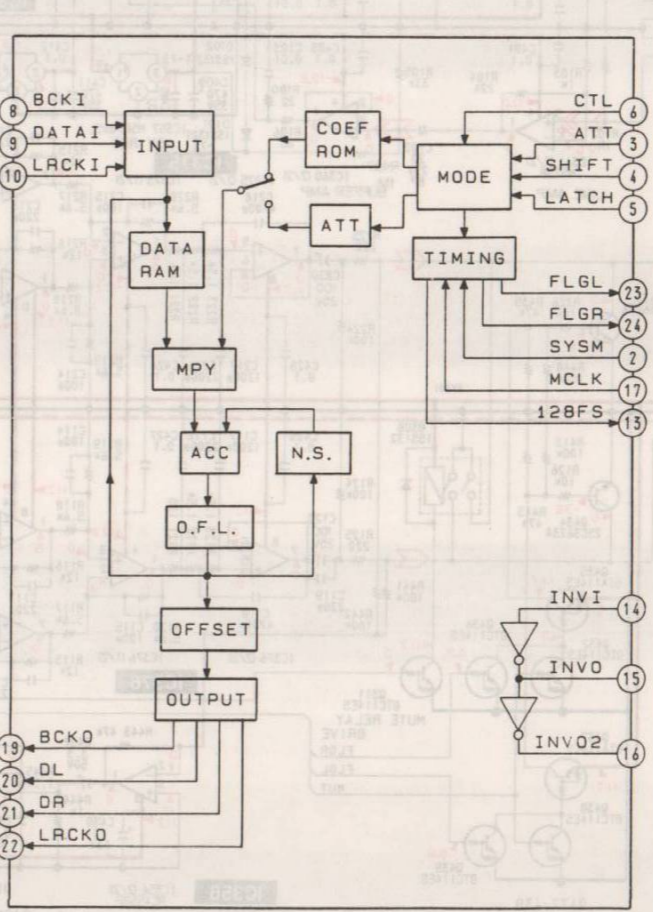

IC319,320 M54641L

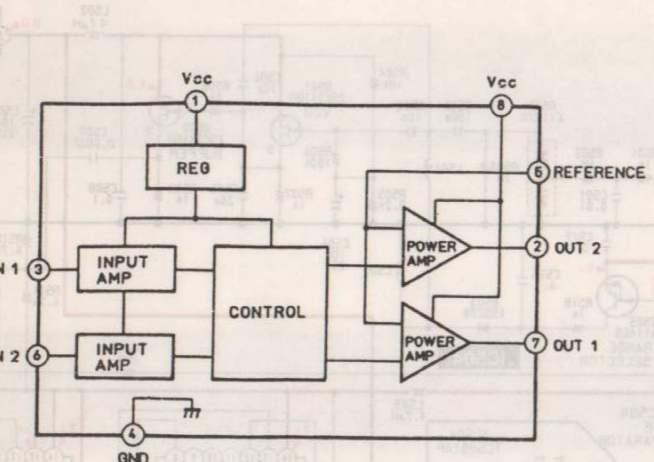

IC504 TC5081AP

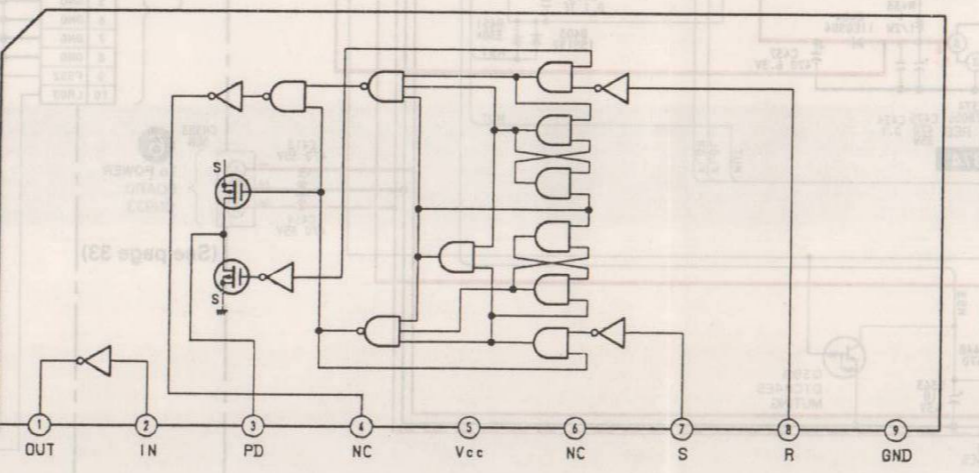

IC306 CXD1136Q

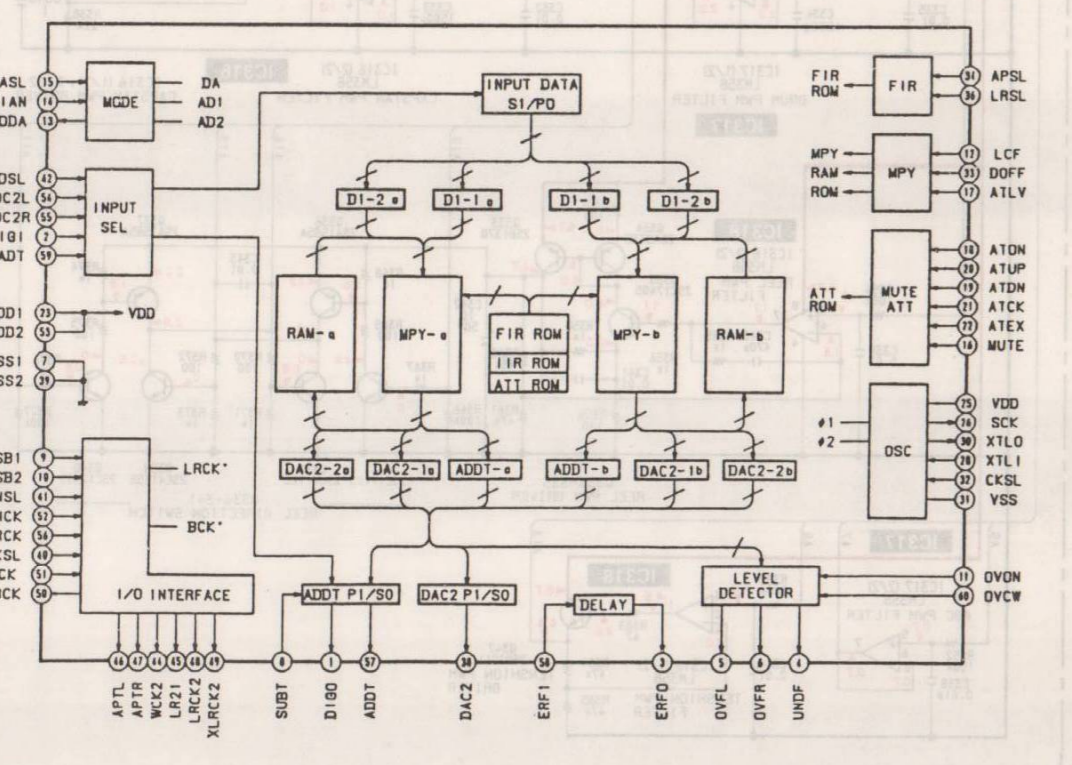

Free service manuals
Gratis schema's
Digitized by
www.freeservicemanuals.info

4-10. PIN FUNCTIONS

IC306 Digital Attenuator (CXD1136Q)

The captioned attenuator is used with the equipment as a digital attenuator in fade IN and fade OUT.

Pin No.	Pin Name	I/O	Description
1	DIGO	O	Serial data output synchronized with BCK (complement of 2)
2	DIGI	I	Serial data input synchronized with BCK (complement of 2)
3	ERFO	O	Signal output for discriminating whether or not DADT has interpolated data
4	UNDF	O	Detect result for ADDT L, R channel data of -54 dB or less ("L": -54 dB or less)
5	OVFL	O	Detect result for ADDT L channel overflow ("L": overflow detected)
6	OVFR	O	Detect result for ADDT R channel overflow ("L": overflow detected)
7	VSS		GND
8	SUBT	I	Selects whether subcode or 18-bit data is output to ADDT and DIGO ("H" or open: 18-bit data output, "L": subcode output)
9	LSB1	I	MSB/LSB fast switching for DADT, ADDT, DIGI, DIGO ("H" or open MSB fast, L: LSB fast)
10	LSB2	I	MSB/LSB fast switching for DAC2, ADC2L (ADC2R) ("H" or open MSB fast, L: LSB fast)
11	OVON	I	Overflow detect result on/off ("H" or open: OVFL, OVFR output valid, L: OVFL, OVFR fixed "H")
12	LCF	I	Low-cut filter on/off ("H" or open: on)
13	ADDA	O	"H" in AD mode (DASL = DIAN = "L")
14	DIAN	I	Sets AD and DA modes
15	DASL	I	Sets AD and DA modes
16	MUTE	I	Soft muting on/off ("H": mute on)
17	ATLV	I	Digital volume range setting ("H" or open: 0 - -60, -∞ dB, "L": +12 - -48, ∞ dB)
18	ATON	I	Digital volume on/off ("H" or open: off)
19	ATDN	I	Digital volume level down
20	ATUP	I	Digital volume level up
21	ATCK	I	Digital volume level setting clock and soft muting external clock
22	ATEX	I	Soft muting operation clock selection ("H" or open: internal clock, "L": ATCK)
23	VDD	—	Power supply (+5 V)
24	NC		
25	VDD'	—	Oscillator circuit power supply (+5 V)
26	SCK	O	Oscillator clock output
27	NC		
28	XTLI	I	Crystal connector and clock input pin
29	NC		
30	XTLO	O	Crystal connector pin (24.576 MHz oscillation frequency possible)
31	VSS'	—	Oscillator circuit GND
32	CKSL	I	Oscillator clock division selection ("H" or open: no division, "L": 1/2 division)
33	NC		
34	NC		
35	DOFF	I	DAC2 digital offset on/off ("H" or open: on)
36	APSL	I	Aperture correction filter coefficient selection (not valid in AD mode) ("H" or open: correction active)
37	LRSL	I	L, R channel phase difference correction selection ("H" or open: correction active)
38	DAC2	O	Serial data output to 2-times oversampling DA converter (complement of 2)
39	VSS	—	Power supply (+5 V)
40	BKSL	I	LRCK, BCK input timing switch ("H" or open: LRCK change point and BCK leading edge synchronized, "L": LRCK change point and BCK trailing edge synchronized)
41	INSL	I	DADT, DIGI, ADC2L (ADC2R) data incorporation clock selection ("H" or open: BCK, "L": INCK)
42	ADSL	I	ADC2L, ADC2R data selection ("H" or open: ADC2L, "L": ADC2L and ADC2R switched by LRCK2)
43	NC		
44	WCK2	O	Clock equivalent to 4fs
45	LR21	O	DAC2 L, R channel discrimination signal in I ² S format

Pin No.	Pin Name	I/O	Description
46	APTL	O	Aperture signal
47	APTR	O	Aperture signal
48	LRCK2	O	DAC2, ADC2L (ADC2R) L, R channel discrimination signal (equivalent to 2fs) ("L": L channel, "H": R channel)
49	XLCK2	O	LRCK2 inverted output
50	XBCK	O	BCK inverted output
51	BCK	I	Clock equivalent to 64fs for DADT, ADDT, DIGI, DIGO data incorporation
52	INCK	I	DADT, DIGI, ADC2L (ADC2R) data incorporation clock
53	VDD	—	Power supply (+5 V)
54	ADC2L	I	Serial data input from 2-times oversampling AD converter (complement of 2)
55	ADC2R	I	Serial data input from 2-times oversampling AD converter (complement of 2)
56	LRCK	I	DADT, ADDT, DIGI, DIGO L, R channel discrimination signal (fs) ("L": L channel, "H": R channel)
57	ADDT	O	Serial data output synchronized with BCK (complement of 2)
58	ERFI	I	Signal input for discriminating whether or not DADT has interpolated data (complement of 2)
59	DADT	I	Serial data input synchronized with BCK (complement of 2)
60	OVCW	I	Clock input which determines detect time for OVFL, OVFR and UNDF

IC307 DAT Signal Processor (CXD2601Q)

This processor is an LSI to process recording and playback signals of the R-DAT system, in a single chip and provided with digital PLL, modem, error correction circuit, digital I/O, RAM control circuit, etc.

Pin No.	Pin Name	I/O	Description
1, 2	A08, A09	I/O	RAM address A08, A09
3	VDD	—	5 V
4-6	A10-A12	I/O	RAM address A10-A12
7, 8	A13, A14	O	RAM address A13, A14
9	XWE	O	RAM write enable signal
10	XOE	O	RAM output enable signal
11	XEAN	O	External addressing bus interrupt enable signal
12	TST1	I	Test pin (normally "L")
13	XT1O	O	18.816 MHz crystal oscillator output
14	XT1I	I	18.816 MHz crystal oscillator input
15	VSS	—	GND
16	XRST	I	Reset pin (normally "H")
17	CLKO	I/O	18.816 MHz clock output
18	XCST	I/O	SYEK (internal system clock) generation CLKO division timing signal
19	ATSY	I	ATF sync signal input
20	MCLK	O	9.408 MHz clock output
21	DREF	O	Drum servo reference signal
22	SBPM	O	Discrimination signal determining whether the subcode I/O clock (EXCK) is accepted ("L": accept, "H": ignore)
23	EXCK	I	Subcode I/O data transfer clock (DUTY50)
24	SDSI	I	Subcode serial data input
25	SDSO	O	Subcode serial data output
26	SBSY	O	Subcode I/O sync signal
27	COPY	O	Copy data output
28	EMP	O	Emphasis data output
29	MUTE	I	Mute pin
30	MUTM	O	Mute discrimination signal ("H": muted)
31	UNLK	O	RX PLL lock discrimination signal ("H": locked)
32	ERMN	O	Detects presence or absence of RF ("H": RF present, "L" during REC)

Pin No.	Pin Name	I/O	Description
33	SYMN	O	C1 check result for RF ("H": OK)
34	CHER	I	Signal for discriminating whether C2 is 1 or 2 times (C2 → C1 → C2 or C1 → C2) ("H": 1 time, "L": 2 times)
35	PLCK	I/O	RF PLL clock output
36	TST2	I	Test pin (normally "L")
37	RFDT	I	RF signal input
38	XCS	I	Subcode I/O chip select ("L": select)
39	SWP	I	RF switching pulse ("L": A-CH, "H": B-CH)
40	VSS	—	GND
41	PIPC	O	REC data PILOT/PCM discrimination signal ("H": PILOT, during playback: always "L")
42	REPB	O	Record/playback switching signal ("H": record)
43	REDT	O	Recording signal output, fixed "L" during playback
44	TST4	I	Test pin (normally "L")
45	TST3	O	RX APLL PD output (comparator output)
46	TST5	I	RX APLL oscillator cell amp input
47	TST6	O	RX APLL oscillator cell amp inverted output
48	PLCO	I	RX APLL external VCO clock input
49	PLVR	O	RX APLL comparison signal when external comparator is active (Vin) Not in use
50	PLVF	O	RX APLL comparison signal when external comparator is active (Rin) Not in use
51	MSSL	I	Master/slave setting ("H": master (fixed with the equipment), "L": slave)
52	RX	I	Digital input
53	VDD	—	5 V
54	TX	O	Digital output
55	AUDR	I	Audio mode/data recorder mode setting ("H": audio mode, "L": data recorder mode)
56	EXSY	I/O	Complete copy sync signal (25/3 - 100/3 Hz)
57	EXSN	I/O	Complete copy sync signal (25/3 - 100/3 Hz)
58	F128	I/O	128fsCK (normal)/256fsCK (×2) (DUTY50)
59	F256	O	256fsCK (normal)/512fsCK (×2) (DUTY50)
60	F512	O	512fsCK (normal)/512fsCK (×2) (DUTY50)
61	ADLF	I	Signal for discriminating whether ADDT serial data is MSB first or LSB first ("H": LSB first)
62	DALF	I	Signal for discriminating whether DADT serial data is MSB first or LSB first ("H": LSB first)
63	XT20	O	22.5792 MHz crystal oscillator output
64	XT21	I	22.5792 MHz crystal oscillator input
65	VSS	—	GND
66	XT30	O	49.152 MHz crystal oscillator output (24.576 MHz in B mode)
67	XT31	I	49.152 MHz crystal oscillator input (24.576 MHz in B mode)
68	FSEN	I	F128, BCK, LRCK input/output switch ("H": output)
69	LR03	O	LR02 inversion
70	LR02	O	LRCK 16BCK delay signal
71	LR01	O	LRCK 15BCK delay signal
72	LRCK	I/O	fs (normal)/2fs (×2) ("L": L-CH, "H": R-CH)
73	WCK	I/O	2fs (normal)/4fs (×2) (input mode only for testing)
74	XBCK	O	BCK inversion
75	BCK	I/O	64fs (normal)/128fs (×2)
76	ADDT	I	Serial AD data (complement of 2)
77	DADT	O	Serial DA data (complement of 2)
78	DADO	I	Digital output (DA) data input (normally connected to DADT)
79	ADDI	O	Digital input (AD) data output (normally connected to ADDN)
80	ADDN	I	Digital input (DA) data input
81	ERRI	I	Digital output V-FLAG data input (normally connected to ERRF)
82	ERRF	O	Signal output for discriminating whether or not DADT has interpolated data ("H": interpolated data)

Pin No.	Pin Name	I/O	Description
83	MNTG	O	Error correction status monitor trigger
84-89	D7-D2	I/O	RAM data bus D7-D2
90	VSS	—	GND
91, 92	D1, D0	I/O	RAM data bus D1, D0
93-100	A00-A07	I/O	RAM address A00-A07

IC311 Mechanism/Servo Micon (CXP80524-025Q)

The mechanical deck servo systems are controlled by the captioned micon according to instructions from the main micon (IC312).

Pin No.	Pin Name	I/O	Connected to	Description
1		O		Not in use
2	<u>BUSY</u>	O	Main Micon	Busy (Active "L") to the Main Micon
3		O		Not in use
4	REEL_CCW	O	Mechanism	Reel motor CCW ("L": RVS direction) } *1
5	REEL_CW	O	Mechanism	Reel motor CW ("H": FWD direction)
6	C_DIR_RVS	O	Mechanism	Capstan Direction ("L": FWD, "H": RVS)
7	PLN_ON	O	Mechanism	Plunger On
8	PLN_KICK	O	Mechanism	Plunger Kick
9	D_ON	O	Mechanism	Drum On ("H": The drum is revolving)
10	D_DIR_RVS	O	Mechanism	Not in use
11-16		O		Not in use
17	LE	O	Mechanism	Loading Motor Eject } *2
18	LL	O	Mechanism	Loading Motor Load
19	CAS_M_OUT	O	Mechanism	Cassette control motor Out } *3
20	CAS_M_IN	O	Mechanism	Cassette control motor In
21-24		—		Not in use
25	RE_FWD	I	Mechanism	Encoder SW2 } *4
26	RE_STOP	I	Mechanism	Encoder SW1
27-30	<u>END_LED_ON</u>	O	Mechanism	End sensor ON Illuminated upon "L" (rectangular wave of about 1kHz). It is not output unless a cassette is mounted ("H").
31	MP	I		Microprocessor mode selected (the equipment is fixed at "L").
32	<u>RST</u>	I		System Reset (low active)
33	Vss	—		Power terminal (GND)
34	XTAL	O		System Clock Output
35	EXTAL	I	CXD2601AQ	System Clock Input (9.408 MHz)
36-39		—		Not in use
40	X_SRV_REQ	I	Main Micon	Request for communication from the Main Micon
41	MAIN_DT_I	I	Main Micon	Serial Input from the Main Micon
42	MAIN_DT_O	O	Main Micon	Serial Output to the Main Micon
43	MAIN_CK	I	Main Micon	Serial Clock with the Main Micon
44	AVss	—		GND for A/D
45	AVref	—		Reference Voltage for A/D (+5 V)
46	AVdd	—		Power Supply for A/D (+5 V)
47	T_END	I	Mechanism	Take-up side end sensor input (analog) } Magnetic matter: 0V,
48	S_END	I	Mechanism	Supply side end sensor input (analog) } Leader tape: AC (*5)
49	CAS_IN	I	Mechanism	Cassette-in switch (S01). "H": Cassette is mounted.
50	REC_EN	I	Mechanism	Rec-enable switch (S01). "H": REC enabled.
51	CAS_LCKed	I	Mechanism	Casecon locked Upon completion of loading: "H"
52	CAS_OUTed	I	Mechanism	Casecon outed Upon completion of loading OUT: "H"
53		I		Not in use
54	ATF_IN	I	RF Amp	ATF PILOT input
55	FG_T	I	Mechanism	Reel FG (T Side) } 6/24Hz (Small reel diameter) -
56	FG_S	I	Mechanism	Reel FG (S Side) } 15/24Hz (Large reel diameter) (In SP FWD)
57	C_FG	I	Mechanism	Capstan FG SP: 674 Hz, LP: 337 Hz
58	D_FG	I	Mechanism	Drum FG 400 Hz: LP REC, 800 Hz: Other modes
59	D_PG	I	Mechanism	Drum PG } Other than LP REC: 800/24Hz
60	D_REF	I	CXD2601AQ	Drum Reference } In LP REC: 400/24Hz

Pin No.	Pin Name	I/O	Connected to	Description
61	MST_CK	I	CXD2601AQ	Master clock (9.408MHz)
62	PB_DT	I	RF Amp	PB Data input to create ATF Sync
63	SWP	O	CXD2601AQ	Switching Pulse "L": Ach, "H": Bch
64	D_PWM	O	Mechanism	PWM Out for Drum
65	C_PWM	O	Mechanism	PWM Out for Capstan
66	PWM_R	O	Mechanism	PWM Out for Reel
67	TEN_PWM	O	Mechanism	PWM Out for Tension Regulator Plunger
68	AGC_PWM	O	RF Amp	PWM Out for AGC
69	SBSY	I	CXD2601AQ	↓ of subsync is detected (XINT2).
70	TEST	I	Pull-up	Test Mode (active "L")
71	POW_DN	I		Not in use
72	Vdd	—		Power terminal (+5 V)
73	Vss	—		Power terminal (GND)
74		—		Not in use
75	ATF_S2	O	CXD2601AQ	ATF Sampling Pulse
76-80		—		Not in use

*1 Reel motor control

	CCW (counterclockwise)	CW (clockwise)
STOP (only in POWER ON)	L	L
FWD	L	H
RVS	H	L
Prohibit	H	H

*4 Encoder

RF-FWD	RE_STOP	Position
L	L	EJECT
L	H	STOP UNLD-STOP
H	L	FWD
H	H	STOP-FWD

*2 Loading motor control

	LE	LL
—	L	L
LOAD	L	H
EJECT	H	L
Brake	H	H

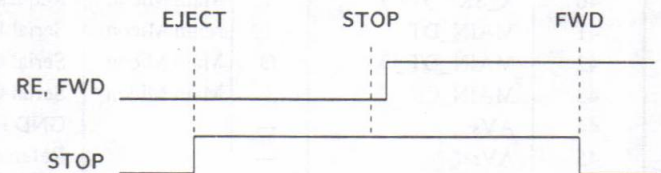

*3 Casecon motor control

	OUT	IN
—	L	L
IN	L	H
OUT	H	L
Brake	H	H

*5 End sensor

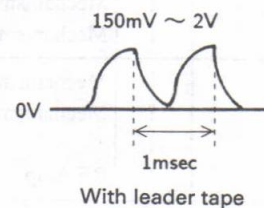

IC312 Main Micon (CXP80524-040Q)

This Micon generally controls the operation of the equipment while exchanging data with the display micon (IC701) and mechanism/servo micon (IC311) in serial communications, including the DAT signal processor (IC307), attenuator (IC306), clock (IC330), digital filter (IC363) and other IC.

Pin No.	Pin Name	I/O	Connected to	Description
1		O		Not in use
2	$\overline{\text{L_MUTE}}$	O	Line Out	Line Mute (Active "L")
3		O		Not in use
4		O		Not in use
5	$\overline{\text{WRT}}$	O	Clock IC	Write request (Active "L")
6	RD	O	Clock IC	Read request (Active "L")
7-10	ADRS_3-0	O	Clock IC	Address 3-0 (Address BUS)
11-14	DATA_7-4	I/O		DATA 7-4 (DATA BUS). Not in use with the equipment
15-18	DATA_3-0	I/O	Clock IC	DATA 3-0 (DATA BUS)
19	$\overline{\text{ATT_EXT}}$	O	CXD1136Q	Fade attenuator ck externally selected (Active "L")
20	$\overline{\text{DIG/ANA}}$	O	CXD1136Q	Fade In/Out switching for DIG ("L")/ANA ("H")
21	$\overline{\text{REC/PB}}$	O	CXD1136Q	Fade In/Out REC switching for ("L")/PB ("H")
22	ATT_CK	O	CXD1136Q	Clock for fade In/Out
23	$\overline{\text{DTR}}$	O	CXD2601AQ	Audio use ("H")/Data Recorder use ("L"). Becomes "L" in after-recording and searching.
24	$\overline{\text{OPT/COA}}$	O	Digital I/O	Switching for Optical ("L")/Coaxial ("H")
25	FS32	O	1Bit DAC	"H" upon Fs = 32kHz. "L" for others.
26	$\overline{\text{RAM_SEL}}$	O		Not in use
27	$\overline{\text{DISP_REQ}}$	O	Display Micon	Request for communication with the Display Micon ("L" Active)
28	$\overline{\text{SD_REQ}}$	O	CXD2601AQ	Request for communication with CXD2601 ("L" Active)
29	$\overline{\text{SRV_REQ}}$	O	Mechanism Micon	Request for communication with the Mechanism Micon ("L" Active)
30	$\overline{\text{CLOCK_SEL}}$	O	Clock IC	Clock IC chip selected
31	MP	I		Microprocessor mode selected (fixed at "L" with the equipment)
32	$\overline{\text{RST}}$	I		System Reset ("L" Active)
33	Vss	—		Power terminal (GND)
34	XTAL	O		System Clock Output
35	EXTAL	I	CXD2601AQ	System Clock Input (9.048 MHz)
36	$\overline{\text{DISP_ACK}}$	I	Display Micon	ACKnowledge (Active "L")
37	DISP_DT_I	I	Display Micon	Serial Input
38	DISP_DT_O	O	Display Micon	Serial Output
39	DISP_CK	I	Display Micon	Serial clock
40	SBSY	I	CXD2601AQ	Subcode sync
41	SR_DT_IN	I	}CXD2601AQ & Mechanism Micon	Serial Data In
42	SR_DT_OUT	O		Serial Data Out
43	$\overline{\text{SR_CK}}$	I/O		Serial clock (In/Out) to Sub Code Interface
44	AVss	—		GND for A/D
45	AVref	—		Reference Voltage for A/D (+5 V)
46	AVdd	—		Power Supply for A/D (+5 V)
47		I		Not in use
48		I		Not in use
49	$\overline{\text{BUSY}}$	I	Mechanism Micon	Mechanism servo micon Busy (Active "L")
50	AU_BUS_IN	I	Audio Bus	Not in use

Pin No.	Pin Name	I/O	Connected to	Description
51	TM_IN	I	Clock IC	TM_OUT for clock IC
52	MUT_MON	I	CXD2601AQ	Mute monitor (Active "H")
53	LVL_SYNC	I	Audio Block	Start ID is written by entering Level Sync Input audio.
54		I		Not in use
55	TRQ_TEST	I	Pull-up	Not in use
56	NO_CAS_TEST	I	Pull-up	Not in use
57	TIME_24/12	I	Pull-up	Time indication "H": 12 hours (AM, PM) "L": 24 hours display
58	DATE_ORDER	I	Pull-up	Order of DATA display "H": Year, month and day "L": Month, day and year
59-62	AF_3-0	I	Pull-up	Not in use
63		O		Not in use
64	L_MUTE	O	Pull-up	Line Mute (Active "L"). Not in use with the equipment
65	TR_MUTE	O	Line Out	Transistor Mute (Active "L")
66	MUTE_1136	O	CXD1136Q	Mute for CXD1136 (Active "H")
67	MUTE_2061	O	CXD2601AQ	Mute for CXD2601 (Active "H")
68	A_D_PWR_DWN	O	AK5339	A/D Converter Power Down Mode (Active "H"). The AD converter is turned OFF upon digital input/output.
69	ER_MON	I	CXD2601AQ	Error Monitor (Data Valid)
70	TEST	I	Pull-up	Test Mode (Active "L")
71	POW_DN	I	+5 V	Not in use
72	Vdd	—		Power terminal (+5V)
73	Vss	—		Power terminal (GND)
74		—		Not in use
75	D_F_ATT	O	CXD2560M	Communication line (Serial Data) with Digital Filter
76	D_F_SHIFT	O	CXD2560M	Communication line with Digital Filter (Shift Clock; shifted by ↓ and taken in by ↑)
77	D_F_LATCH	O	CXD2560M	Communication line (Latch Pulse) with Digital Filter
78, 79	MODE2, 1	O	CXA1364R	Mode Control of the RF amplifier
80		O		Not in use

IC330 Real Time Clock (RP5C62)

The Clock is an IC for clock and calendar and backed up by a lithium battery when the power supply to the set is OFF.

Pin No.	Pin Name	I/O	Description
1	CS	I	Chip select input. Active "L"
2	CE	I	Chip enable input. Active "H"
3	TMOUT	O	Interval output
4-7	A0-3	I	4 bit address input
8	RD	I	Read-out control input
9	Vss	—	Power terminal (GND)
10	WR	I	Write-in control input
11-14	D0-3	I/O	4 bit data input/output
15	INTR	O	Interrupt output. A 2048Hz signal is output here with the equipment.
16	OSCIN	I	Clock input (32.768kHz)
17	OSCOUT	O	Clock output
18	VDD	—	Power terminal (+5 V)

IC362 Pulse D/A Converter (CXD2561M)

The Converter is a small, high-performance 1 bit pulse D/A converter that provides 4 asymmetrical PWM wave outputs in each ch of L/R.

Pin No.	Pin Name	I/O	Description
1	DV _{DD}	—	Digital power supply
2	TEST	I	Test terminal. Normally fixed at "L."
3	INIT	I	Again synchronized at the buildup edge of the signal.
4	LRCKI	I	LRCK input
5	DRI	I	Rch data input
6	DLI	I	Lch data input
7	BCKI	I	BCK input
8	DV _{SS}	—	Digital GND
9	512Fs	O	512Fs output
10	XV _{SS}	—	Clock GND
11	XIN	I	X'tal oscillator input terminal (512Fs)
12	XOUT	O	X'tal oscillator output terminal
13	XV _{DD}	—	Clock power supply
14	V _{SUB}	—	Substrate. Connected to GND.
15	AV _{DD} R	—	Analog power supply
16	R1 (+)	O	Rch PLM output 1 (normal phase)
17	AV _{SS} R	—	Analog GND
18	R1 (-)	O	Rch PLM output 1 (reverse phase)
19	R2 (+)	O	Rch PLM output 2 (normal phase)
20	R2 (-)	O	Rch PLM output 2 (reverse phase)
21	AV _{DD}	—	Analog power supply
22	AV _{SS}	—	Analog GND
23	L2 (-)	O	Lch PLM output 2 (reverse phase)
24	L2 (+)	O	Lch PLM output 2 (normal phase)
25	L1 (-)	O	Lch PLM output 1 (reverse phase)
26	AV _{SS} L	—	Analog GND
27	L1 (+)	O	Lch PLM output 1 (normal phase)
28	AV _{DD} L	—	Analog power supply

IC363 Digital Filter (CXD2560M)

The Filter is a digital audio 8x oversampling digital filter with builtin L/R 2ch filter, noise shaping attenuator, soft muting deemphasis, etc.

Pin No.	Pin Name	I/O	Description
1	V _{SS}	—	Power terminal (GND)
2	SYSM	I	System mute input. Effective upon "H"
3	ATT	I	ATT data input in CTL "L." EMP input upon CLT "H."
4	SHIFT	I	Shift clock input upon CTL "L." FS32 input upon CTL "H."
5	LATCH	I	Latch clock input upon CTL "L." FS48 input upon CLT "H."
6	CTL	I	Pull-down in the IC. Direct input mode upon "H." Serial transfer mode upon "L."
7	INIT	I	Synchronized again at the buildup edge of the signal.
8	BCKI	I	BCK input
9	DATAI	I	Data input
10	LACKI	I	LRCK input
11	TEST	I	Test terminal. Fixed at "L" during normal use.
12	V _{SS}	—	Power terminal (GND)
13	128Fs	O	128Fs clock output
14	INVI	I	Inverter input
15	INVO	O	Inverter output
16	INVO2	O	Inverter output
17	MCLK	I	Master clock input (f=512Fs)
18	V _{DD}	—	Power terminal (+2 V)
19	BCKO	O	BCK output
20	DL	O	Lch data output
21	DR	O	Rch data output
22	LRCKO	O	LRCK output
23	FLGL	O	Lch \emptyset mute flag output
24	FLGR	O	Rch \emptyset mute flag output

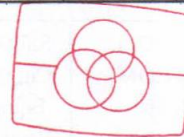

Free service manuals
Gratis schema's

Digitized by

www.friceservicemanuals.info

IC701 Display Micon (CXP5058H-657Q)

The Micon controls key input, FL tube display, remote control signal input, level meter (IC702) and EEP-ROM (IC703) according to instructions from the Main Micon (IC312).

Pin No.	Pin Name	I/O	Connected to	Description
1-18	e_v_SEG	O	FL tube FL701	FL Segment 'e'-'v'
19-28	10_1_G	O	FL tube FL701	FL Grid #10-#1
29	DSP_REQ	I	MAIN Micon	Communication request ("L" Active)
30	XTAL	—	Ceramic oscillator	
31	EXTAL	I	Ceramic oscillator	4.19MHz ceramic oscillator
32	RST	I		System Reset ("L" active)
33	NC	—		Not in use
34	Vdd	I		Power terminal (+5 V)
35-42	AD_0-7	I	Panel switch	Key input A/D converter input #0 - #7
43	NC	—		Not in use
44	DISP_CK	O	MAIN Micon	Shift clock
45	SO	O	MAIN Micon	Serial data OUT
46	SI	I	MAIN Micon	Serial data IN
47	DSP_ACK	O	MAIN Micon	Acknowledge (Active "L")
48	REC_MODE	I	S703	REC MODE "H": Standard, "L": Long
49	TEST	I	Pull-down	Test mode (Active "L")
50	CLOCK_SET	I	S704	CLOCK SET switch S704 (Active "L")
51-54	LVL_DT_0-3	I/O	Level Meter IC	Level Meter Data 0-3
55, 56	LVL_ADRS_0, 1	O	Level Meter IC	Level Meter Data 0, 1
57	LVL_RD	O	Level Meter IC	Level Meter Read Mode (Active "L")
58	LVL_WR	O	Level Meter IC	Level Meter Write Mode (Active "L")
59	LVL_SEL	O	Level Meter IC	Level Meter IC Select (Active "L")
60	RM_SEL	O	Open	External remote controller selected (not in use)
61	PY2	I	Pull-up	Not in use
62	RMC	I	Open	Not in use
63	RMC_CAT	I	Pull-down	Remote control category "L": DAT1, "H": DAT2. Fixed at "L" with the equipment.
64	TR_MUTE	I	IC431	Level meter mute (Active "L")
65	BUSY	I	EEPROM	BUSY signal (Active "L")
66	ROM_DT_IN	I	EEPROM	Data input
67	ROM_DT_OUT	O	EEPROM	Data output
68	SHIFT_CK	O	EEPROM	Shift clock
69	CE	O	EEPROM	Chip enable
70	DTC/XPCM	I	Pull-up	Equipment model discrimination input. Fixed at "H" with the equipment
71	Vss	I		Power terminal (GND)
72	TX	—	Open	Not in use
73	NC	—	Open	Not in use
74	TEX	—	+5 V	Not in use
75	Vref	I	+5 V	Analog board reference voltage
76	Vfdp	I	-25 V	FL display tube driving voltage
77-80	a_d_SEG	O	FL tube	FL Segment 'a'-'d'

SECTION 5

EXPLODED VIEWS

NOTE:

- -XX, -X mean standardized parts, so they may have some differences from the original one.
- Color Indication of Appearance Parts
Example:
KNOB,BALANCE(WHITE)...(RED)
 ↑ ↑
 Parts color Cabinet's color

- Items marked "*" are not stocked since they are seldom required for routine service. Some delay should be anticipated when ordering these items.
- The mechanical parts with no reference number in the exploded views are not supplied.
- Hardware(# mark) list is given in the last of this parts list.
- CND : Canadian model

The components identified by mark Δ or dotted line with mark Δ are critical for safety.
Replace only with part number specified.

Les composants identifiés par une marque Δ sont critiques pour la sécurité.
Ne les remplacer que par une pièce portant le numéro spécifié.

5-1. CABINET SECTION

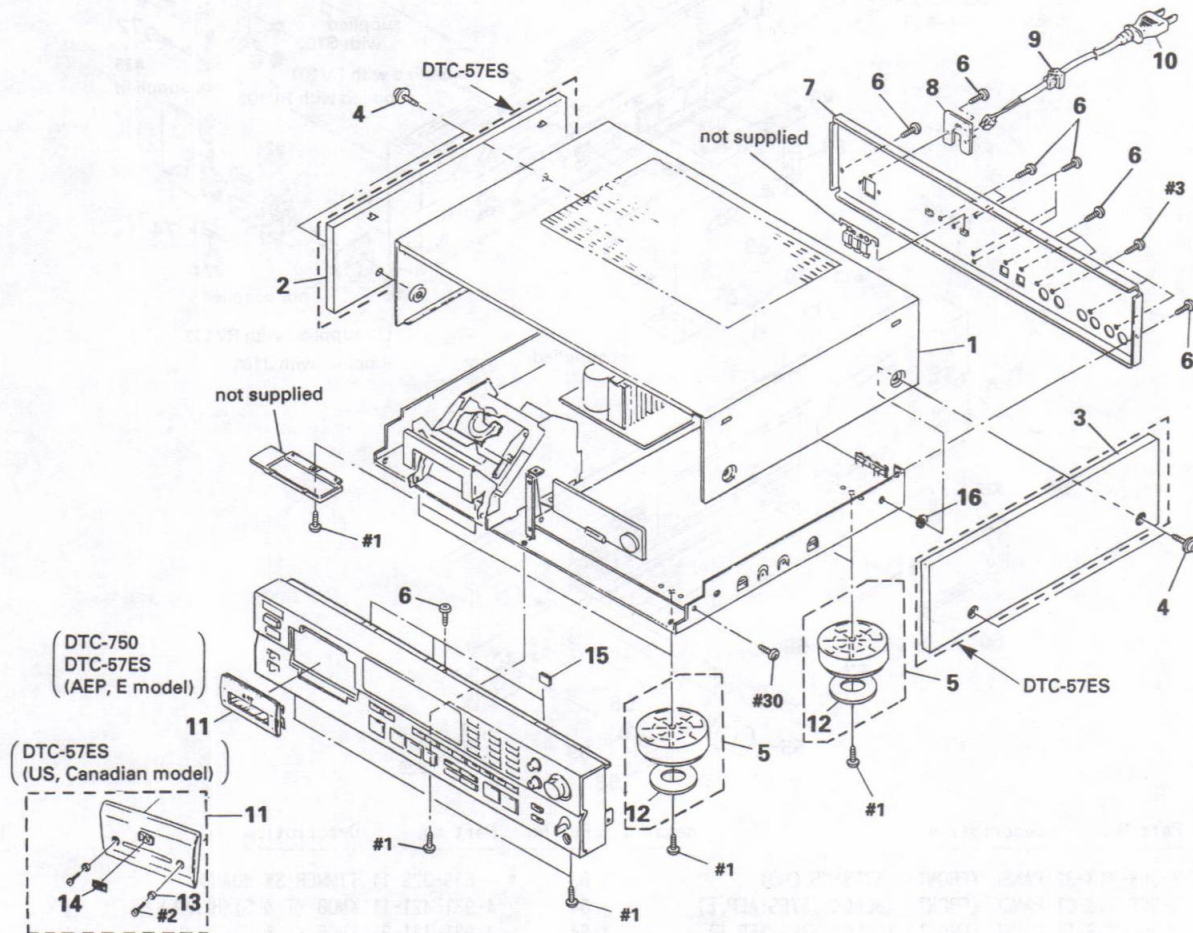

Ref. No.	Part No.	Description	Remarks	Ref. No.	Part No.	Description	Remarks
1	3-350-407-41	CASE (BLACK)		8	* 4-923-873-01	BRACKET, CORD STOPPER	
1	3-350-407-71	CASE (GOLD)		9	4-916-783-01	BUSHING, CORD (57ES:US, CND, E)	
2	* X-4919-027-2	PANEL (L) ASSY, SIDE (BLACK) (57ES)		9	* 3-703-244-00	BUSHING (2104), CORD (57ES:AEP/750)	
2	* X-3363-390-1	PANEL (L) ASSY, SIDE (GOLD) (57ES)		10	Δ 1-559-479-11	CORD, POWER (57ES:US, CND)	
3	* X-4919-028-2	PANEL (R) ASSY, SIDE (BLACK) (57ES)		10	Δ 1-559-297-31	CODE, POWER (57ES:E)	
3	* X-3363-389-1	PANEL (R) ASSY, SIDE (GOLD) (57ES)		10	Δ 1-575-912-11	CODE, POWER (57ES:AEP)	
4	4-933-446-01	SCREW (SIDE PANEL) (57ES)		10	Δ 1-575-913-11	CODE, POWER (750:UK)	
4	3-704-366-01	SCREW (CASE M3X8) (750)		10	Δ 1-575-695-11	CODE, POWER (750:US, CND)	
5	X-3304-938-2	FOOT ASSY (BLACK)		11	A-2003-671-A	PANEL (CASSETTE) ASSY (57ES:US, CND)	
5	X-4928-110-1	FOOT ASSY (GOLD)		11	A-2003-773-A	WINDOW ASSY, CASSETTE (BLACK) (57ES:AEP, E/750)	
6	3-703-685-21	SCREW (+BV 3X8)		11	A-2003-893-A	WINDOW ASSY, CASSETTE (GOLD) (57ES:AEP)	
7	* 3-368-712-51	PANEL, BACK (57ES:US, CND)		12	4-923-836-11	CUSHION	
7	* 3-368-712-21	PANEL, BACK (BLACK) (57ES:AEP)		13	4-884-635-00	BASE, ORNAMENTAL (57ES:US, CND)	
7	* 3-368-712-71	PANEL, BACK (GOLD) (57ES:AEP)		14	4-936-615-01	PLATE (DAT LOGO), ORNAMENTAL	
7	* 3-368-712-42	PANEL, BACK (57ES:E)		15	3-831-441-XX	CUSHION, SPEAKER	
7	* 3-368-712-11	PANEL, BACK (750:US, CND)		16	3-942-525-01	BLIND (1), KNOB	
7	* 3-368-712-31	PANEL, BACK (750:UK)					

5-3. CHASSIS SECTION

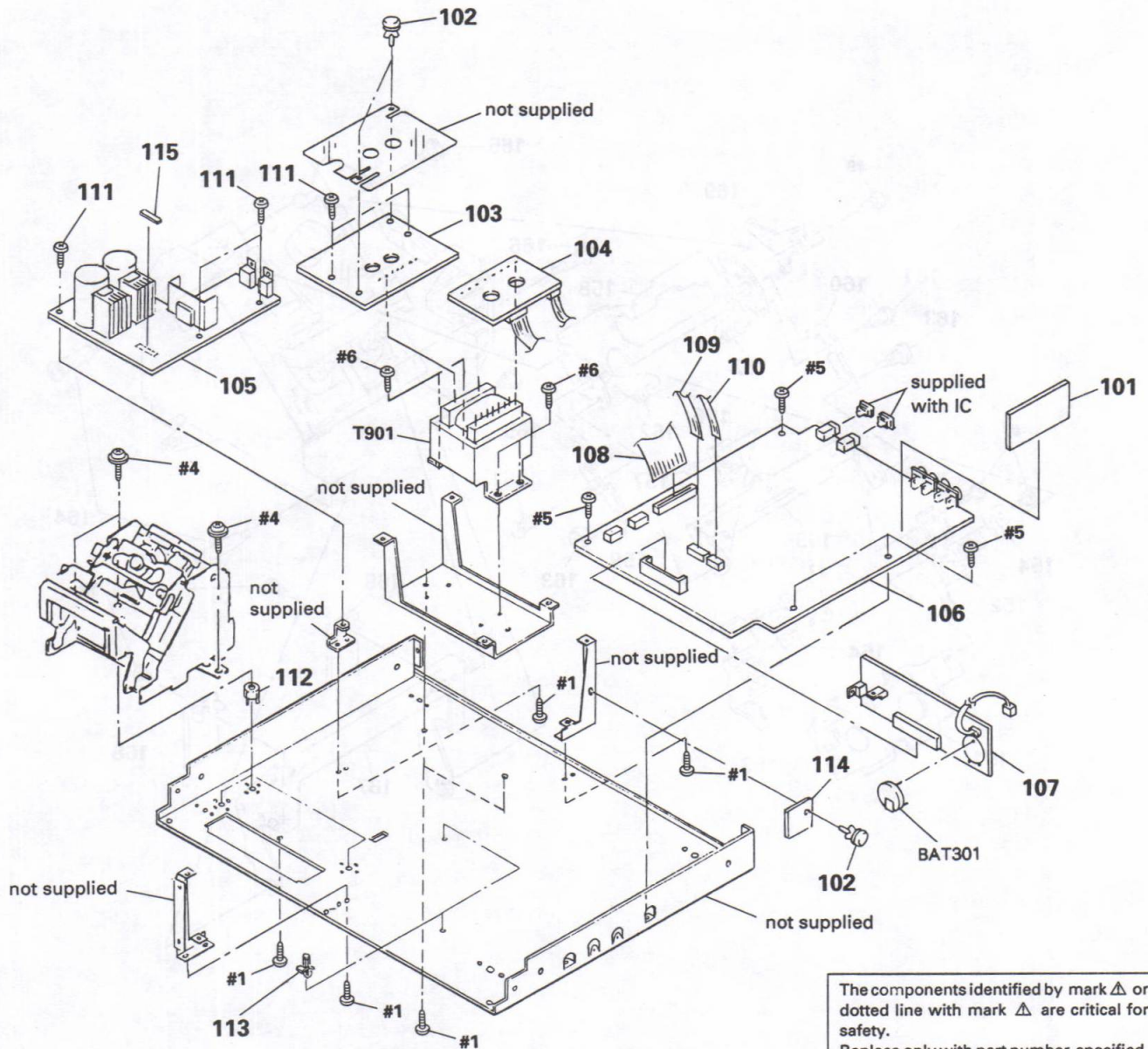

The components identified by mark Δ or dotted line with mark Δ are critical for safety.
Replace only with part number specified.

Les composants identifiés par une marque Δ sont critiques pour la sécurité.
Ne les remplacer que par une pièce portant le numéro spécifié.

Ref. No.	Part No.	Description	Remarks	Ref. No.	Part No.	Description	Remarks
101	* 1-639-920-11	PLL BOARD		109	1-590-916-11	WIRE, FLAT TYPE (10 CORE)	
102	4-812-134-00	RIVET NYLON, 3.5		110	1-590-914-11	WIRE, FLAT TYPE (6 CORE)	
103	* 1-639-333-11	PC BOARD, PRIMARY		111	4-886-821-11	SCREW, S TIGHT, +PTTW 3X6	
104	* 1-639-332-11	RELAY BOARD		112	3-368-709-01	HOLDER (MD)	
105	* A-2006-463-A	POWER BOARD, COMPLETE		113	* 3-670-570-00	SPACER, SUPPORT	
106	* A-2006-572-A	MAIN BOARD, COMPLETE (57ES:US, CND, E)		114	* 1-639-330-11	CONTROL (S) BOARD (57ES:US, CND)	
106	* A-2006-614-A	MAIN BOARD, COMPLETE (57ES:AEP)		115	3-701-947-15	LABEL (T2.5A), FUSE (57ES:AEP, E/750:UK)	
106	* A-2006-681-A	MAIN BOARD, COMPLETE (750:US, CND)		BAT301	Δ 1-528-229-11	BATTERY, LITHIUM CR-2450	
106	* A-2006-682-A	MAIN BOARD, COMPLETE (750:UK)		T901	Δ 1-450-556-11	TRANSFORMER, POWER (US, CND)	
107	* A-2006-553-A	SUB BOARD, COMPLETE		T901	Δ 1-450-557-11	TRANSFORMER, POWER (57ES:AEP/750:UK)	
108	1-590-915-11	WIRE, FLAT TYPE (30 CORE)		T901	Δ 1-450-558-11	TRANSFORMER, POWER (57ES:E)	

5-4. MECHANISM SECTION 1

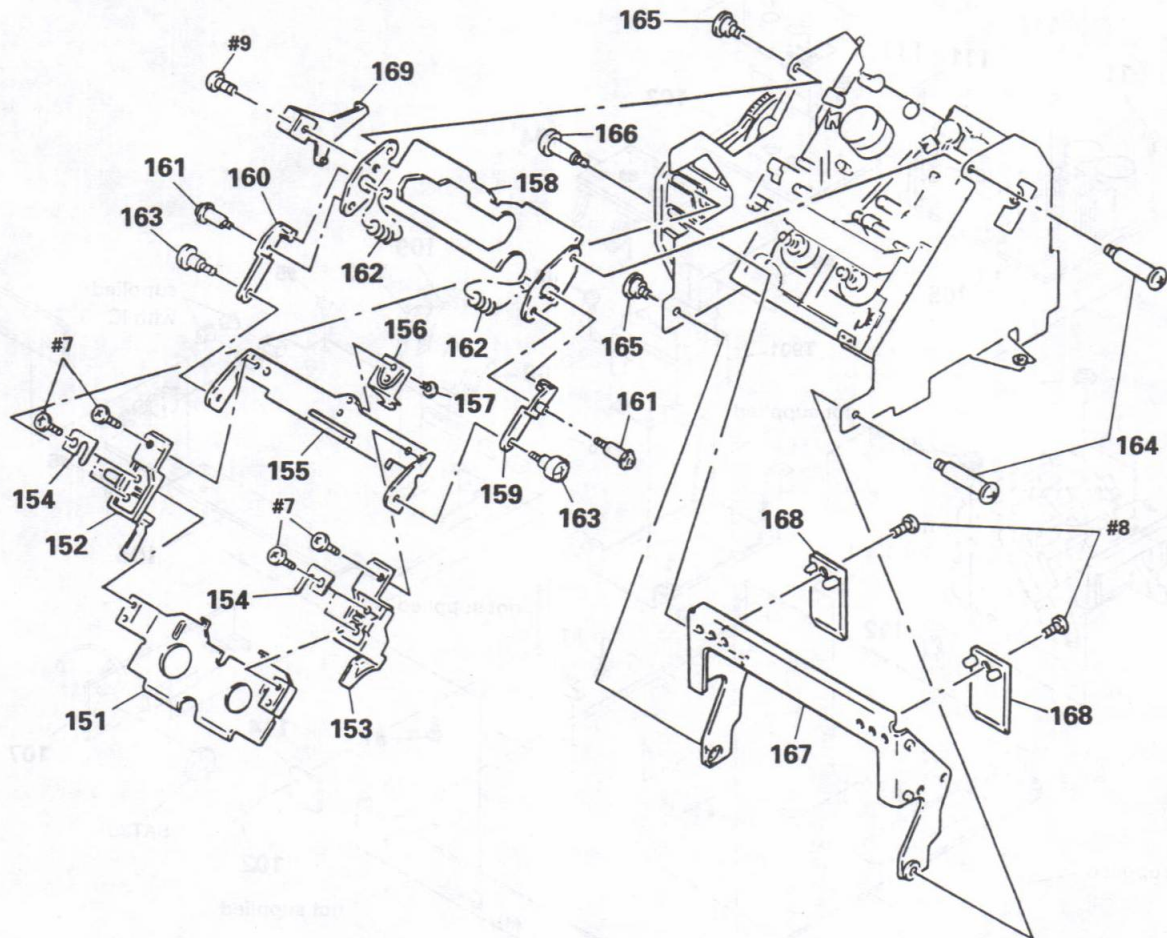

Ref. No.	Part No.	Description	Remarks	Ref. No.	Part No.	Description	Remarks
151	4-931-476-01	HOLDER (LOWER)		161	4-918-991-01	SCREW, STEP	
152	4-931-484-01	HOLDER (C-LEFT)		162	3-537-214-00	SPRING, COMPRESSION	
153	4-931-486-01	HOLDER (C-RIGHT)		163	3-312-161-00	SCREW, STEP, PRECISION	
154	3-366-308-01	SPRING (SIDE), PLATE		164	4-931-463-01	SCREW (STEP)	
155	* 4-931-485-01	HOLDER (C-INNER)		165	2-236-956-00	SCREW, STEP	
156	4-931-461-01	SPRING (CENTER), LEAF		166	4-931-471-01	SCREW (STEP)	
157	3-352-517-01	SCREW (M2X2.5)		167	4-931-474-01	HOLDER (WINDOW)	
158	* 3-369-235-01	PLATE, FULCRUM		168	4-931-469-01	PLATE, ORNAMENTAL	
159	4-931-481-01	ARM (LIMITER L)		169	* X-4919-020-1	JOINT ASSY	
160	4-931-473-01	ARM (LIMITER R)					

5-5. MECHANISM SECTION 2

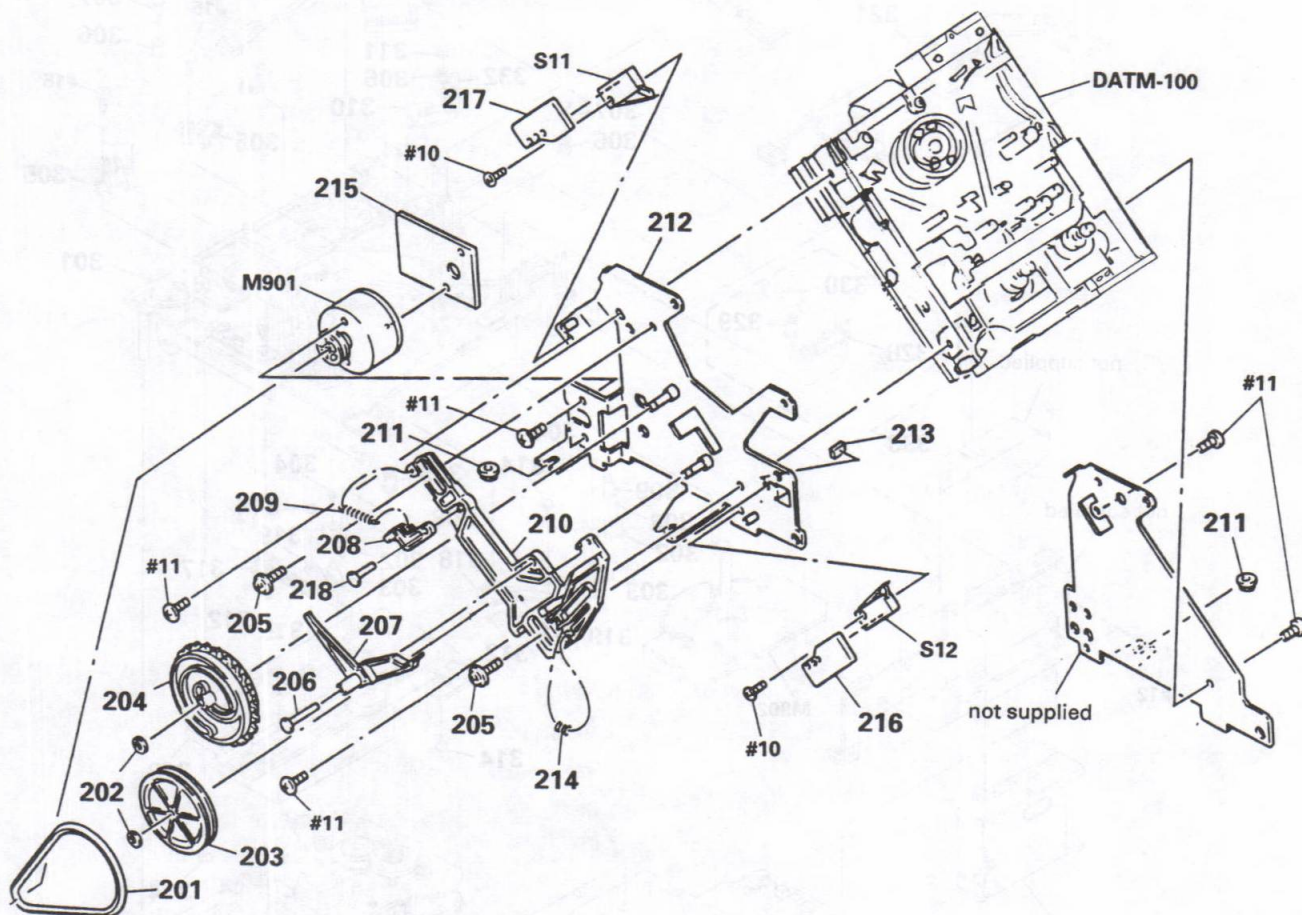

Ref. No.	Part No.	Description	Remarks	Ref. No.	Part No.	Description	Remarks
201	4-931-470-01	BELT (DRIVING)		212	* X-4919-023-1	PLATE ASSY, SIDE	
202	3-307-948-21	WASHER, NYLON		213	9-911-863-XX	SPACER	
203	4-931-459-01	PULLEY		214	3-537-215-00	SPRING, COMPRESSION	
204	4-931-477-01	GEAR (CAM)		215	* 1-639-646-11	MOTOR BOARD	
205	4-932-336-01	SCREW (STEP)		216	* 1-639-647-11	SW (IN) BOARD	
206	4-931-468-01	SHAFT (PRESS FITTING)		217	* 1-639-648-11	SW (OUT) BOARD	
207	4-931-490-01	LEVER (LINK)		218	4-936-626-01	SHAFT (ARM PRESS FITTING)	
208	4-931-460-01	ARM (SLIDER)		M901	A-2003-448-A	MOTOR ASSY	
209	3-549-810-00	SPRING, TENSION		S11	1-570-975-11	SWITCH, SLIDE (CASSETTE TABLE OUT)	
210	4-931-492-01	SLIDER (CAM)		S12	1-572-247-11	SWITCH, SLIDE (CASSETTE TABLE IN)	

5-6. MECHANISM SECTION 3 (DATM-100)

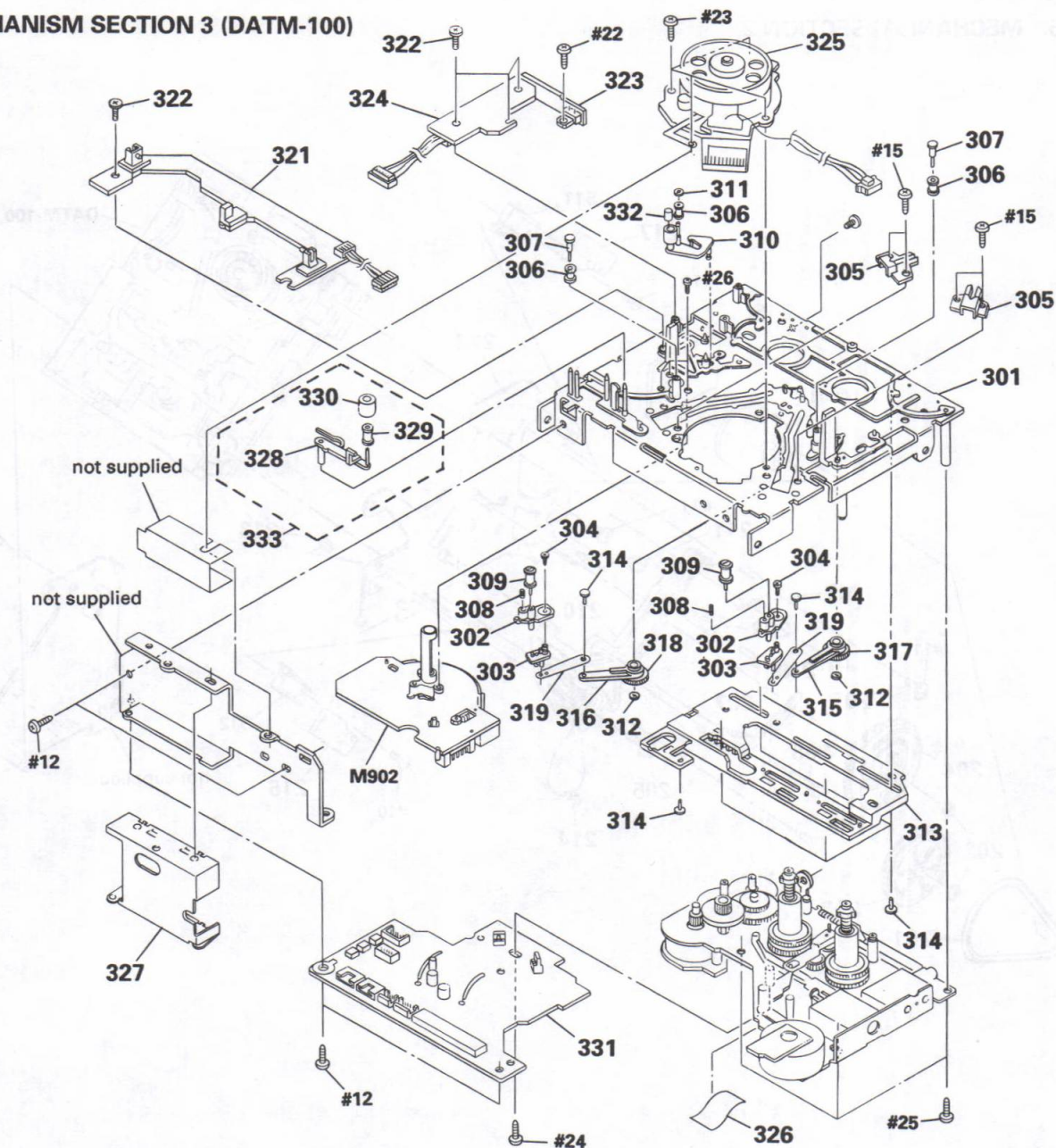

Ref. No.	Part No.	Description	Remarks	Ref. No.	Part No.	Description	Remarks
301	* 3-368-462-01	CHSSIS (OUTSERT), MECHANIAL		317	3-368-444-01	GEAR (LOAD-T)	
302	* 3-368-390-01	BASE (#1 GUIDE)		318	3-368-443-01	GEAR (LOAD-S)	
303	3-368-409-01	JOINT (#1 GUIDE)		319	3-368-415-01	SHAFT (LOAD LEVER JOINT)	
304	3-368-413-01	SCREW, +P (1) B1.4X2.5		321	* 1-639-305-11	TOP END SENSOR BOARD	
305	* 3-368-442-01	CATCHER		323	* 1-639-301-11	RGN SW BOARD	
306	3-368-399-01	GUIDE, ROLLER		324	* 1-639-306-11	CAM SLIDER BOARD	
307	3-368-428-01	SHAFT (ROLLER GUIDE)		325	8-848-567-01	DRUM ASSY DOU-03A	
308	3-368-436-01	SPRING (#1 GUIDE), COMPRESSION		326	9-911-835-XX	SPACER	
309	X-3337-643-1	GUIDE (RIC) ASSY, ROLLER		327	* A-2001-587-A	RF COMPLETE ASSY	
310	X-3363-025-1	PINCH (LEVER) ASSY		328	3-368-459-01	LEVER (CLEANER)	
311	3-315-384-31	WASHER, STOPPER		329	3-353-812-01	COLLAR (ROLLER)	
312	3-368-398-01	BUSHING		330	3-352-518-01	ROLLER (CLEANER)	
313	* A-2003-708-A	SLIDER ASSY, CAM		331	* A-2056-488-A	DRUM DRIVE BOARD, COMPLETE	
314	3-368-414-01	SHAFT (CAM SLIDER GUIDE)		332	3-337-626-01	CAP, PINCH ROLLER	
315	3-368-427-01	LEVER (LOAD-T)		333	X-3337-655-1	ROLLER (CLEANER) ASSY	
316	3-368-426-01	LEVER (LOAD-S)		M902	8-835-361-01	MOTOR, DC U-17B (CAPSTAN)	

5-7. MECHANISM SECTION 4 (DATM-100)

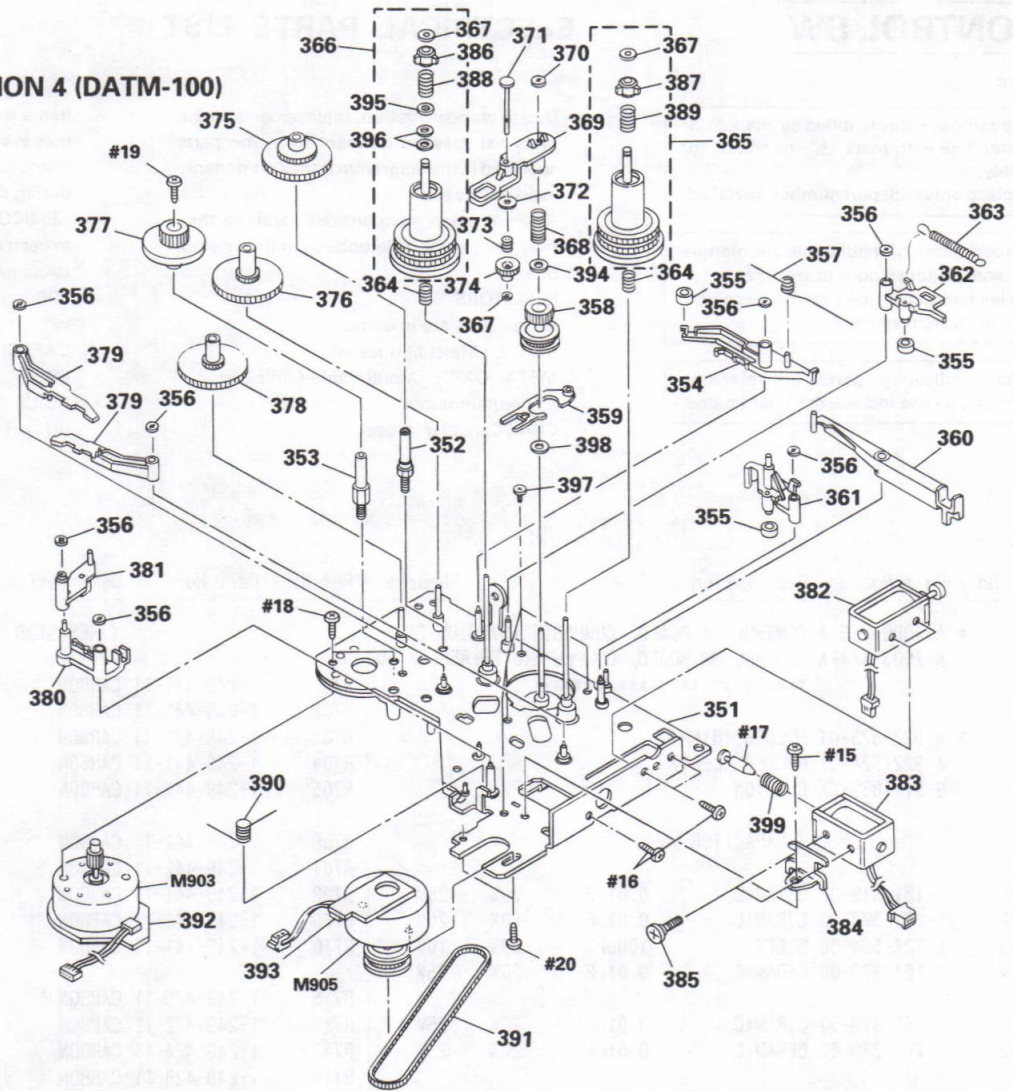

Ref. No.	Part No.	Description	Remarks	Ref. No.	Part No.	Description	Remarks
351	* A-2003-857-A	CHASSIS (REEL) ASSY		376	3-368-402-11	GEAR (CAM DRIVE A, B)	
352	* 3-368-420-01	SHAFT (CAM DRIVE GEAR C)		377	3-368-403-01	GEAR (CAM DRIVE D)	
353	* 3-368-419-01	SHAFT (CAM DRIVE GEAR D)		378	3-368-402-01	GEAR (CAM DRIVE A, B)	
354	* 3-368-455-01	LEVER (GEAR LOCK)		379	X-3363-024-1	LEVER (BT) ASSY	
355	3-368-418-01	TUBE (BREAK)		380	* 3-368-451-01	LEVER (BT SOLENOID)	
356	3-368-398-01	BUSHING		381	* 3-368-454-01	LEVER (BT SELECTION)	
357	3-368-430-01	SPRING (GEAR LOCK)		382	1-454-535-11	SOLENOID, PLUNGER (BRAKE)	
358	X-3363-022-1	GEAR (REEL DRIVE) ASSY		383	1-454-536-11	SOLENOID, PLUNGER (BT CONTROL)	
359	* 3-368-411-01	SLIDER (REEL LOCK)		384	* 3-368-416-01	BRACKET (B. T SOLENOID)	
360	* 3-368-453-01	LEVER (BRAKE SOLENOID)		385	3-368-423-01	SCREW (M2. 6), STEP	
361	* 3-368-447-01	LEVER (BRAKE S)		386	2-623-736-01	CLAW (C) (LEFT), REEL	
362	* 3-368-446-01	LEVER (BRAKE T)		387	2-623-752-01	CLAW (C) (RIGHT), REEL	
363	3-368-438-01	SPRING (BREAK), TENSION		388	3-370-481-01	SPRING (T), COMPRESSION	
364	3-368-432-01	SPRING (FF/REW), COMPRESSION		389	3-370-482-01	SPRING (S), COMPRESSION	
365	A-2003-709-A	TABLE (S) ASSY, REEL		390	3-368-431-01	SPRING (B. T SOLENOID)	
366	A-2003-710-A	TABLE (T) ASSY, REEL		391	3-368-417-01	BELT (170TN10-1.0T), TIMING	
367	3-578-224-00	WASHER		392	* 1-639-303-11	CAM MOTOR BOARD	
368	3-368-435-01	SPRING (FR LEVER), COMPRESSION		393	* 1-639-304-11	REEL MOTOR BOARD	
369	3-368-450-01	LEVER (F/R)		394	3-738-212-21	RETAINER, THRUST, REEL TABLE	
370	3-315-384-31	WASHER, STOPPER		396	3-701-443-21	WASHER, 5 DIA.	
371	3-368-429-01	SHAFT (NECK)		397	2-623-756-01	SCREW, (B1.7X3), TAPPING	
372	3-368-422-01	POLY-SLIDER(DIA. 4.5-DIA. 1.5)		398	3-701-436-01	WASHER, 1.6	
373	3-368-437-01	SPRING (GEAR NECK), COMPRESSION		399	3-370-480-01	SPRING (BT), COMPRESSION	
374	3-368-406-01	GEAR (NECK)		M903	X-3363-109-1	MOTOR (CAM) ASSY	
375	3-368-421-01	GEAR (CAM DRIVE C)		M905	X-3363-110-1	MOTOR (REEL) ASSY	

SECTION 6

CONTROL SW

ELECTRICAL PARTS LIST

NOTE:

The components identified by mark Δ or dotted line with mark Δ are critical for safety.
Replace only with part number specified.

Les composants identifiés par une marque Δ sont critiques pour la sécurité.
Ne les remplacer que par une pièce portant le numéro spécifié.

When indicating parts by reference number, please include the board name.

- Due to standardization, replacements in the parts list may be different from the parts specified in the diagrams or the components used on the set.
- -XX, -X mean standardized parts, so they may have some difference from the original one.
- RESISTORS
All resistors are in ohms
METAL : Metal-film resistor
METAL OXIDE : Metal Oxide-film resistor
F : nonflammable
- CND : Canadian model
- Items marked "*" are not stocked since they are seldom required for routine service. Some delay should be anticipated when ordering these items.
- SEMICONDUCTORS
In each case, u : μ , for example :
uA...: μ A..., uPA...: μ PA...,
uPB...: μ PB..., uPC...: μ PC...,
uPD...: μ PD...
- CAPACITORS
uF : μ F
- COILS
uH : μ H

Ref. No.	Part No.	Description	Remarks	Ref. No.	Part No.	Description	Remarks
* A-2006-555-A		CONTROL SW BOARD, COMPLETE (57ES:US, CND)				< RESISTOR >	
* A-2006-444-A		CONTROL SW BOARD, COMPLETE(57ES:AEP, E/750)					

* 4-922-523-01		HOLDER (RIGHT)		R701	1-249-441-11	CARBON	100K 5% 1/4W
* 4-922-524-01		HOLDER (LEFT)		R702	1-249-441-11	CARBON	100K 5% 1/4W
9-911-839-XX		CUSHION		R703	1-249-441-11	CARBON	100K 5% 1/4W
		< CAPACITOR >		R704	1-249-441-11	CARBON	100K 5% 1/4W
C701	1-161-379-00	CERAMIC	0.01uF 20% 25V	R705	1-249-441-11	CARBON	100K 5% 1/4W
C702	1-161-379-00	CERAMIC	0.01uF 20% 25V	R706	1-249-441-11	CARBON	100K 5% 1/4W
C703	1-124-584-00	ELECT	100uF 20% 10V	R707	1-249-441-11	CARBON	100K 5% 1/4W
C704	1-161-379-00	CERAMIC	0.01uF 20% 25V	R708	1-249-441-11	CARBON	100K 5% 1/4W
C705	1-161-379-00	CERAMIC	0.01uF 20% 25V	R709	1-249-441-11	CARBON	100K 5% 1/4W
C706	1-161-379-00	CERAMIC	0.01uF 20% 25V	R710	1-249-441-11	CARBON	100K 5% 1/4W
		< CONNECTOR >		R715	1-249-429-11	CARBON	10K 5% 1/4W
CN751	1-568-853-11	SOCKET, CONNECTOR 10P		R716	1-249-422-11	CARBON	2.7K 5% 1/4W
CN752	1-568-849-11	SOCKET, CONNECTOR 6P		R717	1-249-424-11	CARBON	3.9K 5% 1/4W
		< INDICATOR TUBE >		R718	1-249-428-11	CARBON	8.2K 5% 1/4W
FL701	1-519-672-11	INDICATOR TUBE, FLUORESCENT		R719	1-249-434-11	CARBON	27K 5% 1/4W
		< IC >		R720	1-249-429-11	CARBON	10K 5% 1/4W
IC701	8-752-818-86	IC CXP5058H-657Q		R721	1-249-422-11	CARBON	2.7K 5% 1/4W
IC702	8-759-995-09	IC MSM6338RS		R722	1-249-424-11	CARBON	3.9K 5% 1/4W
IC703	8-752-330-59	IC CXK1011P		R723	1-249-428-11	CARBON	8.2K 5% 1/4W
IC705	8-759-140-11	IC MC14011BCP		R724	1-249-434-11	CARBON	27K 5% 1/4W
		< TRANSISTOR >		R725	1-249-429-11	CARBON	10K 5% 1/4W
Q701	8-729-119-78	TRANSISTOR 2SC2785-HFE		R726	1-249-422-11	CARBON	2.7K 5% 1/4W
Q702	8-729-119-78	TRANSISTOR 2SC2785-HFE		R727	1-249-424-11	CARBON	3.9K 5% 1/4W
Q703	8-729-119-78	TRANSISTOR 2SC2785-HFE		R728	1-249-428-11	CARBON	8.2K 5% 1/4W
Q704	8-729-119-78	TRANSISTOR 2SC2785-HFE		R729	1-249-434-11	CARBON	27K 5% 1/4W
Q705	8-729-119-78	TRANSISTOR 2SC2785-HFE		R730	1-249-429-11	CARBON	10K 5% 1/4W
Q706	8-729-119-78	TRANSISTOR 2SC2785-HFE		R731	1-249-422-11	CARBON	2.7K 5% 1/4W
Q707	8-729-119-78	TRANSISTOR 2SC2785-HFE		R732	1-249-424-11	CARBON	3.9K 5% 1/4W
Q708	8-729-119-78	TRANSISTOR 2SC2785-HFE		R733	1-249-429-11	CARBON	10K 5% 1/4W
Q709	8-729-119-78	TRANSISTOR 2SC2785-HFE		R734	1-249-422-11	CARBON	2.7K 5% 1/4W
Q710	8-729-119-78	TRANSISTOR 2SC2785-HFE		R735	1-249-424-11	CARBON	3.9K 5% 1/4W
				R736	1-249-429-11	CARBON	10K 5% 1/4W
				R737	1-249-422-11	CARBON	2.7K 5% 1/4W
				R738	1-249-424-11	CARBON	3.9K 5% 1/4W
				R739	1-249-428-11	CARBON	8.2K 5% 1/4W
				R740	1-249-434-11	CARBON	27K 5% 1/4W
				R741	1-249-429-11	CARBON	10K 5% 1/4W
				R742	1-249-422-11	CARBON	2.7K 5% 1/4W

CONTROL SW**BALANCE VOL****CAM MOTOR****CAM SLIDER**

Ref. No.	Part No.	Description	Remarks	Ref. No.	Part No.	Description	Remarks
R743	1-249-424-11	CARBON	3. 9K 5% 1/4W	S732	1-554-937-11	SWITCH, KEY BOARD (STOP □)	
R744	1-249-428-11	CARBON	8. 2K 5% 1/4W	S733	1-554-937-11	SWITCH, KEY BOARD (PLAY ▷)	
R745	1-249-434-11	CARBON	27K 5% 1/4W	S734	1-554-937-11	SWITCH, KEY BOARD (PREV ◀◀)	
R746	1-249-429-11	CARBON	10K 5% 1/4W	S735	1-554-937-11	SWITCH, KEY BOARD (NEXT ▶▶)	
R747	1-249-422-11	CARBON	2. 7K 5% 1/4W	S736	1-554-937-11	SWITCH, KEY BOARD (END ID WRITE)	
R748	1-249-424-11	CARBON	3. 9K 5% 1/4W	S737	1-554-937-11	SWITCH, KEY BOARD (END ID ERASE)	
R749	1-249-428-11	CARBON	8. 2K 5% 1/4W	S738	1-554-937-11	SWITCH, KEY BOARD (CLEAR)	
R750	1-249-434-11	CARBON	27K 5% 1/4W	S739	1-554-937-11	SWITCH, KEY BOARD (0 -)	
R751	1-249-437-11	CARBON	47K 5% 1/4W	S740	1-554-937-11	SWITCH, KEY BOARD (MUSIC SCAN +)	
R752	1-249-437-11	CARBON	47K 5% 1/4W			< CRYSTAL >	
R753	1-249-437-11	CARBON	47K 5% 1/4W	X701	1-577-359-21	VIBRATOR, CERAMIC (4.19MHz)	
R754	1-249-437-11	CARBON	47K 5% 1/4W			*****	
R755	1-249-437-11	CARBON	47K 5% 1/4W			* 1-639-326-11 BALANCE VOL BOARD	
R756	1-249-437-11	CARBON	47K 5% 1/4W			*****	
R757	1-249-437-11	CARBON	47K 5% 1/4W			< CONNECTOR >	
R758	1-249-437-11	CARBON	47K 5% 1/4W	CN102	* 1-564-507-11	PLUG, CONNECTOR 4P	
R759	1-249-437-11	CARBON	47K 5% 1/4W			< RESISTOR >	
R760	1-249-437-11	CARBON	47K 5% 1/4W	R101	1-259-462-11	CARBON 27K 5% 1/6W	
R761	1-249-437-11	CARBON	47K 5% 1/4W	R201	1-259-462-11	CARBON 27K 5% 1/6W	
R762	1-249-437-11	CARBON	47K 5% 1/4W			< VARIABLE RESISTOR >	
R763	1-249-437-11	CARBON	47K 5% 1/4W	RV101	1-238-687-11	RES, VAR, CARBON 50K/50K (BALANCE)	
R764	1-249-437-11	CARBON	47K 5% 1/4W			*****	
		< SWITCH >				* 1-639-303-11 CAM MOTOR BOARD	
S704	1-554-937-11	SWITCH, KEY BOARD (CLOCK SET)				*****	
S705	1-554-937-11	SWITCH, KEY BOARD (SKIP ID WRITE)				< CAPACITOR >	
S706	1-554-937-11	SWITCH, KEY BOARD (SKIP ID ERASE)		C06	1-163-077-00	CERAMIC CHIP 0.1uF 10% 25V	
S707	1-554-937-11	SWITCH, KEY BOARD (7)				*****	
S708	1-554-937-11	SWITCH, KEY BOARD (8)				* 1-639-306-11 CAM SLIDER BOARD	
S709	1-554-937-11	SWITCH, KEY BOARD (9)				*****	
S710	1-554-937-11	SWITCH, KEY BOARD (START ID WRITE)				< CHIP JUMPER >	
S711	1-554-937-11	SWITCH, KEY BOARD (START ID ERASE)		JW04	1-216-296-00	METAL CHIP 0 5% 1/8W	
S712	1-554-937-11	SWITCH, KEY BOARD (4)		JW05	1-216-296-00	METAL CHIP 0 5% 1/8W	
S713	1-554-937-11	SWITCH, KEY BOARD (5)				< SWITCH >	
S714	1-554-937-11	SWITCH, KEY BOARD (6)		SW1	1-570-953-11	SWITCH, PUSH (1 KEY) (STOP DET)	
S715	1-554-937-11	SWITCH, KEY BOARD (START ID AUTO)		SW2	1-570-953-11	SWITCH, PUSH (1 KEY) (FWD DET)	
S716	1-554-937-11	SWITCH, KEY BOARD (START ID RENUMBER)				*****	
S717	1-554-937-11	SWITCH, KEY BOARD (1)					
S718	1-554-937-11	SWITCH, KEY BOARD (2)					
S719	1-554-937-11	SWITCH, KEY BOARD (3)					
S720	1-554-937-11	SWITCH, KEY BOARD (RECORDED)					
S721	1-554-937-11	SWITCH, KEY BOARD (PRESENT)					
S722	1-554-937-11	SWITCH, KEY BOARD (FADER)					
S723	1-554-937-11	SWITCH, KEY BOARD (MARGIN RESET)					
S724	1-554-937-11	SWITCH, KEY BOARD (COUNTER RESET)					
S725	1-554-937-11	SWITCH, KEY BOARD (COUNTER MODE)					
S726	1-554-937-11	SWITCH, KEY BOARD (REW ◀◀)					
S727	1-554-937-11	SWITCH, KEY BOARD (FF ▶▶)					
S728	1-554-937-11	SWITCH, KEY BOARD (REC ○)					
S729	1-554-937-11	SWITCH, KEY BOARD (PAUSE □□)					
S730	1-554-937-11	SWITCH, KEY BOARD (REC MUTE ○)					
S731	1-554-937-11	SWITCH, KEY BOARD (O/C ⊞)					

When indicating parts by reference number, please include the board name.

CONTROL (S)

DRUM DRIVE

Ref. No.	Part No.	Description	Remarks
* 1-639-330-11 CONTROL (S) BOARD (57ES:US, CND)			

< CAPACITOR >			
C801	1-136-165-00	FILM 0.1uF 5% 50V	
C802	1-136-165-00	FILM 0.1uF 5% 50V	
< CONNECTOR >			
CN971	* 1-564-497-11	PIN, CONNECTOR 4P	
CN972	1-558-350-21	CORD (WITH CONNECTOR)	
< DIODE >			
D801	8-719-107-94	DIODE 1SS202-1	
D802	8-719-107-94	DIODE 1SS202-1	
< RESISTOR >			
R801	1-249-393-11	CARBON 10 5% 1/4W	
R802	1-249-429-11	CARBON 10K 5% 1/4W	
R803	1-249-429-11	CARBON 10K 5% 1/4W	
R804	1-249-405-11	CARBON 100 5% 1/4W	
R805	1-249-429-11	CARBON 10K 5% 1/4W	
R806	1-249-429-11	CARBON 10K 5% 1/4W	

* A-2056-488-A DRUM DRIVE BOARD, COMPLETE			

* 3-343-491-01 HOLDER (S SENSOR B)			
4-870-539-00 PLATE, GROUND			
< CAPACITOR >			
C01	1-124-584-00	ELECT 100uF 20% 10V	
C02	1-126-157-11	ELECT 10uF 20% 16V	
C03	1-124-257-00	ELECT 2.2uF 20% 50V	
C04	1-164-161-11	CERAMIC CHIP 0.0022uF 10% 100V	
C05	1-164-161-11	CERAMIC CHIP 0.0022uF 10% 100V	
C08	1-163-001-11	CERAMIC CHIP 220PF 10% 50V	
C21	1-163-001-11	CERAMIC CHIP 220PF 10% 50V	
C31	1-163-001-11	CERAMIC CHIP 220PF 10% 50V	
< CONNECTOR >			
CN01	* 1-564-704-11	PIN, CONNECTOR (SMALL TYPE) 2P	
CN02	* 1-564-704-11	PIN, CONNECTOR (SMALL TYPE) 2P	
CN03	* 1-564-338-00	PIN, CONNECTOR 4P	
CN04	* 1-564-336-00	PIN, CONNECTOR 2P	
CN05	* 1-564-336-61	PIN, CONNECTOR 2P	
CN06	* 1-564-339-00	PIN, CONNECTOR 5P	
CN07	1-564-721-11	PIN, CONNECTOR (SMALL TYPE) 5P	
CN08	* 1-568-872-11	SOCKET, CONNECTOR 30P	
CN09	* 1-564-706-11	PIN, CONNECTOR (SMALL TYPE) 4P	
CN10	* 1-564-719-11	PIN, CONNECTOR (SMALL TYPE) 3P	
< IC >			
IC01	8-759-107-68	IC CX20115A	
IC02	8-759-502-80	IC LM358M-FL63	
IC03	8-759-502-80	IC LM358M-FL63	

Ref. No.	Part No.	Description	Remarks
< CHIP JUMPER >			
JW06	1-216-296-00	METAL CHIP 0 5% 1/8W	
JW07	1-216-296-00	METAL CHIP 0 5% 1/8W	
JW08	1-216-296-00	METAL CHIP 0 5% 1/8W	
JW09	1-216-296-00	METAL CHIP 0 5% 1/8W	
JW10	1-216-296-00	METAL CHIP 0 5% 1/8W	
JW11	1-216-296-00	METAL CHIP 0 5% 1/8W	
JW12	1-216-296-00	METAL CHIP 0 5% 1/8W	
JW13	1-216-296-00	METAL CHIP 0 5% 1/8W	
JW14	1-216-296-00	METAL CHIP 0 5% 1/8W	
JW15	1-216-296-00	METAL CHIP 0 5% 1/8W	
JW16	1-216-296-00	METAL CHIP 0 5% 1/8W	
JW17	1-216-296-00	METAL CHIP 0 5% 1/8W	
JW18	1-216-296-00	METAL CHIP 0 5% 1/8W	
JW19	1-216-296-00	METAL CHIP 0 5% 1/8W	
JW20	1-216-296-00	METAL CHIP 0 5% 1/8W	
JW21	1-216-296-00	METAL CHIP 0 5% 1/8W	
JW22	1-216-296-00	METAL CHIP 0 5% 1/8W	
JW23	1-216-296-00	METAL CHIP 0 5% 1/8W	
JW24	1-216-296-00	METAL CHIP 0 5% 1/8W	
JW25	1-216-296-00	METAL CHIP 0 5% 1/8W	
JW26	1-216-296-00	METAL CHIP 0 5% 1/8W	
JW27	1-216-296-00	METAL CHIP 0 5% 1/8W	
JW28	1-216-296-00	METAL CHIP 0 5% 1/8W	
JW29	1-216-296-00	METAL CHIP 0 5% 1/8W	
JW30	1-216-296-00	METAL CHIP 0 5% 1/8W	
< PHOTO INTERRUPTER >			
PH01	8-719-939-23	GP2S09-C	
PH02	8-719-939-23	GP2S09-C	
< TRANSISTOR >			
Q01	8-729-100-66	TRANSISTOR 2SC1623	
Q02	8-729-101-07	TRANSISTOR 2SB798-DL	
< RESISTOR >			
R01	1-216-061-00	METAL CHIP 3.3K 5% 1/10W	
R02	1-216-075-00	METAL CHIP 12K 5% 1/10W	
R03	1-216-029-00	METAL CHIP 150 5% 1/10W	
R04	1-216-059-00	METAL CHIP 2.7K 5% 1/10W	
R05	1-216-057-00	METAL CHIP 2.2K 5% 1/10W	
R06	1-216-085-00	METAL CHIP 33K 5% 1/10W	
R07	1-216-025-00	METAL CHIP 100 5% 1/10W	
R08	1-216-049-00	METAL CHIP 1K 5% 1/10W	
R09	1-216-073-00	METAL CHIP 10K 5% 1/10W	
R10	1-216-073-00	METAL CHIP 10K 5% 1/10W	
R11	1-216-073-00	METAL CHIP 10K 5% 1/10W	
R12	1-216-089-00	METAL CHIP 47K 5% 1/10W	
R13	1-216-073-00	METAL CHIP 10K 5% 1/10W	
R14	1-216-037-00	METAL CHIP 330 5% 1/10W	
R21	1-216-073-00	METAL CHIP 10K 5% 1/10W	
R22	1-216-081-00	METAL CHIP 22K 5% 1/10W	

When indicating parts by reference number, please include the board name.

DRUM DRIVE

HEADPHONE

INPUT SW

MAIN

Ref. No.	Part No.	Description	Remarks	Ref. No.	Part No.	Description	Remarks
R23	1-216-077-00	METAL CHIP	15K 5% 1/10W				
R24	1-216-067-00	METAL CHIP	5.6K 5% 1/10W				
R25	1-216-103-00	METAL CHIP	180K 5% 1/10W				
R26	1-216-065-00	METAL CHIP	4.7K 5% 1/10W				
R31	1-216-073-00	METAL CHIP	10K 5% 1/10W				
R32	1-216-081-00	METAL CHIP	22K 5% 1/10W				
R35	1-216-103-00	METAL CHIP	180K 5% 1/10W				
R36	1-216-065-00	METAL CHIP	4.7K 5% 1/10W				

	* 1-639-327-11	HEADPHONE BOARD					

		< CAPACITOR >					
C180	1-162-290-31	CERAMIC	470PF 10% 50V				
C181	1-126-059-11	ELECT	10uF 20% 63V				
C280	1-162-290-31	CERAMIC	470PF 10% 50V				
C281	1-126-059-11	ELECT	10uF 20% 63V				
C451	1-126-024-11	ELECT	220uF 20% 25V				
C452	1-126-024-11	ELECT	220uF 20% 25V				
		< CONNECTOR >					
CNP701	* 1-566-910-11	HOUSING, CONNECTOR 3P					
		< DIODE >					
D401	8-719-200-82	DIODE 11ES2					
D402	8-719-200-82	DIODE 11ES2					
		< IC >					
IC401	8-759-981-98	IC RC4560DD					
		< JACK >					
J161	1-565-327-11	JACK, LARGE TYPE 1P					
		< RESISTOR >					
R128	1-259-468-11	CARBON	47K 5% 1/6W				
R129	1-259-444-11	CARBON	4.7K 5% 1/6W				
R130	1-259-468-11	CARBON	47K 5% 1/6W				
R131	1-259-412-11	CARBON	220 5% 1/6W				
R228	1-259-468-11	CARBON	47K 5% 1/6W				
R229	1-259-444-11	CARBON	4.7K 5% 1/6W				
R230	1-259-468-11	CARBON	47K 5% 1/6W				
R231	1-259-412-11	CARBON	220 5% 1/6W				
R460	△ 1-212-857-00	FUSIBLE	10 5% 1/4W F				
R461	△ 1-212-857-00	FUSIBLE	10 5% 1/4W F				
R799	1-249-437-11	CARBON	47K 5% 1/4W				
		< VARIABLE RESISTOR >					
RV103	1-241-537-11	RES, VAR, CARBON 20K/20K (PHONE LEVEL)					

	* 1-639-328-11	INPUT SW BOARD					

		< CONNECTOR >					
CN772	* 1-564-336-00	PIN, CONNECTOR 2P					
CNP702	* 1-566-910-11	HOUSING, CONNECTOR 3P					
		< RESISTOR >					
R713	1-249-428-11	CARBON	8.2K 5% 1/4W				
R714	1-249-434-11	CARBON	27K 5% 1/4W				
		< SWITCH >					
S702	1-572-758-11	SWITCH, ROTARY (INPUT)					

	* A-2006-572-A	MAIN BOARD, COMPLETE (57ES:US, CND, E)					
	* A-2006-614-A	MAIN BOARD, COMPLETE (57ES:AEP)					
	* A-2006-681-A	MAIN BOARD, COMPLETE (750:US, CND)					
	* A-2006-682-A	MAIN BOARD, COMPLETE (750:UK)					

		< CAPACITOR >					
C102	1-126-233-11	ELECT	22uF 20% 50V				
C103	1-130-955-00	FILM	0.01uF 5% 100V				
C110	1-136-439-11	FILM	330PF 5% 630V				
C111	1-136-439-11	FILM	330PF 5% 630V				
C112	1-136-437-11	FILM	220PF 5% 630V				
C113	1-136-437-11	FILM	220PF 5% 630V				
C114	1-136-433-11	FILM	100PF 5% 630V				
C115	1-136-433-11	FILM	100PF 5% 630V				
C116	1-136-230-00	FILM	0.0022uF 5% 100V				
C117	1-136-228-11	FILM	0.0012uF 5% 100V				
C118	1-136-233-11	FILM	0.0047uF 5% 100V				
C120	1-124-122-11	ELECT	100uF 20% 50V				
C202	1-126-233-11	ELECT	22uF 20% 50V				
C203	1-130-955-00	FILM	0.01uF 5% 100V				
C210	1-136-439-11	FILM	330PF 5% 630V				
C211	1-136-439-11	FILM	330PF 5% 630V				
C212	1-136-437-11	FILM	220PF 5% 630V				
C213	1-136-437-11	FILM	220PF 5% 630V				
C214	1-136-433-11	FILM	100PF 5% 630V				
C215	1-136-433-11	FILM	100PF 5% 630V				
C216	1-136-230-00	FILM	0.0022uF 5% 100V				
C217	1-136-228-11	FILM	0.0012uF 5% 100V				
C218	1-136-233-11	FILM	0.0047uF 5% 100V				
C220	1-124-122-11	ELECT	100uF 20% 50V				
C300	1-162-294-31	CERAMIC	0.001uF 10% 50V				
C301	1-130-834-00	FILM	1uF 10% 63V				
C302	1-164-159-11	CERAMIC	0.1uF 50V				
C303	1-162-211-31	CERAMIC	33PF 5% 50V				
C304	1-126-059-11	ELECT	10uF 20% 63V				
C305	1-136-153-00	FILM	0.01uF 5% 50V				

The components identified by mark Δ or dotted line with mark Δ are critical for safety.
Replace only with part number specified.

Les composants identifiés par une marque Δ sont critiques pour la sécurité.
Ne les remplacer que par une pièce portant le numéro spécifié.

When indicating parts by reference number, please include the board name.

MAIN

Ref. No.	Part No.	Description	Remarks	Ref. No.	Part No.	Description	Remarks
D321	8-719-107-94	DIODE 1SS202-1		L302	1-410-498-11	INDUCTOR 1.2uH	
D322	8-719-911-06	DIODE 1SS106		L303	1-410-509-11	INDUCTOR 10uH	
D323	8-719-107-94	DIODE 1SS202-1		L305	1-410-509-11	INDUCTOR 10uH	
D324	8-719-911-06	DIODE 1SS106		L306	1-410-509-11	INDUCTOR 10uH	
D403	8-719-107-94	DIODE 1SS202-1		L310	1-410-953-11	INDUCTOR, SMALL TYPE (57ES)	
D404	8-719-210-21	DIODE 11EQS04				(TRANSISTOR)	
		(IC)		Q301	8-729-927-11	TRANSISTOR 2SA1585S-QR	
IC301	8-759-917-18	IC SN74HCU04AN		Q311	8-729-900-80	TRANSISTOR DTC114ES	
IC302	8-759-232-49	IC TC74HC132AP		Q312	8-729-107-85	TRANSISTOR 2SC3623A-K	
IC303	8-759-917-18	IC SN74HCU04AN		Q313	8-729-900-61	TRANSISTOR DTA114ES	
IC304	8-759-135-80	IC uPC358C		Q318	8-729-900-80	TRANSISTOR DTC114ES	
IC305	8-759-926-17	IC SN74HC153ANS		Q319	8-729-900-80	TRANSISTOR DTC114ES	
IC306	8-759-947-57	IC CXD1136Q		Q320	8-729-927-11	TRANSISTOR 2SA1585S-QR	
IC307	8-752-339-43	IC CXD2601AQ		Q321	8-729-927-12	TRANSISTOR 2SC4115S-QR	
IC308	8-759-906-24	IC SN74LS624N		Q343	8-729-920-68	TRANSISTOR 2SA933S-QR	
IC309	8-759-925-90	IC SN74HC74ANS		Q399	8-729-900-80	TRANSISTOR DTC114ES	
IC310	8-752-330-68	IC CKX58257M-12L		Q432	8-729-900-80	TRANSISTOR DTC114ES	
IC311	8-752-818-91	IC CXP80524-025Q		Q433	8-729-107-85	TRANSISTOR 2SC3623A-K	
IC312	8-752-832-33	IC CXP80524-040Q		Q434	8-729-107-85	TRANSISTOR 2SC3623A-K	
IC319	8-759-633-65	IC M54641L		Q435	8-729-900-61	TRANSISTOR DTA114ES	
IC320	8-759-633-65	IC M54641L		Q436	8-729-900-80	TRANSISTOR DTC114ES	
IC321	8-759-971-12	IC PST529E		Q437	8-729-900-61	TRANSISTOR DTA114ES	
IC322	8-759-231-53	IC TA7805S		Q438	8-729-900-80	TRANSISTOR DTC114ES	
IC330	8-759-984-34	IC RP5C62		Q439	8-729-900-80	TRANSISTOR DTC114ES	
IC331	8-749-921-11	IC GP1F32R		Q440	8-729-119-78	TRANSISTOR 2SC2785-HFE	
IC332	8-749-921-12	IC GP1F32T				(RESISTOR)	
IC333	8-759-917-18	IC SN74HCU04AN		R102	1-247-903-00	CARBON 1M 5% 1/4W	
IC354	8-759-900-72	IC NE5532P		R103	1-249-417-11	CARBON 1K 5% 1/4W	
IC355	8-759-900-72	IC NE5532P		R104	1-249-433-11	CARBON 22K 5% 1/4W	
IC356	8-759-945-58	IC RC4558P		R105	1-249-435-11	CARBON 33K 5% 1/4W	
IC357	8-759-231-53	IC TA7805S		R106	1-249-403-11	CARBON 68 5% 1/4W	
IC358	8-759-245-79	IC TA7905S		R107	1-247-854-11	CARBON 9.1K 5% 1/4W	
IC359	8-759-504-36	IC CS5339-KP		R108	1-247-854-11	CARBON 9.1K 5% 1/4W	
IC360	8-759-972-47	IC LF412CN		R109	1-247-854-11	CARBON 9.1K 5% 1/4W	
IC361	8-759-602-83	IC M5238P		R110	1-247-854-11	CARBON 9.1K 5% 1/4W	
IC362	8-752-344-10	IC CXD2561M		R111	1-249-425-11	CARBON 4.7K 5% 1/4W	
IC363	8-752-342-65	IC CXD2560M		R112	1-249-425-11	CARBON 4.7K 5% 1/4W	
IC374	8-759-634-55	IC M5F7805L-720		R113	1-249-425-11	CARBON 4.7K 5% 1/4W	
IC375	8-759-900-72	IC NE5532P		R114	1-249-425-11	CARBON 4.7K 5% 1/4W	
IC376	8-759-900-72	IC NE5532P		R115	1-249-430-11	CARBON 12K 5% 1/4W	
IC431	8-759-925-78	IC SN74HC10ANS		R116	1-249-430-11	CARBON 12K 5% 1/4W	
IC432	8-759-995-76	IC PST529C		R117	1-249-426-11	CARBON 5.6K 5% 1/4W	
		(JACK)		R118	1-249-426-11	CARBON 5.6K 5% 1/4W	
J101	1-568-751-61	JACK, PIN (2P SHIELD TYPE)		R119	1-249-426-11	CARBON 5.6K 5% 1/4W	
J102	1-568-751-61	JACK, PIN (2P SHIELD TYPE)		R120	1-249-426-11	CARBON 5.6K 5% 1/4W	
J181	1-565-406-41	JACK, PIN 1P (57ES)		R121	1-249-405-11	CARBON 100 5% 1/4W	
J191	1-568-750-21	JACK, PIN (1P SHIELD TYPE)		R122	1-249-419-11	CARBON 1.5K 5% 1/4W	
		(COIL)		R123	1-249-419-11	CARBON 1.5K 5% 1/4W	
L301	1-410-509-11	INDUCTOR 10uH		R124	1-249-441-11	CARBON 100K 5% 1/4W	
				R125	1-249-409-11	CARBON 220 5% 1/4W	
				R126	1-249-429-11	CARBON 10K 5% 1/4W	

When indicating parts by reference number, please include the board name.

MAIN

Ref. No.	Part No.	Description				Remarks	Ref. No.	Part No.	Description				Remarks
R127	1-249-405-11	CARBON	100	5%	1/4W		R325	1-249-425-11	CARBON	4.7K	5%	1/4W	
R180	1-249-397-11	CARBON	22	5%	1/4W		R326	1-249-409-11	CARBON	220	5%	1/4W	
R202	1-247-903-00	CARBON	1M	5%	1/4W		R327	1-249-425-11	CARBON	4.7K	5%	1/4W	
R203	1-249-417-11	CARBON	1K	5%	1/4W		R328	1-249-417-11	CARBON	1K	5%	1/4W	
R204	1-249-433-11	CARBON	22K	5%	1/4W		R329	1-249-413-11	CARBON	470	5%	1/4W	
R205	1-249-435-11	CARBON	33K	5%	1/4W		R330	1-249-417-11	CARBON	1K	5%	1/4W	
R206	1-249-403-11	CARBON	68	5%	1/4W		R331	1-249-429-11	CARBON	10K	5%	1/4W	
R207	1-247-854-11	CARBON	9.1K	5%	1/4W		R332	1-249-429-11	CARBON	10K	5%	1/4W	
R208	1-247-854-11	CARBON	9.1K	5%	1/4W		R333	1-249-433-11	CARBON	22K	5%	1/4W	
R209	1-247-854-11	CARBON	9.1K	5%	1/4W		R334	1-249-425-11	CARBON	4.7K	5%	1/4W	
R210	1-247-854-11	CARBON	9.1K	5%	1/4W		R335	1-249-425-11	CARBON	4.7K	5%	1/4W	
R211	1-249-425-11	CARBON	4.7K	5%	1/4W		R336	1-249-425-11	CARBON	4.7K	5%	1/4W	
R212	1-249-425-11	CARBON	4.7K	5%	1/4W		R346	1-249-441-11	CARBON	100K	5%	1/4W	
R213	1-249-425-11	CARBON	4.7K	5%	1/4W		R347	1-249-441-11	CARBON	100K	5%	1/4W	
R214	1-249-425-11	CARBON	4.7K	5%	1/4W		R348	1-249-441-11	CARBON	100K	5%	1/4W	
R215	1-249-430-11	CARBON	12K	5%	1/4W		R349	1-249-441-11	CARBON	100K	5%	1/4W	
R216	1-249-430-11	CARBON	12K	5%	1/4W		R350	1-249-425-11	CARBON	4.7K	5%	1/4W	
R217	1-249-426-11	CARBON	5.6K	5%	1/4W		R351	1-249-425-11	CARBON	4.7K	5%	1/4W	
R218	1-249-426-11	CARBON	5.6K	5%	1/4W		R353	1-249-441-11	CARBON	100K	5%	1/4W	
R219	1-249-426-11	CARBON	5.6K	5%	1/4W		R365	1-249-425-11	CARBON	4.7K	5%	1/4W	
R220	1-249-426-11	CARBON	5.6K	5%	1/4W		R378	1-249-417-11	CARBON	1K	5%	1/4W	
R221	1-249-405-11	CARBON	100	5%	1/4W		R379	1-249-401-11	CARBON	47	5%	1/4W	
R222	1-249-419-11	CARBON	1.5K	5%	1/4W		R380	1-249-411-11	CARBON	330	5%	1/4W	
R223	1-249-419-11	CARBON	1.5K	5%	1/4W		R381	△ 1-215-881-11	METAL OXIDE	15	5%	2W	F
R224	1-249-441-11	CARBON	100K	5%	1/4W		R386	1-249-405-11	CARBON	100	5%	1/4W	
R225	1-249-409-11	CARBON	220	5%	1/4W		R387	1-249-405-11	CARBON	100	5%	1/4W	
R226	1-249-429-11	CARBON	10K	5%	1/4W		R388	1-249-423-11	CARBON	3.3K	5%	1/4W	
R227	1-249-405-11	CARBON	100	5%	1/4W		R389	1-249-423-11	CARBON	3.3K	5%	1/4W	
R280	1-249-397-11	CARBON	22	5%	1/4W		R390	1-249-423-11	CARBON	3.3K	5%	1/4W	
R301	1-247-804-11	CARBON	75	5%	1/4W		R391	1-249-423-11	CARBON	3.3K	5%	1/4W	
R302	1-249-437-11	CARBON	47K	5%	1/4W		R392	1-249-430-11	CARBON	12K	5%	1/4W	
R303	1-249-421-11	CARBON	2.2K	5%	1/4W		R393	1-247-864-11	CARBON	24K	5%	1/4W	
R304	1-249-441-11	CARBON	100K	5%	1/4W		R394	1-249-429-11	CARBON	10K	5%	1/4W	
R305	1-249-421-11	CARBON	2.2K	5%	1/4W		R395	1-249-425-11	CARBON	4.7K	5%	1/4W	
R306	1-249-417-11	CARBON	1K	5%	1/4W		R396	1-249-441-11	CARBON	100K	5%	1/4W	
R307	1-249-417-11	CARBON	1K	5%	1/4W		R397	1-249-441-11	CARBON	100K	5%	1/4W	
R308	1-249-425-11	CARBON	4.7K	5%	1/4W		R398	1-249-441-11	CARBON	100K	5%	1/4W	
R309	1-249-421-11	CARBON	2.2K	5%	1/4W		R399	1-249-441-11	CARBON	100K	5%	1/4W	
R310	1-249-421-11	CARBON	100K	5%	1/4W		R400	1-249-441-11	CARBON	100K	5%	1/4W	
R311	1-249-429-11	CARBON	10K	5%	1/4W		R401	1-249-441-11	CARBON	100K	5%	1/4W	
R312	1-249-421-11	CARBON	2.2K	5%	1/4W		R402	1-249-441-11	CARBON	100K	5%	1/4W	
R313	1-249-421-11	CARBON	2.2K	5%	1/4W		R403	1-249-441-11	CARBON	100K	5%	1/4W	
R314	1-249-435-11	CARBON	33K	5%	1/4W		R404	1-249-441-11	CARBON	100K	5%	1/4W	
R315	1-249-429-11	CARBON	10K	5%	1/4W		R405	1-249-441-11	CARBON	100K	5%	1/4W	
R316	1-247-804-11	CARBON	75	5%	1/4W	(57ES)	R406	1-249-429-11	CARBON	10K	5%	1/4W	
R317	1-249-405-11	CARBON	100	5%	1/4W	(57ES)	R407	1-249-429-11	CARBON	10K	5%	1/4W	
R318	1-249-409-11	CARBON	220	5%	1/4W		R408	1-249-429-11	CARBON	10K	5%	1/4W	
R319	1-249-409-11	CARBON	220	5%	1/4W		R409	1-249-425-11	CARBON	4.7K	5%	1/4W	
R320	1-247-804-11	CARBON	75	5%	1/4W		R410	1-249-425-11	CARBON	4.7K	5%	1/4W	
R321	1-249-405-11	CARBON	100	5%	1/4W		R411	1-249-417-11	CARBON	1K	5%	1/4W	
R322	1-249-429-11	CARBON	10K	5%	1/4W		R412	1-249-441-11	CARBON	100K	5%	1/4W	
R323	1-249-433-11	CARBON	22K	5%	1/4W		R413	1-249-437-11	CARBON	47K	5%	1/4W	
R324	1-249-433-11	CARBON	22K	5%	1/4W		R414	1-249-413-11	CARBON	470	5%	1/4W	

The components identified by mark △ or dotted line with mark △ are critical for safety.
Replace only with part number specified.

Les composants identifiés par une marque △ sont critiques pour la sécurité.
Ne les remplacer que par une pièce portant le numéro spécifié.

When indicating parts by reference number, please include the board name.

MAIN **MOTOR** **PLL**

Ref. No.	Part No.	Description	Remarks	Ref. No.	Part No.	Description	Remarks
R415	1-249-437-11	CARBON	47K 5% 1/4W		* 1-639-646-11	MOTOR BOARD	
R416	1-249-437-11	CARBON	47K 5% 1/4W			*****	
R417	1-249-437-11	CARBON	47K 5% 1/4W			< CAPACITOR >	
R418	1-249-413-11	CARBON	470 5% 1/4W				
R419	1-249-413-11	CARBON	470 5% 1/4W				
R420	1-249-413-11	CARBON	470 5% 1/4W		C06	1-162-851-11 CERAMIC 0.1MF	16V
R421	1-249-413-11	CARBON	470 5% 1/4W			< CONNECTOR >	
R422	1-249-413-11	CARBON	470 5% 1/4W				
R424	1-249-411-11	CARBON	330 5% 1/4W		CN01	* 1-564-336-00 PIN, CONNECTOR 2P	
R425	1-249-411-11	CARBON	330 5% 1/4W		CN02	* 1-564-336-61 PIN, CONNECTOR 2P	
					CN03	* 1-564-498-11 PIN, CONNECTOR 5P	
R430	1-249-399-11	CARBON	33 5% 1/4W			*****	
R431	1-249-399-11	CARBON	33 5% 1/4W				
R432	1-249-393-11	CARBON	10 5% 1/4W				
R433	1-216-349-00	CARBON	1 5% 1/2W				
R434	1-249-411-11	CARBON	330 5% 1/4W			* 1-639-920-11 PLL BOARD	

R435	1-249-409-11	CARBON	220 5% 1/4W				
R436	1-249-409-11	CARBON	220 5% 1/4W			1-543-563-11 FERRITE BOARD, MULTI HOLE	
R437	1-249-409-11	CARBON	220 5% 1/4W			< CAPACITOR >	
R438	1-249-409-11	CARBON	220 5% 1/4W				
R439	1-249-437-11	CARBON	47K 5% 1/4W				
R440	1-249-441-11	CARBON	100K 5% 1/4W		C501	1-136-153-00 FILM 0.01uF	5% 50V
R441	1-249-441-11	CARBON	100K 5% 1/4W		C502	1-162-284-31 CERAMIC 150PF	10% 50V
R442	1-249-441-11	CARBON	100K 5% 1/4W		C503	1-162-199-31 CERAMIC 10PF	5% 50V
R443	1-249-437-11	CARBON	47K 5% 1/4W		C504	1-126-023-11 ELECT 100uF	20% 25V
R444	1-249-417-11	CARBON	1K 5% 1/4W		C505	1-162-211-31 CERAMIC 33PF	5% 50V
R445	1-249-419-11	CARBON	1.5K 5% 1/4W				
R446	1-247-883-00	CARBON	150K 5% 1/4W		C506	1-162-199-31 CERAMIC 10PF	5% 50V
R447	1-249-425-11	CARBON	4.7K 5% 1/4W		C507	1-136-158-00 FILM 0.027uF	5% 50V
R448	1-249-413-11	CARBON	470 5% 1/4W		C508	1-136-165-00 FILM 0.1uF	5% 50V
R449	1-249-424-11	CARBON	3.9K 5% 1/4W		C509	1-126-023-11 ELECT 100uF	20% 25V
R451	1-247-891-00	CARBON	330K 5% 1/4W		C510	1-136-165-00 FILM 0.1uF	5% 50V
R460	1-249-429-11	CARBON	10K 5% 1/4W				
R495	1-249-417-11	CARBON	1K 5% 1/4W		C511	1-126-023-11 ELECT 100uF	20% 25V
R496	1-249-417-11	CARBON	1K 5% 1/4W		C512	1-164-159-11 CERAMIC 0.1uF	50V
R497	1-247-903-00	CARBON	1M 5% 1/4W		C513	1-126-023-11 ELECT 100uF	20% 25V
R498	1-247-903-00	CARBON	1M 5% 1/4W		C514	1-136-165-00 FILM 0.1uF	5% 50V
R499	1-249-429-11	CARBON	10K 5% 1/4W		C515	1-130-834-00 FILM 1uF	10% 63V
					C516	1-136-165-00 FILM 0.1uF	5% 50V
					C517	1-164-159-11 CERAMIC 0.1uF	50V
					C520	1-164-159-11 CERAMIC 0.1uF	50V
						< CONNECTOR >	
					CN558	* 1-573-299-11 CONNECTOR, BOARD TO BOARD 10P	
						< DIODE >	
					D501	8-719-901-59 DIODE KV1320	
					D503	8-719-903-27 DIODE 1SS168	
						< IC >	
					IC501	8-759-604-30 IC M5F7808L	
					IC502	8-759-036-44 IC MC74AC74N	
					IC503	8-759-917-11 IC SN74HC393AN	
					IC504	8-759-250-81 IC TC5081AP	
						< COIL >	
					L501	1-460-042-11 COIL (WITH CORE)	

When indicating parts by reference number, please include the board name.

PLL	POWER
------------	--------------

Ref. No.	Part No.	Description	Remarks	Ref. No.	Part No.	Description	Remarks
L502	1-410-324-11	INDUCTOR	4. 7uH	C921	1-126-129-11	ELECT	6800uF 20% 35V
L503	1-410-324-11	INDUCTOR	4. 7uH	C922	1-164-159-11	CERAMIC	0. 1uF 50V
L504	1-410-324-11	INDUCTOR	4. 7uH	C923	1-164-159-11	CERAMIC	0. 1uF 50V
L505	1-460-042-11	COIL (WITH CORE)		C924	1-164-159-11	CERAMIC	0. 1uF 50V
		(TRANSISTOR)		C925	1-164-159-11	CERAMIC	0. 1uF 50V
Q501	8-729-200-56	TRANSISTOR	2SK241GR	C926	1-126-105-11	ELECT	1000uF 20% 35V
Q502	8-729-200-56	TRANSISTOR	2SK241GR	C927	1-126-105-11	ELECT	1000uF 20% 35V
Q503	8-729-900-61	TRANSISTOR	DTA114ES			(CONNECTOR)	
		(RESISTOR)		CN905	* 1-560-338-00	PIN, CONNECTOR	7P
R501	1-249-417-11	CARBON	1K 5% 1/4W	CN906	* 1-560-061-00	PIN, CONNECTOR	3P
R502	1-247-903-00	CARBON	1M 5% 1/4W	CN931	* 1-564-505-11	PLUG, CONNECTOR	2P
R503	1-247-903-00	CARBON	1M 5% 1/4W	CN932	* 1-564-511-11	PLUG, CONNECTOR	8P
R504	1-249-429-11	CARBON	10K 5% 1/4W	CN933	* 1-564-506-11	PLUG, CONNECTOR	3P
R505	1-249-428-11	CARBON	8. 2K 5% 1/4W			(DIODE)	
R506	1-249-441-11	CARBON	100K 5% 1/4W	D905	8-719-312-47	DIODE	RBA-406B
R507	1-249-417-11	CARBON	1K 5% 1/4W	D906	8-719-107-94	DIODE	1SS202-1
R508	1-249-417-11	CARBON	1K 5% 1/4W	D907	8-719-200-82	DIODE	11ES2
R509	1-249-417-11	CARBON	1K 5% 1/4W	D908	8-719-200-82	DIODE	11ES2
R510	1-249-407-11	CARBON	150 5% 1/4W	D909	8-719-934-15	DIODE	HZS24-3L
R511	1-249-425-11	CARBON	4. 7K 5% 1/4W	D910	8-719-933-33	DIODE	HZS6A1L
R512	1-249-425-11	CARBON	4. 7K 5% 1/4W	D911	8-719-230-02	DIODE	30D2-FC
R513	1-249-417-11	CARBON	1K 5% 1/4W	D912	8-719-230-02	DIODE	30D2-FC
R514	1-249-423-11	CARBON	3. 3K 5% 1/4W	D913	8-719-230-02	DIODE	30D2-FC
R515	1-249-423-11	CARBON	3. 3K 5% 1/4W	D914	8-719-230-02	DIODE	30D2-FC
R516	1-249-433-11	CARBON	22K 5% 1/4W	D915	8-719-107-94	DIODE	1SS202-1
R517	1-249-435-11	CARBON	33K 5% 1/4W	D916	8-719-107-94	DIODE	1SS202-1
R518	1-249-417-11	CARBON	1K 5% 1/4W			(FUSE)	
R519	1-249-417-11	CARBON	1K 5% 1/4W	F901	△ 1-532-744-11	FUSE, GLASS TUBE(2. 5A)	(US, CND)
		*****		F901	△ 1-532-286-11	FUSE, TIME-LAG(T2. 5A)	(57ES:AEP, E/750:UK)
		* A-2006-463-A POWER BOARD, COMPLETE				(IC)	
		*****		IC901	8-759-148-79	IC	uPC2406HF
		* 1-533-213-31 HOLDER, FUSE		IC902	8-759-231-53	IC	M5F7805L
		* 4-363-146-71 HEAT SINK, V. OUT		IC903	8-759-231-58	IC	M5F7812L
		7-682-147-15 SCREW, TR		IC904	8-759-604-51	IC	M5F7912L
		(CAPACITOR)				(TRANSISTOR)	
C907	1-126-946-11	ELECT	6800uF 20% 25V	Q901	8-729-140-97	TRANSISTOR	2SB734-34
C908	1-164-159-11	CERAMIC	0. 1uF 50V			(RESISTOR)	
C909	1-124-473-11	ELECT	1000uF 20% 10V	R901	1-249-425-11	CARBON	4. 7K 5% 1/4W
C910	1-164-159-11	CERAMIC	0. 1uF 50V	R902	△ 1-212-849-00	FUSIBLE	4. 7 5% 1/4W F
C911	1-164-159-11	CERAMIC	0. 1uF 50V	R903	1-249-421-11	CARBON	2. 2K 5% 1/4W
C912	1-124-473-11	ELECT	1000uF 20% 10V	R904	△ 1-212-865-00	FUSIBLE	22 5% 1/4W F
C913	1-126-104-11	ELECT	470uF 20% 35V	R905	1-249-433-11	CARBON	22K 5% 1/4W
C914	1-126-104-11	ELECT	470uF 20% 35V			(TRANSFORMER)	
C915	1-126-049-11	ELECT	22uF 20% 50V	T901	△ 1-450-556-11	TRANSFORMER, POWER	(US, CND)
C916	1-126-052-11	ELECT	100uF 20% 50V	T901	△ 1-450-557-11	TRANSFORMER, POWER	(57ES:AEP/750:UK)
C917	1-136-165-00	FILM	0. 1uF 5% 50V	T901	△ 1-450-558-11	TRANSFORMER, POWER	(57ES:E)
C918	1-130-834-00	FILM	1uF 10% 63V				
C919	1-136-165-00	FILM	0. 1uF 5% 50V				
C920	1-126-129-11	ELECT	6800uF 20% 35V				

The components identified by mark △ or dotted line with mark △ are critical for safety.
Replace only with part number specified.

Les composants identifiés par une marque △ sont critiques pour la sécurité.
Ne les remplacer que par une pièce portant le numéro spécifié.

When indicating parts by reference number, please include the board name.

RELAY**PRIMARY****REC VOL****REEL MOTOR****RF AMP**

Ref. No.	Part No.	Description	Remarks	Ref. No.	Part No.	Description	Remarks
* 1-639-332-11	RELAY BOARD	*****		C5	1-164-299-11	CERAMIC CHIP 0.22uF	10% 25V
*****				C6	1-164-004-11	CERAMIC CHIP 0.1uF	10% 25V
* 1-639-333-11	PRIMARY BOARD	*****		C7	1-163-009-11	CERAMIC CHIP 0.001uF	10% 50V
* 3-685-232-01	SPACER, VI			C8	1-124-778-00	ELECT CHIP 22uF	20% 6.3V
* 3-346-266-12	PLATE, GROUND			C9	1-124-778-00	ELECT CHIP 22uF	20% 6.3V
	< CAPACITOR >			C10	1-163-009-11	CERAMIC CHIP 0.001uF	10% 50V
C901	1-161-744-00	CAP, CERAMIC 0.01uF	400V	C11	1-164-004-11	CERAMIC CHIP 0.1uF	10% 25V
C902	1-161-742-00	CAP, CERAMIC 0.0022uF	20% 400V	C12	1-164-299-11	CERAMIC CHIP 0.22uF	10% 25V
C903	1-161-742-00	CAP, CERAMIC 0.0022uF	20% 400V	C13	1-162-638-11	CERAMIC CHIP 1uF	16V
C904	1-161-742-00	CAP, CERAMIC 0.0022uF	20% 400V	C14	1-163-117-00	CERAMIC CHIP 100PF	5% 50V
C905	1-161-742-00	CAP, CERAMIC 0.0022uF	20% 400V	C15	1-124-778-00	ELECT CHIP 22uF	20% 6.3V
		(57ES:AEP, E/750:UK)		C16	1-163-038-00	CERAMIC CHIP 0.1uF	25V
C906	1-161-744-00	CAP, CERAMIC 0.01uF	400V	C17	1-163-001-11	CERAMIC CHIP 220PF	10% 50V
	< CONNECTOR >			C18	1-163-117-00	CERAMIC CHIP 100PF	5% 50V
CN901	* 1-564-321-00	PIN, CONNECTOR 2P		C19	1-163-001-11	CERAMIC CHIP 220PF	10% 50V
	< COIL >			C20	1-164-182-11	CERAMIC CHIP 0.0033uF	10% 50V
L901	1-421-915-11	COIL, LINE FILTER		C21	1-163-005-11	CERAMIC CHIP 470PF	10% 50V
	< SWITCH >			C22	1-126-603-11	ELECT CHIP 4.7uF	20% 35V
SW901	* 1-571-722-11	SWITCH, VOLTAGE SELECTION		C23	1-163-117-00	CERAMIC CHIP 100PF	5% 50V
	(VOLTAGE SELECTOR) (57ES:E)			C24	1-163-038-00	CERAMIC CHIP 0.1uF	25V
*****				C25	1-124-778-00	ELECT CHIP 22uF	20% 6.3V
* 1-639-325-11	REC VOL BOARD	*****		C26	1-163-038-00	CERAMIC CHIP 0.1uF	25V
	< VARIABLE RESISTOR >			C27	1-162-638-11	CERAMIC CHIP 1uF	16V
RV102	1-238-833-21	RES, VAR, CARBON 20K/20K (REC LEVEL)		C28	1-164-505-11	CERAMIC CHIP 2.2uF	16V
*****					< CONNECTOR >		
* 1-639-304-11	REEL MOTOR BOARD	*****		CN51	* 1-566-207-11	PIN, CONNECTOR (PC BOARD) 14P	
	< CAPACITOR >			CN52	* 1-564-720-11	PIN, CONNECTOR (SMALL TYPE) 4P	
C07	1-163-077-00	CERAMIC CHIP 0.1uF	10% 25V		< IC >		
*****				IC1	8-752-039-01	IC CXA1364R	
* A-2001-587-A	RF AMP BOARD, COMPLETE	*****			< COIL >		
	< CAPACITOR >			L1	1-408-781-00	INDUCTOR CHIP 22uH	
C1	1-124-778-00	ELECT CHIP 22uF	20% 6.3V	L2	1-408-789-21	INDUCTOR, CHIP 100uH	
C2	1-163-019-00	CERAMIC CHIP 0.0068uF	10% 50V	L3	1-408-781-00	INDUCTOR CHIP 22uH	
C3	1-163-117-00	CERAMIC CHIP 100PF	5% 50V		< RESISTOR >		
C4	1-162-638-11	CERAMIC CHIP 1uF	16V	R1	1-216-082-00	METAL GLAZE 24K 5%	1/10W
				R2	1-216-082-00	METAL GLAZE 24K 5%	1/10W
				R3	1-216-066-00	METAL CHIP 5.1K 5%	1/10W
				R4	1-216-066-00	METAL CHIP 5.1K 5%	1/10W
				R5	1-216-077-00	METAL CHIP 15K 5%	1/10W
				R6	1-216-077-00	METAL CHIP 15K 5%	1/10W
				R7	1-216-077-00	METAL CHIP 15K 5%	1/10W
				R8	1-216-079-00	METAL CHIP 18K 5%	1/10W
				R9	1-216-075-00	METAL CHIP 12K 5%	1/10W
				R10	1-216-079-00	METAL CHIP 18K 5%	1/10W
				R11	1-216-077-00	METAL CHIP 15K 5%	1/10W
				R12	1-216-077-00	METAL CHIP 15K 5%	1/10W
				R13	1-216-077-00	METAL CHIP 15K 5%	1/10W
				R14	1-216-081-00	METAL CHIP 22K 5%	1/10W
				R15	1-216-234-00	METAL GLAZE 33K 5%	1/8W

When indicating parts by reference number, please include the board name.

RF AMP

RGN SW

SUB

SW (IN)

Ref. No.	Part No.	Description	Remarks
R16	1-216-238-00	METAL GLAZE 47K 5% 1/8W	
R17	1-216-080-00	METAL CHIP 20K 5% 1/10W	
R18	1-216-222-00	METAL GLAZE 10K 5% 1/8W	
(VARIABLE RESISTOR)			
RV1	1-238-181-11	RES, ADJ, CERMET 4.7K	
RV2	1-238-181-11	RES, ADJ, CERMET 4.7K	

* 1-639-301-11 RGN SW BOARD			

(SWITCH)			
S01	1-571-878-11	SWITCH, PUSH (2 KEY) (CASSETTE IN, REC PROOF)	

* A-2006-553-A SUB BOARD, COMPLETE			

(CAPACITOR)			
C332	1-136-153-00	FILM 0.01uF 5% 50V	
C333	1-130-473-00	MYLAR 0.0015uF 5% 50V	
C334	1-136-158-00	FILM 0.027uF 5% 50V	
C335	1-136-153-00	FILM 0.01uF 5% 50V	
C336	1-130-473-00	MYLAR 0.0015uF 5% 50V	
C337	1-136-158-00	FILM 0.027uF 5% 50V	
C338	1-162-306-11	CERAMIC 0.01uF 20% 16V	
C339	1-162-306-11	CERAMIC 0.01uF 20% 16V	
C340	1-162-290-31	CERAMIC 470PF 10% 50V	
C341	1-162-306-11	CERAMIC 0.01uF 20% 16V	
C342	1-126-059-11	ELECT 10uF 20% 63V	
C343	1-162-306-11	CERAMIC 0.01uF 20% 16V	
C344	1-162-306-11	CERAMIC 0.01uF 20% 16V	
C348	1-130-834-00	FILM 1uF 10% 63V	
(CONNECTOR)			
CN556	1-573-300-11	CONNECTOR, BOARD TO BOARD 18P	
(IC)			
IC316	8-759-135-80	IC uPC358C	
IC317	8-759-135-80	IC uPC358C	
IC318	8-759-135-80	IC uPC358C	
(TRANSISTOR)			
Q302	8-729-801-93	TRANSISTOR 2SD1387	
Q333	8-729-924-90	TRANSISTOR 2SB1370-EF	
Q334	8-729-920-68	TRANSISTOR 2SA933S-QR	
Q335	8-729-119-78	TRANSISTOR 2SC2785-HFE	
Q336	8-729-927-11	TRANSISTOR 2SA1585S-QR	
Q337	8-729-927-11	TRANSISTOR 2SA1585S-QR	
Q338	8-729-927-12	TRANSISTOR 2SC4115S-QR	

Ref. No.	Part No.	Description	Remarks
Q339	8-729-927-12	TRANSISTOR 2SC4115S-QR	
Q340	8-729-119-78	TRANSISTOR 2SC2785-HFE	
Q341	8-729-119-78	TRANSISTOR 2SC2785-HFE	
Q342	8-729-209-15	TRANSISTOR 2SD2012	
(RESISTOR)			
R337	1-249-429-11	CARBON 10K 5% 1/4W	
R338	1-249-433-11	CARBON 22K 5% 1/4W	
R339	1-249-401-11	CARBON 47 5% 1/4W	
R340	1-249-429-11	CARBON 10K 5% 1/4W	
R341	1-249-429-11	CARBON 10K 5% 1/4W	
R342	1-249-429-11	CARBON 10K 5% 1/4W	
R343	1-249-438-11	CARBON 56K 5% 1/4W	
R344	1-249-438-11	CARBON 56K 5% 1/4W	
R345	1-249-438-11	CARBON 56K 5% 1/4W	
R352	1-249-441-11	CARBON 100K 5% 1/4W	
R354	1-249-441-11	CARBON 100K 5% 1/4W	
R355	1-249-417-11	CARBON 1K 5% 1/4W	
R356	1-249-417-11	CARBON 1K 5% 1/4W	
R357	1-249-405-11	CARBON 100 5% 1/4W	
R358	1-249-417-11	CARBON 1K 5% 1/4W	
R359	1-249-408-11	CARBON 180 5% 1/4W	
R360	1-247-870-11	CARBON 43K 5% 1/4W	
R361	1-249-437-11	CARBON 47K 5% 1/4W	
R364	1-247-731-11	CARBON 22 5% 1/2W	
R366	1-249-441-11	CARBON 100K 5% 1/4W	
R367	1-249-417-11	CARBON 1K 5% 1/4W	
R368	1-249-417-11	CARBON 1K 5% 1/4W	
R369	1-249-405-11	CARBON 100 5% 1/4W	
R370	1-249-405-11	CARBON 100 5% 1/4W	
R371	1-249-417-11	CARBON 1K 5% 1/4W	
R372	1-249-405-11	CARBON 100 5% 1/4W	
R373	1-249-417-11	CARBON 1K 5% 1/4W	
R374	1-249-417-11	CARBON 1K 5% 1/4W	
R375	1-249-405-11	CARBON 100 5% 1/4W	
R376	1-249-417-11	CARBON 1K 5% 1/4W	
R377	1-249-441-11	CARBON 100K 5% 1/4W	
R382	1-249-441-11	CARBON 100K 5% 1/4W	
R383	1-249-401-11	CARBON 47 5% 1/4W	
R384	1-249-437-11	CARBON 47K 5% 1/4W	
R385	1-249-437-11	CARBON 47K 5% 1/4W	

* 1-639-647-11 SW (IN) BOARD

(SWITCH)

S12 1-572-247-11 SWITCH, SLIDE (CASSETTE TABLE OUT)

When indicating parts by reference number, please include the board name.

SW (OUT)

TIMER SW

TOP END SENSOR

Ref.No.	Part No.	Description	Remarks
	* 1-639-648-11	SW (OUT) BOARD ***** (SWITCH)	
S11	1-570-975-11	SWITCH, SLIDE (CASSETTE TABLE IN)	

	* 1-639-329-11	TIMER SW BOARD ***** (IC)	
IC704	8-749-922-36	IC GP1U50XB (RESISTOR)	
R711	1-249-428-11	CARBON 8.2K 5% 1/4W	
R712	1-249-434-11	CARBON 27K 5% 1/4W	
		(SWITCH)	
S701	1-571-520-11	SWITCH, SLIDE (TIMER)	
S703	1-570-974-11	SWITCH, SLIDE (REC MODE)	

	* 1-639-305-11	TOP END SENSOR BOARD *****	
	* 3-368-456-01	HOLDER (END SENSOR LIGHT)	
	* 3-368-457-01	HOLDER (END SENSOR) (RECIEVE)	
		(DIODE)	
D01	8-719-951-03	DIODE GL453 (PHOTO INTERRUPTER)	
PH03	8-729-907-25	PT4850F	
PH04	8-729-907-25	PT4850F	

Ref.No.	Part No.	Description	Remarks
		MISCELLANEOUS *****	
10	△ 1-559-297-31	CODE, POWER (57ES:E)	
10	△ 1-559-479-11	CORD, POWER (57ES:US, CND)	
10	△ 1-575-695-11	CODE, POWER (750:US, CND)	
10	△ 1-575-912-11	CODE, POWER (57ES:AEP)	
10	△ 1-575-913-11	CODE, POWER (750:UK)	
108	1-590-915-11	WIRE, FLAT TYPE (30 CORE)	
109	1-590-916-11	WIRE, FLAT TYPE (10 CORE)	
110	1-590-914-11	WIRE, FLAT TYPE (6 CORE)	
325	8-848-567-01	DRUM ASSY DOU-03A	
382	1-454-535-11	SOLENOID, PLUNGER (BRAKE)	
383	1-454-536-11	SOLENOID, PLUNGER (BT CONTROL)	
69	1-518-634-11	LAMP, PILOT	
76	1-554-920-21	SWITCH, PUSH (AC POWER) (1 KEY)	
77	1-590-321-71	LEAD (WITH CONNECTOR)	
BAT301	△ 1-528-229-11	BATTERY, LITHIUM CR-2450	
M901	A-2003-448-A	MOTOR ASSY (CASSETTE COM)	
M902	8-835-361-01	MOTOR, DC U-17B (CAPSTAN)	
M903	X-3363-109-1	MOTOR (CAM) ASSY	
M905	X-3363-110-1	MOTOR (REEL) ASSY	

		ACCESSORIES & PACKING MATERIALS *****	
	1-465-737-11	REMOTE COMMANDER (RM-D57A) (BLACK)	
	1-465-777-11	REMOTE COMMANDER (RM-D57A) (GOLD)	
	1-559-533-11	CORD, CONNECTION	
*	3-369-495-01	INDIVIDUAL CARTON	
	3-703-450-01	INSTRUCTION (US)	
	3-704-366-01	SCREW (CASE) (M3X8)	
	3-707-584-01	COVER, BATTERY (for RM-D57A)	
	3-753-349-11	MANUAL, INSTRUCTION (57ES:AEP, E) (English, French, Spanish, Portuguese)	
	3-753-349-21	MANUAL, INSTRUCTION (750:US, CND, UK) (English)	
	3-753-349-31	MANUAL, INSTRUCTION (750:CND) (French)	
	3-753-349-41	MANUAL, INSTRUCTION (57ES:AEP) (German, Dutch, Swedish, Italian)	
	3-753-349-51	MANUAL, INSTRUCTION (57ES:AEP) (Danish, Finnish)	
	3-753-350-21	MANUAL, INSTRUCTION (57ES:US, CND) (English)	
	3-753-350-31	MANUAL, INSTRUCTION (57ES:CND) (French)	
*	4-936-624-01	CUSHION	

The components identified by mark △ or dotted line with mark △ are critical for safety.
Replace only with part number specified.

Les composants identifiés par une marque △ sont critiques pour la sécurité.
Ne les remplacer que par une pièce portant le numéro spécifié.

When indicating parts by reference number, please include the board name.

Ref. No.	Part No.	Description	Remarks
----------	----------	-------------	---------

HARDWARE LIST

#1	7-682-548-09	SCREW +BVTT 3X8 (S)	
#2	7-683-412-05	BOLT, HEXAGON SOCKET 2.6X6	
#3	7-685-646-79	SCREW +BVTP 3X8 TYPE2 N-S	
#4	7-685-647-79	SCREW, TAPPING (M3X10)	
#5	7-682-547-04	SCREW +BVTT 3X6 (S)	
#6	7-682-560-04	SCREW +BVTT 4X6 (S)	
#7	7-621-772-10	SCREW +B 2X4	
#8	7-621-772-00	SCREW +B 2X3	
#9	7-682-545-09	SCREW +B 3X4	
#10	7-621-255-45	SCREW +P 2X6	
#11	7-621-775-08	SCREW +B 2.6X3	
#12	7-621-773-86	SCREW +B 2.6X4	
#13	7-621-775-20	SCREW +B 2.6X5	
#14	7-682-147-15	SCREW, TR	
#15	7-621-255-20	SCREW +BVTT 2X4 (S)	
#16	7-627-854-07	PRECISION SCREW +P 2X2.5 TYPE3	
#17	7-627-556-17	SCREW, PRECISION +P 2.6X3 TYPE1	
#18	7-627-852-27	+P 1.7X3	
#19	7-621-255-15	SCREW +P 2X3	
#20	7-627-552-27	SCREW, PRECISION +P 1.7X2	
#21	7-627-552-47	SCREW, PRECISION +P 1.7X4	
#22	7-621-772-08	SCREW +B 2X3	
#23	7-621-772-18	SCREW +B 2X4	
#24	7-685-133-19	SCREW +BTP 2.6X6 TYPE2 N-S	
#25	7-685-534-19	SCREW +BTP 2.6X8 TYPE2 N-S	
#26	7-682-550-09	SCREW +BVTT 3X12 (S)	

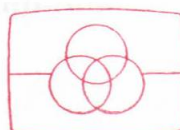

Free service manuals

Gratis schema's

Digitized by

www.freeservicemanuals.info

DTC-57ES/750

SONY SERVICE MANUAL

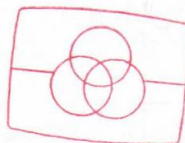

Free service manuals
Gratis schema's

Digitized by

www.freesevicemanuals.info

US Model

Canadian Model

AEP Model

E Model

DTC-57ES

US Model

Canadian Model

UK Model

DTC-750

SUPPLEMENT-2

File this supplement with the service manual.

1. Service Manual Correction
2. FWD torque adjustment procedure change
3. Circuit design and board change (SUB board)
4. Addition part and change of part

1. Service Manual Correction

 : Corrected portion

Page	Incorrect	Correct
15	<p>FWD Torque Adjustment Adjustment Procedure:</p> <p>3. Confirm that the FWD torque value (take-up side rewinding torque) is between 10 – 20 g·cm (0.14 – 0.28 oz·inch).</p>	<p>FWD Torque <u>Check</u> <u>Check</u> Procedure:</p> <p>3. Confirm that the FWD torque value (take-up side rewinding torque) is between 10 – <u>16</u> g·cm (0.14 – <u>0.22</u> oz·inch).</p>
15	<p>FWD Back Tension Check Check procedure:</p> <p>3. Confirm that the back tension (supply side) is between 5 – 6 g·cm (0.07 – 0.09 oz·inch). If this is not satisfied, adjust back tension by rotating the FWD back tension adjustment screw equipped on the side surface of the mechanical deck. After completion of adjusting, be sure to apply screw lock.</p>	<p>FWD Back Tension <u>Adjustment</u> <u>Adjustment</u> procedure:</p> <p>3. <u>Turn the FWD back tension adjustment screw locked on the mechanical deck side so that the minimum value of FWD back tension torque (supply side) is between 4 – 5 g·cm (0.06 – 0.07 oz·inch).</u> <u>Also, make sure that the maximum reading does not exceed 8 g·cm (does not exceed 0.11 oz·inch).</u> After completion of adjusting, be sure to apply screw lock.</p>

2. FWD torque adjustment procedure change (Except US model)

		Serial Number
DTC-57ES	Canadian model	A700, 101 and later
	AEP model (Black Type)	519, 501 and later
	AEP model (Gold Type)	503, 201 and later
	E model	302, 001 and later
DTC-750	Canadian model	A700, 501 and later
	UK model	603, 201 and later

- Sets with the serial numbers shown above have a new variable resistor (RV301) on the sub board which serves for FWD torque adjustment. The adjustment for these sets should therefore be carried out as described below.

FWD Torque Adjustment:

Adjustment procedure:

- Put the set into the test mode (main · servo) and load the FWD torque meter TW-7131 (8-909-708-71)
- Put the set into the PLAY (▶) mode.
- Adjust RV301 so that the minimum value of FWD take up torque (take-up side rewinding torque) is between 10 – 11 g·cm (0.14 – 0.15 oz·inch).
Also, make sure that the maximum reading does not exceed 16 g·cm (does not exceed 0.22 oz·inch).
- Confirm that the value indicated by the torque meter is maintained for one full cycle.

Adjustment point:

– SUB board – (Component side)

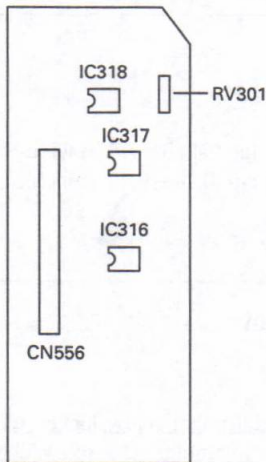

3. Circuit design and board change (SUB board) (Except US model)

Printed Wiring Board

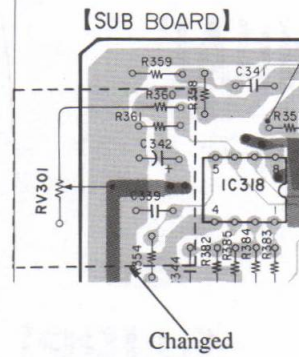

Schematic Diagram

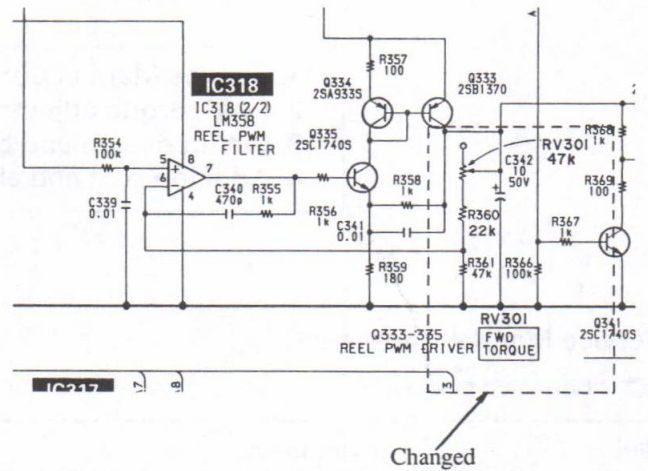

4. Additional part and change of part (Except US model)

Page	Former	New	Remarks
-	-	RV301 1-238-019-11 RES, ADJ, METAL 47K (FWD TORQUE)	Addition
74	R360 43K	R360 1-249-433-11 CARBON 22K 5% 1/4W	Change

DTC-57ES/750

SONY SERVICE MANUAL

US Model
Canadian Model
AEP Model
E Model
DTC-57ES
US Model
Canadian Model
UK Model
DTC-750

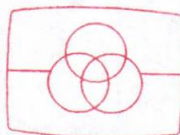

Free service manuals
Gratis schema's

Digitized by

www.freeservicemanuals.info

SUPPLEMENT-1

File this supplement with the Service Manual.

Design change of the Mechanism section (DATM-100)

The T2 roller guide has been changed to a fixed guide by the design change (to improve reliability), while the composition of the lever (F/R) assy also being modified as shown on the following page.

 : Altered portion

Page	Incorrect	Correct																
6																		
<table border="1"> <thead> <tr> <th>Ref. No.</th> <th>Part No.</th> <th>Description</th> <th>Remarks</th> </tr> </thead> <tbody> <tr> <td>335</td> <td>3-375-209-01</td> <td>SHAFT (FIXED GUIDE)</td> <td></td> </tr> <tr> <td>336</td> <td>3-337-677-01</td> <td>FLANGE</td> <td></td> </tr> <tr> <td>337</td> <td>3-337-676-01</td> <td>GUIDE, FIXED</td> <td></td> </tr> </tbody> </table>			Ref. No.	Part No.	Description	Remarks	335	3-375-209-01	SHAFT (FIXED GUIDE)		336	3-337-677-01	FLANGE		337	3-337-676-01	GUIDE, FIXED	
Ref. No.	Part No.	Description	Remarks															
335	3-375-209-01	SHAFT (FIXED GUIDE)																
336	3-337-677-01	FLANGE																
337	3-337-676-01	GUIDE, FIXED																

7																														
<table border="1"> <thead> <tr> <th>Ref. No.</th> <th>Part No.</th> <th>Description</th> <th>Remarks</th> </tr> </thead> <tbody> <tr> <td>367</td> <td>3-578-224-00</td> <td>WASHER</td> <td></td> </tr> <tr> <td>369</td> <td>3-368-450-01</td> <td>LEVER (F/R)</td> <td></td> </tr> <tr> <td>371</td> <td>3-368-429-01</td> <td>SHAFT (NECK)</td> <td></td> </tr> <tr> <td>372</td> <td>3-368-422-01</td> <td>POLY-SLIDER (DIA. 4.5-DIA. 1.5)</td> <td></td> </tr> <tr> <td>373</td> <td>3-368-437-01</td> <td>SPRING (GEAR NECK), COMPRESSION</td> <td></td> </tr> <tr> <td>374</td> <td>3-368-406-01</td> <td>GEAR (NECK)</td> <td></td> </tr> </tbody> </table>			Ref. No.	Part No.	Description	Remarks	367	3-578-224-00	WASHER		369	3-368-450-01	LEVER (F/R)		371	3-368-429-01	SHAFT (NECK)		372	3-368-422-01	POLY-SLIDER (DIA. 4.5-DIA. 1.5)		373	3-368-437-01	SPRING (GEAR NECK), COMPRESSION		374	3-368-406-01	GEAR (NECK)	
Ref. No.	Part No.	Description	Remarks																											
367	3-578-224-00	WASHER																												
369	3-368-450-01	LEVER (F/R)																												
371	3-368-429-01	SHAFT (NECK)																												
372	3-368-422-01	POLY-SLIDER (DIA. 4.5-DIA. 1.5)																												
373	3-368-437-01	SPRING (GEAR NECK), COMPRESSION																												
374	3-368-406-01	GEAR (NECK)																												
<table border="1"> <thead> <tr> <th>Ref. No.</th> <th>Part No.</th> <th>Description</th> <th>Remarks</th> </tr> </thead> <tbody> <tr> <td>369</td> <td>X-3364-581-1</td> <td>LEVER (F/R) ASSY</td> <td></td> </tr> </tbody> </table>			Ref. No.	Part No.	Description	Remarks	369	X-3364-581-1	LEVER (F/R) ASSY																					
Ref. No.	Part No.	Description	Remarks																											
369	X-3364-581-1	LEVER (F/R) ASSY																												

DTC-57ES/750

SONY SERVICE MANUAL

US Model
 Canadian Model
 AEP Model
 E Model
 DTC-57ES
 US Model
 Canadian Model
 UK Model
 DTC-750

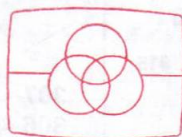

Free service manuals
 Gratis schema's

Digitized by

www.freesevicemanuals.info

CORRECTION-1

Correct your service manual as shown below.

: Corrected portion

Page	Incorrect	Correct
37		
62		

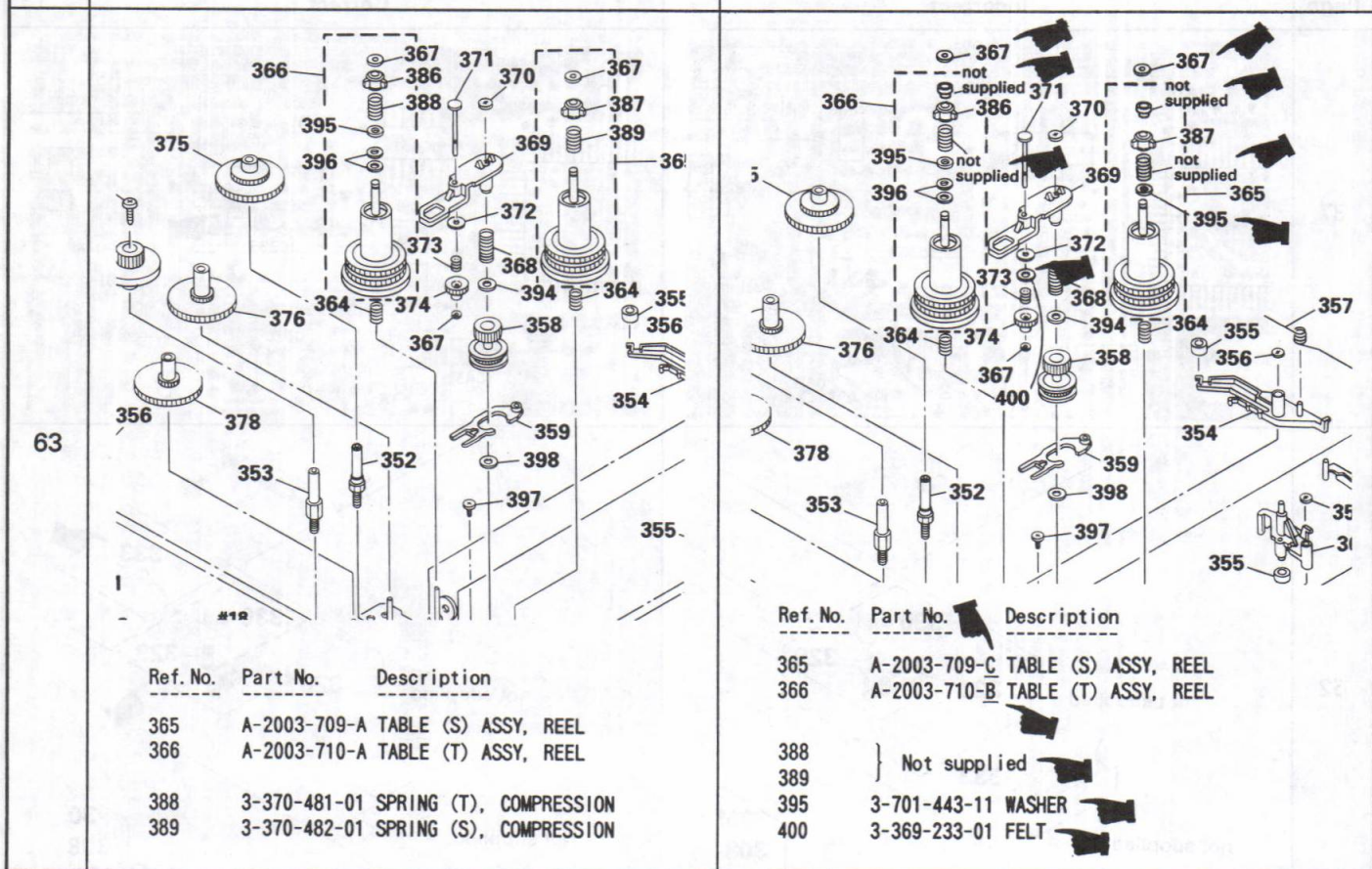
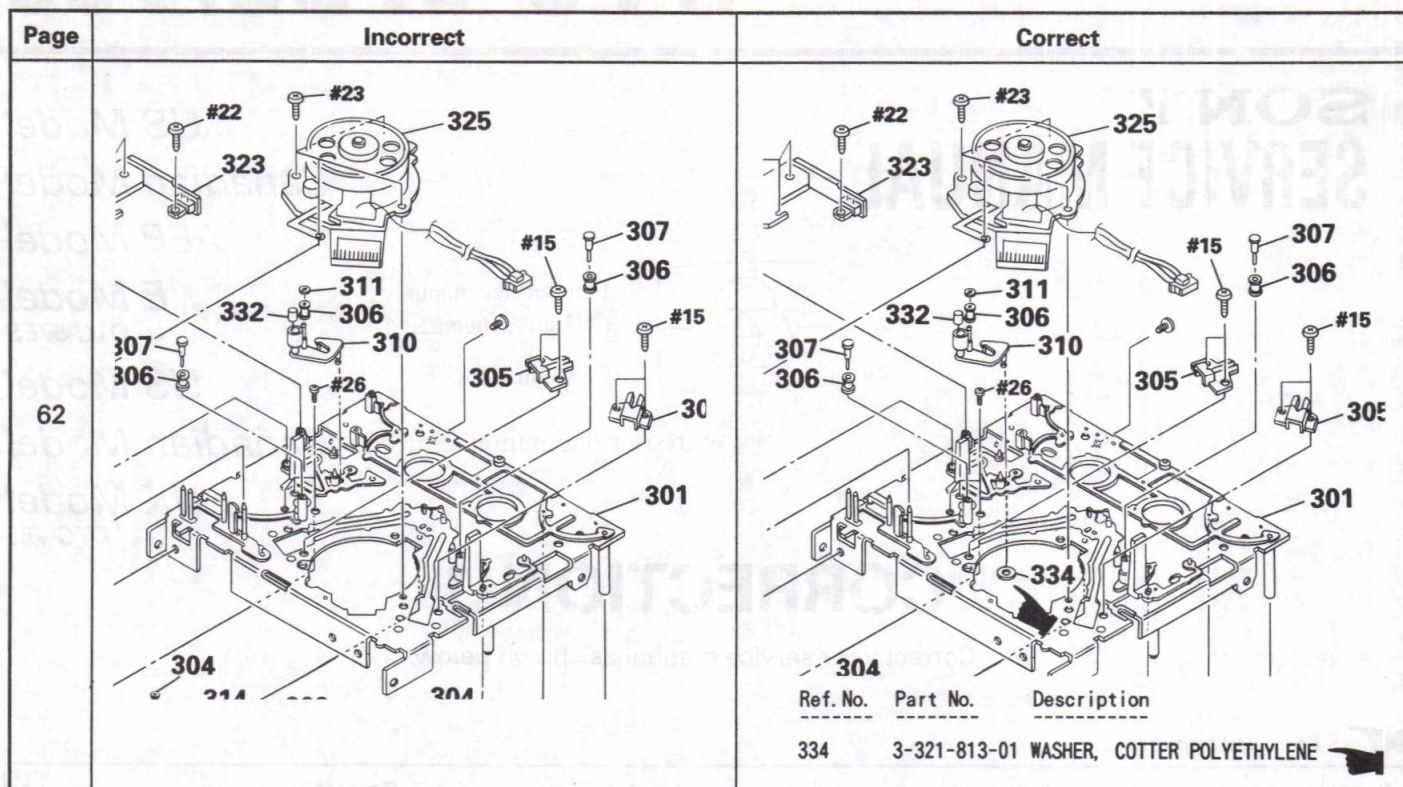

DTC-57ES/750

SONY SERVICE MANUAL

US Model
Canadian Model
AEP Model
E Model
DTC-57ES
US Model
Canadian Model
UK Model
DTC-750

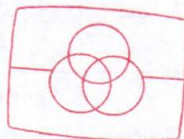

Free service manuals
Gratis schema's

Digitized by

www.freesevicemanuals.info





CORRECTION-2

Correct your service manual as shown below.

 : Corrected portion

Page	Incorrect	Correct
13	<p>7. Test mode The test mode is effected by shorting TP (XTEST MAIN, XTEST SERVO and XTEST DISP) on the main board and the operation switch board and GND.</p> <p>(1) Test mode (main) Turn OFF the main switch, connect XTEST MAIN on the main board to GND and perform the following adjustments.</p> <ul style="list-style-type: none"> • Tape path adjustment • DPG adjustment • ATF pilot (GCA) checking <p>(2) Test mode (servo) Turn OFF the main switch, connect XTEST SERVO on the main board to GND and perform the following adjustments.</p> <ul style="list-style-type: none"> • End sensor checking • FWD torque checking • FWD back tension checking <p>(3) Test mode (display) You can check the following FL display tube and the panel switch by turning OFF the main switch, disconnecting CN932 on the power board, removing flexible board CN752 on the operation switch board, connecting XTEST DISP to GND, connecting CN932 again and then turning ON the main switch.</p>	<p>7. Test mode The test mode is effected by shorting TP (XTEST MAIN, XTEST SERVO and XTEST DISP) on the main board and the operation switch board and GND.</p> <p>(1) Test mode (<u>main · servo</u>) Turn OFF the main switch, connect XTEST MAIN and <u>XTEST SERVO</u> on the main board to GND and perform the following adjustments.</p> <ul style="list-style-type: none"> • Tape path adjustment • DPG adjustment • ATF pilot (GCA) checking • End sensor checking • FWD torque checking • FWD back tension checking <p>(2) Test mode (display) You can check the following FL display tube and the panel switch by turning OFF the main switch, disconnecting CN932 on the power board, removing flexible board CN752 on the operation switch board, connecting XTEST DISP to GND, connecting CN932 again and then turning ON the main switch.</p>
15	<p>End Sensor Adjustment</p> <p>2. Actuate the test mode (servo), mount an end sensor cassette and effect the STOP (■) mode.</p>	<p>End Sensor Adjustment</p> <p>2. Actuate the test mode (<u>main · servo</u>), mount an end sensor cassette and effect the STOP (■) mode.</p>
	<p>FWD Torque Adjustment Adjustment Procedure:</p> <p>1. Put the set into the test mode and load the FWD torque meter TW-7131 (8-909-708-71).</p>	<p>FWD Torque Adjustment Adjustment Procedure:</p> <p>1. Put the set into the test mode (<u>main · servo</u>) and load the FWD torque meter TW-7131 (8-909-708-71).</p>
	<p>FWD Back Tension Check Check procedure:</p> <p>1. Put the set into the test mode and load the FWD torque meter TW-7131 (8-909-708-71)</p>	<p>FWD Back Tension Check Check procedure:</p> <p>1. Put the set into the test mode (<u>main · servo</u>) and load the FWD torque meter TW-7131 (8-909-708-71)</p>

 : Corrected portion

Page	Incorrect	Correct																																																
15	Tape Path Fine Adjustments (× 1.5 FWD Mode) 2. Put the set into the test mode and load test tape TY-7252 (8-909-822-00).	Tape Path Fine Adjustments (× 1.5 FWD Mode) 2. Put the set into the test mode (<u>main · servo</u>) and load test tape TY-7252 (8-909-822-00). 																																																
16	DPG Adjustment 2. Put the set into the test mode and load test tape TY-7252 (8-909-822-00).	DPG Adjustment 2. Put the set into the test mode (<u>main · servo</u>) and load test tape TY-7252 (8-909-822-00). 																																																
	ATF Pilot (GCA) Adjustment 2. Put the set into the test mode and load test tape TY-7111 (8-909-812-00).	ATF Pilot (GCA) Adjustment 2. Put the set into the test mode (<u>main · servo</u>) and load test tape TY-7111 (8-909-812-00). 																																																
55	IC363 Digital Filter (CXD2560M) The Filter is a digital audio 8x oversampling digital filter with builtin L/R 2ch filter, noise shaping attenuator, soft muting deemphasis, etc. <table border="1" data-bbox="163 741 739 1042"> <thead> <tr> <th>Pin No.</th> <th>Pin Name</th> <th>I/O</th> <th>Description</th> </tr> </thead> <tbody> <tr> <td>1</td> <td>Vss</td> <td>—</td> <td>Power terminal (GND)</td> </tr> <tr> <td>2</td> <td>SYSM</td> <td>I</td> <td>System mute input. Effective upon "H"</td> </tr> <tr> <td>3</td> <td>ATT</td> <td>I</td> <td>ATT data input in CTL "L." EMP input upon CLT "H."</td> </tr> <tr> <td>4</td> <td>SHIFT</td> <td>I</td> <td>Shift clock input upon CTL "L." FS32 input upon CTL "H."</td> </tr> <tr> <td>5</td> <td>LATCH</td> <td>I</td> <td>Latch clock input upon CTL "L." FS48 input upon CLT "H."</td> </tr> </tbody> </table>	Pin No.	Pin Name	I/O	Description	1	Vss	—	Power terminal (GND)	2	SYSM	I	System mute input. Effective upon "H"	3	ATT	I	ATT data input in CTL "L." EMP input upon CLT "H."	4	SHIFT	I	Shift clock input upon CTL "L." FS32 input upon CTL "H."	5	LATCH	I	Latch clock input upon CTL "L." FS48 input upon CLT "H."	IC363 Digital Filter (CXD2560M) The Filter is a digital audio 8x oversampling digital filter with builtin L/R 2ch filter, noise shaping attenuator, soft muting deemphasis, etc. <table border="1" data-bbox="810 741 1386 1042"> <thead> <tr> <th>Pin No.</th> <th>Pin Name</th> <th>I/O</th> <th>Description</th> </tr> </thead> <tbody> <tr> <td>1</td> <td>Vss</td> <td>—</td> <td>Power terminal (GND)</td> </tr> <tr> <td>2</td> <td>SYSM</td> <td>I</td> <td>System mute input. Effective upon "H"</td> </tr> <tr> <td>3</td> <td>ATT</td> <td>I</td> <td>ATT data input in CTL "L." EMP input upon <u>CTL</u> "H."</td> </tr> <tr> <td>4</td> <td>SHIFT</td> <td>I</td> <td>Shift clock input upon CTL "L." FS32 input upon CTL "H."</td> </tr> <tr> <td>5</td> <td>LATCH</td> <td>I</td> <td>Latch clock input upon CTL "L." FS48 input upon <u>CTL</u> "H."</td> </tr> </tbody> </table>	Pin No.	Pin Name	I/O	Description	1	Vss	—	Power terminal (GND)	2	SYSM	I	System mute input. Effective upon "H"	3	ATT	I	ATT data input in CTL "L." EMP input upon <u>CTL</u> "H."	4	SHIFT	I	Shift clock input upon CTL "L." FS32 input upon CTL "H."	5	LATCH	I	Latch clock input upon CTL "L." FS48 input upon <u>CTL</u> "H."
	Pin No.	Pin Name	I/O	Description																																														
1	Vss	—	Power terminal (GND)																																															
2	SYSM	I	System mute input. Effective upon "H"																																															
3	ATT	I	ATT data input in CTL "L." EMP input upon CLT "H."																																															
4	SHIFT	I	Shift clock input upon CTL "L." FS32 input upon CTL "H."																																															
5	LATCH	I	Latch clock input upon CTL "L." FS48 input upon CLT "H."																																															
Pin No.	Pin Name	I/O	Description																																															
1	Vss	—	Power terminal (GND)																																															
2	SYSM	I	System mute input. Effective upon "H"																																															
3	ATT	I	ATT data input in CTL "L." EMP input upon <u>CTL</u> "H."																																															
4	SHIFT	I	Shift clock input upon CTL "L." FS32 input upon CTL "H."																																															
5	LATCH	I	Latch clock input upon CTL "L." FS48 input upon <u>CTL</u> "H."																																															
	<table border="1" data-bbox="163 1064 739 1228"> <tbody> <tr> <td>16</td> <td>INVO2</td> <td>O</td> <td>Inverter output</td> </tr> <tr> <td>17</td> <td>MCLK</td> <td>I</td> <td>Master clock input (f=512Fs)</td> </tr> <tr> <td>18</td> <td>VDD</td> <td>—</td> <td>Power terminal (+2 V)</td> </tr> <tr> <td>19</td> <td>BCKO</td> <td>O</td> <td>BCK output</td> </tr> <tr> <td>20</td> <td>DL</td> <td>O</td> <td>Lch data output</td> </tr> </tbody> </table>	16	INVO2	O	Inverter output	17	MCLK	I	Master clock input (f=512Fs)	18	VDD	—	Power terminal (+2 V)	19	BCKO	O	BCK output	20	DL	O	Lch data output	<table border="1" data-bbox="810 1064 1386 1228"> <tbody> <tr> <td>16</td> <td>INVO2</td> <td>O</td> <td>Inverter output</td> </tr> <tr> <td>17</td> <td>MCLK</td> <td>I</td> <td>Master clock input (f=512Fs)</td> </tr> <tr> <td>18</td> <td>VDD</td> <td>—</td> <td>Power terminal (<u>+5 V</u>)</td> </tr> <tr> <td>19</td> <td>BCKO</td> <td>O</td> <td>BCK output</td> </tr> <tr> <td>20</td> <td>DL</td> <td>O</td> <td>Lch data output</td> </tr> </tbody> </table> 	16	INVO2	O	Inverter output	17	MCLK	I	Master clock input (f=512Fs)	18	VDD	—	Power terminal (<u>+5 V</u>)	19	BCKO	O	BCK output	20	DL	O	Lch data output								
16	INVO2	O	Inverter output																																															
17	MCLK	I	Master clock input (f=512Fs)																																															
18	VDD	—	Power terminal (+2 V)																																															
19	BCKO	O	BCK output																																															
20	DL	O	Lch data output																																															
16	INVO2	O	Inverter output																																															
17	MCLK	I	Master clock input (f=512Fs)																																															
18	VDD	—	Power terminal (<u>+5 V</u>)																																															
19	BCKO	O	BCK output																																															
20	DL	O	Lch data output																																															

DTC-57ES/750

SONY SERVICE MANUAL

US Model
Canadian Model
AEP Model
E Model
DTC-57ES

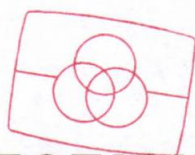

Free service manuals
Gratis schema's

CORRECTION-3

Digitized by
www.freeservicemanuals.info

Correct your service manual as shown below.

US Model
Canadian Model
UK Model
DTC-750

 : indicates corrected portion.

Page	INCORRECT			CORRECT		
	No.	Part No.	Description	No.	Part No.	Description
61	216	*1-639-647-11	SW(IN) BOARD	*1-639-648-11		SW(OUT) BOARD
	217	*1-639-648-11	SW(OUT) BOARD	*1-639-647-11		SW(IN) BOARD
	S11	1-570-975-11	SWITCH, SLIDE (CASSETTE TABLE OUT)	1-572-247-11		SWITCH, SLIDE (CASSETTE TABLE IN)
	S12	1-572-247-11	SWITCH, SLIDE (CASSETTE TABLE IN)	1-570-975-11		SWITCH, SLIDE (CASSETTE TABLE OUT)
74	S12	1-572-247-11	SWITCH, SLIDE (CASSETTE TABLE OUT)	S11	1-572-247-11	SWITCH, SLIDE (CASSETTE TABLE IN)
75	S11	1-570-975-11	SWITCH, SLIDE (CASSETTE TABLE IN)	S12	1-570-975-11	SWITCH, SLIDE (CASSETTE TABLE OUT)

DTC-57ES/750

SONY SERVICE MANUAL

US Model
Canadian Model
DTC-57ES/DTC-750

AEP Model
E Model
DTC-57ES

UK Model
DTC-750

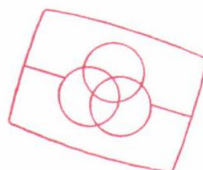

Free service manuals
Gratis schema's

CORRECTION-4

Correct your service manual as shown below

: indicates corrected portion.

Page	INCORRECT	CORRECT
62		

