

# DTC-ZA5ES

## SERVICE MANUAL

AEP Model

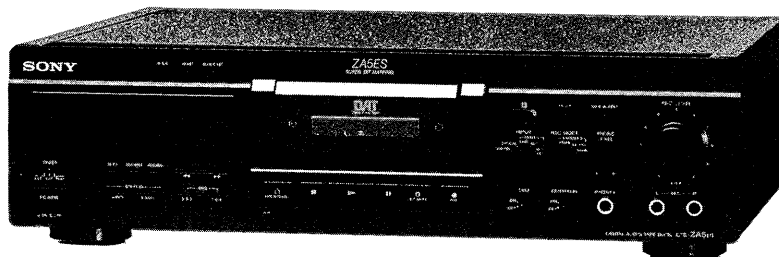

PHOTO : BLACK

Model Name Using Similar Mechanism	DTC-A8
Tape Transport Mechanism Type	DATM-55

### SPECIFICATIONS

#### System

<b>Tape</b>	Digital audio tape
<b>Recording head</b>	Rotary head
<b>Recording time (when using DT-120)</b>	Standard: 120 minutes Long-play: 240 minutes
<b>Tape speed</b>	Standard: 8.15 mm/s Long-play: 4.075 mm/s
<b>Drum rotation</b>	Standard: 2,000 rpm Long-play: 1,000 rpm
<b>Track pitch</b>	13.6 $\mu$ m (20.4 $\mu$ m)
<b>Sampling frequency</b>	48 kHz, 44.1 kHz, 32 kHz
<b>Number of channels</b>	2 channels, stereo
<b>D / A conversion (quantization)</b>	Standard: 16-bit linear Long-play: 12-bit non-linear
<b>Frequency response</b>	Standard: 2-22,000 Hz ( $\pm 0.5$ dB) Long-play: 2-14,500 Hz ( $\pm 0.5$ dB)
<b>Signal-to-noise ratio</b>	93 dB or more (Standard and long-play mode)
<b>Dynamic range</b>	93 dB or more (Standard and long-play mode)
<b>Total harmonic distortion</b>	Standard: 0.0045% or less (1 kHz) Long-play: 0.08% or less (1 kHz)
<b>Wow and flutter</b>	Below measurable limit ( $\pm 0.001\%$ W.PEAK)

#### Input Connectors

Connector	Jack type	Input impedance	Rated input level
ANALOG (LINE)	Phono jacks	47 kilohms	-4 dBs
MIC L/R	Standard Jack	5 kilohms	-60 dBs
DIGITAL OPTICAL	Optical connector	—	—
DIGITAL COAXIAL	Phono jack	75 ohms	0.5 Vp-p

#### Output Connectors

Connector	Jack type	Output impedance	Rated output level	Load impedance
ANALOG (LINE)	Phono jacks	470 ohms	-4 dBs	10 kilohms or more
DIGITAL OPTICAL	Optical connector	—	(wavelength 660 nm)	—
DIGITAL COAXIAL	Phono jack	75 ohms	0.5 Vp-p	75 ohms
HEADPHONES	Stereo phone-plug jack	100 ohms	1.2 mW	32 ohms

#### General section

<b>Power requirements</b>	220 - 230 V AC, 50/60 Hz
---------------------------	--------------------------

— Continued on page 2 —



DIGITAL AUDIO TAPE DECK  
**SONY**®

Power consumption	35 W
Dimensions	Approx 430 × 122 × 350 mm (w/h/d) (17 × 4 <sup>7</sup> / <sub>8</sub> × 13 <sup>3</sup> / <sub>4</sub> inches)
Weight	Approx 7.5 kg

**Remote commander RM-D868 (supplied)**

Dimensions	Approx 45 × 185 × 20 mm (w/h/d) (1 <sup>13</sup> / <sub>16</sub> × 7 <sup>3</sup> / <sub>8</sub> × 1 <sup>1</sup> / <sub>16</sub> inches)
Weight	Approx 100 g (3.5 oz) incl. batteries

Supplied accessories See page 7.

Design and specifications are subject to change without notice.

**CAUTION**

Danger of explosion if battery is incorrectly replaced. Replace only with the same or equivalent type recommended by the equipment manufacturer. Discard used batteries according to manufacturer's instructions.

**ADVARSEL !**

Lithiumbatteri-Eksplosionsfare ved fejlagtig håndtering.  
Udskiftning må kun ske med batteri af samme fabrikat og type.  
Lever det brugte batteri tilbage til leverandøren.

**ADVARSEL**

Eksplosjonsfare ved feilaktig skifte av batteri.  
Benytt samme batteritype eller en tilsvarende type anbefalt av apparatfabrikanten.  
Brukte batterier kasseres i henhold til fabrikantens instruksjoner.



**VARNING**

Explosionsfara vid felaktigt batteribyte. Använd samma batterityp eller en likvärdig typ som rekommenderas av apparattillverkaren. Kassera använt batteri enligt gällande föreskrifter.

**VAROITUS**

Paristo voi räjähtää, jos se on virheellisesti asennettu. Vaihda paristo ainoastaan laitevalmistajan suosittelemaan tyyppiin. Hävitä käytetty paristo valmistajan ohjeiden mukaisesti.

**SAFETY-RELATED COMPONENT WARNING!!**

COMPONENTS IDENTIFIED BY MARK  OR DOTTED LINE WITH MARK  ON THE SCHEMATIC DIAGRAMS AND IN THE PARTS LIST ARE CRITICAL TO SAFE OPERATION. REPLACE THESE COMPONENTS WITH SONY PARTS WHOSE PART NUMBERS APPEAR AS SHOWN IN THIS MANUAL OR IN SUPPLEMENTS PUBLISHED BY SONY.

**TABLE OF CONTENTS**

Section	Title	Page
	Specifications .....	1
<b>1. GENERAL</b>		
	Location and Function of Controls .....	3
	Recording on a DAT .....	5
	Playing a DAT .....	6
<b>2. DISASSEMBLY</b>		
2-1.	Front Panel/Mechanism Deck Block .....	15
2-2.	Removal of Drum Assembly (DOU-03D-R) .....	16
2-3.	Removal of MD Board, DC-Motor U-2A (Reel) (M903) .....	16
2-4.	Removal of Loading Motor Board, DC Motor U-17 (Capstan) (M902) .....	17
2-5.	Removal of Cassette Holder Assembly .....	17
<b>3. ADJUSTMENTS</b>		
3-1.	Mechanical Adjustments .....	20
3-2.	Electrical Adjustments .....	20
<b>4. EXPLANATION OF IC TERMINALS</b>		23
<b>5. DIAGRAMS</b>		
5-1.	Block Diagram (System Control/Power Section) .....	34
	Block Diagram (Audion Section) .....	37
5-2.	Circuit Boards Location .....	40
5-3.	Printed Wiring Boards (Audio Section) .....	43
5-4.	Schematic Diagram (Audio Section) .....	47
5-5.	Schematic Diagram (Digital Section) .....	51
5-6.	Printed Wiring Boards (Digital Section) .....	55
5-7.	Printed Wiring Boards (Display Section) .....	58
5-8.	Schematic Diagram (Display Section) .....	61
5-9.	Schematic Diagram (Drum Drive Section) .....	64
5-10.	Printed Wiring Boards (Drum Drive Section) .....	67
5-11.	Printed Wiring Boards (RF AMP Section) .....	69
5-12.	Schematic Diagram (RF AMP Section) .....	71
5-13.	IC Block Diagram .....	74
<b>6. EXPLODED VIEWS</b>		
6-1.	Chassis Section .....	79
6-2.	Front Panel Section .....	80
6-3.	Cassette Compartment Section (1) .....	81
6-4.	Cassette Compartment Section (2) .....	82
6-5.	Mechanism Deck Section (1) .....	83
6-6.	Mechanism Deck Section (2) .....	84
6-7.	Mechanism Deck Section (3) .....	85
<b>7. ELECTRICAL PARTS LIST</b>		86

# SECTION 1 GENERAL

## LOCATION AND FUNCTION OF CONTROLS

### [Front Panel]

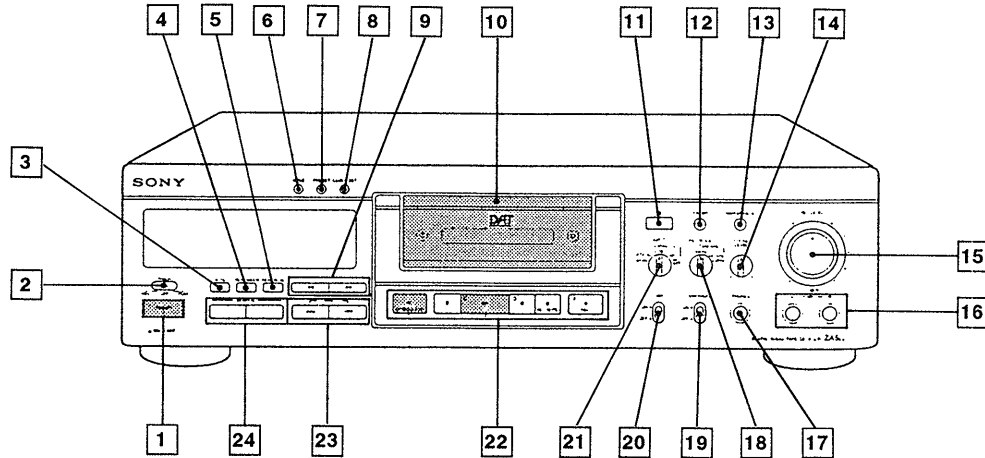

- |  |                                   |
|--|-----------------------------------|
| <b>1</b> POWER switch                    | <b>19</b> EMPHASIS switch         |
| <b>2</b> TIMER switch                    | <b>20</b> SBM* switch             |
| <b>3</b> AUTO switch                     | <b>21</b> INPUT switch            |
| <b>4</b> RENUMBER switch                 | COAXIAL } DIGITAL                 |
| <b>5</b> REHEASAL switch                 | OPTICAL }                         |
| <b>6</b> MODE switch                     | LINE } ANALOG                     |
| <b>7</b> RESET switch                    | MIC }                             |
| <b>8</b> CLOCK SET switch                | MICATT }                          |
| <b>9</b> ◀ / ▶ switch                    | <b>22</b> TAPE OPERATION buttons  |
| <b>10</b> PANEL (B)                      | △ (OPEN/CLOSE) button             |
| <b>11</b> REMOTE CONTROL sensor          | ■ (stop) button                   |
| <b>12</b> FADER switch                   | ▶ (play) button                   |
| <b>13</b> MARGIN RESET switch            | ⏸ (pause) button                  |
| <b>14</b> PHONE LEVEL control            | ○ REC MUTE (record muting) button |
| <b>15</b> REC LEVEL control              | ● REC (recording) button          |
| <b>16</b> MIC jack L/R                   | <b>23</b> ◀◀ / ▶▶ AMS** switch    |
| <b>17</b> PHONES jack (stereo mini jack) | <b>24</b> START ID switch         |
| <b>18</b> REC MODE switch                | WRITE                             |
| 48kHz } STANDARD                         | ERASE                             |
| 44.1kHz }                                |                                   |
| LONG                                     |                                   |

\*SBM=Super Bit Mapping

\*\*AMS=Automatic Music Sensor

**[Rear Panel]**

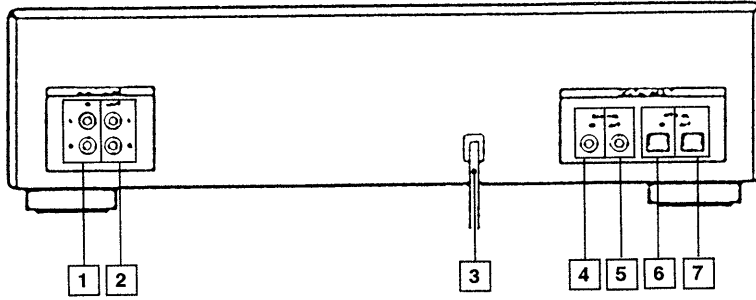

- 1 ANLOG (LINE) OUT
- 2 ANLOG (LINE) IN
- 3 AC power cord
- 4 DIGITAL COAXIAL OUT
- 5 DIGITAL COAXIAL IN
- 6 DIGITAL OPTICAL OUT
- 7 DIGITAL OPTICAL IN



# Recording on a DAT

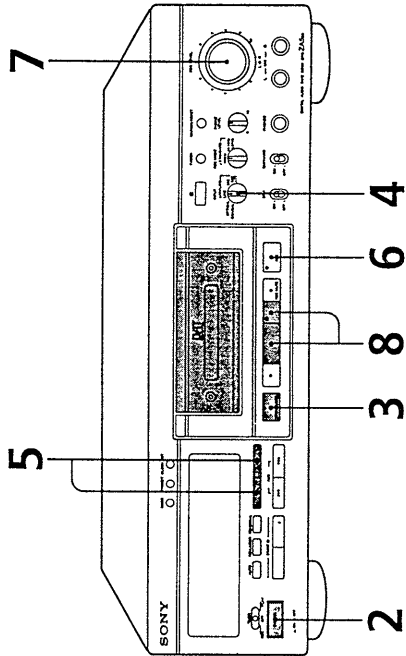

See pages 7 and 8 for hookup information.

**1** Turn on the amplifier and play the program source you want to record.

**2** Press POWER.

**3** Press OPEN/CLOSE and insert a cassette.

Window side up

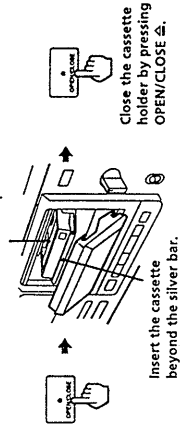

**4** Set INPUT to the corresponding input connector.

To record through	Set INPUT to
ANALOG (LINE) IN	ANALOG
MIC L/R	MIC or MIC ATT*
DIGITAL OPTICAL IN	OPTICAL
DIGITAL COAXIAL IN	COAXIAL

\* MIC ATT lets you lower (attenuate) excessively high signal levels by -20 dB when recording with microphones.

When recording with a microphone

Connect the microphones to the MIC L and R jacks located on the lower right corner of the front panel.

If "UNLOCK" appears in the display

The program source is not connected to the deck properly or is not turned on. Make sure that the program source is properly connected or turned on.

**5** Locate the position where you want to start recording.

To record from the beginning of the tape

Press to rewind the tape to its beginning.

To record from the end of the recorded portion

**1** Press to rewind the tape to its beginning.

**2** Press .

The deck locates the end of the recorded portion on the tape and stops automatically.

**6** Press REC .

The deck becomes ready to record.

**7** When recording the analog input signal, adjust the recording level with REC LEVEL.

The recommended recording level is 3. For details, refer to "Adjusting the Recording Level for Analog Recording" on page 11.

**8** Press or .

Recording starts.

**9** Start playing the program source.

When the tape reaches the end, the deck rewinds it automatically to its beginning and stops (Auto Rewind).

To

Stop recording

Pause recording

Take out the cassette

Press or .

Press the button again to resume recording.

Press OPEN/CLOSE after stopping recording.

To prevent accidental erasure  
Slide the record-protect tab to the left as shown in the illustration below.

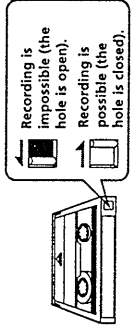

# Playing a DAT

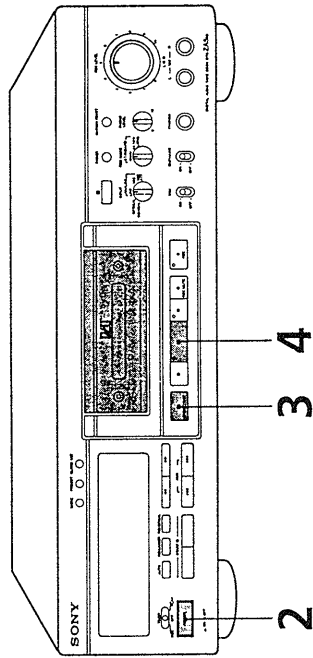

See pages 7 and 8 for hookup information.

- 1** Turn on the amplifier and set the source selector to the position for DAT.
- 2** Press POWER.
- 3** Press OPEN/CLOSE and insert a cassette.  
Window side up
- 4** Press ▶. The deck starts playing. Adjust the volume on the amplifier.

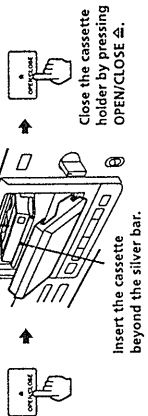

To	Press
Stop playing	■
Go to the next track	▶▶
Go to the preceding track	◀◀
Fast-forward or rewind	▶▶▶▶ or ◀◀◀◀ when the deck is stopped
Fast-forward or rewind while monitoring the sound	▶▶▶▶ or ◀◀◀◀ during playback. Release the button to resume normal playback.
Take out the cassette	OPEN/CLOSE after stopping playing

To use headphones  
Connect them to the  
PHONES Jack. Use PHONE  
LEVEL to adjust the volume.

## Unpacking

Check that you have received the following supplied items:

- Audio connecting cords (2)
- Remote commander (remote) RM-D868 (1)
- Size-AA (R6) batteries (2)
- Operating instructions (1)
- Warranty card (Canadian model only) (1)

## Inserting batteries into the remote

Insert two size-AA (R6) batteries, matching the + and - on the batteries with the markings inside the battery compartment.

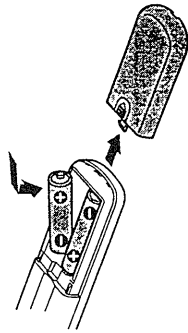

**When to replace the batteries**  
With normal use, batteries should last for about 6 months. When the remote no longer operates the deck, replace both batteries.

### Notes

- Do not leave the remote near an extremely hot or humid place.
- Do not drop any foreign matter into the remote casing, particularly when replacing the batteries.
- Do not expose the remote sensor to direct sunlight or illumination as doing so may cause malfunction.
- When not using the remote for an extended period of time, remove the batteries to avoid possible damage from battery leakage and corrosion.

## Hookup Overview

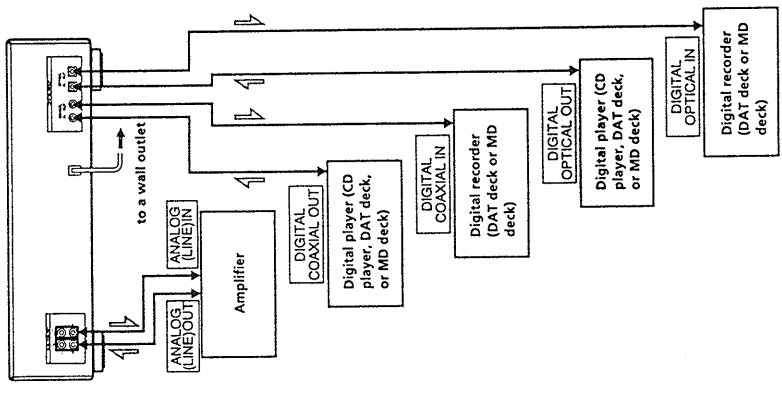

This section describes how to hook up your deck to an amplifier, CD player, MD deck, or other audio component. Be sure to turn off the power to all components before making the connections.



Signal flow

## Hookups

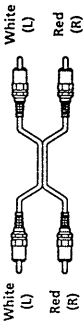
What cords will I need?

- Audio connecting cords (supplied) (2)  

- Optical cables (FOC-15 etc.) (not supplied) (2)  

- Coaxial digital connecting cable (VMC-10G etc.) (not supplied) (1)  

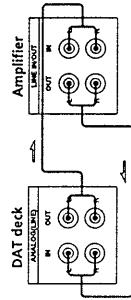
## Connecting the deck to an amplifier

Use the supplied audio connecting cords to connect the deck to an amplifier. Be sure to match each color-coded plug to the appropriate jack: red (right) to red and white (left) to white. To prevent hum and noise, be sure to make connections firmly.



## Connecting the deck to a digital audio component

Connect the component via the DIGITAL IN/OUT jacks using optical cables or coaxial digital connecting cords. In the case of optical cables, take the caps off the jacks before plugging in the cables.

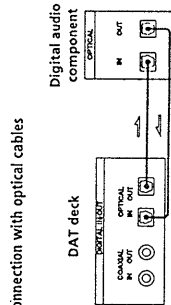

- Connection with optical cables

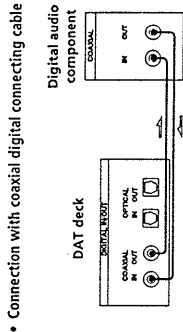

- Connection with coaxial digital connecting cable

### Note

If "PROHIBIT" appears in the display, recording through the digital jack is not possible. In this case, set the INPUT switch to ANALOG and record the program source through the ANALOG (LINE) IN jacks.

## Setting the VOLTAGE SELECTOR

(Not provided on European and Canadian models.)

Check that the VOLTAGE SELECTOR on the rear panel of the deck is set to the local power line voltage. If not, set the selector to the correct position using a screwdriver before connecting the AC power cord to a wall outlet.

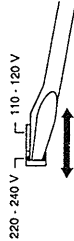

## Connecting the AC power cord

Connect the AC power cord to a wall outlet.

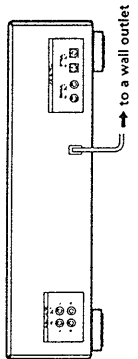

## Setting the Clock

Your deck has a built-in clock to keep track of the current date and time. Once you set the date and time, this information will be recorded on the tape along with the audio signal during recording, allowing you to check the recording date of the tape during playback at a later time.

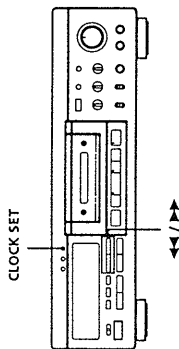

- 1 With the unit stopped, press CLOCK SET. "DATE" and the year indication start to flash.
- 2 Press ◀ or ▶ to set the year, then press CLOCK SET again. The year indication stops flashing and the month indication begins to flash.

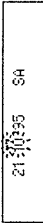

- 3 Repeat step 2 until all items have been set. After setting the seconds, press CLOCK SET to start the clock.

The days of the week are displayed as follows:

Sunday: "SU", Monday: "MO", Tuesday: "TU",  
 Wednesday: "WE", Thursday: "TH", Friday: "FR",  
 Saturday: "SA".

Time display

- Canadian model:  
 Time is displayed in a 12-hour format with midnight and noon indicated as follows:  
 Midnight: 12:00 AM  
 Noon: 12:00 PM
- Except for Canadian model:  
 Time is displayed in a 24-hour format with midnight and noon indicated as follows:  
 Midnight: 0:00  
 Noon: 12:00

## Displaying the date and time

Press PRESENT on the remote. Each time you press PRESENT, the display changes in the following order:

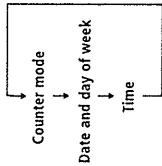

## Adjusting the clock

- 1 Press CLOCK SET repeatedly until the item you want to change begins to flash.
- 2 Press ◀ or ▶ to decrease or increase the displayed item.
- 3 Press CLOCK SET repeatedly until the seconds begin to flash, then press CLOCK SET again to start the clock.

### For more accurate time recordings

Adjust the clock once a week.

### Notes

- When you first set the clock after unpacking the deck, "----" will appear when you press the CLOCK SET button. This is normal. Set the clock according to the procedures above.
- Your deck uses a back-up battery to keep the clock running when the power is turned off. The life of the battery is approximately seven years under normal use. When the battery starts to run down, the clock will stop operating normally. When this occurs, have the battery replaced (for a fee) at your dealer or nearest Sony Service Center.

For basic recording operations, see "Recording on a DAT" on pages 4 and 5.

## Things You Should Know Before Recording

### The difference between a blank section and a sound-muted section

The deck distinguishes between two kinds of silent sections, which are respectively called a "blank section" or "sound-muted section".

**Blank section**  
This is a section on which no signal has ever been recorded.

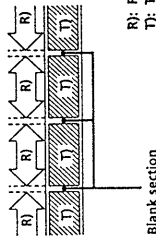

**Sound-muted section**  
This is a section on which a signal has been recorded but at a level that is not audible.

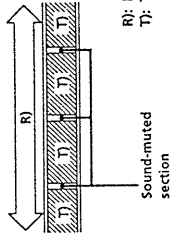

### Important

Make sure no blank sections are created while you are recording. The existence of blank sections within recorded material will make search operations using the <←/→> buttons impossible and destroy the continuity of the absolute time codes.

### Absolute time codes

The absolute time indicates the time elapsed from the beginning of the tape. Once recorded, the absolute time codes cannot be re-written.

For accurate recording of absolute time codes

- If the tape is blank, make sure to start recording from the beginning of the tape.
- Use the Record Mute function (see page 13) to insert spaces between tracks. Do not advance the tape with ► to start recording from the middle of a tape, use the End Search function (see page 11) to locate the end of the recorded portion. This will prevent the creation of blank sections.

### Lead-in area

When the deck is loaded with a new cassette tape and it detects the leader tape, it automatically creates a lead-in area, as shown in the figure below. "BB" appears in the display for about 1 second at this time. The lead-in area can be inadvertently erased on another DAT deck if you press REC ● to start recording from the beginning of the tape without closing the cassette lid first. To prevent this, press OPEN/CLOSE ⇄ to close the cassette holder before you start recording.

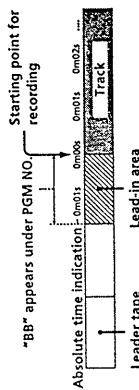

### If "EMPHASIS" appears in the display

The deck is recording a digital signal with emphasis (in the higher frequencies). The recording will also contain the same emphasis.

### If the deck is left in recording pause for more than 10 minutes

Recording pause will be released automatically, the deck will stop and "SOURCE" will appear in the display. To resume recording, press REC ●. The deck will change to recording pause.

## Adjusting the Recording Level for Analog Recording

Before you start recording through the ANALOG LINE IN or MIC jacks, set the INPUT switch to ANALOG (LINE, MIC, or MIC ATT) and adjust the recording level.

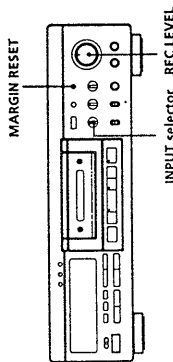

- 1 Follow steps 1 through 6 of "Recording on a DAT" on pages 4 and 5.
- 2 Play the portion of the program source with the strongest signal level.
- 3 While monitoring the sound, turn REC LEVEL to adjust the recording level so that the maximum level of the peak level meters do not enter the OVER (red) range.

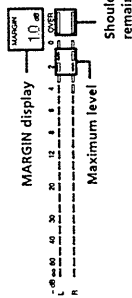

The segments of the peak level meters corresponding to the maximum signal strength remain lit longer than normal.

The MARGIN display shows the margin remaining between maximum signal strength and 0 dB. Changing each time a stronger signal is input.

If the level exceeds 0 dB

The red segments under "OVER" light up, and "0.0 dB" flashes in the display. If these segments light steadily, sound distortion may occur. To avoid this, keep the recording level between -12 dB and 0 dB.

When recording with a microphone

It may be necessary to set the INPUT selector to MIC ATT, instead of MIC, to reduce excessively high signal levels from vocals or musical instruments.

To reset the margin indication  
Press MARGIN RESET. The margin indication changes to "...dB".

4 Stop playing the program source.

5 Press II or ► to start recording, then start playing the program source.

## Locating the End of the Recorded Portion (End Search)

The deck automatically stops at the beginning of any blank section that is 9 seconds or longer. This prevents the creation of blank sections on the tape.

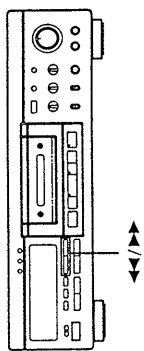

- 1 Press ◀◀ with the deck stopped. The tape rewinds to the beginning.
- 2 Press ►► The deck locates the end of the recorded portion (the beginning of the blank portion) and stops.

⚠ If you press the REC ● button while in a blank section  
The deck rewinds the tape to the beginning of the blank section and switches to record pause.

⚠ If you press ►►, ►►►, or ►►► at the beginning of a blank section  
"TAPE END" flashes in the display.

### Notes

- If you press REC ● in a blank section, "BLANK" (and "WAIT") flash in the display and the deck automatically rewinds to the beginning of the blank section.
- If you press ►► in a blank section, End Search does not work, and the deck fast-forwards to the end of the tape.
- End Search fast-forwards to the end of the tape if the tape is completely blank (i.e., brand new).

## Setting the Recording Mode

You can select between two recording modes, STANDARD and LONG when recording signals input from analog or 32 kHz digital sources. Digital signals are automatically recorded at the same sampling frequency as the input signal.

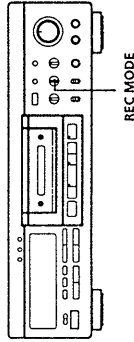

Set REC MODE to select the recording mode.

The following table shows the relationship between the REC MODE position (sampling frequency) and actual recording mode as determined by the input signal.

Input signal	REC MODE position	Recording mode
Analog	STANDARD (48 kHz)	Standard play (48 kHz)
	STANDARD (44.1 kHz)	Standard play (44.1 kHz)
	LONG	Long play (32 kHz)
Digital (32 kHz)	STANDARD (48 kHz)	Standard play (32 kHz)
	STANDARD (44.1 kHz)	Standard play (32 kHz)
	LONG	Long play (32 kHz)
Digital (44.1 kHz)	STANDARD (48 kHz)	Standard play (44.1 kHz)
	STANDARD (44.1 kHz)	Standard play (44.1 kHz)
	LONG	Standard play (44.1 kHz)
Digital (48 kHz)	STANDARD (48 kHz)	Standard play (48 kHz)
	STANDARD (44.1 kHz)	Standard play (48 kHz)
	LONG	Standard play (48 kHz)

In LONG mode (REC MODE set to LONG), you can record twice as long as in STANDARD mode on the same tape.



Using the counter in LONG mode. Since the tape running time, absolute time and remaining time are only displayed as STANDARD mode, be sure to double the time to obtain the corresponding times for LONG mode.

### Note

Do not change the INPUT or REC MODE setting while recording. This may cause an error in the "PGM TIME" display.

## Using Super Bit Mapping (SBM)

You can use the SBM function to record analog signals when the INPUT selector is set to ANALOG (LINE, MIC, or MIC ATT) and the REC MODE selector is set to STANDARD (either 48 kHz or 44.1 kHz). See "SBM (Super Bit Mapping)" on page 25 for details.

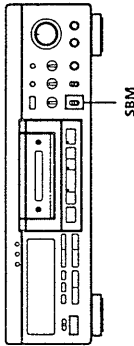

Set SBM to ON.

"SBM" appears in the display during recording with the SBM function.

To turn the SBM function off  
Set SBM to OFF.

## Using Emphasis (EMPHASIS)

By emphasizing high-bandwidth signals during analog recording (pre-emphasis), then lowering the emphasized signals during playback (de-emphasis), high-bandwidth noise is significantly reduced.

- You can use the EMPHASIS function to record analog signals when the INPUT selector is set to ANALOG (LINE, MIC, or MIC ATT).
- When recording from a digital source with the INPUT selector set to OPTICAL or COAXIAL, emphasis turns on and off automatically depending on the source signal.

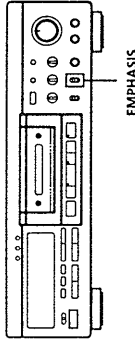

Set EMPHASIS to ON to turn on emphasis. Use the monitoring function to compare recorded sound with emphasis ON and OFF, then set the switch according to your preference. You should, however, adjust the recording level only after setting the EMPHASIS switch, since the recording level is slightly changed by the setting.

"EMPHASIS" appears in the display when recording with the Emphasis function.

To turn the Emphasis function off  
Set EMPHASIS to OFF.

## Inserting a Sound-Muted Section While Recording (Record Mute)

You can use Record Mute to insert a space of about 4 seconds between tracks. This is recommended if you plan to copy the DAT tape to an analog audio cassette tape, since the spaces will allow you to use automatic search functions to locate the beginning of each track.

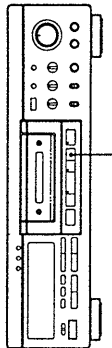

1 Press REC MUTE O where you want to insert a space while the deck is recording or in record pause.

"REC" flashes and tape transport continues for about 4 seconds, but no signal is recorded. After creating the blank space, "REC" and II light steadily in the display and the deck switches to record pause mode.

To insert a blank space longer than 4 seconds Hold down REC MUTE O as long as you want. After about 4 seconds, "REC" begins to flash faster. The MARGIN display shows how long REC MUTE O has been pressed.

When you release REC MUTE O, "REC" and II appear in the display and the deck switches to record pause mode.

2 Press II or ► to resume recording.

When recording from the beginning of a blank tape Be sure use Record Mute to create a sound-muted section. Do not advance the tape with ► or ►. This will create a blank section on the tape (see page 10).

### Note

If you do not create a sound-muted section at the beginning of a tape, you may not be able to move or erase a start ID (see page 21) that is recorded within 2 seconds from the beginning of the tape.

### Fade-in/Fade-out Recording (FADER)

You can use the fader to fade-in the beginning of a recording or fade-out the end of a recording. It's useful when you want to start or end a recording in the middle of a song.

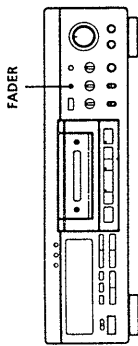

- Press FADER while in the record pause mode to start fading in.
- "FADE IN" appears in the display and the time display counts backward to "0.0s" while fading in.

#### Fading out

Press FADER while recording to start fading out. "FADE OUT" appears in the display and the time display counts backward to "0.0s" while fading out. After fading out, the deck automatically enters recording pause mode.

#### Changing the fade time

The FADE IN and FADE OUT times are factory set to 5 seconds. You can change the fade-in and/or fade-out durations from 1 to 15 seconds.

- Press FADER a few times while the deck is in stop mode to choose either "FADE IN" or "FADE OUT."
- Use ◀◀ or ▶▶ to select the respective fade duration. Each time you press ◀◀ or ▶▶ the fade duration changes in 1 second.

#### Note

The fade-in and fade-out times automatically return to 5 seconds when you turn off the power.

### Recording Using a Timer (Timer Recording)

By connecting a timer (not supplied) to the deck, you can start and stop recording operations at specified times. For further information, refer to the instructions that came with the timer.

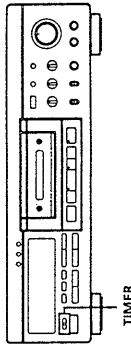

- Follow steps 1 to 7 of "Recording on a DAT" on pages 4 and 5 to prepare the deck for recording.
- To set the timer to start recording, press ■.
- To set the timer to end recording, do steps 8 and 9 of "Recording on a DAT" on page 5.
- To set the timer to both start and end recording, press ■.

#### 3 Set TIMER on the deck to REC.

- Set the timer as required.
  - When you have set the timer to start recording, the deck turns off. When the specified time arrives, the deck turns on and after about 4 seconds starts recording.
  - When you have set the timer to end recording, the deck continues recording, then when the specified time arrives, the deck stops recording and turns off.
  - When you have set the timer to both start and end recording, the deck turns off. When the starting time arrives, the deck turns on and after about 4 seconds, recording starts. When the ending time arrives, the deck stops recording and turns off.

#### 5 After using the timer, be sure to set TIMER on the deck to OFF.

#### Notes

- If TIMER switch is left at the REC position, the deck will automatically start recording the next time you turn on the deck. Be sure to set the TIMER switch to OFF before turning on the deck.
- During Timer Recording (i.e., when the TIMER switch is set to the REC position), Auto Rewind (see page 16) will not function, even if the tape ends during recording. This is to prevent previously recorded material from being recorded over.

For basic playback operations, see "Playing a DAT" on page 6.

### About the Display

You can use the display to show the following types of time information:

- absolute time
- playing time of the track
- remaining time on the tape
- tape running time
- date and time of recording
- current date and time

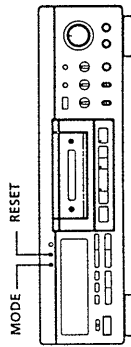

#### Changing the time display

Each time you press the MODE button, the displayed information changes as follows.

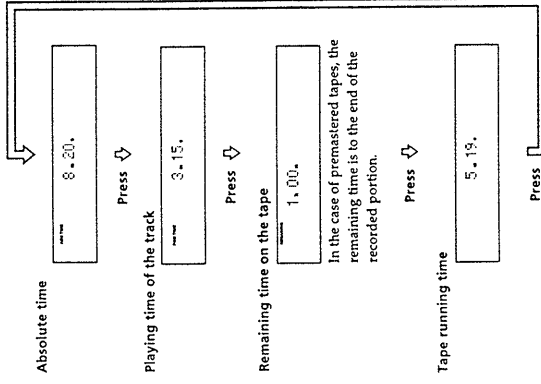

To reset the tape running time Press RESET.

#### Notes

- When playing certain types of premastered tapes, "BB" may appear momentarily in the display at the beginning of the tape.
- The playing time of the track does not appear in the following cases:
  - When you start playing from the middle of the track
  - During rewinding
- In standard-play mode, the remaining time on the tape appears about 16 seconds after you start playing.
- The displayed remaining time may vary somewhat from the actual remaining time, depending on the tape.

#### Showing the date and time of recording

During playback you can check the date, day, and time at which the current portion was recorded. If this information is not recorded on the tape, however, nothing will appear.

Press RECORDED on the remote. Each time you press RECORDED, the displayed information changes as follows.

"DATE" appears in the display when the date and day of the week or time of the recording appears.

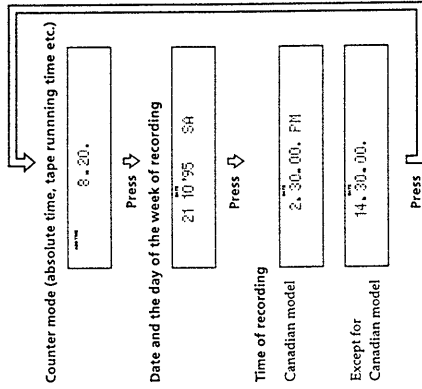

#### To show the current time

Press PRESENT on the remote. Each time you press the PRESENT button, the current date and day of the week or the current time appears in sequence. "DATE" appears in the display when the current date, day of the week and time appear (see "Displaying the date and time" on page 9).

#### If "EMPHASIS" appears in the display

The deck is playing an audio signal recorded with emphasis (in the higher frequencies). The deck, however, plays the signal while automatically deemphasizing it (with attenuation proportional to the degree of emphasis).

## Locating a Track (AMS\*/Direct Access [I]/Music Scan [I])

You can locate the tracks in a number of ways, but only after you have recorded start IDs on the tape (see pages 19 to 21). To use Direct Access, program numbers must be recorded on the tape (see pages 19 and 21).

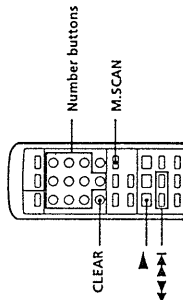
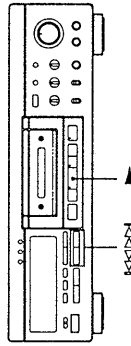

- To locate**
  - Press**
  - The beginning of the next or succeeding tracks (AMS) **▷▷** as many times as you want while playing. For example, to locate the second track ahead, press twice.
  - The beginning of the current track (AMS) **◀◀** once while playing
  - The beginning of preceding tracks (AMS) **◀◀** as many times as you want while playing. For example, to locate the second track behind, press three times.
- By specifying the program number of a track (Direct Access) [I]**
  - 1 Enter the program number of the track with the number buttons.
  - 2 Press **▶**.
- By scanning the first 8 seconds of each track (Music Scan) [I]**
  - 1 Press M.SCAN while the deck is stopped.
  - 2 Press **▶**. The deck plays the first 8 seconds of each track in succession.
  - 3 When you find the track you want, press M.SCAN. The track continues playing.

\* AMS = Automatic Music Sensor.

- ⚠** If you enter the wrong program number during Direct Access
  - If you haven't pressed **▶**, press CLEAR, then enter the correct number.
  - If you already pressed **▶** pressing CLEAR will not erase the wrong program number. Stop the deck and reenter the program number.

- ⚠** You can use Music Scan while playing a track
  - If you press the M.SCAN button while playing a track, the deck will rewind the tape to its beginning, then play the first 8 seconds of each track on the tape in succession.

- ⚠** If the deck detects a blank section of 9 seconds or more, or the end of the tape
  - The deck rewinds the tape automatically to its beginning and stops (Auto Rewind)

- ⚠** You can make the deck start playing automatically from the beginning of the tape after rewinding
  - Press **▶** while holding down **◀◀**.

## Playing Tracks Repeatedly (Repeat Play) [I]

You can play a specific track or all the tracks on the tape repeatedly.

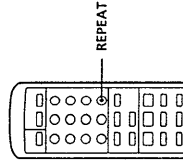

- Playing all tracks repeatedly**
  - Press REPEAT a few times while playing a track so that "REPEAT" appears in the display.
  - The deck plays all tracks 5 times, then stops automatically.
  - The deck automatically rewinds to the beginning of the tape and plays the portion from the beginning of the tape to that point if it detects any of the following during repeat play:
    - A blank section of 9 seconds or more
    - The end of the tape

- To stop playing all tracks repeatedly**
  - Press REPEAT a few times until "REPEAT" disappears.

- Note**
  - Repeat Play is canceled when you take out the cassette.

### Playing one track repeatedly

Press REPEAT a few times while playing the track you want to repeat until "REPEAT 1" appears in the display. The deck plays the current track 5 times and then stops automatically. The deck rewinds to the start ID of the current track and starts playing the portion from the start ID to that point if it detects any of the following during repeat play:

- The next start ID
- A blank section of 9 seconds or more
- The end of the tape

- To stop playing one track repeatedly**
  - Press REPEAT a few times until "REPEAT 1" disappears.

- Note**
  - Repeat Play is canceled when you take out the cassette.

## Playing Tracks in the Order You Want (RMS Play) [I]

RMS (Random Music Sensor) Play lets you specify the order in which the tracks on the tape will be played back. You can create programs containing up to 60 tracks (using program numbers 1 to 99). Before using RMS Play, however, you must first record start IDs and program numbers on the tape (see pages 19 to 21).

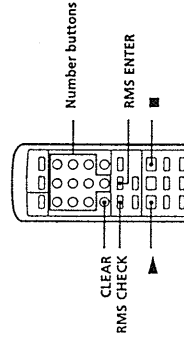

- 1** Enter the program number (1 to 99) of the track you want to play.
  - If you enter the wrong number Press CLEAR, then enter the correct number.

- 2 Press RMS ENTER.
  - STEP 1
  - STEP 2
  - STEP 3
  - STEP 4
  - STEP 5
  - STEP 6
  - STEP 7
  - STEP 8
  - STEP 9
  - STEP 10
  - STEP 11
  - STEP 12
  - STEP 13
  - STEP 14
  - STEP 15
  - STEP 16
  - STEP 17
  - STEP 18
  - STEP 19
  - STEP 20
  - STEP 21
  - STEP 22
  - STEP 23
  - STEP 24
  - STEP 25
  - STEP 26
  - STEP 27
  - STEP 28
  - STEP 29
  - STEP 30
  - STEP 31
  - STEP 32
  - STEP 33
  - STEP 34
  - STEP 35
  - STEP 36
  - STEP 37
  - STEP 38
  - STEP 39
  - STEP 40
  - STEP 41
  - STEP 42
  - STEP 43
  - STEP 44
  - STEP 45
  - STEP 46
  - STEP 47
  - STEP 48
  - STEP 49
  - STEP 50
  - STEP 51
  - STEP 52
  - STEP 53
  - STEP 54
  - STEP 55
  - STEP 56
  - STEP 57
  - STEP 58
  - STEP 59
  - STEP 60
- 3 Repeat steps 1 and 2.
- 4 Press **▶**. The deck plays the programmed tracks in sequence.

- Checking the track order [I]**
  - You can check the order of tracks in your program by pressing RMS CHECK. Each time you press RMS CHECK, the track numbers appear in the order they were programmed.

- Note**
  - You cannot use the CLEAR button to cancel a programmed track while checking the track order.

- Adding a track to the program [I]**
  - Repeat steps 1 and 2 while the deck is stopped.

- Note**
  - You cannot add a track to a program during RMS playback.

- Canceling an entire program**
  - Press **■** a few times until "RMS" disappears.

## Fade-in/Fade-out Playback (FADER)

You can use the fader to fade-in the beginning of playback or fade-out the end of playback. It's useful when you want to record from DAT.

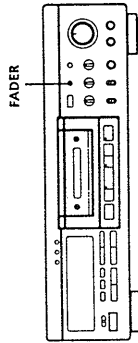

### Fading in

Press FADER while in the play/pause mode to start fading in. "FADE IN" appears in the display and the time display counts backward to "0.0s" while fading in.

### Fading out

Press FADER during playback to start fading out. "FADE OUT" appears in the display and the time display counts backward to "0.0s" while fading out. After fading out, the deck automatically enters play/pause mode.

### Changing the fade time

The FADE IN and FADE OUT times are factory set to 5 seconds. You can change the fade-in and/or fade-out durations from 1 to 15 seconds.

- 1 Press FADER a few times while the deck is in stop mode to choose either "FADE IN" or "FADE OUT."
- 2 Use ◀◀ or ▶▶ to select the respective fade duration. Each time you press ◀◀ or ▶▶ the fade duration changes in 1 second.

### Note

The fade-in and fade-out times automatically return to 5 seconds when you turn off the power.

## Playback Using a Timer (Timer Playing)

By connecting a timer (not supplied) to the deck, you can start and stop playback operations at specified times. For further information, refer to the instructions that came with the timer.

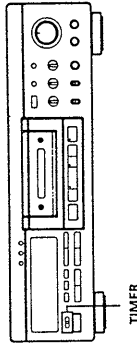

- 1 To set the timer to start playback, do steps 1 to 3 of "Playing a DAT" on page 6.
  - To set the timer to end playback, do steps 1 to 4 of "Playing a DAT" on page 6.
  - To set the timer to start and end playback, do steps 1 to 3 of "Playing a DAT" on page 6.
- 2 Set the TIMER switch on the deck to PLAY.

### 3 Set the timer as required.

- When you have set the timer to start playback, the timer will turn off the deck. When the specified time arrives, the deck turns on and starts playing after about 4 seconds.
- When you have set the timer to end playback, the deck continues to play. When the specified time arrives the deck stops playing and turns off.
- When you have set the timer to both start and end playback, the timer will turn off the deck. When the start time arrives, the deck turns on and starts playing after about 4 seconds. When the end time arrives, the deck stops playing and turns off.

- 4 After using the timer for playback set the TIMER switch on the deck to OFF.

### Note

If you leave the TIMER switch in the ON position, the deck will start playing back automatically the next time you turn on the power.

## About Sub Codes

In the DAT format, sub codes (i.e., control codes such as start IDs and program numbers) can be written on the tape along with the audio signal. These sub codes let you to use the AMS, Direct Access, and MUSIC SCAN functions (see page 16). Since the sub codes are written on the tape separately from the audio signal, they have no effect on the audio signal.

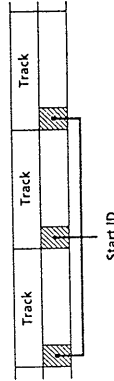

### Start IDs

Start IDs indicate the start of a track, and therefore allow you to precisely locate the position of a track. The start IDs are 9 seconds long (8 seconds in long-play mode) to enable easy detection during fast-forwarding or rewinding.

### Program numbers

Program numbers serve as track numbers. They occupy the same position as start IDs and allow you to locate specific tracks easily.

### Notes

- The **■** and **■** buttons will not work when the deck is writing sub codes.
- Writing and erasing start IDs, and renumbering program numbers is not possible if the record-protect hole on the DAT cassette is open (see page 5).

## Writing Start IDs During Recording

You can write start IDs either manually or automatically anytime during recording.

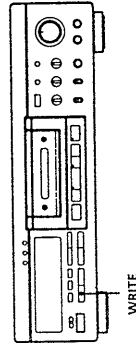

## Writing Start IDs Manually During Recording

Just press WRITE when you reach the position where you want to write the start ID. "ID WRITE" appears for a few seconds and the "START ID" indicator flashes in the display. The start ID is written on the tape at the selected position.

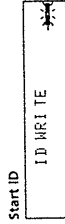

### Note

The interval between start IDs must be more than 18 seconds (36 seconds in long-play mode). If the interval is less than 18 seconds (or 36 seconds), the deck may fail to detect the second start ID during playback.

## Writing Start IDs Automatically During Recording

Start IDs are written in one of the two following ways depending on the sound source and the position of the INPUT switch. Program numbers are also written in the same position automatically.

- When recording a CD or DAT, with the INPUT switch set to OPTICAL or COAXIAL: Start IDs are written automatically whenever a new track is detected. However, start IDs are not written for tracks less than 18 seconds long.
  - When recording non-CD or DAT sources, or recording with the INPUT switch set to ANALOG: When "AUTO" is lit in the display, start IDs and program numbers are written whenever the input signal rises above a given level after remaining at a muted or low level for 3 seconds or more.
- Do the following if "AUTO" is not lit in the display.

- 1 Do steps 1 to 7 of "Recording on a DAT" on pages 4 and 5 to prepare the deck for recording.
- 2 Press AUTO so that "AUTO" appears in the display.
- 3 If you want to record from the end of a previously recorded portion, press ▶▶. The deck stops automatically at the beginning of the blank portion (End Search) and the program number following the program number of the last recorded track appears in the display. (i.e., if the last recorded track was 5, the AUTO function will display program number 6).

(Continued)



If you want to specify another program number use the number buttons to enter the program number you desire. If you are recording from the beginning of a blank tape, the first start ID is assigned program number "1."

If you forget program numbering at this time you can add them later, see "Renumbering Program Numbers Automatically (RENUMBER)" on page 21.

- Press **II** or **▶** to start recording, then start playing the program source. Start IDs (and program numbers) are written on the tape automatically during recording. "ID WRITE" appears for a few seconds whenever a start ID (and program number) is being written.

When recording from a CD player Start recording on your deck first, then press the **▶** PLAY button on the CD player while it is stopped. If you place your deck into recording pause and the CD into play pause before you start recording, the start ID and program number of the first track on the CD may not be correctly written to the tape.

**Note**  
During AUTO start ID writing, the positioning of some start IDs may be inaccurately or inappropriately positioned away from the beginning of the track. If this happens, you can reposition or erase the start IDs later (see "Accurate Positioning of Start IDs (Rehearsal)" on this page and "Erasing Start IDs" on page 21).

## Writing Start IDs During Playback

You can write start IDs in the position you want during playback.

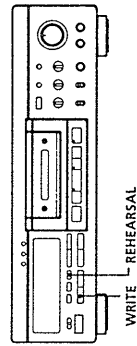

Press WRITE during playback when you reach the position where you want to write the start ID. "ID WRITE" appears for a few seconds and the "START ID" indicator flashes in the display. The start ID is written on the tape at the selected position. See the following steps for more accurate positioning of start IDs.

## Accurate Positioning of Start IDs (Rehearsal)

- During playback, press REHEARSAL when you reach the position where you want to write the start ID. "REHRSL" appears and "START ID" flashes in the display. Rehearsal repeats 3 seconds of the program, starting from the point you selected. The 3 second portion plays back 8 times. The remaining number of times appears to the right of "REHRSL." After 8 times, the deck stops automatically.
- Press **◀** or **▶** during rehearsal to move the beginning of the repeated portion. Each time you press **◀** or **▶**, the beginning of the repeated portion shifts back or forward in 0.3 second increments (to a maximum of 2 seconds, 4 seconds in long-play mode, in either direction).

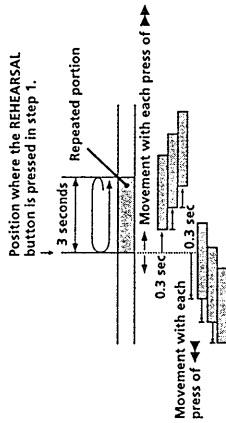

The time display shows the shift in position from when you pressed REHEARSAL.

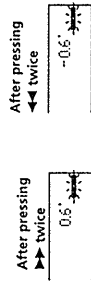

- Press WRITE when the beginning of the rehearsal is in the position you desire. "ID WRITE" appears for a few seconds and "START ID" flashes in the display. The start ID is written on the tape at the position you selected.

## Renumbering Program Numbers Automatically (RENUMBER)

Renumbering starts from the beginning of the tape and assigns a new program number to each start ID, starting with 1. Use Renumbering in the following cases:

- When you've added a start ID while playing the tape.
- When a program number is missing due to an erased start ID.
- When you wrote a program number that already exists, or when one of the start IDs has no program number.

### RENUMBER

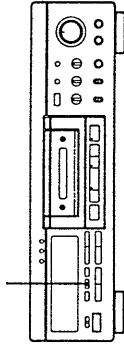

Press RENUMBER while the deck is playing or stopped. "RENUMBER" flashes in the display and the tape automatically rewinds to the beginning. The deck starts searching for start IDs from the beginning of the tape and assigns new consecutive program numbers to each start ID.

When the deck detects a start ID "START ID" flashes in the display, the deck plays the 3 second portion following the start ID, and then writes the new program number on the tape. After Renumbering is finished, the deck automatically rewinds the tape to the beginning and stops.

**Note**  
Renumbering may not function correctly when:

- A blank section exists on the tape.
- The interval between two start IDs is less than 18 seconds (36 seconds in long-play mode).
- A start ID exists within 10 seconds from the end of the tape.

## Adjusting the Position of an Existing Start ID

You can adjust the position of previously recorded start IDs.

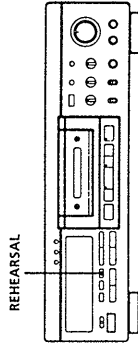

- During playback, press REHEARSAL when you reach the start ID you want to reposition. The deck rewinds to the beginning of start ID and repeats a 3-second portion.
- Follow steps 2 and 3 of "Accurate Positioning of Start IDs (Rehearsal)." You can move the start ID up to 2 seconds (4 seconds in long-play mode) in either direction from its original position.

**Note**  
Start IDs written within 10 seconds from the end of the tape may be difficult or impossible to move.

## Erasing Start IDs

You can erase any start ID.

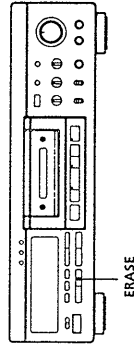

During playback, press ERASE within 9 seconds after reaching the start ID you want to erase. "ERASE" appears in the display as the deck rewinds to the beginning of the start ID, then "ID ERASE" appears as the deck erases the start ID. It takes 9 seconds to erase a start ID. Program numbers are erased together with start IDs.

### Noise-shaping filter

The SBM function uses a noise-shaping filter (see Fig. B) with a frequency response similar to that of the human ear to reduce quantizing noise within the most sensitive frequency range, and to feed back the quantizing error (that is normally lost) back to the input signal, re-integrating the low-end bit information with the high-end bit information (see Fig. B).

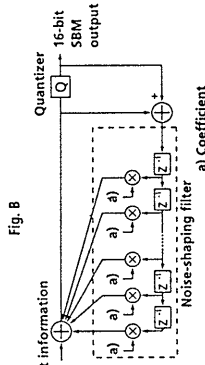

Fig. B

Fig. C shows the improvement in the quantizing noise level when the SBM switch is on (theoretical values). Given a noise level of 0 dB when the SBM switch is off, the improvement in noise level for sampling frequencies lower than 3 kHz exceeds 10 dB when the SBM is activated.

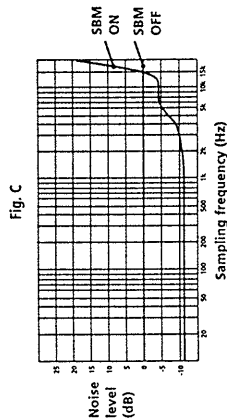

Fig. C

Since the SBM function only operates during recording, the improved sound produced by the SBM function can be enjoyed during playback regardless of the SBM switch position or the DAT deck being used.

## Guide to the Serial Copy Management System

This deck uses the Serial Copy Management System, which allows only first-generation digital copies to be made of premastered software via the deck's digital input jack. An outline of this system appears below:

1 You can record from digital program sources (CDs, premastered MDs or DATs) onto a DAT or recordable MD via digital input jack on the DAT or MD deck. You cannot, however, record from the duplicate DAT or MD onto another DAT or recordable MD via the digital input jack on the DAT or MD deck.

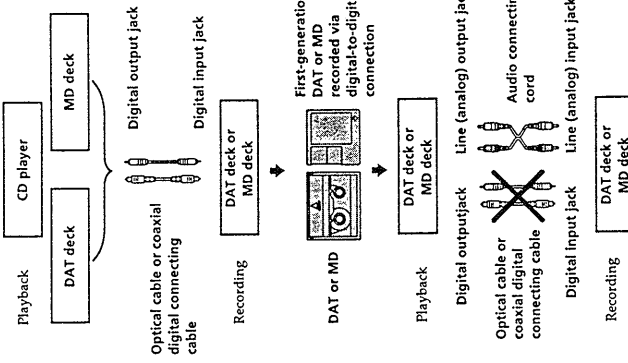

2 You can record the digital input signal of a digital satellite broadcast onto a DAT or recordable MD via the digital input jack on the DAT or MD deck which is capable of handling a sampling frequency of 32 kHz or 48 kHz. You can then record the contents of this recorded DAT or MD (first-generation) onto another DAT or recordable MD via digital input jack on the DAT or MD deck to create a second-generation digital copy. Subsequent recording from the second-generation copy onto another DAT or recordable MD is possible only through the analog input jack on the DAT or MD deck.

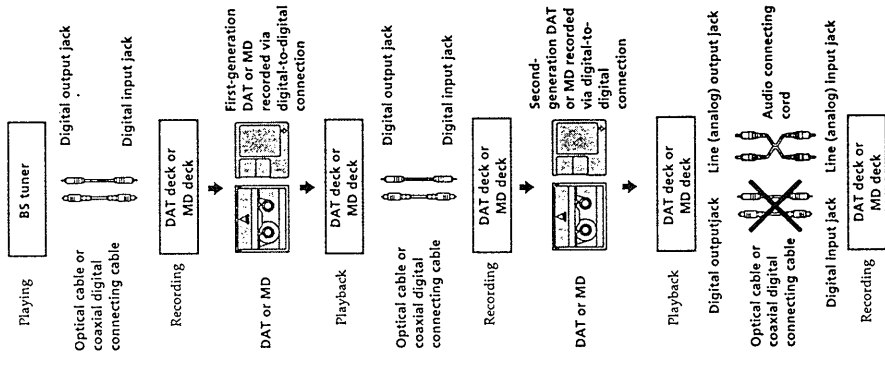

3 You can record a DAT or MD recorded via the DAT or MD deck's analog input jack onto another DAT or MD via the DAT or MD deck's digital output jack. You cannot, however, make a second-generation DAT or MD copy via the DAT or MD deck's digital output jack.

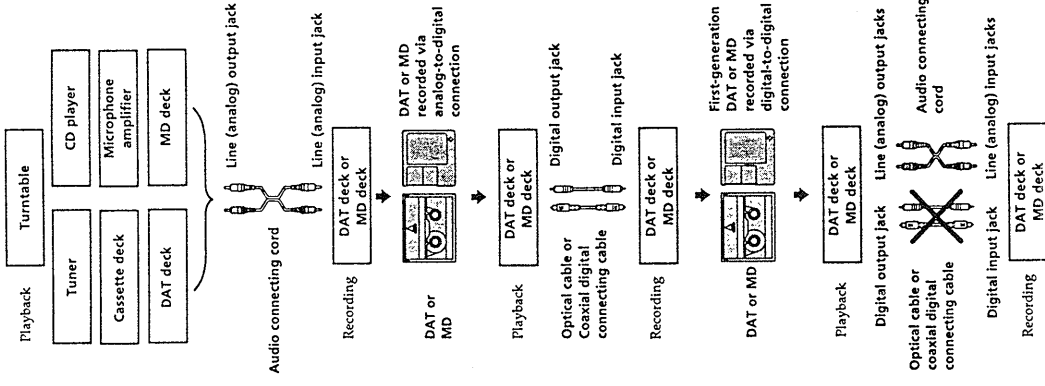

## SECTION 2 DISASSEMBLY

**Note :** Follow the disassembly procedure in the numerical order given.

### TOP, SIDE PANEL

1. Unscrew the eight top panel attachment screws (M3 × 6) and remove the panel (top).
2. Unscrew the eight side panel attachment screws (M3 × 6) and remove the panel (side).

### 2-1. FRONT PANEL/MECHANISM DECK BLOCK

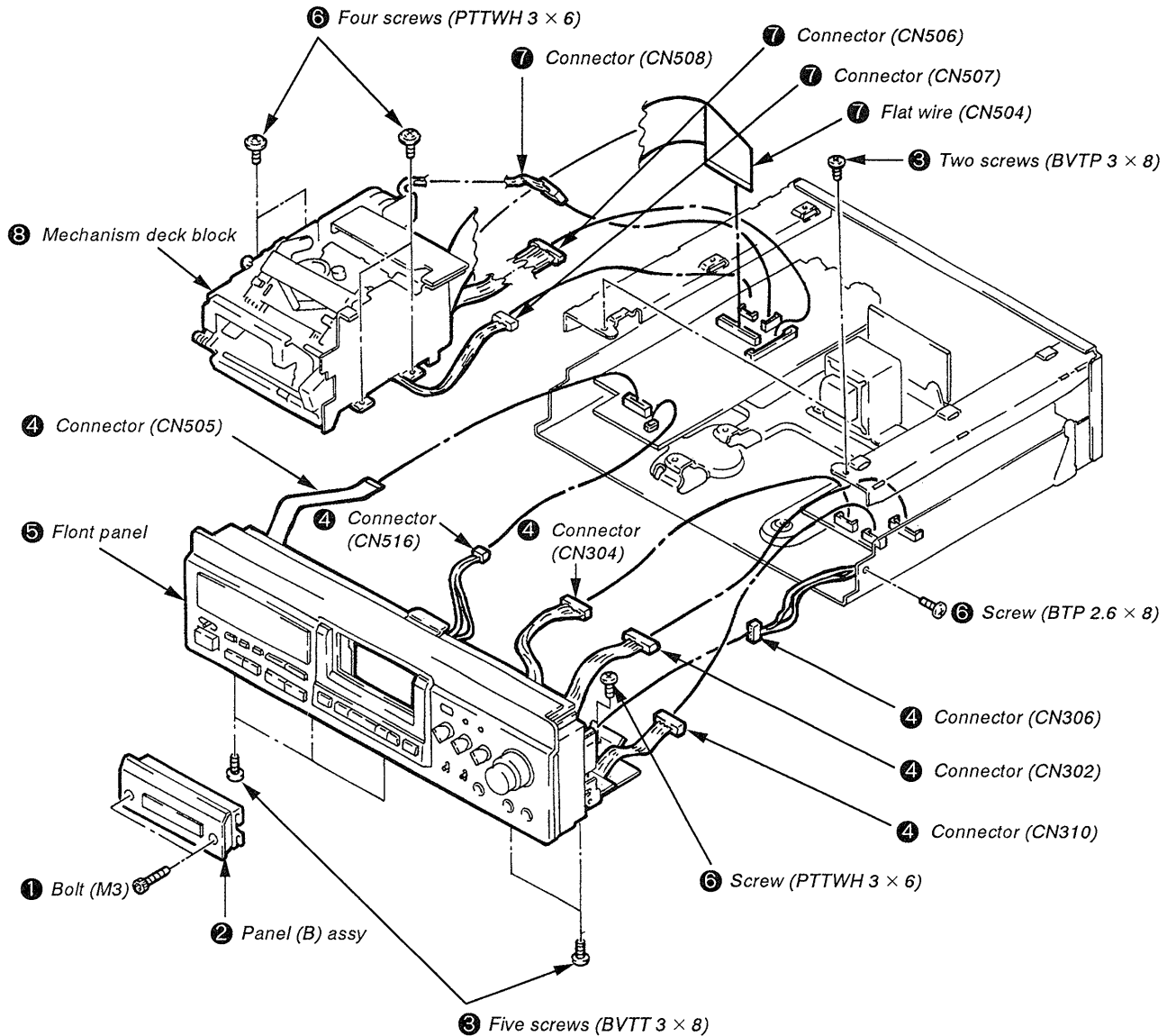

## 2-2. REMOVAL OF DRUM ASSEMBLY (DOU-03D-R)

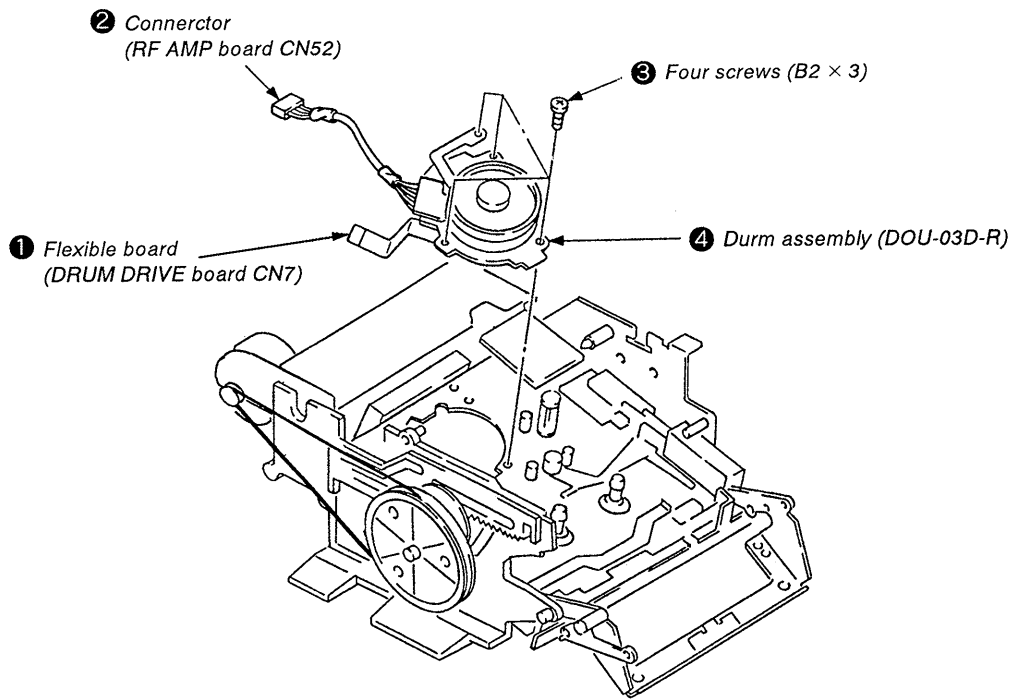

## 2-3. REMOVAL OF MD BOARD, DC-MOTOR U-2A (REEL) (M903)

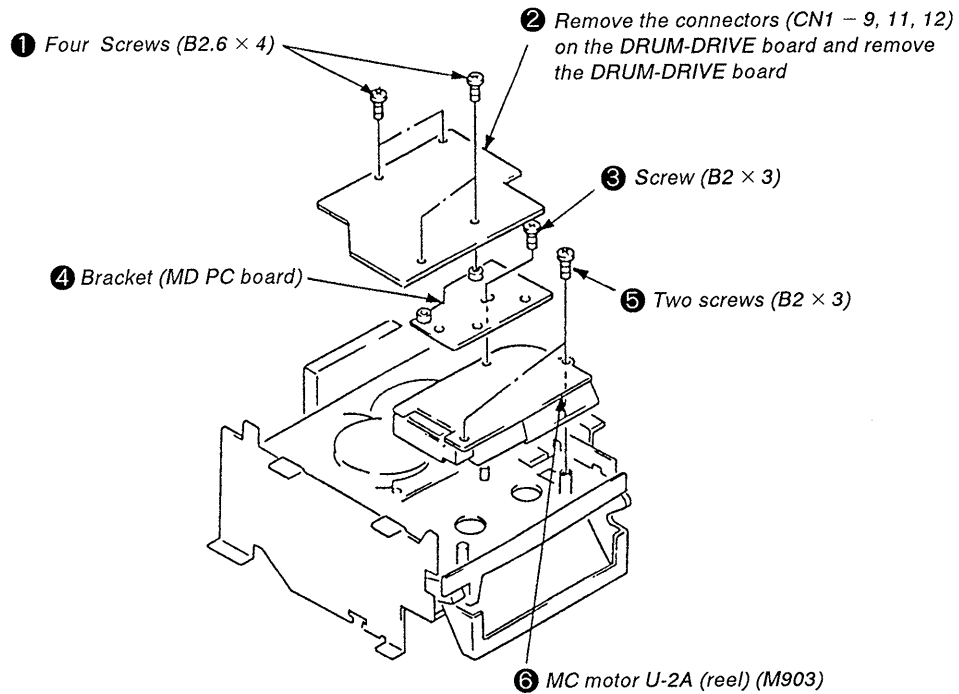

**2-4. REMOVAL OF LOADING MOTOR BOARD, DC MOTOR U-17A (CAPSTAN) (M902)**

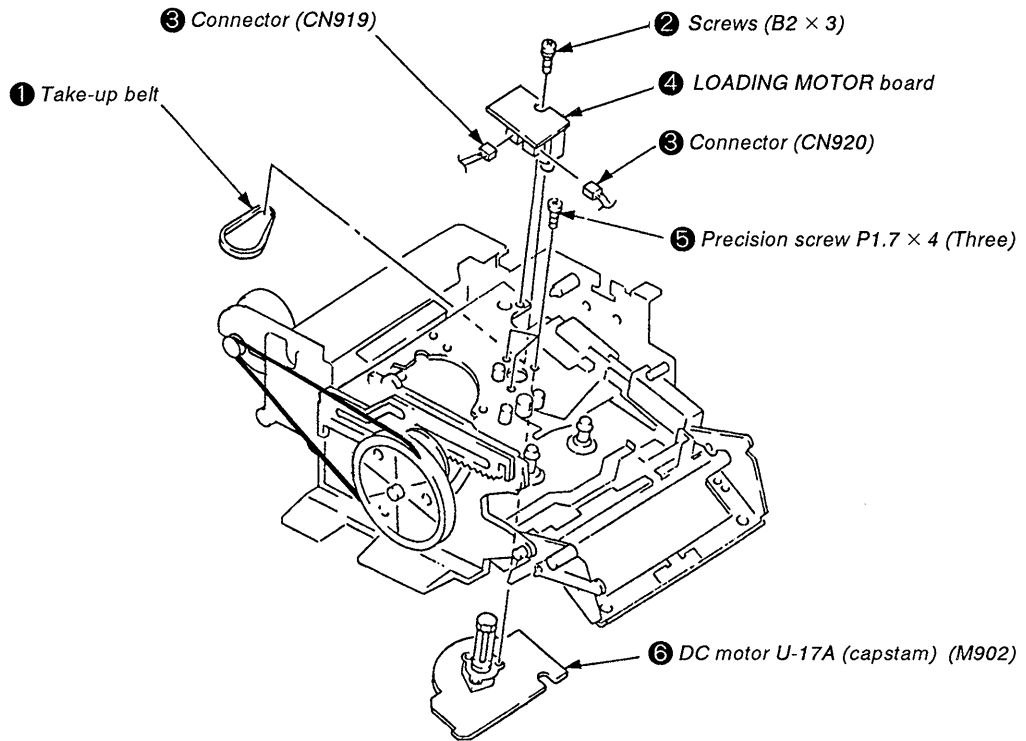

**2-5. REMOVAL OF CASSETTE HOLDER ASSEMBLY**

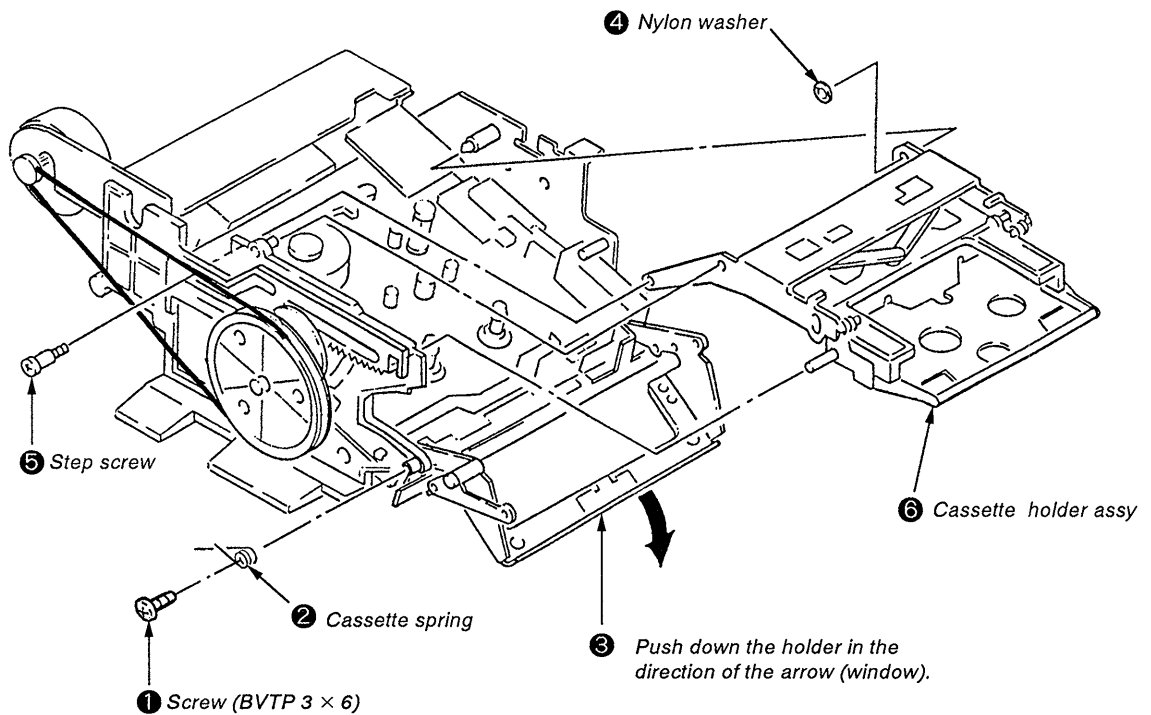

## SECTION 3 ADJUSTMENTS

### PRECAUTION

1. The adjustments are performed in the sequence that they are described.
2. The required test tapes are :
  - TY-7111 (8-909-812-00) ..... Level
  - TY-7252 (8-909-822-00) ..... Tracking
  - TY-7551 (8-909-814-00) ..... Function
  - TY-30B (8-892-358-00) ..... Blank
 The required torque meter is :  
 TW-7131 (8-909-708-71) ..... FWD

#### 3. Switch and Control Settings

REMOTE switch : OFF  
 REC MODE switch : 48k (STANDARD)  
 REC LEVEL control : Minimum  
 PHONE LEVEL control : Minimum

#### 4. Preparation of End Sensor Cassette

- (1) Push the slider locks of a cassette tape and slide the slider in the direction of the arrow.

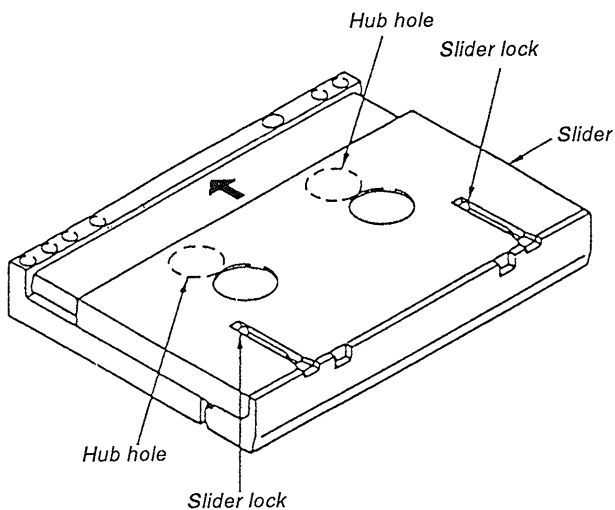

- (2) Open the cassette lid and cut tape.

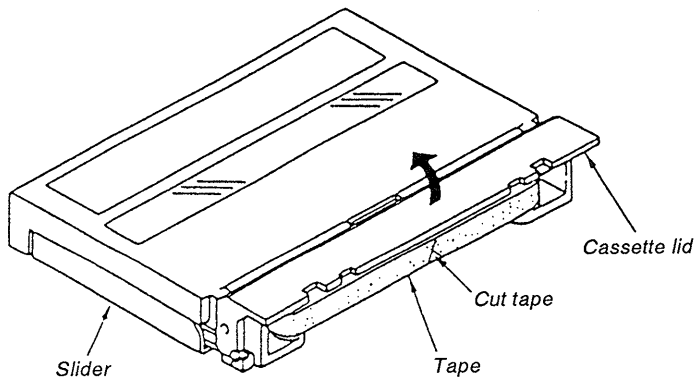

- (3) Turn the hubs take-up tape (for both T and S sides)  
 The end sensor cassette tape for end sensor adjustment is now prepared.

5. Take care never to turn RV1 and RV2 within the RF AMP board of the cassette compartment section.

6. When adjusting tape pass and each guide, as shown below, it is a good practice to remove the holder assy and use the DAT cassette holder (J-8000-002-A). This facilitates adjustment work.

- When removing and installing the casset holder assy, turn the pulley counterclockwise and set loading OUT condition for easy removal and installation.
- When adjusting, turn the pulley clockwise and turn on the CASSETTE TABLE IN switch (S1) to set loading IN condition. Then, set the test tape.

**Note :** When installing, align the arrowed portions.

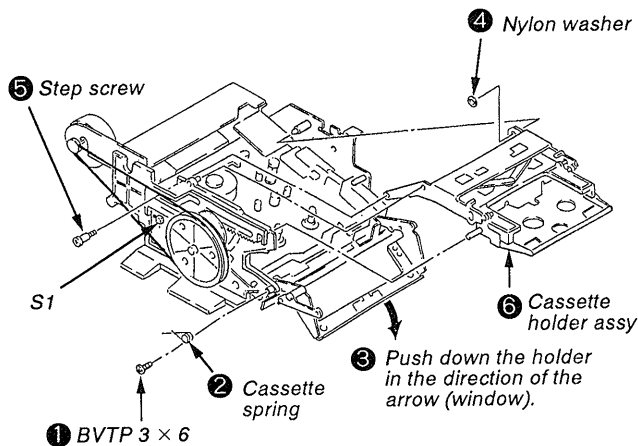

#### 7. Test Mode

- To enter the test mode, short between TP (MAIN TEST) and the GND on the DIGITAL board, then turn on the power. The meter scale within the fluorescent indicator tube (FL701) will flash.  
 Press the OPEN/CLOSE  $\blacktriangle$  key and set the test tape. (The specified tape should be used for each adjustment.)

Test Mode (Short between TP (MAIN-TEST) and GND)

- ① Have "DPG" display lit in the fluorescent indicator tube.  
 (Press the AMS  $\blacktriangleright\blacktriangleright$  key.)
  - S2, T2 and F Guide Adjustments
  - End Sensor Adjustment
  - Tape pass Fine Adjustment (  $\times 1.5$  FWD mode)
  - DPG Adjustment
- ② Have "TR" display lit in the fluorescent indicator tube.  
 (Press the  $\blacktriangleright$  key.)
  - FWD Torque Adjustments
  - FWD Back Tension Adjustments
 (Torque measurement mode)

- To release the test mode, remove the short between TP (MAIN-TEST) and GND. After necessary adjustment is completed, be sure to release the test mode

8. After adjustment is completed, perform the following checks to verify the tape speed.
- (1) Check that with the REC MODE switch set to STANDARD 48k, tape is normally recorded and played back. ( × 1)
  - (2) Check that with the REC MODE switch set to LONG, tape is normally recorded and played back. ( × 0.5)
  - (3) Check that in performing the CUE (▶ + ▶) or REVIEW (▶ + ◀) operation, “kyur kyur” sound is heard. ( × 3, × 8)

- (4) Check that after performing the FF (▶▶) or REW (◀◀) operation, the time display is appropriate. ( × 16)
- (5) Check that the AMS (▶▶, ◀◀) operation is normal.

**Adjustment Location :** Mechanism deck block

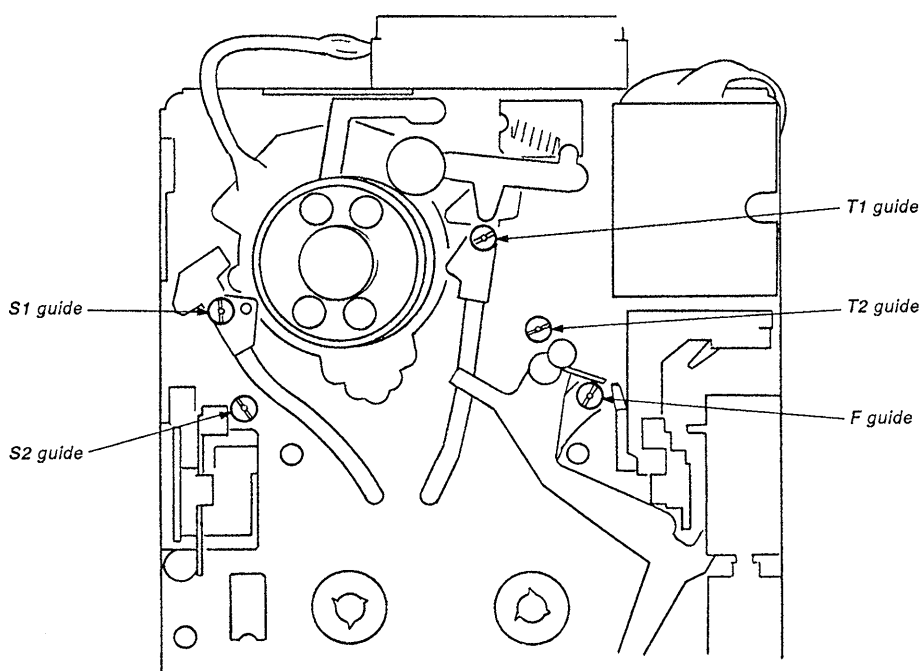

### 3-1. MECHANICAL ADJUSTMENTS

When replacing any drum related parts, after S2, T2 and F guide adjustments have been made, tape pass fine adjustment ( × 1.5 FWD mode) in Electrical adjustment should be performed.

#### S2, T2 and F Guide Adjustments

##### Adjustment Method :

1. Enter the Test Mode ① (see page 18.) and set the test tape TY-7252 (8-909-822-00).
2. Set the REC MODE switch to STANDARD 48k and press the AMS ►► key.

While in FWD mode, check that there is no curl on the upper and lower flanges of the S2, T2 and F guides.

If any curl is present, put the S2, T2 and F guide of concern back in the high position and adjust by adjusting the direction of tightening.

※ What is curl ?

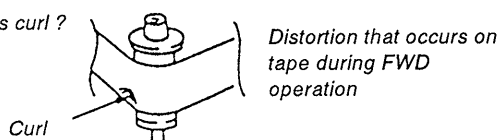

### 3-2. ELECTRICAL ADJUSTMENTS

#### End Sensor Adjustment

When removing the holder assy and when replacing the mechanism deck block, this adjustment should be performed.

Adjustment method :

1. Connect the CH-1 terminal of an oscilloscope to TP (S-END) and the CH-2 terminal to TP (T-END) on the DIGITAL board.
2. Enter the Test Mode ① (see page 18.) and set the end sensor cassette tape (see page 18.)
3. Set the STOP (■) mode.
4. Adjustment RV502 (S-END) and RV501 (T-END) on the DIGITAL board so that the respective peak to peak values of the waveforms on the oscilloscope are 1.2Vp-p.

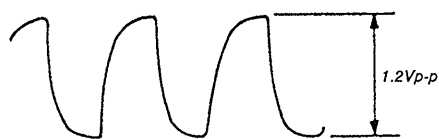

Adjustment Location : See page 22.

#### FWD Torque Adjustment

##### Adjustment method :

1. Enter the Test Mode ② (Torque Measurement Mode) (see page 18.) and set the torque meter TW-7131 (8-909-708-71).
2. Press the PLAY (►) mode.
3. Press the ►► key or ◀◀ key and adjust so that the FWD torque value (T side take-up torque) is within the range of 11 to 13 g•cm.
4. When the torque meter is circulating around, check the indicated value.

#### FWD Back Tension Adjustment

##### Adjustment method :

1. Enter the Test Mode ② (Torque Measurement Mode) (see page

18.) and set the torque meter TW-7131 (8-909-708-71)

2. Press the PLAY (►) mode.
3. Press the AMS ►► key or ◀◀ key and adjust so that the back tension (S side) is within the range of  $8.5 \pm 0.5$  g•cm.
4. When the torque meter is circulating around, check the indicated value.
5. Verify that maximum value is less than 9.5 g•cm.

#### REV Torque Check and REV Back Tension Check

##### Check method :

1. After FWD torque adjustment and FWD back tension adjustment are Completed, press the PLAY (►) key again and set REV (◀) mode.
2. Check that the REV torque value is within the range of 13.5 to 17.5 g•cm and that the REV back tension value is within the range of 7.5 to 11.5 g•cm.

#### Tape pass Fine Adjustment ( × 1.5 FWD Mode)

When replacing any drum related parts, be sure to perform this adjustment.

##### Adjustment method :

1. Connect the CH-1 terminal of an oscilloscope to TP (RF) and the CH-2 terminal to TP (SWP) on the DIGITAL board.
2. Enter the Test Mode ① (see page 18.) and set the test tape TY-7252 (8-909-822-00).
3. Press the AMS (►►) key.

Role of each switch in test mode

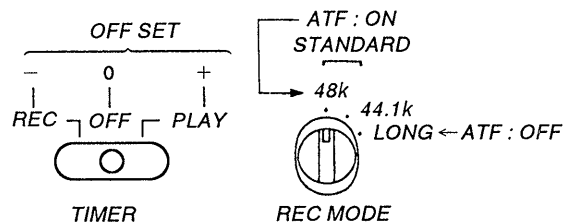

4. Put REC MODE switch to the LONG (ATF : OFF) position and put the REMOTE switch to either the WIRED or WIRELESS position (OFFSET : - or +), fine adjust both the S1 guide and T1 guide so that the RF signal waveform of the oscilloscope repeatedly contracts and expands in vertical directions as it has the same shape.

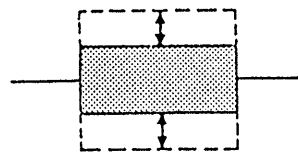

\*Adjust the direction of tightening to complete this adjustment. If there is curl on any of the upper and lower flanges of the S2, T2 and F guides, adjust the guide of concern.



5. Put the REC MODE switch to the STANDARD 48k (ATF : ON) position and put the REMOTE switch to either the WIRELESS position (OFFSET : - or + ), then check the RF signal waveform.

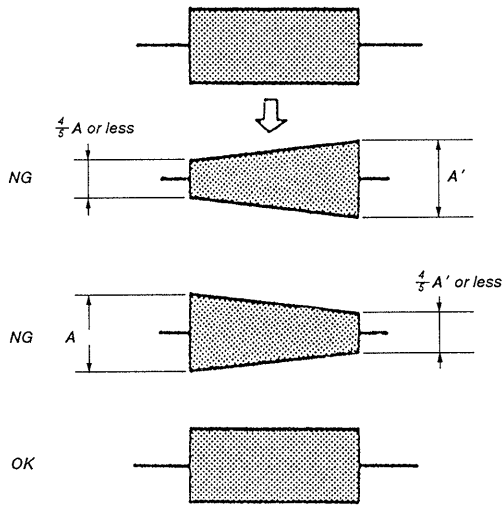

6. Put the REC MODE switch to the STANDARD 48k (ATF : ON) position and put the REMOTE switch to the OFF position (OFFSET : 0), then check the RF signal waveform.
- (1) Verify that the peak value (B) of the RF signal waveform is 60mV or more.
  - (2) Verify that the flat position of the RF signal waveform has undershoots of 10% or less.

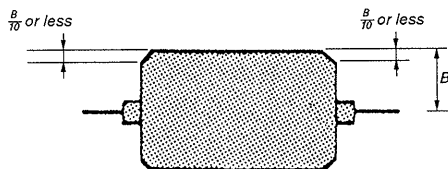

If any of the specified values are not satisfied, repeat items 3 to 6.

**Adjustment Location :** See page 22.

### PG Adjustment

When replacing any drum related parts, be sure to perform this adjustment.

#### Adjustment method :

1. Connect the CH-1 terminal of an oscilloscope to TP (RF) and the CH-2 terminal to TP (SWP) on the DIGITAL board.
2. Enter the Test Mode ① (see page 18.) and set the test tape TY-7252 (8-909-822-00)
3. Put the REC MODE switch to the STANDARD 48k (ATF : ON) position and put the REMOTE switch to the OFF position (OFFSET : 0).
4. Press the AMS (▶▶) key.
5. Press the PLAY (▶) key.

6. "DPG OK" is displayed in the fluorescent indicator tube. Check that there is a difference of  $650 \pm 15 \mu\text{sec}$  between the oscilloscope's SWP signal and the RF signal.

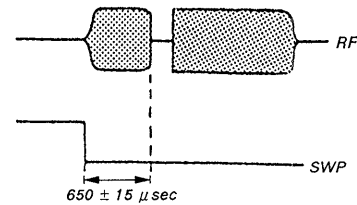

**Adjustment Location :** See page 22.

### CHECK AND REPLACEMENT FOR DATE FUNCTION

#### Clock IC Back-up Check

- When replacing the lithium battery (BATT501) or replacing any of the clock IC (IC518) and peripheral parts, the clock will be reset.

(The DATE display will be 「'-- -- --」 「--h--m--s」 even when the 「PRESENT」 button is pushed.)

Perform the back-up check by the following procedure.

- (1) Connect a DC voltmeter between the DIGITAL board's TP (BATT +) as (+) side on the TP (BATT -) as (-) side.
- (2) With the POWER switch of the set OFF, check that the voltage (1) is less than +20mV.  
(If the measured value is more than +20mV, inspect the IC518 and peripheral parts and replace as needed)
- (3) With the POWER switch of the set ON, check that the voltage (1) is less than 0mV (minus indication), (If plus indications, inspect the D510 and peripheral parts and replace as needed.)
- (4) When these voltages are normal, set the clock to the current date and time according to the instruction manual.  
(year/month/day/day of week/hours/minutes/seconds)\*
- (5) After the clock is set in item (4), turn off the POWER switch once and in several seconds, turn on the power again and make sure that the clock is operating.

**Adjustment Location :** See page 22.

### Replacement of Back-up Battery

The back-up battery for clock is designed to serve for more than seven years under normal service conditions (room temperature and ordinary humidity).

When replacing the battery, take note of the following :

- Perform the above “Clock IC Back-up Check” and remedy the cause of battery consumption.
- The open voltage of the battery as removed is 3.0V or more when it is new. If this voltage is 2.0V or less, then battery is fully consumed and needs to be replaced.
- After the battery is replaced, perform the “Clock IC Back-up Check” again and set the clock.
- The coin type lithium battery (CR2032) is used for replacement.

\* For description of the clock setting, see page 7.

### Adjustment and Check Location :

DIGITAL board – component side –

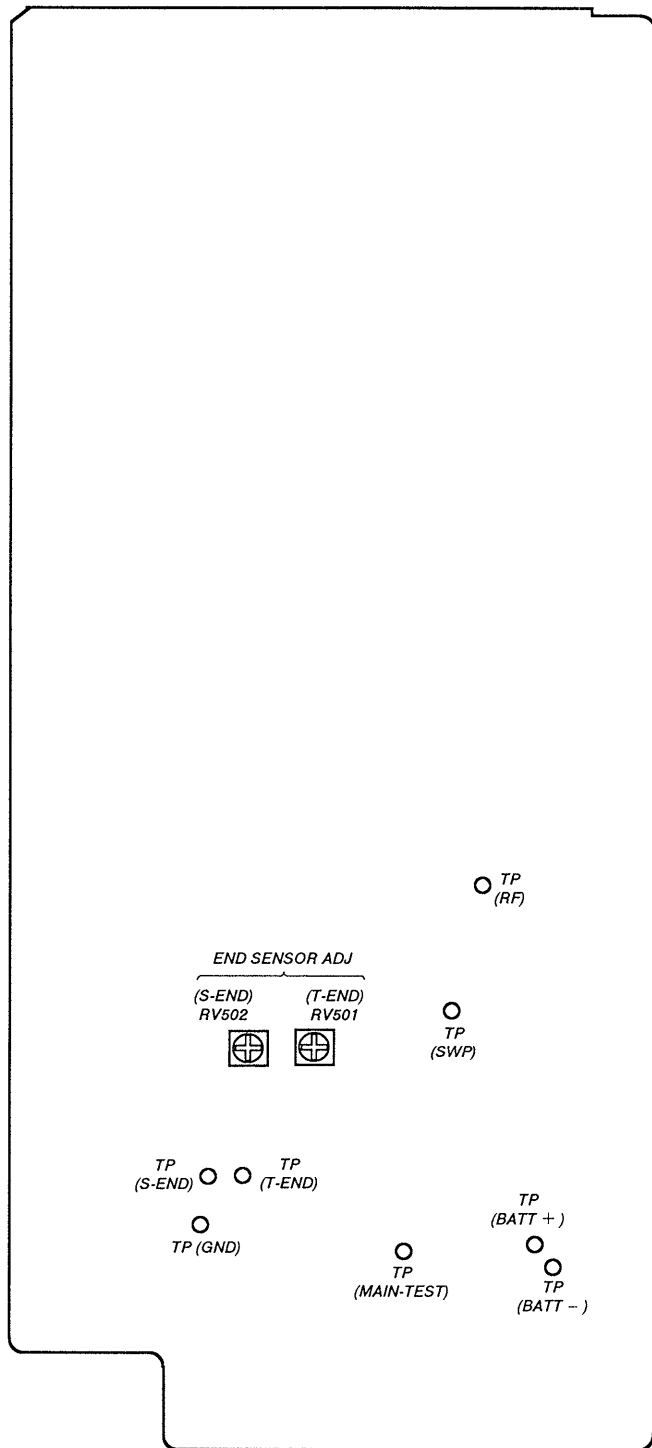

## SECTION 4 EXPLANATION OF IC TERMINALS

### IC501 (CXP87532-017Q) Main Microcomputer

Pin No.	Pin name	I/O	Description
1	SBM-ON	O	SBM digital filter ON/OFF control.
2	LCF-ON	O	Not used. (OPEN)
3	OBIT-SEL	O	Not used. (OPEN)
4	NC	–	Not used. (OPEN)
5	NC	–	Not used. (OPEN)
6	PRE-EMPH	O	PRE emphasis ON/OFF control. H : ON, L : OFF
7	AUSO	O	Serial data output.
8	AUSC	O	Serial clock output.
9	VCO-EN	O	VCO enable output. H : Digital in rec
10	XOPT/COA	O	Coaxial/Optical selector. 0 : Coaxial, 1: Optical
11	XADLD	O	Latch to digital filter for A/D converter.
12	XDALD	O	Latch to digital filter for D/A converter.
13	FADE-WE	O	Write enable to FADE IC (YM3412B).
14	FADE-RST	O	Fader reset signal output.
15	XANA/DIG	O	Analog/Digital selector. L : Analog, H : Digital
16	XREC/PB	O	Record/Playback selector. L : Record, H : Playback
17	XREPRO	O	Repro/Input selector. L : Repro, H : Input
18	MIC-ATT	O	MIC ATT ON/OFF control. L : OFF, H : ON
19	MIC-ON	O	Line/Mic ON/OFF control. L : LINE, H : MIC
20	RTC-DT	I/O	Data input/output for real time clock.
21	RTC-SC	O	Clock output for real time clock.
22	RTC-CE	O	Chip enable output for real time clock.
23	NC	–	Not used. (OPEN)
24	NC	–	Not used. (OPEN)
25	NC	–	Not used. (OPEN)
26	NC	–	Not used. (OPEN)
27	NC	–	Not used. (OPEN)
28	FS48	O	Crystal vibrator identification.
29	FS44	O	Crystal vibrator identification.
30	FS32	O	Crystal vibrator identification.
31	XLM	O	Line mute terminal. L : Mute
32	NC	–	Not used. (OPEN)
33	SLV-MUT	O	Mute output for CXD2605Q (IC503). H : ACT
34	XSLV-SEL	O	Chip select slave for CXD2605Q (IC503). L : ACT
35	AF3	I	AF mode identification.
36	AF2	I	AF mode identification.
37	AF1	I	AF mode identification.
38	AF0	I	AF mode identification.
39	MP	–	Not used. (Connected to GND)
40	XRST	I	System reset terminal.

Pin No.	Pin name	I/O	Description
41	V <sub>SS</sub>	–	Power supply (GND)
42	XTAL	O	Not used. (OPEN)
43	EXTAL	I	System clock input terminal. (9.408MHz)
44	XDISP-REQ	O	Data communications reset output to display $\mu$ COM (IC701).
45	NC	–	Not used. (OPEN)
46	XMECH-REQ	O	Data communications request output to mech $\mu$ COM (IC701).
47	NC	–	Not used. (OPEN)
48	XDISP-ACK	I	Acknowledge input from display $\mu$ COM (IC701). L : ACT
49	DM-DI	I	Serial data input from display & mecha $\mu$ COM.
50	DM-DO	O	Serial data output to display & mecha $\mu$ COM .
51	DM-CK	O	Serial clock output to display & mecha $\mu$ COM.
52	XSBSY	I	SUB SYNC input from CXD2605Q (IC503).
53	SR-DTI	I	S data input terminal.
54	SR-DTO	O	S data output terminal.
55	SR-CK	O	Serial clock output for CXD2605Q (IC503).
56	AV <sub>SS</sub>	–	Power supply for A/D converter. (GND)
57	AVREF	–	Reference voltage for A/D converter.
58	AV <sub>DD</sub>	–	Power supply for A/D converter. (+5V)
59	XMECH-BSY	I	Busy signal input from mecha $\mu$ COM (IC502).
60	FOOT-SW1	I	Foot switch input 1.
61	FOOT-SW0	I	Foot switch input 0.
62	MODE1	I	Model identification 1.
63	MODE0	I	Model identification 0.
64	X24/12	I	Real time clock indentification. H : 12, L : 24
65	DATE-ODR	I	Data display. H : Year, Month : data
66	PRL-REM	I	Parall remote key input terminal. (not used)
67	X4HEAD	I	HEAD DET. H : 2 Head, L : 4 Head
68	XPRODIO	I	Consumer/Pro use DET. L : Pro use, H : Consumer
69	XFADER	I	FADER DET. H : without Fader, L : With Fader
70	MUT-MONIT	I	Monitor mute. H : mute ON
71	XAES/COA	I	Digital input/output DET. H : COAXIAL, O : AES/EBU
72	XCNT-S	I	Wired sircs input. L : ACT
73	MOD03	I	Model identification 3.
74	MOD02	I	Model identification 2
75	LED1	O	LED 1 drive. (not used)
76	LED0	O	LED 0 drive. (not used)
77	NC	–	Not used. (OPEN)
78	NC	–	Not used. (OPEN)
79	NC	–	Not used. (OPEN)
80	ERRO	O	Error output. (not used)

Pin No.	Pin name	I/O	Description
81	NC	—	Not used. (OPEN)
82	NC	—	Not used. (OPEN)
83	NC	—	Not used. (OPEN)
84	NC	—	Not used. (OPEN)
85	NC	—	Not used. (OPEN)
86	XTEST	I	Test mode terminal. L : Test mode, H : normal
87	POW-DWN	I	Power down DET. Not used (Connected +5V)
88	V <sub>SS</sub>	—	Power supply. (GND)
89	V <sub>DD</sub>	—	Power supply. (+5V)
90	V <sub>PP</sub>	—	Connected to V <sub>DD</sub> (+5V)
91	NC	—	Not used. (OPEN)
92	NC	—	Not used. (OPEN)
93	XADINT	O	A/D initialled. L : ACT
94	XDAINT	O	D/A initialled L : ACT
95	REC-DIS	O	Record disable output terminal.
96	EXSY-MUT	O	EXSY output control to CXD2605Q (IC503).
97	XMST-SEL	O	Chip select output to CXD2605Q (IC503).
98	MST-MUTE	O	Mute output for CXD2605Q (IC503).
99	NC	—	Not used. (OPEN)
100	NC	—	Not used. (OPEN)

**IC502 (CXP87532019Q) Mechanism Microcomputer**

Pin No.	Pin name	I/O	Description
1	FPM-KI	O	FWD plunger kick drive.
2	CAP-RVS	O	Capstan motor direction drive L : FWD, H : REV
3	BPM-ON	O	Break plunger ON/OFF control.
4	BPM-KI	O	Break plunger kick drive.
5	DRM-ON	O	Drum ON/OFF control.
6	NC	—	Not used. (OPEN)
7	NC	—	Not used. (OPEN)
8	NC	—	Not used. (OPEN)
9	NC	—	Not used. (OPEN)
10	NC	—	Not used. (OPEN)
11	NC	—	Not used. (OPEN)
12	NC	—	Not used. (OPEN)
13	NC	—	Not used. (OPEN)
14	NC	—	Not used. (OPEN)
15	LM-EJCT	O	Loading motor eject drive.
16	LM-LOAD	O	Loading motor load drive.
17	CM-OUT	O	Cassette motor drive.
18	CM-IN	O	Cassette motor drive.
19	XROM-CK	O	Clock output to EEPROM.
20	XROM-DT	I/O	Data input/output to EEPROM.
21	NC	—	Not used. (OPEN)
22	NC	—	Not used. (OPEN)
23	H-FIX	I	Test mode terminal. H : Normal, L : Test
24	H-FIX	I	Test mode terminal. H : Normal, L : Test
25	CAS-IN	I	Cassette tape input DET.
26	REC-EN	I	REC enable input.
27	CAS-LCK	I	Cassette motor locked DET.
28	CAS-OUT	I	Cassette motor outed DET.
29	UNLD-SW	I	Load SW DET. H : Unload position
30	LOAD-SW	I	Load SW DET. H : Stop position
31	NC	—	Not used. (OPEN)
32	NC	—	Not used. (OPEN)
33	NC	—	Not used. (OPEN)
34	NC	—	Not used. (OPEN)
35	H-FIX	I	Test mode terminal. H : Normal, L : Test mode
36	H-FIX	I	Test mode terminal. H : Normal, L : Test mode
37	H-FIX	I	Test mode terminal. H : Normal, L : Test mode
38	H-FIX	I	Test mode terminal. H : Normal, L : Test mode
39	MP	—	Not used. (connected to GND)
40	XRST	I	System reset terminal.

Pin No.	Pin name	I/O	Description
41	V <sub>SS</sub>	–	Power supply. (GND)
42	XTAL	O	System clock output. (open, in this device)
43	EXTAL	I	System clock input. (9.408MHz)
44	XMECH-BSY	O	Data communications request output to display $\mu$ COM (IC701).
45	NC	–	Not used. (OPEN)
46	TLED-ON	O	T LED drive.
47	SLED-ON	O	S LED drive.
48	XSBSY	I	SBSY input from DSP (CXD2605Q).
49	NC	–	Not used. (OPEN)
50	NC	–	Not used. (OPEN)
51	NC	–	Not used. (OPEN)
52	XMECH-REQ	I	Data communications request input from $\mu$ COM (IC501).
53	MECH-DTI	I	S data input from main $\mu$ COM (IC501).
54	MECH-DTO	O	S data output from main $\mu$ COM (IC501).
55	MECH-SCK	O	Serial clock output for Sub-code interface.
56	AV <sub>SS</sub>	–	Power supply for A/D converter. (GND)
57	AVREF	–	Reference voltage for A/D converter.
58	AV <sub>DD</sub>	–	Power supply for A/D converter. (+5V)
59	TEND	I	T side reel from end sensor.
60	SEND	I	S side reel from end sensor.
61	H-FIX	I	Not used. (connected to +5V).
62	H-FIX	I	Not used. (connected +to 5V).
63	THICK	I	Tape thick DET terminal. 1 : 13 $\mu$ , 0 : 9 $\mu$
64	SET-MODE	I	Set identification. Low : DTC-ZA5ES
65	CAS-MODE	I	Casecon identification. 1 : 45°, 0 : 20°
66	ATF-IN	I	ATF pilot signal input.
67	TFG	I	Reel FG T side.
68	SFG	I	Reel FG S side.
69	CFG	I	Capstan FG.
70	DFG	I	Drum FG.
71	DPG	I	Drum PG.
72	DREF	I	Drum reference signal input.
73	ATF-S2	I	FRC input for DPG automatic adjustment.
74	H-FIX	I	Test mode terminal. H : Normal, L : Test mode
75	NC	–	Not used. (OPEN)
76	XCAS-TST	I	Without casecon test mode. L : Test mode
77	MST-CLK	I	Master clock for hardware. (9.408MHz)
78	PBDT	I	PB data for ATF synchronous.
79	SWP	O	Swithing Pulse output.
80	AGC-PWM	O	PWM output for AGC.

Pin No.	Pin name	I/O	Description
81	T-PWM	O	PWM output for take up reel.
82	S-PWM	O	PWM output for supply reel.
83	D-PWM	O	PWM output for drum motor.
84	C-PWM	O	PWM output for capstan motor.
85	H-FIX	I	Not used. (connected to +5V).
86	XTEST	I	Test mode titminal. L : TEST MODE
87	POW-DWN	—	Power supply.(GND
88	Vss	—	Power supply. (+5V)
89	VDD	—	Power supply. (+5V)
90	VPP	—	Connected to VDD. (+5V)
91	ATF-S2	O	ATF sampling pulse output.
92	AREA	O	Not used. (OPEN)
93	NC	—	Not used. (OPEN)
94	NC	—	Not used. (OPEN)
95	NC	—	Not used. (OPEN)
96	XLP-REC	O	LP rec control. L : LP REC
97	NC	—	Not used. (OPEN)
98	NC	—	Not used. (OPEN)
99	XTLK	O	Reel motor control. L : Reel motor T-lock
100	FPM-ON	O	FWD plunger ON/OFF control.



**IC503 (CXD2605Q) Master DAT-DSP**

Pin No.	Pin name	I/O	Description
1	A8	O	External RAM address output
2	A9	O	External RAM address output
3	VDD	—	+5V
4	A10	O	External RAM address output
5	A11	O	External RAM address output
6	A12	O	External RAM address output
7	A13	O	External RAM address output
8	A14	O	External RAM address output
9	XWE	O	External RAM write enable signal output
10	XOE	O	External RAM output enable signal output
11	XEAN	O	External addressing enable signal output (not used in this set)
12	TST1	I	Test input (Fixed at "L" level.)
13	XT1O	O	X'tal oscillation circuit 1 output (18.816MHz)
14	XT1I	I	X'tal oscillation circuit 1 input (18.816MHz)
15	VSS	—	GND
16	XRST	I	Reset input. "L" for reset.
17	CLKO	O	System clock output. (The frequency is 4.9152 MHz when SELC is set "L" and 8.192MHz when SELC is set "H".) (Not used in this set.)
18	MINT	O	Control byte (1). Bit 1 : Q code decode (intercurve detection) output when "L" and BCK clock output by RX-PLL when "H". (Not used in this set.)
19	ATSY	I	ATF sync signal input
20	MCLK	O	Channel clock (fch) output (Not used in this set.)
21	DREF	O	SBSY cycled Duty 50 signal output
22	SBPM	O	Control byte (1). Bit 1 : Output of monitor signal for data transfer to and from microcomputer when "L" ("L" to permit transfer) and F256 clock output by RX-PLL when "H". (Not used in this set.)
23	EXCK	I	Input of clock for data transfer to and from main microcomputer (IC501).
24	SDSI	I	Serial data input from main microcomputer (IC501).
25	SDSO	O	Serial data output to main microcomputer (IC501).
26	SBSY	O	Output of frame sync signal for data transfer to and from main microcomputer (IC501).
27	PLRF	O	Output of PLL clock divided by 5880. (Not used in this set.)
28	CCLK	O	9.8304MHz output when SELC is "L" and 12.288MHz output when SELC is "H". (Not used in this set.)
29	MUTE	I	Mute input. Set "H" to mute, but REC monitor sound will not be muted.
30	MUTM	O	Mute monitor. "H" in muting.
31	UNLK	O	RX-PLL lock monitor signal output. "L" in locking.
32	RFCT	I	Playback RF signal control. ("L" to enable RF signal and "H" to disable RF signal.)
33	SYMN	O	RF associated C1 check result monitor signal output. (Not used in this set.)
34	SELB	I	Test pin (Fixed at "H" level.)
35	PLCK	O	Control byte (1). Bit 1 : RF-PLL clock output when "L" and F128 clock output by RX-PLL when "H" (Not used in this set.)
36	TST2	I	Test pin (Fixed at "L" level.)
37	RFDT	I	Playback RF signal input
38	XCS	I	Input of chip select signal for data transfer to and from microcomputer. "L" to permit transfer.
39	SWP	I	RF switching pulse. "L" to select A track and "H" to select B track.
40	VSS	—	GND
41	PIPC	O	Output of ATF pilot signal/discrimination signal for recording signal. "H" to output pilot signal.
42	REPB	O	REC/PB discrimination signal output. "H" for REC mode.
43	REDT	O	Recording signal output

Pin No.	Pin name	I/O	Description
44	TST4	I	Test pin (Fixed at "L" level.)
45	PDO	O	RX-PLL phase comparator output
46	SELC	I	Oscillation frequency select signal input (Fixed at "L" level in this set. )
47	MUTA	I	Mute input. "H" to mute, and REC monitor sound is also muted.
48	PLCO	I	RX-PLL's external VCO clock input (512fs reference)
49	PLVR	O	Output of phase comparator signal for RX-PLL. (2fs generated from PLL clock.) (Not used in this set.)
50	PLRF	O	Output of phase comparator signal for RX-PLL. (RX SYNC detect signal 2fs) (Not used in this set.)
51	MSSL	I	Master mode/slave mode select. "H" for master mode.
52	RX	I	Digital interface signal input
53	VDD	—	+5V
54	TX	O	Digital interface signal output
55	SELA	I	Test pin (Fixed at "L" level.)
56	EXSY	I/O	External sync signal input/output
57	EXSN	I/O	External sync signal input/output
58	F128	I/O	128fs signal/256fs signal (high speed) input/output
59	F256	O	256fs signal/512fs signal (high speed) output (Not used in this set.)
60	F512	O	512fs signal output (Not used in this set.)
61	ADLF	I	ADDT, ADDI, ADDN serial data LSB/MSB first select input. "L" for LSB first.
62	DALF	I	DADT, DADO serial data LSB/MSB first select input. "L" for LSB first.
63	XT2O	O	X'tal oscillation circuit 2 output (not used in this set)
64	XT2I	I	X'tal oscillation circuit 2 input (24.576MHz)
65	VSS	—	GND
66	XT3O	O	X'tal oscillation circuit 3 output (24.576MHz)
67	XT3I	I	X'tal oscillation circuit 3 input (24.576MHz)
68	FSEN	I	F128, BCK, LRCK input/output select input. "H" for output.
69	LR03	O	Inverted LR02 signal (Not used in this set.)
70	LR02	O	Control byte (1). Bit 1: 16BCK delayed LRCK signal when "L" and LRCK clock output by RX-PLL when "H" (Not used in this set.)
71	LR01	O	15BCK delayed LRCK signal
72	LRCK	I/O	fs/2fs (high speed) signal input/output
73	WCK	O	2fs/4fs (high speed) signal output (Not used in this set.)
74	XBCK	O	Inverted BCK signal output
75	BCK	I/O	64fs/128fs (high speed) signal input/output
76	ADDT	I	AD serial data input
77	DADT	O	DA serial data output
78	DADO	I	DIGITAL OUT audio data input
79	ADDI	O	DIGITAL IN audio data output
80	ADDN	I	DIGITAL IN audio data input
81	ERRI	I	DIGITAL OUT Validity flag data input
82	ERRF	O	DADT data's interpolation data/discrimination signal output. "H" for interpolation data.
83	MNTG	O	"H" output indicates that error correction status monitor data is being output to D7 to D0. (Not used in this set.)
84	D7	I/O	External RAM data input/output (MSB)
85	D6	I/O	External RAM data input/output
86	D5	I/O	External RAM data input/output
87	D4	I/O	External RAM data input/output
88	D3	I/O	External RAM data input/output
89	D2	I/O	External RAM data input/output
90	VSS	—	GND

Pin No.	Pin name	I/O	Description
91	D1	I/O	External RAM data input/output
92	D0	I/O	External RAM data input/output (LSB)
93	A00	O	External RAM address output
94	A01	O	External RAM address output
95	A02	O	External RAM address output
96	A03	O	External RAM address output
97	A04	O	External RAM address output
98	A05	O	External RAM address output
99	A06	O	External RAM address output
100	A07	O	External RAM address output

**IC701 (CXP82316-058Q)**

Pin No.	Pin name	I/O	Description
1	H	I	Not used. (H level)
2	RMC	I	Remocon receiver signal input.
3	TEST	I	Test mode terminal.
4	A1 METER	O	Address 1 output to digital meter IC (MSM6338).
5	A2 METER	O	Address 0 output to digital meter IC (MSM6338).
6	M MUT	I	Input mute for level meter.
7	ACK	O	Acknowledge output to IC501 (CXP87532).
8	SC	I	Serial clock input from IC501 (CXP87532).
9	SI	I	Serial data output from IC501 (CXP87532).
10	SO	O	Serial data output to IC501 (CXP87532).
11	CS METER	O	CS output to meter IC (MSM6338).
12	RD METER	O	RD output to meter IC (MSM6338).
13	WR METER	O	WR output to meter IC (MSM6338).
14	REM-SEL	O	SIRCS select control.
15	FWD LED	O	Play LED drive. H=Lighing
16	PAUSE LED	O	PAUSE LED drive. H=Lighing
17	REC LED	O	REC LED drive. H=Lighing
18	NC	—	Not used. (OPEN)
19	NC	—	Not used. (OPEN)
20	NC	—	Not used. (OPEN)
21	NC	—	Not used. (OPEN)
22	AD0	I	Key A/D converter analog input.
23	AD1	I	Key A/D converter analog input.
24	AD2	I	Key A/D converter analog input.
25	AD3	I	Key A/D converter analog input.
26	AD4	I	Key A/D converter analog input.
27	AD5	I	Key A/D converter analog input. (not used)
28	AD6	I	Key A/D converter analog input. (not used)
29	AD7	I	Key A/D converter analog input. (not used)
30	XRST	I	System reset terminal. (Low active)
31	EXTAL	I	System clock. (4.19MHz)
32	XTAL	O	
33	Vss	—	Power supply. (GND)
34	S0	O	FL Segment drive.
35	S1	O	FL Segment drive.
36	S2	O	FL Segment drive.
37	S3	O	FL Segment drive.
38	S4	O	FL Segment drive.
39	S5	O	FL Segment drive.
40	S6	O	FL Segment drive.

Pin No.	Pin name	I/O	Description
41	S7	O	FL Segment drive.
42	S8	O	FL Segment drive.
43	S9	O	FL Segment drive.
44	S10	O	FL Segment drive.
45	S11	O	FL Segment drive.
46	S12	O	FL Segment drive.
47	S13	O	FL Segment drive.
48	S14	O	FL Segment drive.
49	S15	O	FL Segment drive.
50	S16	O	FL Segment drive.
51	S17	O	FL Segment drive.
52	S18	O	FL Segment drive.
53	S19	O	FL Segment drive.
54	S20	O	FL Segment drive.
55	S21	O	FL Segment drive.
56	S22	O	FL Segment drive.
57	S23	O	FL Segment drive.
58	T12	O	FL Grid drive.
59	T11	O	FL Grid drive.
60	T10	O	FL Grid drive.
61	T9	O	FL Grid drive.
62	T8	O	FL Grid drive.
63	T7	O	FL Grid drive.
64	T6	O	FL Grid drive.
65	T5	O	FL Grid drive.
66	T4	O	FL Grid drive.
67	T3	O	FL Grid drive.
68	T2	O	FL Grid drive.
69	T1	O	FL Grid drive.
70	T0	O	FL Grid drive.
71	VFDP	–	VFDP display power. ( – 30V)
72	V <sub>DD</sub>	–	Power supply. (+5V)
73	NC	–	Not used. (V <sub>DD</sub> connection)
74	D0 METER	I/O	Data 0 input/output to meter IC (MSM6338)
75	D1 METER	I/O	Data 1 input/output to meter IC (MSM6338)
76	D2 METER	I/O	Data 2 input/output to meter IC (MSM6338)
77	D3 METER	I/O	Data 3 input/output to meter IC (MSM6338)
78	X 60ES	I	Not used. (GND connection)
79	REQ	I	Requesting for communication from IC501 (CXP87532).
80	X 790	I	V <sub>DD</sub> connenction, in this device.

SECTION 5  
DIAGRAMS

5-1. BLOCK DIAGRAM (SYSTEM CONTROL/POWER SECTION)

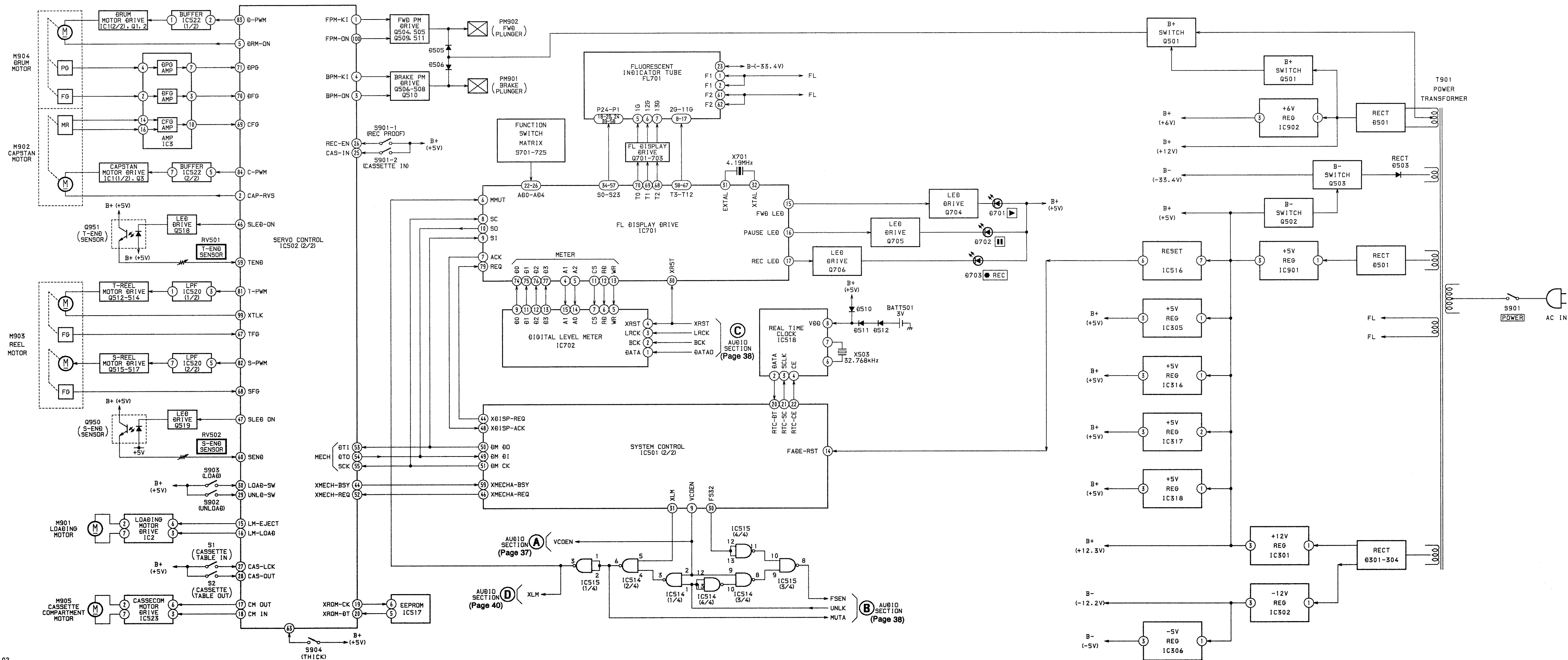

BLOCK DIAGRAM (AUDIO SECTION)

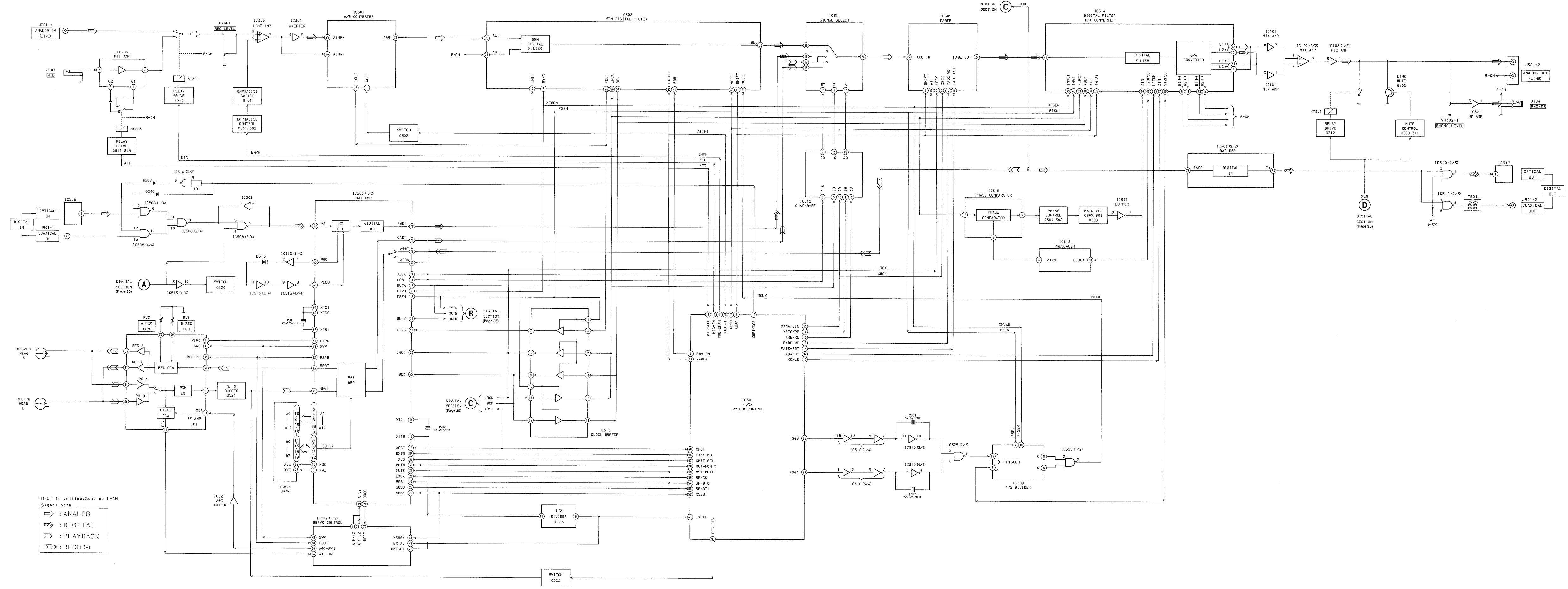

5-2. CIRCUIT BOARD LOCATION

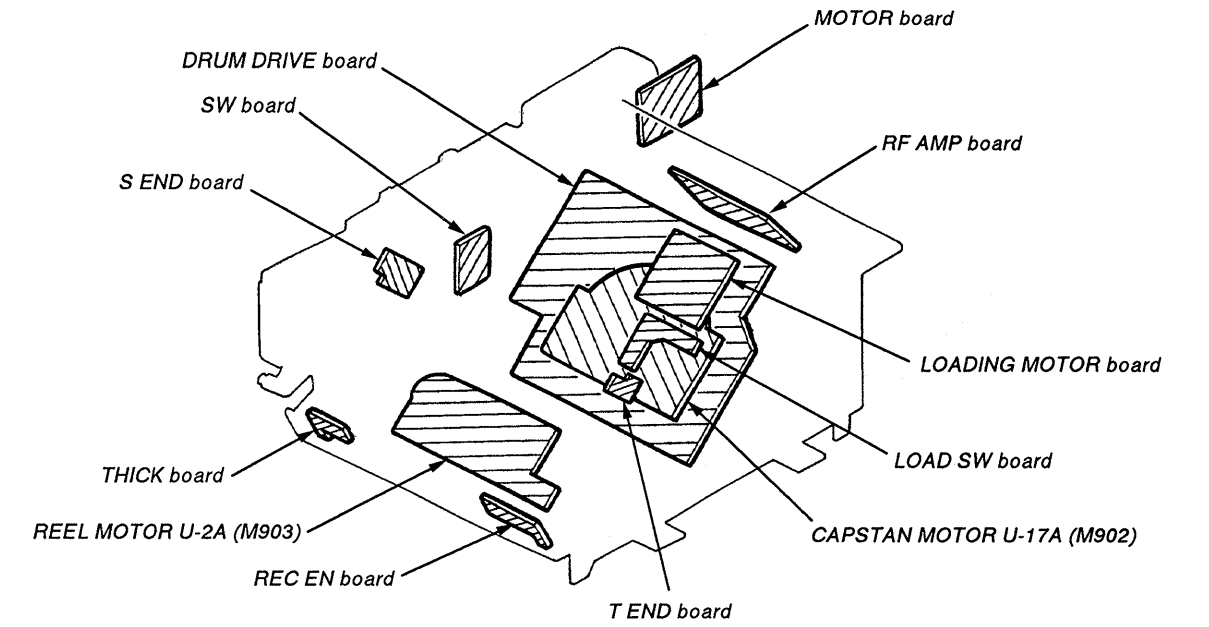
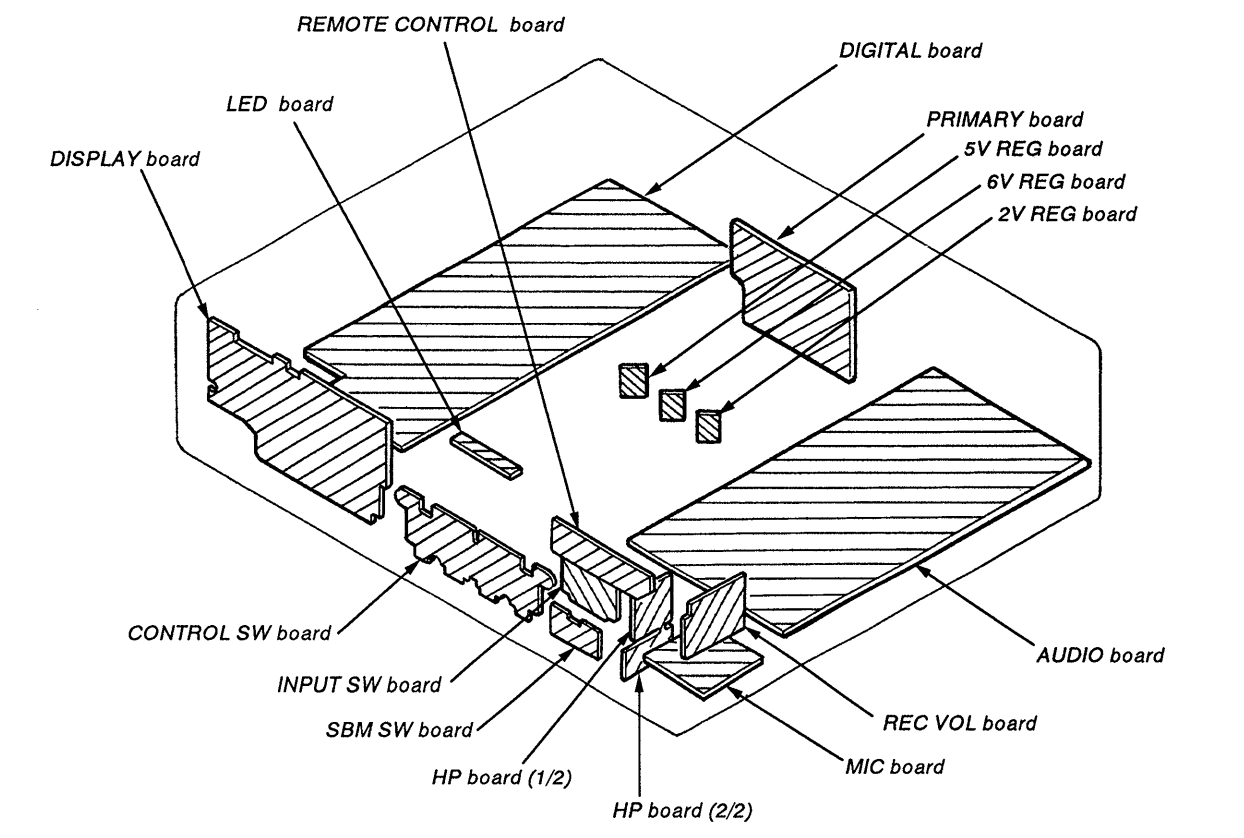



● WAVEFORMS (AUDIO SECTION)

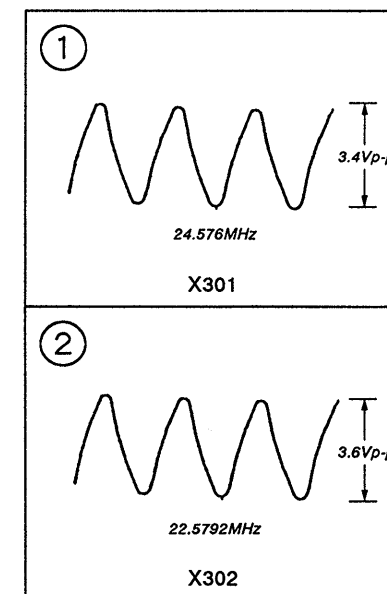

● SEMICONDUCTOR LOCATION

Ref. No.	Location	Ref. No.	Location
D101	I-12	Q310	C-17
D102	I-12	Q311	C-17
D103	I-12	Q312	C-16
D104	I-12	Q313	I-16
D201	H-12	Q314	H-16
D202	H-12	Q315	H-16
D203	H-12		
D204	H-12		
D301	C-6	IC101	F-14
D302	C-7	IC102	F-14
		IC105	H-18
D303	C-5	IC201	D-14
D304	C-5	IC202	D-14
D305	H-4		
D306	I-4	IC205	H-20
D307	E-16	IC301	F-7
		IC302	F-5
D308	E-13	IC303	H-14
D309	I-23	IC304	H-13
D313	H-6		
D314	I-6	IC305	I-12
D315	H-16	IC306	H-12
		IC307	H-10
		IC308	H-8
		IC309	I-7
Q101	I-14		
Q102	F-16	IC310	H-5
Q201	H-14	IC311	D-12
Q202	D-16	IC312	C-8
Q301	I-16	IC313	D-9
		IC314	E-9
Q302	I-16		
Q303	H-10	IC315	C-12
Q304	D-12	IC316	H-7
Q305	D-13	IC317	F-8
Q306	D-13	IC318	G-11
		IC321	F-23
Q307	G-12		
Q308	F-12		
Q309	C-17	IC325	H-6

Note : AUDIO SECTION

- All capacitors are in  $\mu$  F unless otherwise noted. pF:  $\mu$   $\mu$  F 50WV or less are not indicated except for electrolytics and tantalums.
- All resistors are in  $\Omega$  and  $\frac{1}{4}$ W or less unless otherwise specified.
- : fusible resistor.

Note : The components identified by mark or dotted line with mark are critical for safety. Replace only with part number specified.

- : B+ Line
- : B- Line
- : adjustment for repair.
- Voltage and waveforms are dc with respect to ground under no-signal (detuned) conditions.
- no mark : PLAYBACK
- ( ) : RECOED
- Voltages are taken with a VOM (Input impedance 10M  $\Omega$ ). Voltage variations may be noted due to normal production tolerances.
- Waveforms are taken with a oscilloscope. Voltage variations may be noted due to normal production tolerances.
- Circled numbers refer to waveforms.
- Signal path.
- : ANALOG

Note:

- : parts extracted from the component side.
- : Through hole.
- : Pattern on the side which is seen.
- : Pattern of the rear side.

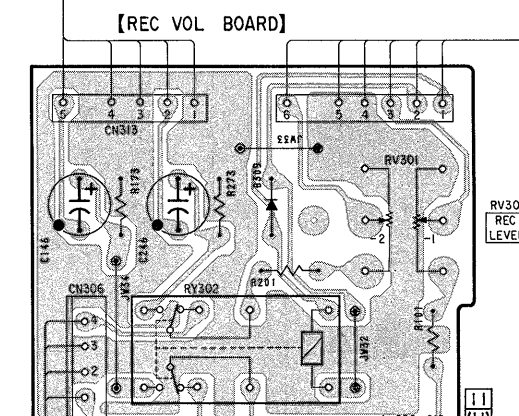
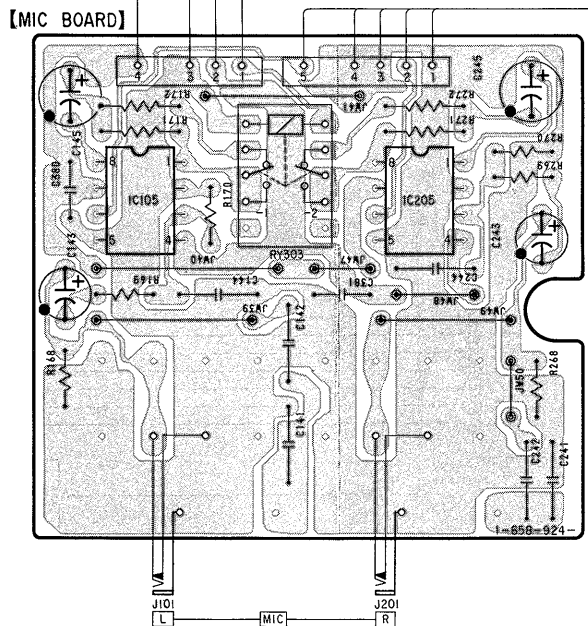
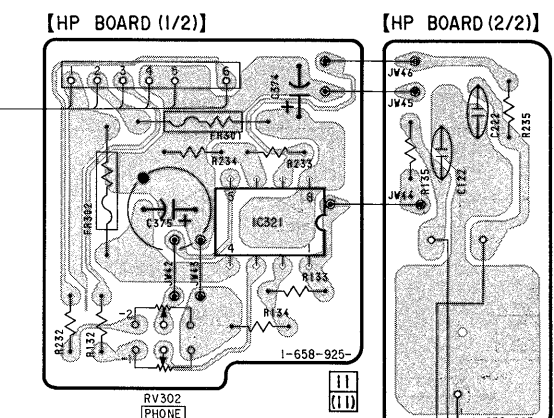
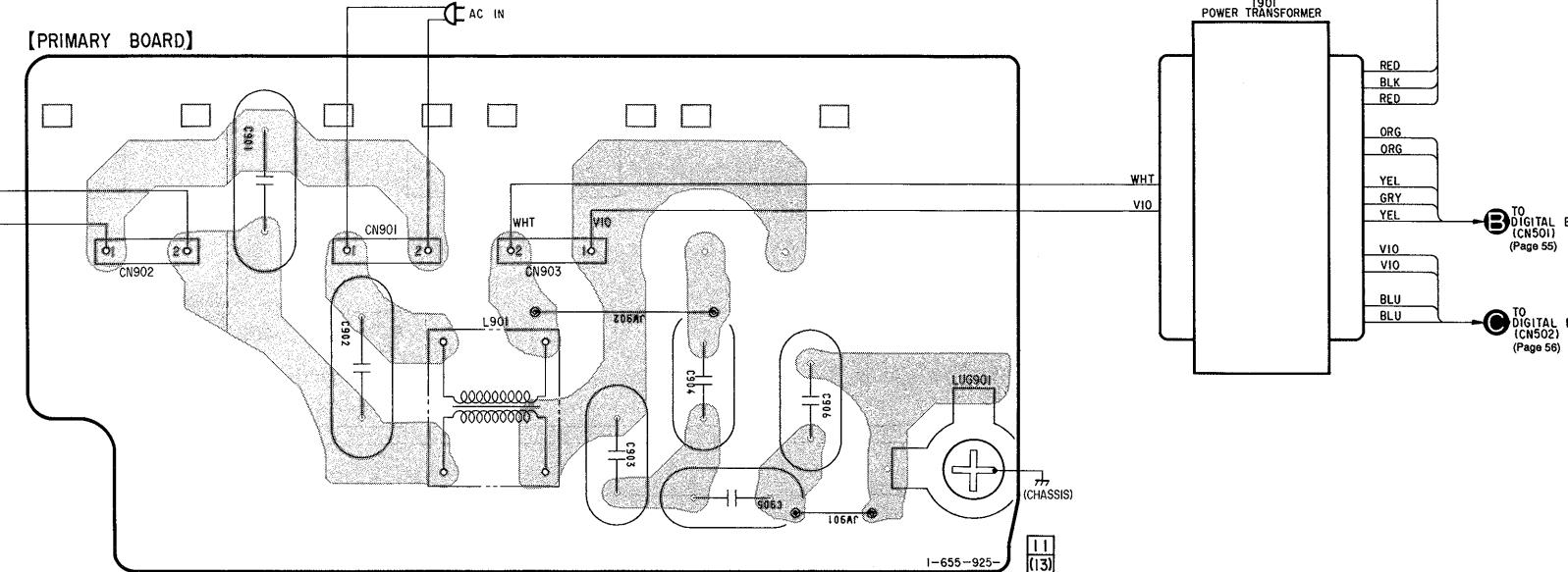
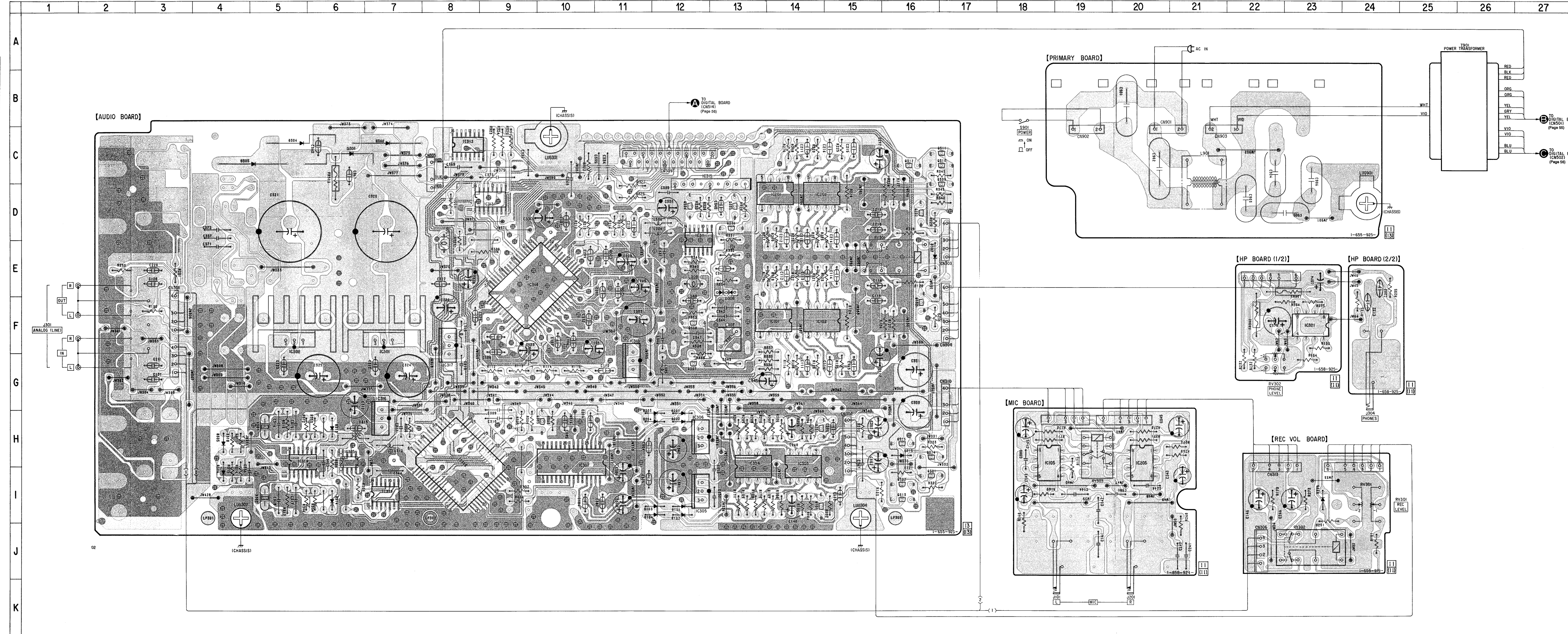



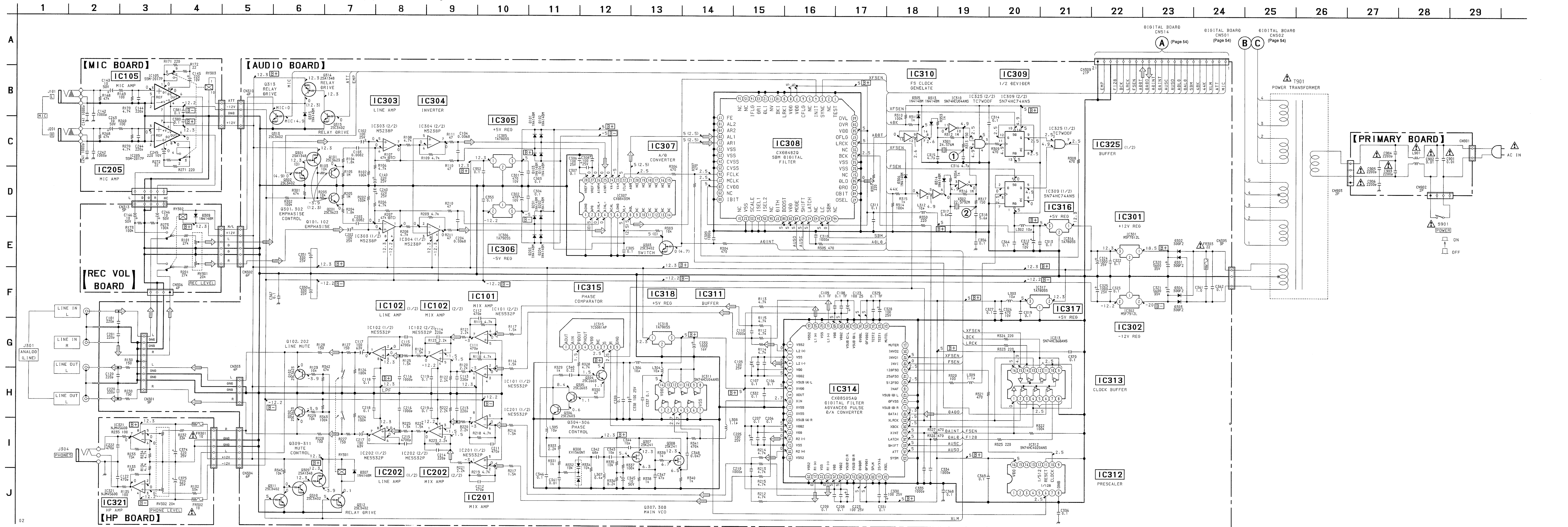

• WAVEFORMS (DIGITAL SECTION)

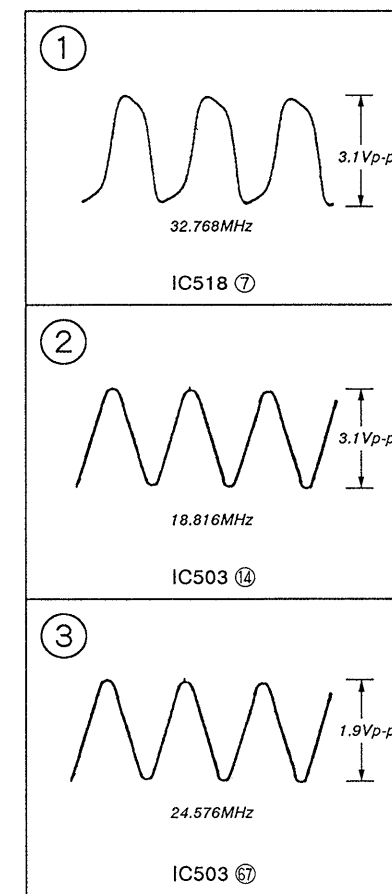

Note :

- All capacitors are in  $\mu F$  unless otherwise noted. pF:  $\mu F$  50WV or less are not indicated except for electrolytics and tantalums.
- All resistors are in  $\Omega$  and  $\frac{1}{2}W$  or less unless otherwise specified.
- : fusible resistor.

Note : The components identified by mark or dotted line with mark are critical for safety. Replace only with part number specified.

- **B+** : B+ Line
- : adjustment for repair.
- Voltage and waveforms are dc with respect to ground under no-signal (detuned) conditions.
- Voltages are taken with a VOM ( Input impedance 10M  $\Omega$  ). Voltage variations may be noted due to normal production tolerances.
- Waveforms are taken with an oscilloscope. Voltage variations may be noted due to normal production tolerances.
- Circled numbers refer to waveforms.
- Signal path.
  - : ANALOG
  - : PLAYBACK
  - : DIGITAL
  - : RECORD

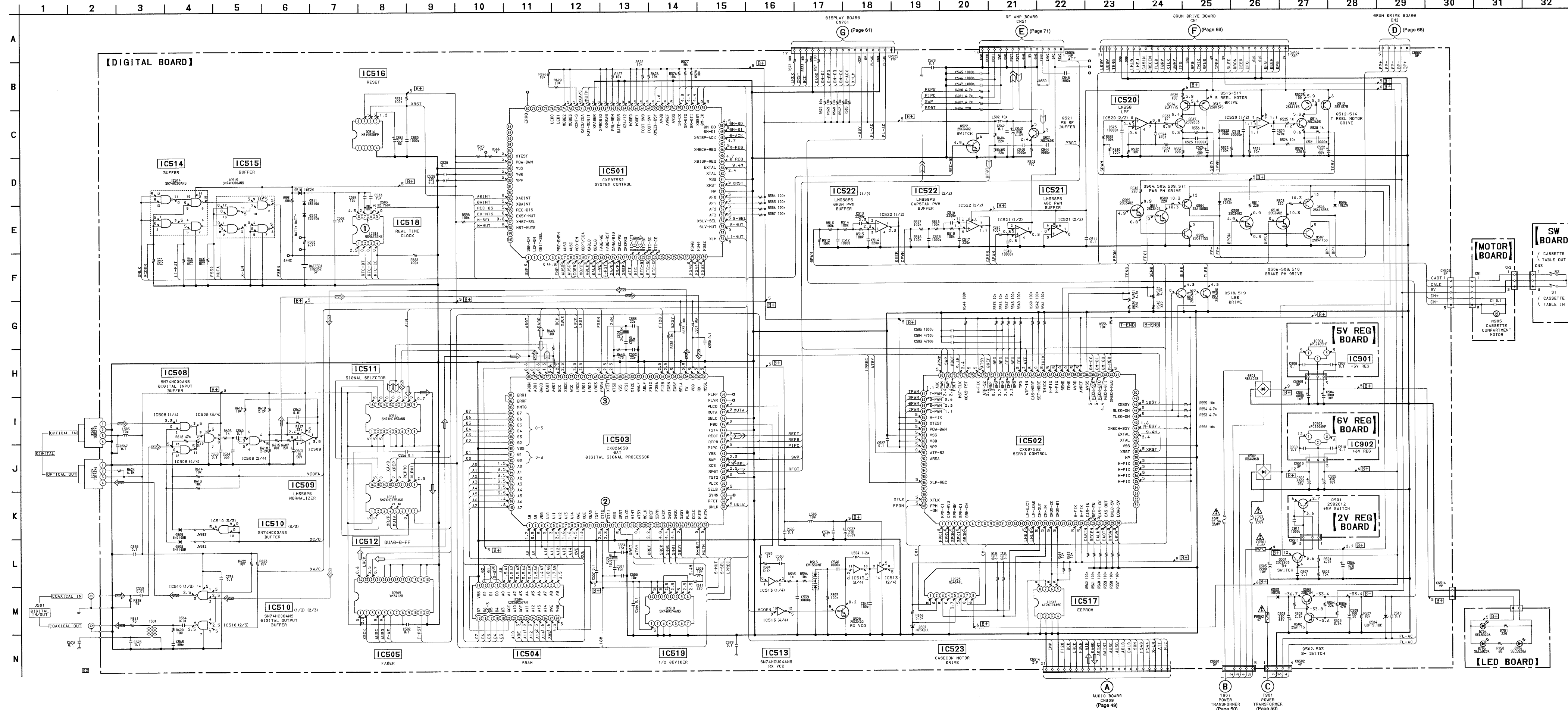



5-6. PRINTED WIRING BOARDS (DIGITAL SECTION)

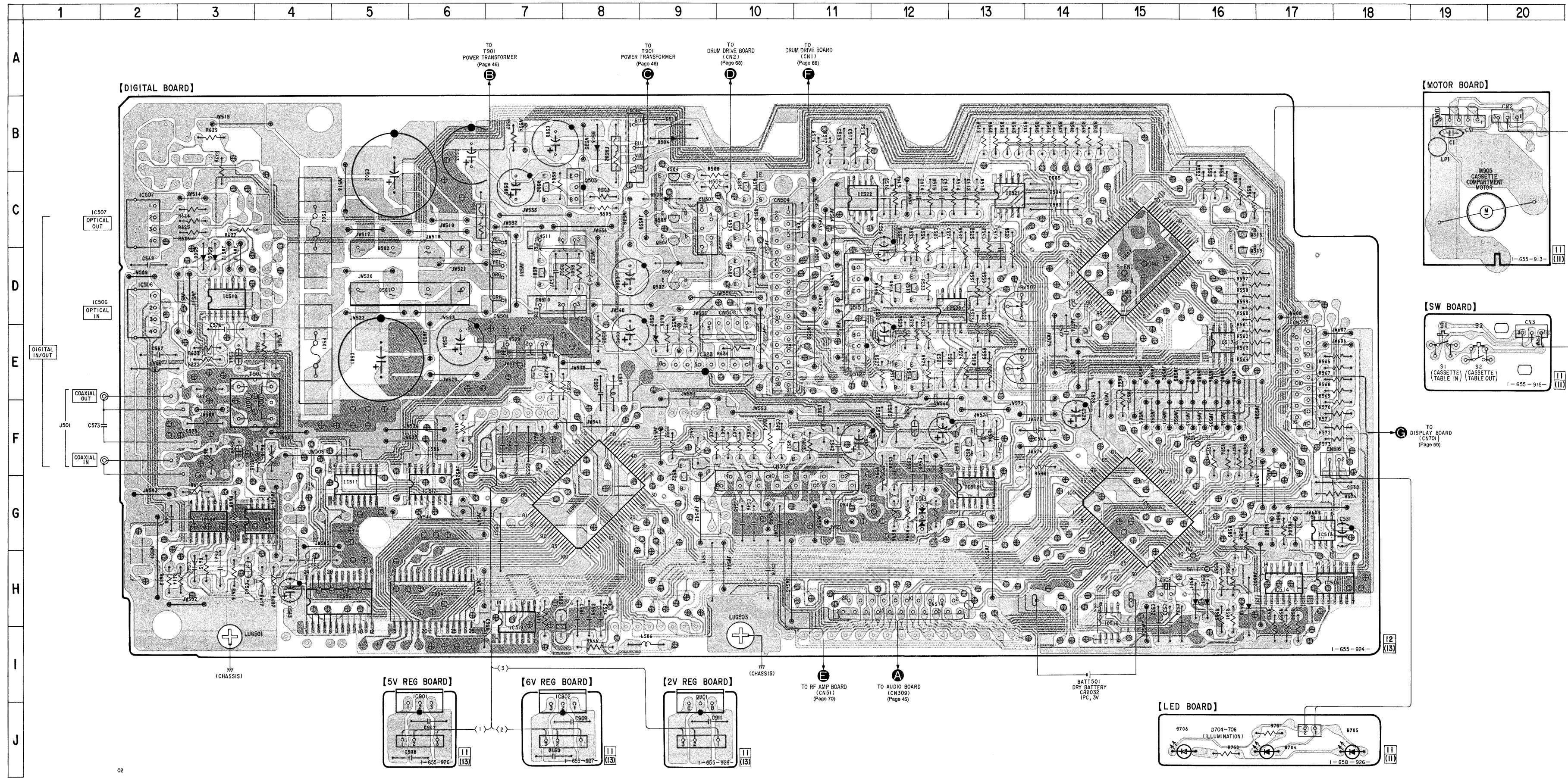

• SEMICONDUCTOR LOCATION

Ref. No.	Location	Ref. No.	Location
D501	D-5	Q517	D-12
D502	C-5	Q518	C-16
D503	B-8	Q519	D-16
D504	B-9	Q520	F-13
D505	C-9	Q521	F-10
D506	D-9	Q522	F-9
D507	E-9	Q901	I-9
D508	D-3		
D509	D-3		
D510	H-16	IC501	G-15
		IC502	D-15
D511	H-16	IC503	G-8
D512	H-16	IC504	H-6
D513	G-12	IC505	H-5
D704	J-16		
D705	J-18	IC506	D-2
		IC507	C-2
D706	J-15	IC508	G-3
		IC509	G-4
		IC510	D-3
Q501	D-7	IC511	G-5
Q502	C-7	IC512	G-6
Q503	C-8	IC513	G-13
Q504	B-9	IC514	H-17
Q505	C-9	IC515	H-17
Q506	C-9		
Q507	D-9	IC516	G-17
Q508	D-10	IC517	E-16
Q509	C-10	IC518	H-14
Q510	C-10	IC519	H-7
		IC520	D-12
Q511	C-10		
Q512	E-11	IC521	C-13
Q513	E-12	IC522	C-11
Q514	E-12	IC523	E-9
Q515	D-11	IC901	I-6
		IC902	I-7
Q516	D-12		

Note:

- : parts extracted from the component side.
- ⊕ : Through hole.
- ▨ : Pattern on the side which is seen.
- ▩ : Pattern of the rear side.



● SEMICONDUCTOR LOCATION

Ref. No.	Location
D701	H - 4
D702	H - 6
D703	H - 8
Q701	C - 4
Q702	C - 3
Q703	C - 3
Q704	F - 9
Q705	E - 9
Q706	E - 9
IC701	D - 6
IC702	E - 4
IC703	H - 11

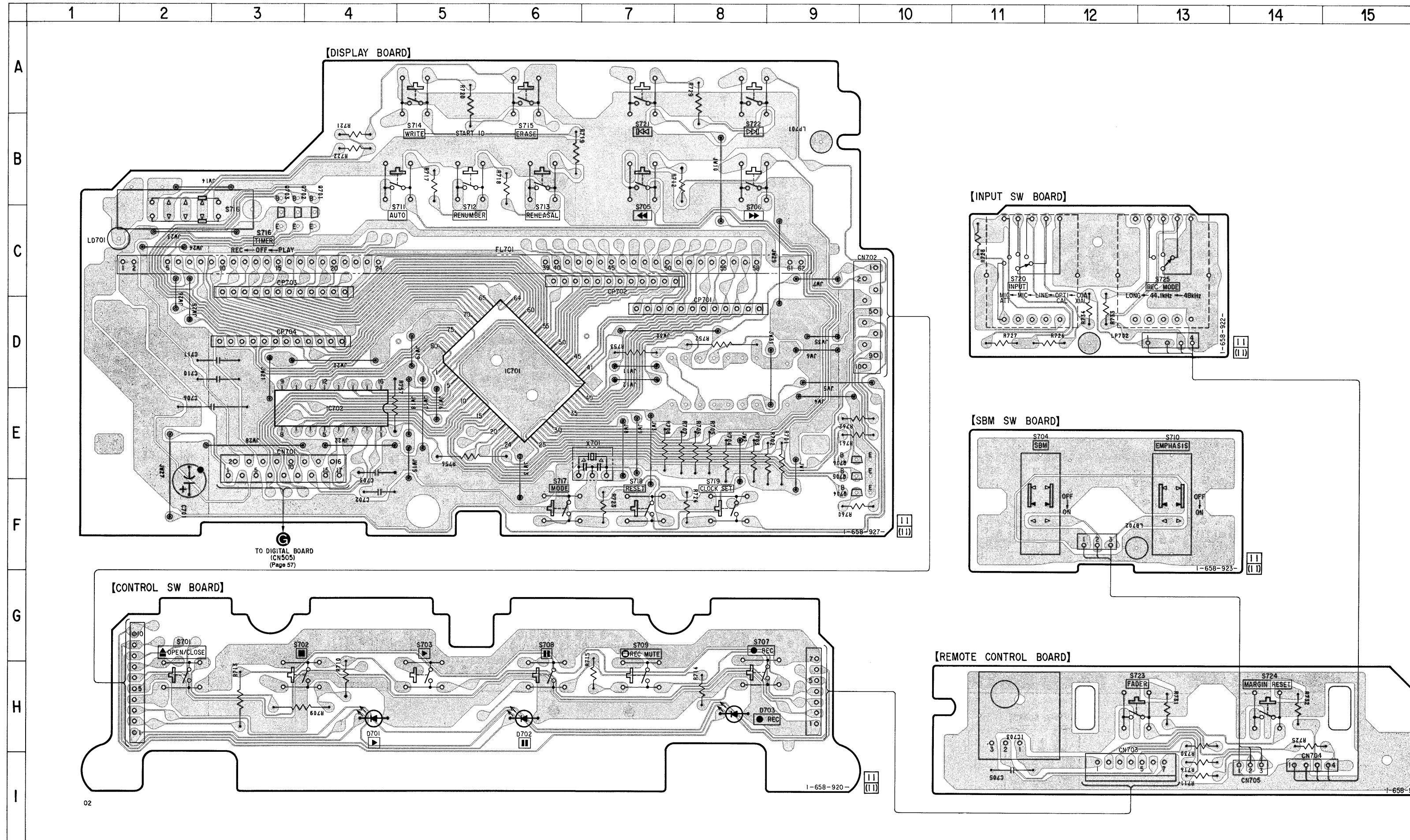

Note:  
 ○ — : parts extracted from the component side.  
 ◻ : Pattern on the side which is seen.

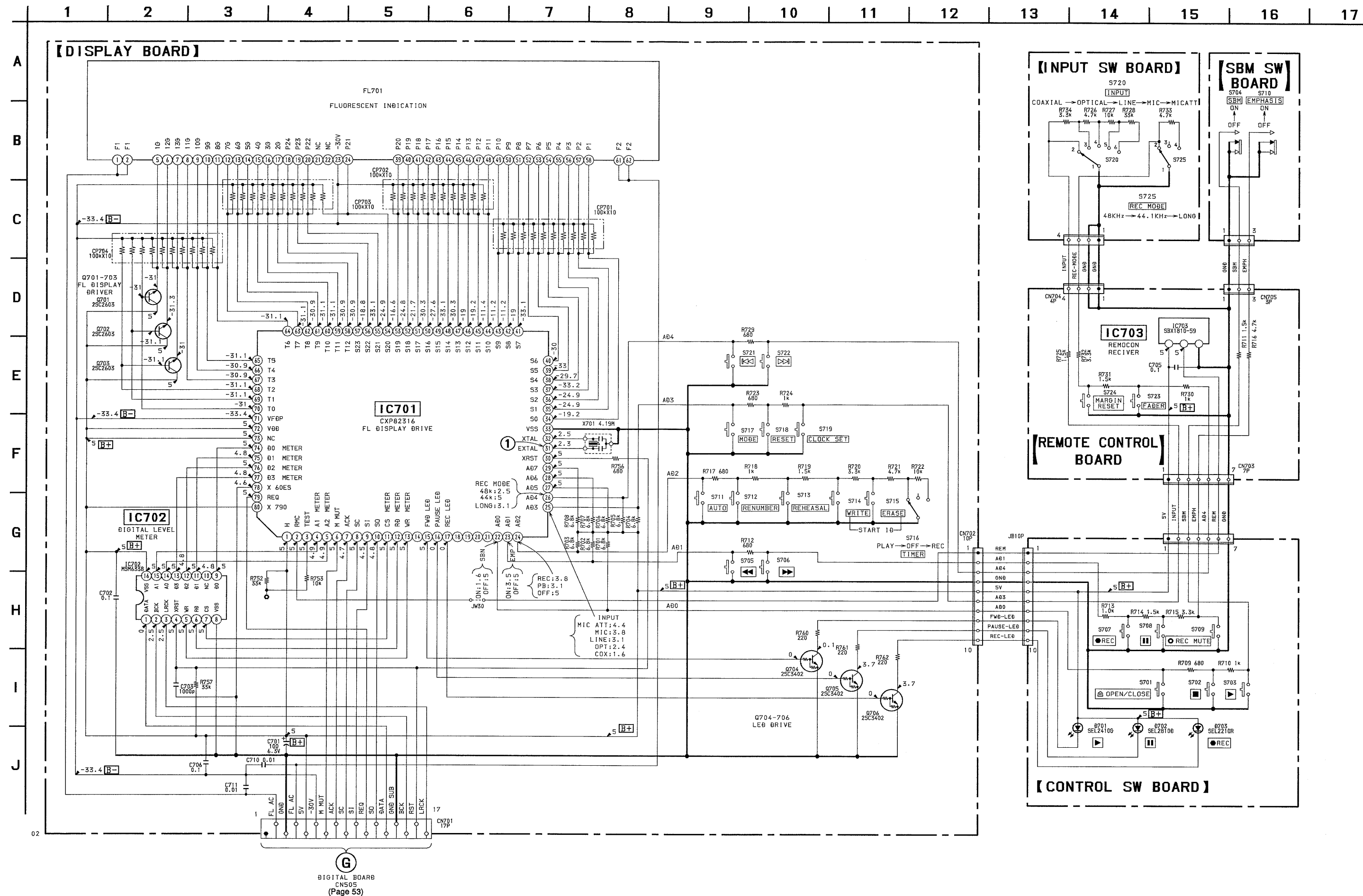

● IC BLOCK DIAGRAMS (DISPLAY SECTION)

IC702 MSM6338RS

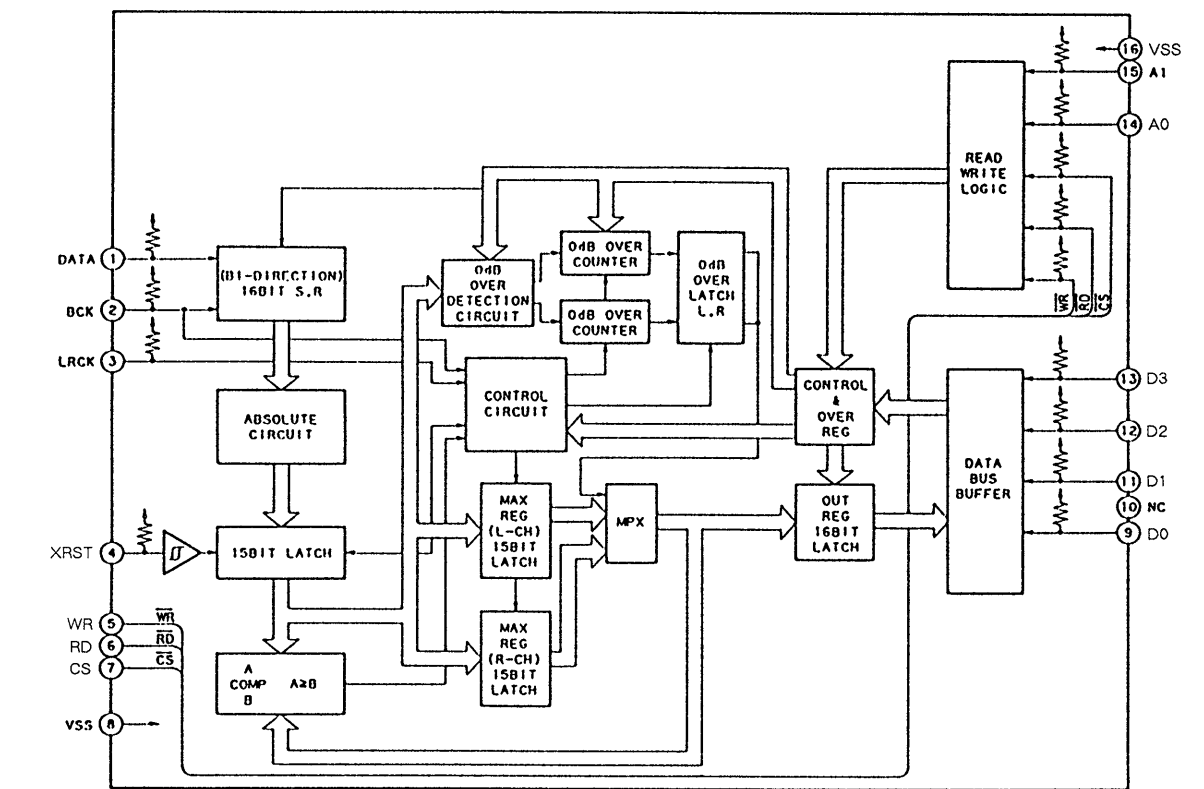

● WAVEFORMS (DISPLAY SECTION)

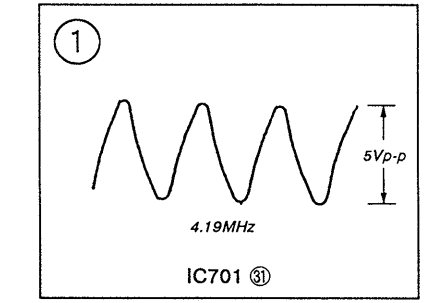

Note :

- All capacitors are in  $\mu F$  unless otherwise noted. pF:  $\mu F$  50V or less are not indicated except for electrolytics and tantalums.
- All resistors are in  $\Omega$  and  $\frac{1}{4}W$  or less unless otherwise specified.
- $\Delta$  : internal component.
- $\square$  : B+ Line
- $\square$  : B- Line
- Voltage and waveforms are dc with respect to ground under no-signal (detuned) conditions.
- Voltages are taken with a VOM ( Input impedance 10M  $\Omega$  ). Voltage variations may be noted due to normal production tolerances.
- Waveforms are taken with an oscilloscope. Voltage variations may be noted due to normal production tolerances.
- Circled numbers refer to waveforms.

• IC BLOCK DIAGRAMS (DRUM DRIVE SECTION)

IC2 M54641L

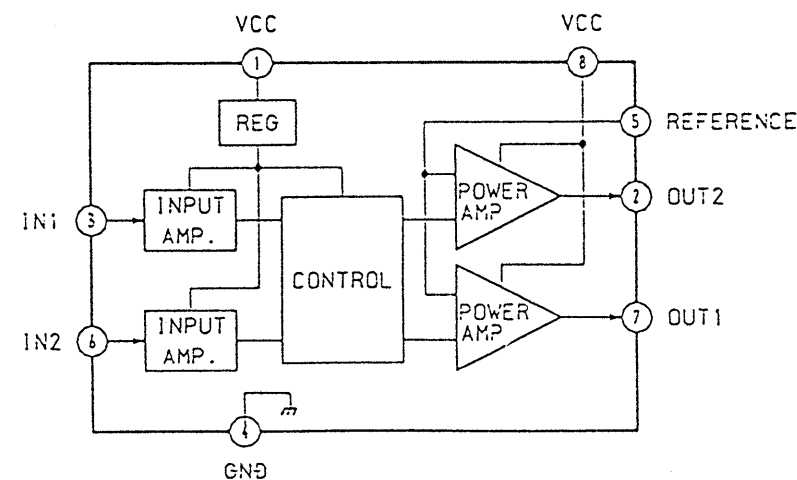

IC3 CXA20115A-T4

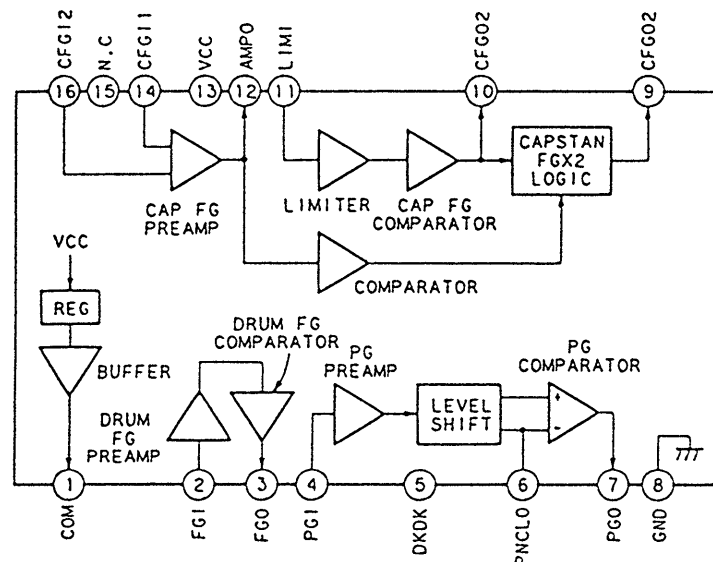

Note :

- All capacitors are in  $\mu$ F unless otherwise noted. pF:  $\mu$   $\mu$  F 50VV or less are not indicated except for electrolytics and tantalums.
- All resistors are in  $\Omega$  and  $\frac{1}{4}W$  or less unless otherwise specified.
- **[B+]** : B+ Line
- Voltage and waveforms are dc with respect to ground under no-signal (detuned) conditions.
- Voltages are taken with a VOM (Input impedance 10M  $\Omega$ ). Voltage variations may be noted due to normal production tolerances.

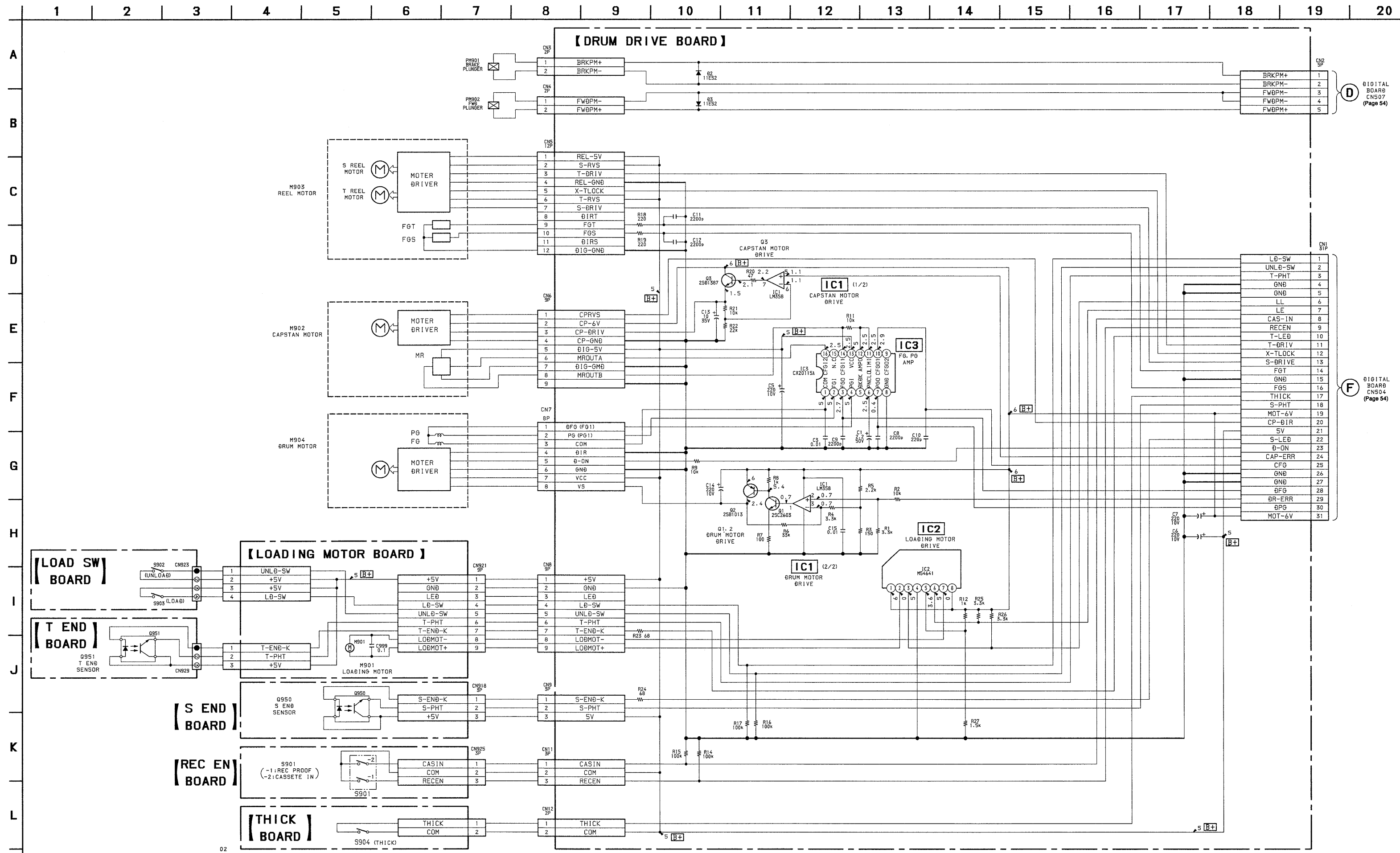

5-10. PRINTED WIRING BOARDS (DRUM DRIVE SECTION)

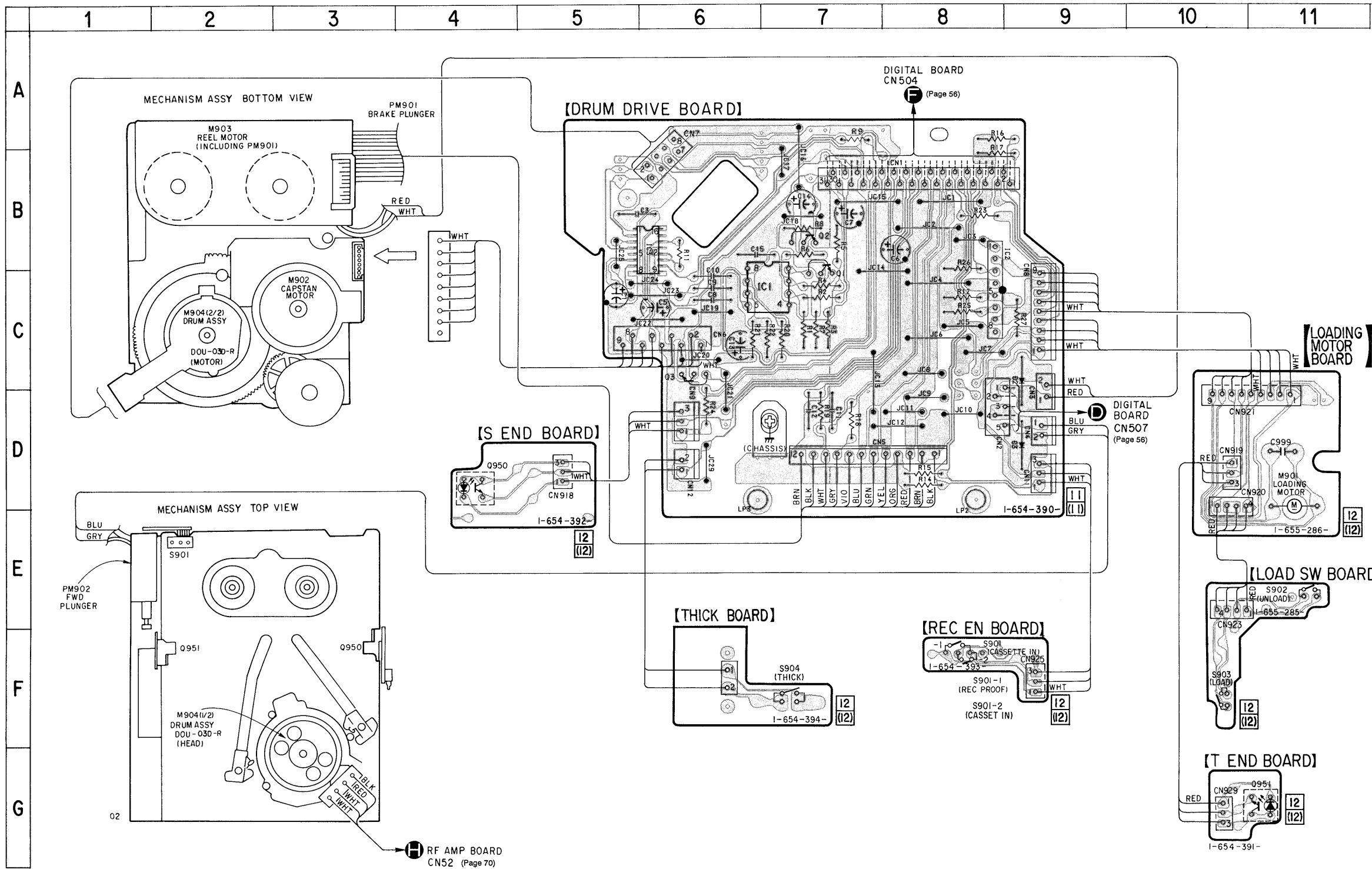

● SEMICONDUCTOR LOCATION

Ref. No.	Location
D2	C-9
D3	D-9
Q1	C-7
Q2	B-7
Q3	C-6
Q950	D-4
Q951	G-11
IC1	C-7
IC2	C-8
IC3	B-6

Note:

- : parts extracted from the component side.
- ⊙ : Pattern on the side which is seen.



5-11. PRINTED WIRING BOARDS (RF AMP SECTION)

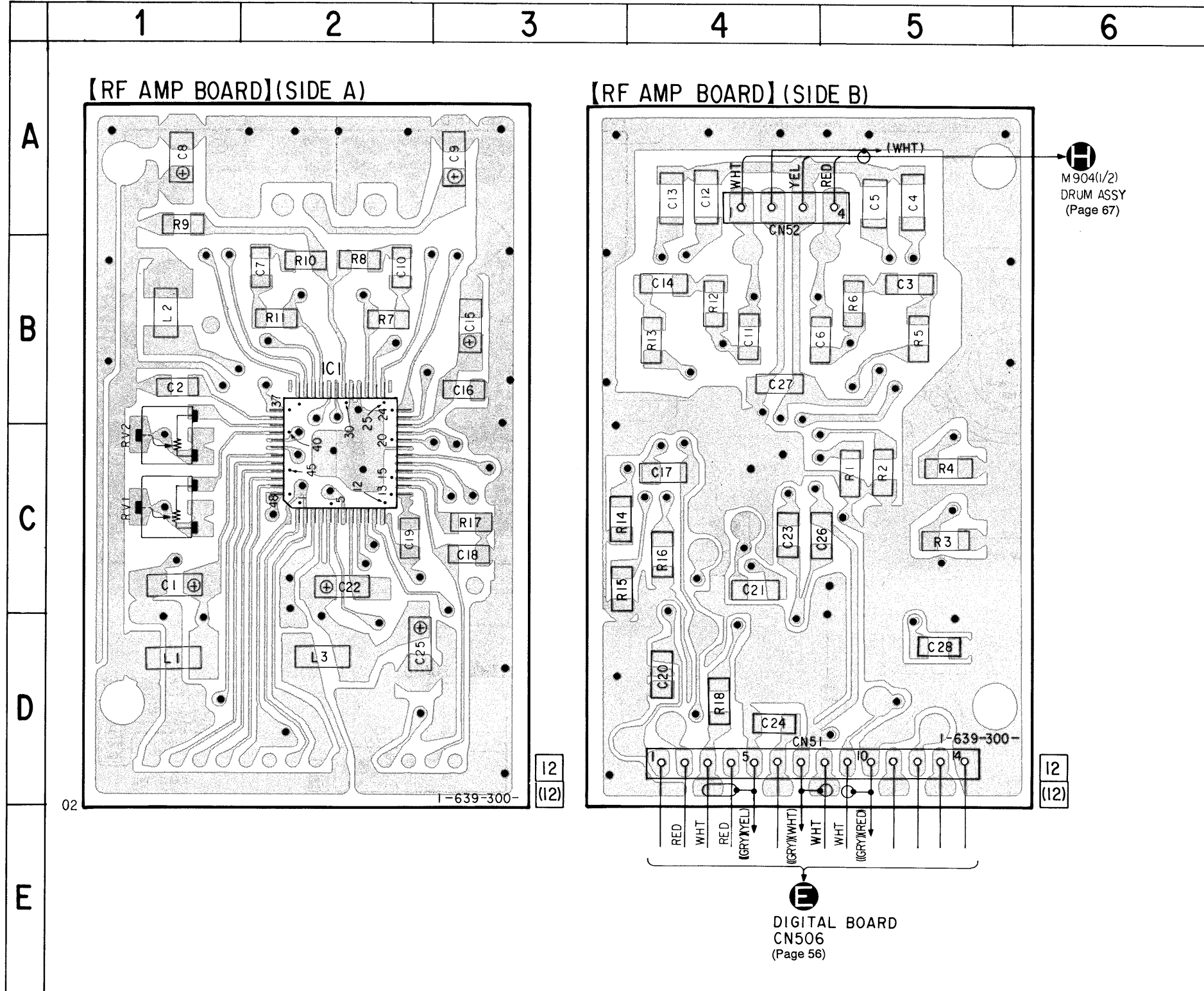

Note:

- ○ : parts extracted from the component side.
- ● : Through hole.
- [Pattern] : Pattern from the side which enables seeing. (The other layers' patterns are not indicated)

Caution :

Pattern face side : Parts on the pattern face side seen from (Side A) the pattern face are indicated.  
 Parts face side : Parts on the parts face side seen from the (Side B) parts face are indicated.



5-12. SCHEMATIC DIAGRAM (RF AMP SECTION)

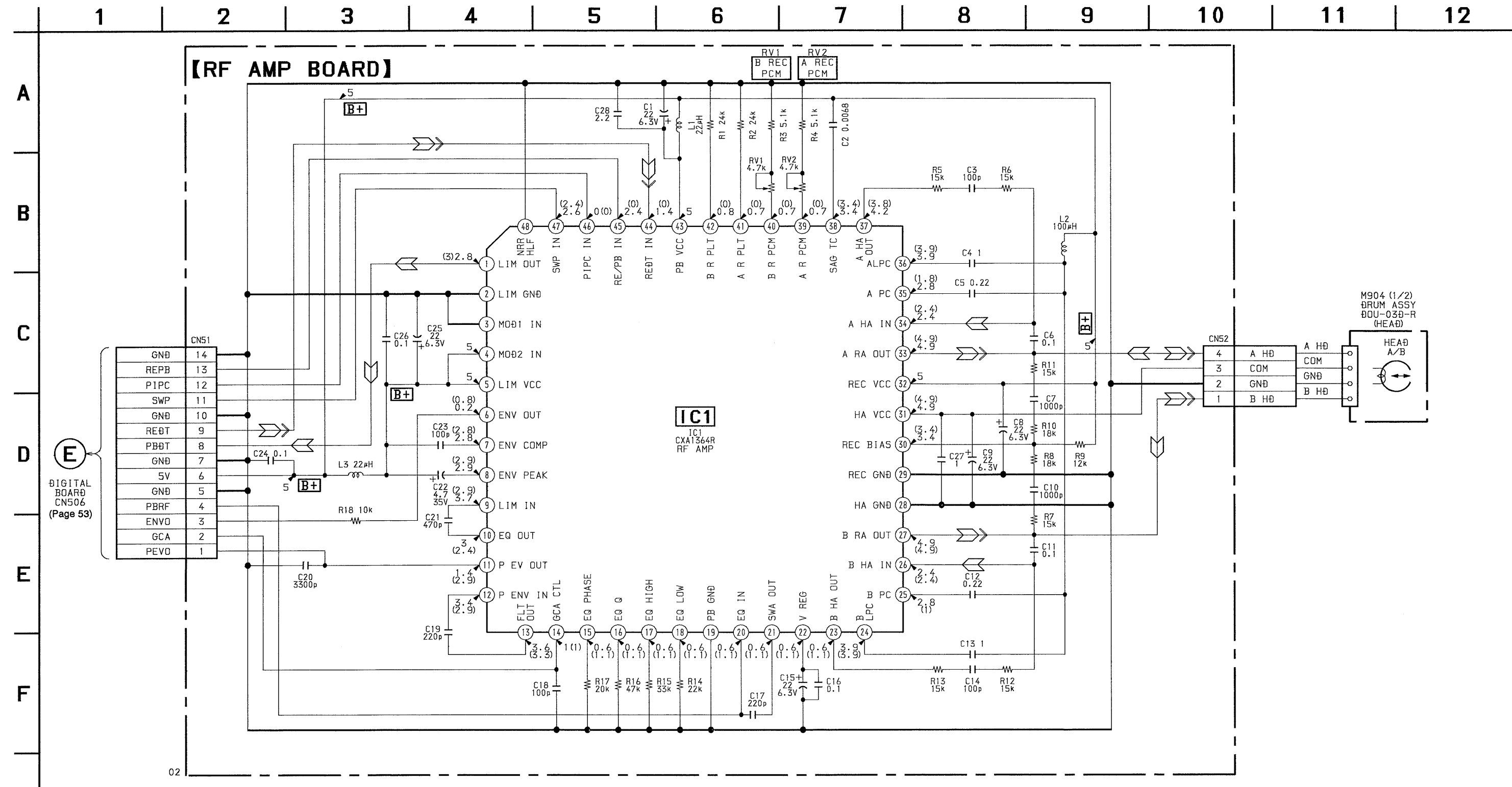

• IC BLOCK DIAGRAMS (RF AMP SECTION)  
IC1 CXA1364R

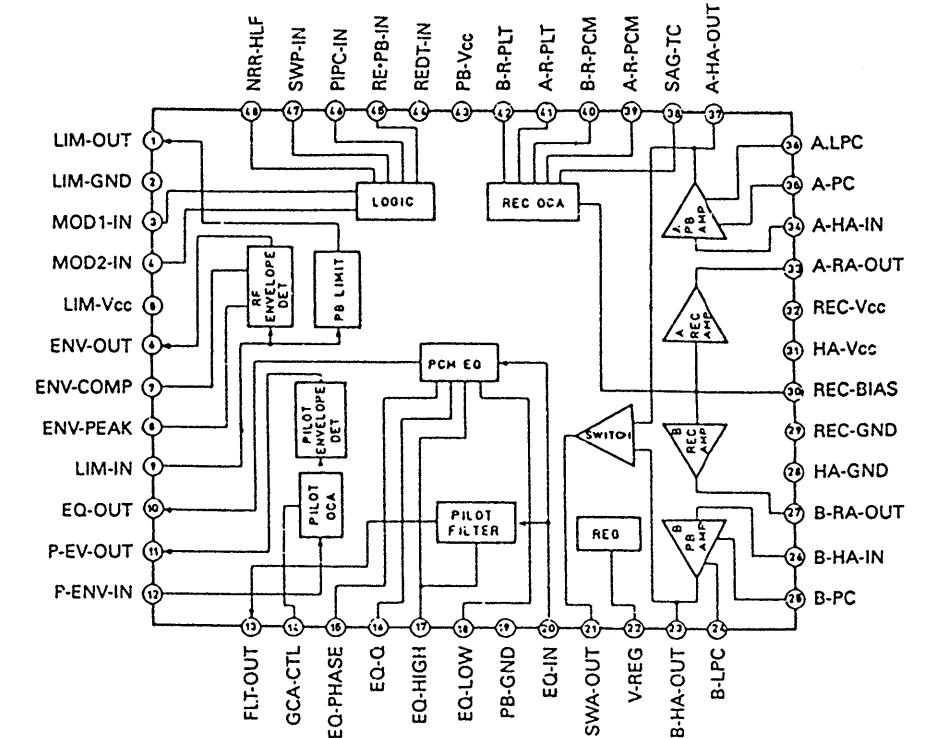

Note :

- All capacitors are in  $\mu F$  unless otherwise noted. pF:  $\mu \mu F$  50WV or less are not indicated except for electrolytics and tantalums.
- All resistors are in  $\Omega$  and  $\frac{1}{4}W$  or less unless otherwise specified.
- **B+** : B+ Line
- **□** : adjustment for repair.
- Voltage are dc with respect to ground under no-signal (detuned) conditions.  
no mark : PLAYBACK  
( ) : RECORD
- Voltages are taken with a VOM ( Input impedance 10M  $\Omega$  ).  
Voltage variations may be noted due to normal production tolerances.
- Signal path.  
  - ▷ : PLAYBACK
  - ▷▷ : RECORD

5-13. IC BLOCK DIAGRAM  
(AUDIO SECTION)

IC307 CXD8493M-E1

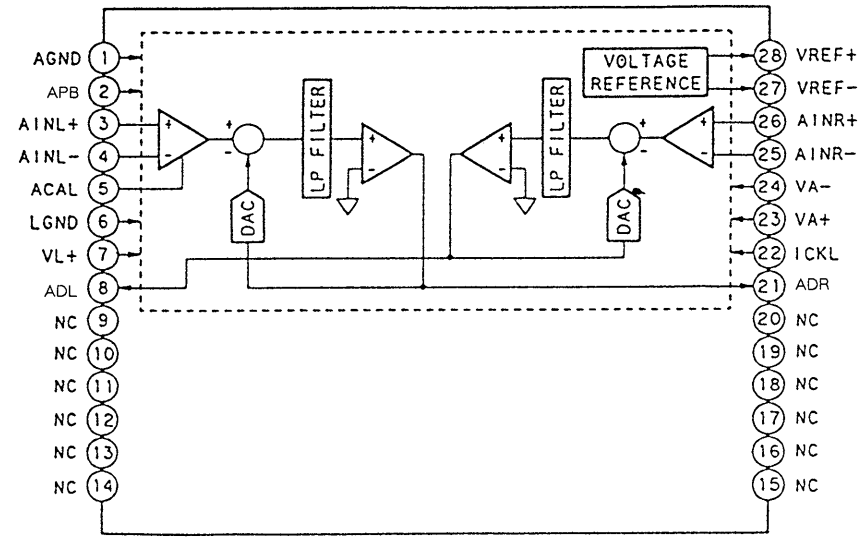

IC308 CDX8482Q

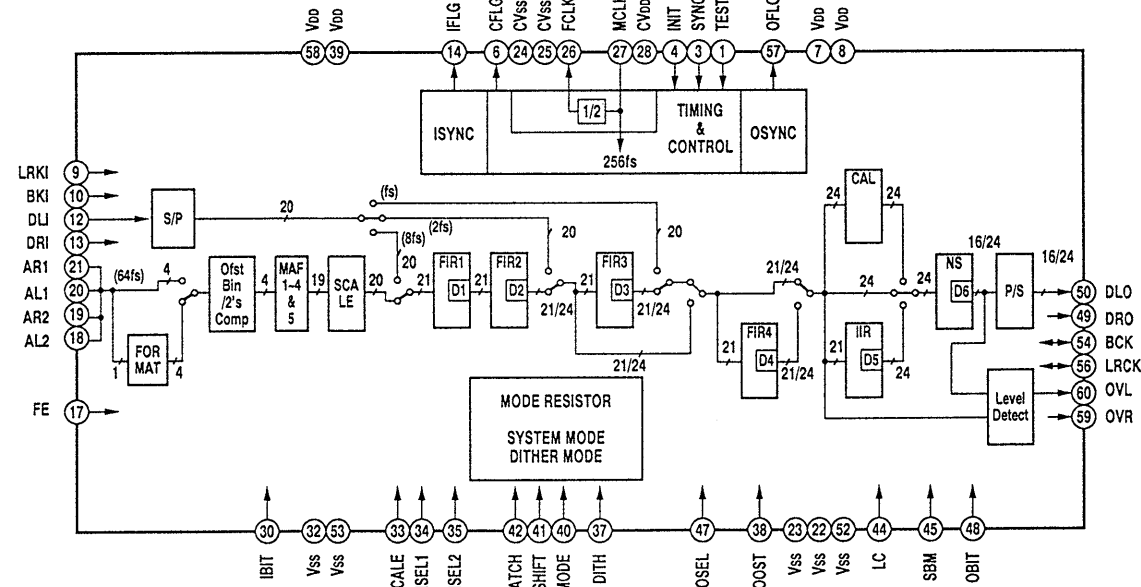

IC312 SN74HC4020ANS

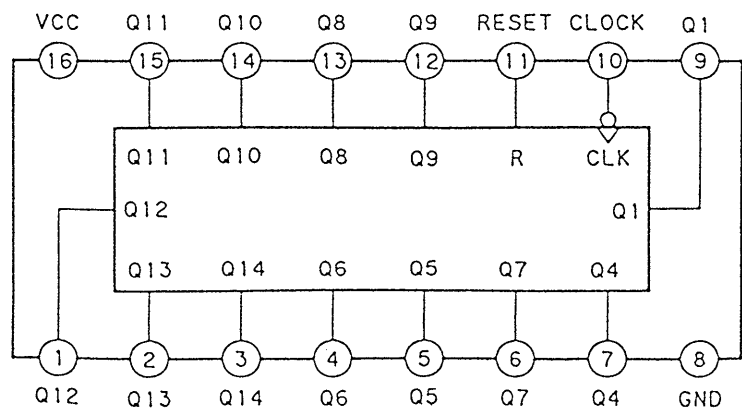

IC314 CXD8505AQ

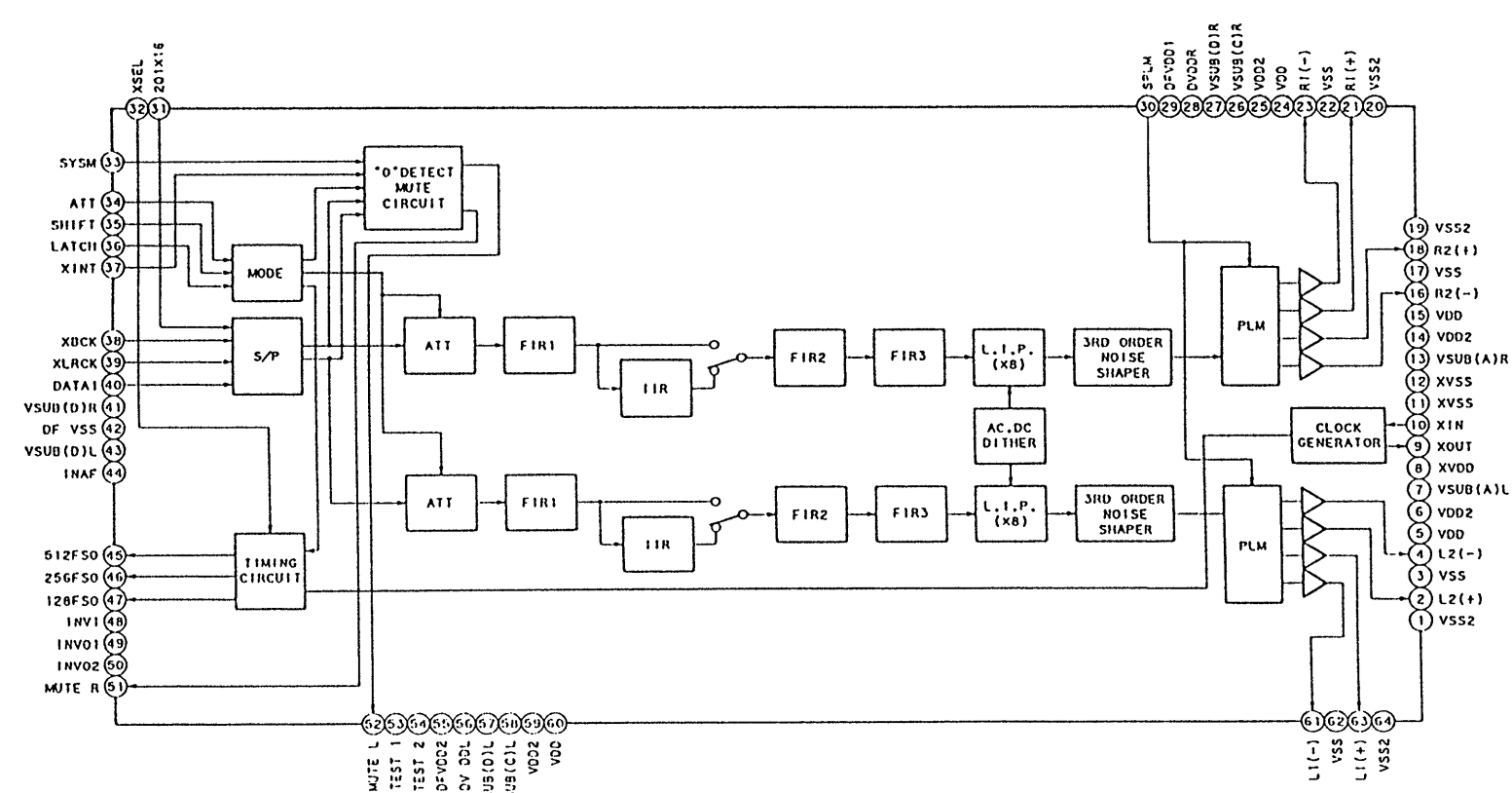

IC315 TC5081AP

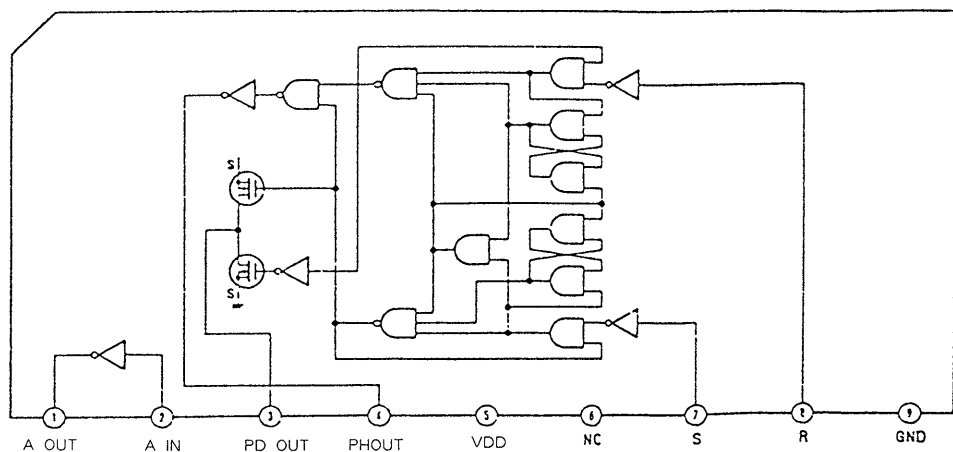

(DIGITAL SECTION)  
IC503 CXD2605Q

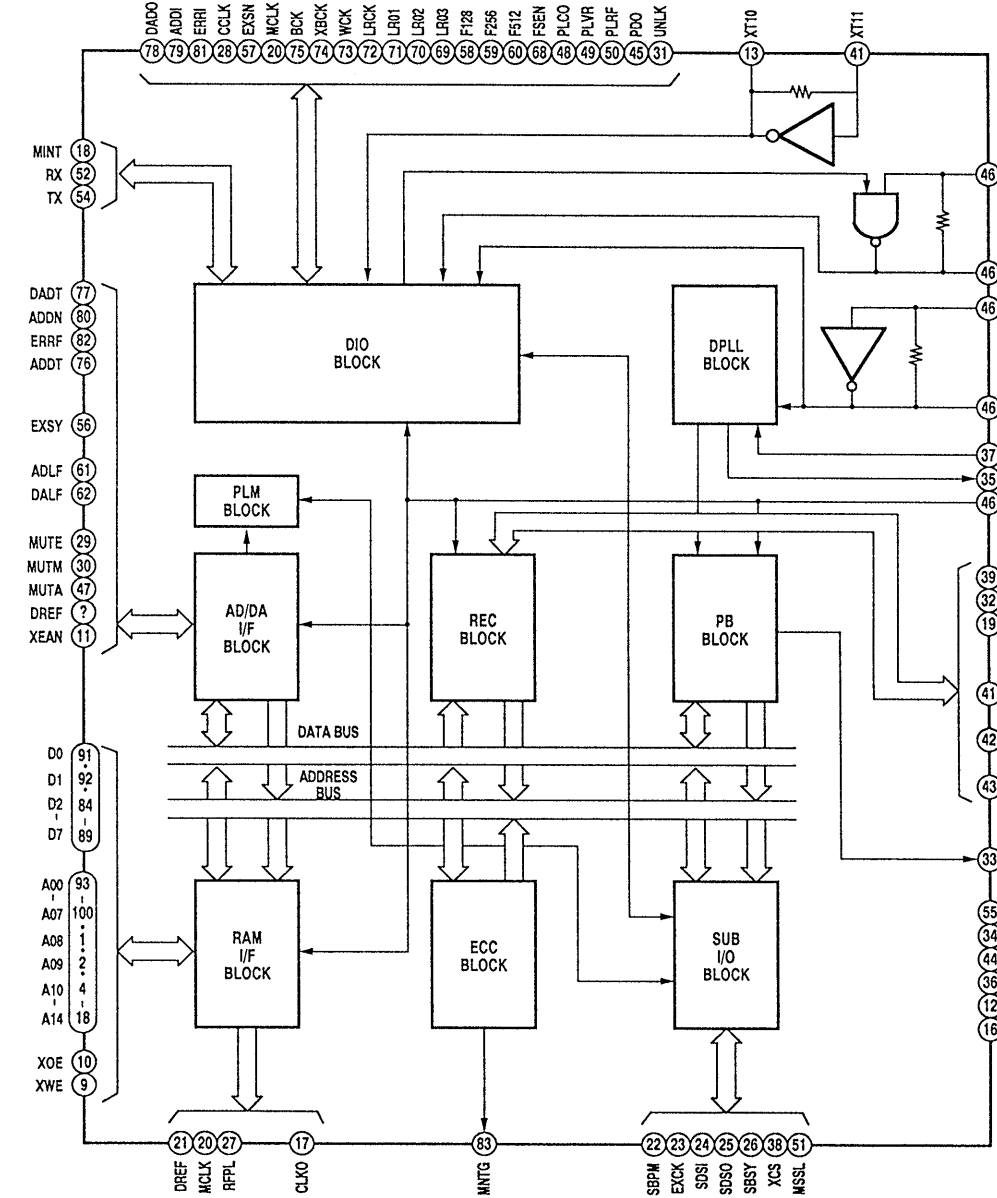

IC512 MC74HC175F

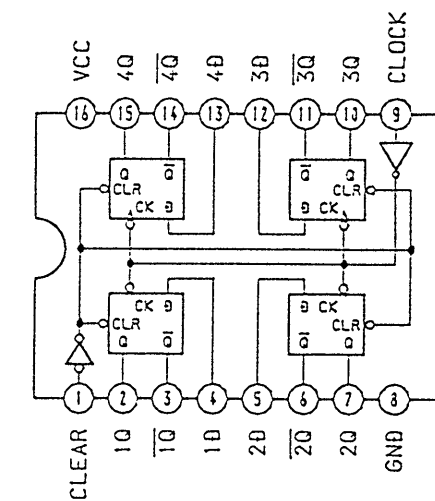

IC516 M51953BFP

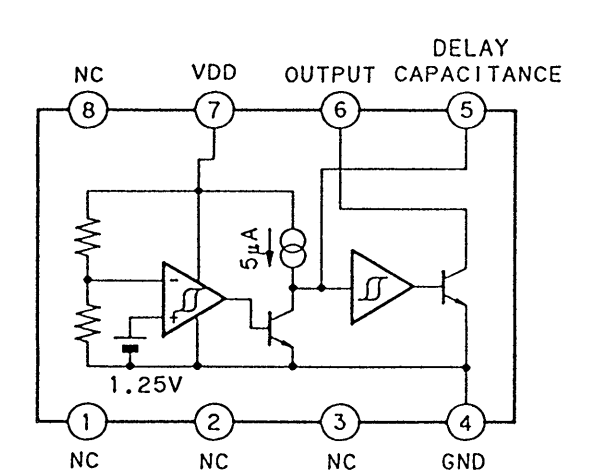

IC504 CXK58257AM

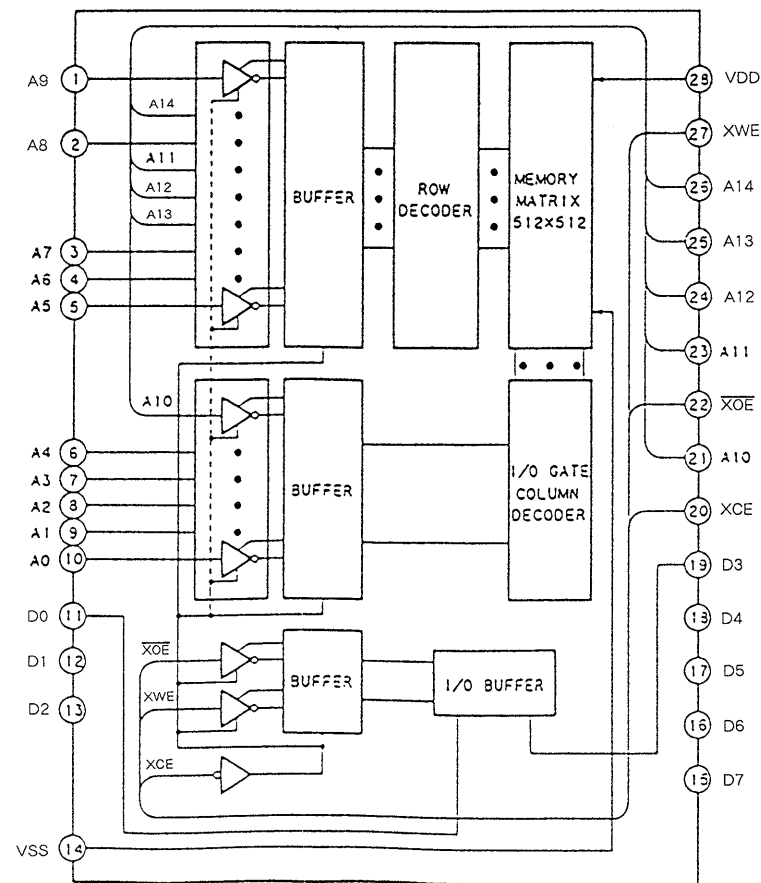

IC511 SN74HC153ANS

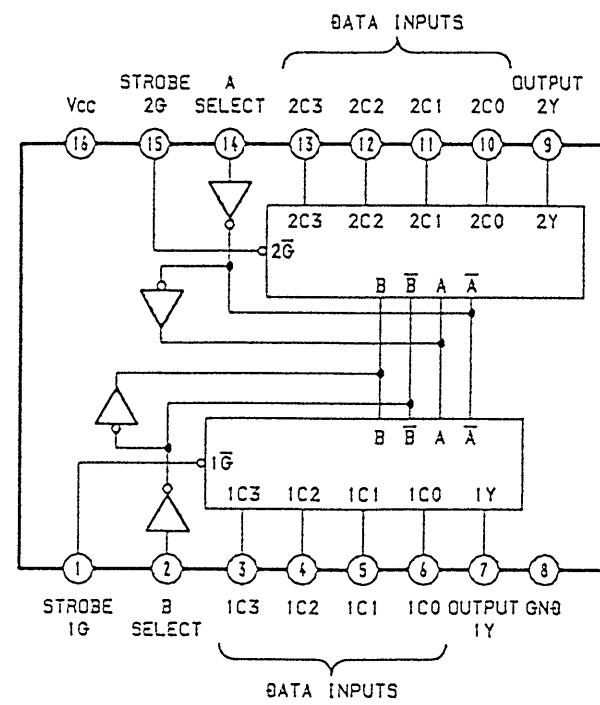

IC517 AT24C01A10SC

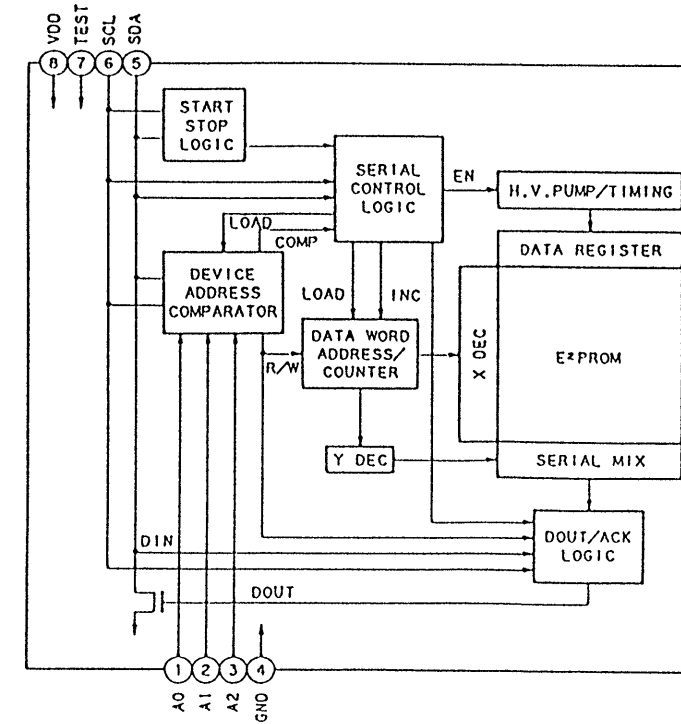

IC519 SN74HC74ANS

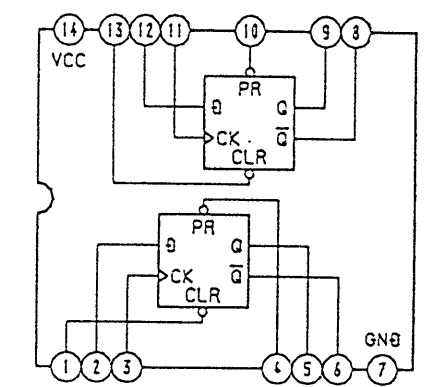

IC505 YM3412B

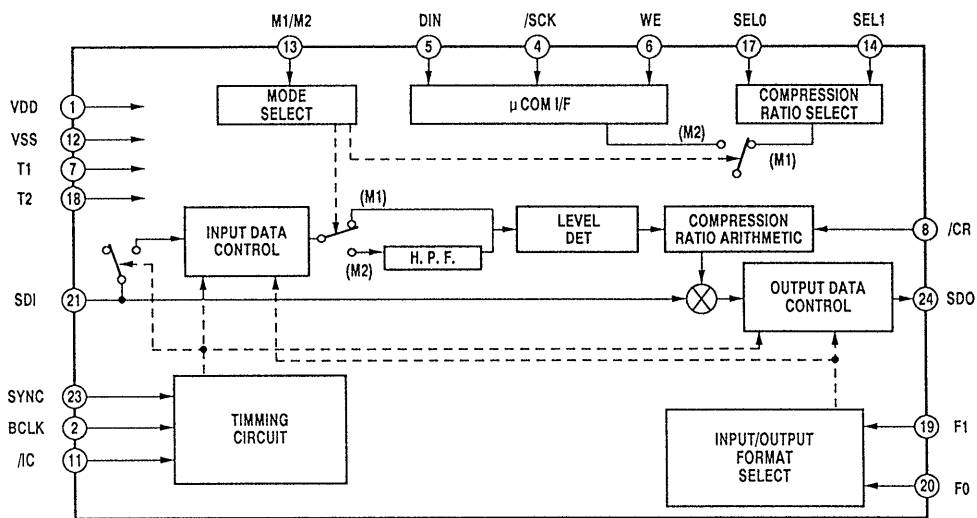

IC523 M54641L

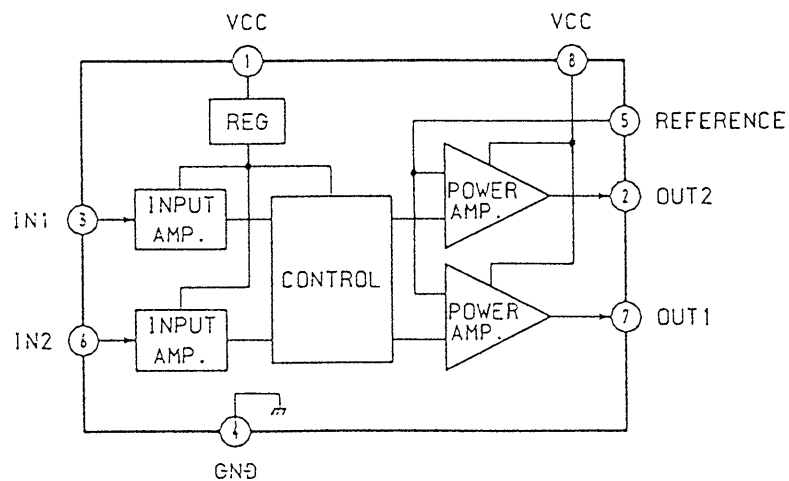

IC518 MSM6782-01MS

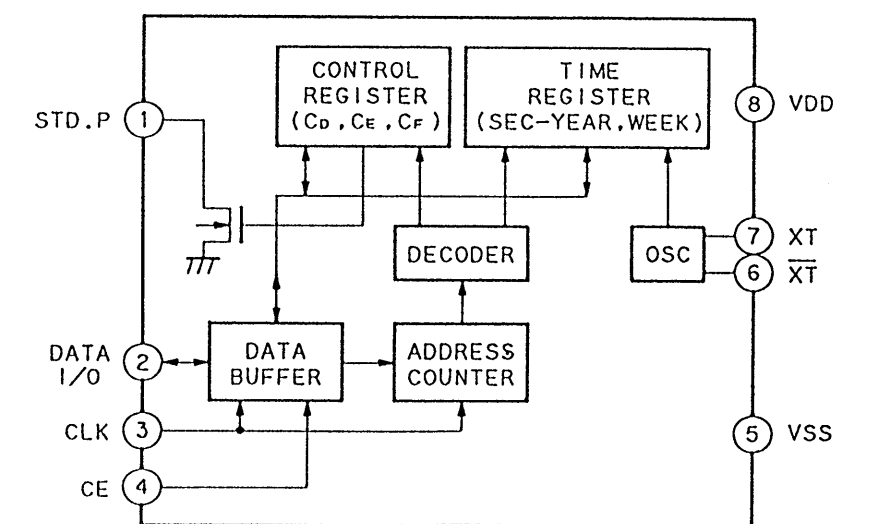

## SECTION 6 EXPLODED VIEWS

**NOTE :**

- -XX, -X mean standardized parts, so they may have some difference from the original one.
- The construction parts of an assembled part are indicated with a collation number in the remark column.

- Color indication of Appearance Parts  
Example :  
KNOB, BALANCE (WHITE)...(RED)

Parts color      Cabinet's color

The components identified by mark  $\Delta$  or dotted line with mark  $\Delta$  are critical for safety. Replace only with part number specified.

- Items marked " \* " are not stocked since they are seldom required for routine service. Some delay should be anticipated when ordering these items.

- The mechanical parts with no reference number in the exploded views are not supplied.
- Hardware ( # mark ) list and accessories and packing materials are given in the last of this parts list.

### 6-1. CHASSIS SECTION

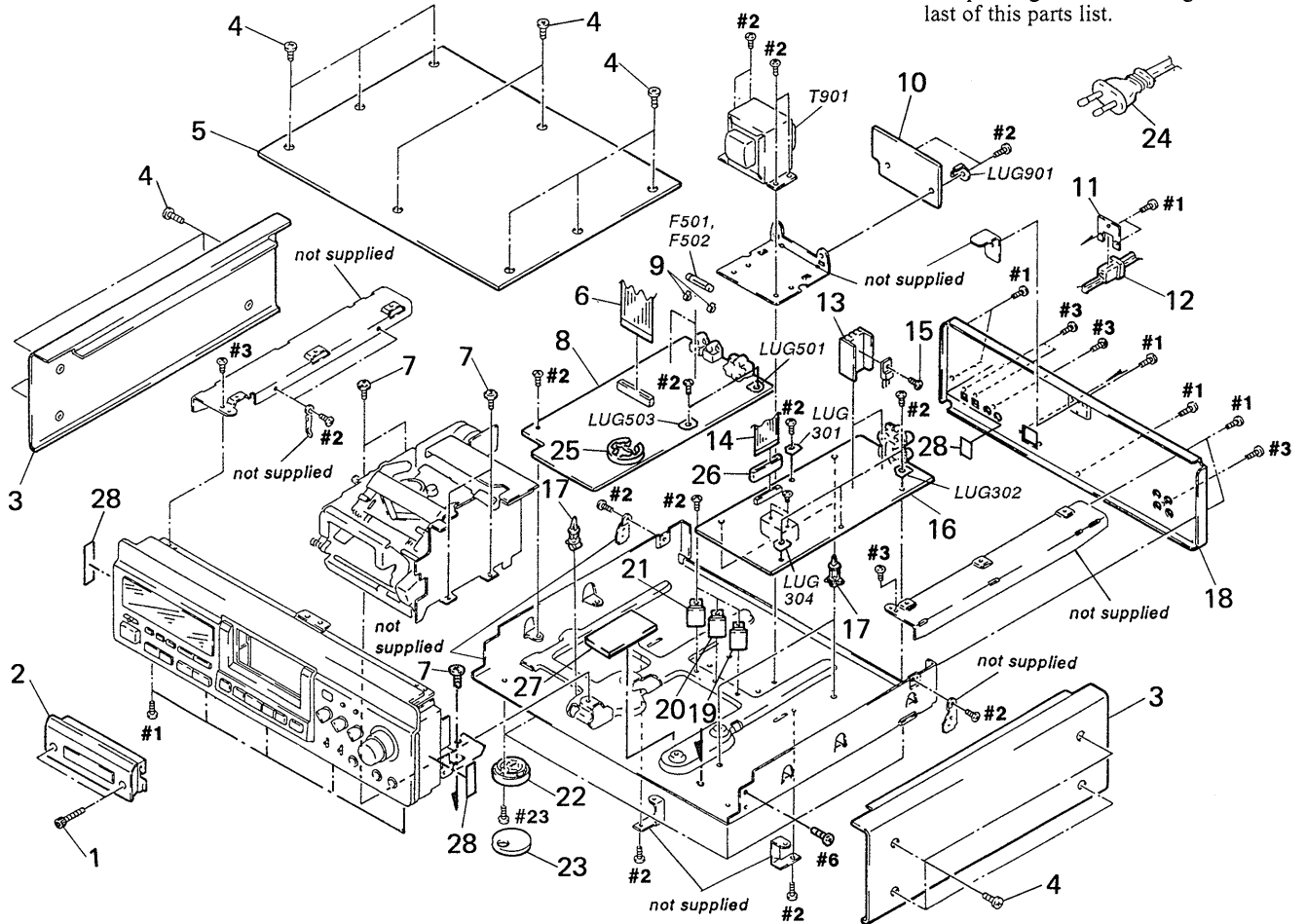

Ref. No.	Part No.	Description	Remark	Ref. No.	Part No.	Description	Remark
1	3-910-074-01	BOLT (M3) (GOLD)		17	4-924-098-01	HOLDER, PC BOARD	
1	3-910-074-11	BOLT (M3) (BLACK)		* 18	3-926-675-11	PANEL (BACK)	
2	A-2004-521-A	PANEL (B) ASSY (BLACK)		* 19	1-655-928-11	2V REG BOARD	
2	A-2004-522-A	PANEL (N) ASSY (GOLD)		* 20	1-655-927-11	6V REG BOARD	
3	3-926-822-01	PANEL (SIDE) (BLACK)		* 21	1-655-926-11	5V REG BOARD	
3	3-926-822-11	PANEL (SIDE) (GOLD)		22	4-970-123-01	FOOT (F50180S)	
4	4-924-242-11	SCREW (M3×6), FLAT HEAD (BLACK)		23	4-970-124-01	CUSHION (F50180S)	
4	4-924-242-61	SCREW (M3×6), FLAT HEAD (GOLD)		$\Delta$ 24	1-558-568-21	CORD, POWER	
5	3-927-006-01	PANEL (TOP) (BLACK)		25	1-550-414-21	HOLDER, BATTERY	
5	3-927-006-11	PANEL (TOP) (GOLD)		26	1-543-762-11	BEAD, FERRITE	
6	1-776-000-11	WIRE (FLAT TYPE) (31 CORE)		* 27	4-922-943-01	DUMPER	
7	4-886-821-11	SCREW, S TIGHT, +PTWH 3×6		28	3-831-441-XX	CUSHION, SPEAKER	
* 8	A-2007-454-A	DIGITAL BOARD, COMPLETE		$\Delta$ F501	1-532-286-00	FUSE (T2. 5A 250V)	
9	1-533-293-11	FUSE HOLDER		$\Delta$ F502	1-532-286-00	FUSE (T2. 5A 250V)	
* 10	1-655-925-11	PRIMARY BOARD		LUG301	1-537-770-21	TERMINAL BOARD, GROUND	
* 11	4-923-873-01	BRACKET, CORD STOPPER		LUG302	1-537-770-21	TERMINAL BOARD, GROUND	
* 12	3-703-244-00	BUSHING (2104), CORD		LUG304	1-537-770-21	TERMINAL BOARD, GROUND	
* 13	4-363-146-71	HEAT SINK, V. OUT		LUG501	1-537-770-21	TERMINAL BOARD, GROUND	
14	1-776-001-11	WIRE (FLAT TYPE) (21 CORE)		LUG503	1-537-770-21	TERMINAL BOARD, GROUND	
15	2-259-121-01	SCREW, TR		* LUG901	3-346-266-12	PLATE, GROUND	
* 16	A-2007-453-A	AUDIO BOARD, COMPLETE		$\Delta$ T901	1-427-913-11	TRANSFORMER, POWER	

## 6-2. FRONT PANEL SECTION

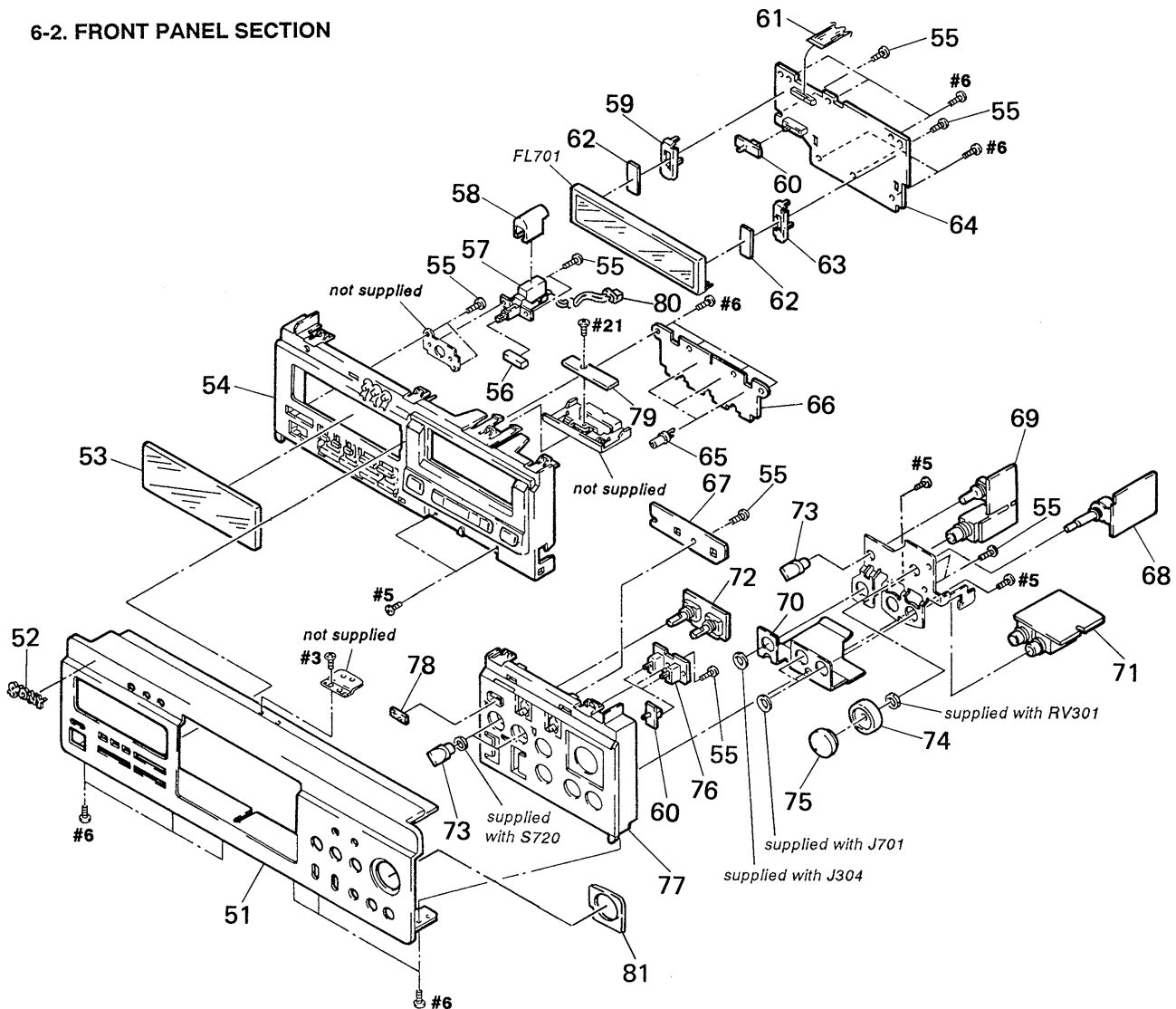

Ref. No.	Part No.	Description	Remark	Ref. No.	Part No.	Description	Remark
51	3-926-997-01	PANEL (FRONT) (BLACK)		* 67	1-658-921-11	REMOTE CONTROL BOARD	
51	3-926-997-11	PANEL (FRONT) (GOLD)		* 68	1-658-919-11	REC VOL BOARD	
52	4-942-568-01	EMBLEM (NO. 5), SONY (BLACK)		* 69	1-658-925-11	HP BOARD	
52	4-942-568-21	EMBLEM (NO. 5), SONY (GOLD)		* 70	3-930-019-01	PLATE (HP & MIC), GROUND	
53	3-927-000-01	WINDOW (FL TUBE)		* 71	1-658-924-11	MIC BOARD	
54	X-3371-157-1	BASE (PANEL L/B) COMPLETE ASSY (BLACK)		* 72	1-658-922-11	INPUT SW BOARD	
54	X-3371-158-1	BASE (PANEL L/B) COMPLETE ASSY (GOLD)		73	X-3362-818-1	KNOB (DIA. 12) ASSY (B), FLAT (BLACK)	
55	4-951-620-01	SCREW (2.6×8), +BVTP		73	X-3363-490-1	KNOB (DIA. 12) ASSY (B), FLAT (GOLD)	
56	4-922-921-31	BUTTON (POWER) (BLACK)		74	3-919-248-01	KNOB (R) (BLACK)	
56	4-922-921-51	BUTTON (POWER) (GOLD)		74	3-919-248-11	KNOB (R) (GOLD)	
57	1-572-267-51	SWITCH, PUSH (AC POWER) (1 KEY)		75	3-919-247-01	KNOB (L) (BLACK)	
58	3-575-524-00	COVER, POWER SWITCH		75	3-919-247-11	KNOB (L) (GOLD)	
* 59	4-922-524-01	HOLDER (LEFT)		* 76	1-658-923-11	SBM SW BOARD	
60	3-919-257-01	KNOB (TIMER) (BLACK)		77	3-927-004-01	BASE (PANEL R) (BLACK)	
60	3-919-257-11	KNOB (TIMER) (GOLD)		77	3-927-004-11	BASE (PANEL R) (GOLD)	
61	1-769-541-11	WIRE (FLAT TYPE) (17 CORE)		78	4-969-185-01	WINDOW (REMOTE CONTROL)	
* 62	4-955-901-01	CUSHION (FL)		* 79	1-658-926-11	LED BOARD	
* 63	4-922-523-01	HOLDER (RIGHT)		80	1-776-002-11	CORD (WITH CONNECTOR)	
* 64	A-2007-452-A	DISPLAY BOARD, COMPLETE		81	3-919-226-01	ESCUTCHEON (VOL) (BLACK)	
* 65	3-362-478-01	HOLDER (T), LED		81	3-919-226-11	ESCUTCHEON (VOL) (GOLD)	
* 66	1-658-920-11	CONTROL SW BOARD		FL701	1-517-382-11	INDICATOR TUBE, FLUORESCENT	

### 6-3. CASSETTE COMPARTMENT SECTION (1)

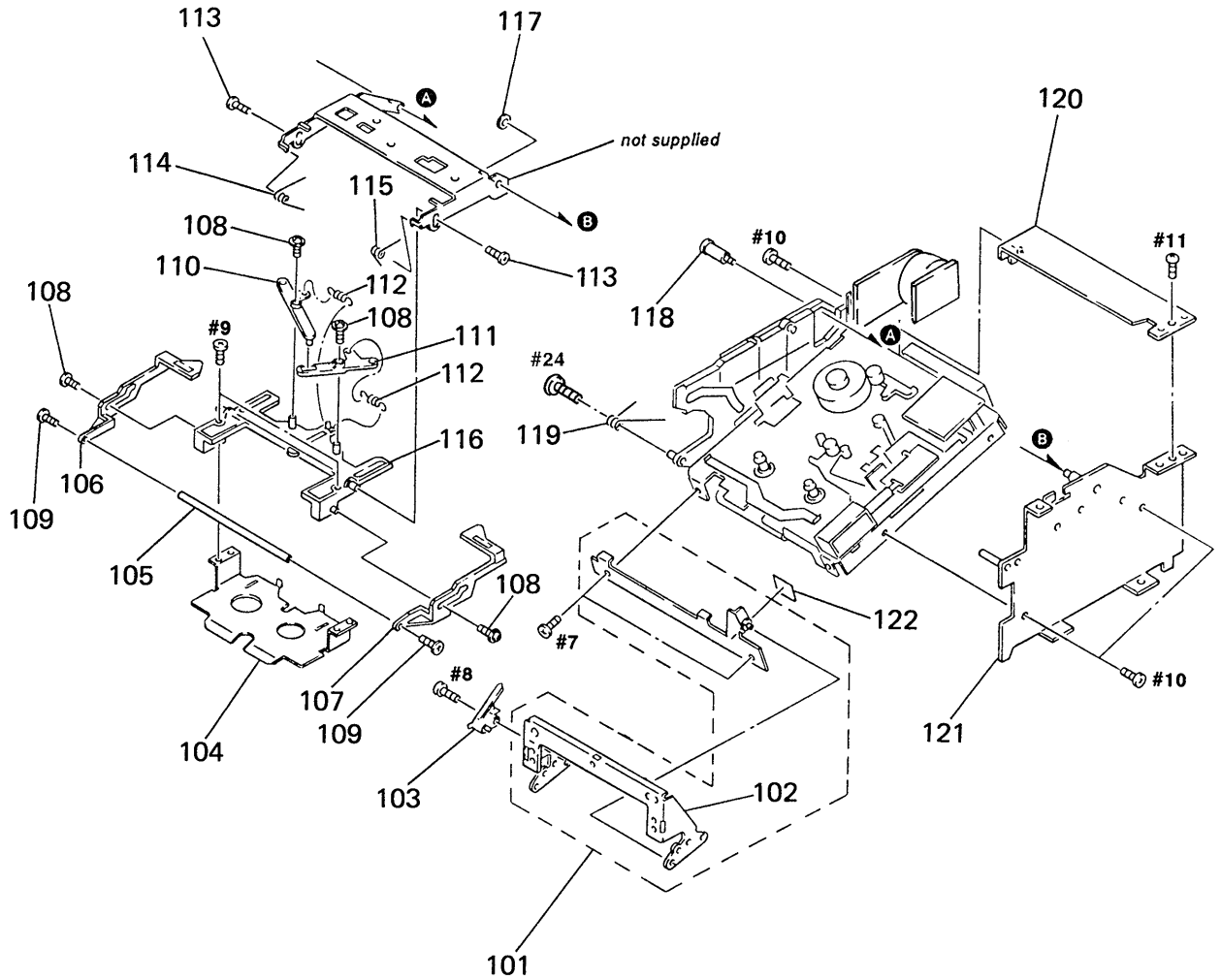

Ref. No.	Part No.	Description	Remark	Ref. No.	Part No.	Description	Remark
* 101	X-3367-635-1	PLATE ASSY, FULCRUM		112	3-632-859-00	SPRING, BRAKE LEVER RETURN	
102	3-373-225-01	HOLDER (WINDOW)		113	3-318-203-61	SCREW (B1.7×4), TAPPING	
103	3-373-220-01	ARM (JOINT)		114	3-373-216-01	SPRING (L), TORSION	
104	3-373-224-01	HOLDER (LOWER)		115	3-373-215-01	SPRING (R), TORSION	
* 105	3-373-217-01	SHAFT (JOINT)		116	3-373-237-03	HOLDER (UPPER), CASSETTE	
106	3-373-223-01	SLIDER (L)		117	3-307-948-21	WASHER, NYLON	
107	3-373-222-01	SLIDER (R)		118	4-931-471-01	SCREW (STEP)	
108	3-318-201-11	SCREW (B) (1.4×3), TAPPING		119	3-373-212-01	SPRING (CASSETTE)	
109	3-345-648-61	SCREW (M1.4), TOOTHED LOCK		* 120	3-909-720-01	REINFORCEMENT	
110	3-373-219-01	LEVER (L)		* 121	X-3367-634-1	PLATE (R) ASSY, SIDE	
111	3-373-218-01	LEVER (R)		122	3-908-780-01	SHEET	

### 6-4. CASSETTE COMPARTMENT SECTION (2)

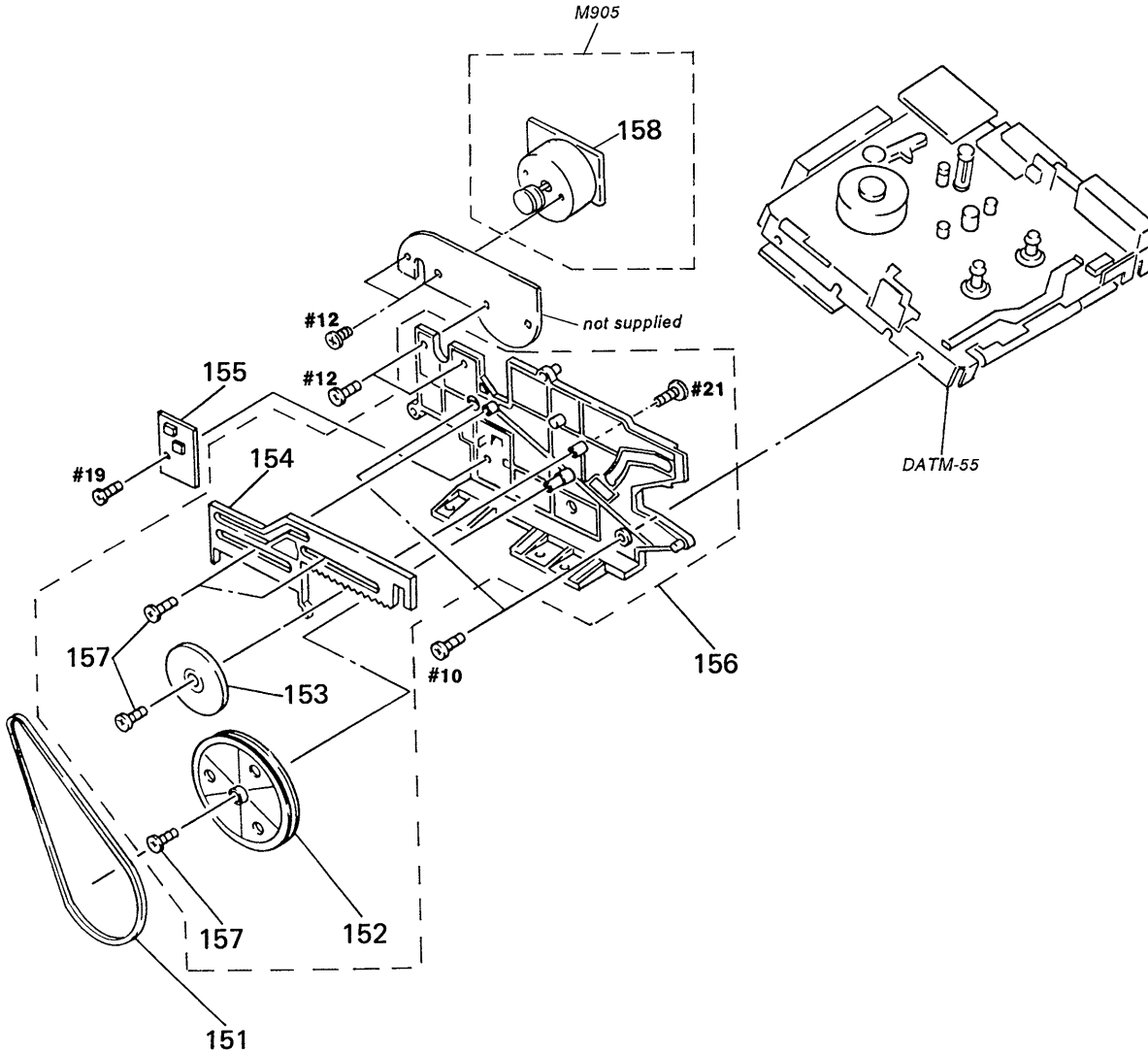

<u>Ref. No.</u>	<u>Part No.</u>	<u>Description</u>	<u>Remark</u>	<u>Ref. No.</u>	<u>Part No.</u>	<u>Description</u>	<u>Remark</u>
151	3-562-462-00	BELT, CAPSTAN		156	A-2003-907-1	CHASSIS (L) ASSY	
152	3-373-214-01	PULLEY		157	2-623-756-01	SCREW, (Bl. 7×3), TAPPING	
153	3-373-213-01	GEAR, DRIVING		* 158	1-655-913-11	MOTOR BOARD	
* 154	X-3364-426-1	SLIDER ASSY		M905	X-3370-655-1	MOTOR ASSY (CASSETTE COMPARTMENT)	
* 155	1-655-916-11	SW BOARD					

6-5. MECHANISM DECK SECTION (1)  
(DATM-55)

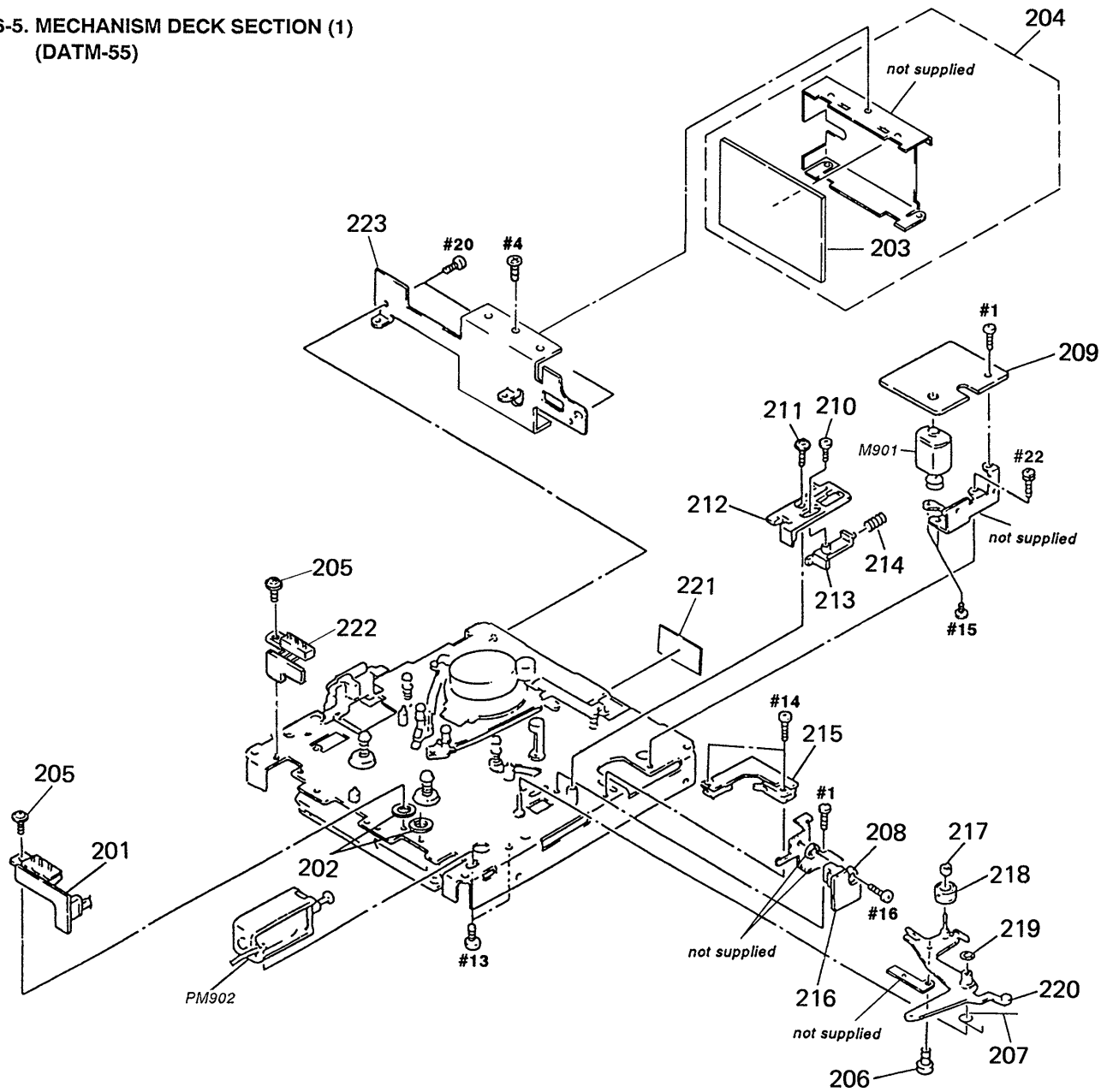

Ref.No.	Part No.	Description	Remark	Ref.No.	Part No.	Description	Remark
* 201	1-654-393-11	REC EN BOARD		214	3-564-035-00	SPRING, COMPRESSION	
202	3-344-781-01	WASHER, POLYETHYLENE		* 215	1-655-285-11	LOAD SW BOARD	
* 203	A-2006-455-A	RF AMP BOARD, COMPLETE		* 216	1-654-391-11	T END BOARD	
* 204	A-2001-587-A	RF COMPLETE ASSY BOARD, COMPLETE		217	3-337-626-01	CAP, PINCH ROLLER	
205	3-321-041-01	SCREW (M1.7×3.5), TAPPING		218	X-3337-610-1	PINCH ROLLER ASSY	
206	3-704-244-01	SCREW (P1.7×1.6)		219	3-701-436-11	WASHER, STOPPER	
207	3-367-352-01	SPRING (PINCH)		220	X-3362-021-1	LEVER (PINCH ROLLER) ASSY	
208	A-2004-299-A	DETECTION (R) ASSY, E		221	3-366-886-01	SHEET (RF BRACKET)	
* 209	1-655-286-11	LOADING MOTOR BOARD		222	1-654-394-12	THICK BOARD	
210	2-623-756-01	SCREW, (Bl. 7×3), TAPPING		* 223	3-929-800-01	BRACKET (RF)	
211	3-703-502-11	SCREW		M901	A-2004-301-A	MOTOR ASSY, CONTROL (LOADING)	
212	3-362-148-01	SLIDER (PINCH)		PM902	1-454-522-11	SOLENOID, PLUNGER	
213	3-362-149-01	SLIDER (LIMITER)					



6-6. MECHANISM DECK SECTION (2)  
(DATM-55)

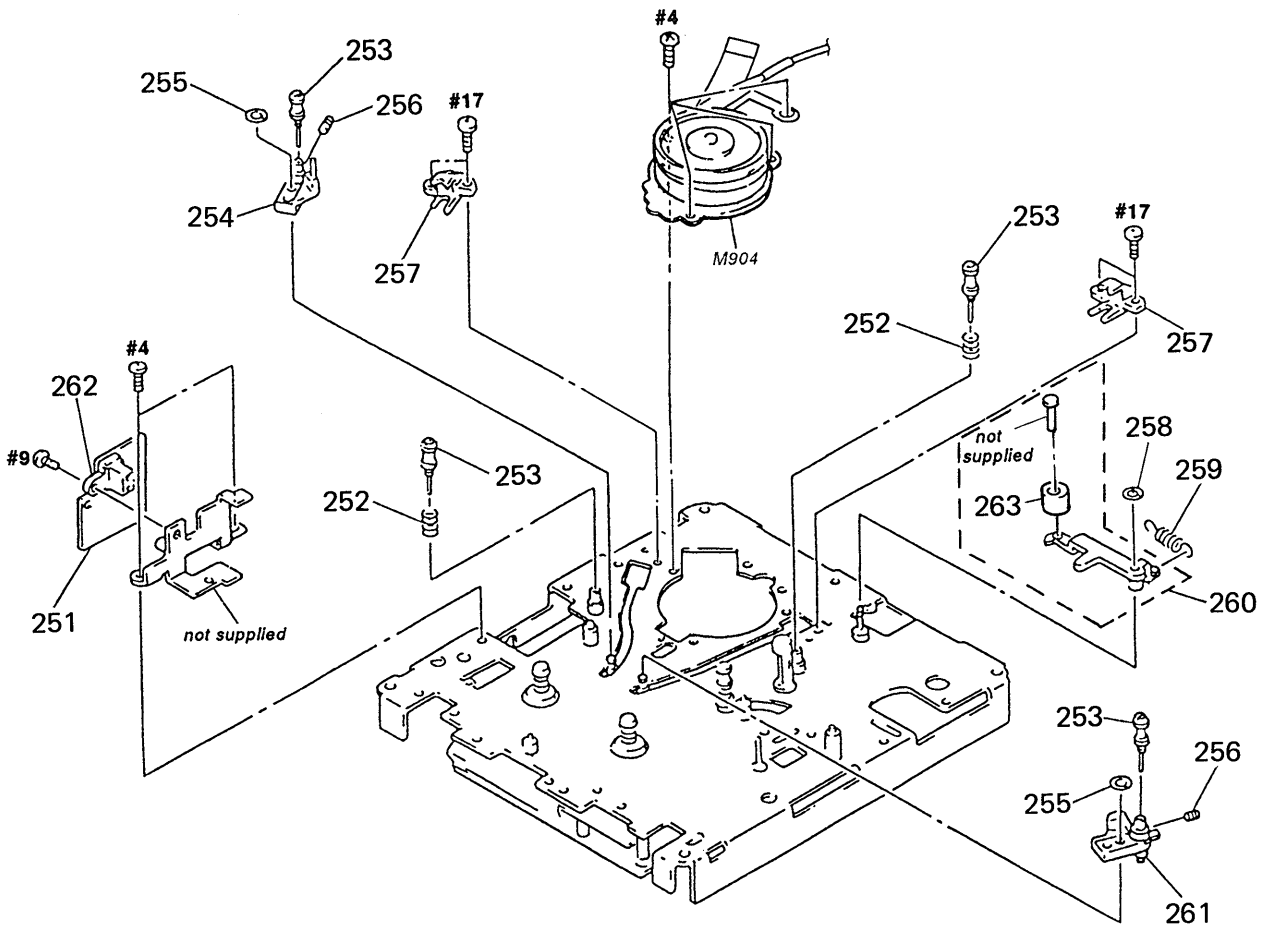

Ref. No.	Part No.	Description	Remark	Ref. No.	Part No.	Description	Remark
* 251	1-654-392-11	S END BOARD		258	3-701-436-11	WASHER, STOPPER	
252	3-573-470-00	SPRING, COMPRESSION		259	3-307-375-00	SPRING, TENSION	
253	X-3337-643-1	GUIDE (RIC) ASSY, ROLLER		260	A-2003-487-A	ARM (CLEANING) ASSY	
254	X-3362-028-1	SLANT BLOCK (L2) ASSY		261	X-3362-029-1	SLANT BLOCK (R2) ASSY	
255	3-341-752-11	WASHER, POLYETHYLENE		262	A-2004-550-A	DETECTION (L) ASSY, E	
256	3-362-152-01	SCREW (RETURN GUIDE BOSS)		263	X-3337-655-1	ROLLER (CLEANER) ASSY	
257	3-912-011-01	CATCHER		M904	8-848-626-11	DRUM ASSY DOU-03D	

6-7. MECHANISM DECK SECTION (3)  
(DATM-55)

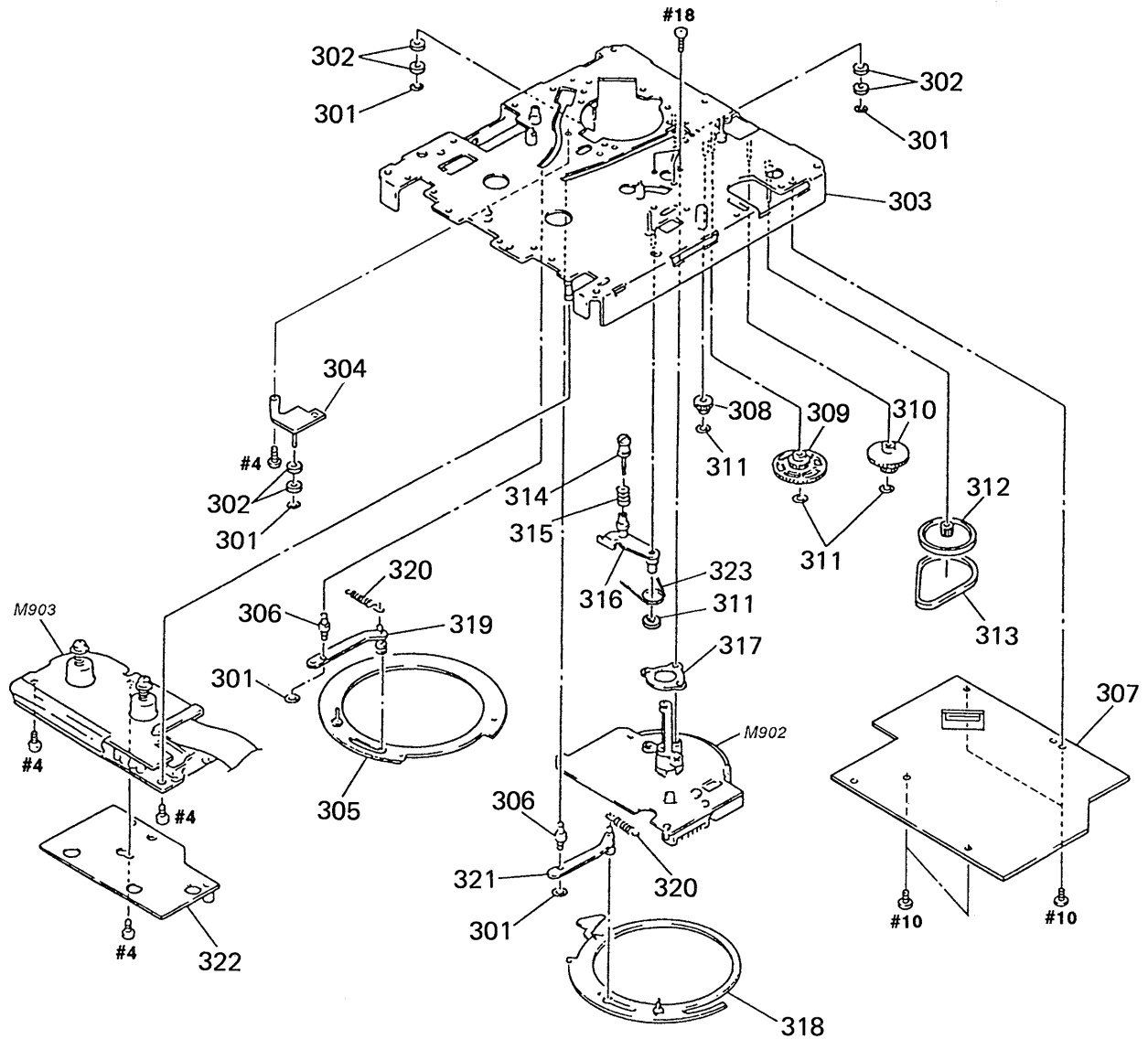

Ref.No.	Part No.	Description	Remark	Ref.No.	Part No.	Description	Remark
301	3-559-408-11	WASHER, POLYETHYLENE, DIA. 1.2		314	X-3337-643-1	GUIDE (RIC) ASSY, ROLLER	
302	3-337-622-01	ROLLER, RING		315	3-573-470-00	SPRING, COMPRESSION	
* 303	X-3362-030-7	CHASSIS ASSY		* 316	X-3362-020-1	LEVER (F GUIDE) ASSY	
304	X-3370-186-1	ARM (RING ROLLER) ASSY		* 317	3-362-156-01	BRACKET (CAPSTAN)	
305	X-3369-705-1	RING (L) ASSY, LOADING		318	X-3362-204-1	GEAR (LOAD) ASSY	
306	3-362-151-01	BOSS (GUIDE)		* 319	X-3362-024-1	LEVER (LOADING L) ASSY	
* 307	A-2007-321-A	DRUM DRIVE BOARD, COMPLETE		320	3-337-653-01	SPRING, TENSION	
308	3-372-619-01	GEAR		* 321	X-3362-025-1	LEVER (LOADING R) ASSY	
309	3-345-181-01	GEAR (LOADING A)		322	3-929-801-01	BRACKET (MD PC BOARD)	
310	3-362-155-01	GEAR (A)		323	3-375-034-01	SPRING (F GUIDE)	
311	3-701-436-11	WASHER, STOPPER		M902	8-835-306-01	MOTOR, DC U-17A (CAPSTAN)	
312	4-932-338-01	PULLEY (A)		* M903	8-835-205-01	MOTOR, DC U-2A (REEL) (including PM901)	
313	4-913-325-01	BELT, TAKE-UP					

## SECTION 7 ELECTRICAL PARTS LIST

**2V REG**

**5V REG**

**6V REG**

**AUDIO**

**NOTE :**

- Due to standardization, replacements in the parts list may be different from the parts specified in the diagrams or the components used on the set.
- -XX, -X mean standardized parts, so they may have some difference from the original one.
- RESISTORS  
All resistors are in ohms  
METAL : Metal-film resistor  
METAL OXIDE : Metal oxide-film resistor  
F : nonflammable

- Items marked " \* " are not stocked since they are seldom required for routine service. Some delay should be anticipated when ordering these items.
- SEMICONDUCTORS  
In each case, u :  $\mu$ , for example :  
uA..... :  $\mu$  A....., uPA..... :  $\mu$  PA.....  
uPB..... :  $\mu$  PB....., uPC..... :  $\mu$  PC.....  
uPD..... :  $\mu$  PD.....
- CAPACITORS  
uF :  $\mu$  F
- COILS  
uH :  $\mu$  H

The components identified by mark  $\Delta$  or dotted line with mark  $\Delta$  are critical for safety. Replace only with part number specified.

When indicating parts by reference number, please include the board.

- Abbreviation  
G : German model

Ref.No.	Part No.	Description	Remark
*	1-655-928-11	2V REG BOARD ***** < CAPACITOR >	
C911	1-162-294-31	CERAMIC	0.001uF 10% 50V
		< TRANSISTOR >	
Q901	8-729-209-15	TRANSISTOR 2SD2012	
*****			
*	1-655-926-11	5V REG BOARD ***** < CAPACITOR >	
C907	1-164-159-11	CERAMIC	0.1uF 50V
C908	1-164-159-11	CERAMIC	0.1uF 50V
		< IC >	
IC901	8-759-144-82	IC uPC2405HF	
*****			
*	1-655-927-11	6V REG BOARD ***** < CAPACITOR >	
C909	1-164-159-11	CERAMIC	0.1uF 50V
C910	1-164-159-11	CERAMIC	0.1uF 50V
		< IC >	
IC902	8-759-148-79	IC uPC2406HF	
*****			
*	A-2007-453-A	AUDIO BOARD, COMPLETE ***** < CAPACITOR >	
C101	1-110-339-11	MYLAR	220PF 5% 50V
C102	1-126-023-11	ELECT	100uF 20% 25V
C103	1-130-482-00	MYLAR	0.0082uF 5% 50V
C104	1-130-481-00	MYLAR	0.0068uF 5% 50V
C105	1-126-023-11	ELECT	100uF 20% 25V

Ref.No.	Part No.	Description	Remark
	C106-109		
	1-136-165-00	FILM	0.1uF 5% 50V
C110	1-106-343-00	MYLAR	1000PF 5% 200V
C111	1-130-467-00	MYLAR	470PF 5% 50V
C112	1-130-467-00	MYLAR	470PF 5% 50V
C113	1-110-339-11	MYLAR	220PF 5% 50V
	C114	1-110-339-11	MYLAR 220PF 5% 50V
	C115	1-106-359-00	MYLAR 4700PF 5% 200V
	C116	1-106-343-00	MYLAR 1000PF 5% 200V
	C117	1-126-365-51	ELECT 100uF 20% 63V
	C118	1-136-165-00	FILM 0.1uF 5% 50V
	C119	1-136-165-00	FILM 0.1uF 5% 50V
	C120	1-110-339-11	MYLAR 220PF 5% 50V
	C123	1-126-023-11	ELECT 100uF 20% 25V
	C140	1-126-024-11	ELECT 220uF 20% 25V
	C201	1-110-339-11	MYLAR 220PF 5% 50V
	C202	1-126-023-11	ELECT 100uF 20% 25V
	C203	1-130-482-00	MYLAR 0.0082uF 5% 50V
	C204	1-130-481-00	MYLAR 0.0068uF 5% 50V
	C205	1-126-023-11	ELECT 100uF 20% 25V
	C206-209		
	1-136-165-00	FILM	0.1uF 5% 50V
	C210	1-106-343-00	MYLAR 1000PF 5% 200V
	C211	1-130-467-00	MYLAR 470PF 5% 50V
	C212	1-130-467-00	MYLAR 470PF 5% 50V
	C213	1-110-339-11	MYLAR 220PF 5% 50V
	C214	1-110-339-11	MYLAR 220PF 5% 50V
	C215	1-106-359-00	MYLAR 4700PF 5% 200V
	C216	1-106-343-00	MYLAR 1000PF 5% 200V
	C217	1-126-365-51	ELECT 100uF 20% 63V
	C218	1-136-165-00	FILM 0.1uF 5% 50V
	C219	1-136-165-00	FILM 0.1uF 5% 50V
	C220	1-110-339-11	MYLAR 220PF 5% 50V
	C223	1-126-023-11	ELECT 100uF 20% 25V
	C240	1-126-024-11	ELECT 220uF 20% 25V
	C301	1-124-997-11	ELECT 470uF 20% 10V
	C302	1-124-997-11	ELECT 470uF 20% 10V
	C303-305		
	1-136-165-00	FILM	0.1uF 5% 50V
	C306	1-126-023-11	ELECT 100uF 20% 25V
	C307	1-136-165-00	FILM 0.1uF 5% 50V

# AUDIO

Ref. No.	Part No.	Description		Remark
C308	1-126-023-11	ELECT	100uF	20% 25V
C309	1-162-294-31	CERAMIC	0.001uF	10% 50V
C310	1-162-294-31	CERAMIC	0.001uF	10% 50V
C311	1-164-159-11	CERAMIC	0.1uF	50V
C312	1-124-997-11	ELECT	470uF	20% 10V
C313	1-136-165-00	FILM	0.1uF	5% 50V
C314	1-164-159-11	CERAMIC	0.1uF	50V
C315	1-162-195-31	CERAMIC	4.7PF	10% 50V
C316	1-162-195-31	CERAMIC	4.7PF	10% 50V
C317	1-162-196-31	CERAMIC	5.6PF	10% 50V
C318	1-162-196-31	CERAMIC	5.6PF	10% 50V
C319	1-164-159-11	CERAMIC	0.1uF	50V
C320	1-137-150-11	ELECT	5600uF	20% 35V
C321	1-137-150-11	ELECT	5600uF	20% 35V
C322	1-136-165-00	FILM	0.1uF	5% 50V
C323	1-136-165-00	FILM	0.1uF	5% 50V
C324	1-126-027-11	ELECT	1000uF	20% 25V
C325	1-126-027-11	ELECT	1000uF	20% 25V
C326	1-124-997-11	ELECT	470uF	20% 10V
C327	1-136-165-00	FILM	0.1uF	5% 50V
C328	1-126-023-11	ELECT	100uF	20% 25V
C329	1-136-165-00	FILM	0.1uF	5% 50V
C330	1-126-023-11	ELECT	100uF	20% 25V
C331	1-136-165-00	FILM	0.1uF	5% 50V
C332	1-136-165-00	FILM	0.1uF	5% 50V
C333	1-126-013-11	ELECT	1000uF	20% 16V
C334	1-162-294-31	CERAMIC	0.001uF	10% 50V
C335	1-162-294-31	CERAMIC	0.001uF	10% 50V
C336	1-164-159-11	CERAMIC	0.1uF	50V
C337	1-164-159-11	CERAMIC	0.1uF	50V
C338	1-126-023-11	ELECT	100uF	20% 25V
C339	1-164-159-11	CERAMIC	0.1uF	50V
C340	1-136-169-00	FILM	0.22uF	5% 50V
C341	1-136-153-00	FILM	0.01uF	5% 50V
C342	1-162-219-31	CERAMIC	68PF	5% 50V
C343	1-162-199-31	CERAMIC	10PF	5% 50V
C344	1-162-199-31	CERAMIC	10PF	5% 50V
C345	1-126-059-11	ELECT	10uF	20% 50V
C346	1-164-159-11	CERAMIC	0.1uF	50V
C347	1-162-215-31	CERAMIC	47PF	5% 50V
C348	1-136-161-00	FILM	0.047uF	5% 50V
C350	1-126-025-11	ELECT	330uF	20% 25V
C351	1-126-025-11	ELECT	330uF	20% 25V
C352	1-164-159-11	CERAMIC	0.1uF	50V
C353	1-164-159-11	CERAMIC	0.1uF	50V
C356	1-164-159-11	CERAMIC	0.1uF	50V
C361	1-136-177-00	FILM	1uF	5% 50V
C362	1-136-165-00	FILM	0.1uF	5% 50V
C364	1-164-159-11	CERAMIC	0.1uF	50V

Ref. No.	Part No.	Description		Remark
C367-370				
	1-164-159-11	CERAMIC	0.1uF	50V
		< CONNECTOR >		
CN301	1-691-771-11	PLUG (MICRO CONNECTOR)	9P	
CN302	1-691-768-31	PLUG (MICRO CONNECTOR)	6P	
CN303	1-691-766-11	PLUG (MICRO CONNECTOR)	4P	
CN304	1-691-768-11	PLUG (MICRO CONNECTOR)	6P	
CN305	1-691-765-11	PLUG (MICRO CONNECTOR)	3P	
CN309	1-568-838-11	SOCKET, CONNECTOR	21P	
CN310	1-691-766-41	PLUG (MICRO CONNECTOR)	4P	
		< DIODE >		
D101-104				
	8-719-987-63	DIODE	1N4148M	
D201-204				
	8-719-987-63	DIODE	1N4148M	
D301-304				
	8-719-230-02	DIODE	30DF2	
D305-307				
	8-719-987-63	DIODE	1N4148M	
D308	8-719-976-30	DIODE	KV1560N	
D313-315				
	8-719-987-63	DIODE	1N4148M	
		< RESISTOR >		
△FR303	1-212-865-00	FUSIBLE	22 5% 1/4W F	
		< IC >		
IC101	8-759-900-72	IC	NE5532P	
IC102	8-759-900-72	IC	NE5532P	
IC201	8-759-900-72	IC	NE5532P	
IC202	8-759-900-72	IC	NE5532P	
IC301	8-759-231-58	IC	TA7812S	
IC302	8-759-245-86	IC	TA7912S	
IC303	8-759-602-83	IC	M5238P	
IC304	8-759-602-83	IC	M5238P	
IC305	8-759-094-53	IC	TA7805S	
IC306	8-759-094-68	IC	TA79005S-LBSONY	
IC307	8-759-330-53	IC	CXD8493M-E1	
IC308	8-759-196-21	IC	CXD8482Q	
IC309	8-759-287-83	IC	SN74HC74ANS-E20	
IC310	8-759-269-92	IC	SN74HCU04ANS-E20	
IC311	8-759-269-92	IC	SN74HCU04ANS-E20	
IC312	8-759-926-95	IC	SN74HC4020NS	
IC313	8-759-270-50	IC	SN74HC368ANS-E20	
IC314	8-759-334-75	IC	CXD8505AQ	
IC315	8-759-250-81	IC	TC5081AP	

The components identified by mark △ or dotted line with mark △ are critical for safety. Replace only with part number specified.

# AUDIO

Ref.No.	Part No.	Description	Remark
IC316-318	8-759-094-53	IC TA7805S	
IC325	8-759-242-72	IC TC7W00F	
< JACK >			
J301	1-770-163-11	JACK, PIN 4P (ANALOG LINE IN/OUT)	
< COIL >			
L302-306	1-410-509-11	INDUCTOR 10uH	
L307	1-426-850-11	COIL (RF)	
L308	1-410-397-21	FERRITE BEAD INDUCTOR	
L309	1-410-397-21	FERRITE BEAD INDUCTOR	
L312	1-410-509-11	INDUCTOR 10uH	
< TERMINAL BOARD >			
LUG301	1-537-770-21	TERMINAL BOARD, GROUND	
LUG302	1-537-770-21	TERMINAL BOARD, GROUND	
LUG304	1-537-770-21	TERMINAL BOARD, GROUND	
< TRANSISTOR >			
Q101	8-729-107-85	TRANSISTOR 2SC3623A-K	
Q102	8-729-107-85	TRANSISTOR 2SC3623A-K	
Q201	8-729-107-85	TRANSISTOR 2SC3623A-K	
Q202	8-729-107-85	TRANSISTOR 2SC3623A-K	
Q301	8-729-900-61	TRANSISTOR DTA114ES	
Q302	8-729-900-80	TRANSISTOR DTC114ES	
Q303	8-729-900-80	TRANSISTOR DTC114ES	
Q304-306	8-729-620-05	TRANSISTOR 2SC2603-EF	
Q307	8-729-200-56	TRANSISTOR 2SK241-GR	
Q308	8-729-200-56	TRANSISTOR 2SK241-GR	
Q309	8-729-900-61	TRANSISTOR DTA114ES	
Q310-313	8-729-900-80	TRANSISTOR DTC114ES	
Q314	8-729-900-61	TRANSISTOR DTA114ES	
Q315	8-729-900-80	TRANSISTOR DTC114ES	
< RESISTOR >			
R102	1-249-441-11	CARBON 100K 5%	1/4W
R103	1-249-429-11	CARBON 10K 5%	1/4W
R104	1-249-420-11	CARBON 1.8K 5%	1/4W
R105	1-247-903-00	CARBON 1M 5%	1/4W
R106	1-249-425-11	CARBON 4.7K 5%	1/4W
R107	1-249-437-11	CARBON 47K 5%	1/4W
R108	1-249-425-11	CARBON 4.7K 5%	1/4W
R109	1-249-425-11	CARBON 4.7K 5%	1/4W
R110	1-249-401-11	CARBON 47 5%	1/4W
R111	1-249-401-11	CARBON 47 5%	1/4W

Ref.No.	Part No.	Description	Remark
R112-115	1-249-425-11	CARBON 4.7K 5%	1/4W
R116	1-249-419-11	CARBON 1.5K 5%	1/4W
R117	1-249-419-11	CARBON 1.5K 5%	1/4W
R118	1-249-425-11	CARBON 4.7K 5%	1/4W
R119	1-249-425-11	CARBON 4.7K 5%	1/4W
R120-123	1-249-421-11	CARBON 2.2K 5%	1/4W
R124	1-249-419-11	CARBON 1.5K 5%	1/4W
R125	1-249-419-11	CARBON 1.5K 5%	1/4W
R126	1-249-441-11	CARBON 100K 5%	1/4W
R127	1-249-782-11	CARBON 150 5%	1/6W
R128	1-249-782-11	CARBON 150 5%	1/6W
R129	1-249-429-11	CARBON 10K 5%	1/4W
R130	1-249-782-11	CARBON 150 5%	1/6W
R202	1-249-441-11	CARBON 100K 5%	1/4W
R203	1-249-429-11	CARBON 10K 5%	1/4W
R204	1-249-420-11	CARBON 1.8K 5%	1/4W
R205	1-247-903-00	CARBON 1M 5%	1/4W
R206	1-249-425-11	CARBON 4.7K 5%	1/4W
R207	1-249-437-11	CARBON 47K 5%	1/4W
R208	1-249-425-11	CARBON 4.7K 5%	1/4W
R209	1-249-425-11	CARBON 4.7K 5%	1/4W
R210	1-249-401-11	CARBON 47 5%	1/4W
R211	1-249-401-11	CARBON 47 5%	1/4W
R212-215	1-249-425-11	CARBON 4.7K 5%	1/4W
R216	1-249-419-11	CARBON 1.5K 5%	1/4W
R217	1-249-419-11	CARBON 1.5K 5%	1/4W
R218	1-249-425-11	CARBON 4.7K 5%	1/4W
R219	1-249-425-11	CARBON 4.7K 5%	1/4W
R220-223	1-249-421-11	CARBON 2.2K 5%	1/4W
R224	1-249-419-11	CARBON 1.5K 5%	1/4W
R225	1-249-419-11	CARBON 1.5K 5%	1/4W
R226	1-249-441-11	CARBON 100K 5%	1/4W
R227	1-249-782-11	CARBON 150 5%	1/6W
R228	1-249-782-11	CARBON 150 5%	1/6W
R229	1-249-429-11	CARBON 10K 5%	1/4W
R230	1-249-782-11	CARBON 150 5%	1/6W
R301	1-249-437-11	CARBON 47K 5%	1/4W
R302	1-249-441-11	CARBON 100K 5%	1/4W
R303	1-249-429-11	CARBON 10K 5%	1/4W
R304-309	1-249-413-11	CARBON 470 5%	1/4W
R310	1-249-441-11	CARBON 100K 5%	1/4W
R311	1-249-417-11	CARBON 1K 5%	1/4W
R312	1-247-903-00	CARBON 1M 5%	1/4W
R313	1-249-782-11	CARBON 150 5%	1/6W
R314	1-249-441-11	CARBON 100K 5%	1/4W

**AUDIO**

**CONTROL SW**

**DIGITAL**

Ref. No.	Part No.	Description	Remark		
R315	1-249-417-11	CARBON	1K	5%	1/4W
R316	1-247-903-00	CARBON	1M	5%	1/4W
R317	1-249-782-11	CARBON	150	5%	1/6W
R320	1-247-807-31	CARBON	100	5%	1/4W
R321	1-249-413-11	CARBON	470	5%	1/4W
R322	1-249-441-11	CARBON	100K	5%	1/4W
R323-325					
	1-249-409-11	CARBON	220	5%	1/4W
R326	1-249-413-11	CARBON	470	5%	1/4W
R327	1-249-413-11	CARBON	470	5%	1/4W
R328	1-249-425-11	CARBON	4.7K	5%	1/4W
R329	1-249-417-11	CARBON	1K	5%	1/4W
R330	1-249-401-11	CARBON	47	5%	1/4W
R331	1-249-417-11	CARBON	1K	5%	1/4W
R332	1-249-429-11	CARBON	10K	5%	1/4W
R333	1-249-421-11	CARBON	2.2K	5%	1/4W
R334	1-249-429-11	CARBON	10K	5%	1/4W
R335	1-249-429-11	CARBON	10K	5%	1/4W
R336	1-249-428-11	CARBON	8.2K	5%	1/4W
R337	1-249-441-11	CARBON	100K	5%	1/4W
R338-340					
	1-249-417-11	CARBON	1K	5%	1/4W
R341	1-247-895-00	CARBON	470K	5%	1/4W
R342	1-249-437-11	CARBON	47K	5%	1/4W
R343	1-249-441-11	CARBON	100K	5%	1/4W
R345	1-249-429-11	CARBON	10K	5%	1/4W
R350	1-249-409-11	CARBON	220	5%	1/4W
R351	1-249-409-11	CARBON	220	5%	1/4W
R353	1-249-417-11	CARBON	1K	5%	1/4W
R354	1-249-417-11	CARBON	1K	5%	1/4W
< RELAY >					
RY301	1-515-726-11	RELAY			
< VIBRATOR >					
X301	1-567-814-11	VIBRATOR, CRYSTAL (24.576MHz)			
X302	1-567-815-11	VIBRATOR, CRYSTAL (22.5972MHz)			
*****					
*	1-658-920-11	CONTROL SW BOARD			
*****					
< DIODE >					
D701	8-719-055-66	LED SEL2410G-TP6 (▶)			
D702	8-719-055-65	LED SEL2810D-TP6 (▬)			
D703	8-719-300-71	LED SEL2210R (●REC)			
< RESISTOR >					
R709	1-249-415-11	CARBON	680	5%	1/4W

Ref. No.	Part No.	Description	Remark		
R710	1-249-417-11	CARBON	1K	5%	1/4W
R713	1-249-417-11	CARBON	1K	5%	1/4W
R714	1-249-419-11	CARBON	1.5K	5%	1/4W
R715	1-249-423-11	CARBON	3.3K	5%	1/4W
< SWITCH >					
S701	1-554-937-11	SWITCH, KEY BOARD (≡ OPEN/CLOSE)			
S702	1-554-937-11	SWITCH, KEY BOARD (■)			
S703	1-554-937-11	SWITCH, KEY BOARD (▶)			
S707	1-554-937-11	SWITCH, KEY BOARD (●REC)			
S708	1-554-937-11	SWITCH, KEY BOARD (▬)			
S709	1-554-937-11	SWITCH, KEY BOARD (○REC MUTE)			
*****					
*	A-2007-454-A	DIGITAL BOARD, COMPLETE			
*****					
	1-533-293-11	FUSE HOLDER			
< CAPACITOR >					
C501	1-126-017-11	ELECT	6800uF	20%	16V
C502	1-126-946-11	ELECT	6800uF	20%	25V
C503	1-126-927-11	ELECT	2200uF	20%	10V
C504	1-124-473-11	ELECT	1000uF	20%	10V
C505	1-124-472-11	ELECT	470uF	20%	10V
C506	1-124-472-11	ELECT	470uF	20%	10V
C507	1-164-159-11	CERAMIC	0.1uF		50V
C508	1-124-919-11	ELECT	220uF	20%	63V
C509	1-124-122-11	ELECT	100uF	20%	50V
C510	1-164-159-11	CERAMIC	0.1uF		50V
C511	1-164-159-11	CERAMIC	0.1uF		50V
C512	1-162-294-31	CERAMIC	0.001uF	10%	50V
C513	1-162-302-11	CERAMIC	0.0022uF	30%	16V
C514	1-162-286-31	CERAMIC	220PF	10%	50V
C515	1-162-294-31	CERAMIC	0.001uF	10%	50V
C516	1-162-302-11	CERAMIC	0.0022uF	30%	16V
C517	1-162-286-31	CERAMIC	220PF	10%	50V
C518	1-162-306-11	CERAMIC	0.01uF	20%	16V
C519	1-162-306-11	CERAMIC	0.01uF	20%	16V
C520	1-162-290-31	CERAMIC	470PF	10%	50V
C521	1-162-306-11	CERAMIC	0.01uF	20%	16V
C522	1-126-965-11	ELECT	22uF	20%	50V
C523	1-162-306-11	CERAMIC	0.01uF	20%	16V
C524	1-162-290-31	CERAMIC	470PF	10%	50V
C525	1-162-306-11	CERAMIC	0.01uF	20%	16V
C526	1-126-965-11	ELECT	22uF	20%	50V
C527	1-164-159-11	CERAMIC	0.1uF		50V
C528	1-164-159-11	CERAMIC	0.1uF		50V
C529	1-124-442-00	ELECT	330uF	20%	6.3V
C530	1-162-294-31	CERAMIC	0.001uF	10%	50V

# DIGITAL

Ref. No.	Part No.	Description	Remark	Ref. No.	Part No.	Description	Remark
C531	1-126-961-11	ELECT	2. 2uF 20%	CN507	1-691-461-11	PIN, CONNECTOR (PC BOARD) 5P	
C532	1-164-159-11	CERAMIC	0. 1uF 50V	* CN508	1-564-339-00	PIN, CONNECTOR 5P	
C533	1-162-203-31	CERAMIC	15PF 5%	CN509	1-691-765-31	PLUG (MICRO CONNECTOR) 3P	
C534	1-162-203-31	CERAMIC	15PF 5%	CN510	1-691-765-41	PLUG (MICRO CONNECTOR) 3P	
C535	1-164-159-11	CERAMIC	0. 1uF 50V	CN511	1-691-765-21	PLUG (MICRO CONNECTOR) 3P	
C536	1-136-165-00	FILM	0. 1uF 5%	CN514	1-568-838-11	SOCKET, CONNECTOR 21P	
C537	1-124-442-00	ELECT	330uF 20%	* CN516	1-564-336-00	PIN, CONNECTOR 2P	
C538	1-164-159-11	CERAMIC	0. 1uF 50V	< DIODE >			
C539	1-162-306-11	CERAMIC	0. 01uF 20%	D501	8-719-312-47	DIODE RBA-406B	
C540	1-162-294-31	CERAMIC	0. 001uF 10%	D502	8-719-312-47	DIODE RBA-406B	
C541	1-162-284-31	CERAMIC	150PF 10%	D503	8-719-200-77	DIODE 10E2N	
C542	1-164-159-11	CERAMIC	0. 1uF 50V	D504	8-719-015-13	DIODE UZP-9. 1BC-TP	
C543	1-124-442-00	ELECT	330uF 20%	D505	8-719-200-77	DIODE 10E2N	
C544-549	1-162-294-31	CERAMIC	0. 001uF 10%	D506	8-719-200-77	DIODE 10E2N	
C550	1-164-159-11	CERAMIC	0. 1uF 50V	D507	8-719-985-57	DIODE HZS4BLL-TA	
C552	1-162-207-31	CERAMIC	22PF 5%	D508	8-719-987-63	DIODE 1N4148M	
C553	1-162-207-31	CERAMIC	22PF 5%	D509	8-719-987-63	DIODE 1N4148M	
C554	1-162-203-31	CERAMIC	15PF 5%	D510	8-719-200-77	DIODE 10E2N	
C555	1-162-203-31	CERAMIC	15PF 5%	D511	8-719-911-06	DIODE 1SS106	
C556-558	1-164-159-11	CERAMIC	0. 1uF 50V	D512	8-719-911-06	DIODE 1SS106	
C559	1-136-153-00	FILM	0. 01uF 5%	D513	8-719-045-72	DIODE KV1550NT	
C560	1-164-159-11	CERAMIC	0. 1uF 50V	< FUSE >			
C561	1-162-211-31	CERAMIC	33PF 5%	△F501	1-532-286-00	FUSE (T2. 5A 250V)	
C562	1-136-153-00	FILM	0. 01uF 5%	△F502	1-532-286-00	FUSE (T2. 5A 250V)	
C563	1-124-907-11	ELECT	10uF 20%	< RESISTOR >			
C564	1-136-153-00	FILM	0. 01uF 5%	△FR501	1-219-136-11	FUSIBLE 0. 22 10% 1/4W F	
C565	1-162-282-31	CERAMIC	100PF 10%	△FR502	1-212-873-11	FUSIBLE 47 5% 1/4W F	
C566-568	1-164-159-11	CERAMIC	0. 1uF 50V	< IC >			
C573	1-162-179-11	CERAMIC	0. 1uF 50V	IC501	8-752-867-23	IC CXP87532-017Q	
C575	1-164-159-11	CERAMIC	0. 1uF 50V	IC502	8-752-867-79	IC CXP87532-019Q	
C576	1-164-159-11	CERAMIC	0. 1uF 50V	IC503	8-752-355-55	IC CXD2605Q	
C578	1-164-159-11	CERAMIC	0. 1uF 50V	IC504	8-752-337-79	IC CXK58257AM-10LL	
C579	1-164-159-11	CERAMIC	0. 1uF 50V	IC505	8-759-281-29	IC YM3412B-F	
C580	1-162-203-31	CERAMIC	15PF 5%	IC506	8-759-242-84	IC TORX176 (DIGITAL OPTICAL IN)	
C581	1-162-205-31	CERAMIC	18PF 5%	IC507	8-759-242-85	IC TOTX176 (DIGITAL OPTICAL OUT)	
C582	1-164-159-11	CERAMIC	0. 1uF 50V	IC508	8-759-256-59	IC HD74HC00FPEL	
C583	1-162-600-11	CERAMIC	0. 0047uF 20%	IC509	8-759-983-69	IC LM358PS	
C584	1-162-600-11	CERAMIC	0. 0047uF 20%	IC510	8-759-256-59	IC HD74HC00FPEL	
C585	1-162-294-31	CERAMIC	0. 001uF 10%	IC511	8-759-926-17	IC SN74HC153ANS	
< CONNECTOR >				IC512	8-759-007-80	IC MC74HC175F	
CN501	1-691-767-11	PLUG (MICRO CONNECTOR) 5P		IC513	8-759-269-92	IC SN74HC04ANS-E20	
CN502	1-691-766-11	PLUG (MICRO CONNECTOR) 4P		IC514	8-759-256-59	IC HD74HC00FPEL	
* CN504	1-568-845-11	SOCKET, CONNECTOR 31P		IC515	8-759-256-59	IC HD74HC00FPEL	
* CN505	1-568-836-11	SOCKET, CONNECTOR 17P		IC516	8-759-634-43	IC M51953BFP	
CN506	1-770-164-11	PIN, CONNECTOR (PC BOARD) 15P					

The components identified by mark  $\triangle$  or dotted line with mark  $\triangle$  are critical for safety. Replace only with part number specified.

Ref. No.	Part No.	Description	Remark
IC517	8-759-333-79	IC AT24C01A-10SC-TP	
IC518	8-759-333-82	IC MSM6782-01MS-K-R1	
IC519	8-759-287-83	IC SN74HC74ANS-E20	
IC520	8-759-983-69	IC LM358PS	
IC521	8-759-983-69	IC LM358PS	
IC522	8-759-983-69	IC LM358PS	
IC523	8-759-633-65	IC M54641L	
< JACK >			
J501	1-770-162-11	JACK, PIN 2P (DIGITAL COAXIAL IN/OUT)	
< COIL >			
L501-503			
	1-410-509-11	INDUCTOR	10uH
L504	1-410-498-11	INDUCTOR	1. 2uH
L505	1-410-509-11	INDUCTOR	10uH
L506	1-410-509-11	INDUCTOR	10uH
< TERMINAL BOARD >			
LUG501	1-537-770-21	TERMINAL BOARD, GROUND	
LUG503	1-537-770-21	TERMINAL BOARD, GROUND	
< TRANSISTOR >			
Q501	8-729-620-05	TRANSISTOR	2SC2603-EF
Q502	8-729-119-76	TRANSISTOR	2SA1175-HFE
Q503	8-729-140-97	TRANSISTOR	2SB734-34
Q504	8-729-927-11	TRANSISTOR	2SA1585SQR
Q505	8-729-927-12	TRANSISTOR	2SC4115SQR
Q506	8-729-927-11	TRANSISTOR	2SA1585SQR
Q507	8-729-927-12	TRANSISTOR	2SC4115SQR
Q508-511	8-729-900-80	TRANSISTOR	DTC114ES
Q512	8-729-141-83	TRANSISTOR	2SB1094-LK
Q513	8-729-119-76	TRANSISTOR	2SA1175-HFE
Q514	8-729-620-05	TRANSISTOR	2SC2603-EF
Q515	8-729-141-83	TRANSISTOR	2SB1094-LK
Q516	8-729-119-76	TRANSISTOR	2SA1175-HFE
Q517-519	8-729-620-05	TRANSISTOR	2SC2603-EF
Q520	8-729-900-80	TRANSISTOR	DTC114ES
Q521	8-729-620-05	TRANSISTOR	2SC2603-EF
Q522	8-729-900-80	TRANSISTOR	DTC114ES
< RESISTOR >			
R501	1-249-425-11	CARBON	4. 7K 5% 1/4W
R502	1-249-429-11	CARBON	10K 5% 1/4W
R503	1-249-421-11	CARBON	2. 2K 5% 1/4W
R504	1-249-433-11	CARBON	22K 5% 1/4W
R505	1-249-423-11	CARBON	3. 3K 5% 1/4W

Ref. No.	Part No.	Description	Remark
R506	1-249-413-11	CARBON	470 5% 1/4W
R507	1-249-429-11	CARBON	10K 5% 1/4W
R508-511	1-249-409-11	CARBON	220 5% 1/4W
R512-520	1-249-441-11	CARBON	100K 5% 1/4W
R522	1-249-441-11	CARBON	100K 5% 1/4W
R523	1-249-441-11	CARBON	100K 5% 1/4W
R524	1-249-429-11	CARBON	10K 5% 1/4W
R525	1-249-417-11	CARBON	1K 5% 1/4W
R526	1-249-429-11	CARBON	10K 5% 1/4W
R527	1-247-807-31	CARBON	100 5% 1/4W
R528	1-249-417-11	CARBON	1K 5% 1/4W
R529	1-249-409-11	CARBON	220 5% 1/4W
R530	1-249-441-11	CARBON	100K 5% 1/4W
R531	1-249-441-11	CARBON	100K 5% 1/4W
R532	1-249-429-11	CARBON	10K 5% 1/4W
R533	1-249-417-11	CARBON	1K 5% 1/4W
R534	1-249-429-11	CARBON	10K 5% 1/4W
R535	1-247-807-31	CARBON	100 5% 1/4W
R536	1-249-417-11	CARBON	1K 5% 1/4W
R537	1-249-409-11	CARBON	220 5% 1/4W
R539	1-249-409-11	CARBON	220 5% 1/4W
R540	1-249-409-11	CARBON	220 5% 1/4W
R541	1-249-441-11	CARBON	100K 5% 1/4W
R542	1-249-441-11	CARBON	100K 5% 1/4W
R544	1-249-441-11	CARBON	100K 5% 1/4W
R545-547	1-249-429-11	CARBON	10K 5% 1/4W
R548-550	1-249-441-11	CARBON	100K 5% 1/4W
R552	1-249-429-11	CARBON	10K 5% 1/4W
R553	1-249-425-11	CARBON	4. 7K 5% 1/4W
R554	1-249-425-11	CARBON	4. 7K 5% 1/4W
R555	1-249-429-11	CARBON	10K 5% 1/4W
R556	1-249-429-11	CARBON	10K 5% 1/4W
R557-562	1-249-441-11	CARBON	100K 5% 1/4W
R563-565	1-249-429-11	CARBON	10K 5% 1/4W
R566	1-249-417-11	CARBON	1K 5% 1/4W
R567-570	1-249-429-11	CARBON	10K 5% 1/4W
R571-573	1-247-807-31	CARBON	100 5% 1/4W
R574	1-249-441-11	CARBON	100K 5% 1/4W
R575-578	1-249-429-11	CARBON	10K 5% 1/4W
R581	1-249-441-11	CARBON	100K 5% 1/4W
R583	1-249-425-11	CARBON	4. 7K 5% 1/4W



# DIGITAL DISPLAY

Ref. No.	Part No.	Description	Remark
R584-591			
	1-249-441-11	CARBON	100K 5% 1/4W
R593	1-249-417-11	CARBON	1K 5% 1/4W
R594	1-249-421-11	CARBON	2. 2K 5% 1/4W
R595	1-249-417-11	CARBON	1K 5% 1/4W
R596	1-249-429-11	CARBON	10K 5% 1/4W
R597	1-249-441-11	CARBON	100K 5% 1/4W
R598	1-249-441-11	CARBON	100K 5% 1/4W
R600-602			
	1-249-425-11	CARBON	4. 7K 5% 1/4W
R603	1-249-413-11	CARBON	470 5% 1/4W
R604	1-249-433-11	CARBON	22K 5% 1/4W
R605	1-249-433-11	CARBON	22K 5% 1/4W
R606	1-249-409-11	CARBON	220 5% 1/4W
R607	1-249-431-11	CARBON	15K 5% 1/4W
R608	1-249-417-11	CARBON	1K 5% 1/4W
R611	1-249-409-11	CARBON	220 5% 1/4W
R612	1-249-437-11	CARBON	47K 5% 1/4W
R613	1-249-429-11	CARBON	10K 5% 1/4W
R614	1-249-429-11	CARBON	10K 5% 1/4W
R615	1-247-807-31	CARBON	100 5% 1/4W
R616	1-249-429-11	CARBON	10K 5% 1/4W
R617	1-249-435-11	CARBON	33K 5% 1/4W
R618	1-249-421-11	CARBON	2. 2K 5% 1/4W
R619	1-249-421-11	CARBON	2. 2K 5% 1/4W
R620	1-247-807-31	CARBON	100 5% 1/4W
R621	1-247-804-11	CARBON	75 5% 1/4W
R622	1-249-429-11	CARBON	10K 5% 1/4W
R623	1-249-429-11	CARBON	10K 5% 1/4W
R624	1-249-427-11	CARBON	6. 8K 5% 1/4W
R625-629			
	1-249-429-11	CARBON	10K 5% 1/4W
R634	1-249-423-11	CARBON	3. 3K 5% 1/4W
R635	1-249-423-11	CARBON	3. 3K 5% 1/4W
R636	1-249-423-11	CARBON	3. 3K 5% 1/4W
R637	1-249-429-11	CARBON	10K 5% 1/4W
R638	1-249-429-11	CARBON	10K 5% 1/4W
R639	1-247-804-11	CARBON	75 5% 1/4W
R645	1-249-413-11	CARBON	470 5% 1/4W
R648	1-247-807-31	CARBON	100 5% 1/4W
		< VARIABLE RESISTOR >	
RV501	1-241-763-11	RES, ADJ, CARBON 4.7K (T END)	
RV502	1-241-763-11	RES, ADJ, CARBON 4.7K (S END)	
		< TRANSFORMER >	
T501	1-409-594-11	COIL (WITH CORE)	

Ref. No.	Part No.	Description	Remark
		< VIBRATOR >	
X501	1-567-814-11	VIBRATOR, CRYSTAL (24.576MHz)	
X502	1-567-816-11	VIBRATOR, CRYSTAL (18.816MHz)	
X503	1-567-098-41	VIBRATOR, CRYSTAL (32.768kHz)	
*****			
*	A-2007-452-A	DISPLAY BOARD, COMPLETE	
*****			
		< CAPACITOR >	
C701	1-126-177-11	ELECT	100uF 20% 10V
C702	1-164-159-11	CERAMIC	0. 1uF 50V
C703	1-162-294-31	CERAMIC	0. 001uF 10% 50V
C706	1-164-159-11	CERAMIC	0. 1uF 50V
C710	1-162-306-11	CERAMIC	0. 01uF 20% 16V
C711	1-162-306-11	CERAMIC	0. 01uF 20% 16V
		< CONNECTOR >	
CN701	1-568-860-11	SOCKET, CONNECTOR 17P	
CN702	1-691-466-11	PIN, CONNECTOR (PC BOARD) 10P	
		< COMPOSITION CIRCUIT BLOCK >	
CP701-704			
	1-233-276-11	COMPOSITION CIRCUIT BLOCK	
		< INDICATOR TUBE >	
FL701	1-517-382-11	INDICATOR TUBE, FLUORESCENT	
		< IC >	
IC701	8-752-869-39	IC CXP82316-061Q	
IC702	8-759-995-09	IC MSM6338RS	
		< LEAD >	
* LD701	1-690-880-31	LEAD (WITH CONNECTOR)	
		< TRANSISTOR >	
Q701-703			
	8-729-620-05	TRANSISTOR	2SC2603-EF
Q704-706			
	8-729-900-80	TRANSISTOR	DTC114ES
		< RESISTOR >	
R701-708			
	1-249-427-11	CARBON	6. 8K 5% 1/4W
R712	1-249-415-11	CARBON	680 5% 1/4W
R717	1-249-415-11	CARBON	680 5% 1/4W
R718	1-249-417-11	CARBON	1K 5% 1/4W
R719	1-249-419-11	CARBON	1. 5K 5% 1/4W

# DISPLAY

# DRUM DRIVE

Ref. No.	Part No.	Description	Remark		
R720	1-249-423-11	CARBON	3.3K	5%	1/4W
R721	1-249-425-11	CARBON	4.7K	5%	1/4W
R722	1-249-429-11	CARBON	10K	5%	1/4W
R723	1-249-415-11	CARBON	680	5%	1/4W
R724	1-249-417-11	CARBON	1K	5%	1/4W
R729	1-249-415-11	CARBON	680	5%	1/4W
R752	1-249-435-11	CARBON	33K	5%	1/4W
R753	1-249-429-11	CARBON	10K	5%	1/4W
R756	1-249-415-11	CARBON	680	5%	1/4W
R757	1-249-435-11	CARBON	33K	5%	1/4W
R760-762					
	1-249-409-11	CARBON	220	5%	1/4W
		< SWITCH >			
S705	1-554-937-11	SWITCH, KEY BOARD (◀◀)			
S706	1-554-937-11	SWITCH, KEY BOARD (▶▶)			
S711	1-554-937-11	SWITCH, KEY BOARD (AUTO)			
S712	1-554-937-11	SWITCH, KEY BOARD (RENUMBER)			
S713	1-554-937-11	SWITCH, KEY BOARD (REHEASAL)			
S714	1-554-937-11	SWITCH, KEY BOARD (START ID WRITE)			
S715	1-554-937-11	SWITCH, KEY BOARD (START ID ERASE)			
S716	1-572-268-11	SWITCH, SLIDE (TIMER)			
S717	1-554-937-11	SWITCH, KEY BOARD (MODE)			
S718	1-554-937-11	SWITCH, KEY BOARD (RESET)			
S719	1-554-937-11	SWITCH, KEY BOARD (CLOCK SET)			
S721	1-554-937-11	SWITCH, KEY BOARD (AMS[KK])			
S722	1-554-937-11	SWITCH, KEY BOARD (AMS[JJ])			
		< VIBRATOR >			
X701	1-577-359-21	VIBRATOR, CERAMIC (4.19MHz)			
*****					
*	A-2007-321-A	DRUM DRIVE BOARD, COMPLETE			
		*****			
	1-537-770-21	TERMINAL BOARD, GROUND			
		< CAPACITOR >			
C1	1-124-257-00	ELECT	2.2uF	20%	50V
C3	1-162-306-11	CERAMIC	0.01uF	20%	16V
C5	1-126-923-11	ELECT	220uF	20%	10V
C6	1-126-923-11	ELECT	220uF	20%	10V
C7	1-126-923-11	ELECT	220uF	20%	10V
C8	1-162-302-11	CERAMIC	0.0022uF	30%	16V
C9	1-162-302-11	CERAMIC	0.0022uF	30%	16V
C10	1-162-286-31	CERAMIC	220PF	10%	50V
C11	1-162-302-11	CERAMIC	0.0022uF	30%	16V
C12	1-162-302-11	CERAMIC	0.0022uF	30%	16V
C13	1-126-096-11	ELECT	10uF	20%	35V

Ref. No.	Part No.	Description	Remark		
C14	1-126-923-11	ELECT	220uF	20%	10V
C15	1-162-306-11	CERAMIC	0.01uF	20%	16V
		< CONNECTOR >			
* CN1	1-568-845-11	SOCKET, CONNECTOR 31P			
CN2	1-691-461-11	PIN, CONNECTOR (PC BOARD) 5P			
CN3	1-564-505-11	PLUG, CONNECTOR 2P			
CN3	1-764-325-11	PIN, CONNECTOR (PCB) (V TYPE) 2P			
* CN4	1-564-704-11	PIN, CONNECTOR (SMALL TYPE) 2P			
* CN5	1-564-515-11	PLUG, CONNECTOR 12P			
* CN6	1-691-465-11	PIN, CONNECTOR (PC BOARD) 9P			
* CN7	1-568-369-11	HOUSING, CONNECTOR (PC BOARD) 8P			
* CN8	1-506-503-11	PIN, CONNECTOR 9P			
* CN9	1-564-337-00	PIN, CONNECTOR 3P			
* CN11	1-564-337-61	PIN, CONNECTOR 3P			
* CN12	1-564-336-00	PIN, CONNECTOR 2P			
		< DIODE >			
D2	8-719-200-82	DIODE 11ES2			
D3	8-719-200-82	DIODE 11ES2			
		< IC >			
IC1	8-759-135-80	IC uPC358C			
IC2	8-759-633-65	IC M54641L			
IC3	8-752-060-73	IC CX20115A-T4			
		< TRANSISTOR >			
Q1	8-729-620-05	TRANSISTOR 2SC2603-EF			
Q2	8-729-801-84	TRANSISTOR 2SB1013-4			
Q3	8-729-801-93	TRANSISTOR 2SD1387			
		< RESISTOR >			
R1	1-249-423-11	CARBON	3.3K	5%	1/4W
R2	1-249-429-11	CARBON	10K	5%	1/4W
R3	1-249-407-11	CARBON	150	5%	1/4W
R4	1-249-423-11	CARBON	3.3K	5%	1/4W
R5	1-249-421-11	CARBON	2.2K	5%	1/4W
R6	1-249-435-11	CARBON	33K	5%	1/4W
R7	1-247-807-31	CARBON	100	5%	1/4W
R8	1-249-417-11	CARBON	1K	5%	1/4W
R9	1-249-429-11	CARBON	10K	5%	1/4W
R11	1-249-429-11	CARBON	10K	5%	1/4W
R12	1-249-417-11	CARBON	1K	5%	1/4W
R14-17	1-249-441-11	CARBON	100K	5%	1/4W
R18	1-249-409-11	CARBON	220	5%	1/4W
R19	1-249-409-11	CARBON	220	5%	1/4W
R20	1-249-401-11	CARBON	47	5%	1/4W
R21	1-249-429-11	CARBON	10K	5%	1/4W

**DRUM DRIVE**   **HP**   **INPUT SW**   **LED**   **LOAD SW**   **LOADING MOTOR**   **MIC**

Ref. No.	Part No.	Description	Remark		
R22	1-249-433-11	CARBON	22K	5%	1/4W
R23	1-249-403-11	CARBON	68	5%	1/4W
R24	1-249-403-11	CARBON	68	5%	1/4W
R25	1-249-423-11	CARBON	3.3K	5%	1/4W
R26	1-249-423-11	CARBON	3.3K	5%	1/4W
*****					
R27	1-249-419-11	CARBON	1.5K	5%	1/4W
*****					
*	1-658-925-11	HP BOARD	*****		
< CAPACITOR >					
C222	1-102-114-00	CERAMIC	470PF	10%	50V
C374	1-126-024-11	ELECT	220uF	20%	25V
C375	1-126-024-11	ELECT	220uF	20%	25V
< RESISTOR >					
△FR301	1-212-857-00	FUSIBLE	10	5%	1/4W F
△FR302	1-212-857-00	FUSIBLE	10	5%	1/4W F
< IC >					
IC321	8-759-981-96	IC	RC4560D		
< JACK >					
J304	1-565-327-11	JACK, LARGE TYPE 1P (PHONES)			
< RESISTOR >					
R132	1-249-435-11	CARBON	33K	5%	1/4W
R133	1-249-431-11	CARBON	15K	5%	1/4W
R134	1-249-425-11	CARBON	4.7K	5%	1/4W
R135	1-247-807-31	CARBON	100	5%	1/4W
R232	1-249-435-11	CARBON	33K	5%	1/4W
R233	1-249-431-11	CARBON	15K	5%	1/4W
R234	1-249-425-11	CARBON	4.7K	5%	1/4W
R235	1-247-807-31	CARBON	100	5%	1/4W
< VARIABLE RESISTOR >					
RV302	1-241-537-11	RES, VAR, CARBON 20K/20K (PHONE LEVEL)			
*****					
*	1-658-922-11	INPUT SW BOARD	*****		
< RESISTOR >					
R726	1-249-425-11	CARBON	4.7K	5%	1/4W
R727	1-249-429-11	CARBON	10K	5%	1/4W
R728	1-249-435-11	CARBON	33K	5%	1/4W
R733	1-249-425-11	CARBON	4.7K	5%	1/4W
R734	1-249-423-11	CARBON	3.3K	5%	1/4W

Ref. No.	Part No.	Description	Remark		
< SWITCH >					
S720	1-762-538-11	SWITCH, ROTARY (INPUT)			
S725	1-762-537-11	SWITCH, ROTARY (REC MODE)			
*****					
*	1-658-926-11	LED BOARD	*****		
< CAPACITOR >					
C122	1-102-114-00	CERAMIC	470PF	10%	50V
< DIODE >					
D704-706	8-719-033-06	LED SEL5920A (ILLUMINATION)			
< RESISTOR >					
R750	1-249-403-11	CARBON	68	5%	1/4W
R751	1-249-409-11	CARBON	220	5%	1/4W
*****					
*	1-655-285-11	LOAD SW BOARD	*****		
< SWITCH >					
S902	1-571-489-11	SWITCH, SLIDE (UNLOAD)			
S903	1-571-489-11	SWITCH, SLIDE (LOAD)			
*****					
*	1-655-286-11	LOADING MOTOR BOARD	*****		
< CAPACITOR >					
C999	1-136-165-00	FILM	0.1uF	5%	50V
< CONNECTOR >					
* CN919	1-564-496-11	PIN, CONNECTOR 3P			
* CN920	1-564-497-11	PIN, CONNECTOR 4P			
*****					
*	1-658-924-11	MIC BOARD	*****		
< CAPACITOR >					
C141	1-162-294-31	CERAMIC	0.001uF	10%	50V
C142	1-162-294-31	CERAMIC	0.001uF	10%	50V
C143	1-128-440-11	ELECT	10uF	20%	50V
C144	1-162-286-31	CERAMIC	220PF	10%	50V
C145	1-124-995-11	ELECT	220uF	20%	10V
C241	1-162-294-31	CERAMIC	0.001uF	10%	50V

The components identified by mark **△** or dotted line with mark **△** are critical for safety. Replace only with part number specified.

<b>MIC</b>	<b>MOTOR</b>	<b>PRIMARY</b>	<b>REC EN</b>	<b>REC VOL</b>
------------	--------------	----------------	---------------	----------------

Ref. No.	Part No.	Description	Remark		
C242	1-162-294-31	CERAMIC	0.001uF	10%	50V
C243	1-128-440-11	ELECT	10uF	20%	50V
C244	1-162-286-31	CERAMIC	220PF	10%	50V
C245	1-124-995-11	ELECT	220uF	20%	10V
C380	1-164-159-11	CERAMIC	0.1uF		50V
C381	1-164-159-11	CERAMIC	0.1uF		50V
< IC >					
IC105	8-759-158-98	IC SSM-2017P			
IC205	8-759-158-98	IC SSM-2017P			
< JACK >					
* J101	1-764-618-11	JACK (LARGE TYPE) (MIC L)			
* J201	1-764-618-11	JACK (LARGE TYPE) (MIC R)			
< RESISTOR >					
R168	1-249-437-11	CARBON	47K	5%	1/4W
R169	1-247-807-31	CARBON	100	5%	1/4W
R170	1-249-425-11	CARBON	4.7K	5%	1/4W
R171	1-249-409-11	CARBON	220	5%	1/4W
R172	1-249-397-11	CARBON	22	5%	1/4W
R268	1-249-437-11	CARBON	47K	5%	1/4W
R269	1-247-807-31	CARBON	100	5%	1/4W
R270	1-249-425-11	CARBON	4.7K	5%	1/4W
R271	1-249-409-11	CARBON	220	5%	1/4W
R272	1-249-397-11	CARBON	22	5%	1/4W
< RELAY >					
RY303	1-755-061-11	RELAY			
*****					
* 1-655-913-11	MOTOR BOARD *****				
< CAPACITOR >					
C1	1-161-772-11	CERAMIC	0.1uF	10%	25V
< CONNECTOR >					
* CN1	1-564-498-11	PIN, CONNECTOR 5P			
* CN2	1-564-337-00	PIN, CONNECTOR 3P			
*****					
* 1-655-925-11	PRIMARY BOARD *****				
1-533-293-11	FUSE HOLDER				
1-550-414-21	HOLDER, BATTERY				

Ref. No.	Part No.	Description	Remark		
< CAPACITOR >					
△C901	1-113-916-11	CERAMIC	0.01uF		
△C902	1-113-916-11	CERAMIC	0.01uF		
△C903-906	1-113-920-11	ELECT	0.0022uF	20%	250V
< CONNECTOR >					
* CN901	1-580-230-31	PIN, CONNECTOR (PC BOARD) 2P			
CN902	1-770-353-21	PIN, CONNECTOR (PC BOARD) 2P			
CN903	1-770-354-11	PIN, CONNECTOR (PC BOARD) 2P			
< COIL >					
△L901	1-421-915-11	COIL, LINE FILTER			
< PLATE, GROUND >					
* LUG901	3-346-266-12	PLATE, GROUND			
*****					
* 1-654-393-11	REC EN BOARD *****				
< SWITCH >					
S901	1-572-459-11	SWITCH, PUSH (REC PROOF/CASSETTE IN)			
*****					
* 1-658-919-11	REC VOL BOARD *****				
< CAPACITOR >					
C146	1-126-059-11	ELECT	10uF	20%	50V
C246	1-126-059-11	ELECT	10uF	20%	50V
< CONNECTOR >					
* CN306	1-564-519-11	PLUG, CONNECTOR 4P			
CN313	1-691-767-11	PLUG (MICRO CONNECTOR) 5P			
< DIODE >					
D309	8-719-987-63	DIODE 1N4148M			
< RESISTOR >					
R101	1-249-434-11	CARBON	27K	5%	1/4W
R173	1-249-441-11	CARBON	100K	5%	1/4W
R201	1-249-434-11	CARBON	27K	5%	1/4W
R273	1-249-441-11	CARBON	100K	5%	1/4W
< VARIABLE RESISTOR >					
RV301	1-223-979-11	RES, VAR, CARBON 20K/20K (REC LEVEL)			

The components identified by mark  $\Delta$  or dotted line with mark  $\Delta$  are critical for safety. Replace only with part number specified.

**REC VOL**

**REMOTE CONTROL**

**RF AMP**

Ref. No.	Part No.	Description	Remark
		< RELAY >	
RY302	1-515-726-11	RELAY	
*****			
*	1-658-921-11	REMOTE CONTROL BOARD	
*****			
		< CAPACITOR >	
C705	1-164-159-11	CERAMIC 0.1uF	50V
		< CONNECTOR >	
* CN703	1-564-500-11	PIN, CONNECTOR 7P	
		< IC >	
IC703	8-741-810-59	IC ELEMENT, RAY-CATCHER SBX1810-59	
		< RESISTOR >	
R711	1-249-419-11	CARBON 1.5K 5% 1/4W	
R716	1-249-425-11	CARBON 4.7K 5% 1/4W	
R725	1-249-419-11	CARBON 1.5K 5% 1/4W	
R730	1-249-417-11	CARBON 1K 5% 1/4W	
R731	1-249-419-11	CARBON 1.5K 5% 1/4W	
R732	1-249-423-11	CARBON 3.3K 5% 1/4W	
		< SWITCH >	
S723	1-554-937-11	SWITCH, KEY BOARD (FADER)	
S724	1-554-937-11	SWITCH, KEY BOARD (MARGIN RESET)	
*****			
*	A-2006-455-A	RF AMP BOARD, COMPLETE	
*****			
		< CAPACITOR >	
C1	1-124-778-00	ELECT CHIP 22uF	20% 6.3V
C2	1-163-019-00	CERAMIC CHIP 0.0068uF	10% 50V
C3	1-163-251-11	CERAMIC CHIP 100PF	5% 50V
C4	1-107-682-11	CERAMIC CHIP 1uF	10% 16V
C5	1-164-299-11	CERAMIC CHIP 0.22uF	10% 25V
C6	1-164-004-11	CERAMIC CHIP 0.1uF	10% 25V
C7	1-163-009-11	CERAMIC CHIP 0.001uF	10% 50V
C8	1-124-778-00	ELECT CHIP 22uF	20% 6.3V
C9	1-124-778-00	ELECT CHIP 22uF	20% 6.3V
C10	1-163-009-11	CERAMIC CHIP 0.001uF	10% 50V
C11	1-164-004-11	CERAMIC CHIP 0.1uF	10% 25V
C12	1-164-299-11	CERAMIC CHIP 0.22uF	10% 25V
C13	1-107-682-11	CERAMIC CHIP 1uF	10% 16V
C14	1-163-251-11	CERAMIC CHIP 100PF	5% 50V
C15	1-124-778-00	ELECT CHIP 22uF	20% 6.3V

Ref. No.	Part No.	Description	Remark
C16	1-163-038-91	CERAMIC CHIP 0.1uF	25V
C17	1-163-001-11	CERAMIC CHIP 220PF	10% 50V
C18	1-163-251-11	CERAMIC CHIP 100PF	5% 50V
C19	1-163-001-11	CERAMIC CHIP 220PF	10% 50V
C20	1-164-182-11	CERAMIC CHIP 0.0033uF	10% 50V
C21	1-163-005-11	CERAMIC CHIP 470PF	10% 50V
C22	1-126-603-11	ELECT CHIP 4.7uF	20% 35V
C23	1-163-251-11	CERAMIC CHIP 100PF	5% 50V
C24	1-163-038-91	CERAMIC CHIP 0.1uF	25V
C25	1-124-778-00	ELECT CHIP 22uF	20% 6.3V
C26	1-163-038-91	CERAMIC CHIP 0.1uF	25V
C27	1-107-682-11	CERAMIC CHIP 1uF	10% 16V
C28	1-164-505-11	CERAMIC CHIP 2.2uF	16V
		< CONNECTOR >	
* CN51	1-566-207-11	PIN, CONNECTOR (PC BOARD) 14P	
* CN52	1-564-720-11	PIN, CONNECTOR (SMALL TYPE) 4P	
		< IC >	
IC1	8-752-039-01	IC CXA1364R	
		< COIL >	
L1	1-408-781-00	INDUCTOR CHIP 22uH	
L2	1-408-789-21	INDUCTOR CHIP 100uH	
L3	1-408-781-00	INDUCTOR CHIP 22uH	
		< RESISTOR >	
R1	1-216-082-00	METAL GLAZE 24K 5%	1/10W
R2	1-216-082-00	METAL GLAZE 24K 5%	1/10W
R3	1-216-066-00	METAL CHIP 5.1K 5%	1/10W
R4	1-216-066-00	METAL CHIP 5.1K 5%	1/10W
R5-7	1-216-077-00	METAL CHIP 15K 5%	1/10W
R8	1-216-079-00	METAL CHIP 18K 5%	1/10W
R9	1-216-075-00	METAL CHIP 12K 5%	1/10W
R10	1-216-079-00	METAL CHIP 18K 5%	1/10W
R11-13	1-216-077-00	METAL CHIP 15K 5%	1/10W
R14	1-216-081-00	METAL CHIP 22K 5%	1/10W
R15	1-216-085-00	METAL CHIP 33K 5%	1/10W
R16	1-216-089-91	METAL GLAZE 47K 5%	1/10W
R17	1-216-080-00	METAL CHIP 20K 5%	1/10W
R18	1-216-073-00	METAL CHIP 10K 5%	1/10W
		< VARIABLE RESISTOR >	
RV1	1-238-181-11	RES, ADJ, CERMET 4.7K (B REC PCM)	
RV2	1-238-181-11	RES, ADJ, CERMET 4.7K (A REC PCM)	
*****			

**S END****SBM SW****SW****T END****THICK**

Ref. No.	Part No.	Description	Remark	Ref. No.	Part No.	Description	Remark
*	1-654-392-11	S END BOARD ***** < TRANSISTOR >		△F501	1-532-286-00	FUSE (T2. 5A 250V)	
	Q950	1-808-957-11 TRANSISTOR PHOTO SENSOR *****		△F502	1-532-286-00	FUSE (T2. 5A 250V)	
*	1-658-923-11	SBM SW BOARD ***** < LEAD >		LUG301	1-537-770-21	TERMINAL BOARD, GROUND	
	LD702	1-690-880-51 LEAD (WITH CONNECTOR) < SWITCH >		LUG302	1-537-770-21	TERMINAL BOARD, GROUND	
	S704	1-572-269-11 SWITCH, SLIDE (SBM)		LUG304	1-537-770-21	TERMINAL BOARD, GROUND	
	S710	1-572-269-11 SWITCH, SLIDE (EMPHASIS) *****		LUG501	1-537-770-21	TERMINAL BOARD, GROUND	
*	1-655-916-11	SW BOARD ***** < SWITCH >		LUG503	1-537-770-21	TERMINAL BOARD, GROUND	
	S1	1-571-958-11 SWITCH, PUSH (1 KEY) (CASSETTE TABLE IN)		* LUG901	3-346-266-12	PLATE, GROUND	
	S2	1-571-958-11 SWITCH, PUSH (1 KEY) (CASSETTE TABLE OUT) *****		M901	A-2004-301-A	MOTOR ASSY, CONTROL (LOADING)	
*	1-654-391-11	T END BOARD ***** < TRANSISTOR >		M902	8-835-306-01	MOTOR, DC U-17A (CAPSTAN)	
	Q951	1-808-957-11 TRANSISTOR PHOTO SENSOR *****		* M903	8-835-205-01	MOTOR, DC U-2A (REEL) (including PM901)	
	1-654-394-12	THICK BOARD ***** < SWITCH >		M904	8-848-626-11	DRUM ASSY DOU-03D	
	S904	1-572-458-11 SWITCH, PUSH (THICK) *****		M905	X-3370-655-1	MOTOR ASSY (CASSETTE COMPARTMENT)	
		MISCELLANEOUS *****		PM902	1-454-522-11	SOLENOID, PLUNGER	
	6	1-776-000-11 WIRE (FLAT TYPE) (31 CORE)		△T901	1-427-913-11	TRANSFORMER, POWER	
	14	1-776-001-11 WIRE (FLAT TYPE) (21 CORE)		*****			
△	24	1-558-568-21 CORD, POWER		ACCESSORIES & PACKING MATERIALS *****			
	26	1-543-762-11 BEAD, FERRITE		1-473-087-11	REMOTE COMMANDER (RM-D868)		
	57	1-572-267-51 SWITCH, PUSH (AC POWER) (1 KEY)		1-558-271-11	CORD, CONNECTION		
	61	1-769-541-11 WIRE (FLAT TYPE) (17 CORE)		* 3-384-415-01	CUSHION (AEP)		
	80	1-776-002-11 CORD (WITH CONNECTOR)		* 3-384-415-01	CUSHION (G)		
				3-800-368-11	MANUAL, INSTRUCTION (ENGLISH, FRENCH, SPANISH, PORTUGUESE) (AEP)		
				3-800-368-31	MANUAL, INSTRUCTION (GERMAN) (G)		
				3-800-368-41	MANUAL, INSTRUCTION (GERMAN, DUTCH, SWEDISH, ITALIAN) (AEP)		
				* 3-929-706-01	INDIVIDUAL CARTON (AEP)		
				* 3-929-706-01	INDIVIDUAL CARTON (G)		
				4-962-615-01	COVER, BATTERY (FOR REMOTE COMMANDER)		
				*****			
				*****			
				<b>HARDWARE LIST</b> *****			
				#1	7-682-548-09	SCREW +BVT 3×8 (S)	
				#2	7-682-548-04	SCREW +BVT 3×8 (S)	
				#3	7-685-646-79	SCREW +BVTP 3×8 TYPE2 SLIT	
				#4	7-621-772-08	SCREW +B 2×3	
				#5	7-685-132-19	SCREW +BTP 2.6×5 TYPE2 N-S	
				#6	7-685-534-19	SCREW +BTP 2.6×8 TYPE2 N-S	
				#7	7-621-772-18	SCREW +B 2×4	
				#8	7-682-550-09	SCREW +B 3×12	
				#9	7-621-772-20	SCREW +B 2×5	
				#10	7-621-773-86	SCREW +B 2.6×4	
				#11	7-685-871-01	SCREW +BVT 3×6 (S)	
				#12	7-627-556-17	SCREW, PRECISION +P 2.6×3 TYPE1	
				#13	7-621-775-08	SCREW +B 2.6×3	

The components identified by mark **△** or dotted line with mark **△** are critical for safety. Replace only with part number specified.

<u>Ref.No.</u>	<u>Part No.</u>	<u>Description</u>	<u>Remark</u>
#14	7-627-553-67	SCREW, PRECISION +P 2×5	
#15	7-627-553-27	SCREW, PRECISION +P 2×2.5	
#16	7-621-772-30	SCREW +B 2×6	
#17	7-627-852-48	PRECISION SCREW +P 1.7×3.5 TYPE3	
#18	7-627-552-47	SCREW, PRECISION +P 1.7×4	
#19	7-685-102-19	SCREW +P 2×4 TYPE2 NON-SLIT	
#20	7-627-553-38	SCREW, PRECISION +P 2×3	
#21	7-685-133-19	SCREW +BTP 2.6×6 TYPE2 N-S	
#22	7-628-253-00	SCREW +PS 2×4	
#23	7-682-565-09	SCREW +BVTT 4×16	
#24	7-685-645-79	SCREW +BTP 3×6 TYPE2 IT-3	