

ICD-BM1VTP

SERVICE MANUAL

US Model

Ver. 1.0 2005. 05



SPECIFICATIONS

Recording media "Memory Stick", Monaural recording
Recording time
Maximum recording time and number of messages for a "Memory Stick"
The maximum recording time for all the folders and the maximum number of messages are as follows. You can record messages for the maximum recording time in a single folder.

	4MB	8MB	16MB	32MB	64MB	128MB
ST*	10min.	20min.	40min.	1hr 25min.	2hr 50min.	5hr 50min.
SP**	30min.	1hr	2hr 10min.	4hr 20min.	8hr 50min.	17hr 45min.
LP***	1hr 20min.	2hr 50min.	5hr 45min.	11hr 45min.	23hr 35min.	47hr 25min.
Number of Messages	456	950	963	1,016	1,016	1,016

*ST: High quality recording mode (hr: hours /min.: minutes)
(stereo sound with an external stereo microphone not supplied)

**SP: Standard play recording mode (monaural sound)

***LP: Long play recording mode (monaural sound)

Frequency range	ST: 60 Hz - 13,500 Hz SP: 60 Hz - 7,000 Hz LP: 80 Hz - 3,500 Hz
Speaker	approx. 28 mm (29/32 in.) dia.
Power output	350 mW
Input/Output	• Earphone jack (minijack) for 8 - 300 ohms ear receiver/headphones • Microphone jack (minijack, stereo) Plug in power Minimum input level: 0.7 mV 3 kilohms or lower impedance microphone • USB connector • DC IN 3V jack
Playback speed control	+100% to -50% (DPC)
Power requirements	Two size AAA (LR03) alkaline batteries: 3 V DC
Dimensions	36.6 × 112.3 × 21mm (1 1/2 × 4 1/2 × 27/32 in.) (w/h/d) (not incl. projecting parts and controls)
Mass	98 g (3.5 oz) (incl. batteries and a "Memory Stick")
Supplied accessories	"Memory Stick" (16MB × 1) "Digital Voice Editor" (CD-ROM) × 1 "Dragon Naturally Speaking Preferred" (CD-ROM) × 1 Ear receiver × 1 USB connecting cable × 1 Carrying case × 1 Clamp filter × 1

Design and specifications are subject to change without notice.

IC RECORDER

9-879-704-01
2005E04-1
© 2005. 05

Sony Corporation
Connect Company
Published by Sony Engineering Corporation

SONY®

Flexible Circuit Board Repairing

- Keep the temperature of the soldering iron around 270°C during repairing.
- Do not touch the soldering iron on the same conductor of the circuit board (within 3 times).
- Be careful not to apply force on the conductor when soldering or unsoldering.

Notes on Chip Component Replacement

- Never reuse a disconnected chip component.
- Notice that the minus side of a tantalum capacitor may be damaged by heat.

* Replacement of IC601, IC702 used in this set requires a special tool.

- The voltage and waveform of CSP (chip size package) cannot be measured, because its lead layout is different from that of conventional IC.

- Lead layouts

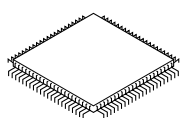

Lead layout of conventional IC

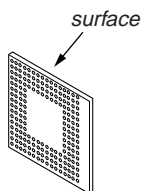

CSP (chip size package)

● UNLEADED SOLDER

Boards requiring use of unleaded solder are printed with the lead-free mark (LF) indicating the solder contains no lead. (Caution: Some printed circuit boards may not come printed with the lead free mark due to their particular size.)



LF : LEAD FREE MARK

Unleaded solder has the following characteristics.

- Unleaded solder melts at a temperature about 40°C higher than ordinary solder.
Ordinary soldering irons can be used but the iron tip has to be applied to the solder joint for a slightly longer time. Soldering irons using a temperature regulator should be set to about 350°C.
Caution: The printed pattern (copper foil) may peel away if the heated tip is applied for too long, so be careful!
- Strong viscosity
Unleaded solder is more viscous (sticky, less prone to flow) than ordinary solder so use caution not to let solder bridges occur such as on IC pins, etc.
- Usable with ordinary solder
It is best to use only unleaded solder but unleaded solder may also be added to ordinary solder.

SAFETY-RELATED COMPONENT WARNING!!

COMPONENTS IDENTIFIED BY MARK \triangle OR DOTTED LINE WITH MARK \triangle ON THE SCHEMATIC DIAGRAMS AND IN THE PARTS LIST ARE CRITICAL TO SAFE OPERATION. REPLACE THESE COMPONENTS WITH SONY PARTS WHOSE PART NUMBERS APPEAR AS SHOWN IN THIS MANUAL OR IN SUPPLEMENTS PUBLISHED BY SONY.

TABLE OF CONTENTS

1. GENERAL

Index to Parts and Controls	3
Getting Started	3
Basic Operations	5
Editing Messages	8
Formatting a "Memory Stick"	9

2. DISASSEMBLY

2-1. Knob (Rear)	10
2-2. Chassis Block Assy	11
2-3. SW Board	11
2-4. Plate (MS) Section	12
2-5. LCD Board	12
2-6. Chassis Section	13
2-7. Memory Stick Connector	13
2-8. Main Board	14

3. DIAGRAMS

3-1. IC Pin Descriptions	15
3-2. Block Diagram – Main Section –	21
3-3. Block Diagram – LCD/SW Section –	22
3-4. Printed Wiring Board – Main Section –	24
3-5. Schematic Diagram – Main Section (1/3) –	25
3-6. Schematic Diagram – Main Section (2/3) –	26
3-7. Schematic Diagram – Main Section (3/3) –	27
3-8. Schematic Diagram – LCD/SW Section –	28
3-9. Printed Wiring Board – LCD Section –	29
3-10. Printed Wiring Board – SW Section –	30

4. EXPLODED VIEWS

4-1. Main Section	34
4-2. Case Section	35
4-3. Ornament Section	36
4-4. Chassis (1) Section	37
4-5. Chassis (2) Section	38

5. ELECTRICAL PARTS LIST

SECTION 1 GENERAL

This section is extracted from instruction manual.

Index to Parts and Controls

Refer to the pages indicated in parentheses for details.

Front

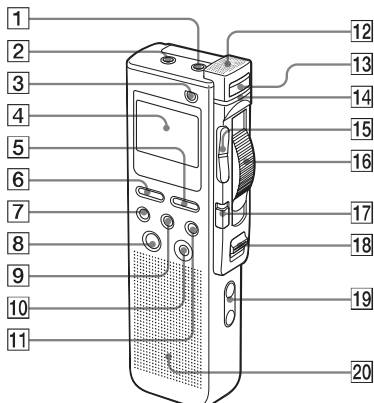

- | | |
|--|--|
| 1 MIC (microphone) (PLUG IN POWER) jack (18) | 12 Built-in microphone (14) |
| 2 (headphones) jack (16, 19, 21) | 13 NEW FILE button (15) |
| 3 ERASE button (29, 34) | 14 OPR (operation) indicator (14, 21) |
| 4 Display window (24) | 15 Jog lever ◀◀ (review/fast backward)/▶▶ (cue/fast forward) |
| 5 MENU button (49) | 16 Control key REC (record) / STOP/PLAY/B.SPAC |
| 6 DISPLAY button (26) | 17 DPC switch (22, 39) |
| 7 FOLDER button (13, 20) | 18 POWER ON/OFF switch (8, 13) |
| 8 ENTER button | 19 VOL (volume) +/- buttons (21) |
| 9 DIVIDE button | 20 Speaker |
| 10 CANCEL button | |
| 11 PRIORITY button (36) | |

64^{GB}

Rear

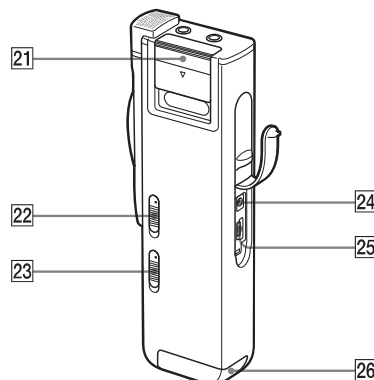

- | |
|--|
| 21 Memory Stick slot cover (10) |
| 22 MIC SENS (microphone sensitivity) switch (17) CONF(H) (conference, high)/DICT(L) (dictation, low) |
| 23 VOR (voice operated recording) ON/OFF switch (16) |
| 24 DC IN 3V jack (6) |
| 25 USB connector (52) |
| 26 Battery compartment (6) |

65^{GB}

Additional Information

Using the Display Window

Parts in the display window

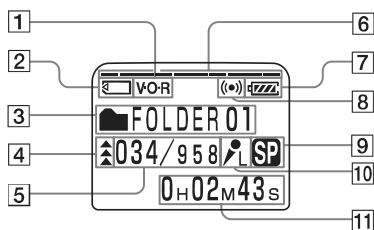

- | | |
|--|--|
| 1 VOR (voice operated recording) indicator (16) | 10 Microphone sensitivity indication (17)
Displays the current microphone sensitivity setting with the MIC SENS (microphone sensitivity) switch:
• H (high): CONF(H) position is selected to record at a meeting or in a quiet/spacious place.
• L (low): DICT(L) position is selected to record for dictation. |
| 2 "Memory Stick" indicator | 11 Counter /Remaining time indication /Recording date and time indication / Message name indication/ Current time indication (26, 27)
The display selected with the DISPLAY button appears. |
| 3 Folder indication (13, 20)
Displays the current folder. | |
| 4 Priority marks (36) | |
| 5 Selected message number / Total message number in the folder (14, 20) | |
| 6 Remaining memory indicator (17) | |
| 7 Remaining battery indicator (7)
When the AC power adaptor (not supplied) is connected, the indicator does not appear. | |
| 8 Alarm indicator (45)
Appears when the alarm is set for a message. | |
| 9 Recording mode indication (50)
• ST: High quality recording mode (stereo sound with an external stereo microphone not supplied)
• SP: Standard play recording mode (monaural sound)
• LP: Long play recording mode (monaural sound) | |
- Note**
The effect of the back light of the display window may be reduced in a bright location.

24^{GB}

▶ Getting Started

Step 1: Installing the Batteries

- Slide and lift the battery compartment lid.

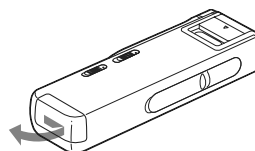

- Insert two LR03 (size AAA) alkaline batteries with correct polarity, and close the lid.

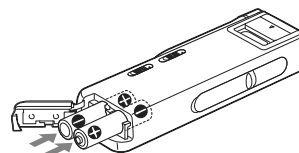

Clock setting display appears when you insert batteries for the first time or after the unit has been without batteries for a certain period of time. Please refer to steps 3 to 6 in "Step 2: Setting the Clock" on pages 8 and 9 to set the date and time.

Using on house current

Connect the AC power adaptor AC-E30HG (not supplied) to the DC IN 3V jack of the unit and to the wall outlet. Do not use any other AC power adaptor.



Polarity of the plug

6^{GB}

Replacing the Batteries

The battery indicator on the display window shows the battery condition.

Notes

- Do not use manganese batteries for this unit.
- When you replace the batteries, insert the new ones within 3 minutes after you remove the exhausted ones. Otherwise, the display may show the clock setting or incorrect date and time when you re-insert the batteries. In this case, set the date and time again. The recorded messages and alarm setting, however, will remain.
- Do not charge dry batteries.
- When you are not going to use the unit for a long time, remove the batteries to prevent damage from battery leakage and corrosion.

Battery remain indication

: Replace both of the two batteries with new ones.

: The "LOW BATTERY" is displayed and the unit will stop operation.

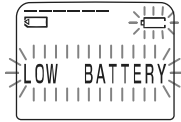

Battery life (Using Sony alkaline batteries LR03 (SG))

(Recording mode:)	ST	SP	LP
In continuous recording:	Approx. 11 hours	Approx. 14 hours	Approx. 16 hours
In continuous playback*:	Approx. 6.5 hours	Approx. 7.5 hours	Approx. 8.5 hours

* When playing back through the internal speaker with the medium volume level

* The battery life may shorten depending on the operation of the unit.

7^{GB}

4 Press ENTER.

The date and time setting window is displayed. The year digits will flash.

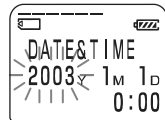

5 Set the date and time.

- Press the jog lever up or down (▶▶/◀◀) to select the digits of the year.
- Press ENTER.
- The month digit will flash. Set the month, day, and the time in sequence, then press ENTER. The menu mode will be displayed again.

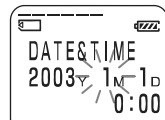

6 Press MENU.

The window will return to the normal display.

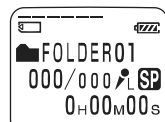

To cancel the operation

Press CANCEL to return to the previous step of the operations.

To display the current time

Press ENTER while the unit is in the stop mode (page 27). The current time will be displayed for three seconds.

Note

When no "Memory Stick" is inserted or the power is turned off, the current time will not be displayed.



9^{GB}

Step 2: Setting the Clock

You need to set the clock to use the alarm function or record the date and time.

Clock setting display appears when you insert battery for the first time, or when you insert battery after the unit has been without battery for a certain period of time. In this case, proceed from step 4.

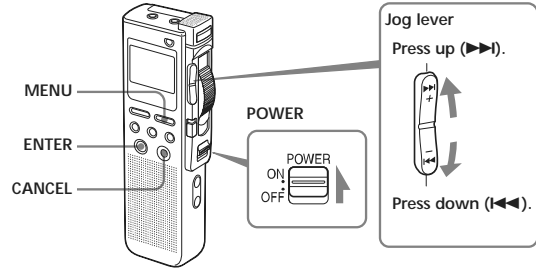

1 Slide POWER to ON.

The IC recorder is turned on.



2 Press MENU.

The menu mode will be displayed in the display window.

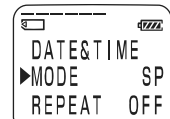

3 Press the jog lever up or down (▶▶/◀◀) to select "DATE&TIME".

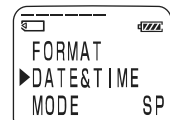

8^{GB}

Step 3: Inserting a "Memory Stick" into the IC Recorder

Notes

- Make sure to insert or remove the "Memory Stick" while the unit is turned off.
- Never remove the "Memory Stick" while the unit is accessing the "Memory Stick". (The OPR indicator flashes in orange.)

1 Slide and open the "Memory Stick" slot cover.

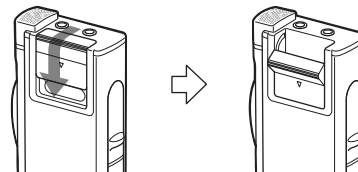

2 Insert a "Memory Stick" into the "Memory Stick" slot with the terminal side facing inside the recorder. Insert it firmly until it clicks into place.

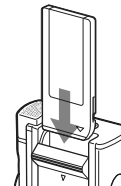

Note

Do not insert a "Memory Stick" in a different direction. It may cause malfunction of the unit.

3 Close the "Memory Stick" slot cover.

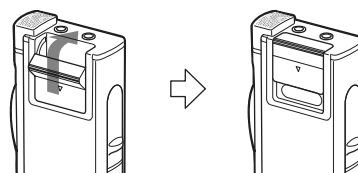

10^{GB}

Getting Started

Getting Started

Note on the "ACCESS" message

The unit is accessing data while "MEMORY STICK ACCESS" appears in the display window or the OPR indicator flashes in orange. While accessing, do not remove the "Memory Stick", batteries, or the AC adaptor (not supplied). Doing so may damage the data.

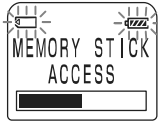

Notes

- The unit starts accessing the data after it is turned on.
- If the unit is required to process excessive amount of data, "MEMORY STICK ACCESS" may be displayed for an extended period of time. This is not a malfunction of the unit. Wait until the message disappears.

Removing the "Memory Stick"

Make sure that "MEMORY STICK ACCESS" disappears, and turn off the unit. Then open the "Memory Stick" slot cover and push the "Memory Stick" into the slot, so that the "Memory Stick" pops out. Remove the "Memory Stick" from the slot as shown below.

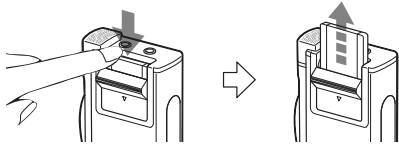

The types of "Memory Stick" you can use with this IC Recorder

You can also use the following "Memory Stick" of a 4 MB to 128MB capacity instead of the supplied "Memory Stick". The maximum recording time varies depending on the capacity of the "Memory Stick".

- "Memory Stick"
- "Memory Stick (with memory selectfunction)" (incorporating two 128MB memory units)
- "MagicGate Memory Stick"
- "Memory Stick Duo" (when inserted into the "Memory Stick Duo" adaptor)

Notes

- The unit does not support the "Memory Stick PRO".
- "MagicGate" is a copyright protection technology that uses an encryption technology. This unit does not support the MagicGate standard, and therefore, recorded data using this unit is not subject to the protection of copyrights by MagicGate.

11GB

Getting Started

Basic Operations

Recording Messages

You can record messages in each (initially named FOLDER01, FOLDER02, and FOLDER03) folder. The maximum number of recordable messages differs depending on the "Memory Stick" capacity.

You can record messages using the following three functions:

- Add a recording to a previously recorded message (next page)
- Add a recording as a new message (page 15)
- Add an overwrite recording (page 15)

This section explains how to add a recording to a previously recorded message.

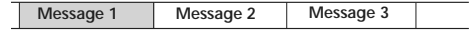

Starts recording at the end of Message 1



Added recording (counted as a part of Message 1)

Maximum recording time and number of messages for a "Memory Stick"

The maximum recording time for all the folders and the maximum number of messages are as follows. You can record messages for the maximum recording time in a single folder.

	4MB	8MB	16MB	32MB	64MB	128MB
ST*	10min.	20min.	40min.	1hr 25min.	2hr 50min.	5hr 50min.
SP**	30min.	1hr	2hr 10min.	4hr 20min.	8hr 50min.	17hr 45min.
LP***	1hr 20min.	2hr 50min.	5hr 45min.	11hr 45min.	23hr 35min.	47hr 25min.
Number of Messages	456	950	963	1,016	1,016	1,016

*ST: High quality recording mode (stereo sound with an external stereo microphone not supplied) (hr: hours / min.: minutes)

**SP: Standard play recording mode (monaural sound)

***LP: Long play recording mode (monaural sound)

Notes

- For switching the recording mode, see page 50.
- Before making a long recording, be sure to check the battery indicator (page 7).
- The maximum recording time and the number of messages you can make vary depending on the conditions of use.
- To avoid replacing batteries during long recordings, use the AC power adaptor (not supplied).

12GB

1 Turn on the power.

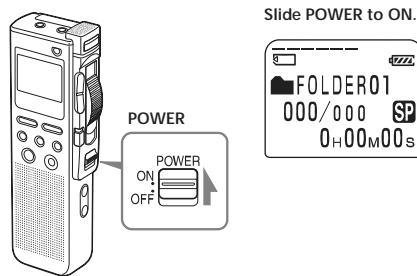

Slide POWER to ON.

2 Select the folder.

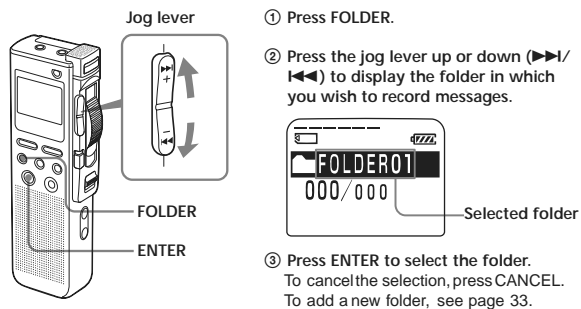

① Press FOLDER.

② Press the jog lever up or down (▶/◀) to display the folder in which you wish to record messages.

③ Press ENTER to select the folder. To cancel the selection, press CANCEL. To add a new folder, see page 33.

Basic Operations

Continued
13GB

Recording Messages (continued)

3 Start recording.

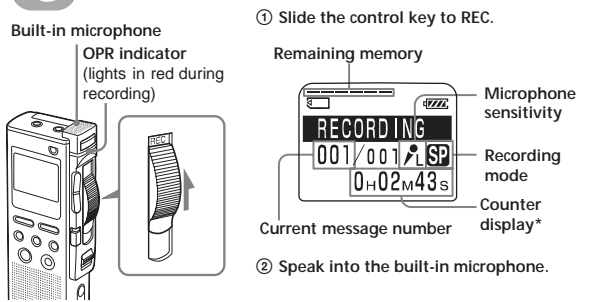

① Slide the control key to REC.

② Speak into the built-in microphone.

* The display selected with the DISPLAY button (page 26) appears.

Notes

- While the OPR indicator flashes or when it turns orange, do not remove the "Memory Stick", the batteries or the AC adaptor (not supplied). Doing so may damage the data.
- Noise may be recorded if an object, such as your finger, etc., accidentally rubs or scratches the unit during recording.

4 Stop recording.

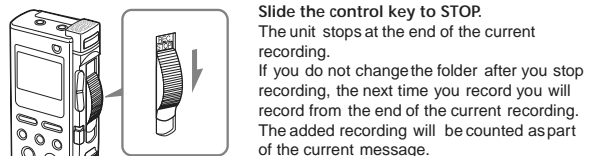

Slide the control key to STOP.

The unit stops at the end of the current recording.

If you do not change the folder after you stop recording, the next time you record you will record from the end of the current recording. The added recording will be counted as part of the current message.

14GB

Recording as a New Message

You can add a recording as a new message after the last message in the folder.

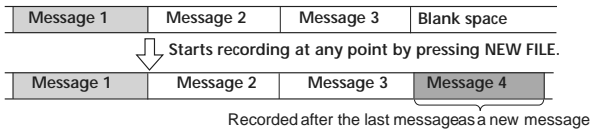

Before you start recording in step 3 on the previous page, press NEW FILE. "NEW FILE" will be displayed. Then slide the control key to REC to start a new recording as the last message in the folder.

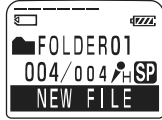

Basic Operations

Adding an Overwrite Recording

When you start recording at a point in the middle of a recorded message, you add an overwrite recording after the selected point.

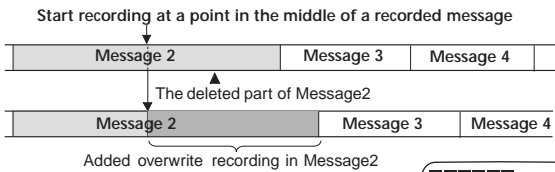

Locate the point where you want to start recording (page 21) and then slide the control key to REC. "ADD REC" will be displayed and you can add an overwrite recording to the current message.

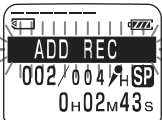

- Tips**
- You can select the overwrite recording mode using the menu (page 41).
 - The overwrite recording will be added in the same recording mode as the original message, regardless of the current recording mode setting.

Note
Playback after the overwrite recording starts from the beginning of the message. Playback after a stop starts from the point where you stopped playback.

Continued
15^{GB}

Selecting the microphone sensitivity

Slide the MIC SENS (microphone sensitivity) switch during stop or recording mode according to the recording conditions:

- CONF(H) (high): To record a small sound at a conference or in a quiet and/or spacious place.
- DICT(L) (low): To record for dictation.

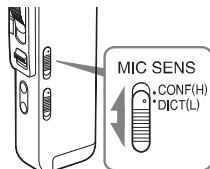

Using the memory remain indication

During recording, the remaining memory indicator decreases one by one. When the remaining recording time reaches 5 minutes, the remaining memory indication flashes.

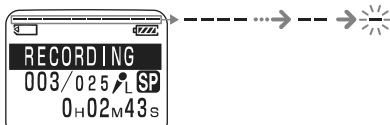

When the remaining time reaches 1 minute, the remaining time indication will flash in the display window regardless of the display mode (page 26).

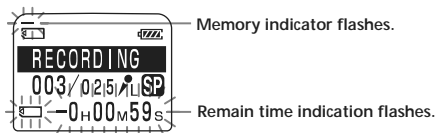

Memory indicator flashes.

Remain time indication flashes.

When the memory is full, recording automatically stops and "NO MEMORY SPACE" will be displayed with an alarm sound. Please slide the control key to STOP. To continue recording, erase some of the messages (page 28) or replace the "Memory Stick".

Note
When you set the BEEP (page 51) to OFF, an alarm sound (beep) does not sound.

17^{GB}

Recording Messages (continued)

Using Convenient Functions while Recording

Reviewing the recording

Slide the control key to B.SPACE. You can search backwards while listening to fast playback sound. After you slide the control key to PLAY, playback starts from that point. You can add an overwrite recording from that point.

Monitoring the recording

When recording, you can connect an ear receiver supplied or not supplied to the ϕ (headphones) jack and monitor the recording from the connected ear receiver. You can adjust the volume with VOL +/-, but the recording level is fixed.

Note

If you turn up the volume excessively or place the ear receiver near the microphone while monitoring recording, the microphone may pick up the sound from the ear receiver, causing acoustic feedback (howling sound).

Starting recording automatically in response to the sound — Advanced VOR function

Slide the VOR (voice operated recording) switch to ON during stop or recording mode. Set the control key to REC. Recording starts when the unit detects sound, and "VOR" appears in the display window. The recording pauses when no sound is detected, and "VOR PAUSE" appears.

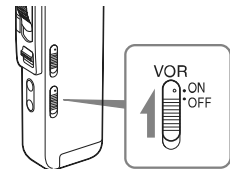

Notes

- Recording will not be started unless the control key is set to REC.
- VOR function is affected by the sound around you. Set the MIC SENS (microphone sensitivity) switch according to the recording conditions. If recording is not satisfactory after you have changed the microphone sensitivity, or for important recording, set the VOR switch to OFF.

16^{GB}

Recording with an External Microphone or Other Equipment

You can record sound of an external microphone or other equipment (tape recorder, MiniDisc player, or etc.) with the IC recorder. Depending on the device you use, connect the IC recorder as follows. For available accessories consult with your nearest Sony dealer.

Recording with an External Stereo Microphone

Connect an external stereo microphone to the MIC (microphone) jack. You can enjoy the stereo recording by using a stereo microphone.

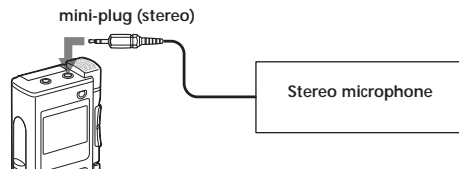

When you connect an external microphone, the built-in microphone is automatically cut off. When a plug in power type microphone is connected, power is automatically supplied to the microphone from the IC recorder.

Recommended types of microphones

You can use the ECM-DS70P Sony electret condenser microphone (not supplied).

Note

Before you start the stereo recording with an external stereo microphone, set MODE to ST in the menu (page 50).

18^{GB}

Recording from Other Equipment

To record sound of other equipment with the IC recorder, connect the MIC (microphone) jack of the IC recorder to the earphone jack of other equipment (tape recorder etc.) by using an audio connecting cable.

Notes

- When the audio recording level is large, sound may be recorded interrupted if you use an audio connecting cable without register. Use a registered audio connecting cable.
- When the audio recording level is small, do not use a registered audio connecting cable.

Recording with Other Equipment

To record the sound of the IC recorder with other equipment, connect the ϕ (headphones) jack of the IC recorder to the audio input connector (minijack, stereo) of other equipment.

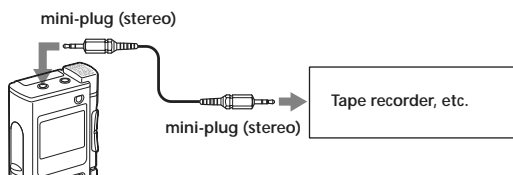

Basic Operations

Playing Back Messages

When playing back a previously recorded message, start from Step 1. When playing back a message you have just finished recording, start from Step 3.

1 Select the folder.

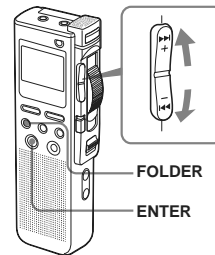

- ① Press FOLDER.
- ② Press the jog lever up or down ($\blacktriangleright/\blacktriangleleft$) to display the folder containing the message you want to play back.



- ③ Press ENTER to select the folder. To cancel the selection, press CANCEL.

2 Select the message number.



Press the jog lever up or down ($\blacktriangleright/\blacktriangleleft$) to display the desired message number.
 Press up (\blacktriangleright): for next message number.
 Press down (\blacktriangleleft): for previous message number.

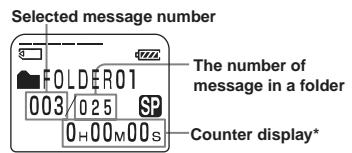

* The display selected with the DISPLAY button (page 26) appears.

19GB

20GB

3 Start playback.

OPR indicator (lights in green during playback)

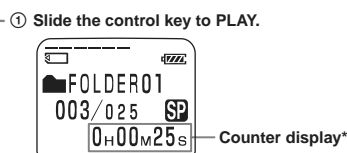

- ① Slide the control key to PLAY.
 - ② Adjust the volume with VOL +/- .
- * The display selected with the DISPLAY button (page 26) appears.
- The unit plays back all the messages in a folder continuously. At the end of each message, a beep will sound.

When the unit reaches to the end of the last message in a folder, "MSG END" will flash 3 times with a beep and playback stops. Move the control key to STOP.

To listen from an ear receiver

Connect the supplied ear receiver to the ϕ (headphones) jack. The built-in speaker will be automatically disconnected.

To listen from an external speaker

Connect an active or passive speaker (not supplied) to the ϕ (headphones) jack.

Note

Playback after the overwrite recording starts from the beginning of the message. Playback after a stop starts from the point where you stopped playback.

Basic Operations

4 Stop playback.

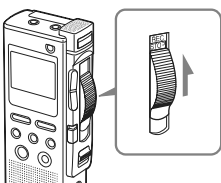

Slide the control key to STOP.
 The unit stops at the current position. (When the unit reaches to the end of the last message in step 3, it stops at the end of the last message.)
 You can start an overwrite recording from the point (page 15).

Continued

21GB

Playing Back Messages (continued)

Other operations

To	Do this
go back to the beginning of the current message*	Press the jog lever down (\blacktriangleleft) once.**
go back to previous messages*	Press the jog lever down (\blacktriangleleft) repeatedly. (During stop mode, keep the button pressed to go back the messages continuously.)**
skip to the next message*	Press the jog lever up (\blacktriangleright) once.***
skip to the succeeding messages*	Press the jog lever up (\blacktriangleright) repeatedly.***

* These operations are for when EASY-S is set to OFF. For operations when EASY-S is set to ON, see page 51.

** If you do these operations at the beginning of the first message in a folder during stop mode, the unit locates the end of the last message.

*** If you do these operations at the end of the last message in a folder during stop mode, the unit locates the beginning of the first message.

Playing back a message rapidly or slowly in natural tone — DPC (Digital Pitch Control)

When you adjust the playback speed with the DPC in the menu (pages 39 and 40), you can play back a message rapidly or slowing by sliding the DPC switch to ON. When you set the playback speed faster or slower of the normal speed, "FAST PLAY" or "SLOW PLAY" appears. You can change the setting during playback.

Searching forward/backward during playback (Cue/Review)

- To search forward: Keep pressing the jog lever up (\blacktriangleright) during playback and release it at the point you wish to resume playback.
- To search backward: Slide the control key to B.SPACE or keep pressing the jog lever down (\blacktriangleleft) during playback and release it at the point you wish to resume playback.

The unit searches at slow speed (unit of 4 seconds) with playback sound. It is useful to check one word forward or behind. Then, if you keep pressing the jog lever up or down, the unit starts to search at higher speed. Release it at the point you want to resume playback.

22GB

When you play back to the end of the last message

When the unit locates the end of the last message, "MSG. END" flashes 3 times with a beep and the OPR indicator lights in green.

- When "MOVE CONTROL KEY TO STOP POSITION" appears, slide the control key to STOP. The unit will stop at the end of the last message.
- To go back to the beginning of the first message in a folder during stop mode, press the jog lever up (▶▶).
- If you slide the control key to B.SPACE or keep pressing the jog lever down (◀◀), the messages are played back rapidly, and normal playback will start at the point you release the button.
- If the last message is long and you wish to start playback at a later part of the message, keep pressing the jog lever up (▶▶) to go to the end of the message and then press the jog lever down (◀◀) to go back to the desired point.

Quickly locating the point at which you wish to start playback (Easy Search)

When EASY-S is set to ON (page 51) in the menu, you can quickly locate the point you wish to start playback by pressing the jog lever up or down (▶▶/◀◀) repeatedly during playback.

You can go back approximately 3 seconds by pressing the jog lever down (◀◀) once, or advance approximately 10 seconds by pressing the jog lever up (▶▶) once. This function is useful when locating a desired point in a long recording.

Basic Operations

Playing back a message repeatedly — Repeat Play

When REPEAT is set to ON in the menu (page 50), you can play back a message repeatedly. Slide the control key to PLAY. "MSG.REPEAT" will be displayed and the selected message will be played back repeatedly. To stop playback, slide the control key to STOP. To resume normal playback, set REPEAT to OFF in the menu.



23^{GB}

1 Press ERASE while playing back the message you want to erase or press ERASE for more than 1 second during stop mode. "ERASE?" will flash while the first and last 5 seconds of the message are played back 10 times.

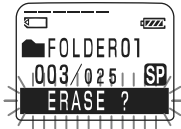

2 Press ENTER while the message is being played back and "ERASE" is flashing. The message is erased and the remaining messages will be renumbered. (For example, if you erase Message 3, Message 4 will be renumbered as Message 3. When erasing is completed, the unit will stop at the current position.)

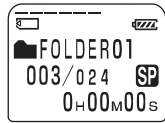

Editing Messages

To cancel erasing

Press CANCEL before step 2.

To erase other messages

Repeat steps 1 and 2.

To erase a message partially

First divide the message (see page 31) and then follow the steps on this page to erase the message.

Continued

29^{GB}

Editing Messages

Erasing Messages

You can erase the recorded messages one by one or all messages in a folder at a time.

Note

Once a recording has been erased, you cannot retrieve it.

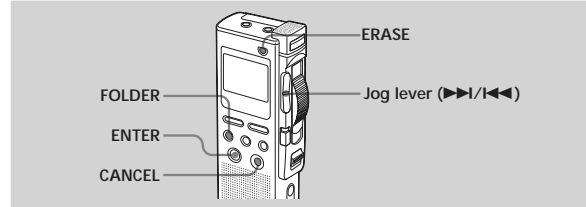

Erasing Messages one by one

Be sure to erase unnecessary messages only.

When a message is erased, the remaining messages will advance and be renumbered so that there will be no space between messages.

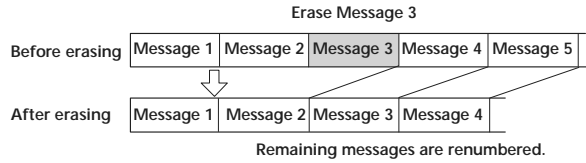

28^{GB}

Erasing Messages (Continued)

Erasing All Messages in a Folder

You can erase all recorded messages in a folder.

1 Select the folder containing the messages you want to erase. For information on selecting a folder, see step 2 of "Recording Messages" on page 13.

2 While pressing FOLDER, press ERASE for more than 1 second. "ERASE ALL?" will flash for 10 seconds.

If no messages are recorded in a folder "ERASE FOLDER?" will flash and you can erase the folder itself (see page 34).



3 While "ERASE ALL?" is flashing, press ENTER. All the recorded messages contained in the folder are erased. The folder itself will not be deleted. For how to erase a folder, see page 34.



To cancel erasing

Press CANCEL before step 3.

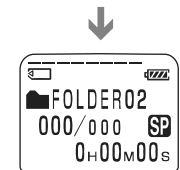

Formatting a "Memory Stick"

You can format a "Memory Stick" using the Memory Stick IC Recorder. Formatting will delete all data recorded in the "Memory Stick" including images and other data. Before formatting, check the data in the "Memory Stick".

Because a commercially available "Memory Stick" has already been formatted at the factory, you do not need to format a "Memory Stick" before the first use.

The supplied "Memory Stick" has also already been formatted.

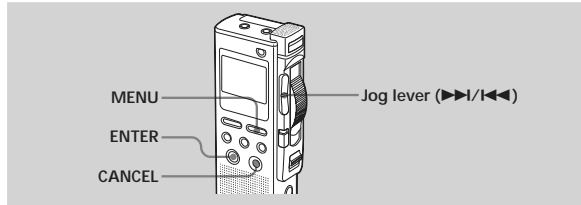

- 1** Press MENU.
The menu mode will be displayed.
- 2** Press the jog lever up or down (▶▶/◀◀) to select "FORMAT".
- 3** Press ENTER.
The formatting window will be displayed.
- 4** Press the jog lever up or down (▶▶/◀◀) to select "YES".

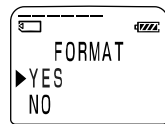

Other Functions

Continued

47^{GB}

Formatting a "Memory Stick" (continued)

- 5** Press ENTER.
"OK?" will be displayed in the display window.

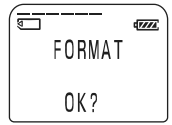

- 6** Press ENTER again.
Formatting starts.
"FORMATTING" will be displayed on the display.
After formatting, the display in step 2 will appear in the display window.



- 7** Press MENU to exit the menu mode.
The window will return to the normal display.
After formatting, three folders are automatically made in the "Memory Stick" (This is the same after inserting a "Memory Stick" for the first time.)

To cancel formatting

Select "NO" in the step 4 or press CANCEL while "OK ?" is displayed in step 5.

Note

You cannot format when the write-protect switch on the "Memory Stick" is set to "LOCK".

48^{GB}

SECTION 2 DISASSEMBLY

Note : This set can be disassemble according to the following sequence.

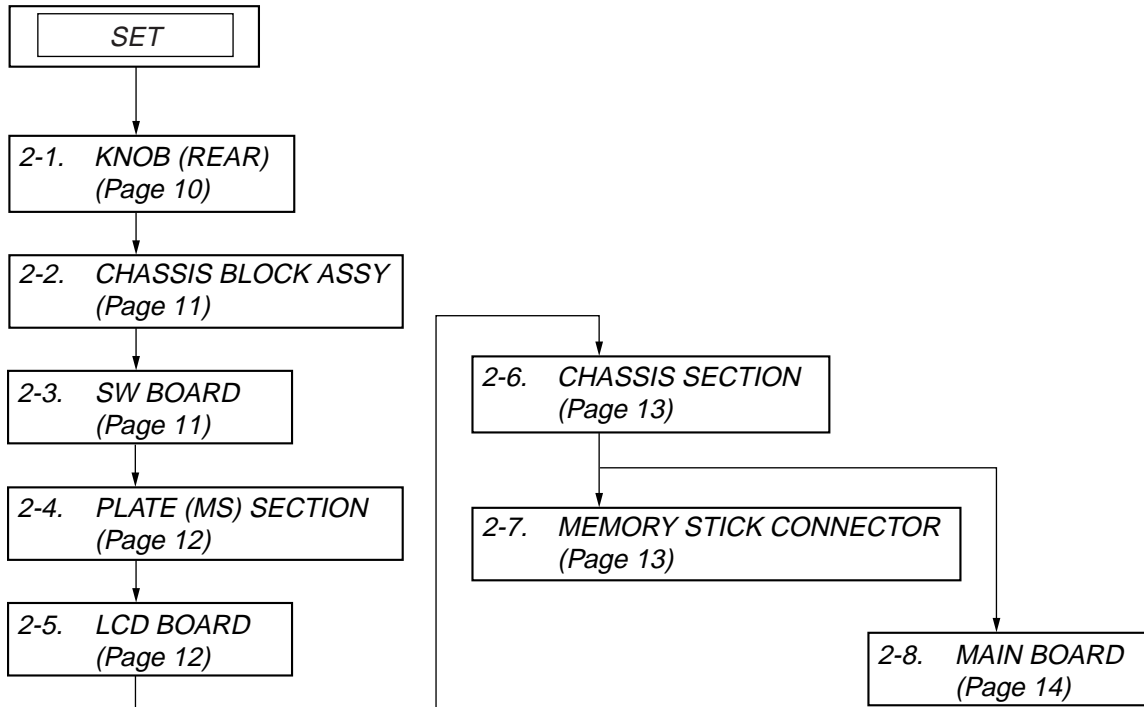

Note : Follow the disassembly procedure in the numerical order given.

2-1. KNOB (REAR)

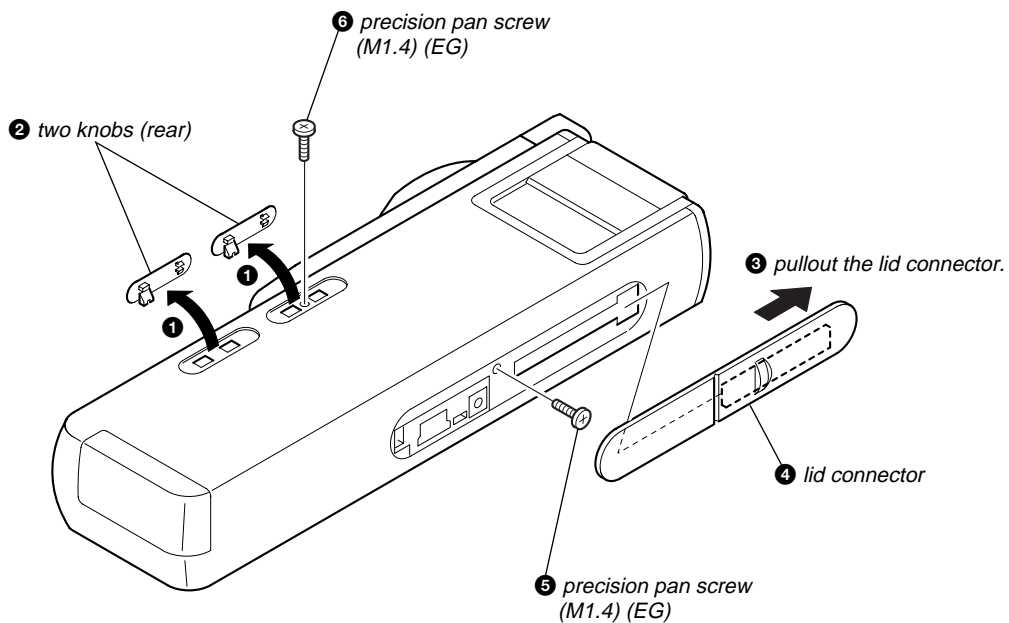

2-2. CHASSIS BLOCK ASSY

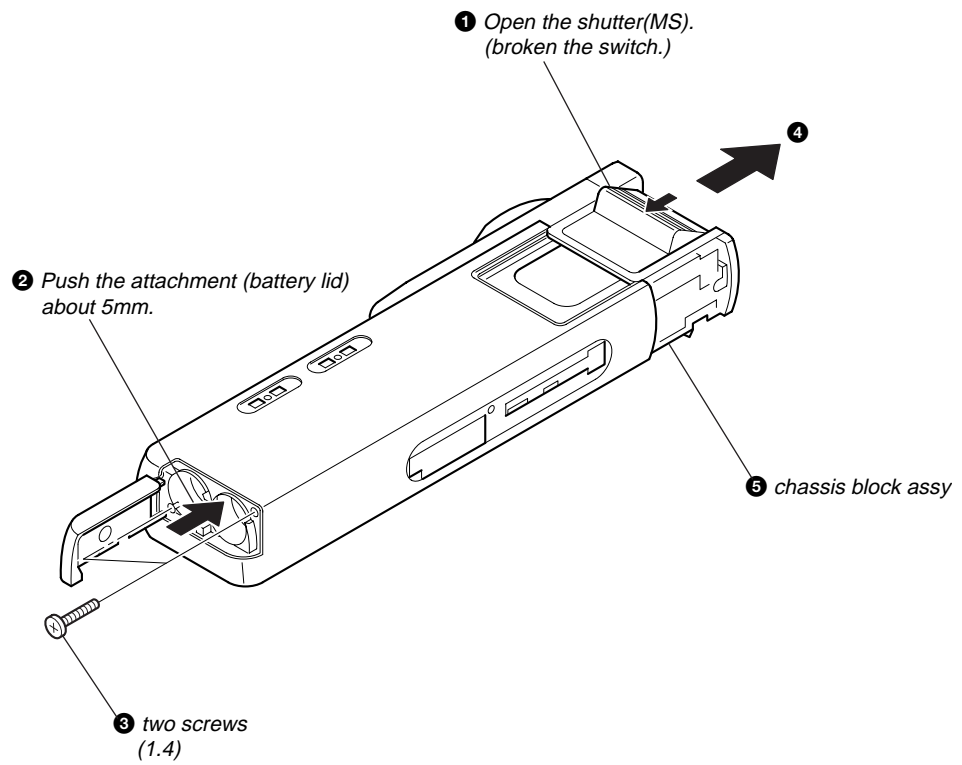

2-3. SW BOARD

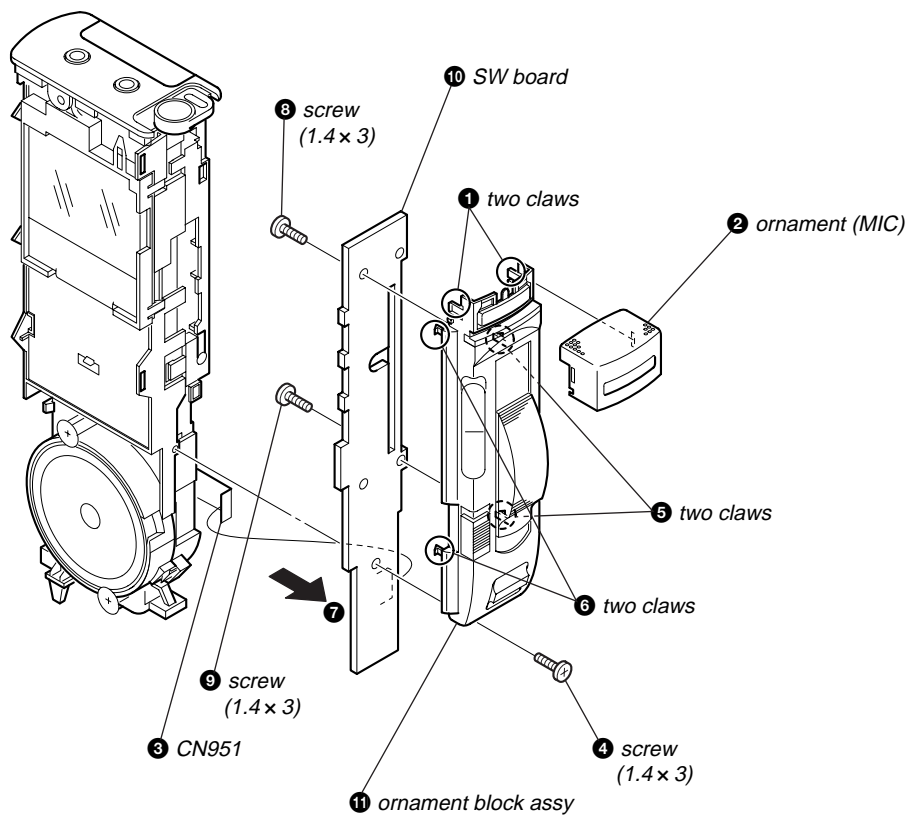

2-4. PLATE (MS) SECTION

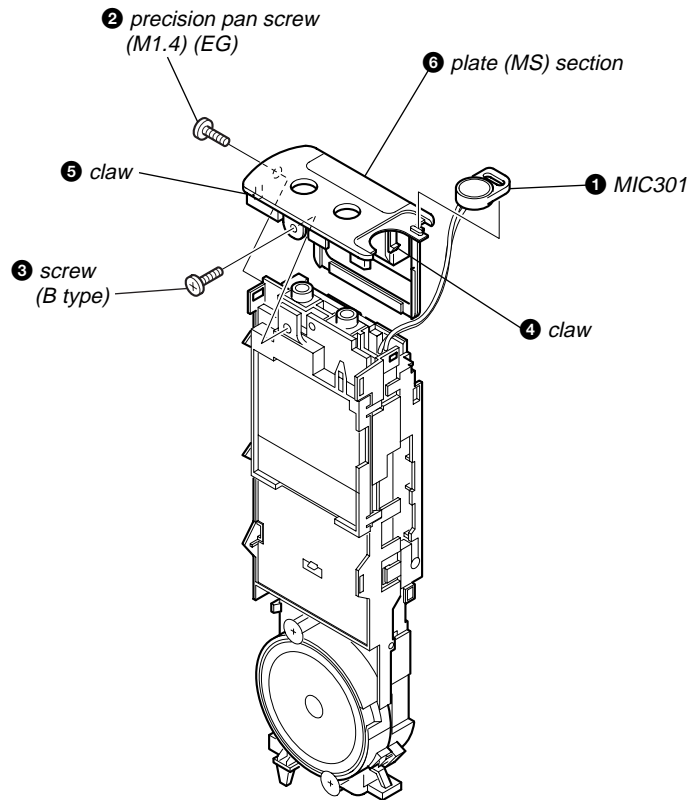

2-5. LCD BOARD

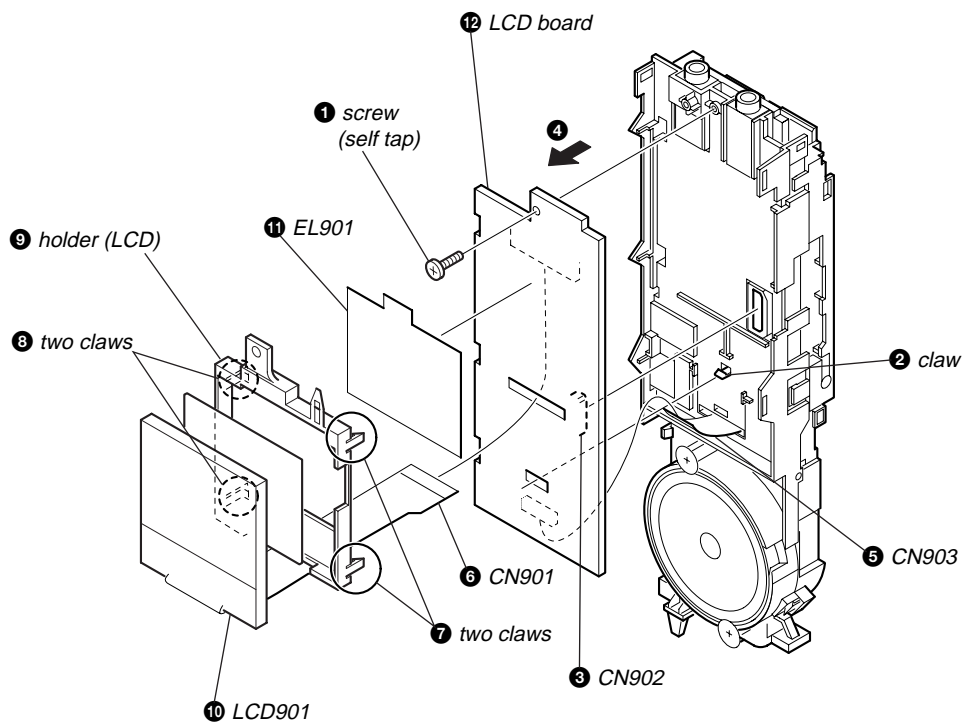

2-6. CHASSIS SECTION

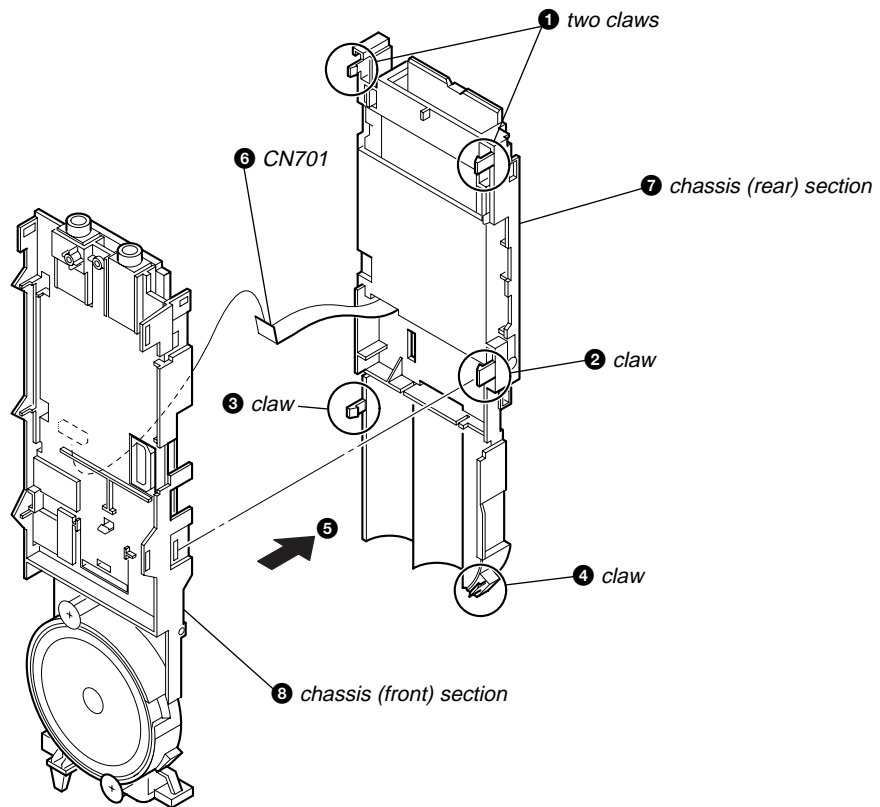

2-7. MEMORY STICK CONNECTOR

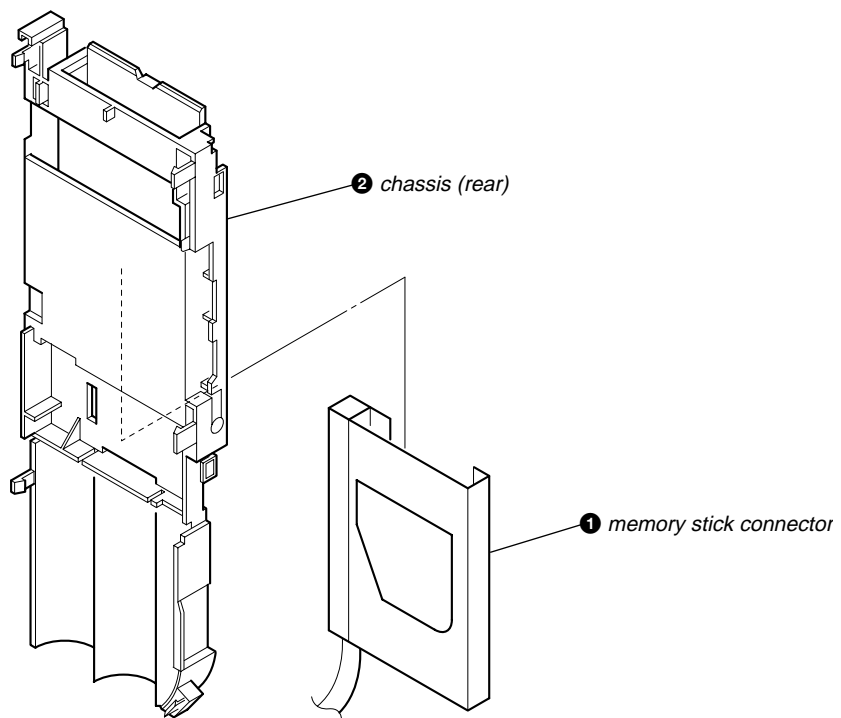

2-8. MAIN BOARD

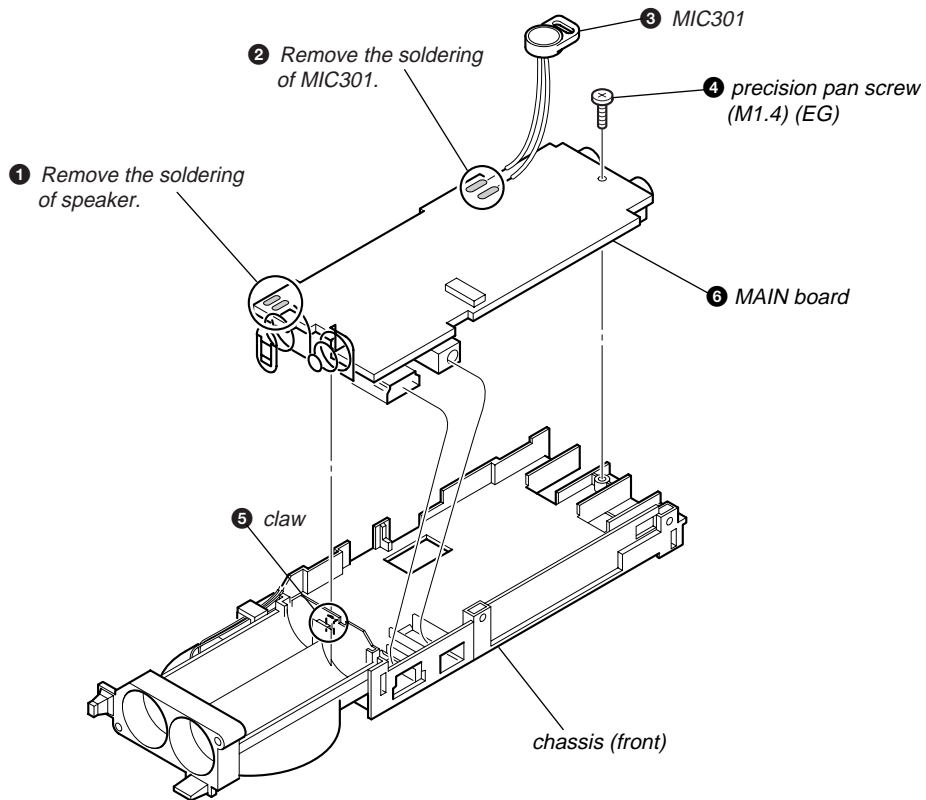

SECTION 3 DIAGRAMS

3-1. IC PIN DESCRIPTIONS

• IC601 μ PD77213F1-101-DA2 (DSP) (MAIN BOARD)

Pin No.	Pin Name	I/O	Pin Description
1 to 3	NC	—	Not used
4	EVDD	—	I/O power supply (3.0 V)
5	XADACS	O	AD/DA chip select
6	ADACCLK	I/O	AD/DA clock
7	ADACDTI	I	AD/DA data input
8	ADACDTO	O	AD/DA data output
9	MICPWR	O	Microphone power supply control
10	GND	—	GND
11	XFMWP	O	Boot flash ROM write protect
12	XFMCS	O	Boot flash ROM chip select
13	MICSENSE	O	Microphone sensitivity select (H: Conference, L: Dictation)
14	GND	—	GND
15	NC	—	Not used
16	EVDD	—	I/O power supply (3.0 V)
17	HD1	I/O	Host data bus (Not used)
18	HD2	I/O	Host data bus (Not used)
19	HD0	I/O	Host data bus (Not used)
20	HD3	I/O	Host data bus (Not used)
21	HD5	I/O	Host data bus (Not used)
22	HD4	I/O	Host data bus (Not used)
23	GND	—	GND
24	IVDD	—	Core power supply (1.5 V)
25	HD7	I/O	Host data bus (Not used)
26	HD6	I/O	Host data bus (Not used)
27	GND	—	GND
28	EVDD	—	I/O power supply (3.0 V)
29	XHCS	I	Host chip select (Pull-up)
30	HA1	I	Host data access 1 (Pull-down)
31	XHWR	I	Host write (Pull-up)
32	HA0	I	Host data access 0 (Pull-down)
33	XHRD	I	Host read (Pull-up)
34	TIMOUT	O	Not used
35	SO	O	Serial data output
36	XHWE	O	Host write enable (Not used)
37	XHRE	O	Host read enable (Not used)
38	GND	—	GND
39	EVDD	—	I/O power supply (3.0 V)
40	BCLK	I/O	Bit clock
41 to 44	NC	—	Not used
45	ADASI	I	ADA serial data input
46	MCLK	I	Master clock
47	LRCLK	I/O	Clock for L-ch and R-ch (H: L-ch, L: R-ch)
48	TSO	O	Time sharing serial data output
49	TSCK	I	Time sharing serial clock input
50	TSOEN	I	Time sharing serial input enable
51	GND	—	GND
52	TSI	I	Time sharing serial data input
53	TSIAK	I	Time sharing serial input response (Not used)
54	TSORQ	O	Time sharing serial output request (Not used)
55	TSIEN	I	Time sharing serial input enable

Pin No.	Pin Name	I/O	Pin Description
56	EVDD	—	I/O power supply (3.0 V)
57	MA1	O	Memory address bus 1 (Not used)
58	MA0	O	Memory address bus 0 (Not used)
59	GND	—	GND
60	IVDD	—	Core power supply (1.5 V)
61	MA2	O	Memory address bus 2 (Not used)
62	MA4	O	Memory address bus 4 (Not used)
63	GND	—	GND
64	MA3	O	Memory address bus 3 (Not used)
65	MA7	O	Memory address bus 7 (Not used)
66	MA5	O	Memory address bus 5 (Not used)
67	MA8	O	Memory address bus 8 (Not used)
68	MA6	O	Memory address bus 6 (Not used)
69	MA9	O	Memory address bus 9 (Not used)
70	MA10	O	Memory address 10 (Not used)
71	GND	—	GND
72	EVDD	—	I/O power supply (3.0 V)
73	MA11	O	Memory address 11 (Not used)
74	MA12	O	Memory address 12 (Not used)
75	MA14	O	Memory address 14 (Not used)
76	MA13	O	Memory address 13 (Not used)
77	MA16	O	Memory address 16 (Not used)
78	MA15	O	Memory address 15 (Not used)
79	EVDD	—	I/O power supply (3.0 V)
80	MA17	O	Memory address 17 (Not used)
81 to 84	NC	—	Not used
85	EVDD	—	I/O power supply (3.0 V)
86	MA18	O	Memory address 18 (Not used)
87	MA19	O	Memory address 19 (Not used)
88	XMHOLDAK	O	Memory bus hold response (Not used)
89	XMRD	O	Memory read-out (Not used)
90	XMHOLDRQ	I	Memory bus hold request (Pull-up)
91	GND	—	GND
92	EVDD	—	I/O power supply (3.0 V)
93	XMWAIT	I	Memory access weight (Pull-up)
94	XMWR	O	Memory write (Not used)
95	GND	—	GND
96	IVDD	—	Core power supply (1.5 V)
97	XMBSTB	O	Memory bus strobe (Not used)
98	MD0	I/O	Memory data bus (Not used)
99	GND	—	GND
100	MD3	I/O	Memory data bus (Not used)
101	MD1	I/O	Memory data bus (Not used)
102	MD4	I/O	Memory data bus (Not used)
103	MD5	I/O	Memory data bus (Not used)
104	MD6	I/O	Memory data bus (Not used)
105	MD2	I/O	Memory data bus (Not used)
106	MD8	I/O	Memory data bus (Not used)
107	GND	—	GND
108	EVDD	—	I/O power supply (3.0 V)
109	MD7	I/O	Memory data bus (Not used)
110	MD13	I/O	Memory data bus (Not used)

Pin No.	Pin Name	I/O	Pin Description
111	MD10	I/O	Memory data bus (Not used)
112	MD11	I/O	Memory data bus (Not used)
113	MD9	I/O	Memory data bus (Not used)
114	MD14	I/O	Memory data bus (Not used)
115	GND	—	GND
116	MD15	I/O	Memory data bus (Not used)
117	MD12	I/O	Memory data bus (Not used)
118	TICE	O	Test ICE
119	TMS	I	Test mode selection
120	EVDD	—	I/O power supply (3.0 V)
121	GND	—	GND
122	TDO	O	Test data output
123 to 126	NC	—	Not used
127	XTRST	I	Test reset
128	TCK	I	Test clock input
129	EVDD	—	I/O power supply (3.0 V)
130	IC	—	Internal connection (Not used)
131	TDI	I	Test data input
132	STOPS	O	Stop (Open)
133	CSTOP	I	Clear stop mode (Pull-down)
134	IC	—	Internal connection (Not used)
135	GND	—	GND
136 and 137	PLL0, PLL1	I	PLL rate setting 0 and 1
138	XRST	I	Reset
139	GND	—	GND
140	IVDD	—	Core power supply (1.5 V)
141	PLL3	I	PLL rate setting 3
142	HALTS	O	HALT
143	GND	—	GND
144 and 145	IVDD	—	Core power supply (1.5 V)
146	PLL2	I	PLL rate setting 2
147	GND	—	GND
148	EVDD	—	I/O power supply (3.0 V)
149	CLKOUT	O	Clock output
150	CLKIN	I	Clock input
151	BOOT1	I	Boot mode 1 (fixed at “H”)
152	GND	—	GND
153	BOOT3	I	Boot mode 3 (fixed at “H”)
154	BOOT0	I	Boot mode 0 (fixed at “H”)
155	GND	—	GND
156	BOOT2	I	Boot mode 2 (fixed at “H”)
157	FMSCK	I/O	Boot flash ROM serial clock
158	TSIOEN	I	SIO enable
159	REQ	O	Request
160	FMSDIO	I/O	Boot flash ROM serial data
161 to 164	NC	—	Not used

• IC701 LC67F5006A-F3A15-E (CPU) (MAIN BOARD)

Pin No.	Pin Name	I/O	Pin Description
1	VSS	—	GND
2	DSPPWR	O	DSP power supply control
3	XOE	O	SRAM output enable, USB read strobe
4	WAKEUP	I	KEY WAKE UP interrupt
5	XDCINDET	I	DC IN detection
6	XUSBIRQ	I	USB driver interrupt request (Not used)
7	XUSBVBUS	I	USB VBUS power supply control
8	DSPIFREQ	I	DSP I/F interrupt request
9	RXD	I	Serial data input (Not used)
10	VSS	—	GND
11	TXD	O	Serial data output (Not used)
12	SCK0	O	Serial clock for DSP I/F
13	SDO0	O	Serial data output for DSP I/F
14	SDI0	I	Serial data input for DSP I/F
15	XSRCS	O	SRAM chip select
16	XWE	O	SRAM write enable
17	XUB	O	Higher byte enable for SRAM
18	XLDCS	O	Chip select for LCD driver I/F
19	CIVDD	—	I/O power supply 3.1 V
20	XUSBCS	O	Chip select for USB (Not used)
21	LCDSCK	O	Serial clock for LCD driver I/F
22	LCDDO	O	Serial data output for LCD driver I/F
23	SCK1	O	Serial clock for RTC and EEPROM
24	SDO1	O	Serial data output for RTC, S/P and EEPROM
25	XLCDRST	O	LCD reset
26 and 27	A15, A16	O	SRAM address bus
28	CCVDD	—	Core power supply 2.6 V
29	SIPCLK	O	Clock for S/P
30	BEEP	O	Beep
31	DREQ	I	USB DMA request input
32	POWERSW	I	POWER switch detection
33	RTCCS	O	Chip select for RTC
34	XADACS	O	Chip select for A/D & D/A converter
35	XDSPSIOEN	O	DSP I/F SIO enable
36	MSLOCK	I	OPEN/CLOSE switch detection
37	MSCLK	O	Clock for Memory Stick
38	MSDIO	I/O	Serial data for Memory Stick
39	MSBS	O	BS for Memory Stick
40	MSINS	I	INS for Memory Stick
41	CIVDD	—	I/O power supply 3.1 V
42	XLB	O	SRAM lower byte enable
43 to 48	A0_A5	O	SRAM and USB address bus
49	A6	O	SRAM address bus
50	VSS	—	GND
51 to 58	A7_A14	O	SRAM address bus
59	CCVDD	—	Core power supply 2.6 V
60	∅	O	System clock output
61	CIVDD	—	I/O power supply 3.1 V
62	CF1	I	CF oscillator pin
63	CF2	O	CF oscillator pin
64	VSS	—	GND

Pin No.	Pin Name	I/O	Pin Description
65	XRST	I	Reset input (L: Reset)
66	XSTBY	I	Standby (L: HW standby)
67	BOOT	I	Boot pin, not used. (set at "L")
68 to 75	D0_D7	I/O	SRAM and USB data bus
76	Vss	—	GND
77 to 84	D8_D15	I/O	SRAM and USB data bus
85	AVss	—	GND for A/D
86 to 88	KE0, KEY1, KEY2	I	Key entry 0, 1, and 2
89	VORDPC	I	VOR & DPC switch detection
90	MICSENS	I	MIC SENS switch detection
91	BATTAD	I	Battery voltage detection
92	JACKDET	I	Microphone & headphone jack detection
93	SDI1	I	Serial data input for RTC and EEPROM
94	VREF	I	Reference voltage for A/D (3.1 V)
95	AVcc	I	Power supply for A/D (3.1 V)
96 to 98	MD0_MD2	I	Mode pin
99	TEST	I	Test pin
100	CCVDD	—	Core power supply 2.6 V

MEMO

3-2. BLOCK DIAGRAM — MAIN SECTION —

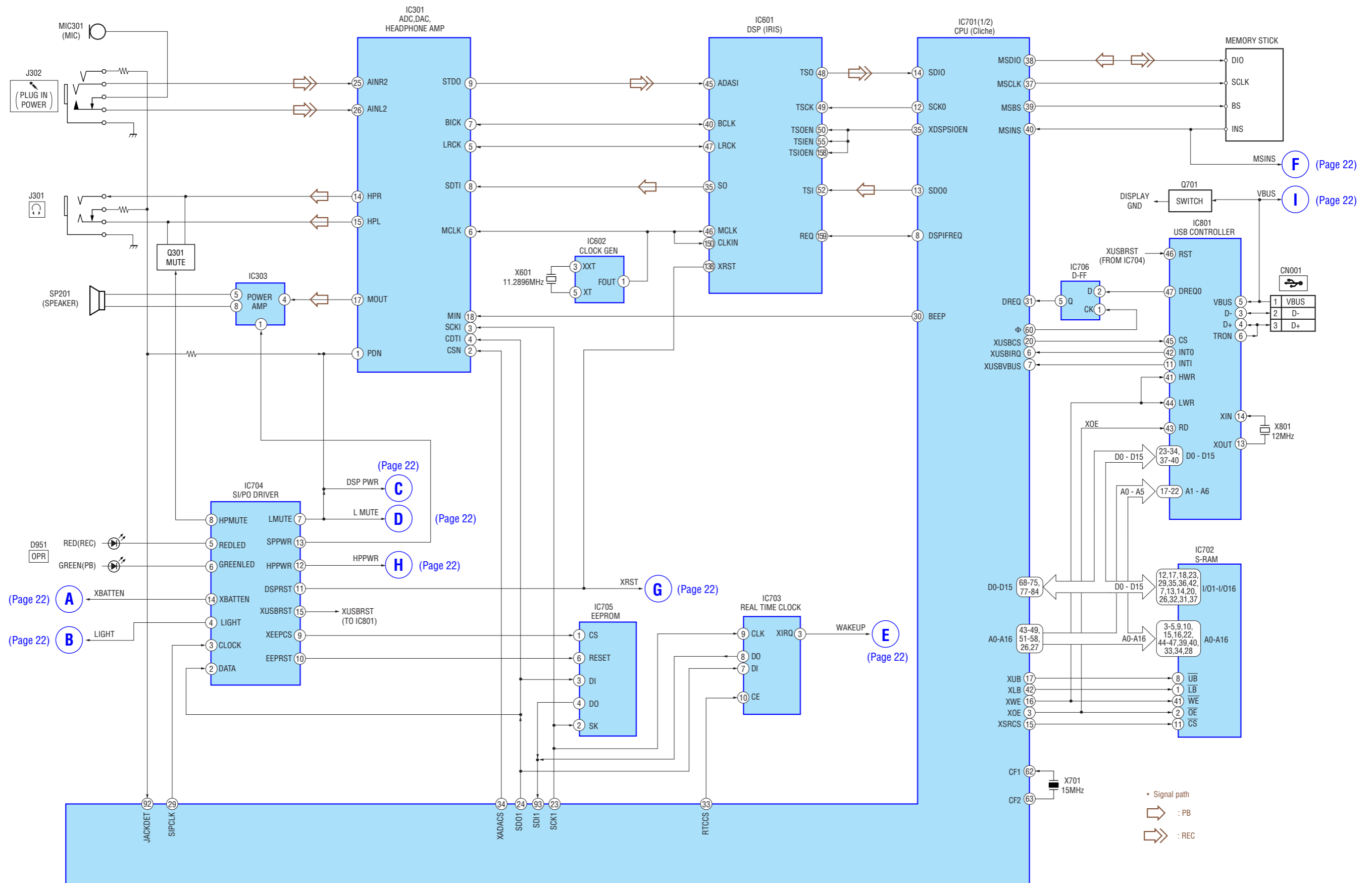

3-3. BLOCK DIAGRAM — LCD/SW SECTION —

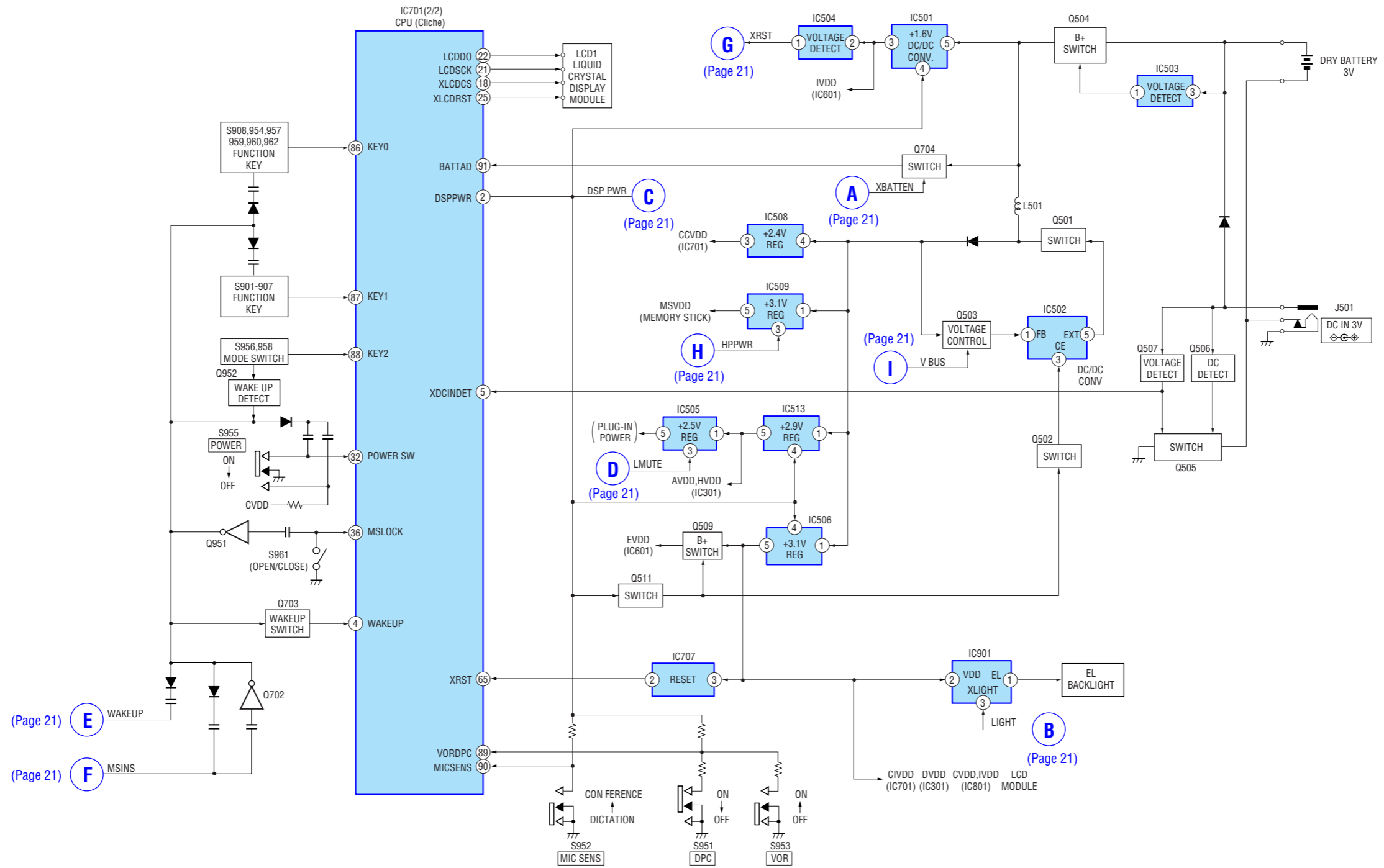

THIS NOTE IS COMMON FOR PRINTED WIRING BOARDS AND SCHEMATIC DIAGRAMS.
 (In addition to this, the necessary note is printed in each block.)

Common Note on Schematic Diagrams:

- All capacitors are in μF unless otherwise noted. (p: pF)
- 50 WV or less are not indicated except for electrolytics and tantalums.
- All resistors are in Ω and $\frac{1}{4}W$ or less unless otherwise specified.
- Δ : internal component.
- \square : panel designation.
- **—** : B+ Line.
- Power voltage is dc 3V and fed with regulated dc power supply from battery terminal.
- Voltage and waveforms are dc with respect to ground under no-signal (detuned) conditions.
- no mark : PB
- * : Impossible to measure
- Voltages are taken with a VOM (Input impedance 10 M Ω). Voltage variations may be noted due to normal production tolerances.
- Waveforms are taken with a oscilloscope. Voltage variations may be noted due to normal production tolerances.
- Circled numbers refer to waveforms.
- Signal path.
- \Rightarrow : PB
- $\Rightarrow\Rightarrow$: REC

* IC601, IC702 on main board are not replaceable.

- The voltages and Waveform of CSP (chip size package) cannot be measured, because its lead layout is different from that of conventional IC.

Common Note on Printed Wiring Boards:

- \circ — : parts extracted from the component side.
- — : parts extracted from the conductor side.
- Δ : internal component.
- \bullet : Through hole.
- \square : Pattern from the side which enables seeing.

Caution:
 Pattern face side: Parts on the pattern face side seen from the pattern face are indicated. (SIDE B)
 Parts face side: Parts on the parts face side seen from the parts face are indicated. (SIDE A)

* IC601, IC702 on main board are not replaceable.

- Lead Layouts

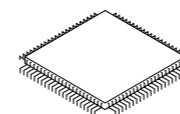

Lead layout of conventional IC

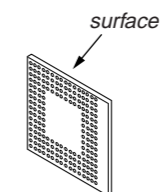

CSP (chip size package)

• Waveforms

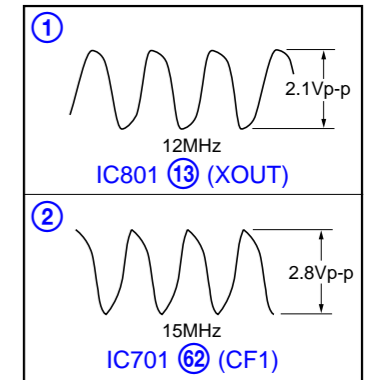

3-4. PRINTED WIRING BOARD — MAIN SECTION —  : Uses unleaded solder.

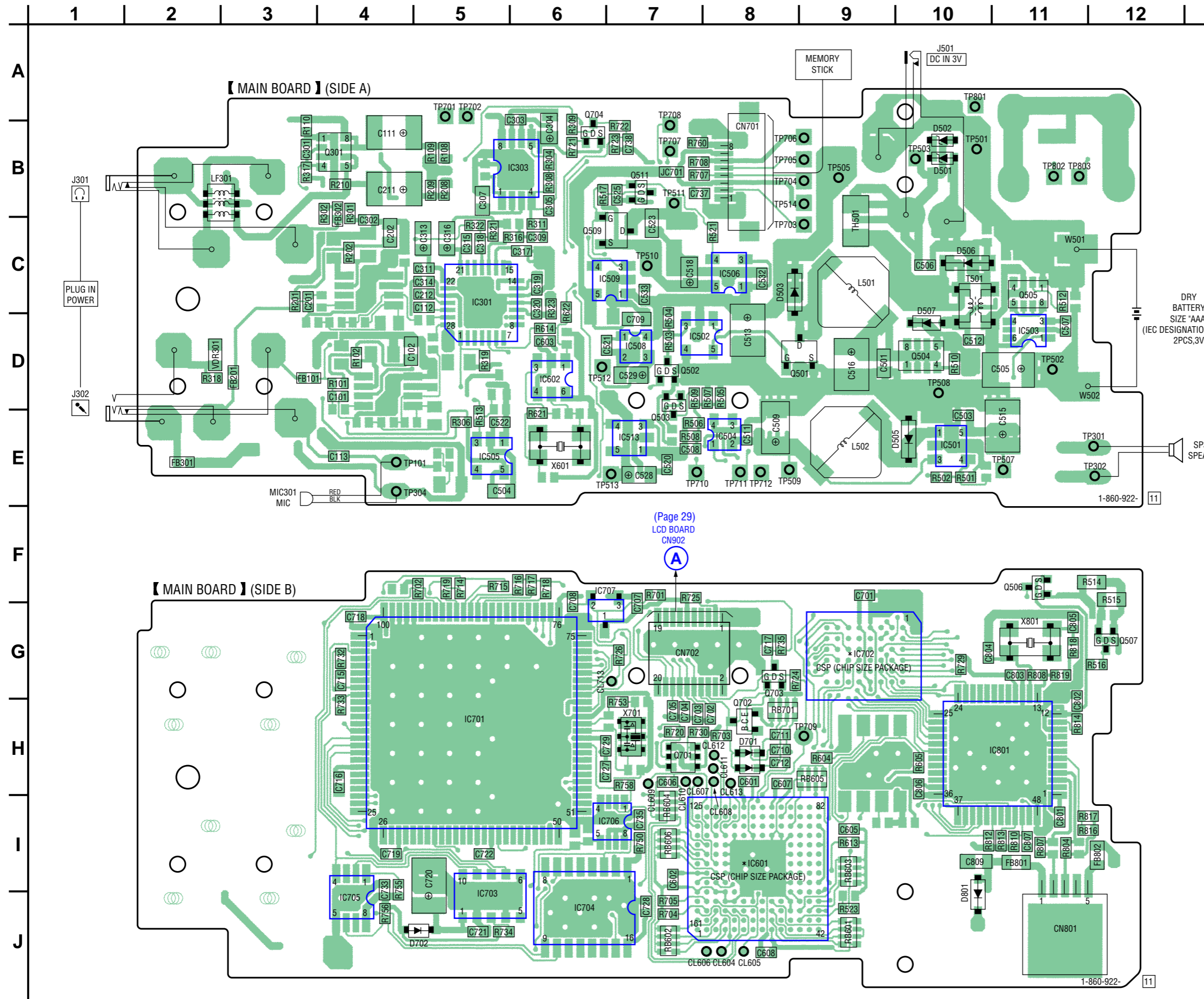

• Semiconductor Location

Ref. No.	Location
D501	B-10
D502	B-10
D503	C-8
D505	E-10
D506	C-10
D507	C-10
D701	H-8
D702	J-5
D801	J-10
IC301	C-5
IC303	B-6
IC501	E-10
IC502	D-7
IC503	D-11
IC504	E-8
IC505	E-5
IC506	C-8
IC508	D-7
IC509	C-7
IC513	E-7
IC601	I-8
IC602	D-6
IC701	H-5
IC702	G-9
IC703	J-5
IC704	J-6
IC705	J-4
IC706	I-7
IC707	G-6
IC801	H-11
Q301	B-4
Q501	D-8
Q502	D-7
Q503	E-7
Q504	D-10
Q505	C-11
Q506	F-11
Q507	G-12
Q509	C-7
Q511	B-7
Q701	H-7
Q702	H-8
Q703	G-8
Q704	B-6

(Page 29)
LCD BOARD
CN902
A

3-5. SCHEMATIC DIAGRAM — MAIN SECTION (1/3) — Refer to page 23 for Waveform. Refer to page 31 for IC Block Diagrams.

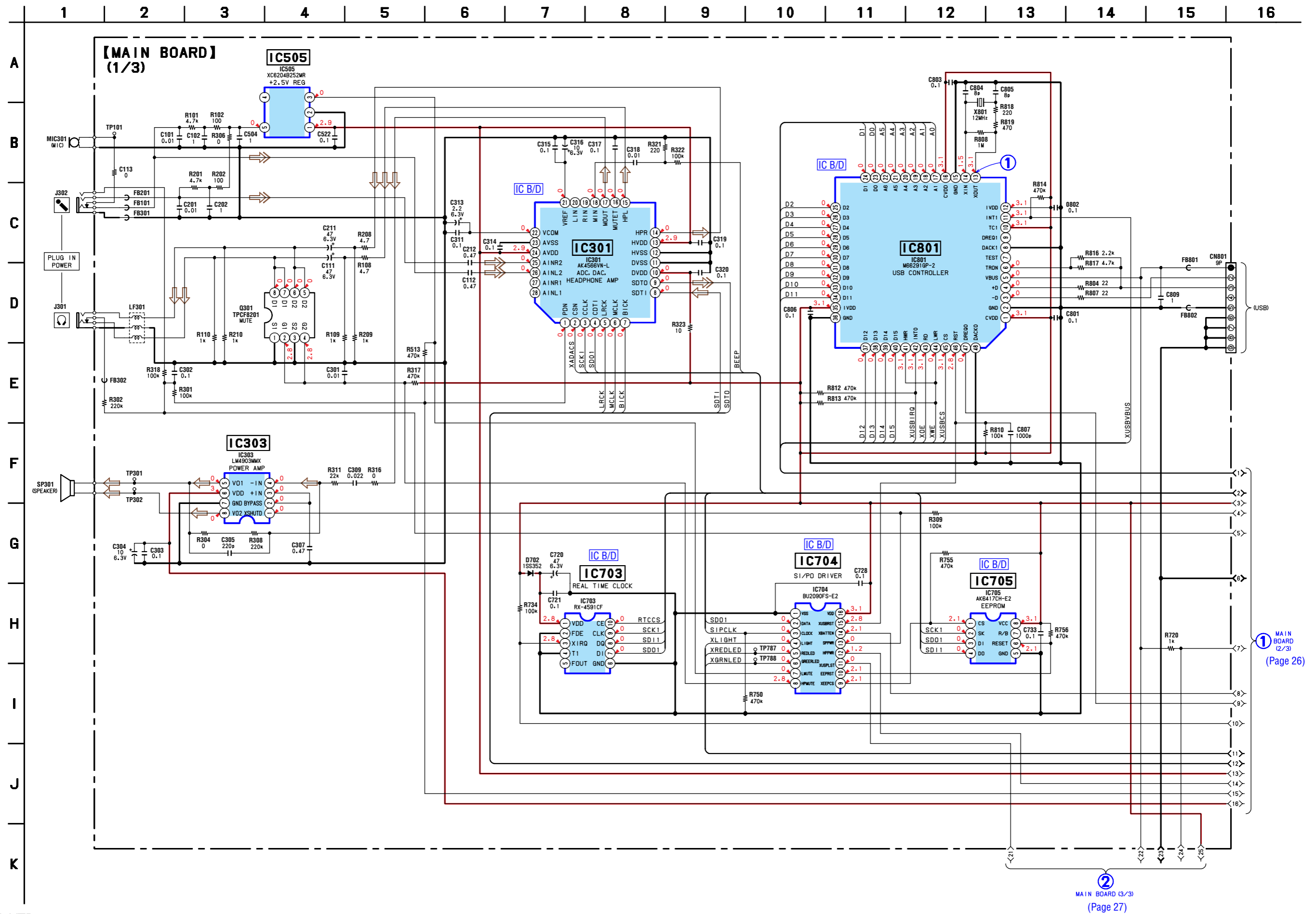

1 MAIN BOARD (2/3) (Page 26)

2 MAIN BOARD (3/3) (Page 27)

3-6. SCHEMATIC DIAGRAM — MAIN SECTION (2/3) —

• Refer to page 18 for IC Pin Descriptions.

• Refer to page 23 for Waveform.

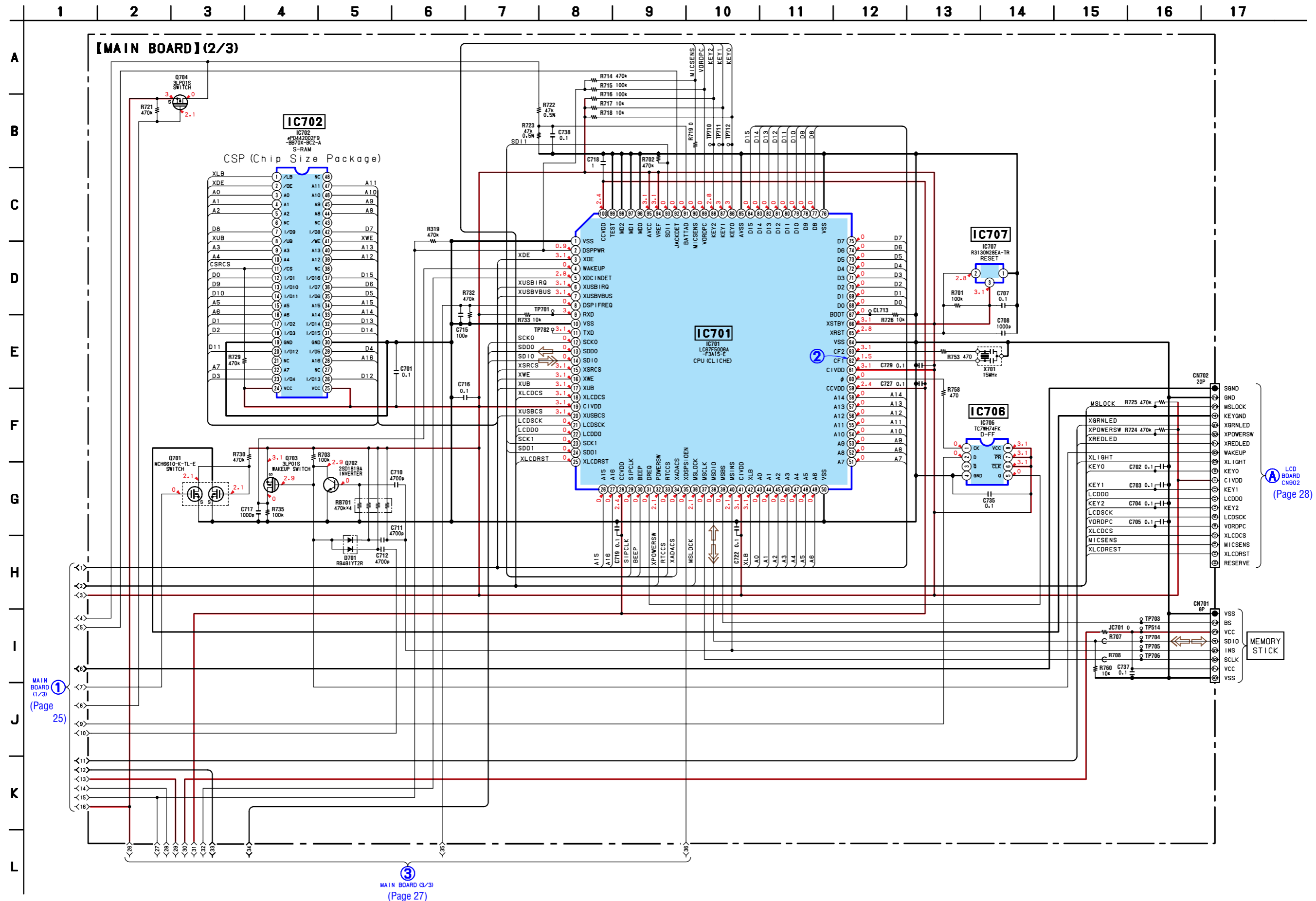

LCD BOARD CN902 (Page 28)

MEMORY STICK

MAIN BOARD (3/3) (Page 27)

MAIN BOARD (1/3) (Page 25)

3-7. SCHEMATIC DIAGRAM — MAIN SECTION (3/3) — • Refer to page 15 for IC Pin Descriptions.

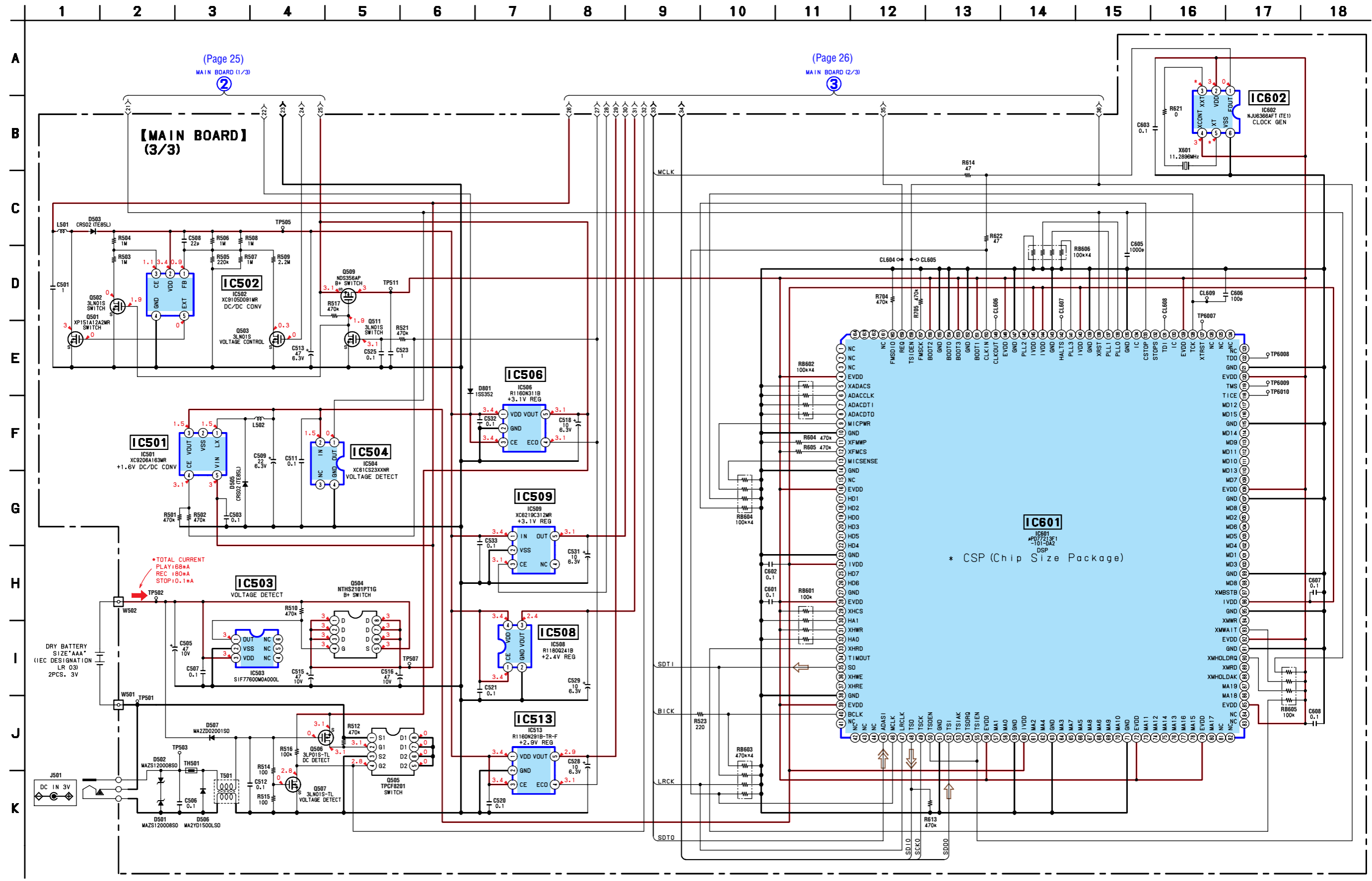

3-8. SCHEMATIC DIAGRAM — LCD/SW SECTION —

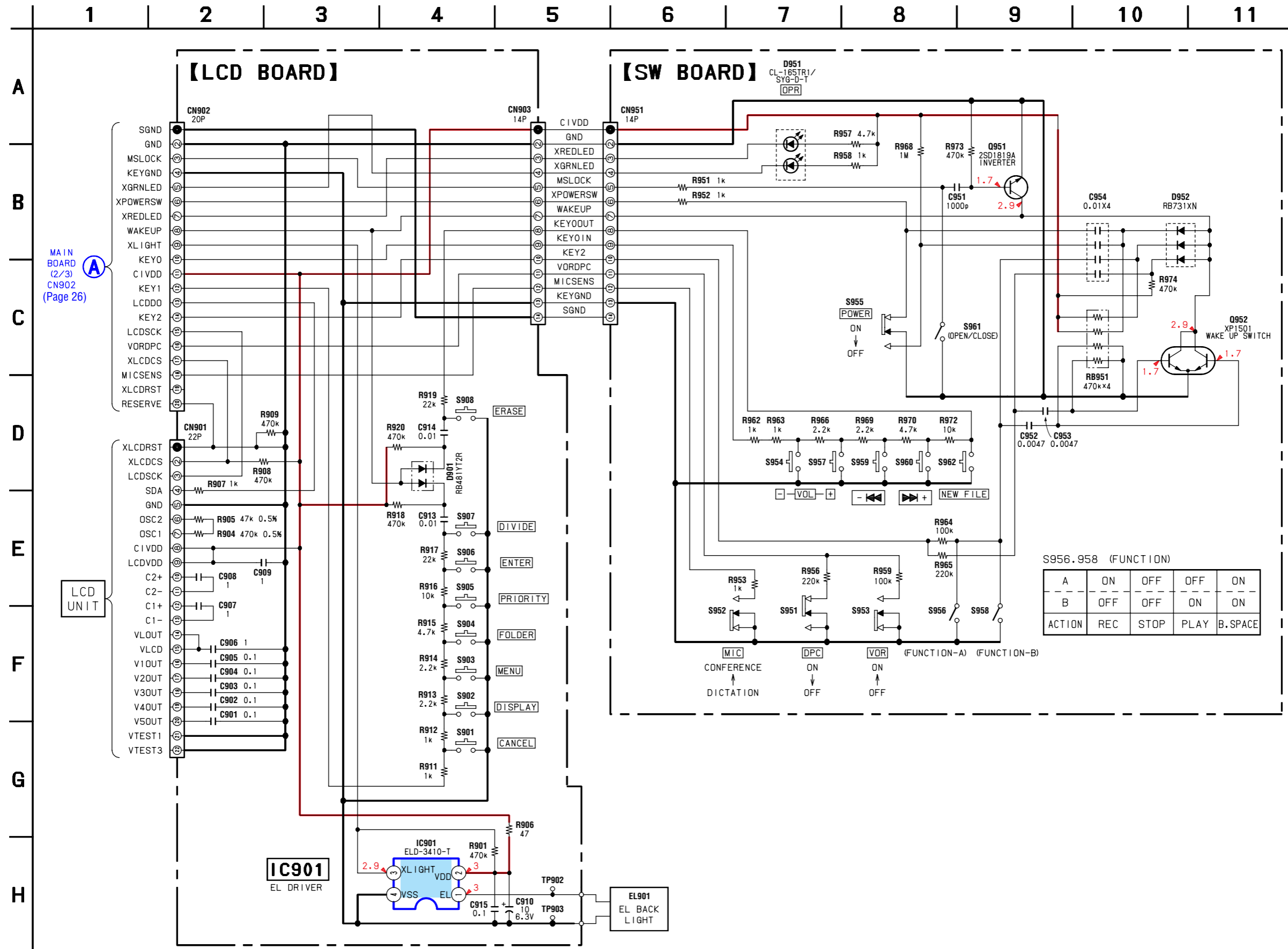

3-9. PRINTED WIRING BOARD — LCD SECTION —  : Uses unleaded solder.

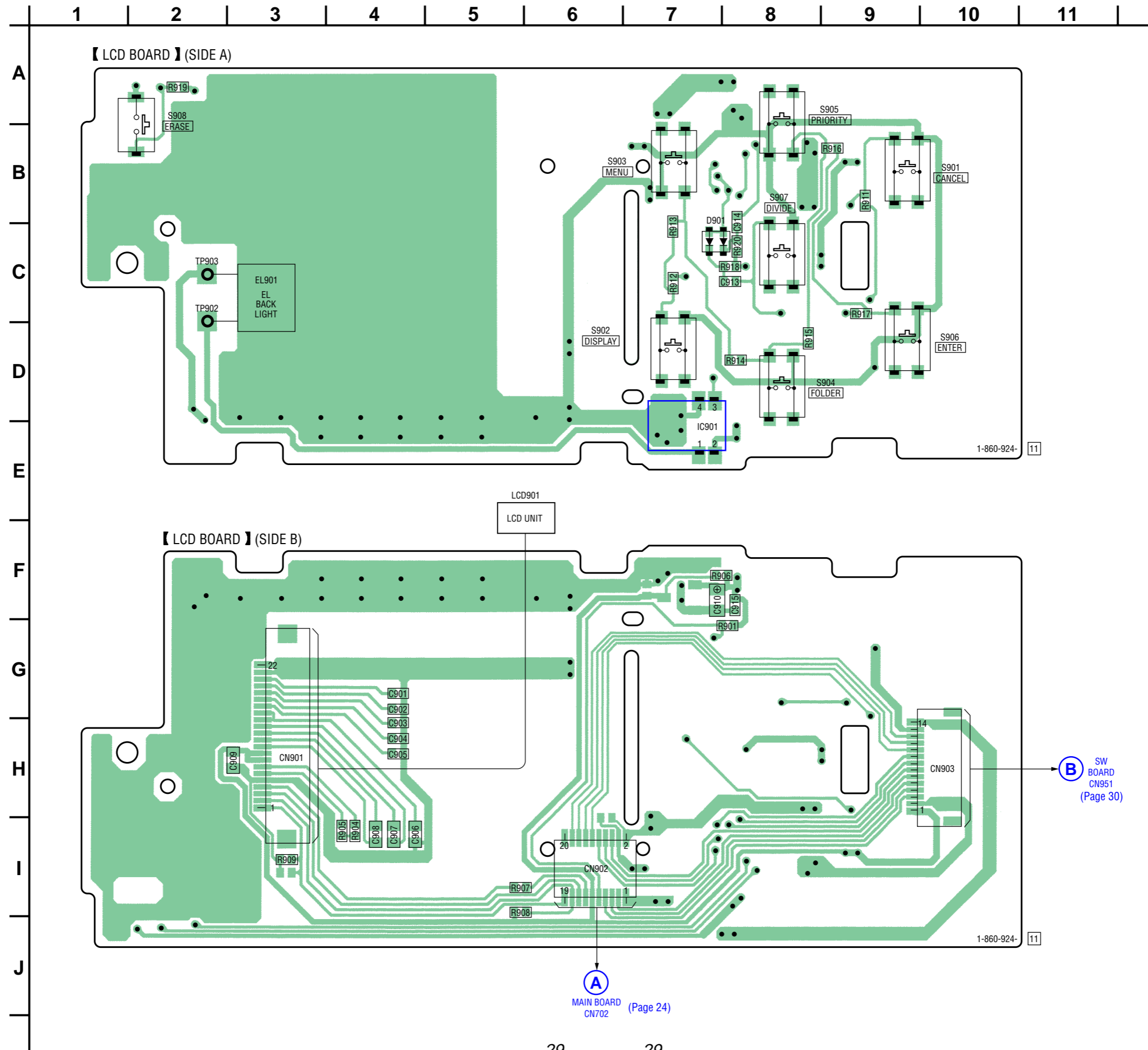

3-10. PRINTED WIRING BOARD — SW SECTION —  : Uses unleaded solder.

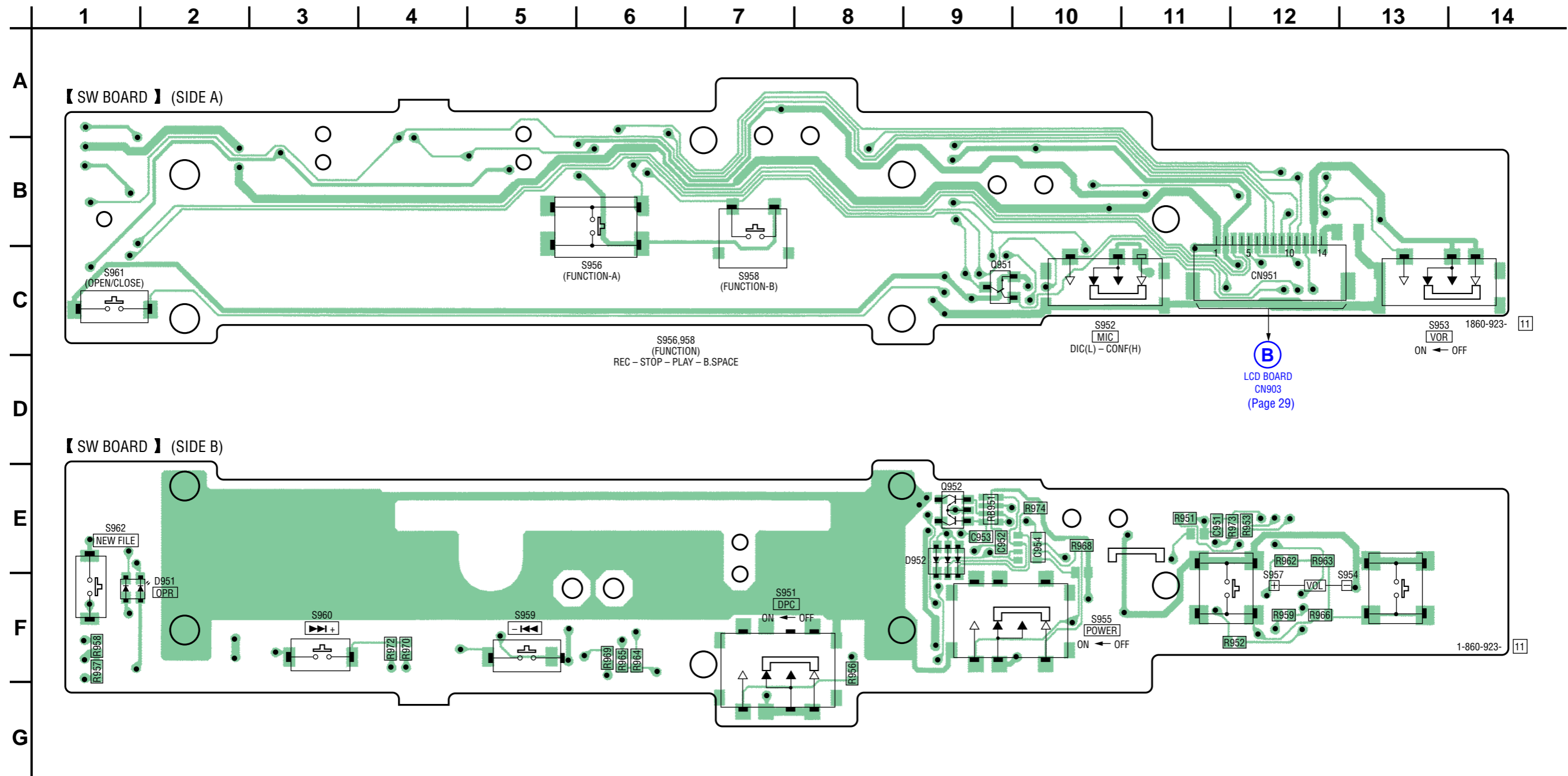

• IC BLOCK DIAGRAMS

IC301 AK4566VN-L (MAIN Board (1/3))

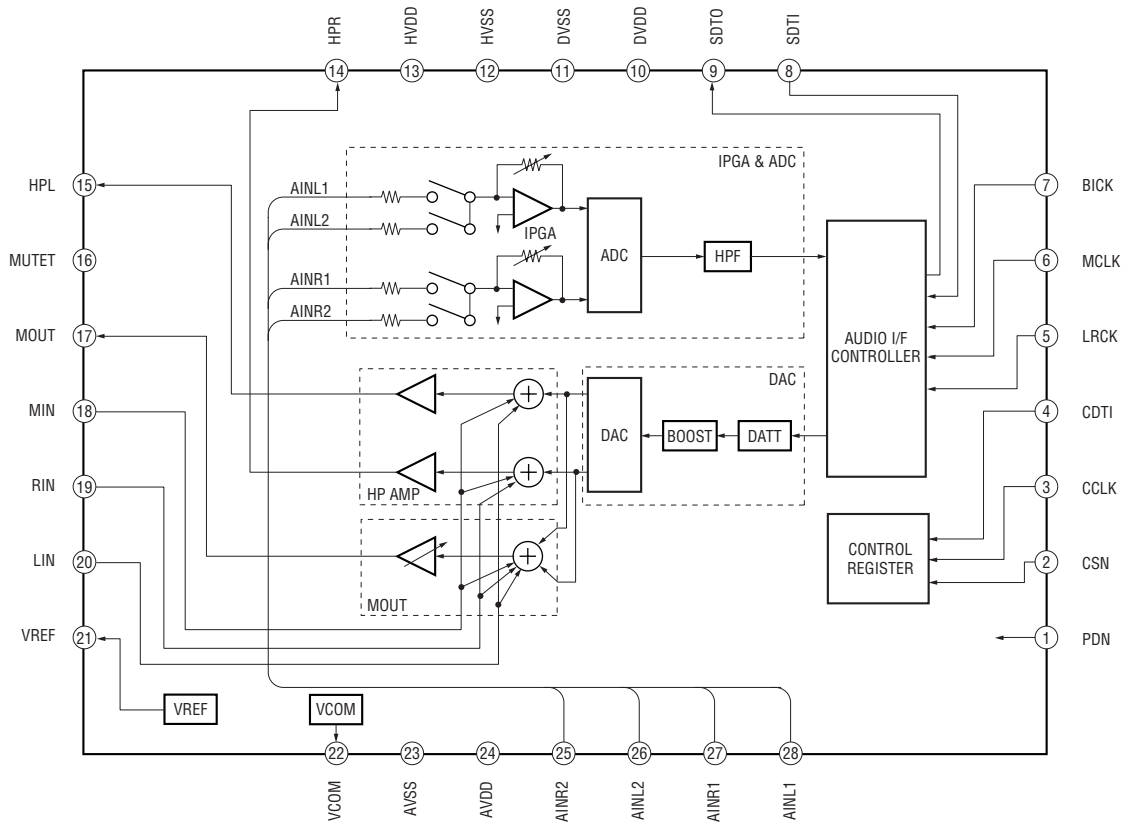

IC703 RX-4591CF (MAIN Board (1/3))

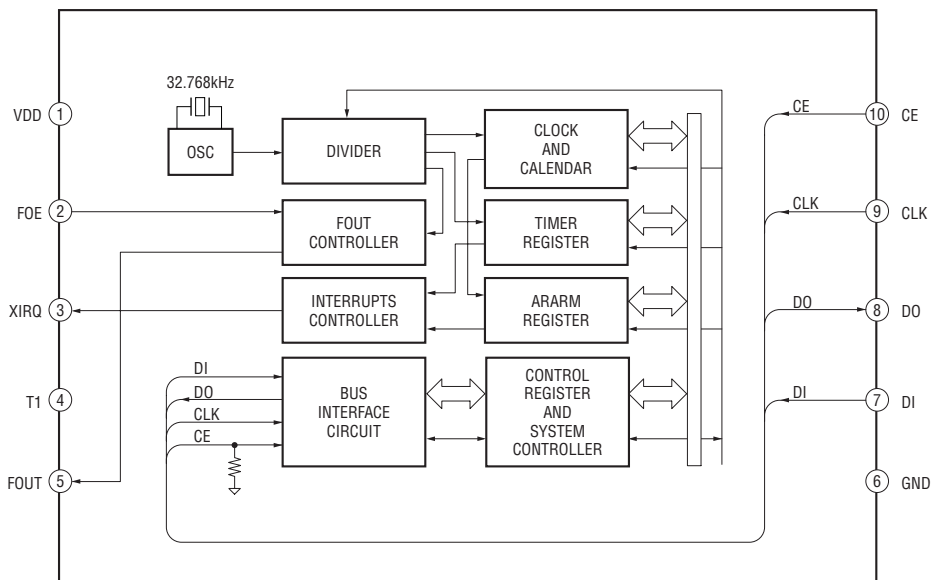

ICD-BM1VTP

IC704 BU2090FS-E2 (MAIN Board (1/3))

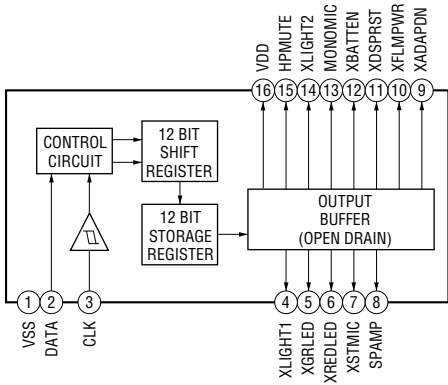

IC705 AK6417CH-E2 (MAIN Board (1/3))

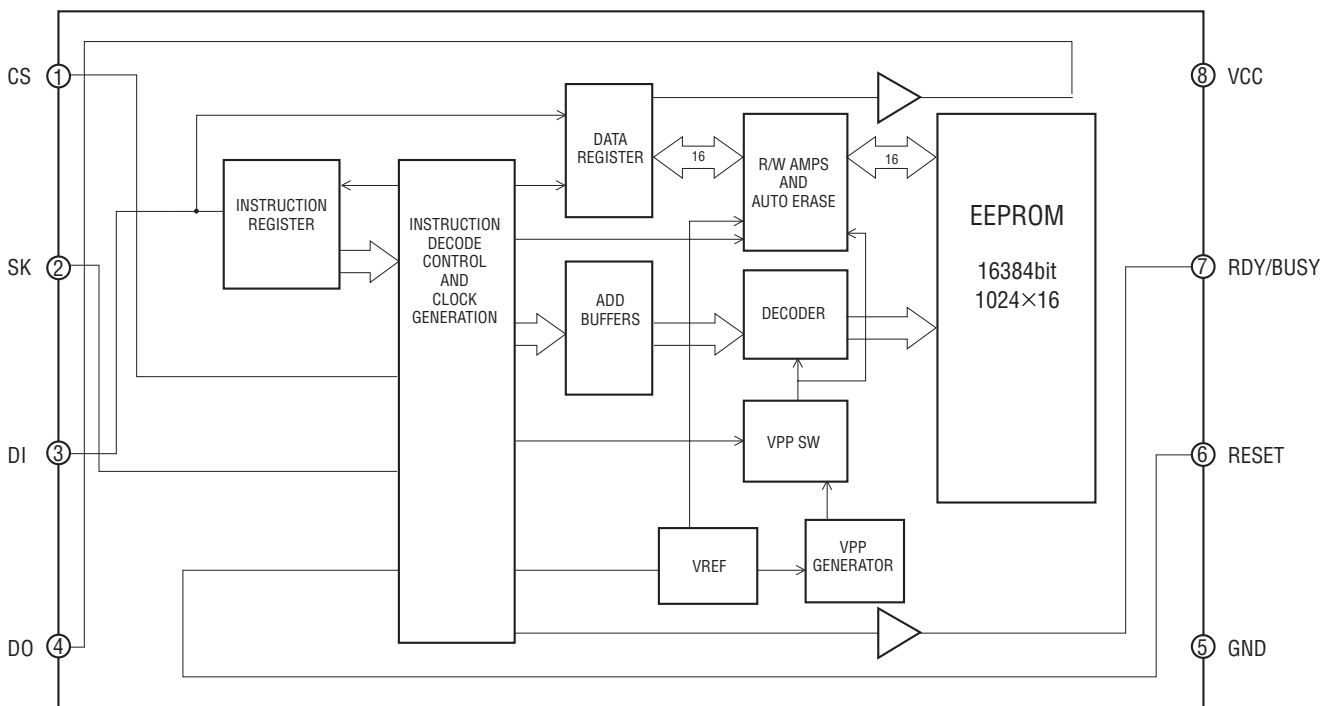

IC801 M66291GP-2 (MAIN Board (1/3))

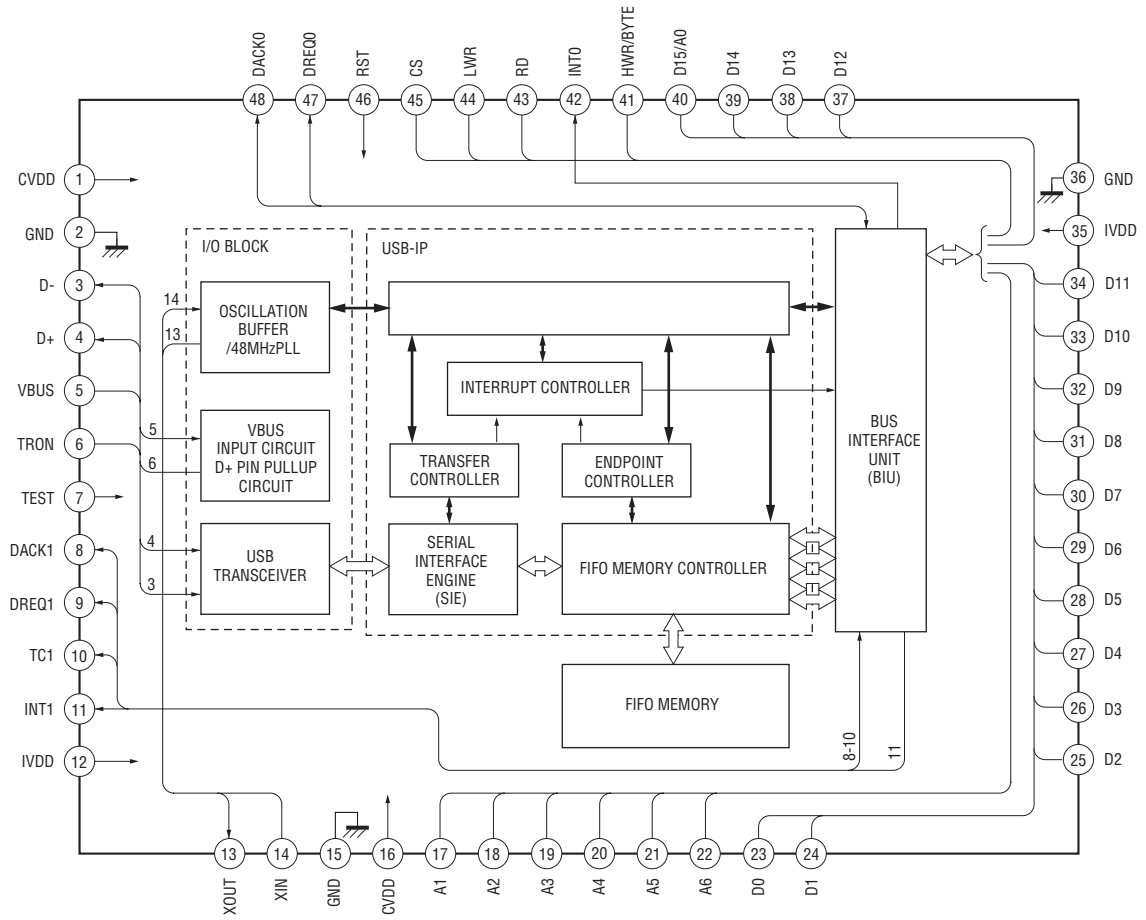

SECTION 4 EXPLODED VIEWS

NOTE:

- The mechanical parts with no reference number in the exploded views are not supplied.
- Items marked “*” are not stocked since they are seldom required for routine service. Some delay should be anticipated when ordering these items.

- Color Indication of Appearance Parts
Example :
 KNOB, BALANCE (WHITE) ... (RED)
 ↑ ↑
 Parts Color Cabinet's Color
- Accessories are given in the last of this parts list.

4-1. MAIN SECTION

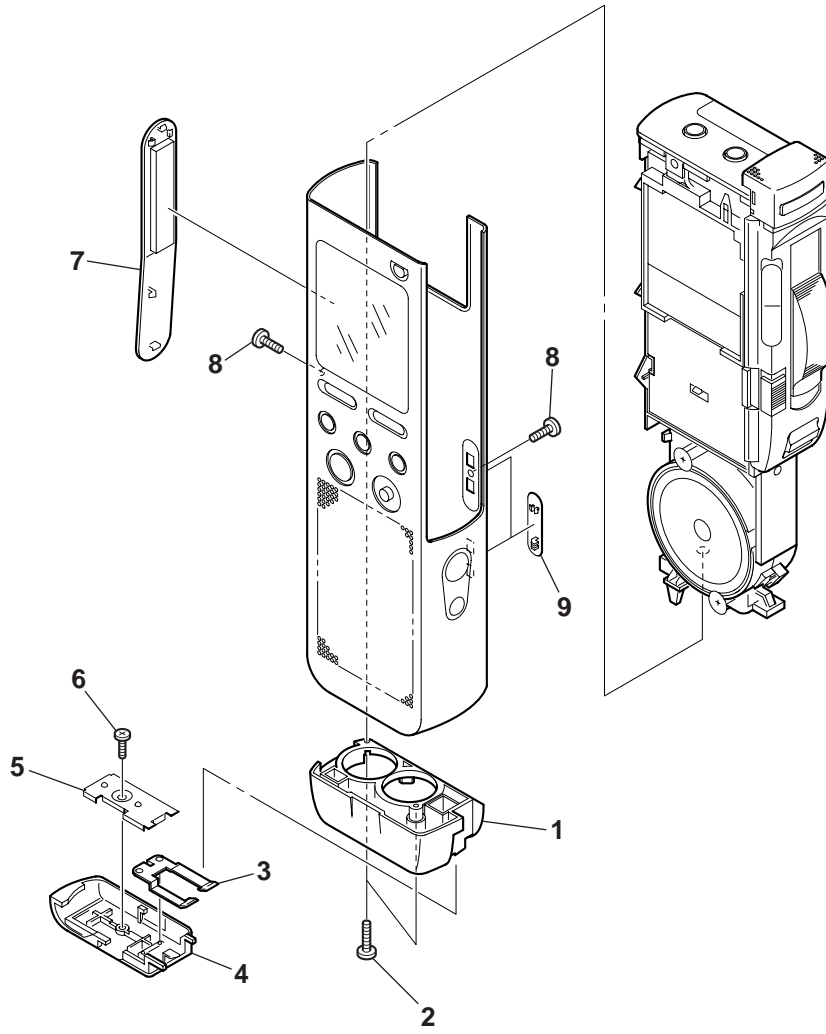

Ref. No.	Part No.	Description	Remark	Ref. No.	Part No.	Description	Remark
1	3-260-469-01	ATTACHMENT (BATTERY LID)		6	3-248-370-01	SCREW, SELF TAP	
2	3-252-824-11	SCREW (1.4)		7	3-260-459-01	CONNECTOR, LID	
3	3-260-472-01	HINGE (BATTERY LID)		8	3-225-996-12	SCREW (M1.4) (EG), PRECISION PAN	
4	3-260-475-02	LID, BATTERY CASE		9	3-260-462-01	KNOB (REAR)	
5	3-260-471-01	TERMINAL (+/-), BATTERY					

4-2. CASE SECTION

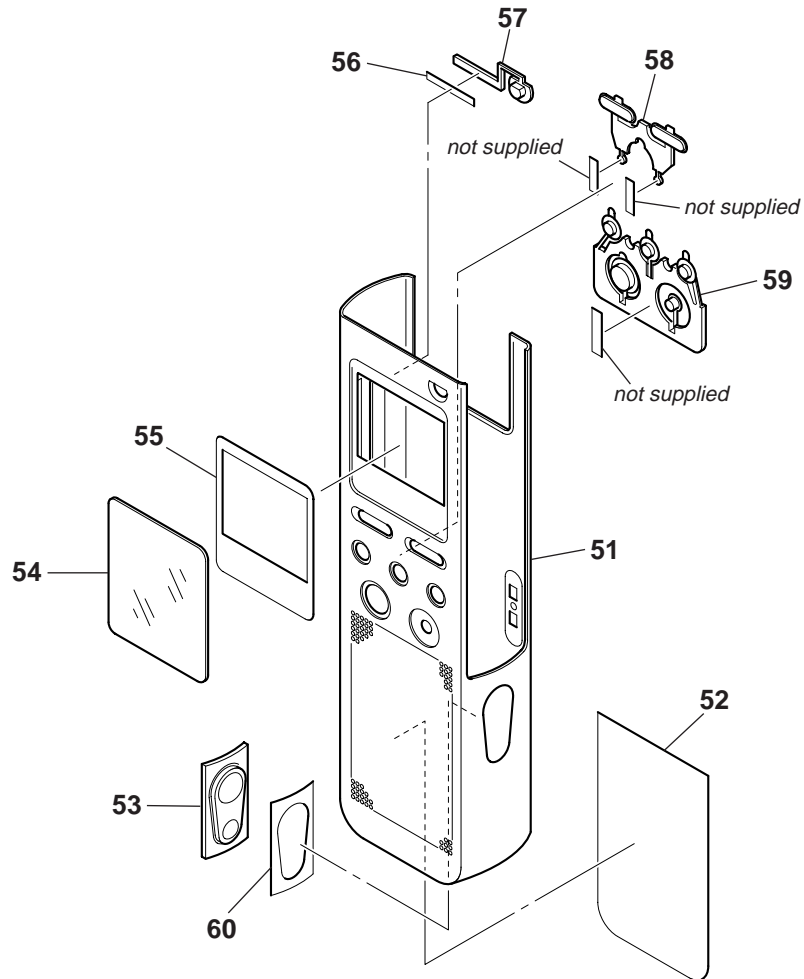

Ref. No.	Part No.	Description	Remark	Ref. No.	Part No.	Description	Remark
51	3-260-497-01	CASE		56	3-260-506-01	SHEET (ERASE), ADHESIVE	
52	3-260-425-01	NET (SPEAKER)		57	3-260-435-01	BUTTON (ERASE)	
53	3-260-436-01	BUTTON (VOL)		58	3-261-295-01	BUTTON (FRONT) (B)	
54	3-260-461-01	WINDOW (LCD)		59	3-260-426-01	BUTTON (FRONT) (A)	
55	3-260-460-02	SHEET (WINDOW), ADHESIVE		60	3-260-498-01	SHEET (CASE), ADHESIVE	

4-3. ORNAMENT SECTION

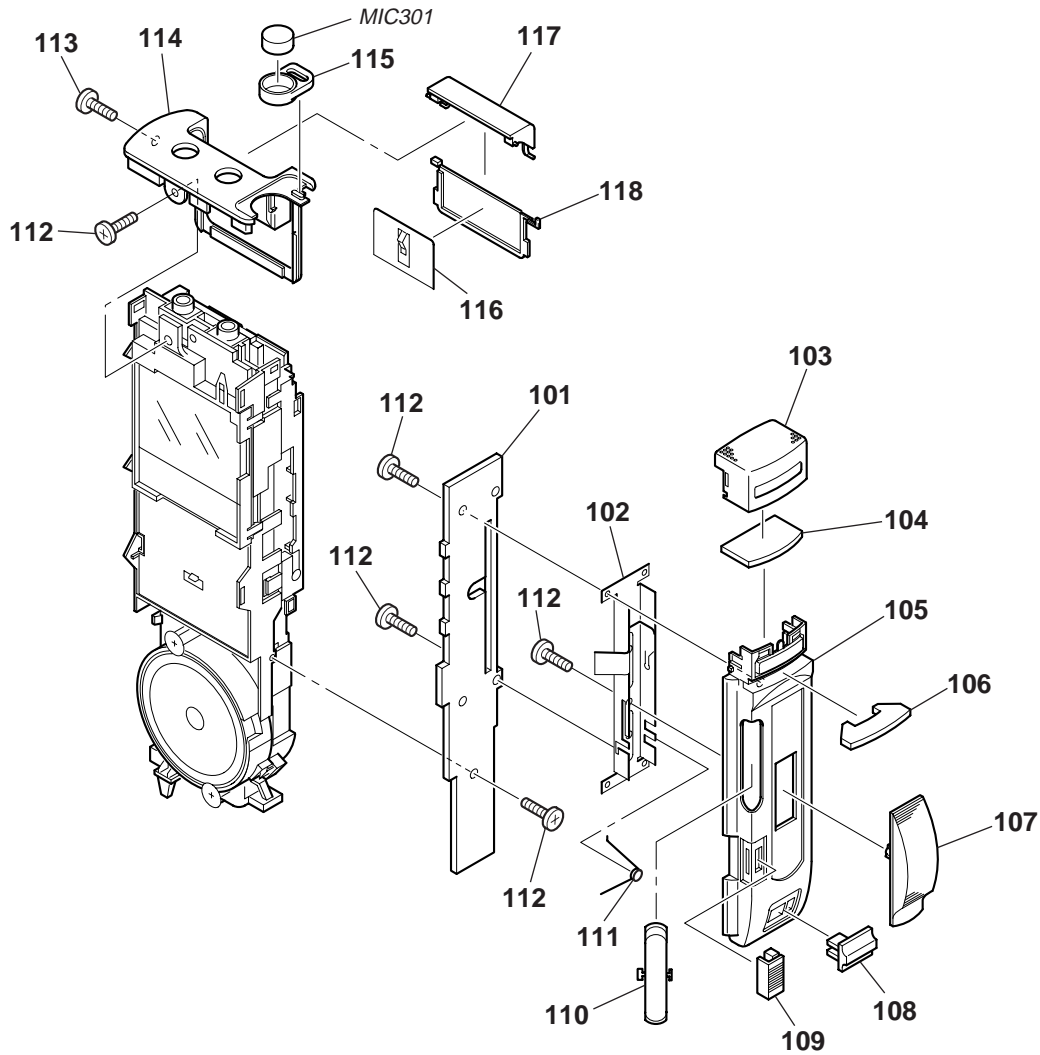

Ref. No.	Part No.	Description	Remark	Ref. No.	Part No.	Description	Remark
* 101	A-4541-673-A	SW BOARD, COMPLETE		111	3-260-525-01	SPRING (REVIEW), TORSION	
102	X-3384-213-1	SLIDE ASSY		112	3-247-180-01	SCREW (1.4X3)	
103	3-260-481-01	ORNAMENT (MIC)		113	3-225-996-12	SCREW (M1.4) (EG), PRECISION PAN	
104	3-260-545-01	FILTER (MIC)		114	3-260-488-01	FRAME (MS)	
105	3-260-529-01	ORNAMENT (SLIDE)		115	3-260-546-01	CUSHION, MICROPHONE	
106	3-260-544-01	WINDOW (LED)		116	3-260-482-01	PLATE (MS)	
107	3-260-527-01	KNOB (SLIDE)		117	3-260-484-01	SHUTTER (MS)	
108	3-260-523-01	KNOB (POWER)		118	3-260-483-01	SLIDER (MS)	
109	3-260-522-01	KNOB (DPC)		MIC301	1-542-572-11	MICROPHONE, ELECTRET CAP (Mic)	
110	3-260-526-01	BUTTON (F/R)					

4-4. CHASSIS (1) SECTION

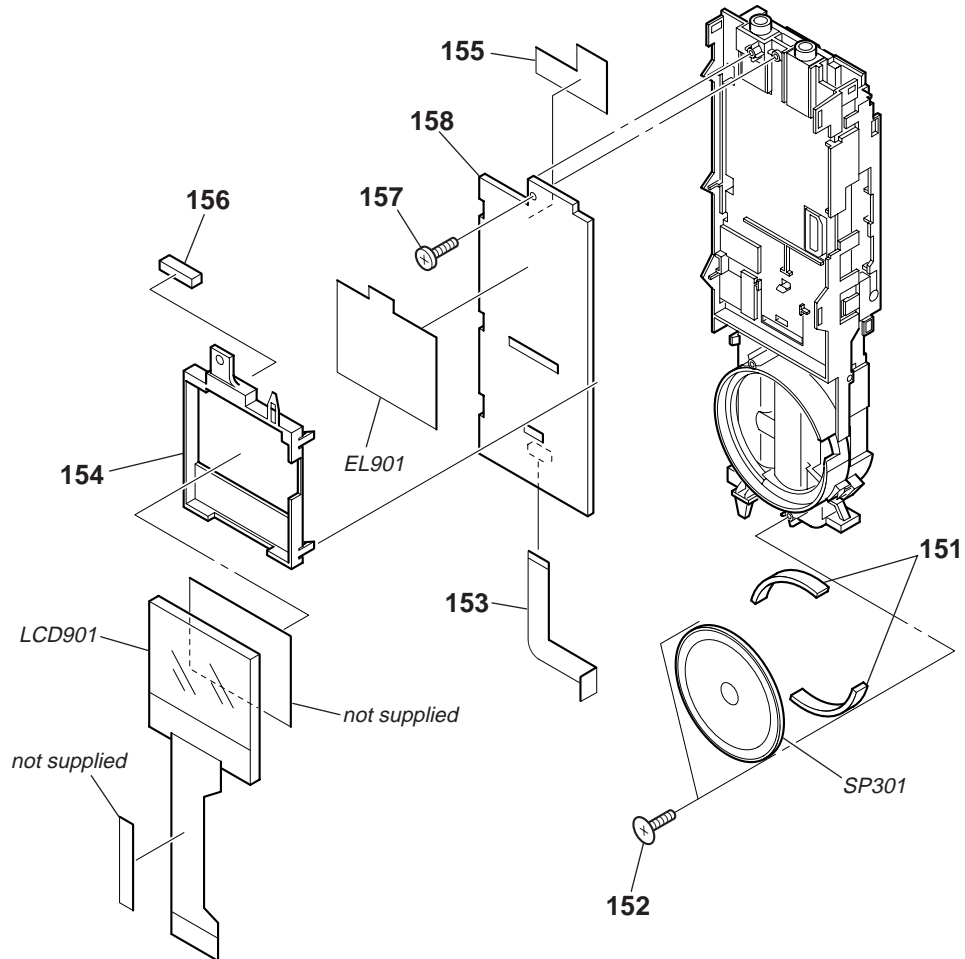

Ref. No.	Part No.	Description	Remark	Ref. No.	Part No.	Description	Remark
151	3-260-479-01	CUSHION (SPEAKER)		157	3-248-370-01	SCREW, SELF TAP	
152	3-963-156-01	SCREW (BTP1.7X3), SPECIAL		* 158	A-4541-671-A	LCD BOARD, COMPLETE	
153	1-860-925-11	FLEXIBLE BOARD		EL901	1-805-472-11	ELEMENT, EL	
154	3-260-504-01	HOLDER (LCD)		LCD901	1-477-070-11	INDICATOR UNIT, LIQUID CRYSTAL	
155	3-261-078-01	SHEET (JACK)		SP301	1-825-645-11	SPEAKER (2.8cm)	
156	3-260-501-01	CUSHION (EL)					

4-5. CHASSIS (2) SECTION

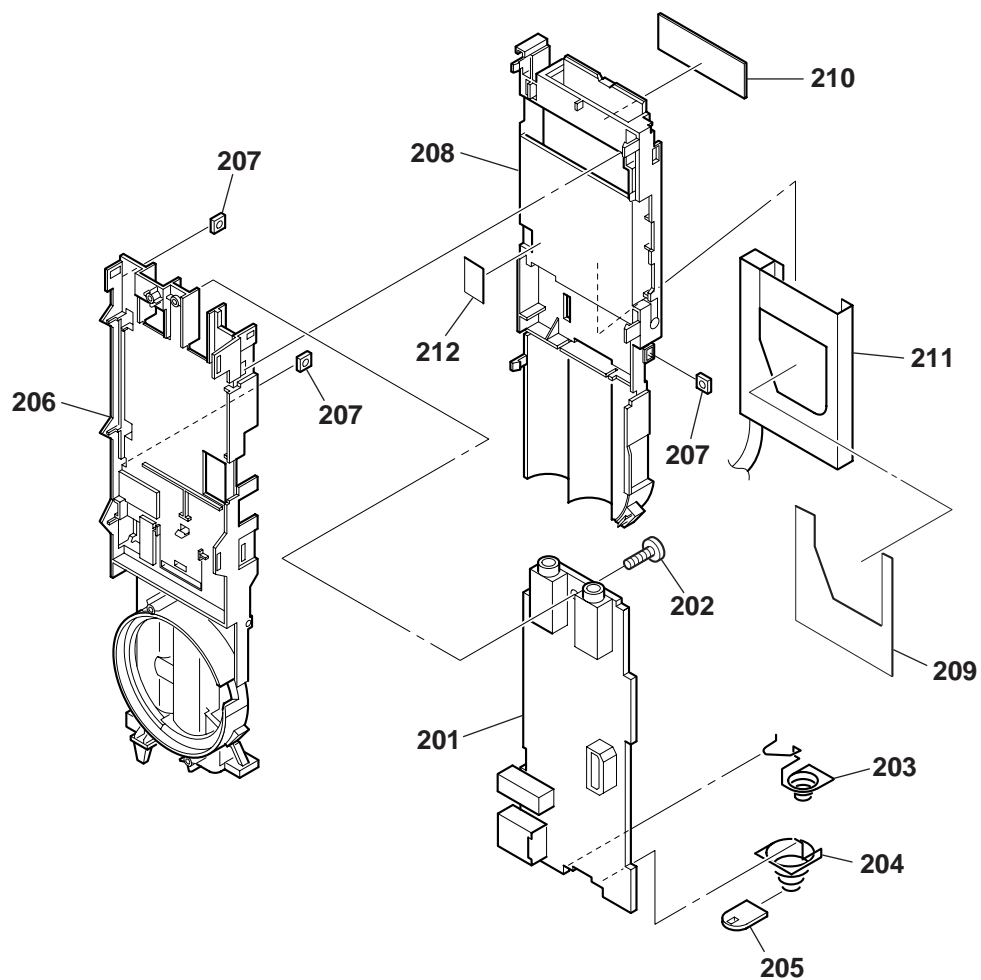

Ref. No.	Part No.	Description	Remark	Ref. No.	Part No.	Description	Remark
* 201	A-4541-666-A	MAIN BOARD, COMPLETE		207	3-221-591-01	NUT (M1.4)	
202	3-225-996-12	SCREW (M1.4) (EG), PRECISION PAN		208	3-260-489-01	CHASSIS (REAR)	
203	3-260-477-01	TERMINAL (-), BATTERY		209	3-260-480-01	SHEET (MS), ADHESIVE	
204	3-260-478-01	TERMINAL (+), BATTERY		210	3-260-486-01	WINDOW (MS)	
205	3-250-332-01	CAP (TERMINAL)		211	1-818-067-11	CONNECTOR, MEMORY STICK	
206	3-260-491-01	CHASSIS (FRONT)		212	3-261-081-01	SHEET (CONNECTOR)	

SECTION 5
ELECTRICAL PARTS LIST

LCD MAIN

NOTE:

- Due to standardization, replacements in the parts list may be different from the parts specified in the diagrams or the components used on the set.
-XX and -X mean standardized parts, so they may have some difference from the original one.
RESISTORS
All resistors are in ohms.
METAL: Metal-film resistor.
METAL OXIDE: Metal oxide-film resistor.
F: nonflammable

- Items marked "*" are not stocked since they are seldom required for routine service. Some delay should be anticipated when ordering these items.
SEMICONDUCTORS
In each case, u : μ, for example:
uA.. : μA.. uPA.. : μPA..
uPB.. : μPB.. uPC.. : μPC.. uPD.. : μPD..
CAPACITORS
uF : μF
COILS
uH : μH

When indicating parts by reference number, please include the board.

Table with columns: Ref. No., Part No., Description, Remark. Includes parts like LCD BOARD, COMPLETE; CERAMIC CHIP; TANTAL. CHIP; CONNECTOR; DIODE; IC; RESISTOR; RES-CHIP; METAL CHIP; etc.

ICD-BM1VTP

MAIN

Ref. No.	Part No.	Description	Remark	Ref. No.	Part No.	Description	Remark
C320	1-125-777-11	CERAMIC CHIP	0.1uF 10% 10V	C801	1-125-777-11	CERAMIC CHIP	0.1uF 10% 10V
C501	1-125-837-11	CERAMIC CHIP	1uF 10% 6.3V	C802	1-125-777-11	CERAMIC CHIP	0.1uF 10% 10V
C503	1-125-777-11	CERAMIC CHIP	0.1uF 10% 10V	C803	1-125-777-11	CERAMIC CHIP	0.1uF 10% 10V
C504	1-125-837-11	CERAMIC CHIP	1uF 10% 6.3V	C804	1-164-848-11	CERAMIC CHIP	8PF 0.5PF 50V
C505	1-137-934-11	TANTAL. CHIP	47uF 20% 10V	C805	1-164-848-11	CERAMIC CHIP	8PF 0.5PF 50V
C506	1-125-777-11	CERAMIC CHIP	0.1uF 10% 10V	C806	1-125-777-11	CERAMIC CHIP	0.1uF 10% 10V
C507	1-125-777-11	CERAMIC CHIP	0.1uF 10% 10V	C807	1-164-937-11	CERAMIC CHIP	0.001uF 10% 50V
C508	1-164-858-11	CERAMIC CHIP	22PF 5% 50V	C809	1-125-837-11	CERAMIC CHIP	1uF 10% 6.3V
C509	1-137-739-11	TANTAL. CHIP	22uF 20% 6.3V			< CONNECTOR >	
C511	1-125-777-11	CERAMIC CHIP	0.1uF 10% 10V	* CN701	1-815-284-21	CONNECTOR, FPC (ZIF) 8P	
C512	1-125-777-11	CERAMIC CHIP	0.1uF 10% 10V	CN702	1-818-058-21	CONNECTOR, BOARD TO BOARD 20P	
C513	1-165-845-21	TANTAL. CHIP	47uF 20% 6.3V	CN801	1-816-036-41	CONNECTOR (SQUARE TYPE) (USB) 5P	
C515	1-137-934-11	TANTAL. CHIP	47uF 20% 10V			< DIODE >	
C516	1-137-934-11	TANTAL. CHIP	47uF 20% 10V	D501	8-719-056-59	DIODE MAZS120008S0	
C518	1-117-919-11	TANTAL. CHIP	10uF 20% 6.3V	D502	8-719-056-59	DIODE MAZS120008S0	
C520	1-125-777-11	CERAMIC CHIP	0.1uF 10% 10V	D503	8-719-074-47	DIODE CRS02(TE85L)	
C521	1-125-777-11	CERAMIC CHIP	0.1uF 10% 10V	D505	8-719-074-47	DIODE CRS02(TE85L)	
C522	1-125-777-11	CERAMIC CHIP	0.1uF 10% 10V	D506	8-719-081-33	DIODE MA2YD1500LSO	
C523	1-125-837-11	CERAMIC CHIP	1uF 10% 6.3V	D507	8-719-075-93	DIODE MA2ZD02001S0	
C525	1-125-777-11	CERAMIC CHIP	0.1uF 10% 10V	D701	6-500-054-01	DIODE RB481YT2R	
C528	1-117-919-11	TANTAL. CHIP	10uF 20% 6.3V	D702	8-719-016-74	DIODE 1SS352	
C529	1-117-919-11	TANTAL. CHIP	10uF 20% 6.3V	D801	8-719-016-74	DIODE 1SS352	
C531	1-117-919-11	TANTAL. CHIP	10uF 20% 6.3V			< FERRITE BEAD >	
C532	1-125-777-11	CERAMIC CHIP	0.1uF 10% 10V	FB101	1-469-084-21	INDUCTOR, FERRITE BEAD	
C533	1-125-777-11	CERAMIC CHIP	0.1uF 10% 10V	FB201	1-469-084-21	INDUCTOR, FERRITE BEAD	
C601	1-125-777-11	CERAMIC CHIP	0.1uF 10% 10V	FB301	1-469-084-21	INDUCTOR, FERRITE BEAD	
C602	1-125-777-11	CERAMIC CHIP	0.1uF 10% 10V	FB302	1-469-084-21	INDUCTOR, FERRITE BEAD	
C603	1-125-777-11	CERAMIC CHIP	0.1uF 10% 10V	FB801	1-500-282-11	INDUCTOR, FERRITE BEAD	
C605	1-164-937-11	CERAMIC CHIP	0.001uF 10% 50V	FB802	1-500-282-11	INDUCTOR, FERRITE BEAD	
C606	1-164-874-11	CERAMIC CHIP	100PF 5% 50V			< IC >	
C607	1-125-777-11	CERAMIC CHIP	0.1uF 10% 10V	IC301	6-703-859-01	IC AK4566VN-L	
C608	1-125-777-11	CERAMIC CHIP	0.1uF 10% 10V	IC303	6-702-990-01	IC LLM4903MMX/J5000273	
C701	1-125-777-11	CERAMIC CHIP	0.1uF 10% 10V	IC501	6-705-496-01	IC XC9206A163MR	
C702	1-125-777-11	CERAMIC CHIP	0.1uF 10% 10V	IC502	6-701-734-01	IC XC9105D091MR	
C703	1-125-777-11	CERAMIC CHIP	0.1uF 10% 10V	IC503	6-705-321-01	IC S1F77600MOA000L	
C704	1-125-777-11	CERAMIC CHIP	0.1uF 10% 10V	IC504	6-703-865-01	IC XC61CS23XXNR	
C705	1-125-777-11	CERAMIC CHIP	0.1uF 10% 10V	IC505	6-703-074-01	IC XC6204B252MR	
C707	1-125-777-11	CERAMIC CHIP	0.1uF 10% 10V	IC506	6-705-498-01	IC R1160N311B-TR-FA	
C708	1-164-937-11	CERAMIC CHIP	0.001uF 10% 50V	IC508	6-705-495-01	IC R1180Q241B-TR-FA	
C710	1-164-941-11	CERAMIC CHIP	0.0047uF 10% 50V	IC509	6-705-499-01	IC XC6219C312MR	
C711	1-164-941-11	CERAMIC CHIP	0.0047uF 10% 16V	IC513	6-703-864-01	IC R1160N291B-TR-FA	
C712	1-164-941-11	CERAMIC CHIP	0.0047uF 10% 16V	@ IC601	6-803-583-01	IC uPD77213F1-101-DA2	
C715	1-164-874-11	CERAMIC CHIP	100PF 5% 50V	IC602	6-703-867-01	IC NJU6366AF1(TE1)	
C716	1-125-777-11	CERAMIC CHIP	0.1uF 10% 10V	IC701	6-705-497-01	IC LC67F5006A-F3A15-E	
C717	1-164-937-11	CERAMIC CHIP	0.001uF 10% 50V	@ IC702	6-701-667-01	IC uPD442002F9-BB70X-BC2-A	
C718	1-125-777-11	CERAMIC CHIP	0.1uF 10% 10V	IC703	6-703-861-01	IC RX-4591CF	
C719	1-125-777-11	CERAMIC CHIP	0.1uF 10% 10V	IC704	8-759-670-89	IC BU2090FS-E2	
C720	1-110-569-11	TANTAL. CHIP	47uF 20% 6.3V	* IC705	6-702-923-01	IC AK6417CH-E2	
C721	1-125-777-11	CERAMIC CHIP	0.1uF 10% 10V	IC706	8-759-698-31	IC TC7WH74FK	
C722	1-125-777-11	CERAMIC CHIP	0.1uF 10% 10V	IC707	6-701-736-01	IC R3130N28EA-TR	
C727	1-125-777-11	CERAMIC CHIP	0.1uF 10% 10V	IC801	6-702-098-01	IC M66291GP-2	
C728	1-125-777-11	CERAMIC CHIP	0.1uF 10% 10V				
C729	1-125-777-11	CERAMIC CHIP	0.1uF 10% 10V				
C733	1-125-777-11	CERAMIC CHIP	0.1uF 10% 10V				
C735	1-125-777-11	CERAMIC CHIP	0.1uF 10% 10V				
C737	1-125-777-11	CERAMIC CHIP	0.1uF 10% 10V				
C738	1-125-777-11	CERAMIC CHIP	0.1uF 10% 10V				

@ Replacement of uPD77213F1-101-DA2 (IC601) and uPD442002F9-BB70X-BC2-A (IC702) used in this set requires a special tool. Therefore, it cannot be replaced.

Ref. No.	Part No.	Description	Remark	Ref. No.	Part No.	Description	Remark
		< JACK >		R503	1-218-989-11	RES-CHIP 1M 5%	1/16W
J301	1-818-055-11	JACK (⊖)		R504	1-218-989-11	RES-CHIP 1M 5%	1/16W
J302	1-818-056-11	JACK (⊕) (PLUG IN POWER)		R505	1-208-943-11	METAL CHIP 220K 0.5%	1/16W
J501	1-794-615-11	JACK, DC (POLARITY UNIFIED TYPE)	(DC IN 3V)	R506	1-218-989-11	METAL CHIP 1M 0.5%	1/16W
		< JUMPER RESISTOR >		R507	1-218-989-11	METAL CHIP 1M 0.5%	1/16W
JC701	1-218-990-11	SHORT CHIP 0		R508	1-218-989-11	METAL CHIP 1M 0.5%	1/16W
		< COIL >		R509	1-220-804-11	RES-CHIP 2.2M 5%	1/16W
L501	1-456-679-21	COIL, CHOKE		R510	1-218-985-11	RES-CHIP 470K 5%	1/16W
L502	1-456-679-21	COIL, CHOKE		R512	1-218-985-11	RES-CHIP 470K 5%	1/16W
LF301	1-428-965-11	COIL, CHOKE (SMD)		R513	1-218-985-11	RES-CHIP 470K 5%	1/16W
		< TRANSISTOR >		R514	1-216-809-11	METAL CHIP 100 5%	1/10W
Q301	6-551-064-01	FET TPCF8201(T5RSONY.F)		R515	1-216-809-11	METAL CHIP 100 5%	1/10W
Q501	8-729-053-03	FET XP151A12A2MR		R516	1-218-977-11	RES-CHIP 100K 5%	1/16W
Q502	6-550-746-01	FET 3LN01S-K-TL-E		R517	1-218-985-11	RES-CHIP 470K 5%	1/16W
Q503	6-550-746-01	FET 3LN01S-K-TL-E		R521	1-218-985-11	RES-CHIP 470K 5%	1/16W
Q504	6-550-861-01	FET NTHS2101PT1G		R523	1-218-945-11	RES-CHIP 220 5%	1/16W
Q505	6-551-064-01	FET TPCF8201(T5RSONY.F)		R604	1-218-985-11	RES-CHIP 470K 5%	1/16W
Q506	6-550-747-01	FET 3LP01S-K-TL-E		R605	1-218-985-11	RES-CHIP 470K 5%	1/16W
Q507	6-550-746-01	FET 3LN01S-K-TL-E		R613	1-218-985-11	RES-CHIP 470K 5%	1/16W
Q509	8-729-041-23	FET NDS356AP		R614	1-218-937-11	RES-CHIP 47 5%	1/16W
Q511	6-550-746-01	FET 3LN01S-K-TL-E		R621	1-218-990-11	SHORT CHIP 0	
Q701	6-550-748-01	FET MCH6610-K-TL-E		R622	1-218-937-11	RES-CHIP 47 5%	1/16W
Q702	8-729-402-32	TRANSISTOR 2SD1819A-R		R701	1-218-977-11	RES-CHIP 100K 5%	1/16W
Q703	6-550-747-01	FET 3LP01S-K-TL-E		R702	1-218-985-11	RES-CHIP 470K 5%	1/16W
Q704	6-550-747-01	FET 3LP01S-K-TL-E		R703	1-218-977-11	RES-CHIP 100K 5%	1/16W
		< RESISTOR >		R704	1-218-985-11	RES-CHIP 470K 5%	1/16W
R101	1-218-961-11	RES-CHIP 4.7K 5%	1/16W	R705	1-218-985-11	RES-CHIP 470K 5%	1/16W
R102	1-218-941-81	RES-CHIP 100 5%	1/16W	R707	1-481-021-21	INDUCTOR, FERRITE BEAD	
R108	1-220-803-81	RES-CHIP 4.7 5%	1/16W	R708	1-481-021-21	INDUCTOR, FERRITE BEAD	
R109	1-218-953-11	RES-CHIP 1K 5%	1/16W	R714	1-218-985-11	RES-CHIP 470K 5%	1/16W
R110	1-218-953-11	RES-CHIP 1K 5%	1/16W	R715	1-218-977-11	RES-CHIP 100K 5%	1/16W
R201	1-218-961-11	RES-CHIP 4.7K 5%	1/16W	R716	1-218-977-11	RES-CHIP 100K 5%	1/16W
R202	1-218-941-81	RES-CHIP 100 5%	1/16W	R717	1-218-965-11	RES-CHIP 10K 5%	1/16W
R208	1-220-803-81	RES-CHIP 4.7 5%	1/16W	R718	1-218-965-11	RES-CHIP 10K 5%	1/16W
R209	1-218-953-11	RES-CHIP 1K 5%	1/16W	R719	1-218-990-11	SHORT CHIP 0	
R210	1-218-953-11	RES-CHIP 1K 5%	1/16W	R720	1-218-953-11	RES-CHIP 1K 5%	1/16W
R301	1-218-977-11	RES-CHIP 100K 5%	1/16W	R721	1-218-985-11	RES-CHIP 470K 5%	1/16W
R302	1-218-981-11	RES-CHIP 220K 5%	1/16W	R722	1-208-927-11	METAL CHIP 47K 0.5%	1/16W
R304	1-218-990-11	SHORT CHIP 0		R723	1-208-927-11	METAL CHIP 47K 0.5%	1/16W
R306	1-218-990-11	SHORT CHIP 0		R724	1-218-985-11	RES-CHIP 470K 5%	1/16W
R308	1-218-981-11	RES-CHIP 220K 5%	1/16W	R725	1-218-985-11	RES-CHIP 470K 5%	1/16W
R309	1-218-977-11	RES-CHIP 100K 5%	1/16W	R726	1-218-965-11	RES-CHIP 10K 5%	1/16W
R311	1-218-969-11	RES-CHIP 22K 5%	1/16W	R729	1-218-985-11	RES-CHIP 470K 5%	1/16W
R316	1-218-990-11	SHORT CHIP 0		R730	1-218-985-11	RES-CHIP 470K 5%	1/16W
R317	1-218-985-11	RES-CHIP 470K 5%	1/16W	R732	1-218-985-11	RES-CHIP 470K 5%	1/16W
R318	1-218-977-11	RES-CHIP 100K 5%	1/16W	R733	1-218-965-11	RES-CHIP 10K 5%	1/16W
R319	1-218-985-11	RES-CHIP 470K 5%	1/16W	R734	1-218-977-11	RES-CHIP 100K 5%	1/16W
R321	1-218-945-11	RES-CHIP 220 5%	1/16W	R735	1-218-977-11	RES-CHIP 100K 5%	1/16W
R322	1-218-977-11	RES-CHIP 100K 5%	1/16W	R750	1-218-985-11	RES-CHIP 470K 5%	1/16W
R323	1-218-929-11	RES-CHIP 10 5%	1/16W	R753	1-218-949-11	RES-CHIP 470 5%	1/16W
R501	1-218-985-11	RES-CHIP 470K 5%	1/16W	R755	1-218-985-11	RES-CHIP 470K 5%	1/16W
R502	1-218-985-11	RES-CHIP 470K 5%	1/16W	R756	1-218-985-11	RES-CHIP 470K 5%	1/16W
				R758	1-218-949-11	RES-CHIP 470 5%	1/16W
				R760	1-218-965-11	RES-CHIP 10K 5%	1/16W
				R804	1-218-933-11	RES-CHIP 22 5%	1/16W
				R807	1-218-933-11	RES-CHIP 22 5%	1/16W
				R808	1-218-989-11	RES-CHIP 1M 5%	1/16W
				R810	1-218-977-11	RES-CHIP 100K 5%	1/16W

ICD-BM1VTP

MAIN **SW**

Ref. No.	Part No.	Description	Remark
R812	1-218-985-11	RES-CHIP 470K 5%	1/16W
R813	1-218-985-11	RES-CHIP 470K 5%	1/16W
R814	1-218-985-11	RES-CHIP 470K 5%	1/16W
R816	1-218-957-11	RES-CHIP 2.2K 5%	1/16W
R817	1-218-961-11	RES-CHIP 4.7K 5%	1/16W
R818	1-218-945-11	RES-CHIP 220 5%	1/16W
R819	1-218-949-11	RES-CHIP 470 5%	1/16W
< NETWORK RESISTOR >			
RB601	1-233-973-11	RES, NETWORK (CHIP TYPE) 100KX4	
RB602	1-233-973-11	RES, NETWORK (CHIP TYPE) 100KX4	
RB603	1-233-977-11	RES, NETWORK (CHIP TYPE) 470KX4	
RB604	1-233-973-11	RES, NETWORK (CHIP TYPE) 100KX4	
RB605	1-233-973-11	RES, NETWORK (CHIP TYPE) 100KX4	
RB606	1-233-973-11	RES, NETWORK (CHIP TYPE) 100KX4	
RB701	1-233-977-11	RES, NETWORK (CHIP TYPE) 470KX4	
< FILTER >			
T501	1-416-405-21	FILTER, CHIP EMI (COMMON MODE)	
< THERMISTOR (POSITIVE) >			
TH501	1-805-202-11	THERMISTOR, POSITIVE	
< VARISTOR >			
VDR301	1-804-499-21	VARISTOR, CHIP (1608)	
< VIBRATOR >			
X601	1-813-165-21	VIBRATOR, CRYSTAL (11.2896MHz)	
X701	1-813-166-21	VIBRATOR, CERAMIC (15MHz)	
X801	1-813-164-21	VIBRATOR, CRYSTAL (12MHz)	

*	A-4541-673-A	SW BOARD, COMPLETE	

< CAPACITOR >			
C951	1-164-937-11	CERAMIC CHIP 0.001uF 10%	50V
C952	1-164-941-11	CERAMIC CHIP 0.0047uF 10%	16V
C953	1-164-941-11	CERAMIC CHIP 0.0047uF 10%	16V
C954	1-100-770-11	CAP, SQUARE TYPE CHIP CERAMIC	0.01uFX4
< CONNECTOR >			
CN951	1-794-747-21	CONNECTOR, FFC (LIF(NON-ZIF)) 14P	
< DIODE >			
D951	6-500-774-01	LED CL-165TR1/SYG-D-T (OPR)	
D952	6-500-115-01	DIODE RB731XN	
< TRANSISTOR >			
Q951	8-729-402-32	TRANSISTOR 2SD1819A-R	
Q952	8-729-429-44	TRANSISTOR XP1501	
< RESISTOR >			
R951	1-218-953-11	RES-CHIP 1K 5%	1/16W
R952	1-218-953-11	RES-CHIP 1K 5%	1/16W
R953	1-218-953-11	RES-CHIP 1K 5%	1/16W
R956	1-218-981-11	RES-CHIP 220K 5%	1/16W

Ref. No.	Part No.	Description	Remark
R957	1-218-961-11	RES-CHIP 4.7K 5%	1/16W
R958	1-218-953-11	RES-CHIP 1K 5%	1/16W
R959	1-218-977-11	RES-CHIP 100K 5%	1/16W
R962	1-218-953-11	RES-CHIP 1K 5%	1/16W
R963	1-218-953-11	RES-CHIP 1K 5%	1/16W
R964	1-218-977-11	RES-CHIP 100K 5%	1/16W
R965	1-218-981-11	RES-CHIP 220K 5%	1/16W
R966	1-218-957-11	RES-CHIP 2.2K 5%	1/16W
R968	1-218-989-11	RES-CHIP 1M 5%	1/16W
R969	1-218-957-11	RES-CHIP 2.2K 5%	1/16W
R970	1-218-961-11	RES-CHIP 4.7K 5%	1/16W
R972	1-218-965-11	RES-CHIP 10K 5%	1/16W
R973	1-218-985-11	RES-CHIP 470K 5%	1/16W
R974	1-218-985-11	RES-CHIP 470K 5%	1/16W
< NETWORK RESISTOR >			
RB951	1-233-977-11	RES, NETWORK (CHIP TYPE) 470KX4	
< SWITCH >			
S951	1-771-246-21	SWITCH, SLIDE (DPC)	
S952	1-572-922-11	SWITCH, SLIDE (MIC)	
S953	1-572-922-11	SWITCH, SLIDE (VOR)	
S954	1-771-844-21	SWITCH, TACTILE (SMD) (VOL -)	
S955	1-771-246-21	SWITCH, SLIDE (POWER)	
S956	1-786-644-21	SWITCH, PUSH (1 KEY) (FUNCTION-A)	
S957	1-771-844-21	SWITCH, TACTILE (SMD) (VOL +)	
S958	1-786-179-31	SWITCH, PUSH (1 KEY) (FUNCTION-B)	
S959	1-786-652-11	SWITCH, TACTILE (- I◀▶)	
S960	1-786-652-11	SWITCH, TACTILE (▶▶ +)	
S961	1-786-643-21	SWITCH, PUSH (1 KEY) (OPEN/CLOSE)	
S962	1-786-638-21	SWITCH, TACTILE (NEW FILE)	

MISCELLANEOUS			

153	1-860-925-11	FLEXIBLE BOARD	
211	1-818-067-11	CONNECTOR, MEMORY STICK	
EL901	1-805-472-11	ELEMENT, EL	
LCD901	1-477-070-11	INDICATOR UNIT, LIQUID CRYSTAL	
MIC301	1-542-572-11	MICROPHONE, ELECTRET CAP (Mic)	
SP301	1-825-645-11	SPEAKER (2.8cm)	

ACCESSORIES			

*	1-543-798-11	FILTER, CLAMP (FERRITE CORE)	
	1-823-519-31	CORD, CONNECTION (USB)	
	2-585-846-11	SOFT (CD-ROM), APPLICATION (DRAGON)	
	2-585-847-11	INSTRUCTION (DRAGON) (ENGLISH)	
	3-258-652-13	MANUAL (DVE2.2), INSTRUCTION (ENGLISH)	
	3-258-853-13	MANUAL, INSTRUCTION, MAIN (ENGLISH)	
	3-260-513-01	CASE, CARRYING	
	3-260-920-14	SOFT (CD-ROM), APPLICATION (Digital Voice Editor)	
	3-261-558-11	CARD, QUICK REFERENCE	
	8-954-008-92	RECEIVER, EAR MDR-E808LP	

MEMO

