

PS-5550

*USA Model
Canada Model
AEP Model
UK Model*



STEREO TURNTABLE SYSTEM

SPECIFICATIONS

GENERAL

Speeds:	33 $\frac{1}{3}$, 45 rpm
Speed control range:	$\pm 4\%$
Turntable drive system:	belt-drive
Wow and flutter:	Less than 0.06 % wrms (NAB) Less than $\pm 0.08\%$ (DIN45539)
Signal-to-noise ratio:	Greater than 65 dB, weighted (DIN 45539)
Motor:	DC servo-controlled motor
Turntable platter:	300 mm (12") dia, 1 kg (2 lb 3 oz) diecasted aluminum
Power consumption:	6 watts (USA and Canada Model) 10 watts (AEP and UK Model)
Power requirements:	120 V, 60 Hz (USA and Canada Model) 110, 127, 220 and 240 V (AEP and UK Model), 50/60 Hz ac
Dimensions:	470 (w) x 136 (h) x 383 (d) mm 18 $\frac{1}{2}$ (w) x 5 $\frac{3}{8}$ (h) x 15 $\frac{1}{8}$ (d) inches
Net weight:	9 kg (20 lb) (USA and Canada Model) 9.3 kg (20 lb 8 oz) (AEP and UK Model)
Shipping weight:	10.5 kg (23 lb) (USA and Canada Model) 10.8 kg (23 lb 13 oz) (AEP and UK Model)

TONEARM (PUA-310)

Type:	Static balanced
Arm length:	334 mm (13 $\frac{1}{8}$ "), overall 237 mm (9 $\frac{3}{8}$ "), pivot-to-stylus
Overhang:	15 mm ($\frac{9}{16}$ ")
Cartridge offset angle:	21° 30'
Tracking error:	+2° 30', -1° 20'
Stylus-force adjustment range:	0 to 3 g
Anti-skating force compensation range:	0 to 3 g, 0.5 g increments
Cartridge weight range:	4 to 14 g 13 to 21.5 g (with extra weight)
Shell-head weight:	10.5 g

SONY[®]
SERVICE MANUAL

TABLE OF CONTENTS

<u>Section</u>	<u>Title</u>	<u>Page</u>
1.	TECHNICAL DESCRIPTION	3
	1-1. Principles of Operation	3
	1-2. Block Diagram	7
2.	DISASSEMBLY AND REPLACEMENT	8
	2-1. Top Cover Removal	8
	2-2. Turntable Platter Removal	8
	2-3. Turntable Base Removal	8
	2-4. Tonearm Replacement	8
	2-5. Main Cam Replacement	9
	2-6. Drive Motor Replacement	9
	2-7. Motor Pulley Replacement	10
	2-8. Turntable Shaft Replacement	10
	2-9. Turntable Thrust Bearing Replacement	10
	2-10. CDS Replacement	11
	2-11. Lamp Replacement	11
	2-12. Auto-Return Trigger Motor Replacement	11
	2-13. Release Link Replacement	11
3.	ADJUSTMENTS	13
	3-1. Tonearm Height Adjustment	13
	3-2. Turntable Speed Adjustment	13
	3-3. Automatic Return Adjustment	14
	3-4. Microswitch Adjustment	15
4.	REPACKING	17
5.	DIAGRAMS	19
	5-1. Mounting/Wiring Diagram	19
	5-2. Schematic Diagram	21
6.	EXPLODED VIEWS	23
7.	ELECTRICAL PARTS LIST	28

Applicable Serial Numbers:

USA Model 802,001 and later
 Canada Model 50,001 and later
 AEP Model 500,001 and later
 UK Model 600,001 and later

SECTION 1

TECHNICAL DESCRIPTION

1-1. PRINCIPLES OF OPERATION

The principles of operation are useful, particularly when the cause of troubles is not obvious. To follow the action of the mechanism, disconnect the power supply and rotate the turntable by hand.

Automatic Operation Cycle

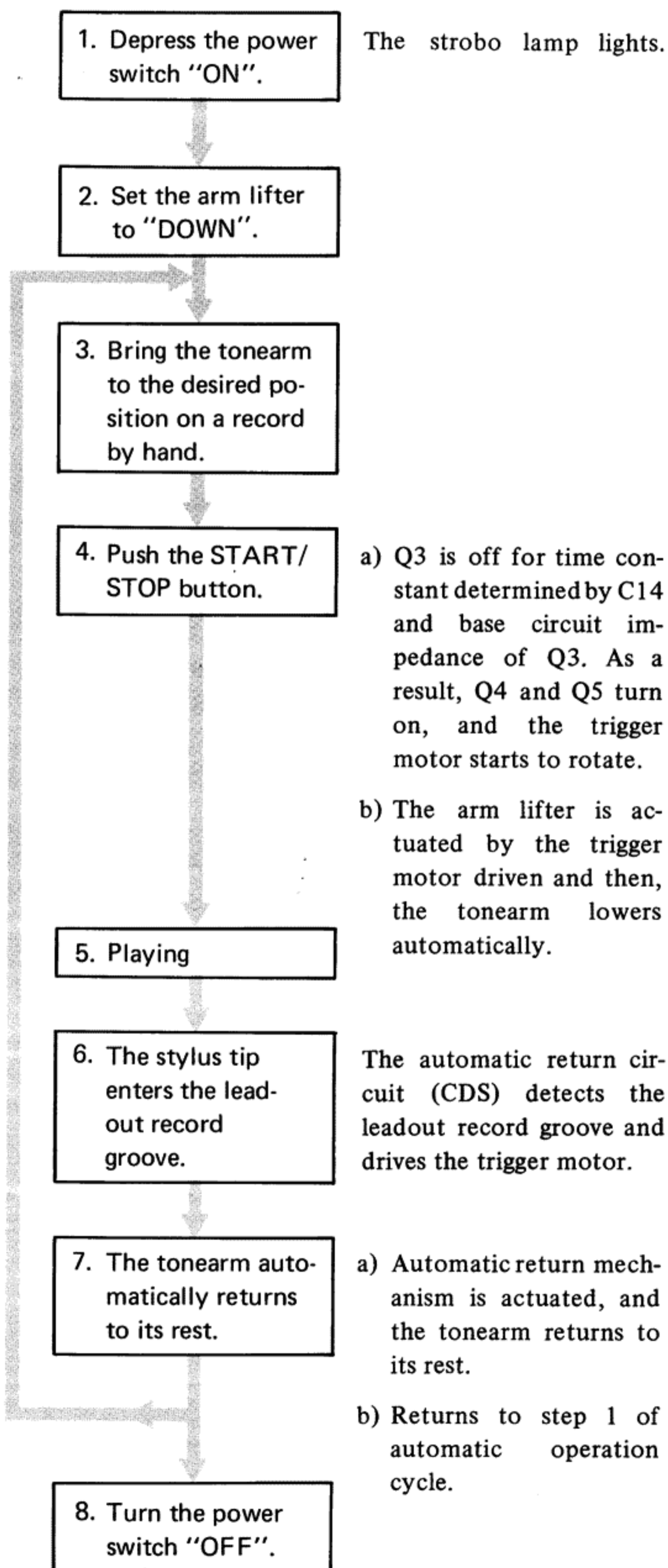

AC Servo System

Fig. 1-1 shows a simplified diagram of the dc servo system employed in this set. Since the motor speed is proportional to the applied voltage, it is controlled by varying the applied voltage (EM) to the motor. This is effectively performed by means of series resistor Rv.

In practice, series resistor Rv is replaced by the collector-emitter impedance of transistor as illustrated in Fig. 1-2.

Motor speed is converted into ac signal by means of a direct-coupled frequency generator. The servo amplifier compares this signal against a very stable dc reference voltage, and then controls the collector-emitter impedance of transistor. Any error in motor speed results in a correction voltage supplied to the motor.

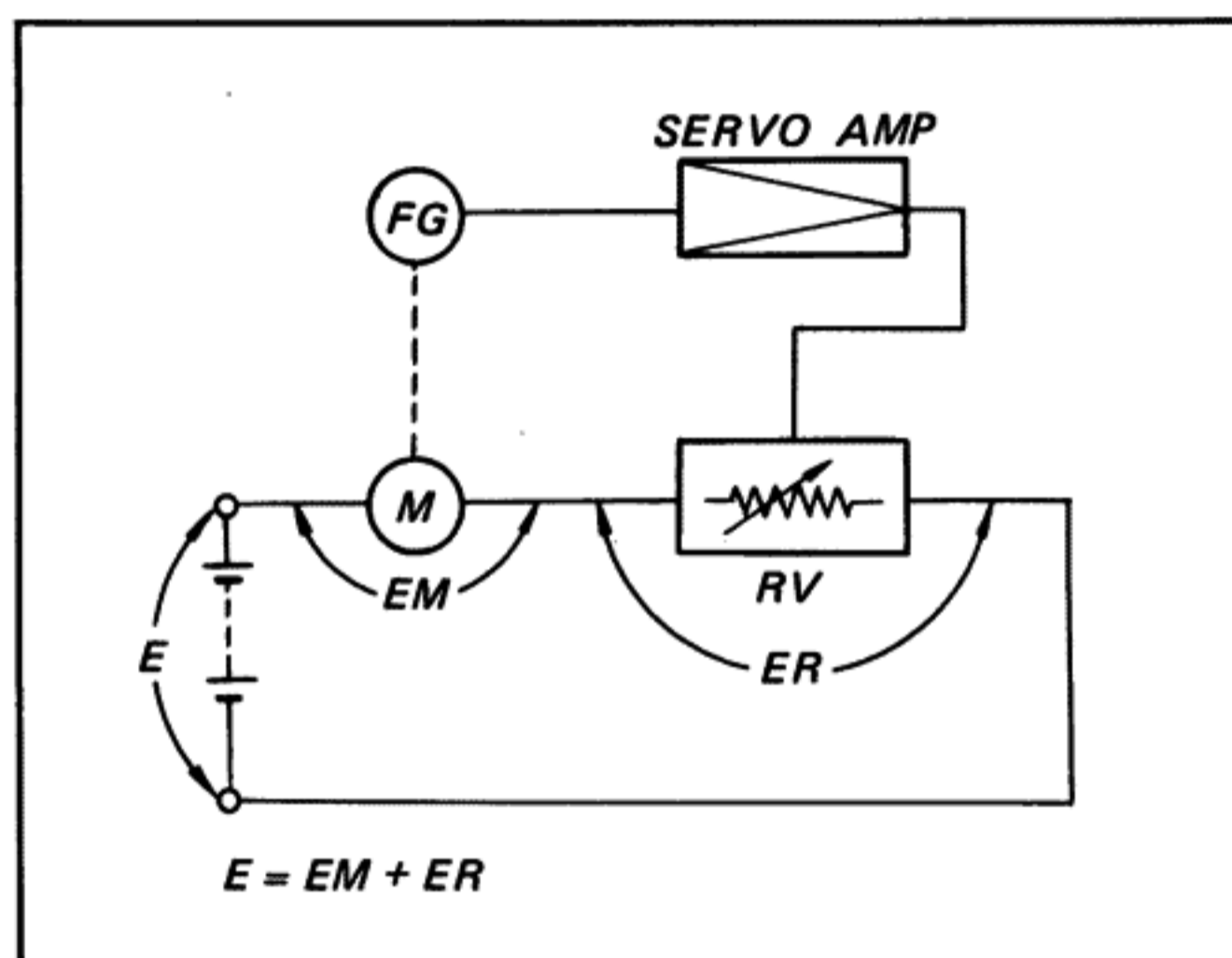

Fig. 1-1. Principle of dc servo system

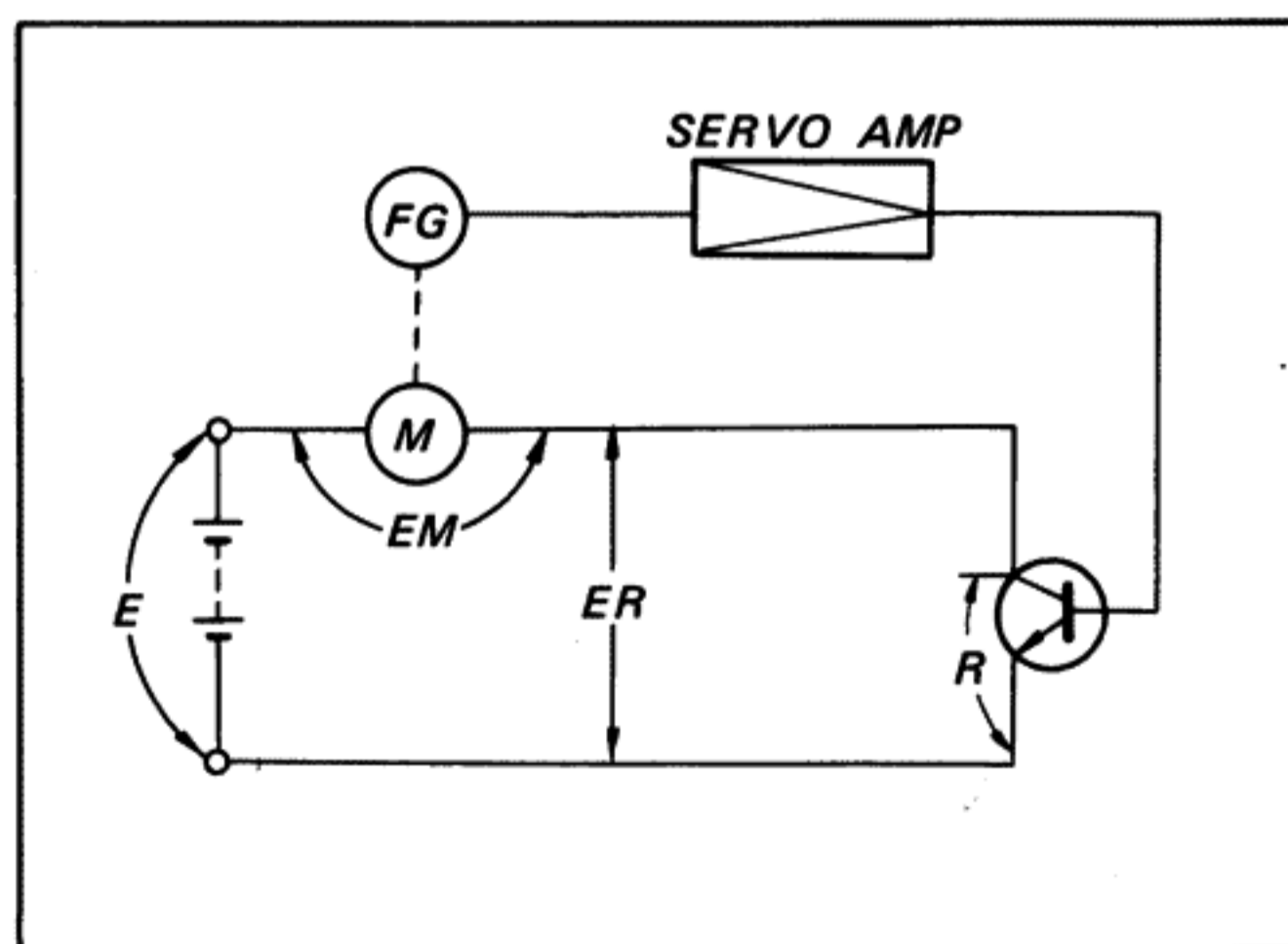

Fig. 1-2. Practical servo system

Stage/ControlFunction

Frequency generator

When the motor starts to revolve, the frequency generator (F.G.) generates ac voltage whose frequency is proportional to the motor speed. As the frequency generator is directly coupled to the shaft of the drive motor, it converts motor speed into frequency.

Flip-flop circuit

Flip-flop circuit generates square output in accordance with the input trigger signal.

Differential circuit C1, R01

Square wave output from the flip-flop circuit is converted into spike pulses through the differential circuit (formed by C1 and R01) to trigger the following saw-tooth wave generator (Q01).

Saw-tooth wave generator
Q01, C3, R1, R2, R29, R30, R33, R34

Q01 and RC components (C3, R1, R2, R29, R30, R33, R34) in the collector circuit form a saw-tooth wave generator. Note that the frequency of the saw-tooth wave is determined by the RC time constant in the collector circuit.

Voltage comparator The output is extracted from the collector of Q01 only when the collector voltage of Q01 (terminal No. 3 of IC) becomes higher than the reference voltage

Stage/ControlFunction

of terminal No. 4 of IC.

The constant voltage is supplied to the terminal No. 4 of IC as the reference voltage through R3, R4 and Th1.

Filter circuit

The RC network consisting of R6, R7 and C6 converts the input positive pulses into a dc voltage proportional to the input pulse width.

Impedance converter

This circuit acts as the buffer between Q6 and the phase inverter circuit.

8: B+ voltage

9: input terminal

10: output terminal

Note: # shows IC terminal.

Phase inverter circuit

The network consisting of C7, C8, R8 and R9 is employed to provide stability of action in the servo system.

Voltage regulator

The voltage regulator supplies a stabilizing B+ voltage to the IC circuit in spite of fluctuation of the ac power supply voltage or load.

7: B+ input terminal

5: stabilizing B+ output voltage

6: reference voltage terminal

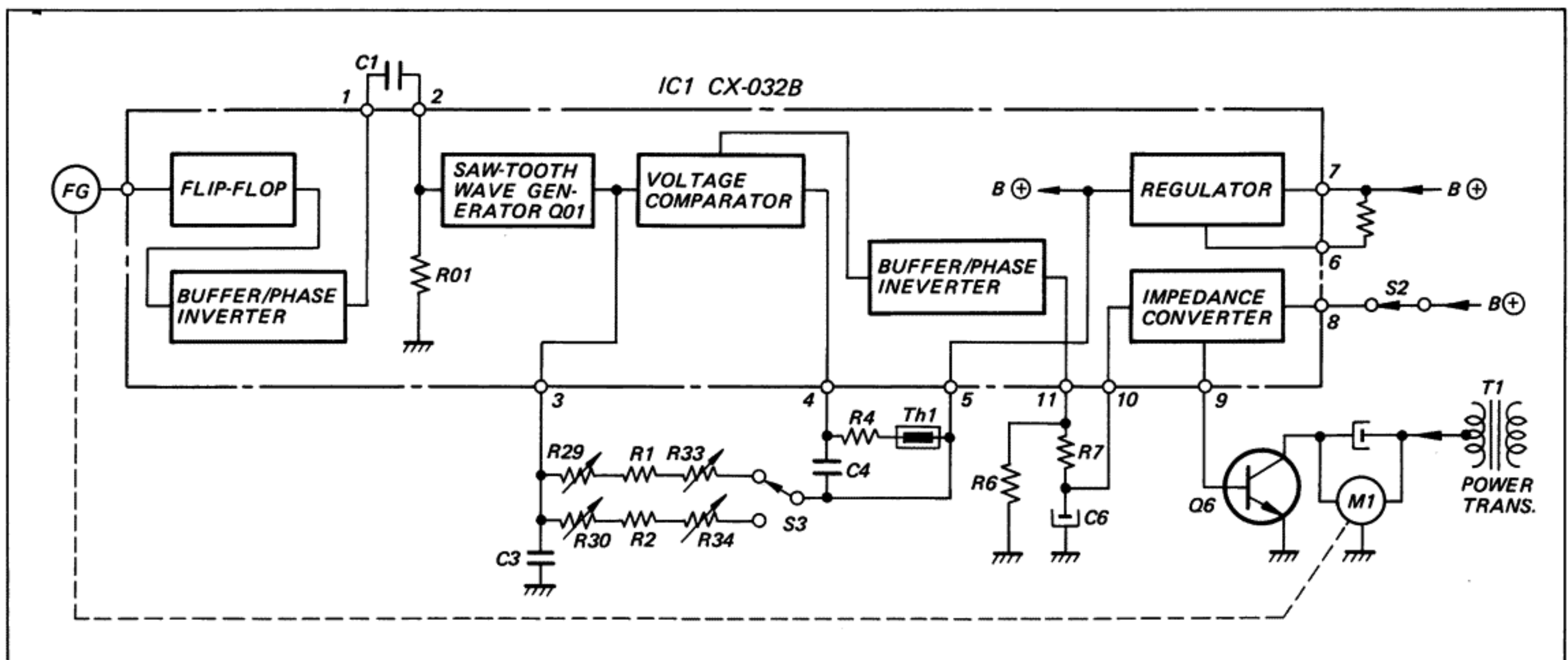

Fig. 1-3. IC Block diagram

Stage/Control

Function

Servo Operation

When, by any cause, the motor speed becomes slightly faster or slower than the specified value, the servo system works as follows:

Referring to Fig. 1-4, assume that the motor speed becomes faster. The FG output signal frequency becomes higher, resulting in a shorter interval between pulses for triggering the saw-tooth wave generator. The shorter interval between trigger pulses causes lower saw-tooth wave height, which in turn yields a shorter "ON" period for comparator. Therefore, the output pulse width at # 11 becomes shorter, reducing the positive bias upon Q6. As a result, the collector-emitter impedance of Q6 increases, reducing the motor speed.

Conversely, if the motor speed becomes slower, the collector-emitter impedance of Q6 decreases, increasing the motor speed.

Speed selector switch S3

Speed changeover operation is performed by changing the saw-tooth wave frequency as previously described. Since the saw-tooth wave frequency is

Stage/Control

Function

determined by the RC time constant in the collector circuit of Q01, the speed selection is performed by changing the RC time constant of R1, R29, R33 (33 rpm) and R2, R30, R34 (45 rpm). A smaller time constant results in faster motor speed and vice versa.

Automatic return circuit

The PS-5550 employs an automatic return mechanism which detects the rotation angle of the tonearm electrically by using CDS. The main ingredient of CDS is cadmium sulfide and CDS is the element that the resistance is changeable by brightness applied on CDS. As it brightening, its resistance decreases.

CDS faces each other with a lamp and the shutter joining to the tonearm is inserted between them.

When the tonearm moves towards the center of the record, dependent on the pitch of the record groove, the resistance value of CDS decreases. As the pitch of the lead-out groove is greater than that of the lead-in groove, rotation angle of the tonearm in the lead-out groove is larger.

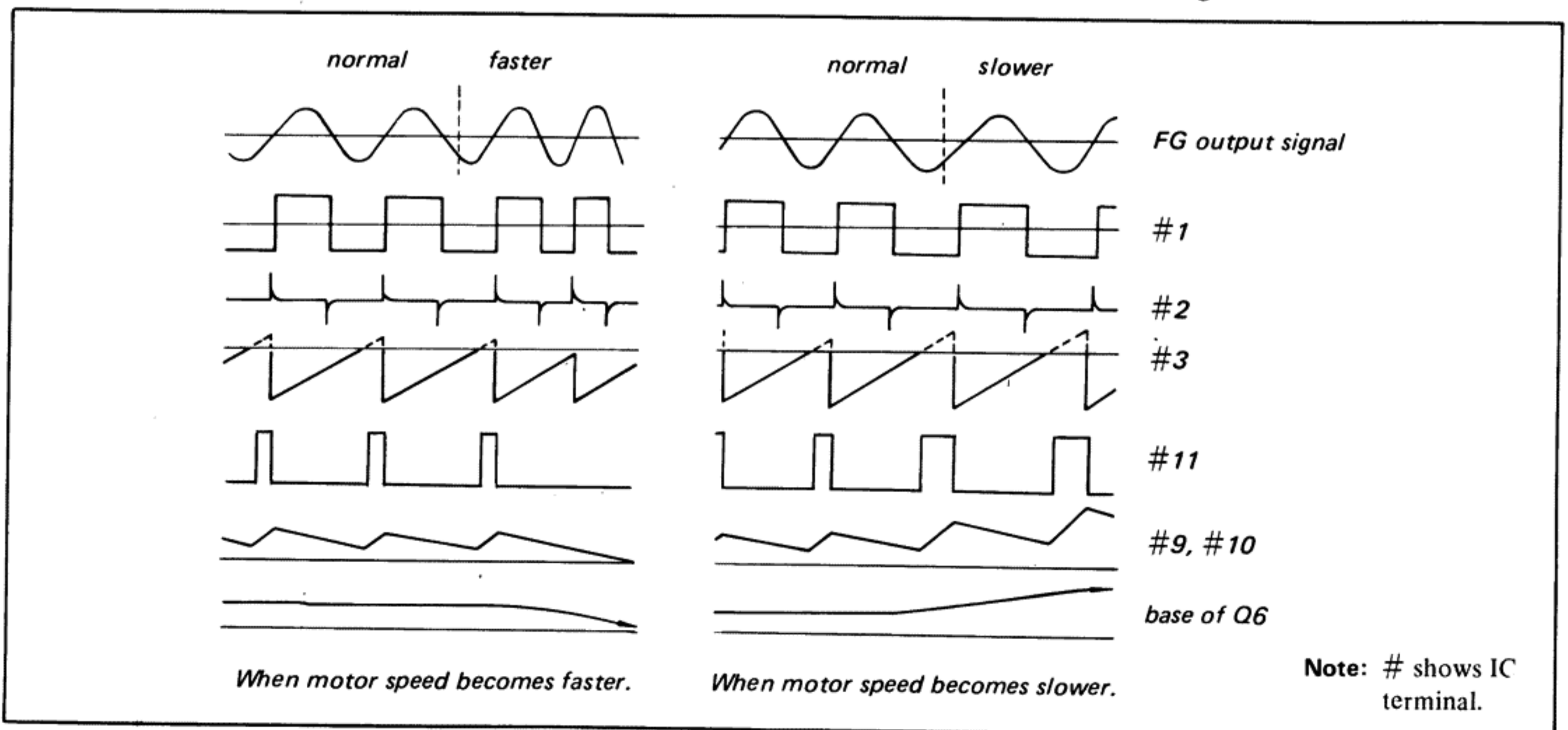

Fig. 1-4. Waveforms on servo control circuit

Stage/Control

Function

Stage/Control

Function

Therefore, the decreasing speed of the resistance of CDS becomes faster and detection of automatic return in the lead-out groove becomes possible. The higher collector voltage of Q2 caused by the pitch of the lead-out groove operates the trigger motor (M2) which actuates the automatic return mechanism.

Schmitt trigger circuit Q3, Q4

When the input voltage becomes lower (higher) than a specified value, Q3 is turned off (on) and Q4 is turned on (off) rapidly, because of the positive feedback works from the emitter of Q4 to the emitter of Q3. The reference voltage is decided to make Q3 on and Q4 off by R32 (trigger level adjustment) during playing. When the stylus enters the lead-out record groove, the negative voltage of C15 is supplied to the base of Q3 and it makes Q3 off, Q4 on, and Q5 on. As a result, the trigger motor rotates and the tonearm starts to return automatically.

Lamp drive circuit Q1

The brightness of the lamp is changeable by R31 (lamp brightness adjustment). When the shutter is fully open, the detection sensitivity of CDS is determined by adjusting the dc resistance of CDS to the specified value by R31.

C10

The trigger motor rotates by the voltage charged in C10.

Detection circuit Q2

Q2 converts the change of dc resistance of CDS into that of dc voltage. The collector voltage of Q2 decreases gradually according to inward movement of tonearm.

Mis-operation proof circuit Q7

Q7 prevents the mis-operation of Schmitt trigger circuit when the power switch turns off. Q7 is kept on only for the time constant by R39, R40 and C16 after the POWER switch is off.

Differential capacitor C15

C15 detects the voltage in proportion to the speed that the tonearm moves inward. As the collector voltage of Q2 decreases, the negative output voltage of C15 appears.

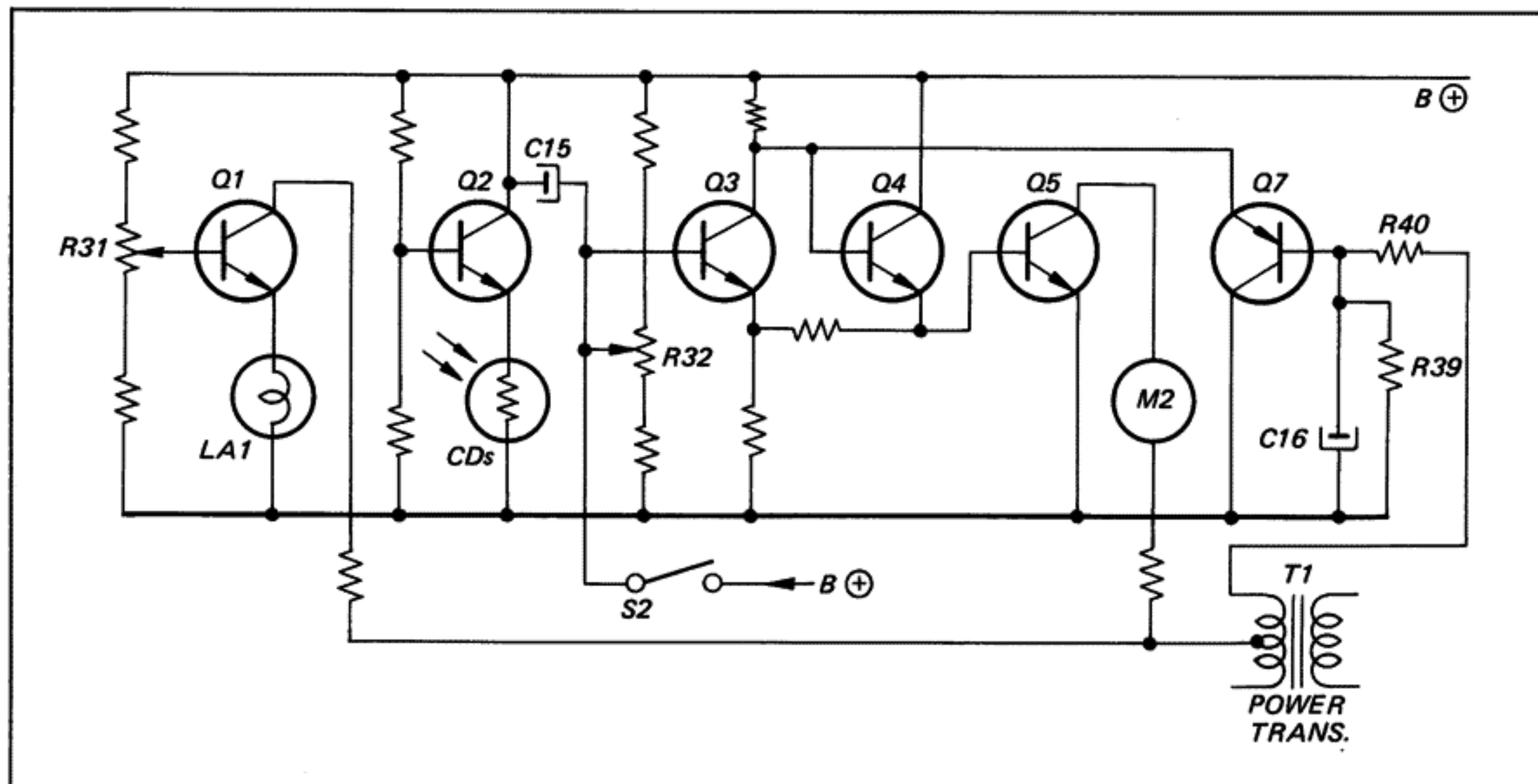
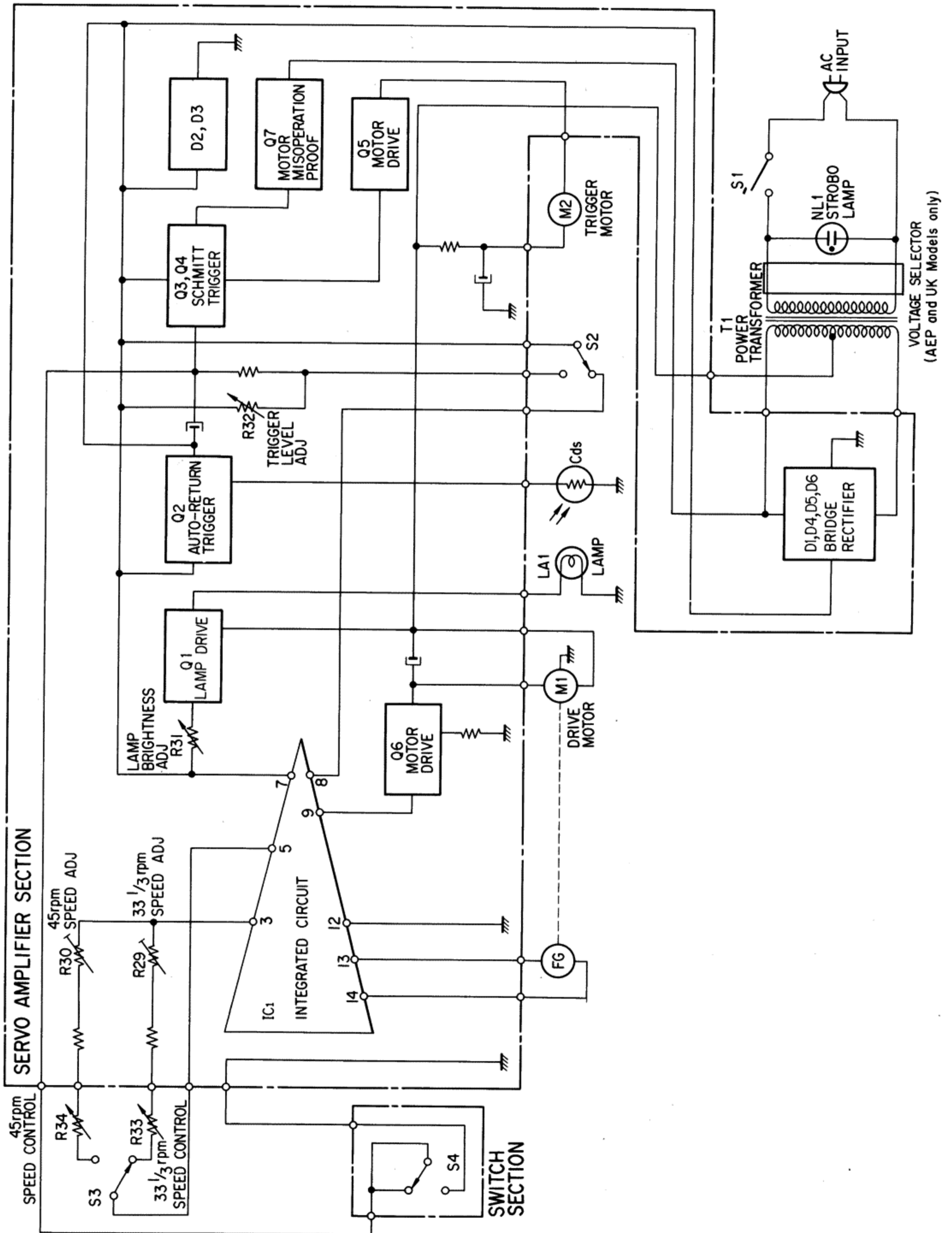

Fig. 1-5. Automatic return circuit

1-2. BLOCK DIAGRAM



SECTION 2

DISASSEMBLY AND REPLACEMENT

WARNING

Unplug the ac power cord before starting any disassembly or replacement procedures.

CAUTION

To avoid damage to the stylus while performing the following procedures, make sure that the stylus protecting cover is in place.

Note: All screws are Phillips type (cross recess type) unless otherwise indicated.
(-): slotted head

2-1. TOP COVER REMOVAL

1. Open the top cover and lift the top cover straight up as shown in Fig. 2-1.

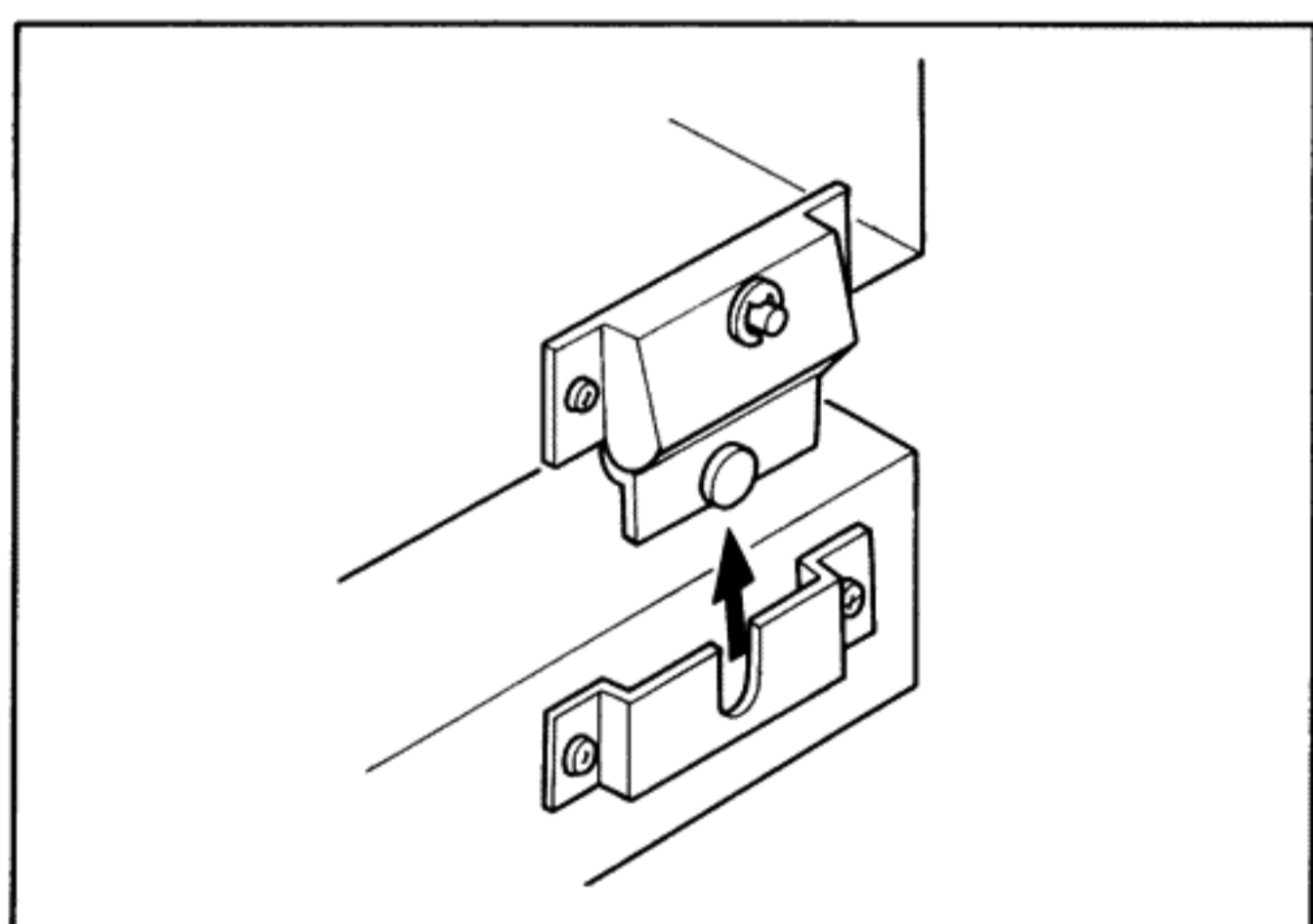

Fig. 2-1. Top cover removal

2-2. TURNTABLE PLATTER REMOVAL

1. Remove the top cover as described in Procedure 2-1.
2. Remove the rubber mat from the turntable platter and unhook the drive belt from the motor pulley.
3. Insert your both thumbs into the two holes of the turntable platter as shown in Fig. 2-2.
4. Carefully lift the turntable platter straight up.

2-3. TURNTABLE BASE REMOVAL

1. Remove the turntable platter as described in Procedure 2-2.
2. Remove the nut ①, spacer ② and washer ③ securing the turntable base to the wooden case as shown in Fig. 2-2.
3. Lift the turntable base carefully and remove the release link ④ shown in Fig. 2-2.
4. Disconnect the four connectors ⑤, ⑥, ⑦, ⑧ shown in Fig. 2-2. This frees the turntable base.

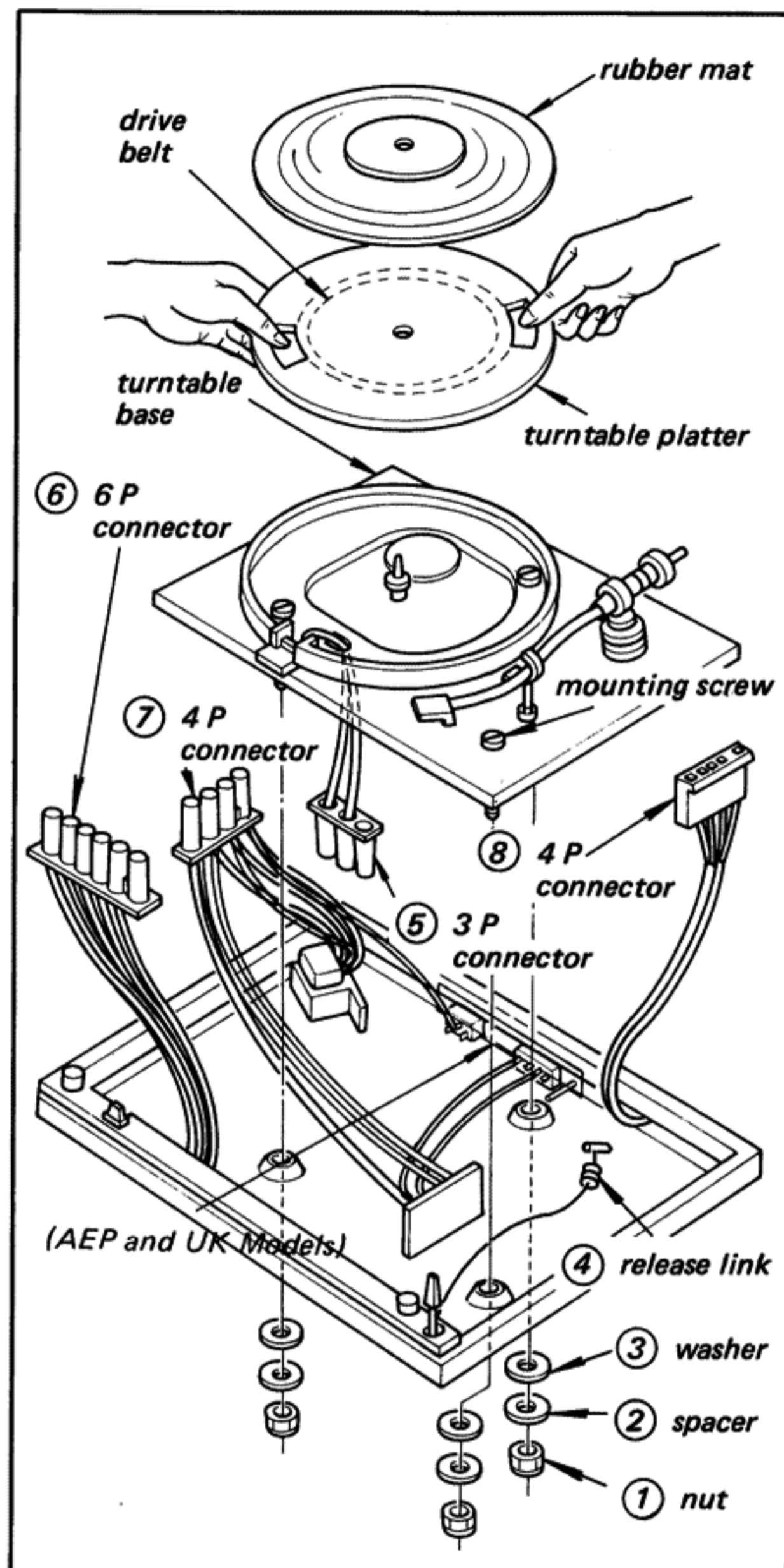

Fig. 2-2. Turntable removal

2-4. TONEARM REPLACEMENT

1. Remove the turntable base as described in Procedure 2-3.
2. Remove the shell head from the tonearm by loosening the connector.
3. Remove the counterweight from the tonearm by simply pulling it out.
4. Remove the tonearm lifting platform by removing the screw (2.6 x 4, allen-head) shown in Fig. 2-3.
5. Unsolder the five lead wires of tonearm at the terminal strip circuit board as shown in Fig. 2-4.
6. Loosen the two set screws (3 x 8, special) and pull out the tonearm lever by turning to the arrow direction as shown in Fig. 2-3.

7. Remove the nut securing the tonearm to the turntable base as shown in Fig. 2-3.
8. Install the replacement tonearm.
9. Place a piece of tube (3.3 mm dia x 20 mm) over the free end of the five lead wires and fix it with the tape on the turntable base as shown in Fig. 2-4.
10. Solder the five lead wires to the terminal strip circuit board as shown in Fig. 2-4.
11. Adjust the tonearm return position as described in Procedure 3-3 on page 14.

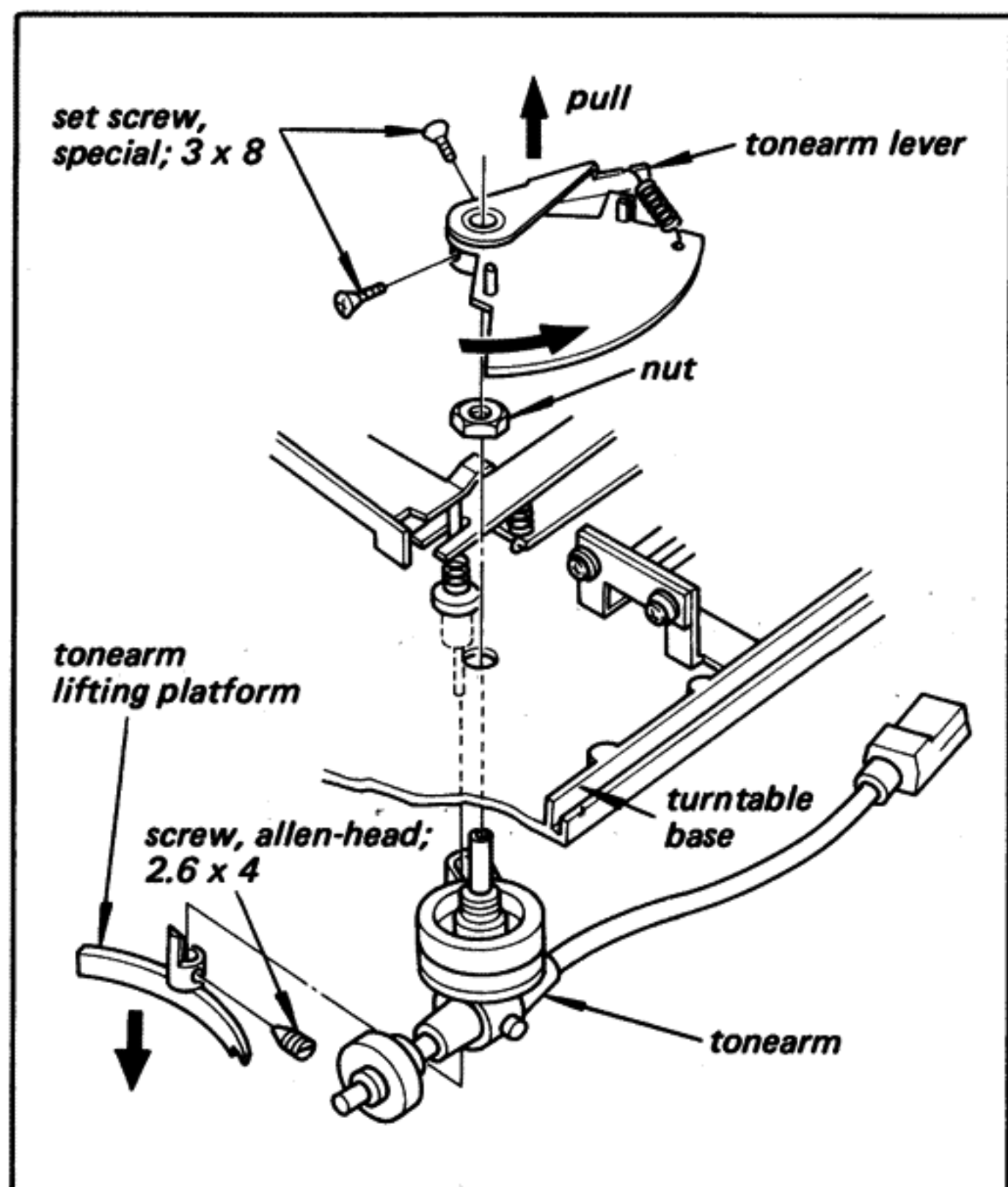

Fig. 2-3. Tonearm replacement

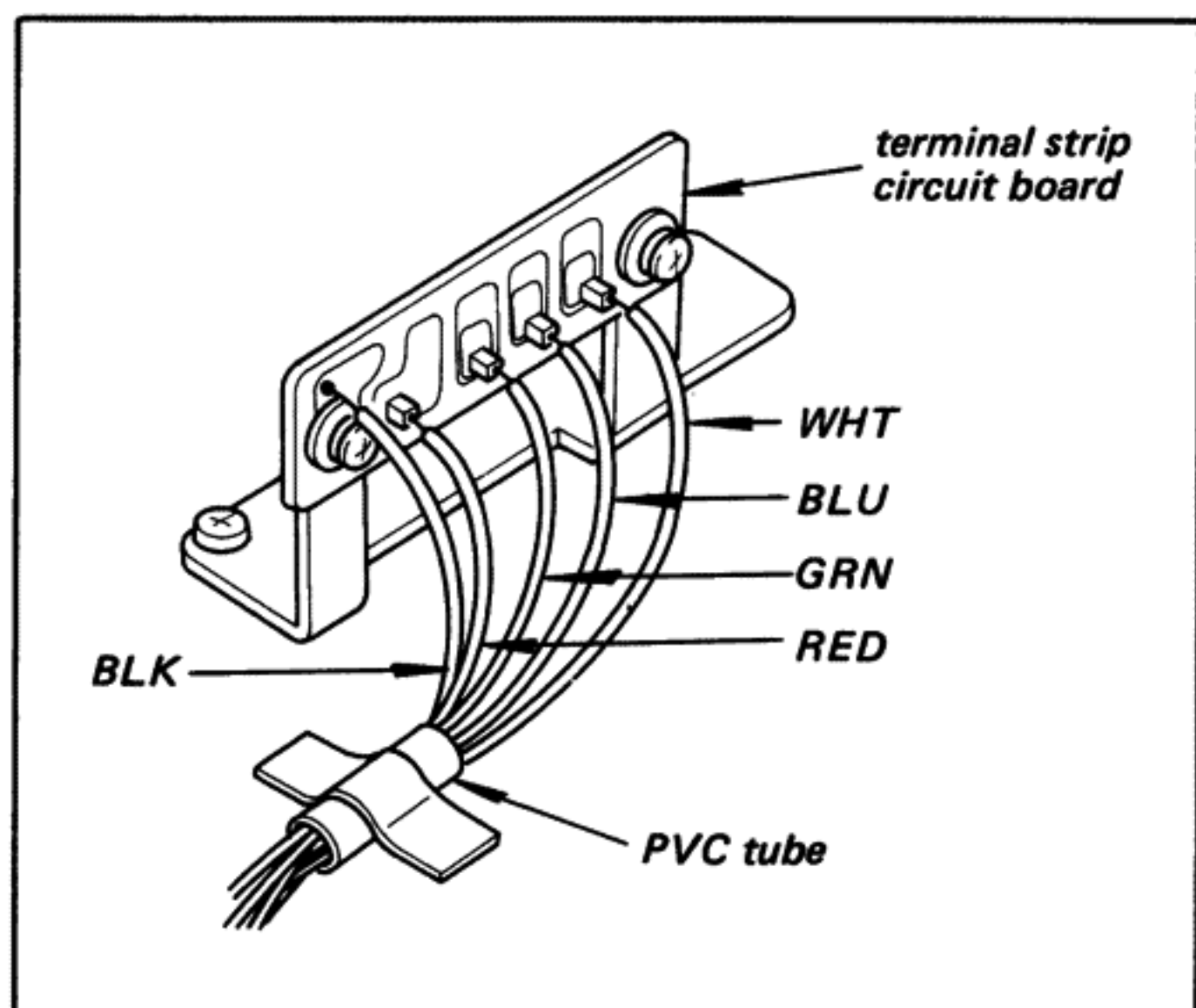

Fig. 2-4. Lead wire connection

2-5. MAIN CAM REPLACEMENT

1. Remove the turntable base as described in Procedure 2-3 on page 8.
2. Remove the trigger cam by removing the screw (PSW 3 x 5) shown in Fig. 2-5.
3. Pull out the main cam by removing the retaining ring shown in Fig. 2-5.
4. Install a new one.

Note: 1. The collars should be capped on the shafts of the return lever and the switch lever.

2. The shafts of the return lever and the switch lever should be set in the groove of the main cam.
3. The trip pawls should be moved smoothly by hand.
4. Confirm that grease is applied in the groove of the main cam.

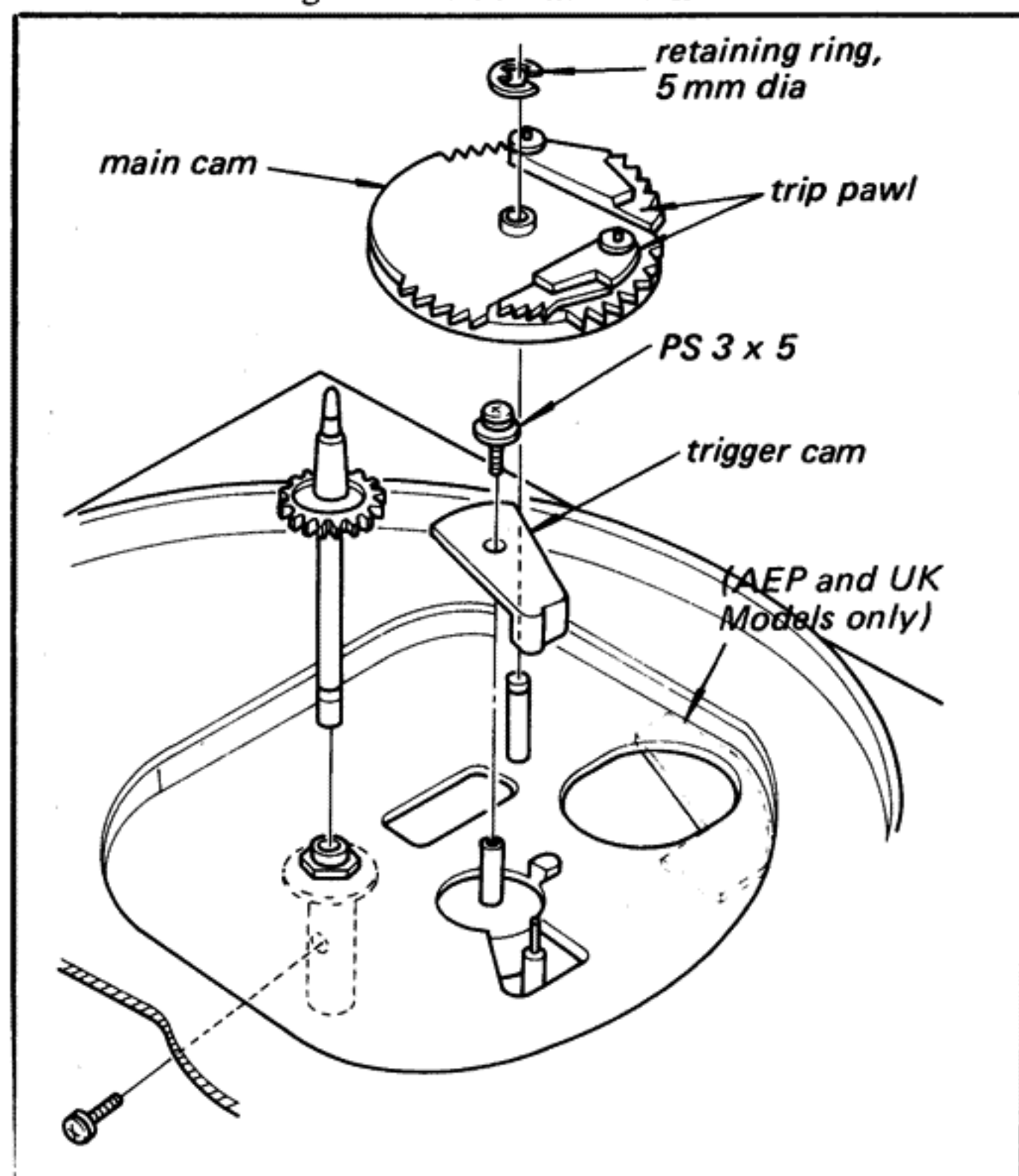

Fig. 2-5. Main cam replacement

2-6. DRIVE MOTOR REPLACEMENT

1. Remove the turntable base as described in Procedure 2-3 on page 8.
2. Unsolder the five lead wires at the servo amplifier circuit board shown in Fig. 2-6.
3. Remove the three retaining rings, three washers and three spacers shown in Fig. 2-6.
4. Remove the motor from the motor bracket by removing the three screws (K 2.6 x 5) shown in Fig. 2-6. This frees the motor.
5. Install a new motor.

6. Tighten the three motor mounting screws and apply a drop of contact cement to the screws.

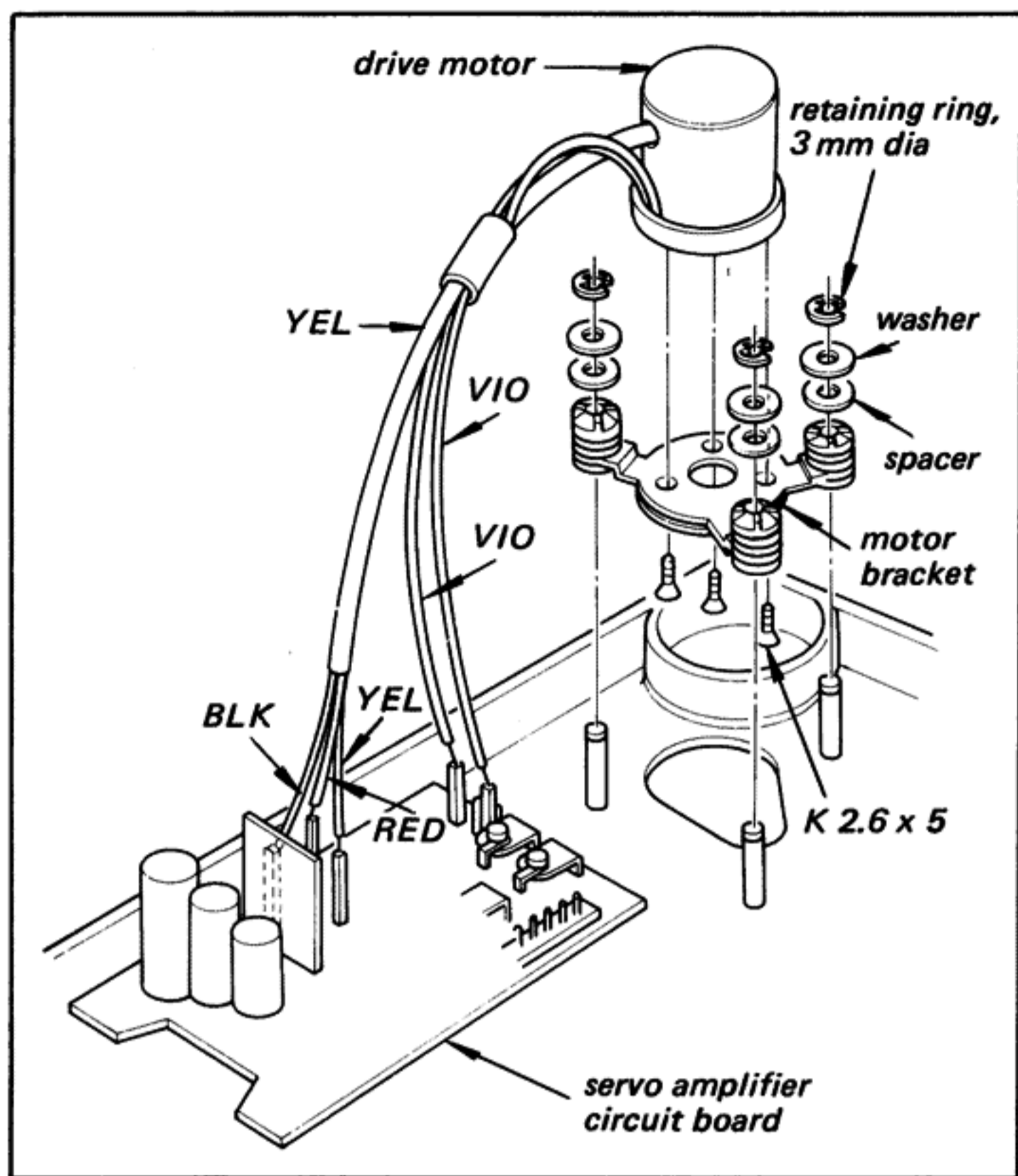

Fig. 2-6. Motor replacement

2-7. MOTOR PULLEY REPLACEMENT

1. Remove the motor from the turntable base as described in the step 3 of Procedure 2-6.
2. Pull out the pulley by loosening the set screw securing the pulley to the motor shaft with a screwdriver.
3. Install the replacement pulley, and secure the pulley with the set screw temporarily.
4. Adjust the height of the motor pulley so that the bottom of the motor pulley is 2 mm ($\frac{5}{64}$ "') higher than the top of the motor bracket as shown in Fig. 2-7 and tighten the set screw.

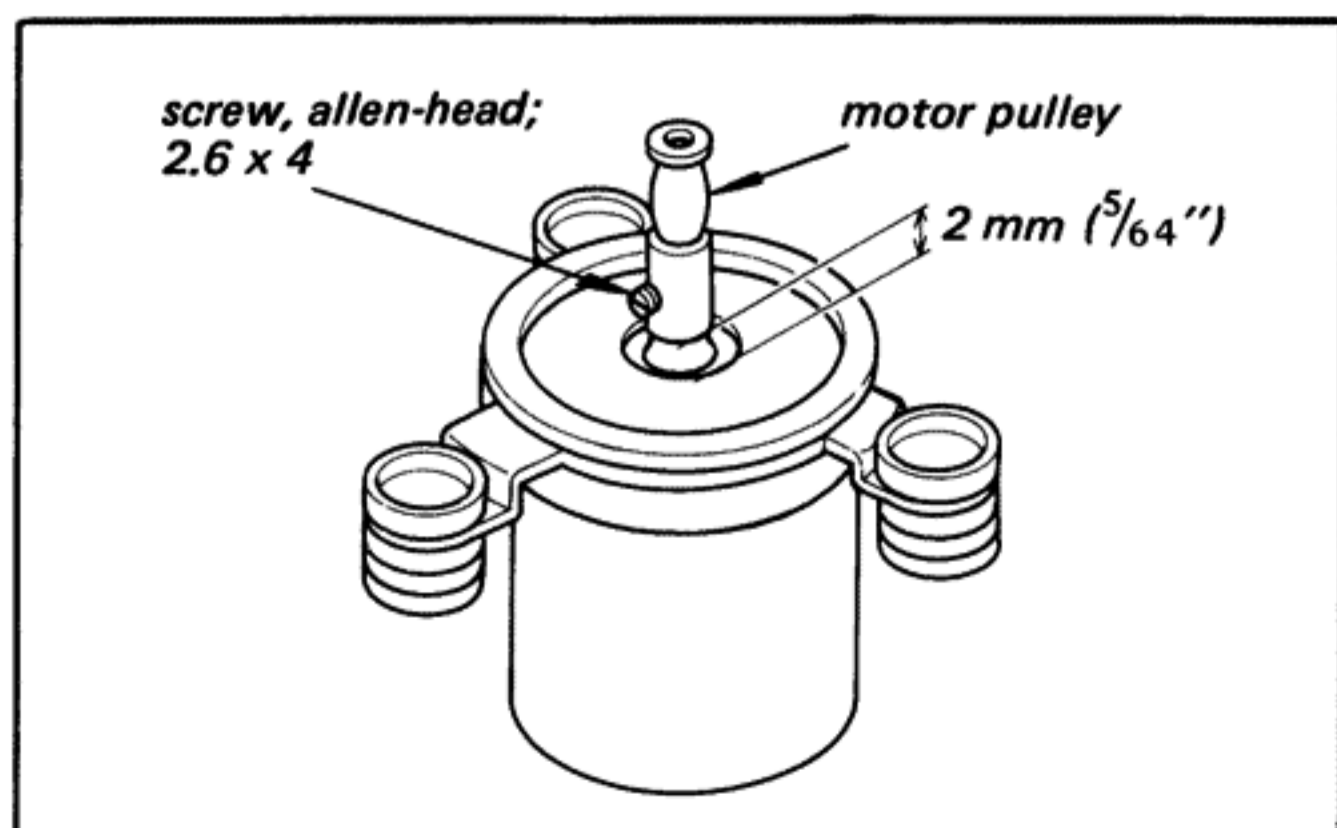

Fig. 2-7. Motor pulley replacement

2-8. TURNTABLE SHAFT REPLACEMENT

1. Remove the turntable base as described in Procedure 2-3 on page 8.
2. Remove the screw (PS 3 x 5) from the thrust bearing shown in Fig. 2-8.
3. Pull out the turntable shaft straight.
4. Apply grease (Part No. 7-662-001-11) on the lower portion of the turntable shaft as shown in Fig. 2-8 and install it.
5. Confirm that the clearance between the gear of the turntable shaft and the trip pawl is 0.5 ~ 1 mm ($\frac{1}{64}$ ~ $\frac{3}{64}$ "') as shown in Fig. 2-9.

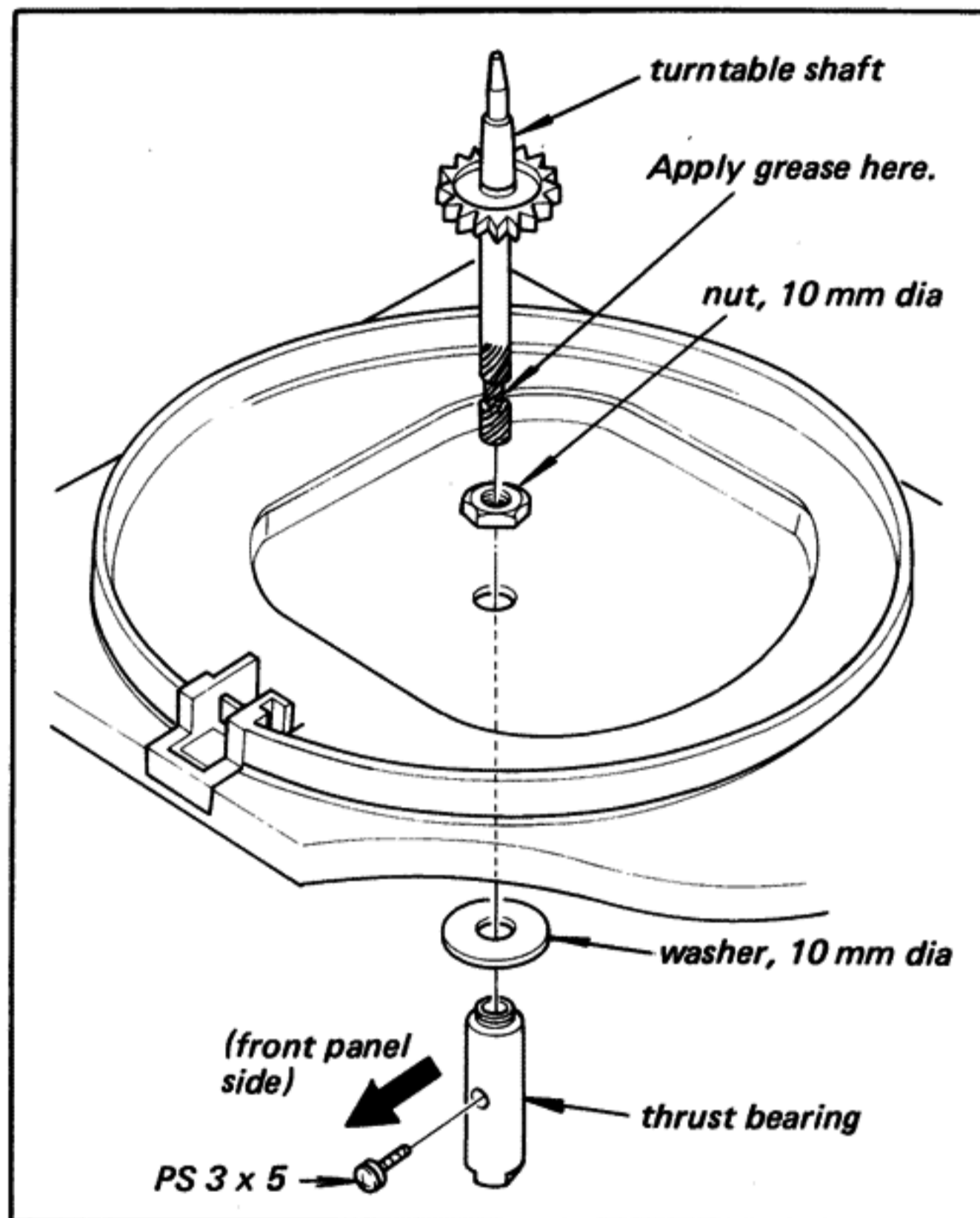

Fig. 2-8. Turntable shaft replacement

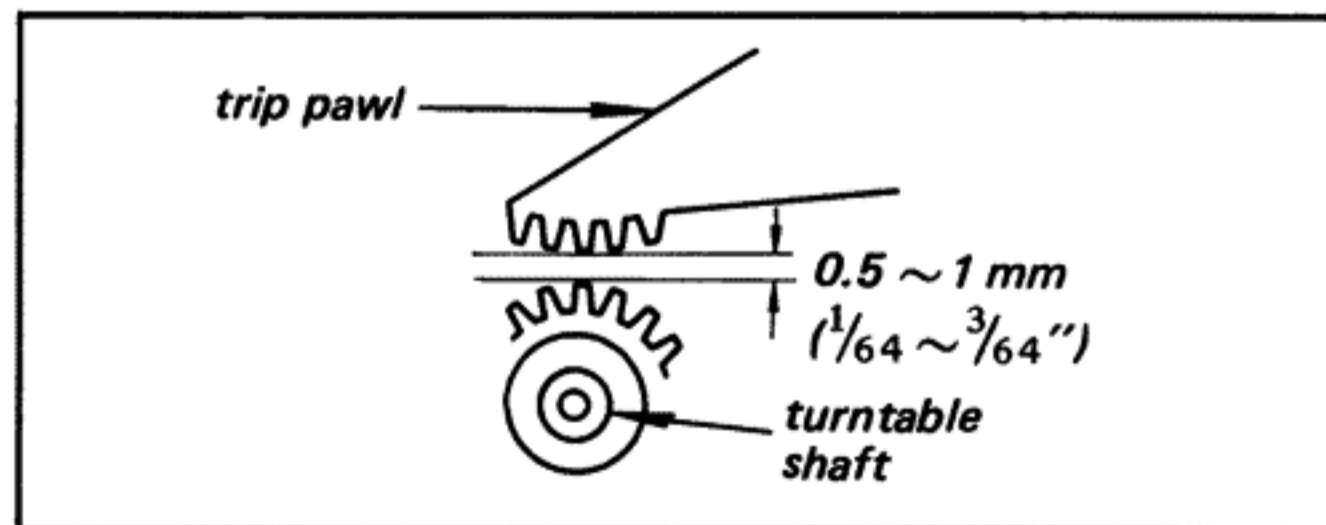

Fig. 2-9. Turntable shaft adjustment

2-9. TURNTABLE THRUST BEARING REPLACEMENT

1. Remove the turntable shaft as described in Procedure 2-8.
2. Remove the nut (10 mm dia) and washer (10 mm dia) as shown in Fig. 2-8. This frees the thrust bearing.

- When installing the thrust bearing, the head of the screw (PS 3 x 5) should be in the direction of the front panel as shown in Fig. 2-8.

2-10. CDS REPLACEMENT

- Remove the turntable base as described in Procedure 2-3 on page 8.
- Unsolder the two lead wires of CDS at the printed circuit board as shown in Fig. 2-10.
- Remove the CDS holder by removing the screw (B 3 x 6, self-tapping) shown in Fig. 2-10.
- Remove the cellophane tape on CDS and replace CDS.
- Proceed to "Shutter Position Adjustment at Automatic Return" on page 14.

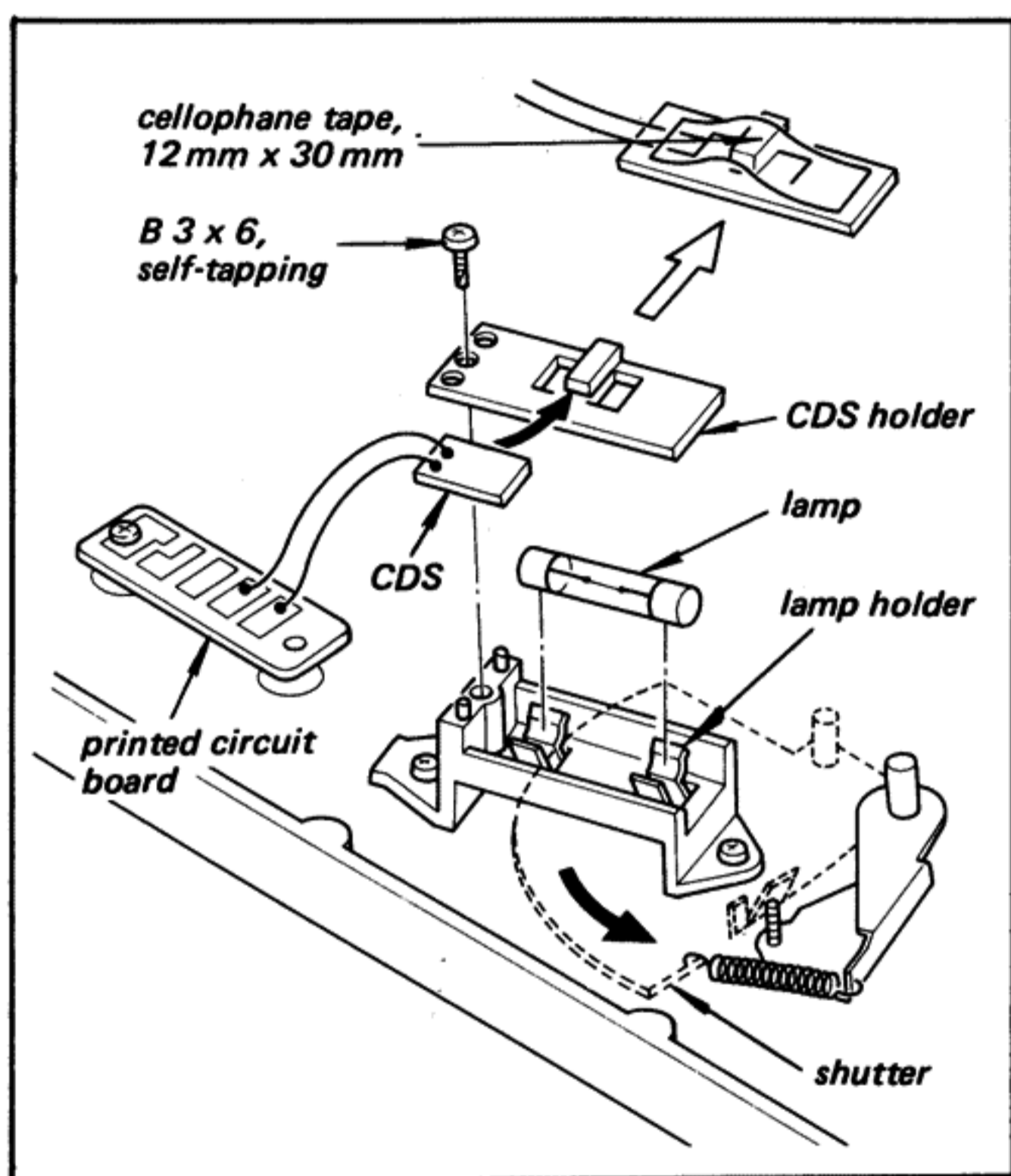

Fig. 2-10. CDS replacement

2-11. LAMP REPLACEMENT

- Remove the turntable base as described in Procedure 2-3 on page 8.
- Remove the CDS holder by removing the screw (B 3 x 6, self-tapping) shown in Fig. 2-10.
- Move the tonearm toward the turntable shaft to remove the shutter of the tonearm lever from the lamp holder as shown in Fig. 2-10.
- Remove the lamp and install a new lamp.
- Proceed to "Lamp Brightness Adjustment When Opening Shutter Completely" on page 14.

2-12. AUTO-RETURN TRIGGER MOTOR REPLACEMENT

- Remove the turntable base as described in Procedure 2-3 on page 8.
- Remove the trigger cam by removing the screw (PS 3 x 5).
- Unsolder the two lead wires at the terminals of the motor as shown in Fig. 2-11.
- Remove the trigger motor bracket by removing the screw (B 3 x 6, self-tapping) shown in Fig. 2-11. This frees the motor.
- Install a new motor.
- When installing the motor, be careful to the polarity of the motor as shown in Fig. 2-11.

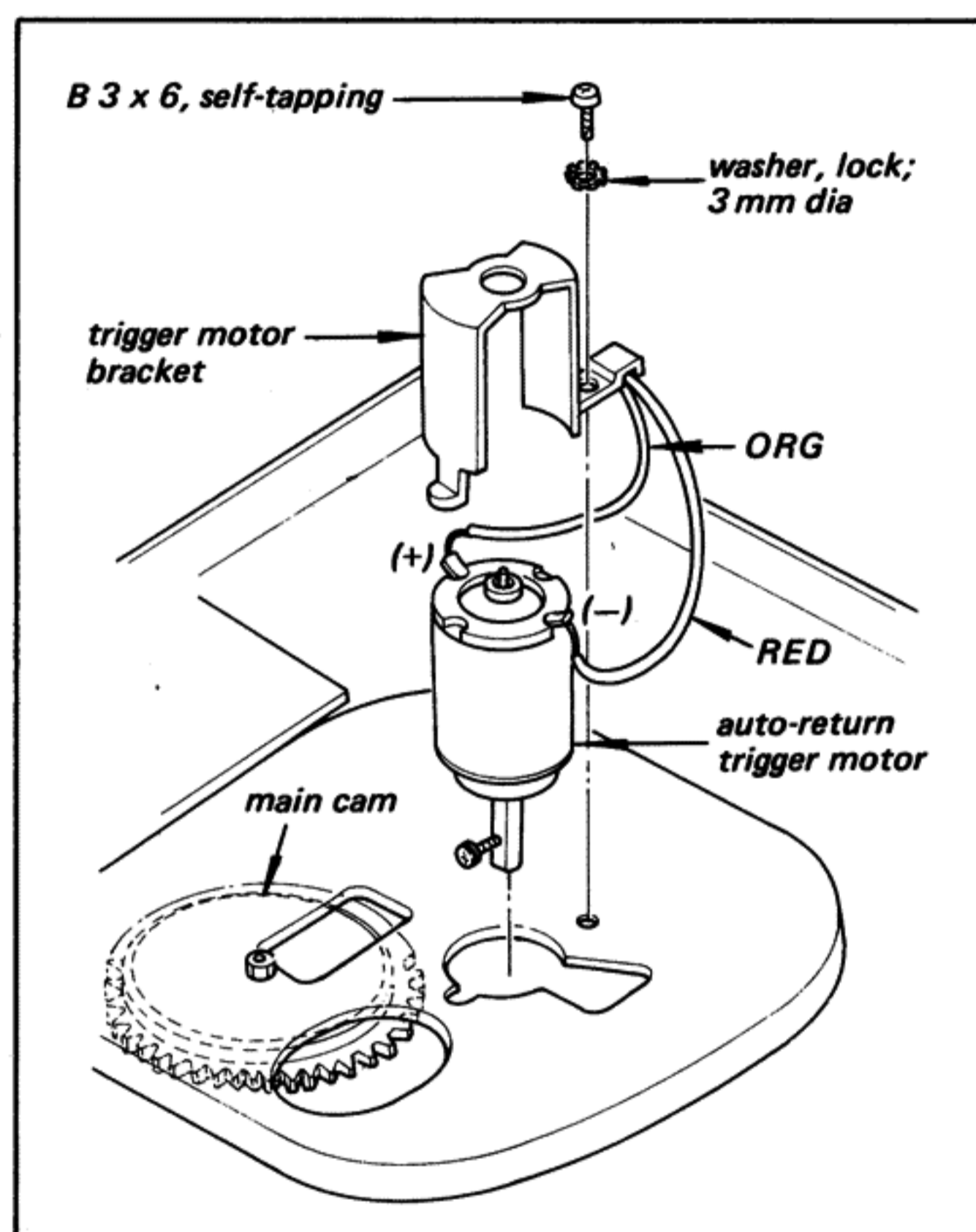

Fig. 2-11. Auto-return trigger motor replacement

2-13. RELEASE LINK REPLACEMENT

- Remove the turntable base as described in Procedure 2-3 on page 8.
- Remove the front panel carefully by removing the three screws (P 2.6 x 4) and the three screws (K 3 x 6) shown in Fig. 2-12.
- Remove the springs ① ②, pushbuttons ③ ④, and START/STOP button shaft ⑤ shown in Fig. 2-12.

- Remove the front subchassis by removing the three screws (B 3 x 8, self-tapping) shown in Fig. 2-12.

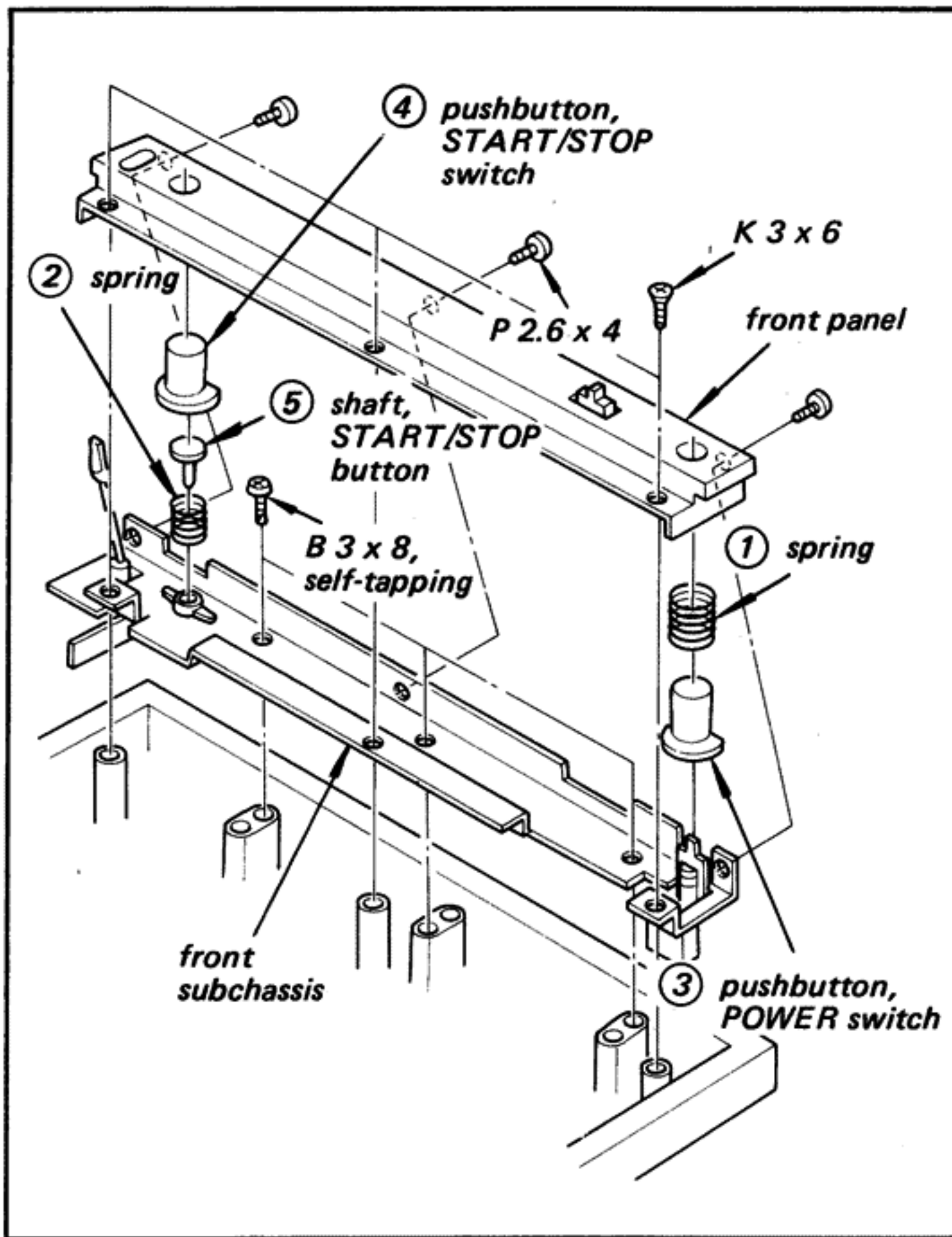

Fig. 2-12. Front panel/front subchassis removal

- Remove the lifter ass'y downwards by removing the two screws (PS 3 x 5) as shown in Fig. 2-13.
- Remove the retaining ring (2.8 mm dia) and the torsion spring shown in Fig. 2-13.
- Remove the lifter cam by removing the retaining ring (3 mm dia) shown in Fig. 2-13.
- Pull out the release link from the lifter cam as shown in Fig. 2-13. This frees the release link.

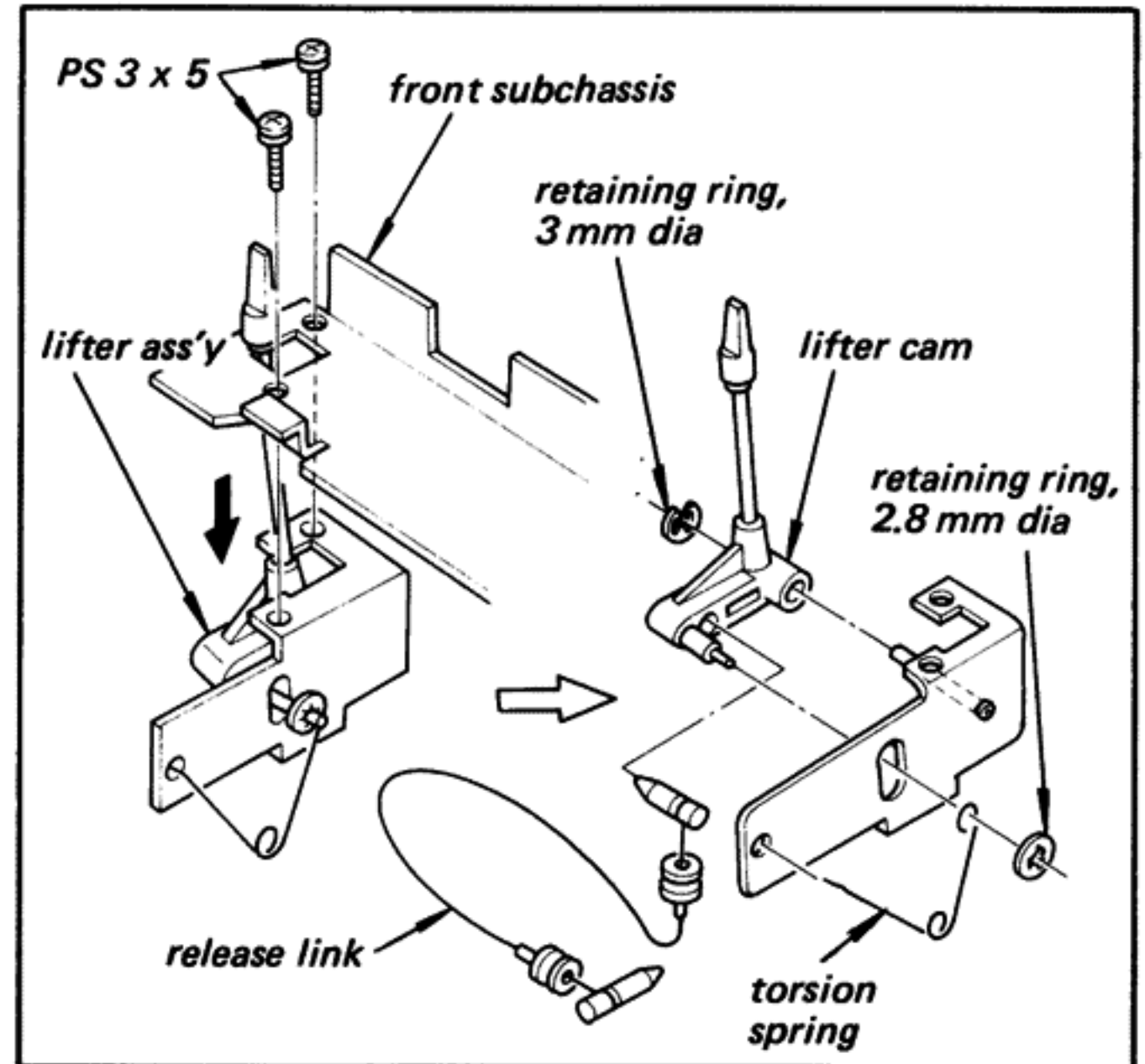

Fig. 2-13. Lifter ass'y/release link removal

SECTION 3 ADJUSTMENTS

3-1. TONEARM HEIGHT ADJUSTMENT

A) Automatic Return Operation

When the tonearm automatically returns to its rest after playing, confirm that the clearance between the stylus tip and the record on the turntable is 5 ~ 7.5 mm ($\frac{3}{16}$ " ~ $\frac{5}{16}$ ") and simultaneously the height of the finger hook is within 60 mm ($\frac{3}{8}$ ") above the turntable base as shown in Fig. 3-1.

If not, adjust the height of the tonearm lifting platform by loosening the allen-head screw shown in Fig. 3-2.

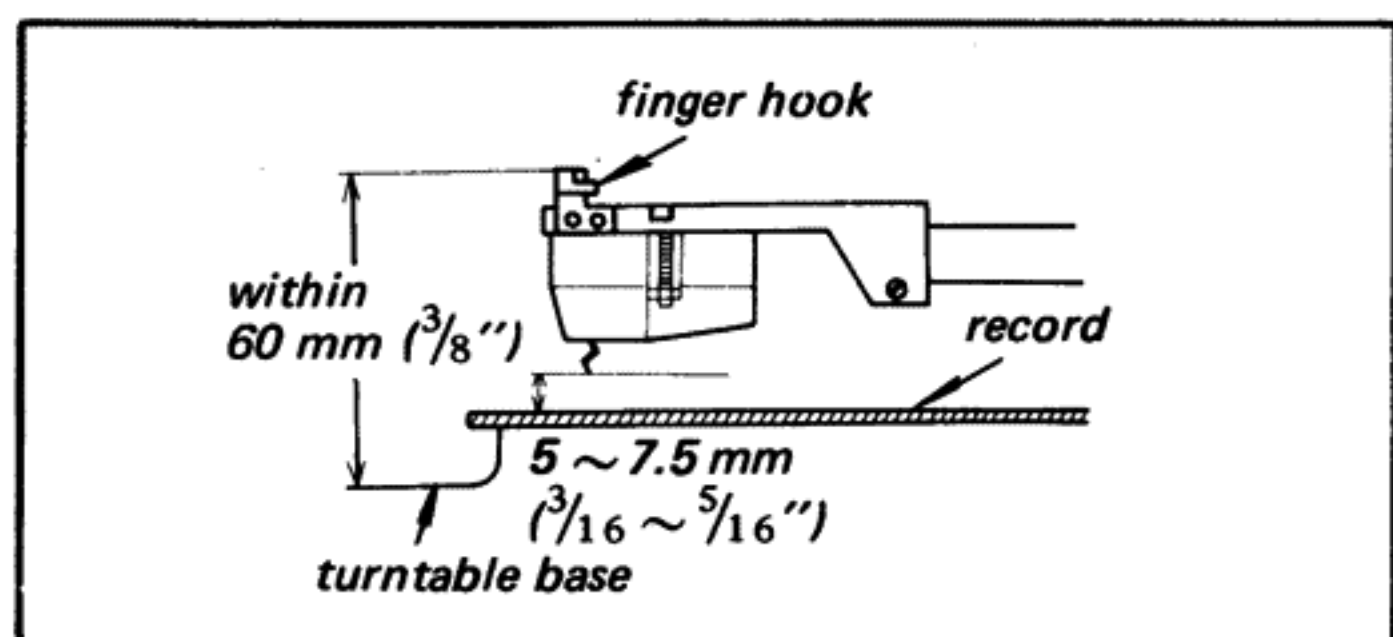

Fig. 3-1. Clearance between stylus tip and record

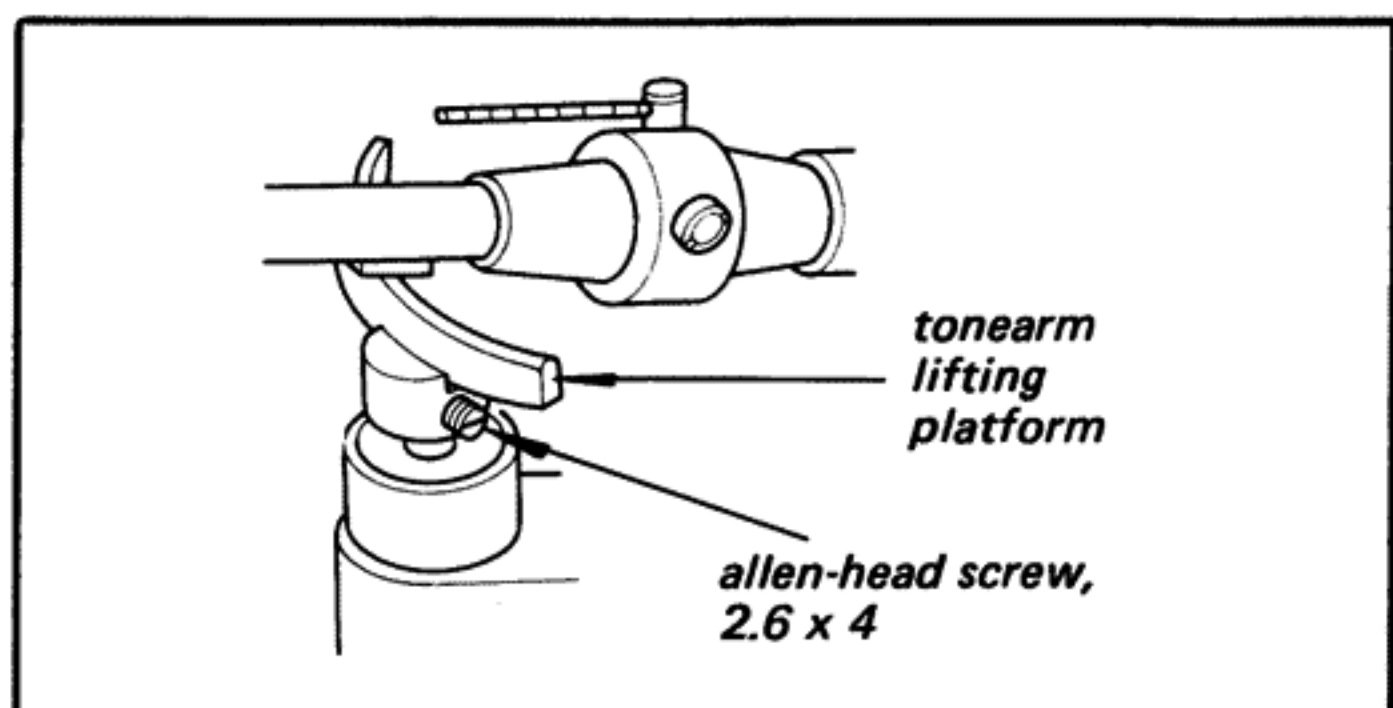

Fig. 3-2. Tonearm lifting platform height adjustment

B) Manual Return Operation

Note: Before starting this adjustment, the above adjustment (Automatic Return Operation) should be performed.

1. Set the lifter lever to "UP" position.
2. Turn the adjustment screw so that the edge of the tonearm lifter lever ① contacts the retaining ring ② on the tonearm lifting rod as shown in Fig. 3-3.

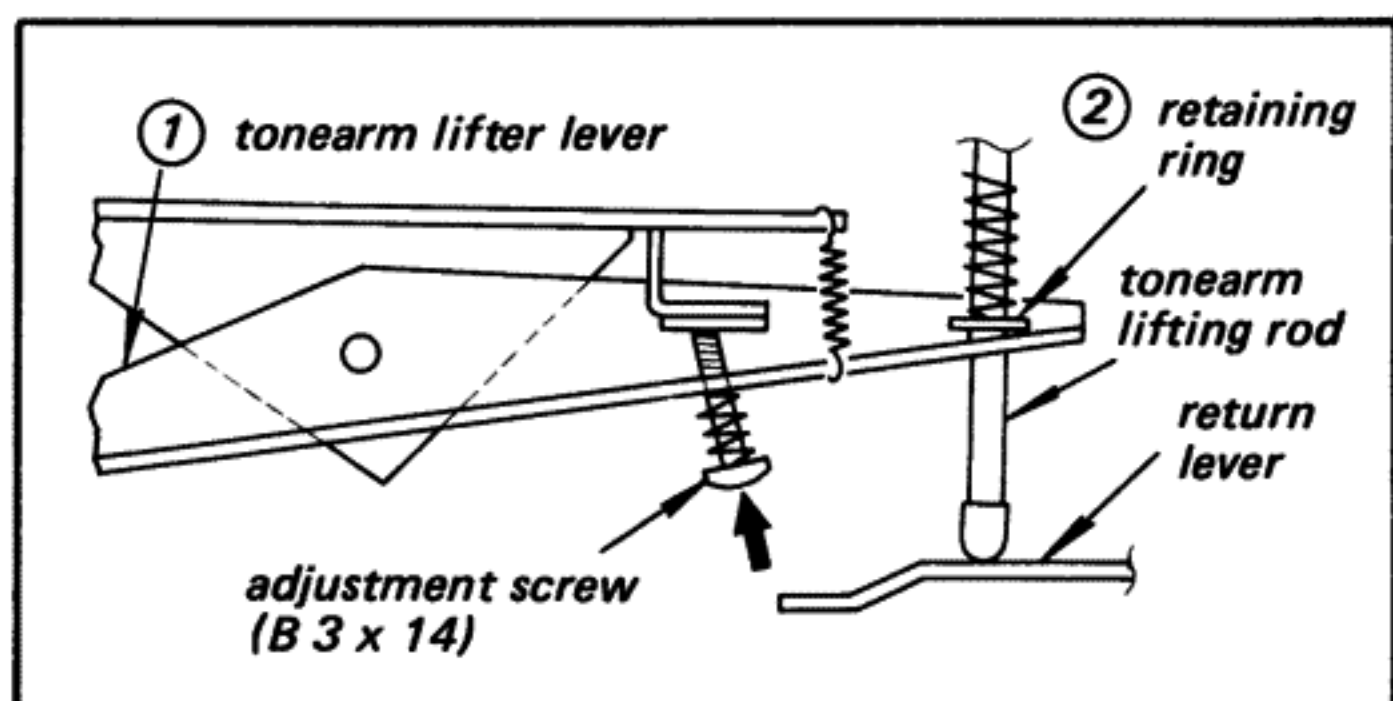

Fig. 3-3. Tonearm height adjustment in manual return operation

3. Confirm that the clearance between the stylus tip and the record on the turntable is 4 mm ~ 6 mm ($\frac{6}{32}$ " ~ $1\frac{5}{64}$ ").

C) Tonearm Rest Height Adjustment

After performing the preceding adjustments (A, B), adjust the height of the tonearm rest by loosening the set screw so that the tonearm is set on the tonearm rest as shown in Fig. 3-4.

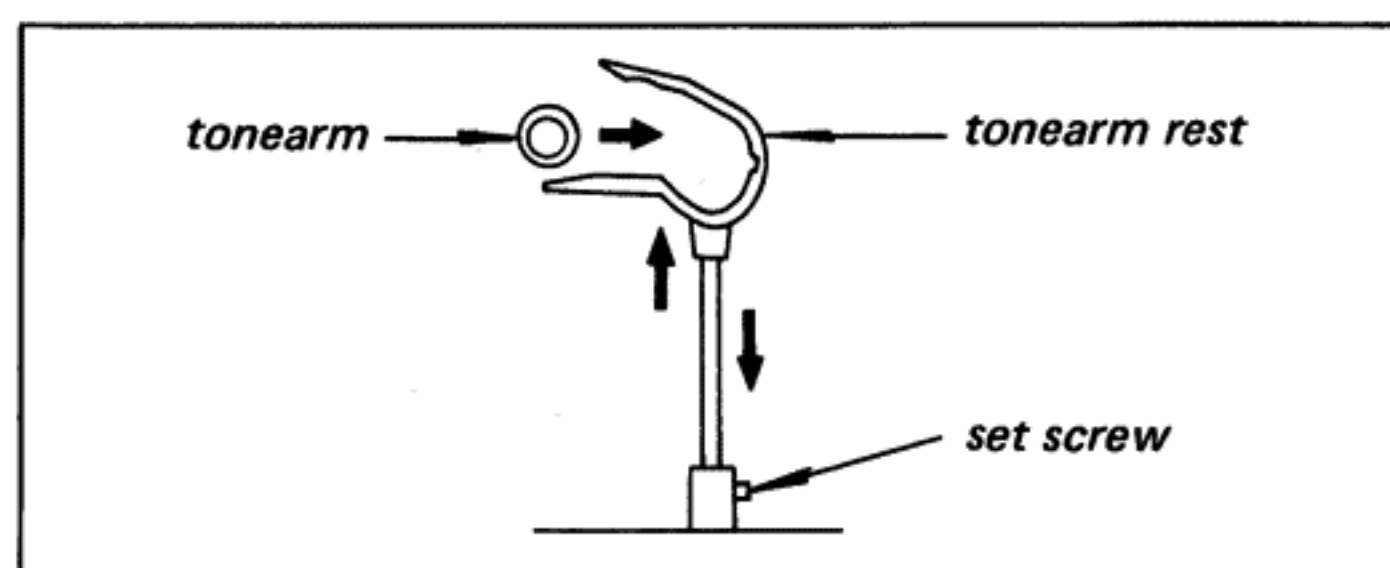

Fig. 3-4. Tonearm rest height adjustment

3-2. TURNTABLE SPEED ADJUSTMENT

1. Turn the two speed control knobs to the mechanical-mid position as shown in Fig. 3-5.
2. Adjust R29 (33 rpm) and R30 (45 rpm) shown in Fig. 3-6 so that the stroboscope pattern appears stationary.

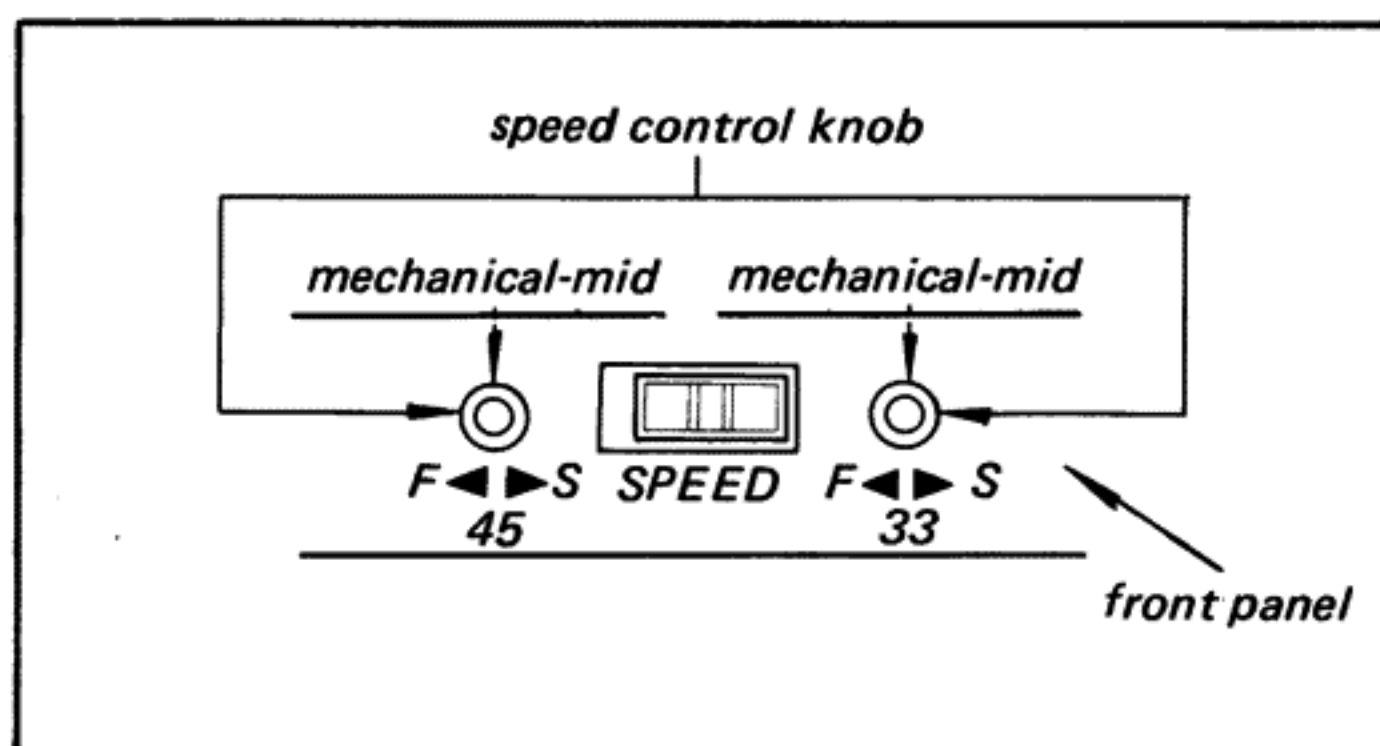

Fig. 3-5. Turntable speed adjustment

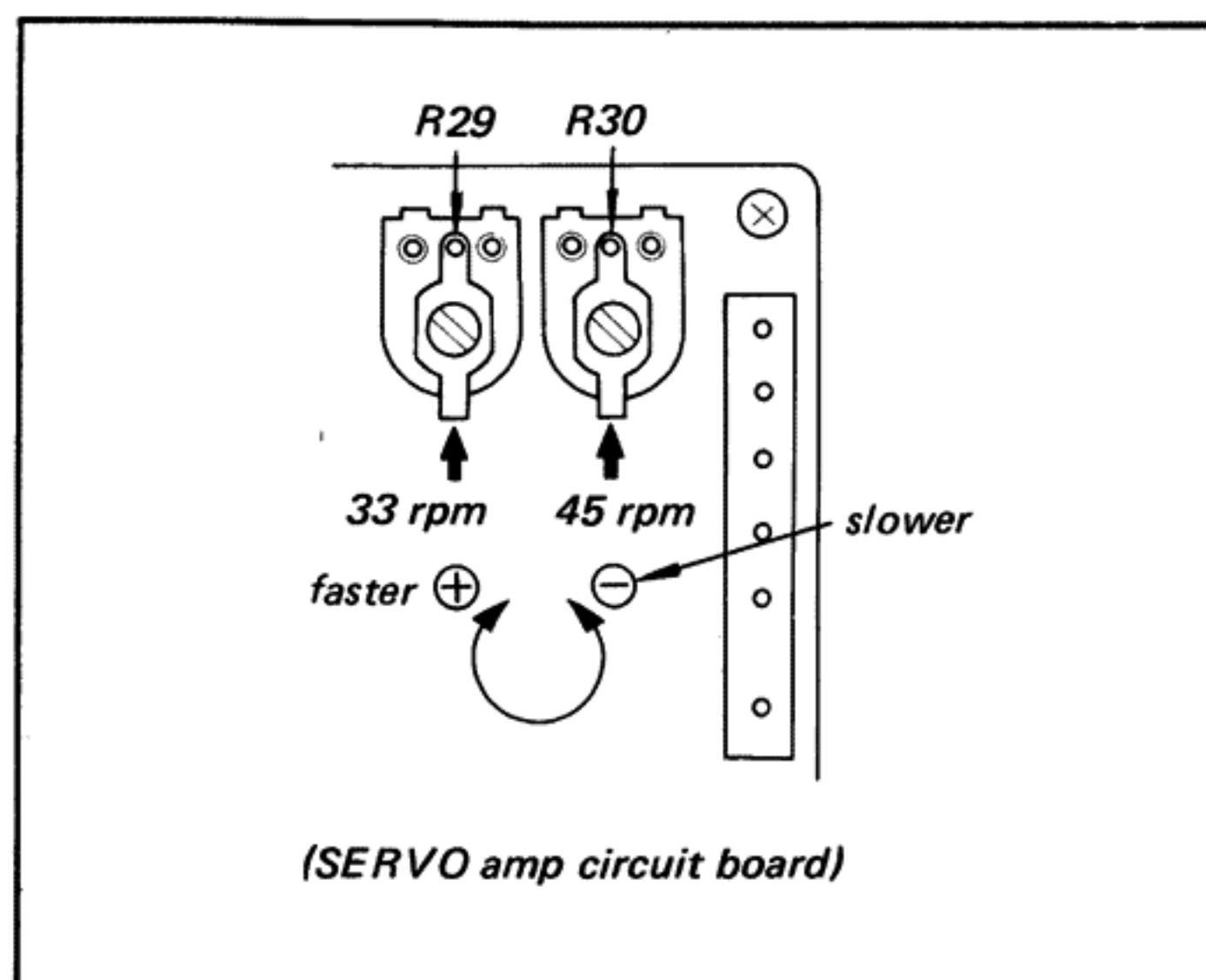

Fig. 3-6. Adjustment parts location

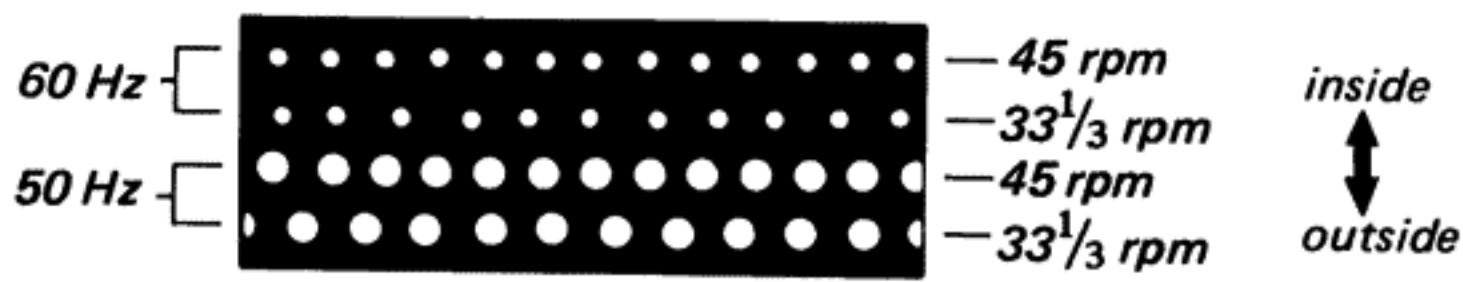

Fig. 3-7. Stroboscope patterns on the mirror

3-3. AUTOMATIC RETURN ADJUSTMENT

A) Trigger Level Adjustment

1. Set the voltmeter (20 k Ω /V) to 10 V range.
2. Place the tonearm on the tonearm rest.
3. Turn the POWER switch "ON".
4. Set the START/STOP switch to "START".
5. Connect the positive side of VOM to R19 ① and the negative side to R15 ② as shown in Fig. 3-8.
6. Adjust R32 (See Fig. 3-8.) so that the VOM reads 1.55 ± 0.05 V.

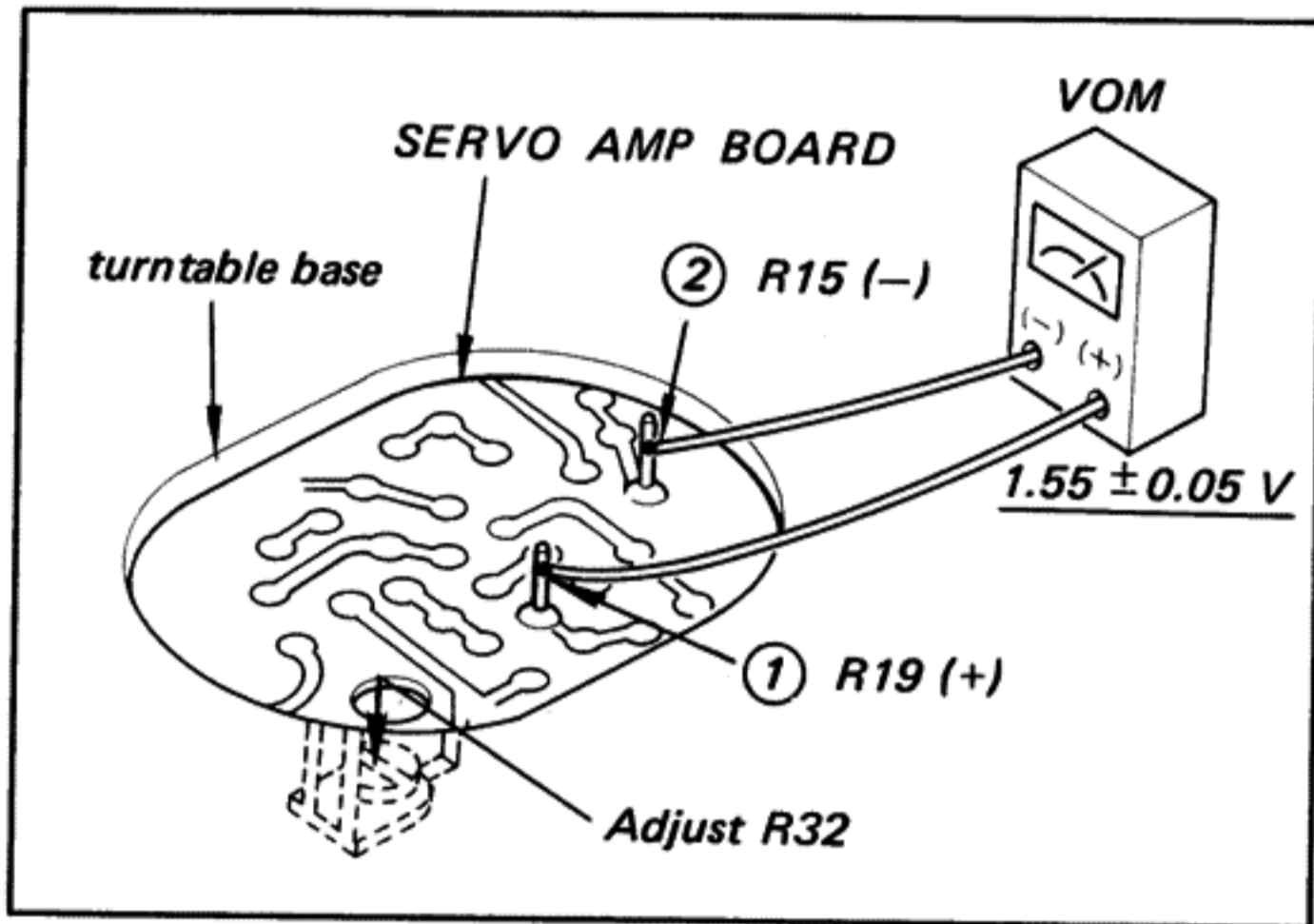

Fig. 3-8. Trigger level adjustment

B) Lamp Brightness Adjustment When Opening Shutter Completely

1. Turn the POWER switch "ON".
2. Set the START/STOP switch to "START".
3. Connect the VOM across R16 ③ and ④ as shown in Fig. 3-9.
4. Bring the tonearm toward the turntable shaft as far as it will go.
5. Adjust R31 (See Fig. 3-9) so that the VOM reads 9 ± 0.5 V.

C) Shutter Position Adjustment at Automatic Return

1. The stylus tip should be 54 mm ($2\frac{1}{8}$ ") away from the turntable shaft as shown in Fig. 3-10.
2. Turn the lifter lever "DOWN".

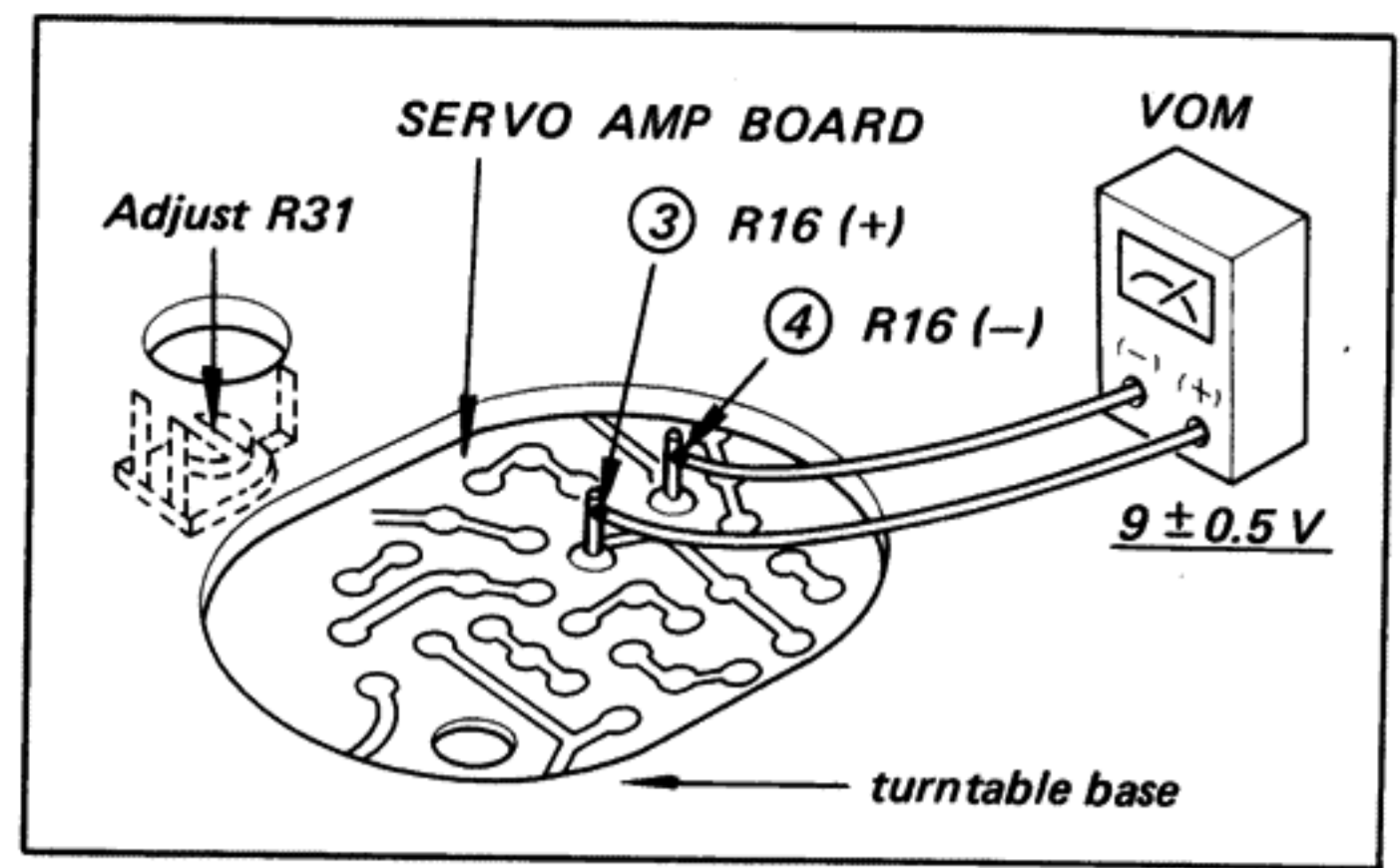

Fig. 3-9. Lamp brightness adjustment when opening shutter completely

3. Rotate the main cam counterclockwise by hand until the gear portion of the trip pawl (B) faces the turntable shaft as shown in Fig. 3-11. At this time, the tonearm lowers.
4. Turn the POWER switch "ON".
5. Connect the VOM across R16 ③ and ④ as shown in Fig. 3-12.
6. Adjust the position of the shutter by turning the adjustment screw (See Fig. 3-13.) so that the VOM reads 4.5 ± 0.5 V.

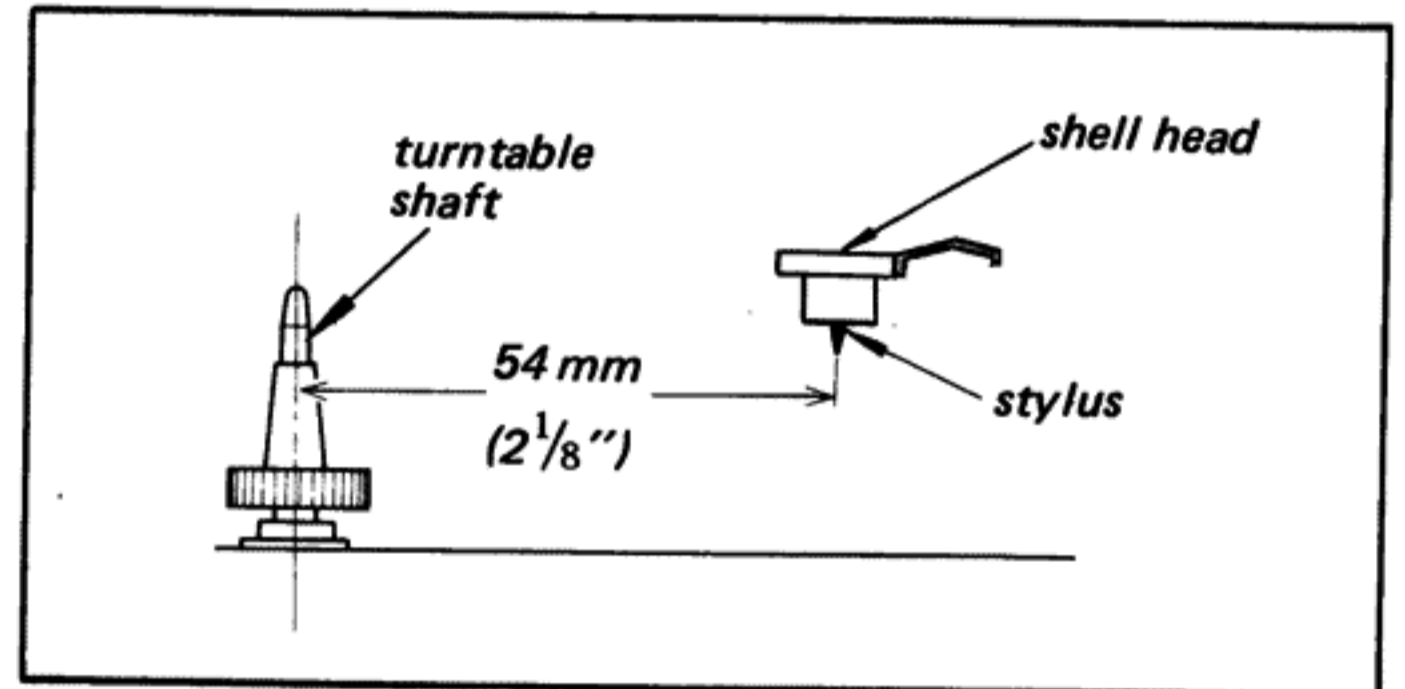

Fig. 3-10. Distance between turntable shaft and stylus

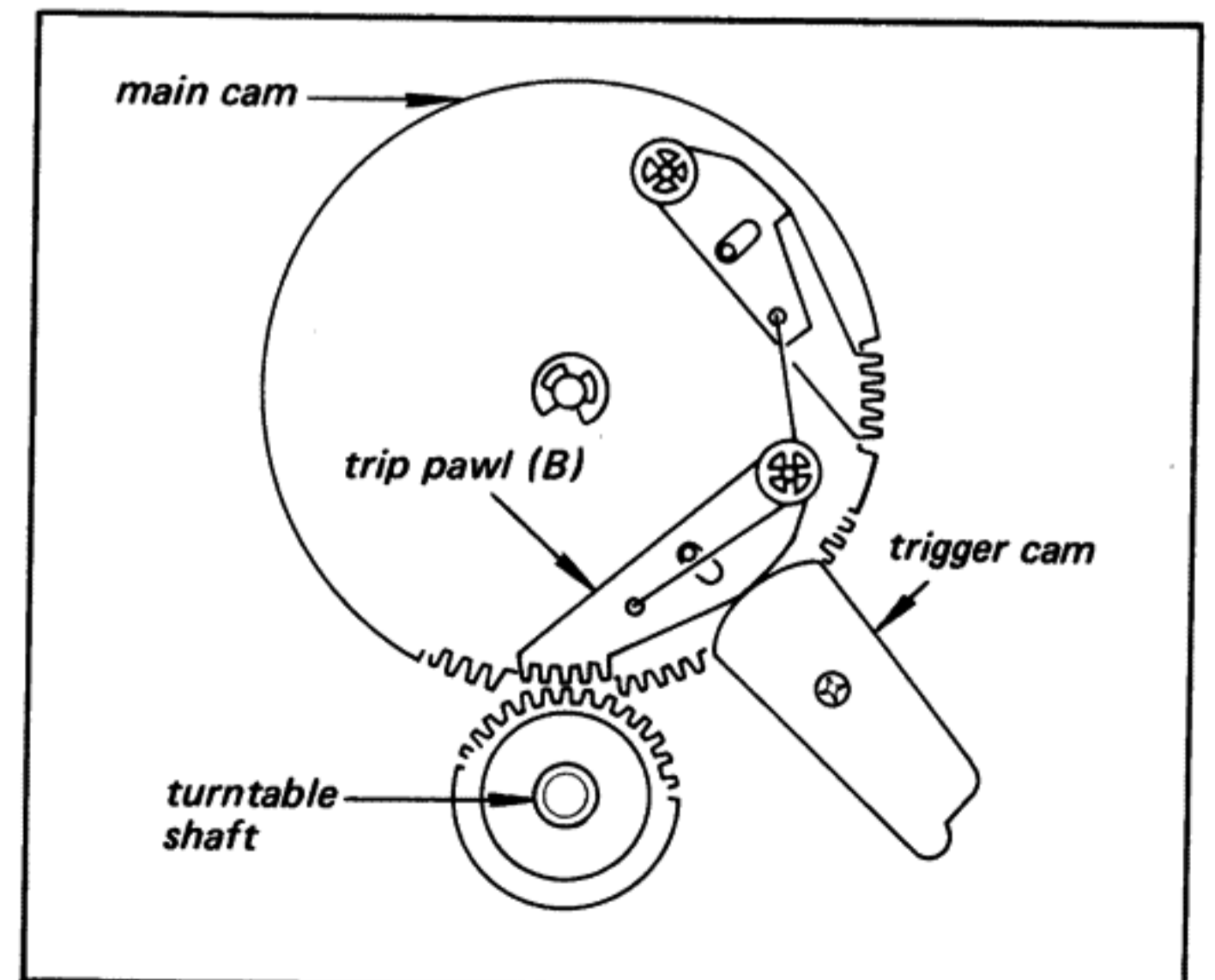

Fig. 3-11. Tonearm lowering position

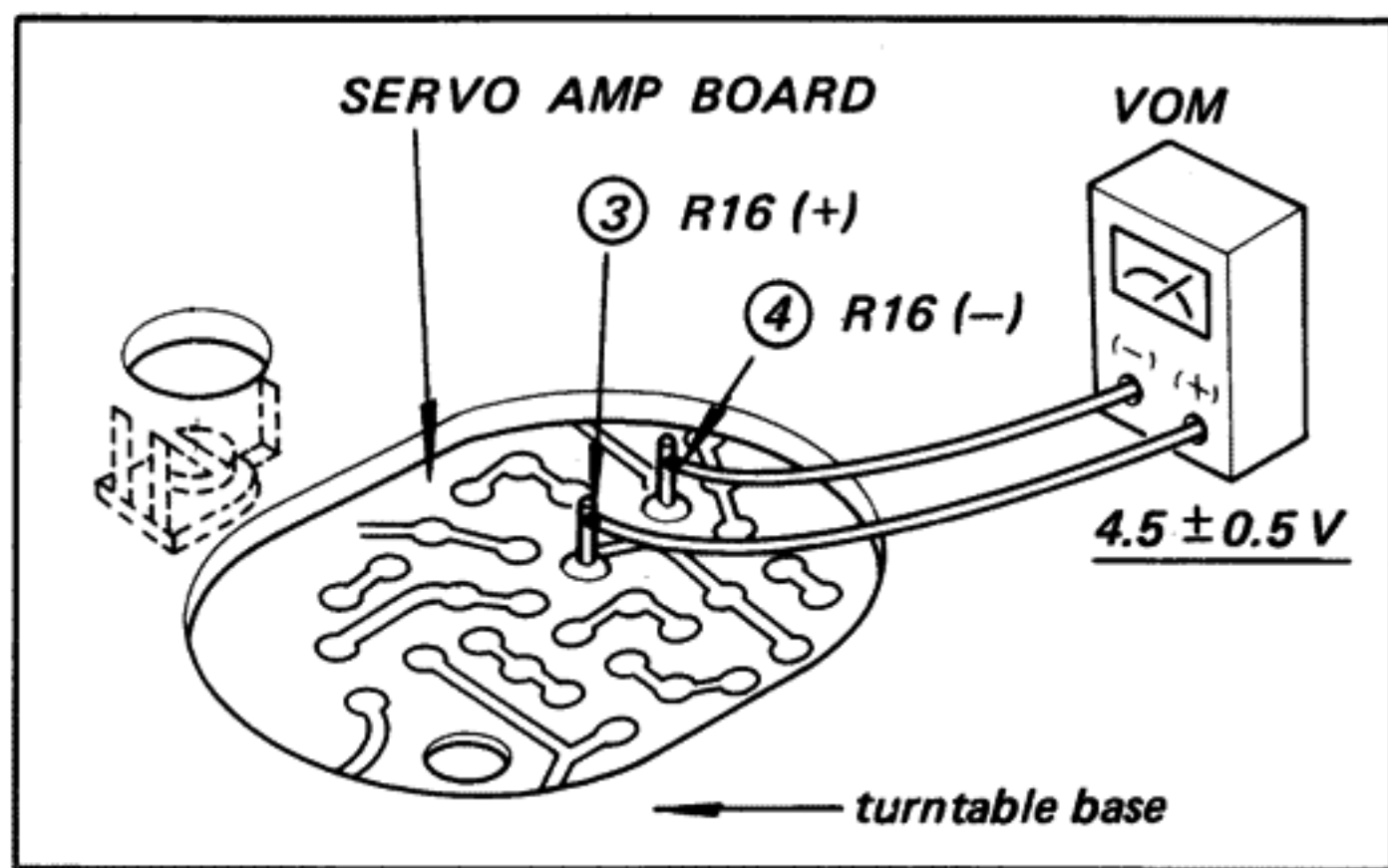

Fig. 3-12. Shutter position adjustment (1)

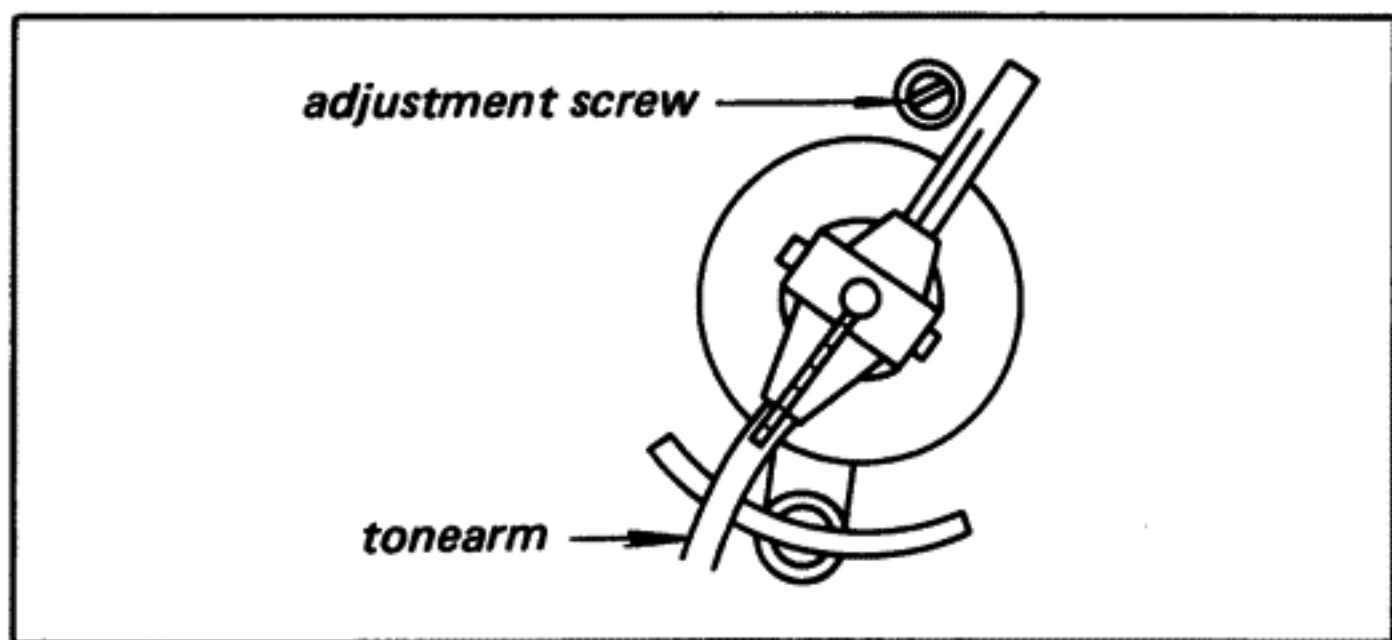

Fig. 3-13. Shutter position adjustment (2)

D) Operational Check at Automatic Return by Using a Record

After completing the preceding adjustments (A, B, C), check the automatic return operation by using a record. If it is not working properly, adjust by turning the adjustment screw as shown in Fig. 3-13.

Note: Refer to Table 3-1.

Table 3-1. Automatic return position adjustment

Automatic return position	Turning direction of adjustment screw
Too fast	Clockwise
Too slow	Counterclockwise

3-4. MICROSWITCH ADJUSTMENT

1. With the trip pawl (A) not engaging with the turntable shaft, adjust by turning the adjustment screw so that the clearance between the switch arm and the microswitch is 0.4 ~ 0.5 mm ($\frac{1}{64}$ "') as shown in Fig. 3-14.

Note: When the specified clearance is obtained, the microswitch is in off position.

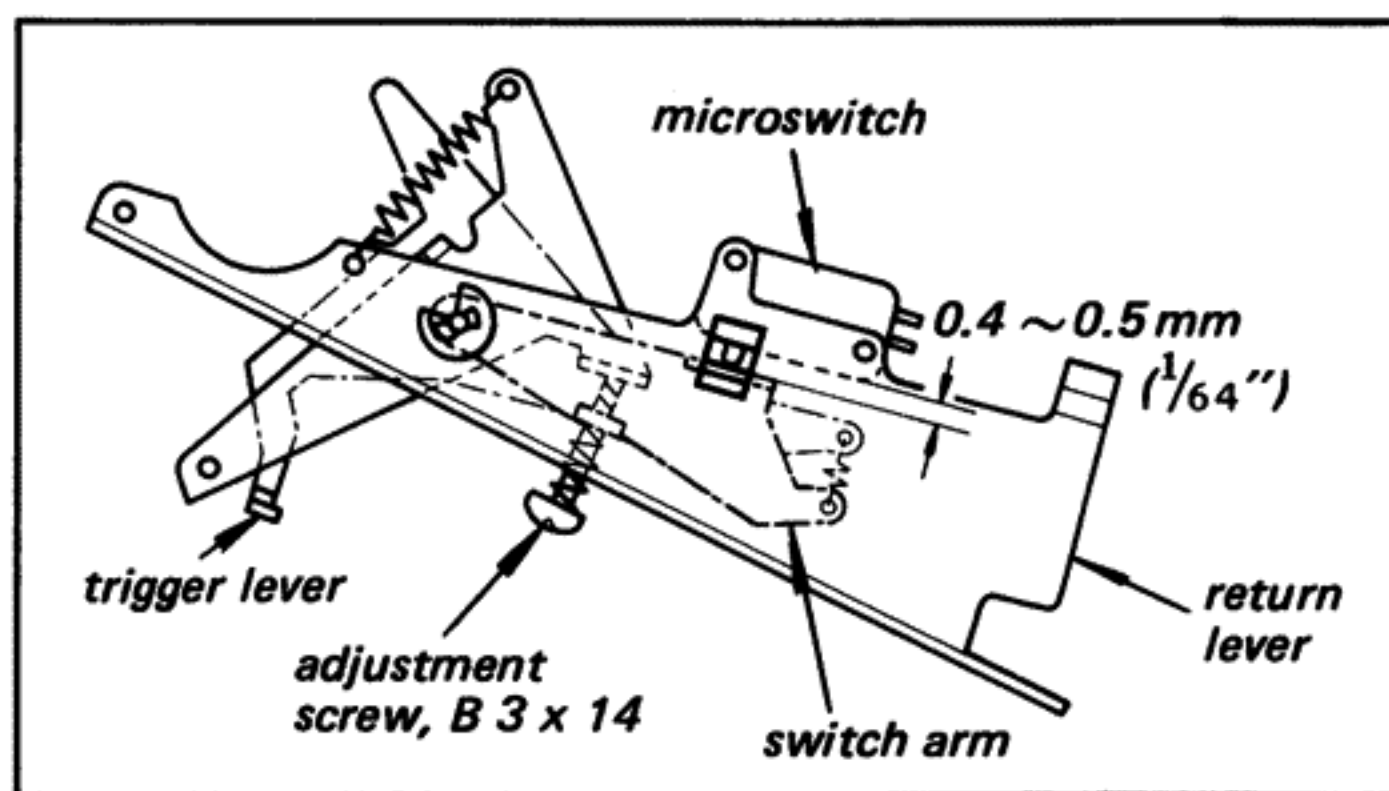

Fig. 3-14. Microswitch adjustment (1)

2. Mesh the trip pawl (A) and the turntable shaft by moving the trigger cam in the arrow direction shown in Fig. 3-15.

Confirm that the plunger of microswitch is not in contact with the switch arm.

The microswitch becomes on.

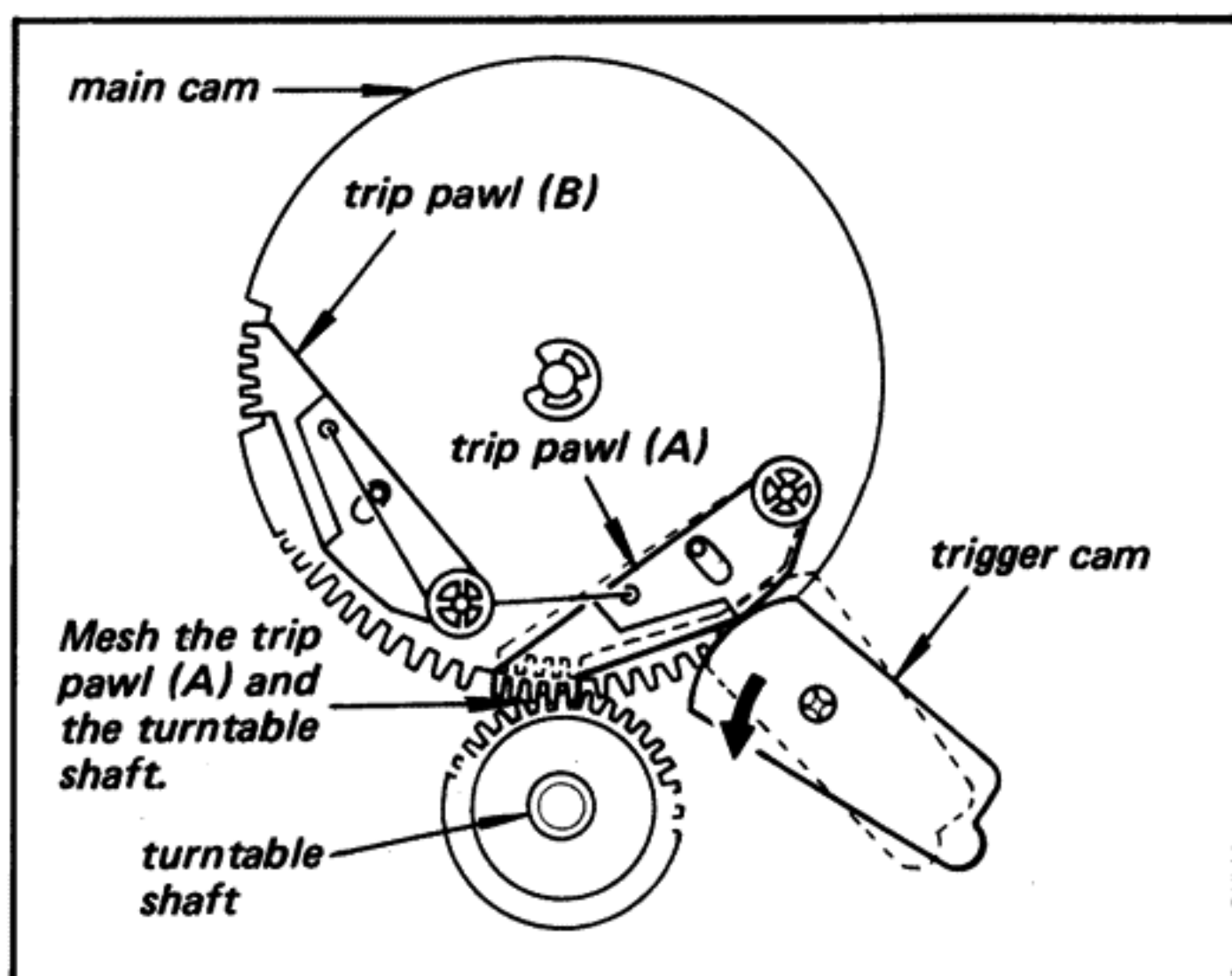

Fig. 3-15. Microswitch adjustment (2)

3. Rotate the main cam counterclockwise by hand until the gear portion of the trip pawl (B) faces the turntable shaft.

Confirm that the plunger of microswitch is not in contact with the switch arm.

(At this time, the tonearm lowers and the play begins.)

4. Mesh the trip pawl (B) and the turntable shaft by moving the trigger cam in the arrow direction shown in Fig. 3-16.

5. While rotating the main cam counterclockwise, confirm that the plunger of microswitch is not contact with the switch arm.

Note: After completing step 5, make sure to return to step 1 correctly.

6. Apply a drop of contact cement to the adjustment screw.

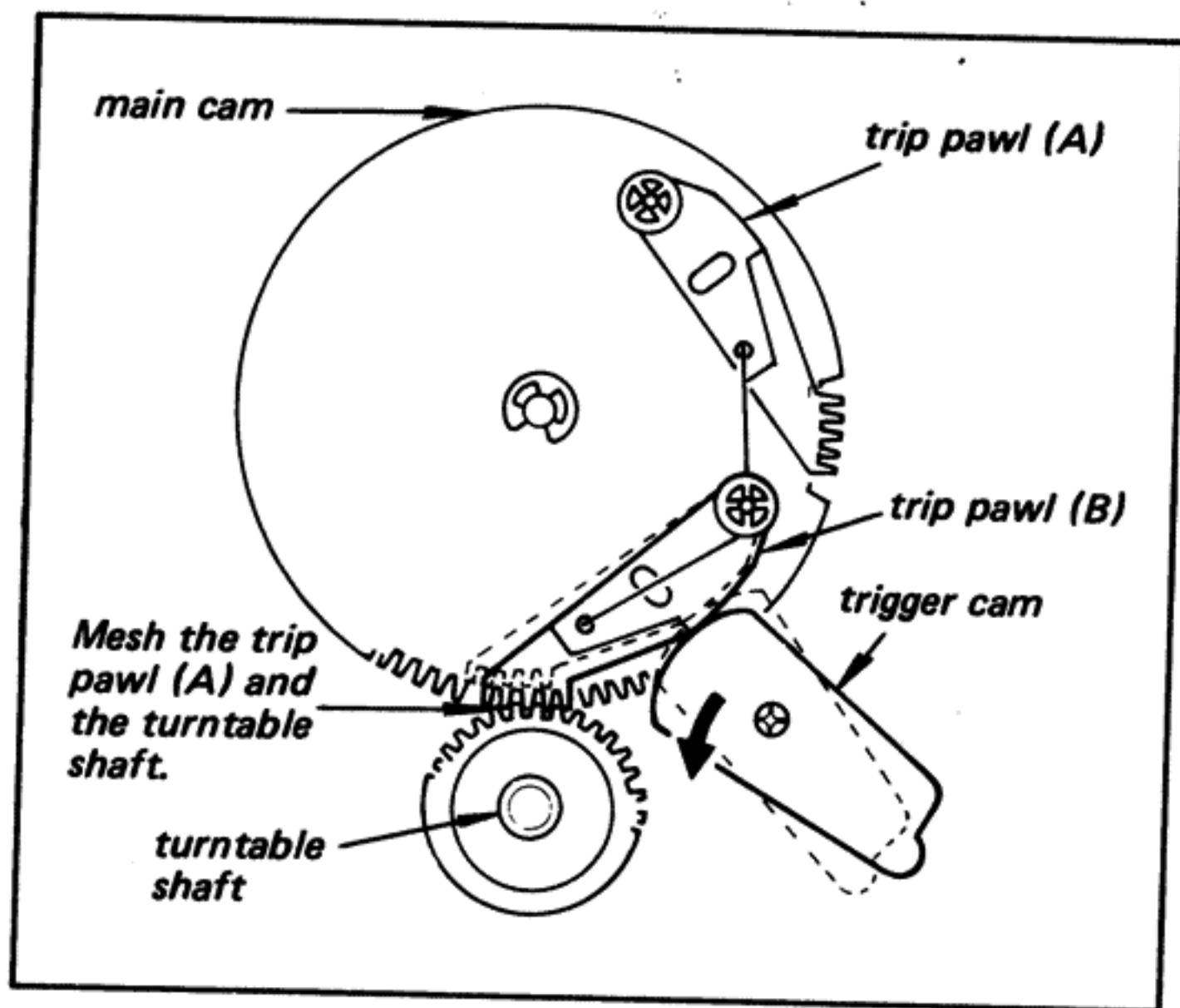
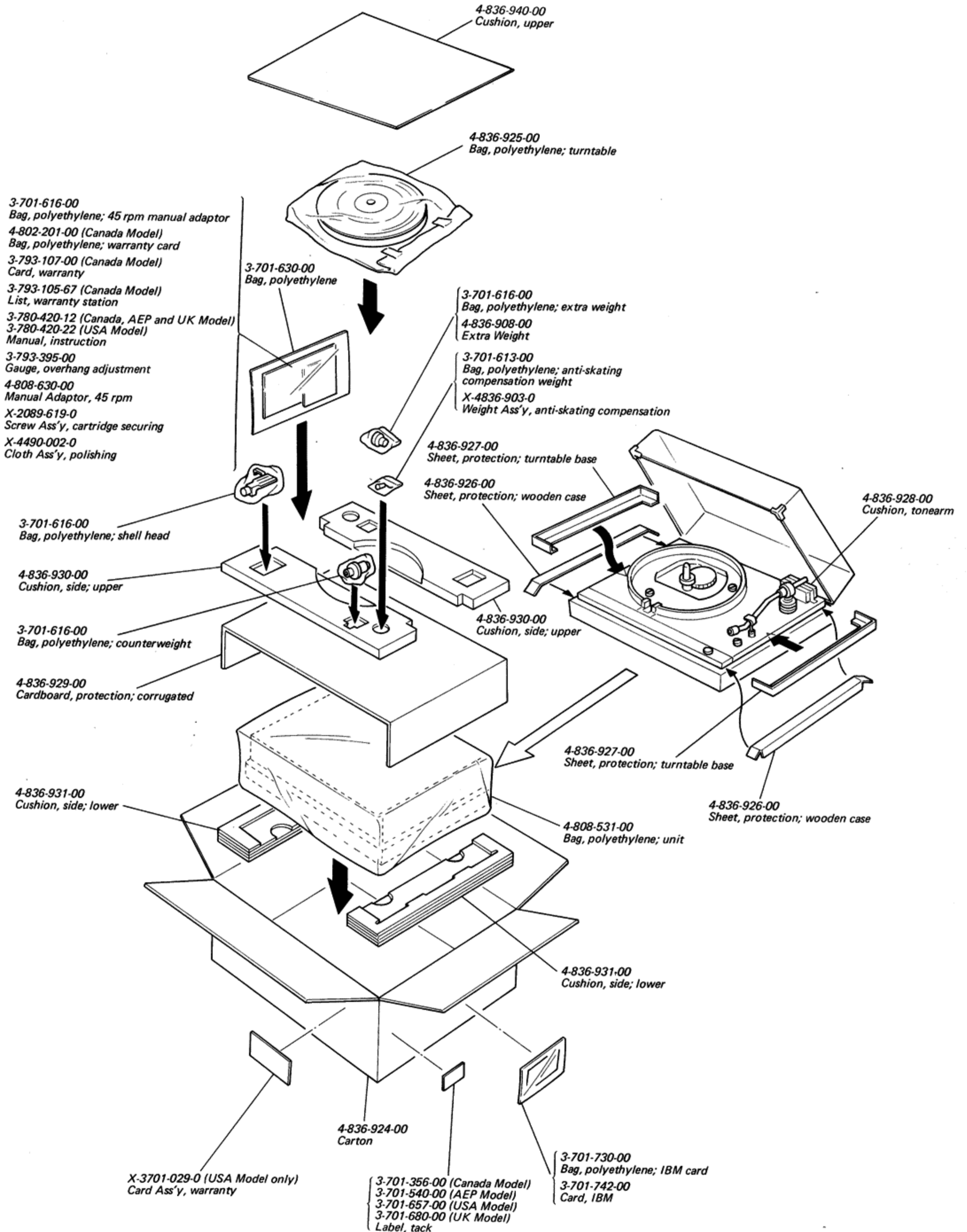

Fig. 3-16. Microswitch adjustment (3)

SECTION 4 REPACKING

The original shipping carton and packing materials are the ideal containers for shipping the unit. For the maximum protection, the unit must be

repacked in these materials precisely as before. The proper repacking procedures are shown below.



2SC1474: Q1

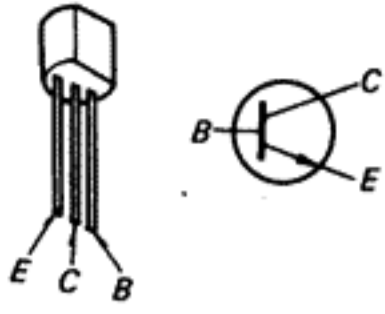

CX032B: IC1

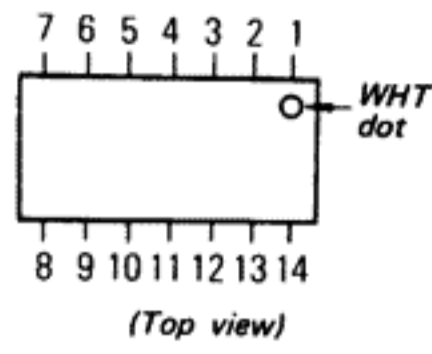

2SC945: Q2 ~ Q4

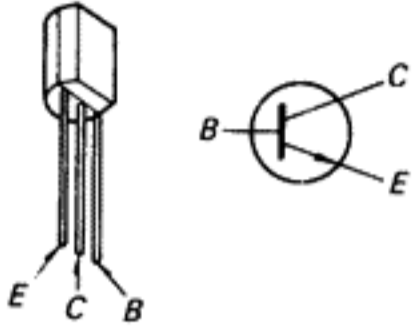

SIB01-02: D1, D4, D5, D6

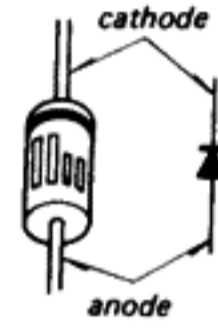

2SC1173: Q5, Q6

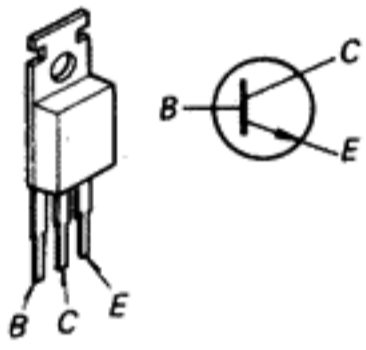

EQB01-12Z: D2



2SA733: Q7

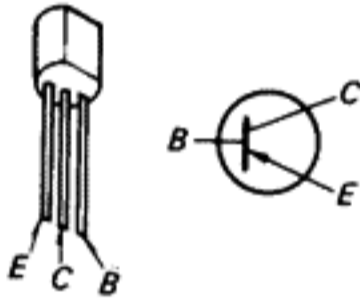

MZ12: D3

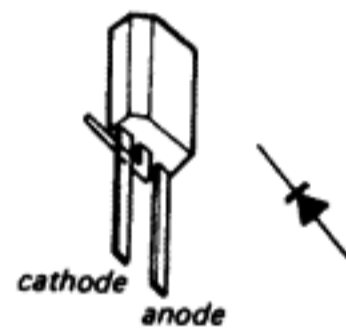

SECTION 5 DIAGRAMS

5-1. MOUNTING/WIRING DIAGRAM

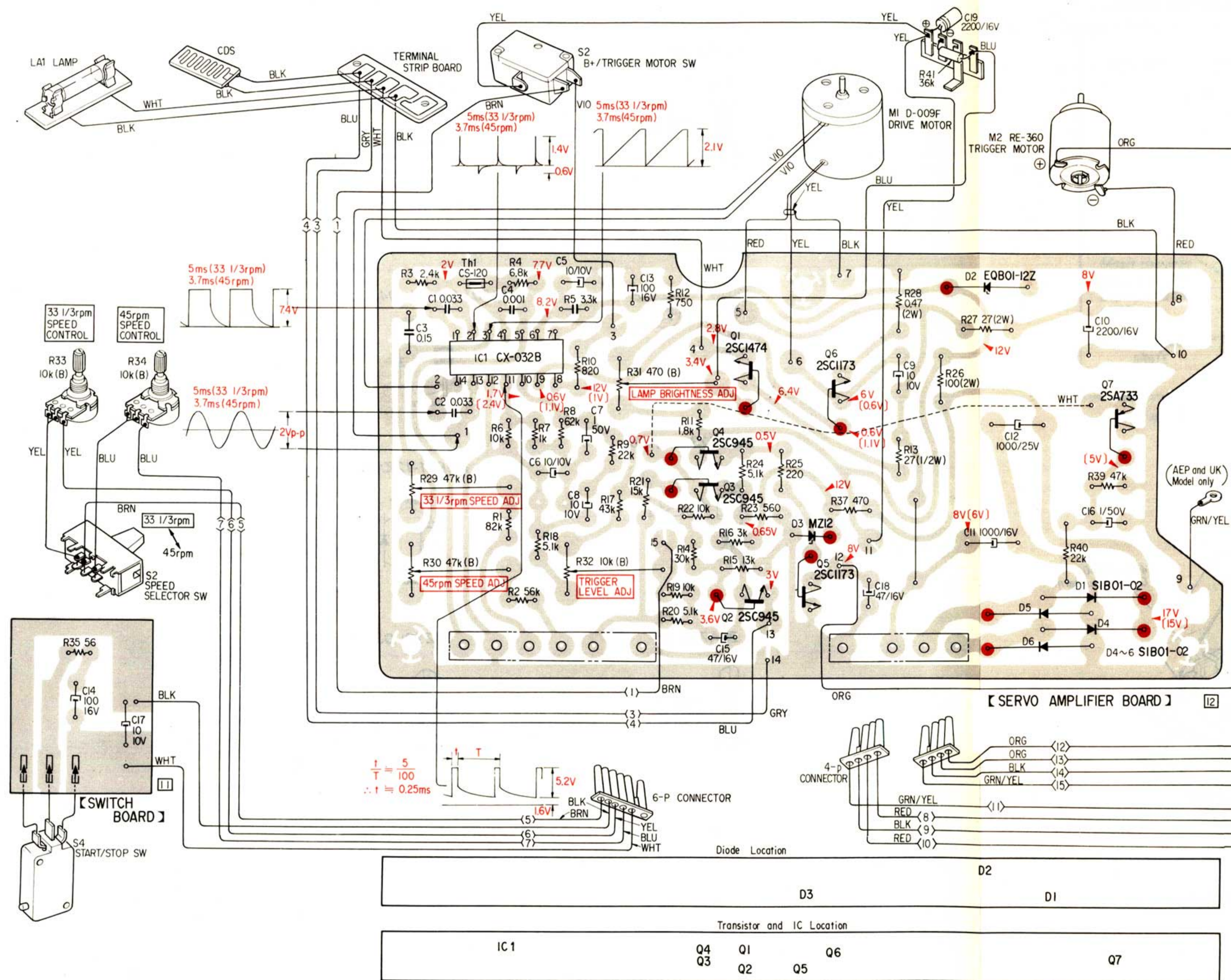

Diode Location

D1	D2	D3
----	----	----

Transistor and IC Location

IC 1	Q4	Q1	Q6
	Q3	Q2	Q5
			Q7

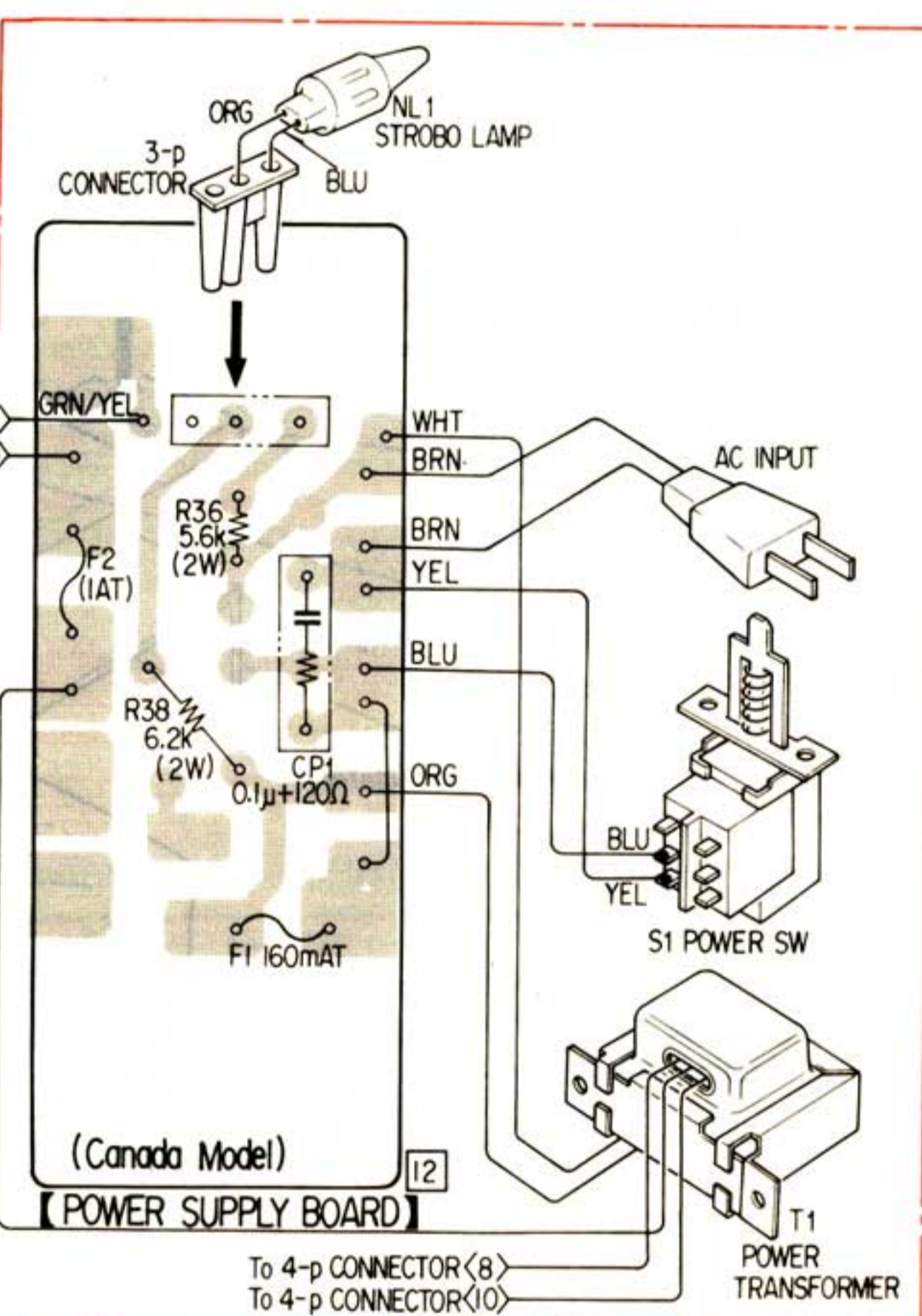
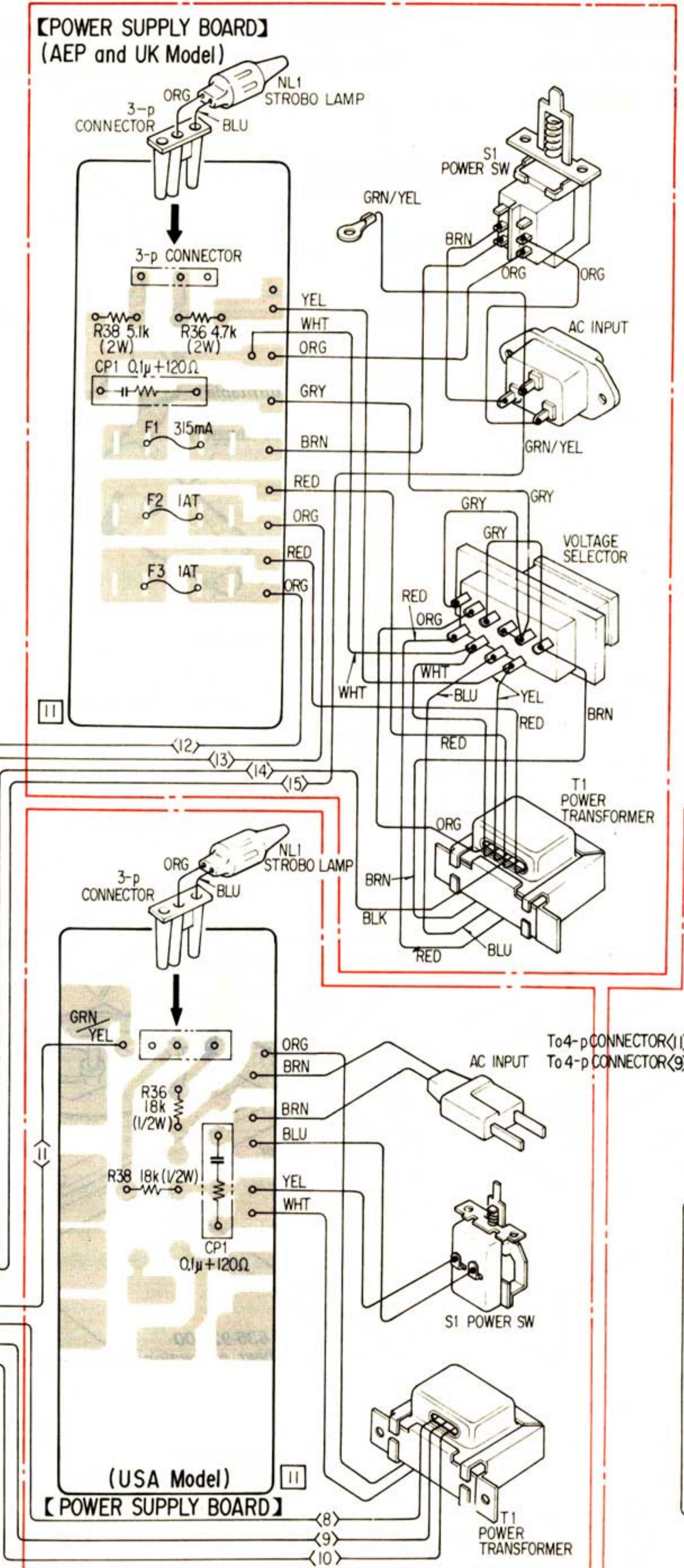

Note:

All resistance values are in ohms. k = 1000, M = 1000 k
 All capacitance values are in μF except as indicated with p, which means $\mu\mu F$.
 All voltages are dc measured with a VOM (DC 20 k ohms/V) at no signal.
 Voltage variations may be noted because of normal production tolerances.
 [] : During the motor starting period

SECTION 6

EXPLODED VIEWS

(1)

Note: 1. Parts without part numbers and names are not available.

2. All screws are Phillips type (cross recess type) unless otherwise indicated.

(-): slotted head

Hardware Nomenclature

<p>P - Pan Head Screw</p> <p>PS - Pan Head Screw with Spring Washer</p> <p>K - Flat Countersunk Head Screw</p> <p>B - Binding Head Screw</p> <p>RK - Oval Countersunk Head Screw</p> <p>T - Truss Head Screw</p> <p>R - Round Head Screw</p> <p>F - Flat Filler Head Screw</p>	<p>SC - Set Screw</p> <p>E - Retaining Ring (E Washer)</p> <p style="text-align: right;"> W - Washer SW - Spring Washer LW - Lock Washer N - Nut </p> <p>Example</p> <p>Type of Slot: P 3x10</p> <p>Length in mm (L)</p> <p>Diameter in mm (D)</p> <p>Type of Head</p>
--	--

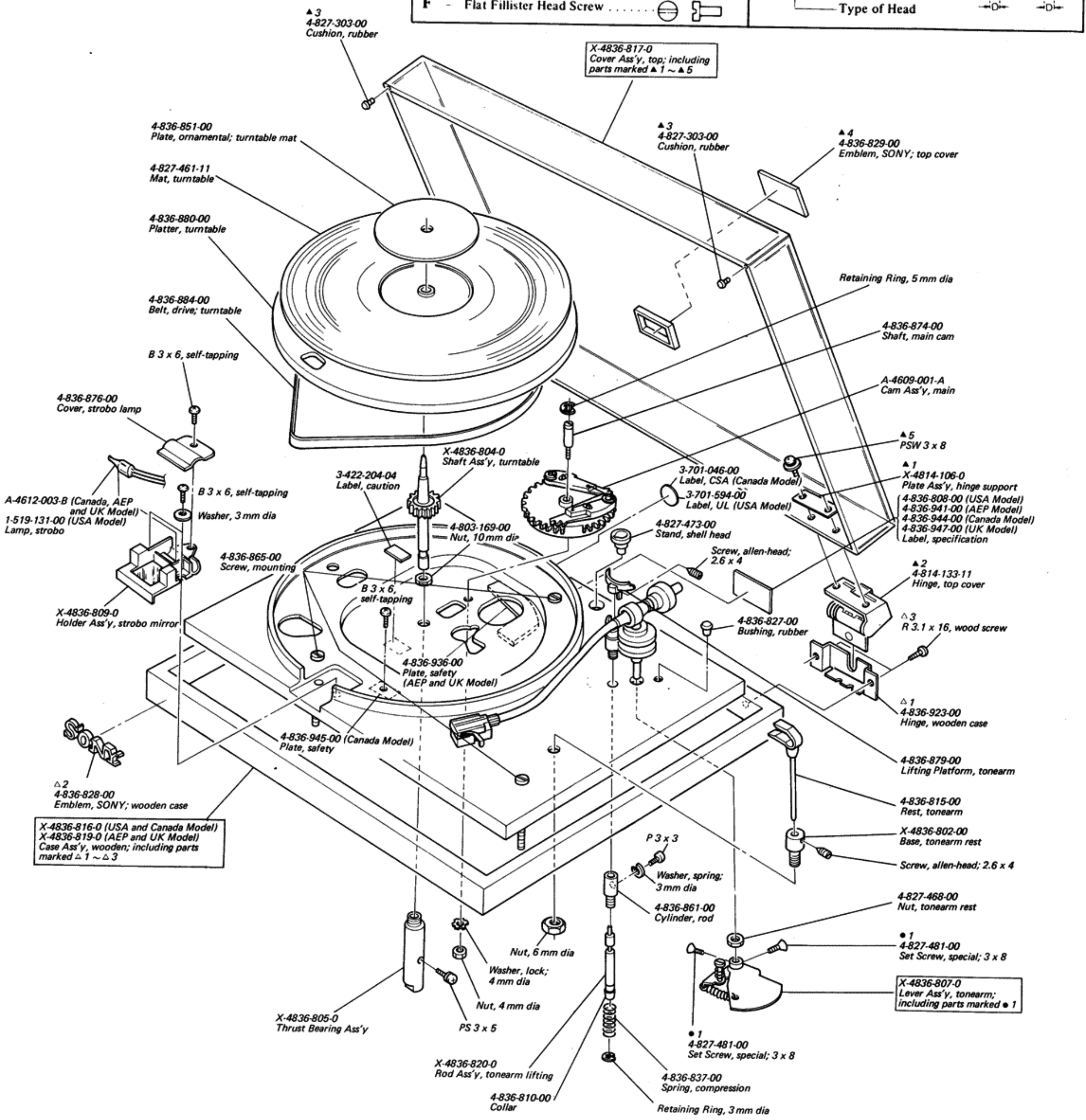

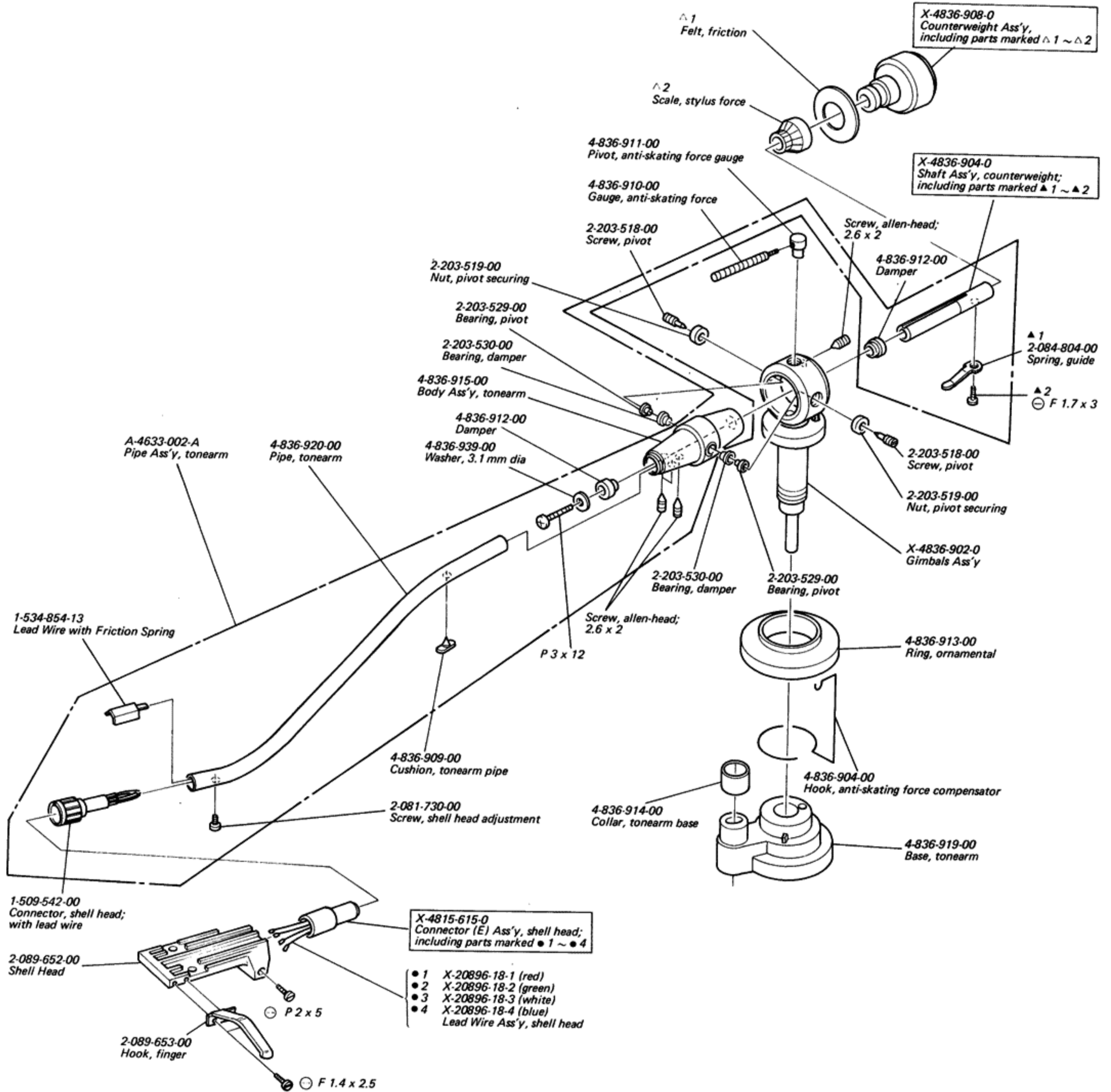

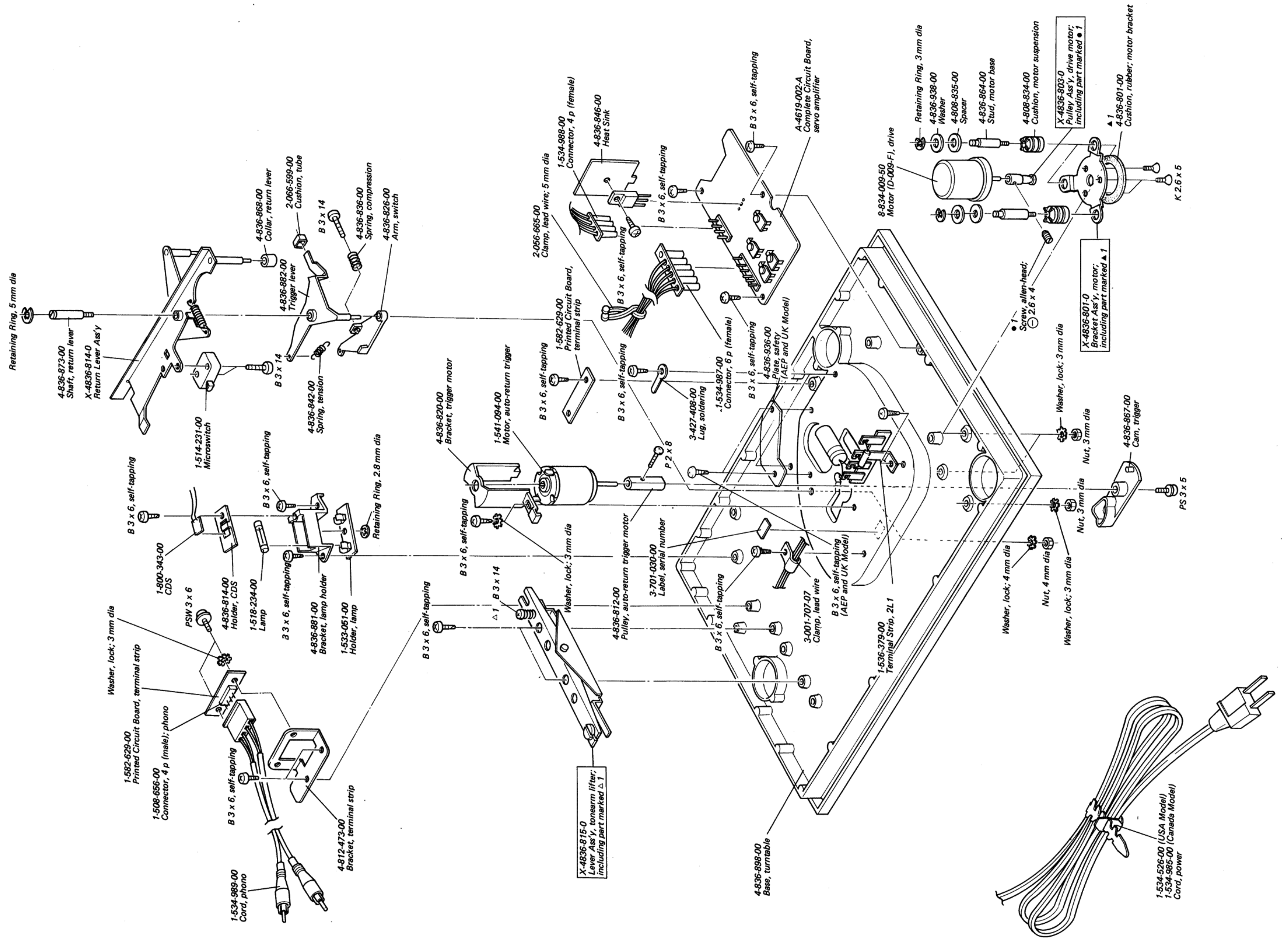

SECTION 7

ELECTRICAL PARTS LIST

<u>Ref. No.</u>	<u>Part No.</u>	<u>Description</u>
CIRCUIT BOARDS		
	A-4619-002-A	Servo Amplifier, complete
	1-582-629-00	Terminal Strip
	1-582-951-00 (USA and Canada Model)	Power Supply
	1-583-515-00 (AEP and UK Model)	
	1-583-265-00	Switch

SEMICONDUCTORS			
Q1		Transistor	2SC1474
Q2 ~ Q4		Transistor	2SC945
Q5		Transistor	2SC1173
Q6		Transistor	2SC1173
Q7		Transistor	2SA733
IC1		IC	CX-032B
D1, D4, D5, D6		Diode	SIB01-02
D2		Diode	EQB01-12Z
D3		Diode	MZ12
Th1	1-800-192-00	Thermistor	CS-120

CAPACITORS					
Capacitors listed here are electrolytic type unless otherwise specified and in μ F.					
C1	1-105-679-12	0.033	$\pm 10\%$	50 V	mylar
C2	1-105-679-12	0.033	$\pm 10\%$	50 V	mylar
C3	1-105-687-12	0.15	$\pm 10\%$	50 V	mylar
C4	1-105-661-12	0.001	$\pm 10\%$	50 V	mylar
C5	1-121-469-11	10		10 V	
C6	1-121-469-11	10		10 V	
C7	1-121-391-11	1		50 V	
C8	1-121-469-11	10		10 V	
C9	1-121-469-11	10		10 V	
C10	1-123-070-11	2200		16 V	
C11	1-121-245-11	1000		16 V	
C12	1-121-657-11	1000		25 V	
C13	1-121-415-11	100		16 V	
C14	1-121-415-11	100		16 V	
C15	1-123-055-11	47		16 V	
C16	1-123-391-11	1		50 V	
C17	1-121-469-11	10		10 V	
C18	1-121-409-11	47		16 V	

<u>Ref. No.</u>	<u>Part No.</u>	<u>Description</u>
C19	1-123-070-11	2200 16 V
RESISTORS		
All resistors are in Ω , $\pm 5\%$, $\frac{1}{4}$ W and carbon type unless otherwise specified.		
R1	1-242-719-11	82 k
R2	1-242-715-11	56 k
R3	1-242-682-11	2.4 k
R4	1-242-693-11	6.8 k
R5	1-242-685-11	3.3 k
R6	1-242-697-11	10 k
R7	1-242-673-11	1 k
R8	1-242-716-11	62 k
R9	1-242-705-11	22 k
R10	1-242-671-11	820
R11	1-242-679-11	1.8 k
R12	1-242-670-11	750
R13	1-244-835-11	27 $\frac{1}{2}$ W
R14	1-242-708-11	30 k
R15	1-242-700-11	13 k
R16	1-242-684-11	3 k
R17	1-242-712-11	43 k
R18	1-242-690-11	5.1 k
R19	1-242-697-11	10 k
R20	1-242-690-11	5.1 k
R21	1-242-701-11	15 k
R22	1-242-697-11	10 k
R23	1-242-667-11	560
R24	1-242-690-11	5.1 k
R25	1-242-657-11	220
R26	1-206-640-11	100 2 W metal oxide
R27	1-206-473-11	27 2 W metal oxide
R28	1-217-153-00	0.47 2 W metal (fuse type)
R29	1-222-765-00	47 k, adjustable
R30	1-222-765-00	47 k, adjustable
R31	1-222-770-00	470, adjustable
R32	1-222-774-00	10 k, adjustable
R33	1-222-446-00	10 k (B), variable (33 rpm)
R34	1-222-446-00	10 k (B), variable (45 rpm)
R35	1-242-643-11	56

<u>Ref. No.</u>	<u>Part No.</u>	<u>Description</u>
R36	1-206-680-11	4.7 k 2W metal oxide (AEP and UK Model)
	1-206-682-11	5.6 k 2W metal oxide (Canada Model)
	1-244-903-11	18 k ½ W (USA Model)
R37	1-242-665-11	470
R38	1-206-681-11	5.1 k 2W metal oxide (AEP and UK Model)
	1-206-683-11	6.2 k 2W metal oxide (Canada Model)
	1-244-903-11	18 k ½ W (USA Model)
R39	1-242-713-11	47 k
R40	1-242-705-11	22 k
R41	1-244-710-11	36 k

SWITCHES

S1	1-514-140-00 (USA Model) 1-516-342-00 (Canada, AEP and UK Model)
S2	1-514-231-00 Microswitch (motor)
S3	1-514-459-00 Slide (SPEED)
S4	1-514-423-00 Microswitch (START/STOP)

MISCELLANEOUS

CP1	1-101-534-00 Encapsulated Component,
T1	1-442-321-00 (USA Model) 1-442-432-00 (Canada Model) 1-442-352-00 (AEP and UK Model) Transformer, power

<u>Ref. No.</u>	<u>Part No.</u>	<u>Description</u>
	1-508-656-00	Connector, 4-P (male)
	1-509-385-00	Voltage Selector (AEP and UK Model)
	1-509-547-00	Connector, ac input; 3-P (AEP and UK Model)
	1-509-542-00	Connector, shell head; with lead wire
LA1	1-518-234-00	Lamp, 6 V 100 mA
NL1	1-519-131-00 A-4612-003-B	Lamp, strobo (USA Model) Lamp, strobo (Canada, AEP and UK Model)
F1	1-532-293-11	Fuse 315 mA (AEP, UK Model)
F2, 3	1-532-078-11	Fuse 1 AT (AEP, UK Model)
F1	1-532-275-11	Fuse 160 mA (Canada Model)
F2	1-532-078-11	Fuse 1 AT (Canada Model)
	1-533-051-00	Holder, lamp
	1-534-526-00	Cord, power (USA Model only)
	1-534-985-00	Cord, power (Canada Model)
	1-534-854-13	Lead Wire with Friction Spring
	1-534-901-81	Lead Wire with Lug (AEP, UK Models only)
	1-534-987-00	Connector, 6-P (female)
	1-534-988-00	Connector, 4-P (female)
	1-534-989-00	Cord, phono
	1-536-379-00	Terminal Strip, 2L1
M2	1-541-094-00	Motor, auto-return trigger (RE-360)
M1	8-834-009-50	Motor, drive (D-009F)

STEREO TURNTABLE SYSTEM

PS-5550

US Model
Canadian Model
AEP Model
UK Model

CORRECTION

No. 1
November, 1977

File this Correction with the Service Manual.

Part Number		Description
Correct	Incorrect	
X-4836-903-0 (US, Canadian Model) X-4836-905-0 (AEP, UK Model)	X-4836-903-0	Weight Ass'y, anti-skating compensation

 : corrected portion

On page 17 of the Service Manual.

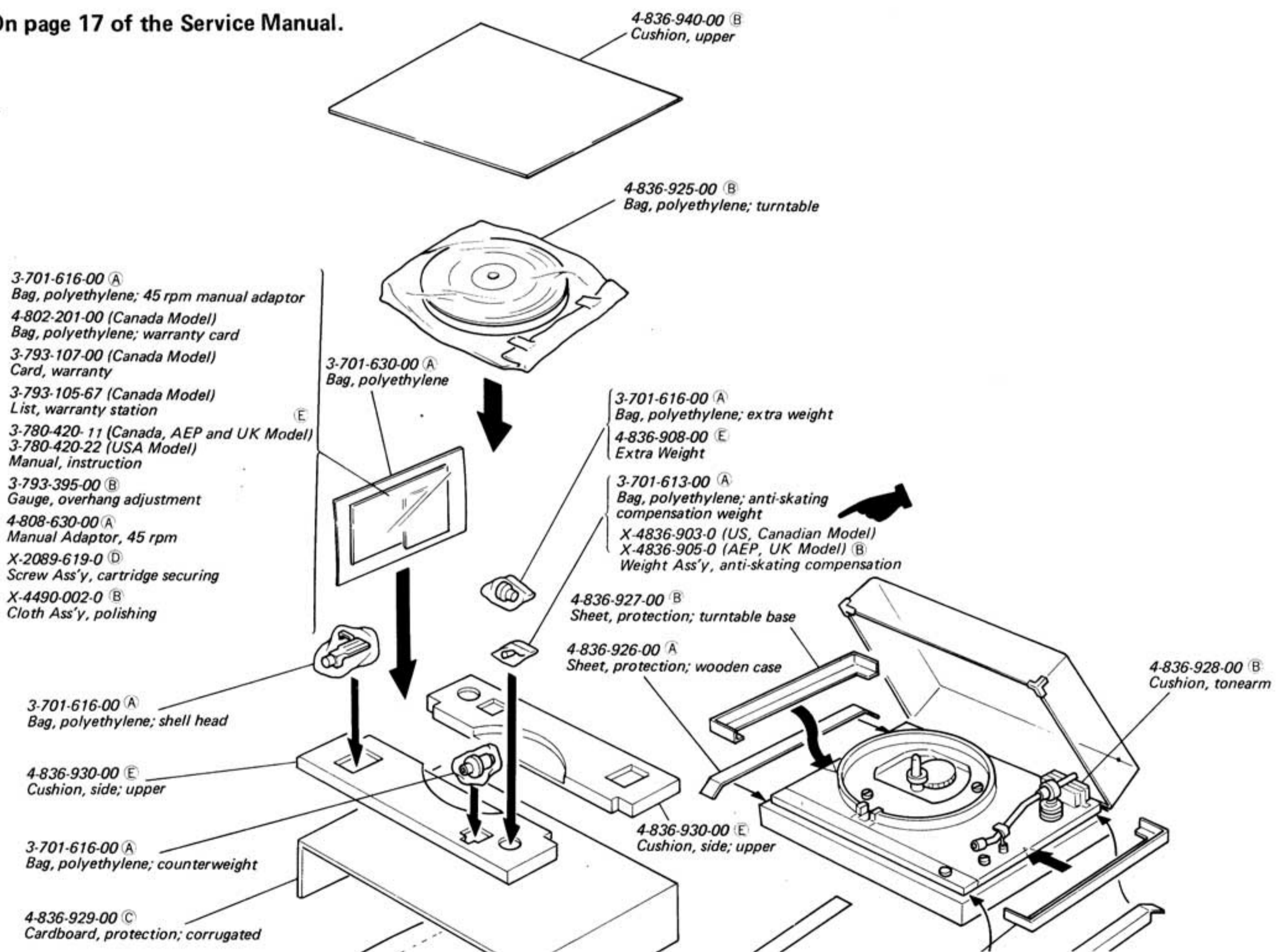

Note: Circled letters (A) to (Z) are applicable to European models only.

SONY® SERVICE MANUAL

SONY®

hi-fi Service Bulletin No. 70

SONY CORPORATION OF AMERICA
Technical Publications Department
47-47 Van Dam Street, Long Island City, New York 11101

Model: PS-5550

Subject: Transit Screws

Date: August 18, 1978

Transit screws with a stepped thread (see photo below) are currently supplied instead of the original style (constant-diameter thread). The part number for the new screws is the same as the old (4-836-865-00). The new screws require a special nut (not supplied with screw orders) to properly utilize them in the PS-5550. Order a number 4-836-946-01 nut for each transit screw ordered.

