

# PS-FL5/FL5C



PS-FL5:

*AEP Model*

*UK Model*

*US Model*

*Canadian Model*

*E Model*

PS-FL5C:

*US Model*

## STEREO TURNTABLE SYSTEM

### SPECIFICATIONS

<b>Turntable</b>	
Platter	30 cm (11 $\frac{7}{8}$ in.), aluminum-alloy diecast
Motor	Linear torque BSL (brushless and slotless) motor
Drive system	Direct drive
Control system	Quartz lock control, magnedisc servo control system

Speed	33 $\frac{1}{3}$ rpm, 45 rpm
Starting characteristics	Comes to nominal speed within a half revolution (33 $\frac{1}{3}$ rpm)
Wow and flutter	0.02% (WRMS)* 0.025% (WRMS) $\pm 0.04\%$ (DIN)
Signal-to-noise ratio	78 dB (DIN-B)
Load characteristics	0% up to 100g stylus force (at lead-in groove of a record)
Speed deviation	Within $\pm 0.003\%$
Automatic system	Lead-in, return, reject, repeat, record size selection

#### Tonearm

Type	Statically balanced
Pivot-to-stylus length	216.5 mm (8 $\frac{1}{2}$ in.)
Overall arm length	300 mm (11 $\frac{7}{8}$ in.)
Overhang	16.5 mm (2 $\frac{1}{32}$ in.)
Tracking error	+3°, -1°
Stylus force adjustment range	0-2.5g
Cartridge shell weight	5g
Cartridge weight range (including supplied cartridge shell)	
PS-FL5:	7.5-11.5g
PS-FL5C:	7.5-12g

#### SAFETY-RELATED COMPONENT WARNING!!

COMPONENTS IDENTIFIED BY SHADING AND MARK  ON THE SCHEMATIC DIAGRAMS, EXPLODED VIEWS AND IN THE PARTS LIST ARE CRITICAL TO SAFE OPERATION. REPLACE THESE COMPONENTS WITH SONY PARTS WHOSE PART NUMBERS APPEAR AS SHOWN IN THIS MANUAL OR IN SUPPLEMENTS PUBLISHED BY SONY.

#### ATTENTION AU COMPOSANT AYANT RAPPORT À LA SÉCURITÉ!

LES COMPOSANTS IDENTIFIÉS PAR UNE TRAME ET UNE MARQUE  SUR LES DIAGRAMMES SCHEMATIQUES, LES VUES EXPLOSÉES ET LA LISTE DES PIÈCES SONT CRITIQUES POUR LA SÉCURITÉ DE FONCTIONNEMENT. NE REMPLACER CES COMPOSANTS QUE PAR DES PIÈCES SONY DONT LES NUMÉROS SONT DONNÉS DANS CE MANUEL OU DANS LES SUPPLÉMENTS PUBLIÉS PAR SONY.



— Continued on page 2 —

# SONY<sup>®</sup>

## SERVICE MANUAL

# PS-FL5/FL5C

**Cartridge XL-20 (Supplied only with E model.)**  
 Type Moving magnet type  
 Frequency response 10 Hz to 30 kHz  
 Channel separation 25 dB at 1 kHz  
 Output voltage 3 mV at 1 kHz, 5 cm/sec., 45°  
 Load impedance 50 to 100 kilohms  
 Tracking force 1.0 to 2.0 g (1.5 g recommended)  
 Stylus Sony ND-200E  
 Weight 3.4 g

**Cartridge VL-5 (Supplied only with the PS-FL5C)**  
 Type Moving magnet type  
 Frequency response 10 Hz to 20 kHz  
 Channel separation 20 dB at 1 kHz  
 Output voltage 3.5 mV at 1 kHz, 5 cm/sec., 45°  
 Load impedance 47 to 100 kilohms  
 Tracking force 1.5 to 2.5 g (2 g recommended)  
 Stylus Sony ND-5G (conical 0.6 mil diamond)  
 Weight 4.9 g

**General**  
 Power requirements AEP model: 220 V ac, 50/60 Hz  
 UK model: 240 V ac, 50/60 Hz  
 E model: 110–120 or 220–240 V ac adjustable 50/60 Hz  
 US, Canadian model, PS-FL5C: 120 V ac, 60 Hz  
 Power consumption 10 W  
 Dimensions Approx. 430 x 107 x 385 mm (w/h/d) (17 x 4¼ x 15¼ in.) including projecting parts and controls  
 Weight Approx. 10.8 kg (23 lbs 13 oz), net  
 Approx. 12.7 kg (28 lbs), in shipping carton

\* This new measuring method concerns only the turntable assembly, including the platter. It excludes wow and flutter caused by the tonearm, the cartridge, or the record. Measured by obtaining signal from magnetic pick-up head.

— Specification Label —

## MODEL IDENTIFICATION

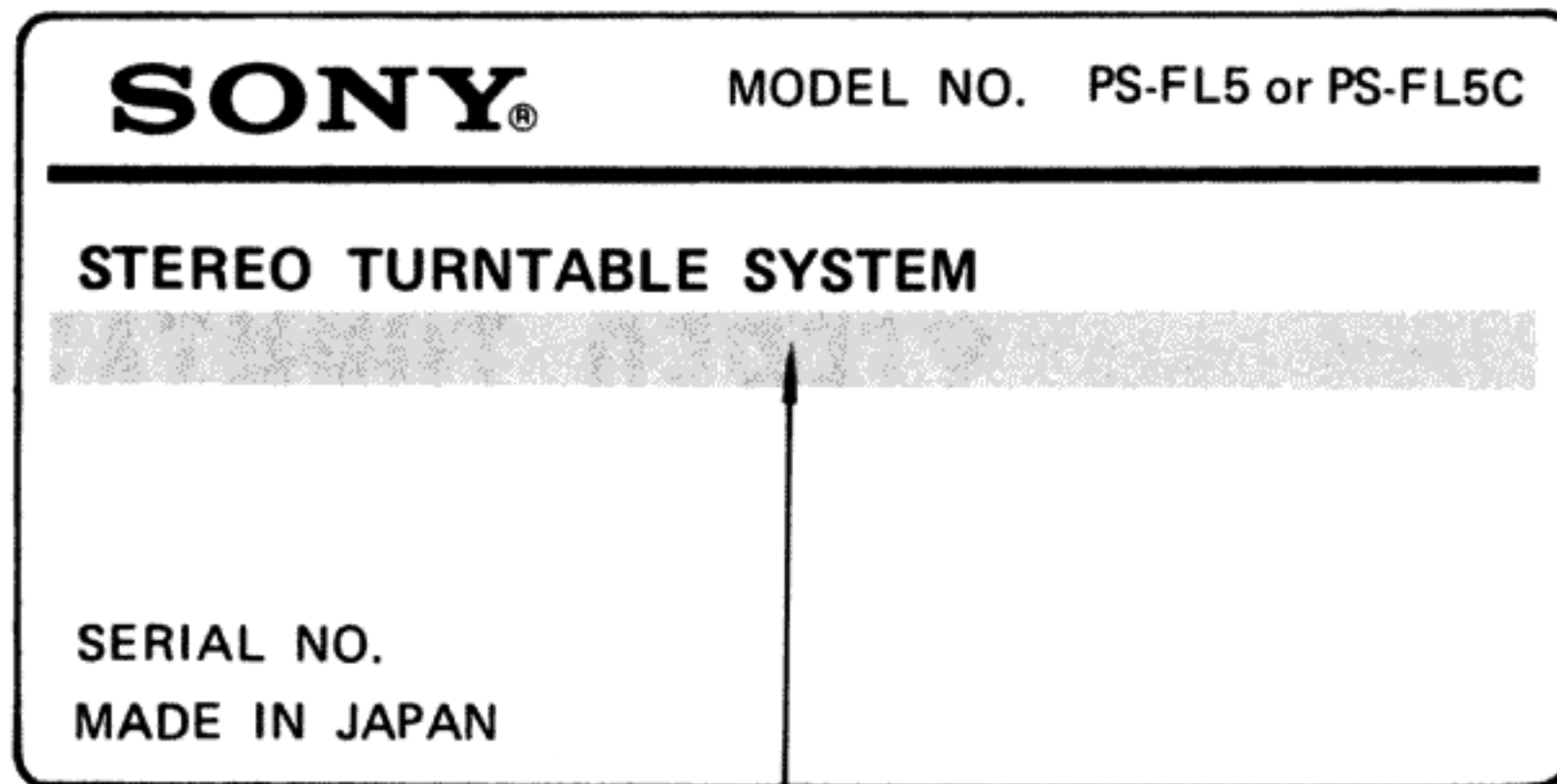

**PS-FL5:**  
 US, Canadian model: AC 120 V 60 Hz 10 W  
 AEP model: AC 220 V ~ 50/60 Hz 10 W  
 E model: AC 110 – 120 V, 220 – 240 V ~ 50/60 Hz 10 W  
 UK model: AC 240 V ~ 50/60 Hz 10 W  
**PS-EL5C:** AC 120 V 60 Hz 10 W

— Power Cord —

E1 Model  
 Euro-plug  
 1-555-734-00

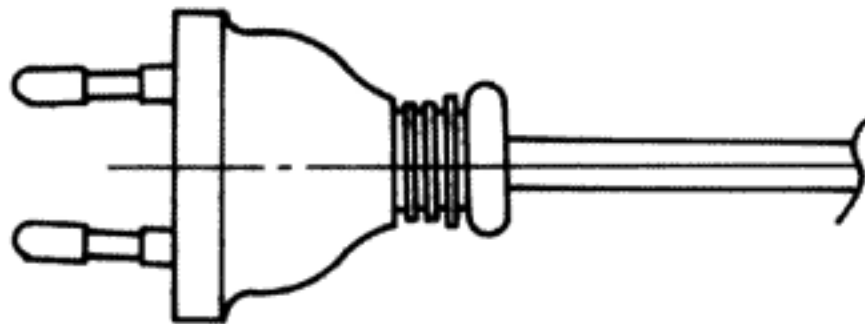

E2 Model  
 Parallel-blade plug  
 1-551-472-00





**Handling Precautions for MOS ICs**

Generally, the insulation resistance of the oxide layer in MOS IC structures is very high, and the oxide layer is very thin. Because of this, it is possible that the static voltages usually present on clothes and the human body will be enough to generate a potential difference across the insulator, high enough to cause a breakdown of the insulating layer.

The following precautions should be taken while handling these ICs.

(Particular care should be taken under conditions of low humidity.)

**Precautions in Replacing MOS ICs**

1. Store new ICs by inserting them into a urethane-polyester cushion (which is somewhat conductive), or wrapping it in aluminum foil, so that all the pins are at the same potential. (The ICs should be stored in that manner until mounted on the circuit board.)

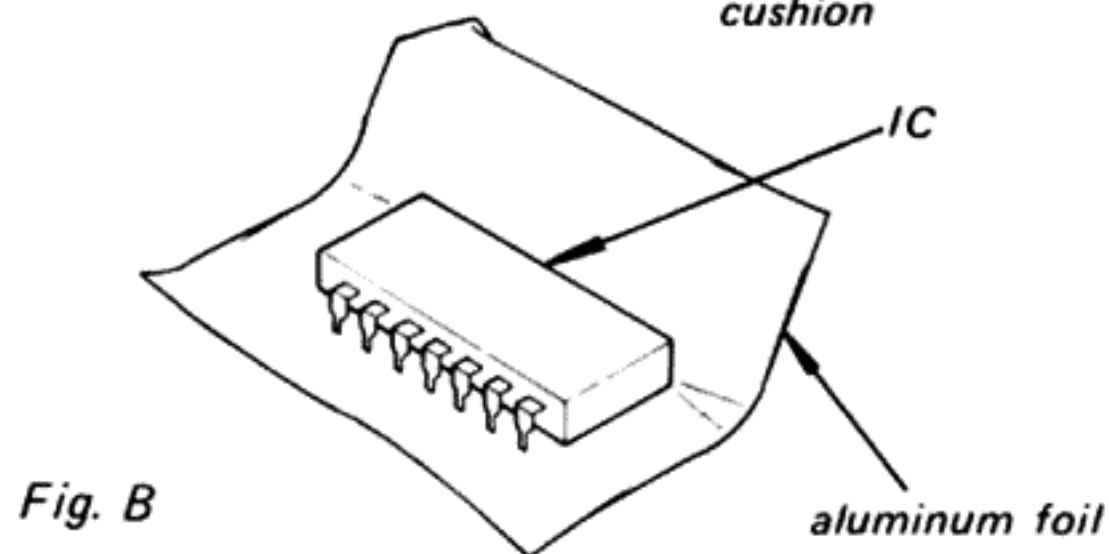
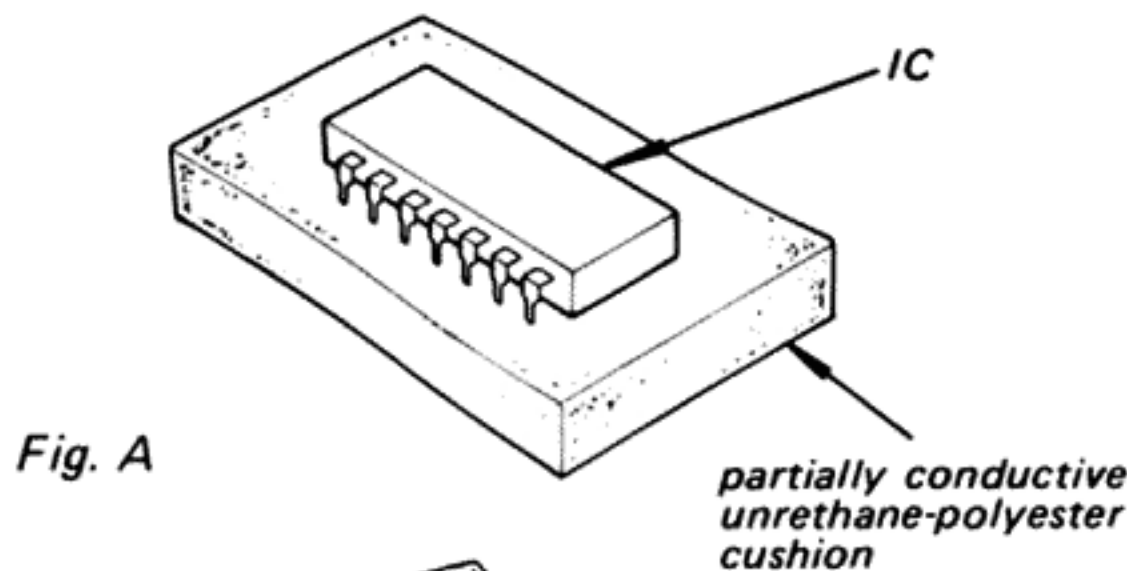

2. Check the soldering iron for possible power-line leakage current. Make sure that there is no leakage path by connecting an ohmmeter to the tip of the soldering iron and the plug as shown in Fig. C. If there is a leakage path, use some other soldering iron.

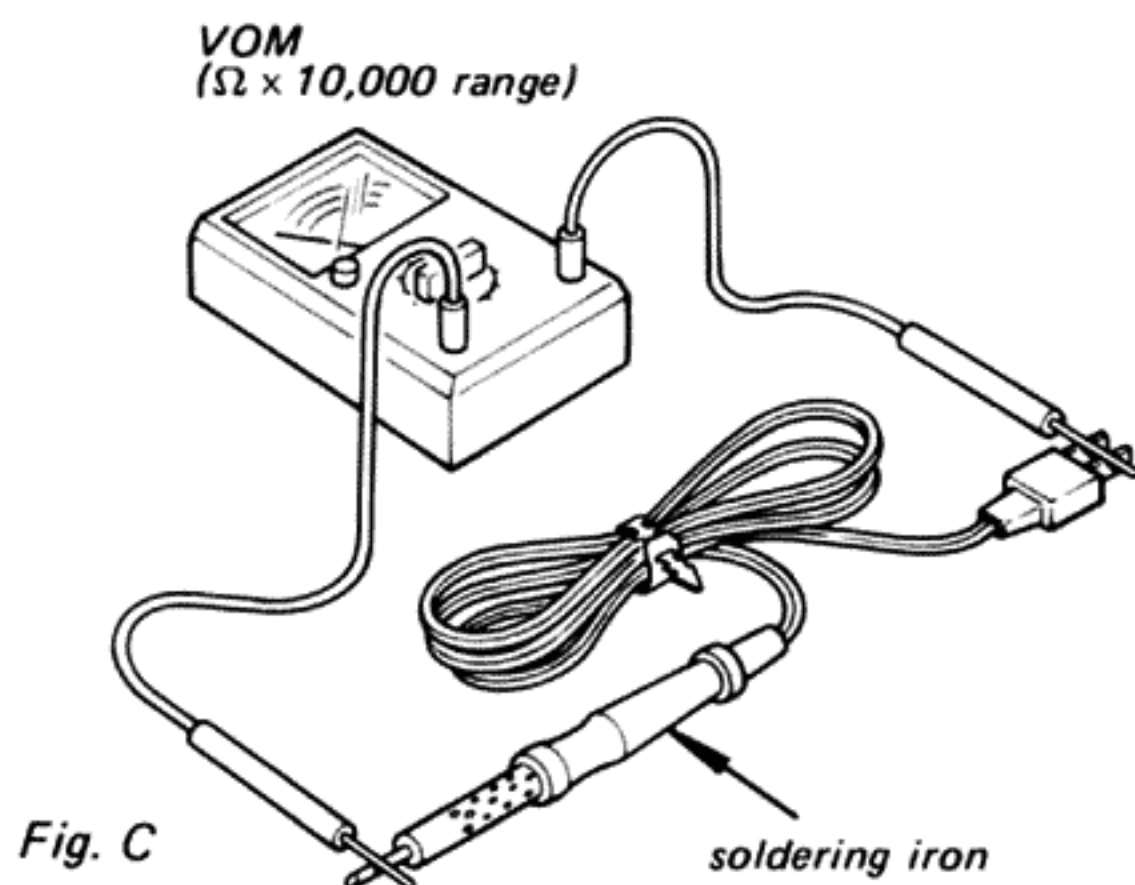

3. Equalize any potential difference between the clothes, the tools in use, the work bench, the set being worked on, and the packaged IC by touching them all in succession with the hands or a conductive wire or tool.
4. The following are effective methods for handling ICs that remove the potential difference across the oxide layer.
  - Use a paper clip modified by soldering in a wire braid insert.

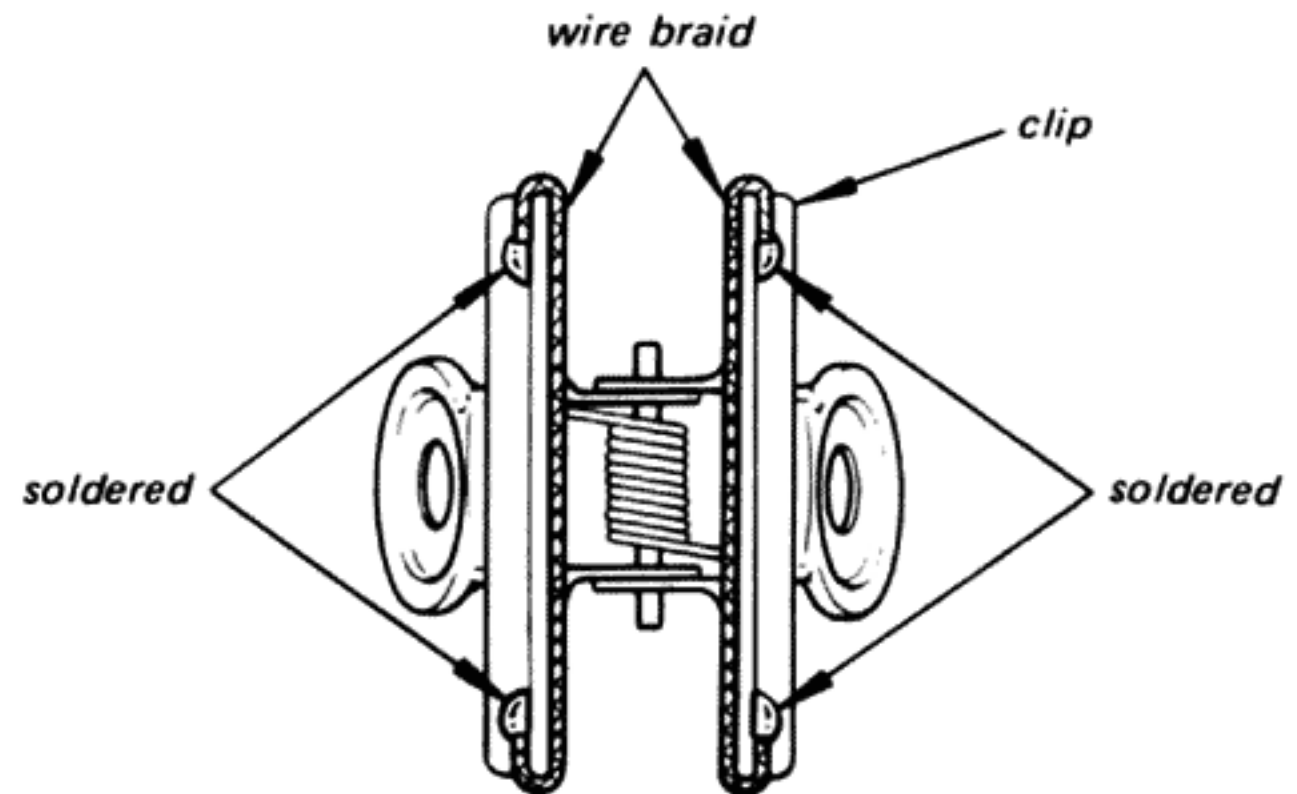

Make sure that there is no solder on the inside.

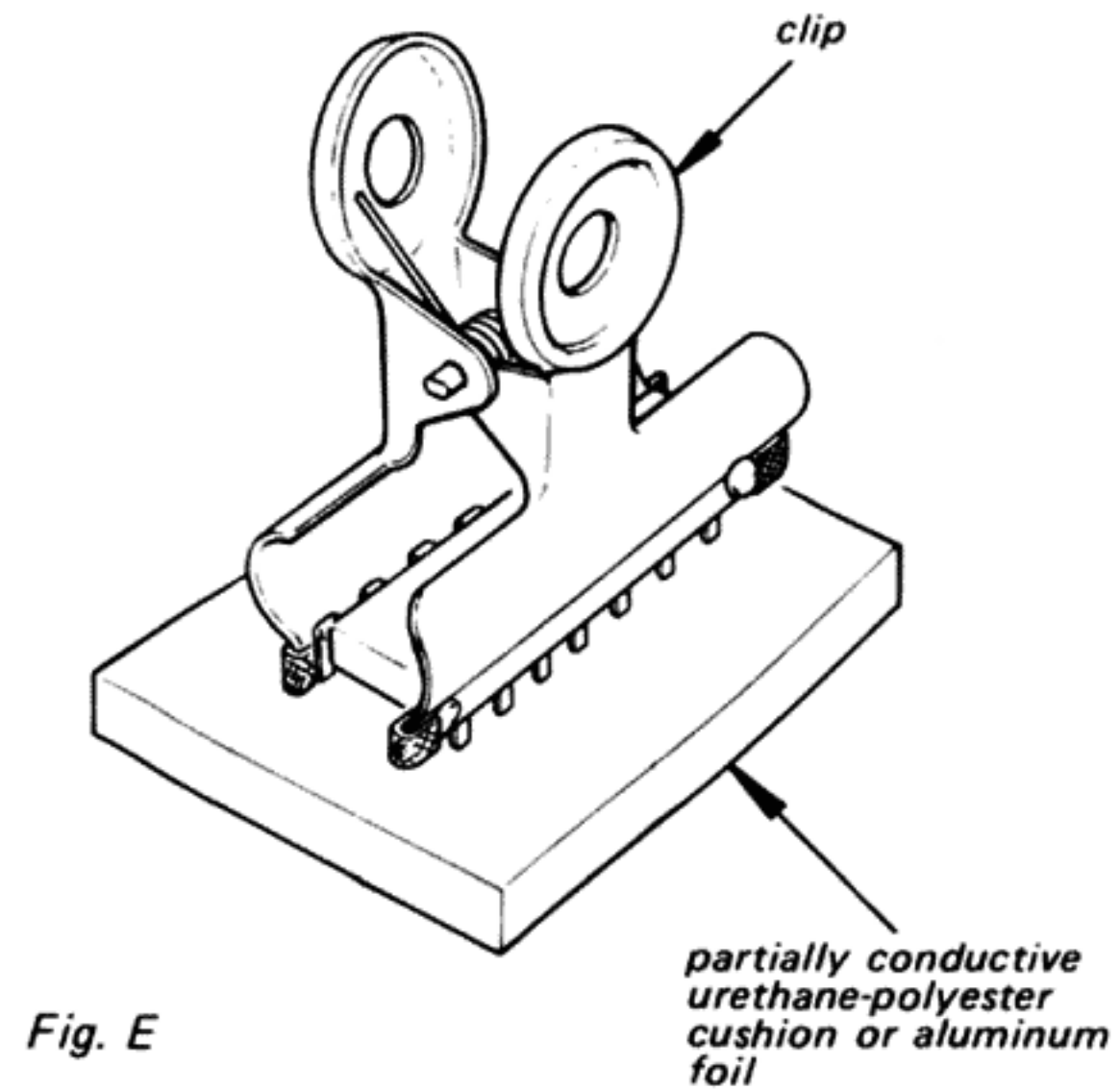
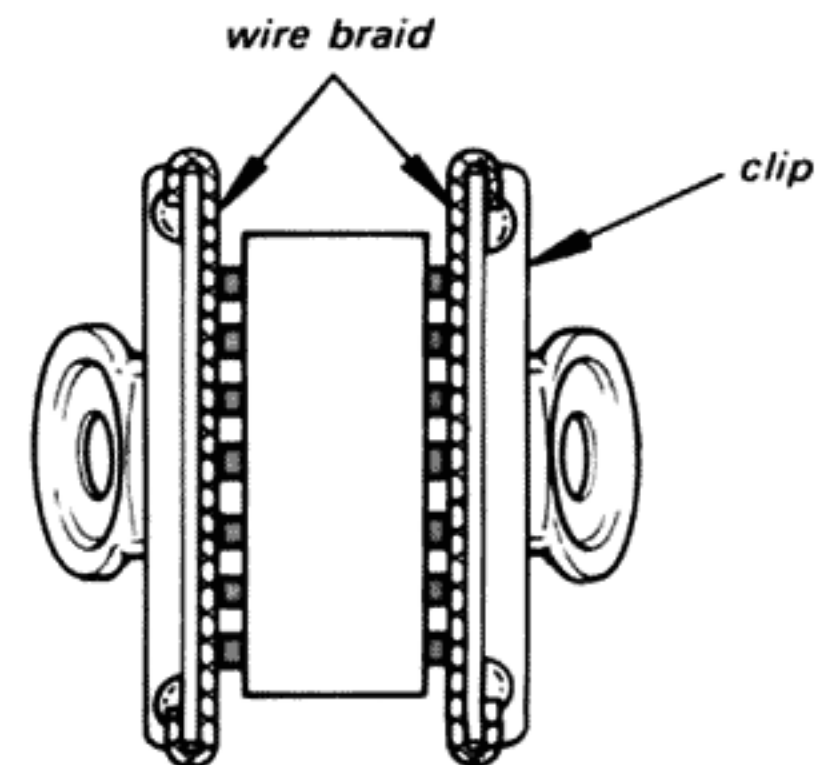

Fig. E



Make sure that all the pins are in contact with the wire braid (all the pins will then be at the same potential.).

Fig. F

- Take a short length of fine bare wire and wind it around the IC so that it shorts all the pins of the IC, while it is still in the urethane-polyester cushion or aluminum foil. This ensures that all the pins are at the same potential.

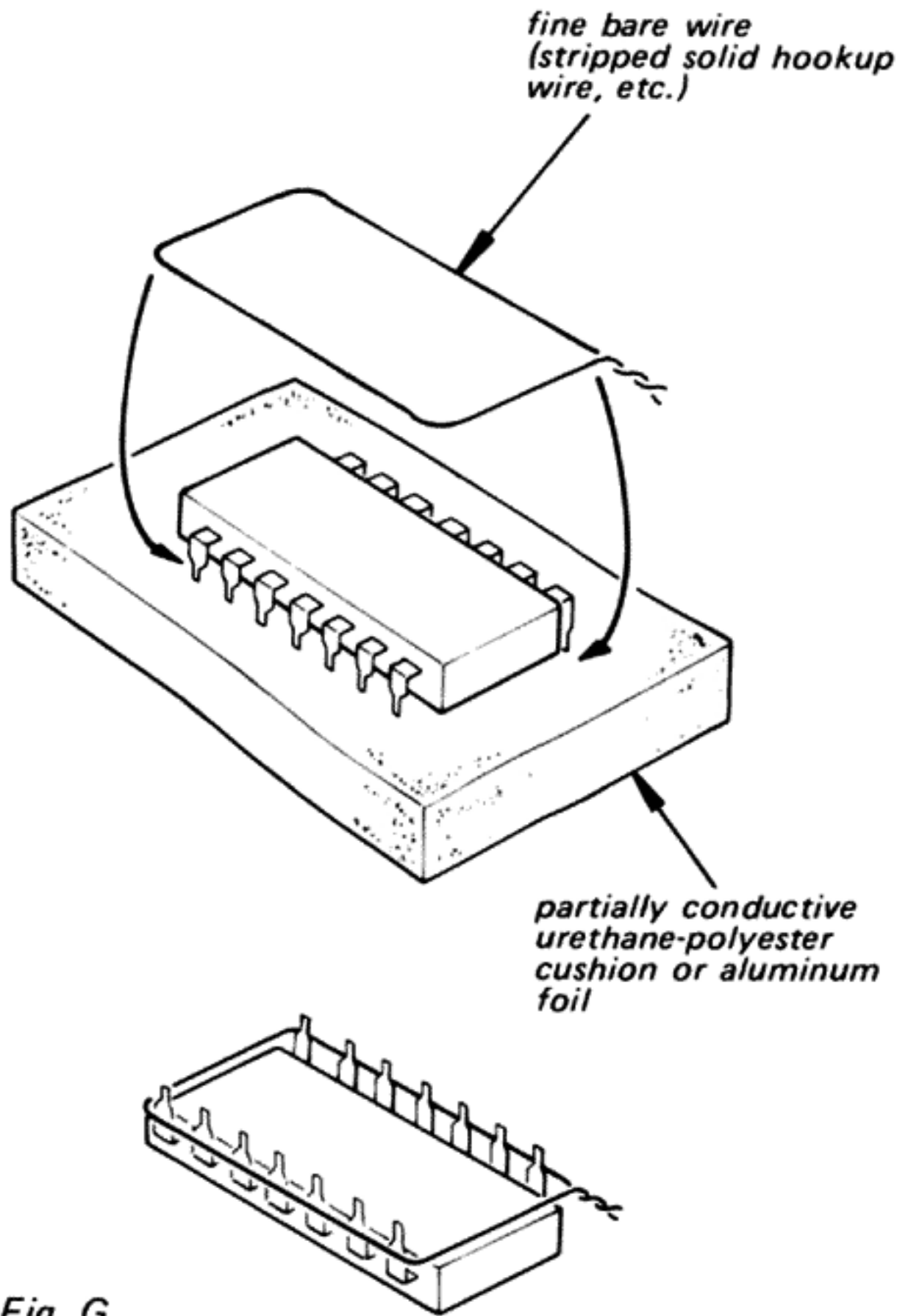

Fig. G

- When it is necessary to handle the IC with the fingers, do not touch any pin, and hold the IC at the ends of its plastic-package case as shown in Fig. H.

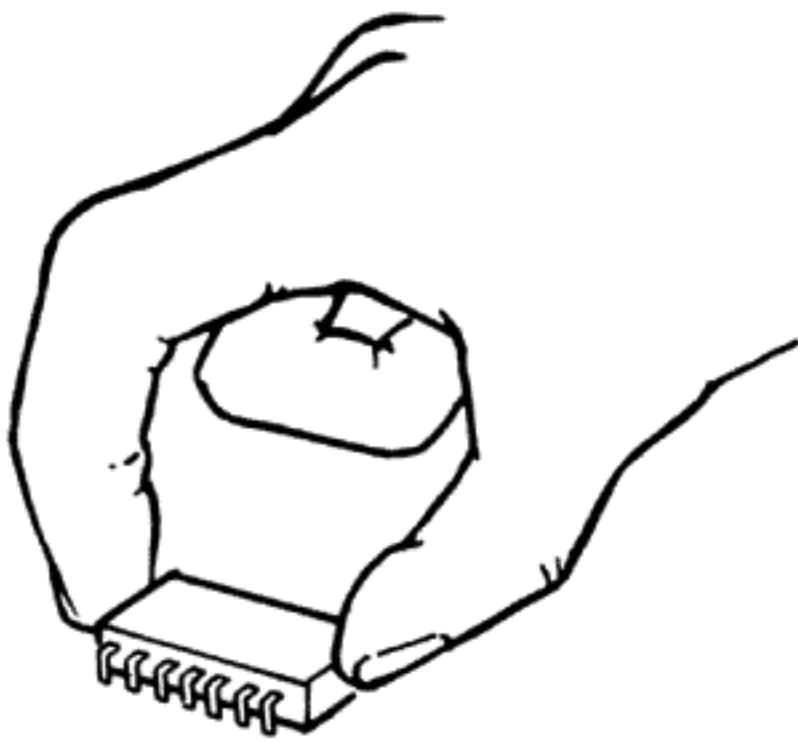

Fig. H

## 5. Method of Mounting

Insert the IC while holding it with the modified clip, and solder all the pins with the clip still shorting the pins. (Similarly, solder all the pins while the bare shorting wire is still wound around them.). Remove the clip or the bare shorting wire only after all the pins have been soldered.

## Precaution while Checking C-MOS ICs

The C-MOS ICs (Complementary MOS) are MOS ICs that have their output sections made up of N-channel and P-channel push-pull stages to increase their speed of operation. If the output terminal of these ICs comes into contact with B+ or B- voltage, then the FET which is ON at that time will either become shorted or open.

This is valid for all the output sections that are connected together by the interconnections. Even the circuits that are physically separated (and not on the same board) can be destroyed simultaneously.

### Example:

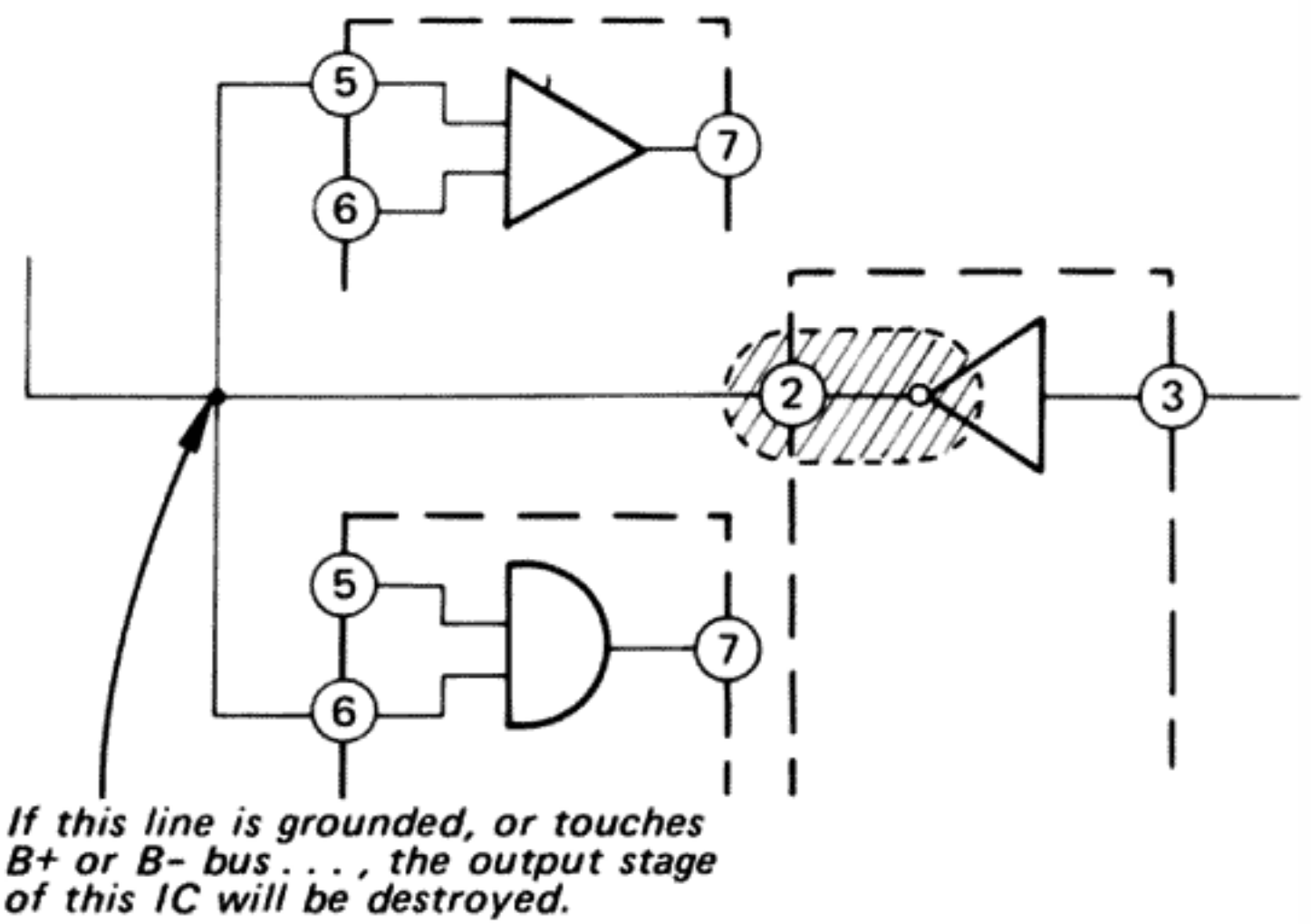
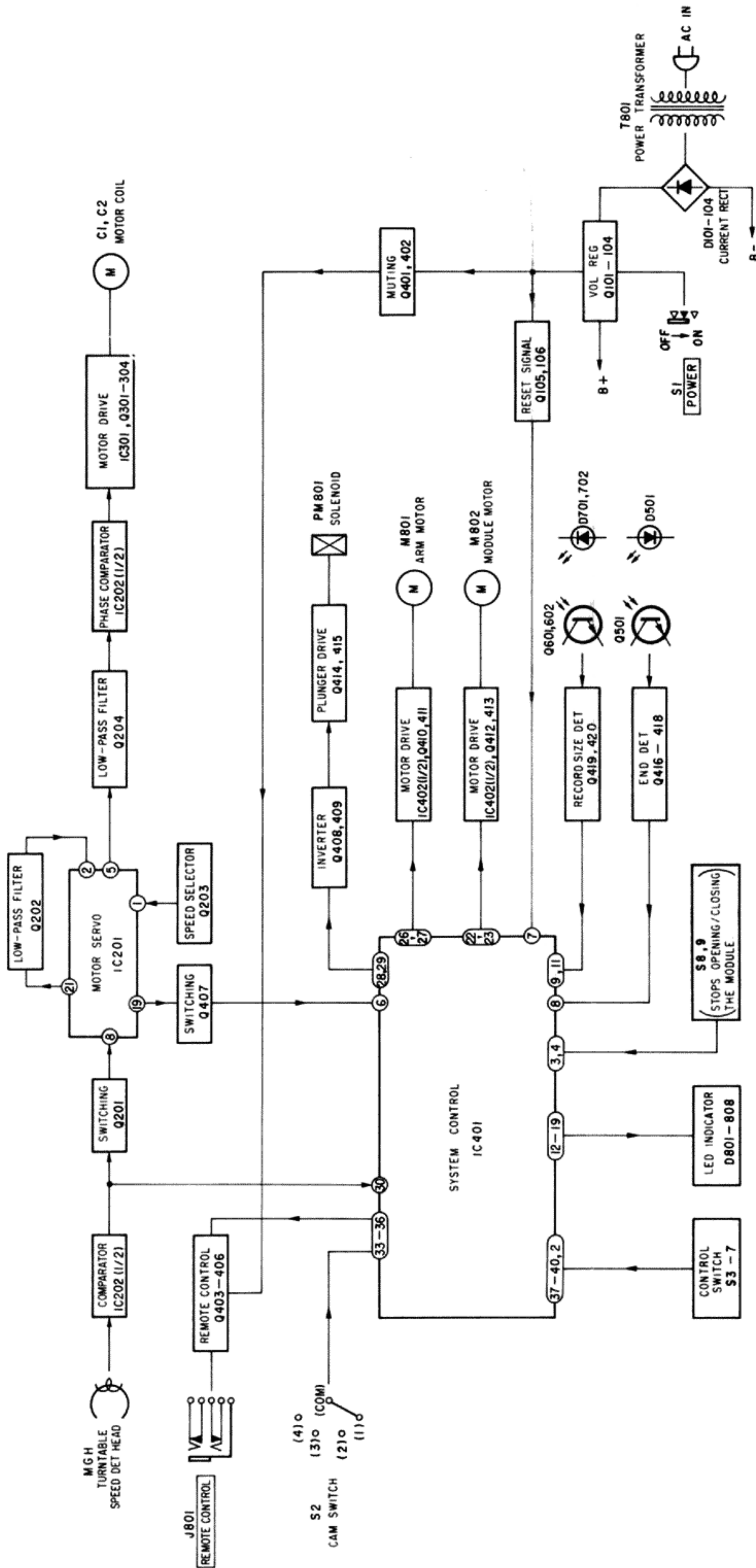

Fig. I

SECTION 1  
OUTLINE

1-1. BLOCK DIAGRAM



## 1-2. OUTLINE TURNTABLE ASSEMBLY

① Remove the transit screws with red heads. Save these screws and screw guides, since they will be required when repacking.

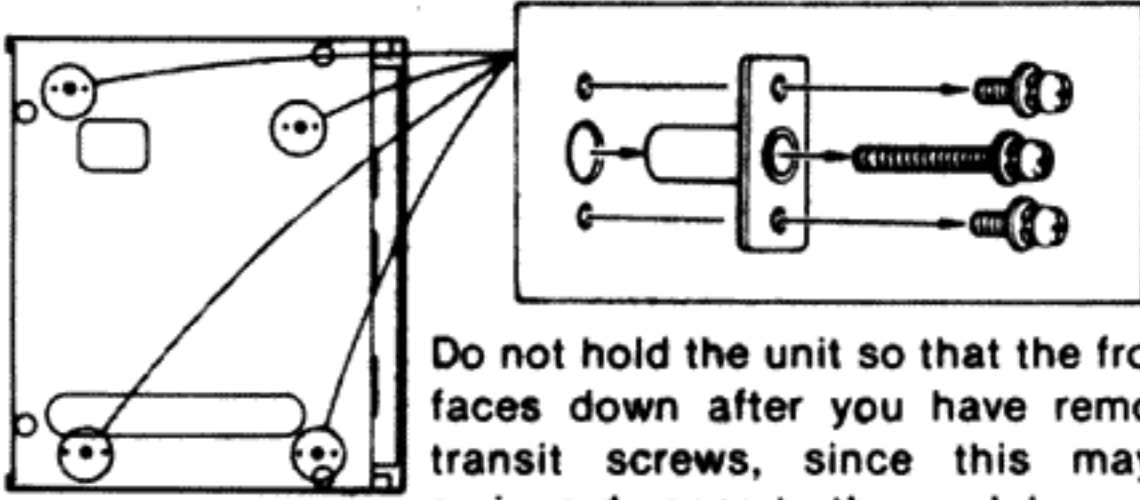

Do not hold the unit so that the front panel faces down after you have removed the transit screws, since this may cause serious damage to the module.



Remove all packing material and wipe the cabinet off. Save the packing box and materials for possible future use.

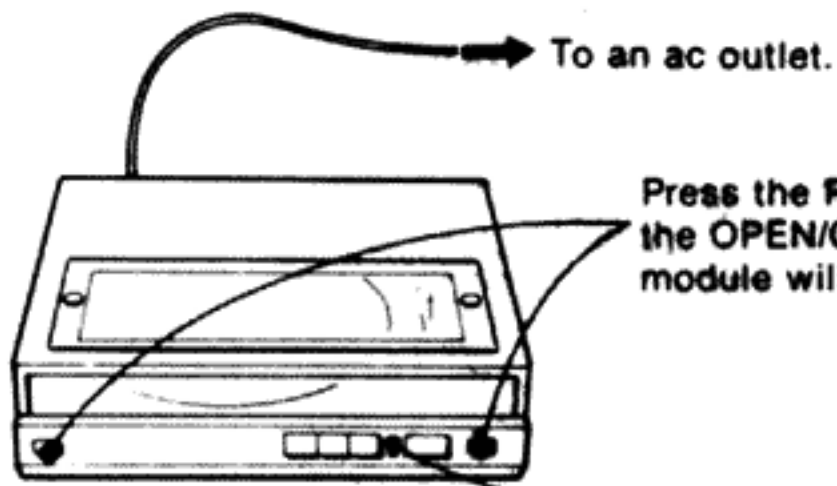

Press the **POWER** button and press the **OPEN/CLOSE** button. The module will open.

While the tonearm operation indicator is flickering, the **OPEN/CLOSE** button will not operate. Press it again when the indicator goes out.

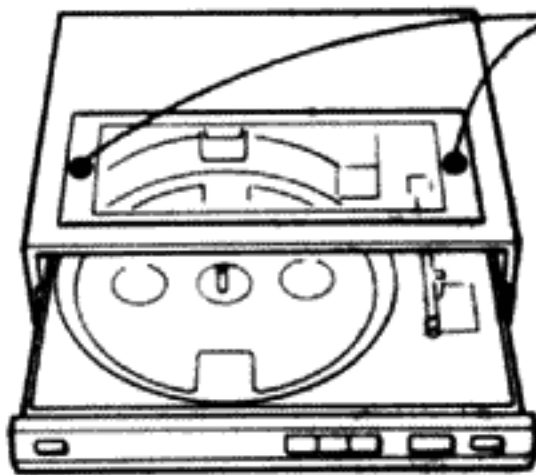

Unscrew the two screws using a coin or a screwdriver and remove the glass plate.

The **OPEN/CLOSE** button does not activate when the power is turned off. Never push or pull the module forcibly.

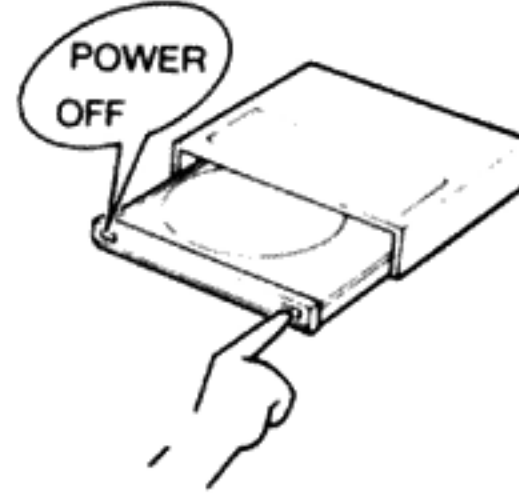

Do not push down on the module.

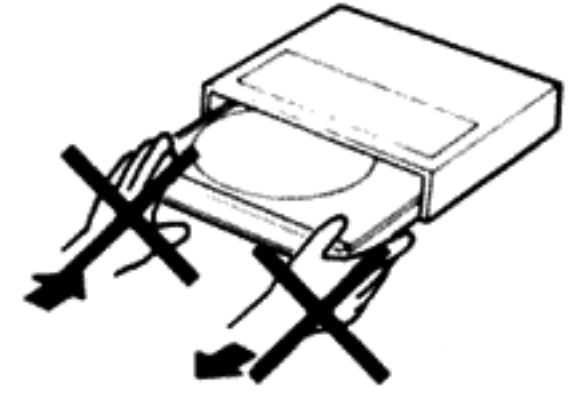

Do not stop the module when it is moving.

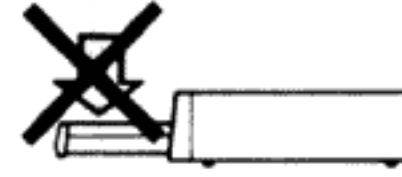

Be careful that no foreign object is caught between the module and the cabinet.

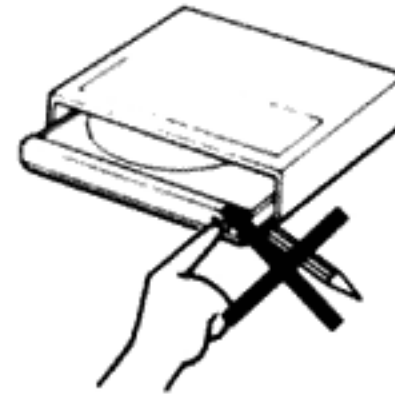

If the foreign object should be caught in this position, press the **OPEN/CLOSE** button immediately so that the module will move to the opposite direction. If you leave the foreign object between the module and the cabinet for 15 seconds, the module will automatically move to the opposite direction.



② Carefully place the platter on the motor board by fitting the center hole over the center spindle. Be careful that no foreign objects lodge under the platter.

● Do not touch the magnetic coating or the magnetic pick-up head.

③ Place the rubber mat on the platter, by matching the projections on the back of the rubber mat to the holes on the platter, and also the holes for record size selection on the rubber mat to those on the platter.

Do not use the rubber mat other than the one supplied.

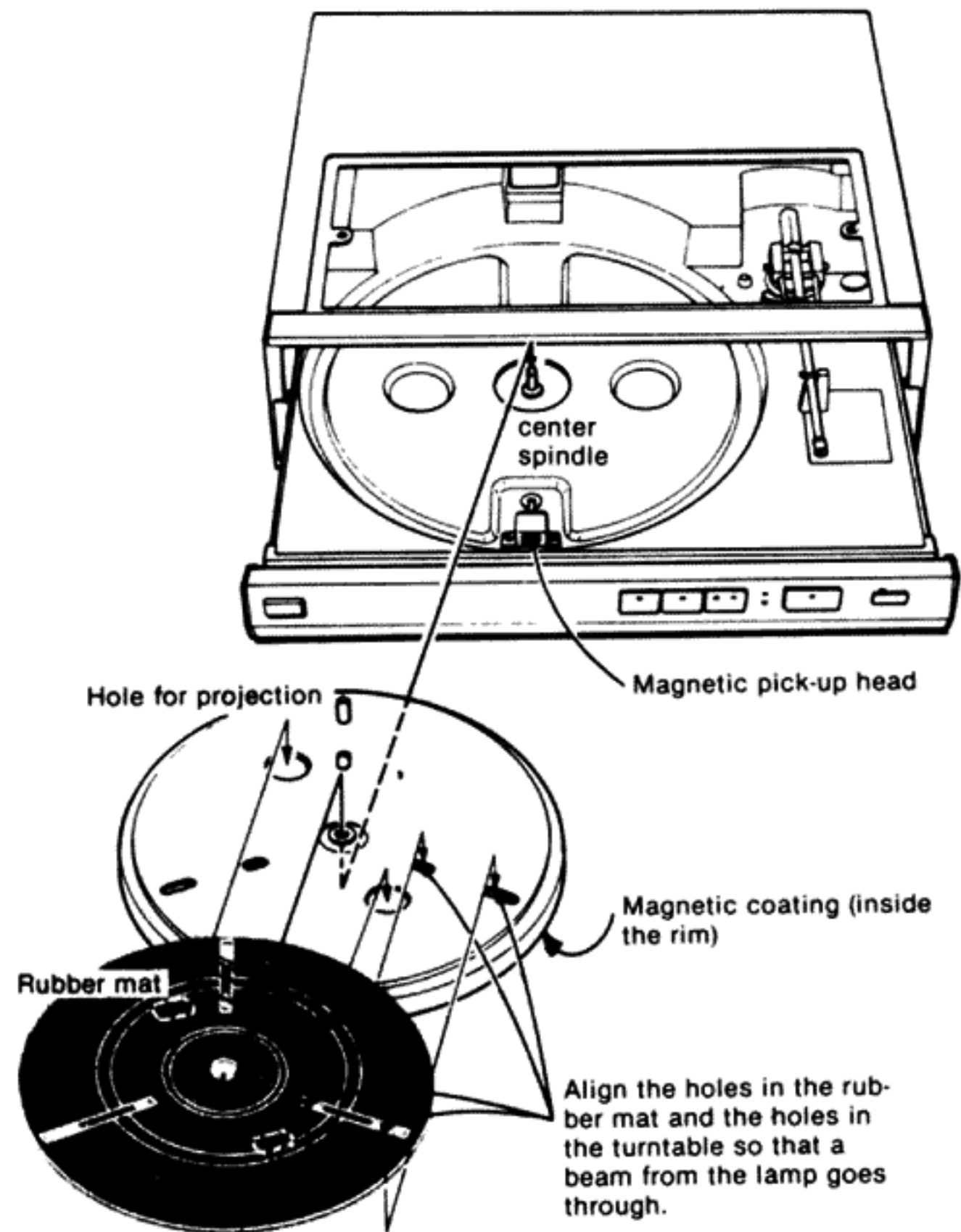

## TONARM ADJUSTMENT

The turntable must be on a level surface while the tonearm is being adjusted. Be careful not to damage the stylus tip while making adjustments.

### TONARM BALANCE ADJUSTMENT

It is critically important for good sound reproduction that the stylus traces the record groove accurately and with the proper tracking force. To do this, the tonearm must first be balanced so that the proper tracking force can be applied.

To balance the tonearm, proceed as follows :

① Secure the tonearm to the arm rest and insert the counterweight and the cartridge shell.

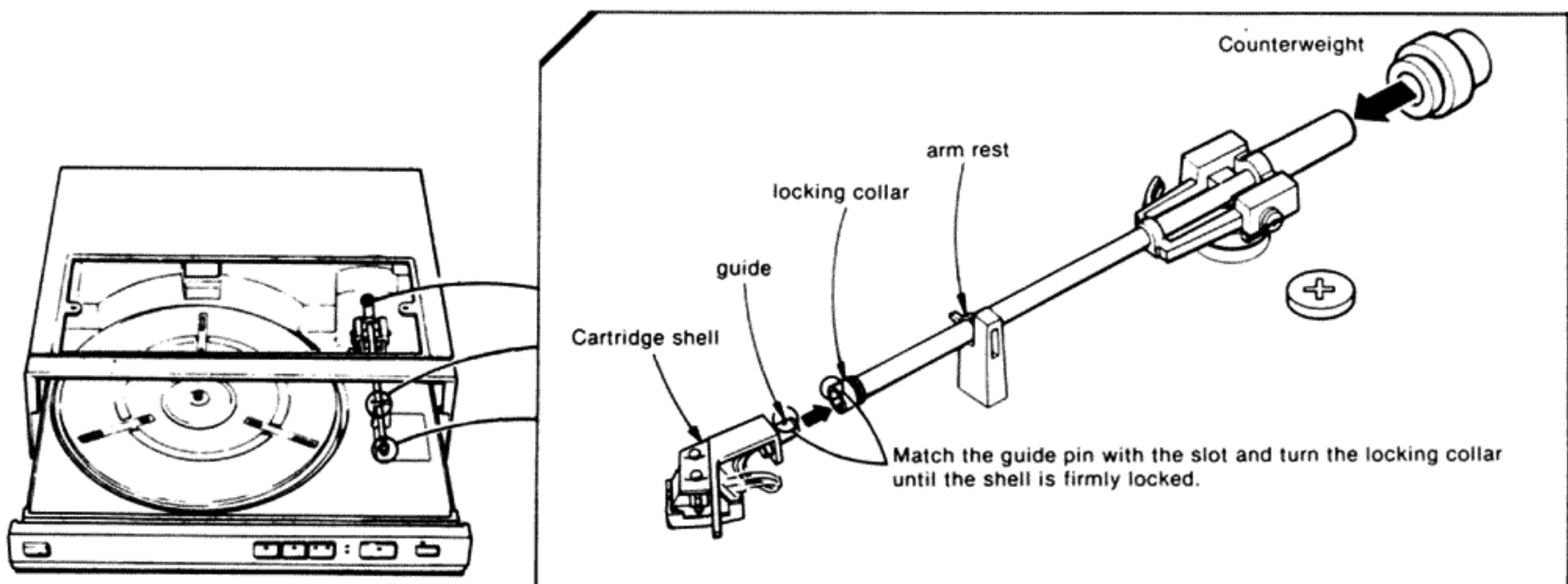

# PS-FL5/FL5C

② Press the ARM LIFTER button. This will cause the turntable to rotate and the cueing platform to lower. After the cueing platform has lowered, press the POWER button again to turn the unit off and stop the turntable by hand.

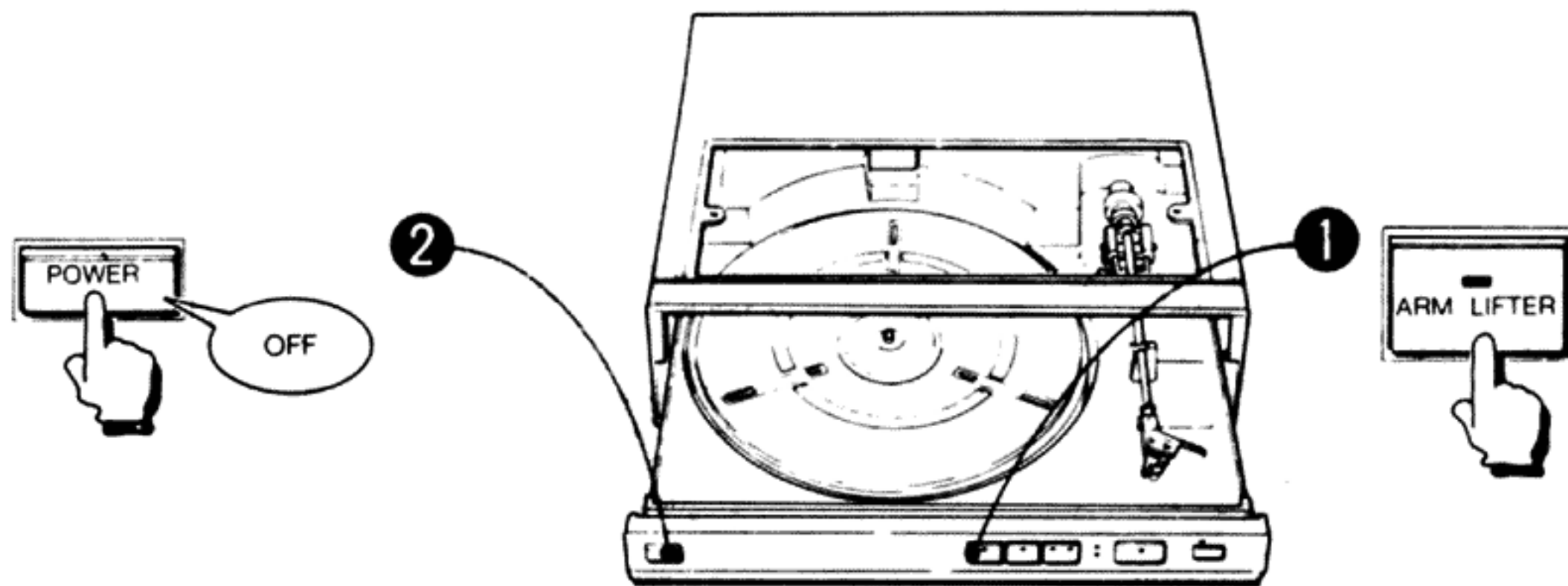

- ① Set the anti-skating compensator to "0".
- ① Remove the stylus guard and release the tonearm from the arm rest.
- ③ Adjust the position of the counterweight by turning it.
- ④ After the tonearm is balanced, replace the stylus guard and secure the tonearm to its rest.

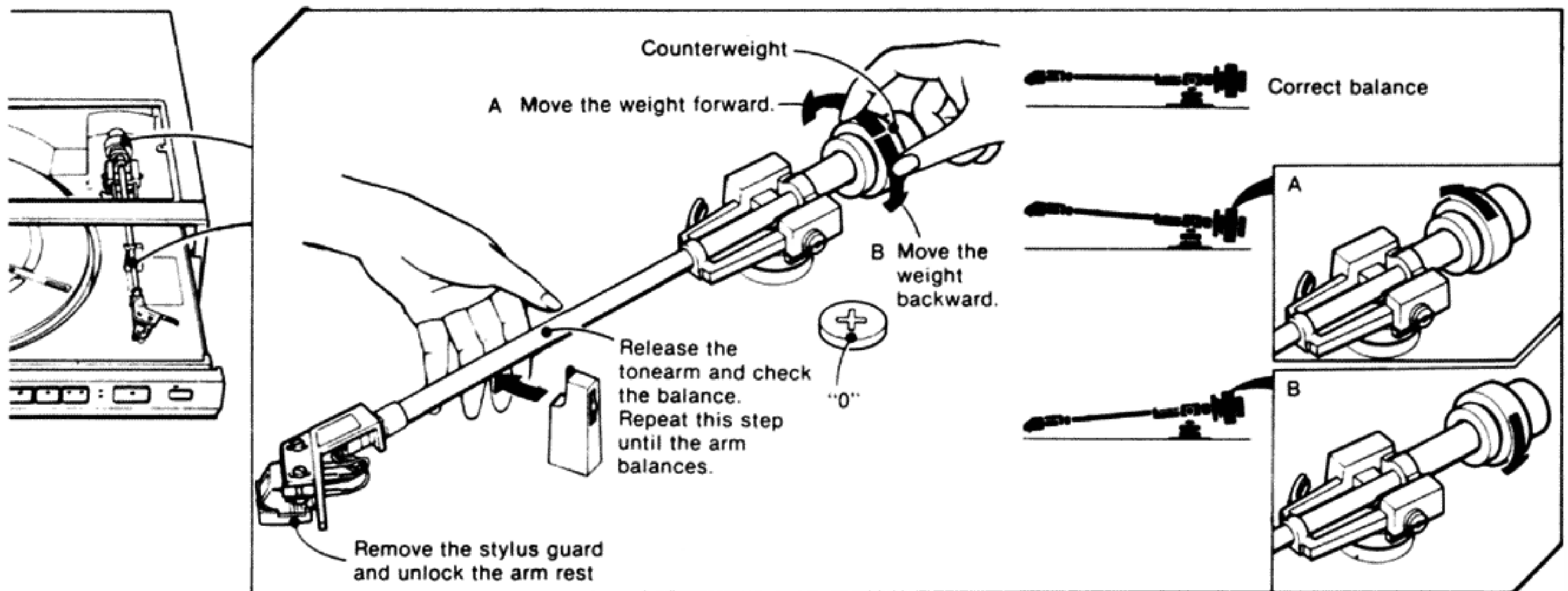



① While making sure that the counterweight remains in the balanced position, carefully turn the tracking force ring until the "0" indication is aligned with the center line on the tonearm.

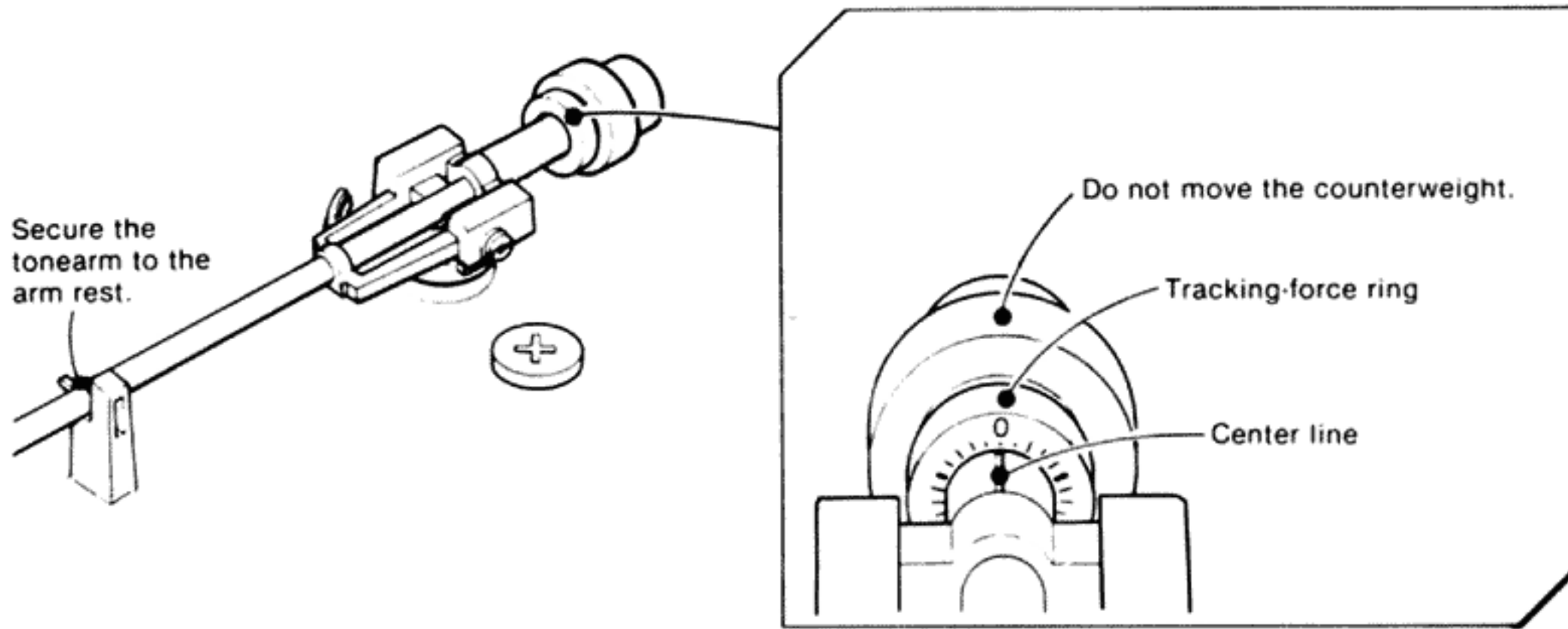

### TRACKING FORCE \* 1 ADJUSTMENT

Turn the counterweight as illustrated so that the recommended tracking force for your cartridge is aligned with the center line on the tonearm. The maximum tracking force available is 2.5 grams.

### ANTI-SKATING \* 2 COMPENSATION

Turn the anti-skating compensator so that the guide mark is aligned with the selected tracking force value.

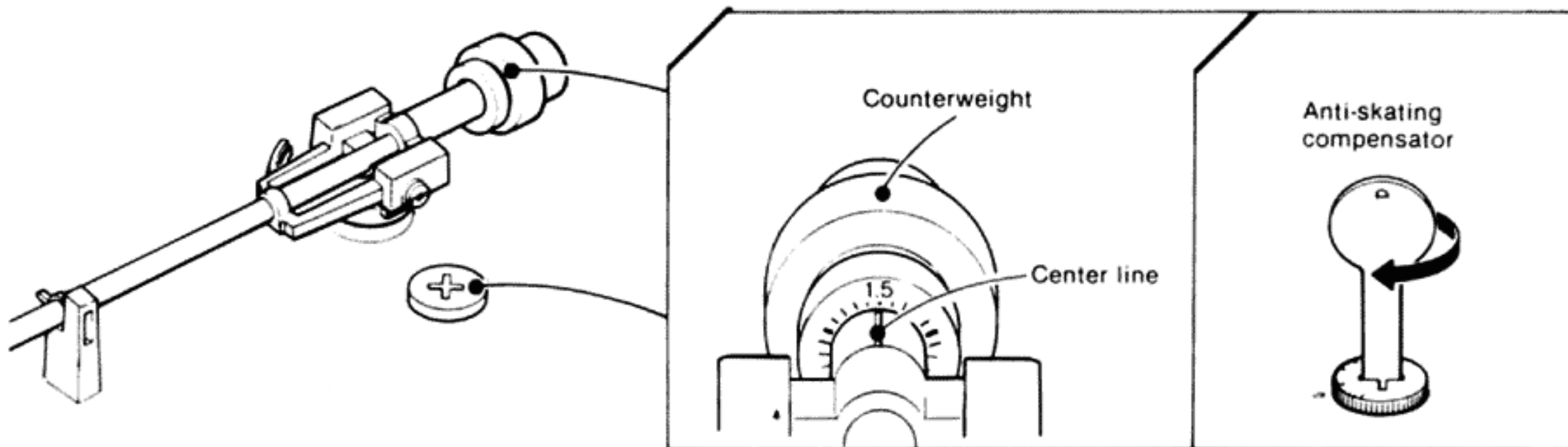

### OVERHANG CHECK \* 3

Check that the cartridge is correctly installed, using the alignment gauge on the underside of the rubber mat. If the installation is incorrect, the tonearm drop-point during auto play will be incorrect.

- ① Place the rubber mat upside down.
- ② Turn the power on and press the ARM LIFTER button. After the cueing platform has lowered, press the POWER button again to stop the turntable.
- ③ Bring the tonearm over the point where the two fine lines cross and carefully lower the stylus to this point.
- ④ Check to see that the head shell is parallel to the lines marked on the rubber mat. If it is not, loosen the cartridge mounting screws and slide the cartridge to the required position. Tighten the screws and recheck the balance and tracking-force.

### AFTER THE TONEARM ADJUSTMENT

When the tonearm adjustment is completed, replace the glass plate and secure with the screws.

#### \* 1 Tracking force

Tracking force is the vertical force applied to the stylus tip so that it can accurately trace a record groove.

The tracking force is applied after the tonearm is balanced.

Since the proper tracking force differs depending on which cartridge is installed, be sure to apply the tracking force recommended for your cartridge. If the tracking force is too light, the stylus will skip grooves. When it is too heavy, the stylus tip and the record will wear excessively. Note that if you play a record at a temperature below 10°C (50°F), or if the record to be played is badly warped, the tracking force should be increased by 20%.

#### \* 2 Anti-skating compensator

While the record is being played, friction between the record groove and the stylus produces a force that tends to drive the tonearm toward the center of the record.

The anti-skating compensator cancels this force. The anti-skating force should be the same value as the tracking force.

Incorrect adjustment of the anti-skating compensator results in sound distortion and uneven wear on both the stylus and the record.

#### \* 3 Overhang

While record grooves are cut by a head which tracks a record's radius in a line, a tonearm, because it is pivoted, traces an arc on a record. To compensate for this difference in movement, the head shell is angled and the cartridge is installed with a 16.5mm overhang. The correct overhang is obtained by installing the cartridge with a 37.5mm space between the stylus tip and the end of the cartridge shell and by checking the installation with the alignment gauge.

# PS-FL5/FL5C

## CONNECTIONS

- Turn off the amplifier before making connections.
  - Be sure to insert the cable connectors firmly into the jacks.
- Loose connections may cause hum and noise.
- Leave a little slack in the connecting cord to allow for inadvertent shock or vibration.

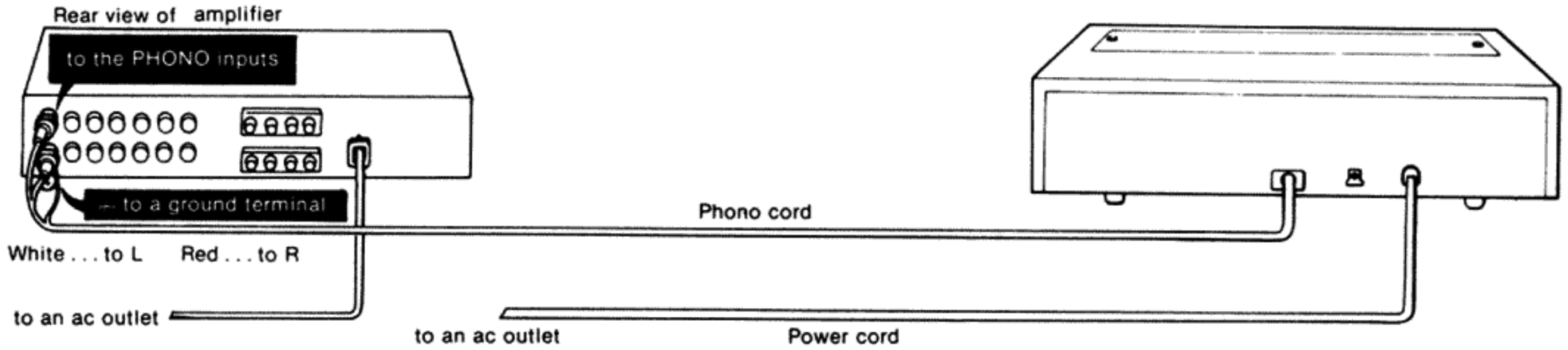

## RECORD PLAYING

### PREPARATION

- Place a record on the platter. For 17 cm (7 inch) records, put the supplied 45-rpm adaptor over the center spindle.
- Unlock the arm rest latch during operation. After playing, secure the tonearm to the arm rest.

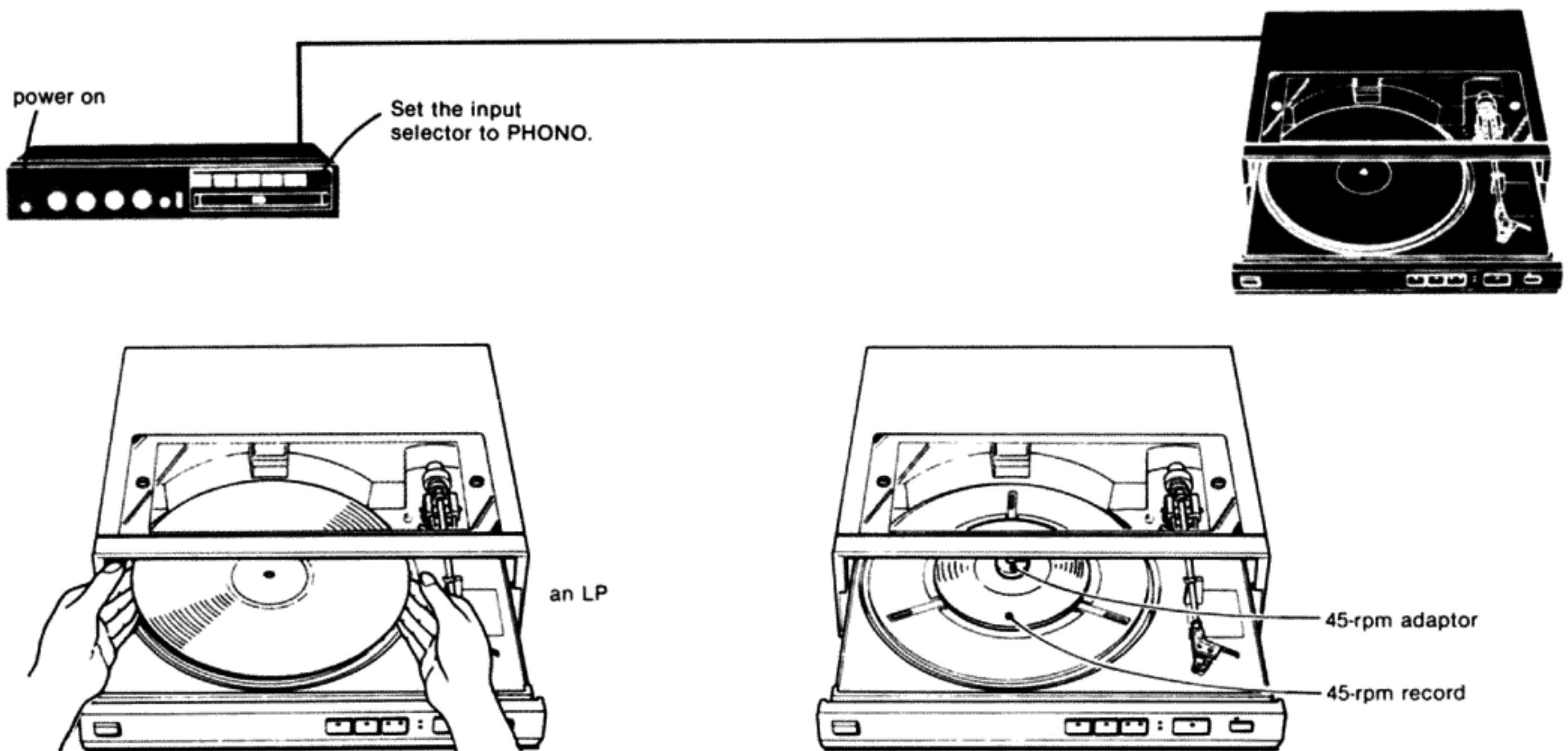

### Record

With transparent or badly warped records, the auto record size selection does not operate. In this case, play a record in the following way:

- For 30 cm (12 in) records, bring the tonearm onto a record and press the ARM LIFTER button, or cover the holes for auto record size selection by turning the rubber mat half a circle and press the START/STOP button.
- For 17 cm (7 in) records, place the supplied sheet underneath a record to cover the holes and play a record pressing the START/STOP button or ARM LIFTER button.

**AUTO PLAY**

❶ Press the POWER button (ON).

Select the correct record speed. The record speed will always be 33 $\frac{1}{3}$  rpm unless the SPEED selector is pressed to select 45 rpm.

❷ Press the START/STOP button. Play will begin.

❸ When the tonearm reaches the end of the record, it will automatically return to the arm rest and the turntable will stop.

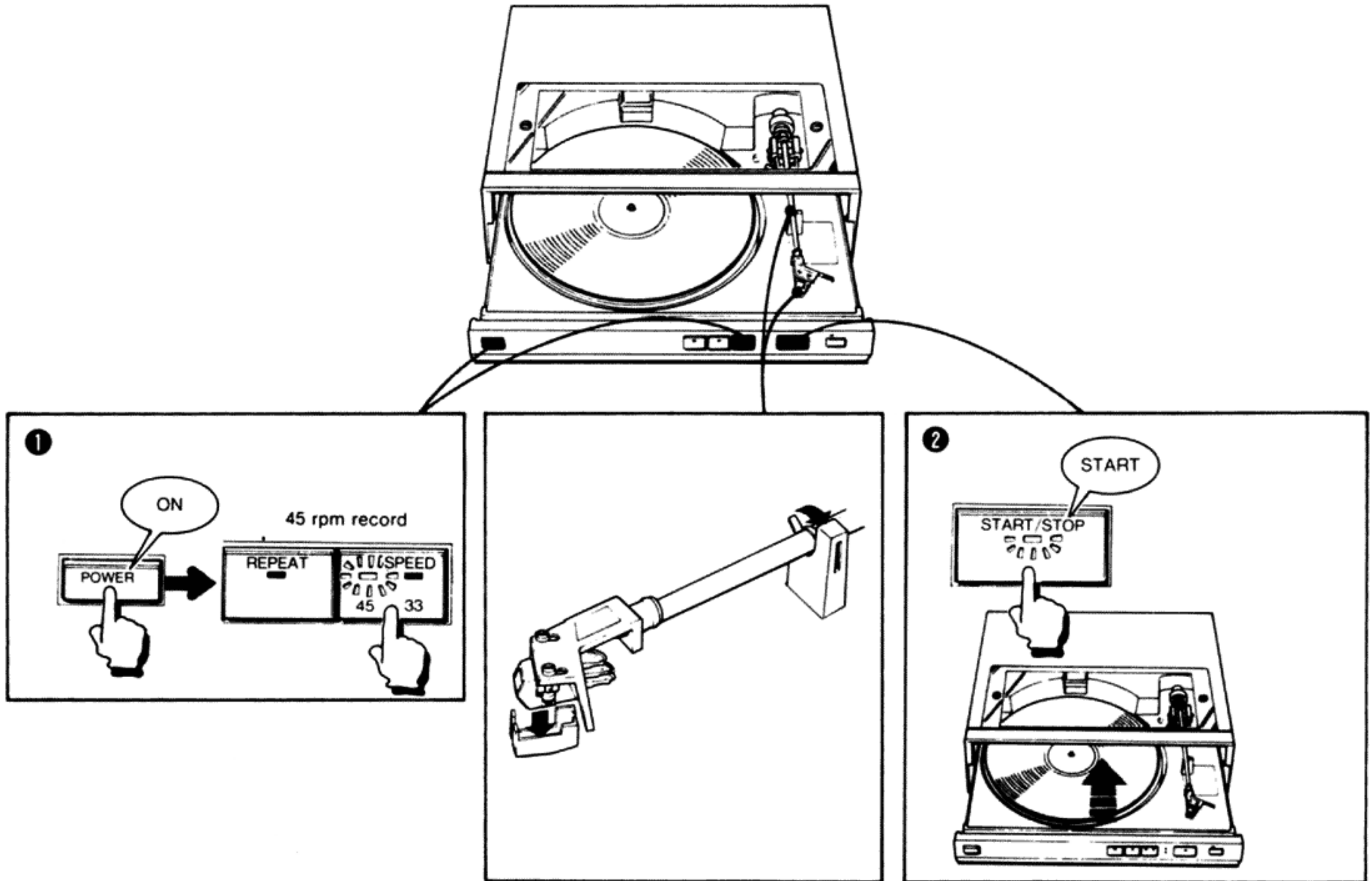
**Notes**

● 25 cm (10 inch) records can't be played automatically. To play these records, bring the tonearm onto a record and then start the playing, following the instructions in "Manual play" on the next page.

● Turn off the POWER button after the tonearm returns to the arm rest. If the POWER button is turned off while the tonearm is returning to the arm rest, when you press the START/STOP button the next time the tonearm will return to the arm rest and the record will not be played. If this happens, press the START/STOP button again.

If the turntable rotates out at an abnormal speed for a certain time, such as might happen if you slow it by hand or apply a record cleaner, the safety mechanism may activate to return the tonearm to the arm rest.



## MANUAL PLAY- for playing records at any point

- ❶ Press the POWER button (ON).
- Select the correct record speed. The record speed will always be 33 $\frac{1}{3}$  rpm unless the SPEED selector is pressed to select 45 rpm.
- ❷ Bring the tonearm to the desired position over the record.
- ❸ Press the START/STOP button. The module will close, the tonearm will lower to the record and play will begin.
- To play with the module opened, press the ARM LIFTER button. In this case, auto return and repeat may not activate at the end of the groove. Press the START/STOP button to return the tonearm to

the arm rest.

- ❸ When the tonearm reaches the end of the record, it will automatically return to the arm rest and the turntable will stop.

### Note

If you lower the tonearm too near the record label, the auto return mechanism may not activate at the end of the groove. This is because the tonearm reaches the end of the record before the auto return detector can activate.

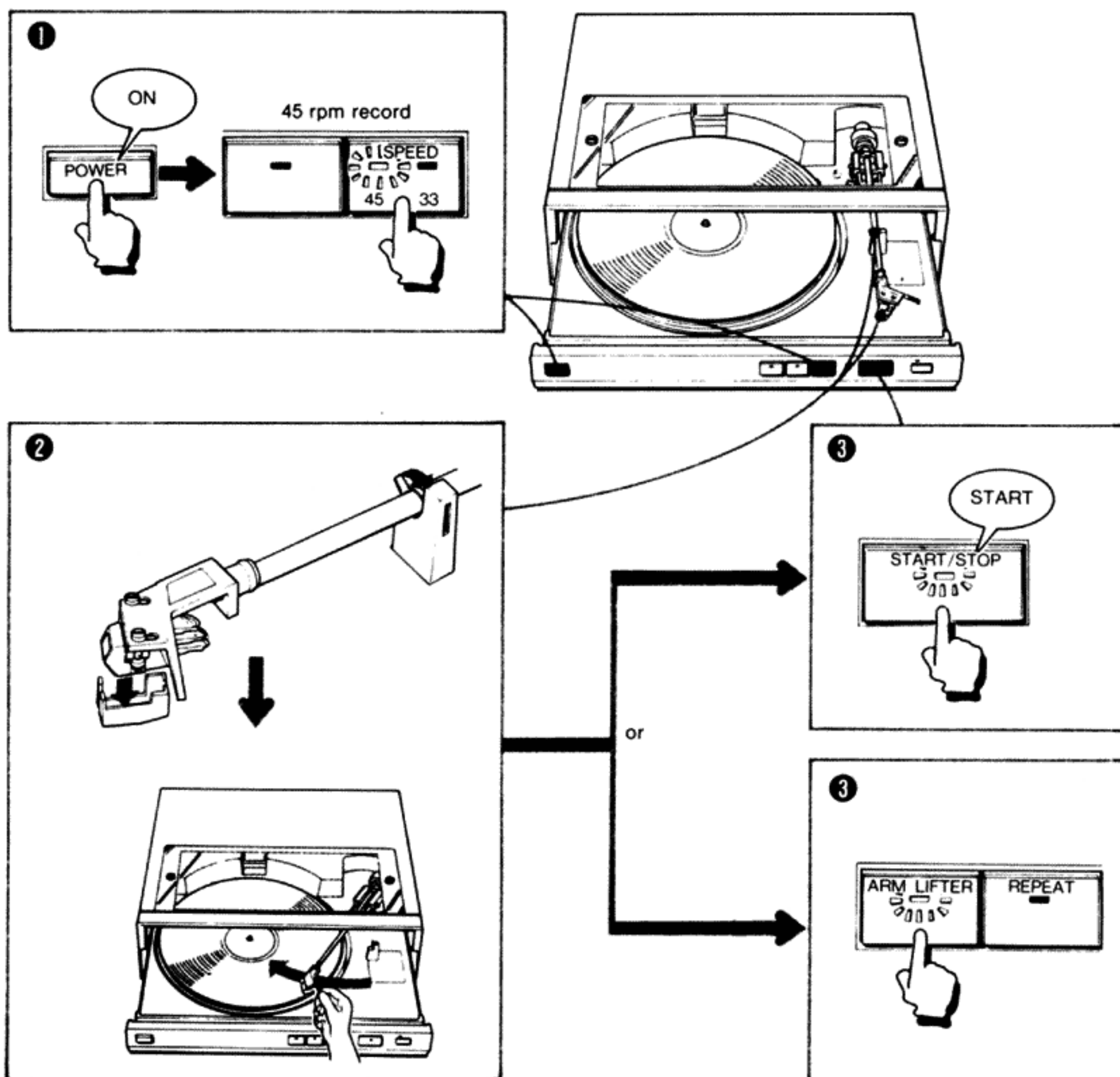

## TO LIFT UP THE STYLUS DURING PLAY

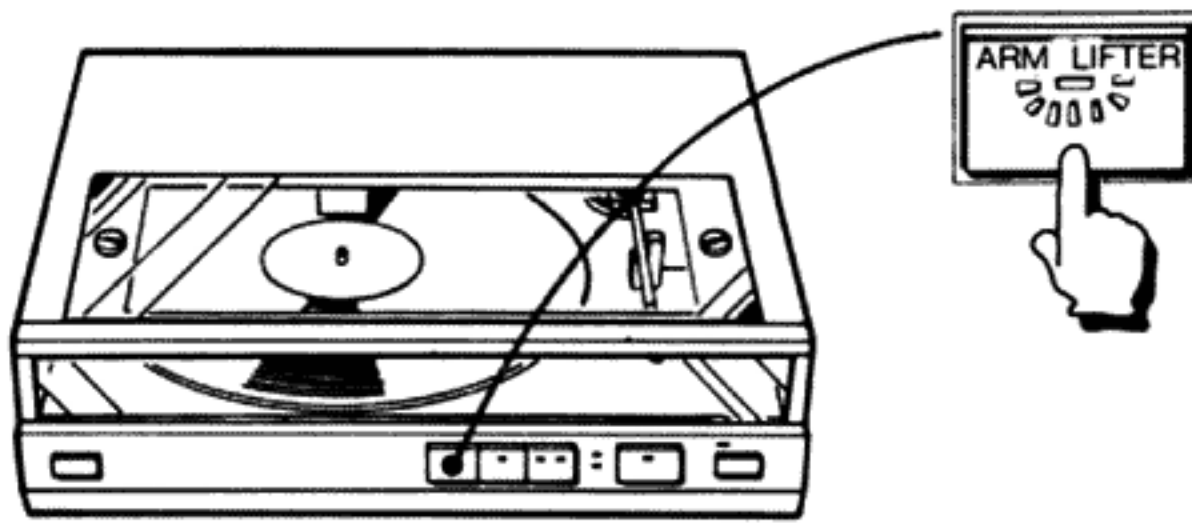

To lift the stylus from a record for a moment and then start playing from the same point, press the ARM LIFTER button. To lower the tonearm onto the record, press the button again.

## TO STOP DURING PLAY

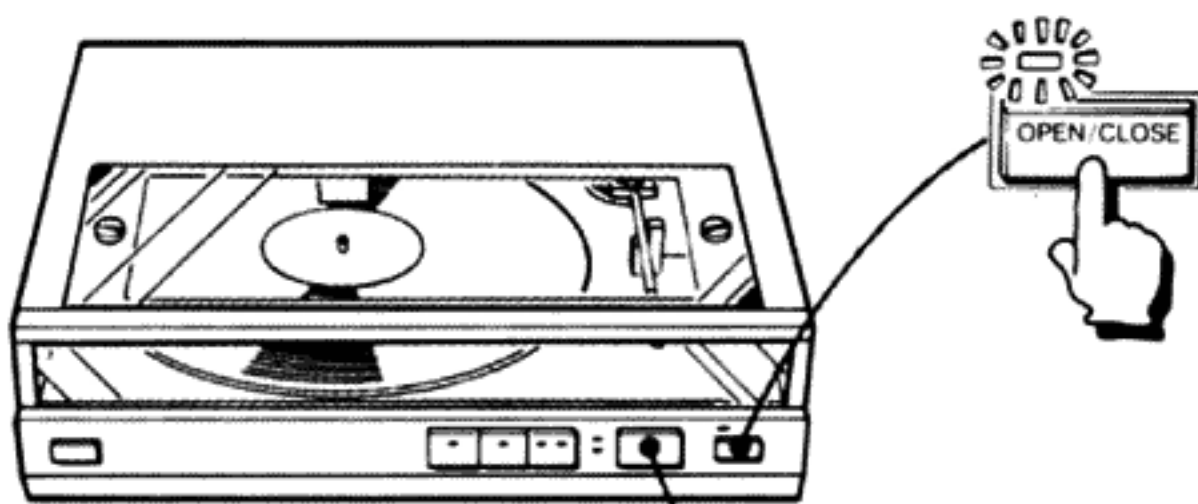

Press the OPEN/CLOSE button. The tonearm will return to the arm rest, the turntable will stop rotating and the module will open. (When the module has opened, a touch of this button will close the module.)

or

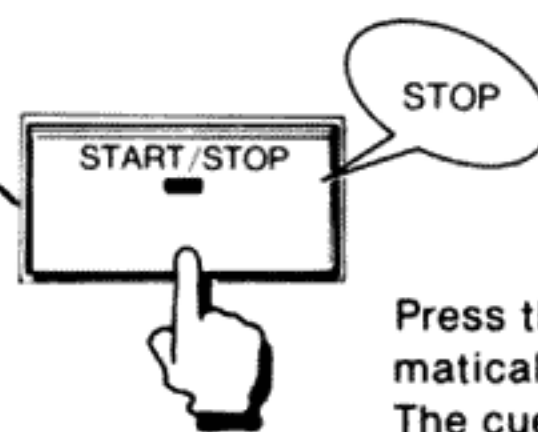

Press the START/STOP button. The tonearm will lift up and automatically return to the arm rest. The cueing platform will lower when the tonearm reaches the arm rest and the unit will be turned off.

## TO REPEAT PLAY

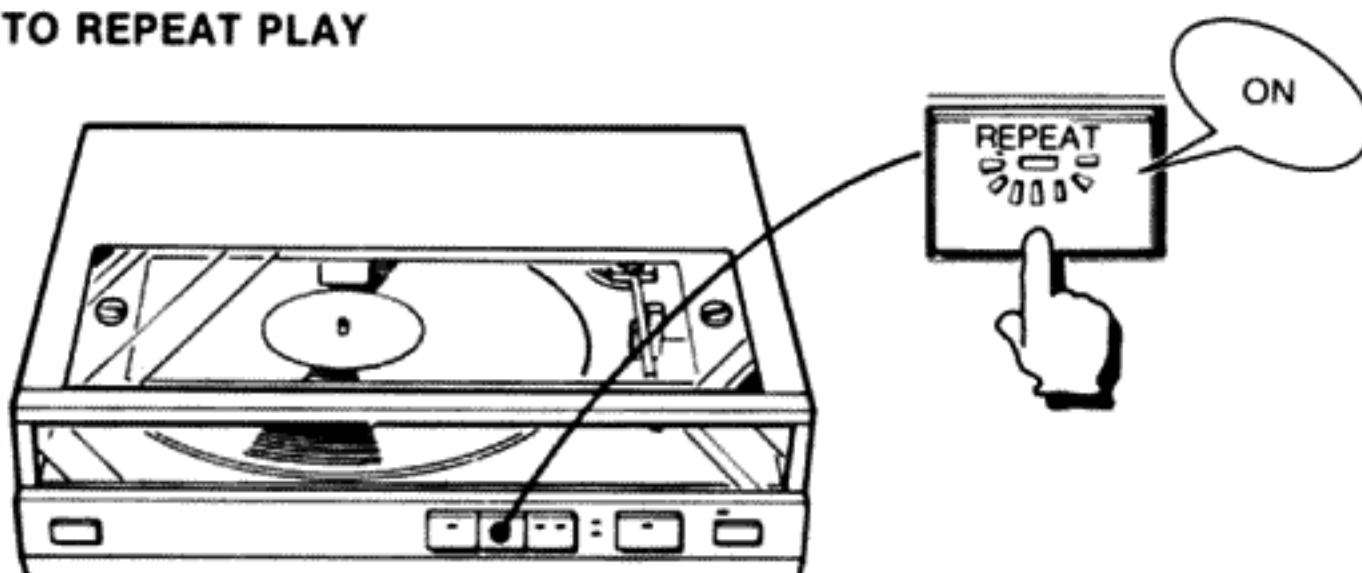

Press the REPEAT button either before or after starting play. The tonearm continues repeat play unless the button is pressed again to turn off the repeat function. To stop during repeat play, press the START/STOP button.

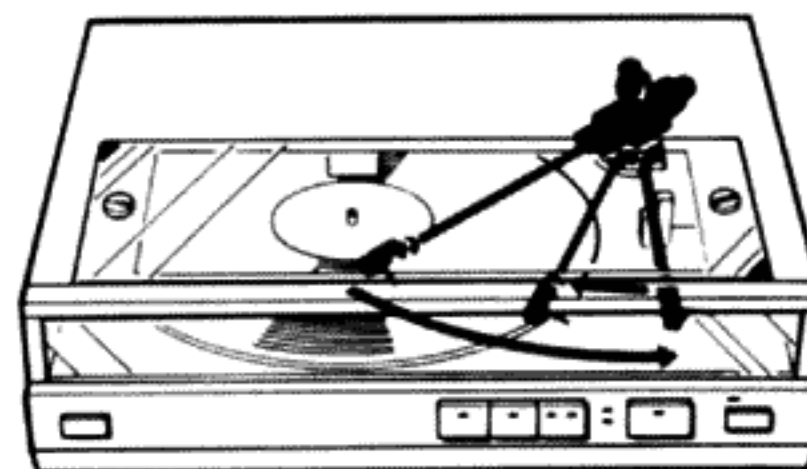

## SYNCHRONIZED PLAY OF THE TURNTABLE AND THE CASSETTE DECK

Record recording starts only when the START/STOP button is pressed. When the tonearm lowers to the record, the tape deck goes into the record mode and, when the tonearm is lifted up, the deck goes into auto record muting mode for four seconds, then into the pause mode.

Connection and operation are as follows:

Cassette deck which can be used with your turntable for this special synchronized operation are those Sony models which are equipped with a 4-pin remote control jack. An RM-65 synchro remote control unit (optional) is required to connect the turntable and the cassette deck.

### Connection and preparation

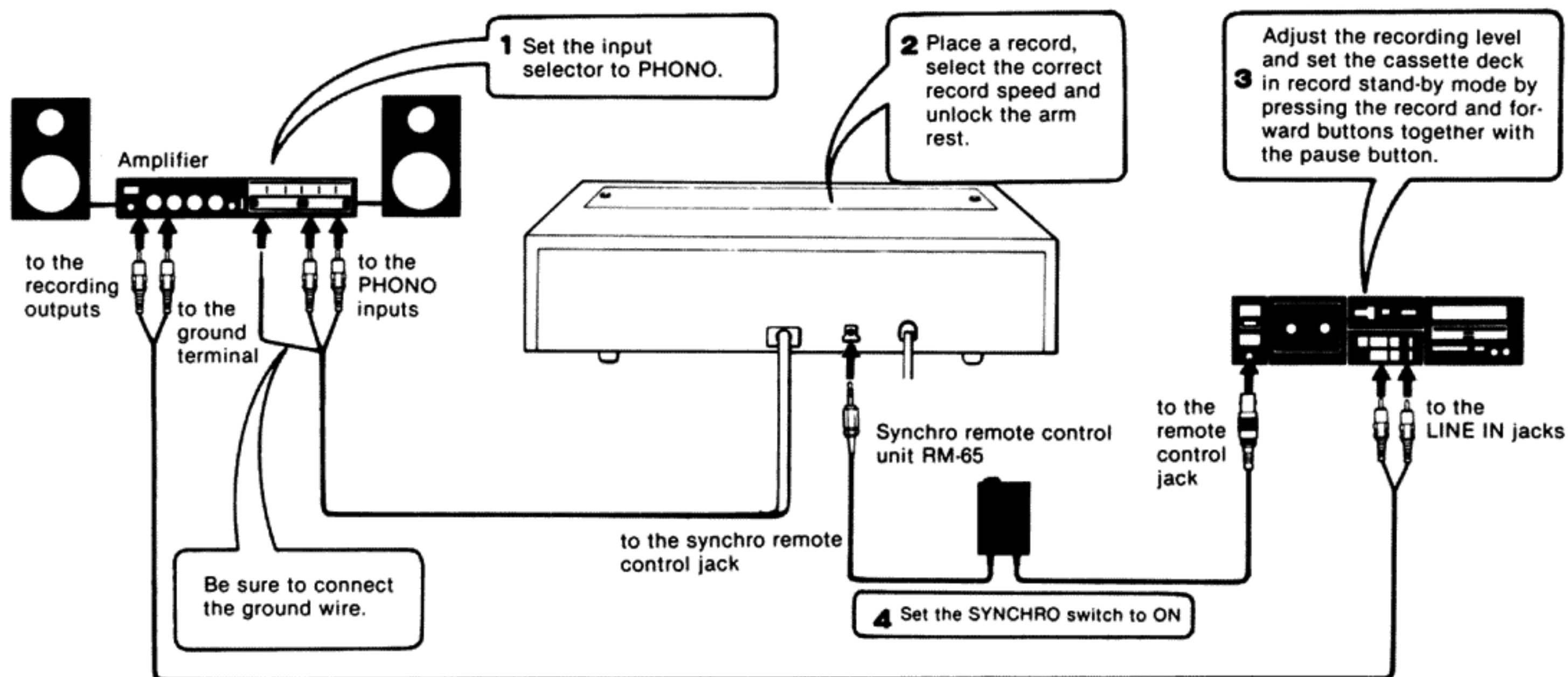

After turning the power of the turntable system on, set the SYNCHRO switch to ON and before turning the power of the turntable system off, set the SYNCHRO switch to OFF.

### RECORDING

Desired action	Turntable operation	Synchronized operation of the cassette deck
To record from the beginning of a record...	Press the START/STOP button.	When the tonearm lowers to the record, the pause mode is released and recording begins.
To record from a point some way into the record...	Bring the tonearm over the desired point and press the START/STOP button.	When the tonearm lowers to the record, the pause mode is released and recording begins.
To stop recording during record play...	Press the START/STOP button.	When the tonearm is lifted up, auto record muting activates for four seconds, then the pause mode is assumed.
When record play ends...	The tonearm returns automatically to the arm rest.	When the tonearm is lifted up, auto record muting activates for four seconds, then the pause mode is assumed.



## TIPS ON RECORD HANDLING

● Before playing, clean the record with a record cleaner or soft cloth. If a spray cleaner is used, make sure that it has dried completely before playing the record. Playing the record before the cleaner has dried may damage the record.

It is a good idea to clean the record again before putting it away.

● Handle a record by its edges and do not touch the grooves.

Fingerprints on the record surface may encourage an accumulation of dust, resulting in impaired tone.

● Use a commercially available anti-static spray to neutralize the static electricity on a record.

● Avoid exposing a record to direct sunlight or sources of heat, such as a hot-air duct.

● Store your records vertically. They should not be compressed.

## TONARM DROP-POINT ADJUSTMENT

The tonearm's drop-point during auto play has been adjusted at the factory. If this needs to be readjusted, proceed as follows.

❶ Press the OPEN/CLOSE button to open the module. Then unscrew the two screws and remove the glass plate.

❷ Remove the rubber cap over the tonearm drop-point adjustment opening located at the right side of the arm base.

❸ Insert the supplied drop-point adjustment key into the opening

To move the drop-point inward . . . turn the screw in direction A.

To move the drop-point outward . . . turn the screw in direction B.

● Be sure not to turn the screw in direction B so far that the stylus tip cannot make contact with the record.

❹ Start auto play and check that the stylus lowers on the correct drop-point.

● If the drop-point is correct for 30 cm (12 inch) records, it will also be correct for 17 cm (7 inch) records.

● You can keep the adjustment key in your key holder if you like may come in handy for a variety of jobs.

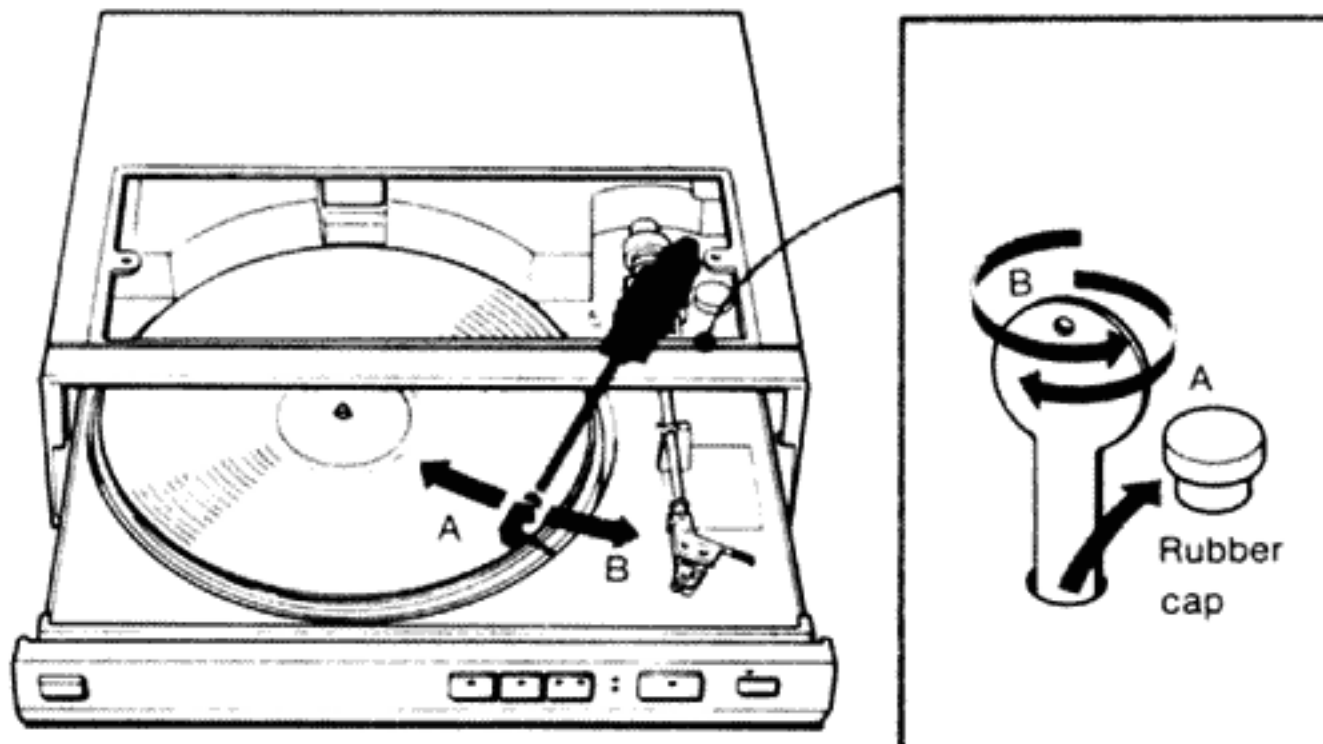

## REPLACING THE STYLUS

The stylus will lose its effectiveness and begin to damage records after about 400 hours of use.

An ND-200E replacement stylus is available at your Sony dealer.

Handle the stylus carefully as it is very delicate.

Install the replacement stylus as follows.

❶ Secure the tonearm to the arm rest and separate the shell from the tonearm by turning the locking collar.

❷ Detach the stylus assembly by grasping it between the thumb and forefinger and pulling gently in the direction of the arrow.

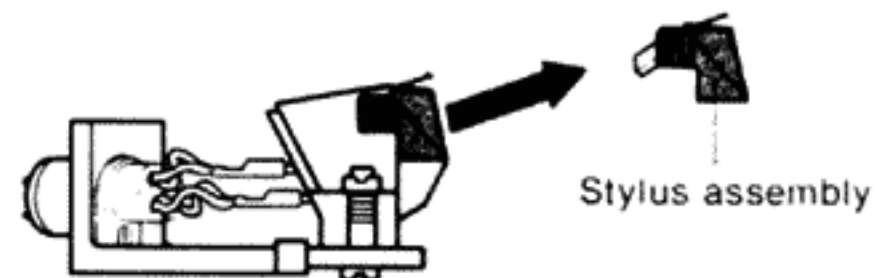

❸ Insert the new stylus into the cartridge.

❹ Plug the cartridge shell into the tonearm and turn the locking collar counterclockwise until the shell is locked.

## INSTALLING A CARTRIDGE OTHER THAN THE ONE SUPPLIED

Cartridges weighing from 2.5 to 6.5g can be mounted in the supplied cartridge shell (5g).

### Removing the old cartridge

- ❶ Secure the tonearm to the arm rest, then remove the shell from the tonearm by turning the locking collar.
- ❷ Remove the old cartridge by loosening the two mounting screws.
- ❸ Disconnect the lead wires of the shell from the four output terminals of the cartridge.

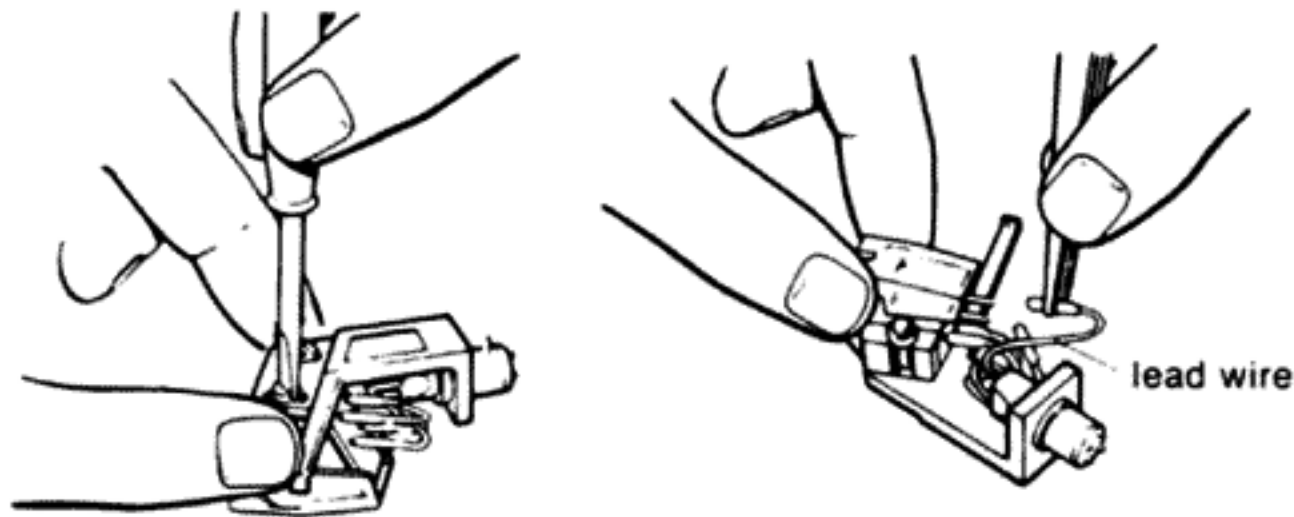

- ❹ Connect the lead wires of the shell to the corresponding pins on the cartridge.

### Wires

White . . . . .  
 Blue . . . . .  
 Red . . . . .  
 Green . . . . .

### Cartridge pins

White, L (Left channel signal)  
 Blue, LE or G (Left channel ground)  
 Red, R (Right channel signal)  
 Green, RE or G (Right channel ground)

- ❺ Temporarily install the new cartridge into the shell with the mounting screws as illustrated. Final adjustment should be made later during the overhang check.

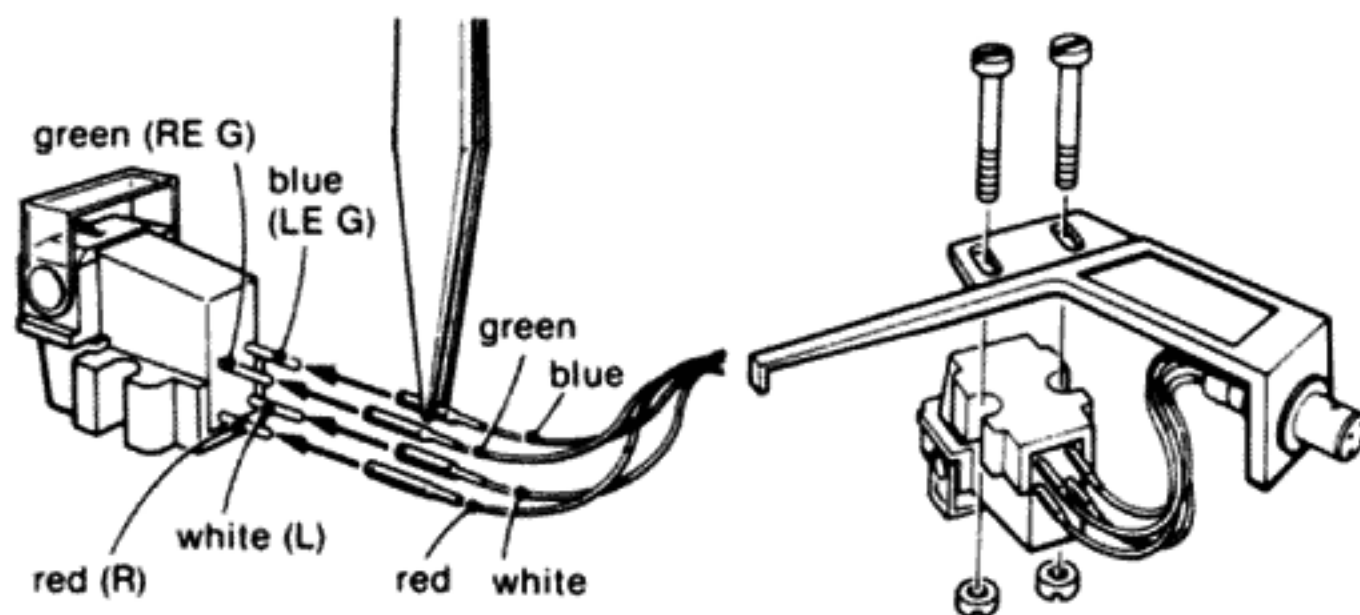

Place the cartridge shell exactly over the diagram and adjust the position of the cartridge

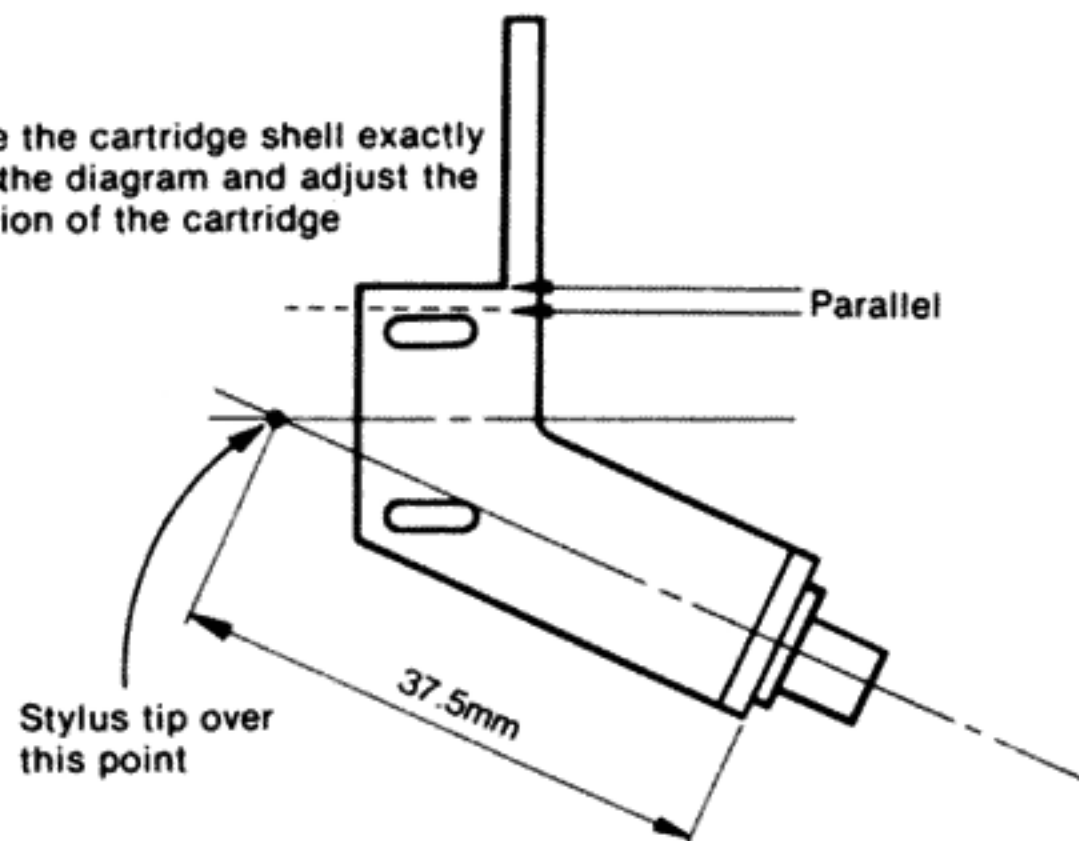

- ❻ Plug the shell into the tonearm and turn the locking collar counterclockwise until the shell is firmly locked.

## MAINTENANCE

### Stylus

Before playing a record, clean the stylus with a soft brush. Brush the stylus from back to front. Never attempt to clean the stylus with your finger tip. If fluid stylus cleaner is used, make sure not to moisten the stylus too much.

### Cabinet

Clean the cabinet and dust cover periodically with a soft dry cloth. If the stains are difficult to remove, use a cloth moistened with a mild detergent solution. Do not use solvents such as alcohol, benzine or thinner, since they will damage the finish.

### Rubber mat

When the rubber mat becomes dirty, wipe it gently with a soft cloth slightly dampened with water.

### Lubrication

The turntable requires no periodic lubrication. The motor shaft is lubricated at the factory for the life of the turntable.

## SECTION 2 DISASSEMBLY

### Notes on Removal, Repair and Adjustment

- When repairing or adjusting the set, care must be taken when turning the set upside down. Follow the procedures below.

When the set with bottom plate installed is turned upside down, the module is to be supported by the bottom plate as shown below.

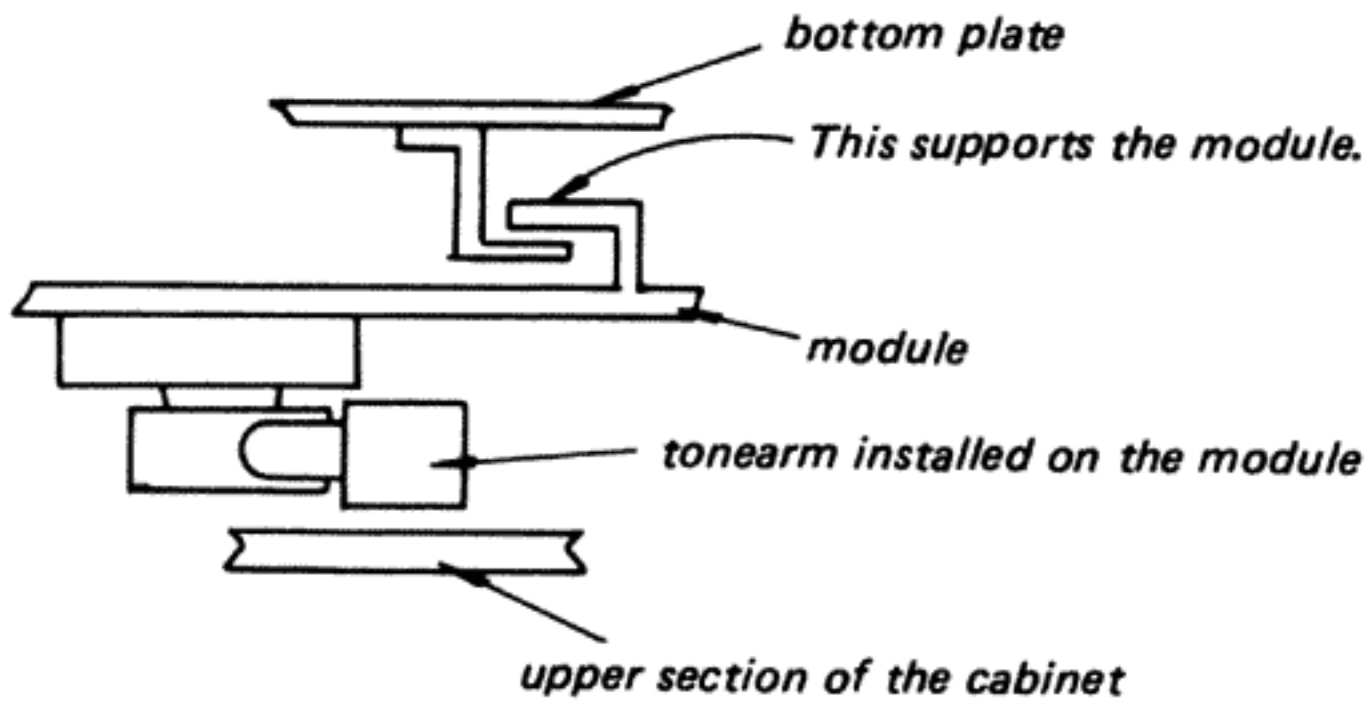

If the bottom plate is removed with the set in this position, the module will not only drop down, but also the front side of the set inclines and the tonearm will bend, because the cartridge will receive the weight of the front of the set. To avoid such damage, follow the procedures below.

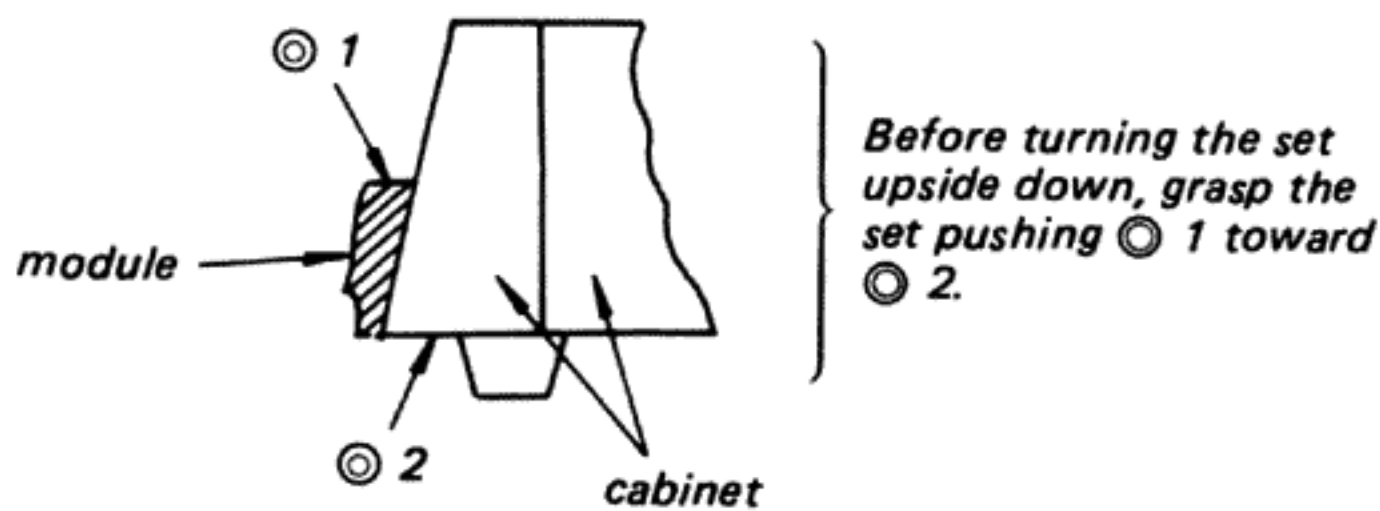

**Remove the bottom plate.**

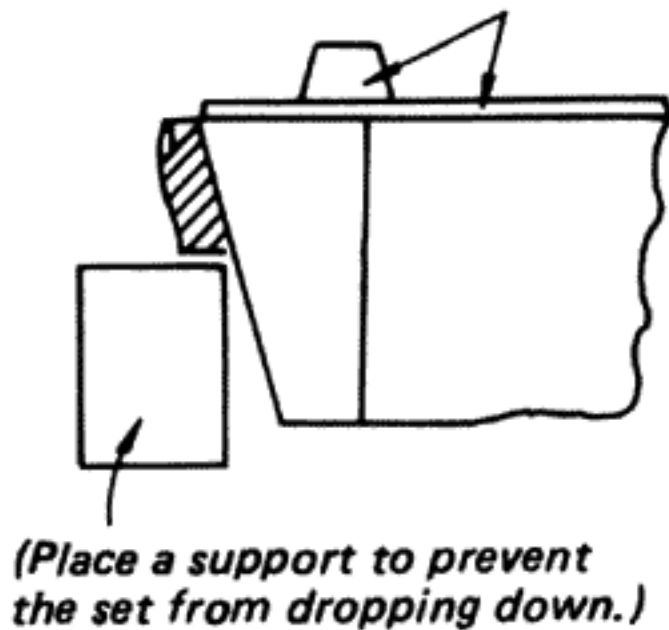

- Before removing the bottom plate, disconnect the power cord from the wall outlet, because the power transformer and power supply board are mounted on the bottom plate.

The power supply board has terminals for leads and they are always charged regardless of the status of the power switch.

When repairing the power transformer or power supply board, it is convenient to support the set by using the holes of the frame screws.

- Although the gear and motor for sliding the module keep rotating when the power switch is turned on with the bottom plate removed, this does not indicate a break down. Follow the procedures below.

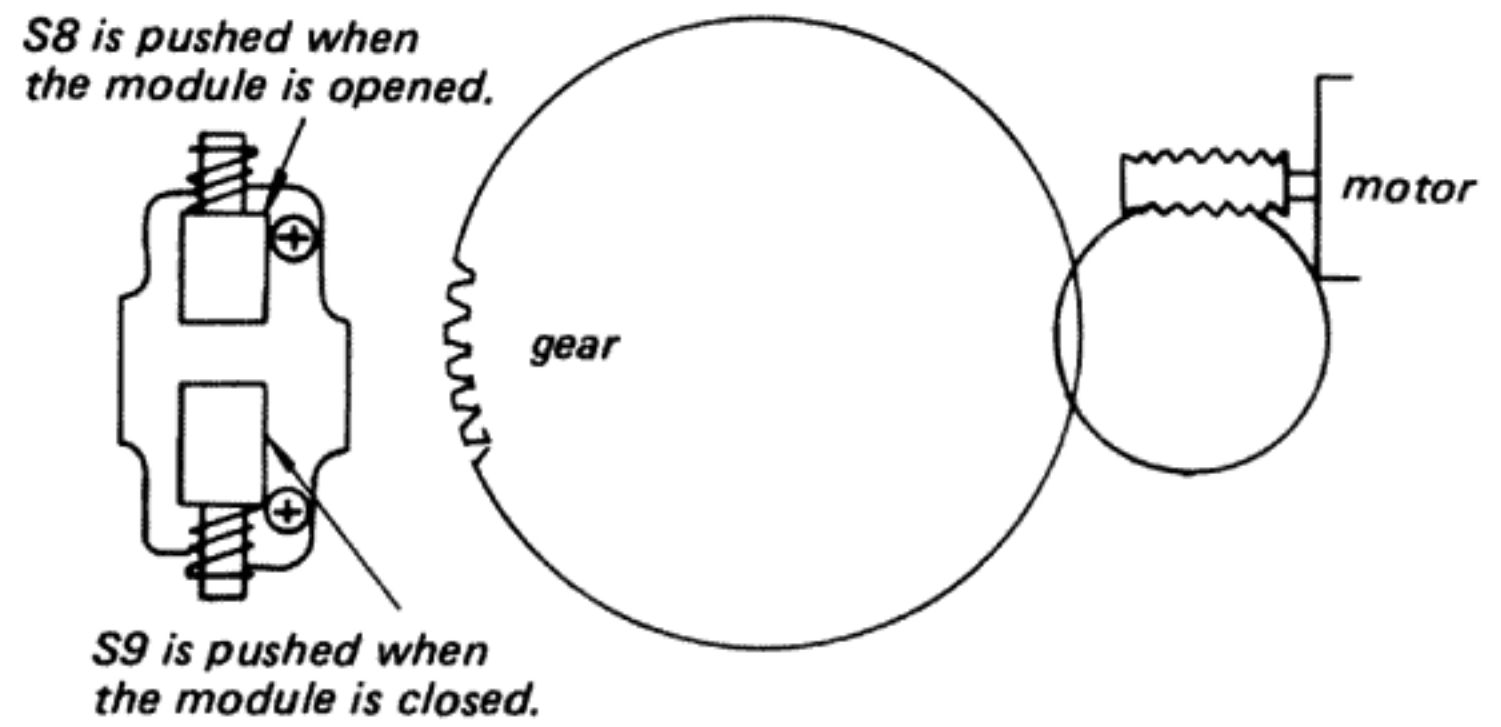

1. Before turning the power switch on, depress S9.
2. Turn the power switch on while pushing S9.
3. About 2 seconds later, release S9. (Until OPEN/CLOSE button is depressed, the computer does not see S8, 9.)



Note: Follow the disassembly procedure in the numerical order given.

## Top Cover/Front Panel/Control (B) Board

- ① - ② top cover
- ③ - ④ front panel
- ⑤ control (B) board

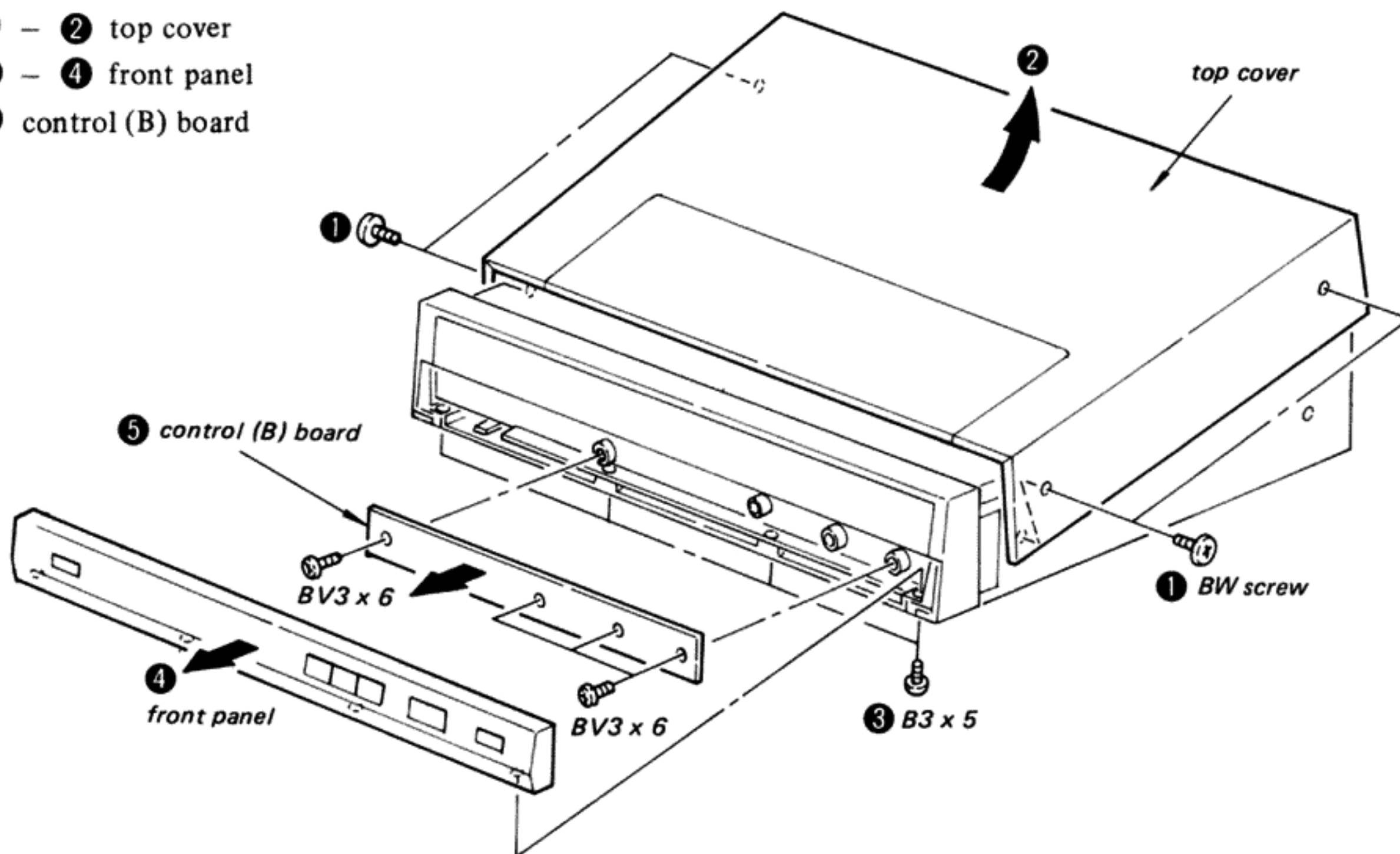

① - ②

## Turntable/Record Sensor (A) Board

When the turntable module does not slide out:

- ① - ② turntable
- ① - ⑤ record sensor (A) board

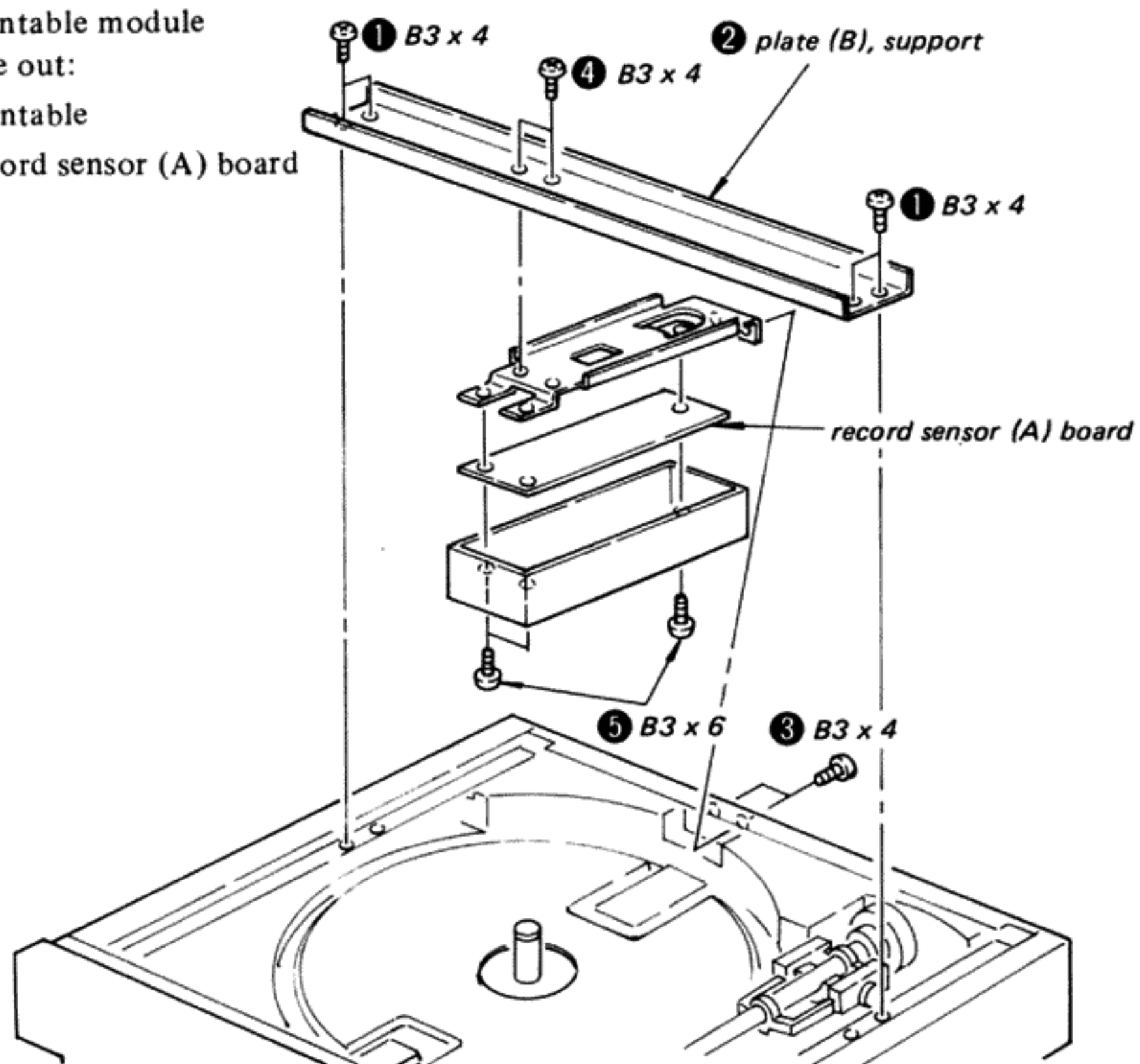

**Bottom Plate**----- **CAUTION:** Disconnect the power cord from the wall outlet, because the power supply board is mounted on the bottom plate.

① - ④ Remove the rack guide to free the rack panel.

⑤ To remove the guide plate from the motor and cover, slide the bottom plate 1cm to the left as shown in the figure and lift the front side of the bottom plate.

⑥ Remove the power transformer from the rear panel as shown below.

- notes on installing the switch plate -

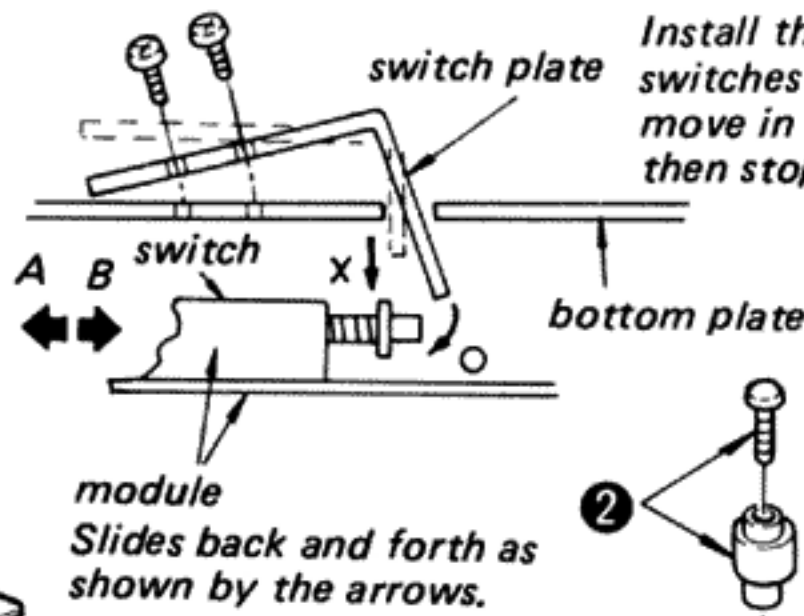

- Installation of the Bottom Plate -

Move the rack plate in the direction of the arrow and make sure that the module can be moved by hand. After confirming, return the rack plate (so that it engages with the drive gear) and install parts marked ②.

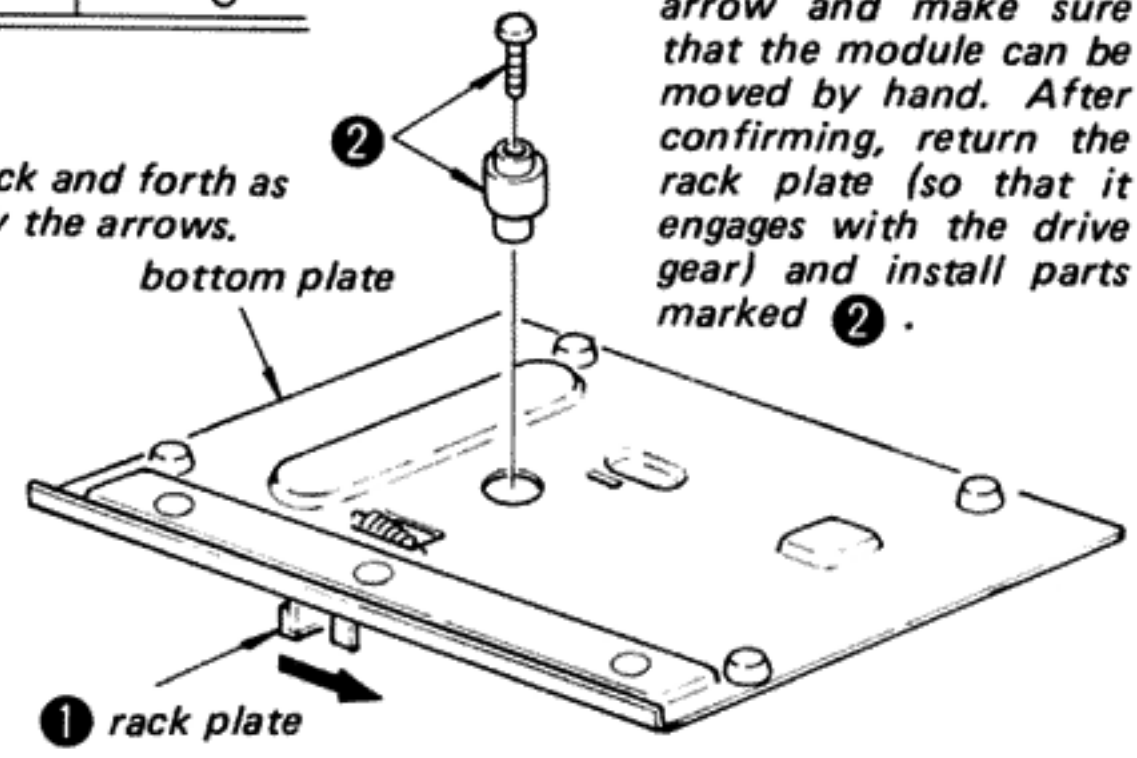
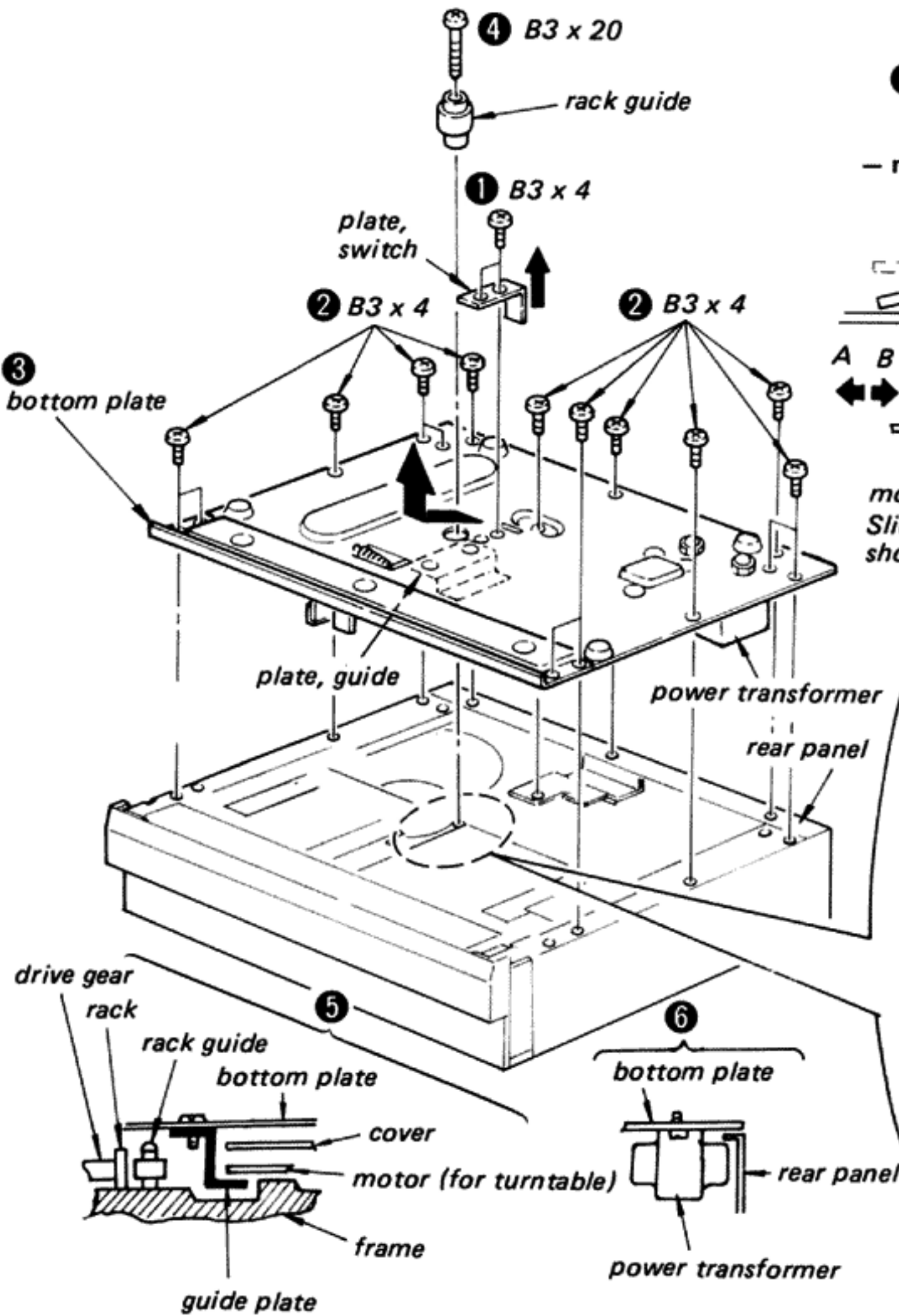

- reference illustration -

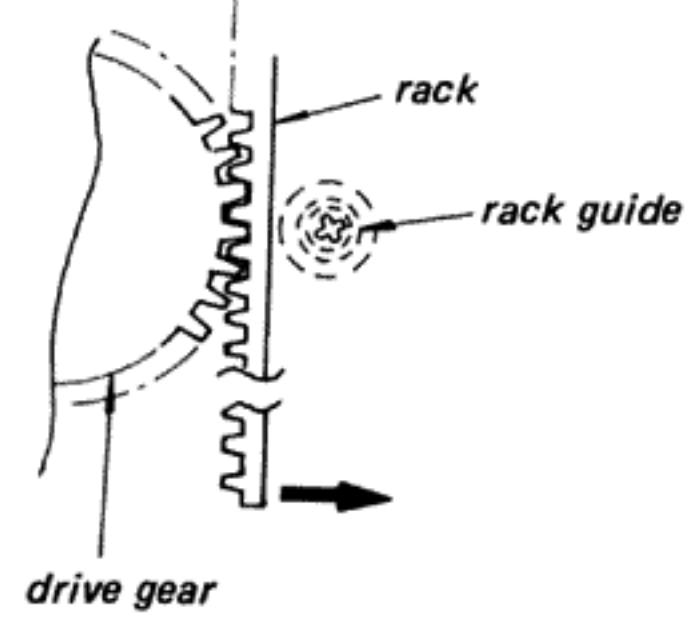

**Turntable/Turntable Sheet**

- When the module can slide out -

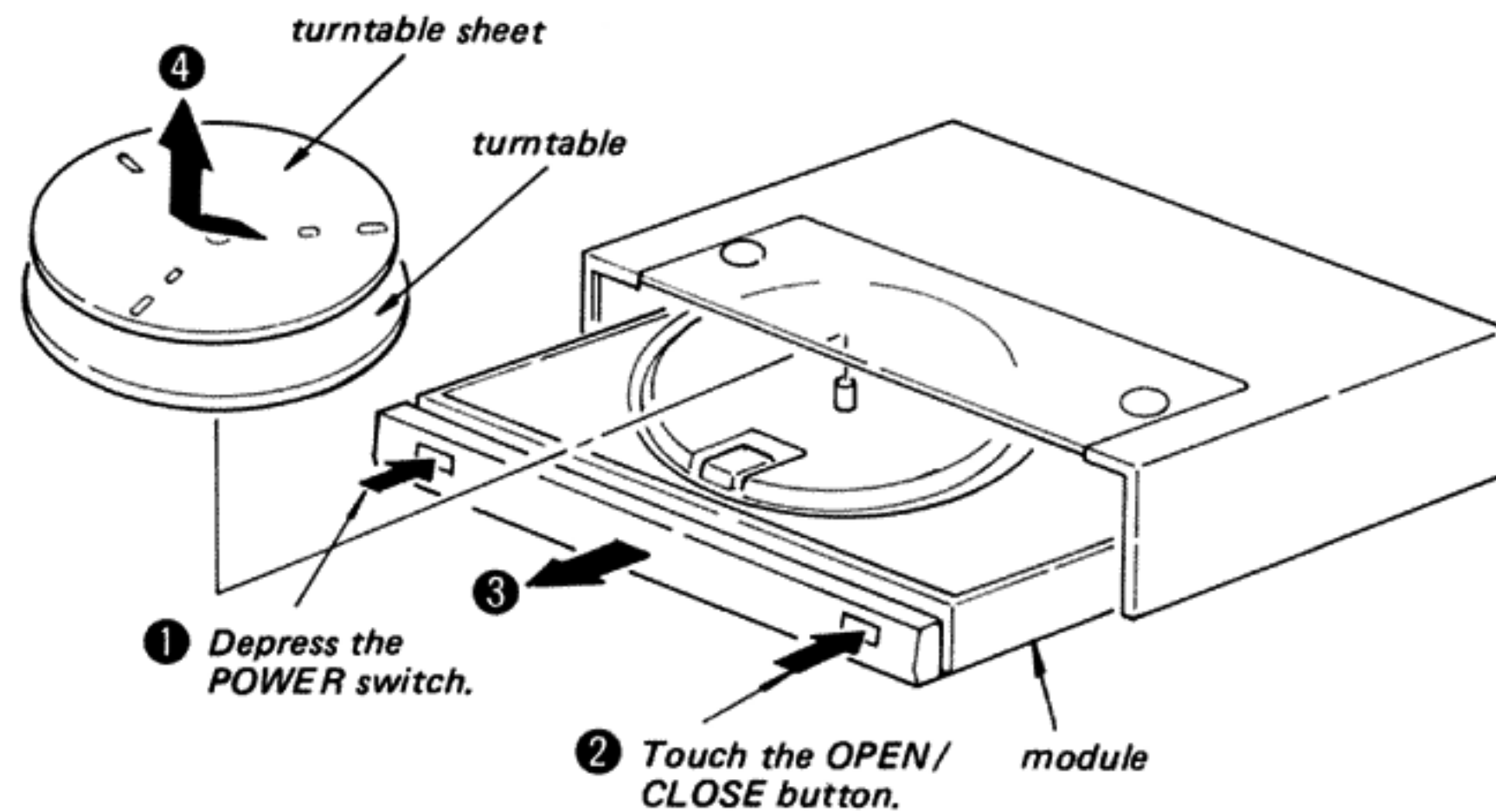

**Note:** When the module does not slide out because of troubles in the electrical section, remove the turntable after removing the top cover.

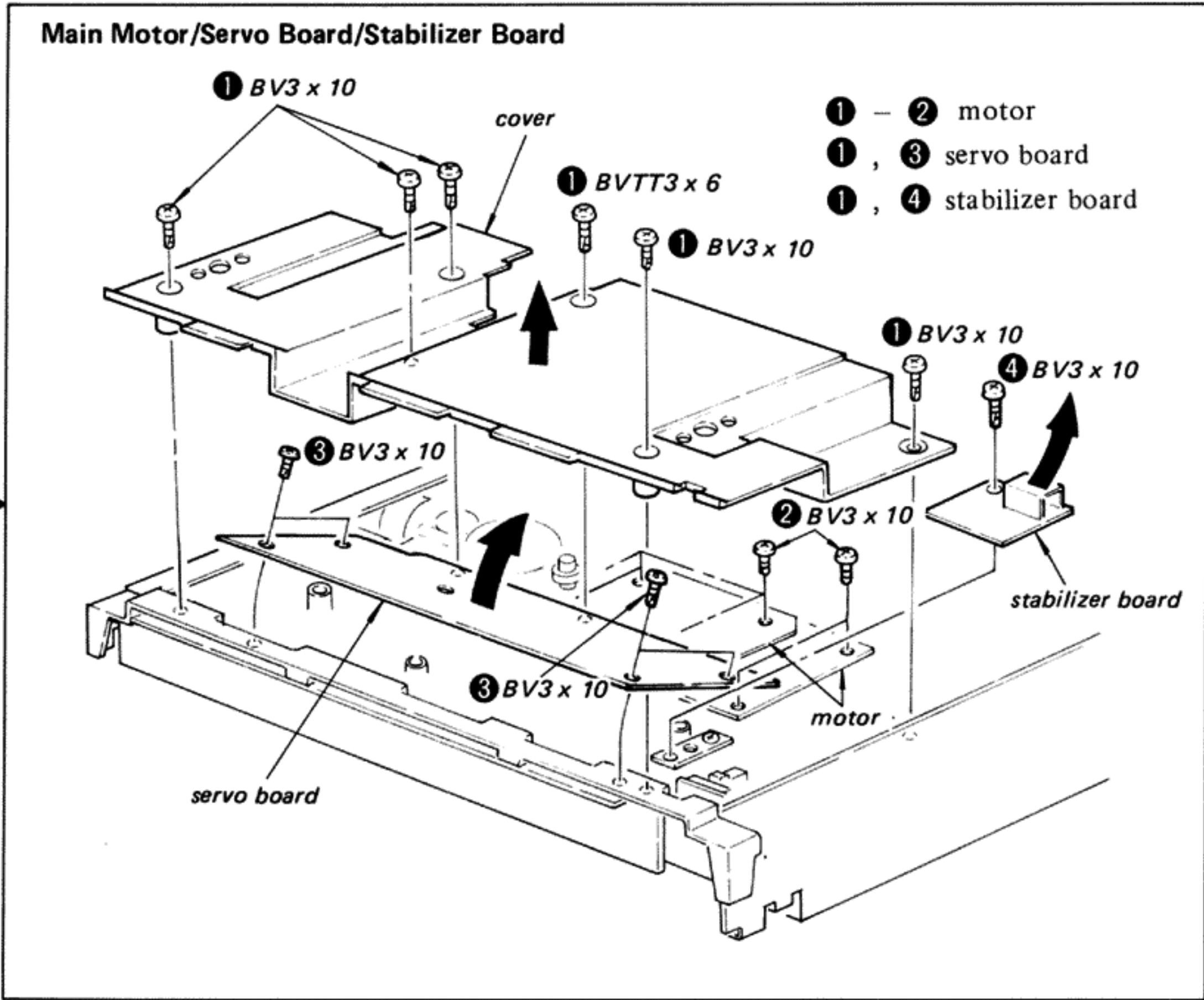

### Phono Board

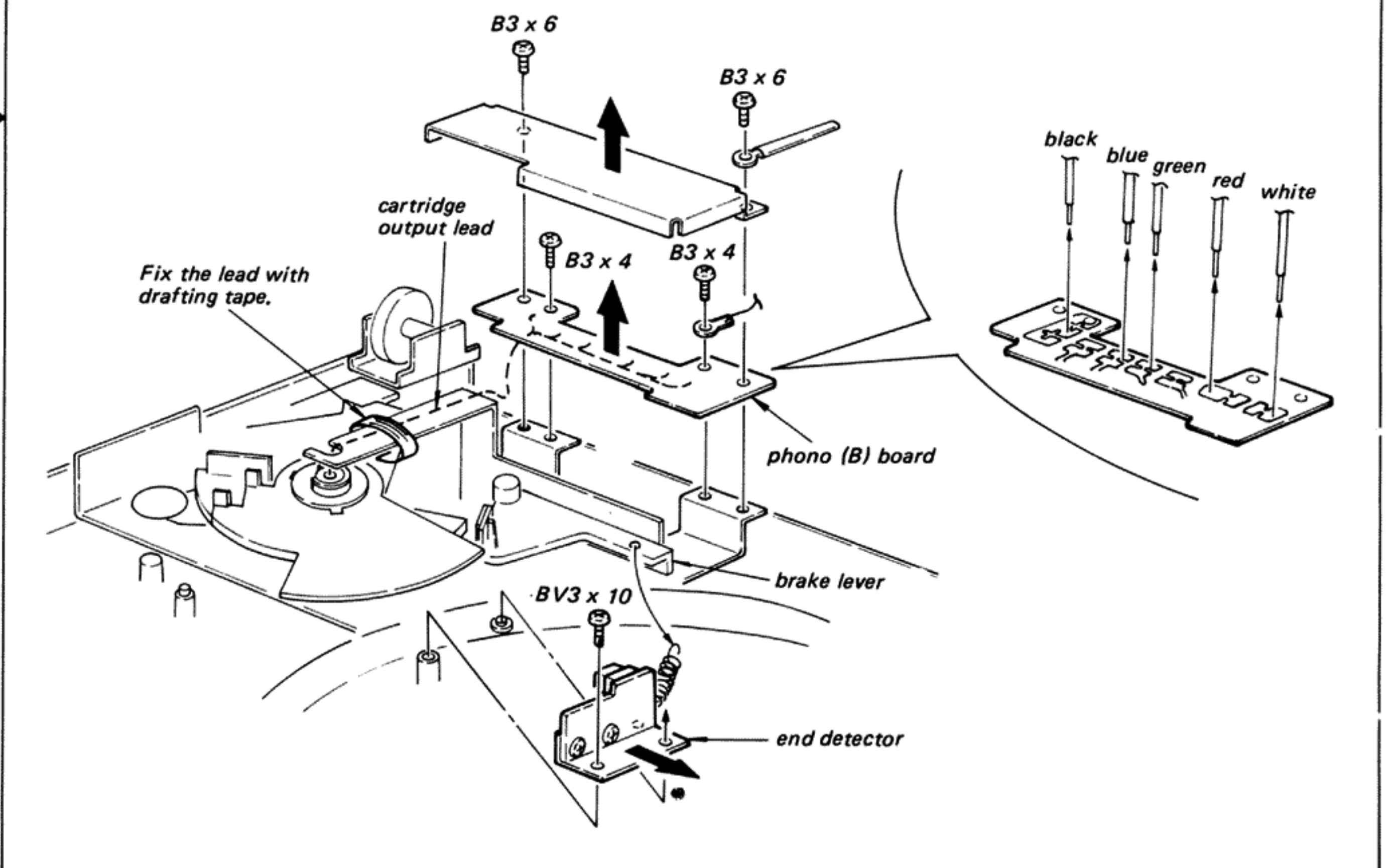



**Gears**

**Note:** Refer to the figure below for maximum diameters of each gear.

Module section: M801—worm wheel (A)—drive gear

Tonearm section: M802—worm wheel (B)—intermediate gear (C)—(B)—(A)—tonearm

It is not necessary to align the angle between gears, but they must engage.

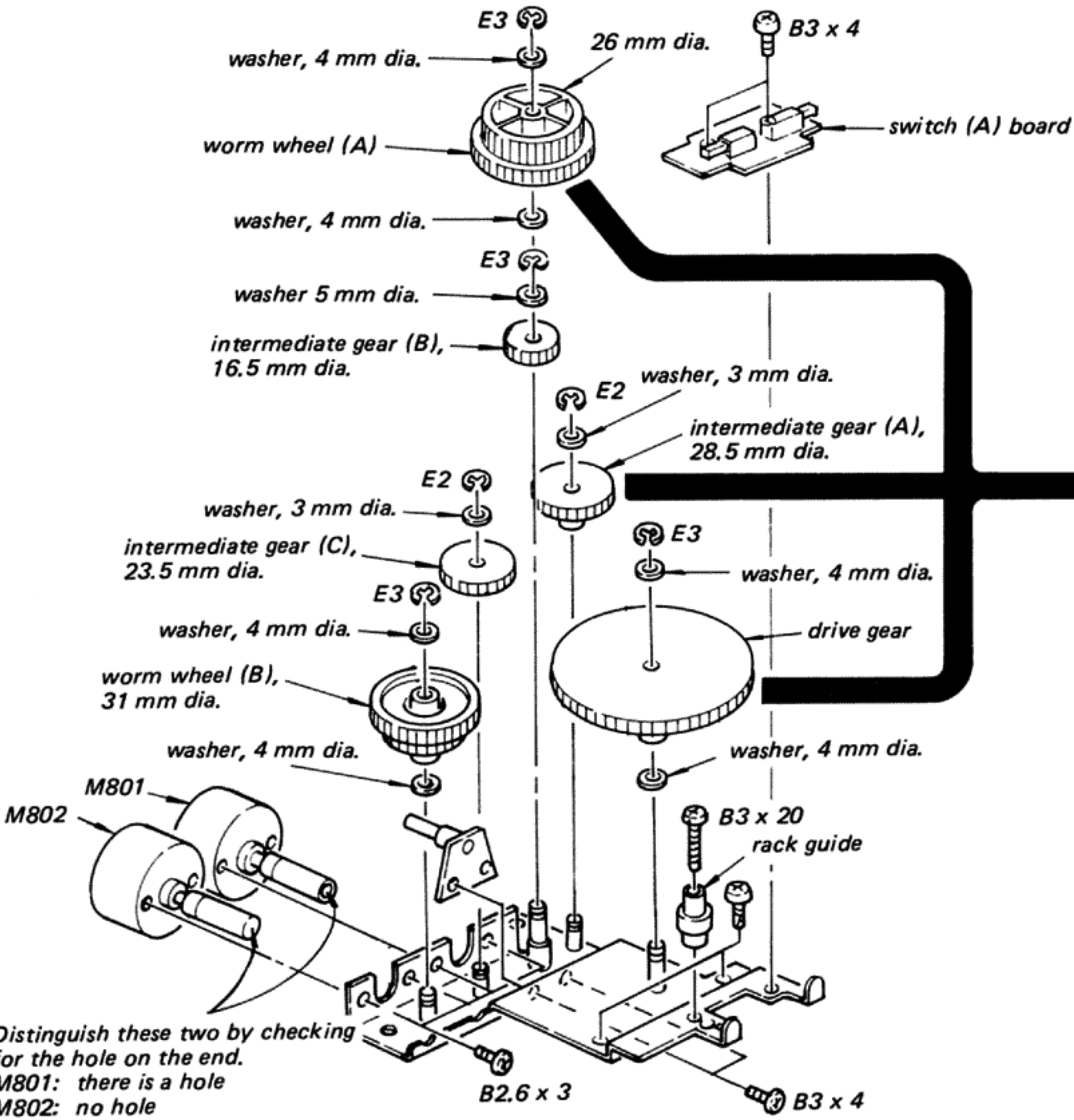

**— Removal of the Block —**

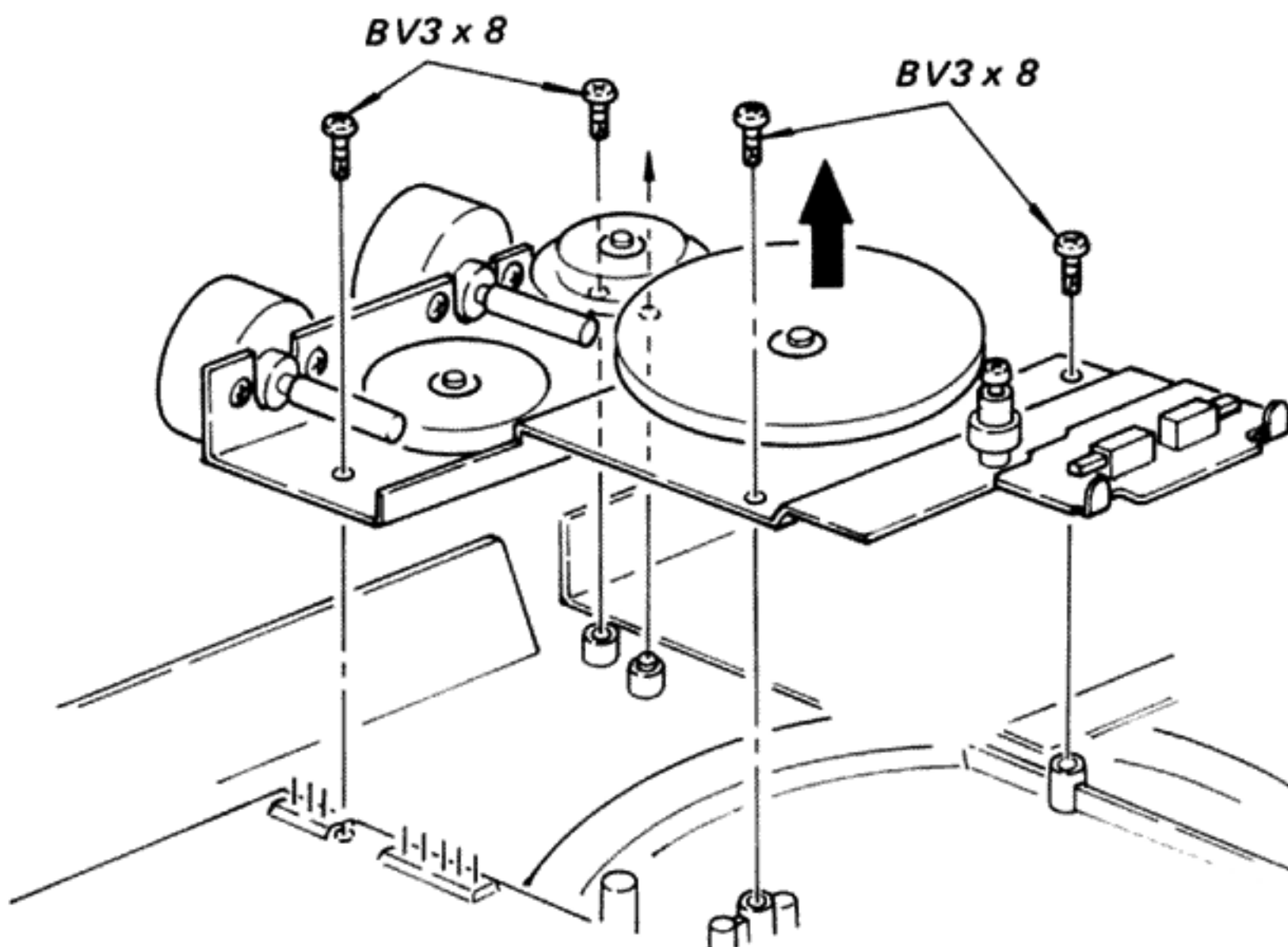

**Brake Drum . . . . .** When installing, position adjustment is necessary.

**Mechanical Chassis**

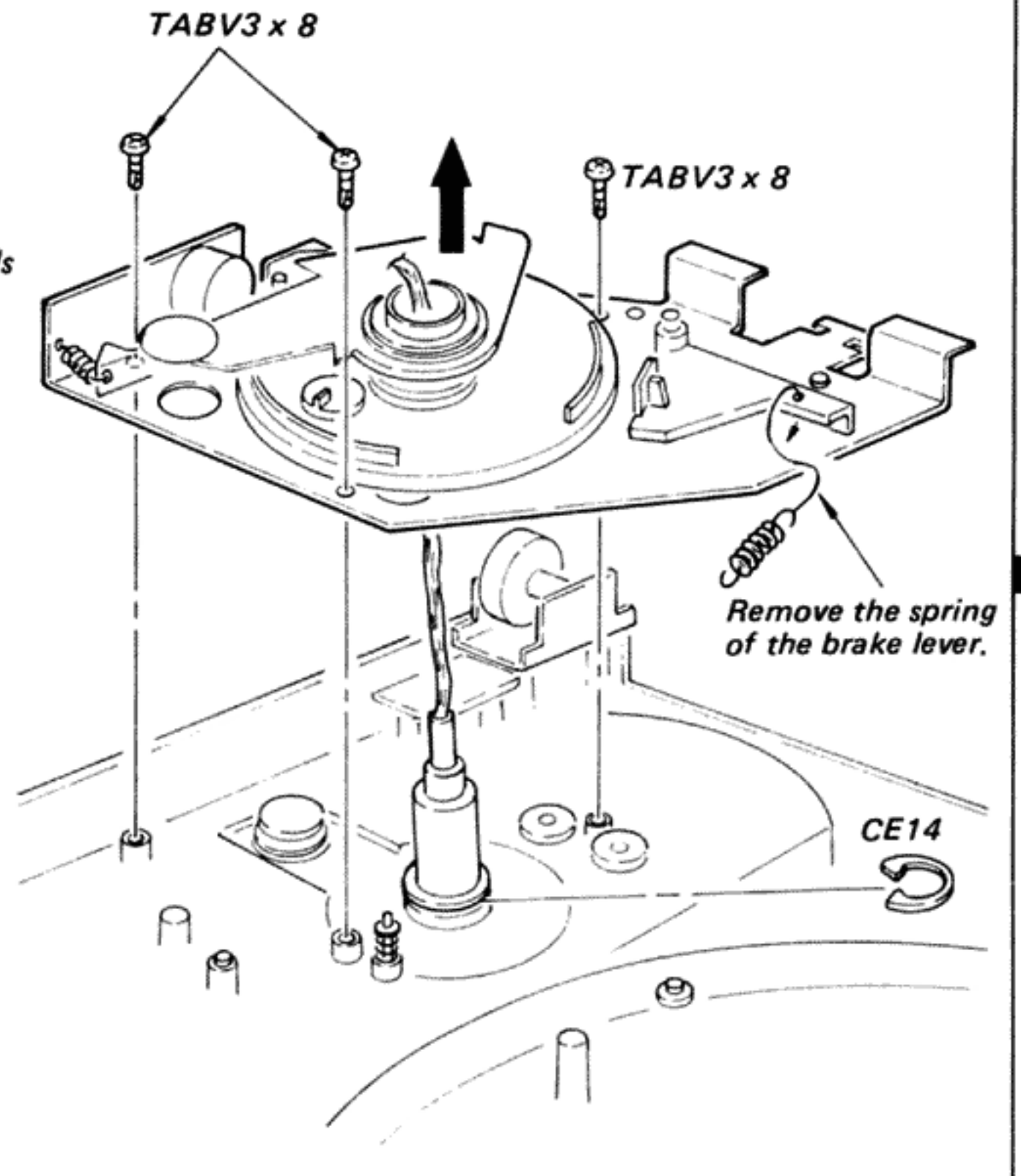
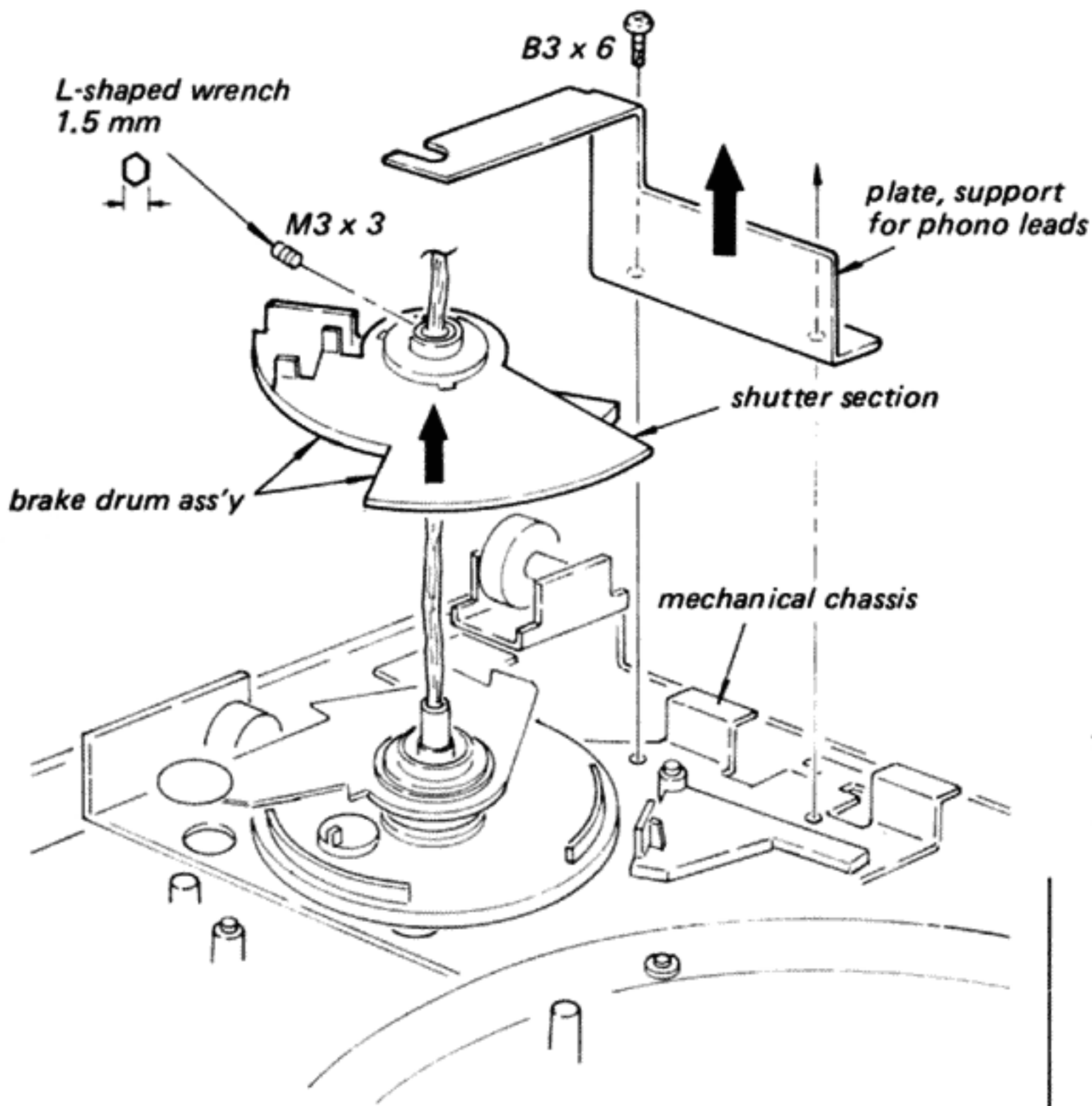

**Tonearm Section**

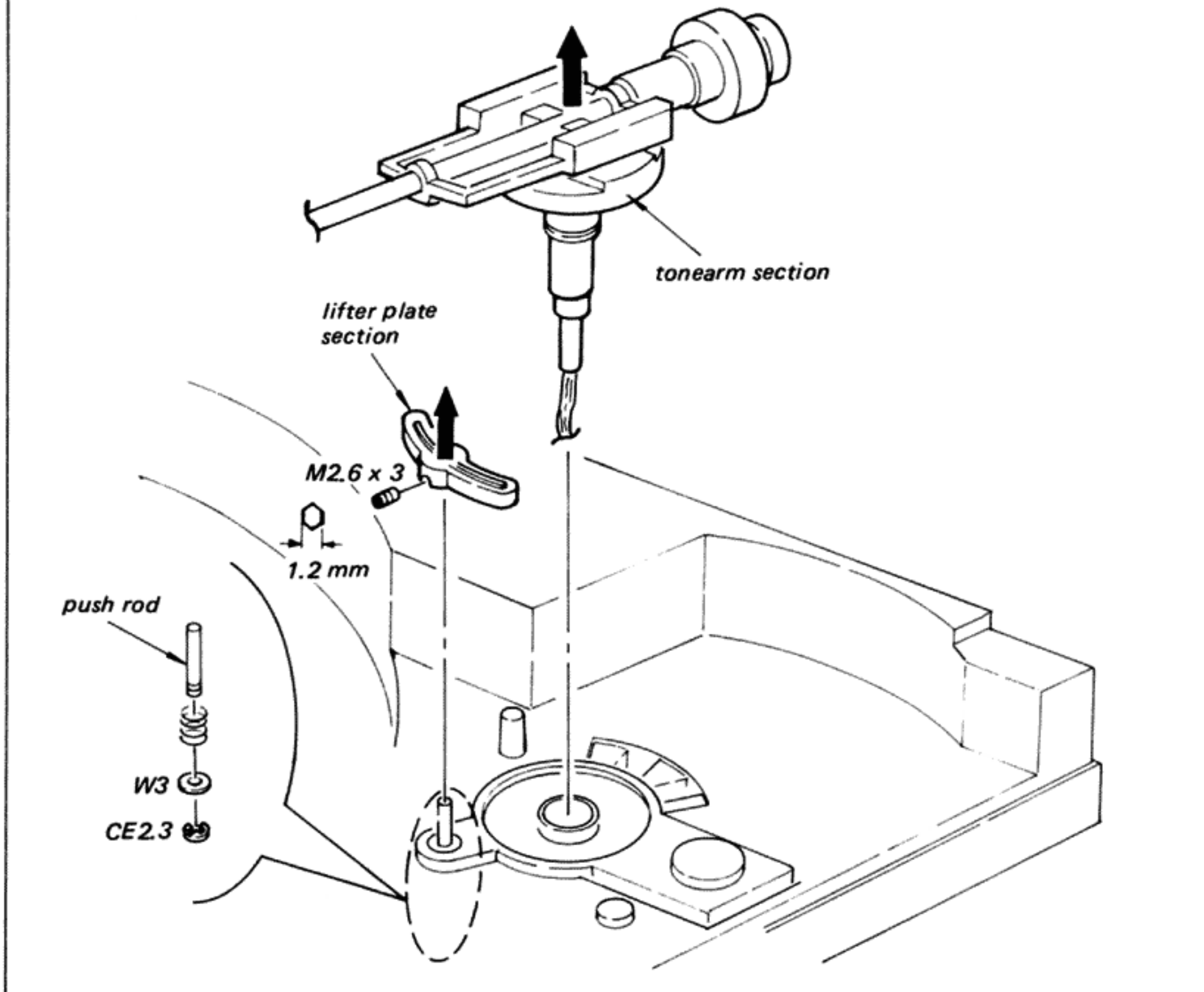

**Control Cam**

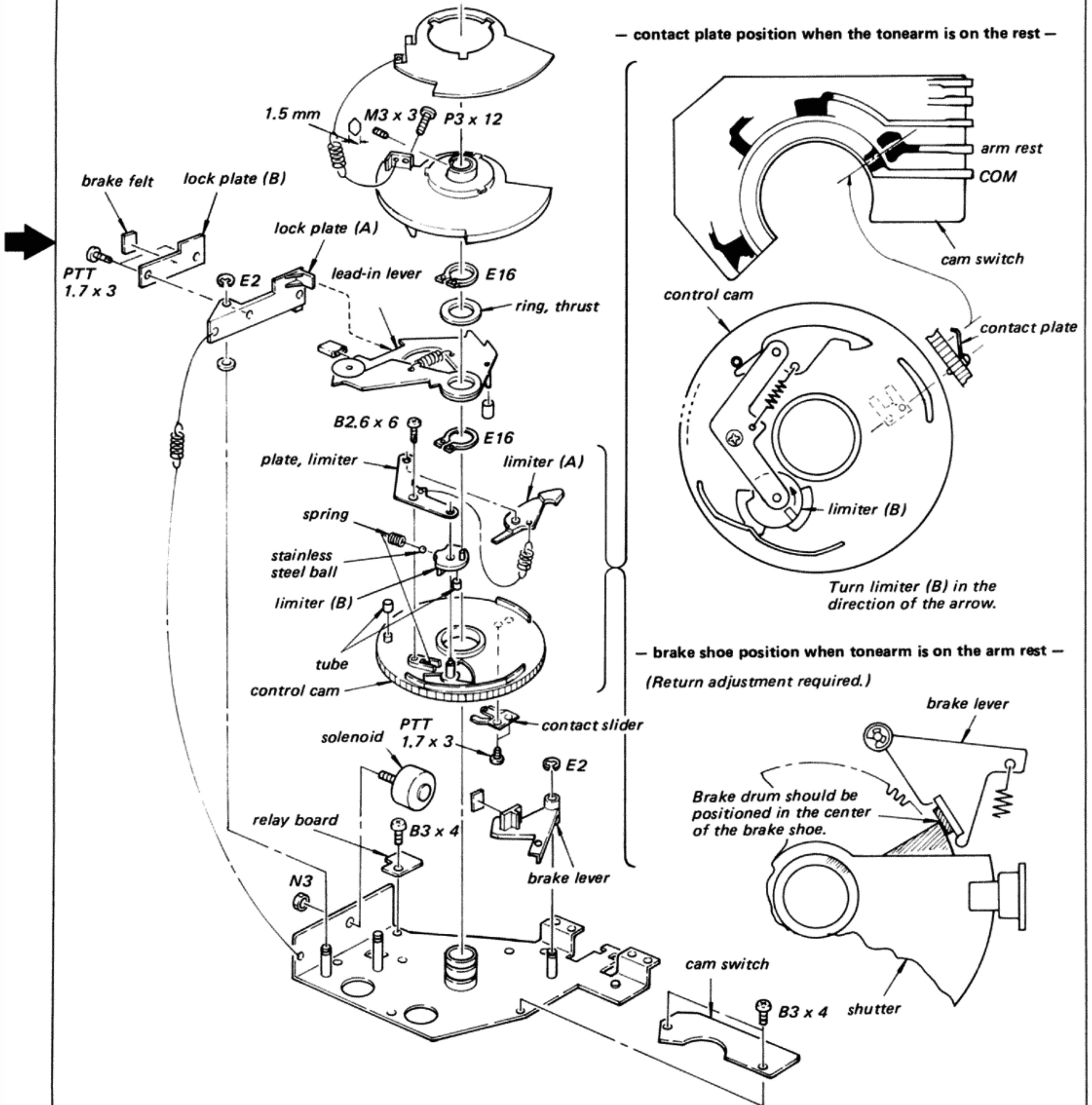



**SECTION 3  
ADJUSTMENTS**

**Shell's Horizontal Balance Adjustment**

Loosen the screw on the neck cylinder so that the clearance **A** is less than 0.5 mm.

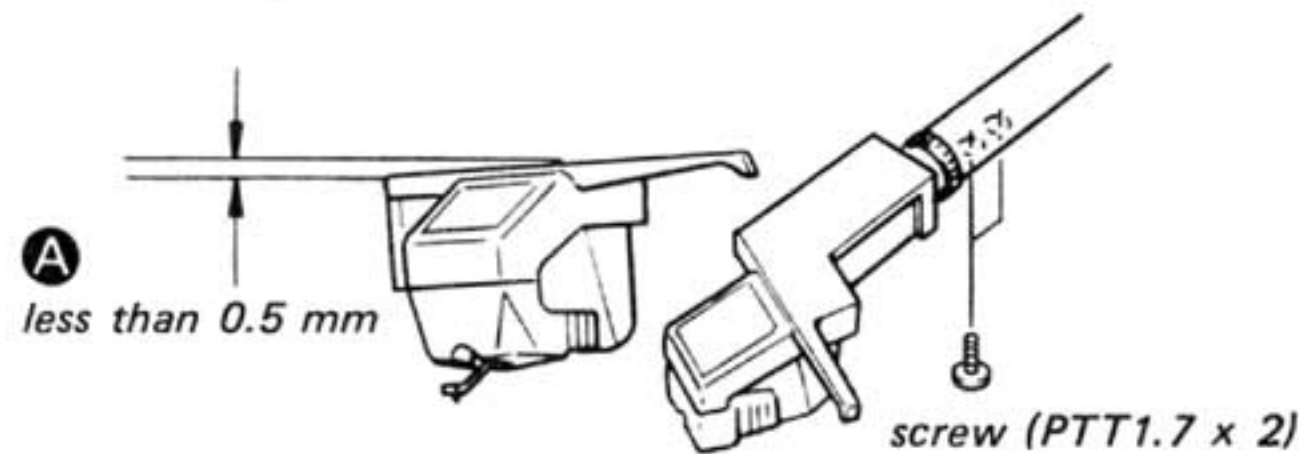

**Stylus Drop-point Adjustment**

1. Remove the rubber cap.
2. Make sure that the stylus drops on the specified point of the test record.  
test record: YFSC-16

Record size	Count of drop-point
30 (12")	7 to 15

3. If necessary, insert a screwdriver into the hole and adjust the drop-point by turning the adjustment screw.

To change the drop-point inward:

Turn the adjustment screw slightly clockwise.  
(The count of the drop-point will be larger.)

To change the drop-point outward:

Turn the adjustment screw slightly counter-clockwise. (The count of the drop-point will be smaller.)

**Note 1:** Once it is properly adjusted with a 30 cm (12") record, the drop-point will be correct for 17 cm (7") records.

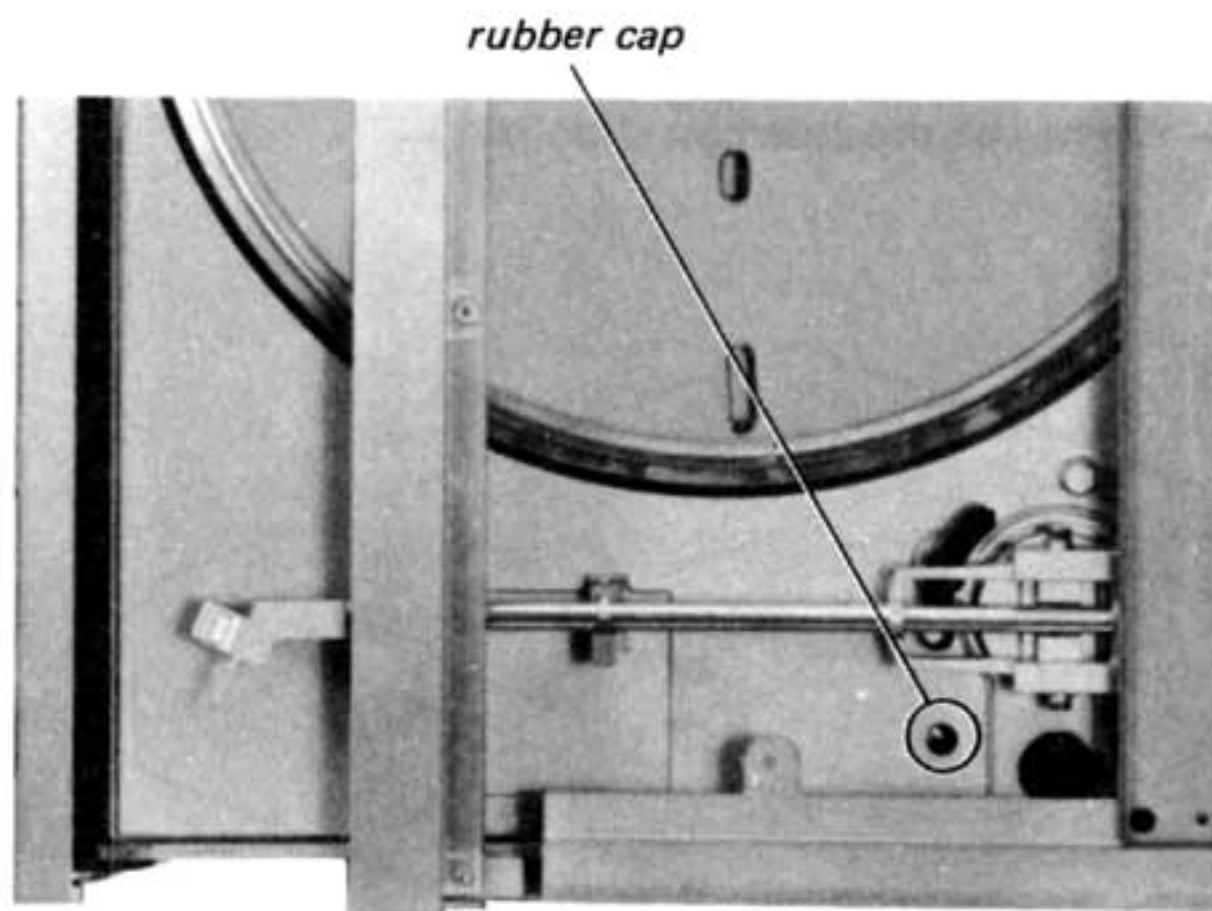

**Reference:** cartridge: XL-20  
stylus force: 1.5 g  
IFC knob: 1.5

**Stylus Height Adjustment**

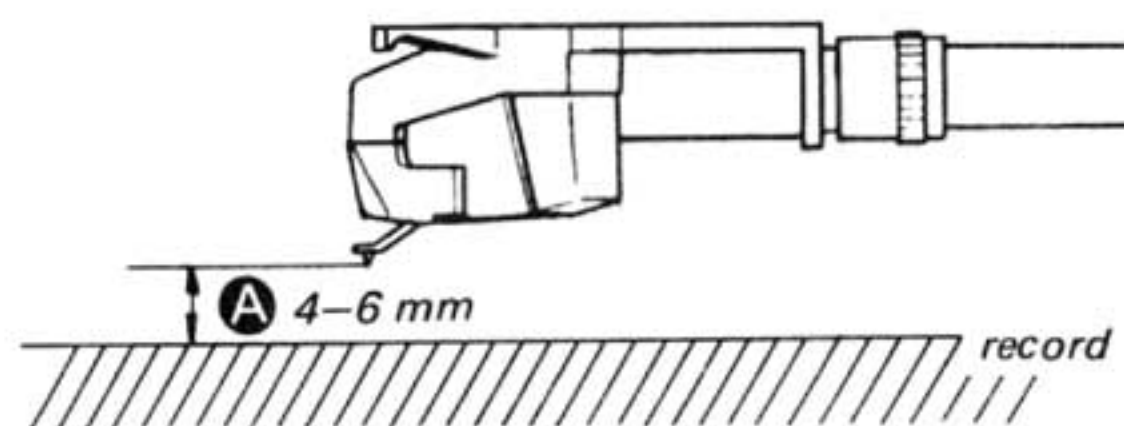

● **During auto play**

1. Put the record on the turntable and press START/STOP button for record play.
2. When the tonearm reaches the end of the record, turn the POWER switch off before it returns to the arm rest and stop the rotation of the turntable by hand.
3. Make sure that the clearance **A** is 4 – 6 mm ( $\frac{5}{32}$  –  $\frac{1}{4}$ "). If necessary, loosen the set screw and adjust the lifter height.

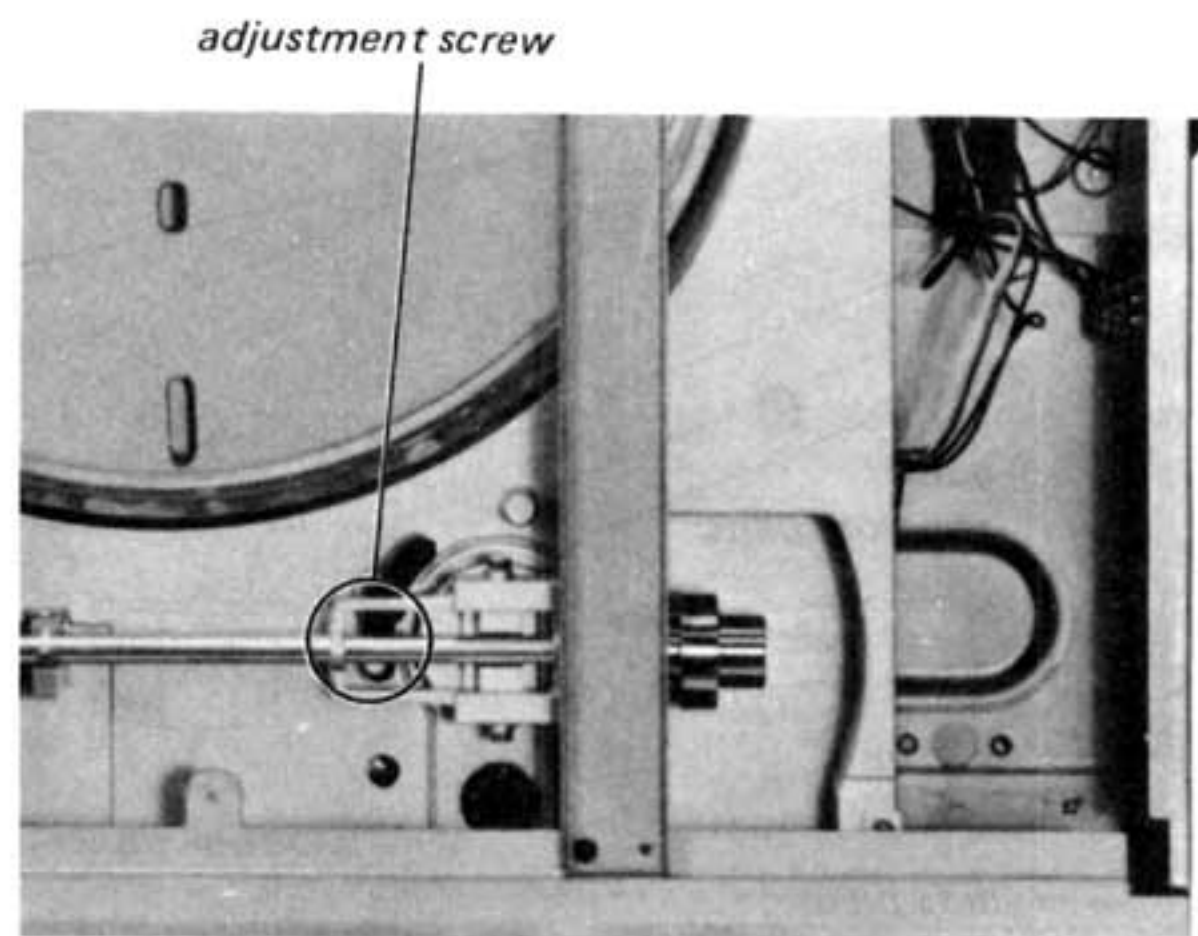

**Note:** Make sure that cartridge does not touch the cabinet when the module opens.

**Brake Drum Position Adjustment**

1. Lock the tonearm on the arm rest.
2. Adjust the position of the brake drum so that the edge is at the center of the brake felt.

*brake drum screw*

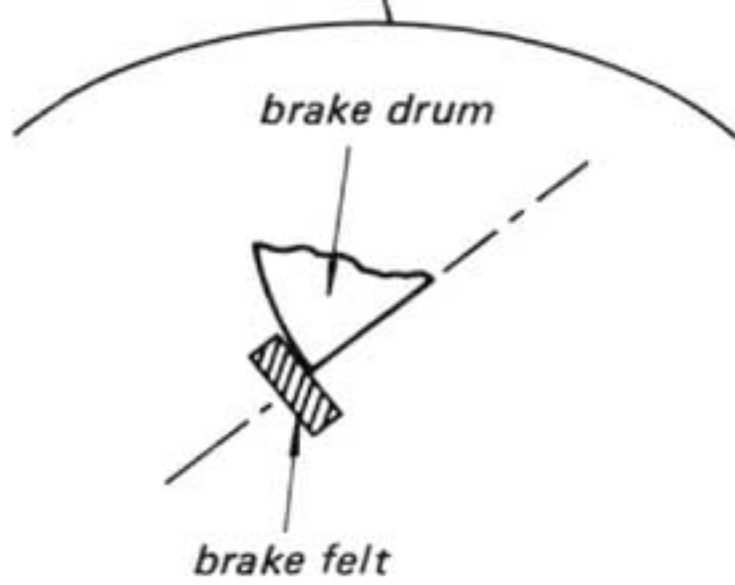
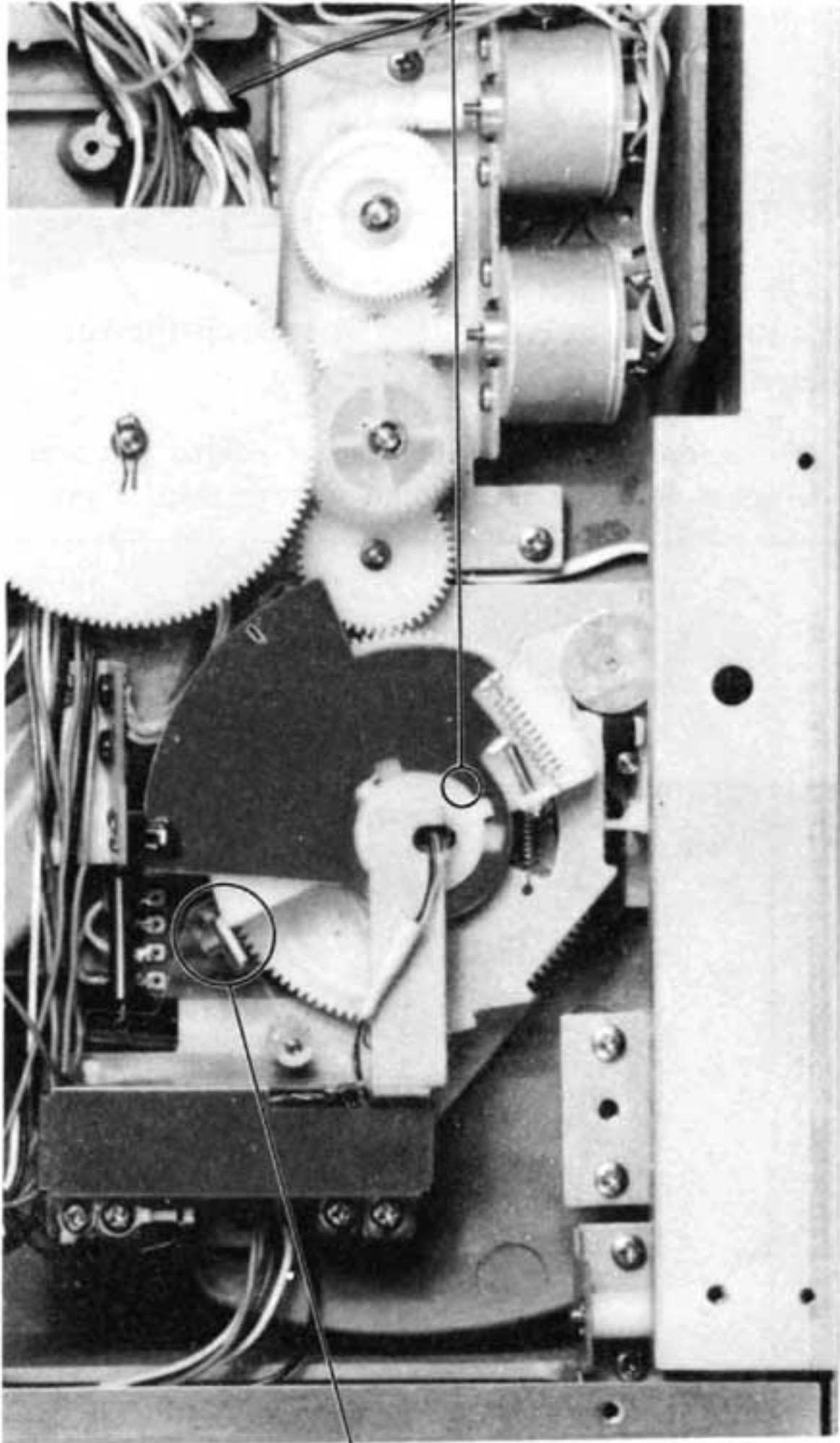

**Automatic Return Position Adjustment**

(Turn the power on.)

1. Set the stylus on the groove of the test record.
2. Turn the adjustment screw so that the tonearm starts to return at count of 15 – 17.

Turning direction	Return-point
clockwise	to the groove
counterclockwise	to the end of the record

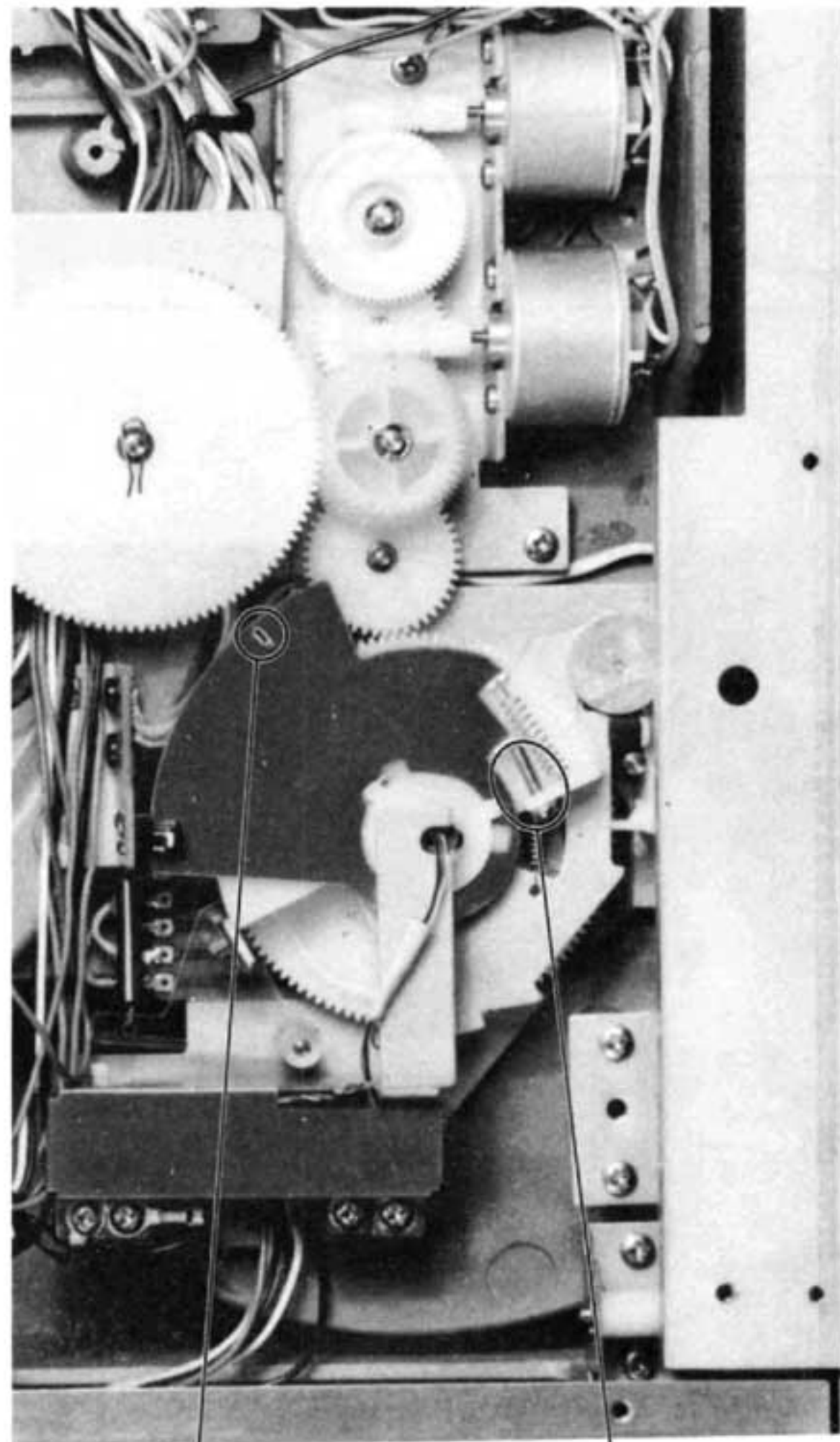

*return slit*

*return position adjustment screw*



— with the turntable removed —

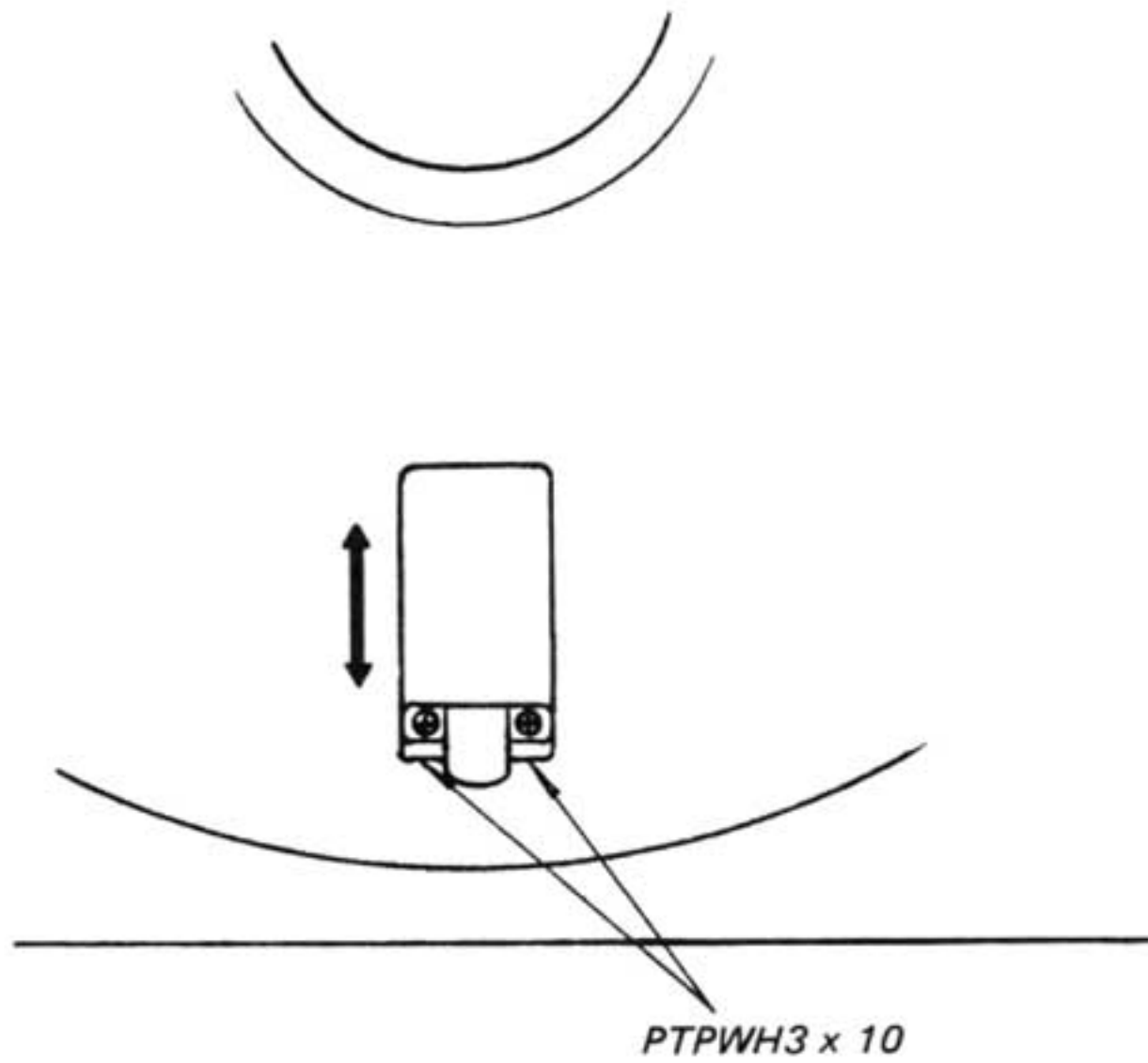

**Speed Detecting Head Output Level Adjustment**

**Setting:**

POWER switch: ON

1. Adjust the position of the head by moving it back and forth after loosening the screw (PTPWH 3 x 10) so that the VTVM reading is more than 30 mV ac at 33 1/3 rpm.

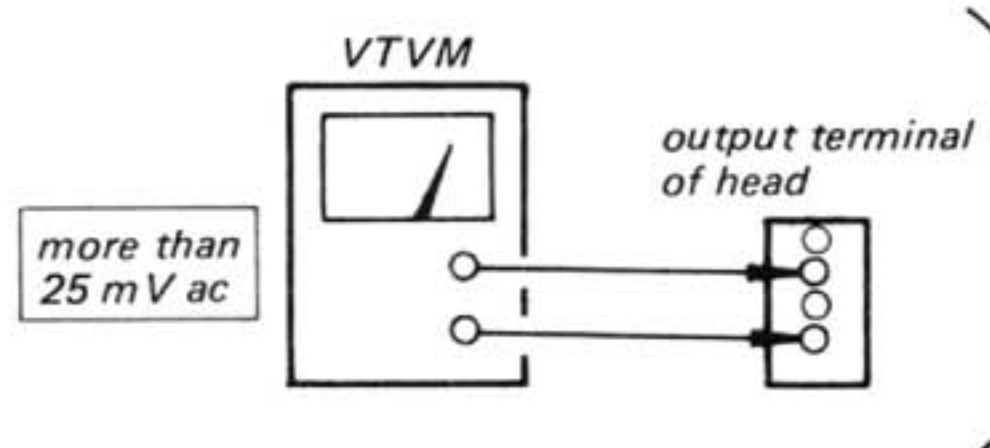

2. Make sure that the head does not touch the turntable and tighten the screws securely.

**Note:** The clearance between the magnet coated rim and the speed-detecting head should be more than 0.3 mm.

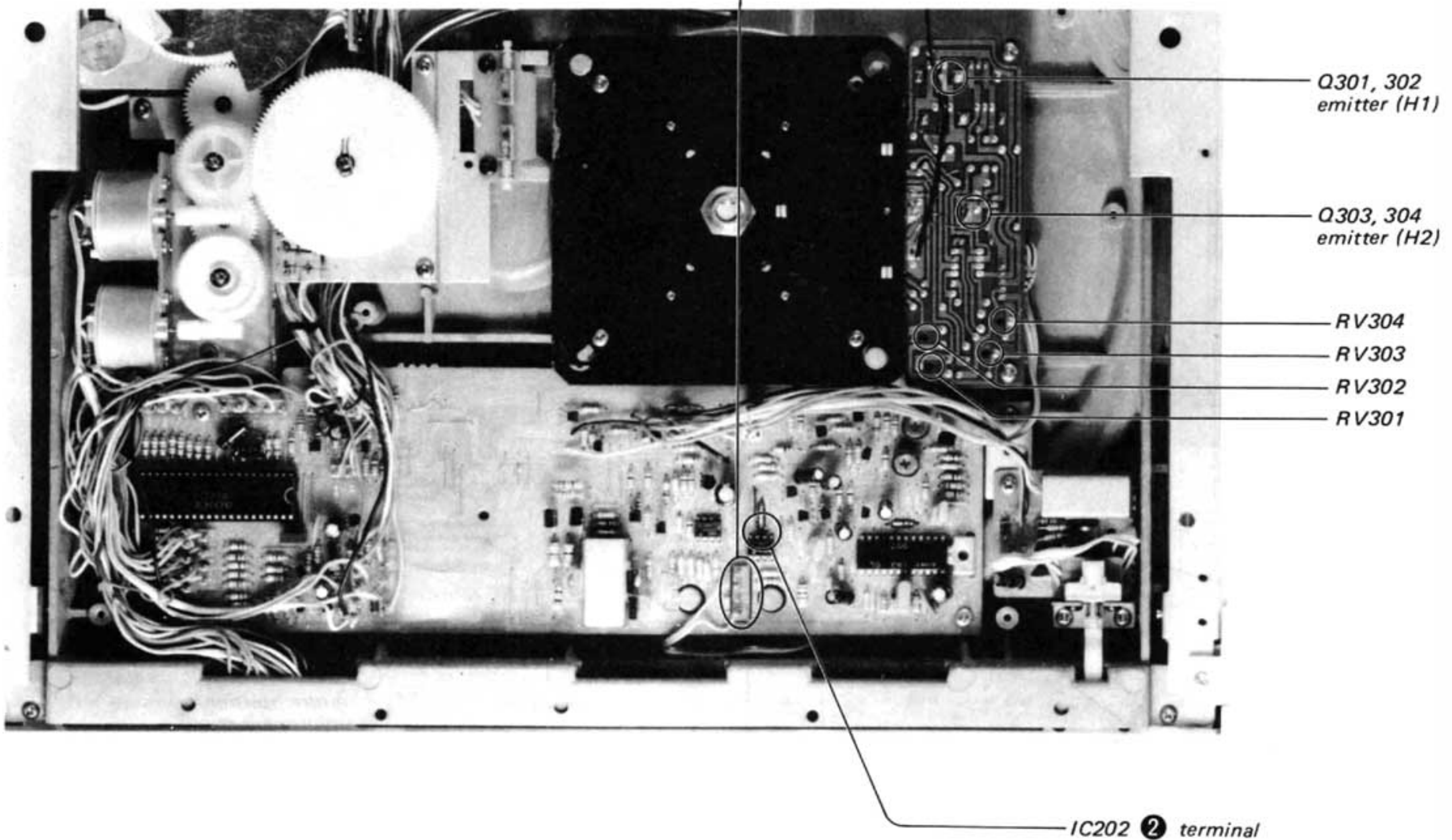



**Gain/Offset Adjustment**

Remove the turntable, turn POWER switch on.

1. Connect dc power supply to IC202 ② via a variable resistor (about 100 kΩ). Adjust the variable resistor so that terminal voltage is 2 V.

**Gain adjustment:**

2. Connect an oscilloscope to Q301, 302 (H1) and adjust RV302 (H1) for 5 Vp-p reading on the oscilloscope.
3. Connect an oscilloscope to Q303, 304 (H2) and adjust RV301 (H2) for 5 Vp-p reading on the oscilloscope.

**Offset adjustment:**

4. Connect VTVM or an oscilloscope to Q301, 302 (H1) and adjust RV303 for 0 V dc VTVM reading or for the waveform on the oscilloscope as shown below.
5. Connect VTVM or an oscilloscope to Q303, 304 (H2) and adjust RV304 for 0 V dc VTVM reading or for the waveform on the oscilloscope as shown below.

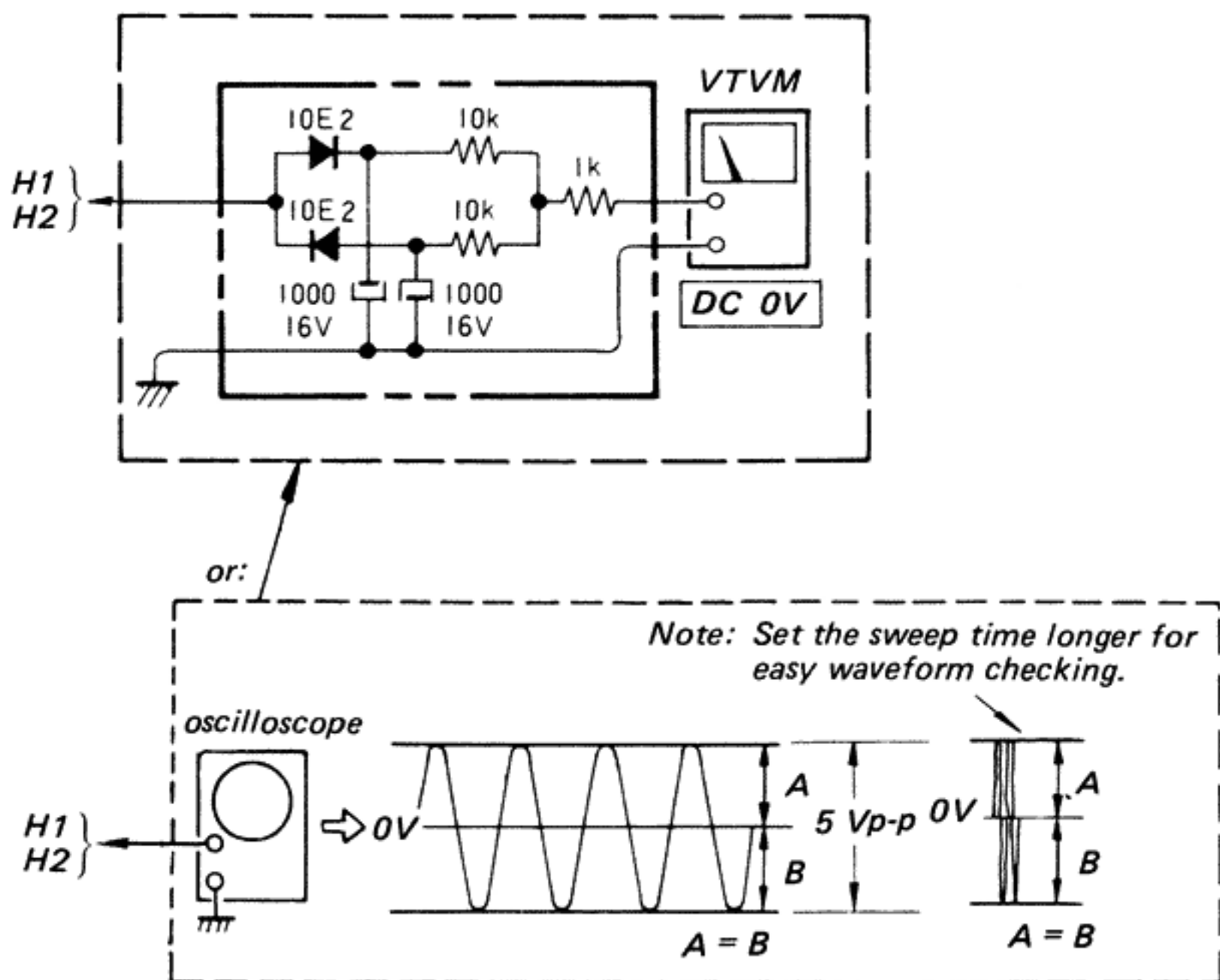

## Speed Adjustment

### Setting:

POWER switch: ON

1. Set the SPEED to 45 rpm.
2. Connect an oscilloscope to IC201 ②
3. Adjust RV202 for specified waveform on the oscilloscope as shown below.

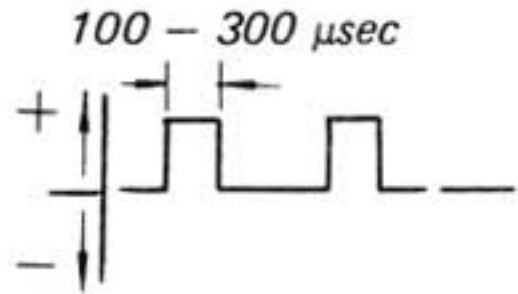

**Note:** The waveform should not appear on the negative side.

4. Set the SPEED to 33 rpm.
5. Adjust RV201 for specified waveform on the oscilloscope as shown below.

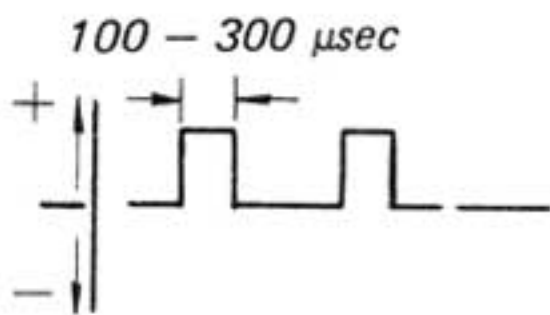

**Note:** The waveform should not appear on the negative side.

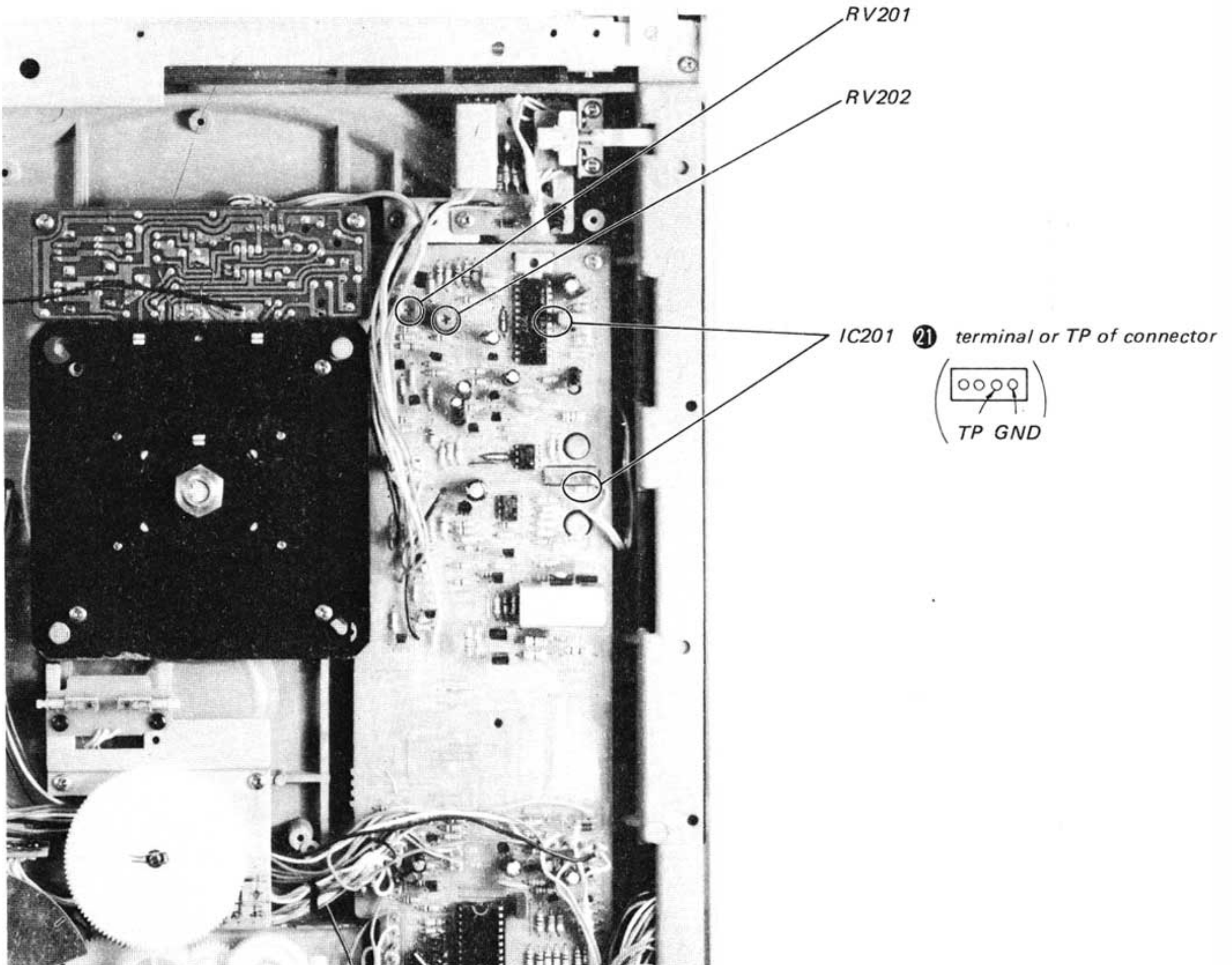



● Reference Photographs

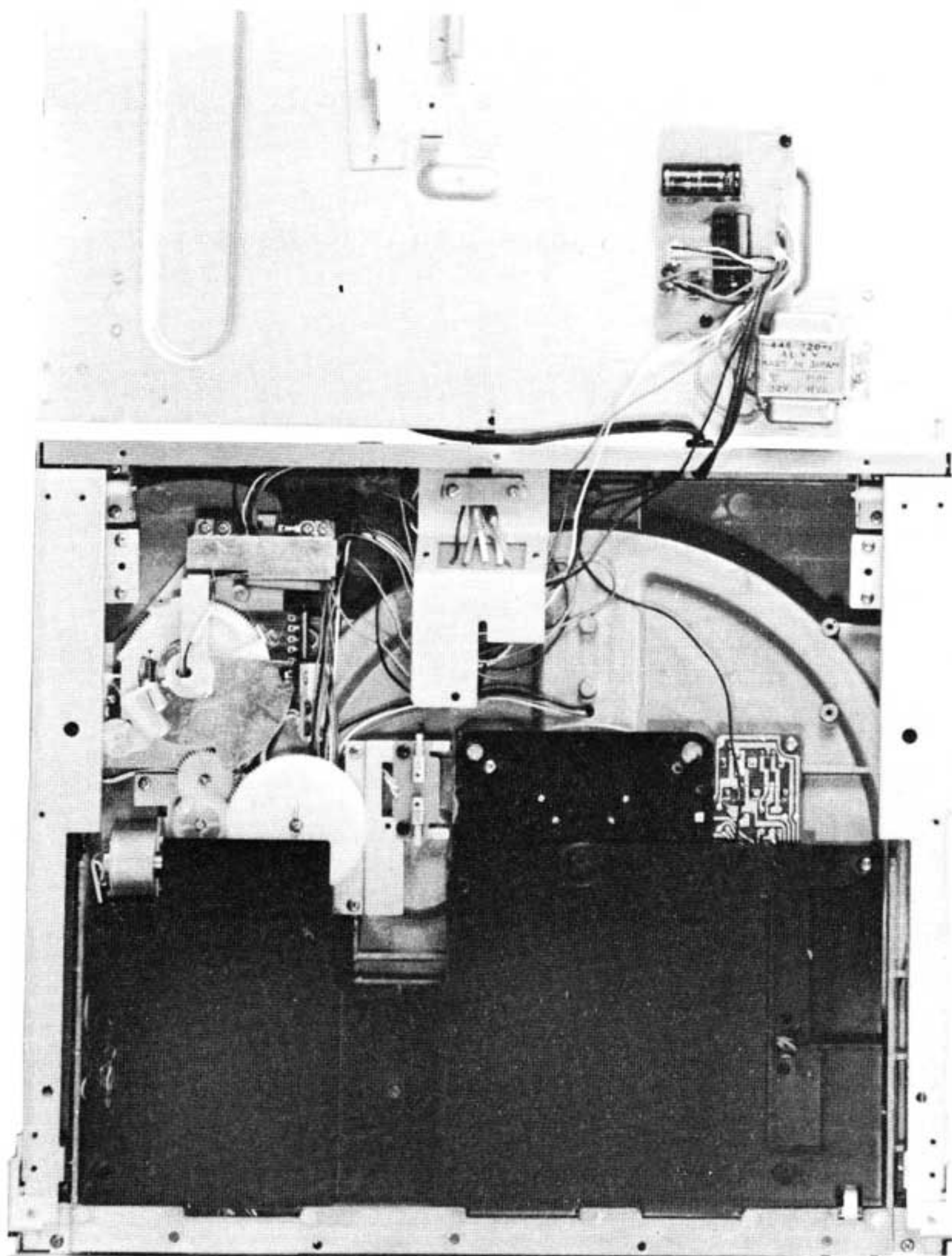
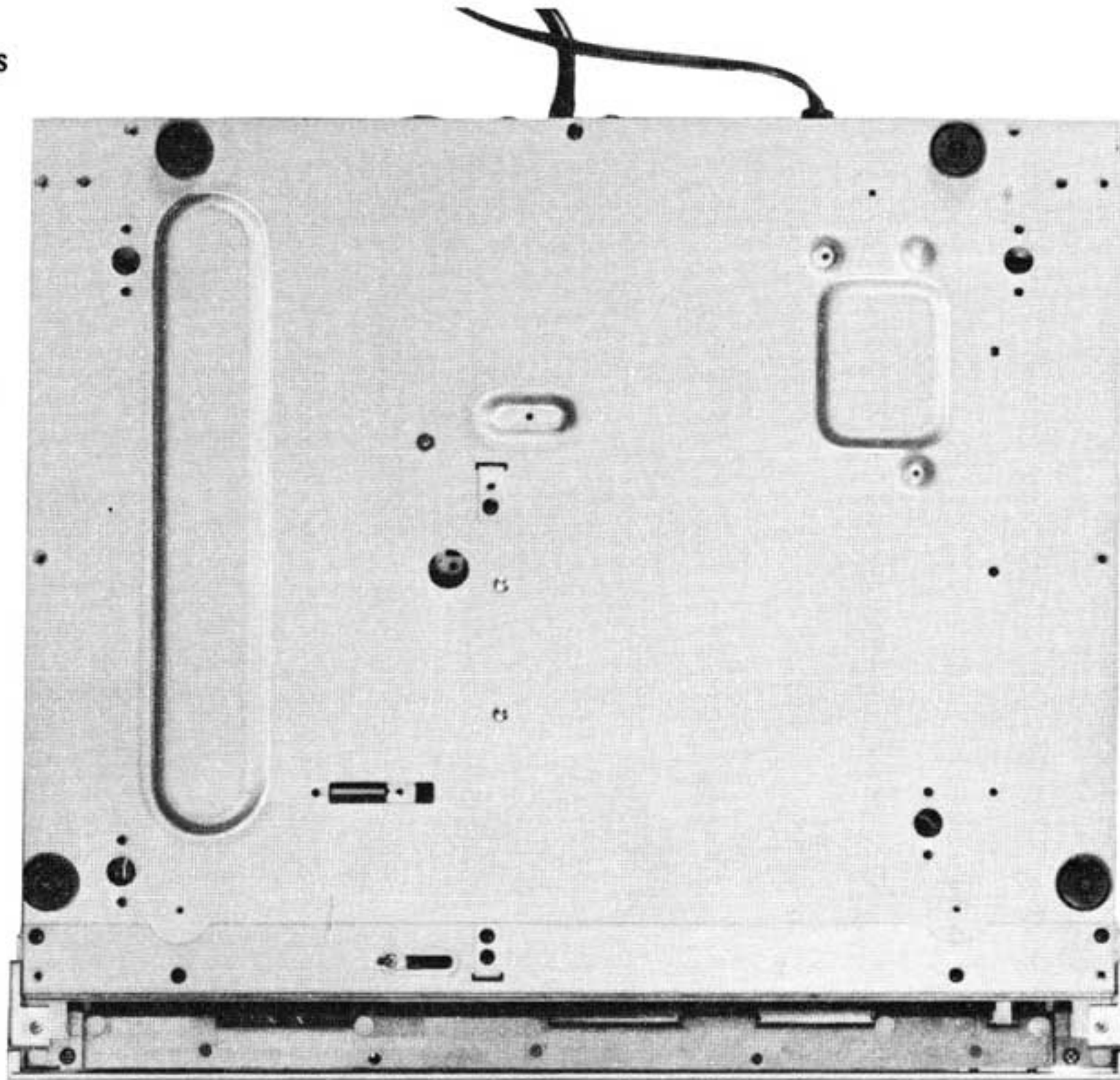



**MEMO**

---

A series of horizontal dotted lines for writing a memo.

SECTION 5  
EXPLODED VIEWS AND PARTS LIST

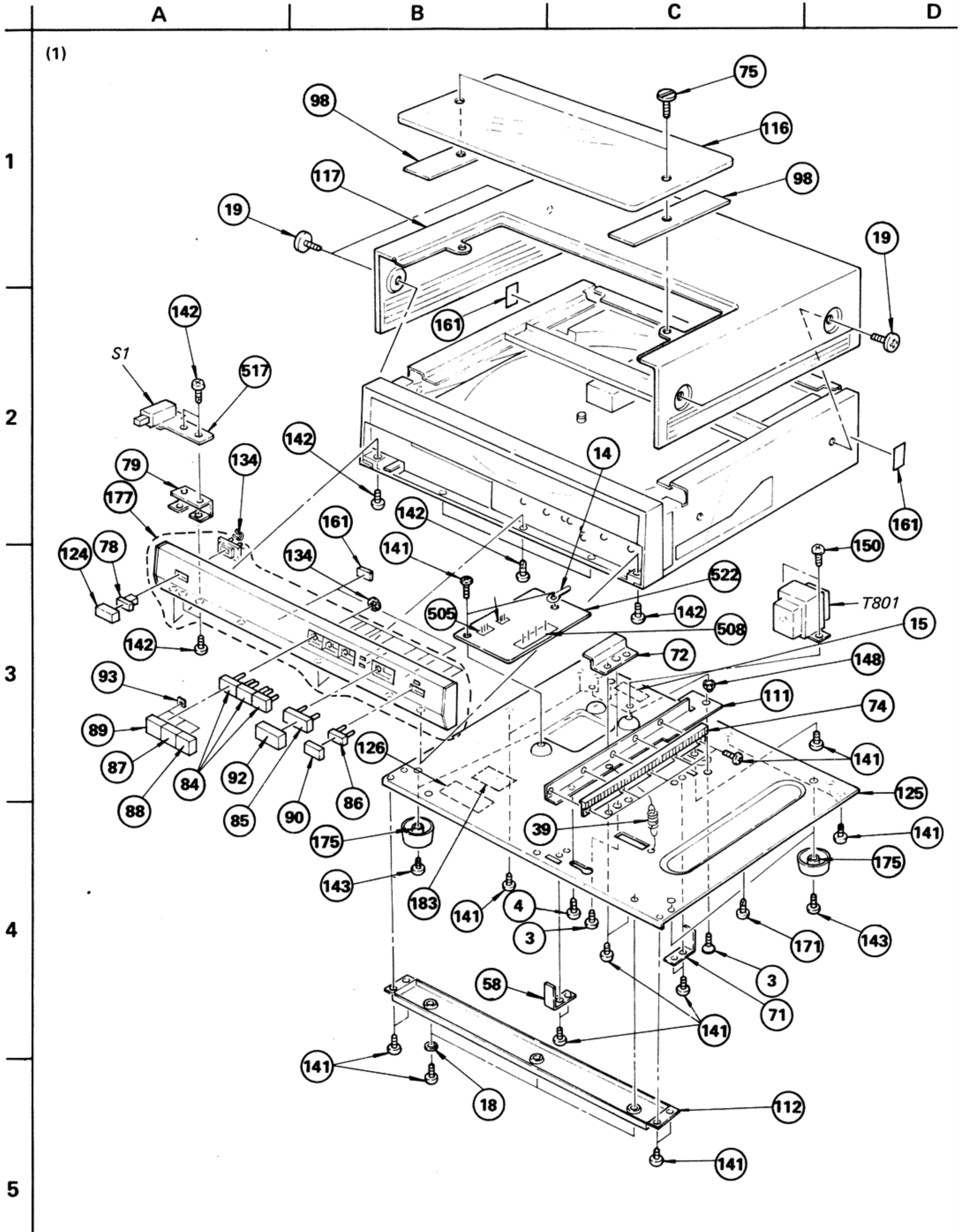

A

B

C

D

(2)

1

2

3

4

5

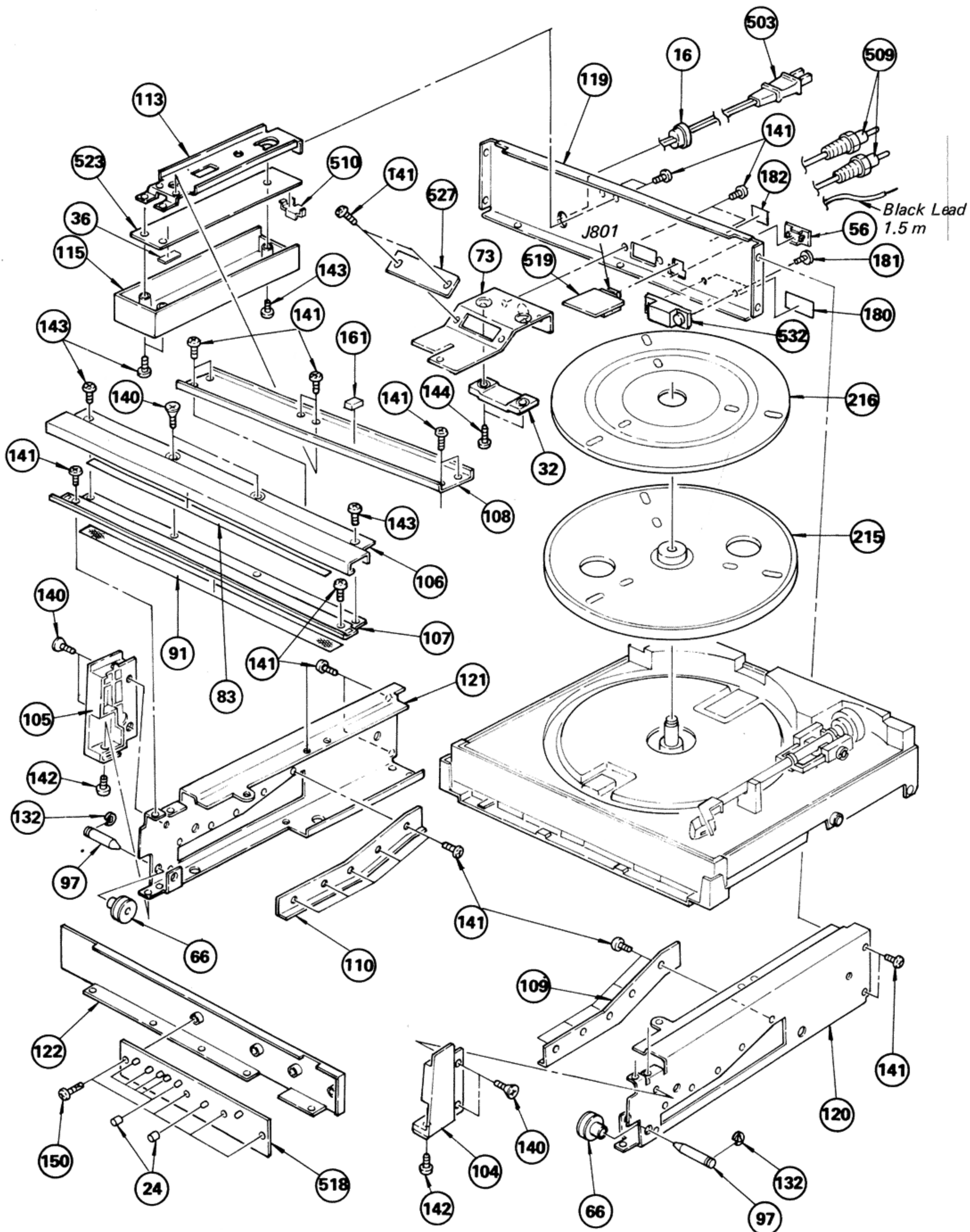





A

B

C

D

(4)

1

2

3

4

5

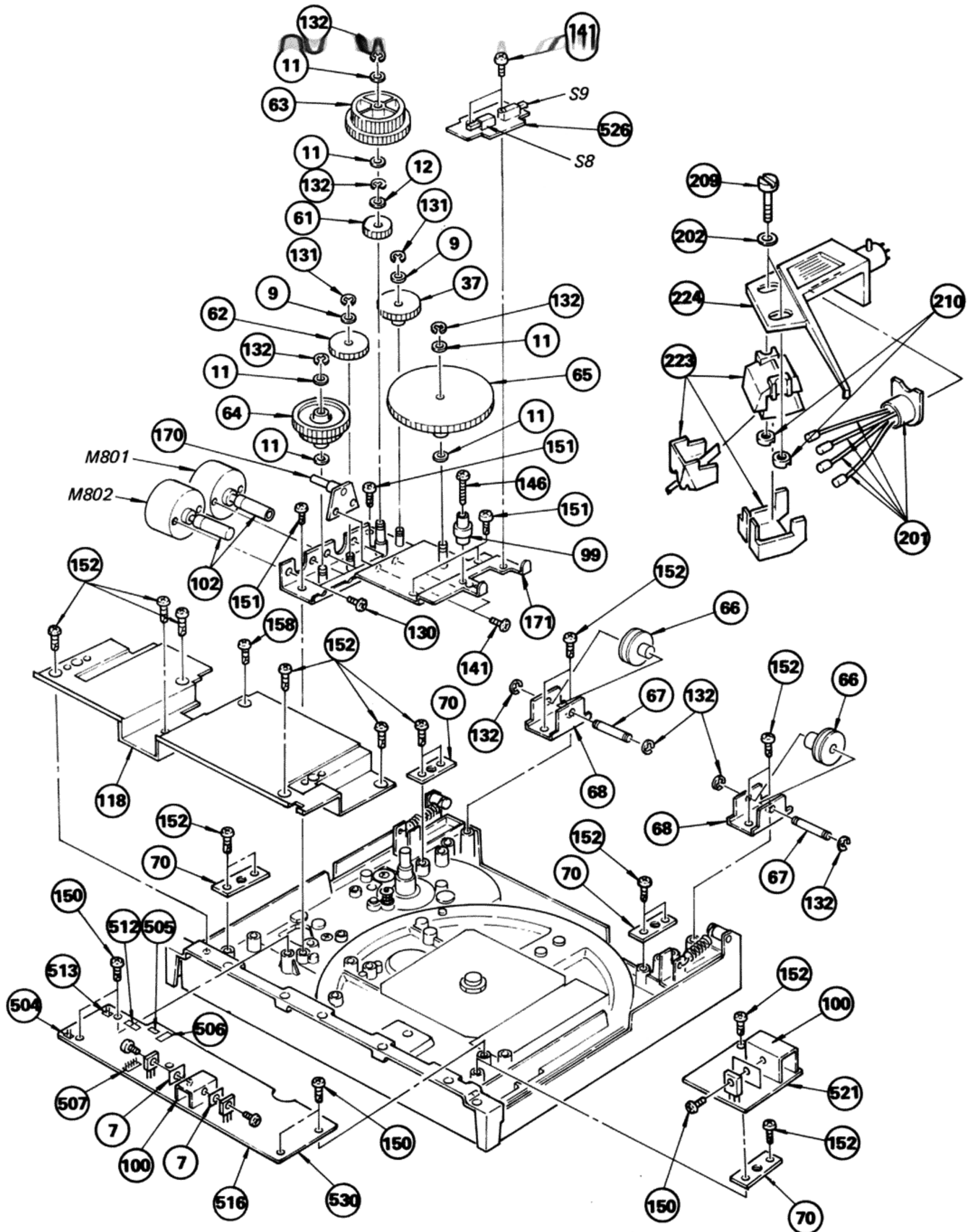



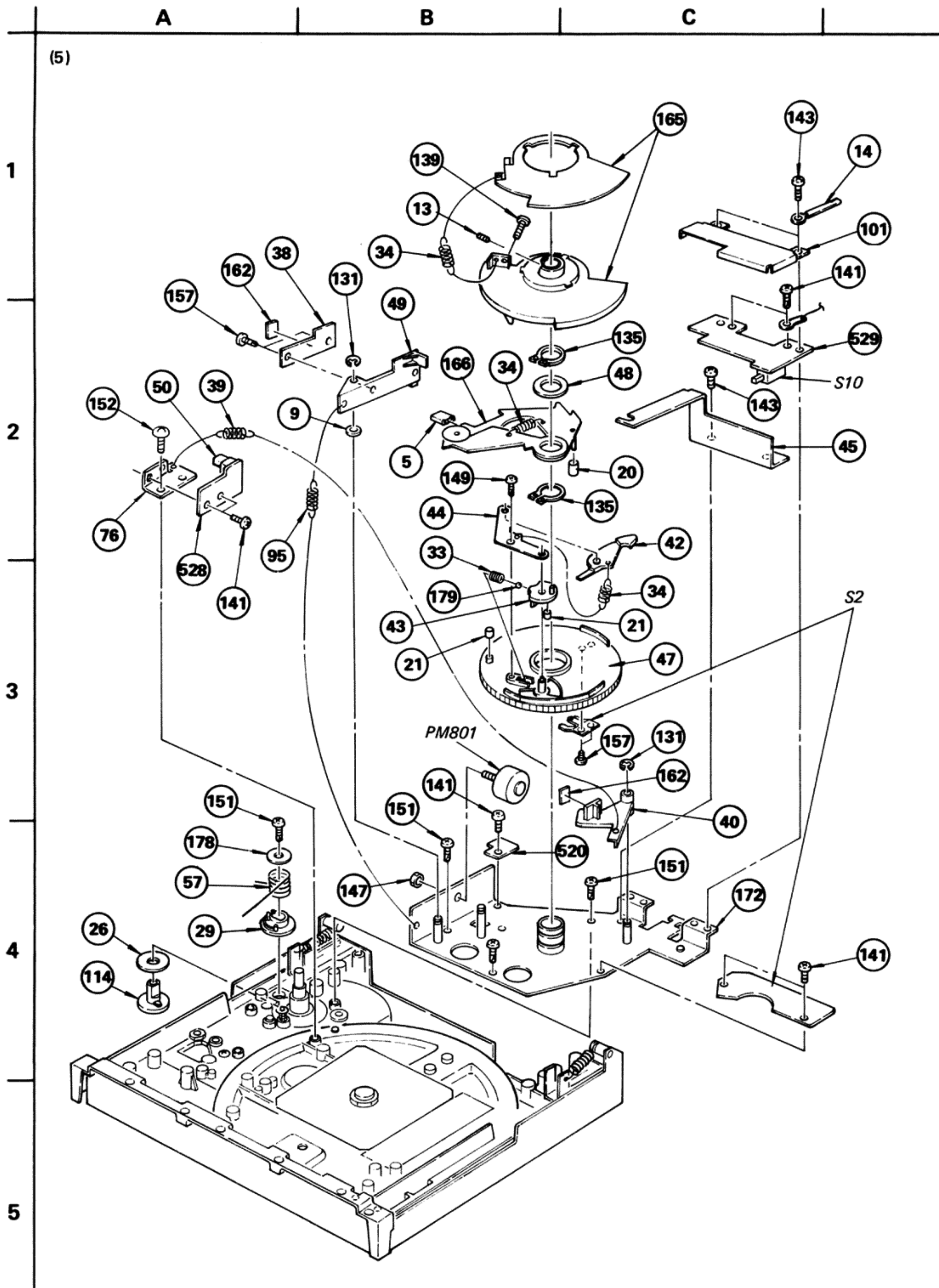



## GENERAL SECTION

No.	Part No.	Description
1	2-203-518-31	SCREW, PIVOT
2	2-203-519-00	NUT
3	♣;3-465-048-00	SHAFT
4	3-486-138-00	SCREW
5	3-537-173-00	CUSHION, CASSETTE-UP
6	♣;3-567-737-00	HEAT SINK
7	3-572-365-01	SHEET (A), INSULATING
8	3-618-078-00	RING, RETAINING, CE TYPE
9	3-701-439-11	WASHER
10	3-701-441-11	WASHER
11	3-701-441-21	WASHER
12	3-701-443-21	WASHER, 5
13	3-701-505-00	SET SCREW, DOUBLE POINT 3X3
14	3-701-822-00	HOLDER, WIRE
15	3-703-396-01	(UK)....LABEL, CAUTION, MAIN
16	3-703-244-00	(AEP,UK,E)...BUSHING, CORD
16	3-701-682-00	(US,Canadian,FL5C)...STOPPER, CORD
17	3-703-454-00	SCREW, TAPPING
18	4-812-554-00	WASHER
19	4-820-330-21	SCREW, BW, PLUS MINUS
20	4-847-035-00	TUBE, ABSORBER
21	4-847-035-21	TUBE, ABSORBER
22	4-847-059-11	CAP, ADJUSTMENT HOLE
23	4-848-650-00	WASHER, TRANSFORMER
24	4-849-559-00	TUBE, ERASE
25	4-852-007-00	RETAINER (A), THRUST
26	4-853-042-00	WASHER
27	4-853-043-00	SPRING (B), GUIDE
28	4-857-642-00	HOLDER, PC BOARD
29	4-858-229-00	CAM, IFC
30	.....	
31	♣;4-858-708-00	FRAME, MOTOR
32	4-861-950-00	HOLDER, PHONO CORD
33	4-862-640-00	SPRING, COMPRESSION
34	4-862-642-00	SPRING, TENSION
35	4-863-604-00	BEARING, PIVOT
36	4-866-397-22	CUSHION, LED
37	4-869-903-00	GEAR (A), MIDWAY
38	♣;4-869-906-00	PLATE (B), LOCK
39	4-869-911-00	SPRING, TENSION
40	4-869-915-00	LEVER, BRAKE
41	.....	
42	4-869-933-00	LIMITER (A)
43	4-869-934-00	LIMITER (B)
44	4-869-935-00	PLATE, LIMITER
45	♣;4-869-936-00	SUPPORT, PHONO LEAD

## GENERAL SECTION

No.	Part No.	Description
46	4-869-946-00	SHAFT, WEIGHT
47	4-869-957-00	CAM, CONTROL
48	4-869-960-00	RETAINER, THRUST
49	4-869-963-00	PLATE, LOCK (A)
50	4-869-965-00	PLATE, SLIT
51	4-869-979-00	PIPE, ARM
52	4-869-980-00	BUSHING, COMPLIANT
53	4-869-992-11	JOINT, PIPE
54	4-869-995-00	WORM
55	4-870-539-00	PLATE, GROUND
56	4-873-331-00	HOLDER, JACK
57	4-874-250-00	SPRING
58	♣;4-879-501-00	PLATE (A), FUNCTION, SWITCH
59	.....	
60	4-879-509-00	ROLLER (A)
61	♣;4-879-512-00	GEAR (B), MIDWAY
62	♣;4-879-513-00	GEAR (C), MIDWAY
63	4-879-514-00	WHEEL (A), WORM
64	4-879-515-00	WHEEL (B), WORM
65	♣;4-879-516-00	GEAR, DRIVING
66	4-879-520-00	ROLLER (B)
67	♣;4-879-521-00	SHAFT, ROLLER (B)
68	♣;4-879-522-00	BRACKET, ROLLER (B)
69	♣;4-879-523-00	BRACKET, LIFTER, PANEL
70	♣;4-879-524-00	PLATE, FIXED
71	♣;4-879-530-00	PLATE, FUNCTION, SWITCH
72	♣;4-879-531-00	PLATE, GUIDE
73	♣;4-879-532-00	BRACKET, PHONO
74	♣;4-879-533-00	RACK
75	4-879-534-00	SCREW, FIXED
76	♣;4-879-535-00	BRACKET, END SENSOR
77	4-879-536-00	NUT, BEARING
78	4-879-539-00	BASE, BUTTON, SWITCH
79	♣;4-879-540-00	BRACKET, SWITCH
80	♣;4-879-541-00	CAP, CENTER
81	4-879-543-00	CASE, ROD, PUSH
82	4-879-544-00	PLATE, ORNAMENTAL, REST
83	4-879-545-00	PROTECTOR (A)
84	4-879-549-00	BASE (B), BUTTON
85	4-879-550-00	BASE (C), BUTTON
86	4-879-551-00	BASE (D), BUTTON
87	4-879-552-00	BUTTON, REPEAT
88	4-879-553-00	BUTTON, SPEED
89	4-879-554-00	BUTTON, LIFTER
90	4-879-555-00	BUTTON, OPEN

### NOTE:

- Items with no part number and no description are not stocked because they are seldom required for routine service.
- Items marked "♣" are not stocked since they are seldom required for routine service. Some delay should be anticipated when ordering these items.
- Due to standardization, parts with part numbers (Δ-ΔΔΔ-ΔΔΔ-XX or Δ-ΔΔΔΔ-ΔΔΔ-X) may be different from those used in the set.

### CAPACITORS:

- All capacitors are in μF. Common capacitors are omitted. Refer to the following lists for their part numbers.  
MF:μF, PF:μμF.

### RESISTORS

- All resistors are in ohms. Common 1/4W, 1/8W and 1/16W carbon resistors are omitted. Refer to the following lists for their part numbers.

- F : nonflammable

### COILS

- MMH : mH, UH : μH

The components identified by shading and mark  are critical for safety. Replace only with part number specified.

Les composants identifiés par une trame et une marque  sont critiques pour la sécurité. Ne les remplacer que par une pièce portant le numéro spécifié.

### SEMICONDUCTORS

- In each case, U : μ, for example:  
UA...: μA..., UPA...: μPA..., UPC...: μPC,  
UPD...: μPD...

## GENERAL SECTION

No.	Part No.	Description
91	4-879-559-00	PROTECTOR (B)
92	4-879-560-00	BUTTON, START/STOP
93	4-879-556-00	COVER (A), LED
94	4-879-563-00	SPRING, COMPRESSION
95	4-879-564-00	SPRING, TENSION
96	4-879-565-00	SPRING, TENSION
97	♣;4-879-566-00	SHAFT (C), ROLLER
98	4-879-567-00	SHEET, PROTECTION, GLASS
99	♣;4-879-568-00	GUIDE, RACK
100	♣;4-879-569-00	HEAT SINK
101	♣;4-879-570-00	CASE, SHIELD
102	4-879-571-00	WORM
103	4-879-574-00	PANEL, FRONT
104	4-879-575-00	ESCUTCHEON (RIGHT), SIDE PLATE
105	4-879-576-00	ESCUTCHEON (LEFT), SIDE PLATE
106	4-879-577-00	PANEL, TOP
107	♣;4-879-578-00	REINFORCEMENT (A)
108	♣;4-879-579-00	REINFORCEMENT (B)
109	♣;4-879-580-00	CAM (RIGHT), FUNCTION, PANEL
110	♣;4-879-581-00	CAM (LEFT), FUNCTION, PANEL
111	♣;4-879-584-00	BRACKET, RACK
112	♣;4-879-585-00	REINFORCEMENT (D)
113	♣;4-879-586-00	REINFORCEMENT (C)
114	4-879-587-00	KNOB, IFC
115	4-879-589-00	COVER, SENSOR, SIZE
116	4-879-590-00	GLASS, FRONT
117	4-879-591-00	PLATE, TOP
118	♣;4-879-592-01	COVER
119	♣;4-879-593-00	(US,Canadian,FL5C)..PLATE, REAR
119	♣;4-879-593-11	(AEP,UK).....PLATE, REAR
119	♣;4-879-593-21	(E).....PLATE, REAR
120	♣;4-879-594-00	PLATE (RIGHT), SIDE
121	♣;4-879-595-00	PLATE (LEFT), SIDE
122	♣;4-879-598-00	COVER, PANEL
123	♣;4-879-600-00	FRAME
124	4-879-602-00	BUTTON, POWER
125	4-879-603-00	PLATE, BOTTOM
126	4-879-615-11	LABEL, CAUTION, SERVICE
127	.....	
128	.....	
129	7-621-734-09	SET-SCT, HEX. 2.6X3
130	7-621-775-00	SCREW +B 2.6X3
131	7-624-104-04	STOP RING 2.0, TYPE -E
132	7-624-106-04	STOP RING 3.0, TYPE -E
133	7-624-133-84	STOP RING 14, TYPE-CE
134	7-624-190-81	STOP RING 2, TYPE-CS
135	7-624-197-31	STOP RING 16, TYPE-C

## GENERAL SECTION

No.	Part No.	Description
136	7-671-155-01	STEEL BALL 3.0
137	7-682-147-01	SCREW +P 3X6
138	7-682-147-13	SCREW +P 3X6
139	7-682-150-13	SCREW +P 3X12
140	7-682-245-04	SCREW +K 3X4
141	7-682-545-09	SCREW +B 3X4
142	7-682-546-04	SCREW +B 3X5
143	7-682-547-09	SCREW +B 3X6
144	7-682-548-04	SCREW +B 3X8
145	♣;7-682-551-09	SCREW +B 3X14
146	7-682-553-09	SCREW +B 3X20
147	7-684-023-04	N 3, TYPE 2
148	7-684-220-02	NUT 3, HEXAGON CAP
149	7-685-533-21	SCREW +BTP 2.6X6 TYPE2 SLIT
150	7-685-645-71	SCREW +BVTP 3X6 TYPE2 SLIT
151	7-685-646-29	SCREW +BVTP 3X8 TYPE2 SLIT
152	7-685-647-71	SCREW +BVTP 3X10 TYPE2 SLIT
153	7-685-648-21	SCREW +BVTP 3X12 TYPE2 SLIT
154	7-685-772-04	SCREW +PTT 1.7X2 TYPE1
155	7-685-783-01	SCREW +PTT 2X6 (S)
156	7-685-784-01	SCREW +PTT 2X8 (S)
157	7-685-799-74	SCREW +PTT 1.7X3
158	7-685-871-01	SCREW +BVTT 3X6 (S)
159	7-685-872-01	SCREW +BVTT 3X8 (S)
160	7-688-003-11	W 3, MIDDLE
161	9-911-841-XX	CUSHION, RUBBER
162	9-911-850-XX	FELT, BRAKE
163	A-4608-204-A	MAGNET ASSY
164	A-4637-053-A	PLATE ASSY, LIFTER
165	X-4869-906-0	DRUM ASSY, BRAKE
166	X-4869-908-0	LEVER ASSY, LEAD-IN
167	♣;X-4879-501-0	BRACKET ASSY, ROLLER (A)
168	X-4879-503-2	BEARING ASSY, MOTOR
169	X-4879-505-0	REST ASSY, ARM
170	♣;X-4879-506-0	PIN ASSY, GUIDE
171	♣;X-4879-508-0	CHASSIS ASSY, MOTOR FITTING
172	♣;X-4879-509-0	CHASSIS ASSY, MECHANISM
173	X-4879-510-0	LIFTER (RIGHT) ASSY, PANEL
174	X-4879-511-0	LIFTER (LEFT) ASSY, PANEL
175	X-4879-512-0	FOOT ASSY, M
176	X-4879-513-1	BOSS ASSY, ARM
177	X-4879-514-2	PANEL ASSY
178	0-056-028-00	WASHER
179	7-671-152-01	STENLESS BALL

### NOTE:

- Items with no part number and no description are not stocked because they are seldom required for routine service.
- Items marked "♣" are not stocked since they are seldom required for routine service. Some delay should be anticipated when ordering these items.
- Due to standardization, parts with part numbers (Δ-ΔΔΔ-ΔΔΔ-XX or Δ-ΔΔΔΔ-ΔΔΔ-X) may be different from those used in the set.

### CAPACITORS:

- All capacitors are in μF. Common capacitors are omitted. Refer to the following lists for their part numbers. MF:μF, PF:μμF.

### RESISTORS

- All resistors are in ohms. Common 1/4W, 1/8W and 1/16W carbon resistors are omitted. Refer to the following lists for their part numbers.

- F : nonflammable

### COILS

- MMH : mH, UH : μH

The components identified by shading and mark  are critical for safety. Replace only with part number specified.

Les composants identifiés par une trame et une marque  sont critiques pour la sécurité. Ne les remplacer que par une pièce portant le numéro spécifié.

### SEMICONDUCTORS

- In each case, U : μ, for example: UA...: μA..., UPA...: μPA..., UPC...: μPC, UPD...: μPD...



## GENERAL SECTION

No.	Part No.	Description
180	4-879-605-00	(AEP).....LABEL, MODEL NUMBER
180	4-879-619-00	(UK).....LABEL, MODEL NUMBER
180	4-879-621-00	(US,Canadian,FL5C)...LABEL, MODEL NUMBER
180	4-879-622-00	(E).....LABEL, MODEL NUMBER
181	3-703-249-01	(E)....SCREW +PTTWH 3X6
182	3-703-043-21	(US,Canadian,UK)...LABEL, MAIN CAUTION
183	3-703-082-21	(US,FL5C).....LABEL, CAUTION

## ACCESSORY & PACKING MATERIAL

No.	Part No.	Description
201	1-555-463-00	CONNECTOR, WITH LEAD
202	2-229-507-00	WASHER
203	3-701-540-02	(AEP)....LABEL, TACK
204	3-701-613-00	BAG, POLYETHYLENE
205	3-701-630-00	BAG, POLYETHYLENE
206	3-701-634-00	BAG, POLYETHYLENE
207	3-701-806-00	ADAPTOR, 45, (E)
208	3-783-713-11	(UK,E).....MANUAL, INSTRUCTION
208	3-783-713-21	(US,FL5C)....MANUAL, INSTRUCTION
208	3-783-713-31	(Canadian)...MANUAL, INSTRUCTION
208	3-783-713-41	(AEP).....MANUAL, INSTRUCTION
209	4-815-654-00	(AEP,UK,E)...SCREW, CARTRIDGE
210	4-815-655-01	NUT
211	4-862-043-11	CUSHION, ARM
212	4-869-959-00	PLATE, LIGHT INTERCEPTION
213	4-869-962-00	ADJUSTOR, DP
214	4-869-977-00	CASE, ACCESSORY
215	4-879-596-00	TURNTABLE
216	4-879-597-01	SHEET, TURNTABLE
217	4-879-606-00	STOPPER, L
218	4-879-608-00	CUSHION, LOWER
219	4-879-609-00	CUSHION, UPPER
220	4-879-610-00	HOLDER, TT
221	4-879-612-00	(AEP,UK,E)...INDIVIDUAL CARTON
222	4-879-620-00	BAG, PROTECTION
223	A-4505-016-A	CARTRIDGE
223	1-549-105-00	(FL5C)...CARTRIDGE COMPLETE ASSY
224	X-4869-912-0	SHELL ASSY, HEAD
225	X-4869-914-2	WEIGHT ASSY, MAIN
226	X-4879-502-0	PLATE ASSY, LOCK, TRANSPORT
227	4-808-459-21	SCREW (B), MOTOR LOCK
228	4-808-459-61	SCREW (B), MOTOR LOCK
229	4-879-618-00	PLATE, PROTECTION
230	4-879-607-00	(US,Canadian)...INDIVIDUAL CARTON
231	3-795-124-31	(Canadian).....INSTRUCTION (FRENCH)
232	X-4869-915-1	(US, Canadian)..SCREW ASSY, FITTING

### NOTE:

- Items with no part number and no description are not stocked because they are seldom required for routine service.
- Items marked " ♣ " are not stocked since they are seldom required for routine service. Some delay should be anticipated when ordering these items.
- Due to standardization, parts with part numbers (Δ-ΔΔΔ-ΔΔΔ-XX or Δ-ΔΔΔΔ-ΔΔΔ-X) may be different from those used in the set.

### CAPACITORS:

- All capacitors are in μF. Common capacitors are omitted. Refer to the following lists for their part numbers. MF:μF, PF:μμF.

### RESISTORS

- All resistors are in ohms. Common 1/4W, 1/8W and 1/16W carbon resistors are omitted. Refer to the following lists for their part numbers.
- F : nonflammable

### COILS

- MMH : mH, UH : μH

## ELECTRICAL PARTS

Ref.No.	Part No.	Description
501	1-462-161-00	COIL, MOTOR
502	♣;1-508-878-00	BASE POST
503	♣.1-534-817-XX	(AEP)...CORD, POWER
503	♣.1-551-884-00	(UK)....CORD, POWER
503	♣.1-534-986-XX	(US,Canadian,FL5C)...CORD, POWER
503	♣.1-551-472-00	(E).....CORD, POWER; WITH PARALLEL BLADE PLUG
503	♣.1-555-734-00	(E).....CORD, POWER; WITH EURO-PLUG
504	♣;1-535-115-00	TERMINAL
505	♣;1-535-116-00	TERMINAL
506	♣;1-535-117-00	TERMINAL
507	♣;1-535-118-00	TERMINAL
508	♣;1-535-142-00	(AEP,UK,E,FL5C).....BASE POST 19MM (10MM PITCH)
508	♣;1-535-141-00	(US,Canadian)BASE POST 19MM(10MM PITCH)
509	1-551-063-21	CORD,PHONO (WITH CONNECTOR)
510	♣;1-560-555-00	PIN, CONNECTOR 2P
511	♣;1-560-602-00	PIN, CONNECTOR 3P
512	♣;1-560-603-00	PIN, CONNECTOR 4P
513	♣;1-560-604-00	PIN, CONNECTOR 5P
514	.....	
515	1-561-551-00	CONNECTOR, NECK CYLINDER (M)
516	♣;1-605-811-00	PC BOARD, SERVO
517	♣;1-605-812-00	PC BOARD, CONTROL (A)
518	♣;1-605-813-00	PC BOARD, CONTROL (B)
519	♣;1-605-814-00	PC BOARD, JACK
520	♣;1-605-815-00	PC BOARD, TRANSLATION
521	♣;1-605-816-00	PC BOARD, STABILITY
522	♣;1-605-817-00	PC BOARD, POWER
523	♣;1-605-818-00	PC BOARD, RECORD SENSOR (A)
524	♣;1-605-819-00	PC BOARD, RECORD SENSOR (B)
525	.....	
526	♣;1-605-821-00	PC BOARD, SWITCH (A)
527	♣;1-605-822-00	PC BOARD, PHONO (1)
528	♣;1-605-823-00	PC BOARD, INTERRUPTER
529	♣;1-605-938-00	PC BOARD, PHONO (B)
530	♣;A-4619-176-A	MOUNTED PCB, AMPLIFIER, SERVO
531	♣;A-4646-083-A	MOUNTED PCB, MOTOR
532	♣.1-552-535-00	(E)....VOLTAGE SELECTOR
C1	♣.1-123-508-00	ELECT 1000MF 20% 35V
C2	♣.1-123-508-00	ELECT 1000MF 20% 35V
D101	8-719-200-02	DIODE 10E-2
D102	8-719-200-02	DIODE 10E-2
D103	8-719-200-02	DIODE 10E-2
D104	8-719-200-02	DIODE 10E-2
D105	8-719-996-06	DIODE EQA01-06
D106	8-719-996-06	DIODE EQA01-06

The components identified by shading and mark ♣ are critical for safety. Replace only with part number specified.

Les composants identifiés par une trame et une marque ♣ sont critiques pour la sécurité. Ne les remplacer que par une pièce portant le numéro spécifié.

### SEMICONDUCTORS

In each case, U : μ, for example:  
 UA....: μA...., UPA....: μPA...., UPC....: μPC,  
 UPD....: μPD....



## ELECTRICAL PARTS

Ref.No.	Part No.	Description
D107	8-719-815-55	DIODE 1S1555
D201	8-719-996-06	DIODE EQA01-06
D401	8-719-815-55	DIODE 1S1555
D402	8-719-200-02	DIODE 10E-2
D501	8-719-101-11	DIODE SR110
D701	8-719-901-31	DIODE SLP131B
D702	8-719-901-31	DIODE SLP131B
D801	8-719-812-33	DIODE TLG123
D802	8-719-812-31	DIODE TLR123
D803	8-719-812-31	DIODE TLR123
D804	8-719-812-31	DIODE TLR123
D805	8-719-812-31	DIODE TLR123
D806	8-719-812-31	DIODE TLR123
D807	8-719-812-33	DIODE TLG123
D808	8-719-812-31	DIODE TLR123
H1	8-719-903-00	DIODE HL-300C
H2	8-719-903-00	DIODE HL-300C
IC201	8-751-930-00	IC CX-193
IC202	8-759-155-58	IC UPC4558C
IC301	8-759-155-58	IC UPC4558C
IC401	8-759-820-24	IC LM6402A024
IC401	8-759-800-08	IC LM6402A044
IC402	8-759-155-58	IC UPC4558C
J301	1-507-688-21	JACK (STEREO PLUG)
L401	1-408-096-00	MICRO INDUCTOR 470UH
M801	1-541-163-00	MOTOR
M802	1-541-163-00	MOTOR
MGH	1-543-167-00	HEAD (TURN DETECTION)
PM801	1-454-297-00	SOLENOID, PLUNGER
Q101	8-729-612-77	TRANSISTOR 2SA1027R
Q102	8-729-141-43	TRANSISTOR 2SD414
Q103	8-729-663-47	TRANSISTOR 2SC1364
Q104	8-729-141-43	TRANSISTOR 2SD414
Q105	8-729-663-47	TRANSISTOR 2SC1364
Q106	8-729-612-77	TRANSISTOR 2SA1027R
Q201	8-729-663-47	TRANSISTOR 2SC1364
Q202	8-729-663-47	TRANSISTOR 2SC1364
Q203	8-729-612-77	TRANSISTOR 2SA1027R
Q204	8-729-663-47	TRANSISTOR 2SC1364
Q301	8-729-180-93	TRANSISTOR 2SD809
Q302	8-729-173-13	TRANSISTOR 2SB731
Q303	8-729-180-93	TRANSISTOR 2SD809
Q304	8-729-173-13	TRANSISTOR 2SB731
Q401	8-729-663-47	TRANSISTOR 2SC1364
Q402	8-729-663-47	TRANSISTOR 2SC1364
Q403	8-729-663-47	TRANSISTOR 2SC1364

## ELECTRICAL PARTS

Ref.No.	Part No.	Description
Q404	8-729-663-47	TRANSISTOR 2SC1364
Q405	8-729-663-47	TRANSISTOR 2SC1364
Q406	8-729-663-47	TRANSISTOR 2SC1364
Q407	8-729-663-47	TRANSISTOR 2SC1364
Q408	8-729-612-77	TRANSISTOR 2SA1027R
Q409	8-729-612-77	TRANSISTOR 2SA1027R
Q410	8-729-180-93	TRANSISTOR 2SD809
Q411	8-729-173-13	TRANSISTOR 2SB731
Q412	8-729-180-93	TRANSISTOR 2SD809
Q413	8-729-173-13	TRANSISTOR 2SB731
Q414	8-729-177-43	TRANSISTOR 2SD774
Q415	8-729-177-43	TRANSISTOR 2SD774
Q416	8-729-612-77	TRANSISTOR 2SA1027R
Q417	8-729-663-47	TRANSISTOR 2SC1364
Q418	8-729-663-47	TRANSISTOR 2SC1364
Q419	8-729-612-77	TRANSISTOR 2SA1027R
Q420	8-729-612-77	TRANSISTOR 2SA1027R
Q501	8-729-101-13	TRANSISTOR PH103
Q601	8-729-101-01	TRANSISTOR PH101
Q602	8-729-101-01	TRANSISTOR PH101
R103	▲.1-212-869-00	FUSIBLE 33 5% 1/4W F
R109	▲.1-212-877-51	FUSIBLE 68 5% 1/4W F
R115	▲.1-244-851-00	CARBON 120 5% 1/2W
R441	▲.1-212-877-51	FUSIBLE 68 5% 1/4W F
R442	▲.1-212-877-51	FUSIBLE 68 5% 1/4W F
RV201	1-224-254-XX	RES, ADJ, METAL GLAZE 47K
RV202	1-224-255-XX	RES, ADJ, METAL GLAZE 100K
RV301	1-226-236-00	RES, ADJ, CARBON 10K
RV302	1-226-236-00	RES, ADJ, CARBON 10K
RV303	1-226-239-00	RES, ADJ, CARBON 100K
RV304	1-226-239-00	RES, ADJ, CARBON 100K
S1	▲.1-553-909-00	SWITCH, PUSH
S2	1-553-320-00	SWITCH
S3	1-553-856-00	SWITCH, KEY BOARD
S4	1-553-856-00	SWITCH, KEY BOARD
S5	1-553-856-00	SWITCH, KEY BOARD
S6	1-553-856-00	SWITCH, KEY BOARD
S7	1-553-856-00	SWITCH, KEY BOARD
S8	1-553-855-00	SWITCH, PUSH
S9	1-553-855-00	SWITCH, PUSH
S10	1-553-321-00	SWITCH, PUSH
T801	▲.1-446-851-21	(E).....TRANSFORMER, POWER
T801	▲.1-447-124-00	(AEP,UK).....TRANSFORMER, POWER
T801	▲.1-447-125-00	(US,Canadian,FL5C)..TRANSFORMER, POWER
X1	1-527-380-21	OSCILLATOR, CRYSTAL
X2	1-527-532-00	OSCILLATOR, CERAMIC

### NOTE:

- Items with no part number and no description are not stocked because they are seldom required for routine service.
- Items marked "▲" are not stocked since they are seldom required for routine service. Some delay should be anticipated when ordering these items.
- Due to standardization, parts with part numbers (▲-▲▲▲-▲▲-XX or ▲-▲▲▲-▲▲-X) may be different from those used in the set.

### CAPACITORS:

- All capacitors are in  $\mu\text{F}$ . Common capacitors are omitted. Refer to the following lists for their part numbers. MF: $\mu\text{F}$ , PF: $\mu\text{F}$ .

### RESISTORS

- All resistors are in ohms. Common 1/4W, 1/8W and 1/16W carbon resistors are omitted. Refer to the following lists for their part numbers.
- F : nonflammable

### COILS

- MMH : mH, UH :  $\mu\text{H}$

The components identified by shading and mark ▲ are critical for safety. Replace only with part number specified.

Les composants identifiés par une trame et une marque ▲ sont critiques pour la sécurité. Ne les remplacer que par une pièce portant le numéro spécifié.

### SEMICONDUCTORS

- In each case, U :  $\mu$ , for example:  
 UA.... :  $\mu\text{A}$ ...., UPA.... :  $\mu\text{PA}$ ...., UPC.... :  $\mu\text{PC}$ ,  
 UPD.... :  $\mu\text{PD}$ ....

**ELECTROLYTIC CAPACITORS**

RATING → : Use the high voltage rated one.						
CAP. (μF)	6.3 VOLT.	10 VOLT.	16 VOLT.	25 VOLT.	35 VOLT.	50 VOLT.
	PART No.	PART No.	PART No.	PART No.	PART No.	PART No.
0.47					→	1-121-726-00
1.0					→	1-121-391-00
2.2					→	1-121-450-00
3.3	→	→	→	1-121-392-00	→	1-121-393-00
4.7	→	→	→	1-121-395-00	→	1-121-396-00
10	→	→	1-121-651-00	1-121-398-00	→	1-121-738-00
22	→	→	1-121-479-00	1-121-480-00	1-121-662-00	1-121-152-00
33	→	→	1-121-403-00	1-121-404-00	1-121-652-00	1-121-405-00
47	→	1-121-352-00	1-121-409-00	1-121-410-00	1-121-653-00	1-121-411-00
100	→	1-121-414-00	1-121-415-00	1-121-416-00	1-121-357-00	1-121-417-00
220	1-121-419-00	1-121-420-00	1-121-421-00	1-121-422-00	1-121-261-00	1-121-423-00
330	1-121-751-00	1-121-805-00	1-121-521-00	1-121-654-00	1-121-655-00	1-121-656-00
470	1-121-424-00	1-121-425-00	1-121-426-00	1-121-733-00	1-121-361-00	1-121-810-00
1000	-	1-121-736-00	1-121-245-00	1-121-657-00	1-121-388-00	1-123-061-00
2200	1-121-658-00	1-121-659-00	1-121-660-00	1-123-067-00	1-121-984-00	-
3300	1-121-661-00	1-123-075-00	1-123-071-00	-	-	-

CAP. (μF)	100 VOLT.	160 VOLT.	250 VOLT.	350 VOLT.
	PART No.	PART No.	PART No.	PART No.
0.47	-	-	-	-
1.0	1-123-249-00	1-123-252-00	1-123-003-00	1-121-168-00
2.2	1-123-250-00	1-123-026-00	-	1-123-028-00
3.3	1-121-995-00	-	1-123-004-00	1-123-006-00
4.7	1-123-255-00	1-121-246-00	1-121-759-00	1-123-007-00
10	1-121-126-00	1-121-999-00	1-123-254-00	1-123-008-00
22	1-121-996-00	1-123-253-00	1-123-005-00	1-123-022-00
33	1-121-997-00	1-121-757-00	-	-
47	1-123-251-00	1-121-919-00	-	-
100	1-123-084-00	-	-	-

**CERAMIC CAPACITORS**

RATING							
CAP. (pF)	50 VOLT.	CAP. (pF)	50 VOLT.	CAP. (pF)	50 VOLT.	CAP. (μF)	50 VOLT.
	PART No.		PART No.		PART No.		PART No.
0.5	1-101-837-00	22	1-102-959-00	150	1-101-361-00	0.001	1-102-074-00
0.75	1-101-586-00	24	1-102-960-00	160	1-101-367-00	0.0012	1-102-118-00
1.0	1-102-934-00	27	1-102-961-00	180	1-102-976-00	0.0015	1-102-119-00
1.5	1-101-576-00	30	1-102-962-00	200	1-102-977-00	0.0018	1-102-120-00
2.0	1-102-935-00	33	1-102-963-00	220	1-102-978-00	0.0022	1-102-121-00
3	1-102-936-00	36	1-102-964-00	240	1-102-979-00	0.0027	1-102-122-00
4	1-102-937-00	39	1-102-965-00	270	1-102-980-00	0.0033	1-102-123-00
5	1-102-942-00	43	1-102-966-00	300	1-102-981-00	0.0039	1-102-124-00
6	1-102-943-00	47	1-101-880-00	330	1-102-820-00	0.0047	1-102-125-00
7	1-102-944-00	51	1-101-882-00	360	1-102-821-00	0.0056	1-102-126-00
8	1-102-945-00	56	1-101-884-00	390	1-102-822-00	0.0068	1-102-127-00
9	1-102-946-00	62	1-101-886-00	430	1-102-823-00	0.0082	1-102-128-00
10	1-102-947-00	68	1-101-888-00	470	1-102-824-00	0.01	1-102-129-00
11	1-102-948-00	75	1-101-890-00	510	1-101-059-00	0.022	1-101-005-00
12	1-102-949-00	82	1-102-971-00	560	1-102-115-00	0.047	1-101-006-00
13	1-102-950-00	91	1-102-972-00	680	1-102-116-00		
15	1-102-951-00	100	1-102-973-00	820	1-102-117-00		
16	1-102-952-00	110	1-102-815-00				
18	1-102-953-00	120	1-102-816-00				
20	1-102-958-00	130	1-101-081-00				

0.001μF = 1,000pF

**CERAMIC (SEMICONDUCTOR) CAPACITORS**

RATING → : Use the high voltage rated one.					
CAP. (μF)	25 VOLT.	50 VOLT.	CAP. (μF)	25 VOLT.	50 VOLT.
	PART No.	PART No.		PART No.	PART No.
0.001	→	1-161-039-00	0.018	1-161-016-00	1-161-054-00
0.0012	→	1-161-040-00	0.022	1-161-017-00	1-161-055-00
0.0015		1-161-041-00	0.027	1-161-018-00	1-161-056-00
0.0018		1-161-042-00	0.033	1-161-019-00	1-161-057-00
0.0022		1-161-043-00	0.039	1-161-010-00	1-161-058-00
0.0027	→	1-161-044-00	0.047	1-161-021-00	1-161-059-00
0.0033	→	1-161-045-00	0.056	→	1-161-060-00
0.0039	→	1-161-046-00	0.068	→	1-161-061-00
0.0047	→	1-161-047-00	0.082	1-161-024-00	1-161-062-00
0.0056	→	1-161-048-00	0.1	1-161-025-00	1-161-063-00
0.0068	→	1-161-049-00			
0.0082	1-161-012-00	1-161-050-00			
0.01	1-161-013-00	1-161-051-00			
0.012	→	1-161-052-00			
0.015	1-161-015-00	1-161-053-00			



## MYLAR CAPACITORS

RATING											
CAP. (μF)	50 VOLT.	100 VOLT.	200 VOLT.	CAP. (μF)	50 VOLT.	100 VOLT.	200 VOLT.	CAP. (μF)	50 VOLT.	100 VOLT.	200 VOLT.
	PART No.	PART No.	PART No.		PART No.	PART No.	PART No.		PART No.	PART No.	PART No.
0.001	1-108-227-00	1-108-365-00	1-108-409-00	0.01	1-108-239-00	1-108-377-00	1-108-421-00	0.1	1-108-251-00	1-108-389-00	1-108-433-00
0.0012	1-108-351-00	1-108-366-00	1-108-410-00	0.012	1-108-357-00	1-108-378-00	1-108-422-00	0.12	1-108-363-00	1-108-390-00	1-108-434-00
0.0015	1-108-228-00	1-108-367-00	1-108-411-00	0.015	1-108-240-00	1-108-379-00	1-108-423-00	0.15	1-108-252-00	1-108-391-00	1-108-435-00
0.0018	1-108-352-00	1-108-368-00	1-108-412-00	0.018	1-108-358-00	1-108-380-00	1-108-424-00	0.18	1-108-364-00	1-108-392-00	1-108-436-00
0.0022	1-108-230-00	1-108-369-00	1-108-413-00	0.022	1-108-242-00	1-108-381-00	1-108-425-00	0.22	1-108-254-00	1-108-393-00	1-108-437-00
0.0027	1-108-353-00	1-108-370-00	1-108-414-00	0.027	1-108-359-00	1-108-382-00	1-108-426-00	0.27	1-108-854-00	-	-
0.0033	1-108-232-00	1-108-371-00	1-108-415-00	0.033	1-108-244-00	1-108-383-00	1-108-427-00	0.33	1-108-855-00	-	-
0.0039	1-108-354-00	1-108-372-00	1-108-416-00	0.039	1-108-360-00	1-108-384-00	1-108-428-00	0.39	1-108-856-00	-	-
0.0047	1-108-234-00	1-108-373-00	1-108-417-00	0.047	1-108-246-00	1-108-385-00	1-108-429-00	0.47	1-108-857-00	-	-
0.0056	1-108-355-00	1-108-374-00	1-108-418-00	0.056	1-108-361-00	1-108-386-00	1-108-430-00				
0.0068	1-108-237-00	1-108-375-00	1-108-419-00	0.068	1-108-249-00	1-108-387-00	1-108-431-00				
0.0082	1-108-356-00	1-108-376-00	1-108-420-00	0.082	1-108-362-00	1-108-388-00	1-108-432-00				

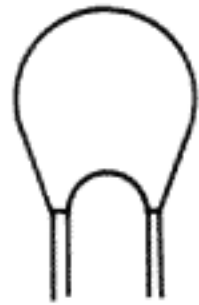

## TANTALUM CAPACITORS

RATING → : Use the high voltage rated one.							
CAP. (μF)	3.15 VOLT.	6.3 VOLT.	10 VOLT.	16 VOLT.	20 VOLT.	25 VOLT.	35 VOLT.
	PART No.	PART No.	PART No.	PART No.	PART No.	PART No.	PART No.
0.01					→	→	1-131-396-00
0.015						→	1-131-397-00
0.022						→	1-131-398-00
0.033						→	1-131-399-00
0.047						→	1-131-400-00
0.068					→	→	1-131-401-00
0.1					→	→	1-131-402-00
0.15					→	→	1-131-403-00
0.22					→	→	1-131-404-00
0.33					→	1-131-409-00	1-131-405-00
0.47	-	-	-	-	1-131-412-00	→	1-131-406-00
0.68	-	-	-	1-131-415-00	→	1-131-410-00	1-131-407-00
1.0	-	-	1-131-418-00	-	1-131-413-00	→	1-131-408-00
1.5	-	1-131-421-00	-	1-131-416-00	→	1-131-411-00	1-131-348-00
2.2	1-131-424-00	-	1-131-419-00	-	1-131-414-00	1-131-355-00	1-131-349-00
3.3	-	1-131-422-00	-	1-131-417-00	1-131-362-00	1-131-356-00	1-131-350-00
4.7	1-131-425-00	-	1-131-420-00	1-131-369-00	1-131-363-00	1-131-357-00	1-131-351-00
6.8	-	1-131-423-00	1-131-376-00	1-131-370-00	1-131-364-00	1-131-358-00	1-131-352-00
10	1-131-426-00	1-131-383-00	1-131-377-00	1-131-371-00	1-131-365-00	1-131-359-00	1-131-353-00
15	1-131-390-00	1-131-384-00	1-131-378-00	1-131-372-00	1-131-366-00	1-131-360-00	-
22	1-131-391-00	1-131-385-00	1-131-379-00	1-131-373-00	1-131-367-00		
33	1-131-392-00	1-131-386-00	1-131-380-00	1-131-374-00			
47	1-131-393-00	1-131-387-00	1-131-381-00	-			
68	1-131-394-00	1-131-388-00	-	-			
100	1-131-395-00	-	-	-			

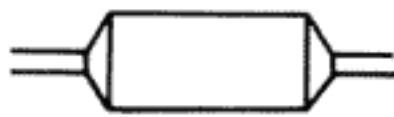

## TANTALUM CAPACITORS

RATING						
CAP. (μF)	3 VOLT.	6.3 VOLT.	10 VOLT.	16 VOLT.	20 VOLT.	35 VOLT.
	PART No.	PART No.	PART No.	PART No.	PART No.	PART No.
0.033						1-131-273-00
0.047						1-131-274-00
0.068						1-131-275-00
0.1						1-131-276-00
0.15						1-131-277-00
0.22			-	-	1-131-262-00	1-131-278-00
0.33			-	-	1-131-263-00	1-131-279-00
0.47			1-131-169-00	-	1-131-264-00	1-131-280-00
0.68			-	1-131-258-00	1-131-265-00	1-131-281-00
1.0			1-131-254-00	-	1-131-266-00	1-131-282-00
1.5		1-131-250-00	-	-	1-131-267-00	1-131-283-00
2.2		-	-	1-131-259-00	1-131-268-00	1-131-284-00
3.3		-	1-131-255-00	-	1-131-269-00	-
4.7		1-131-251-00	1-131-171-00	-	1-131-270-00	-
6.8		-	-	1-131-260-00	1-131-271-00	-
10	-	-	1-131-256-00	-	1-131-272-00	-
15	-	1-131-252-00	-	1-131-261-00		
22	-	-	1-131-257-00	-		
33	1-131-176-00	1-131-253-00	1-131-173-00	-		
47	1-131-288-00	1-131-174-00	-	-		
100	1-131-177-00					



**1/4 WATT CARBON RESISTORS**

Ω	Part No.	Ω	Part No.	Ω	Part No.	Ω	Part No.	Ω	Part No.	Ω	Part No.	Ω	Part No.
1.0	1-246-401-00	10	1-246-425-00	100	1-246-449-00	1.0k	1-246-473-00	10k	1-246-497-00	100k	1-246-521-00	1.0M	1-246-545-00
1.1	1-246-402-00	11	1-246-426-00	110	1-246-450-00	1.1k	1-246-474-00	11k	1-246-498-00	110k	1-246-522-00	1.1M	1-210-814-00
1.2	1-246-403-00	12	1-246-427-00	120	1-246-451-00	1.2k	1-246-475-00	12k	1-246-499-00	120k	1-246-523-00	1.2M	1-210-815-00
1.3	1-246-404-00	13	1-246-428-00	130	1-246-452-00	1.3k	1-246-476-00	13k	1-246-500-00	130k	1-246-524-00	1.3M	1-210-816-00
1.5	1-246-405-00	15	1-246-429-00	150	1-246-453-00	1.5k	1-246-477-00	15k	1-246-501-00	150k	1-246-525-00	1.5M	1-210-817-00
1.6	1-246-406-00	16	1-246-430-00	160	1-246-454-00	1.6k	1-246-478-00	16k	1-246-502-00	160k	1-246-526-00	1.6M	1-210-818-00
1.8	1-246-407-00	18	1-246-431-00	180	1-246-455-00	1.8k	1-246-479-00	18k	1-246-503-00	180k	1-246-527-00	1.8M	1-210-819-00
2.0	1-246-408-00	20	1-246-432-00	200	1-246-456-00	2.0k	1-246-480-00	20k	1-246-504-00	200k	1-246-528-00	2.0M	1-210-820-00
2.2	1-246-409-00	22	1-246-433-00	220	1-246-457-00	2.2k	1-246-481-00	22k	1-246-505-00	220k	1-246-529-00	2.2M	1-210-821-00
2.4	1-246-410-00	24	1-246-434-00	240	1-246-458-00	2.4k	1-246-482-00	24k	1-246-506-00	240k	1-246-530-00	2.4M	1-244-754-00
2.7	1-246-411-00	27	1-246-435-00	270	1-246-459-00	2.7k	1-246-483-00	27k	1-246-507-00	270k	1-246-531-00	2.7M	1-244-755-00
3.0	1-246-412-00	30	1-246-436-00	300	1-246-460-00	3.0k	1-246-484-00	30k	1-246-508-00	300k	1-246-532-00	3.0M	1-244-756-00
3.3	1-246-413-00	33	1-246-437-00	330	1-246-461-00	3.3k	1-246-485-00	33k	1-246-509-00	330k	1-246-533-00	3.3M	1-244-757-00
3.6	1-246-414-00	36	1-246-438-00	360	1-246-462-00	3.6k	1-246-486-00	36k	1-246-510-00	360k	1-246-534-00	3.6M	1-244-758-00
3.9	1-246-415-00	39	1-246-439-00	390	1-246-463-00	3.9k	1-246-487-00	39k	1-246-511-00	390k	1-246-535-00	3.9M	1-244-759-00
4.3	1-246-416-00	43	1-246-440-00	430	1-246-464-00	4.3k	1-246-488-00	43k	1-246-512-00	430k	1-246-536-00	4.3M	1-244-760-00
4.7	1-246-417-00	47	1-246-441-00	470	1-246-465-00	4.7k	1-246-489-00	47k	1-246-513-00	470k	1-246-537-00	4.7M	1-244-761-00
5.1	1-246-418-00	51	1-246-442-00	510	1-246-466-00	5.1k	1-246-490-00	51k	1-246-514-00	510k	1-246-538-00	5.1M	1-244-762-00
5.6	1-246-419-00	56	1-246-443-00	560	1-246-467-00	5.6k	1-246-491-00	56k	1-246-515-00	560k	1-246-539-00		
6.2	1-246-420-00	62	1-246-444-00	620	1-246-468-00	6.2k	1-246-492-00	62k	1-246-516-00	620k	1-246-540-00		
6.8	1-246-421-00	68	1-246-445-00	680	1-246-469-00	6.8k	1-246-493-00	68k	1-246-517-00	680k	1-246-541-00		
7.5	1-246-422-00	75	1-246-446-00	750	1-246-470-00	7.5k	1-246-494-00	75k	1-246-518-00	750k	1-246-542-00		
8.2	1-246-423-00	82	1-246-447-00	820	1-246-471-00	8.2k	1-246-495-00	82k	1-246-519-00	820k	1-246-543-00		
9.1	1-246-424-00	91	1-246-448-00	910	1-246-472-00	9.1k	1-246-496-00	91k	1-246-520-00	910k	1-246-544-00		

**HARDWARE NOMENCLATURE**

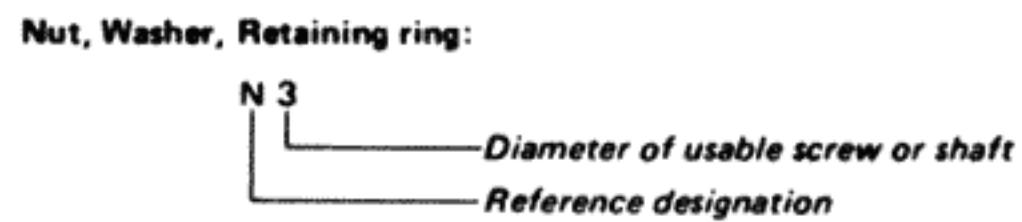
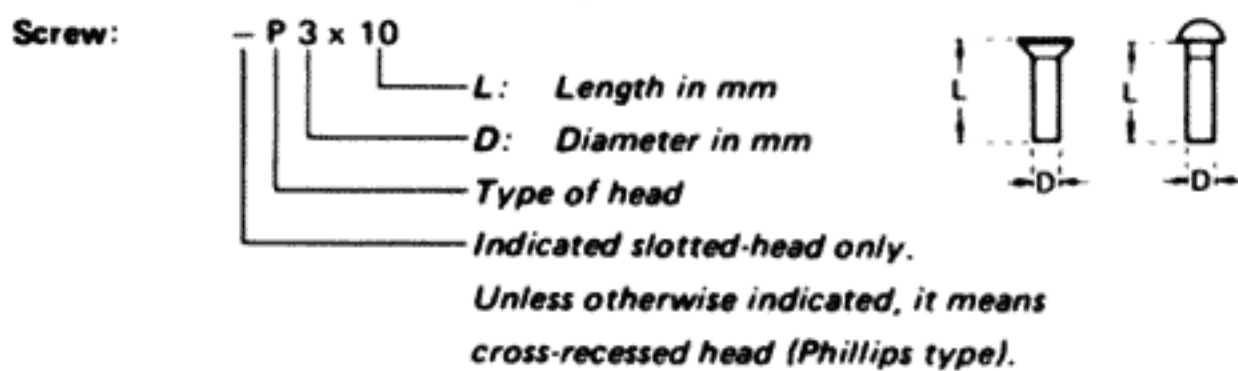

Reference Designation	Shape	Description	Remarks
<b>SCREWS</b>			
P		pan-head screw	binding-head (B) screw for replacement
PWH		pan-head screw with washer face	binding-head (B) screw and flat washer for replacement
PS PSP		pan-head screw with spring washer	binding-head (B) screw and spring washer for replacement
PSW PSPW		pan-head screw with spring and flat washers	binding-head (B) screw and spring and flat washers for replacement
R		round-head screw	binding-head (B) screw for replacement
K		flat-countersunk-head screw	
RK		oval-countersunk-head screw	
B		binding-head screw	
T		truss-head screw	binding-head (B) screw for replacement
F		flat-fillister-head screw	
RF		fillister-head screw	
BV		braizer-head screw	

Reference Designation	Shape	Description	Remarks
<b>SELF-TAPPING SCREWS</b>			
TA		self-tapping screw	ex: TA, P 3 x 10
PTP		pan-head self-tapping screw	binding-head self-tapping (TA, B) screw for replacement
PTPWH		pan-head self-tapping screw with washer face	binding-head self-tapping (TA, B) screw and flat washer for replacement
PTTWH		pan-head thread-rolling screw with washer face	binding-head (B) screw and flat washer for replacement
<b>SET SCREWS</b>			
SC		set screw	
SC		hexagon-socket set screw	ex: SC 2.6 x 4, hexagon socket
<b>NUT</b>			
N		nut	
<b>WASHERS</b>			
W		flat washer	
SW		spring washer	
LW		internal-tooth lock washer	ex: LW3, internal
LW		external-tooth lock washer	ex: LW3, external
<b>RETAINING RINGS</b>			
E		retaining ring	
G		grip-type retaining ring	

## TROUBLE CHECKS

The following trouble checks will help you correct most common problems encountered with a turntable system. Should any problem persist after you have made these checks, consult your nearest Sony service facility.

Before proceeding with these trouble checks, first refer to the connections on page 10 and the operating procedures on page 11.

TROUBLES	CAUSES	WHAT TO DO
The tonearm does not lower on the record but returns to the arm rest.	Transparent record	For 30 cm (12 in) records, place the rubber mat by turning half a circle or play records manually. For 17 cm (7 in) records, place the supplied sheet underneath a record.
The tonearm always lowers on the point for 30 cm records.	A rubber mat other than the one supplied being used.	Use the supplied rubber mat.
	Incorrect placement of the supplied rubber mat	Align the holes in the rubber mat with the holes of the platter.
Impaired tone quality	Improper tonearm balance or tracking-force	Adjust the tonearm, referring to page 7.
	Dusty stylus	Clean the stylus with a soft brush from back to front.
	Worn stylus	The stylus life is approx. 400 hours. Replace with a new stylus.
Auto return does not operate at the end of play.	A record with shallow return grooves being played by a cartridge with low tracking force	Apply more tracking-force.
No audio from one channel	Loose connection of phono cord	Connect the cord firmly.
Steady low-pitched humming sound	Loose attachment of the cartridge shell to the tonearm	Fix the shell to the tonearm firmly.
	Ground wire is not connected to the amplifier.	Connect the ground wire to the amplifier.
Groove skipping ; tonearm skating ; tonearm not advancing.	Improper tracking force	Apply proper tracking-force. (See page 9.)
	Turntable not level	Place the turntable on a level surface.
	Defective record	
Loud rumble or low-frequency howl*	The turntable is subjected to external vibration.	Place the turntable on a solid surface free from external vibration.
	The turntable is placed too near the speaker.	Locate the turntable as far away from the speaker as possible.

\* This is called "acoustic feedback" and is caused when vibrations from the speakers are transmitted through the air or via solid objects (such as the shelves, the cabinet, the floor, etc.) to the turntable, where it is picked up by the stylus, amplified and reproduced through the speakers once again.