

PS-J10

SERVICE MANUAL

US Model
Canadian Model
AEP Model
UK Model
E Model



Photo: SILVER

SPECIFICATIONS

Platter	18.3 cm, aluminum-alloy diecast
Motor	DC servo motor
Drive system	Belt drive
Speed	33 1/3 rpm, 45 rpm
Automatic system	Return, reject
Tone arm type	Statically balanced
Cartridge type	Moving magnet type
Stylus	CN-234
General	
Dimensions	Approx. 270 × 88.5 × 320 mm (w/h/d) (10 3/4 × 3 1/2 × 12 5/8 inches)
Mass	Approx. 1.9 kg (4 lbs 3 oz)
Power requirement	220 - 230 V AC, 50 / 60 Hz (AEP, UK MODEL) 110 - 120 or 220 - 240 V AC adjustable, 50 / 60 Hz (E MODEL) 120 V AC, 50 / 60 Hz (US, Canadian MODEL)
Power consumption	4 W
Supplied accessory	45 rpm adaptor (1)

Design and specifications are subject to change without notice.

Replacing the Stylus

Use the procedure below to replace the stylus after about 400 hours of use because a worn stylus will damage records. A CN-234 replacement stylus is available at your Sony dealer.

- 1 Turn off the amplifier.
- 2 While holding the cartridge, detach the stylus assembly as illustrated.
- 3 Insert the new stylus into the cartridge.

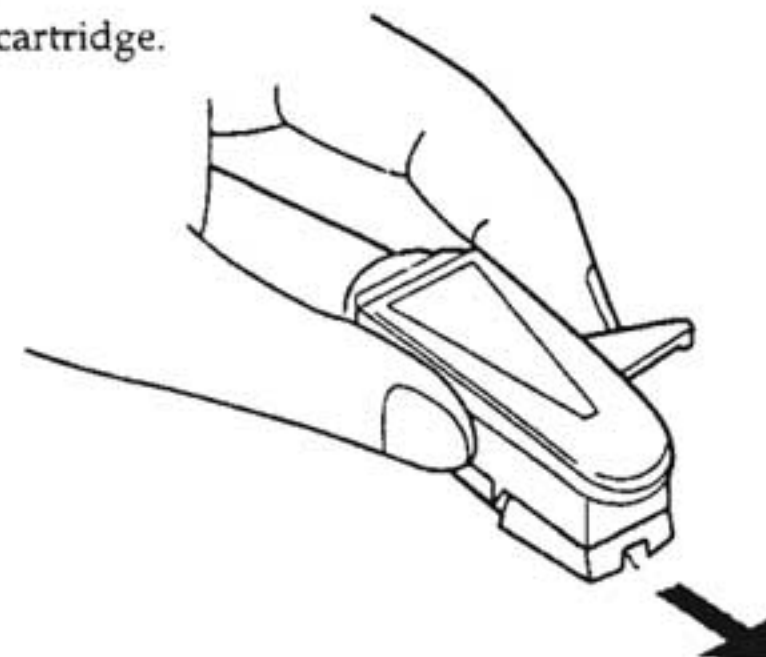

SAFETY-RELATED COMPONENT WARNING !!

COMPONENTS IDENTIFIED BY MARK \triangle OR DOTTED LINE WITH MARK \triangle ON THE SCHEMATIC DIAGRAMS AND IN THE PARTS LIST ARE CRITICAL TO SAFE OPERATION. REPLACE THESE COMPONENTS WITH SONY PARTS WHOSE PART NUMBERS APPEAR AS SHOWN IN THIS MANUAL OR IN SUPPLEMENTS PUBLISHED BY SONY.

ATTENTION AU COMPOSANT AYANT RAPPORT À LA SÉCURITÉ!!

LES COMPOSANTS IDENTIFIÉS PAR UNE MARQUE \triangle SUR LES DIAGRAMMES SCHÉMATIQUES ET LA LISTE DES PIÈCES SONT CRITIQUES POUR LA SÉCURITÉ DE FONCTIONNEMENT. NE REMPLACER CES COMPOSANTS QUE PAR DES PIÈCES SONY DONT LES NUMÉROS SONT DONNÉS DANS CE MANUEL OU DANS LES SUPPLÉMENTS PUBLIÉS PAR SONY.

STEREO TURNTABLE SYSTEM



SONY®

SECTION 1 GENERAL

This section is extracted from instruction manual.

Connections

Assembling the Turntable

- 1 Turn the large plastic gear counterclockwise until the notch aligns with the small plastic gear.
- 2 Remove the adapter for 17-cm records from the adapter stay.
- 3 Gripping the platter through the two holes, place it carefully onto the spindle.
- 4 Turn the platter clockwise until the ribbon tape aligns with the pulley, then pull both ends of the ribbon, gently stretching the rubber belt around the pulley.
- 5 Carefully remove the ribbon tape without twisting the rubber belt.
- 6 Put the adapter for 17-cm records back into the adapter stay, aligning the ▼ mark on the adapter stay with the ▲ mark below.
- 7 Place the rubber mat onto the platter.

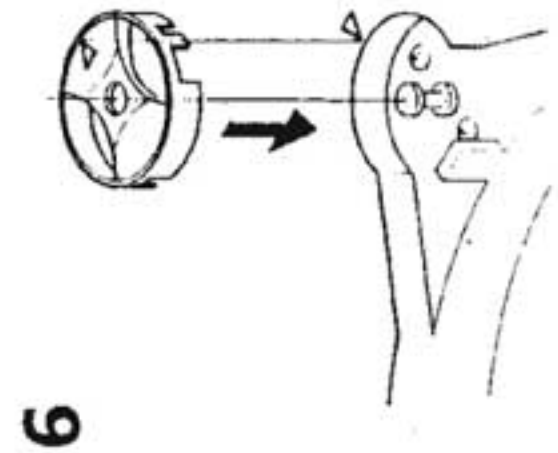
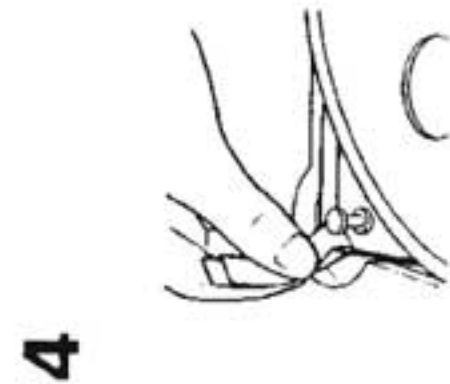
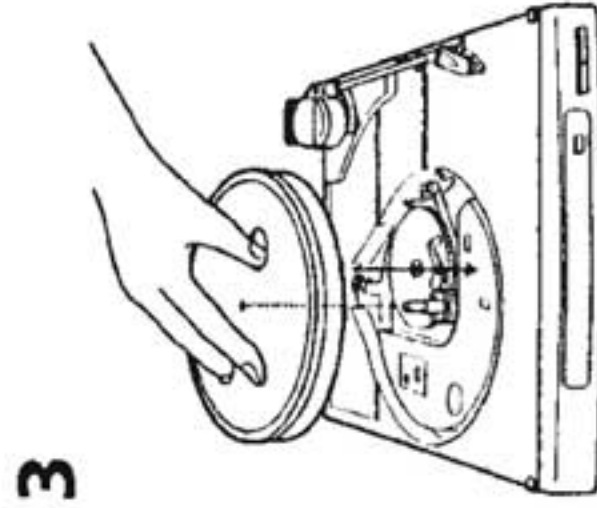
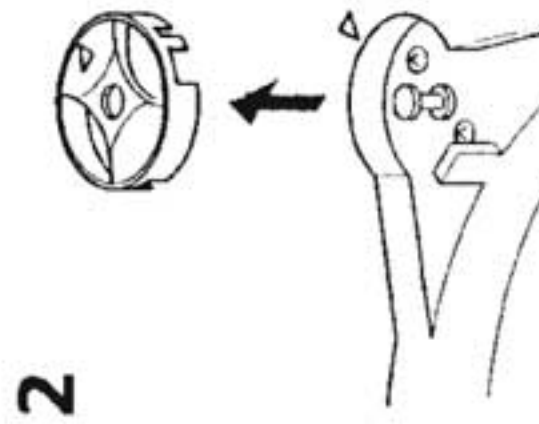
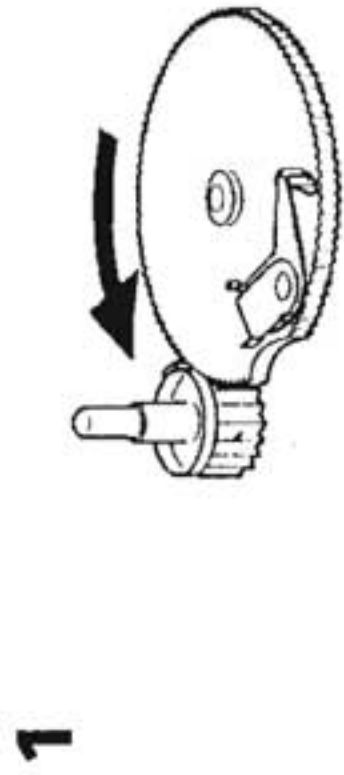
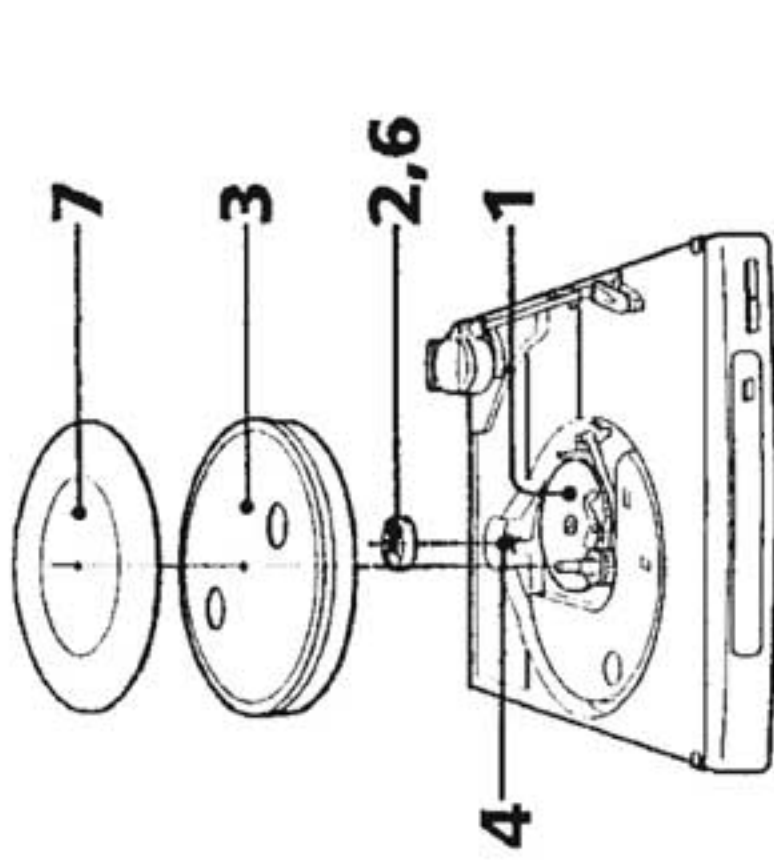

Playing Records

- 1 Place a record on the platter.
- 2 Press **SPEED** to select the speed. The indicator lights to show the selected speed.
- 3 Remove the cover from the cartridge.
- 4 Press **ARM LIFTER**. The tone arm rises.
- 5 Move the tone arm to the proper position over the record. The platter automatically starts rotating.
- 6 Press **ARM LIFTER** again. The tone arm lowers onto the record and the record starts playing.

When the record comes to an end

The tone arm returns to the arm rest and the turntable stops.

To stop during play

Press **REJECT**.

To move the tone arm to a different point on the record

Press **ARM LIFTER** to raise the tone arm, move the tone arm to the proper position on the record, then press **ARM LIFTER** again.

To play a 17-cm record

Use the supplied adaptor. When you have finished using the adaptor, put it back in the adaptor stay with the ▲ mark aligned to the ▼ mark on the adaptor stay.

If the tone arm begins to return to the arm rest as you move it towards the center

Do not resist this movement, as it may damage the automatic return mechanism.

If the tone arm does not return to the arm rest at the end of the record

Press **REJECT**.

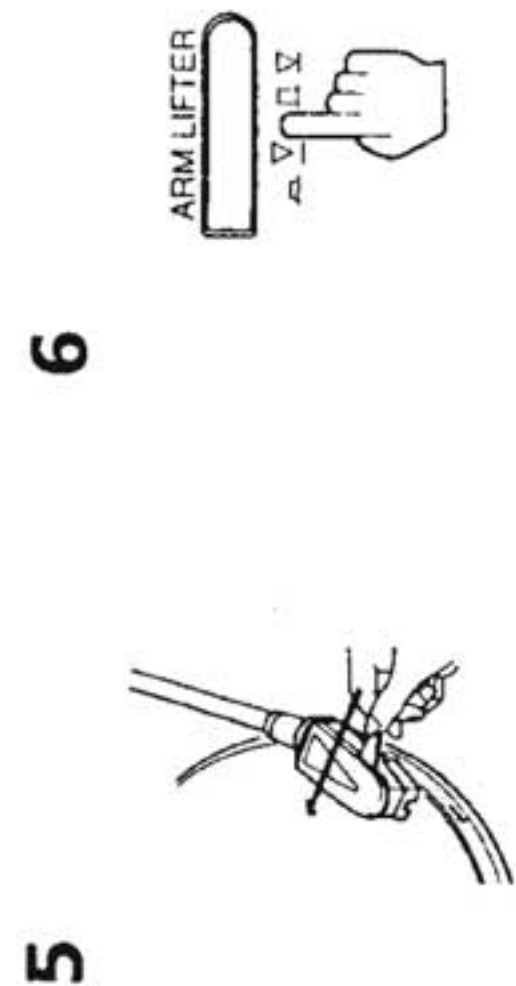
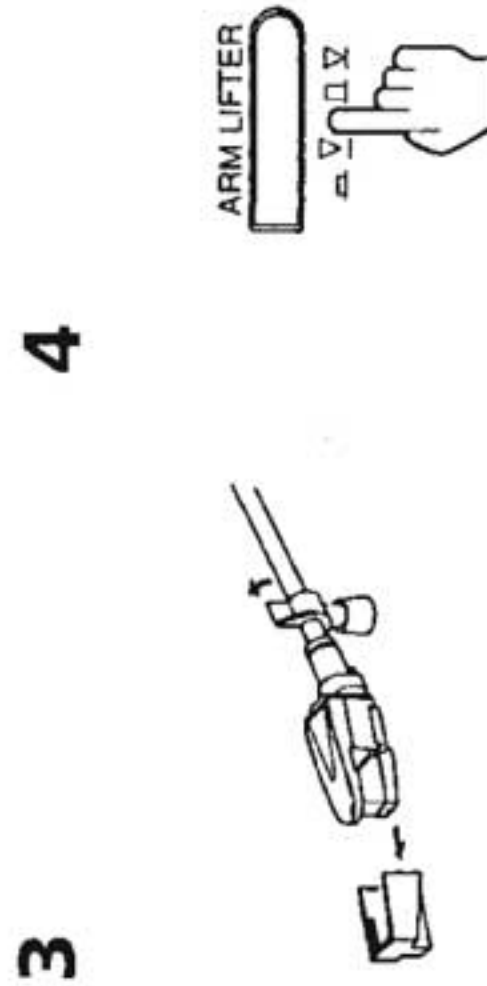
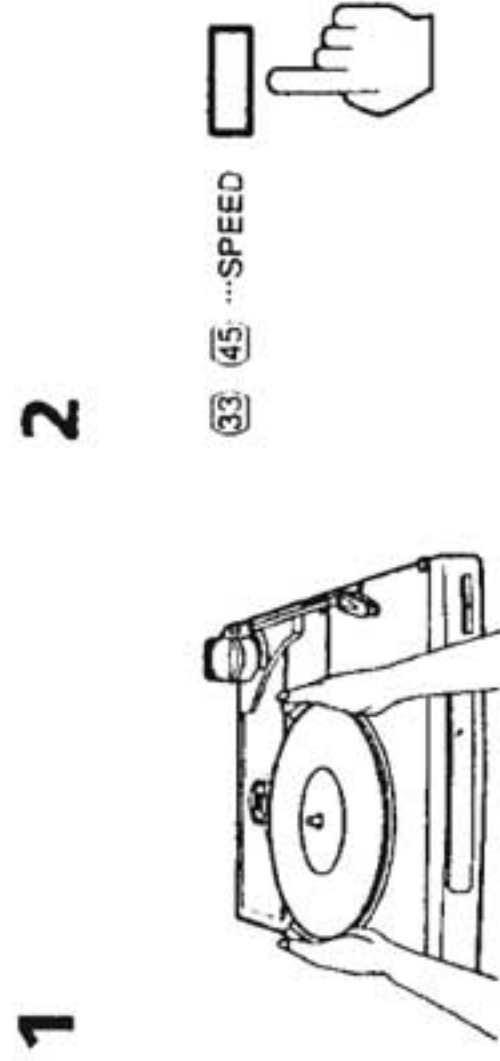

Notes on installation

- Place the turntable on a level surface.
- Avoid placing the unit near electrical appliances (such as a television, hair dryer, or fluorescent lamp) which may cause hum or noise.
- Place the turntable where it will not be subject to any vibration, such as from speakers, slamming of doors, etc.
- Keep the unit away from direct sunlight, extremes of temperature, and excessive dust and moisture.

SECTION 2
DIAGRAMS

2-1. PRINTED WIRING BOARDS

• Semiconductor Location

Ref. No.	Location
D101	C-3
D102	C-2
D103	C-3
D104	C-2
D105	C-2
IC301	C-7
L1	E-2
L2	E-2
Q301	C-7
ZD1	C-7

• Semiconductor Lead Layouts

BA4558N

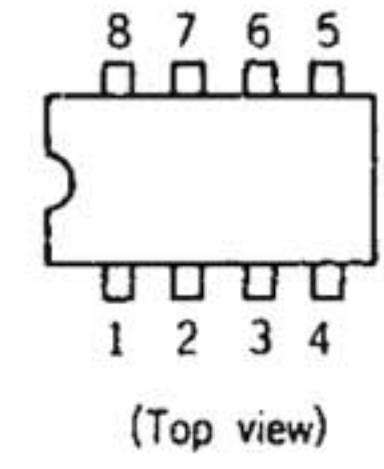

2SC2235

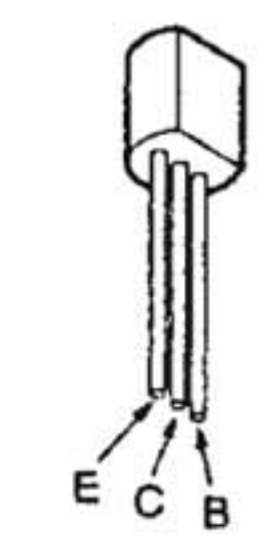

SEL2210R

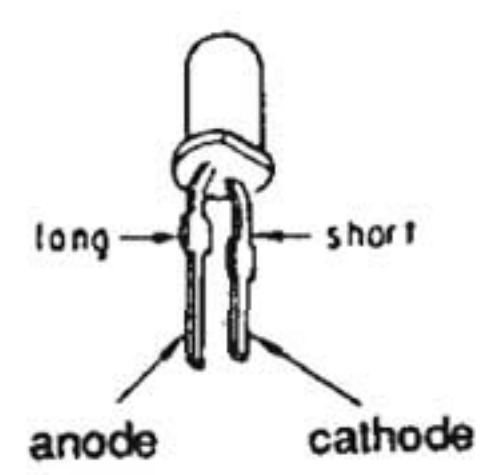

UZL-9M2

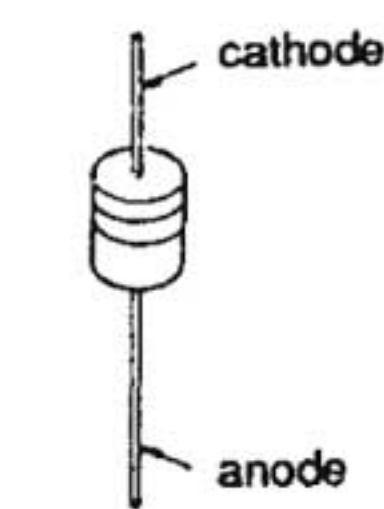

1N4001

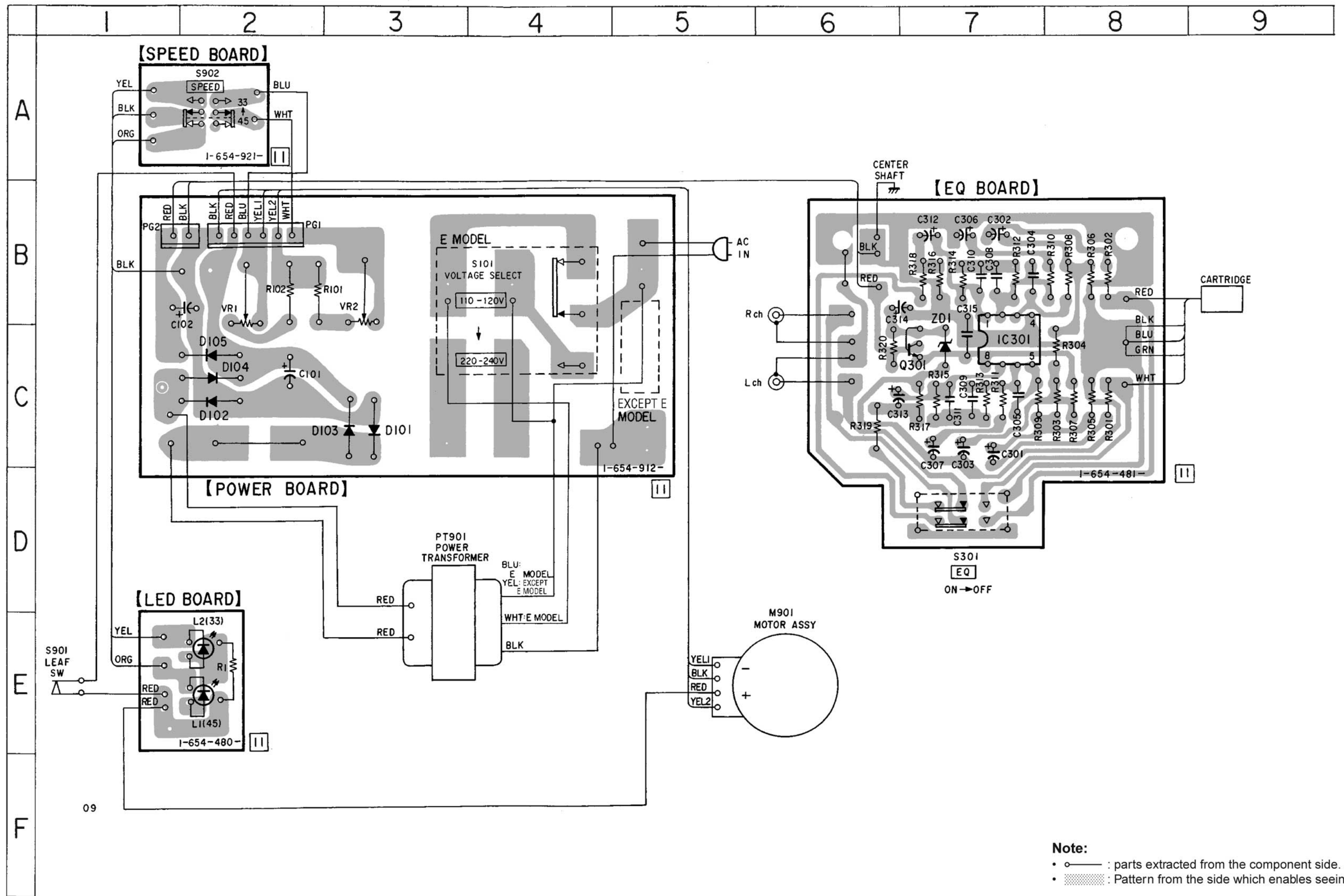
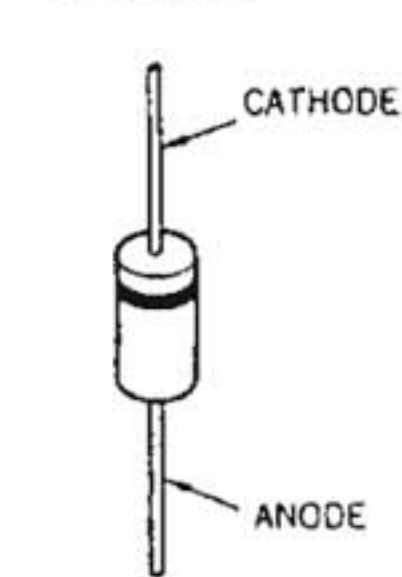

Note:
 • — : parts extracted from the component side.
 • ▨ : Pattern from the side which enables seeing.

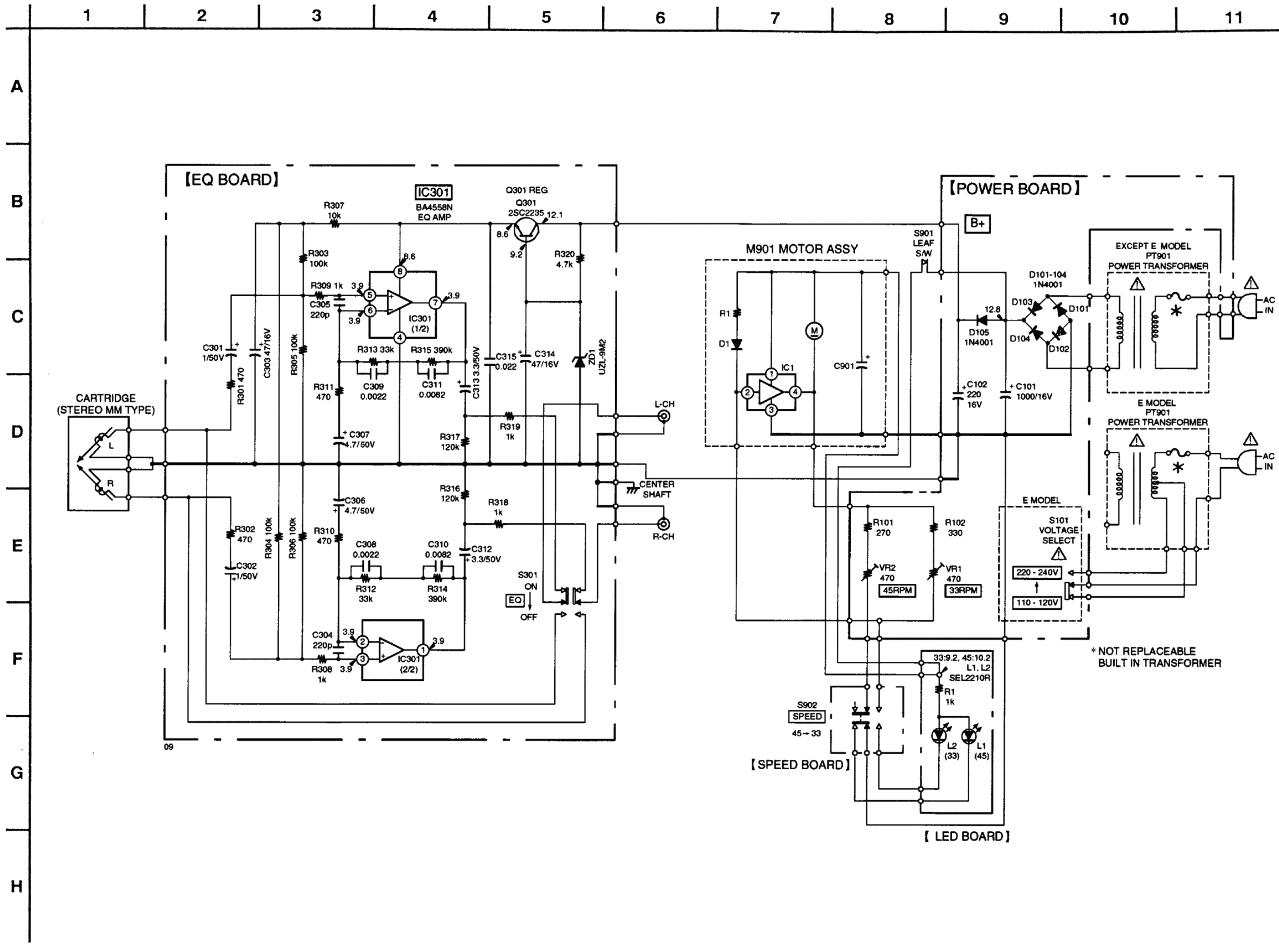

Note:

- All capacitors are in μF unless otherwise noted. pF: $\mu\mu\text{F}$ 50 WV or less are not indicated except for electrolytics and tantalums.
- All resistors are in Ω and $\frac{1}{4}$ W or less unless otherwise specified.

Note:

The components identified by mark Δ or dotted line with mark Δ are critical for safety. Replace only with part number specified.

Note:

Les composants identifiés par une marque Δ sont critiques pour la sécurité. Ne les remplacer que par une pièce portant le numéro spécifié.

- \square : panel designation.
- **B+** : B+ Line.
- \square : adjustment for repair.

- Voltages and waveforms are dc with respect to ground in playback mode.
- Voltages are taken with a VOM (Input impedance 10 M Ω). Voltage variations may be noted due to normal production tolerances.

SPEED ADJUSTMENT

Note: Be sure to perform 33rpm adjustment before 45rpm.

1. Place a stroboscope board on the turntable sheet.
2. Set the speed switch to 33.
3. Set to play mode.
4. Adjust VR1 so that the stripped pattern of stroboscope board is stationary.
5. Set the speed switch to 45. Adjust VR2 in the same way.

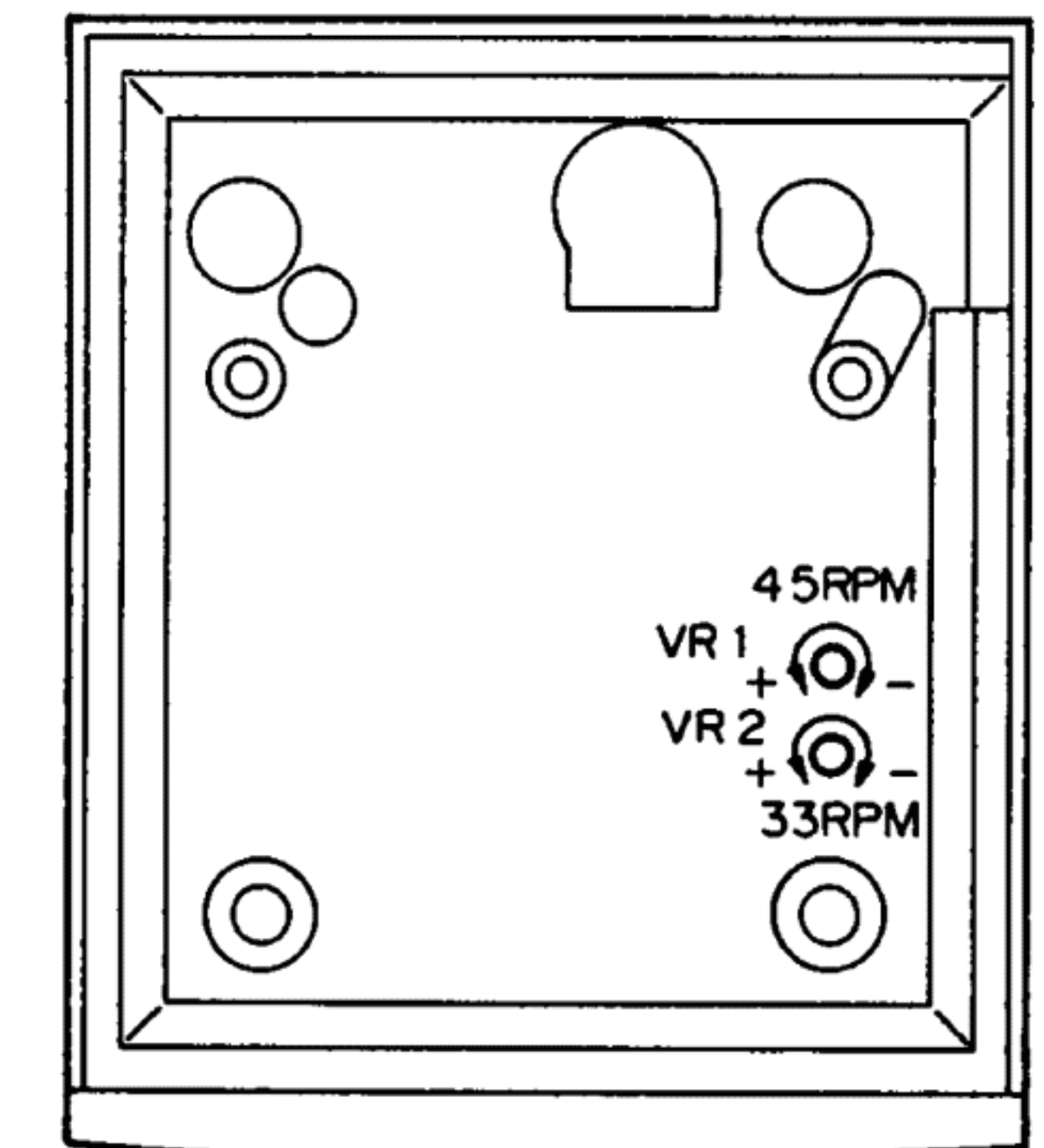

SECTION 3 EXPLODED VIEWS

NOTE:

- -XX, -X mean standardized parts, so they may have some difference from the original one.
- Items marked "*" are not stocked since they are seldom required for routine service. Some delay should be anticipated when ordering these items.

- The mechanical parts with no reference number in the exploded views are not supplied.
- Accessories and packing materials are given in the last of this parts list.
- Abbreviation
CND: Canadian model

The components identified by mark \triangle or dotted line with mark \triangle are critical for safety. Replace only with part number specified.

Les composants identifiés par une marque \triangle sont critiques pour la sécurité.

Ne les remplacer que par une pièce portant le numéro spécifié.

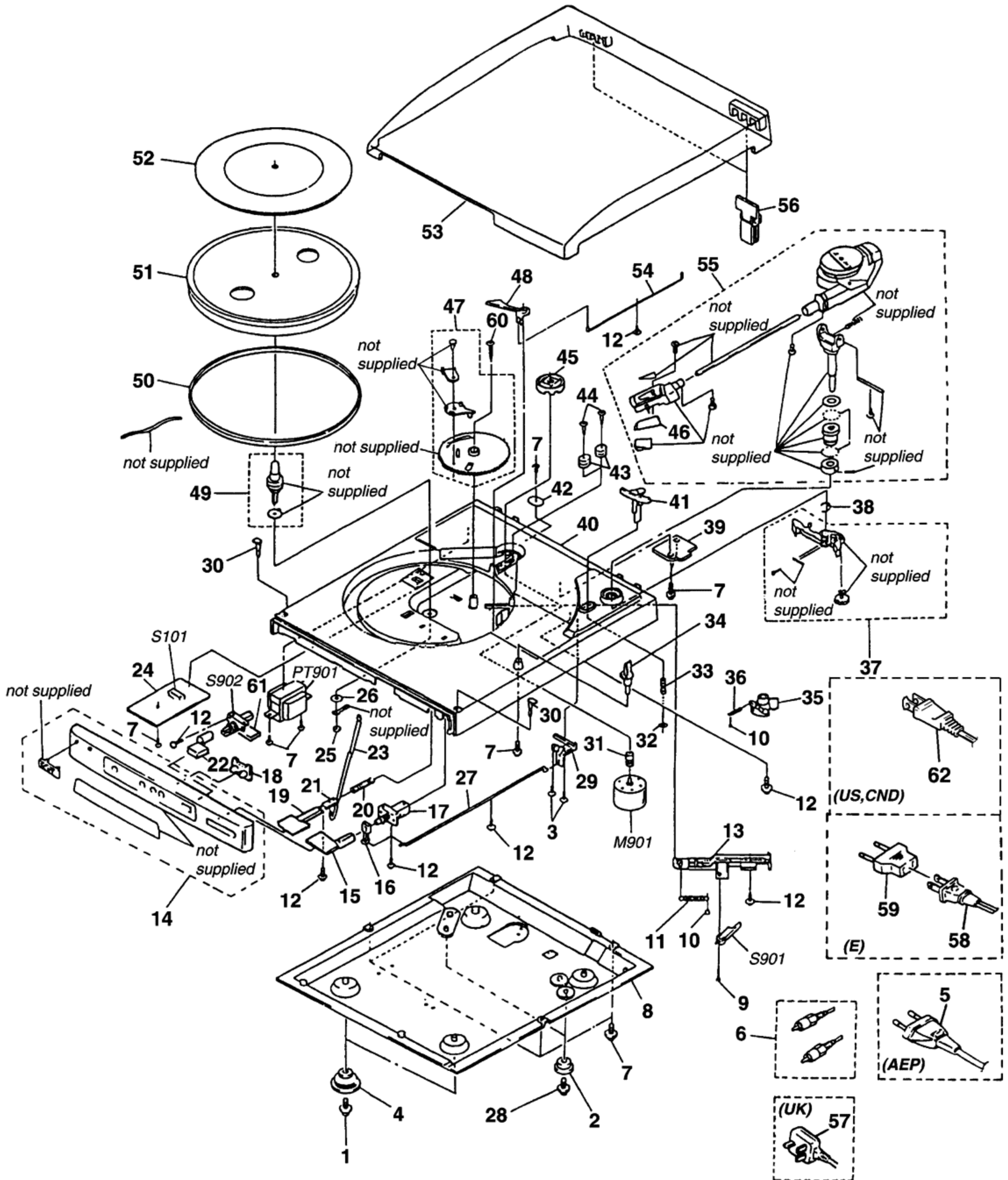

<u>Ref. No.</u>	<u>Part No.</u>	<u>Description</u>	<u>Remark</u>	<u>Ref. No.</u>	<u>Part No.</u>	<u>Description</u>	<u>Remark</u>
* 1	4-970-314-01	FOOT SCREW		* 34	4-970-326-01	ARM STAND	
2	4-970-312-01	RUBBER FOOT		* 35	4-970-301-01	ELEVATOR	
* 3	4-970-328-01	WASHER SCREW TAP WPH		* 36	4-970-305-01	SPRING ELEVATOR	
4	4-970-313-01	RUBBER FOOT		37	A-4660-773-A	ARM ASSY, FEED	
△ 5	1-575-651-11	CORD, POWER (AEP)		* 38	4-970-306-01	E-RING	
6	1-555-116-11	CORD, PHONE		* 39	1-654-481-11	EQ BOARD	
7	4-960-220-01	SCREW TAP WPH		* 40	4-970-290-01	CABINET UPPER (BLACK)	
* 8	4-970-307-01	COVER BOTTOM		* 40	4-970-290-11	CABINET UPPER (SILVER)	
9	4-970-310-01	SCREW TAP WPH		* 41	4-970-295-01	ELEVATION ARM	
* 10	4-970-329-01	STOPPER SPRING		42	4-960-209-01	STOPPER CORD	
* 11	4-970-330-01	ACTUATING ARM SPRING		43	4-960-182-01	CUSHION MOTOR	
12	4-960-217-01	WASHER SCREW TAP WPH		* 44	4-970-325-01	MOTOR SETTING SCREW	
* 13	4-970-298-01	ACTUATING ARM		45	4-970-308-01	ADAPTOR E.P	
14	A-4384-983-A	PANEL ASSY, FRONT (SILVER)		46	4-951-290-01	STYLUS (CN-234)	
14	A-4660-791-A	PANEL ASSY, FRONT (BLACK)		47	A-4660-485-A	RING GEAR ASSY	
15	4-970-322-01	CUE KNOB		* 48	4-970-300-01	CUT LEVER	
* 16	4-970-323-01	CUE LINK HOLDER		49	A-4660-772-A	SHAFT ASSY, CENTER	
17	1-572-744-11	SWITCH, PUSH (1 KEY)(ARM LIFTER)		50	4-960-222-01	BELT RUBBER	
* 18	1-654-480-11	LED BOARD		* 51	4-971-209-01	PLATTER	
19	4-970-294-01	KNOB REJECT (BLACK)		52	4-971-208-01	RUBBER SHEET	
19	4-970-294-11	KNOB REJECT (SILVER)		53	4-970-309-01	COVER DUST	
* 20	4-970-321-01	RETURN		* 54	4-970-299-01	LINK CUT	
* 21	4-970-320-01	HOLDER REJECT		55	A-4660-769-A	ARM ASSY, TONE	
22	4-970-293-01	KNOB SPEED (BLACK)		56	A-4660-774-A	HINGE ASSY	
22	4-970-293-11	KNOB SPEED (SILVER)		△ 57	1-696-570-21	CORD, POWER (UK)	
* 23	4-970-311-01	LINK REJECT		△ 58	1-590-074-11	CORD, POWER (E)	
* 24	1-654-912-11	POWER BOARD		△ 59	1-569-007-11	ADAPTER, CONVERSION 2P (E)	
* 25	4-970-303-01	NUT HEX		60	4-960-218-01	WASHER SCREW TAP WPH	
* 26	4-970-302-01	WASHER PLANE		* 61	1-654-921-11	SPEED BOARD	
* 27	4-970-324-01	QUEING LINK		△ 62	1-777-361-11	CABLE, INTERFACE (MAC) (US, CND)	
* 28	4-970-316-01	SCREW TAP WPH		M901	1-698-210-11	MOTOR	
* 29	4-970-327-01	CUE LEVER		△ PT901	1-427-716-11	TRANSFORMER, POWER (AEP,UK)	
30	4-970-291-01	CUSHION DUST COVER		△ PT901	1-427-857-11	TRANSFORMER, POWER (E)	
31	4-970-304-01	PULLEY MOTOR		△ PT901	1-431-954-11	TRANSFORMER, POWER (US,CND)	
* 32	4-970-297-01	WASHER C.S		△ S101	1-572-675-11	SWITCH, POWER VOLTAGE CHANGE (E)	
* 33	4-970-296-01	SPRING ELEVATION		S901	1-692-692-11	LEAF S/W	
				S902	1-762-224-11	SWITCH, PUSH (SPEED)(1 KEY)	

SECTION 4 ELECTRICAL PARTS LIST

EQ	LED	POWER
-----------	------------	--------------

Note:

The components identified by mark Δ or dotted line with mark Δ are critical for safety. Replace only with part number specified.

Les composants identifiés par une marque Δ sont critiques pour la sécurité. Ne les remplacer que par une pièce portant le numéro spécifié.

When indicating parts by reference number, please include the board name.

- Due to standardization, replacements in the parts list may be different from the parts specified in the diagrams or the components used on the set.
- -XX, -X mean standardized parts, so they may have some difference from the original one.
- Items marked "*" are not stocked since they are seldom required for routine service. Some delay should be anticipated when ordering these items.
- RESISTORS
All resistors are in ohms
METAL: Metal-film resistor
METAL OXIDE: Metal Oxide-film resistor
F : nonflammable
- SEMICONDUCTORS
In each case, u: μ , for example:
uA...: μ A..., uPA...: μ PA..., uPB...: μ PB...,
uPC...: μ PC..., uPD...: μ PD...
- CAPACITORS
uF : μ F
- COILS
uH : μ H
- Abbreviation
CND: Canadian model

Ref. No.	Part No.	Description			Remark	Ref. No.	Part No.	Description			Remark
*	1-654-481-11	EQ BOARD *****				R319	1-249-417-11	CARBON	1K	5%	1/4W F
		< CAPACITOR >				R320	1-247-847-11	CARBON	4.7K	5%	1/4W
C301	1-124-903-11	ELECT	1uF	20%	50V			< SWITCH >			
C302	1-124-903-11	ELECT	1uF	20%	50V	S301	1-762-223-11	SWITCH, SLIDE (EQ)			
C303	1-104-664-11	ELECT	47uF	20%	16V			< DIODE >			
C304	1-102-978-00	CERAMIC	220PF	5%	50V	ZD1	8-719-001-15	DIODE UZL-9M2			
C305	1-102-978-00	CERAMIC	220PF	5%	50V	*****					
C306	1-126-963-11	ELECT	4.7uF	20%	50V	*	1-654-480-11	LED BOARD *****			
C307	1-126-963-11	ELECT	4.7uF	20%	50V			< DIODE >			
C308	1-130-475-00	MYLAR	0.0022uF	5%	50V	L1	8-719-300-71	LED SEL2210R (45)			
C309	1-130-475-00	MYLAR	0.0022uF	5%	50V	L2	8-719-300-71	LED SEL2210R (33)			
C310	1-130-482-00	MYLAR	0.0082uF	5%	50V			< RESISTOR >			
C311	1-130-482-00	MYLAR	0.0082uF	5%	50V	R1	1-249-417-11	CARBON	1K	5%	1/4W F
C312	1-126-962-11	ELECT	3.3uF	20%	50V	*****					
C313	1-126-962-11	ELECT	3.3uF	20%	50V	*	1-654-912-11	POWER BOARD *****			
C314	1-104-664-11	ELECT	47uF	20%	16V			< CAPACITOR >			
C315	1-101-005-00	CERAMIC	22000PF		50V	C101	1-126-942-61	ELECT	1000uF	20%	16V
		< IC >				C102	1-104-666-11	ELECT	220uF	20%	16V
IC301	8-759-989-89	IC BA4558N						< DIODE >			
		< TRANSISTOR >				D101	8-719-200-02	DIODE 10E2			
Q301	8-729-020-80	TRANSISTOR 2SC2235-OY				D102	8-719-200-02	DIODE 10E2			
		< RESISTOR >				D103	8-719-200-02	DIODE 10E2			
R301	1-247-823-31	CARBON	470	5%	1/4W	D104	8-719-200-02	DIODE 10E2			
R302	1-247-823-31	CARBON	470	5%	1/4W	D105	8-719-200-02	DIODE 10E2			
R303	1-249-441-11	CARBON	100K	5%	1/4W			< RESISTOR >			
R304	1-249-441-11	CARBON	100K	5%	1/4W	R101	1-249-410-11	CARBON	270	5%	1/4W
R305	1-249-441-11	CARBON	100K	5%	1/4W	R102	1-249-411-11	CARBON	330	5%	1/4W
R306	1-249-441-11	CARBON	100K	5%	1/4W			< SWITCH >			
R307	1-247-855-31	CARBON	10K	5%	1/4W	Δ S101	1-572-675-11	SWITCH, POWER VOLTAGE CHANGE (E)			
R308	1-249-417-11	CARBON	1K	5%	1/4W F						
R309	1-249-417-11	CARBON	1K	5%	1/4W F						
R310	1-247-823-31	CARBON	470	5%	1/4W						
R311	1-247-823-31	CARBON	470	5%	1/4W						
R312	1-249-435-11	CARBON	33K	5%	1/4W						
R313	1-249-435-11	CARBON	33K	5%	1/4W						
R314	1-247-893-11	CARBON	390K	5%	1/4W						
R315	1-247-893-11	CARBON	390K	5%	1/4W						
R316	1-247-881-00	CARBON	120K	5%	1/4W						
R317	1-247-881-00	CARBON	120K	5%	1/4W						
R318	1-249-417-11	CARBON	1K	5%	1/4W F						

PS-J10

POWER

SPEED

Ref. No.	Part No.	Description	Remark
		< VARIABLE RESISTOR >	
VR1	1-241-760-11	RES, ADJ, CARBON 470	
VR2	1-241-760-11	RES, ADJ, CARBON 470	

*	1-654-921-11	SPEED BOARD *****	
S902	1-762-224-11	SWITCH, PUSH (SPEED) (1 KEY)	

		MISCELLANEOUS *****	
△5	1-575-651-11	CORD, POWER (AEP)	
6	1-555-116-11	CORD, PHONE	
17	1-572-744-11	SWITCH, PUSH (1 KEY)(ARM LIFTER)	
△57	1-696-570-21	CORD, POWER (UK)	
△58	1-590-074-11	CORD, POWER (E)	
△59	1-569-007-11	ADAPTER, CONVERSION 2P (E)	
62	1-777-361-11	CABLE, INTERFACE (MAC)(US,CND)	
M901	1-698-210-11	MOTOR	
△PT901	1-427-716-11	TRANSFORMER, POWER (AEP,UK)	
△PT901	1-427-857-11	TRANSFORMER, POWER (E)	
△PT901	1-431-954-11	TRANSFORMER, POWER (US,CND)	
△S101	1-572-675-11	SWITCH, POWER VOLTAGE CHANGE (E)	
S901	1-692-692-11	LEAF S/W	
S902	1-762-224-11	SWITCH, PUSH (SPEED) (1 KEY)	

		ACCESSORIES & PACKING MATERIALS *****	
△	1-569-007-11	ADAPTER, CONVERSION 2P (E)	
	3-759-639-11	MANUAL, INSTRUCTION (ENGLISH,FRENCH,SPANISH,PORTUGUESE)(US,CND,AEP,UK)	
	3-759-639-41	MANUAL, INSTRUCTION (GERMAN,DUTCH,SWEDISH,ITALIAN)(AEP)	
	3-759-639-51	MANUAL, INSTRUCTION (ENGLISH,FRENCH,SPANISH,CHINESE)(E)	
	4-960-222-01	BELT RUBBER	
*	4-970-333-01	INDIVIDUAL CARTON	
	4-971-208-01	RUBBER SHEET	
*	4-971-209-01	PLATTER	

The components identified by mark △ or dotted line with mark △ are critical for safety. Replace only with part number specified.

Les composants identifiés par une marque △ sont critiques pour la sécurité. Ne les remplacer que par une pièce portant le numéro spécifié.