

PS-X9

*AEP Model
E Model*



STEREO TURN TABLE SYSTEM

SPECIFICATIONS

GENERAL

Power Requirements: 110, 220V ac, 50/60 Hz
Power Consumption: 50W
Dimensions: Approx. 540 (w) x 220 (h) x 450 (d) mm
21 1/4 (w) x 8 5/8 (h) x 17 3/4 (d) inches
Including projecting parts and controls
Weight: Approx. 35 kg, 77 lb 3 oz (net)
Approx. 39 kg, 86 lb (with shipping carton)

TURNTABLE

Platter: 38 cm (15 inches), diecasting aluminum alloy
Motor: Linear BSL (brushless and slotless) dc servo motor
Drive System: Direct drive, crystal lock control system
Speeds: 33 1/3, 45 rpm
Speed Control Range: ±6% (crystal lock OFF)

Starting Characteristics: Comes to nominal speed
Within 1/8 revolution (33 1/3 rpm)
Within 1/5 revolution (45 rpm)

Wow and Flutter: ±0.03% (DIN)
0.02% (WRMS)

S/N Ratio: 75 dB (DIN-B)

Initial Drift: Within 0.0001% (crystal lock ON)

Load Characteristics: 0% up to 1,100 g tracking force

Speed Deviation: Within 0.002% (crystal lock ON)

Automatic System: Arm return reject

TO NEARM

Type: Statically balanced, universal

Pivot to Stylus Length: 264 mm (10 3/8 inches)

Overall Arm Length: 356 mm (14 inches)

Overhang: 14 mm (1/2 inches)

Tracking Error: +1° 45', -1° 18'

Tracking Force Adjustment Range: 0-3 g

Cartridge Weight Range: 10.5-18.5 g (with the small counterweight)
18-33 g (with the large counterweight)

- Continued on page 2 -

SAFETY-RELATED COMPONENT WARNING!!

COMPONENTS IDENTIFIED BY SHADING AND MARK  ON THE SCHEMATIC DIAGRAMS, EXPLODED VIEWS AND IN THE PARTS LIST ARE CRITICAL TO SAFE OPERATION. REPLACE THESE COMPONENTS WITH SONY PARTS WHOSE PART NUMBERS APPEAR AS SHOWN IN THIS MANUAL OR IN SUPPLEMENTS PUBLISHED BY SONY.

SONY®

SERVICE MANUAL

7-2-78

CARTRIDGE XL-55 PRO

Type: Moving-coil
Output Voltage: 0.2 mV (1 kHz, 5 cm/sec, 45°)
Frequency Response: 10–50,000 Hz
Channel Separation: More than 30 dB (1 kHz)
Channel Balance: Less than 1.0 dB (1 kHz)
DC Resistance: 40 Ω
Impedance: 40 Ω (1 kHz)
Load Impedance: More than 40 Ω
Compliance: 15 × 10⁻⁶ cm/dyne
Tracking Force: 1.5–2.5 g (recommended value 2.0 g)
Type of Stylus: Elliptical (0.3 × 0.8 mil)
 Nude diamond
Weight: 22 g (including the shell)

AUDIO SECTION

System: Head amplifier
 first stage LEC transistor differential amplifier
 Equalizer amplifier
 first stage direct-coupled dual-FET differential amplifier, NF type
 final stage SEPP

Outputs: PHONO
 LINE OUT
 voltage 150 mV (max. 14 V)
 impedance 600 Ω

HEAD AMPLIFIER + EQUALIZER AMPLIFIER

S/N Ratio: 80 dB (A weighting network, 0.2 mV)
Harmonic Distortion: Less than 0.005% at 1 V output
 (20–20,000 Hz)
Voltage Gain: 63 dB (1 kHz)
Input Impedance: 100 Ω
Maximum Input Capability: 10 mV

EQUALIZER AMPLIFIER

S/N Ratio: 87 dB (A weighting network, 2.5 mV)
Harmonic Distortion: Less than 0.005% at 1 V output
 (20–20,000 Hz)
RIAA Curve Deviation: 20–20,000 Hz ± 0.2 dB
Voltage Gain: 36 dB (1 kHz)
Input Impedance: Load resistance 25 kΩ, 50 kΩ, 100 kΩ
 (selectable)
 Load capacitance 100 pF, 200 pF, 400 pF
Maximum Input Capability: 240 mV (1 kHz)

SERVICING NOTE

INVERTER CIRCUIT TRANSISTOR REPLACEMENT (Q1503–1506)

CAUTION

When replacing Q1503–1506 in the pulse power-supply circuit, use those which have the same hFE rank.

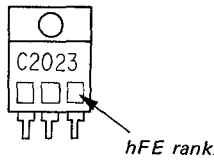

28.12

SECTION 1
BLOCK DIAGRAM

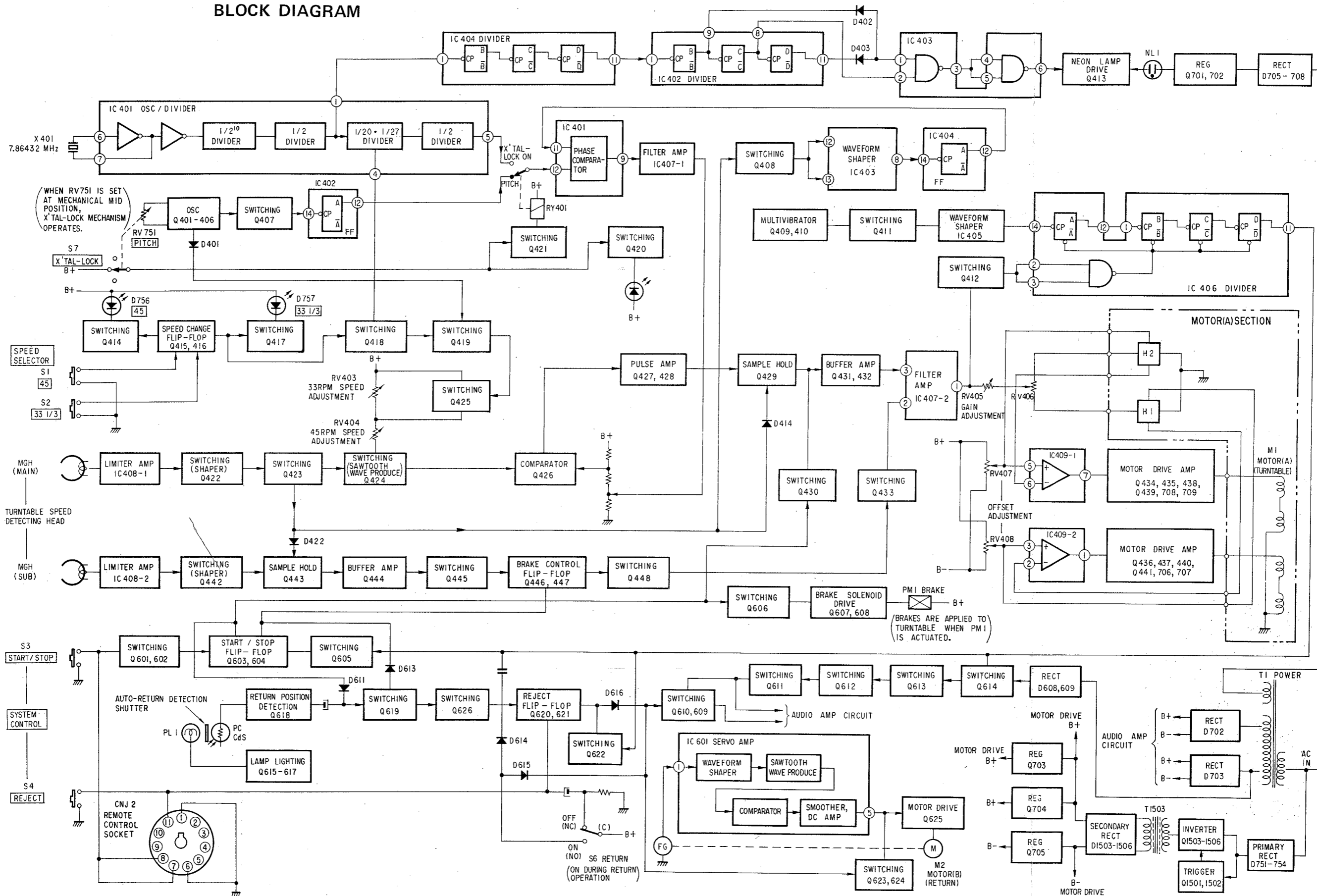

SECTION 2
DISASSEMBLY AND INSTALLATION

Note: Follow the disassembly procedure in the numerical order given.

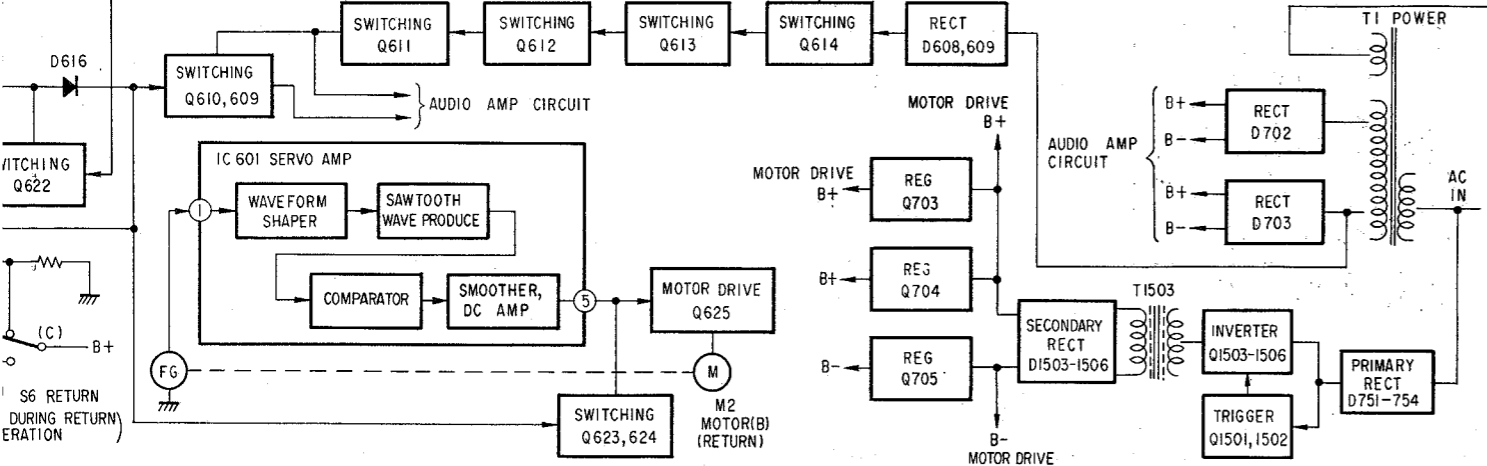
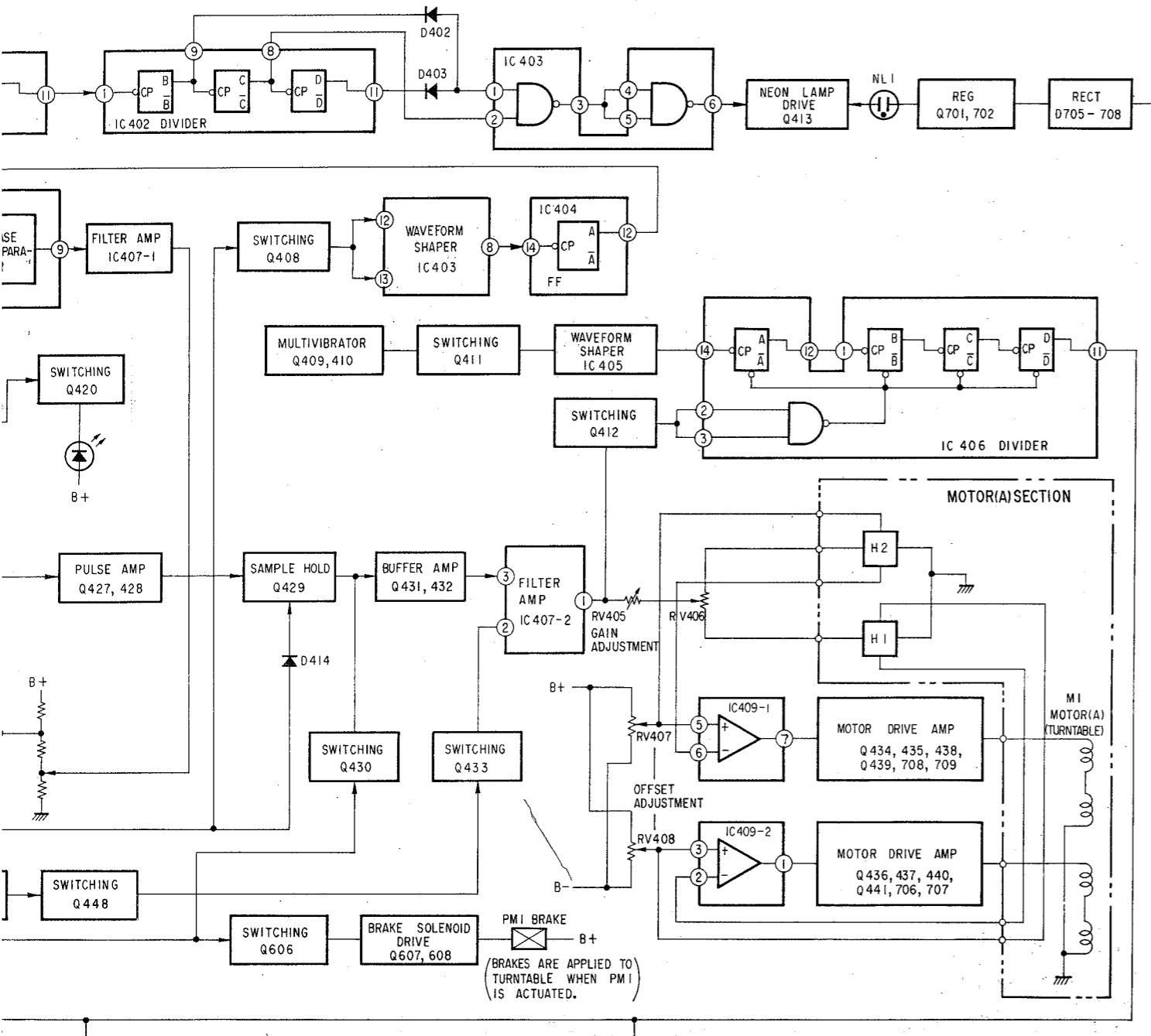

TURNTABLE REMOVAL

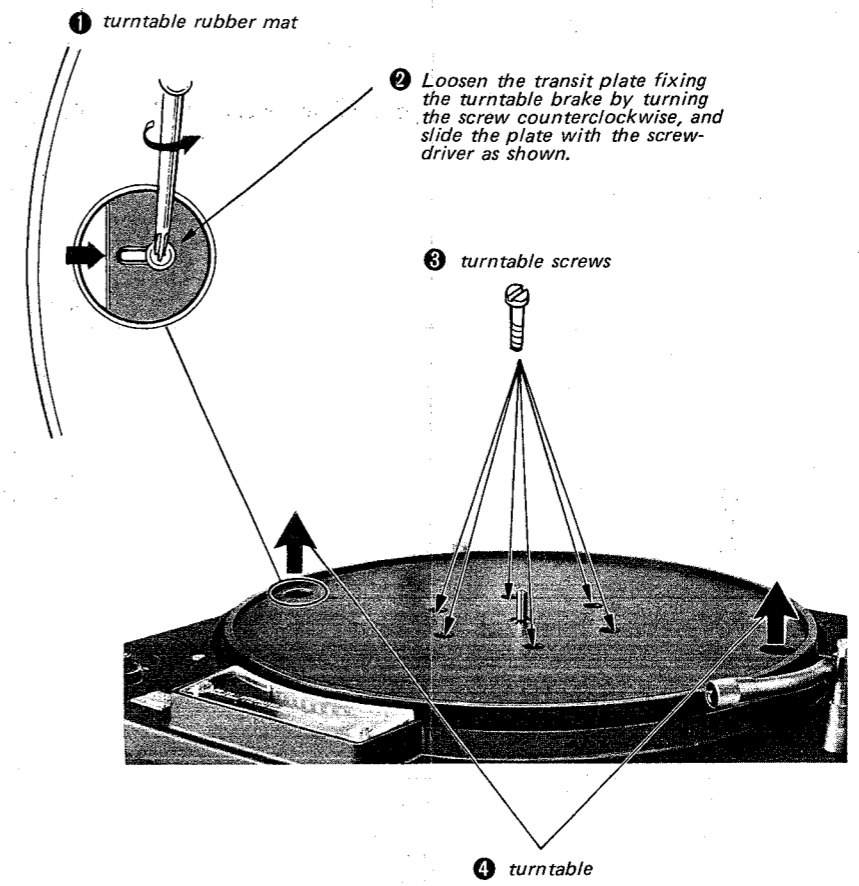

NOTE ON THE TURNTABLE ASSEMBLY

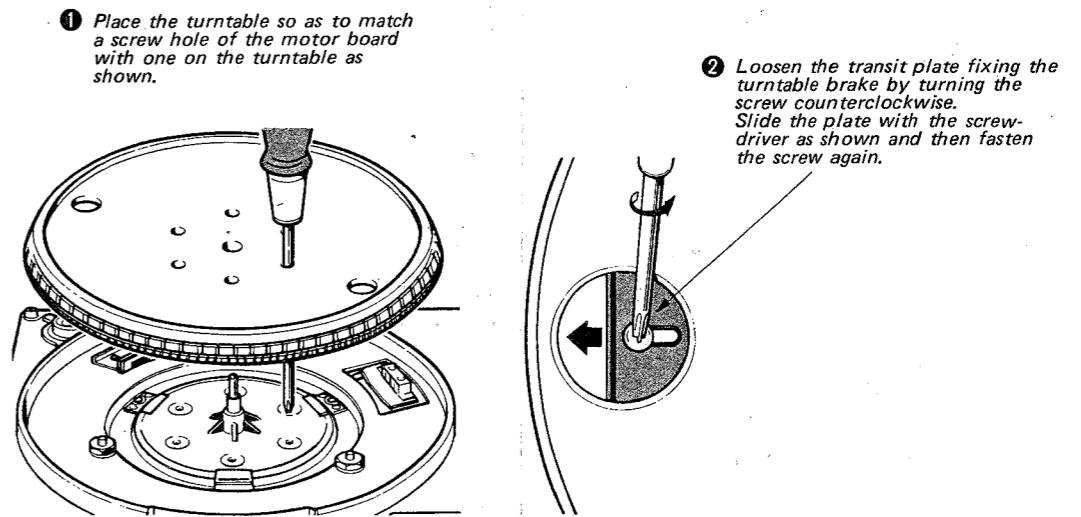

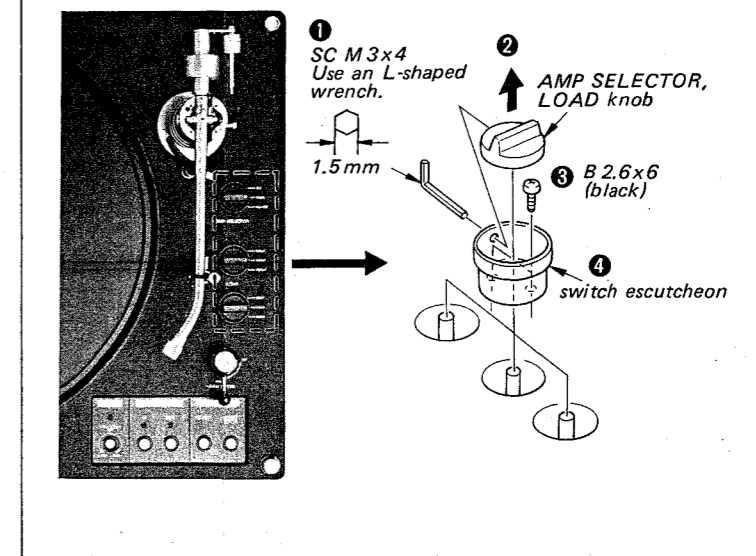
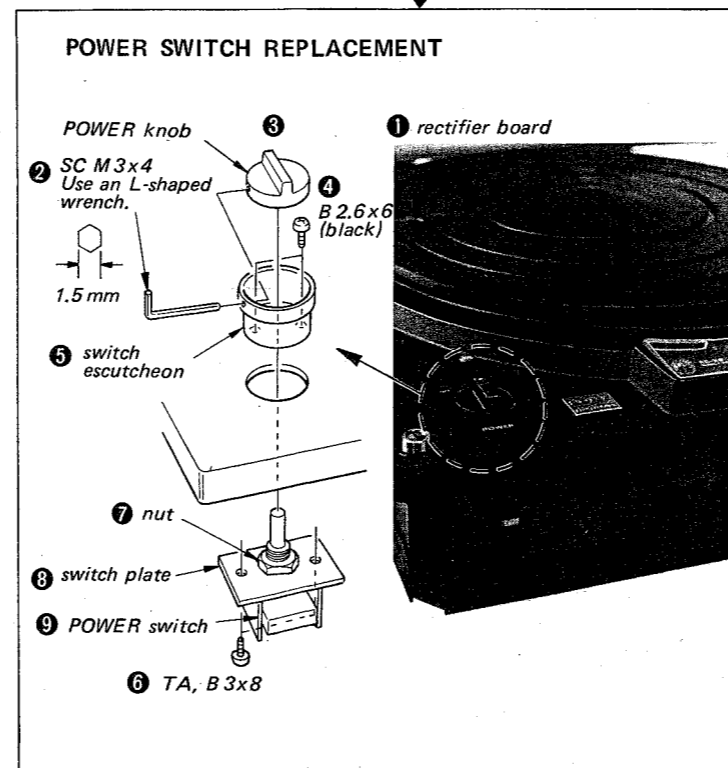
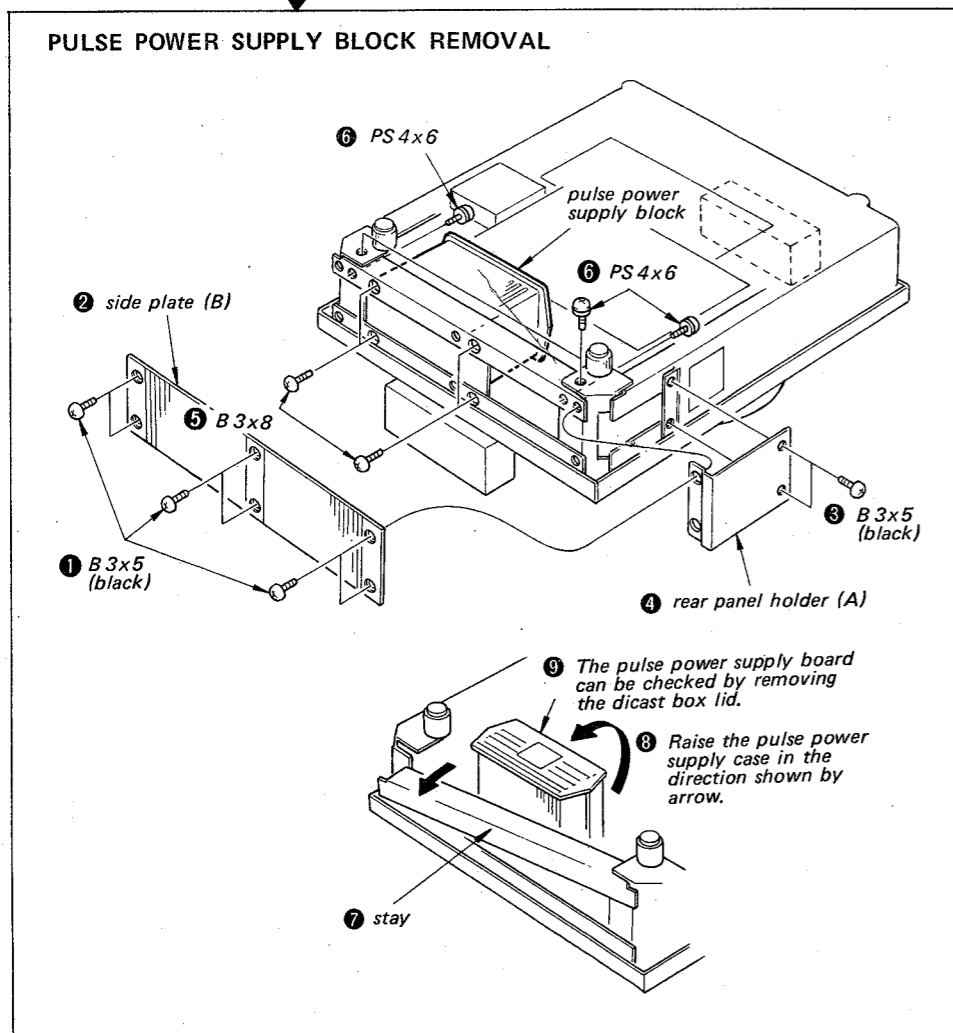
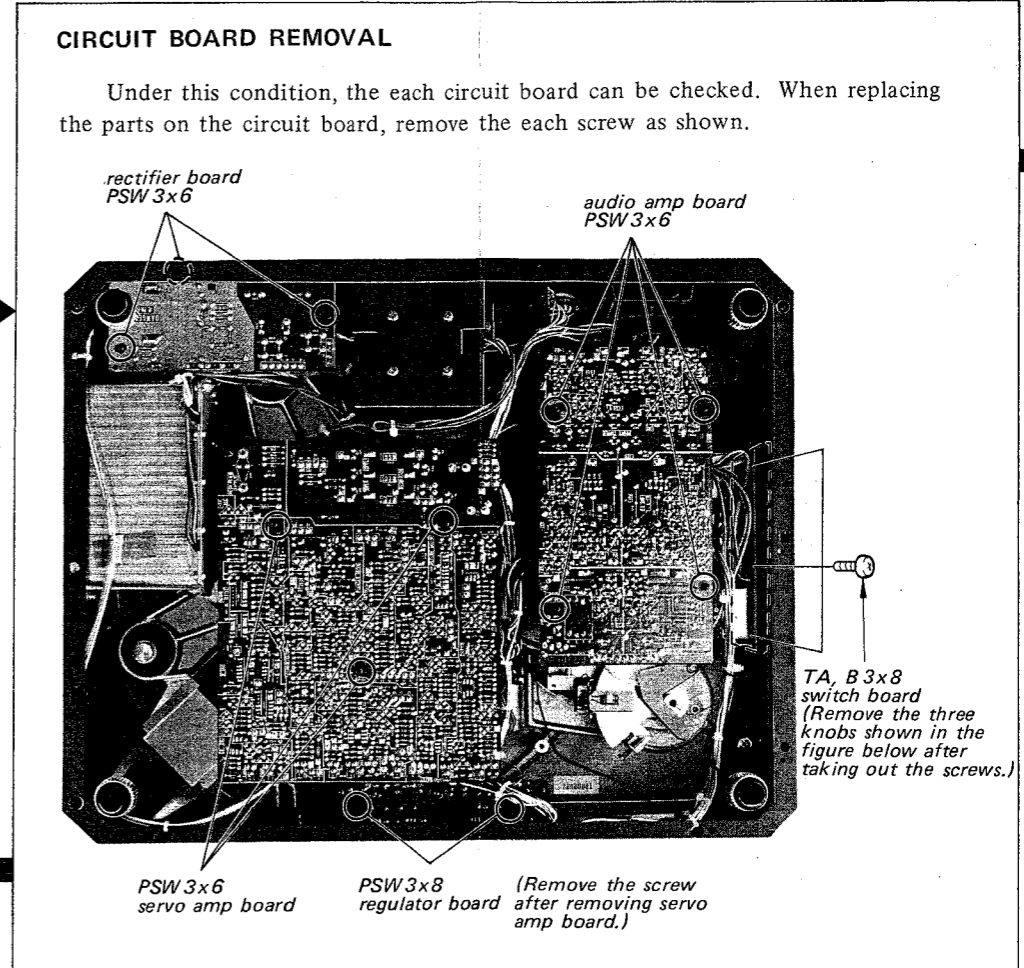
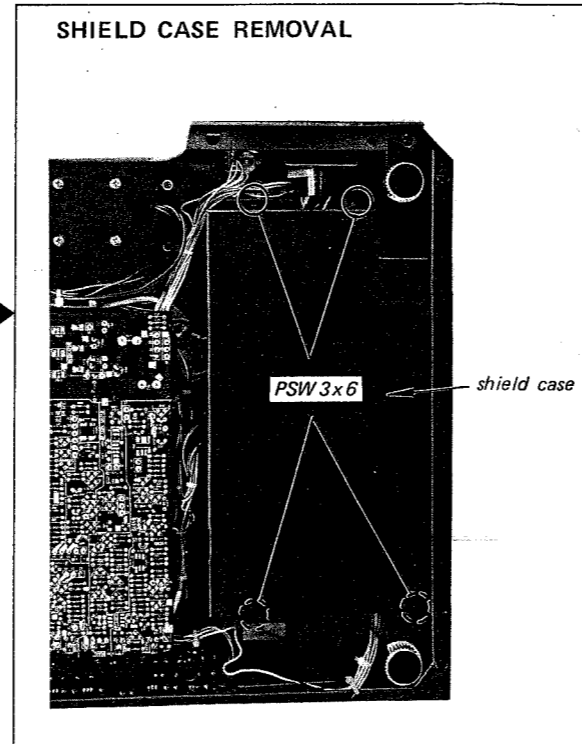
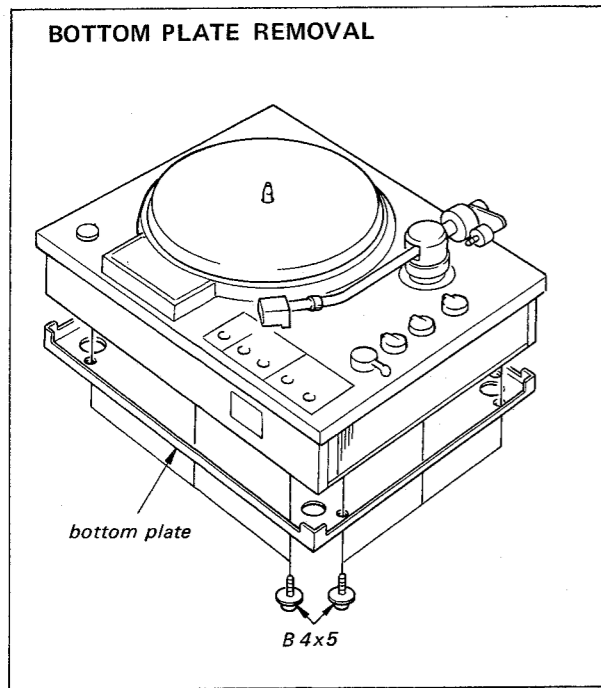

CIRCUIT BOARD REMOVAL

Under this condition, the each circuit board can be checked. When replacing the parts on the circuit board, remove the each screw as shown.

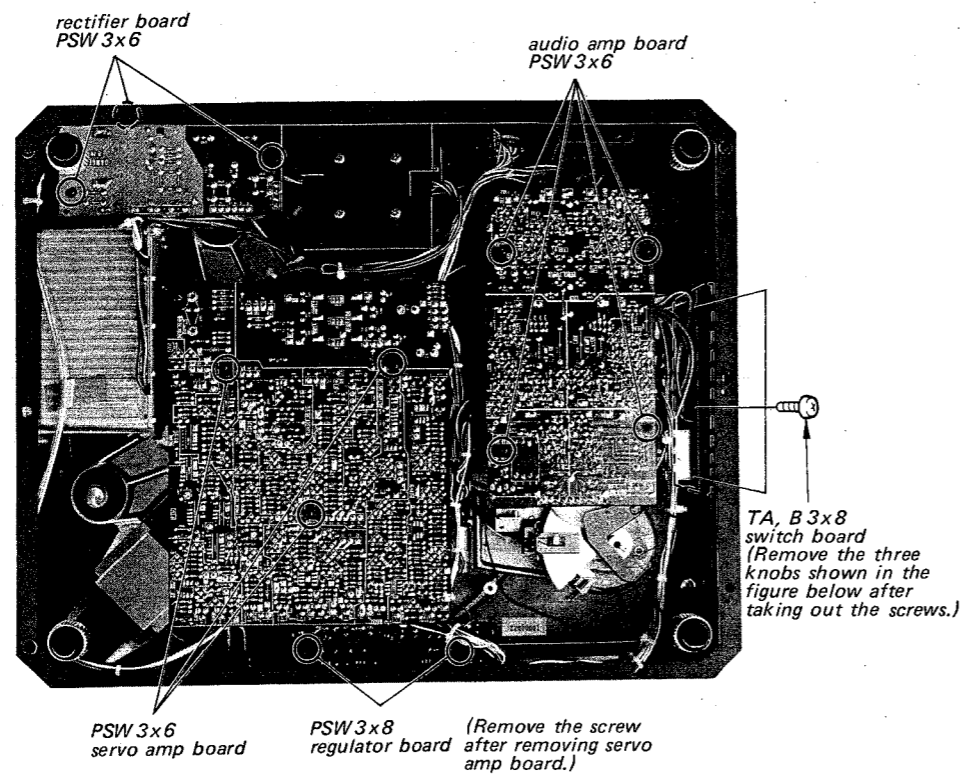

TONEARM REMOVAL

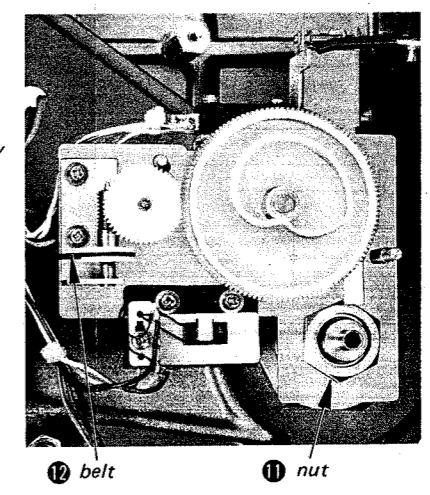
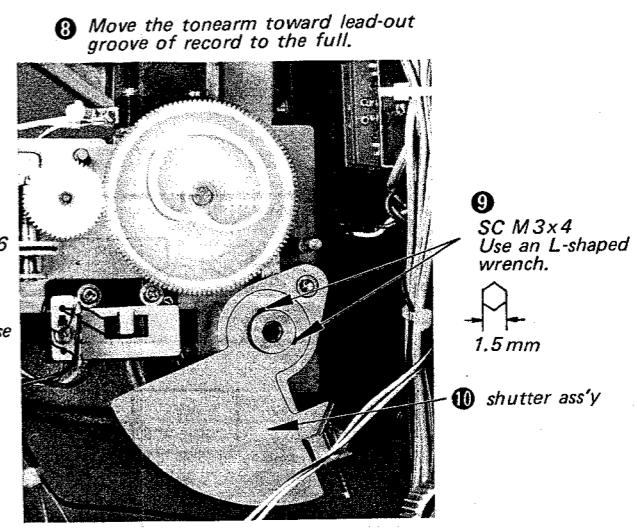
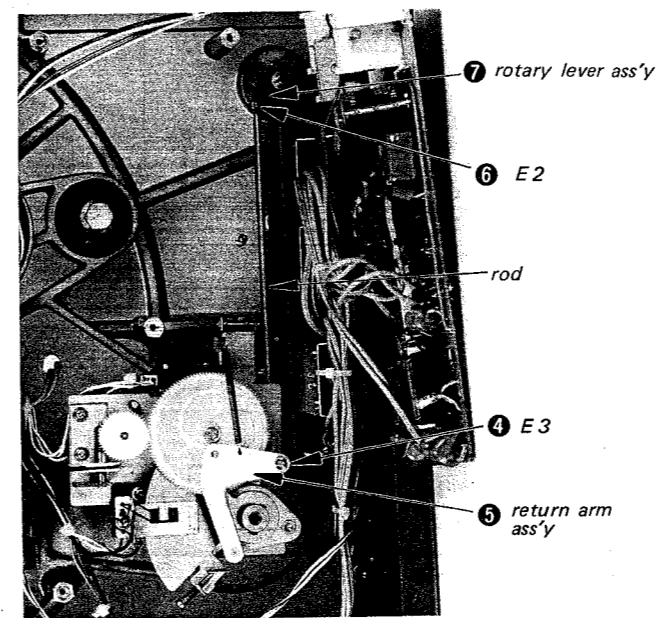
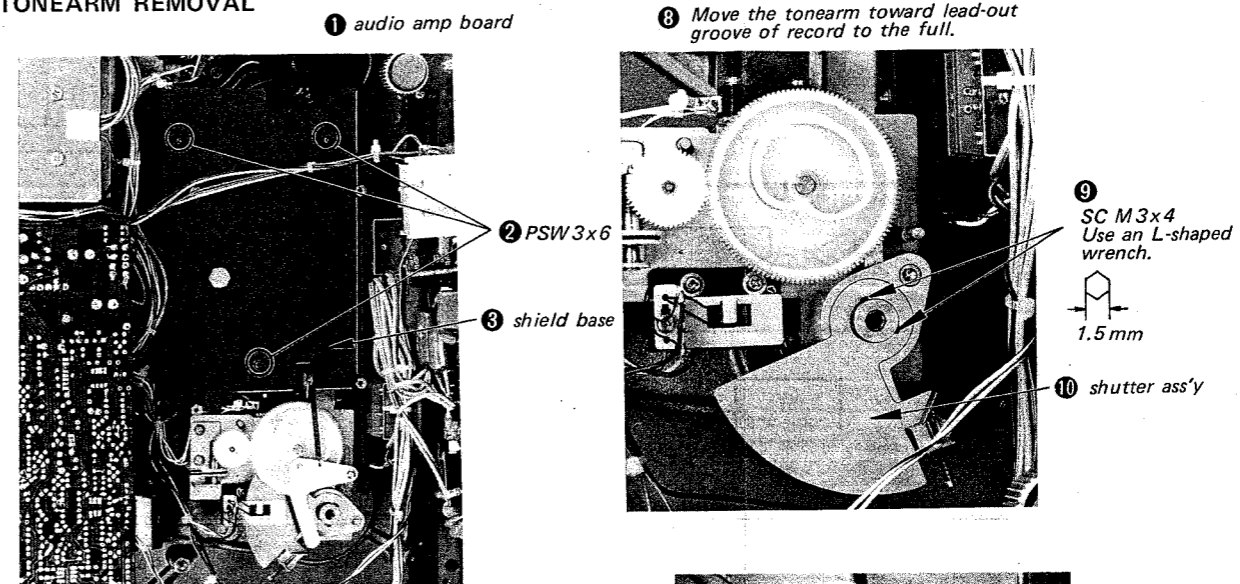

H REPLACEMENT

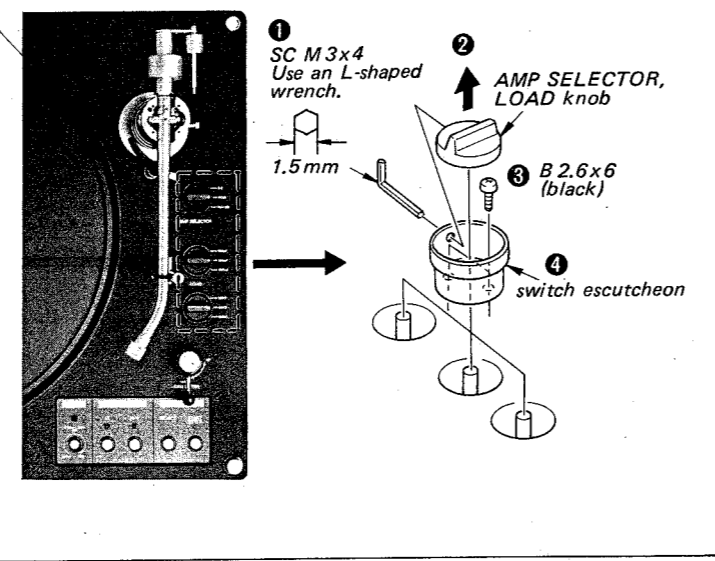
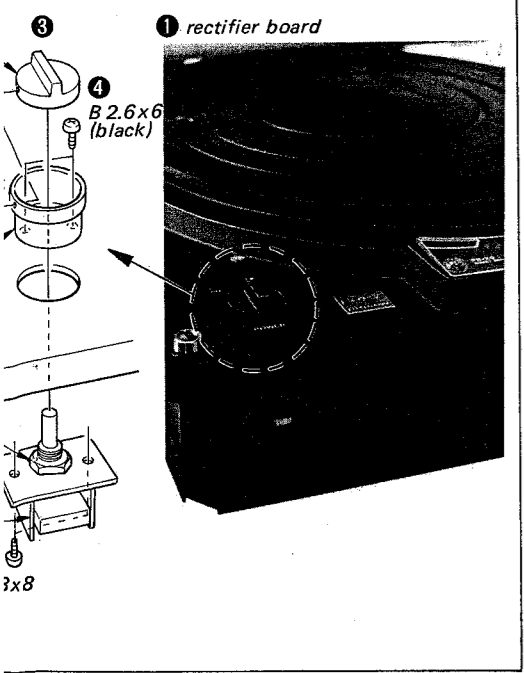

STROBOSCOPE NEON LAMP REPLACEMENT

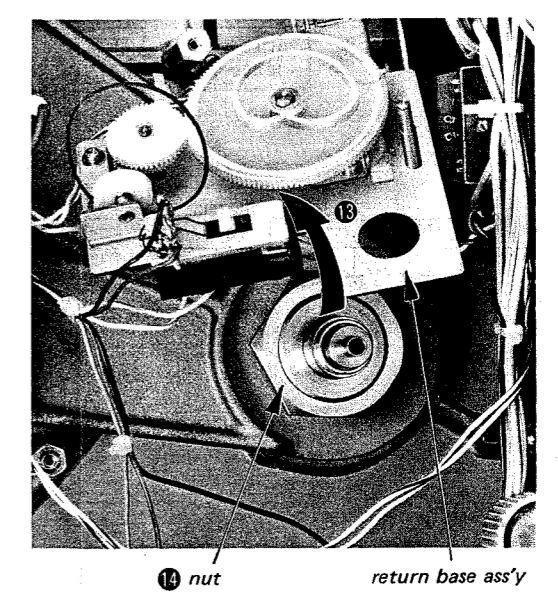
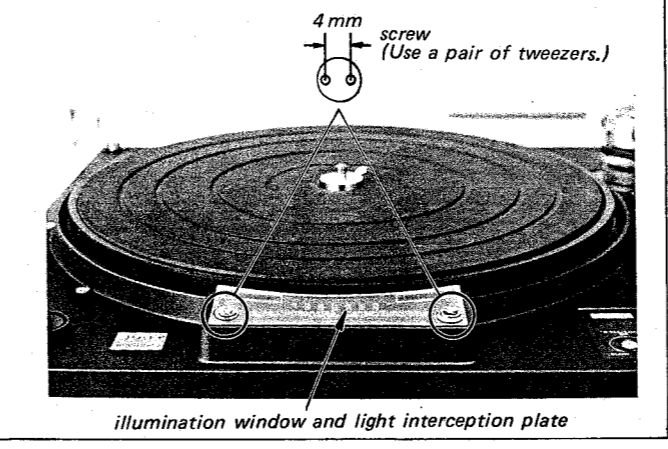

The tonearm can be removed by performing step 15.

TONEARM INSTALLATION

1. Install the lifter ass'y as shown.
2. Insert the shaft (*1) into the hole (*2).
3. Install the nut to the tonearm shaft.

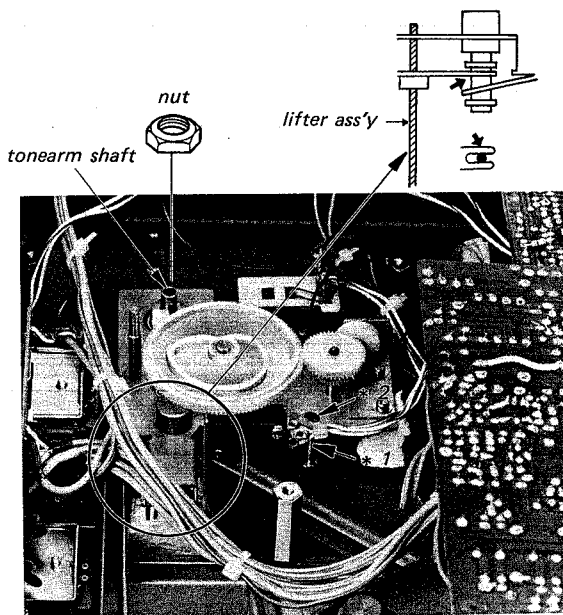

4. Install the belt.
5. Make sure that the motor pulley is even with the worm ass'y.

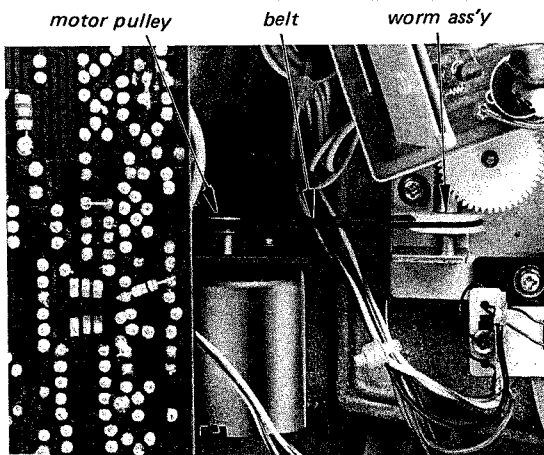

6. Adjust the tonearm so that clearance A is equal to B in the figure below.
7. Turn the shutter adjustment screw clockwise by half a turn.
8. When moving the tonearm toward the lead-out groove of record to the full, turn the screw so that CdS is parallel with shutter ass'y.
9. Temporarily, set the shutter ass'y with a screw (SC M 3x4).
10. Make the automatic-return adjustment on page 15.

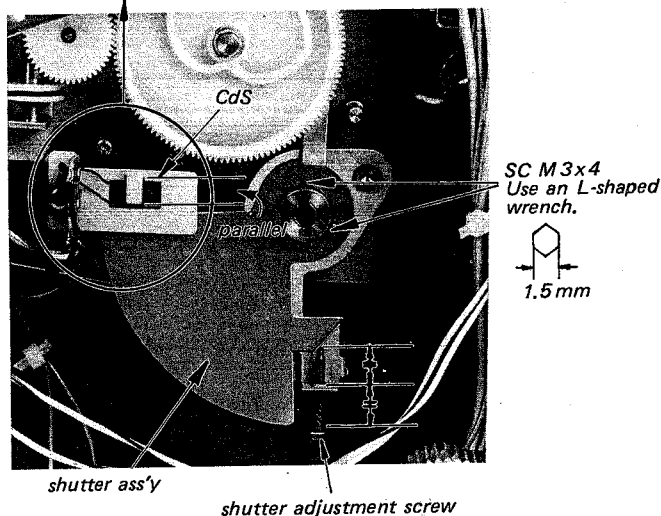
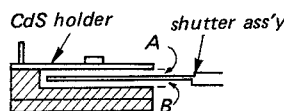

11. Install the return arm ass'y. Make sure that the shaft (*4) is inserted into the bearing (*3).

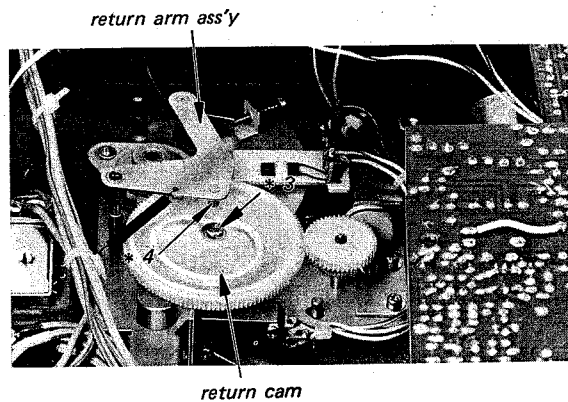

TONEARM BLOCK DISASSEMBLY

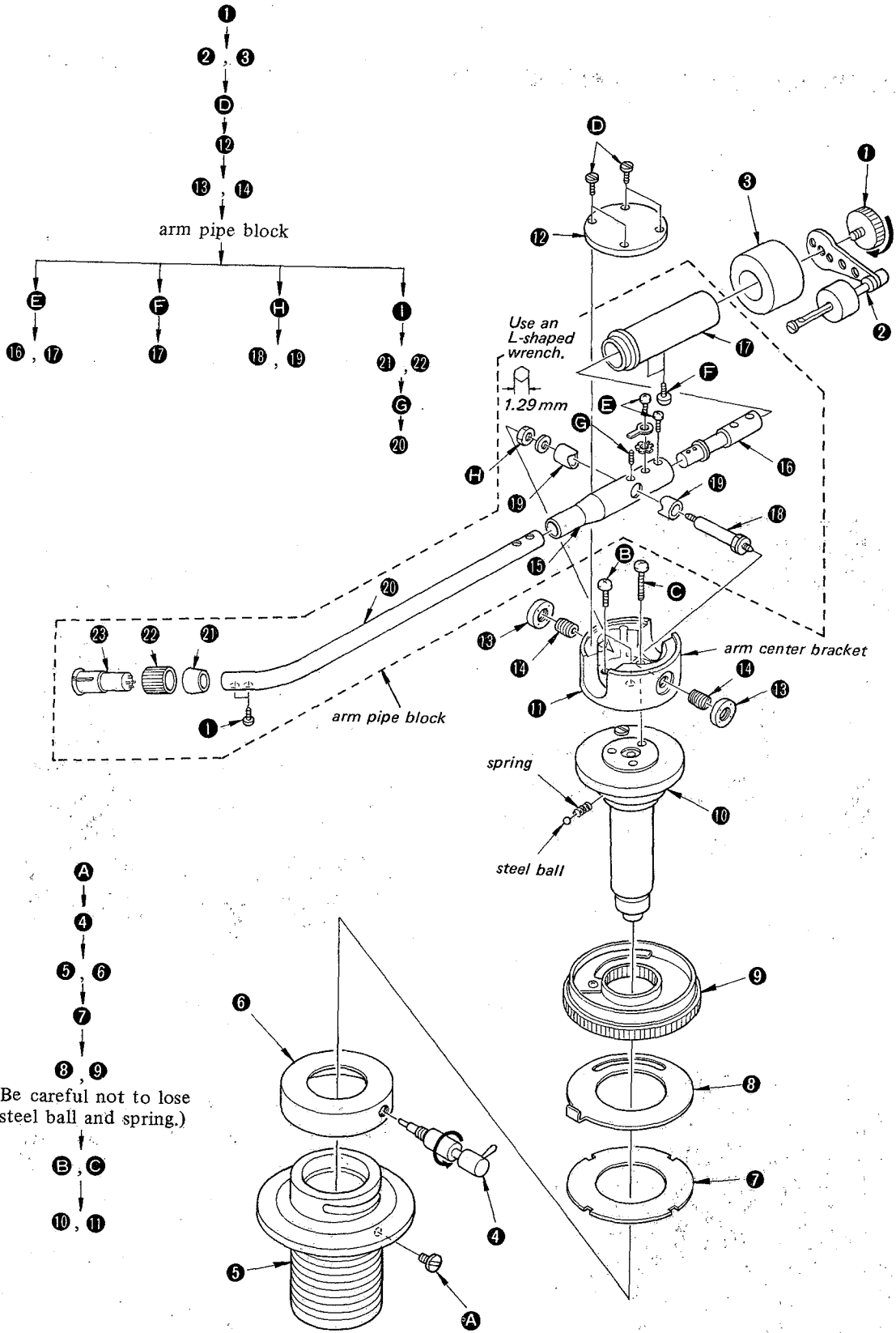

ONEARM BLOCK ASSEMBLY

1. Thread the lead wires into the arm pipe.
(Refer to Fig. 1.)

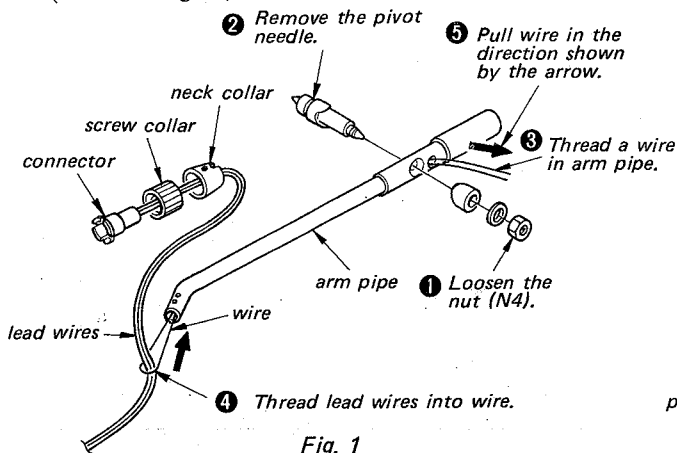

Fig. 1

2. Install the neck-cylinder connector, screw collar and neck collar to the arm pipe. (Refer to Fig. 2.)

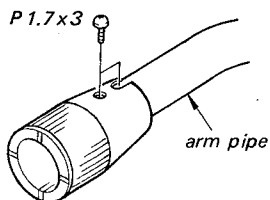

Fig. 2

3. Thread the lead wires into the rotation shaft ass'y. (Refer to Fig. 3.)

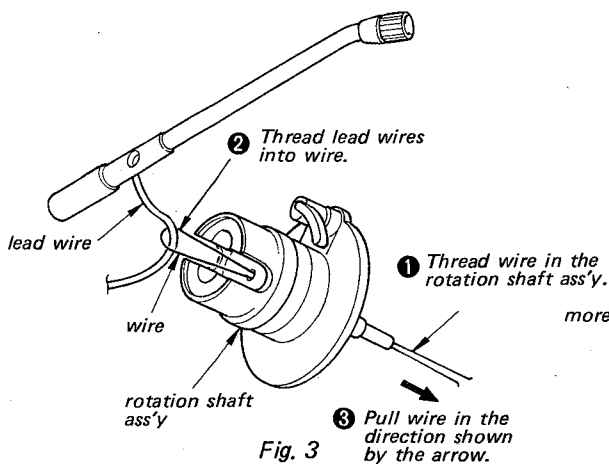

Fig. 3

4. Install the pivot needle.

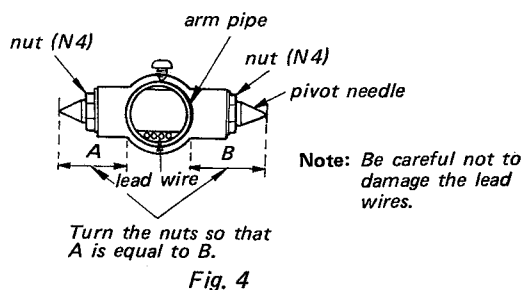

Fig. 4

5. Install the arm pipe to the rotation shaft ass'y.
 - 1) Loosen the pivot bearings and lock nuts.
 - 2) Install the pivot needle as shown in Fig. 5. Temporarily, secure the two bearings for A = B as shown in Fig. 6. Do not tighten the two bearings strongly.

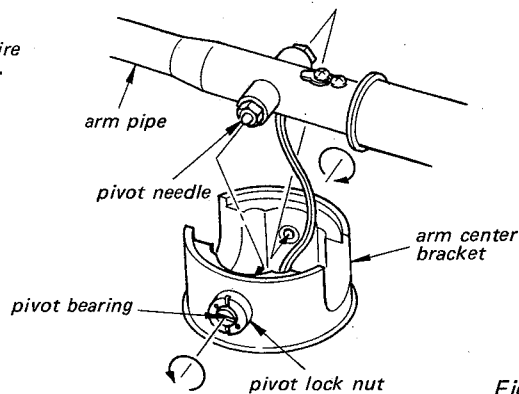

Fig. 5

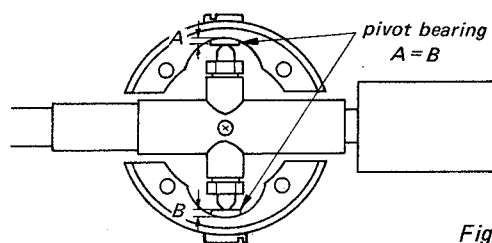

Fig. 6

- 3) Install the tonearm, and make the balance adjustment with the two bearings. (Refer to Fig. 7 and Fig. 8.)
 - a. When the 20 mg weight is placed on the top of the shell (just above a stylus), the tonearm sinks more than 3 mm (measured at the stylus tip).
 - b. When the weight is removed, the tonearm returns horizontally.

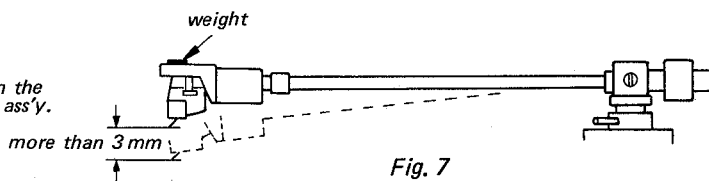

Fig. 7

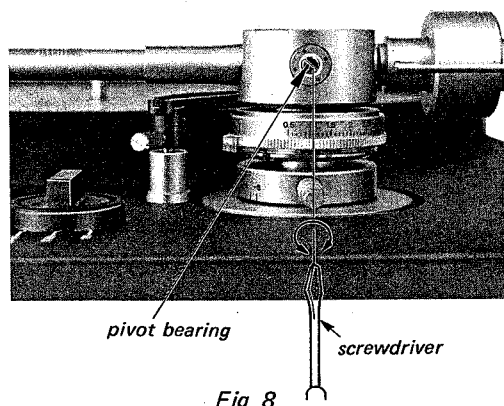

Fig. 8

SECTION 3 ADJUSTMENTS

3-1. MECHANICAL ADJUSTMENT

LIFTER PLATE HEIGHT ADJUSTMENT

1. Bring the tonearm above the record.
2. Set the arm lifter to UP position.
Make sure that the distance between the record and the stylus is 5–9 mm ($\frac{3}{16}$ – $\frac{3}{8}$ inches).
3. If necessary, adjust the height of arm lifter by loosening the lifter knob.

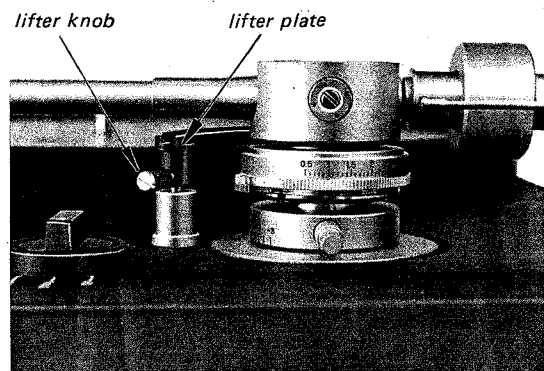
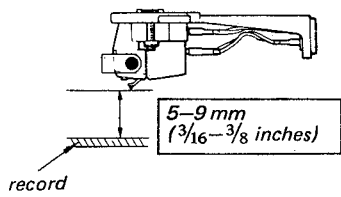

3-2. ELECTRICAL ADJUSTMENTS

SPEED DETECTING HEAD (MGH) POSITION ADJUSTMENT

Make this adjustment when replacing the speed detecting head and the turntable.

The improper adjustment will result in wow and flutter and mis-operation of servo control.

1. Remove the turntable. (Refer to page 5.)
2. Temporarily, secure the head bracket (with head mounted) to the frame.
3. Stick a visiting card (0.3 mm in thickness) on the magnet-coated rim as shown in Fig. 9 (a).
4. Install the turntable described on page 5.
5. Bring the head above the visiting card as shown in Fig. 9 (b).
Adjust the position of head bracket so that the two heads touch the visiting card at the center of head slightly as shown in Fig. 9 (b).

6. Remove the turntable gently. Fix the two head bracket screws.
7. Remove the visiting card and install the turntable. Make sure that the two heads do not touch the magnet-coated rim.
8. Turn on the POWER switch and rotate the turntable at 33 rpm.
9. Connect an oscilloscope across the head as shown in Fig. 11.
10. Make sure that the waveform on the oscilloscope is shown in Fig. 10.
11. Adjust the two screws (*1) when phase difference is improper, and the two screws (*2) when output voltage is improper. (Refer to Fig. 9 (b).)

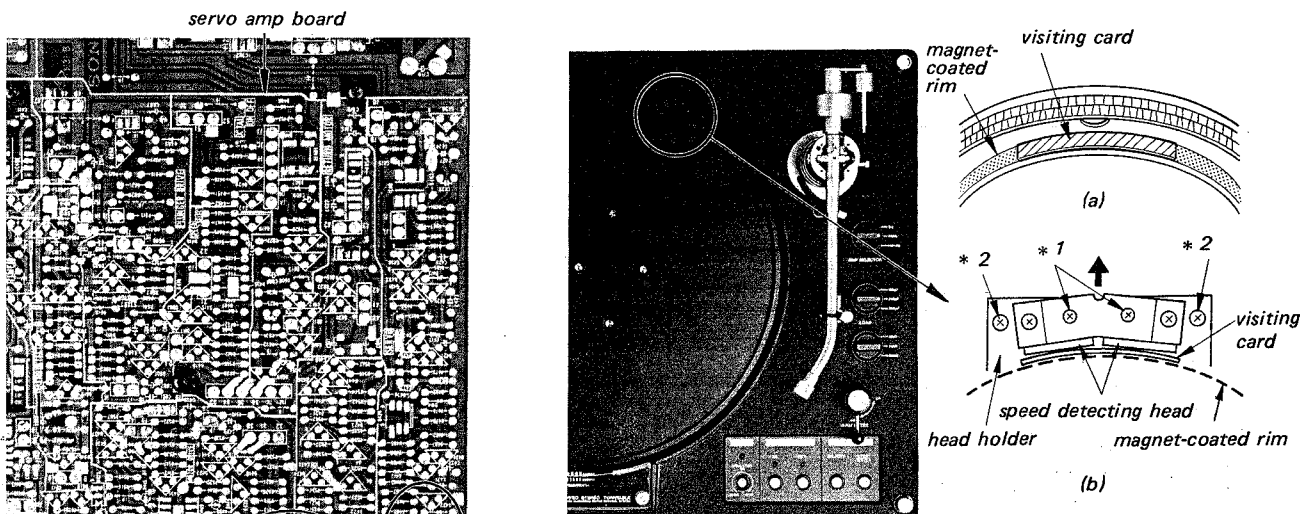

Fig. 9

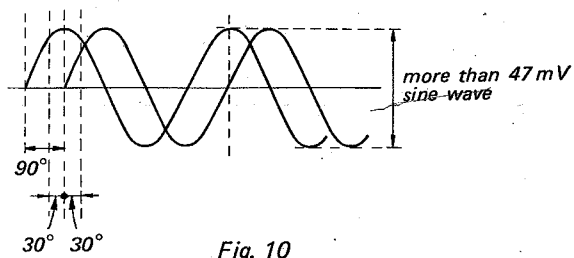

Fig. 10

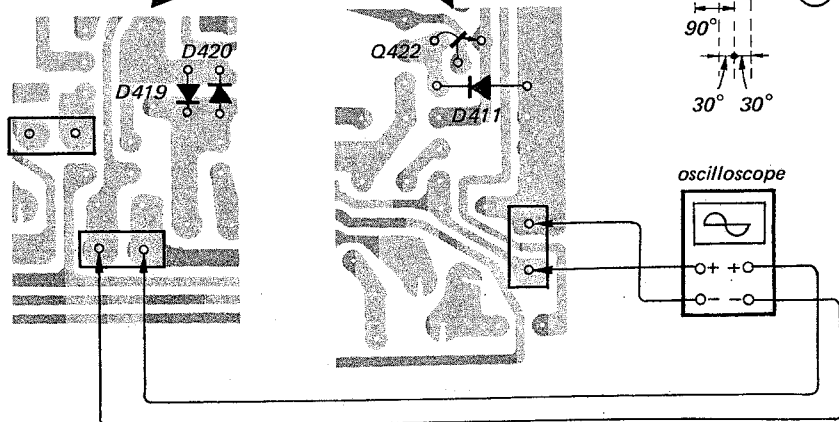
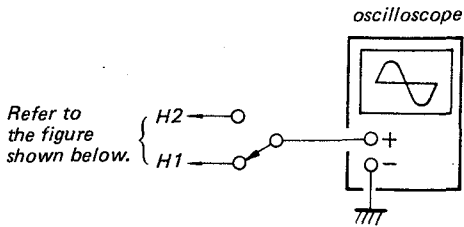

Fig. 11

HALL DEVICE GAIN ADJUSTMENT (33 1/3 rpm)

1. Disconnect the jumper wire, and supply 1V dc as shown in Fig. 14.
2. Connect an oscilloscope to H1 and adjust RV405 and RV406 for 6Vp-p on the oscilloscope.
3. Connect an oscilloscope to H2 and adjust RV405 and RV406 for 6Vp-p on the oscilloscope.
4. Repeat the steps 2 and 3 two or three times.



Note: Set the sweep time longer for easy checking the waveform.

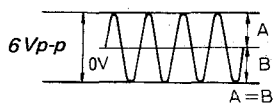
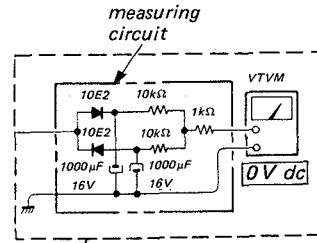

Fig. 12

MOTOR AMP OFFSET ADJUSTMENT (33 1/3 rpm)

1. Disconnect the jumper wire, and supply 1V dc as shown in Fig. 14.
2. Connect a VTVM (or oscilloscope) to H1 and adjust RV407 for 0V dc reading on the VTVM (for waveform shown below when using oscilloscope).
3. Connect a VTVM (or oscilloscope) to H2 and adjust RV408 for 0V dc reading on the VTVM (for waveform shown below when using oscilloscope).



or

Note: Set the sweep time longer for easy checking the waveform.

Refer to the figure shown below.

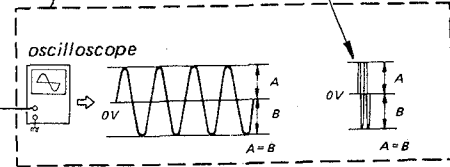
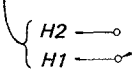
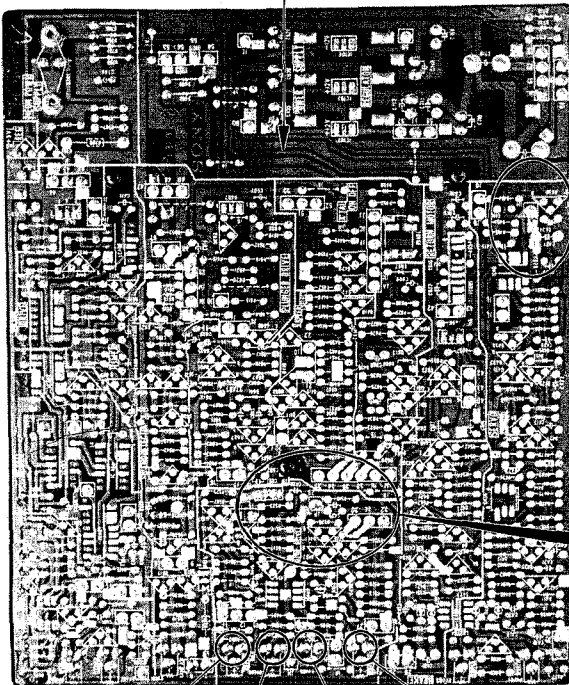

Fig. 13

servo amp board



RV407 offset RV406 RV405 gain RV408 offset

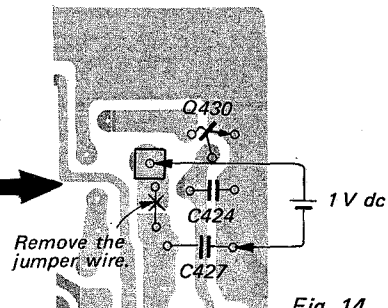

Fig. 14

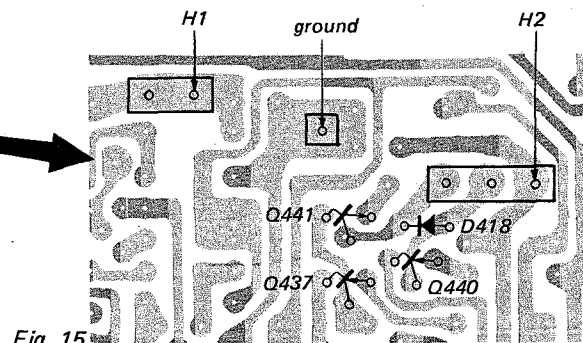
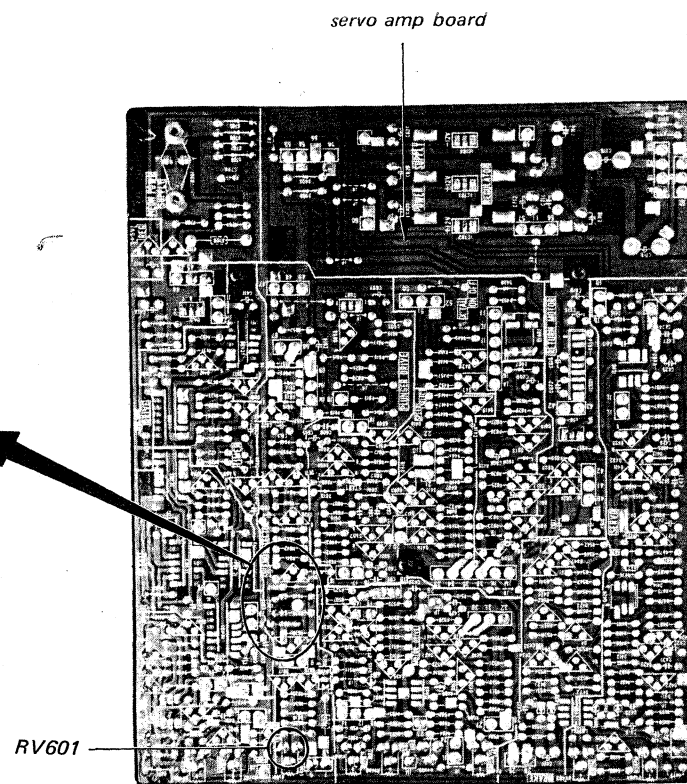
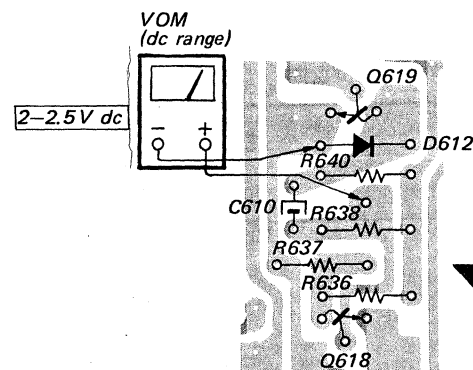
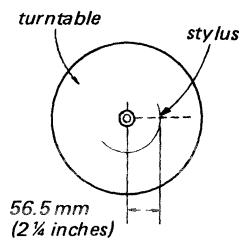
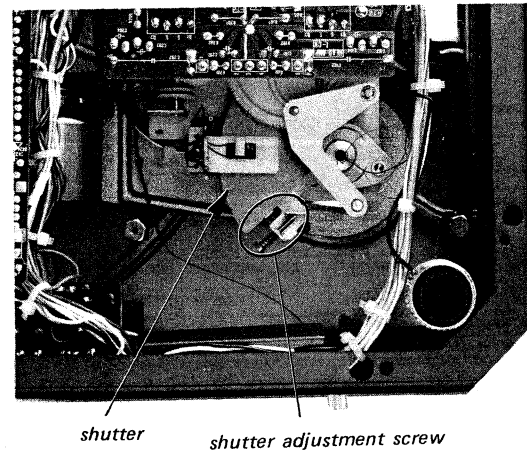

Fig. 15

AUTOMATIC RETURN POSITION ADJUSTMENT

1. Connect a VOM as shown below.
2. Bring the tonearm toward out-of lead groove of record to the full.
3. Adjust RV601 for 2–2.5V dc reading on the VOM.
4. When the stylus is set as shown below, adjust the shutter adjustment screw for 8 V dc reading on the VOM.
5. Play a test record (SONY YFSC-6, BAND 2) at 33 rpm. Confirm that the tonearm automatically returns within 15–17 counts. If not, adjust the shutter adjustment screw again.
6. Play a test record (SONY YFSC-6, BAND 3–6) at 33 rpm. Make sure that the tonearm returns only when 1 kHz signal sound is output from a speaker. If not, adjust RV601.
7. When RV601 is readjusted, repeat the steps 5 and 6.



OSCILLATOR FREQUENCY ADJUSTMENT

1. Connect a frequency counter to terminal ⑫ of IC402 on the servo amp board.
2. Set the speed switch to 45 rpm position.
3. Adjust RV402 for 192 Hz on the counter.
4. Set the speed switch to 33 rpm position.
5. Adjust RV401 for 142 Hz on the counter.

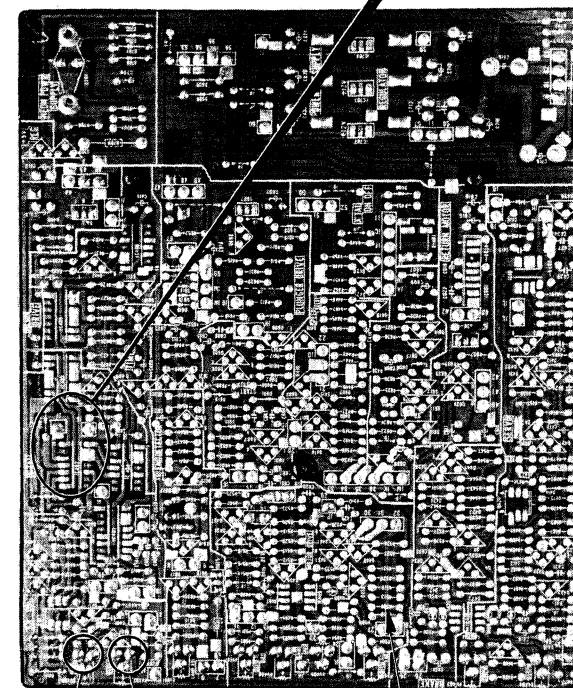
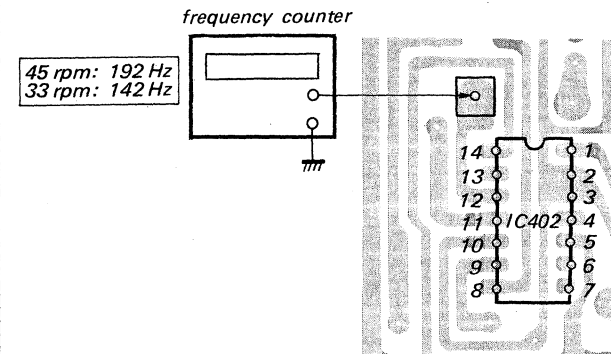

TURNTABLE SPEED ADJUSTMENT

1. Connect an oscilloscope to terminal ⑨ of IC401.
2. Set the crystal-lock switch to X'TAL-LOCK position.
3. Set the speed switch to 45 rpm position.
4. Adjust RV404 for waveform on the oscilloscope as shown below.
5. Set the speed switch to 33 rpm position.
6. Adjust RV403 for waveform on the oscilloscope as shown below.

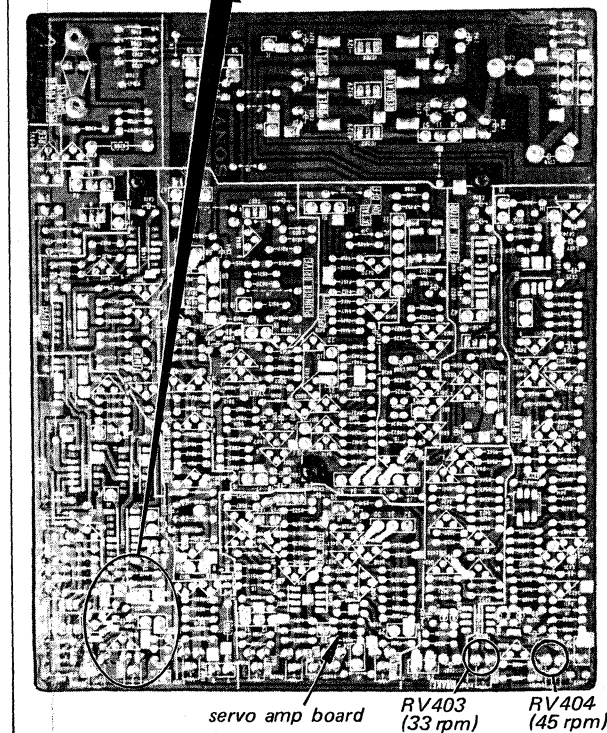
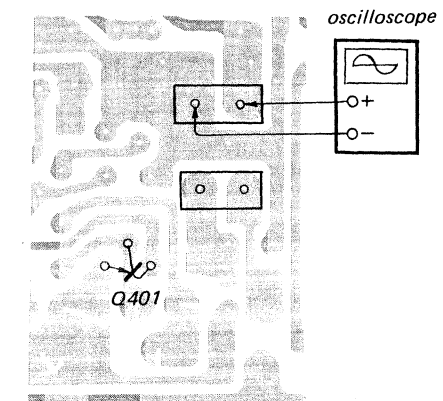
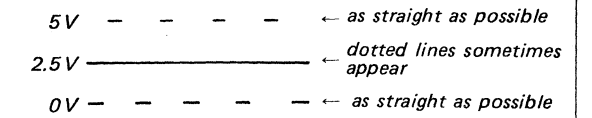

DC BALANCE ADJUSTMENT

1. Turn on the POWER switch.
2. Adjust RV101 (L-CH) and RV201 (R-CH) for 0V dc on the VOM with no signal input.

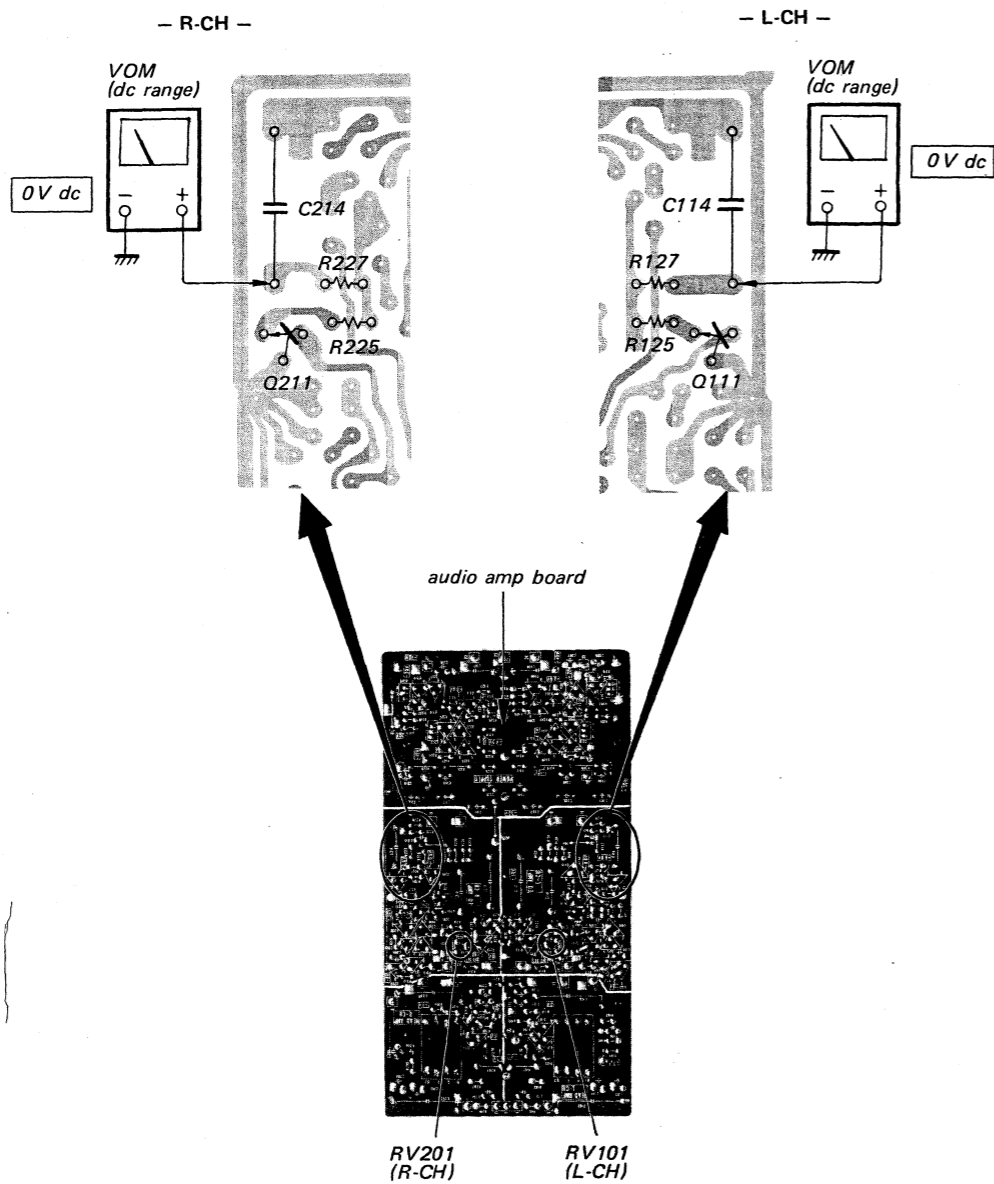

Replacement Semiconductors

For replacement, use semiconductors except in ().

Q402 Q407-412 Q414-424 Q429-432 Q442-448 Q601-606 Q609-614 Q616-624 Q626, 1502 Q434, 436 Q439, 441 Q608:	2SC1364	Q701: 2SC1431	Q702: 2SC926A	D409, 410 D415, 416 D419, 420 D604, 606	VD1221
Q435, 437 Q438, 440	2SA777	Q1503-1506: 2SC2023-R (2SC2023)		D401-404 D411-414 D417, 418 D421-424 D601-603 D611-616 D1501, 1502: D407, 605:	1S1555 (1T40) 1S1555 RD3.9E
Q607, 615 Q625 Q703, 704 Q706, 708	2SC1061 2SD476A	IC401: MSM5811		D405, 408 D608, 609 D704, 1001	10E2 (SIB01-02)
Q705, 707 Q709	2SB566A	IC402, 404 IC406 IC403, 405:	M53293P (SN7493AN) M53200P (SN7400N)	D406: D607: D610: D709, 711: D710: D712: D713:	EQB01-05 (EQA01-05R) EQB01-13 (EQA01-13R) EQB01-06 (EQA01-06R) EQB01-33 (EQA01-33R) EQB01-20 (EQA01-20R) EQB01-18 (EQA01-18R) EQB01-12Z (EQA01-12R)
Q401 Q404-406 Q425, 427 Q428, 433 Q1501	2SA893 (2SA678)	IC601: CX065A	IC701: μ PC78L05	D702, 703:	S2VB20
Q403, 426:	2SC1963	Q401		D705-708:	10E2 (GP08D)
Q413:	2SC2278 (2SC1127)	IC702, 703: μ PC14312H		D751-754:	U05G (U05E)
		IC704:	FS7912M	D755-757:	SLP24B
		D1503-1506:	S34	H1, 2:	5GF-MS-07F

SECTION 4
DIAGRAMS

4-1. MOUNTING DIAGRAM
(SYSTEM CONTROL SECTION)

— Conductor Side —

Replacement Semiconductors: See page 18.

Note:

- — : parts extracted from the component side.
- : B+ pattern
- ⊙ : B- pattern
- : Color code of sleeving over the end of the jacket.

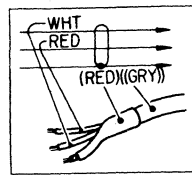

Q			1506		1502				IC704	IC70
IC			1505		1501					701
D	704			1503	1504	1506	754, 753			713 712
		702	1505	703	1501	752, 751		755	1001	705,706,707,708
										609 60:

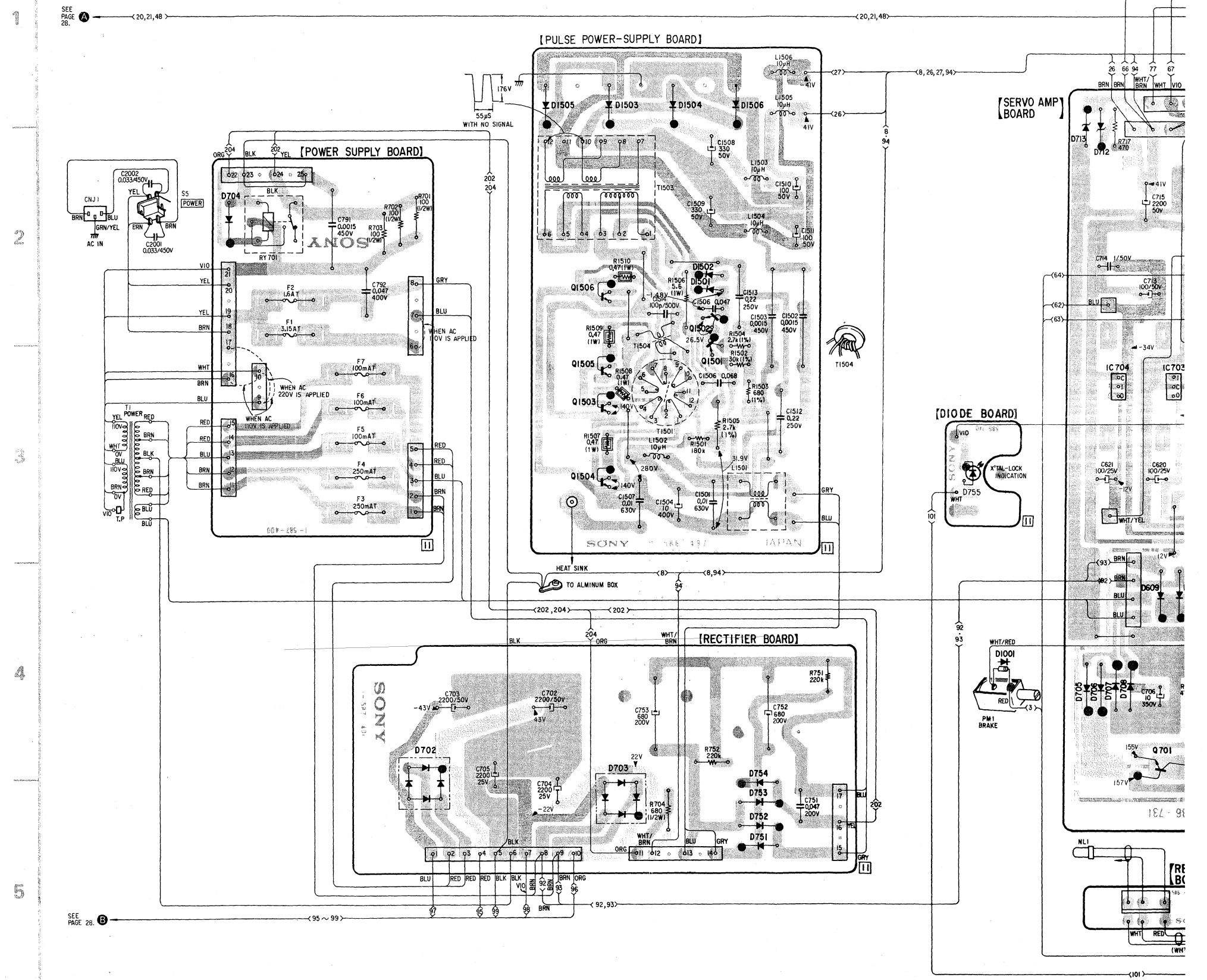

IC704	IC703	IC702	702	607	IC407	430	420	421	419	614,625	613	623	624,611	610	428	427	448	447	426	424	423	443,422	IC408	425
713	712	701	IC701	608	IC406	412	411	410	622	606	604	616	620,603	626	602	601	609	446	438	445	441,439,440	435	615, IC409	402
705,706,707,708	609	608		408	405	404	607	614,615,616	413	605	611	602	613,407	601	406	604	414	424	423	418	412	421	411	410,409
																								401

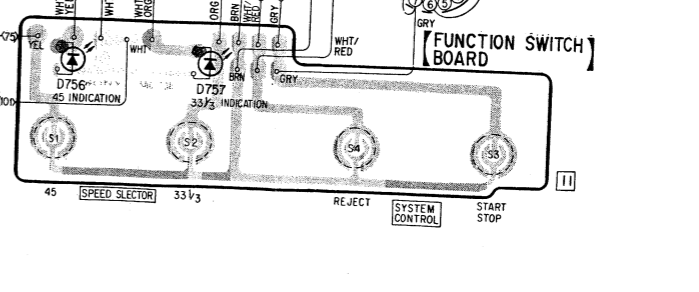
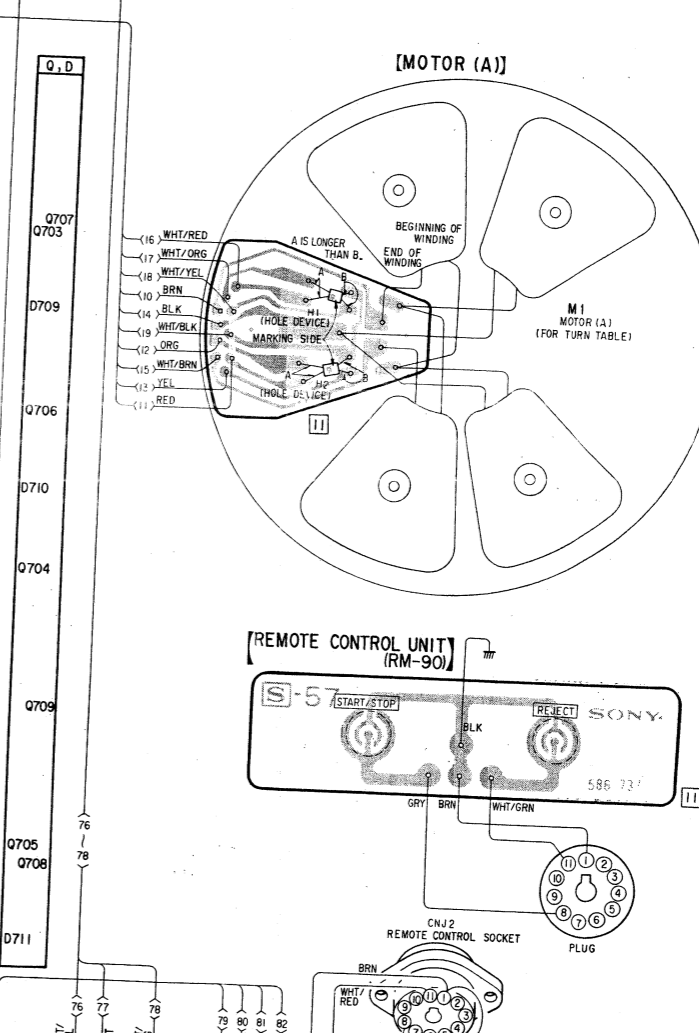
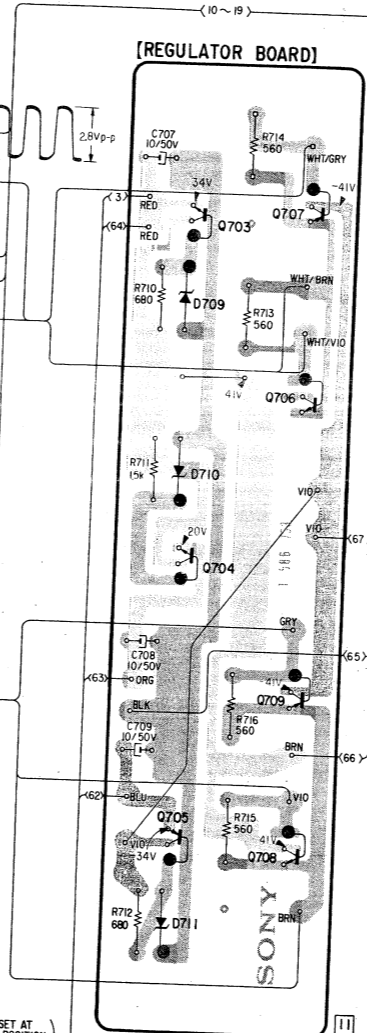
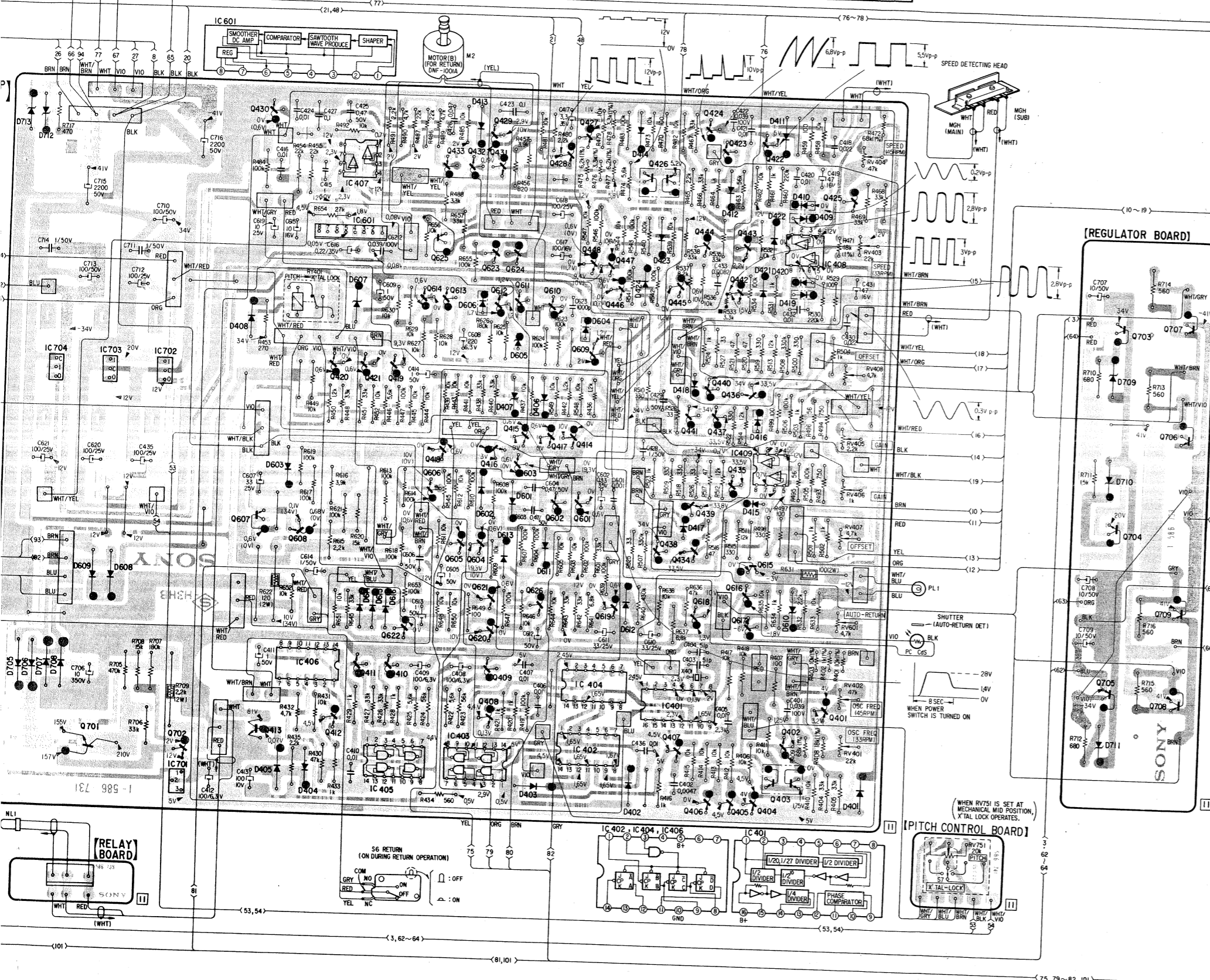

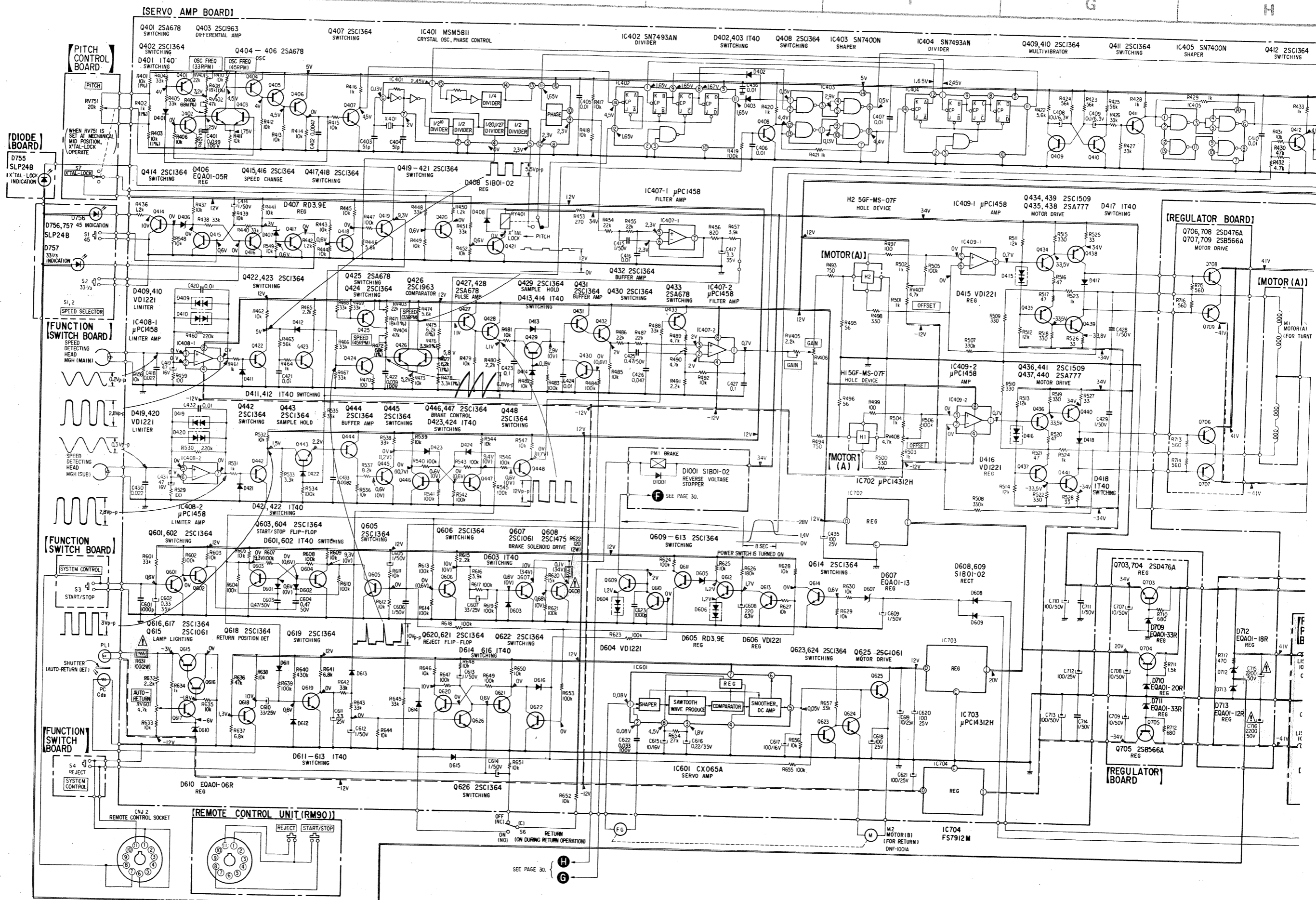

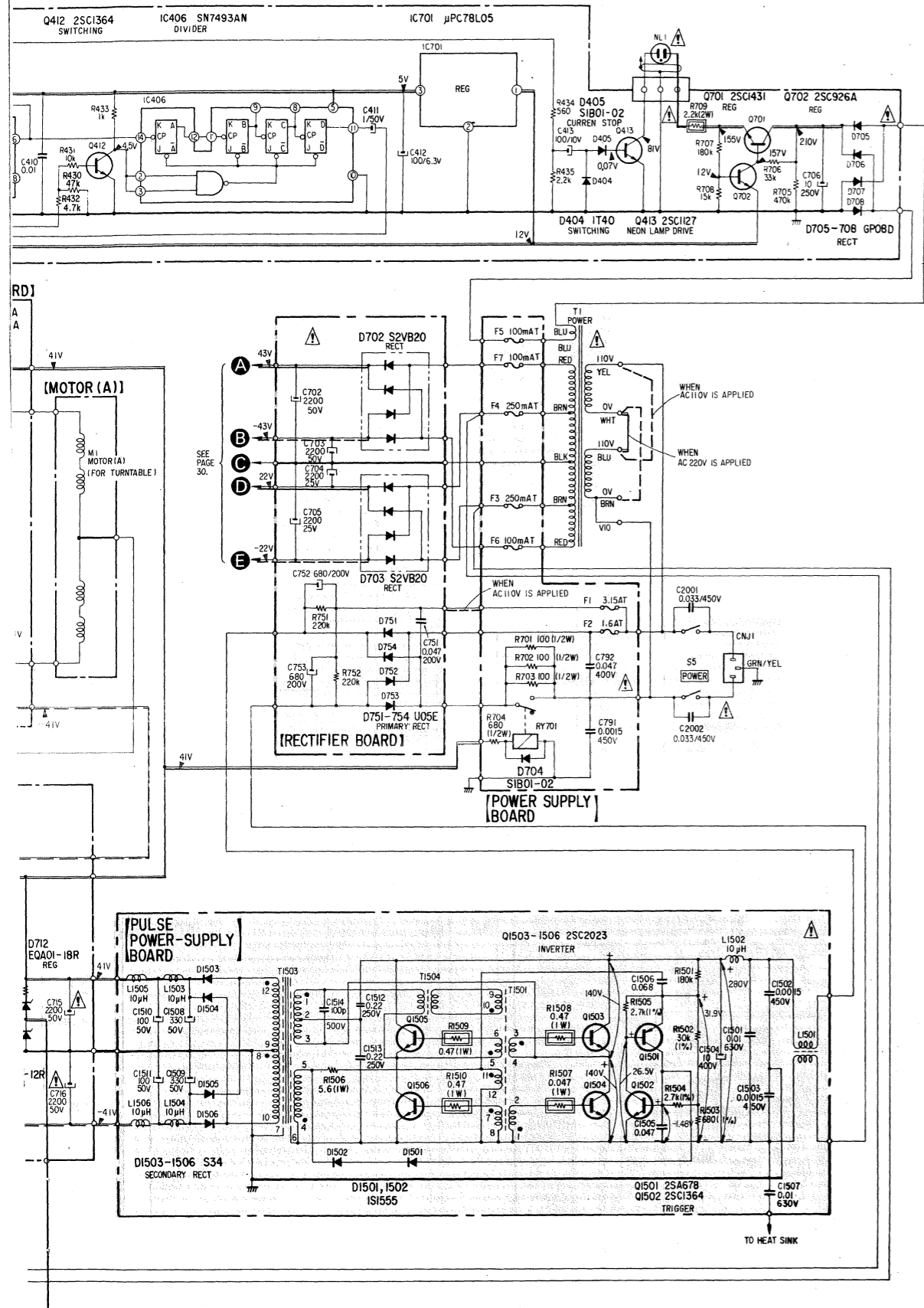

Note: The components identified by shading and mark are critical for safety. Replace only with part number specified.

- Note:**
- All capacitors are in μF unless otherwise noted. pF : μF 50VV or less are not indicated except for electrolytics and tantalum.
 - All resistors are in ohms, $\frac{1}{4}\text{W}$ unless otherwise noted.
 - $\text{k}\Omega$: 1000 Ω ; $\text{M}\Omega$: 1000 $\text{k}\Omega$
 - : nonflammable resistor.
 - : panel designation.
 - : adjustment for repair.
 - : B+ bus.
 - : B- bus.
 - Voltages are dc with respect to ground unless otherwise noted.
 - Readings are taken under no-signal conditions with a VOM (20 $\text{k}\Omega/\text{V}$).
 - () : stop
 - Voltage variations may be noted due to normal production tolerances.
 - (1%) indicates component tolerance.
 - All variable and adjustable resistors have characteristic curve B, unless otherwise noted.
 - Switch

Ref. No.	Switch	Position
S1	45 SPEED	OFF
S2	33 1/3 SELECTOR	OFF
S3	START/STOP SYSTEM	OFF
S4	REJECT CONTROL	OFF
S5	POWER	OFF
S6	RETURN	OFF
S7	X'TAL-LOCK	ON

Replacement Semiconductors

For replacement, use semiconductors except in ().

Q101, 201 Q104, 204 Q106, 206 Q109, 209 Q112, 212 Q113, 213 Q304, 306 Q309, 311 Q313, 314	: 2SC1775E (2SC1775)	
Q102, 202 Q111, 211	: 2SC1811	
Q103, 203 Q114, 214 Q303, 316 Q308, 321	: 2SK43-2 (2SK43) : 2SK43-5 (2SK43)	
Q105, 205 Q108, 208 Q110, 210 Q301, 302 Q315, 317 Q320, 322	: 2SA872E (2SA872)	
Q115, 215: 2SA896	Q107, 207: 2SK97	
Q305: 2SC1061 (2SC1061C) Q310: 2SC1173		
Q307, 312 Q319, 324	: 2SK30A	
Q318: 2SA671 Q323: 2SA473		
D101, 201 D102, 202	: VD1221 (VD1221M)	

4.3. MOUNTING DIAGRAM (AMP SECTION)

PS-X9 PS-X9

4.4. SCHEMATIC DIAGRAM (AMP SECTION)

- Conductor Side -

Replacement Semiconductors:
See page 26.

Note: For Mounting Diagram

- : parts extracted from the component side.
- : B+ pattern
- : B- pattern
- : signal path
- : L-CH signal path
- : R-CH signal path
- Color code of sleeving over the end of the jacket.

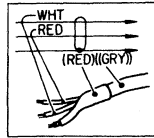

Note: For Schematic Diagram

- All capacitors are in μF unless otherwise noted. pF: μF 50WV or less are not indicated except for electrolytics and tantalum.
- All resistors are in ohms, $\frac{1}{2}W$ unless otherwise noted. k Ω : 1000 Ω ; M Ω : 1000 k Ω .
- : panel designation.
- : adjustment for repair.
- : B+ bus.
- - - : B- bus.
- Volts are dc with respect to ground unless otherwise noted.
- Readings are taken under no-signal conditions with a VOM (20 k Ω/V).
- Voltage variations may be noted due to normal production tolerances.
- 1% indicates component tolerance.
- All adjustable resistors have characteristic curve B, unless otherwise noted.
- Switch

Ref. No.	Switch	Position
S901-1 to 8	AMP SELECTOR	EQ
S902-1, 2	LOAD	100 pF
S903-1, 2	LOAD	25 k Ω

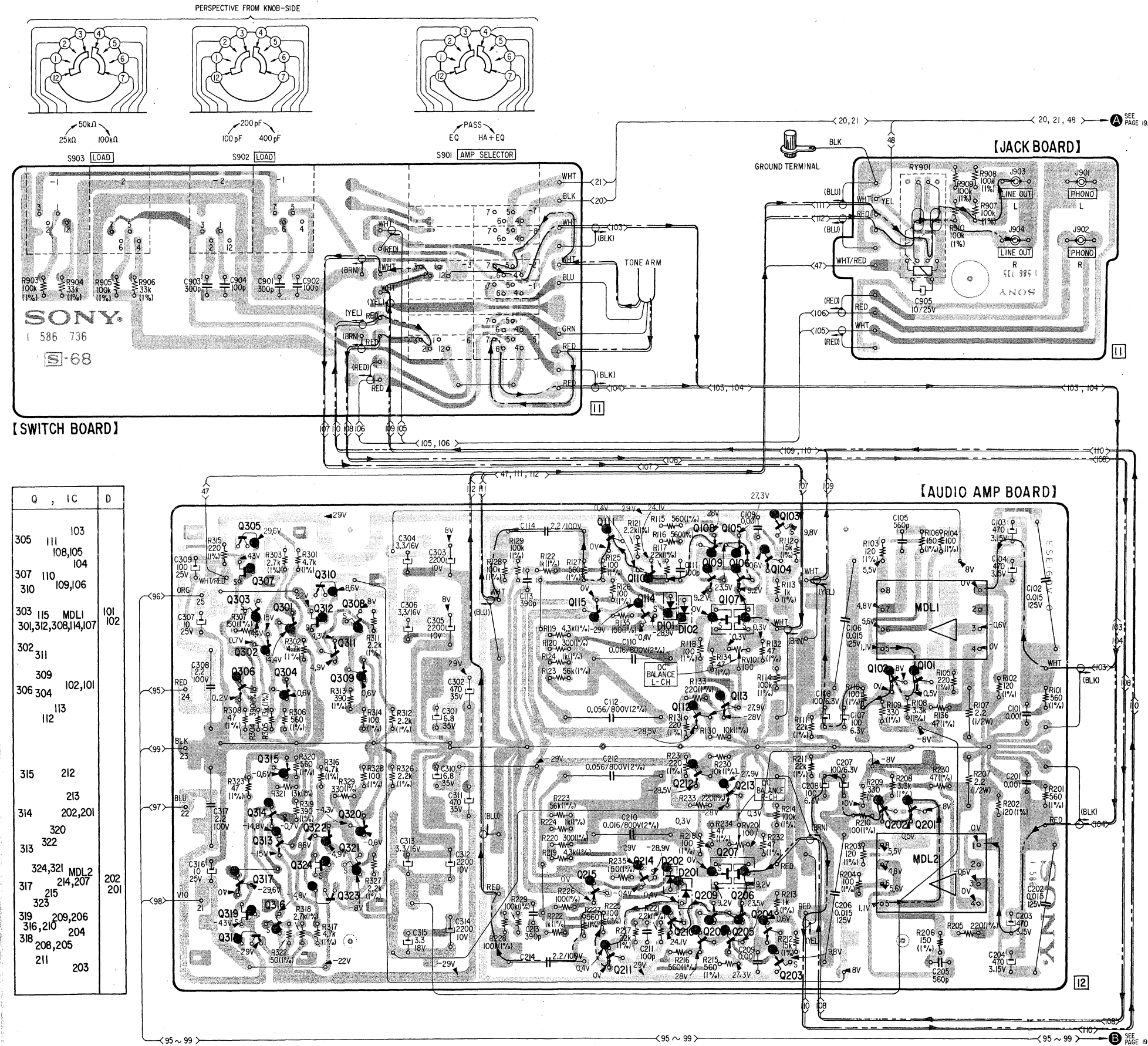

Q, IC	D
305 111 103	
	108,105
307 110 104	
310 109,106	
303 115 MDL1	101 102
301,312,308,114,107	
302 311	
309 102,101	
306 304	
113	
112	
315 212	
	213
314 202,201	
320	
313 322	
324,321 MDL2	202 201
317 214,207	
323 215	
319 209,206	
316,210 204	
318 208,205	
211 203	

[AUDIO AMP
L-CH

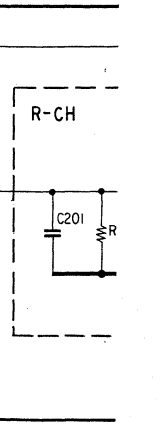
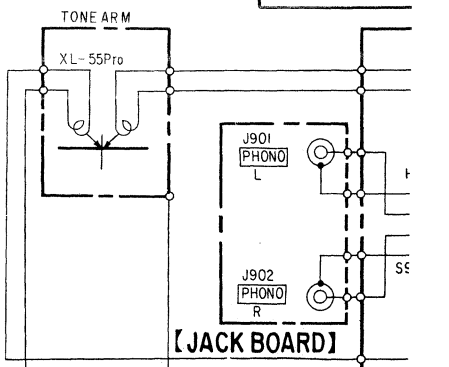
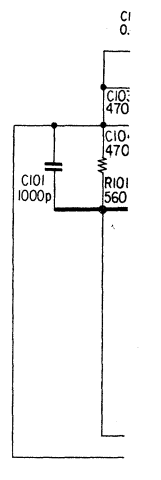

[AUDIO AMP BOARD]

L-CH

MDL1
AMP

HEAD AMP

Q101 2SC1775
BUFFER AMP
Q102 2SC1811

Q103 2SK43
CURRENT REG
Q104 2SC1775
REG
Q112,113 2SC1775
CURRENT MIRROR

Q105,108 2SA872
CURRENT MIRROR
Q106,109 2SC1775
CASCODE AMP
Q107 2SK97
EQ PREAMP

Q110 2SA872
EQ 2nd AMP
Q114 2SK43
CURRENT REG
D101,102 VD1221M
REG

Q111 2SC1811
EQ AMP OUT
Q115 2SA896

Q301,302 2SA872
DIFFERENTIAL AMP

Q303 2SK43
CURRENT REG

Q305 2SC1061C
REG
Q306 2SC1775
DET-AMP

Q307 2SK30A
CURRENT REG
Q308 2SK43
CURRENT REG
Q309 2SC1775
REG

Q310 2SC1173
REG
Q312 2SK30A
CURRENT REG
Q311 2SC1775
DET-AMP

VOLTAGE REGULATOR

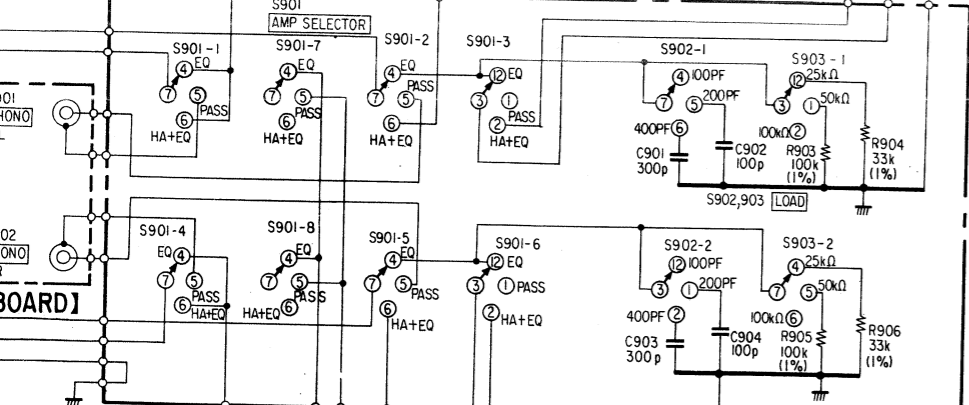
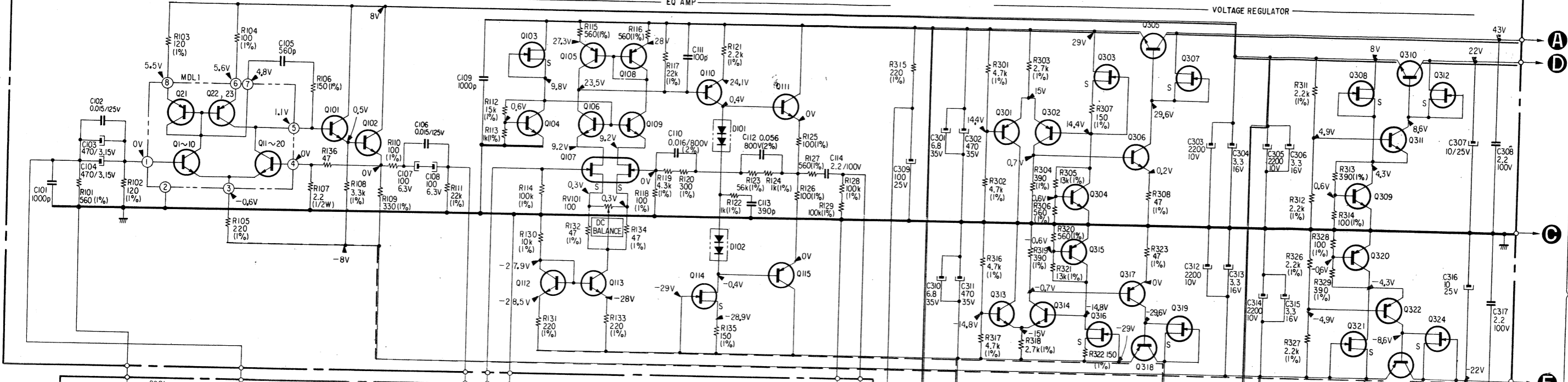

[JACK BOARD]

Q313,314 2SC1775
DIFFERENTIAL AMP
Q315 2SA872
REG
Q316 2SK43
CURRENT REG
Q317 2SA872
DET-AMP
Q318 2SA671
REG
Q319 2SK30A
CURRENT REG

VOLTAGE REGULATOR

Q320 2SA872
REG
Q321 2SK43
CURRENT REG
Q322 2SA872
DET-AMP
Q323 2SA473
REG
Q324 2SK30A
CURRENT REG

R-CH

R-CH
(SAME AS L-CH.
REF NO. FROM 201)

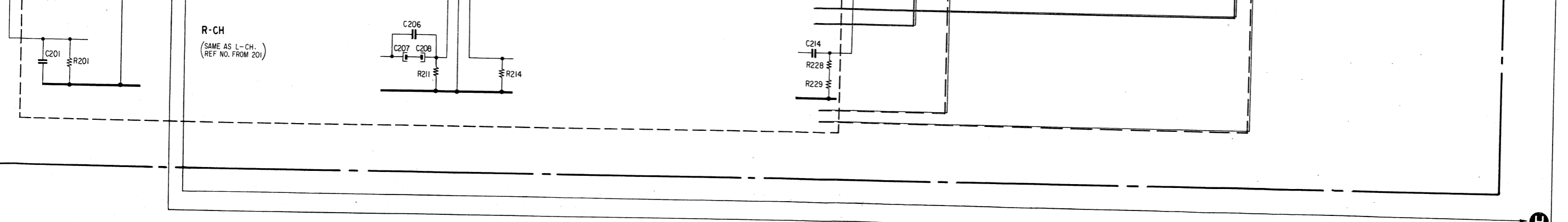

SEE PAGE 23-25

SECTION 5 EXPLODED VIEWS

A

B

C

D

- 5-1. Note:**
- Items with no part number and/or no description are not stocked because they are seldom required for routine service.
 - All screws are Phillips (cross recess) type unless otherwise noted.
 - (-) = slotted head
 - Circled letters (A) to (Z) are applicable to European models only.

Note: The components identified by shading and mark are critical for safety. Replace only with part number specified.

1

2

3

4

5

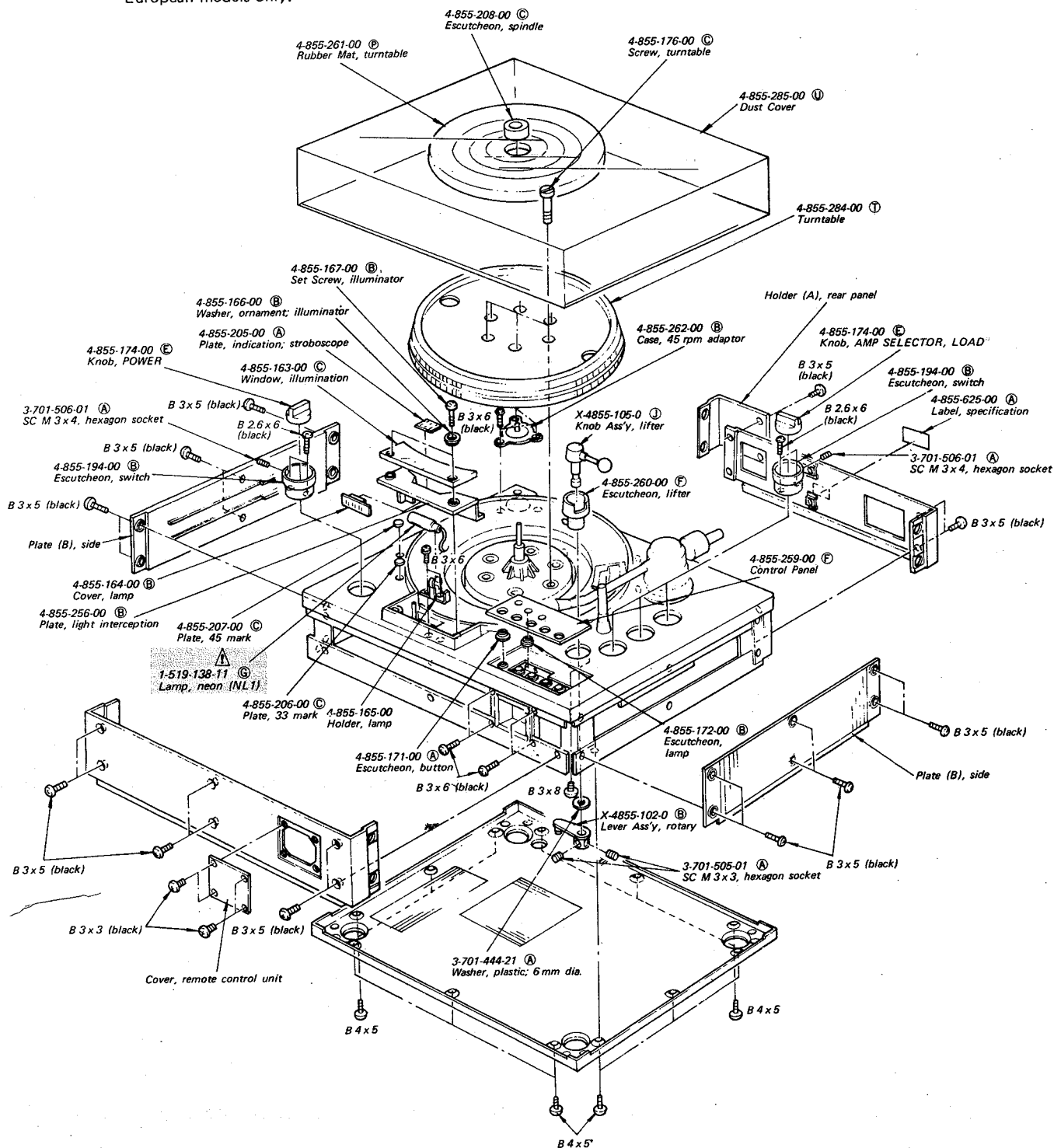

A

B

C

D

- 5-2. Note:
- Items with no part number and/or no description are not stocked because they are seldom required for routine service.
 - All screws are Phillips (cross recess) type unless otherwise noted.
(-) = slotted head
 - Circled letters (A) to (Z) are applicable to European models only.

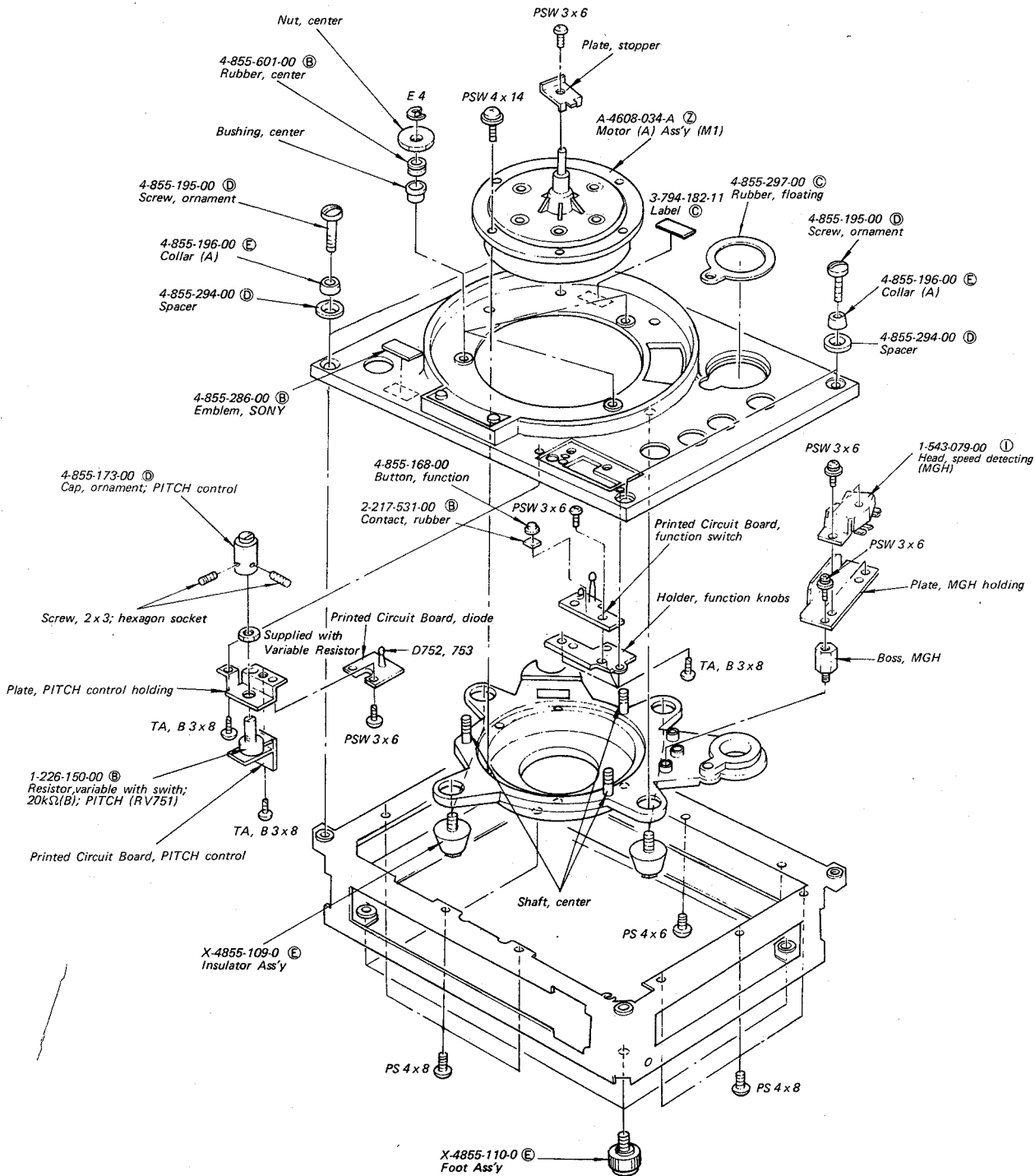

E

D

C

B

A

5-3.

1

2

3

4

Note: The components identified by shading and mark Δ are critical for safety. Replace only with part number specified.

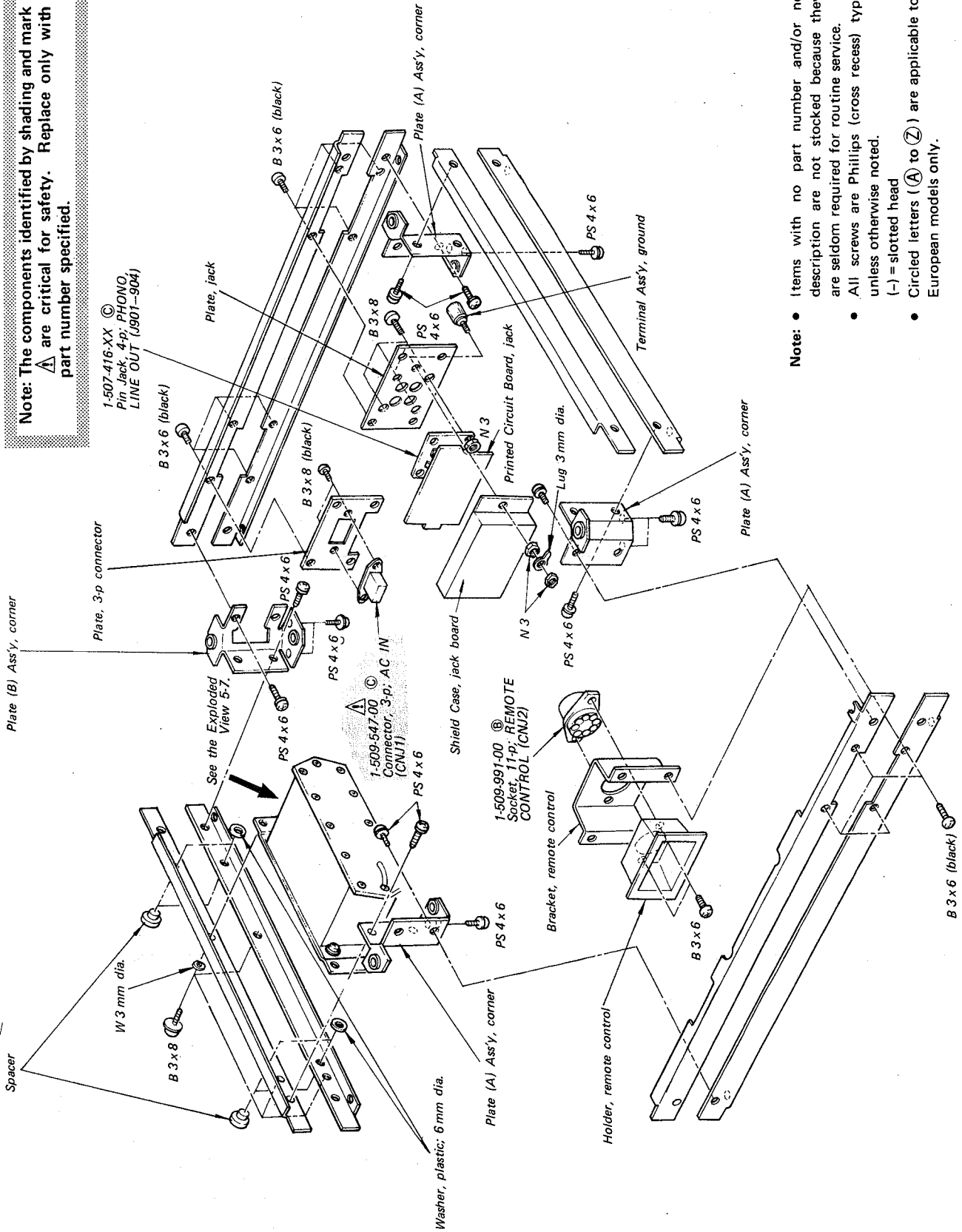

- Note:
- Items with no part number and/or no description are not stocked because they are seldom required for routine service.
 - All screws are Phillips (cross recess) type unless otherwise noted.
 - Circled letters (A to Z) are applicable to European models only.

A B C D

- 5-4. Note:
- Items with no part number and/or no description are not stocked because they are seldom required for routine service.
 - All screws are Phillips (cross recess) type unless otherwise noted.
 - (-) = slotted head
 - Circled letters (A to Z) are applicable to European models only.

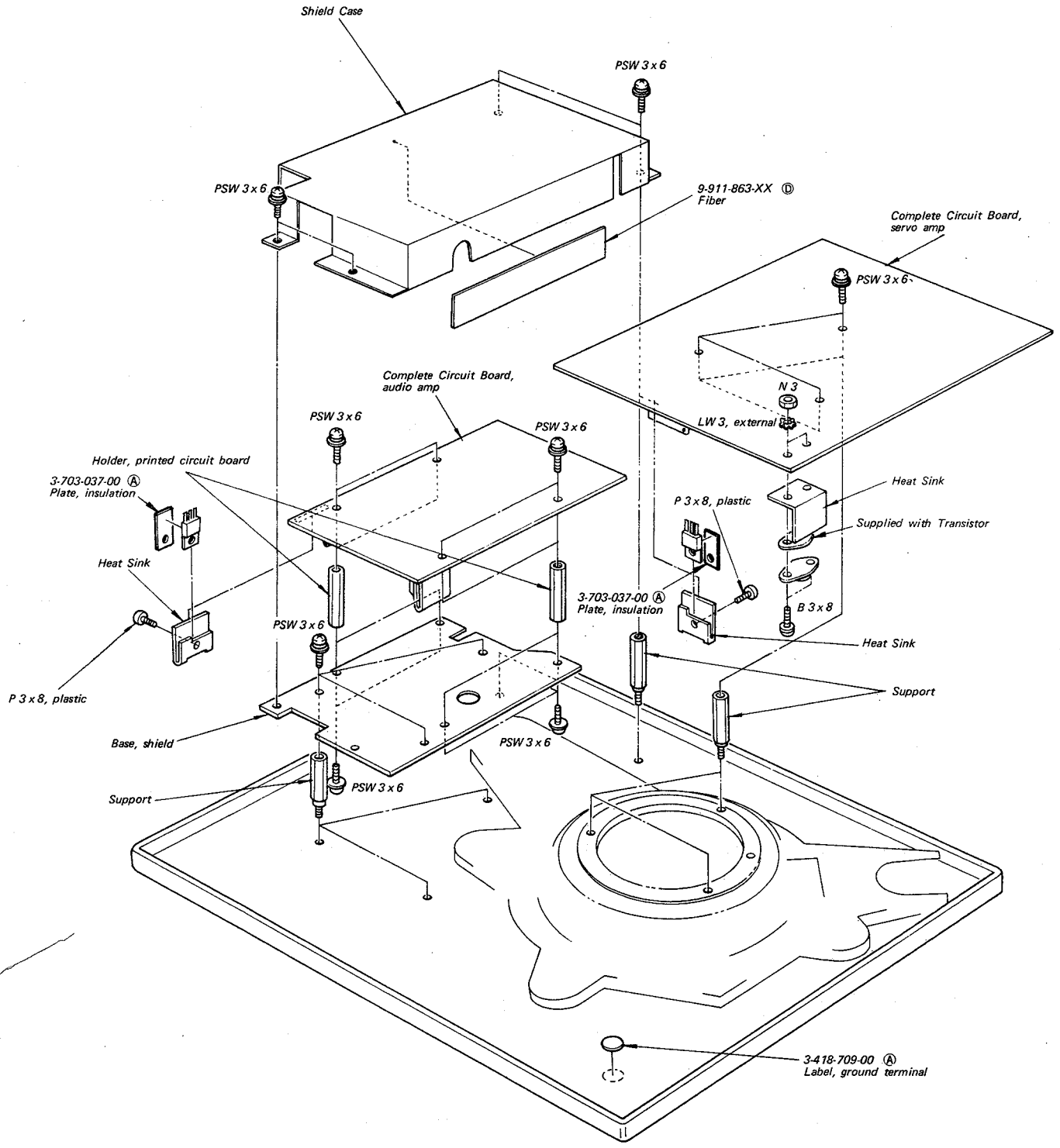

A

B

C

D

5-5.

- Note:**
- Items with no part number and/or no description are not stocked because they are seldom required for routine service.
 - All screws are Phillips (cross recess) type unless otherwise noted.
 - (-) = slotted head
 - Circled letters (A) to (Z) are applicable to European models only.

Note: The components identified by shading and mark  are critical for safety. Replace only with part number specified.

1

2

3

4

5

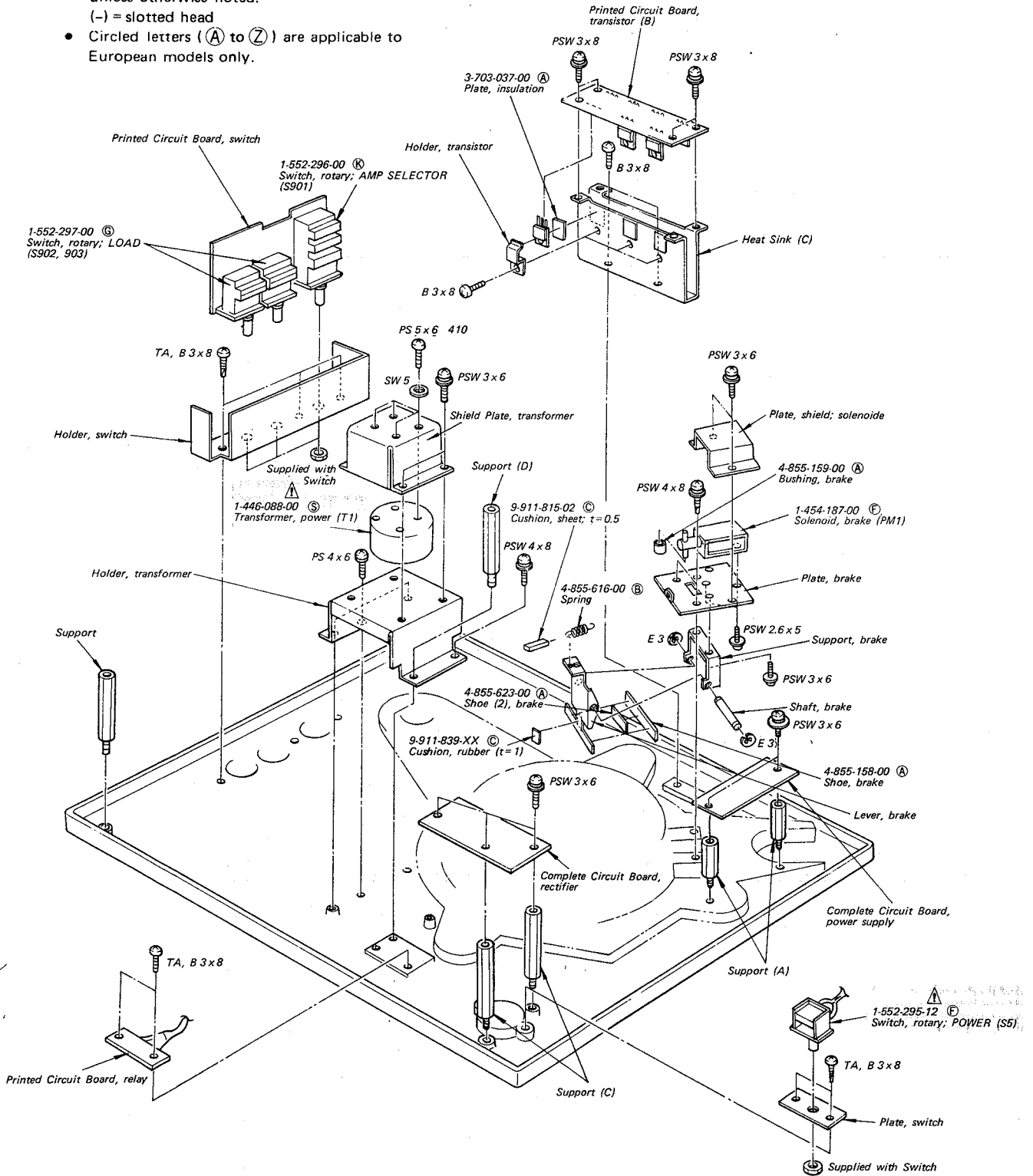

A B C D

- 5-6. Note:
- Items with no part number and/or no description are not stocked because they are seldom required for routine service.
 - All screws are Phillips (cross recess) type unless otherwise noted.
 - (-) = slotted head
 - (□□T) shows the number of coils in spring.
 - Circled letters (A to Z) are applicable to European models only.

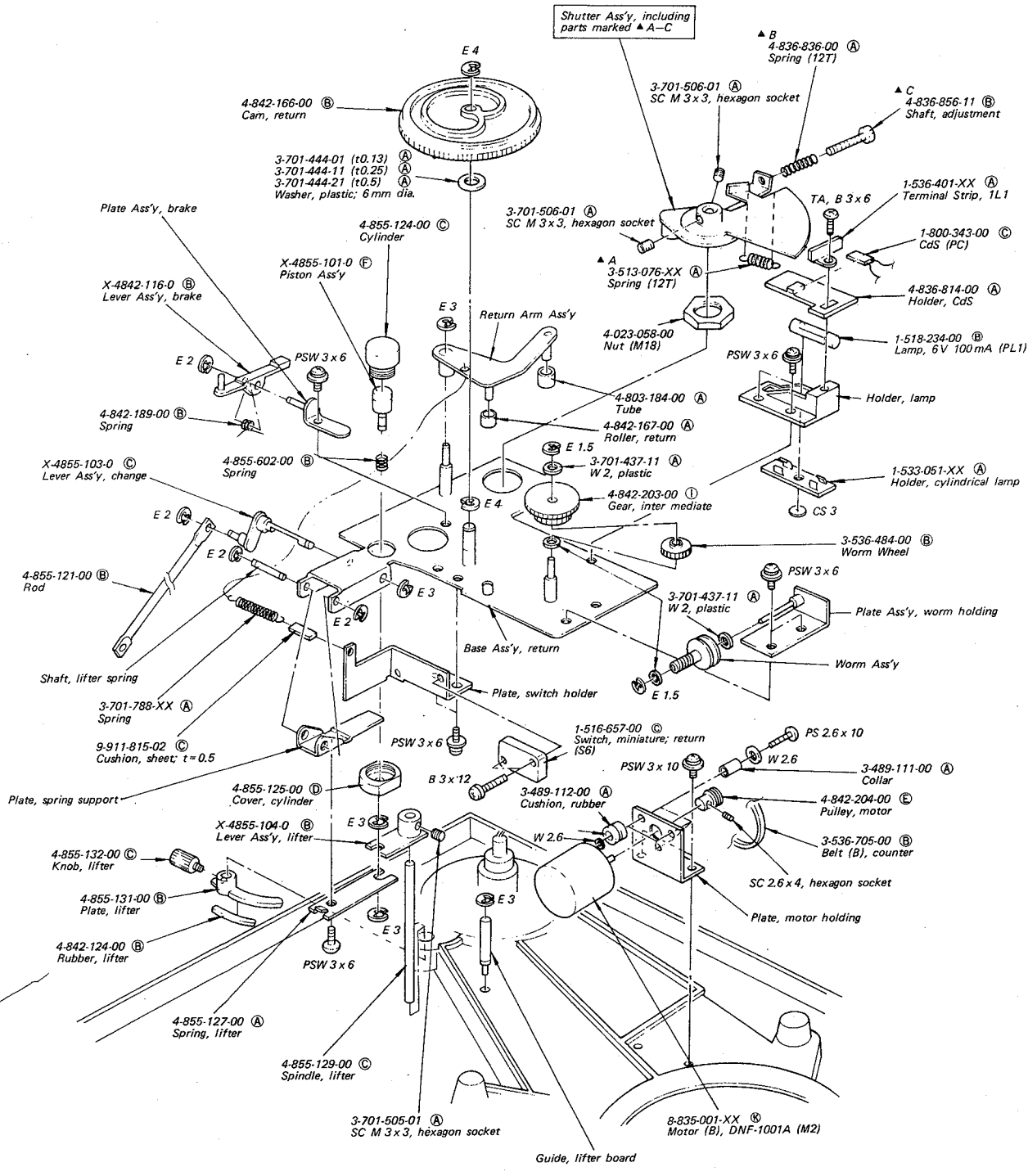

A

B

C

D

5-7.

- Note:**
- Items with no part number and/or no description are not stocked because they are seldom required for routine service.
 - All screws are Phillips (cross recess) type unless otherwise noted.
(-) = slotted head
 - Les lettres entourées (A à Z) ne sont applicables qu'aux modèles européens.

1

2

3

4

5

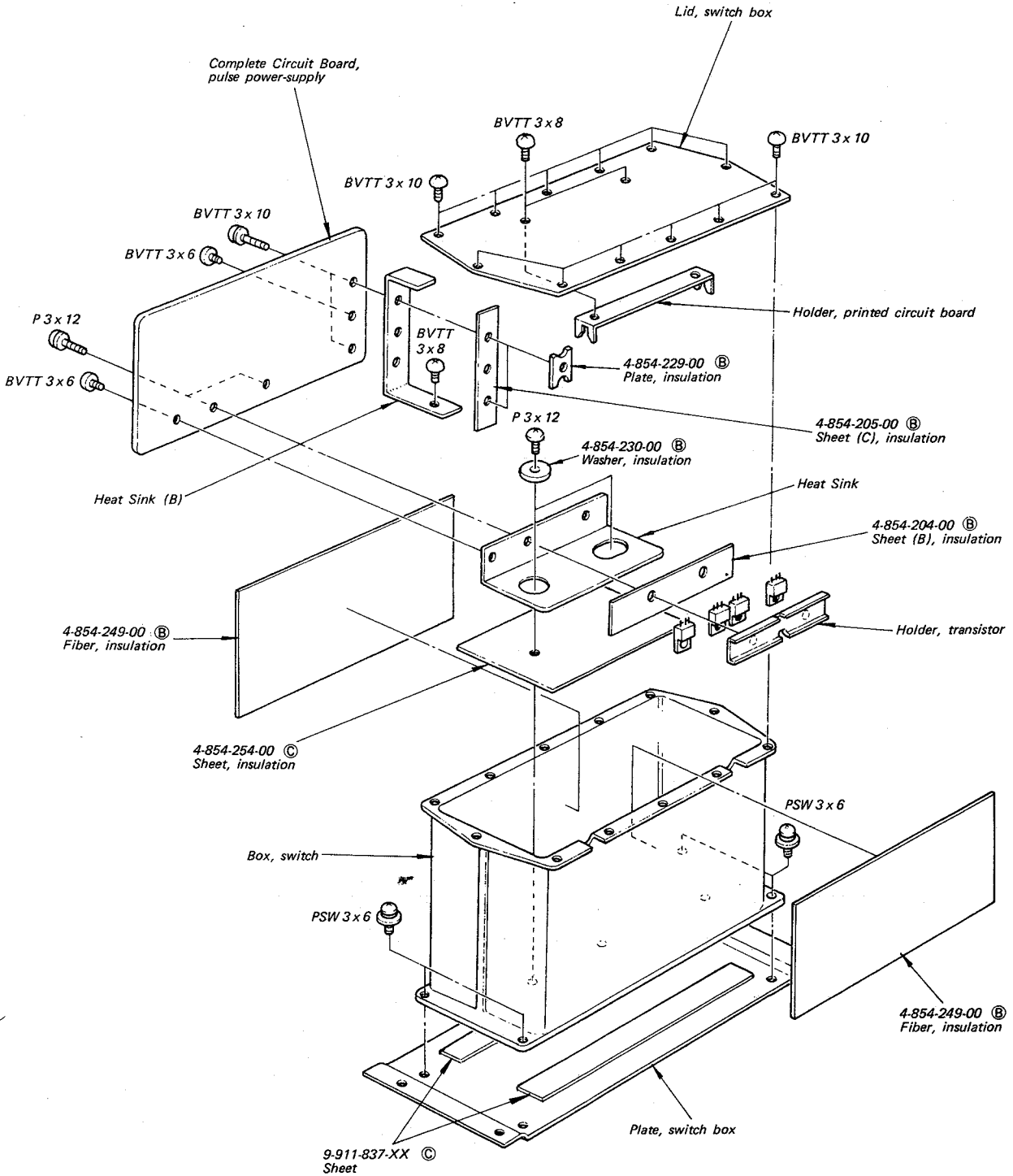

A B C D

- 5-8. Note:
- Items with no part number and/or no description are not stocked because they are seldom required for routine service.
 - All screws are Phillips (cross recess) type unless otherwise noted.
 - (-) = slotted head
 - Les lettres entourées (A à Z) ne sont applicables qu'aux modèles européens.

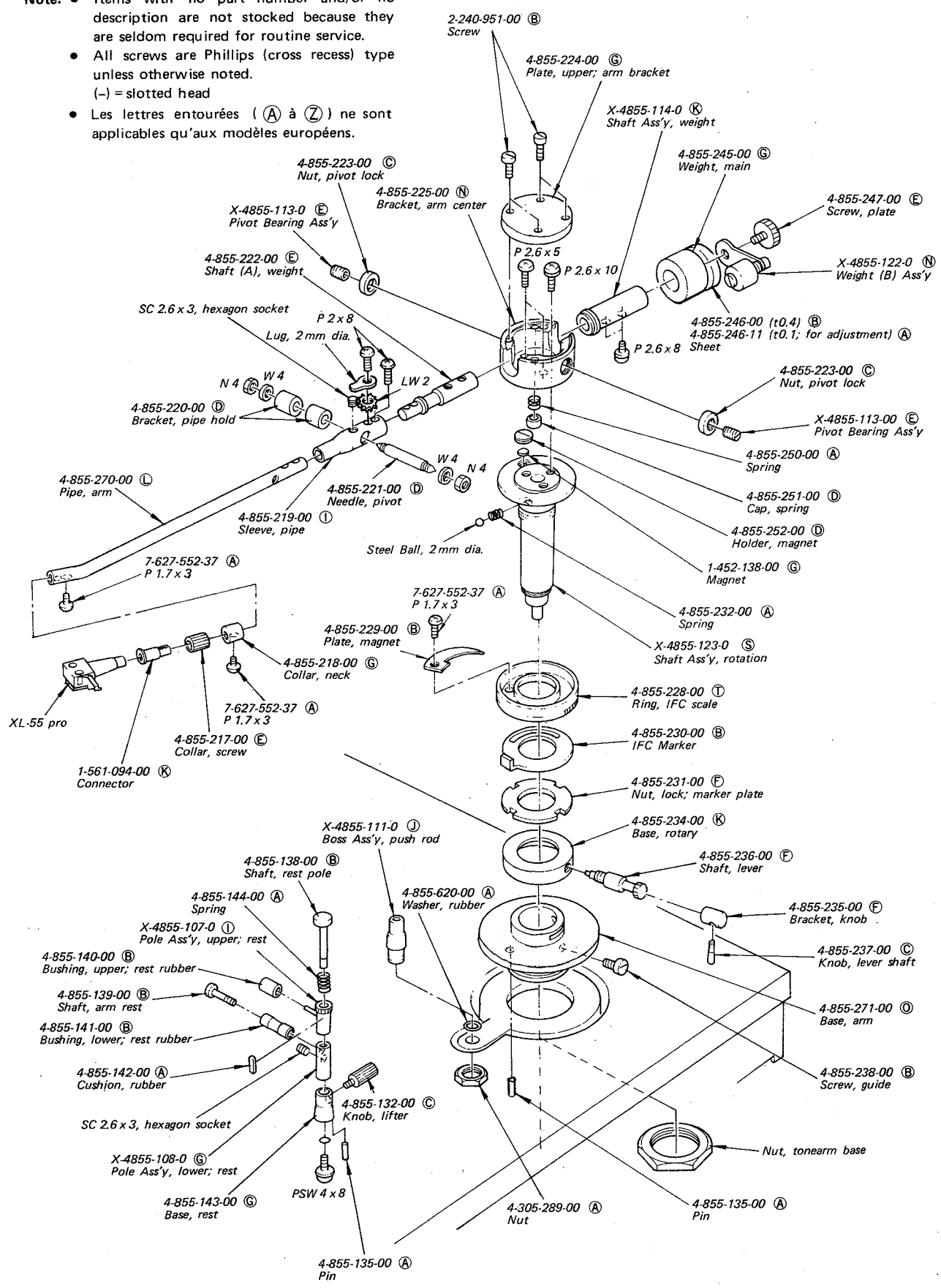

SECTION 6
ELECTRICAL PARTS LIST

Note: Circled letters (A to Z) are applicable to European models only.

5-9. Note: • Items with no part number and/or no description are not stocked because they are seldom required for routine service.
• All screws are Phillips (cross recess) type unless otherwise noted.
(-) = slotted head
• Circled letters (A to Z) are applicable to European models only.

1
2
3
4
5

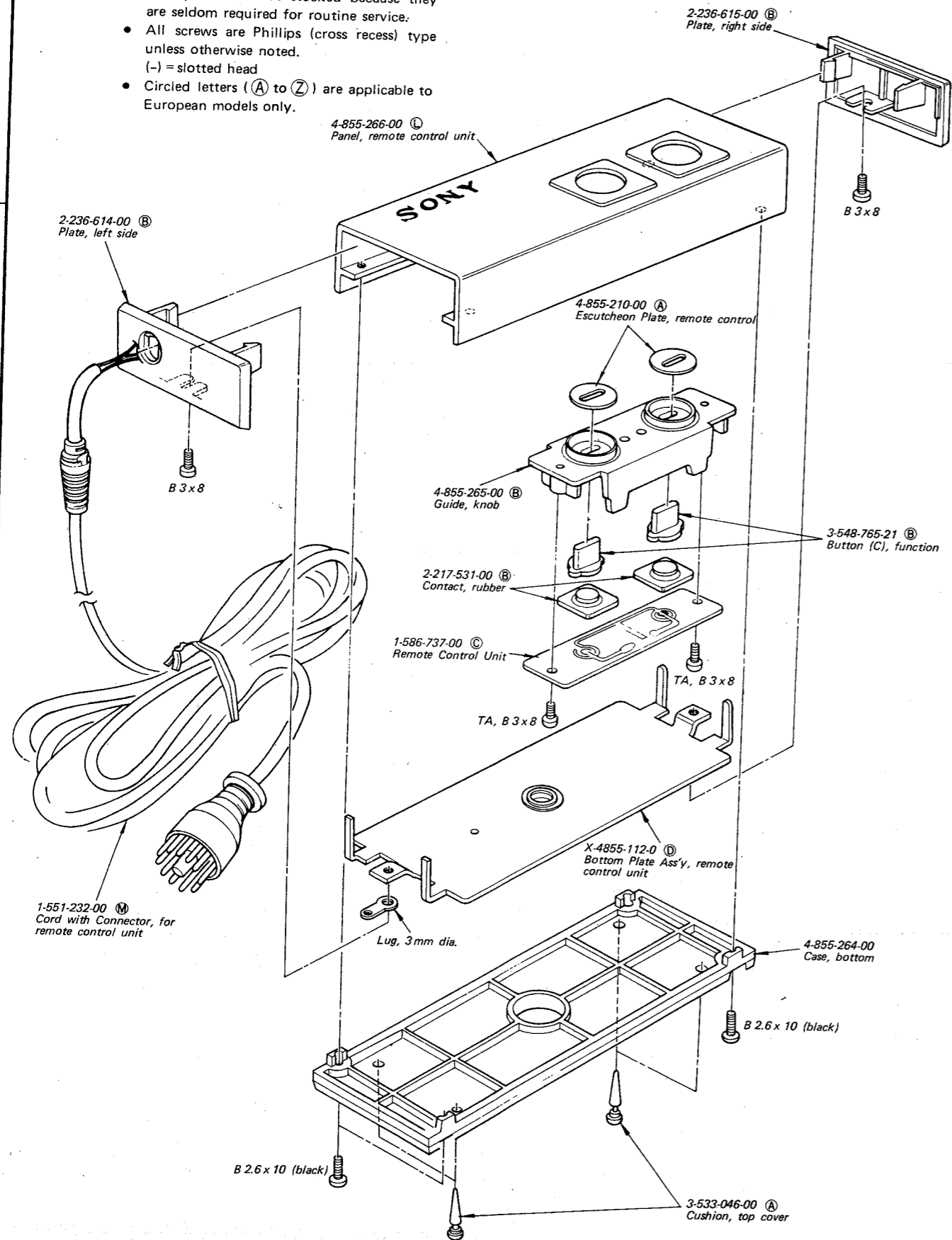

Ref. No.	Part No.	Description
SEMICONDUCTORS		
Transistors		
⇒ Q101,201	8-729-377-58 (B)	2SC1775E
Q102,202	8-765-012-20 (B)	2SC1811
⇒ Q103,203	8-723-302-00 (D)	2SK43-2
⇒ Q104,204	8-729-377-58 (B)	2SC1775E
⇒ Q105,205	8-729-387-28 (B)	2SA872E
⇒ Q106,206	8-729-377-58 (B)	2SC1775E
Q107,207	8-765-342-10 (F)	2SK97
⇒ Q108,208	8-729-387-28 (B)	2SA872E
⇒ Q109,209	8-729-377-58 (B)	2SC1775E
⇒ Q110,210	8-729-387-28 (B)	2SA872E
Q111,211	8-765-012-20 (C)	2SC1811
⇒ Q112,212	8-729-377-58 (B)	2SC1775E
⇒ Q113,213	8-729-377-58 (B)	2SC1775E
⇒ Q114,214	8-723-302-00 (D)	2SK43-2
Q115,215	8-765-082-20 (C)	2SA896
⇒ Q301,302	8-729-387-28 (B)	2SA872E
⇒ Q303	8-723-302-00 (D)	2SK43-2
⇒ Q304	8-729-377-58 (B)	2SC1775E
⇒ Q305	8-729-316-12 (D)	2SC1061
⇒ Q306	8-729-377-58 (B)	2SC1775E
Q307	8-729-203-04 (B)	2SK30A
⇒ Q308	8-723-305-00 (B)	2SK43-5
⇒ Q309	8-729-377-58 (B)	2SC1775E
Q310	8-729-217-33 (D)	2SC1173
⇒ Q311	8-729-377-58 (C)	2SC1775E
Q312	8-729-203-04 (B)	2SK30A
⇒ Q313,314	8-729-377-58 (D)	2SC1775E
⇒ Q315	8-729-387-28 (B)	2SC872E
⇒ Q316	8-723-302-00 (D)	2SK43-2
⇒ Q317	8-729-387-28 (B)	2SA872E
Q318	8-729-317-12 (E)	2SA671
Q319	8-729-203-04 (B)	2SK30A
⇒ Q320	8-729-387-28 (B)	2SA872E
⇒ Q321	8-723-305-00 (B)	2SK43-5
⇒ Q322	8-729-387-28 (B)	2SA872E
Q323	8-729-247-33 (C)	2SA473

Ref. No.	Part No.	Description
Q324	8-729-203-04 (B)	2SK30A
⇒ Q401	8-729-389-37 (B)	2SA893
Q402	8-729-633-47 (D)	2SC1364
Q403	8-765-222-20 (D)	2SC1963
⇒ Q404-406	8-729-389-37 (B)	2SA893
Q407-412	8-729-633-47 (D)	2SC1364
⇒ Q413	8-729-322-78 (C)	2SC2278
Q414-424	8-729-663-47 (D)	2SC1364
⇒ Q425	8-729-389-37 (B)	2SA893
Q426	8-765-222-20 (D)	2SC1963
⇒ Q427,428	8-729-389-37 (B)	2SA893
Q429-432	8-729-663-47 (D)	2SC1364
⇒ Q433	8-729-389-37 (B)	2SA893
Q434	8-729-450-93 (B)	2SC1509
Q435	8-729-477-73 (C)	2SA777
Q436	8-729-450-93 (B)	2SC1509
Q437,438	8-729-477-73 (C)	2SA777
Q439	8-729-450-93 (B)	2SC1509
Q440	8-729-477-73 (C)	2SA777
Q441	8-729-450-93 (B)	2SC1509
Q442-448	8-729-663-47 (B)	2SC1364
Q601-606	8-729-663-47 (B)	2SC1364
Q607	8-729-316-12 (D)	2SC1061
Q608	8-760-413-10 (C)	2SC1475
Q609-614	8-729-663-47 (D)	2SC1364
Q615	8-729-316-12 (D)	2SC1061
Q616-624	8-729-663-47 (B)	2SC1364
Q625	8-729-316-12 (D)	2SC1061
Q626	8-729-663-47 (B)	2SC1364
Q701	8-760-122-01 (E)	2SC1431
Q702	8-720-950-03 (C)	2SC926A
Q703,704	8-729-307-62 (D)	2SD476A
Q705	8-729-306-62 (E)	2SB566A
Q706	8-729-307-62 (D)	2SD476A
Q707	8-729-306-62 (E)	2SB566A
Q708	8-729-307-62 (D)	2SD476A
Q709	8-729-306-62 (E)	2SB566A

⇒ Due to standardization, interchangeable replacements may be substituted for parts specified in the diagrams.

Note: Circled letters (A to Z) are applicable to European models only.

Ref. No.	Part No.	Description
⇒ Q1501	△8-729-389-37	ⓑ 2SA893
Q1502	△8-729-633-47	ⓓ 2SC1364
⇒ Q1503		
1	△8-729-302-31	ⓔ 2SC2023-R
⇒ Q1506		
H1,2	8-719-905-07	ⓓ 5GF-MS-07F
Diodes		
⇒ D101,201	8-719-122-10	Ⓐ VD1221
⇒ D102,202		
⇒ D401-404	8-719-815-55	ⓑ IS1555
⇒ D405	8-719-200-02	ⓑ 10E2
⇒ D406	8-719-931-05	ⓑ EQB01-05
D407	8-719-139-07	ⓑ RD3.9E
⇒ D408	8-719-200-02	ⓑ 10E2
D409,410	8-719-122-10	Ⓐ VD1221
⇒ D411-414	8-719-815-55	ⓑ IS1555
D415,416	8-719-122-10	Ⓐ VD1221
⇒ D417,418	8-729-815-55	ⓑ IS1555
D419,420	8-719-122-10	Ⓐ VD1221
⇒ D421-424	8-719-815-55	ⓑ IS1555
⇒ D601-603	8-719-815-55	ⓑ IS1555
D604	8-719-122-10	Ⓐ VD1221
D605	8-719-139-07	ⓑ RD3.9E
D606	8-719-122-10	Ⓐ VD1221
⇒ D607	8-719-931-13	ⓑ EQB01-13
⇒ D608,609	8-719-200-02	ⓑ 10E2
⇒ D610	8-719-931-06	ⓑ EQB01-06
⇒ D611-616	8-719-815-55	ⓑ IS1555
D702,703	△8-719-502-20	ⓐ S2VB20
⇒ D704	8-719-200-02	ⓑ 10E2
⇒ D705-708	△8-719-200-02	ⓑ 10E2
⇒ D709	8-719-931-33	ⓑ EQB01-33
⇒ D710	8-719-931-20	ⓑ EQB01-20
⇒ D711	8-719-931-33	ⓑ EQB01-33
⇒ D712	8-719-931-18	ⓑ EQB01-18
⇒ D713	8-719-930-12	ⓑ EQB01-12Z
⇒ D751-754	△8-719-911-55	ⓑ U05G
D755-757	8-719-900-24	ⓐ SLP24B
⇒ D1001	8-719-200-02	ⓑ 10E2

D1501	△8-719-815-55	ⓑ IS1555
D1502		

⇒: Due to standardization, interchangeable replacements may be substituted for parts specified in the diagrams.

Ref. No.	Part No.	Description
D1503		
1	△8-719-303-41	ⓐ S34
D1506		
ICs		
IC401	8-759-958-11	ⓐ MSM5811
⇒ IC402	8-759-632-93	ⓐ M53293P
⇒ IC403	8-759-632-00	ⓔ M53200P
⇒ IC404	8-759-632-93	ⓐ M53293P
⇒ IC405	8-759-632-00	ⓔ M53200P
⇒ IC406	8-759-632-93	ⓐ M53293P
⇒ IC407-409	8-759-114-58	ⓔ μPC1458C
IC601	8-759-600-65	ⓐ CX065A
IC701	8-759-178-05	ⓐ μPC78L05
IC702,703	8-759-143-12	ⓐ μPC14312H
IC704	8-759-379-12	ⓐ FS7912M
COILS		
L1501	△1-421-340-00	ⓔ Choke, line filter
L1502		
1	△1-421-329-00	ⓑ Choke, 10μH
L1506		
TRANSFORMERS AND FILTER		
T1	△1-446-088-00	ⓐ Power
T1501	△1-433-197-11	ⓐ OSC
T1503	△1-446-087-00	ⓐ Converter
T1504	△1-543-129-00	ⓐ Core
CAPACITORS		
All capacitors are in μF and ceramic unless otherwise noted. 50WV or less are not indicated except for electrolytics. p: μF, elect=electrolytic		
C101,201	1-102-074-00	Ⓐ 1000p
C102,202	1-104-129-00	ⓐ 0.015 125V styrol
C103,203	1-131-429-00	ⓐ 470 3.15V tantalum
C104,204		
C105,205	1-102-115-00	Ⓐ 560p

Note: The components identified by shading and mark △ are critical for safety. Replace only with part number specified.

Note: Circled letters (A to Z) are applicable to European models only.

Ref. No.	Part No.	Description
C106,206	1-104-129-00	ⓐ 0.015 125V styrol
C107,207		
C108,208	1-131-295-00	ⓐ 100 6.3V tantalum
C109,209	1-102-074-00	Ⓐ 1000p
C110,210	1-130-145-00	ⓑ 0.016 800V polyethylene (2%)
C111,211	1-102-973-00	Ⓐ 100p
C112,212	1-130-146-00	ⓐ 0.056 800V polyethylene (2%)
C113,213	1-102-822-00	Ⓐ 390p
C114,214	1-130-084-00	ⓓ 2.2 100V polyethylene
C301	1-131-239-00	ⓑ 6.8 35V tantalum
C302	1-121-941-00	ⓑ 470 35V elect
C303	1-123-074-00	Ⓐ 2200 10V elect
C304	1-131-449-00	ⓐ 3.3 16V tantalum
C305	1-123-074-00	Ⓐ 2200 10V elect
C306	1-131-449-00	ⓐ 3.3 16V tantalum
C307	1-123-187-00	Ⓐ 10 25V elect
C308	1-130-084-00	ⓓ 2.2 100V polyethylene
C309	1-121-935-00	ⓑ 100 25V elect
C310	1-131-239-00	ⓑ 6.8 35V tantalum
C311	1-121-941-00	ⓑ 470 35V elect
C312	1-123-074-00	Ⓐ 2200 10V elect
C313	1-131-449-00	ⓐ 3.3 16V tantalum
C314	1-123-074-00	Ⓐ 2200 10V elect
C315	1-131-449-00	ⓐ 3.3 16V tantalum
C316	1-123-187-00	Ⓐ 10 25V elect
C317	1-130-084-00	ⓓ 2.2 100V polyethylene
C401	1-130-140-00	ⓑ 0.039 100V polyethylene mylar
C402	1-108-800-00	Ⓐ 0.0047
C403,404	1-102-491-00	Ⓐ 51p
C405-407	1-101-923-00	Ⓐ 0.01
C408,409	1-131-295-00	ⓐ 100 6.3V tantalum
C410	1-101-923-00	Ⓐ 0.01
C411	1-121-391-00	Ⓐ 1 50V elect
C412	1-123-197-00	Ⓐ 100 6.3V elect
C413	1-123-196-00	Ⓐ 100 10V elect
C414	1-121-391-00	Ⓐ 1 50V elect
C415	1-123-228-00	ⓑ 1 50V elect
C416	1-108-804-00	Ⓐ 0.01 mylar
C417	1-131-218-00	ⓑ 3.3 35V elect

Ref. No.	Part No.	Description
C418	1-108-808-00	Ⓐ 0.022 mylar
C419	1-123-192-00	Ⓐ 47 16V elect
C420,421	1-108-804-00	Ⓐ 0.01 mylar
C422	1-130-140-00	ⓑ 0.039 100V polyethylene
C423	1-108-816-00	ⓑ 0.1 mylar
C424	1-108-804-00	Ⓐ 0.01 mylar
C425	1-123-021-00	ⓑ 0.47 50V elect (nonpolarized)
C426	1-108-812-00	Ⓐ 0.047 mylar
C427	1-108-816-00	ⓑ 0.1 mylar
C428,429	1-123-228-00	ⓑ 1 50V elect
C430	1-108-808-00	Ⓐ 0.022 mylar
C431	1-123-192-00	Ⓐ 47 16V elect
C432	1-108-804-00	Ⓐ 0.01 mylar
C433	1-108-803-00	Ⓐ 0.0082 mylar
C435	1-121-935-00	ⓑ 100 25V elect
C1501	△1-130-141-00	Ⓐ 0.01 630V polyethylene
C1502,1503	△1-115-149-00	ⓐ 0.0015 450V paper
C1504	△1-123-290-00	ⓑ 10 400V elect
C1505	△1-108-595-00	Ⓐ 0.047 mylar
C1506	△1-108-599-00	Ⓐ 0.068 mylar
C1507	△1-130-141-00	Ⓐ 0.01 630V polyethylene
C1508,1509	△1-121-656-00	ⓑ 330 50V elect
C1510,1511	△1-121-417-00	ⓑ 100 50V elect
C1512,1513	△1-108-969-00	ⓑ 0.22 250V film
C1514	△1-102-973-00	Ⓐ 100p 500V mica
C601	1-101-918-00	Ⓐ 1000p
C602	1-131-212-00	ⓑ 0.33 35V tantalum
C603,604	1-123-021-00	ⓑ 0.47 50V elect (nonpolarized)
C605	1-121-391-00	Ⓐ 1 50V elect
C606	1-123-228-00	ⓑ 1 50V elect
C607	1-123-189-00	Ⓐ 33 25V elect
C608	1-121-981-00	ⓑ 220 6.3V elect
C609	1-121-391-00	Ⓐ 1 50V elect
C610	1-123-044-00	ⓑ 33 25V elect
C611	1-121-392-00	Ⓐ 3.3 25V elect
C612-614	1-121-391-00	Ⓐ 1 50V elect
C615	1-121-651-00	Ⓐ 10 16V elect
C616	1-131-211-00	ⓑ 0.22 35V tantalum
C617	1-123-193-00	Ⓐ 100 16V elect

Note: The components identified by shading and mark △ are critical for safety. Replace only with part number specified.

Note: Circled letters (A to Z) are applicable to European models only.

Ref. No.	Part No.	Description
C618	1-121-935-00 (B) 100	25V elect
C619	1-123-187-00 (A) 10	25V elect
C620,621	1-121-935-00 (B) 100	25V elect
C622	1-108-810-00 (A) 0.033	100V mylar
C623	1-101-918-00 (A) 1000p	
C702,703	△1-125-136-00 (E) 2200	50V elect
C704,705	△1-123-067-00 (A) 2200	25V elect
C706	△1-123-254-00 (B) 10	250V elect
C707-709	1-123-183-00 (A) 10	50V elect
C710	1-123-059-00 (B) 100	50V elect
C711	1-123-228-00 (B) 1	50V elect
C712	1-121-935-00 (B) 100	25V elect
C713	1-123-059-00 (B) 100	50V elect
C714	1-123-228-00 (B) 1	50V elect
C715,716	△1-125-136-00 (E) 2200	50V elect
C751	△1-129-773-00 (A) 0.047	200V polyethylene
C752,753	△1-123-291-00 (G) 680	200V elect
C791	△1-115-149-00 (C) 0.0015	450V paper
C792	△1-129-755-00 (B) 0.047	400V polyethylene
C901	1-102-981-00 (A) 300p	
C902	1-102-973-00 (A) 100p	
C903	1-102-981-00 (A) 300p	
C904	1-102-973-00 (A) 100p	
C905	1-123-187-00 (A) 10	25V elect
C2001,2002	△1-115-147-00 (C) 0.033	450V paper

RESISTORS

All resistors are in ohms. Common ¼W carbon resistors are omitted.

Refer to the list on the last page for their part numbers.

All variable and adjustable resistors have characteristic curve B, unless otherwise noted.
kΩ: 1000Ω

R101,201	1-214-126-00 (A) 560	¼W metal oxide (1%)
R102,202	1-214-110-00 (A) 120	¼W metal oxide (1%)
R103,203		
R104,204	1-214-108-00 (A) 100	¼W metal oxide (1%)
R105,205	1-214-116-00 (A) 220	¼W metal oxide (1%)
R106,206	1-214-112-00 (A) 150	¼W metal oxide (1%)
R107,207	1-244-809-00 (A) 2.2	½W carbon
R108,208	1-214-144-00 (A) 3.3 k	¼W metal oxide (1%)

Ref. No.	Part No.	Description
R109,209	1-214-120-00 (A) 330	¼W metal oxide (1%)
R110,210	1-214-108-00 (A) 100	¼W metal oxide (1%)
R111,211	1-214-164-00 (A) 22 k	¼W metal oxide (1%)
R112,212	1-214-160-00 (A) 15 k	¼W metal oxide (1%)
R113,213	1-214-132-00 (A) 1 k	¼W metal oxide (1%)
R114,214	1-214-180-00 (A) 100 k	¼W metal oxide (1%)
R115,215	1-214-126-00 (A) 560	¼W metal oxide (1%)
R116,216		
R117,217	1-214-164-00 (A) 22 k	¼W metal oxide (1%)
R118,218	1-214-108-00 (A) 100	¼W metal oxide (1%)
R119,219	1-214-147-00 (A) 4.3 k	¼W metal oxide (1%)
R120,220	1-214-119-00 (A) 300	¼W metal oxide (1%)
R121,221	1-214-140-00 (A) 2.2 k	¼W metal oxide (1%)
R122,222	1-214-132-00 (A) 1 k	¼W metal oxide (1%)
R123,223	1-214-174-00 (A) 56 k	¼W metal oxide (1%)
R124,224	1-214-132-00 (A) 1 k	¼W metal oxide (1%)
R125,225	1-214-108-00 (A) 100	¼W metal oxide (1%)
R126,226		
R127,227	1-214-126-00 (A) 560	¼W metal oxide (1%)
R128,228	1-214-180-00 (A) 100 k	¼W metal oxide (1%)
R129,229		
R130,230	1-214-156-00 (A) 10 k	¼W metal oxide (1%)
R131,231	1-214-116-00 (A) 220	¼W metal oxide (1%)
R132,232	1-214-100-00 (A) 47	¼W metal oxide (1%)
R133,233	1-214-116-00 (A) 220	¼W metal oxide (1%)
R134,234	1-214-100-00 (A) 47	¼W metal oxide (1%)
R135,235	1-214-112-00 (A) 150	¼W metal oxide (1%)
R301,302	1-214-148-00 (A) 4.7 k	¼W metal oxide (1%)
R303	1-214-142-00 (A) 2.7 k	¼W metal oxide (1%)
R304	1-214-122-00 (A) 390	¼W metal oxide (1%)
R305	1-214-159-00 (A) 13 k	¼W metal oxide (1%)
R306	1-214-126-00 (A) 560	¼W metal oxide (1%)
R307	1-214-112-00 (A) 150	¼W metal oxide (1%)
R308	1-214-100-00 (A) 47	¼W metal oxide (1%)
R311,312	1-214-140-00 (A) 2.2 k	¼W metal oxide (1%)
R313	1-214-122-00 (A) 390	¼W metal oxide (1%)
R314	1-214-108-00 (A) 100	¼W metal oxide (1%)
R315	1-214-116-00 (A) 220	¼W metal oxide (1%)
R316,317	1-214-148-00 (A) 4.7 k	¼W metal oxide (1%)
R318	1-214-142-00 (A) 2.7 k	¼W metal oxide (1%)

Note: The components identified by shading and mark △ are critical for safety. Replace only with part number specified.

Note: Circled letters (A to Z) are applicable to European models only.

Ref. No.	Part No.	Description
R319	1-214-122-00 (A) 390	¼W metal oxide (1%)
R320	1-214-126-00 (A) 560	¼W metal oxide (1%)
R321	1-214-159-00 (A) 13 k	¼W metal oxide (1%)
R322	1-214-112-00 (A) 150	¼W metal oxide (1%)
R323	1-214-100-00 (A) 47	¼W metal oxide (1%)
R326,327	1-214-140-00 (A) 2.2 k	¼W metal oxide (1%)
R328	1-214-108-00 (A) 100	¼W metal oxide (1%)
R329	1-214-122-00 (A) 390	¼W metal oxide (1%)
R401	1-214-156-00 (A) 10 k	¼W metal oxide (1%)
R402	1-214-132-00 (A) 1 k	¼W metal oxide (1%)
R403	1-214-156-00 (A) 10 k	¼W metal oxide (1%)
R408	1-214-162-00 (A) 18 k	¼W metal oxide (1%)
R409	1-214-176-00 (A) 68 k	¼W metal oxide (1%)
R471	1-214-162-00 (A) 18 k	¼W metal oxide (1%)
R472	1-214-176-00 (A) 68 k	¼W metal oxide (1%)
R475	1-214-151-00 (A) 6.2 k	¼W metal oxide (1%)
R476	1-214-144-00 (A) 3.3 k	¼W metal oxide (1%)
R477	1-214-151-00 (A) 6.2 k	¼W metal oxide (1%)
R478	1-214-144-00 (A) 3.3 k	¼W metal oxide (1%)
R622	(A)1-206-642-00 (A) 120	2W metal oxide (nonflammable)
R631	(A)1-206-640-00 (A) 100	2W metal oxide (nonflammable)
R701-703	(A)1-244-849-00 (A) 100	½W carbon
R704	1-244-869-00 (A) 680	½W carbon
R709	(A)1-206-672-00 (A) 2.2 k	2W metal oxide (nonflammable)
R751,752	(A)1-246-529-00 (A) 220 k	¼W carbon
R903	1-214-180-00 (A) 100 k	¼W metal oxide (1%)
R904	1-214-168-00 (A) 33 k	¼W metal oxide (1%)
R905	1-214-180-00 (A) 100 k	¼W metal oxide (1%)
R906	1-214-168-00 (A) 33 k	¼W metal oxide (1%)
R907-910	1-214-180-00 (A) 100 k	¼W metal oxide (1%)
R1502	(A)1-214-167-00 (A) 30 k	¼W metal oxide (1%)
R1503	(A)1-214-128-00 (A) 680	¼W metal oxide (1%)
R1504,1505	(A)1-214-142-00 (A) 2.7 k	¼W metal oxide (1%)
R1506	(A)1-212-369-00 (B) 5.6	1W metal oxide
R1507	(A)1-212-356-00 (B) 0.47	1W metal oxide (nonflammable)
R1510		
RV101,201	1-224-247-XX (C) 100, adjustable; dc balance	

Ref. No.	Part No.	Description
RV401	1-224-491-00 (B) 22 k, adjustable; 33 rpm osc freq.	
RV402	1-224-661-00 (B) 47 k, adjustable; 45 rpm osc freq.	
RV403	1-224-491-00 (B) 22 k, adjustable; 33 rpm speed	
RV404	1-224-661-00 (B) 47 k, adjustable; 45 rpm speed	
RV405	1-224-489-00 (B) 2.2 k, adjustable; gain	
RV406	1-224-660-00 (B) 1 k, adjustable; gain	
RV407	1-224-490-00 (B) 4.7 k, adjustable; offset	
RV408	1-224-490-00 (B) 4.7 k, adjustable; offset	
RV601	1-224-490-00 (B) 4.7 k, adjustable; auto return	
RV751	1-226-150-00 (B) 20 k, variable with switch; PITCH	
MISCELLANEOUS		
CNJ1	(A)1-509-547-00 (B) Connector, 3-p; AC IN	
CNJ2	1-509-991-00 (B) Socket, 11-p; REMOTE CONTROL	
F1	(A)1-532-237-00 (B) Fuse, 3.15 AT	
F2	(A)1-532-259-00 (B) Fuse, 1.6 AT	
F3,4	(A)1-532-273-00 (B) Fuse, 250 mA	
F5-7	(A)1-532-469-00 (C) Fuse, 100 mA	
J901-904	1-507-416-XX (C) Pin Jack, 4-p; PHONO, LINE OUT	
M1	A-4608-034-A (Z) Motor (A) Ass'y	
M2	8-835-001-XX (K) Motor (B), DNF-1001A	
MGH	1-543-079-00 (I) Head, speed detecting	
NL1	(A)1-519-138-11 (G) Lamp, neon	
PC	1-800-343-00 (C) CdS	
PL1	1-518-234-00 (B) Lamp, 6V 100 mA	
PM1	1-454-187-00 (F) Solenoid, brake	
RY401	1-515-296-00 (F) Relay	
RY701	1-515-278-00 (F) Relay	
RY901	1-515-294-11 (F) Relay, reed	
S5	(A)1-552-295-12 (F) Switch, rotary; POWER	
S6	1-516-657-00 (C) Switch, miniature; return	
S901	1-552-296-00 (K) Switch, rotary; AMP SELECTOR	
S902,903	1-552-297-00 (G) Switch, rotary; LOAD	
X401	1-527-304-00 (F) Crystal	

Note: The components identified by shading and mark (A) are critical for safety. Replace only with part number specified.

Note: Circled letters (A to Z) are applicable to European models only.

<u>Ref. No.</u>	<u>Part No.</u>	<u>Description</u>
	1-452-138-00	(G) Magnet
	1-533-051-XX	(A) Holder, cylindrical lamp
	1-536-401-XX	(A) Terminal Strip, 1L1
	1-551-232-00	(M) Cord with Connector, for remote control unit
	1-561-094-00	(K) Connector
	1-586-737-00	(C) Remote Control Unit

PACKING MATERIALS AND ACCESSORIES

<u>Part No.</u>	<u>Description</u>
X-2219-805-0	(C) Brush Ass'y
1-551-315-00	(H) Cord, connection; RK-112
3-701-616-00	(A) Bag, plastic
3-701-620-00	(A) Bag, plastic
3-770-427-11	(L) Manual, instruction
3-793-395-14	(A) Gauge, tracking error
3-794-154-11	(M) Booklet, technical information
4-808-461-00	(E) Adaptor, 45 rpm
4-844-442-00	(C) Bag, plastic
4-847-092-00	(C) Screwdriver
4-855-176-00	(C) Screw, turntable
4-855-208-00	(C) Escutcheon, spindle
4-855-247-00	(E) Screw, plate
4-855-248-00	(I) Weight, sub
4-855-261-00	(P) Rubber Mat, turntable
4-855-284-00	(T) Turntable
4-855-606-00	(C) Frame
4-855-607-00	(B) Sheet, protection
4-855-608-00	(C) Bag, protection
4-855-609-00	(G) Cushion, upper
4-855-610-00	(E) Cushion, inner
4-855-611-00	(F) Cushion, lower
4-855-612-00	(E) Cushion, turntable
4-855-613-00	(B) Case, accessory
4-855-614-00	(B) Case, accessory
4-855-633-00	(K) Carton
4-855-634-00	(A) Cushion, weight bar
4-855-635-00	(A) Sheet (B), protection

1/4 WATT CARBON RESISTORS (A)

Note: Circled letter (A) is applicable to European models only.

1.0	1-246-401-00	10	1-246-425-00	100	1-246-449-00	1.0k	1-246-473-00	10k	1-246-497-00	100k	1-246-521-00	1.0M	1-246-545-00
1.1	1-246-402-00	11	1-246-426-00	110	1-246-450-00	1.1k	1-246-474-00	11k	1-246-498-00	110k	1-246-522-00	1.1M	1-210-814-00
1.2	1-246-403-00	12	1-246-427-00	120	1-246-451-00	1.2k	1-246-475-00	12k	1-246-499-00	120k	1-246-523-00	1.2M	1-210-815-00
1.3	1-246-404-00	13	1-246-428-00	130	1-246-452-00	1.3k	1-246-476-00	13k	1-246-500-00	130k	1-246-524-00	1.3M	1-210-816-00
1.5	1-246-405-00	15	1-246-429-00	150	1-246-453-00	1.5k	1-246-477-00	15k	1-246-501-00	150k	1-246-525-00	1.5M	1-210-817-00
1.6	1-246-406-00	16	1-246-430-00	160	1-246-454-00	1.6k	1-246-478-00	16k	1-246-502-00	160k	1-246-526-00	1.6M	1-210-818-00
1.8	1-246-407-00	18	1-246-431-00	180	1-246-455-00	1.8k	1-246-479-00	18k	1-246-503-00	180k	1-246-527-00	1.8M	1-210-819-00
2.0	1-246-408-00	20	1-246-432-00	200	1-246-456-00	2.0k	1-246-480-00	20k	1-246-504-00	200k	1-246-528-00	2.0M	1-210-820-00
2.2	1-246-409-00	22	1-246-433-00	220	1-246-457-00	2.2k	1-246-481-00	22k	1-246-505-00	220k	1-246-529-00	2.2M	1-210-821-00
2.4	1-246-410-00	24	1-246-434-00	240	1-246-458-00	2.4k	1-246-482-00	24k	1-246-506-00	240k	1-246-530-00	2.4M	1-244-754-00
2.7	1-246-411-00	27	1-246-435-00	270	1-246-459-00	2.7k	1-246-483-00	27k	1-246-507-00	270k	1-246-531-00	2.7M	1-244-755-00
3.0	1-246-412-00	30	1-246-436-00	300	1-246-460-00	3.0k	1-246-484-00	30k	1-246-508-00	300k	1-246-532-00	3.0M	1-244-756-00
3.3	1-246-413-00	33	1-246-437-00	330	1-246-461-00	3.3k	1-246-485-00	33k	1-246-509-00	330k	1-246-533-00	3.3M	1-244-757-00
3.6	1-246-414-00	36	1-246-438-00	360	1-246-462-00	3.6k	1-246-486-00	36k	1-246-510-00	360k	1-246-534-00	3.6M	1-244-758-00
3.9	1-246-415-00	39	1-246-439-00	390	1-246-463-00	3.9k	1-246-487-00	39k	1-246-511-00	390k	1-246-535-00	3.9M	1-244-759-00
4.3	1-246-416-00	43	1-246-440-00	430	1-246-464-00	4.3k	1-246-488-00	43k	1-246-512-00	430k	1-246-536-00	4.3M	1-244-760-00
4.7	1-246-417-00	47	1-246-441-00	470	1-246-465-00	4.7k	1-246-489-00	47k	1-246-513-00	470k	1-246-537-00	4.7M	1-244-761-00
5.1	1-246-418-00	51	1-246-442-00	510	1-246-466-00	5.1k	1-246-490-00	51k	1-246-514-00	510k	1-246-538-00	5.1M	1-244-762-00
5.6	1-246-419-00	56	1-246-443-00	560	1-246-467-00	5.6k	1-246-491-00	56k	1-246-515-00	560k	1-246-539-00		
6.2	1-246-420-00	62	1-246-444-00	620	1-246-468-00	6.2k	1-246-492-00	62k	1-246-516-00	620k	1-246-540-00		
6.8	1-246-421-00	68	1-246-445-00	680	1-246-469-00	6.8k	1-246-493-00	68k	1-246-517-00	680k	1-246-541-00		
7.5	1-246-422-00	75	1-246-446-00	750	1-246-470-00	7.5k	1-246-494-00	75k	1-246-518-00	750k	1-246-542-00		
8.2	1-246-423-00	82	1-246-447-00	820	1-246-471-00	8.2k	1-246-495-00	82k	1-246-519-00	820k	1-246-543-00		
9.1	1-246-424-00	91	1-246-448-00	910	1-246-472-00	9.1k	1-246-496-00	91k	1-246-520-00	910k	1-246-544-00		

HARDWARE NOMENCLATURE

Screw:

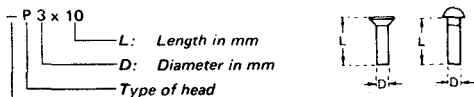

Indicated slotted-head only.
Unless otherwise indicated, it means cross-recessed head (Phillips type).

Nut, Washer, Retaining ring:

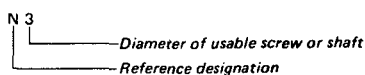

Reference Designation	Shape	Description	Remarks
SCREWS			
P		pan-head screw	binding-head (B) screw for replacement
PWH		pan-head screw with washer face	binding-head (B) screw and flat washer for replacement
PS PSP		pan-head screw with spring washer	binding-head (B) screw and spring washer for replacement
PSW PSPW		pan-head screw with spring and flat washers	binding-head (B) screw and spring and flat washers for replacement
R		round-head screw	binding-head (B) screw for replacement
K		flat-countersunk-head screw	
RK		oval-countersunk-head screw	
B		binding-head screw	
T		truss-head screw	binding-head (B) screw for replacement
F		flat-fillister-head screw	
RF		fillister-head screw	
BV		brazer-head screw	

Reference Designation	Shape	Description	Remarks
SELF-TAPPING SCREWS			
TA		self-tapping screw	ex: TA, P 3 x 10
PTP		pan-head self-tapping screw	binding-head self-tapping (TA, B) screw for replacement
PTPWH		pan-head self-tapping screw with washer face	binding-head self-tapping (TA, B) screw and flat washer for replacement
PTTWH		pan-head thread-rolling screw with washer face	binding-head (B) screw and flat washer for replacement
SET SCREWS			
SC		set screw	
SC		hexagon-socket set screw	ex: SC 2.6 x 4, hexagon socket
NUT			
N		nut	
WASHERS			
W		flat washer	
SW		spring washer	
LW		internal-tooth lock washer	ex: LW3, internal
LW		external-tooth lock washer	ex: LW3, external
RETAINING RINGS			
E		retaining ring	
G		grip-type retaining ring	

Sony Corporation

© 1979

- 46 -