

SCD-CE595

SERVICE MANUAL

Ver. 1.1 2005.05

US Model
Canadian Model
AEP Model
UK Model



Model Name Using Similar Mechanism	NEW
CD Mechanism Type	CDM79C-DVBU51
Optical Pick-up Name	DBU-3

SPECIFICATIONS

When a Super Audio CD is played

Playing frequency range	2 Hz to 100 kHz
Frequency response	2 Hz to 40 kHz (-3 dB)
Dynamic range	100 dB or more
Total harmonic distortion rate	0.0035 % or less
Wow and flutter	Value of measurable limit (±0.001 % W PEAK) or less

When a CD is played

Frequency response	2 Hz to 20 kHz
Dynamic range	96 dB or more
Total harmonic distortion rate	0.0039 % or less
Wow and flutter	Value of measurable limit (±0.001 % W PEAK) or less

Output connector

	Jack type	Output level	Load impedance
ANALOG	Phono	2 Vrms (at 50 kilohms)	Over 10 kilohms
5 1CH OUT	jacks		
DIGITAL (CD) OUT	Square optical	-18 dBm	(Light emitting wave length: 660 nm)
OPTICAL* output connector			

* Output only the audio signals of the CD

General

Laser	Semiconductor laser (Super Audio CD: $\lambda = 650$ nm) (CD: $\lambda = 780$ nm) Emission duration: continuous
Power requirements	
US, Canadian:	120 V AC, 60 Hz
AEP, UK:	230 V AC, 50/60 Hz
Power consumption	15 W
Dimensions (w/h/d)	430 × 110 × 420 mm incl projecting parts
Mass (approx)	5.5 kg

Supplied accessories

Audio connecting cord	Red and White × 2 (1)
Remote commander	RM-SX800 (1)
Battery	R6 (size-AA) (2)

Design and specifications are subject to change without notice

SUPER AUDIO CD PLAYER

TABLE OF CONTENTS

1. **SERVICING NOTES** 3

2. **GENERAL** 4

3. **TEST MODE** 6

4. **DIAGRAMS**

4-1. Block Diagram 8

4-2. Printed Wiring Board — RF Section — 9

4-3. Schematic Diagram — RF Section — 10

4-4. Printed Wiring Board — MAIN Section — 11

4-5. Schematic Diagram — MAIN Section (1/4) — 12

4-6. Schematic Diagram — MAIN Section (2/4) — 13

4-7. Schematic Diagram — MAIN Section (3/4) — 14

4-8. Schematic Diagram — MAIN Section (4/4) — 15

4-9. Printed Wiring Board — DISPLAY Section — 16

4-10. Schematic Diagram — DISPLAY Section — 17

4-11. Printed Wiring Board — MD-94 Board Section — 18

4-12. Schematic Diagram — MD-94 Board Section — 19

5. **EXPLODED VIEWS**

5-1. Main Section 22

5-2. Front Panel Section 23

5-3. Chassis Section 24

5-4. CD Mechanism Section (1) (CDM79C-DVBU51) 25

5-5. CD Mechanism Section (2) (CDM79C-DVBU51) 26

6. **ELECTRICAL PARTS LIST** 27

NOTES ON HANDLING THE OPTICAL PICK-UP BLOCK OR BASE UNIT

The laser diode in the optical pick-up block may suffer electrostatic break-down because of the potential difference generated by the charged electrostatic load, etc. on clothing and the human body. During repair, pay attention to electrostatic break-down and also use the procedure in the printed matter which is included in the repair parts. The flexible board is easily damaged and should be handled with care.

NOTES ON LASER DIODE EMISSION CHECK

The laser beam on this model is concentrated so as to be focused on the disc reflective surface by the objective lens in the optical pick-up block. Therefore, when checking the laser diode emission, observe from more than 30 cm away from the objective lens.

CAUTION

Use of controls or adjustments or performance of procedures other than those specified herein may result in hazardous radiation exposure.

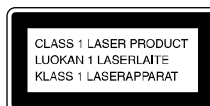

This appliance is classified as a CLASS 1 LASER product This label is located on the rear exterior

LASER DIODE AND FOCUS SEARCH OPERATION CHECK

Carry out the “S curve check” in “CD section adjustment” and check that the S curve waveform is output three times.

Notes on chip component replacement

- Never reuse a disconnected chip component.
- Notice that the minus side of a tantalum capacitor may be damaged by heat.

Flexible Circuit Board Repairing

- Keep the temperature of the soldering iron around 270 °C during repairing.
- Do not touch the soldering iron on the same conductor of the circuit board (within 3 times).
- Be careful not to apply force on the conductor when soldering or unsoldering.

SAFETY-RELATED COMPONENT WARNING!!

COMPONENTS IDENTIFIED BY MARK \triangle OR DOTTED LINE WITH MARK \triangle ON THE SCHEMATIC DIAGRAMS AND IN THE PARTS LIST ARE CRITICAL TO SAFE OPERATION. REPLACE THESE COMPONENTS WITH SONY PARTS WHOSE PART NUMBERS APPEAR AS SHOWN IN THIS MANUAL OR IN SUPPLEMENTS PUBLISHED BY SONY.

ATTENTION AU COMPOSANT AYANT RAPPORT À LA SÉCURITÉ!

LES COMPOSANTS IDENTIFIÉS PAR UNE MARQUE \triangle SUR LES DIAGRAMMES SCHÉMATIQUES ET LA LISTE DES PIÈCES SONT CRITIQUES POUR LA SÉCURITÉ DE FONCTIONNEMENT. NE REMPLACER CES COM- POSANTS QUE PAR DES PIÈCES SONY DONT LES NUMÉROS SONT DONNÉS DANS CE MANUEL OU DANS LES SUPPLÉMENTS PUBLIÉS PAR SONY.

SECTION 1 SERVICING NOTES

SAFETY CHECK-OUT

After correcting the original service problem, perform the following safety check before releasing the set to the customer:
 Check the antenna terminals, metal trim, "metallized" knobs, screws, and all other exposed metal parts for AC leakage.
 Check leakage as described below.

LEAKAGE TEST

The AC leakage from any exposed metal part to earth ground and from all exposed metal parts to any exposed metal part having a return to chassis, must not exceed 0.5 mA (500 microamperes.). Leakage current can be measured by any one of three methods.

1. A commercial leakage tester, such as the Simpson 229 or RCA WT-540A. Follow the manufacturers' instructions to use these instruments.
2. A battery-operated AC milliammeter. The Data Precision 245 digital multimeter is suitable for this job.
3. Measuring the voltage drop across a resistor by means of a VOM or battery-operated AC voltmeter. The "limit" indication is 0.75 V, so analog meters must have an accurate low-voltage scale. The Simpson 250 and Sanwa SH-63Trd are examples of a passive VOM that is suitable. Nearly all battery operated digital multimeters that have a 2 V AC range are suitable. (See Fig. A)

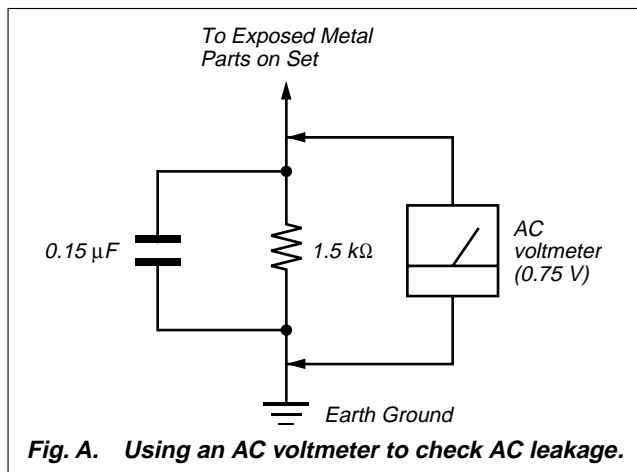

MODEL IDENTIFICATION

– Back Panel –

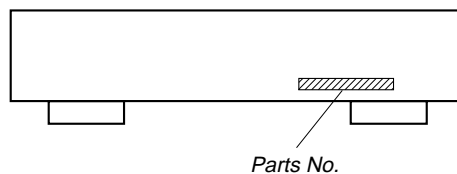

MODEL	Part No.
US Model	4-255-250-0□
Canadian Model	4-255-250-1□
AEP Model	4-255-250-2□
UK Model	4-255-250-3□

HOW TO OPEN THE DISC TRAY WHEN POWER SWITCH TURNS OFF

Insert a tapering driver into the aperture of the unit bottom, and turn in the direction of arrow.

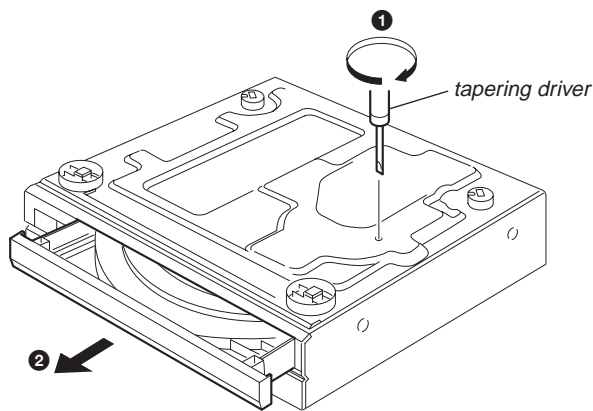

Use a flat (-) head screwdriver to open the disc tray by manual operation. (Flat head screwdriver with nominal blade length of 3mm.)

* To close the disc table, turn the driver in the reverse direction.

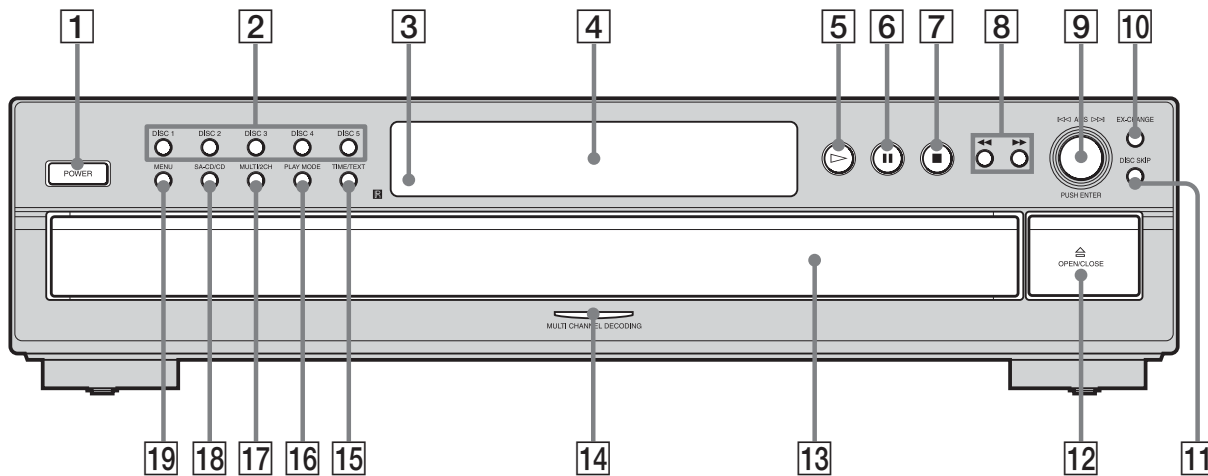

Front Panel



- 1 POWER switch (9)**
- 2 DISC 1-5 buttons (9, 14)**
Press to select the disc directly.
- 3 Remote sensor  (6)**
- 4 Display window (10)**
- 5 ▷ button (9, 13, 14)**
- 6 || button (9)**
- 7 ■ button (9, 15)**
- 8 ◀▶ buttons (13)**
- 9 ◀◀ AMS ▶▶ dial
(AMS: Automatic Music Sensor) (8, 9, 10, 12, 13, 14, 16, 17, 19)**
- 10 EX-CHANGE button (12)**
Press to replace discs while playing a disc.
- 11 DISC SKIP button (9, 12, 14)**
Press to select the disc.
- 12  OPEN/CLOSE button (9)**
- 13 Disc tray (9)**
- 14 MULTI CHANNEL DECODING indicator**
Turns on when you turn on the player, or when the Multi-channel Super Audio CD is loaded and select the multi-channel playback area by pressing MULTI/2CH.
- 15 TIME/TEXT button (11)**
Each time you press the button, the playing time of the track, the remaining time of the disc, or TEXT information appears in the display.
- 16 PLAY MODE button (9, 14)**
Press to select the play mode.
- 17 MULTI/2CH button (5, 10)**
Press to select the playback area when a disc with the 2 channel area and the multi-channel area (page 5) is loaded.
- 18 SA-CD/CD button (5, 9)**
Each time you press the button while playing back a hybrid disc, the layer to be played back switches between the SA-CD layer and the CD layer.
- 19 MENU button (8, 9, 10, 12, 16, 17, 19)**
Press to enter the menu.
Press to exit from the menu and return to the normal display.

Remote

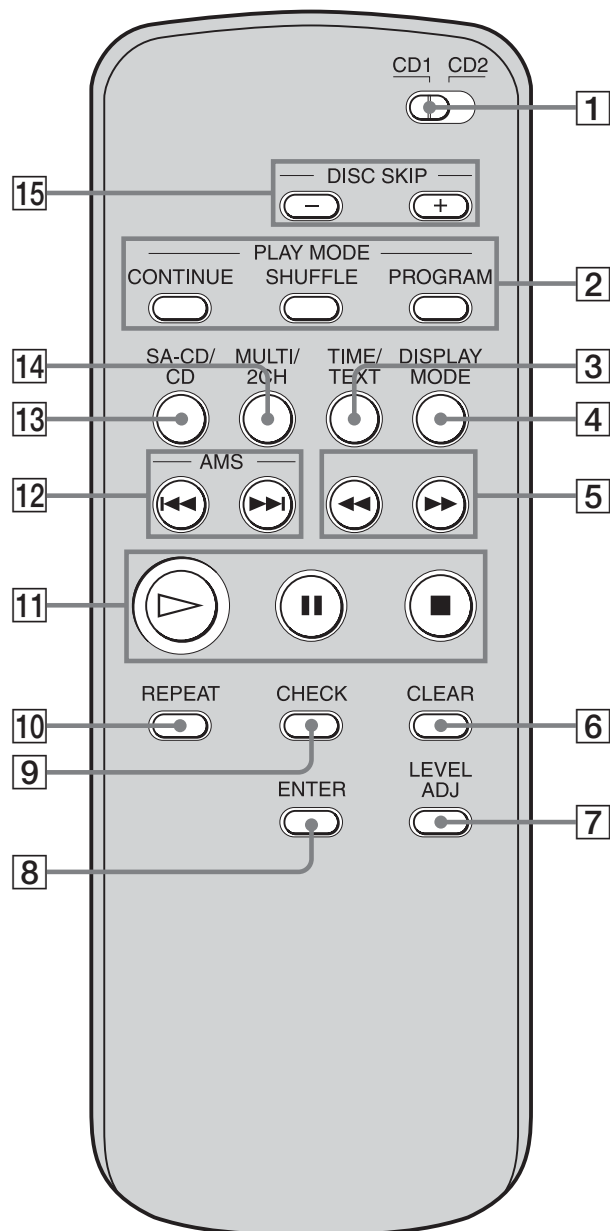

- 1 CD1/2 (command mode) switch (8)**
Select the command mode.
- 2 CONTINUE button (9, 14)**
Press to resume Continuous Play from Shuffle Play or Program Play.
SHUFFLE button (14)
PROGRAM button (14)
- 3 TIME/TEXT button (11)**
Each time you press the button, the playing time of the track, the remaining time of the disc, or TEXT information appears in the display.
- 4 DISPLAY MODE button (12)**
Press to turn the display information off or on.
- 5 <<</>>> buttons (13)**
- 6 CLEAR button (14, 15)**
Press to delete a programed track number.
- 7 LEVEL ADJ button (17)**
Press to adjust the output level balance for the Multi-channel management function (page 15).
- 8 ENTER button (8, 10, 12, 14, 16, 18, 19)**
- 9 CHECK button (15)**
Press to check the programed order.
- 10 REPEAT button (13)**
- 11 ▷ button (9, 13, 14)**
|| button (9)
■ button (9, 15)
- 12 AMS I<<</>>>I buttons (AMS: Automatic Music Sensor) (8, 9, 10, 12, 13, 14, 16, 18, 19)**
- 13 SA-CD/CD button (5, 9)**
Each time you press the button while playing back a hybrid disc, the layer to be played back switches between the SA-CD layer and the CD layer.
- 14 MULTI/2CH button (5, 10)**
Press to select the playback area when a disc with the 2 channel area and the multi-channel area (page 5) is loaded.
- 15 DISC SKIP +/- buttons (9, 12, 14)**
Press to select the disc.

SECTION 3 TEST MODE

1. Setting Method of Test Mode

Press three buttons , **PUSH ENTER** and **POWER** simultaneously, The test mode becomes active. Then all segments of the fluorescent indicator tube are turned on.



2. FL Tube Grid, Segments Check

Procedure:

1. Grid of all segments lights up sequentially starting from 1G to 16G.
2. The vertical line (total 5 lines) of all grids lights up sequentially in the range of 5G to 16 G starting from the left.
3. The horizontal line of (total 7 lines) of all grids lights up sequentially in the range of 5G to 16G starting from the top.

3. Sircs Receive Check

Procedure:

1. The message "SIRCS CHECK" is displayed on the fluorescent indicator tube.
2. With the machine in the status that is set in step 2, press any on the remote commander. The machine enters the key check standby state. (When the  key or the  key is pressed, the reception check is canceled.)

4. Key Check

Procedure:

1. In the key check mode, the fluorescent indicator displays "KEY CHECK**". Each time a button is pressed, "***" value. However, once a button is pressed, it is no longer taken into account.
2. To exit from this mode, the message "JOG CHECK" is displayed.

5. Jog Check

Procedure:

1. After the key check is completed, turn JOG clockwise to turn on the calendar segments sequentially. When the segment "15" is confirmed, turn JOG counter-clockwise that turns off the calendar segment. When the segment "1" is confirmed, this is the end of check.

6. Releasing Method of Test Mode

1. After all the checks are completed, confirm to see that the display "TEST-END" appears. The message indicates that the check is ended normally.
2. Press the **POWER** button to turn off the main power and disconnect the power plug from the wall outlet.

SECTION 4 DIAGRAMS

NOTE FOR PRINTED WIRING BOARDS AND SCHEMATIC DIAGRAMS

Note on Printed Wiring Board:

- : parts extracted from the component side.
- : parts extracted from the conductor side.
- : indicates side identified with part number.
- △ : internal component.
- : Pattern from the side which enables seeing.

Caution:

Pattern face side: Parts on the pattern face side seen from (Side B) the pattern face are indicated.
Parts face side: Parts on the parts face side seen from (Side A) the parts face are indicated.

- Indication of transistor.

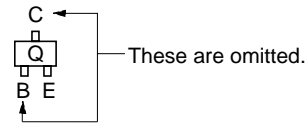

Note Schematic Diagrams.

- All capacitors are in μF unless otherwise noted. (p: pF) 50 WV or less are not indicated except for electrolytics and tantalums.
- All resistors are in Ω and $1/4\text{ W}$ or less unless otherwise specified.
- △ : internal component.
- : panel designation.

Note:

The components identified by mark △ or dotted line with mark △ are critical for safety. Replace only with part number specified.

Note:

Les composants identifiés par une marque △ sont critiques pour la sécurité. Ne les remplacer que par une pièce portant le numéro spécifié.

- — : B+ Line.
- - - - : B- Line.
- Voltages and waveforms are dc with respect to ground under no-signal conditions.
no mark: SACD PLAY
() : CD PLAY
- Voltages are taken with a VOM (Input impedance 10 M Ω). Voltage variations may be noted due to normal production tolerances.
- Waveforms are taken with a oscilloscope. Voltage variations may be noted due to normal production tolerances.
- Circled numbers refer to waveforms.
- Signal path.
⇒ : CD
⇒⇒ : CD DIGITAL OUT (OPTICAL)

• Waveforms

– RF Board –

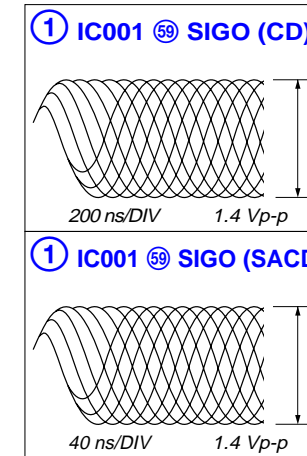

– MAIN Board –

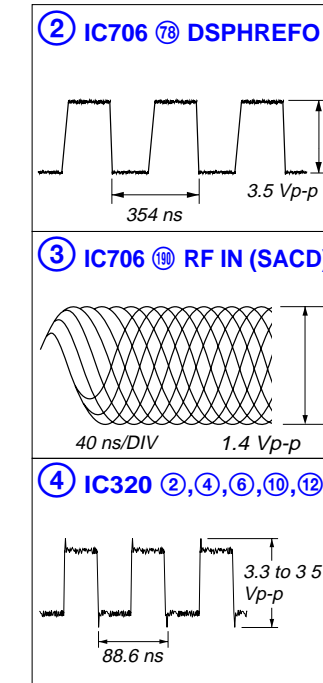

– DISPLAY Board –

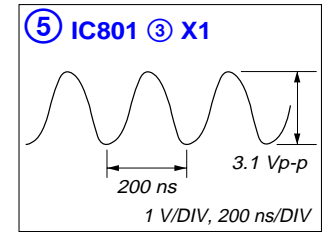

• Circuit Boards Location

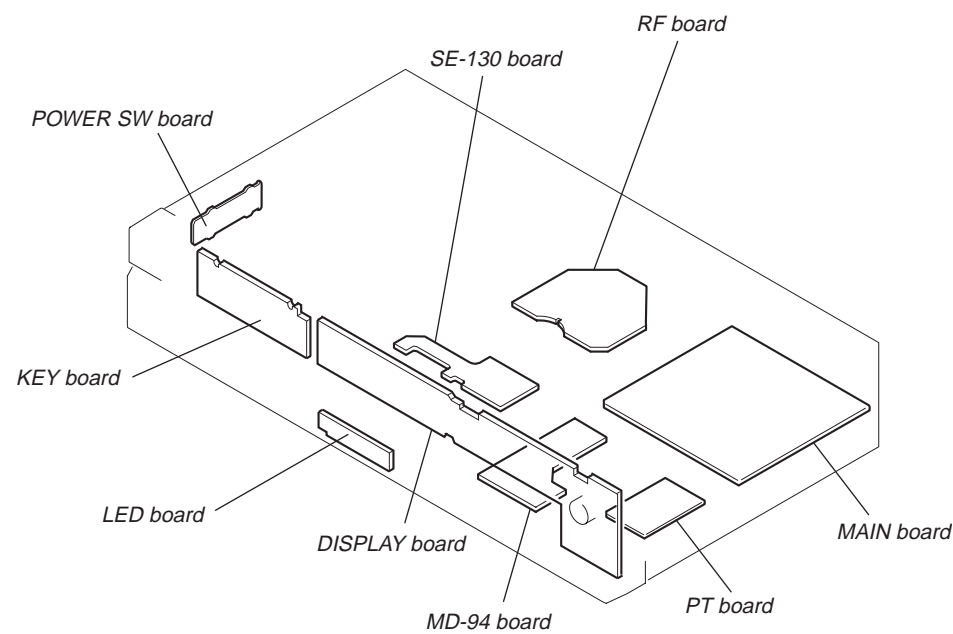

4-1. BLOCK DIAGRAMS

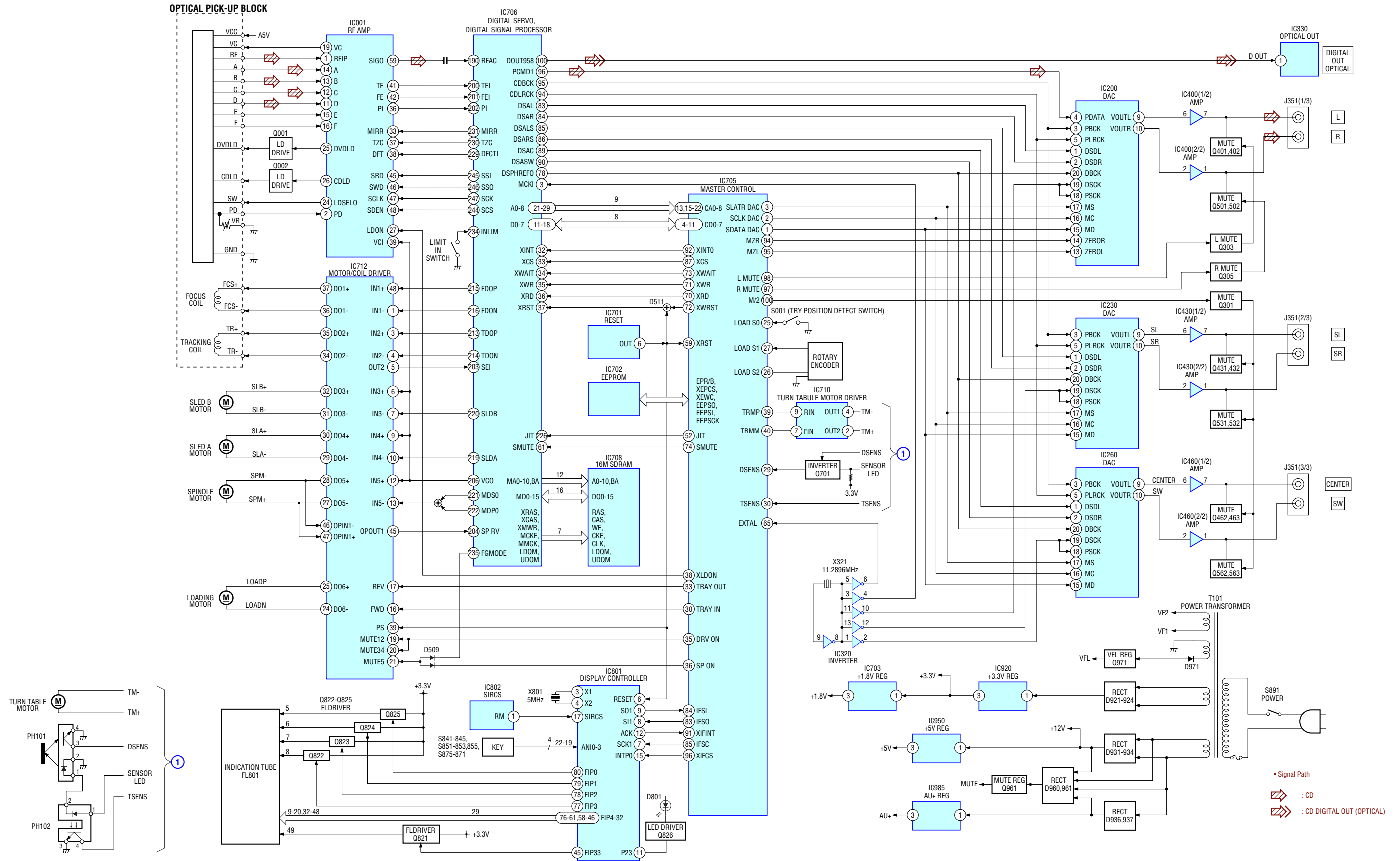

4-3. SCHEMATIC DIAGRAM — RF SECTION — • See page 7 for Waveforms.

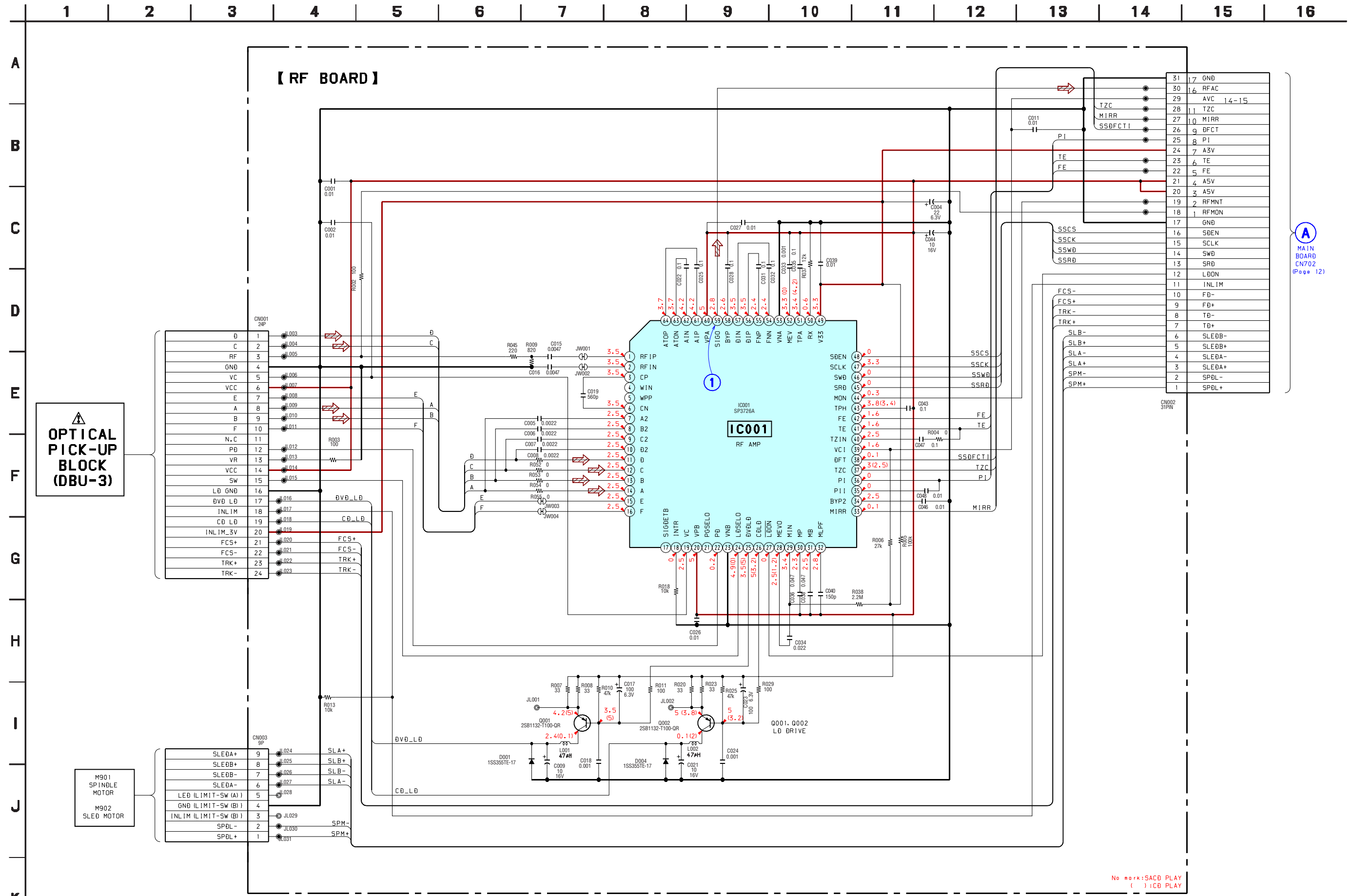

4-4. PRINTED WIRING BOARD — MAIN SECTION —

• See page 7 for Circuit Boards Location.  :Uses unleaded solder.

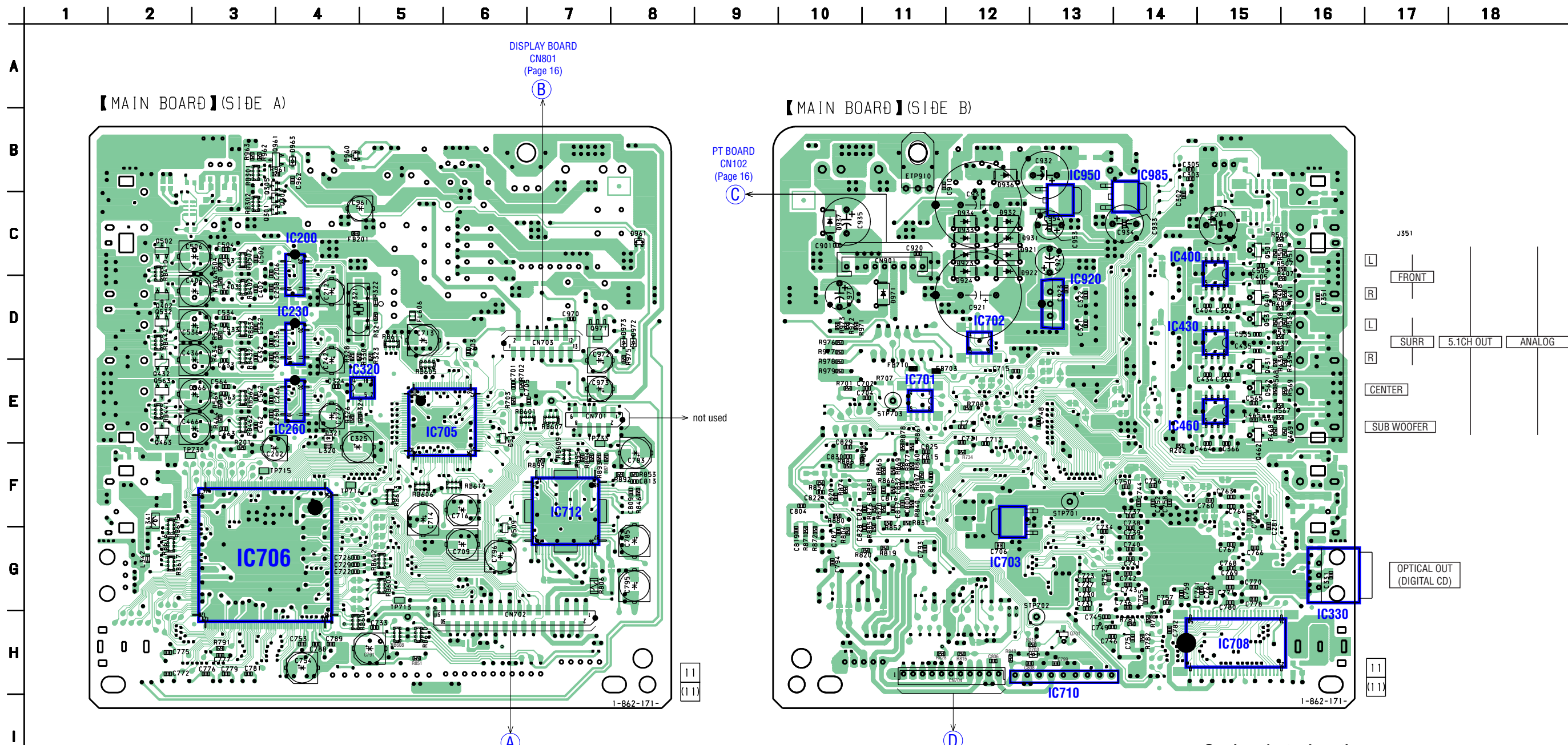

• Semiconductor Location

Ref. No.	Location	Ref. No.	Location	Ref. No.	Location
D321	E-4	IC200	C-4	Q301	C-3
D509	G-6	IC230	D-4	Q303	C-3
D511	E-6	IC260	E-4	Q305	C-3
D703	H-13	IC320	S-5	Q401	C-15
D921	C-12	IC330	G-16	Q402	D-2
D922	C-12	IC400	D-15	Q431	D-15
D923	C-12	IC430	D-15	Q432	E-2
D924	C-12	IC460	E-15	Q462	E-15
D931	C-12	IC701	E-11	Q463	E-2
D932	C-12	IC702	D-12	Q501	C-15
D933	C-12	IC703	F-12	Q502	C-2
D934	C-12	IC705	E-5	Q531	D-15
D936	B-12	IC706	G-3	Q532	D-2
D937	C-10	IC708	H-15	Q562	E-15
D960	B-4	IC710	H-13	Q563	E-2
D961	C-8	IC712	F-7	Q701	H-13
D963	B-4	IC920	D-13	Q961	B-3
D971	D-11	IC950	B-13	Q971	D-7
D972	D-8	IC985	B-14		
D973	D-8				

4-8. SCHEMATIC DIAGRAM — MAIN SECTION (4/4) — • See page 7 for Waveforms.

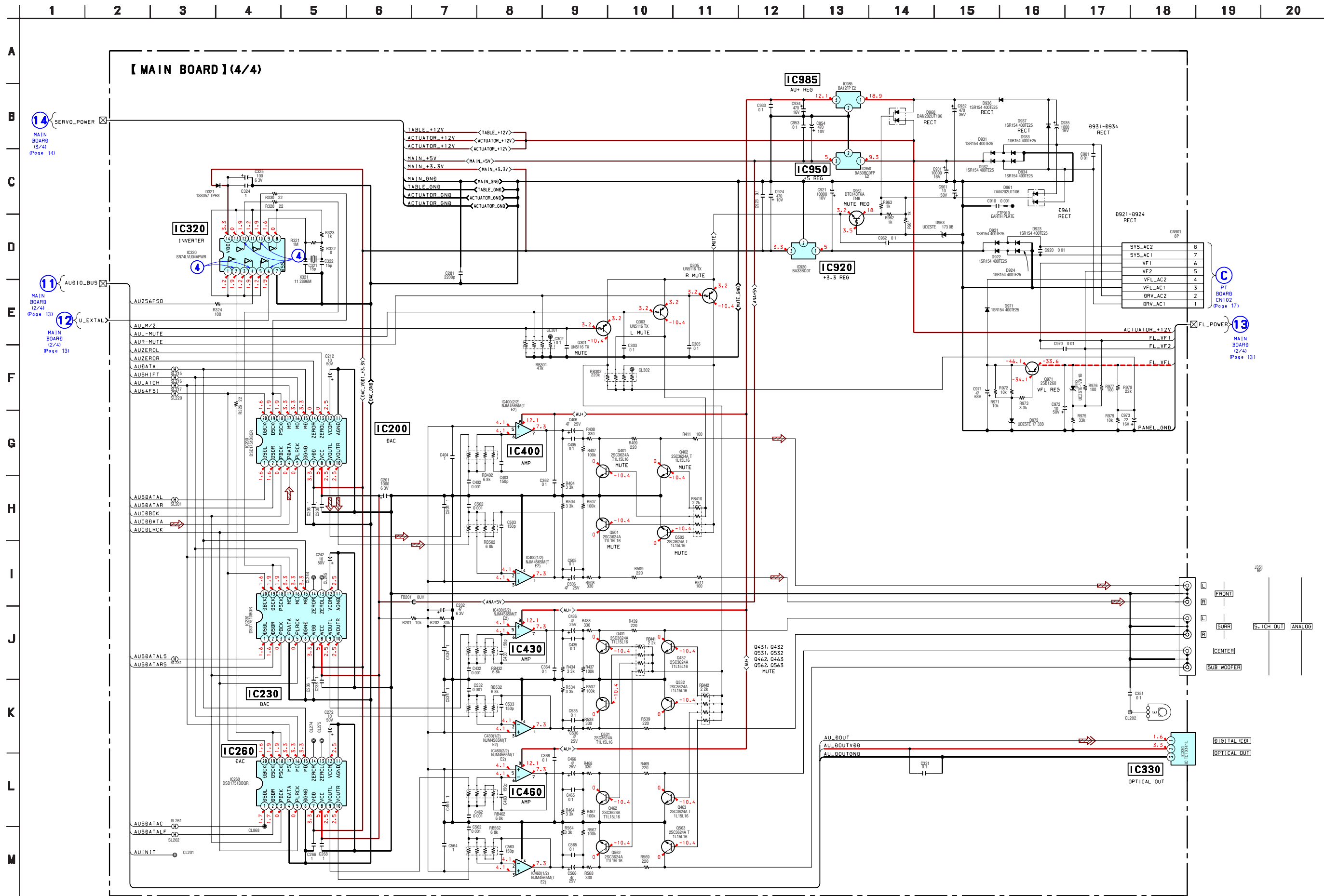

4-9. PRINTED WIRING BOARD — DISPLAY SECTION — • See page 7 for Circuit Boards Location.  :Uses unleaded solder.

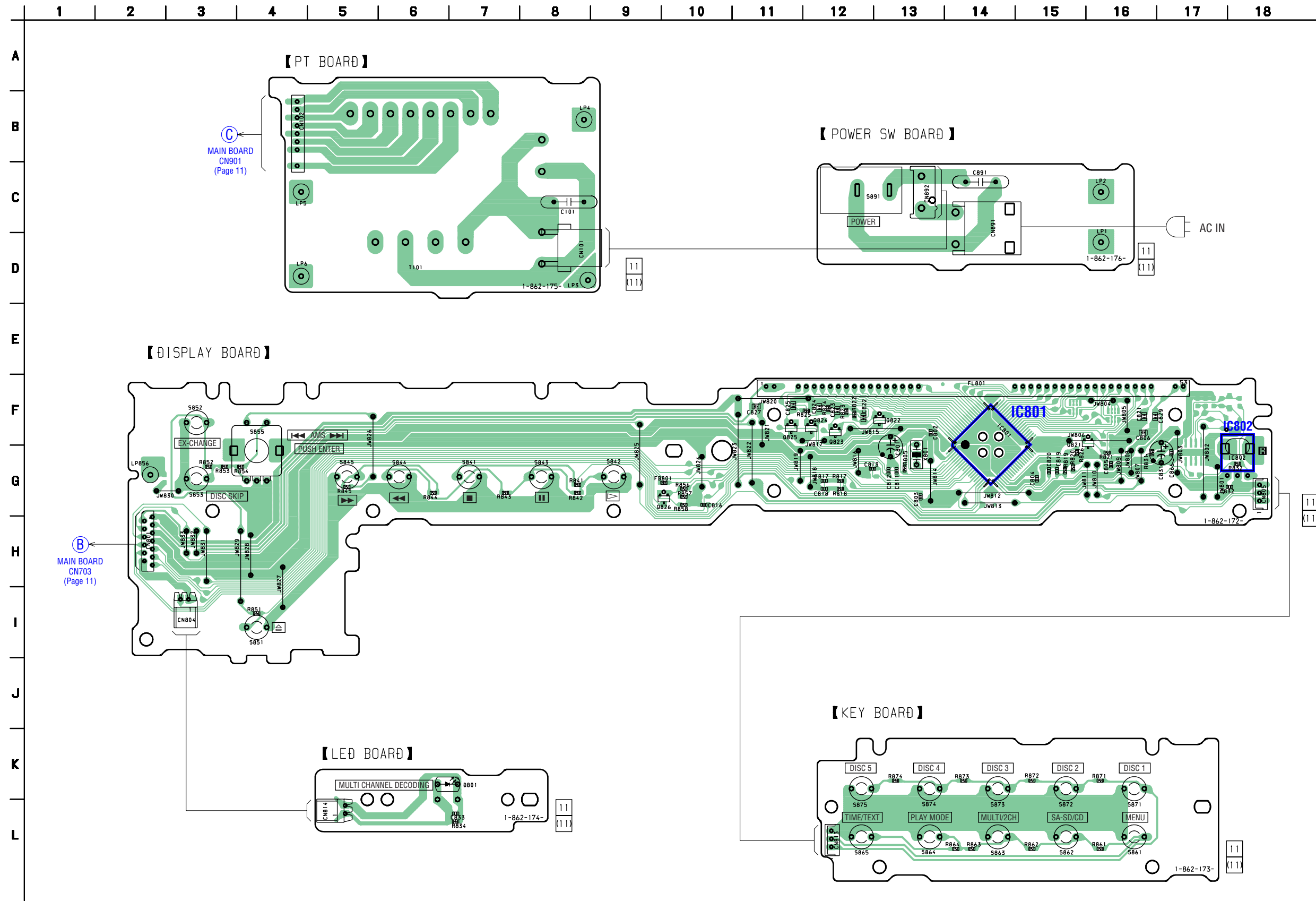

• Semiconductor Location

Ref. No.	Location
IC801	G-14
IC802	G-18
Q821	G-15
Q822	F-13
Q823	F-12
Q824	F-12
Q825	F-11
Q826	G-10

4-10. SCHEMATIC DIAGRAM — DISPLAY SECTION — • See page 7 for Waveforms.

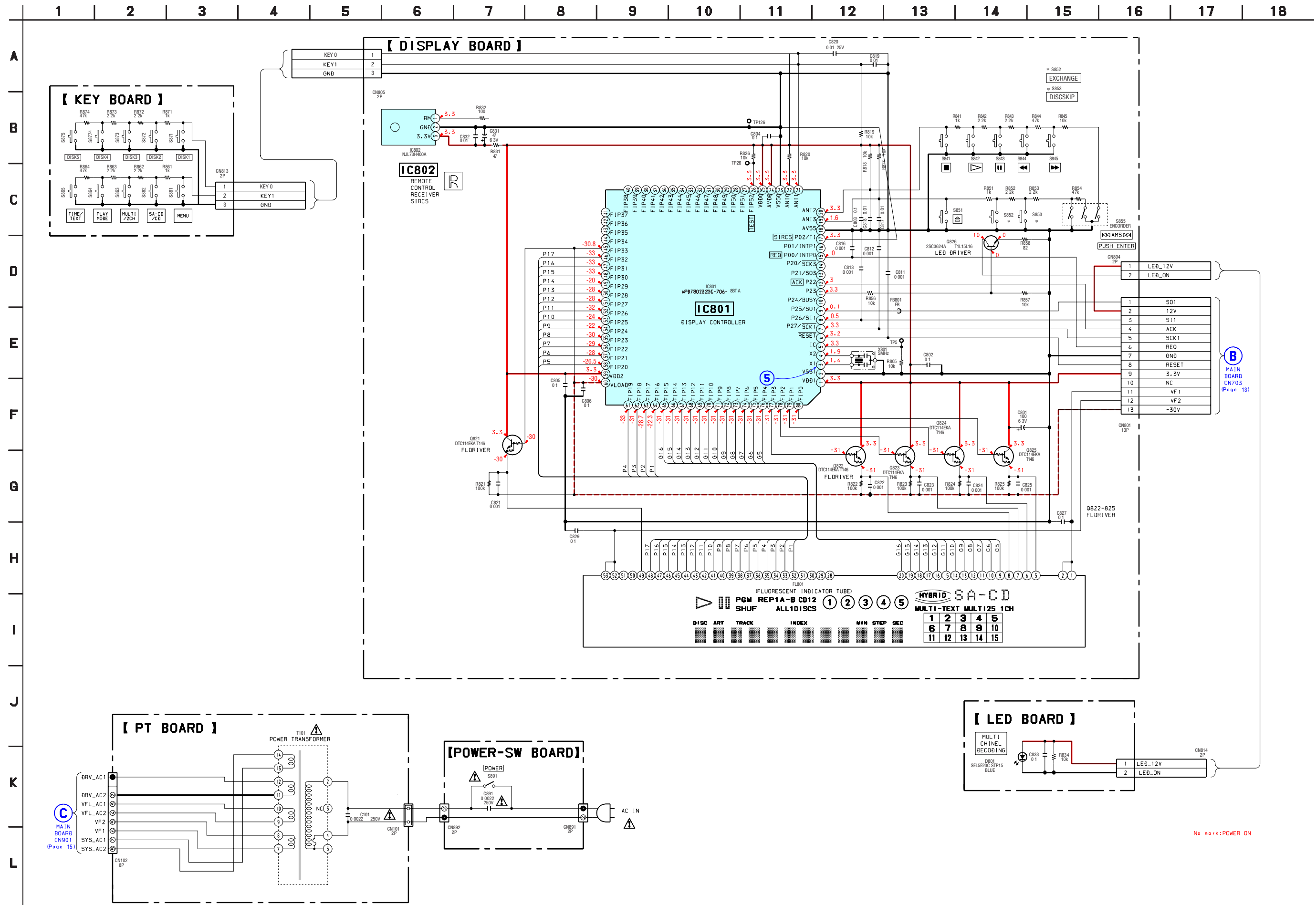

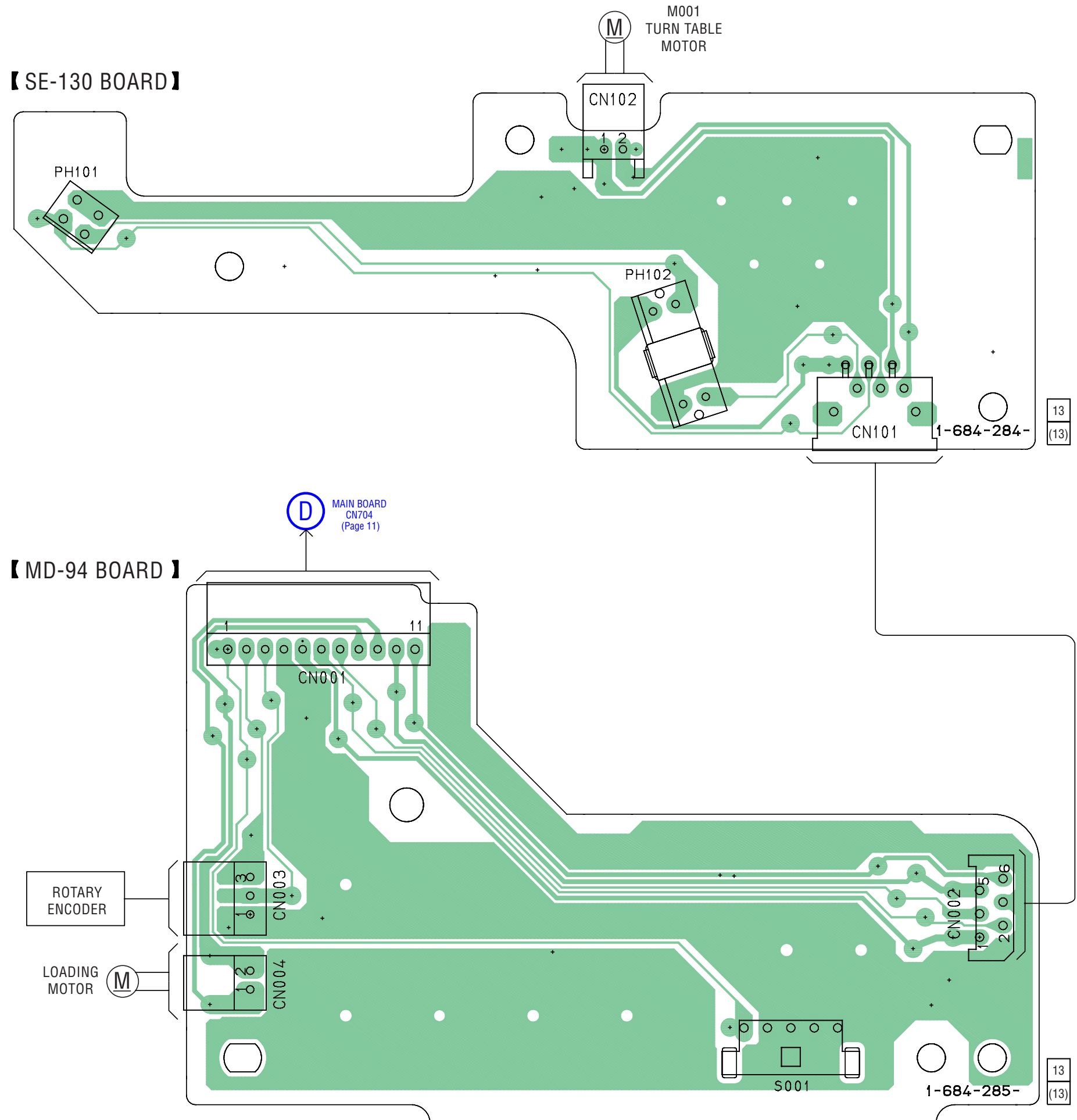

4-12. SCHEMATIC DIAGRAM — MD-94 BOARD SECTION —

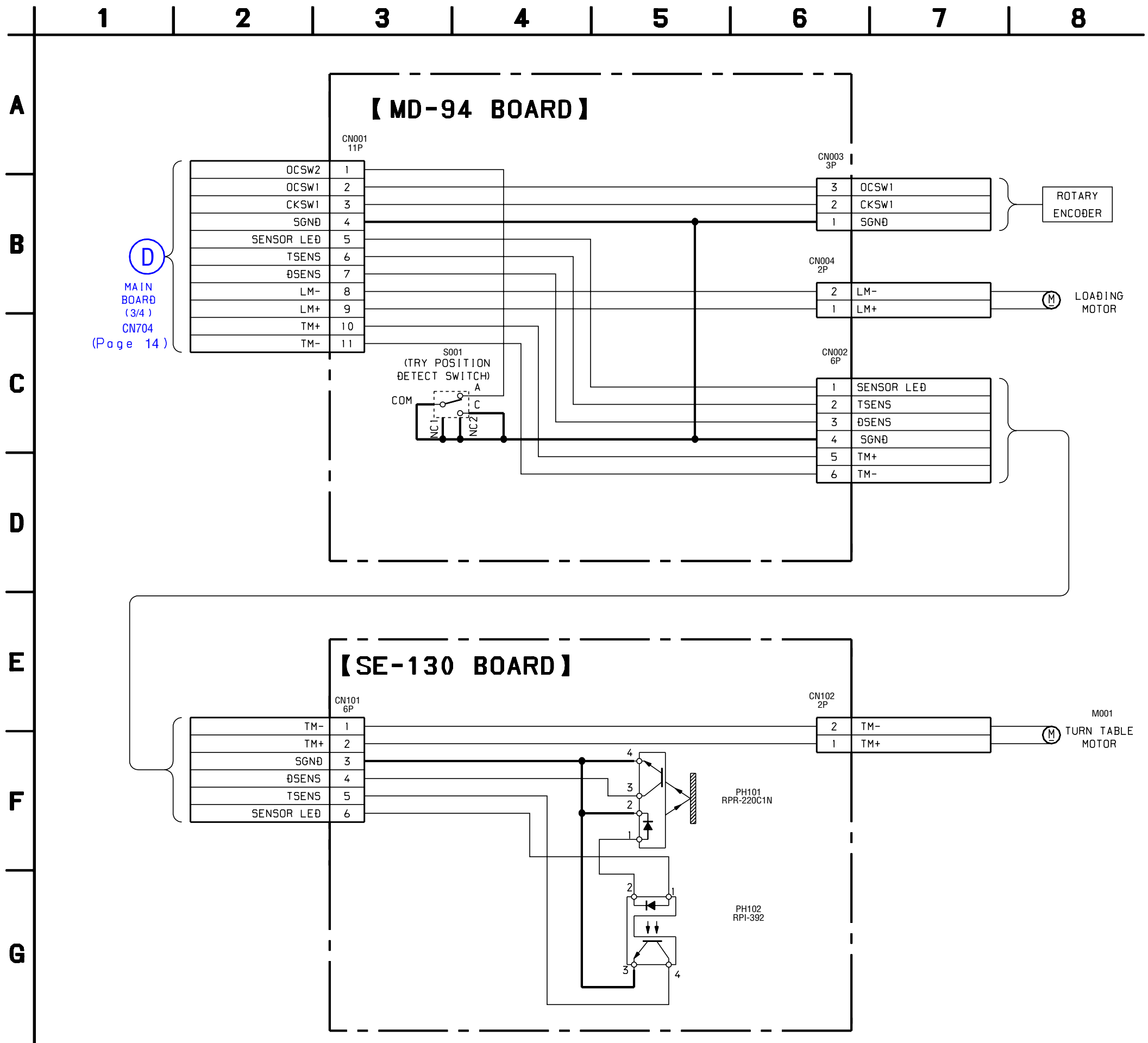

• IC Block Diagrams

– MAIN Board –

IC701 M51957BFP-600C

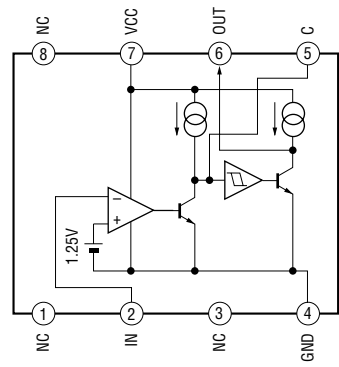

IC702 BR9040F-WF2

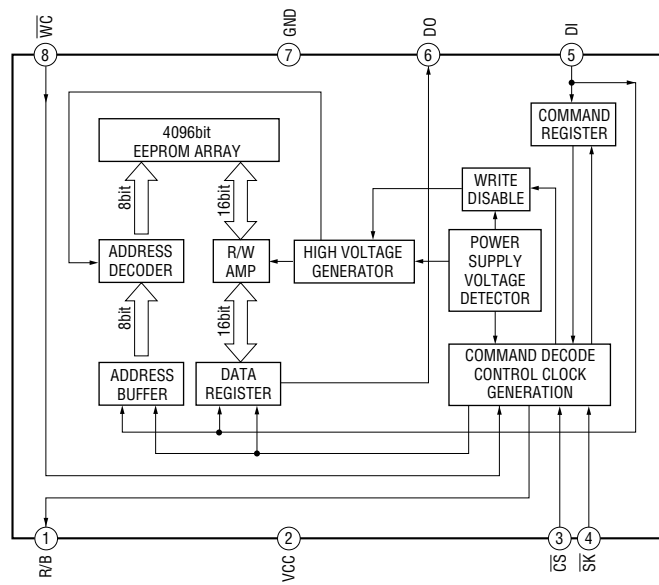

• IC Pin Function Description

• MAIN BOARD IC705 HD6432238RN51TEV (SYSTEM CONTROLLER)

Pin No.	Pin Name	I/O	Description
1	SDATA DAC	O	Data output to the DAC (IC200)
2	SCLK DAC	O	Clock output to the DAC (IC200)
3	SLATR DAC	O	Latch (R-ch) output to the DAC (IC200)
4 to 11	CD0 to 7	I/O	Data Bus to the Digital Servo Processor (IC706)
12	CVCC	—	Power supply terminal (+3.3V)
13	CA0	O	Address Bus to the Digital Servo Processor (IC706)
14	VSS	—	Ground terminal
15 to 22	CA1 to 8	O	Address Bus to the Digital Servo Processor (IC706)
23	PB1	—	Not used (open)
24	PB2	—	Not used (open)
25	LOAD S0	I	DISK cyecking select (S0)
26	LOAD S1	I	TRAY (S2:OPEN)
27	LOAD S2	I	TRAY (S1:TURN)
28	TSENS	I	T sens signal input
29	DSENS	I	DISK sens signal input
30	TRAY IN	O	TRAY in control output to the Motor Driver (IC712)
31	RS232CTX	O	PC serial signal
32	RS232CRX	I	PC serial signal
33	TRAY OUT	O	TRAY out control output to the Motor Driver (IC712)
34	P10	—	Not used (open)
35	DRV ON	O	Driver mute output to the Motor Driver (IC712)
36	SP ON	O	Spindle mute output to the Motor Driver (IC712)
37	P13	—	Not used (open)
38	XLDON	O	LD ON/OFF output to the Motor Driver (IC712)
39	TRMP	O	Table control (+Clockwise) output to the TMD (IC710)
40	TRMM	O	Table control (-Counterclock) output to the TMD (IC710)
41	P17	—	Not used (open)
42	AVSS	—	Ground terminal
43	DIAO	I	Test Mode input
44	P96	—	Ground terminal
45 to 50	P47 to P42	—	Ground terminal
51	MODEL	I	Model check (L:1Hi,Mi:5Es,H:5 Hi)
52	JIT	I	Waltz jetter select
53	VREF	I	Reference voltage
54	AVCC	—	Power supply terminal (+3.3V)
55	MD0	I	Moving mode control 0
56	MD1	I	Moving mode control 1
57	OSC2	—	Not used (open)
58	OSC1	—	Ground terminal
59	XRST	O	System reset
60	XNMI	I	NMI input (fixed at "H")
61	XSTBY	I	Standby input (fixed at "H")
62	VCC	—	Power supply terminal (+3.3V)
63	XTAL	—	Not used (open)
64	VSS1	—	Ground terminal
65	EXTAL	I	External clock input

Pin No.	Pin Name	I/O	Description
66	FEW	I	Flash writing Enable
67	MD2	I	Moving mode control 2
68	PF7	—	Not used (open)
69	AS	—	Not used (open)
70	XDR	O	Reed sycle signal
71	XWR	O	Write sycle signal
72	XWRST	O	Waltz reset signal output
73	XWAIT	I	Bus sycle wait signal input
74	SMUTE	O	Waltz smute signal output
75	EPR/B	I	Read/Busy signal input from the EEPROM (IC702)
76	XEPCE	O	XCS signal output to the EEPROM (IC702)
77	XEWC	O	XWC signal output to the EEPROM (IC702)
78	P32	O	Not used (open)
79	EEPS0	O	Communication signal to the EEPROM (IC702)
80	EEPS1	I	Communication signal from the EEPROM (IC702)
81	EEPSC	O	Communication signal to the EEPROM (IC702)
82	P36	—	Not used (open)
83	IFS0	O	Communication signal to the IS CON (IC801)
84	IFS1	I	Communication signal from the IS CON (IC801)
85	IFSCK	O	Communication signal to the IS CON (IC801)
86	P74	—	Not used (open)
87	XCS	O	WALTZ chip select
88	P72	—	Not used (open)
89	P71	—	Not used (open)
90	P70	—	Not used (open)
91	XIFINT	I	ACK input signal from the IS CON (IC801)
92	XINTO	I	WALTZ input from the Digital Servo Processor (IC706)
93	PG2	—	Ground terminal
94	MZR	I	ZEROR input signal from DAC (IC200)
95	MZL	I	ZEROL input signal from DAC (IC200)
96	XIFCS	O	Chip select to the IS CON (IC801)
97	R MUTE	O	Rch mute signal output
98	L MUTE	O	Lch mute signal output
99	INIT DAC	O	DAC int output
100	M/2	O	Mch mute control output (surr/Cntr/Sw)

SECTION 5 EXPLODED VIEWS

NOTE:

- -XX and -X mean standardized parts, so they may have some difference from the original one.
- Items marked “*” are not stocked since they are seldom required for routine service. Some delay should be anticipated when ordering these items.

- The mechanical parts with no reference number in the exploded views are not supplied.
- Abbreviation
CND : Canadian model

The components identified by mark \triangle or dotted line with mark \triangle are critical for safety. Replace only with part number specified.

Les composants identifiés par une marque \triangle sont critiques pour la sécurité. Ne les remplacer que par une pièce portant le numéro spécifié.

5-1. MAIN SECTION

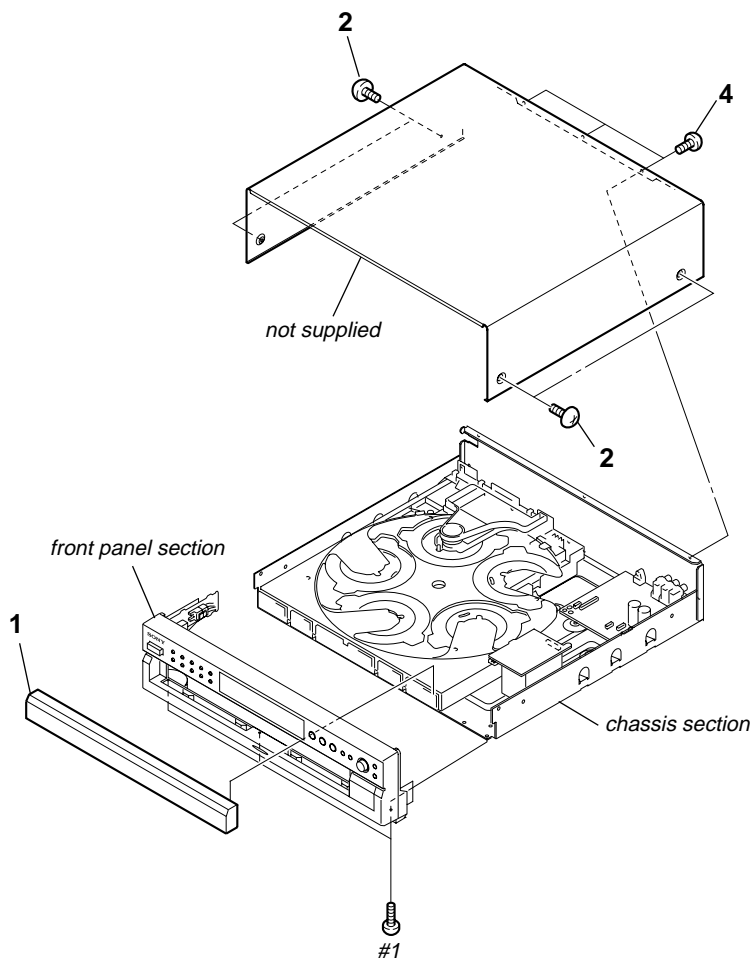

Ref. No.	Part No.	Description	Remark	Ref. No.	Part No.	Description	Remark
1	X-4956-436-1	PANEL ASSY, LOADING		4	4-951-620-01	SCREW (2.6X8), +BVTP	
2	3-363-099-02	SCREW (CASE 3 TP2)		#1	7-685-872-09	SCREW +BVTT 3X8	

5-2. FRONT PANEL SECTION

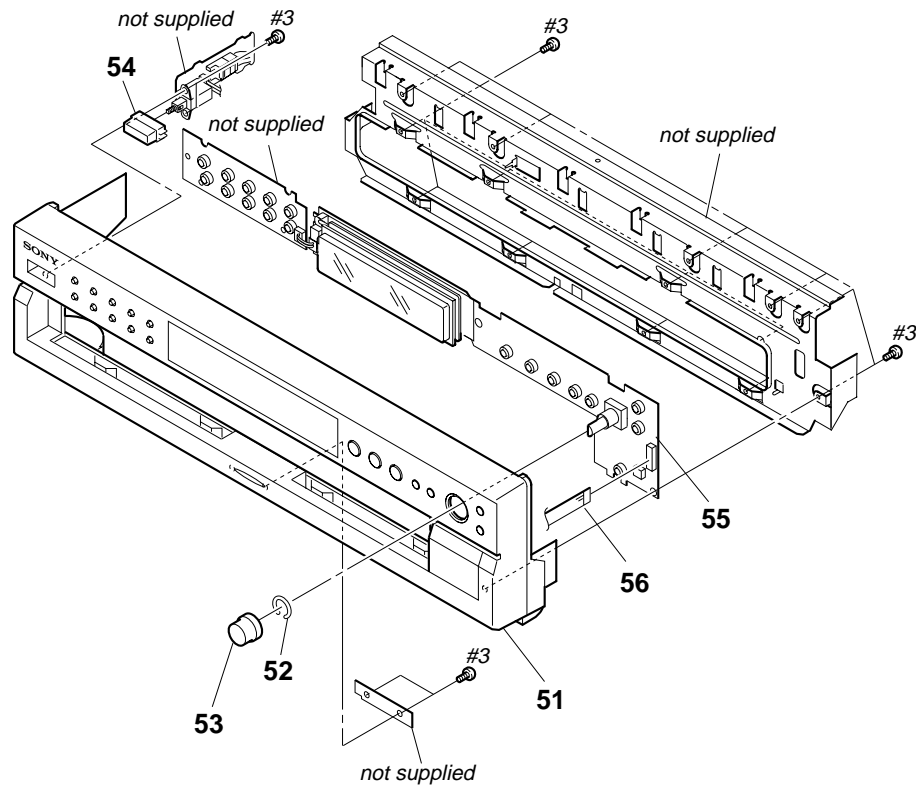

Ref. No.	Part No.	Description	Remark	Ref. No.	Part No.	Description	Remark
51	X-4956-434-1	PANEL ASSY, FRONT (US,CND)		54	4-255-244-01	BUTTON, POWER	
51	X-4956-435-1	PANEL ASSY, FRONT (AEP,UK)		55	A-4752-651-A	DISPLAY BOARD, COMPLETE	
52	3-354-981-11	SPRING (SUS), RING		56	1-828-334-11	WIRE (FLAT TYPE) (13 CORE)	
53	4-232-622-01	KNOB (AMS)		#3	7-685-646-79	SCREW +BVTP 3X8 TYPE2 IT-3	

5-3. CHASSIS SECTION

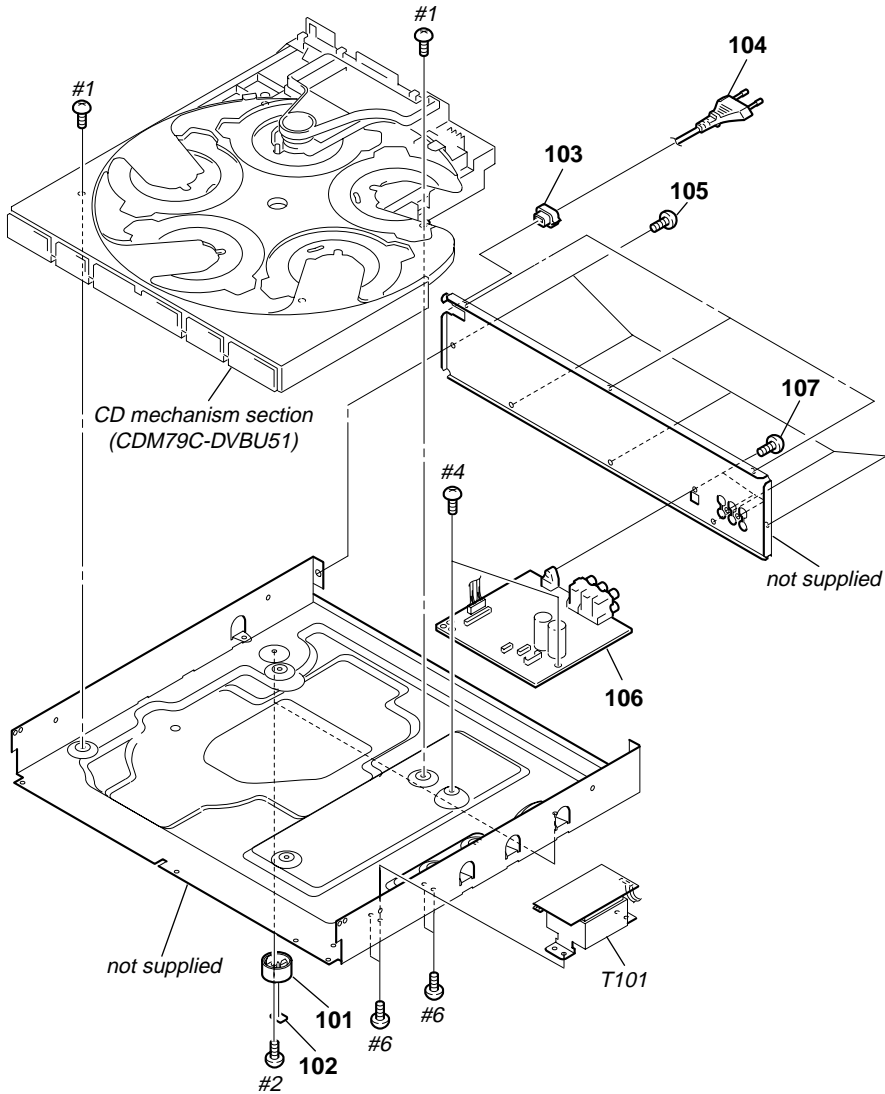

Ref. No.	Part No.	Description	Remark	Ref. No.	Part No.	Description	Remark
101	X-2022-049-1	FOOT ASSY		107	4-951-620-01	SCREW (2.6X8), +BVTP	
102	4-977-358-01	CUSHION		△ T101	1-443-286-11	TRANSFORMER, POWER (US,CND)	
* 103	3-703-244-00	BUSHING (2104), CORD		△ T101	1-443-287-11	TRANSFORMER, POWER (AEP,UK)	
△ 104	1-777-071-43	CORD, POWER (AEP,UK)		#1	7-685-872-09	SCREW +BVTT 3X8	
△ 104	1-783-531-32	CORD, POWER (US,CND)		#2	7-685-535-19	SCREW +BTP 2.6X10 TYPE2 N-S	
105	3-704-515-32	SCREW (BV/RING)		#4	7-682-544-04	SCREW +P 3X3	
106	A-4752-598-A	MAIN BOARD, COMPLETE		#6	7-685-534-19	SCREW +BTP 2.6X8 TYPE2 N-S	

<p>The components identified by mark △ or dotted line with mark △ are critical for safety. Replace only with part number specified.</p>	<p>Les composants identifiés par une marque △ sont critiques pour la sécurité. Ne les remplacer que par une pièce portant le numéro spécifié.</p>
---	---

5-4. CD MECHANISM SECTION (1)
(CDM79C-DVBU51)

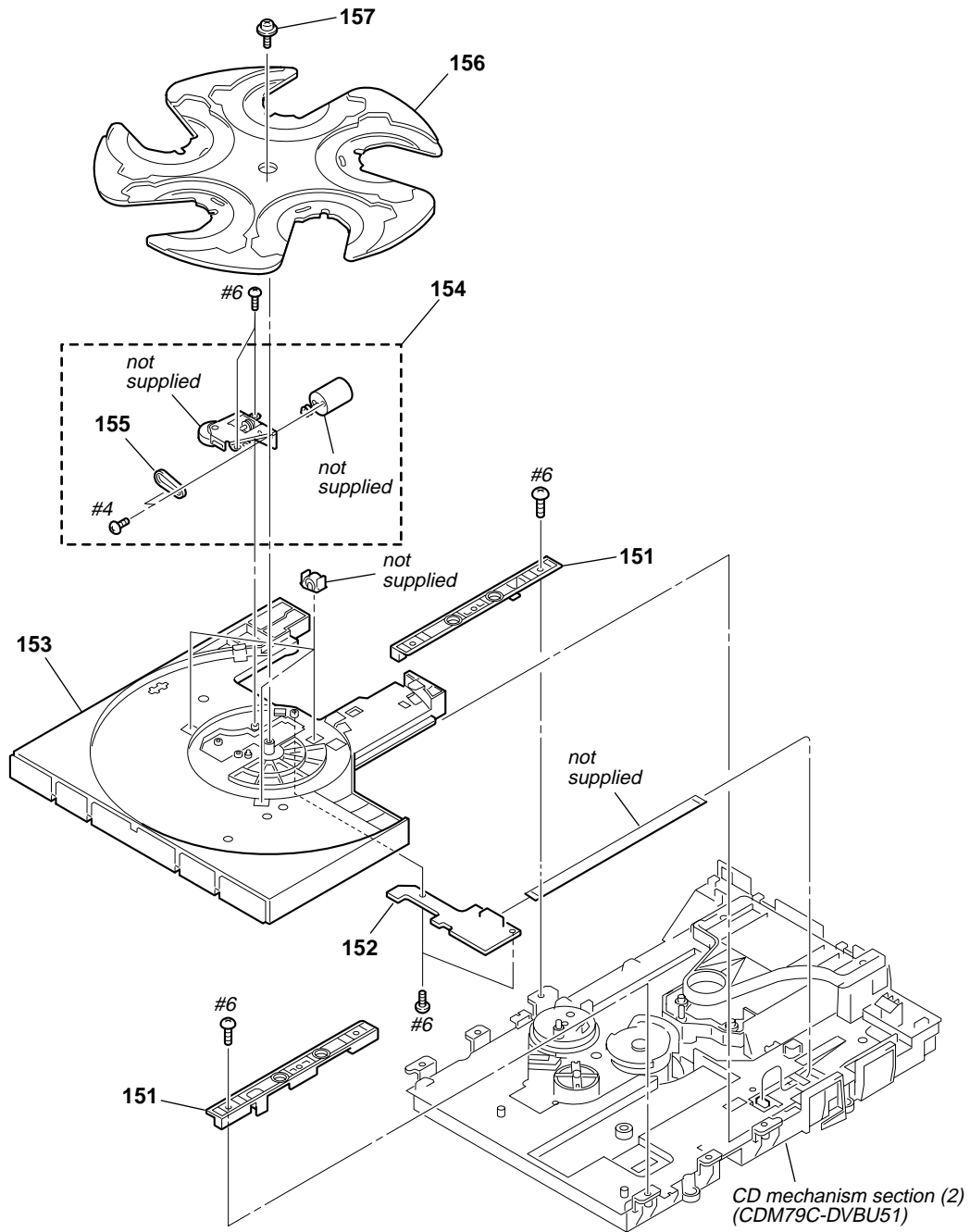

Ref. No.	Part No.	Description	Remark	Ref. No.	Part No.	Description	Remark
151	3-074-737-01	PLATE (GUIDE)		156	3-074-717-01	TRAY	
152	A-6060-642-A	SE-130 BOARD, COMPLETE		157	4-218-252-52	SCREW (+PTPWH M2.6), FLOATING	
153	3-074-716-01	TABLE		#4	7-682-544-04	SCREW +P 3X3	
154	A-6060-640-A	UNIT ASSY, TD		#6	7-685-534-19	SCREW +BTP 2.6X8 TYPE2 N-S	
155	3-074-725-01	BELT, TD					

5-5. CD MECHANISM SECTION (2)
(CDM79C-DVBU51)

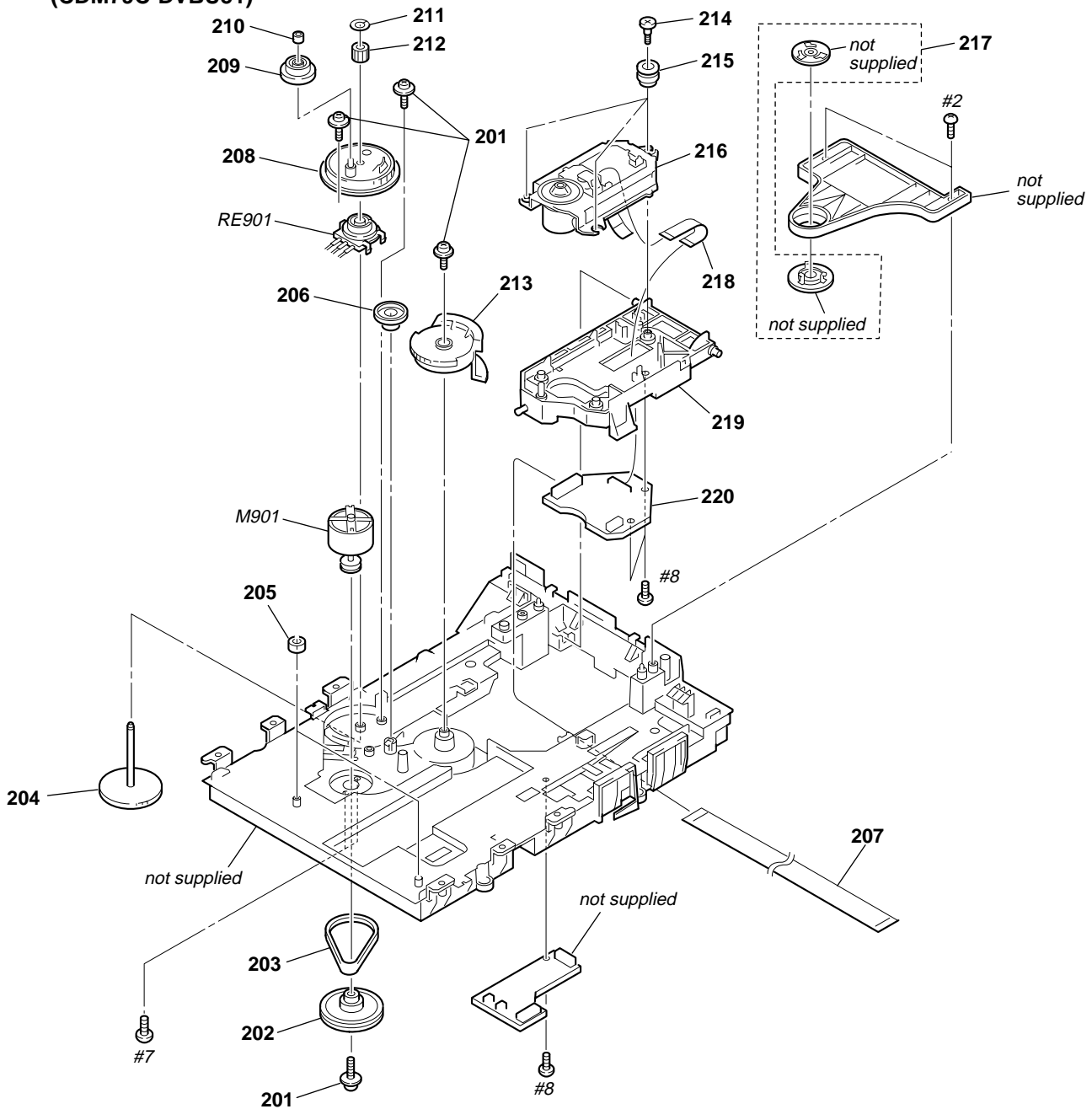

Ref. No.	Part No.	Description	Remark	Ref. No.	Part No.	Description	Remark
201	4-218-252-52	SCREW (+PTPWH M2.6), FLOATING		214	4-981-923-01	SCREW (M), STEP	
202	3-074-744-01	GEAR (LOADING A)		215	3-053-847-31	INSULATOR	
203	3-074-745-01	BELT (LOADING)		△216	A-1067-676-A	DEVICE, OPTICAL (DBU-3)	
204	3-074-742-01	GEAR (SHAFT)		217	A-4736-882-A	CHUCK ASSY	
205	4-951-619-01	CUSHION (A)		218	1-824-106-12	CABLE, FLEXIBLE FLAT (24 CORE)	
206	3-074-735-01	GEAR (IDLER)		219	X-4955-252-3	HOLDER (BU) ASSY	
207	1-829-172-11	WIRE (FLAT TYPE) (31 CORE)		220	A-4750-527-A	RF BOARD, COMPLETE	
208	3-074-741-01	GEAR (LOADING B)		M901	1-541-632-12	MOTOR, DC	
209	3-074-738-01	GEAR (SWING)		RE901	1-418-746-11	ENCODER, ROTARY	
210	3-074-739-01	COLLAR (SWING)		#2	7-685-535-19	SCREW +BTP 2.6X10 TYPE2 N-S	
211	3-016-533-01	WASHER (FR), STOPPER		#7	7-621-259-25	SCREW +P 2.6X4	
212	3-074-740-01	GEAR (LOADING C)		#8	7-685-534-19	SCREW +BTP 2.6X8 TYPE2 N-S	
213	3-074-736-01	GEAR (CHUCK)					

<p>The components identified by mark △ or dotted line with mark △ are critical for safety. Replace only with part number specified.</p>	<p>Les composants identifiés par une marque △ sont critiques pour la sécurité. Ne les remplacer que par une pièce portant le numéro spécifié.</p>
---	---

SECTION 6 ELECTRICAL PARTS LIST

DISPLAY

NOTE:

- Due to standardization, replacements in the parts list may be different from the parts specified in the diagrams or the components used on the set.
- -XX and -X mean standardized parts, so they may have some difference from the original one.
- Items marked "*" are not stocked since they are seldom required for routine service. Some delay should be anticipated when ordering these items.
- CAPACITORS
uF: μF

- RESISTORS
All resistors are in ohms.
METAL: Metal-film resistor.
METAL OXIDE: Metal oxide-film resistor.
F: nonflammable
- COILS
uH: μH
- SEMICONDUCTORS
In each case, u: μ, for example:
uA. . : μA. . uPA. . : μPA. .
uPB. . : μPB. . uPC. . : μPC. .
uPD. . : μPD. .
- Abbreviation
CND : Canadian model

When indicating parts by reference number, please include the board name.

The components identified by mark Δ or dotted line with mark Δ are critical for safety. Replace only with part number specified.

Les composants identifiés par une marque Δ sont critiques pour la sécurité. Ne les remplacer que par une pièce portant le numéro spécifié.

- Accessories are given in the last of this parts list.

Ref. No.	Part No.	Description	Remark	Ref. No.	Part No.	Description	Remark	
	A-4752-651-A	DISPLAY BOARD, COMPLETE *****				< TRANSISTOR >		
	4-949-935-41	CUSHION (FL)		Q821	8-729-027-43	TRANSISTOR	DTC114EKA-T146	
		< CAPACITOR >		Q822	8-729-027-43	TRANSISTOR	DTC114EKA-T146	
C801	1-124-584-00	ELECT	100uF 20%	6.3V	Q823	8-729-027-43	TRANSISTOR	DTC114EKA-T146
C802	1-164-156-11	CERAMIC CHIP	0.1uF	25V	Q824	8-729-027-43	TRANSISTOR	DTC114EKA-T146
C803	1-164-156-11	CERAMIC CHIP	0.1uF	25V	Q825	8-729-027-43	TRANSISTOR	DTC114EKA-T146
C804	1-164-156-11	CERAMIC CHIP	0.1uF	25V			< RESISTOR >	
C805	1-164-156-11	CERAMIC CHIP	0.1uF	25V	R805	1-216-833-11	METAL CHIP	10K 5% 1/10W
C806	1-165-319-11	CERAMIC CHIP	0.1uF	50V	R817	1-216-833-11	METAL CHIP	10K 5% 1/10W
C811	1-162-964-11	CERAMIC CHIP	0.001uF 10%	50V	R818	1-216-833-11	METAL CHIP	10K 5% 1/10W
C812	1-162-964-11	CERAMIC CHIP	0.001uF 10%	50V	R819	1-216-833-11	METAL CHIP	10K 5% 1/10W
C813	1-162-964-11	CERAMIC CHIP	0.001uF 10%	50V	R820	1-216-833-11	METAL CHIP	10K 5% 1/10W
C816	1-162-964-11	CERAMIC CHIP	0.001uF 10%	50V	R821	1-216-845-11	METAL CHIP	100K 5% 1/10W
C817	1-162-970-11	CERAMIC CHIP	0.01uF 10%	25V	R822	1-216-845-11	METAL CHIP	100K 5% 1/10W
C818	1-162-970-11	CERAMIC CHIP	0.01uF 10%	25V	R823	1-216-845-11	METAL CHIP	100K 5% 1/10W
C819	1-162-970-11	CERAMIC CHIP	0.01uF 10%	25V	R824	1-216-845-11	METAL CHIP	100K 5% 1/10W
C820	1-162-970-11	CERAMIC CHIP	0.01uF 10%	25V	R825	1-216-845-11	METAL CHIP	100K 5% 1/10W
C821	1-162-964-11	CERAMIC CHIP	0.001uF 10%	50V	R826	1-216-833-11	METAL CHIP	10K 5% 1/10W
C822	1-162-964-11	CERAMIC CHIP	0.001uF 10%	50V	R831	1-216-805-11	METAL CHIP	47 5% 1/10W
C823	1-162-964-11	CERAMIC CHIP	0.001uF 10%	50V	R832	1-216-809-11	METAL CHIP	100 5% 1/10W
C824	1-162-964-11	CERAMIC CHIP	0.001uF 10%	50V	R841	1-216-821-11	METAL CHIP	1K 5% 1/10W
C825	1-162-964-11	CERAMIC CHIP	0.001uF 10%	50V	R842	1-216-825-11	METAL CHIP	2.2K 5% 1/10W
C827	1-165-319-11	CERAMIC CHIP	0.1uF	50V	R843	1-216-825-11	METAL CHIP	2.2K 5% 1/10W
C829	1-165-319-11	CERAMIC CHIP	0.1uF	50V	R844	1-216-829-11	METAL CHIP	4.7K 5% 1/10W
C831	1-124-589-11	ELECT	47uF 20%	6.3V	R845	1-216-833-11	METAL CHIP	10K 5% 1/10W
C832	1-162-970-11	CERAMIC CHIP	0.01uF 10%	25V	R851	1-216-821-11	METAL CHIP	1K 5% 1/10W
		< CONNECTOR >		R852	1-216-825-11	METAL CHIP	2.2K 5% 1/10W	
CN801	1-779-281-11	CONNECTOR, FFC (LIF (NON-ZIF)) 13P		R853	1-216-825-11	METAL CHIP	2.2K 5% 1/10W	
		< FERRITE BEAD >		R854	1-216-829-11	METAL CHIP	4.7K 5% 1/10W	
FB801	1-414-595-11	INDUCTOR, FERRITE BEAD		R856	1-216-833-11	METAL CHIP	10K 5% 1/10W	
		< FLUORESCENT INDICATOR TUBE >		R857	1-216-833-11	METAL CHIP	10K 5% 1/10W	
FL801	1-518-992-11	INDICATOR TUBE, FLUORESCENT		R858	1-216-808-11	METAL CHIP	82 5% 1/10W	
		< IC >				< SWITCH >		
IC801	6-804-318-01	IC uPD780232GC-706-8BT-A		S841	1-762-875-21	SWITCH, KEYBOARD (■)		
IC802	8-759-826-33	IC NJL73H400A (■)		S842	1-762-875-21	SWITCH, KEYBOARD (▷)		
				S843	1-762-875-21	SWITCH, KEYBOARD (■)		
				S844	1-762-875-21	SWITCH, KEYBOARD (◀◀)		
				S845	1-762-875-21	SWITCH, KEYBOARD (▶▶)		
				S851	1-762-875-21	SWITCH, KEYBOARD (≡)		
				S852	1-762-875-21	SWITCH, KEYBOARD (EX-CHANGE)		

SCD-CE595

DISPLAY **KEY** **LED** **MAIN**

Ref. No.	Part No.	Description	Remark
S853	1-762-875-21	SWITCH, KEYBOARD (DISC SKIP)	
S855	1-478-268-11	ENCODER, ROTARY (◀◀ AMS ▶▶)(PUSH ENTER)	
< VIBRATOR >			
X801	1-795-058-21	VIBRATOR, CERAMIC 5MHz	

	1-862-173-11	KEY BOARD *****	
< CONNECTOR >			
CN813	1-506-468-11	PIN, CONNECTOR 3P	
< RESISTOR >			
R861	1-216-821-11	METAL CHIP 1K 5% 1/10W	
R862	1-216-825-11	METAL CHIP 2.2K 5% 1/10W	
R863	1-216-825-11	METAL CHIP 2.2K 5% 1/10W	
R864	1-216-829-11	METAL CHIP 4.7K 5% 1/10W	
R871	1-216-821-11	METAL CHIP 1K 5% 1/10W	
R872	1-216-825-11	METAL CHIP 2.2K 5% 1/10W	
R873	1-216-825-11	METAL CHIP 2.2K 5% 1/10W	
R874	1-216-829-11	METAL CHIP 4.7K 5% 1/10W	
< SWITCH >			
S861	1-762-875-21	SWITCH, KEYBOARD (MENU)	
S862	1-762-875-21	SWITCH, KEYBOARD (SA-CD/CD)	
S863	1-762-875-21	SWITCH, KEYBOARD (MULTI/2CH)	
S864	1-762-875-21	SWITCH, KEYBOARD (PLAY MODE)	
S865	1-762-875-21	SWITCH, KEYBOARD (TIME/TEXT)	
S871	1-762-875-21	SWITCH, KEYBOARD (DISC 1)	
S872	1-762-875-21	SWITCH, KEYBOARD (DISC 2)	
S873	1-762-875-21	SWITCH, KEYBOARD (DISC 3)	
S874	1-762-875-21	SWITCH, KEYBOARD (DISC 4)	
S875	1-762-875-21	SWITCH, KEYBOARD (DISC 5)	

	1-862-174-11	LED BOARD *****	
< CAPACITOR >			
C833	1-164-156-11	CERAMIC CHIP 0.1uF 25V	
< CONNECTOR >			
CN814	1-506-481-11	PIN, CONNECTOR 2P	
< DIODE >			
D801	6-500-647-01	DIODE SEL5E20C-STP15	
< RESISTOR >			
R834	1-216-833-11	METAL CHIP 10K 5% 1/10W	

	A-4752-598-A	MAIN BOARD, COMPLETE *****	
< CAPACITOR >			
C201	1-126-916-11	ELECT 1000uF 20% 6.3V	

Ref. No.	Part No.	Description	Remark
C202	1-126-205-11	ELECT CHIP 47uF 20% 6.3V	
C206	1-115-156-11	CERAMIC CHIP 1uF 10V	
C208	1-115-156-11	CERAMIC CHIP 1uF 10V	
C212	1-128-991-21	ELECT CHIP 10uF 20% 50V	
C236	1-115-156-11	CERAMIC CHIP 1uF 10V	
C238	1-115-156-11	CERAMIC CHIP 1uF 10V	
C242	1-128-991-21	ELECT CHIP 10uF 20% 50V	
C266	1-115-156-11	CERAMIC CHIP 1uF 10V	
C268	1-115-156-11	CERAMIC CHIP 1uF 10V	
C272	1-128-991-21	ELECT CHIP 10uF 20% 50V	
C281	1-162-966-11	CERAMIC CHIP 0.0022uF 10% 50V	
C302	1-164-156-11	CERAMIC CHIP 0.1uF 25V	
C303	1-164-156-11	CERAMIC CHIP 0.1uF 25V	
C305	1-164-156-11	CERAMIC CHIP 0.1uF 25V	
C321	1-162-917-11	CERAMIC CHIP 15PF 5% 50V	
C322	1-162-917-11	CERAMIC CHIP 15PF 5% 50V	
C324	1-115-156-11	CERAMIC CHIP 1uF 10V	
C325	1-126-206-11	ELECT CHIP 100uF 20% 6.3V	
C331	1-164-156-11	CERAMIC CHIP 0.1uF 25V	
C351	1-164-156-11	CERAMIC CHIP 0.1uF 25V	
C362	1-164-156-11	CERAMIC CHIP 0.1uF 25V	
C364	1-164-156-11	CERAMIC CHIP 0.1uF 25V	
C366	1-164-156-11	CERAMIC CHIP 0.1uF 25V	
C402	1-115-416-11	CERAMIC CHIP 0.001uF 5% 25V	
C403	1-164-217-11	CERAMIC CHIP 150PF 5% 50V	
C404	1-115-156-11	CERAMIC CHIP 1uF 10V	
C405	1-107-826-11	CERAMIC CHIP 0.1uF 10% 16V	
C406	1-128-992-21	ELECT CHIP 47uF 20% 25V	
C432	1-115-416-11	CERAMIC CHIP 0.001uF 5% 25V	
C433	1-164-217-11	CERAMIC CHIP 150PF 5% 50V	
C434	1-115-156-11	CERAMIC CHIP 1uF 10V	
C435	1-107-826-11	CERAMIC CHIP 0.1uF 10% 16V	
C436	1-128-992-21	ELECT CHIP 47uF 20% 25V	
C462	1-115-416-11	CERAMIC CHIP 0.001uF 5% 25V	
C463	1-164-217-11	CERAMIC CHIP 150PF 5% 50V	
C464	1-115-156-11	CERAMIC CHIP 1uF 10V	
C465	1-107-826-11	CERAMIC CHIP 0.1uF 10% 16V	
C466	1-128-992-21	ELECT CHIP 47uF 20% 25V	
C502	1-115-416-11	CERAMIC CHIP 0.001uF 5% 25V	
C503	1-164-217-11	CERAMIC CHIP 150PF 5% 50V	
C504	1-115-156-11	CERAMIC CHIP 1uF 10V	
C505	1-107-826-11	CERAMIC CHIP 0.1uF 10% 16V	
C506	1-128-992-21	ELECT CHIP 47uF 20% 25V	
C532	1-115-416-11	CERAMIC CHIP 0.001uF 5% 25V	
C533	1-164-217-11	CERAMIC CHIP 150PF 5% 50V	
C534	1-115-156-11	CERAMIC CHIP 1uF 10V	
C535	1-107-826-11	CERAMIC CHIP 0.1uF 10% 16V	
C536	1-128-992-21	ELECT CHIP 47uF 20% 25V	
C562	1-115-416-11	CERAMIC CHIP 0.001uF 5% 25V	
C563	1-164-217-11	CERAMIC CHIP 150PF 5% 50V	
C564	1-115-156-11	CERAMIC CHIP 1uF 10V	
C565	1-107-826-11	CERAMIC CHIP 0.1uF 10% 16V	
C566	1-128-992-21	ELECT CHIP 47uF 20% 25V	
C701	1-164-156-11	CERAMIC CHIP 0.1uF 25V	
C702	1-125-837-91	CERAMIC CHIP 1uF 10% 6.3V	
C703	1-164-156-11	CERAMIC CHIP 0.1uF 25V	
C704	1-164-156-11	CERAMIC CHIP 0.1uF 25V	
C705	1-164-156-11	CERAMIC CHIP 0.1uF 25V	

Ref. No.	Part No.	Description	Remark			Ref. No.	Part No.	Description	Remark		
C706	1-164-156-11	CERAMIC CHIP	0.1uF		25V	C778	1-164-156-11	CERAMIC CHIP	0.1uF		25V
C709	1-126-246-11	ELECT CHIP	220uF	20%	4V	C779	1-164-156-11	CERAMIC CHIP	0.1uF		25V
C711	1-164-156-11	CERAMIC CHIP	0.1uF		25V	C780	1-164-156-11	CERAMIC CHIP	0.1uF		25V
C712	1-164-156-11	CERAMIC CHIP	0.1uF		25V	C781	1-164-156-11	CERAMIC CHIP	0.1uF		25V
C713	1-117-681-11	ELECT CHIP	100uF	20%	16V	C782	1-164-156-11	CERAMIC CHIP	0.1uF		25V
C714	1-126-246-11	ELECT CHIP	220uF	20%	4V	C783	1-117-681-11	ELECT CHIP	100uF	20%	16V
C715	1-164-156-11	CERAMIC CHIP	0.1uF		25V	C785	1-126-246-11	ELECT CHIP	220uF	20%	4V
C716	1-117-681-11	ELECT CHIP	100uF	20%	16V	C787	1-164-156-11	CERAMIC CHIP	0.1uF		25V
C721	1-164-156-11	CERAMIC CHIP	0.1uF		25V	C788	1-164-156-11	CERAMIC CHIP	0.1uF		25V
C722	1-107-826-11	CERAMIC CHIP	0.1uF	10%	16V	C789	1-164-156-11	CERAMIC CHIP	0.1uF		25V
C723	1-125-837-91	CERAMIC CHIP	1uF	10%	6.3V	C791	1-128-992-21	ELECT CHIP	47uF	20%	25V
C726	1-162-964-11	CERAMIC CHIP	0.001uF	10%	50V	C793	1-164-156-11	CERAMIC CHIP	0.1uF		25V
C727	1-162-968-11	CERAMIC CHIP	0.0047uF	10%	50V	C794	1-164-156-11	CERAMIC CHIP	0.1uF		25V
C729	1-162-964-11	CERAMIC CHIP	0.001uF	10%	50V	C795	1-117-681-11	ELECT CHIP	100uF	20%	16V
C730	1-162-968-11	CERAMIC CHIP	0.0047uF	10%	50V	C796	1-117-681-11	ELECT CHIP	100uF	20%	16V
C731	1-162-968-11	CERAMIC CHIP	0.0047uF	10%	50V	C799	1-164-156-11	CERAMIC CHIP	0.1uF		25V
C733	1-165-176-11	CERAMIC CHIP	0.047uF	10%	16V	C800	1-164-156-11	CERAMIC CHIP	0.1uF		25V
C734	1-107-826-11	CERAMIC CHIP	0.1uF	10%	16V	C804	1-164-156-11	CERAMIC CHIP	0.1uF		25V
C736	1-164-156-11	CERAMIC CHIP	0.1uF		25V	C806	1-107-826-11	CERAMIC CHIP	0.1uF	10%	16V
C737	1-164-156-11	CERAMIC CHIP	0.1uF		25V	C808	1-107-726-91	CERAMIC CHIP	0.01uF	10%	16V
C738	1-164-156-11	CERAMIC CHIP	0.1uF		25V	C809	1-164-677-11	CERAMIC CHIP	0.033uF	10%	16V
C739	1-164-156-11	CERAMIC CHIP	0.1uF		25V	C813	1-164-677-11	CERAMIC CHIP	0.033uF	10%	16V
C740	1-164-156-11	CERAMIC CHIP	0.1uF		25V	C814	1-115-467-11	CERAMIC CHIP	0.22uF	10%	10V
C741	1-164-156-11	CERAMIC CHIP	0.1uF		25V	C815	1-164-245-11	CERAMIC CHIP	0.015uF	10%	25V
C742	1-164-156-11	CERAMIC CHIP	0.1uF		25V	C816	1-162-964-11	CERAMIC CHIP	0.001uF	10%	50V
C743	1-164-156-11	CERAMIC CHIP	0.1uF		25V	C817	1-162-964-11	CERAMIC CHIP	0.001uF	10%	50V
C744	1-115-156-11	CERAMIC CHIP	1uF		10V	C819	1-115-156-11	CERAMIC CHIP	1uF		10V
C745	1-107-826-11	CERAMIC CHIP	0.1uF	10%	16V	C820	1-164-816-11	CERAMIC CHIP	220PF	2%	50V
C746	1-164-156-11	CERAMIC CHIP	0.1uF		25V	C821	1-162-927-11	CERAMIC CHIP	100PF	5%	50V
C748	1-164-156-11	CERAMIC CHIP	0.1uF		25V	C822	1-164-816-11	CERAMIC CHIP	220PF	2%	50V
C749	1-107-826-11	CERAMIC CHIP	0.1uF	10%	16V	C825	1-162-965-11	CERAMIC CHIP	0.0015uF	10%	50V
C750	1-115-156-11	CERAMIC CHIP	1uF		10V	C828	1-110-563-11	CERAMIC CHIP	0.068uF	10%	16V
C751	1-162-927-11	CERAMIC CHIP	100PF	5%	50V	C829	1-110-563-11	CERAMIC CHIP	0.068uF	10%	16V
C752	1-164-156-11	CERAMIC CHIP	0.1uF		25V	C830	1-162-927-11	CERAMIC CHIP	100PF	5%	50V
C753	1-164-156-11	CERAMIC CHIP	0.1uF		25V	C832	1-162-968-11	CERAMIC CHIP	0.0047uF	10%	50V
C754	1-126-246-11	ELECT CHIP	220uF	20%	4V	C901	1-162-970-11	CERAMIC CHIP	0.01uF	10%	25V
C755	1-164-156-11	CERAMIC CHIP	0.1uF		25V	C910	1-162-964-11	CERAMIC CHIP	0.001uF	10%	50V
C756	1-164-156-11	CERAMIC CHIP	0.1uF		25V	C920	1-162-970-11	CERAMIC CHIP	0.01uF	10%	25V
C757	1-164-156-11	CERAMIC CHIP	0.1uF		25V	C921	1-128-546-11	ELECT	10000uF	20%	10V
C758	1-164-156-11	CERAMIC CHIP	0.1uF		25V	C923	1-164-156-11	CERAMIC CHIP	0.1uF		25V
C759	1-164-156-11	CERAMIC CHIP	0.1uF		25V	C924	1-126-925-91	ELECT	470uF	20%	10V
C760	1-164-156-11	CERAMIC CHIP	0.1uF		25V	C931	1-126-939-11	ELECT	10000uF	20%	16V
C761	1-164-156-11	CERAMIC CHIP	0.1uF		25V	C932	1-126-951-11	ELECT	470uF	20%	35V
C762	1-164-156-11	CERAMIC CHIP	0.1uF		25V	C933	1-164-156-11	CERAMIC CHIP	0.1uF		25V
C763	1-164-156-11	CERAMIC CHIP	0.1uF		25V	C934	1-126-935-11	ELECT	470uF	20%	16V
C764	1-164-156-11	CERAMIC CHIP	0.1uF		25V	C935	1-126-767-11	ELECT	1000uF	20%	16V
C765	1-164-156-11	CERAMIC CHIP	0.1uF		25V	C953	1-164-156-11	CERAMIC CHIP	0.1uF		25V
C766	1-164-156-11	CERAMIC CHIP	0.1uF		25V	C954	1-126-925-91	ELECT	470uF	20%	10V
C767	1-164-156-11	CERAMIC CHIP	0.1uF		25V	C961	1-128-991-21	ELECT CHIP	10uF	20%	50V
C768	1-164-156-11	CERAMIC CHIP	0.1uF		25V	C962	1-164-156-11	CERAMIC CHIP	0.1uF		25V
C769	1-164-156-11	CERAMIC CHIP	0.1uF		25V	C970	1-162-970-11	CERAMIC CHIP	0.01uF	10%	25V
C770	1-164-156-11	CERAMIC CHIP	0.1uF		25V	C971	1-128-552-51	ELECT	47uF	20%	63V
C771	1-164-156-11	CERAMIC CHIP	0.1uF		25V	C972	1-128-991-21	ELECT CHIP	10uF	20%	50V
C772	1-164-156-11	CERAMIC CHIP	0.1uF		25V	C973	1-126-395-11	ELECT CHIP	22uF	20%	16V
C775	1-164-156-11	CERAMIC CHIP	0.1uF		25V	< CONNECTOR >					
C776	1-164-156-11	CERAMIC CHIP	0.1uF		25V	CN701	1-784-368-11	CONNECTOR, FFC/FPC 9P			
C777	1-162-915-11	CERAMIC CHIP	10PF	0.5PF	50V	CN702	1-784-387-11	CONNECTOR, FFC/FPC 31P			

MAIN

Ref. No.	Part No.	Description	Remark	Ref. No.	Part No.	Description	Remark
CN703	1-793-989-21	CONNECTOR, FFC/FPC 13P				< JACK >	
CN901	1-784-924-11	PIN, CONNECTOR 8P					
		< DIODE >					
D321	8-719-027-76	DIODE 1SS357-TPH3					
D509	8-719-941-09	DIODE DAP202UT106					
D511	8-719-941-09	DIODE DAP202UT106					
D703	8-719-069-54	DIODE UDZSTE-175.1B					
D921	8-719-053-18	DIODE 1SR154-400TE-25					
D922	8-719-053-18	DIODE 1SR154-400TE-25					
D923	8-719-053-18	DIODE 1SR154-400TE-25					
D924	8-719-053-18	DIODE 1SR154-400TE-25					
D931	8-719-053-18	DIODE 1SR154-400TE-25					
D932	8-719-053-18	DIODE 1SR154-400TE-25					
D933	8-719-053-18	DIODE 1SR154-400TE-25					
D934	8-719-053-18	DIODE 1SR154-400TE-25					
D936	8-719-053-18	DIODE 1SR154-400TE-25					
D937	8-719-053-18	DIODE 1SR154-400TE-25					
D960	8-719-941-86	DIODE DAN202UT106					
D961	8-719-941-86	DIODE DAN202UT106					
D963	6-500-696-01	DIODE UDZSTE-173.0B					
D971	8-719-053-18	DIODE 1SR154-400TE-25					
D972	8-719-083-87	DIODE UDZS-TE17-33B					
D973	8-719-069-60	DIODE UDZSTE-179.1B					
		< GROUND TERMINAL BOARD >					
ETP910	1-537-771-21	TERMINAL BOARD, GROUND					
		< FERRITE BEAD >					
FB201	1-500-283-11	INDUCTOR, FERRITE BEAD					
FB703	1-414-595-11	INDUCTOR, FERRITE BEAD					
FB710	1-414-595-11	INDUCTOR, FERRITE BEAD					
		< FILTER >					
FL606	1-234-177-21	FILTER, CHIP EMI					
		< IC >					
IC200	6-703-420-01	IC DSD1751DBQR					
IC230	6-703-420-01	IC DSD1751DBQR					
IC260	6-703-420-01	IC DSD1751DBQR					
IC320	8-759-549-25	IC SN74LVU04APWR					
IC330	6-600-012-01	IC TOTX141L					
IC400	8-759-710-97	IC NJM4565M (TE2)					
IC430	8-759-710-97	IC NJM4565M (TE2)					
IC460	8-759-710-97	IC NJM4565M (TE2)					
IC701	8-759-636-64	IC M51957BFP-600C					
* IC702	6-703-671-01	IC BR9040F-WE2					
IC703	6-700-398-01	IC uPC2918T-E1					
IC705	6-804-317-01	IC HD6432238RN51TEV					
IC706	8-752-420-59	IC CXD2754Q					
IC708	6-702-336-01	IC MSM56V16160F-8TK7R1					
IC710	8-759-598-69	IC BA6956AN					
IC712	6-702-157-01	IC FAN8035L					
IC920	6-705-463-01	IC BA33BC0T					
IC950	6-705-469-01	IC BA50BC0FP-E2					
IC985	8-759-460-81	IC BA12FP-E2					
		< TRANSISTOR >					
J351	1-785-536-11	JACK, PIN 6P (5.1CH OUT)(ANALOG)					
		< TRANSISTOR >					
Q301	8-729-924-04	TRANSISTOR UN5116-TX					
Q303	8-729-924-04	TRANSISTOR UN5116-TX					
Q305	8-729-924-04	TRANSISTOR UN5116-TX					
Q401	8-729-141-73	TRANSISTOR 2SC3624A-T1L15L16					
Q402	8-729-141-73	TRANSISTOR 2SC3624A-T1L15L16					
Q431	8-729-141-73	TRANSISTOR 2SC3624A-T1L15L16					
Q432	8-729-141-73	TRANSISTOR 2SC3624A-T1L15L16					
Q462	8-729-141-73	TRANSISTOR 2SC3624A-T1L15L16					
Q463	8-729-141-73	TRANSISTOR 2SC3624A-T1L15L16					
Q501	8-729-141-73	TRANSISTOR 2SC3624A-T1L15L16					
Q502	8-729-141-73	TRANSISTOR 2SC3624A-T1L15L16					
Q531	8-729-141-73	TRANSISTOR 2SC3624A-T1L15L16					
Q532	8-729-141-73	TRANSISTOR 2SC3624A-T1L15L16					
Q562	8-729-141-73	TRANSISTOR 2SC3624A-T1L15L16					
Q563	8-729-141-73	TRANSISTOR 2SC3624A-T1L15L16					
Q701	8-729-027-56	TRANSISTOR DTC143TKA-T146					
Q961	8-729-027-56	TRANSISTOR DTC143TKA-T146					
Q971	8-729-019-72	TRANSISTOR 2SB1260T100					
		< RESISTOR >					
R201	1-216-833-11	METAL CHIP 10K 5% 1/10W					
R202	1-216-839-11	METAL CHIP 33K 5% 1/10W					
R321	1-216-857-11	METAL CHIP 1M 5% 1/10W					
R322	1-216-864-11	SHORT CHIP 0					
R323	1-216-821-11	METAL CHIP 1K 5% 1/10W					
R324	1-216-809-11	METAL CHIP 100 5% 1/10W					
R326	1-216-801-11	METAL CHIP 22 5% 1/10W					
R328	1-216-801-11	METAL CHIP 22 5% 1/10W					
R330	1-216-801-11	METAL CHIP 22 5% 1/10W					
R404	1-216-827-11	METAL CHIP 3.3K 5% 1/10W					
R407	1-216-845-11	METAL CHIP 100K 5% 1/10W					
R408	1-216-815-11	METAL CHIP 330 5% 1/10W					
R409	1-216-813-11	METAL CHIP 220 5% 1/10W					
R411	1-216-809-11	METAL CHIP 100 5% 1/10W					
R434	1-216-827-11	METAL CHIP 3.3K 5% 1/10W					
R437	1-216-845-11	METAL CHIP 100K 5% 1/10W					
R438	1-216-815-11	METAL CHIP 330 5% 1/10W					
R439	1-216-813-11	METAL CHIP 220 5% 1/10W					
R464	1-216-827-11	METAL CHIP 3.3K 5% 1/10W					
R467	1-216-845-11	METAL CHIP 100K 5% 1/10W					
R468	1-216-815-11	METAL CHIP 330 5% 1/10W					
R469	1-216-813-11	METAL CHIP 220 5% 1/10W					
R504	1-216-827-11	METAL CHIP 3.3K 5% 1/10W					
R507	1-216-845-11	METAL CHIP 100K 5% 1/10W					
R508	1-216-815-11	METAL CHIP 330 5% 1/10W					
R509	1-216-813-11	METAL CHIP 220 5% 1/10W					
R511	1-216-809-11	METAL CHIP 100 5% 1/10W					
R534	1-216-827-11	METAL CHIP 3.3K 5% 1/10W					
R537	1-216-845-11	METAL CHIP 100K 5% 1/10W					
R538	1-216-815-11	METAL CHIP 330 5% 1/10W					
R539	1-216-813-11	METAL CHIP 220 5% 1/10W					

MAIN

MD-94

Ref. No.	Part No.	Description	Quantity	Percentage	Remark
R564	1-216-827-11	METAL CHIP	3.3K	5%	1/10W
R567	1-216-845-11	METAL CHIP	100K	5%	1/10W
R568	1-216-815-11	METAL CHIP	330	5%	1/10W
R569	1-216-813-11	METAL CHIP	220	5%	1/10W
R701	1-216-821-11	METAL CHIP	1K	5%	1/10W
R702	1-216-833-11	METAL CHIP	10K	5%	1/10W
R703	1-216-833-11	METAL CHIP	10K	5%	1/10W
R707	1-216-821-11	METAL CHIP	1K	5%	1/10W
R708	1-216-809-11	METAL CHIP	100	5%	1/10W
R734	1-216-833-11	METAL CHIP	10K	5%	1/10W
R752	1-216-864-11	SHORT CHIP	0		
R781	1-216-821-11	METAL CHIP	1K	5%	1/10W
R782	1-216-841-11	METAL CHIP	47K	5%	1/10W
R783	1-216-833-11	METAL CHIP	10K	5%	1/10W
R791	1-216-805-11	METAL CHIP	47	5%	1/10W
R804	1-216-815-11	METAL CHIP	330	5%	1/10W
R806	1-216-150-91	RES-CHIP	10	5%	1/8W
R815	1-216-809-11	METAL CHIP	100	5%	1/10W
R818	1-216-809-11	METAL CHIP	100	5%	1/10W
R819	1-216-847-11	METAL CHIP	150K	5%	1/10W
R820	1-216-847-11	METAL CHIP	150K	5%	1/10W
R828	1-216-813-11	METAL CHIP	220	5%	1/10W
R831	1-216-833-11	METAL CHIP	10K	5%	1/10W
R840	1-216-845-11	METAL CHIP	100K	5%	1/10W
R846	1-216-842-11	METAL CHIP	56K	5%	1/10W
R848	1-216-821-11	METAL CHIP	1K	5%	1/10W
R851	1-216-825-11	METAL CHIP	2.2K	5%	1/10W
R852	1-216-839-11	METAL CHIP	33K	5%	1/10W
R853	1-216-842-11	METAL CHIP	56K	5%	1/10W
R857	1-216-839-11	METAL CHIP	33K	5%	1/10W
R858	1-216-846-11	METAL CHIP	120K	5%	1/10W
R860	1-216-855-11	METAL CHIP	680K	5%	1/10W
R861	1-216-850-11	METAL CHIP	270K	5%	1/10W
R865	1-216-842-11	METAL CHIP	56K	5%	1/10W
R866	1-216-839-11	METAL CHIP	33K	5%	1/10W
R869	1-216-842-11	METAL CHIP	56K	5%	1/10W
R870	1-216-839-11	METAL CHIP	33K	5%	1/10W
R871	1-216-833-11	METAL CHIP	10K	5%	1/10W
R872	1-216-833-11	METAL CHIP	10K	5%	1/10W
R874	1-216-839-11	METAL CHIP	33K	5%	1/10W
R876	1-216-844-11	METAL CHIP	82K	5%	1/10W
R877	1-216-853-11	METAL CHIP	470K	5%	1/10W
R878	1-216-853-11	METAL CHIP	470K	5%	1/10W
R880	1-216-845-11	METAL CHIP	100K	5%	1/10W
R885	1-216-835-11	METAL CHIP	15K	5%	1/10W
R886	1-216-844-11	METAL CHIP	82K	5%	1/10W
R888	1-216-835-11	METAL CHIP	15K	5%	1/10W
R889	1-216-864-11	SHORT CHIP	0		
R892	1-216-846-11	METAL CHIP	120K	5%	1/10W
R893	1-216-846-11	METAL CHIP	120K	5%	1/10W
R894	1-216-842-11	METAL CHIP	56K	5%	1/10W
R895	1-216-842-11	METAL CHIP	56K	5%	1/10W
R897	1-216-853-11	METAL CHIP	470K	5%	1/10W
R899	1-216-849-11	METAL CHIP	220K	5%	1/10W
R961	1-216-821-11	METAL CHIP	1K	5%	1/10W
R962	1-216-821-11	METAL CHIP	1K	5%	1/10W

Ref. No.	Part No.	Description	Quantity	Percentage	Remark
R963	1-216-821-11	METAL CHIP	1K	5%	1/10W
R971	1-216-833-11	METAL CHIP	10K	5%	1/10W
R972	1-216-833-11	METAL CHIP	10K	5%	1/10W
R973	1-216-827-11	METAL CHIP	3.3K	5%	1/10W
R975	1-216-839-11	METAL CHIP	33K	5%	1/10W
R976	1-216-809-11	METAL CHIP	100	5%	1/10W
R977	1-216-809-11	METAL CHIP	100	5%	1/10W
R978	1-216-837-11	METAL CHIP	22K	5%	1/10W
R979	1-216-833-11	METAL CHIP	10K	5%	1/10W
< COMPOSITION CIRCUIT BLOCK >					
RB301	1-233-414-11	RES, CHIP NETWORK			4.7K (3216)
RB302	1-233-873-21	RES, CHIP NETWORK			220K (3216)
RB402	1-233-419-21	RES, CHIP NETWORK			6.8K (3216)
RB410	1-233-413-11	RES, CHIP NETWORK			2.2K (3216)
RB432	1-233-419-21	RES, CHIP NETWORK			6.8K (3216)
RB441	1-233-413-11	RES, CHIP NETWORK			2.2K (3216)
RB442	1-233-413-11	RES, CHIP NETWORK			2.2K (3216)
RB462	1-233-419-21	RES, CHIP NETWORK			6.8K (3216)
RB502	1-233-419-21	RES, CHIP NETWORK			6.8K (3216)
RB532	1-233-419-21	RES, CHIP NETWORK			6.8K (3216)
RB562	1-233-419-21	RES, CHIP NETWORK			6.8K (3216)
RB601	1-236-908-11	RES, CHIP NETWORK			10K (3216)
RB602	1-233-412-11	RES, CHIP NETWORK			1.0K (3216)
RB603	1-233-577-11	RES, CHIP NETWORK			470 (3216)
RB604	1-233-414-11	RES, CHIP NETWORK			4.7K (3216)
RB605	1-236-908-11	RES, CHIP NETWORK			10K (3216)
RB606	1-236-908-11	RES, CHIP NETWORK			10K (3216)
RB607	1-236-908-11	RES, CHIP NETWORK			10K (3216)
RB608	1-233-578-11	RES, CHIP NETWORK			47K (3216)
RB609	1-236-908-11	RES, CHIP NETWORK			10K (3216)
RB610	1-233-578-11	RES, CHIP NETWORK			47K (3216)
RB611	1-236-908-11	RES, CHIP NETWORK			10K (3216)
RB612	1-236-908-11	RES, CHIP NETWORK			10K (3216)
RB613	1-236-908-11	RES, CHIP NETWORK			10K (3216)
RB615	1-233-577-11	RES, CHIP NETWORK			470 (3216)
RB616	1-233-577-11	RES, CHIP NETWORK			470 (3216)
RB617	1-233-577-11	RES, CHIP NETWORK			470 (3216)
< VIBRATOR >					
X321	1-795-535-21	VIBRATOR, CRYSTAL 11.2896MHZ			

MD-94 BOARD, COMPLETE					

< CONNECTOR >					
CN001	1-506-490-21	PIN, CONNECTOR 11P			
CN002	1-784-767-11	CONNECTOR, FFC 6P			
* CN003	1-564-013-11	PIN, CONNECTOR 3P			
CN004	1-506-481-11	PIN, CONNECTOR 2P			
< SWITCH >					
S001	1-786-514-21	SWITCH, LEVER (SLIDE)			

SCD-CE595

POWER SW	PT	RF
-----------------	-----------	-----------

Ref. No.	Part No.	Description	Remark
	1-862-176-11	POWER SW BOARD *****	
		< CAPACITOR >	
△ C891	1-113-920-11	CERAMIC 0.0022uF 20%	250V
		< CONNECTOR >	
* CN891	1-580-230-31	PIN, CONNECTOR (PC BOARD) 2P	
		< SWITCH >	
△ S891	1-762-581-11	SWITCH, AC POWER PUSH (1 KEY) (POWER)	

	1-862-175-11	PT BOARD *****	
		< CAPACITOR >	
△ C101	1-113-920-11	CERAMIC 0.0022uF 20%	250V
		< CONNECTOR >	
* CN101	1-568-226-11	PIN, CONNECTOR (3.96mm PITCH) 2P	

	A-4750-527-A	RF BOARD, COMPLETE *****	
		< CAPACITOR >	
C001	1-107-726-91	CERAMIC CHIP 0.01uF 10%	16V
C002	1-107-726-91	CERAMIC CHIP 0.01uF 10%	16V
C004	1-124-778-00	ELECT CHIP 22uF 20%	6.3V
C005	1-162-966-11	CERAMIC CHIP 0.0022uF 10%	50V
C006	1-162-966-11	CERAMIC CHIP 0.0022uF 10%	50V
C007	1-162-966-11	CERAMIC CHIP 0.0022uF 10%	50V
C008	1-162-966-11	CERAMIC CHIP 0.0022uF 10%	50V
C009	1-124-779-00	ELECT CHIP 10uF 20%	16V
C011	1-107-726-91	CERAMIC CHIP 0.01uF 10%	16V
C015	1-162-968-11	CERAMIC CHIP 0.0047uF 10%	50V
C016	1-162-968-11	CERAMIC CHIP 0.0047uF 10%	50V
C017	1-126-206-11	ELECT CHIP 100uF 20%	6.3V
C018	1-115-416-11	CERAMIC CHIP 0.001uF 5%	25V
C019	1-164-739-11	CERAMIC CHIP 560PF 5%	50V
C021	1-124-779-00	ELECT CHIP 10uF 20%	16V
C022	1-107-826-11	CERAMIC CHIP 0.1uF 10%	16V
C023	1-126-206-11	ELECT CHIP 100uF 20%	6.3V
C024	1-115-416-11	CERAMIC CHIP 0.001uF 5%	25V
C025	1-107-826-11	CERAMIC CHIP 0.1uF 10%	16V
C026	1-107-726-91	CERAMIC CHIP 0.01uF 10%	16V
C027	1-107-726-91	CERAMIC CHIP 0.01uF 10%	16V
C028	1-107-826-11	CERAMIC CHIP 0.1uF 10%	16V
C031	1-107-826-11	CERAMIC CHIP 0.1uF 10%	16V
C032	1-107-826-11	CERAMIC CHIP 0.1uF 10%	16V
C033	1-162-964-11	CERAMIC CHIP 0.001uF 10%	50V
C034	1-164-227-11	CERAMIC CHIP 0.022uF 10%	16V
C035	1-107-826-11	CERAMIC CHIP 0.1uF 10%	16V
C036	1-165-176-11	CERAMIC CHIP 0.047uF 10%	16V
C038	1-165-176-11	CERAMIC CHIP 0.047uF 10%	16V
C039	1-107-726-91	CERAMIC CHIP 0.01uF 10%	16V

Ref. No.	Part No.	Description	Remark
C040	1-164-217-11	CERAMIC CHIP 150PF 5%	50V
C043	1-107-826-11	CERAMIC CHIP 0.1uF 10%	16V
C044	1-124-779-00	ELECT CHIP 10uF 20%	16V
C046	1-107-726-91	CERAMIC CHIP 0.01uF 10%	16V
C047	1-107-826-11	CERAMIC CHIP 0.1uF 10%	16V
C048	1-107-726-91	CERAMIC CHIP 0.01uF 10%	16V
		< CONNECTOR >	
CN001	1-815-031-11	CONNECTOR, FFC/FPC (ZIF) 24P	
CN002	1-784-879-21	CONNECTOR, FFC (LIF (NON-ZIF)) 31P	
CN003	1-784-861-21	CONNECTOR, FFC (LIF (NON-ZIF)) 9P	
		< DIODE >	
D001	8-719-988-61	DIODE 1SS355TE-17	
D004	8-719-988-61	DIODE 1SS355TE-17	
		< IC >	
IC001	6-703-445-01	IC SP3726A	
		< COIL >	
L001	1-412-031-11	INDUCTOR 47uH	
L002	1-412-031-11	INDUCTOR 47uH	
		< TRANSISTOR >	
Q001	8-729-903-46	TRANSISTOR 2SB1132-T100-QR	
Q002	8-729-903-46	TRANSISTOR 2SB1132-T100-QR	
		< RESISTOR >	
R002	1-216-809-11	METAL CHIP 100 5%	1/10W
R003	1-216-809-11	METAL CHIP 100 5%	1/10W
R004	1-216-864-11	SHORT CHIP 0	
R005	1-216-845-11	METAL CHIP 100K 5%	1/10W
R006	1-216-838-11	METAL CHIP 27K 5%	1/10W
R007	1-216-803-11	METAL CHIP 33 5%	1/10W
R008	1-216-803-11	METAL CHIP 33 5%	1/10W
R009	1-216-820-11	METAL CHIP 820 5%	1/10W
R010	1-216-841-11	METAL CHIP 47K 5%	1/10W
R011	1-216-809-11	METAL CHIP 100 5%	1/10W
R013	1-216-833-11	METAL CHIP 10K 5%	1/10W
R018	1-216-833-11	METAL CHIP 10K 5%	1/10W
R020	1-216-803-11	METAL CHIP 33 5%	1/10W
R023	1-216-803-11	METAL CHIP 33 5%	1/10W
R025	1-216-841-11	METAL CHIP 47K 5%	1/10W
R029	1-216-809-11	METAL CHIP 100 5%	1/10W
R037	1-216-834-11	METAL CHIP 12K 5%	1/10W
R038	1-216-861-11	METAL CHIP 2.2M 5%	1/10W
R045	1-216-813-11	METAL CHIP 220 5%	1/10W
R052	1-216-864-11	SHORT CHIP 0	
R053	1-216-864-11	SHORT CHIP 0	
R054	1-216-864-11	SHORT CHIP 0	
R055	1-216-864-11	SHORT CHIP 0	

The components identified by mark △ or dotted line with mark △ are critical for safety. Replace only with part number specified.	Les composants identifiés par une marque △ sont critiques pour la sécurité. Ne les remplacer que par une pièce portant le numéro spécifié.
--	--

Ref. No.	Part No.	Description	Remark
	A-6060-642-A	SE-130 BOARD *****	
		< CONNECTOR >	
CN101	1-750-243-11	SOCKET, CONNECTOR 6P	
CN102	1-573-383-11	PIN, CONNECTOR (PC BOARD) 2P	
		< PHONT SENSOR >	
PH101	8-749-017-45	SENSOR, PHONT RPR-220C1N	
PH102	6-600-072-01	IC RPI-392	

		MISCELLANEOUS *****	
56	1-828-334-11	WIRE (FLAT TYPE) (13 CORE)	
△ 104	1-777-071-43	CORD, POWER (AEP,UK)	
△ 104	1-783-531-32	CORD, POWER (US,CND)	
207	1-829-172-11	WIRE (FLAT TYPE) (31 CORE)	
△ 216	A-1067-676-A	DEVICE, OPTICAL (DBU-3)	
218	1-824-106-12	CABLE, FLEXIBLE FLAT (24 CORE)	
M901	1-541-632-12	MOTOR, DC	
RE901	1-418-746-11	ENCODER, ROTARY	
△ T101	1-443-286-11	TRANSFORMER, POWER (US,CND)	
△ T101	1-443-287-11	TRANSFORMER, POWER (AEP,UK)	
		ACCESSORIES *****	
	1-478-636-11	COMMANDER, STANDARD (RM-SX800)	
	1-790-735-12	CORD, CONNECTION	
	2-103-393-11	MANUAL, INSTRUCTION (ENGLISH)(US)	
	2-103-393-21	MANUAL, INSTRUCTION (FRENCH, ENGLISH)(CND)	
	2-103-393-31	MANUAL, INSTRUCTION (GERMAN, SPANISH, FRENCH, ENGLISH)(AEP,UK)	
	2-103-393-41	MANUAL, INSTRUCTION (ITALIAN, DUTCH, POLISH, SWEDISH)(AEP)	

The components identified by mark △ or dotted line with mark △ are critical for safety. Replace only with part number specified.

Les composants identifiés par une marque △ sont critiques pour la sécurité. Ne les remplacer que par une pièce portant le numéro spécifié.

MEMO

SCD-CE595

SONY®

SERVICE MANUAL

Ver. 1.1 2005.05

*US Model
Canadian Model
AEP Model
UK Model*

SUPPLEMENT-1

Subject: TEST MODE and ELECTRICAL ADJUSTMENT

SECTION 1 TEST MODE

1. DIAG MODE of The Test Mode

While press **[MENU]** and **[PUSH ENTER]** buttons, press the **[POWER]** button to turn the power on and enter the Test Mode and display “DIAG MODE”.

2. Operating The Test Mode

Procedure:

1. Turn the **[◀◀ AMS ▶▶]** knob to select the command number (hexadecimal number) (refer to the following table for command number).
2. Press the **[PUSH ENTER]** button to execute the selected command item.

3. The Commands in Test Mode

Command No.	Command name	Item
12	LD ON/OFF	Turn on/off the laser diode
13	SPIN ON/OFF	Turn on/off the spindle motor
14	FSRV ON/OFF	Turn on/off the focus servo
15	TSRV ON/OFF	Turn on/off the tracking servo
16	CLV ON/OFF	Turn on/off the spindle CLV servo, when both focus servo and tracking servo are on
17	SSRV ON/OFF	Turn on/off the spindle CLV servo, when all servo of focus servo, tracking servo and spindle servo are on
18	ALL SRV ON	Turn on all servo
19	ALL SRV OFF	Turn off all servo
1A	DISC STOP	Stop the disc rotation (useful as overdrived)
24	ADJ FCSBIAS	Automatically adjust the focus bias (*1)
27	FOCUS AGC	Automatically adjust the focus servo gain (*1)
31	PI/FE OFFSET	Automatically adjust the offset signal of PI, PE and TE (*1)
45	TRACKING AGC	Automatically adjust the focus servo gain (*1)
61	DISC DETECT	Judge the disc type (when SA-CD, “SL” or “DL” is displayed)
7C	FJUMP TEST	Focus jump test mode
81	SYSTEM VERSION	Display the version of system microcomputer for 2 seconds
82	I/F VERSION	Display the version of IF microcomputer for 2 seconds
8D	CEL	Initialization
8F	U&OTHERS	Initialization
92	ERR CHECK	Error rate display (to stop, press the x button) for CD display “92 C1 C2 0xff” for SA-CD display “92 PI1 PO PI2”
93	WATER MARK	WaterMark display display “93 xxxx” (“xxxx” is value of pspamp)
9D	PLAY&RFD ON	Measuring the jitter (to stop, press the x button) display: “9D xx 0xff 0xff” (“xx” is measuring value of jitter)

*1) Not used in servicing

4. The Commands in Automatic Electrical Adjustments

(Use the commands When The system version number is ver1.24 and higher)

Command No.	Item
B0	RAM clear
B1	Writing
B2	Check writing data

SECTION 2

ELECTRICAL ADJUSTMENTS

GENERAL DESCRIPTION

After parts to the circuit (OPTICAL PICK-UP (DBU-3), RF BOARD, MAIN BOARD, EEPROM (IC702), MASTERCOM (IC705), DSP (IC706), so on) are replaced, readjusting is necessary.

1. ROM Version Check

Procedure:

1. While pressing **[PUSH ENTER]** button and **[MENU]** buttons, press the **[POWER]** button to turn the set on.
"DIAG MODE" is displayed on the screen.
2. Select "81 SYS-F VER" by tuning **[◀◀ AMS ▶▶]** knob.
3. Press **[PUSH ENTER]** button.
4. Check the version of ROM.
"SYS. VER X.XX" is displayed.
5. Select "82 I/F-F VER"
"I/F VER X.XX" is displayed.
Automatically return "81 SYS-F VER"

2. U-CON Check (The system version number is Ver 1.24 and higher)

This checking must be performed before any other checking.

CHECK DISC LIST

Use the following disc on this check.

SATD-S4: PART No. J-2501-184-A

SATD-S5: PART No. J-2501-215-A

Procedure:

1. While pressing **[PUSH ENTER]** button and **[MENU]** buttons, press the **[POWER]** button to turn the set on.
"DIAG MODE" is displayed on the screen.
2. Push the **[▲]** button to open the tray.
3. Load CD to tray.
4. Push the **[▲]** button to close the tray.
5. Turn "JOG DIAL" clockwise until "B0" and press the **[PUSH ENTER]** (Used time : 7 sec) "FFFF" is displayed.
6. Turn "JOG DIAL" clockwise until "B1" and press the **[PUSH ENTER]**.
Display shows "-9" and the numbering is counting down until "-0" lastly, "*****" (4 DIGITS VALUE) appears. (Used time : 33 sec)
7. Turn "JOG DIAL" clockwise until "B2" and press the **[PUSH ENTER]**.
Display shows the last number that appear at. STEP NO.7.
Confirm that the value is "08D0">THE VALUE>"04D0"
8. Push the **[▲]** button to open the tray.
9. Unload CD from tray.
10. Push the **[▲]** button to close the tray.
11. Press the **[POWER]** button to turn the set off. (Do not continue with another test mode without power off.)

3. Optical Sensitivity Check

CHECK DISC LIST

Use the following hybrid disc on this check.

HLXA-509 : PART No. J-6090-090-A

SACD HYBRID DISC (MARKET DISC)

Connection:

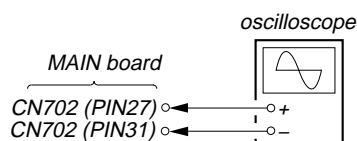

Procedure:

1. Press the **[▲]** button.
2. Insert SACD hybrid disc (market disc).
3. Connect the oscilloscope to pin 27 and pin31 of CN702.
4. Observe the MIRR waveform immediately after the disc chucking is completed when disc identification is made.

MIRR signal waveform

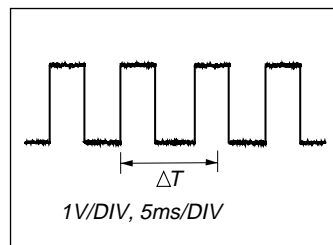

5. Read the measurement of ΔT .
IF $7.5\text{ms} < \Delta T < 9.7\text{ms}$ OK
OTHERS>NG
6. When the system version number is before ver.1.24, and if the MIRR waveform is NG (No Good), change the values of R892 and R893, and then repeat step4 and after.
 $9.7\text{ms} < \Delta t$
R892/R893 120 k Ω → 110 k Ω (1-218-741-11)
 $\Delta t < 6.9\text{ms}$
R892/R893 120 k Ω → 130 k Ω (1-218-743-11)

4. Mode Setting For Shipping (MAIN board on EEPROM (IC702) is replaced.)

Be sure to set the unit to the specified modes as stated in the steps below after sampling inspections by the QA dept.
Or before shipping.

Procedure:

1. While pressing **[PUSH ENTER]** and **[MENU]** buttons, press the **[POWER]** button to turn the set on.
"DIAG MODE" is displayed in the screen.
2. Turn jog until the specified mode (According to version) is displayed:
a) "8D SETUP" : CEL
b) "8F SETUP" : U & OTHERS
3. Press jog one single time.
"INIT START" is displayed and Mode setting for shipping starts.
4. Wait until "INITIAL OK" appears on the display.
5. By this operation, the unit is initialized as follows:

PLAY MODE	ALL DISCS
COMMAND MODE	CD 1
REPEAT	OFF
SACD/CD	SACD
M/2ch	MULTI

6. After 2 to 3 sec., Press the **[POWER]** button to turn the set off.
Note : When EEPROM (IC702) is replaced, the initialization is necessary.

