

SCD-XA9000ES

SERVICE MANUAL

Ver. 1.4 2005.11

US Model
Canadian Model
AEP Model
E Model



Model Name Using Similar Mechanism	NEW
CD Mechanism Type	CDM19JB-DVBU4C (Except AEP: Silver type) CDM19JB-DVBU4D (AEP: Silver type)
Base Unit Name	DVBU4C (Except AEP: Silver type) DVBU4D (AEP: Silver type)
Optical Pick-up Name	KHM-230AAA

SPECIFICATIONS

When a super audio CD is played

Playing frequency range	2 Hz to 100 kHz
Frequency response	2 Hz to 50 kHz (-3 dB)
Dynamic range	108 dB or more
Total harmonic distortion rate	0.0012 % or less
Wow and flutter	Value of measurable limit (± 0.001 % W. PEAK) or less

When a CD is played

Frequency response	2 Hz to 20 kHz
Dynamic range	100 dB or more
Total harmonic distortion rate	0.0017 % or less
Wow and flutter	Value of measurable limit (± 0.001 % W. PEAK) or less

Output connector

	Jack type	Output level	Load impedance
ANALOG OUT	Phono jacks	2 Vrms (at 50 kilohms)	Over 10 kilohms
DIGITAL (CD) OUT OPTICAL*	Square optical output connector	-18 dBm (Light emitting wave length: 660 nm)	
DIGITAL (CD) OUT COAXIAL*	Coaxial output connector	0.5 Vp-p	75 ohms
PHONES	Stereo phone jack	10 mW	32 ohms

*Output only the audio signals of the CD

i.LINK section

Pin	4 pins
Transmission speed	S200 (Maximum data transmission speed 200 Mbps)
Transmission protocol	A/M transmission protocol
Format (output)	Super Audio CD* (DSD PLAIN) 2 channel linear PCM (IEC 60958-3) Sampling frequency: 44.1 kHz

* Conforms to the copy protection technology of DTLA (Revision 1.2).

General

Laser	Semiconductor laser (SA-CD: $\lambda = 650$ nm) (CD: $\lambda = 780$ nm) Emission duration: continuous
Laser radiant power:	5.47 μ W at 650 nm
*These output is the value measured at a distance of about 200mm from the objective lens surface on the optical pick-up.	
Power requirements	Taiwan model: 110 V AC, 60 Hz US, Canadian models: 120 V AC, 60 Hz AEP model: 230 V AC, 50/60 Hz
Power consumption	32 W
Dimensions (w/h/d)	430 \times 127 \times 387 mm (17 \times 5 \times 15 $\frac{1}{4}$ in.) incl. projecting parts
Mass (approx.)	16.2 kg (35 lbs 12 oz.)

Supplied accessories

- Audio connecting cord phono jack \times 2 (Red and White) \leftrightarrow phono jack \times 2 (Red and White) (3)
- phono jack \times 1 (Black) \leftrightarrow phono jack \times 1 (Black) (2)
- i.LINK connecting cord (1)
- Remote commander RM-SX700 (1)
- Size AA (R6) batteries (2)
- AC power cord (1)
- Plug adapter (1) (US, Canadian models only)

Design and specifications are subject to change without notice.

SUPER AUDIO CD PLAYER

SONY®

9-961-151-05

2005K05-1

© 2005.11

Sony Corporation

Home Audio Division

Published by Sony Engineering Corporation

SAFETY CHECK-OUT

After correcting the original service problem, perform the following safety check before releasing the set to the customer: Check the antenna terminals, metal trim, "metallized" knobs, screws, and all other exposed metal parts for AC leakage. Check leakage as described below.

LEAKAGE TEST

The AC leakage from any exposed metal part to earth ground and from all exposed metal parts to any exposed metal part having a return to chassis, must not exceed 0.5 mA (500 microamperes.). Leakage current can be measured by any one of three methods.

1. A commercial leakage tester, such as the Simpson 229 or RCA WT-540A. Follow the manufacturers' instructions to use these instruments.
2. A battery-operated AC milliammeter. The Data Precision 245 digital multimeter is suitable for this job.
3. Measuring the voltage drop across a resistor by means of a VOM or battery-operated AC voltmeter. The "limit" indication is 0.75 V, so analog meters must have an accurate low-voltage scale. The Simpson 250 and Sanwa SH-63Trd are examples of a passive VOM that is suitable. Nearly all battery operated digital multimeters that have a 2 V AC range are suitable. (See Fig. A)

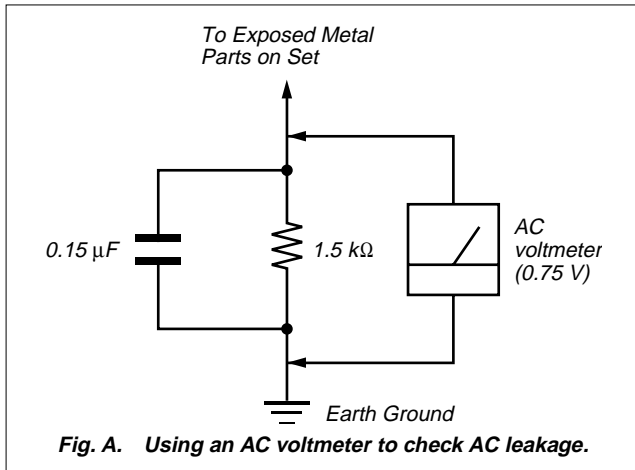

Notes on chip component replacement

- Never reuse a disconnected chip component.
- Notice that the minus side of a tantalum capacitor may be damaged by heat.

Flexible Circuit Board Repairing

- Keep the temperature of the soldering iron around 270 °C during repairing.
- Do not touch the soldering iron on the same conductor of the circuit board (within 3 times).
- Be careful not to apply force on the conductor when soldering or unsoldering.

SAFETY-RELATED COMPONENT WARNING!!

COMPONENTS IDENTIFIED BY MARK \triangle OR DOTTED LINE WITH MARK \triangle ON THE SCHEMATIC DIAGRAMS AND IN THE PARTS LIST ARE CRITICAL TO SAFE OPERATION. REPLACE THESE COMPONENTS WITH SONY PARTS WHOSE PART NUMBERS APPEAR AS SHOWN IN THIS MANUAL OR IN SUPPLEMENTS PUBLISHED BY SONY.

CAUTION

Use of controls or adjustments or performance of procedures other than those specified herein may result in hazardous radiation exposure.

CAUTION

The use of optical instruments with this product will increase eye hazard.

For the customers in Canada

This Class B digital apparatus complies with Canadian ICES-003.

AEP model

This appliance is classified as a CLASS 1 LASER product.

The CLASS 1 LASER PRODUCT

MARKING is located on the rear exterior.

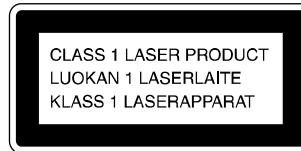

UNLEADED SOLDER

Boards requiring use of unleaded solder are printed with the lead-free mark (LF) indicating the solder contains no lead.

(Caution: Some printed circuit boards may not come printed with the lead free mark due to their particular size)

LF: LEAD FREE MARK

Unleaded solder has the following characteristics.

- Unleaded solder melts at a temperature about 40 °C higher than ordinary solder. Ordinary soldering irons can be used but the iron tip has to be applied to the solder joint for a slightly longer time. Soldering irons using a temperature regulator should be set to about 350 °C. Caution: The printed pattern (copper foil) may peel away if the heated tip is applied for too long, so be careful!
- Strong viscosity. Unleaded solder is more viscous (sticky, less prone to flow) than ordinary solder so use caution not to let solder bridges occur such as on IC pins, etc.
- Usable with ordinary solder. It is best to use only unleaded solder but unleaded solder may also be added to ordinary solder.

ATTENTION AU COMPOSANT AYANT RAPPORT À LA SÉCURITÉ!

LES COMPOSANTS IDENTIFIÉS PAR UNE MARQUE \triangle SUR LES DIAGRAMMES SCHÉMATIQUES ET LA LISTE DES PIÈCES SONT CRITIQUES POUR LA SÉCURITÉ DE FONCTIONNEMENT. NE REMPLACER CES COMPOSANTS QUE PAR DES PIÈCES SONY DONT LES NUMÉROS SONT DONNÉS DANS CE MANUEL OU DANS LES SUPPLÉMENTS PUBLIÉS PAR SONY.

TABLE OF CONTENTS

1. SERVICING NOTES	4	5-37. Schematic Diagram – PANEL Section (2/2) –	61
2. GENERAL	10	5-38. Printed Wiring Board – A-POWER Board (Component Side) –	62
3. DISASSEMBLY		5-39. Printed Wiring Boards – A-POWER (Conductor Side)/IC Boards –	63
3-1. Disassembly Flow	13	5-40. Schematic Diagram – A-POWER/IC Boards –	64
3-2. Case (Top), Side Plate	14	5-41. Printed Wiring Board – D-POWER Board –	66
3-3. Loading Panel Assy	14	5-42. Schematic Diagram – D-POWER Board –	67
3-4. Front Panel Section	15	5-43. Printed Wiring Boards – AC/AC SW Boards –	68
3-5. MAIN Board, Bracket (MAIN)	15	5-44. Schematic Diagram – AC/AC SW Boards –	69
3-6. RF Board, Mechanism Deck (CDM19JB-DVBU4C or CDM19JB-DVBU4D)	16	5-45. IC Pin Function Description	74
3-7. Disc Table, Belt, Loading Motor (M1)	16	6. EXPLODED VIEWS	
3-8. Optical Pick-up (KHM-230AAA)	17	6-1. Case Section	94
3-9. Base Unit (DVBU4C or DVBU4D)	18	6-2. Front Panel Section-1	95
4. TEST MODE	19	6-3. Front Panel Section-2	96
5. DIAGRAMS		6-4. Bottom Section	97
5-1. Block Diagram – RF/SERVO Section –	26	6-5. Board Section-1	98
5-2. Block Diagram – MAIN Section (1/2) –	27	6-6. Board Section-2	99
5-3. Block Diagram – MAIN Section (2/2) –	28	6-7. Chassis Section	100
5-4. Block Diagram – AUDIO Section (1/2) –	29	6-8. Mechanism Deck Section	101
5-5. Block Diagram – AUDIO Section (2/2) –	30	6-9. Base Unit Section	102
5-6. Block Diagram – LINK Section –	31	7. ELECTRICAL PARTS LIST	103
5-7. Block Diagram – PANEL/POWER SUPPLY Section –	32		
5-8. Note for Printed Wiring Boards and Schematic Diagrams	33		
5-9. Printed Wiring Boards – SERVO Section –	34		
5-10. Schematic Diagram – SERVO Section –	35		
5-11. Printed Wiring Board – MAIN Board (Component Side) –	36		
5-12. Printed Wiring Board – MAIN Board (Conductor Side) –	37		
5-13. Schematic Diagram – MAIN Board (1/7) –	38		
5-14. Schematic Diagram – MAIN Board (2/7) –	39		
5-15. Schematic Diagram – MAIN Board (3/7) –	40		
5-16. Schematic Diagram – MAIN Board (4/7) –	41		
5-17. Schematic Diagram – MAIN Board (5/7) –	42		
5-18. Schematic Diagram – MAIN Board (6/7) –	43		
5-19. Schematic Diagram – MAIN Board (7/7) –	44		
5-20. Printed Wiring Board – D-OUT Board –	45		
5-21. Schematic Diagram – D-OUT Board –	45		
5-22. Printed Wiring Board – MOTHER Board (Component Side) –	46		
5-23. Printed Wiring Board – MOTHER Board (Conductor Side) –	47		
5-24. Schematic Diagram – MOTHER Board (1/2) –	48		
5-25. Schematic Diagram – MOTHER Board (2/2) –	49		
5-26. Printed Wiring Board – AUDIO FRONT Board –	50		
5-27. Schematic Diagram – AUDIO FRONT Board –	51		
5-28. Printed Wiring Board – AUDIO SURR Board –	52		
5-29. Schematic Diagram – AUDIO SURR Board –	53		
5-30. Printed Wiring Board – AUDIO C/SW Board –	54		
5-31. Schematic Diagram – AUDIO C/SW Board –	55		
5-32. Schematic Diagram – LINK Board (1/2) –	56		
5-33. Schematic Diagram – LINK Board (2/2) –	57		
5-34. Printed Wiring Board – LINK Board –	58		
5-35. Printed Wiring Boards – PANEL Section –	59		
5-36. Schematic Diagram – PANEL Section (1/2) –	60		

SECTION 1 SERVICING NOTES

MODEL IDENTIFICATION

– Back Panel –

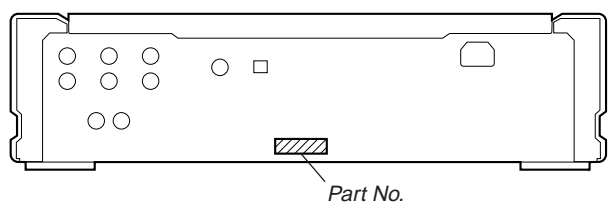

Model	Part No.
AEP model	4-247-231-0□
US and Canadian models	4-247-231-2□
Taiwan model	4-247-231-3□

NOTES ON HANDLING THE OPTICAL PICK-UP BLOCK OR BASE UNIT

The laser diode in the optical pick-up block may suffer electrostatic break-down because of the potential difference generated by the charged electrostatic load, etc. on clothing and the human body.

During repair, pay attention to electrostatic break-down and also use the procedure in the printed matter which is included in the repair parts.

The flexible board is easily damaged and should be handled with care.

NOTES ON LASER DIODE EMISSION CHECK

The laser beam on this model is concentrated so as to be focused on the disc reflective surface by the objective lens in the optical pick-up block. Therefore, when checking the laser diode emission, observe from more than 30 cm away from the objective lens.

CLEANING OF OPTICAL PICK-UP LENS

In cleaning the lens of optical pick-up, use the air blower.

Never use a cotton swab for cleaning the lens of optical pick-up, which otherwise causes a trouble.

RESETTING OPERATION AT POWER ON

If the power is turned on with a disc loaded in the set, a sequence of operation as shown below will be performed.

(The operation varies depending on the type of disc)

Condition: continue mode

(1) CD

1. Sled reverse move (sled in)
2. Disc detect
3. IC setting for CD
4. Servo error signal offset auto adjustment
5. Spindle kick for LD on
6. LD on
7. Focus search
8. Focus servo on
9. Spindle kick
10. Spindle servo on
11. E-F balance auto adjustment
12. Tracking & sled servo on
13. Focus bias auto adjustment
14. Focus servo gain auto adjustment
15. Tracking servo gain auto adjustment
16. Jump to lead-in area
17. Read TOC
18. Stop

(2) SACD (single layer)

1. Sled reverse move (sled in)
2. Disc detect
3. IC setting for SACD
4. Servo error signal offset auto adjustment
5. Spindle kick for LD on
6. LD on
7. Focus search
8. Focus servo on
9. Spindle kick
10. Spindle servo on
11. E-F balance auto adjustment
12. Tracking & sled servo on
13. Focus bias auto adjustment
14. Focus servo gain auto adjustment
15. Tracking servo gain auto adjustment
16. Jump to lead-in area
17. Read TOC
18. Stop

(3) SACD (dual layer)

1. Sled reverse move (sled in)
2. Disc detect
3. IC setting for SACD
4. Servo error signal offset auto adjustment
5. Spindle kick for LD on
6. LD on
7. Focus search
8. Focus servo on (layer 0)
9. Spindle kick
10. Spindle servo on
11. E-F balance auto adjustment (layer 0)
12. Tracking & sled servo on (layer 0)
13. Focus bias auto adjustment (layer 0)
14. Focus servo gain auto adjustment (layer 0)
15. Tracking servo gain auto adjustment (layer 0)
16. Jump to lead-in area
17. Read TOC
18. Focus jump (layer 0→layer 1)
19. E-F balance auto adjustment (layer 1)
20. Tracking & sled servo on (layer 1)
21. Focus bias auto adjustment (layer 1)
22. Focus servo gain auto adjustment (layer 1)
23. Tracking servo gain auto adjustment (layer 1)
24. Focus Jump (layer 1→layer 0)
25. Stop

HOW TO OPEN THE DISC TABLE WHEN POWER SWITCH TURNS OFF

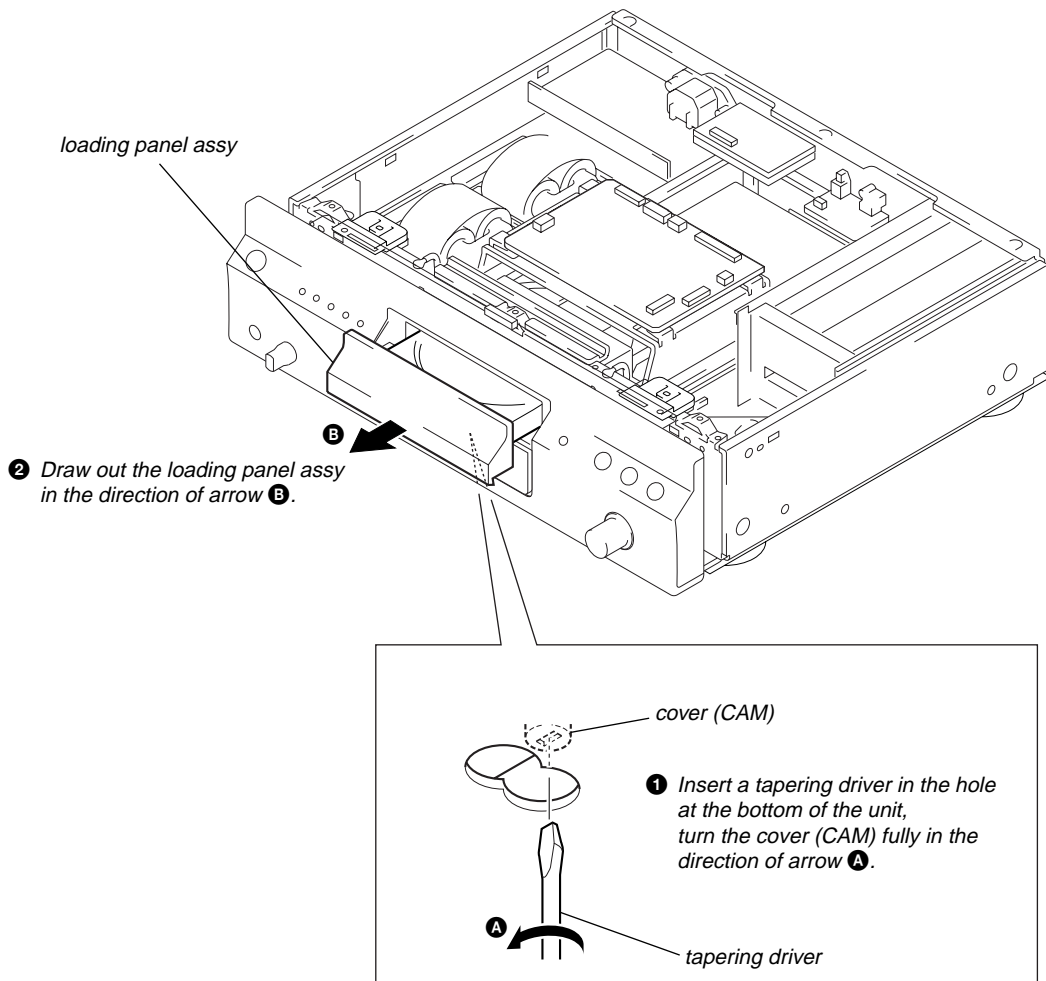

OPTICAL PICK-UP SERVICE POSITION

Place the insulator on the MAIN board, then install the base unit (DVBU4C or DVBU4D) on it as shown in the figure.

DVBU4C: Except AEP (Silver type)
DVBU4D: AEP (Silver type)

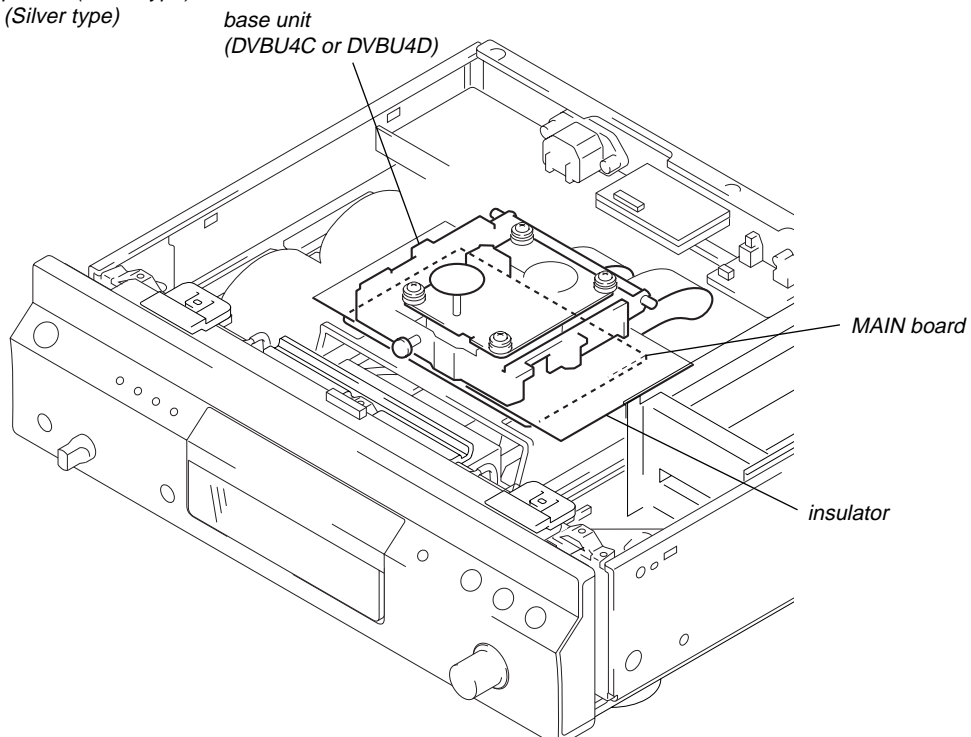

SCD-XA9000ES

Note: Follow the disassembly procedure in the numerical order given.

D-POWER/POWER BOARDS AND RF BOARD SERVICE POSITION

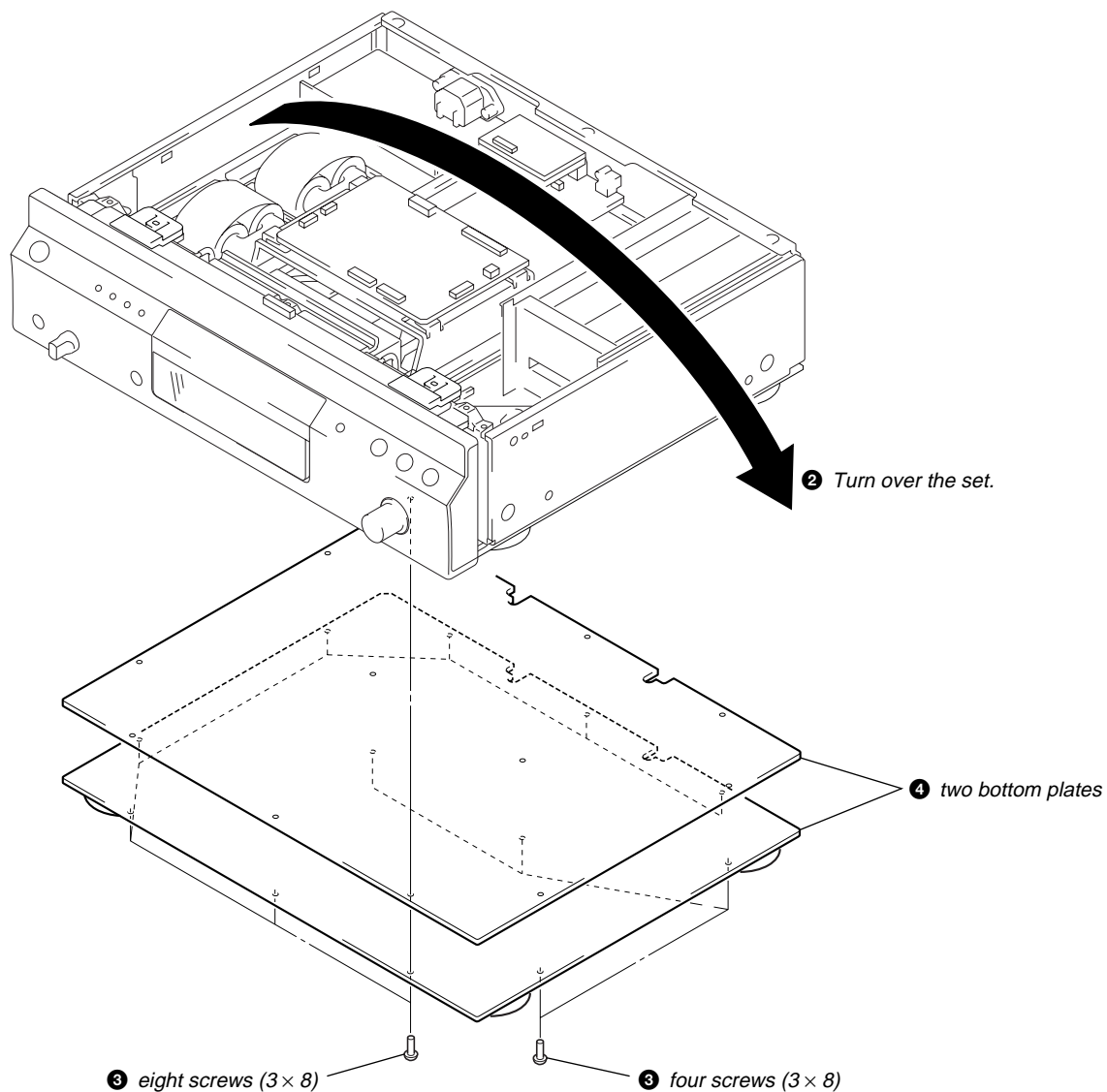

– BOTTOM VIEW –

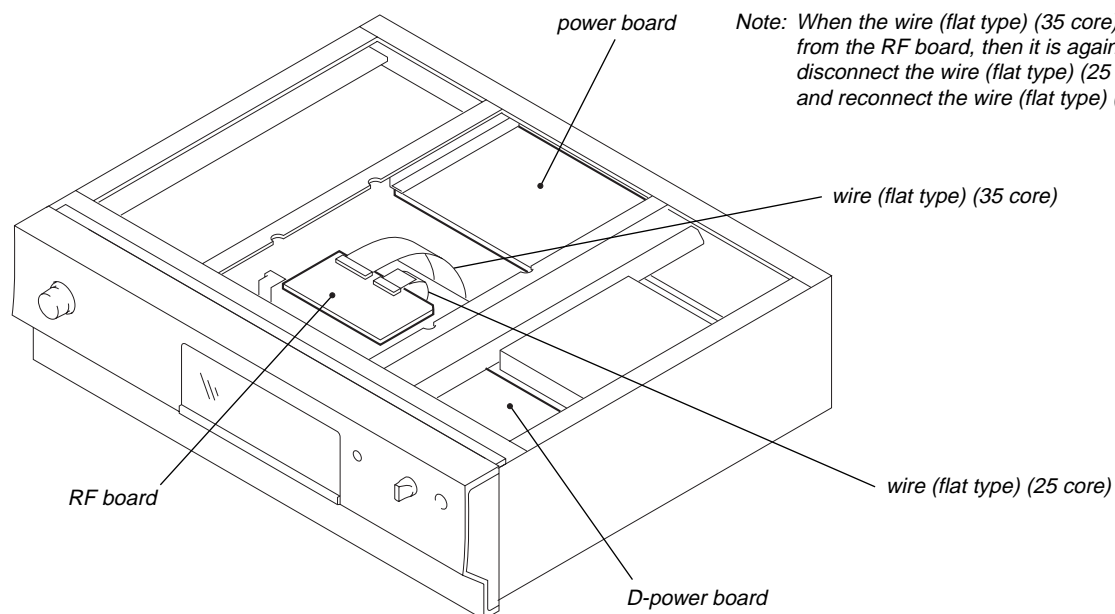

INSTALLATION TWO WIRES (FLAT TYPE) (25/35 CORE)

Note: When the wire (flat type) (35 core) is disconnected from the RF board, then it is again connected, disconnect the wire (flat type) (25 core) once, and reconnect the wire (flat type) (35 core) first.

MAIN BOARD SERVICE POSITION

In checking the MAIN board, prepare jig (extension cable J-2501-205-A: 1.50 mm Pitch, 7 cores, Length 300 mm/ J-2501-086-A: 1.00 mm Pitch, 19 cores, Length 300 mm).

Note: Be sure to ground the MAIN board with a lead wire when checking it.

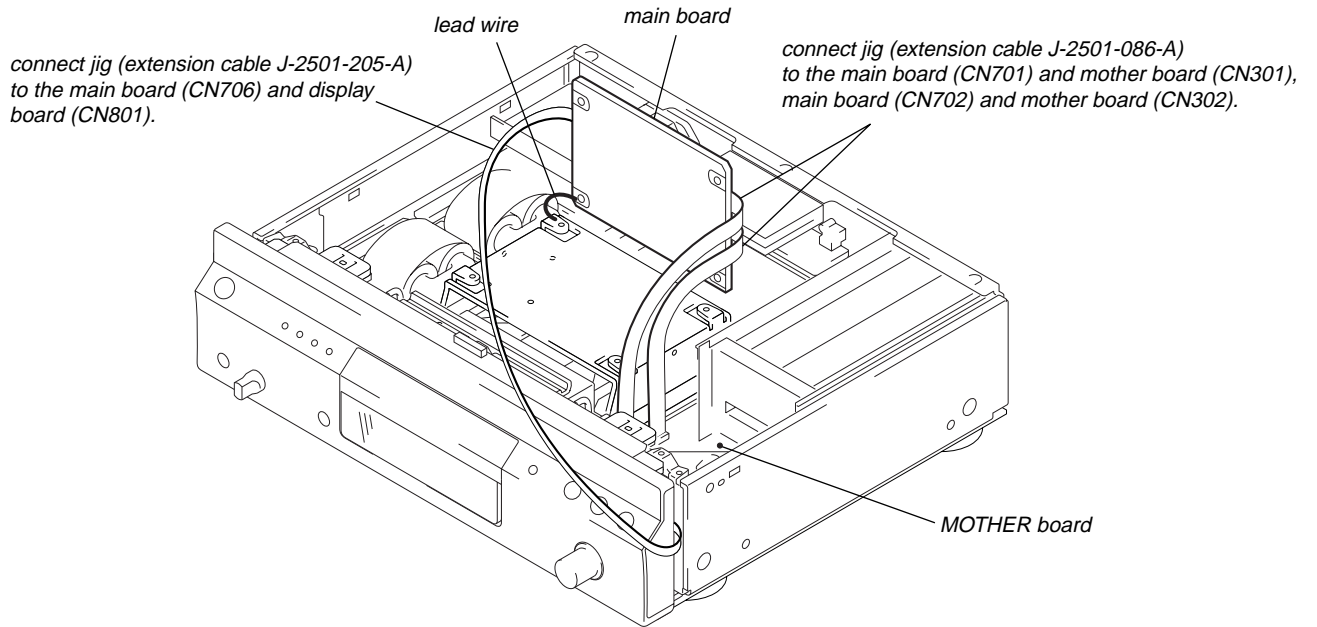

FRONT PANEL SECTION SERVICE POSITION

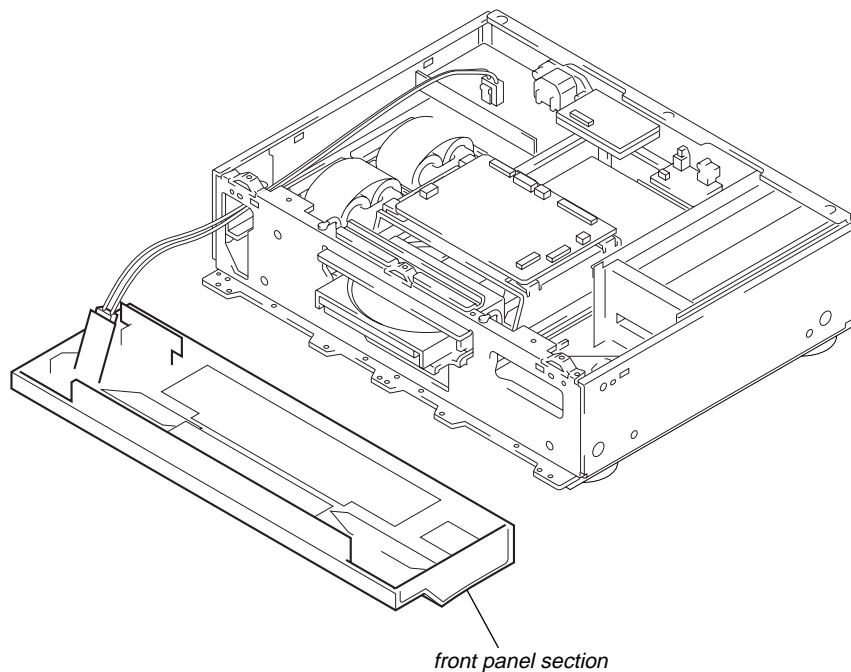

SCD-XA9000ES

AUDIO MODULE BLOCK SERVICE POSITION

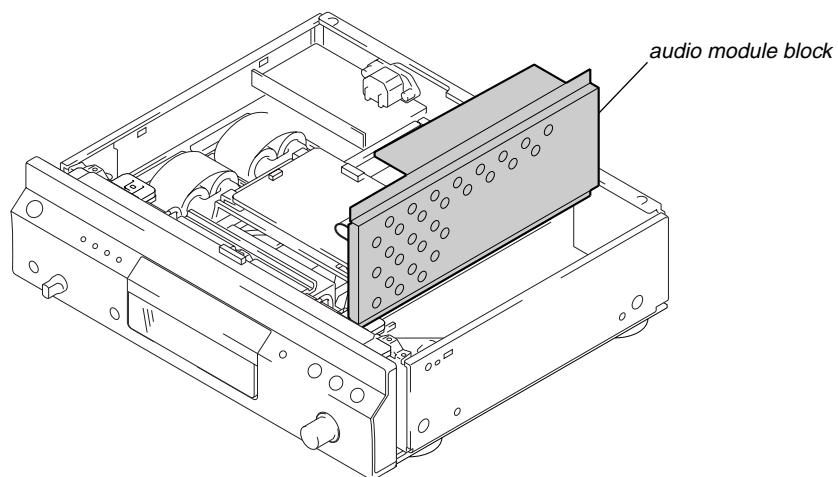

NOTE FOR INSTALLATION (AUDIO MODULE BLOCK)

Note: When installing the audio module block, insert the audio module block as shown below.

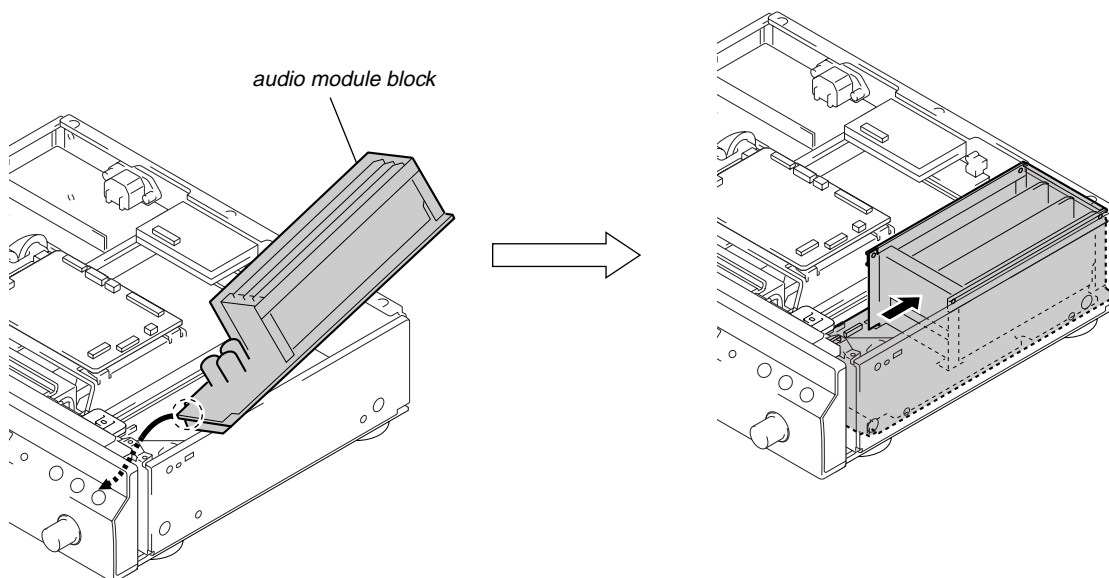

NOTE ON POSITION OF WIRE (FLAT TYPE)

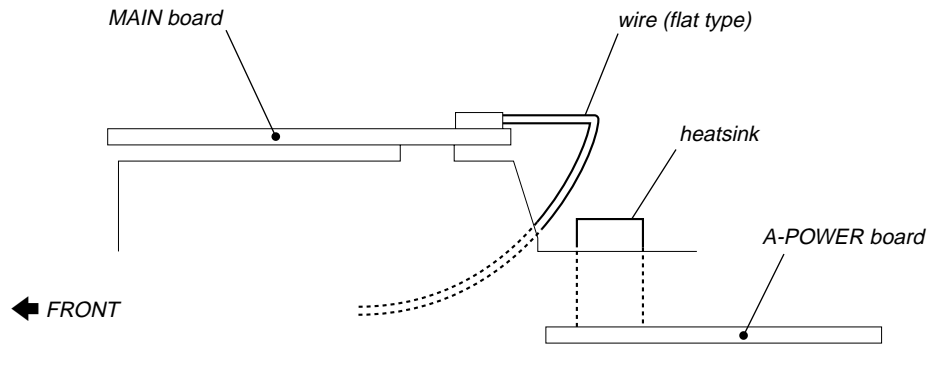

*Heatsink gets heated up to a high temperature.
Be careful to keep the position of wire (flat type).*

Front Panel Parts Descriptions

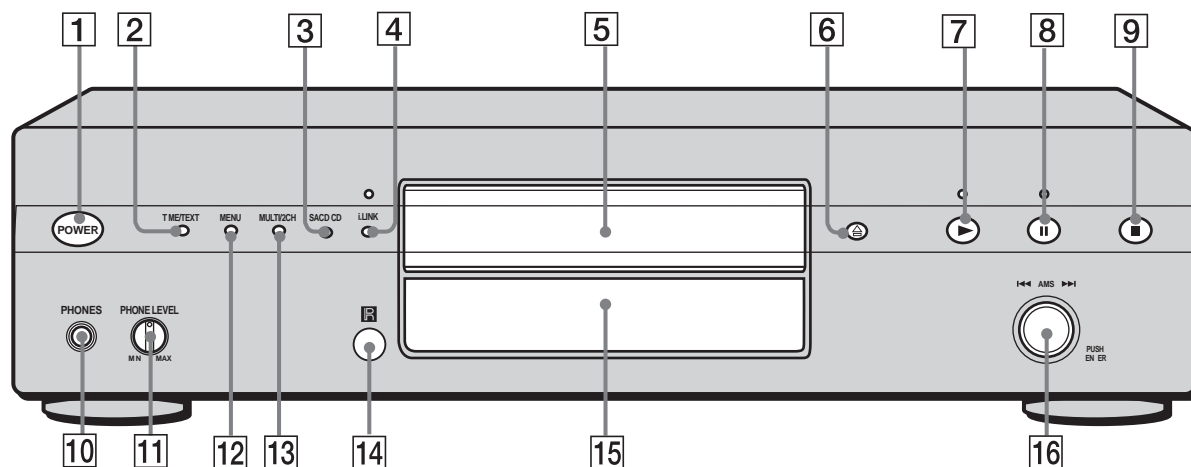
**1 POWER switch**

Press to turn on the player.

2 TIME/TEXT button

Each time you press the button, the playing time of the track, the total remaining time on the disc, or TEXT information appears in the display.

3 SACD/CD button

Each time you press the button while playing back a hybrid disc, the layer to be played back switches between the HD (Super Audio CD) layer and the CD layer.

4 i.LINK button

Each time you press the button, i.LINK function turns on or off.

i.LINK indicator

Lights up when the i.LINK function is used.

5 Disc tray

Press \ominus OPEN/CLOSE to open/close the disc tray.

6 \ominus OPEN/CLOSE button

Press to open or close the disc tray.

7 ▶ button

Press to start play.

▶ indicator

Lights up during playback.

8 || button

Press to pause play.

|| indicator

Lights up during pause.

9 ■ button

Press to stop play.

10 PHONES

Connect the headphones.

During playback of a Multi-channel Super Audio CD, the same signal that is output from the ANALOG 5.1CH FRONT L/R jacks is output from the PHONES jack.

11 PHONE LEVEL

Adjust the headphones volume.

12 MENU

Press to enter the menu.

Press to exit from the menu and return to the normal display.

13 MULTI/2CH button

Press to select the playback area when the 2 channel + Multi-channel Super Audio CD is loaded.

14 Remote sensor**15 Display window**

Shows various information.

16 ◀◀ AMS ▶▶ dial (AMS: Automatic Music Sensor)

When you turn the ◀◀ AMS ▶▶ dial counterclockwise by one click, you go back to the preceding track; when you turn the ◀◀ AMS ▶▶ dial clockwise by one click, you go to the succeeding track.

Rear Panel Parts Descriptions

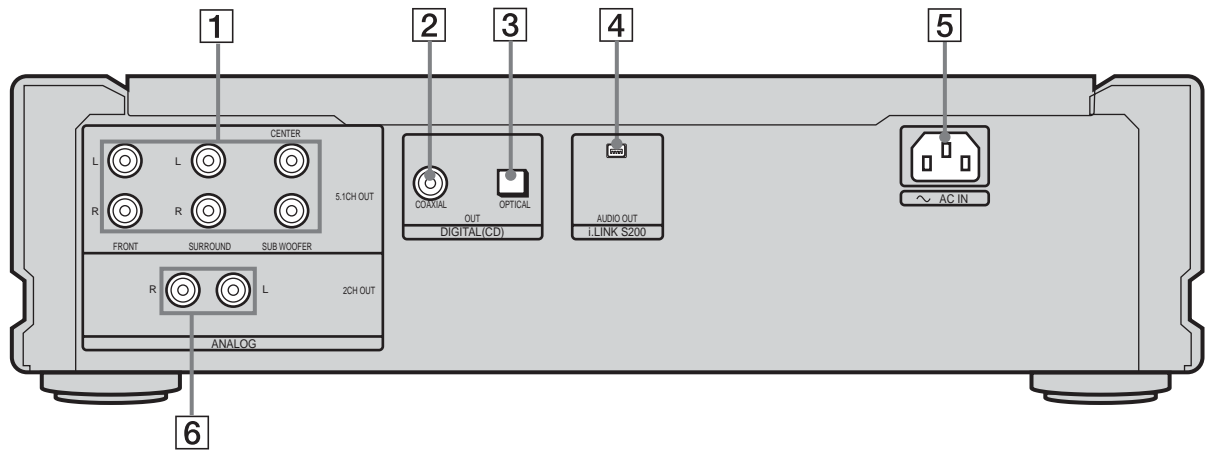

- 1 ANALOG 5.1CH OUT jacks**
Connect to an amplifier equipped with the 5.1CH input jacks (Multi-channel amplifier, AV amplifier, etc.) using the audio connecting cords.
- 2 DIGITAL (CD) OUT COAXIAL connector**
Connect to an audio component using the coaxial digital cable.
- 3 DIGITAL (CD) OUT OPTICAL connector**
Connect to an audio component using an optical digital cable.
- 4 i.LINK S200 AUDIO OUT jack**
Connect to STR-DA9000ES/TA-DA9000ES using the i.LINK connecting cord.
- 5 AC IN terminal**
Connect the AC power cord.
- 6 ANALOG 2CH OUT L/R jacks**
Connect to an audio component (stereo/2 channel) using the audio connecting cord.

Note

Only the audio signals of the CD can be output from the DIGITAL (CD) OUT connectors shown in 2 and 3. Those of the Super Audio CD cannot be output through DIGITAL (CD) OUT connectors.

When the i.LINK indicator is lit

No signal is output from all the other jacks (ANALOG 2CH OUT jacks, ANALOG 5.1CH OUT jacks, PHONES jack, DIGITAL (CD) OUT jacks).

Remote Parts Descriptions

1 CONTINUE button

Press to resume normal play from Shuffle Play or Program Play.

SHUFFLE button

Press to select Shuffle Play.

PROGRAM button

Press to select Program Play.

2 DISPLAY MODE button

Press to turn the display information off or on.

3 TIME/TEXT button

Each time you press the button, the playing time of the track, the total remaining time on the disc, or TEXT information appears in the display.

4 Number buttons

Press to enter the track numbers.

5 >10 button

Press to locate a track numbered over 10.

6 REPEAT button

Press repeatedly to play all tracks or only one track on the disc.

7 A↔B button

Press to select Repeat A-B Play.

8 ▷ button

Press to start play.

|| button

Press to pause play.

■ button

Press to stop play.

9 AMS ◀◀/▶▶ (AMS: Automatic Music Sensor) buttons

Press to locate a specific track.

10 ◀◀/▶▶ buttons

Press to locate a portion you want to play within a track.

11 INDEX ◀/▶ buttons

Press to locate a specific point marked with an index signal when you play a disc that has index signals.

12 SACD/CD button

Each time you press the button, "SACD" or "CD" appears in the display. Select the type of CD you want to play.

13 MULTI/2CH button

Press to select the playback area when the 2 channel + Multi-channel Super Audio CD is loaded.

14 ENTER button

Press to decide the selection.

15 CLEAR button

Press to delete a programmed track number.

16 LEVEL ADJ button

Press to adjust the output level balance for the Multi-channel management function.

17 CHECK button

Press to check the programmed order.

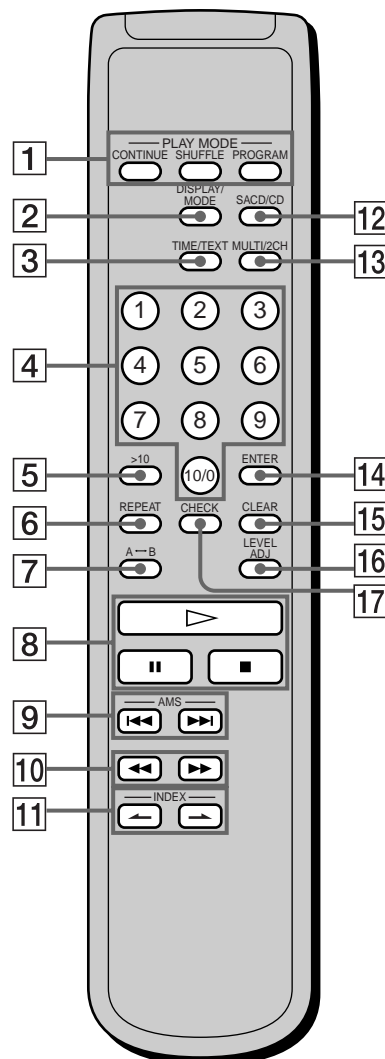

SECTION 3 DISASSEMBLY

• This set can be disassembled in the order shown below.

3-1. DISASSEMBLY FLOW

Note 1: The process described in  can be performed in any order.

Note 2: Without completing the process described in , the next process can not be performed.

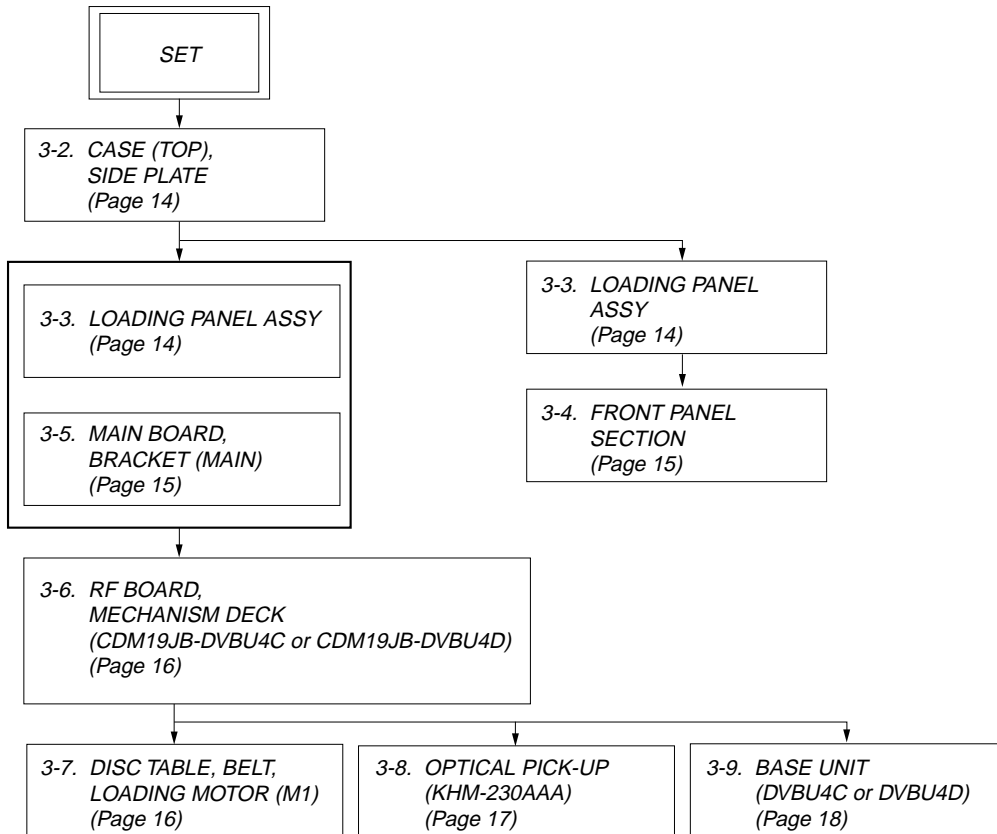

Note: Follow the disassembly procedure in the numerical order given.

3-2. CASE (TOP), SIDE PLATE

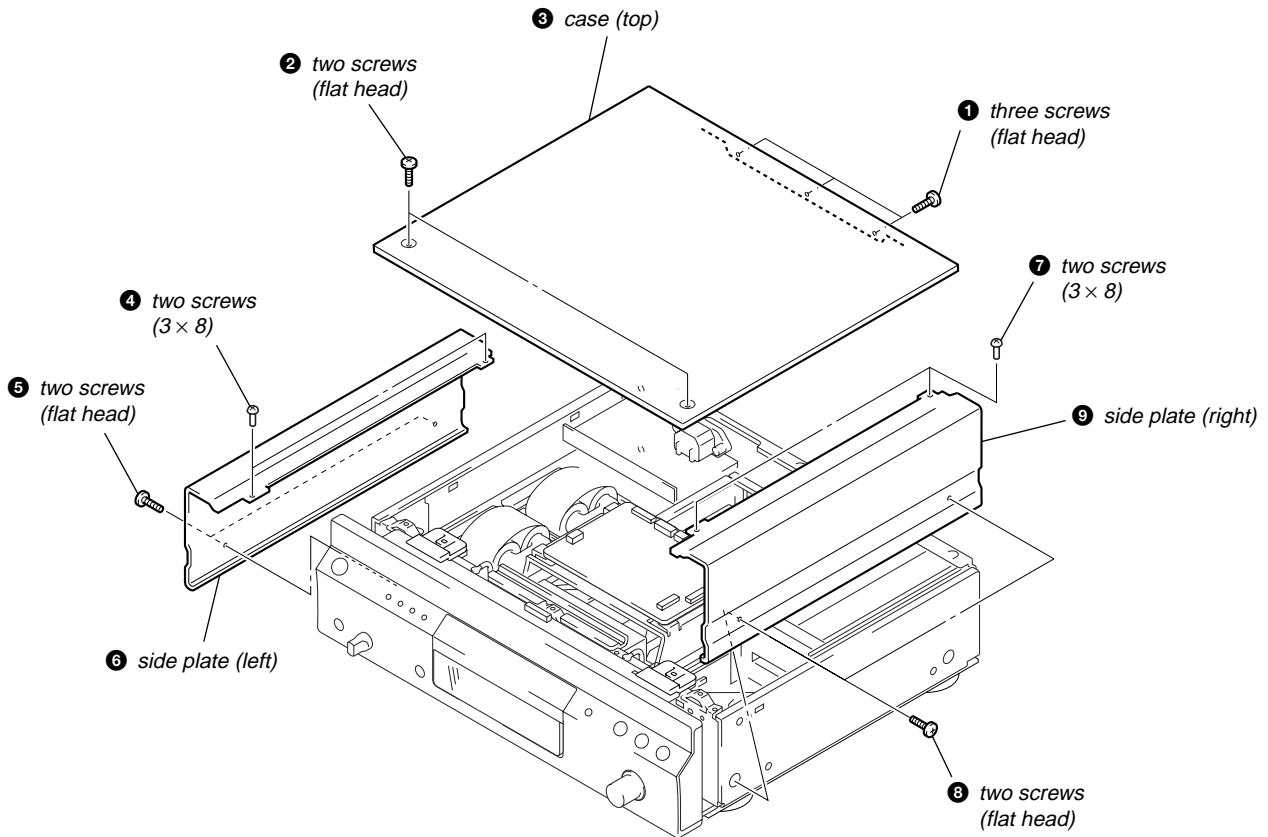

3-3. LOADING PANEL ASSY

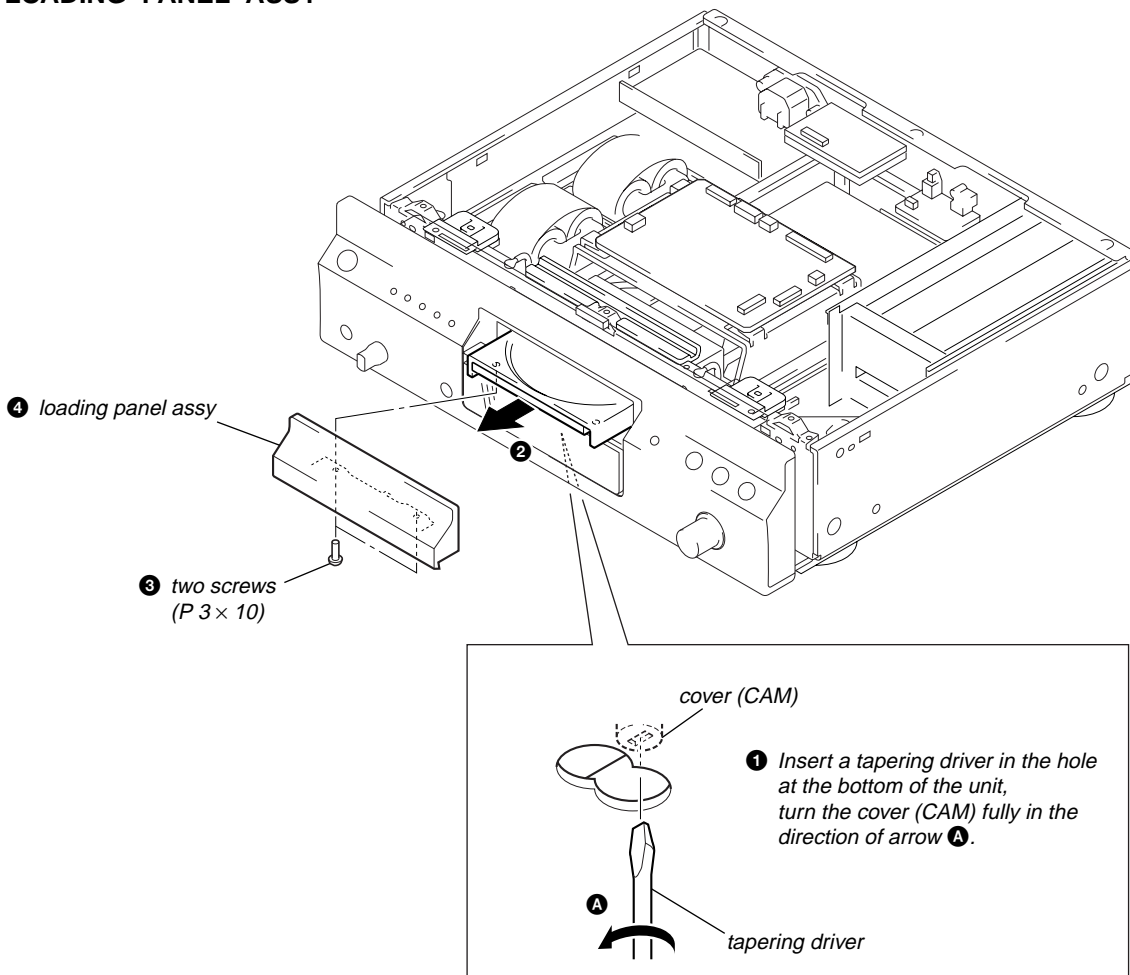

3-4. FRONT PANEL SECTION

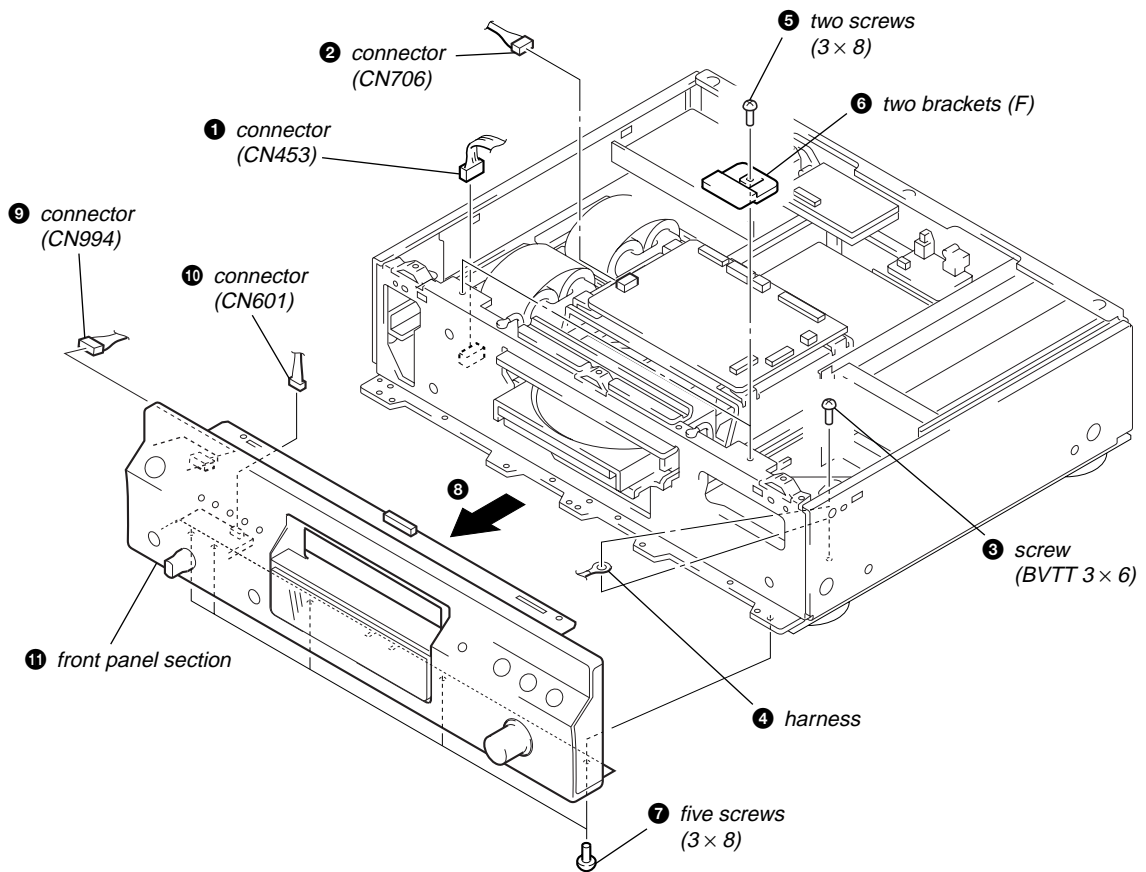

3-5. MAIN BOARD, BRACKET (MAIN)

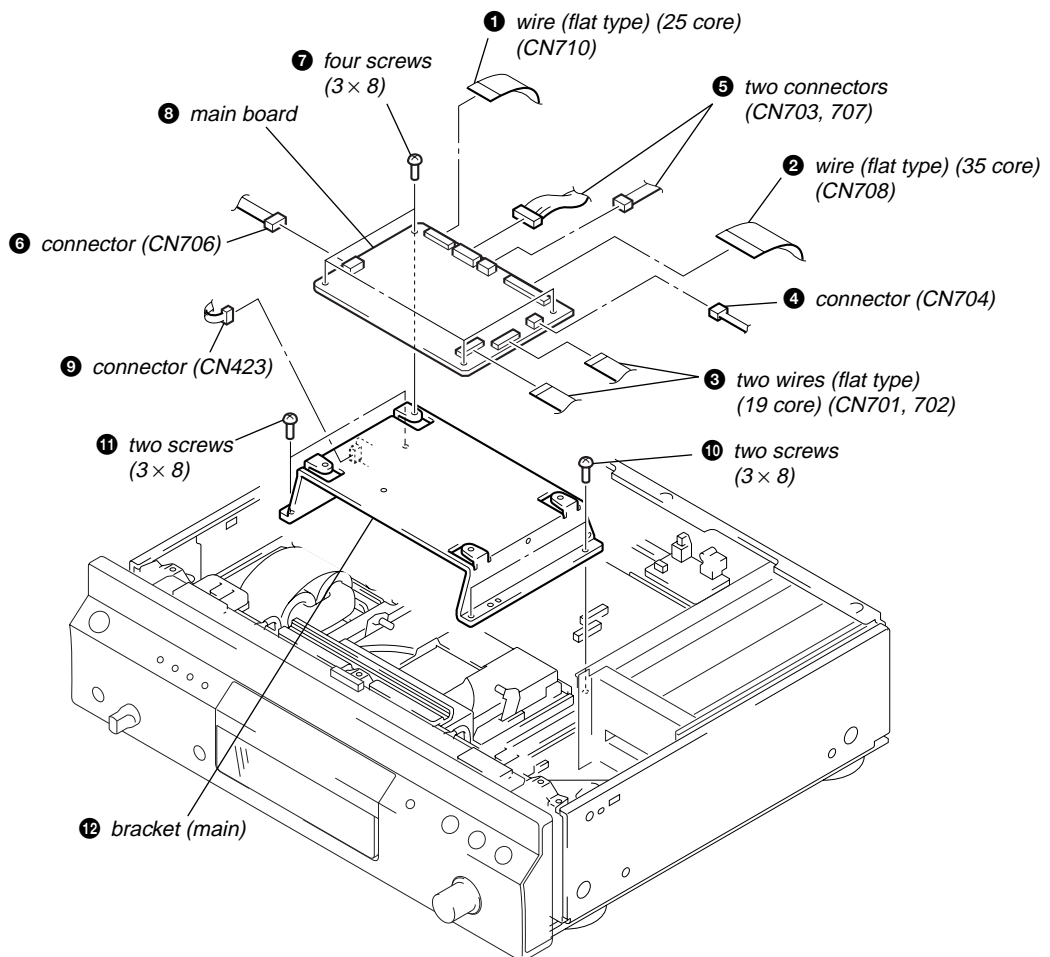

3-6. RF BOARD, MECHANISM DECK (CDM19JB-DVBU4C or CDM19JB-DVBU4D)

CDM19JB-DVBU4C: Except AEP (Silver type)
 CDM19JB-DVBU4D: AEP (Silver type)

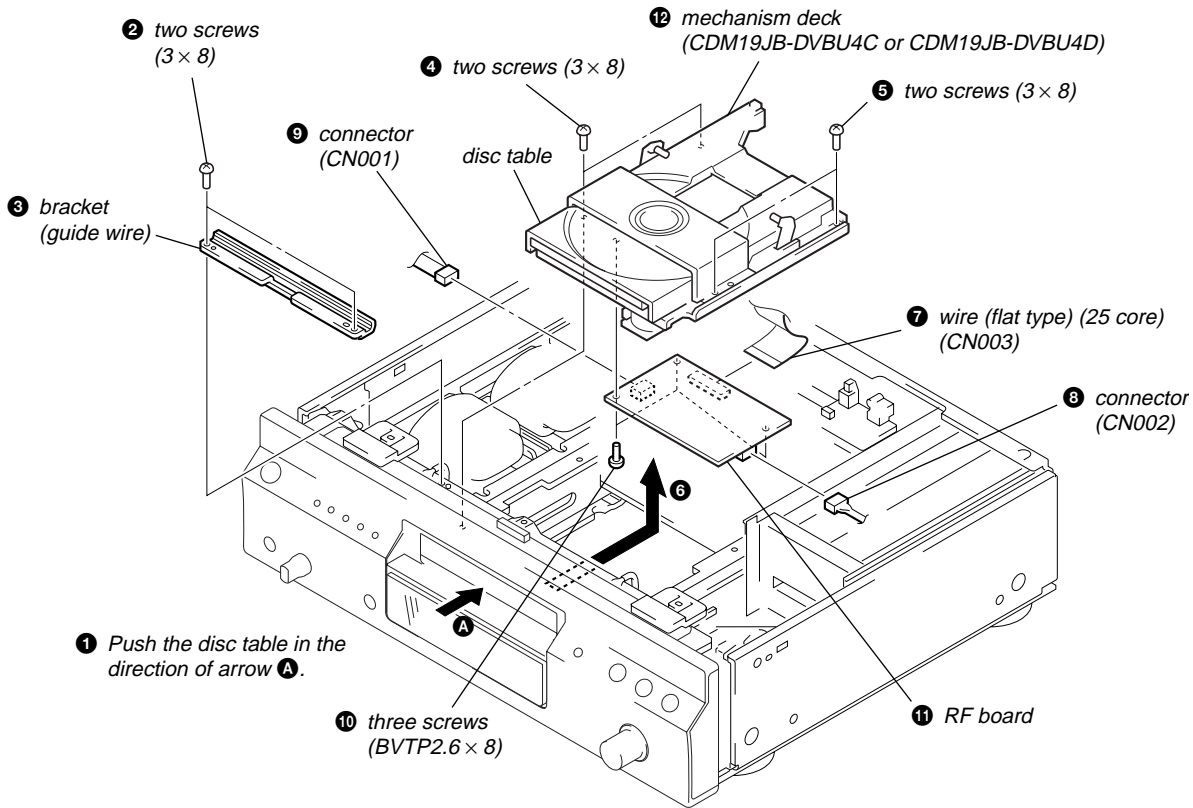

3-7. DISC TABLE, BELT, LOADING MOTOR (M1)

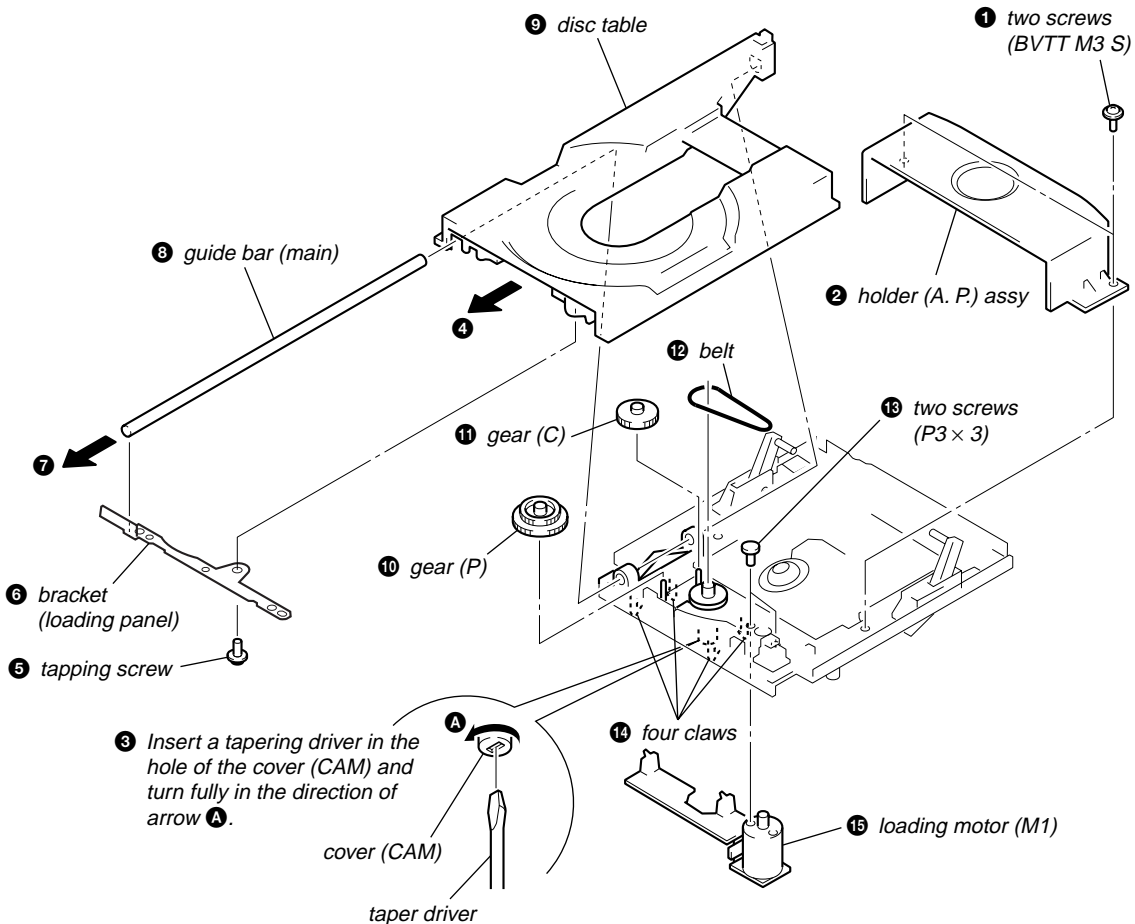

3-8. OPTICAL PICK-UP (KHM-230AAA)

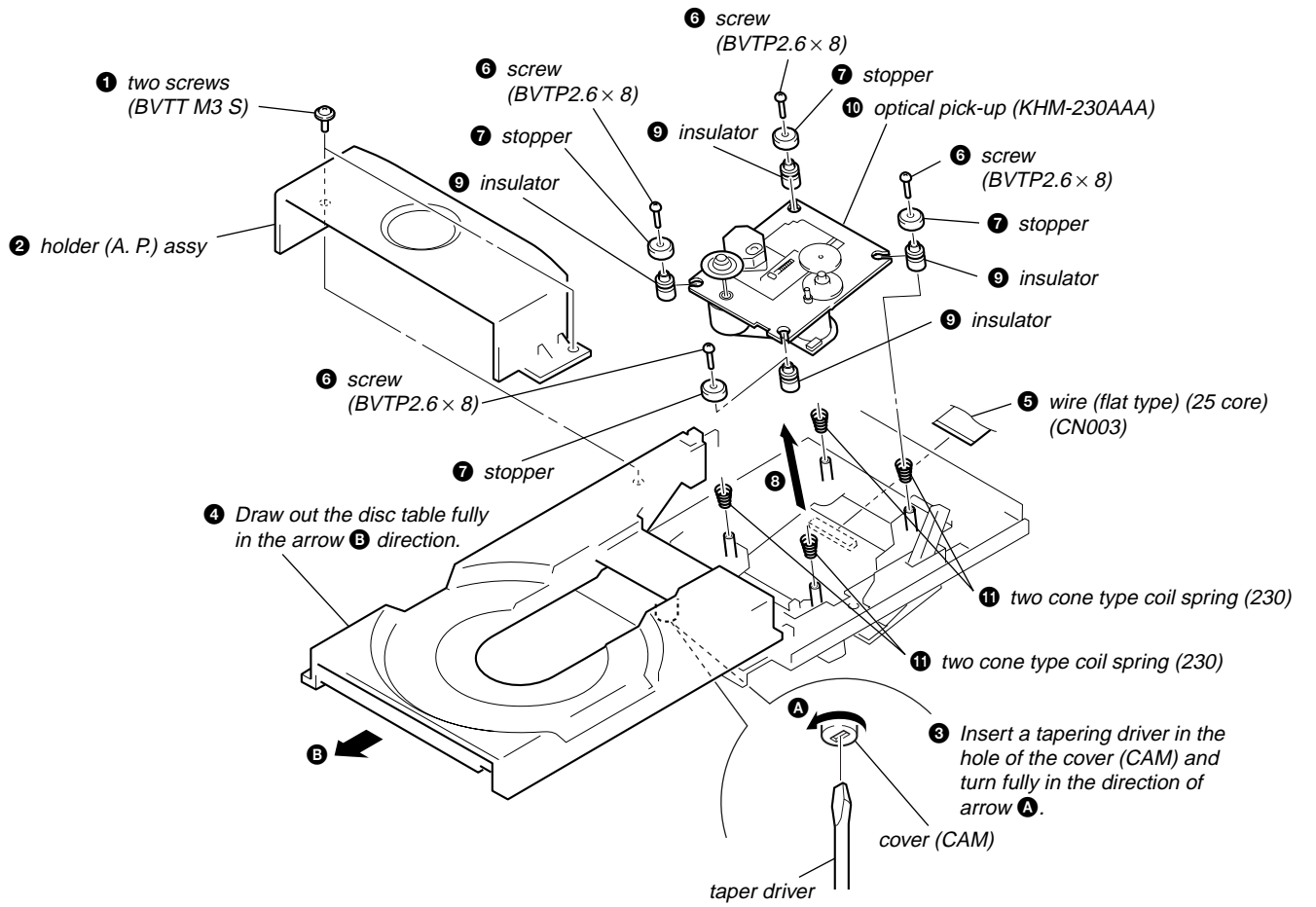

3-9. BASE UNIT (DVBU4C or DVBU4D)

DVBU4C: Except AEP (Silver type)

DVBU4D: AEP (Silver type)

- 7 Insert a taper driver into the cover (CAM), and rotate in the arrow B direction to raise the base unit (DVBU4C or DVBU4D) in the arrow C direction. (Chuck release state)

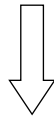
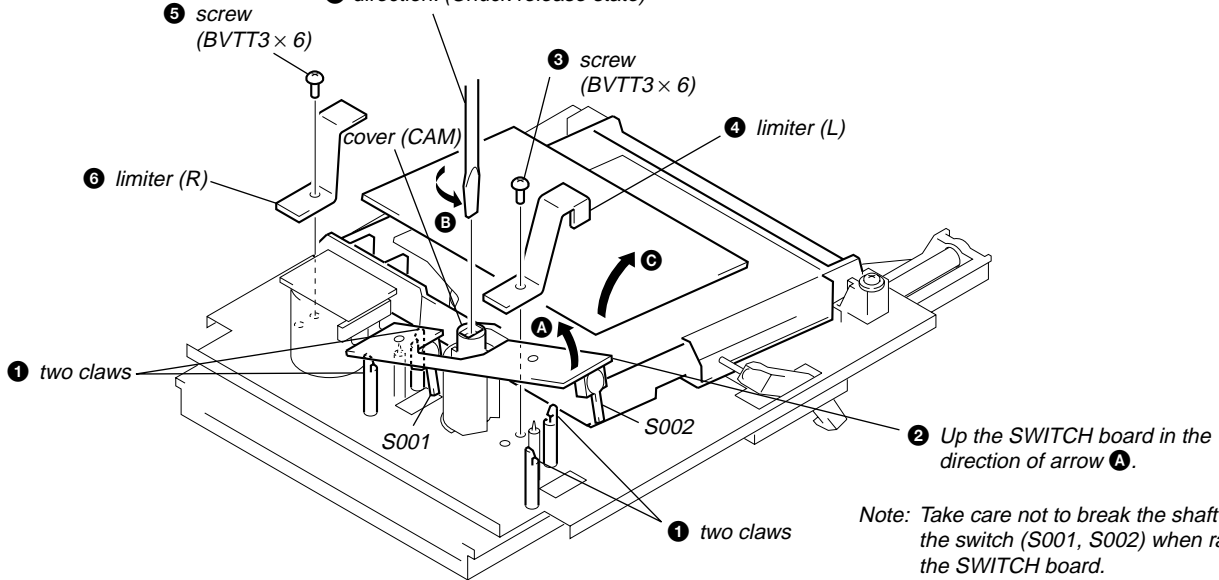

- 9 Raising the stable lock (L/R) assy simultaneously in the arrow D direction, remove the base unit (DVBU4C or DVBU4D) from the chassis (outseat).

Note: The stable lock (L/R) assy will attempt to return in the reverse direction of arrow D by a spring force. Therefore, take care not to break the shaft of stable lock (L/R) assy when removing the stable lock (L/R) assy from the base unit (DVBU4C or DVBU4D).

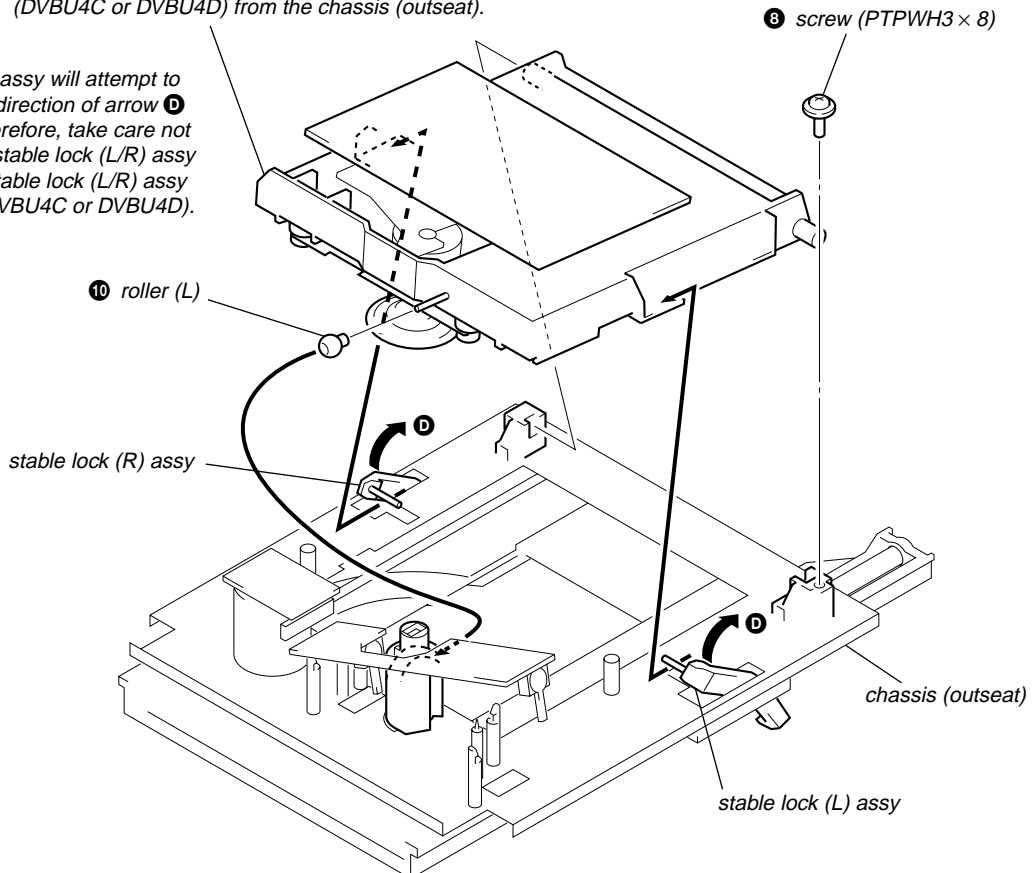

SECTION 4 TEST MODE

In this set, various checks are automatically performed by executing the commands in the test mode.

Note: This set makes adjustment every optical pick-up and stores its result in the EEPROM (IC903) on the MAIN board. Accordingly, if a combination of optical pick-up and EEPROM is changed, be sure to perform 4-3. SET CHECK. Also, perform 4-1. IC INTERFACE CHECK, 4-2. DISPLAY CHECK, and 4-6. WAVEFORMS CHECK.

Disc for Test Mode

Various checks of this set require the following discs.

Model	Type *1	Category	Application
MODEL SATD-S5 (J-2501-215-A) SATD-S4 (J-2501-184-A)	SL	12 cm disc Reference disc	Adjusted value check, Operation check, Optical waveform check
Not specified	DL	12 cm disc	Operation check
PATD-012 (4-225-203-01) YEDS-18 (3-702-101-01)	CD	12 cm disc Reference disc	Adjusted value check, Operation check, Optical waveform check
Not specified	HYBRID	12 cm disc	Operation check

*1 SL: Single Layer
DL: Dual Layer

Test Mode Command List

The contents of test mode are as follows.

Note: Wrong operation in the test mode causes a trouble, thus requiring extreme care.

LINE command (0X): Use mainly for a manufacturing line.

No.	Name	Description	Remarks
00	RFAMP Read	Each register set value of the IC001 (RF AMP) is displayed via RS-232C	Not used for the servicing
05	DSP MON1	XUGF, XPCK, C2PO outputted from IC509 (CD DSP)	Not used for the servicing
06	DSP MON2	MNT0, MNT1, MNT2, MNT3 outputted from IC509 (CD DSP)	Not used for the servicing
07	DSP MON3	RFCK, XPCK, XROF, GTOP outputted from IC509 (CD DSP)	Electrical measurement, CD CLV jitter measurement

STANDARD command (1X): Use when the servo is applied by manual operation.

No.	Name	Description	Remarks
12	LD ON/OFF	The laser diode is turned on or off	On or off are switched alternately
13	SPIN ON/OFF	The spindle motor is rotated with the regulated voltage	On or off are switched alternately
14	FSRV ON/OFF	The focus servo is turned on or off	On or off are switched alternately
15	TSRV ON/OFF	The tracking servo is turned on or off	On or off are switched alternately
16	CLV ON/OFF	The spindle SLV servo is turned on or off Focus and tracking servos must be already turned on	On or off are switched alternately
17	SSRV ON/OFF	The sled servo is turned on or off Focus, tracking and spindle servos must be already turned on	On or off are switched alternately
18	ALL SRV ON	All servos are turned on	
19	ALL SRV OFF	All servos are turned off	Stop command in the test mode

FOCUS command (2X): Focus related. (All servos must be already turned on (except command 21))

No.	Name	Description	Remarks
21	FSRCH ON/OFF	The continuous vertical motion of the optical pick-up lens is turned on or off	Avoid a long-time use On or off are switched alternately
22	F-BIAS UP	Increase focus bias	Focus bias value
23	F-BIAS DOWN	Decrease focus bias	Focus bias value
24	ADJ FCSBIAS	The focus bias is adjusted automatically Both + and - directions are searched to search for best jitter point	
25	FGAIN UP/DW	The focus servo gain is switched between normal and down	Normal or down are switched alternately
27	FOCUS AGC	The focus servo gain is adjusted automatically	

OFFSET (PI, FE, TE) command (3X): Adjusts the offset of PI, FE and TE signals.

No.	Name	Description	Remarks
31	PI/FE OFSET	Adjusts the offset of PI, FE and TE signals This adjustment must be executed after 61 DISC DETECT	TE offset adjustment is executed for the CD only

Setting Method of Test Mode

Turn the [POWER] button on while pressing the [◀◀AMS▶▶] dial and the [MENU] button. Release the [MENU] button and the [◀◀AMS▶▶] dial in this order when "DIAG MODE" is displayed on the fluorescent indicator tube.

Releasing Method of Test Mode

To release the test mode, turn the [POWER] switch off.

Selection/Entry of Test Mode

To select and enter the "DIAG MODE", operate as follows.

1. Rotate the [◀◀AMS▶▶] dial to select the menu, and press the [◀◀AMS▶▶] dial to enter.
2. The test is switched on or off alternately each time the [◀◀AMS▶▶] dial is pressed.
3. To return to the previous step, rotate the [◀◀AMS▶▶] dial to select the desired item, and press the [◀◀AMS▶▶] dial to enter.

SCD-XA9000ES

TRACKING command (4X): Tracking servo related.

No.	Name	Description	Remarks
41	TGAIN NM/UP	The tracking servo gain is switched between normal and up	Normal or up are switched alternately
44	ADJ TRK DSP	The traverse AGC and E-F balance adjustment is performed	
45	TRACKING AGC	The tracking servo gain is adjusted automatically	

SEARCH command (5X): Track search related. (Nos. 51 through 53 are not used for the servicing.)

No.	Name	Description	Remarks
51	1-TRCK JUMP	One-track jump is performed	
52	FINE SEARCH	Fine search is performed	
53	M-TRCK MOVE	M-track movement is performed	

DISC DETECT command (6X): Disc type check related.

No.	Name	Description	Remarks
61	DISC DETECT	Disc type check is executed Display after judgment DSKMOD CD: Judged as CD DSKMOD SL: Judged as SACD (SL) DSKMOD DL: Judged as SACD (DL) DSKMOD HYB: Judged as HYBRID	Refer to how to apply servo by manual operation (See page 21)
62	CD SETTING	Enter disc type CD setting	CD forced setting
63	SL SETTING	Enter disc type SL setting	SL forced setting
64	DL SETTING	Enter disc type DL setting	DL forced setting
6F	Download		Not used for the servicing

LASER command (7X): Laser of optical pick-up related.

No.	Name	Description	Remarks
7A	ADDTIME CD	Cumulative light emission time of the laser for CD is displayed (Initialized by 8D command)	
7B	ADDTIME HD	Cumulative light emission time of the laser for SACD is displayed (Initialized by 8D command)	
7C	FJUMP TEST		Not used for the servicing

TOOLS command (8X): Performs aging, reads adjusting parameters, etc.

No.	Name	Description	Remarks
81	VERSION	Firmware version is displayed	Example: Ver 1.00
83	TRAY AGING	Tray open-close aging is performed	Not used for the servicing
87	DISP ADJ DT	Automatic adjusting parameters are displayed via RS-232C	Not used for the servicing
8D	SETUP MODE	Set to factory shipping mode PLAY MODE, etc. are initialized (AEP model only)	Set when repair completed Refer to 4-5. SHIPPING MODE (See page 24)
8F	SETUP U/CA	Set to factory shipping mode PLAY MODE, etc. are initialized (US and Canadian models only)	Set when repair completed Refer to 4-5. SHIPPING MODE (See page 24)

QA command (9X)

No.	Name	Description	Remarks
91	FJUMP CHECK	The focus jump is checked	Not used for the servicing
92	SET CHECK	The set is checked	Refer to 4-3. SET CHECK (See page 22)
93	WATER MARK		Not used for the servicing
94	SET AGING	The set aging is performed Repeat by the specified number of times or until an error occurred	Not used for the servicing
95	FJMP CHK BU	The focus jump is checked (for jig)	Not used for the servicing
9A	MIRR MES	MIRR signal offset measurement	Not used for the servicing
9C	BU DENCHO	The S curve waveform, traverse waveform, and RF waveform can be checked successively	Refer to 4-6. WAVEFORMS CHECK (See page 24)
9D	PLAY&RFD ON	SACD playback, RFD output SACD jitter measuring mode	Not used for the servicing
9E	RFD ON/OFF	RFD output is turned on or off SACD jitter measuring mode	Not used for the servicing

IC command (AX)

No.	Name	Description	Remarks
A0	IC SELF CHK	Each IC and its communication are checked	Normal or up are switched alternately

How to Apply Servo by Manual Operation

In analyzing failures of the set, the servo may be applied by manual operation. To apply servo in the test mode, use the following method.

1. After setting the test mode, rotate the **[◀◀ AMS ▶▶]** dial to select a command, and press the **[◀◀ AMS ▶▶]** dial to enter.
2. "61 DISC DETECT" (Disc type check)→"18 ALL SRV ON" (All servos on + auto adjustment)
3. If applying servo while checking the condition one by one, "61 DISC DETECT" (Disc type check)→"31 PI/FE OFFSET" (Offset automatic adjustment)→"14 FSRV ON/OFF" (Focus servo on)→"16 CLV ON/OFF" (CLV servo on)→"44 ADJ TRK DSP" (E-F balance adjustment)→"15 TSRV ON/OFF" (Tracking servo on)→"17 SSRV ON/OFF" (Sled servo on)→"24 ADJ FCSBIAS" (Focus bias adjustment)→"27 FOCUS AGC" (Focus auto gain adjustment)→"45 TRACKING AGC" (Tracking auto gain adjustment).

Note: 1. On and off are alternately switched in the same command.
 2. For a stop, select "19 ALL SRV OFF" and press the **[◀◀ AMS ▶▶]** dial.

4-1. IC INTERFACE CHECK

The communication between microcomputer and main ICs is checked.

Checking Method:

1. After setting the test mode, rotate the **[◀◀ AMS ▶▶]** dial to select "A0. IC SELF CHECK" and press the **[◀◀ AMS ▶▶]** dial to enter.
2. A checking will start automatically. (Checking time is about 3 seconds)
3. At successful completion of check, "IC CHECK OK" is displayed. In this case, no error exists in the IC interface.

Note: The check mentioned above tests the communication from microcomputer to main ICs. Even if the check successfully finished, the IC to be checked is not always normal. Consider it for reference only.

4. In case of an IC communication error, the following display will be given during the checking. Possible causes of error are as listed below.

Error display	Causes (typical example)
DVD DEC. ERROR	1. IC701 (SACD decoder) is faulty 2. IC701 pin ⑭ (XRST) does not go "H" • IC901 pin ⑩ (XDIS IO) does not go "H" • IC904 (PLD) is faulty 3. 768fs (33.8688 MHz) is not present to IC701 pin ⑮ (XTAL) • IC811 (3-multiplying circuit) is faulty • Clock signal 256fs is not sent from MOTHER board (CN702 pin ④) • CN702 pin ① (GND) and pin ③ (+3.3V-D) are open or shorted • CN701, 702 and FFC connection is loose, or FFC is disconnected
DVD DRAM ERR	1. IC706 (D-RAM) is faulty 2. IC701 pin ⑭ (XRST) does not go "H" • IC901 pin ⑩ (XDIS IO) does not go "H" • IC904 (PLD) is faulty 3. Faulty communication line between IC701 and IC706 • Data line, address line, WE, etc. 4. D903 (1SS367) is faulty D+3.3V is not present to IC706
CD DSP ERROR	1. IC509 (CD DSP) is faulty 2. 768fs (33.8688 MHz) is not present to IC509 pin ⑦ (XTAL) Same as cause 3 of DVD DEC. ERROR 3. IC509 pin ② (XRST) does not go "H" • IC901 pin ⑩ (XDIS IO) does not go "H" • IC904 (PLD) is faulty

Error display	Causes (typical example)
EEPROM ERROR	1. IC903 (EEPROM) is faulty
SAMBA DRAM ERR (DSD decoder is also checked)	1. IC808 (D-RAM) is faulty 2. IC801 (DSD decoder) is faulty 3. 768fs (33.8688 MHz) is not present to IC801 pin ⑩ (MCKI) Same as cause 3 of DVD DEC. ERROR 4. IC801 pin ⑨ (XRST) does not go "H" • IC901 pin ⑩ (XDIS IO) does not go "H" • IC904 (PLD) is faulty 5. Faulty communication line between IC801 and IC808 • Data line, address line, WE, etc. 6. D904 (1SS367) is faulty D+3.3V is not present to IC808
RF AMP ERROR	1. IC001 (RF AMP) is faulty 2. Loose connection between CN708 on MAIN board and CN005 on RF board, or FFC disconnection CN708 pin ⑨ (CLK RF), pin ⑳ (DATA RF) and pin ㉑ (SDEN) must be checked
SD BUS ERROR	1. IC701 SD bus and IC801 AV decoder interface is faulty 2. IC812 to 814 are faulty
AUDY ERROR	1. IC802 and IC803 (SD-RAM) are faulty 2. Faulty communication line between IC802 and IC901 3. Faulty communication line between IC802 and IC803 (SD-RAM)

Causes Common to Each IC:

1. Faulty communication line between microcomputer and each IC.
 Disconnected patterns, floating series resistors, bridge, etc.
 2. Faulty IC supply voltage.
 Particularly, check D+3.3V voltage.
 3. Faulty microcomputer communication port to each IC
- Note:** In case of more than two errors, the error display is switched over one after another, thus making the reading difficult.
 In such a case, press again the **[◀◀ AMS ▶▶]** dial to make a recheck for error reading.

4-2. DISPLAY CHECK

Checking Method:

1. Short the BP (TEST MODE) on the DISPLAY board, then press the **[POWER]** button to turn on the power.
2. All segments of fluorescent indicator tube will automatically light up, and therefore check that there is no chipped character.
3. The "Remocon Check" will be displayed after the segment check finished successfully, then press a proper key on the remote commander and therefore check that there is reaction to remote commander.
4. After "Key&Led Check" is displayed, press the key on the display one by one. If all key on the display is pressed, LED and segments of fluorescent indicator tube except numbers of calendar will light up, then "Jog Dial-Check" will be displayed.
5. After "Jog-Dial Check" is displayed, the numbers of calendar will be displayed from 1 to 15 each time the **[◀◀ AMS ▶▶]** dial is rotated clockwise.
6. After display up to 15, the numbers of calendar will disappear in order each time the **[◀◀ AMS ▶▶]** dial is rotated counterclockwise.
7. "!!%TEST-END!!%" will be blinked when all are cleared, and display check is completed.

4-3. SET CHECK (AUTOMATIC VARIOUS MEASUREMENTS)

The operational stability of the set is checked. The check and OK/NG judgment are performed automatically.

Note: In the set check using the CD, besides a checking, the MIRR time used for the disc check is measured every optical pick-up, and from the measured result, the threshold value is calculated and it is stored in the EEPROM (IC903) on the MAIN board. Accordingly, if a combination of optical pick-up and EEPROM is changed (for example, the optical pick-up or MAIN board is replaced), be sure to perform the set check using the following CD. As the data stored in the EEPROM are overwritten every set check, retry if failed. For the set check using the SACD, only checking is made.

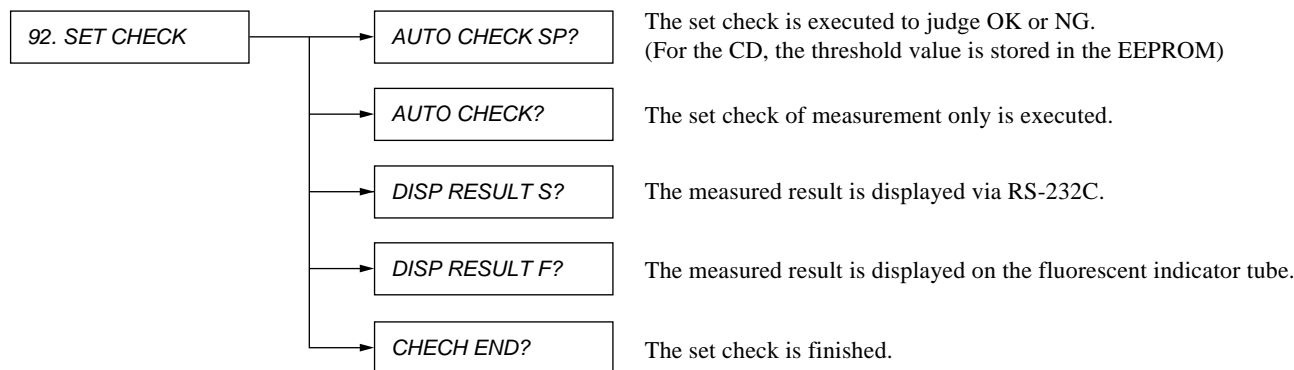

CD and SACD (SL) Disc Operation Check

Checking method:

1. After setting the test mode, rotate the [◀◀AMS▶▶] dial to select “SET CHECK” and press the [◀◀AMS▶▶] dial to enter.
2. Upon display of “AUTO CHECK SP?”, further press the [◀◀AMS▶▶] dial.
3. The tray will open automatically, and then set the test disc*1 of CD or SACD.
4. With the “DISC IN&JOG ON” displayed, press the [◀◀AMS▶▶] dial, and the check will be executed automatically.
5. “SPEC OK!” will be displayed if the measured result is within the specification. Faulty item name and the measured result will be displayed if any measured item is NG.
6. After that, “AUTO CHECK SP?” will be again displayed, and then rotate the [◀◀AMS▶▶] dial to select “CHECK END?”. Further, press the [◀◀AMS▶▶] dial, and the test mode selection display will be back, and then press the [OPEN/CLOSE] button and take the test disc out.

*1 Use PATD-012 or YEDS-18 for CD, and SATD-S5 or SATD-S4 for SACD (SL). Using another disc will result in a checking failure.

Measured Items:

Items	Description	Remarks
RF/VC/FE/TE (ORG)	Offset values before RF (PI), VC, FE, TE signal offset adjustment RF (8 bit data in hex notation) VC, FE, TE (9 bit data in hex notation)	At offset 0 RF: A0h VC, FE, TE: 00h
RF/VC/FE/TE (ADJ)	Offset values after RF (PI), VC, FE, TE signal offset adjustment (Less than ORG value if offset correction is normal) RF (8 bit data in hex notation) VC, FE, TE (9 bit data in hex notation)	VC offset is not adjusted (Measurement only) Also, for SACD, the TE offset is not measured and adjusted
PI/TRVS PP (ORG/ADJ)	PI (ORG): PI value at disc type check (decimal data) PI (ADJ): PI value after PI offset adjustment (read value at microcomputer A/D) (decimal data) TRVS PP (ORG): Traverse level before level correction (AGC) (decimal data) TRVS PP (ADJ): Traverse level after level correction (AGC) (decimal data)	PI level conversion Read value × 12.9mV Traverse level conversion Read value × 12.9mV 12.9mV=3.3V ÷ 256 (8 bit)
PIOR/CCR/TRCR	PIOR: Set value of PI offset coarse adjusting register CCR: Set value of FE offset coarse adjusting register TRCR: Set value of TE offset coarse adjusting register	Registers in RF amplifier
FOCUS/TRK GAIN	Auto gain adjusted values of focus and tracking servos (8 bit data in hex notation)	
FBIAS/TRVSC/TRCR2/CFR	FBIAS: Focus bias set value (9 bit data in hex notation) TRVSC: Traverse center value (9 bit data in hex notation) TRCR2: Set value of E-F balance coarse adjusting register CFR: Set value of traverse level adjusting register	TRCR2 adjusts the E-F gain balance and used for CD only (Fixed to 06 for SACD) TRCR2 and CFR are registers in RF amplifier
PSP AMPLITUDE		SACD only
1-LAST TRK SEEK (msec)	Average seek time from first track to last track of disc	
ERROR RATE	Error rate measurement For CD: Average value/Maximum value of C1 and C2 For SACD: Average value/Maximum value of PO, PI1 and PI2	For the CD, Measure for 7 sec at track No.5 For the SACD, calculation from 100-block data at track No.5

Specified Value:

Specified value used for OK/NG judgment when executing 92. SET CHECK→AUTO CHECK SP?

Measured Items		Specified value	
RF AVRG (ADJ)		8Ch to ABh	
VC AVRG (ADJ)		1F7h to 09h	
FE AVRG (ADJ)	(1) CD	1EEh to 12h	
	(2) SACD	1F1h to 0Fh	
TE AVRG (ADJ)		1E2h to 1Eh	
TRVS PP (ADJ)		45h to 73h	
FCS GAIN		10h to 60h	
TRK GAIN		10h to 60h	
ERROR RATE	(1) CD	C1	20 or less
		C2	0
	(2) SACD	PII NUM	100 or less
		PII FRAME	5 or less
PSP AMPLITUDE (SACD only)		1000 to 4000	
1-LAST TRK SEK		3500 or less	

Note: The specified values attached with “h” are hexadecimal numbers, and others are decimal numbers.

RF, VC, FE, and TE measured values are hexadecimal data with positive and negative signs. When comparing the measured value with the specified value, refer to the following.

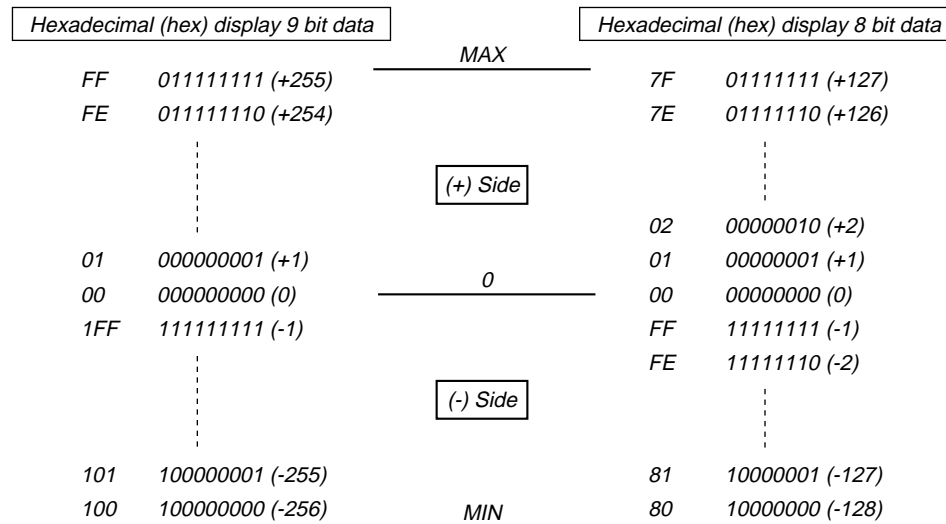

4-4. SACD (DL) DISC OPERATION CHECK

(• Perform as necessary)

This checking performs the focus jump using a DL disc, which is a dual-layer HD disc, to verify the stability of the set.

A set of layer 0 most-outside track access (only once)→one-second trace→focus jump (layer 0→1)→one-second trace→focus jump (layer 1→0) are repeated 5 times.

Checking Method:

1. After setting the test mode, rotate the **◀◀AMS▶▶** dial to select "91 FJUMP CHECK" and press the **◀◀AMS▶▶** dial to enter.
2. The tray will open automatically, and then set the DL disc.
3. With "DISC IN&JOG ON" displayed, press the **◀◀AMS▶▶** dial.
4. The tray will be loaded in automatically, and then the test will start.
5. During the test, "NOW TEST>>>>" is displayed.
6. Upon successful completion of the check, "OK!" will be displayed and the tray will open automatically. (In case of NG, "NG! ERR FJ-UP" or "NG! ERR FJ-DWN" is displayed)
7. Take the DL disc out and press the **OPEN/CLOSE** button, and the test mode selection display will be back

4-5. SHIPPING MODE

The repaired set must be initialized, and for this purpose the set should be set to the shipping mode.

Setting Method:

1. After setting the test mode, rotate the **◀◀AMS▶▶** dial to select "8D SETUP MODE" (AEP model) or "8F SETUP U/CA" (US and Canadian models) and press the **◀◀AMS▶▶** dial to enter.
2. "INITIAL OK" is displayed and the test mode selection display will be back immediately.
3. Press the **POWER** button to turn the power off.

The following setups are established in the shipping mode

1. Initialization of EEPROM (IC903)
 - LAYER SELECT SACD
 - M/2CH SELECT MULTI
 - 2ch SPK MODE 2ch DIRECT
 - Mch SPK MODE Mch DIRECT
 - REPEAT MODE REPEAT OFF
 - LANGUAGE ENGLISH
 - DIGIFIL MODE STANDARD
 - D.OUT ON
 - SPK DISTANCE 3.0 meter/10 feet at each channel meter (AEP model)/ feet (US and Canadian models)
 - SPK DIST.UNIT
 - i.LINK POWER OFF
 - i.LINK (FUNCTION) OFF
 - Resetting the cumulative light emission time of the laser

Note: Even if the shipment mode setting mentioned above is made, the disc check threshold value attained in the 3. SET CHECK is not cleared.

2. The optical pick-up moves to the home position (most-inside track)

Error List

Display	Description
Toc Error *	Error during the time from auto adjustment to TOC reading, Different type of disc (Such as a DVD disc), Disc is dirty
Toc Error ****	Illegal SACD (Such as a pirated version)

4-6. WAVEFORMS CHECK

BU Electrical Adjustment Mode

The BU electrical adjustment mode is used to check the S curve waveform, traverse waveform, RF waveform, and CLV jitter. After a disc is placed on the tray, each time the **◀◀AMS▶▶** dial is pressed, the check mode is switched in order for S curve waveform→traverse waveform→RF waveform→CLV jitter (for the CD).

S Curve Check

Connection:

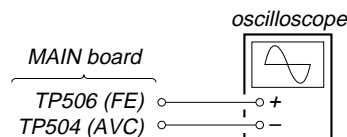

Checking Method:

1. After setting the test mode, rotate the **◀◀AMS▶▶** dial to select "9C. BU DENCHO" and press the **OPEN/CLOSE** button. Place the test disc (PATD-012 or YEDS-18 or SATD-S5 or SATD-S4) on the tray and close the tray, then press the **◀◀AMS▶▶** dial.
 2. At the completion of disc type check, "CD DETECT" will be displayed (for PATD-012 or YEDS-18).
- Note:** For the SATD-S5 or SATD-S4, "SL DETECT" is displayed.
3. Press again the **◀◀AMS▶▶** dial, and the S curve waveform check mode will become active and "S-CURVE MODE" will be displayed.
 4. Connect an oscilloscope to the TP506 (FE) and TP504 (AVC) on the MAIN board.
 5. Check that the level **(A)** and **(B)** of waveform on the oscilloscope satisfy the specification.

Specified Value:

Disc	(A)	(B)
SATD-S5 or SATD-S4	0.7 to 1.7 Vp-p	-0.1 to +0.1V
PATD-012 or YEDS-18		

S curve waveform

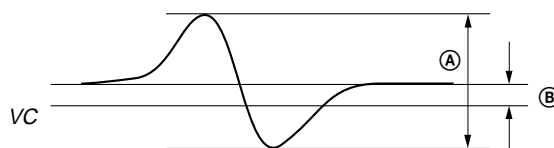

Note: For easier observation of this waveform, extend the sweep time and raise the brightness.

Checking and Connecting Location : See page 25.

Traverse Check
Connection:

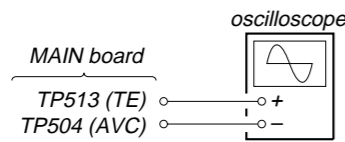

Checking Method:

- Under the condition of S curve waveform check mode in step 5, press the [AMS] dial.
- After "WAIT" is displayed, the traverse waveform check mode will become active and "TRV MODE ON" will be displayed.
- Connect an oscilloscope to the TP513 (TE) and TP504 (AVC) on the MAIN board.
- Check that the level (A) and (B) of waveform on the oscilloscope satisfy the specification.

Specified Value:

Disc	(A)	(B)
SATD-S5 or SATD-S4	0.9 to 1.4 Vp-p	-0.1 to +0.1V
PATD-012 or YEDS-18		

Traverse waveform

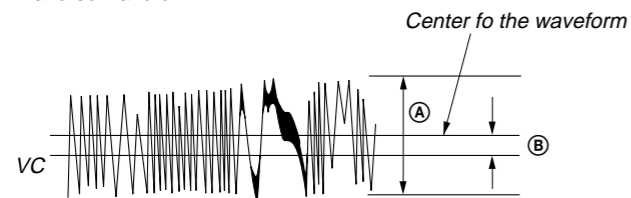

Checking and Connecting Location : MAIN Board

RF Level Check
Connection:

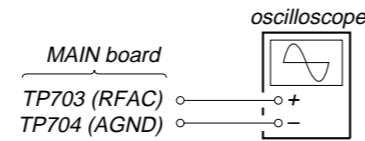

Checking Method:

- Under the condition of traverse waveform check mode in step 4, press the [AMS] dial.
- Connect an oscilloscope to the TP703 (RFAC) and TP704 (AGND) on the MAIN board.
- After "WAIT" is displayed, the RF waveform check mode will become active and "PLAY 5th TRACK" (for the SACD, "RF MODE ON") will be displayed, and the 5th music on the disc will be played.
- Check that the RF waveform is clear and the level satisfies the specification.
- Press the [AMS] dial (for the SACD, "RF JITTER (5th)" will be displayed, and further press the AMS dial), and "OUTSIDE TRACK" will be displayed and the outward track of the disc will be played.
- Check that the RF waveform is clear and the level satisfies the specification.
- Press the [AMS] dial, and "INSIDE TRACK" will be displayed and the inward track of the disc will be played.
- Check that the RF waveform is clear and the level satisfies the specification.
- After checking, press the [AMS] dial, and the test is over when "BU MEASURE" is displayed.
- Press the [OPEN/CLOSE] button to open the tray, and remove the test disc.
- Using each type of disc, repeat from step 1 of S curve waveform check up to step 10 of RF level check.
- When the check is over, press the [POWER] button to turn the power off.

Note: Take care not to leave the test disc in the set.

Specified Value:

Disc	(A)
SATD-S5 or SATD-S4	0.9 to 1.4 Vp-p
PATD-012 or YEDS-18	

RF signal waveform

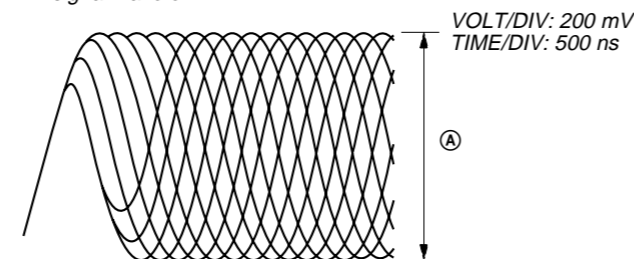

Note: Clear RF waveform refers to the waveform where ◊ shapes should be distinctively observed in the center.

Checking and Connecting Location : MAIN Board

CLV Jitter Check (CD only)
Connection:

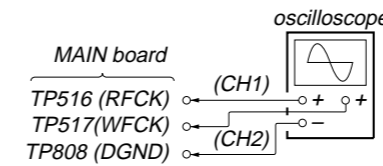

Checking Method:

- Under the condition of RF level check mode in step 3, connect the oscilloscope to the TP516 (RFCK) (CH1), TP517 (WFCK) (CH2), and the TP808 (DGND) (GND) on the MAIN board to check that the value (A) of the waveform satisfies the specification.

Note: Take care not to leave the test disc in the set.

Specified Value:

Disc	(A)
PATD-012 or YEDS-18	35 μsec or less

CLV jitter waveform

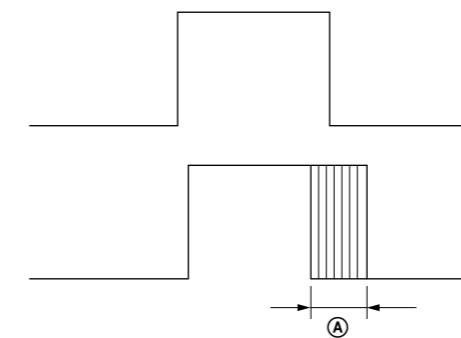

Checking and Connecting Location:

– MAIN Board (Component Side) –

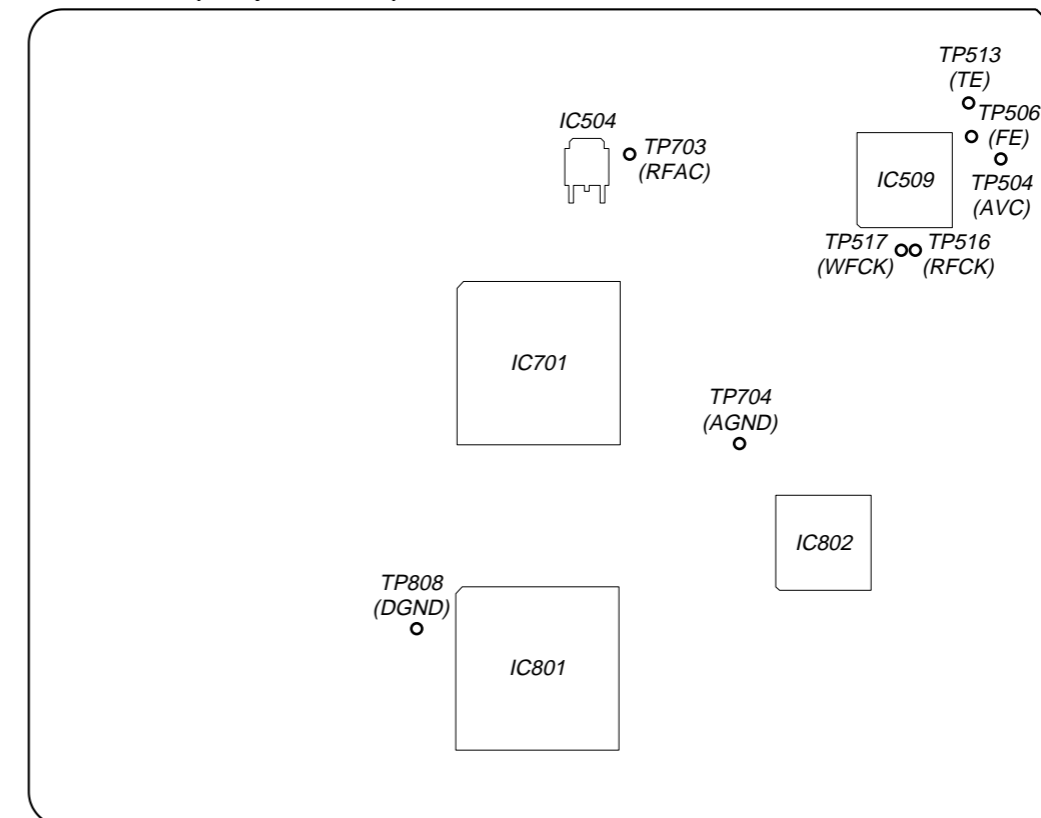

4-7. i.LINK SIGNAL OPERATION CHECK

Connect the set to a unit equipped with the i.LINK terminal to check if the bus reset occurs correctly. By this operation, a loose connection of the connector or a disconnection of the i.LINK cable can be checked.

Note: Do not perform the operation other than the specified operation in the following i.LINK test mode, as the set otherwise may not operate normally.

Checking Method:

- Press the [POWER] button to turn the power on, and rotate the [AMS] dial to select the "i.LINK" function (i.LINK LED (blue) lights up). Then, with the [TIME/TEXT] button kept pressed, press the [OPEN/CLOSE] button, [] button, and [] button in this order, so that the i.LINK test mode is activated and "<< [BACK] >>" is displayed on the fluorescent display tube.
 - With "<< [BACK] >>" displayed on the fluorescent display tube, rotate the [AMS] dial clockwise to advance the display by five steps, so that "B.Rst. [000]" is displayed. This counter increments by one or several counts each time the bus reset occurs.
 - Turn on the power of the unit equipped with the i.LINK terminal, and connect the set to the unit equipped with the i.LINK terminal using the i.LINK cable to check if the bus reset occurs correctly. If the bus reset does not occur, or if the bus reset occurs continuously, the i.LINK cable will be disconnected or the connector connection will be loose.
- Note:** The bus reset may not occur unless the power of the unit equipped with the i.LINK terminal is turned on when it is connected.
- With the set connected to the unit equipped with the i.LINK terminal using the i.LINK cable, move the i.LINK cable to check if the bus reset occurs. If the bus reset occurs though the i.LINK cable is not removed, the i.LINK cable will be disconnected or the connector connection will be loose.
 - Press the [POWER] button to turn the power off, or rotate the [AMS] dial counterclockwise so as to display "<< [BACK] >>", and then press the [MENU] button, so that the i.LINK test mode is deactivated.

SECTION 5
DIAGRAMS

5-1. BLOCK DIAGRAM – RF/SERVO Section –

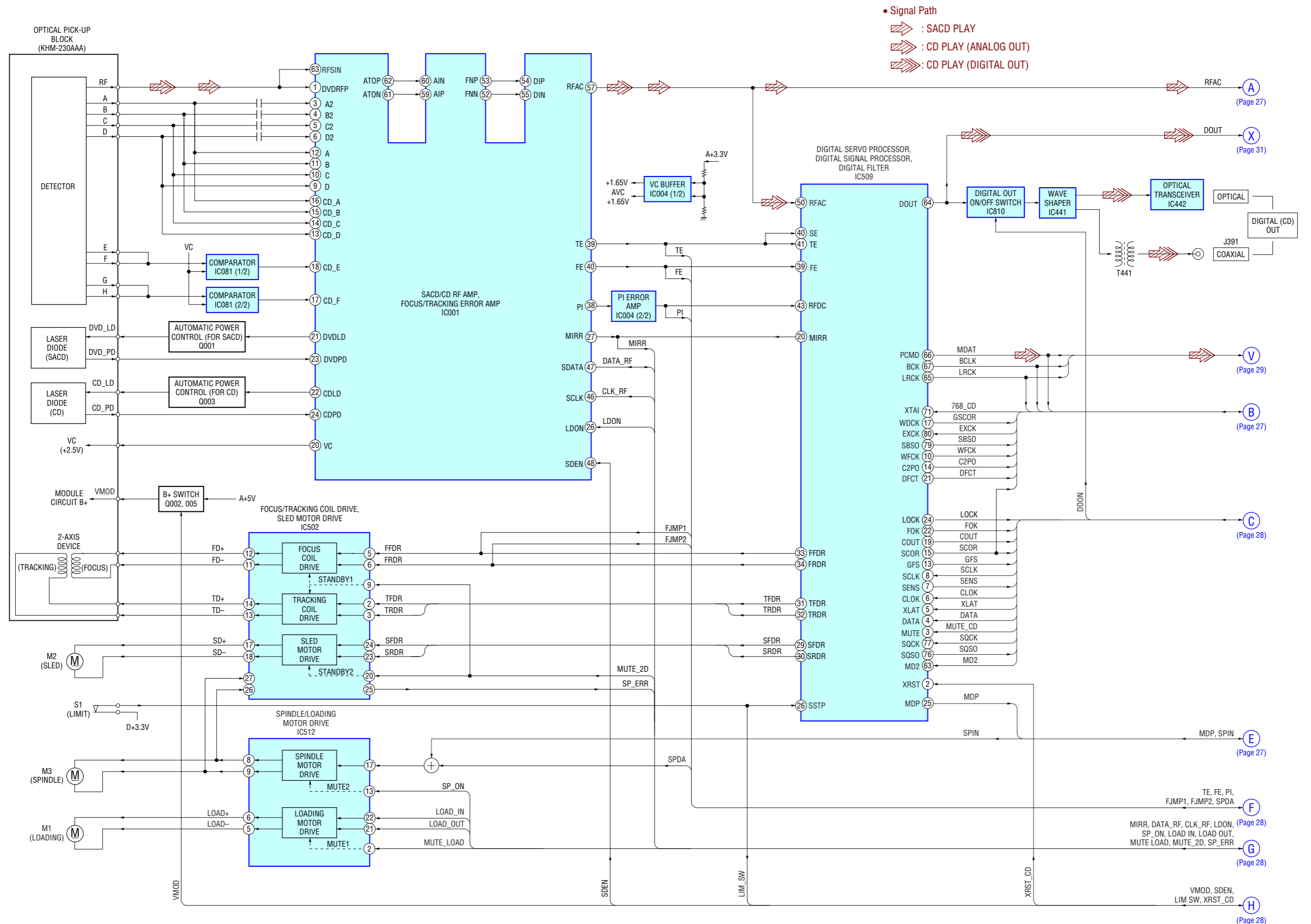

5-2. BLOCK DIAGRAM – MAIN Section (1/2) –

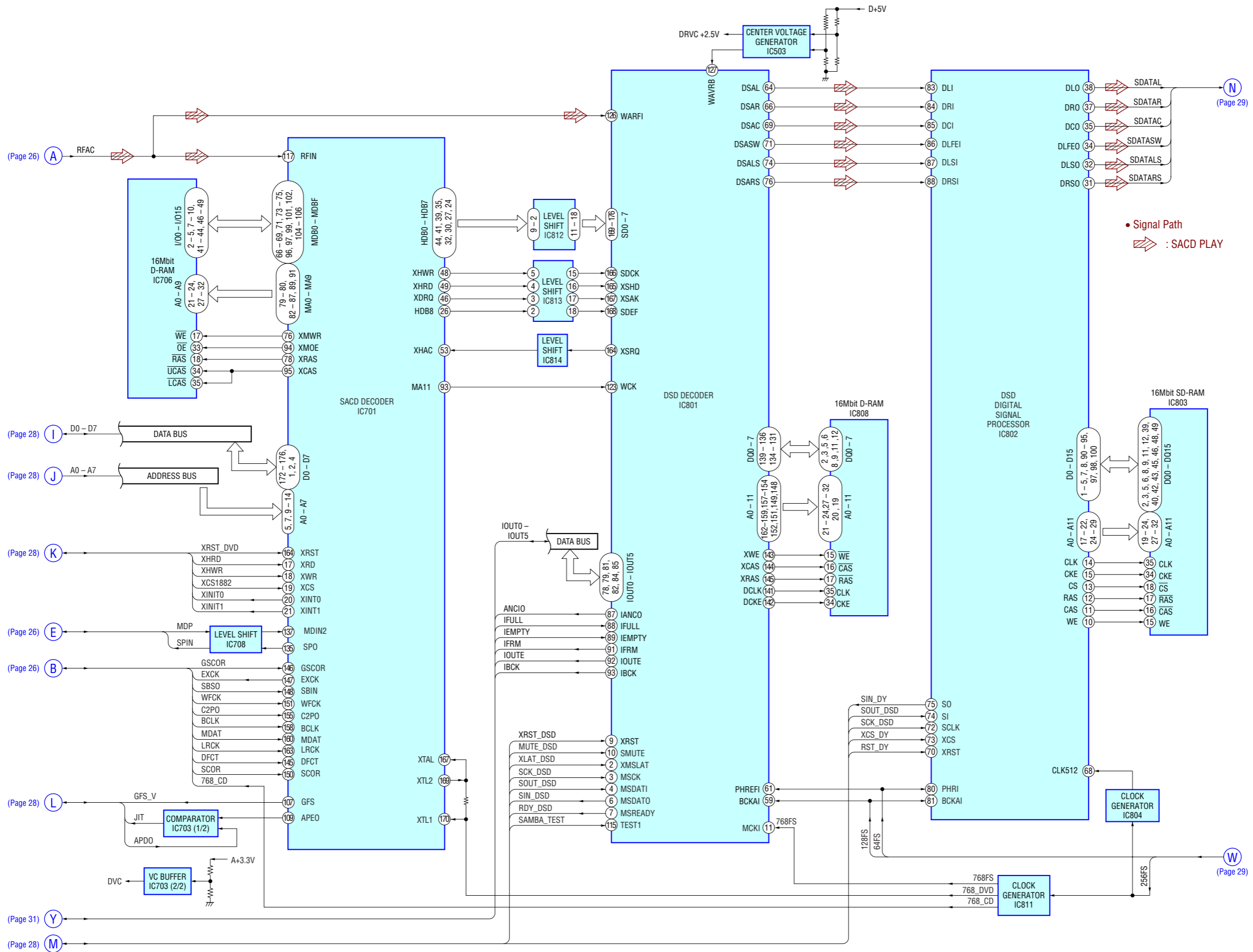

5-3. BLOCK DIAGRAM – MAIN Section (2/2) –

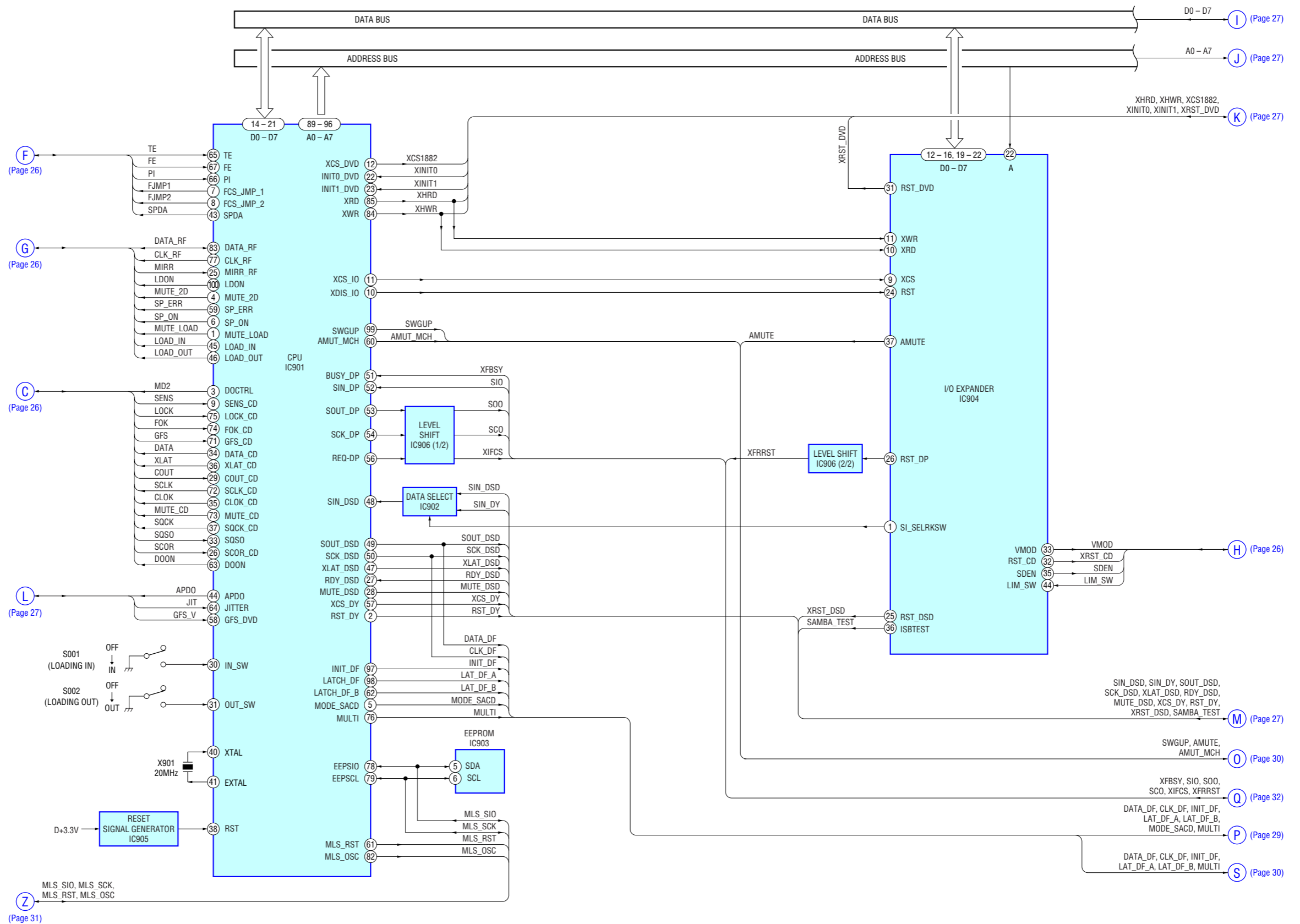

5-4. BLOCK DIAGRAM – AUDIO Section (1/2) –

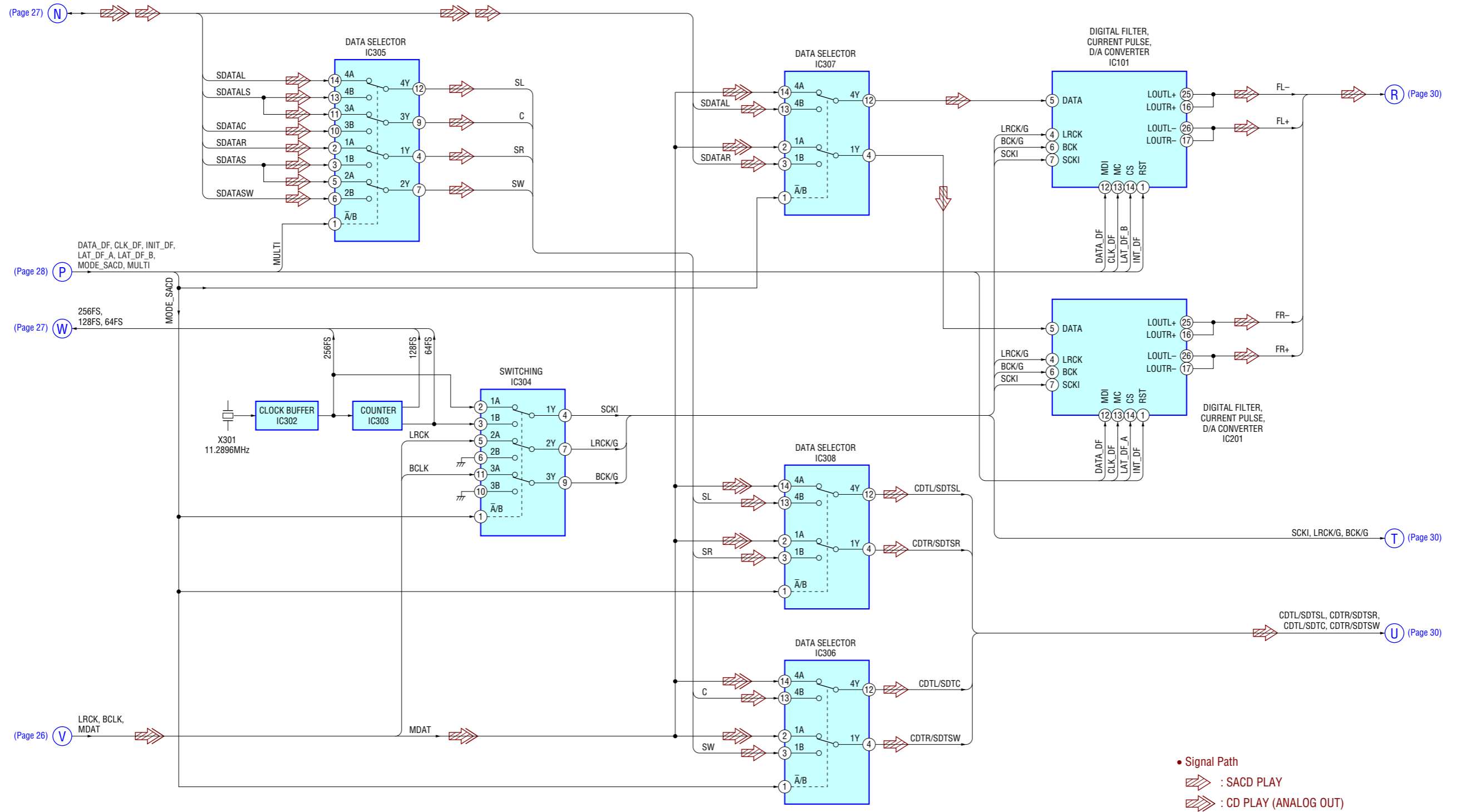

5-5. BLOCK DIAGRAM – AUDIO Section (2/2) –

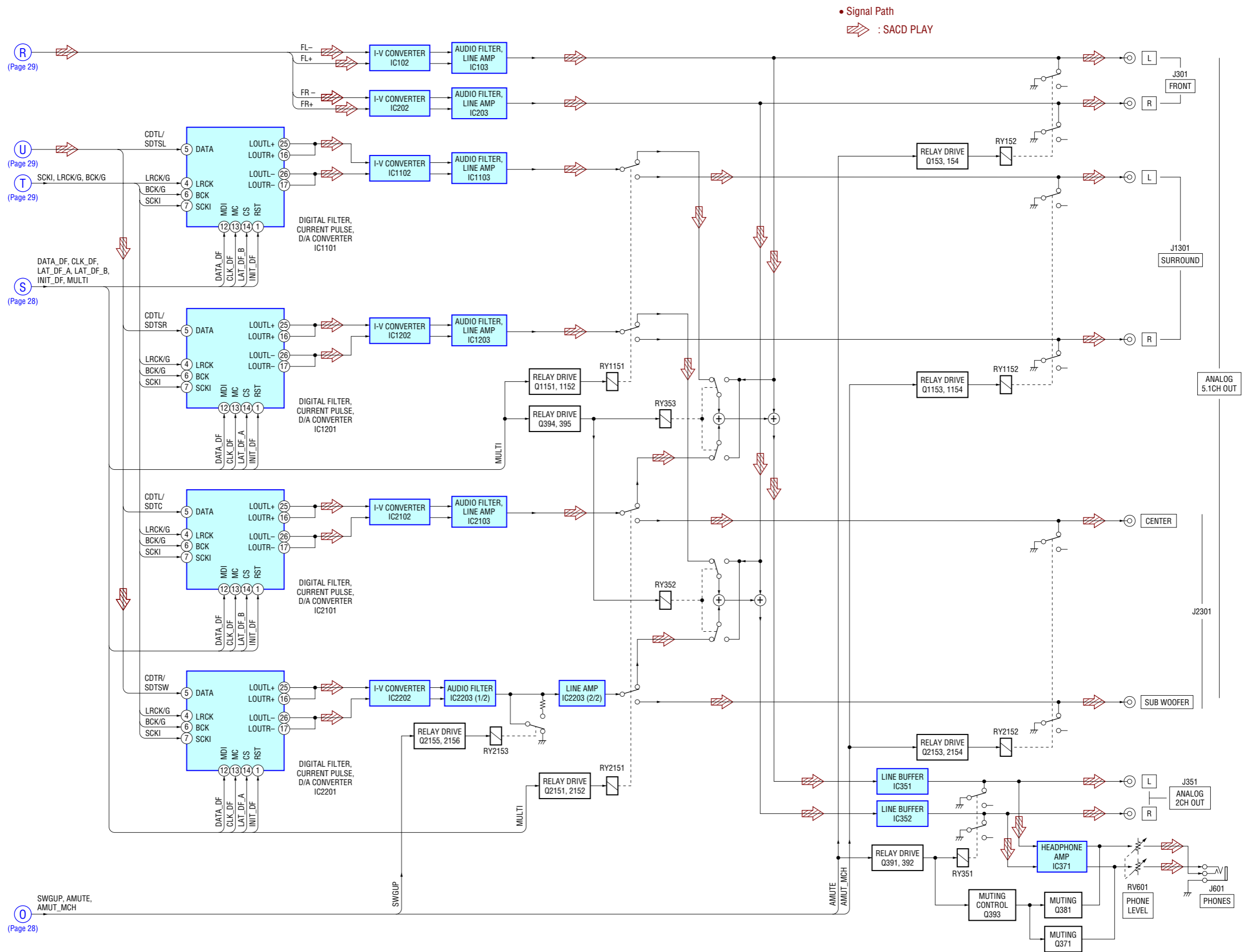

5-6. BLOCK DIAGRAM – LINK Section –

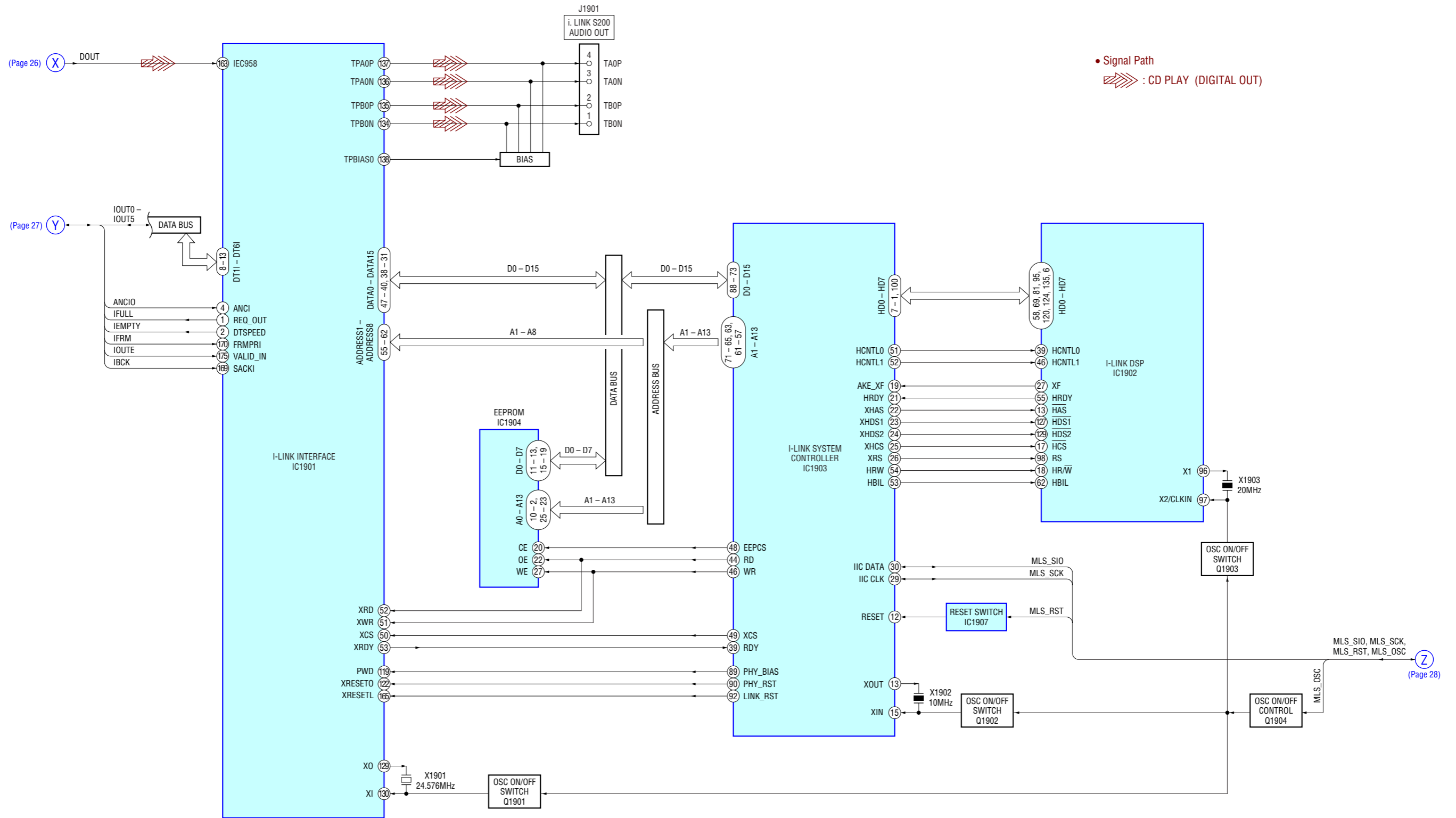

5-7. BLOCK DIAGRAM – PANEL/POWER SUPPLY Section –

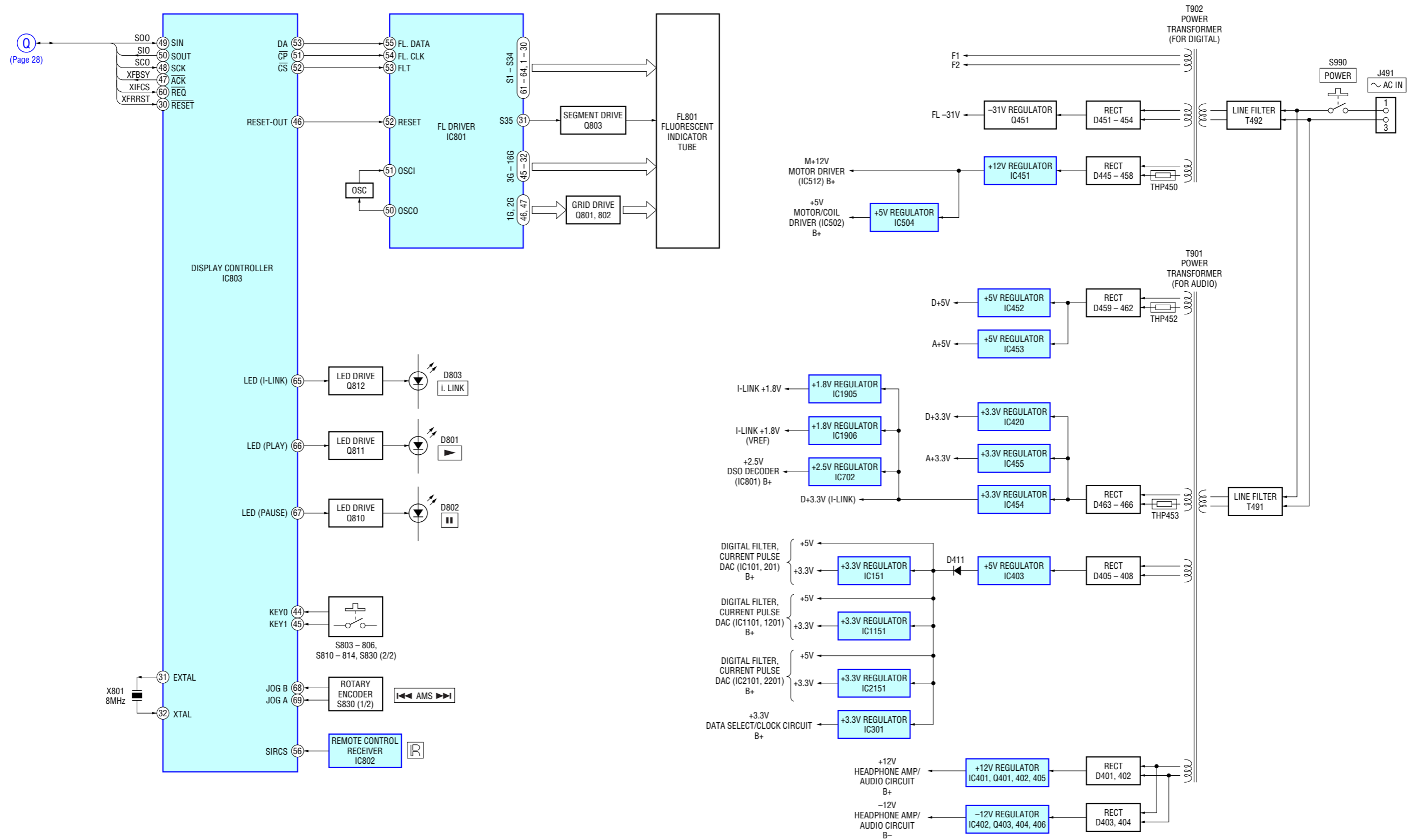

5-8. NOTE FOR PRINTED WIRING BOARDS AND SCHEMATIC DIAGRAMS

Note on Printed Wiring Board:

- : parts extracted from the component side.
- : parts extracted from the conductor side.
- : parts mounted on the conductor side.
- (green) : Pattern from the side which enables seeing. (The other layers' patterns are not indicated.)

Caution:
 Pattern face side: Parts on the pattern face side seen from the pattern face are indicated.
 (Conductor Side)
 Parts face side: Parts on the parts face side seen from the parts face are indicated.
 (Component Side)

Caution:
 Pattern face side: Parts on the pattern face side seen from the pattern face are indicated.
 (Side B)
 Parts face side: Parts on the parts face side seen from the parts face are indicated.
 (Side A)

- MAIN board and LINK board are multi-layer printed board. However, the patterns of intermediate-layer have not been included in diagram.
- Indication of transistor

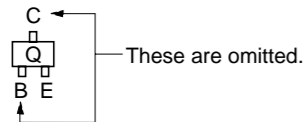

Note on Schematic Diagram:

- All capacitors are in μF unless otherwise noted. pF: $\mu\mu\text{F}$ 50 WV or less are not indicated except for electrolytics and tantalums.
- All resistors are in Ω and $1/4\text{W}$ or less unless otherwise specified.
- Δ : internal component.
- $\text{---}\text{---}\text{---}$: fusible resistor.
- $\text{---}\text{---}\text{---}$: panel designation.

Note:

The components identified by mark Δ or dotted line with mark Δ are critical for safety. Replace only with part number specified.

Note:

Les composants identifiés par une marque Δ sont critiques pour la sécurité. Ne les remplacer que par une pièce portant le numéro spécifié.

- $\text{---}\text{---}\text{---}$: B+ Line.
- $\text{---}\text{---}\text{---}$: B- Line.
- Voltages and waveforms are dc with respect to ground under no-signal conditions.
- no mark : CD PLAY
- () : SACD PLAY
- * : Impossible to measure
- Voltages are taken with a VOM (Input impedance 10 M Ω). Voltage variations may be noted due to normal production tolerances.
- Waveforms are taken with a oscilloscope. Voltage variations may be noted due to normal production tolerances.
- Circled numbers refer to waveforms.
- Signal path.
- $\text{---}\text{---}\text{---}$: SACD PLAY
- $\text{---}\text{---}\text{---}$: CD PLAY (ANALOG OUT)
- $\text{---}\text{---}\text{---}$: CD PLAY (DIGITAL OUT)

• Circuit Boards Location

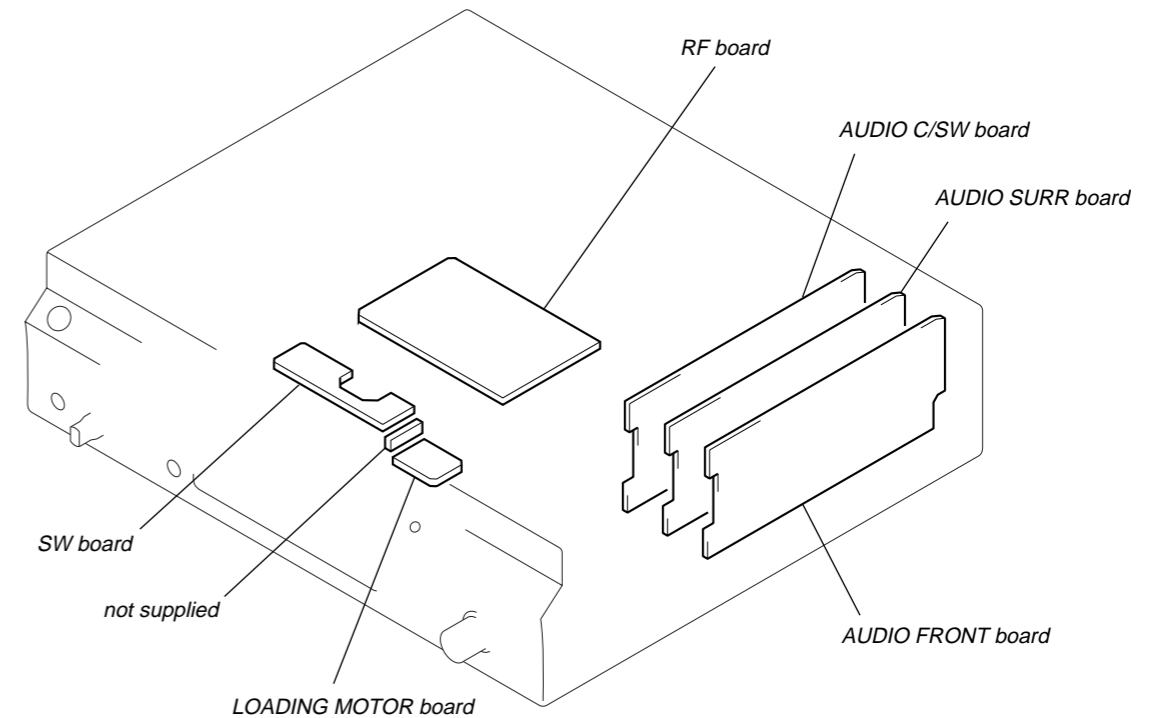
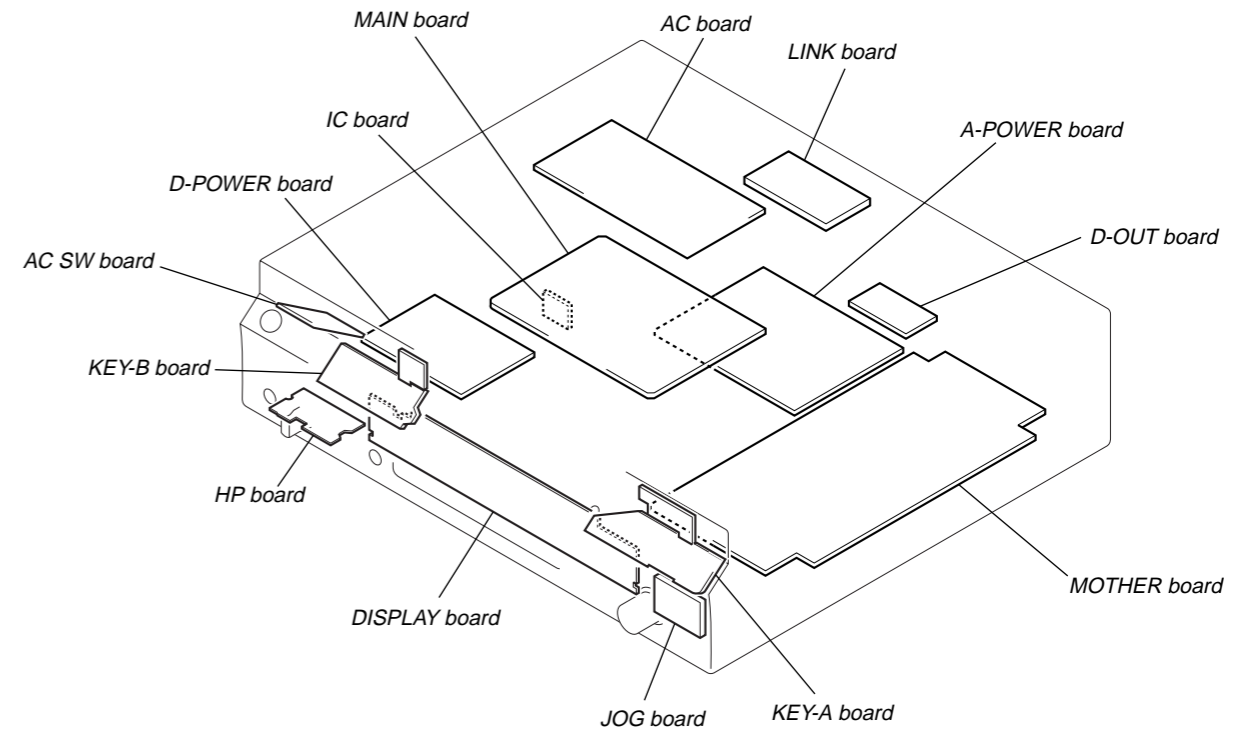

5-9. PRINTED WIRING BOARDS – SERVO Section – • See page 33 for Circuit Boards Location.  :Uses unleaded solder.

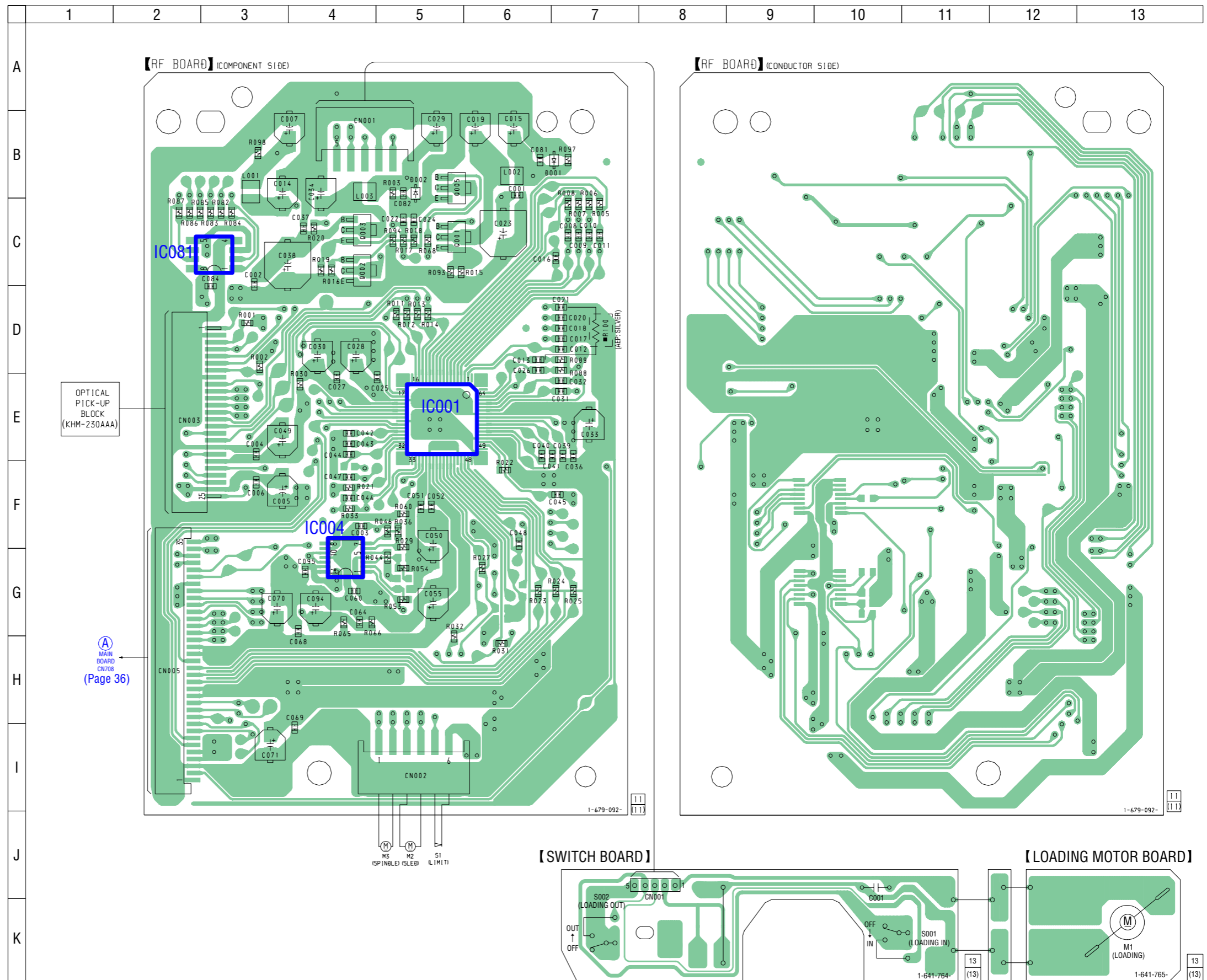

5-10. SCHEMATIC DIAGRAM – SERVO Section – • See page 65 for Waveforms. • See page 70 for IC Block Diagram.

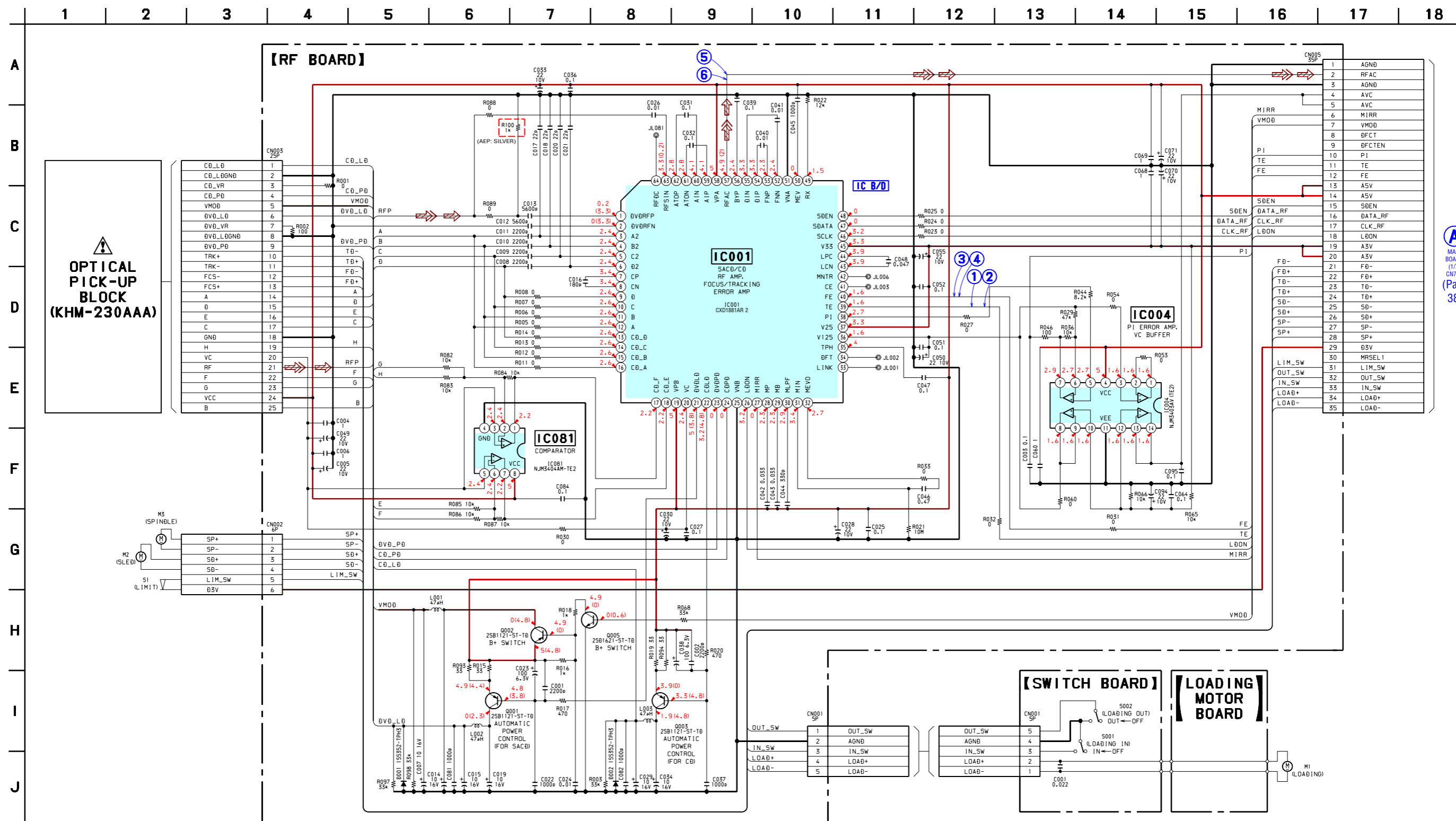

MAIN BOARD (1/7) CN708 (Page 38)

The components identified by mark Δ or dotted line with mark Δ are critical for safety. Replace only with part number specified.

Les composants identifiés par une marque Δ sont critiques pour la sécurité. Ne les remplacer que par une pièce portant le numéro spécifié.

5-11. PRINTED WIRING BOARD – MAIN Board (Component Side) – • See page 33 for Circuit Boards Location.  :Uses unleaded solder.

• Semiconductor Location

Ref. No.	Location
IC504	C-8
IC509	C-12
IC701	E-7
IC702	I-4
IC801	I-7
IC802	G-11
IC804	F-11
IC811	F-11
IC812	G-6
IC813	G-7
IC814	G-7
IC815	J-6
IC901	F-4

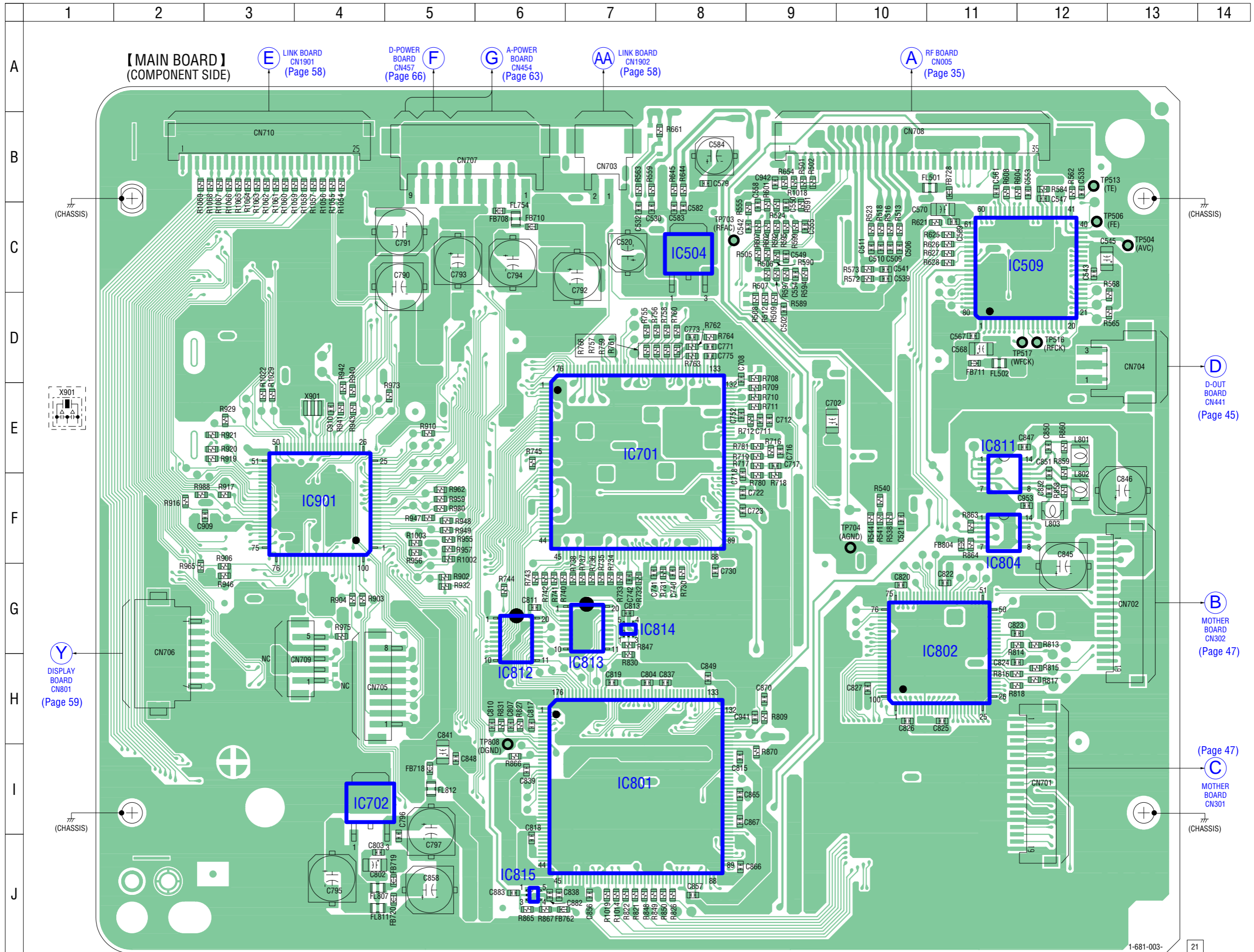

5-12. PRINTED WIRING BOARD – MAIN Board (Conductor Side) – • See page 33 for Circuit Boards Location.  :Uses unleaded solder.

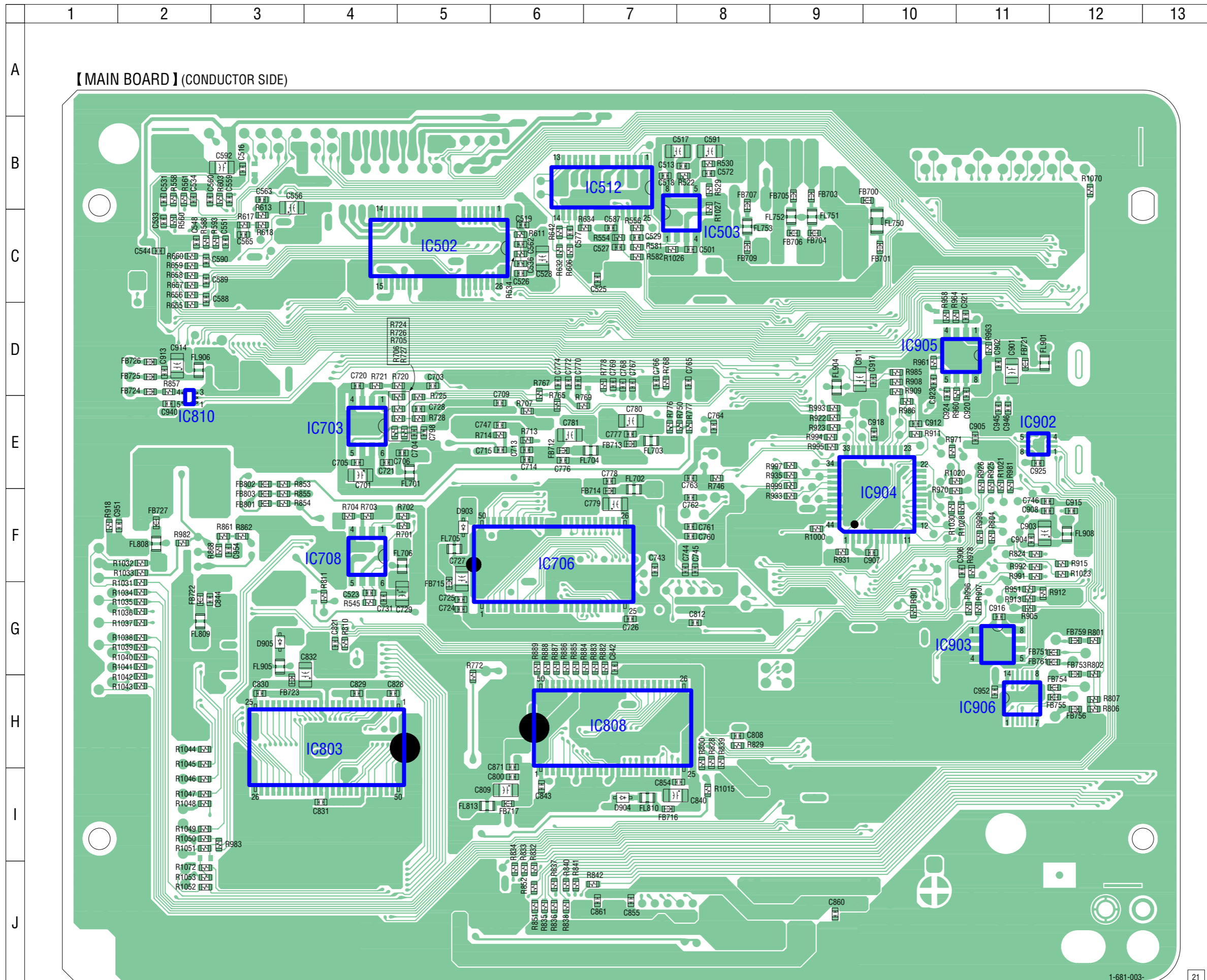

• Semiconductor Location

Ref. No.	Location
D903	F-5
D904	I-7
D905	G-3
IC502	C-5
IC503	C-8
IC512	B-7
IC703	E-4
IC706	F-6
IC708	F-4
IC803	H-4
IC808	H-7
IC810	E-2
IC902	E-11
IC903	G-11
IC904	F-10
IC905	D-11
IC906	H-11

5-13. SCHEMATIC DIAGRAM – MAIN Board (1/7) – • See page 65 for Waveforms. • See page 70 for IC Block Diagram.

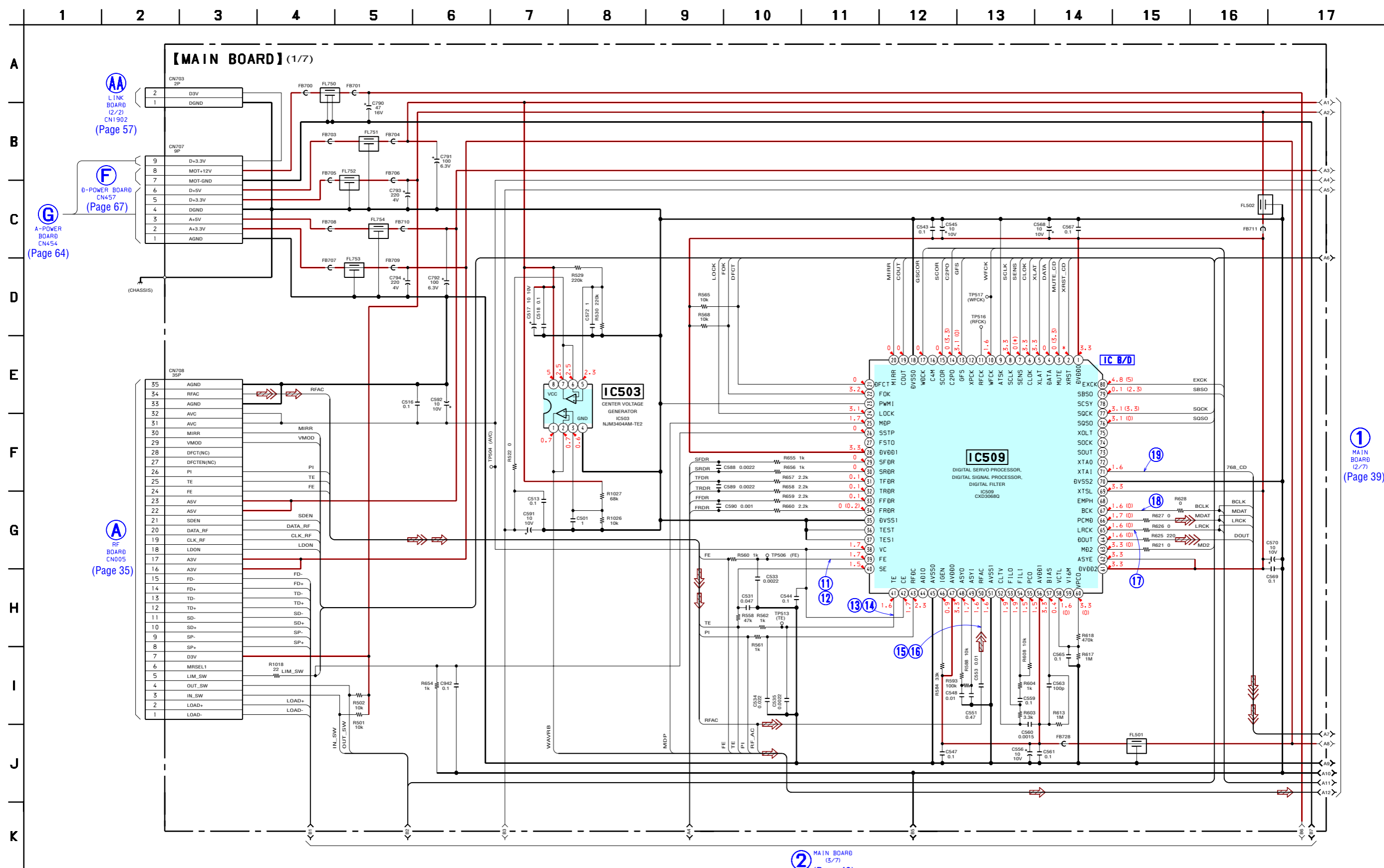

2 MAIN BOARD (3/7) (Page 40)

1 MAIN BOARD (2/7) (Page 39)

5-14. SCHEMATIC DIAGRAM – MAIN Board (2/7) – • See page 65 for Waveform. • See page 70 for IC Block Diagram.

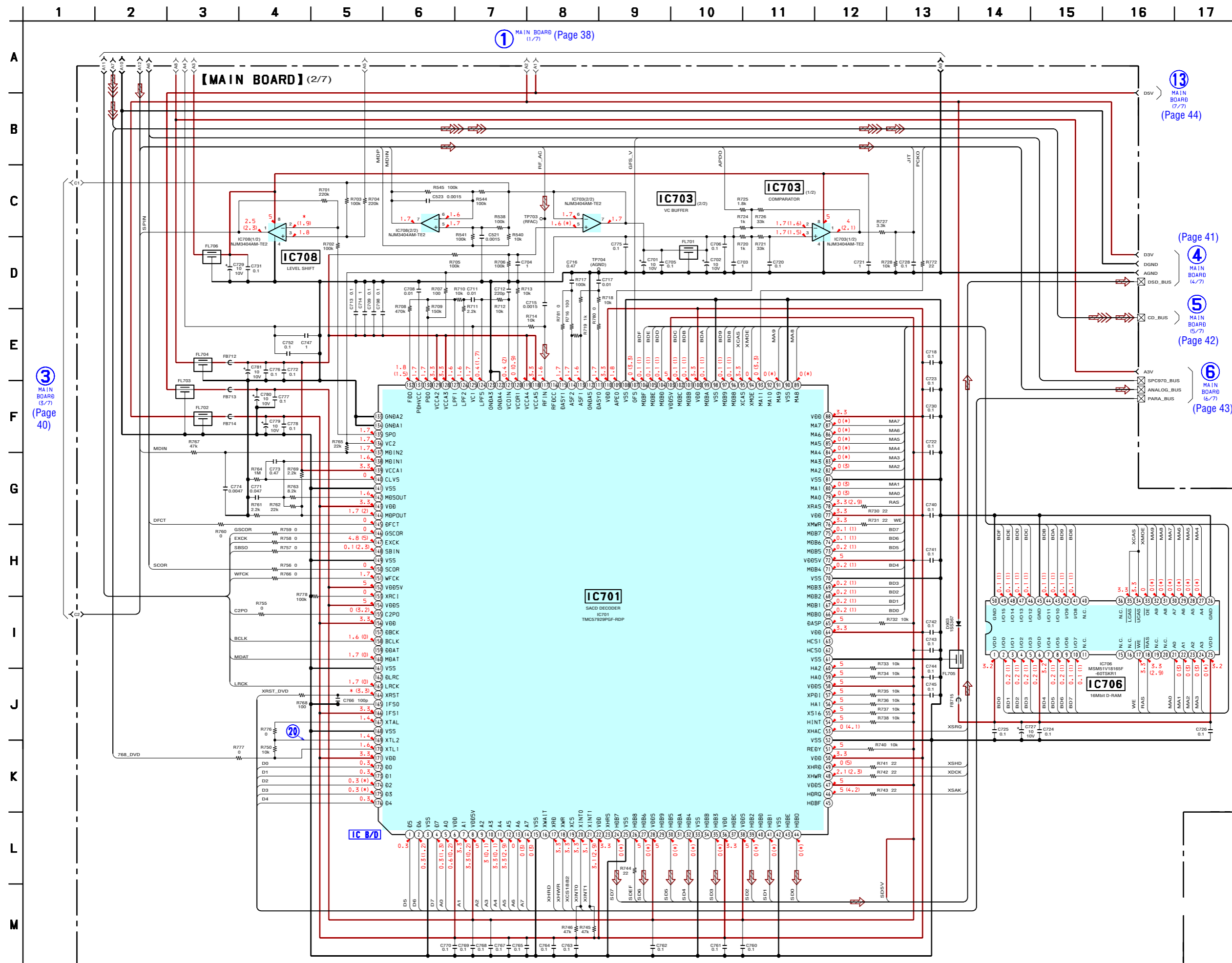

5-15. SCHEMATIC DIAGRAM – MAIN Board (3/7) –

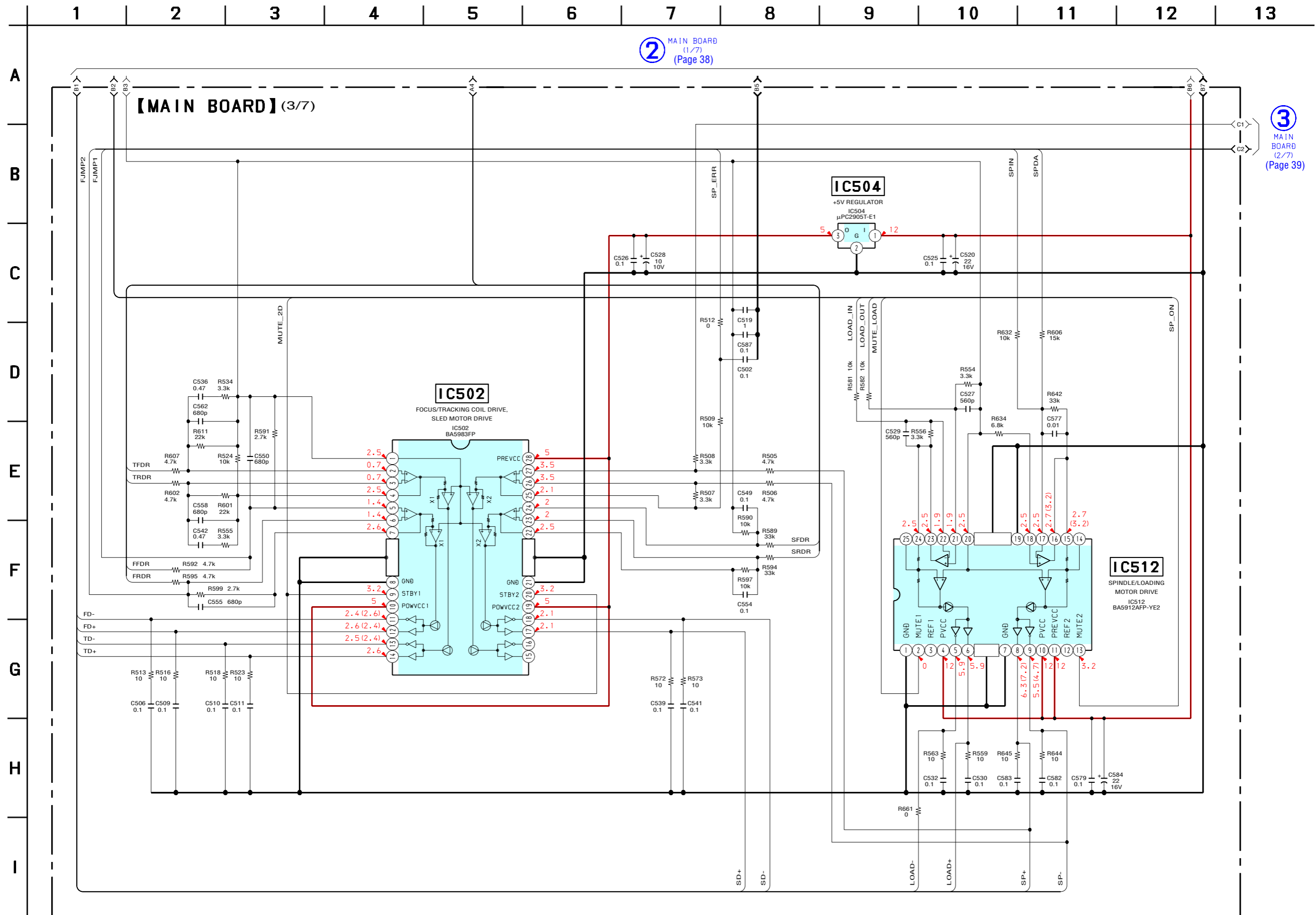

5-16. SCHEMATIC DIAGRAM – MAIN Board (4/7) – See page 65 for Waveforms.

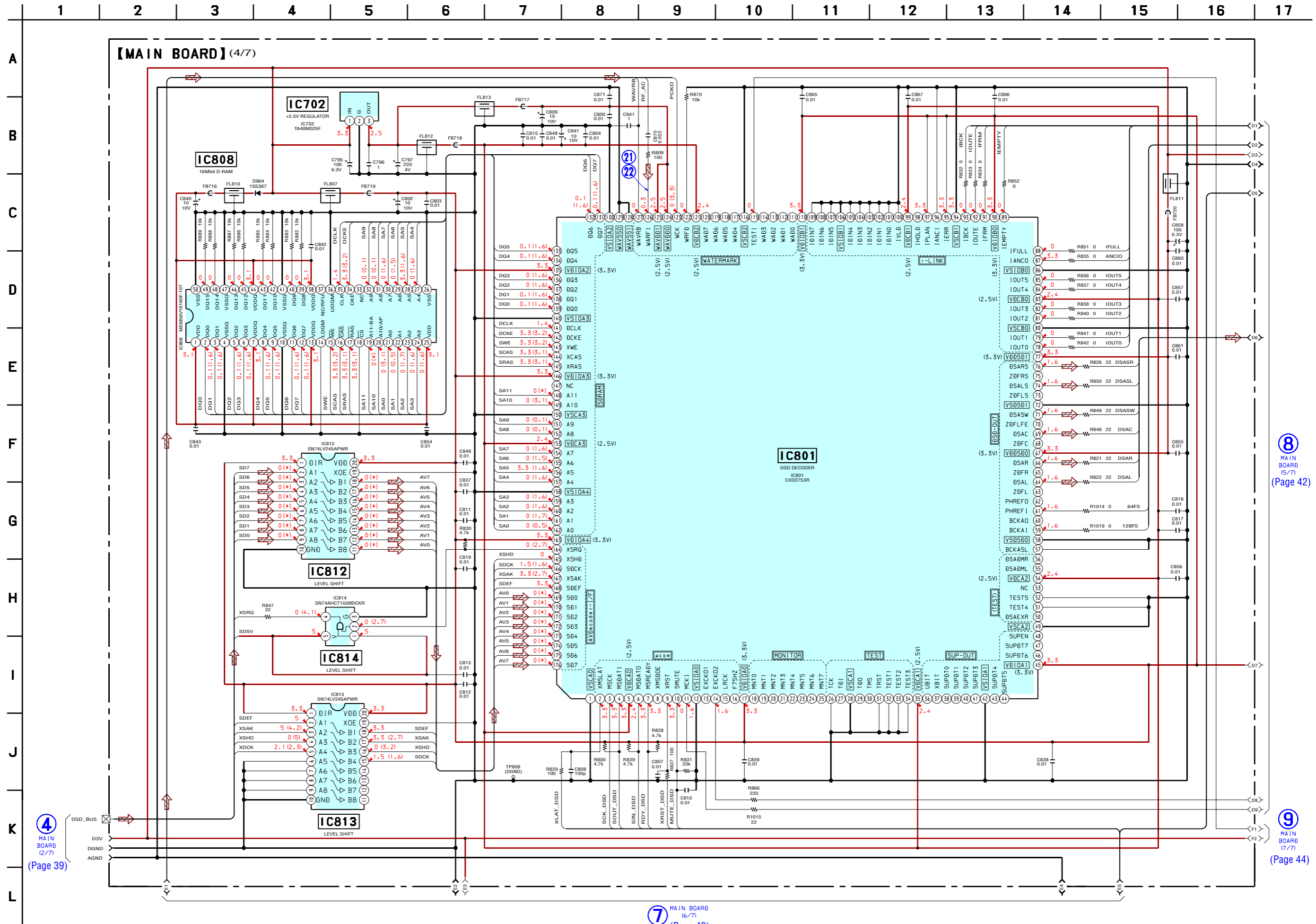

4 MAIN BOARD (2/7) (Page 39)

8 MAIN BOARD (5/7) (Page 42)

9 MAIN BOARD (7/7) (Page 44)

7 MAIN BOARD (6/7) (Page 43)

5-17. SCHEMATIC DIAGRAM – MAIN Board (5/7) – • See page 65 for Waveforms.

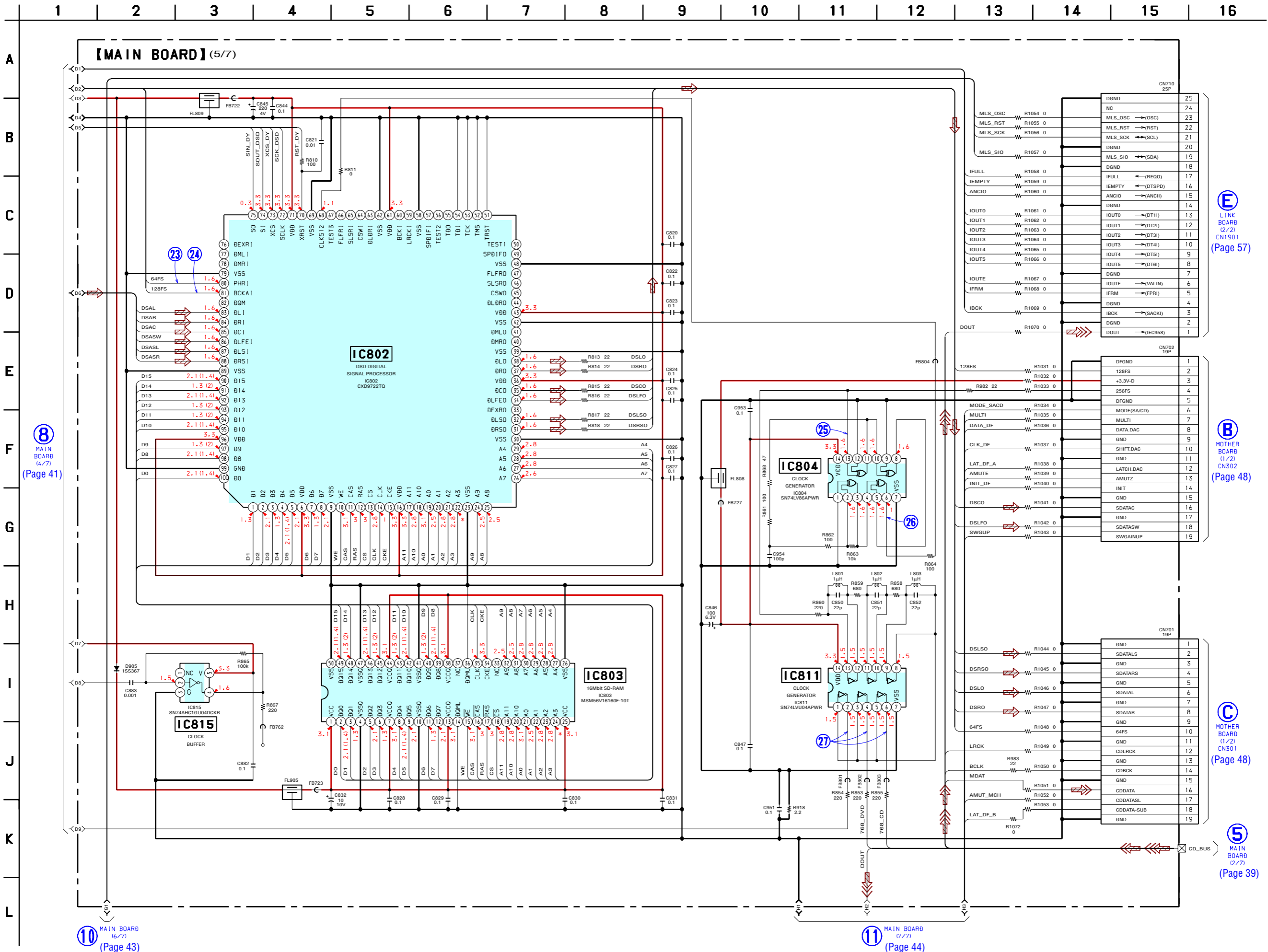

8 MAIN BOARD (4/7) (Page 41)

E LINK BOARD (2/2) CN1901 (Page 57)

B MOTHER BOARD (1/2) CN502 (Page 48)

C MOTHER BOARD (1/2) CN501 (Page 48)

5 MAIN BOARD (2/7) (Page 39)

10 MAIN BOARD (6/7) (Page 43)

11 MAIN BOARD (7/7) (Page 44)

5-18. SCHEMATIC DIAGRAM – MAIN Board (6/7) – • See page 65 for Waveforms. • See page 70 for IC Block Diagrams.

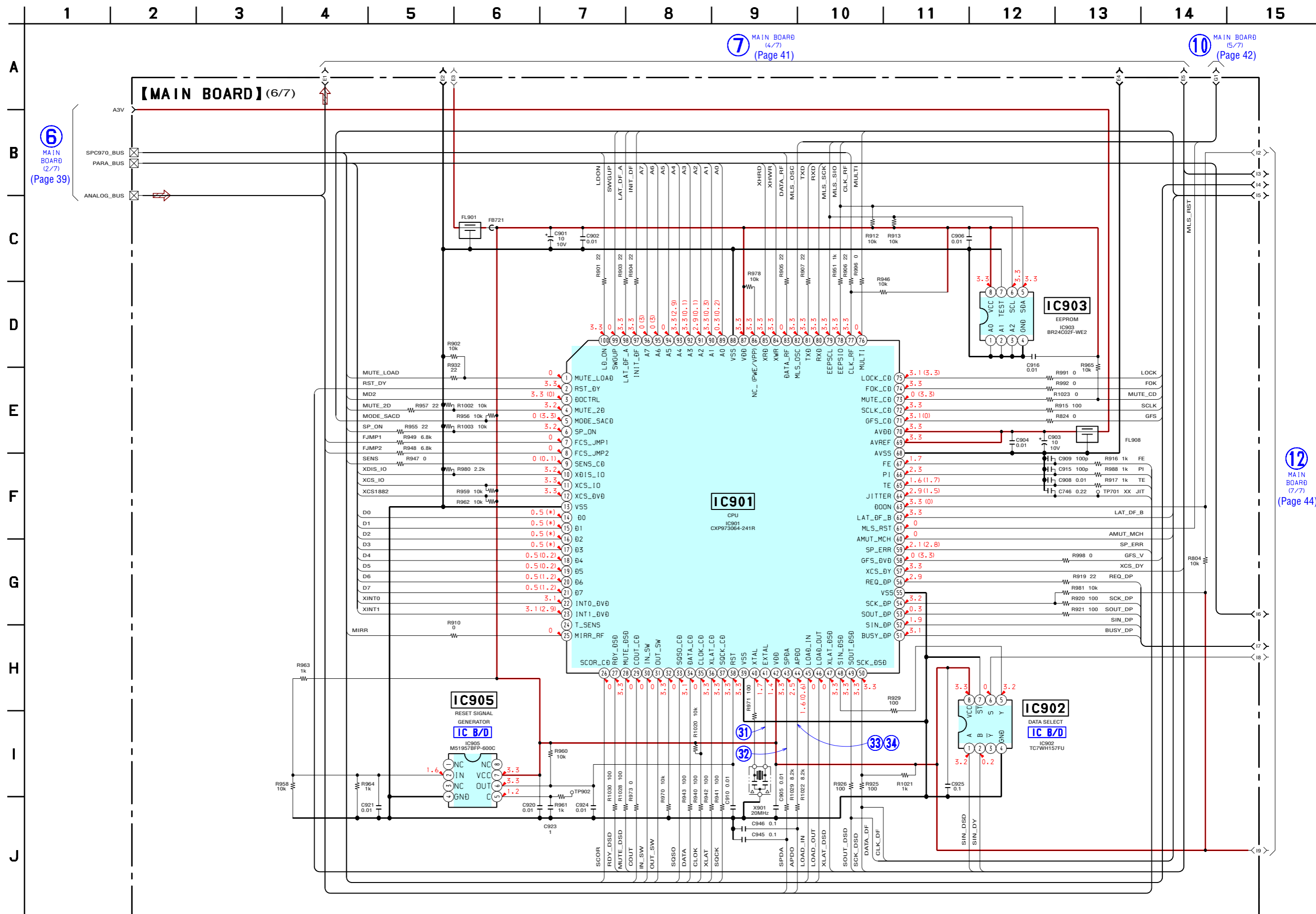

5-19. SCHEMATIC DIAGRAM – MAIN Board (7/7) –

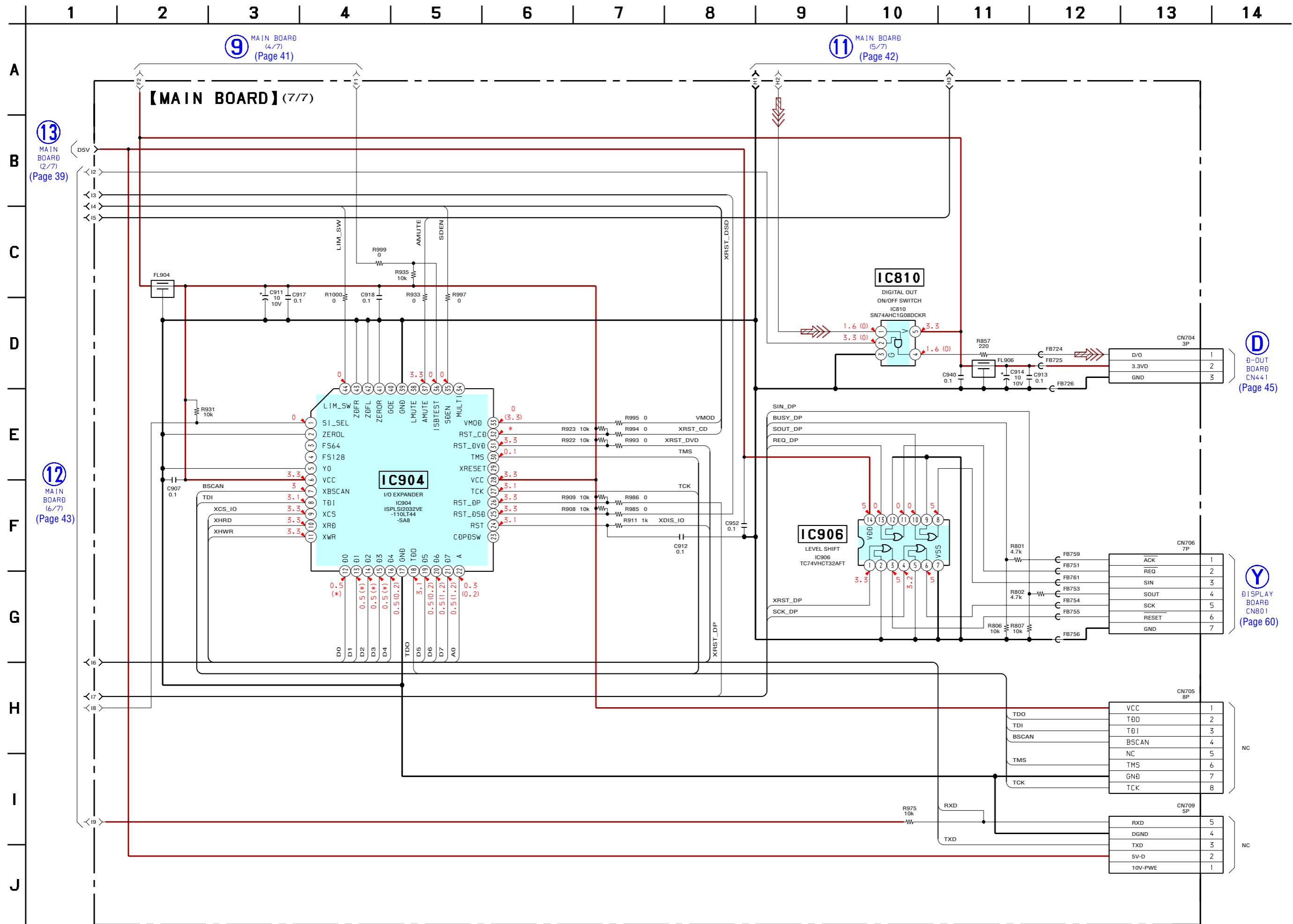

5-20. PRINTED WIRING BOARD – D-OUT Board – • See page 33 for Circuit Boards Location.

 :Uses unleaded solder.

【D-OUT BOARD】(COMPONENT SIDE)

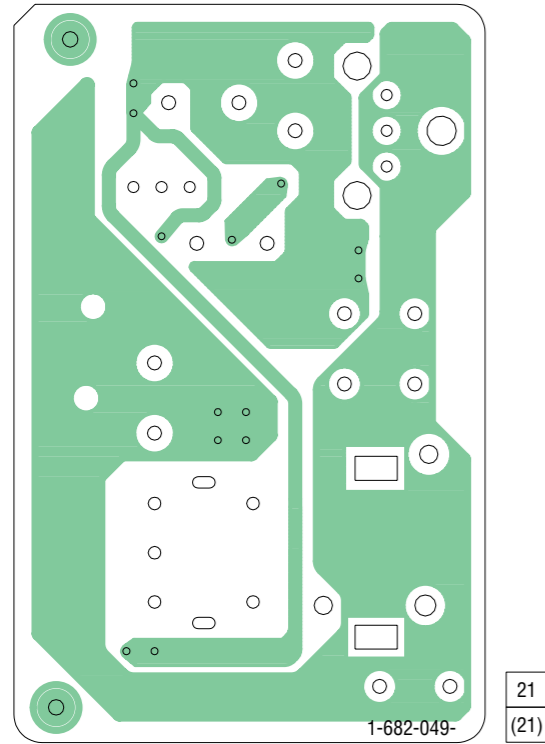

【D-OUT BOARD】(CONDUCTOR SIDE)

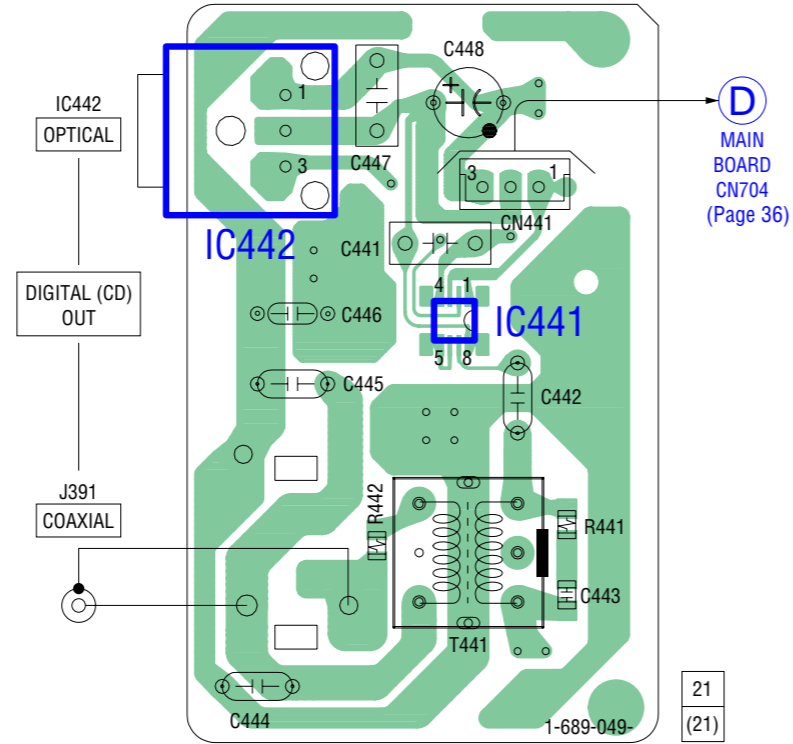

5-21. SCHEMATIC DIAGRAM – D-OUT Board –

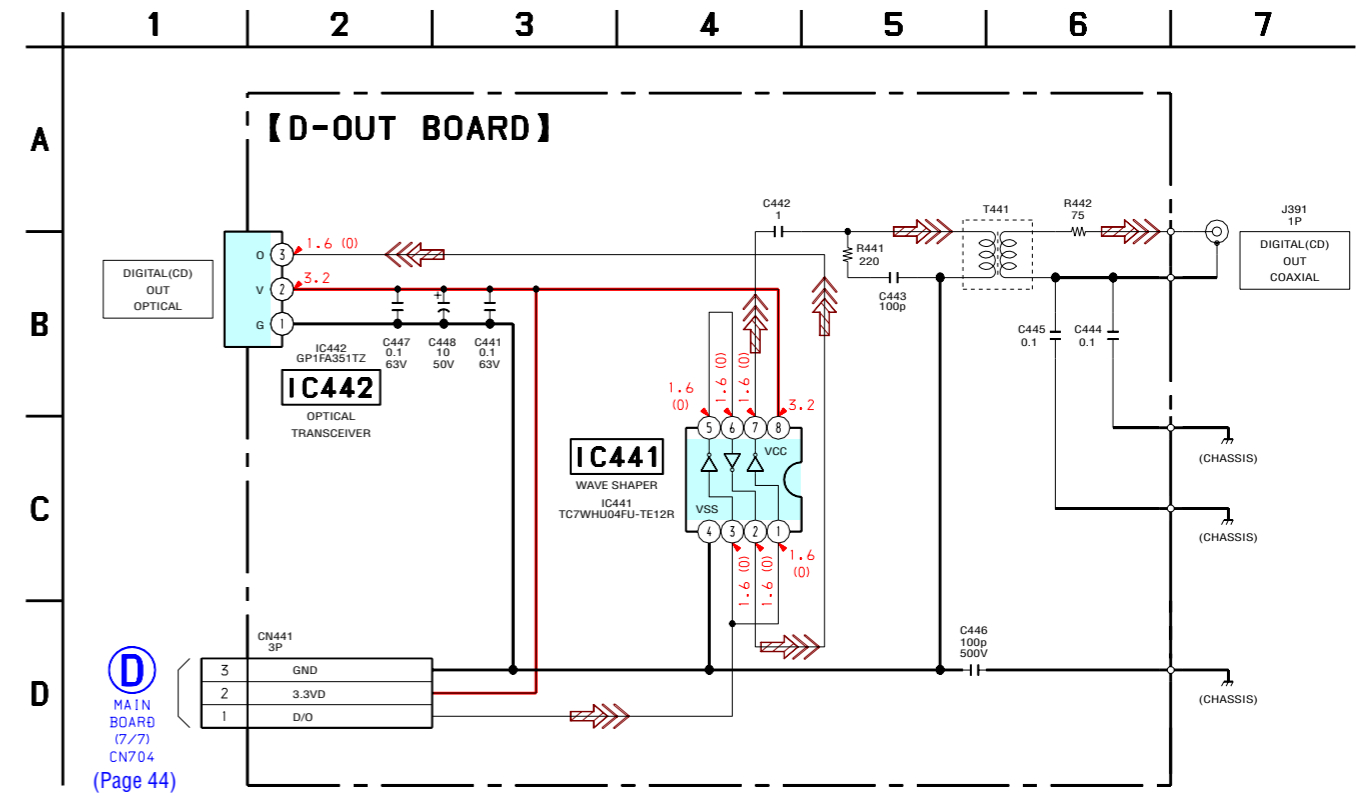

5-22. PRINTED WIRING BOARD – MOTHER Board (Component Side) – • See page 33 for Circuit Boards Location.  :Uses unleaded solder.

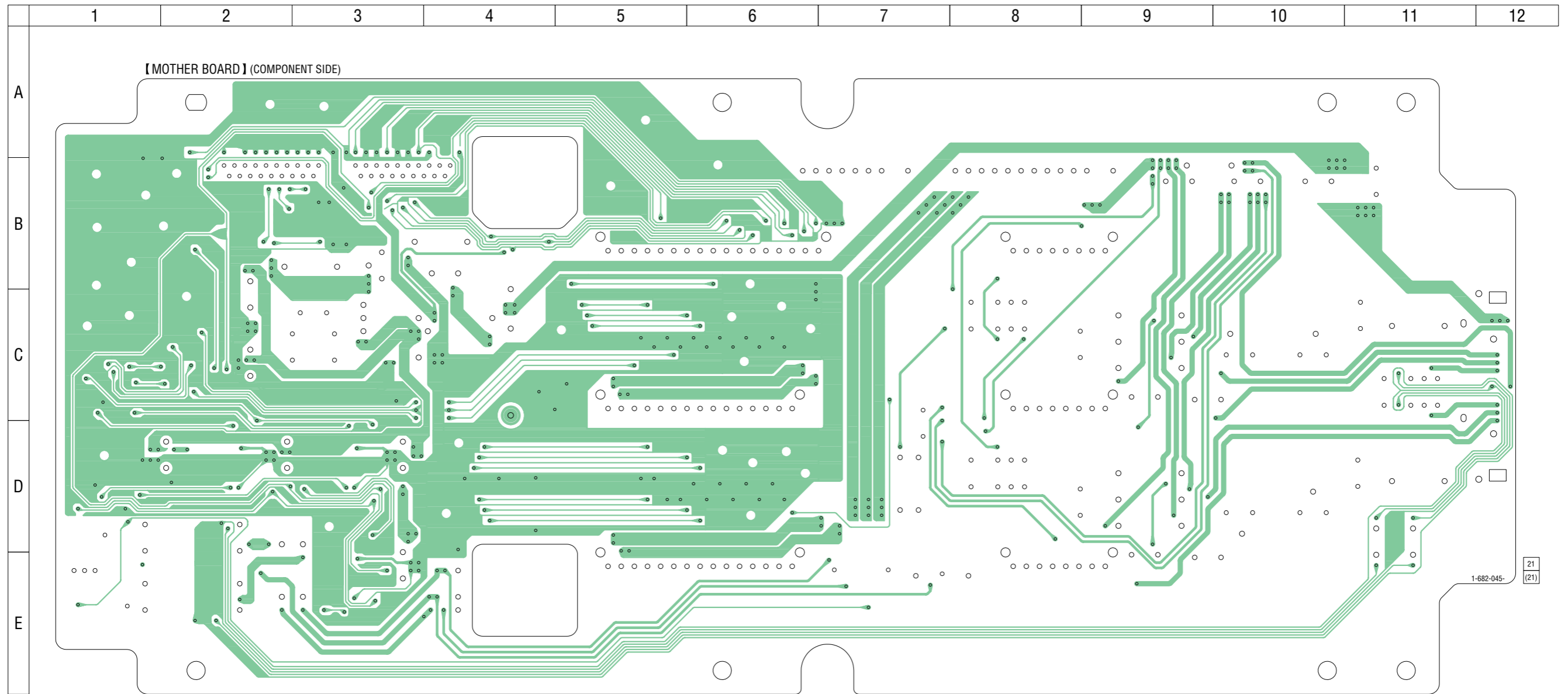

5-23. PRINTED WIRING BOARD – MOTHER Board (Conductor Side) – • See page 33 for Circuit Boards Location.  :Uses unleaded solder.

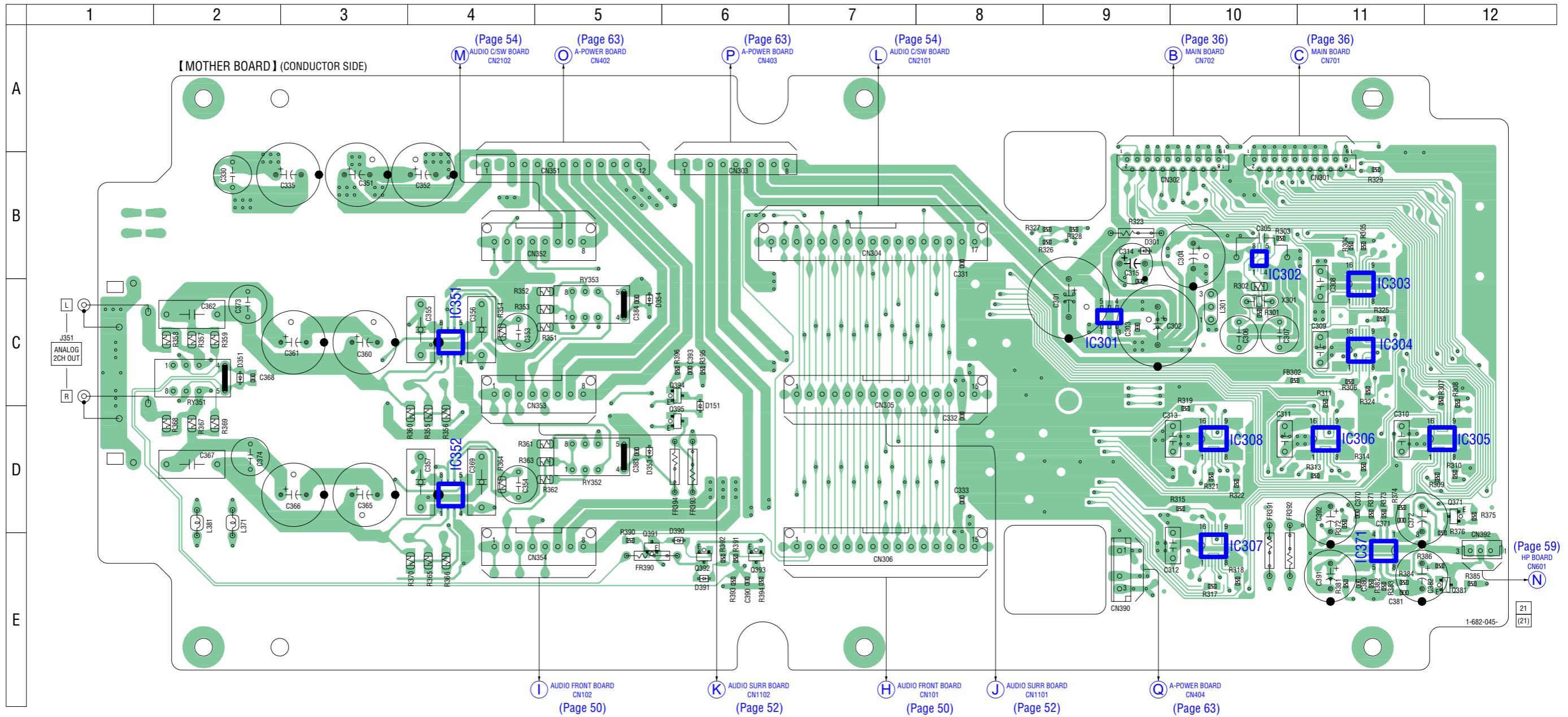

• Semiconductor Location

Ref. No.	Location	Ref. No.	Location
D151	D-6	IC307	E-10
D301	B-9	IC308	D-10
D351	C-2	IC351	C-4
D353	D-5	IC352	D-4
D354	C-5	IC371	E-11
D390	E-6		
D391	E-6	Q371	D-12
		Q381	E-12
IC301	C-9	Q391	E-5
IC302	B-10	Q392	E-6
IC303	C-11	Q393	E-6
IC304	C-11	Q394	C-6
IC305	D-12	Q395	D-6
IC306	D-11		

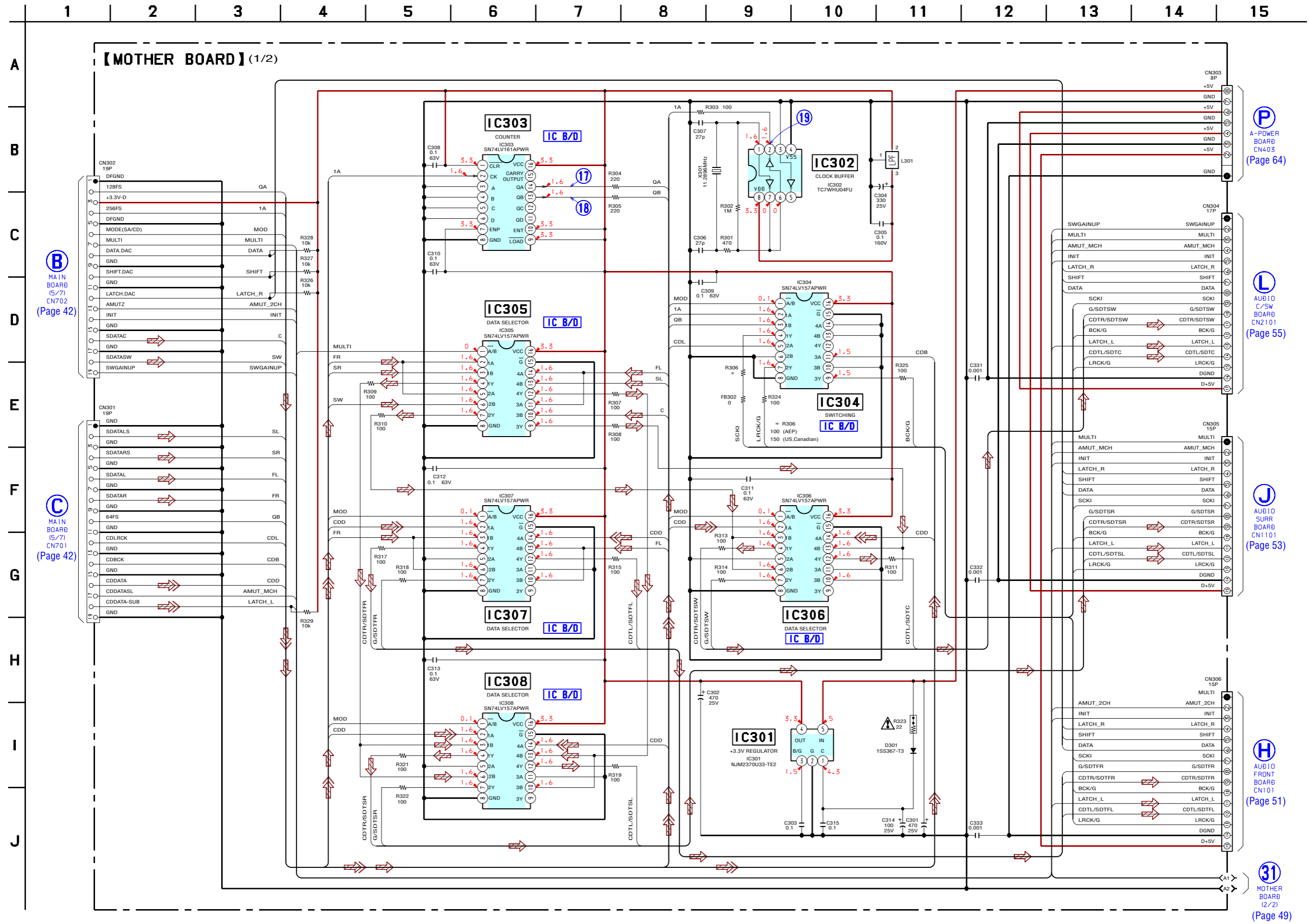

B MAIN BOARD (5/7) CN702 (Page 42)

C MAIN BOARD (5/7) CN701 (Page 42)

P A-POWER BOARD CN403 (Page 64)

L AUB10 C/SW BOARD CN2101 (Page 55)

J AUB10 SURR BOARD CN1101 (Page 53)

H AUB10 FRONT BOARD CN101 (Page 51)

31 MOTHER BOARD (2/2) (Page 49)

The components identified by mark Δ or dotted line with mark Δ are critical for safety. Replace only with part number specified.

Les composants identifiés par une marque Δ sont critiques pour la sécurité. Ne les remplacer que par une pièce portant le numéro spécifié.

5-25. SCHEMATIC DIAGRAM – MOTHER Board (2/2) –

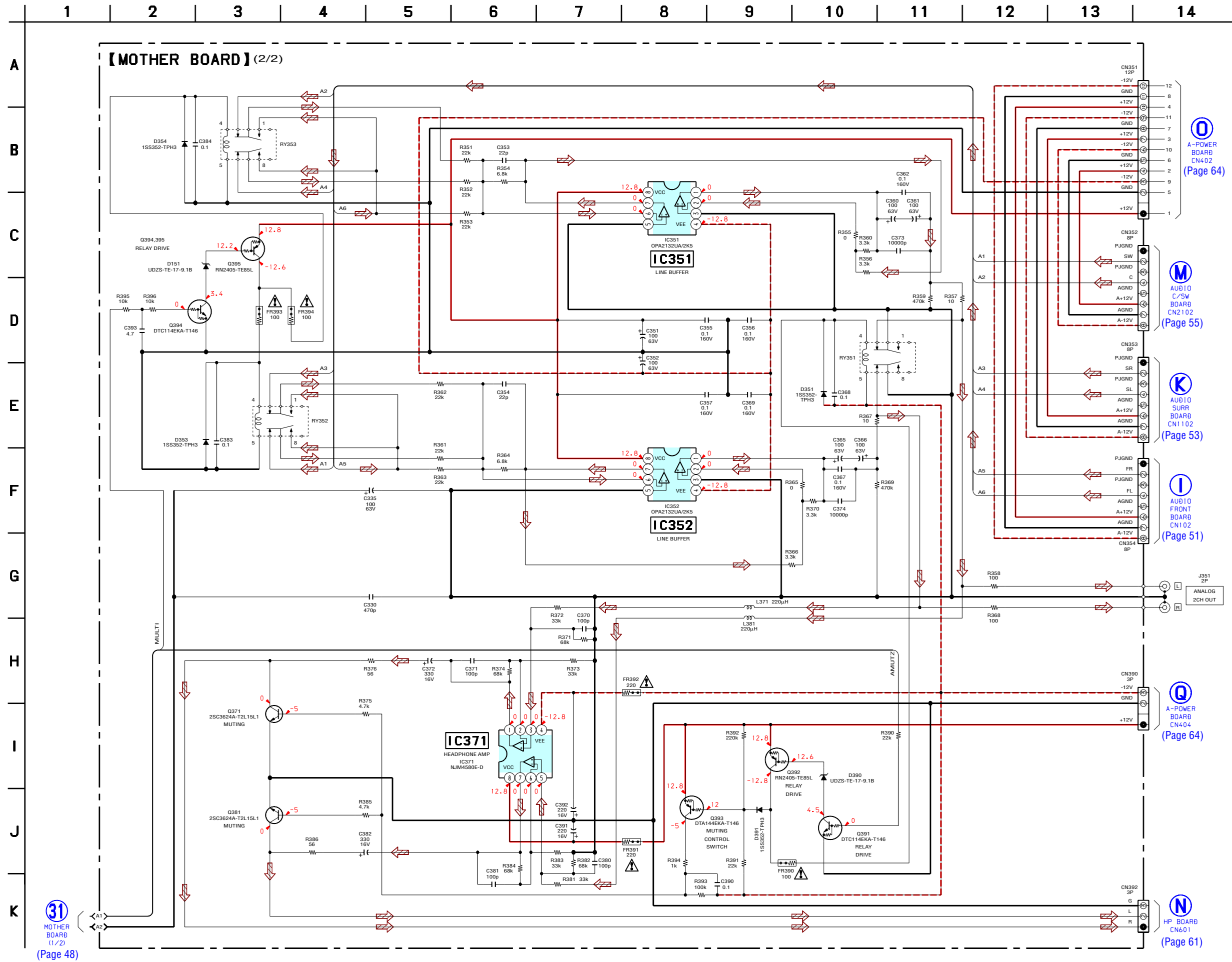

The components identified by mark \triangle or dotted line with mark \triangle are critical for safety. Replace only with part number specified.

Les composants identifiés par une marque \triangle sont critiques pour la sécurité. Ne les remplacer que par une pièce portant le numéro spécifié.

5-26. PRINTED WIRING BOARD – AUDIO FRONT Board – • See page 33 for Circuit Boards Location.  :Uses unleaded solder.

• Semiconductor Location

Ref. No.	Location
D152	D-2
D154	F-2
D155	F-8
IC101	F-6
IC102	F-5
IC103	F-3
IC151	F-8
IC201	E-6
IC202	E-5
IC203	E-3
Q153	D-2
Q154	D-2

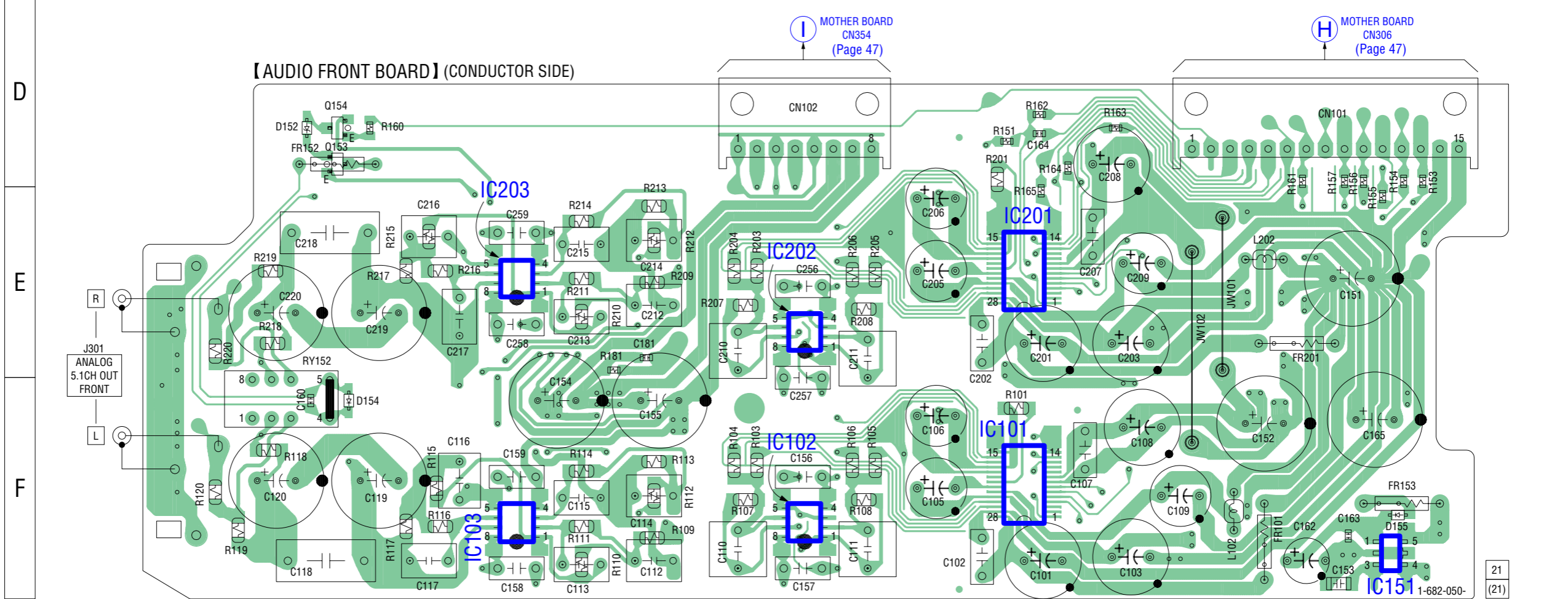
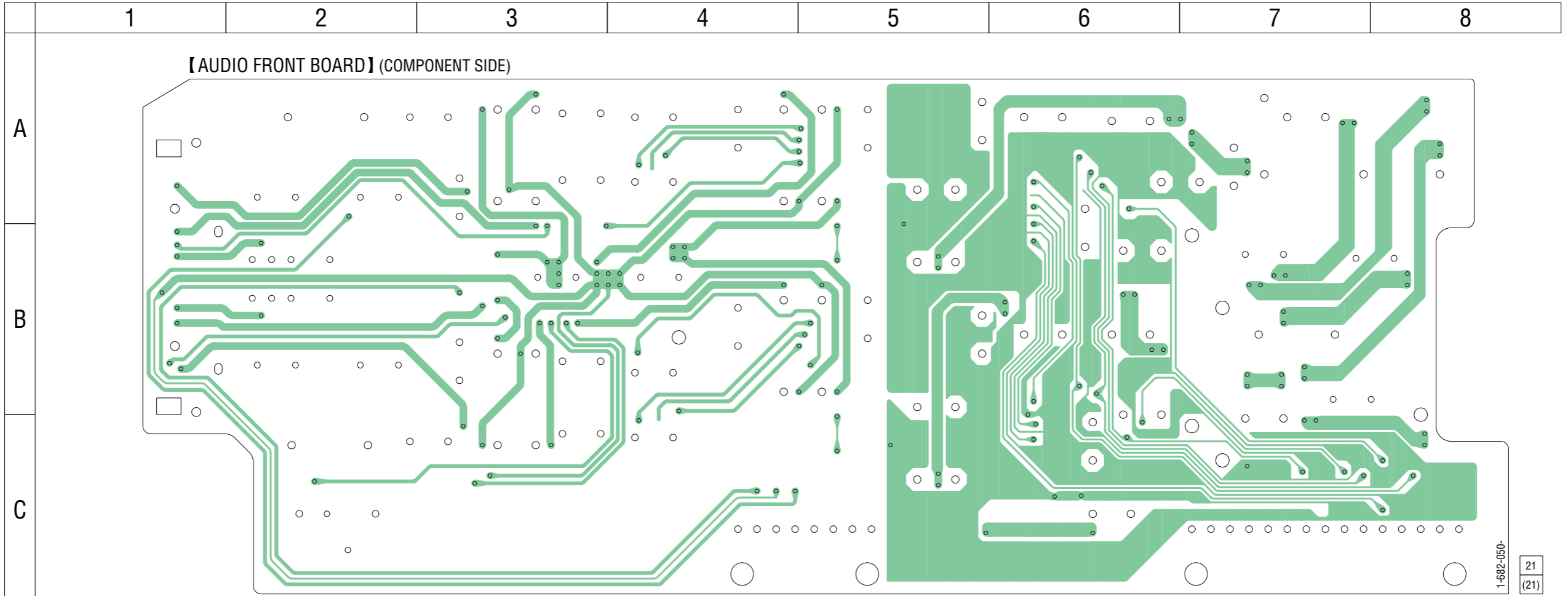

5-27. SCHEMATIC DIAGRAM – AUDIO FRONT Board – • See page 70 for IC Block Diagrams.

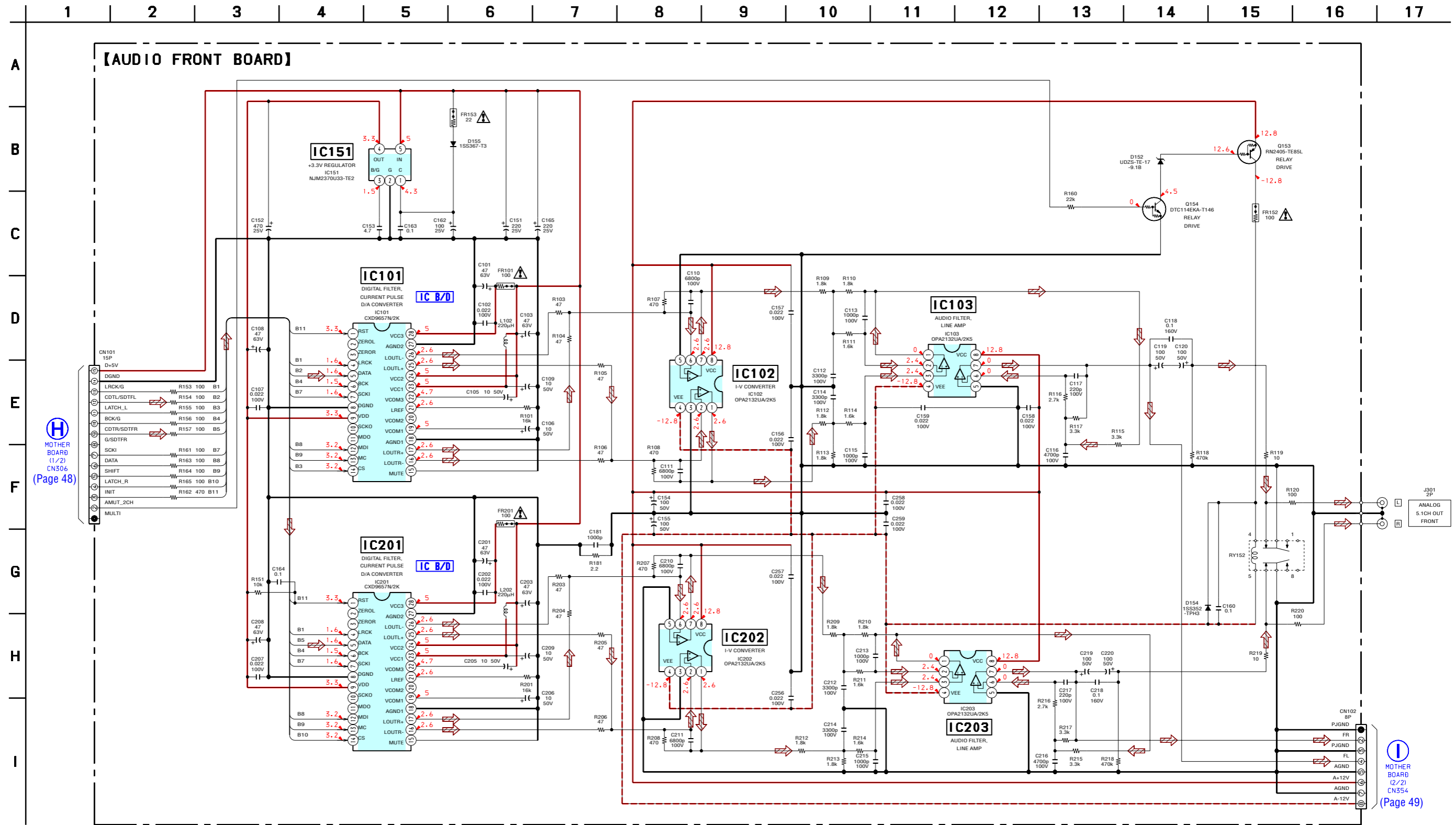

MOTHER BOARD (1/2) CN306 (Page 48)

MOTHER BOARD (2/2) CN354 (Page 49)

The components identified by mark △ or dotted line with mark △ are critical for safety. Replace only with part number specified. Les composants identifiés par une marque △ sont critiques pour la sécurité. Ne les remplacer que par une pièce portant le numéro spécifié.

• Semiconductor Location

Ref. No.	Location
D1151	D-3
D1152	D-2
D1153	F-3
D1154	F-2
D1155	F-8
IC1101	F-6
IC1102	F-5
IC1103	F-3
IC1151	F-8
IC1201	E-6
IC1202	E-5
IC1203	E-3
Q1151	D-3
Q1152	D-3
Q1153	D-2
Q1154	D-2

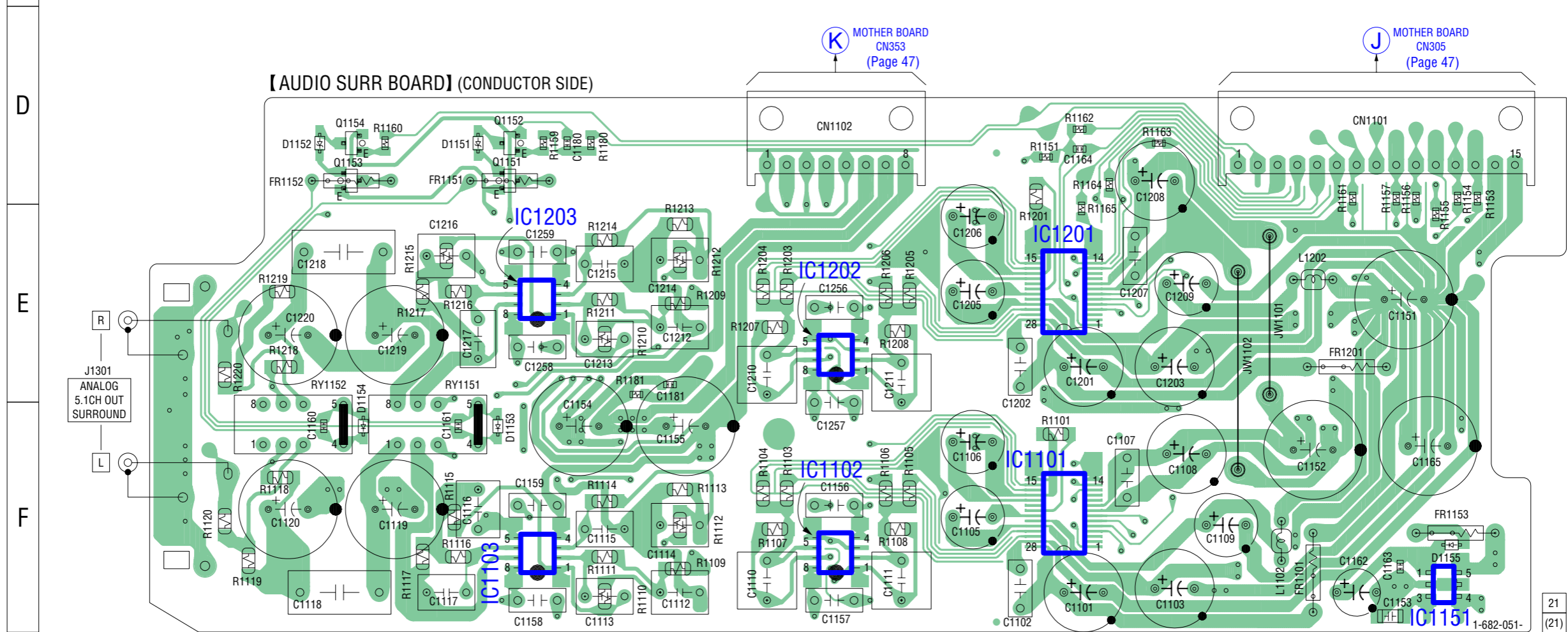
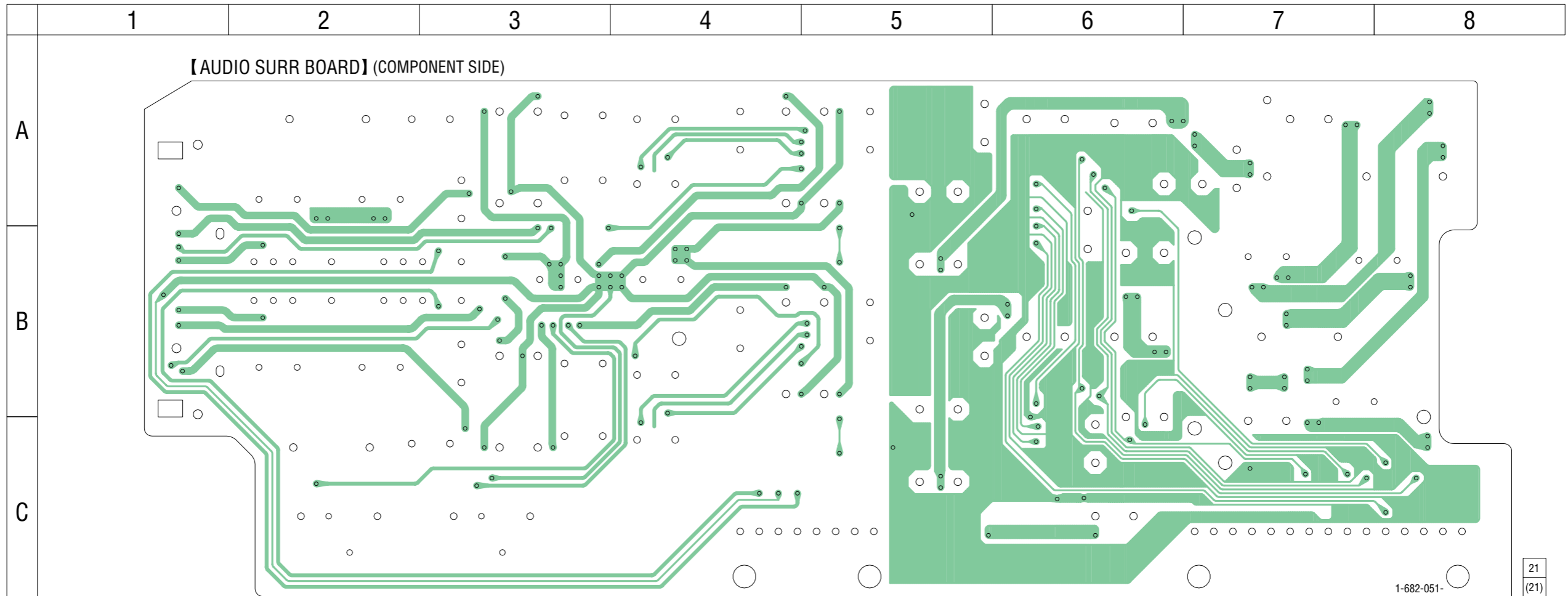

5-29. SCHEMATIC DIAGRAM – AUDIO SURR Board – • See page 70 for IC Block Diagrams.

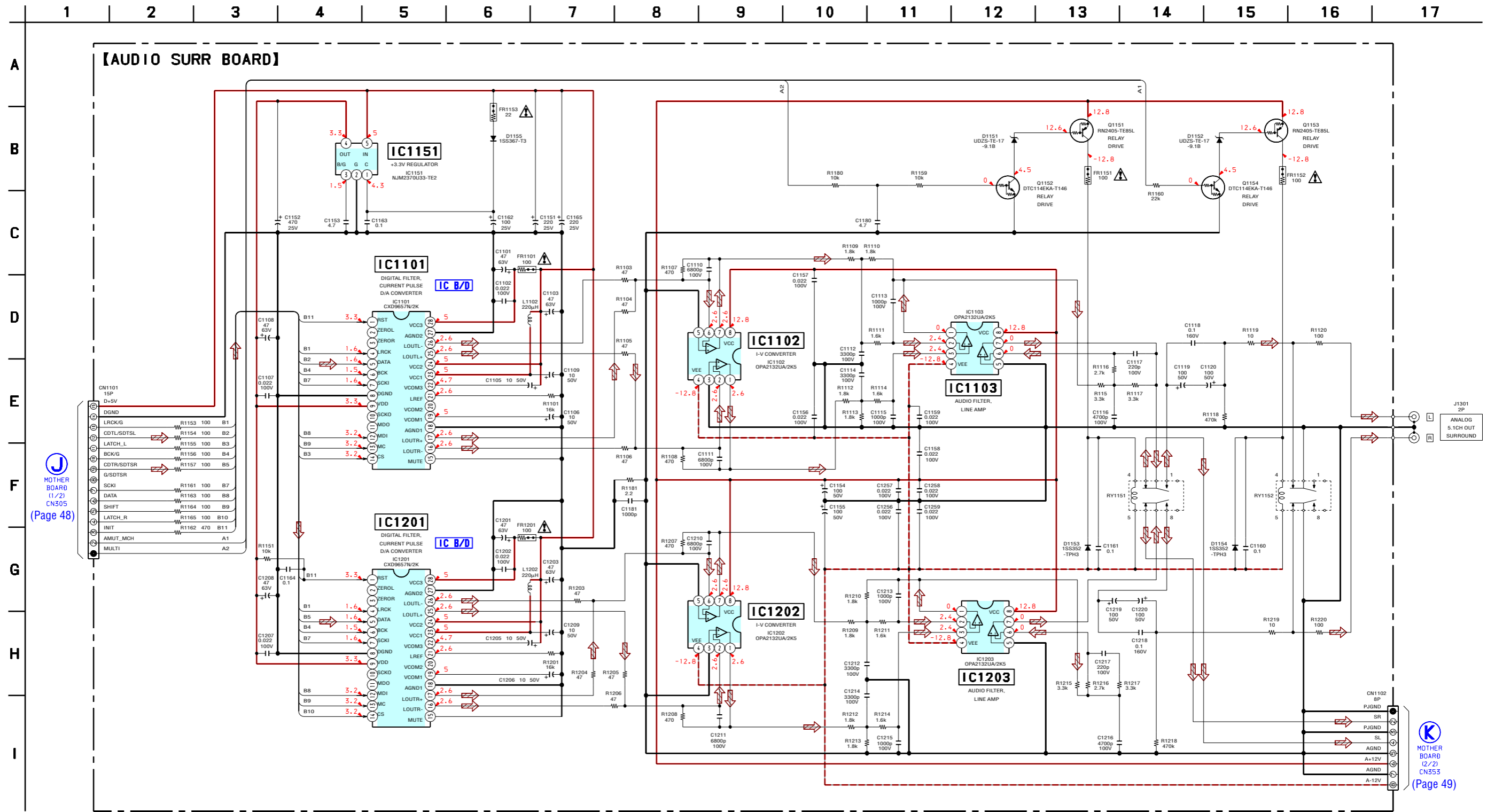

The components identified by mark \triangle or dotted line with mark \triangle are critical for safety. Replace only with part number specified.

Les composants identifiés par une marque \triangle sont critiques pour la sécurité. Ne les remplacer que par une pièce portant le numéro spécifié.

• Semiconductor Location

Ref. No.	Location
D2151	D-4
D2152	D-3
D2153	F-3
D2154	F-2
D2155	F-8
D2156	D-2
D2157	D-3
IC2101	F-6
IC2102	F-5
IC2103	F-3
IC2151	F-8
IC2201	E-6
IC2202	E-5
IC2203	E-3
Q2151	D-4
Q2152	D-4
Q2153	D-3
Q2154	D-3
Q2155	D-3
Q2156	D-3

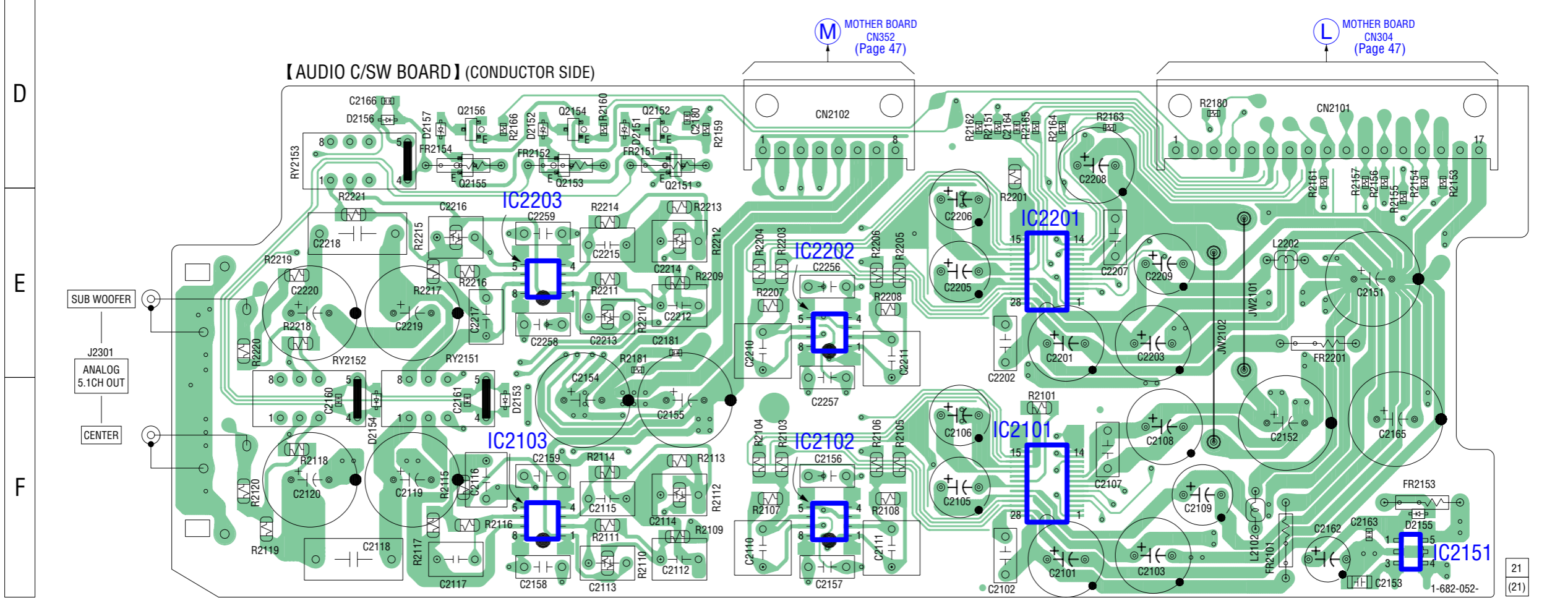
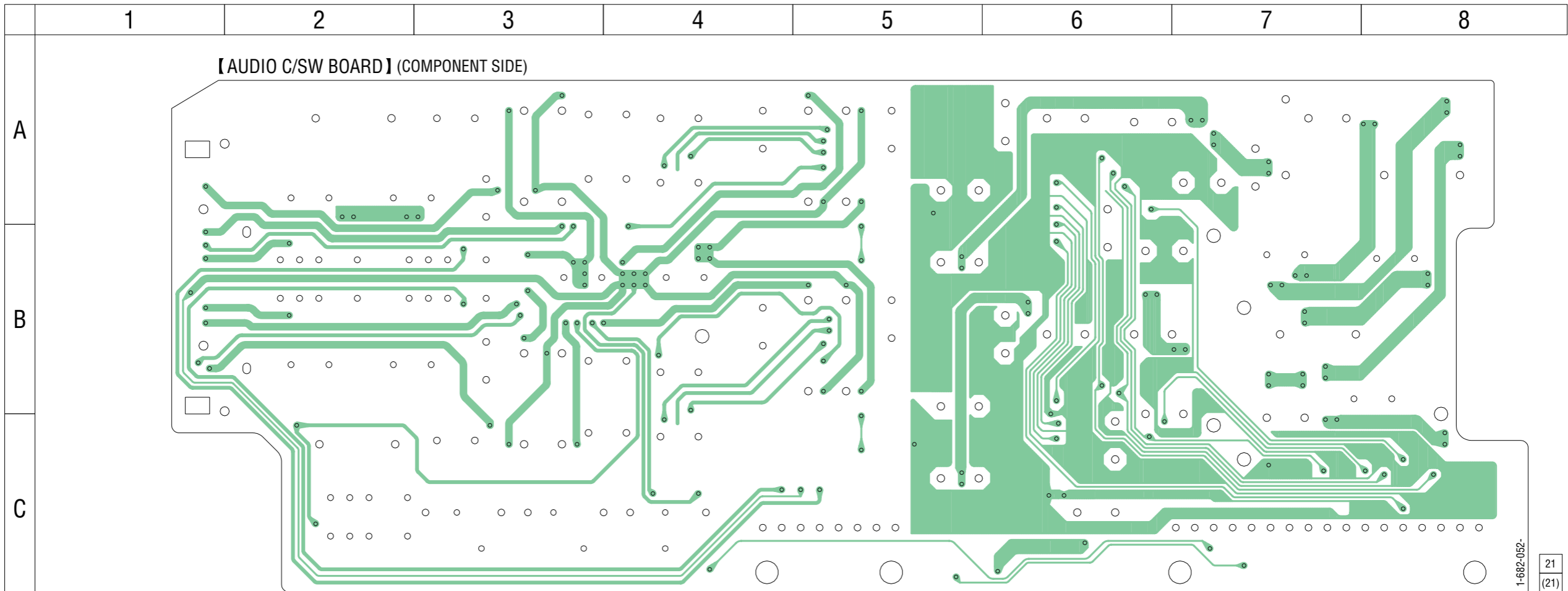

5-31. SCHEMATIC DIAGRAM – AUDIO C/SW Board – • See page 70 for IC Block Diagrams.

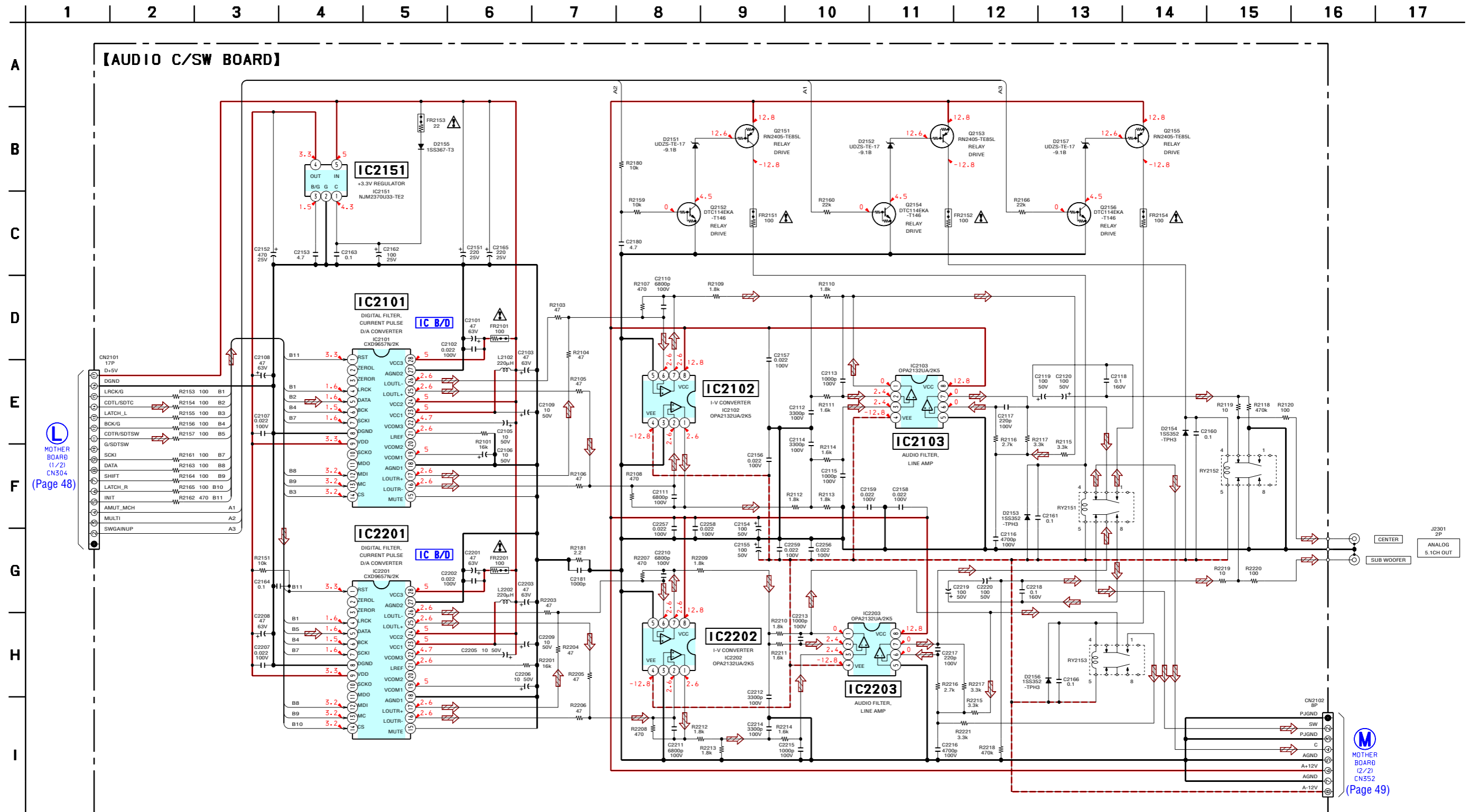

MOTHER BOARD (1/2) CN304 (Page 48)

MOTHER BOARD (2/2) CN352 (Page 49)

The components identified by mark \triangle or dotted line with mark \triangle are critical for safety. Replace only with part number specified.

Les composants identifiés par une marque \triangle sont critiques pour la sécurité. Ne les remplacer que par une pièce portant le numéro spécifié.

5-32. SCHEMATIC DIAGRAM – LINK Board (1/2) – • See page 70 for Waveforms.

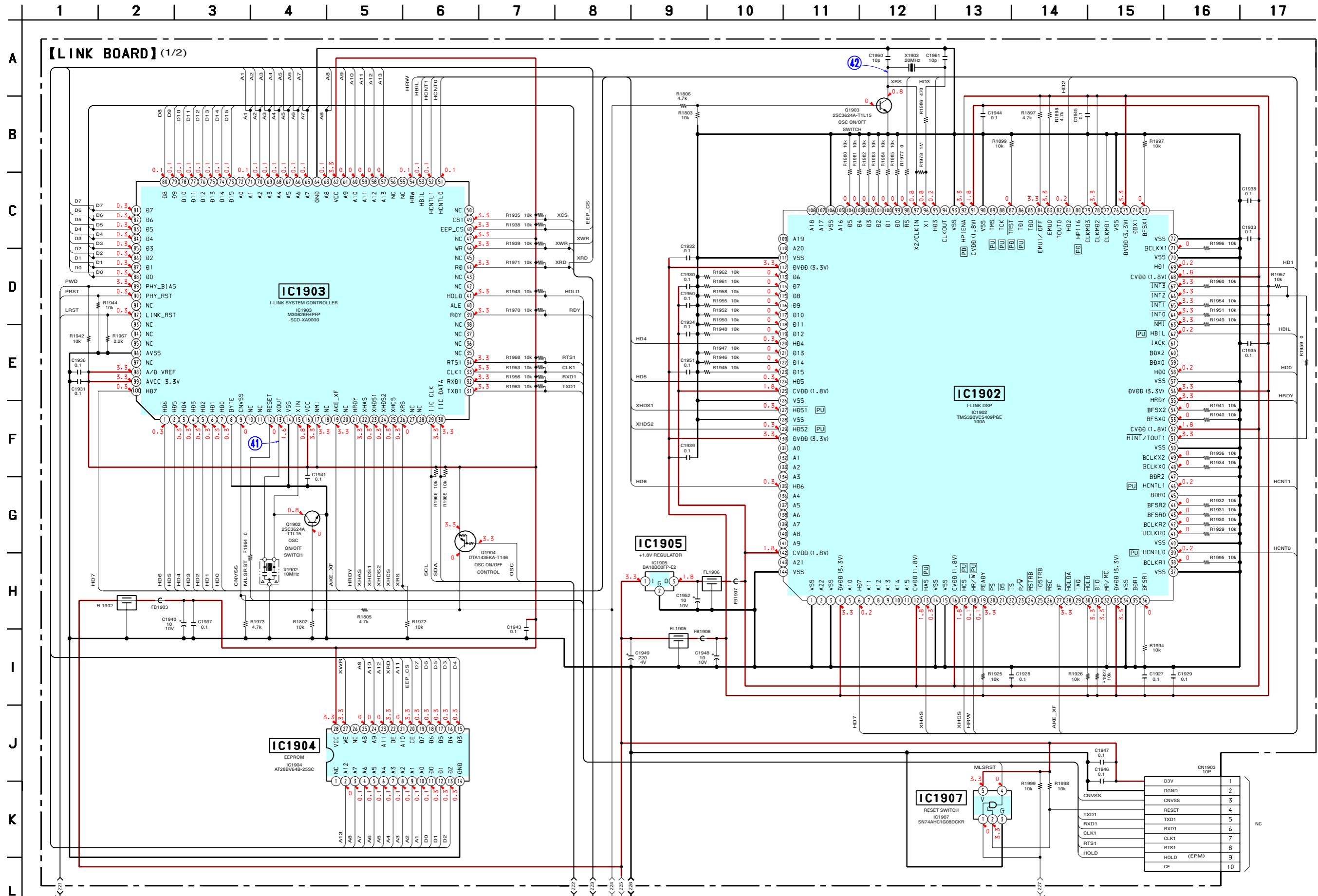

21 LINK BOARD (2/2)
(Page 57)

5-33. SCHEMATIC DIAGRAM – LINK Board (2/2) –

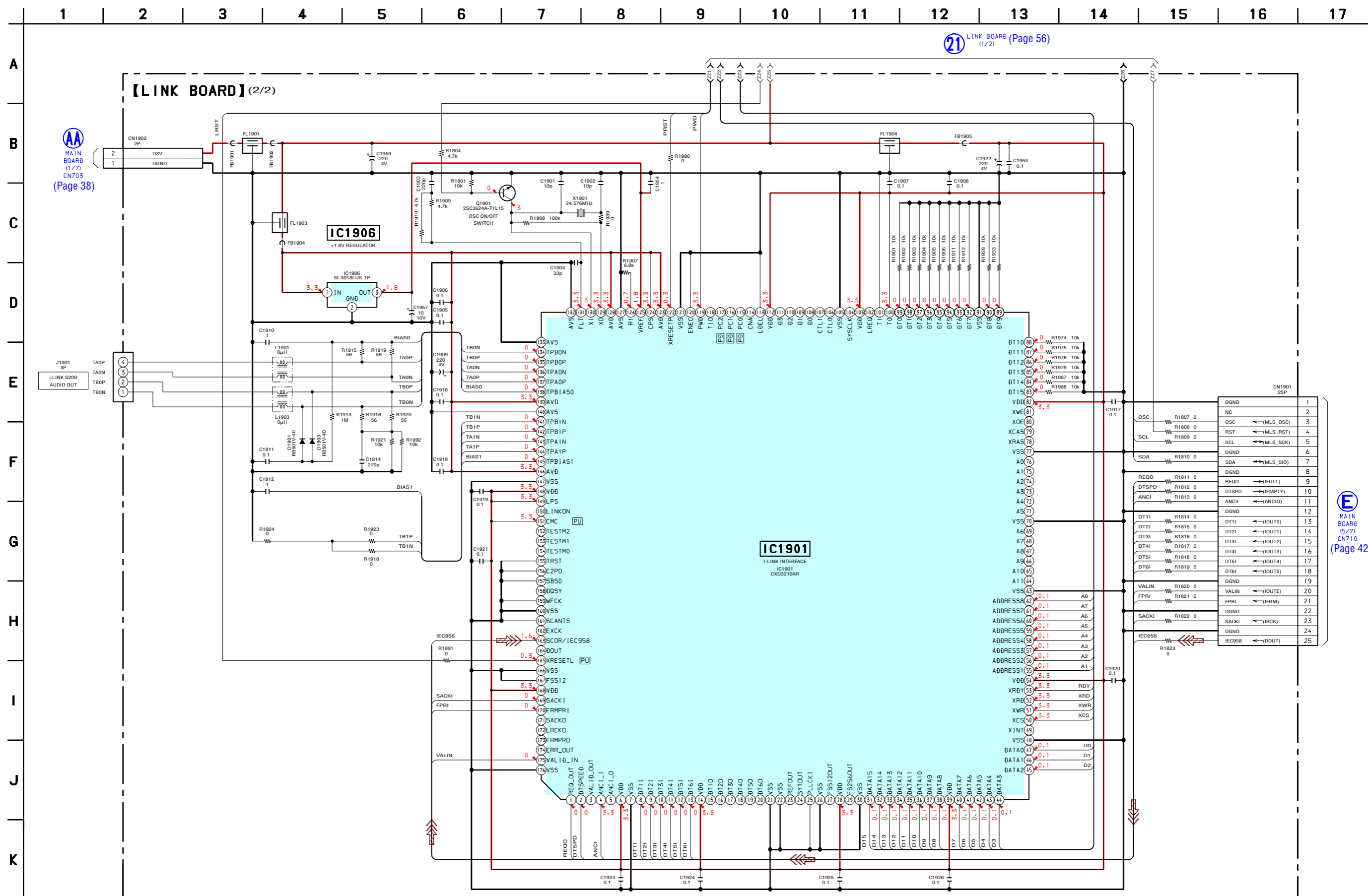

5-34. PRINTED WIRING BOARD – LINK Board – • See page 33 for Circuit Boards Location.  :Uses unleaded solder.

• Semiconductor Location

Ref. No.	Location
D1901	I-7
D1903	I-7
IC1901	D-6
IC1902	I-3
IC1903	C-3
IC1904	H-6
IC1905	H-3
IC1906	B-8
IC1907	G-2
Q1901	I-6
Q1902	C-2
Q1903	J-2
Q1904	I-2

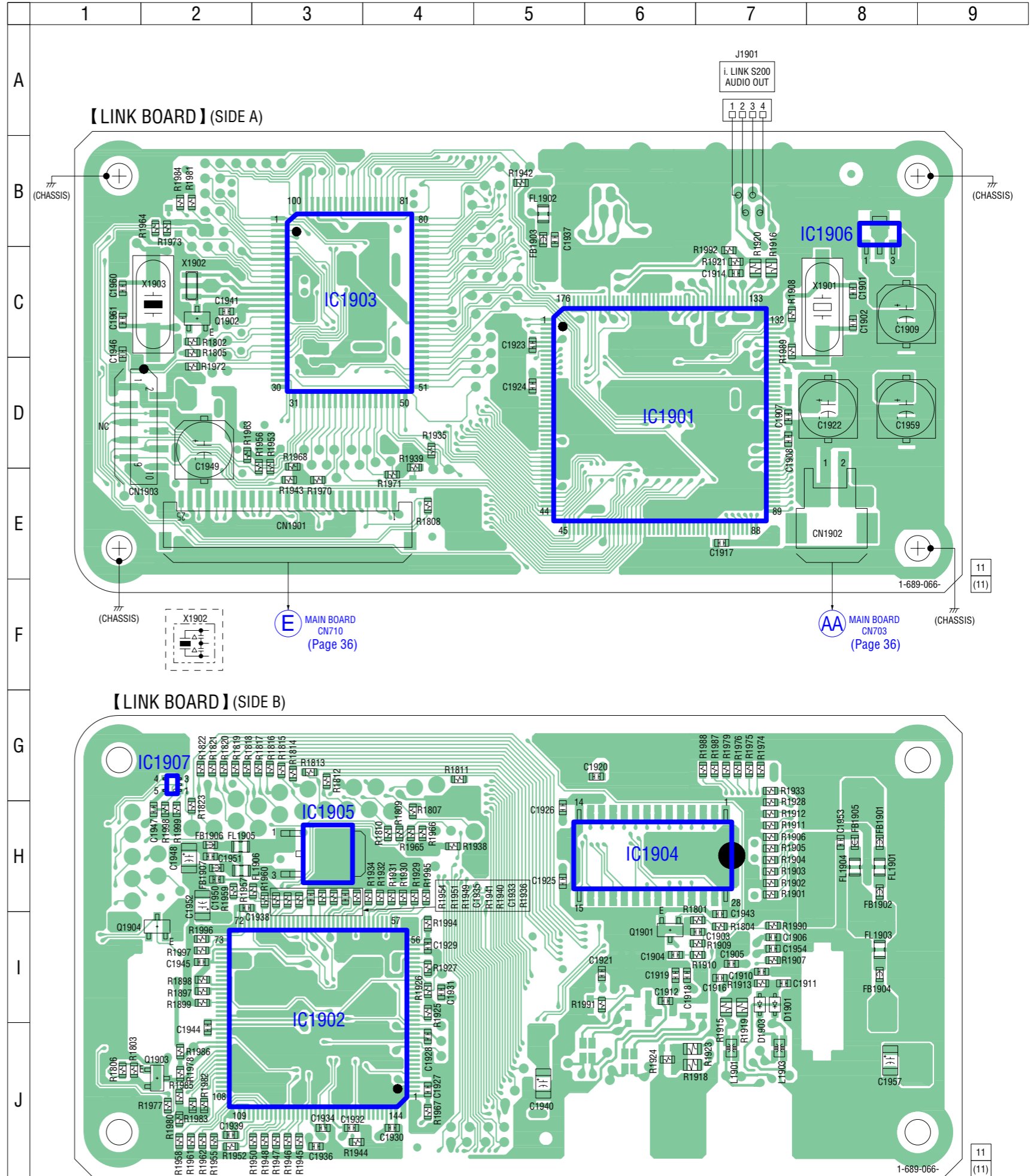

5-35. PRINTED WIRING BOARDS – PANEL Section – • See page 33 for Circuit Boards Location.  :Uses unleaded solder.

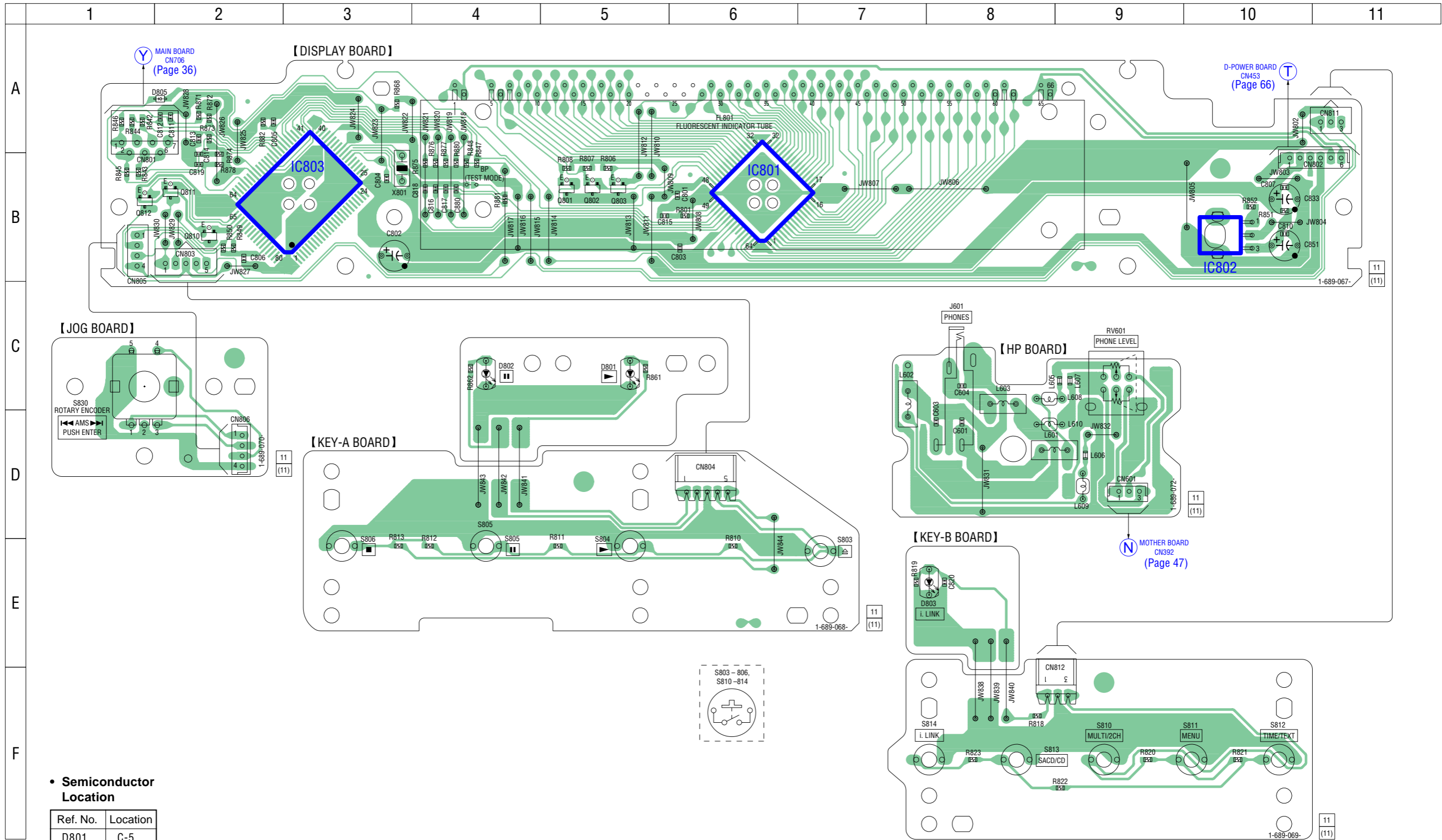

• Semiconductor Location

Ref. No.	Location
D801	C-5
D802	C-4
D803	E-8
D805	A-2
IC801	B-6
IC802	B-10
IC803	B-3
Q801	B-5
Q802	B-5
Q803	B-5
Q810	B-2
Q811	B-2
Q812	B-1

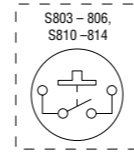

5-36. SCHEMATIC DIAGRAM – PANEL Section (1/2) – • See page 70 for Waveforms.

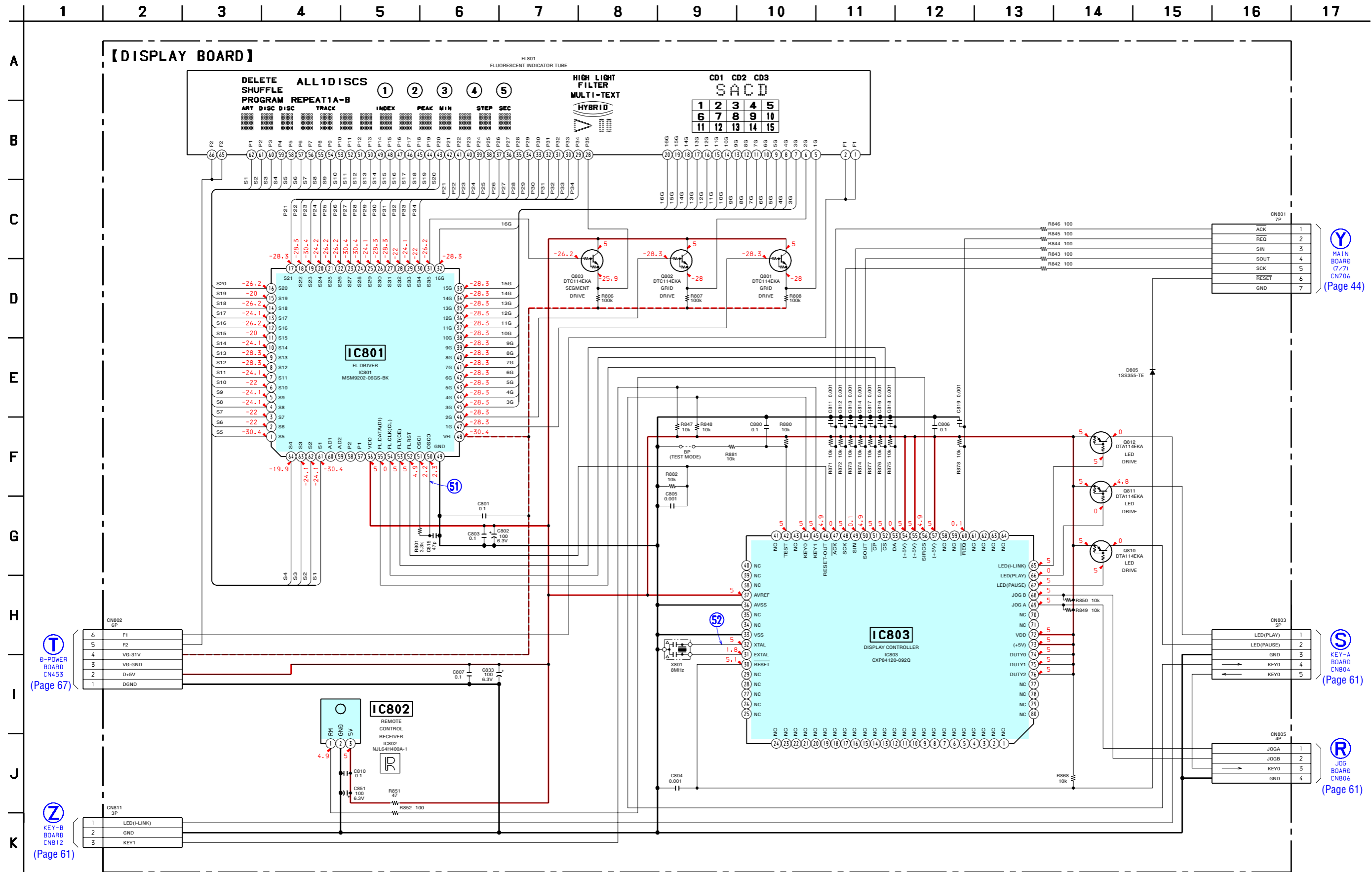

5-37. SCHEMATIC DIAGRAM – PANEL Section (2/2) –

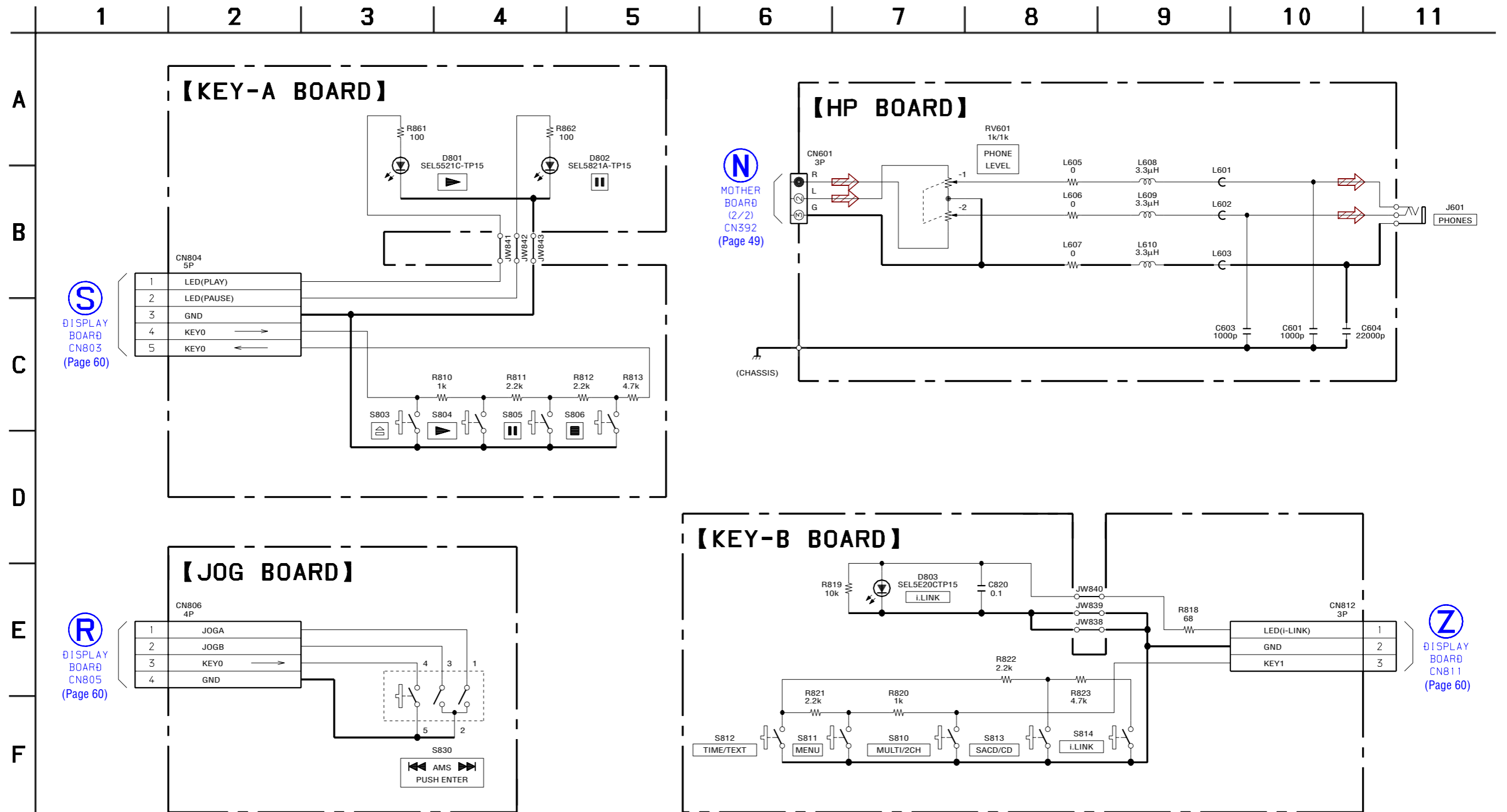

5-38. PRINTED WIRING BOARD – A-POWER Board (Component Side) – • See page 33 for Circuit Boards Location.  :Uses unleaded solder.

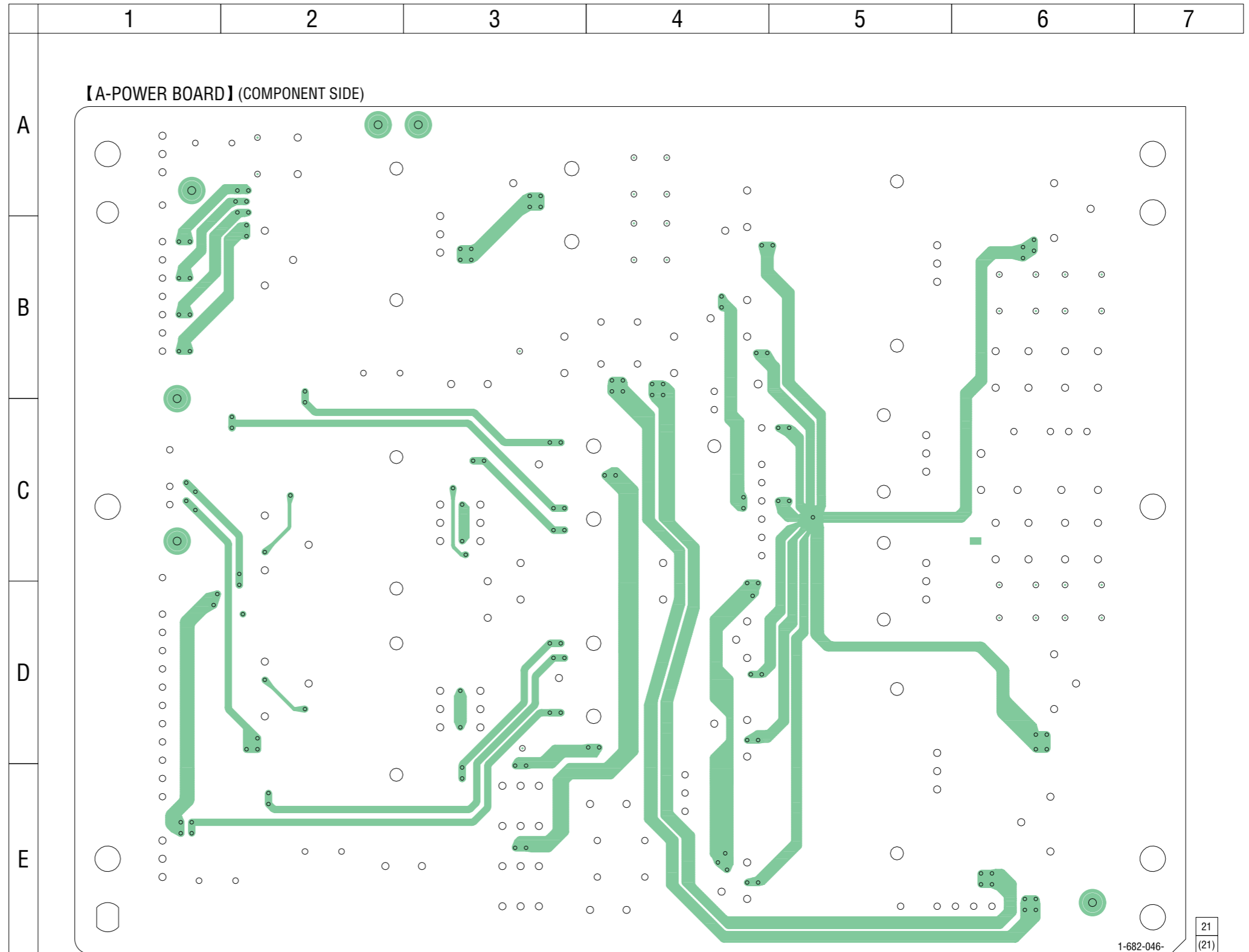

5-39. PRINTED WIRING BOARDS – A-POWER (Conductor Side)/IC Boards – • See page 33 for Circuit Boards Location.  :Uses unleaded solder.

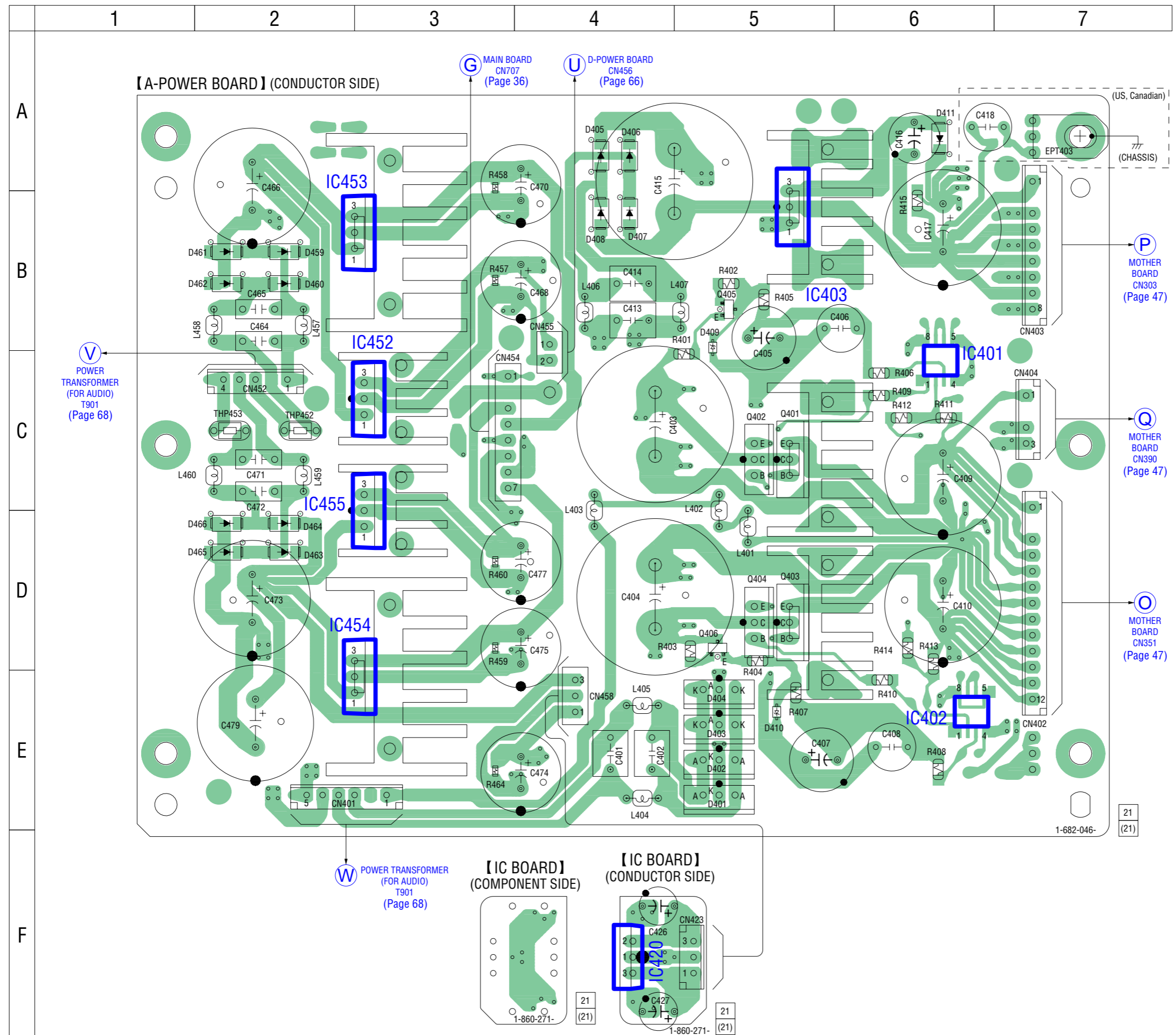

• Semiconductor Location

Ref. No.	Location
D401	E-5
D402	E-5
D403	E-5
D404	E-5
D405	A-4
D406	A-4
D407	B-4
D408	B-4
D409	B-5
D410	E-5
D411	A-6
D459	B-2
D460	B-2
D461	B-2
D462	B-2
D463	D-2
D464	D-2
D465	D-2
D466	D-2
IC401	C-6
IC402	E-6
IC403	B-5
IC420	F-4
IC452	C-3
IC453	B-3
IC454	E-3
IC455	D-3
Q401	C-5
Q402	C-5
Q403	D-5
Q404	D-5
Q405	B-5
Q406	D-5

5-40. SCHEMATIC DIAGRAM – A-POWER/IC Boards –

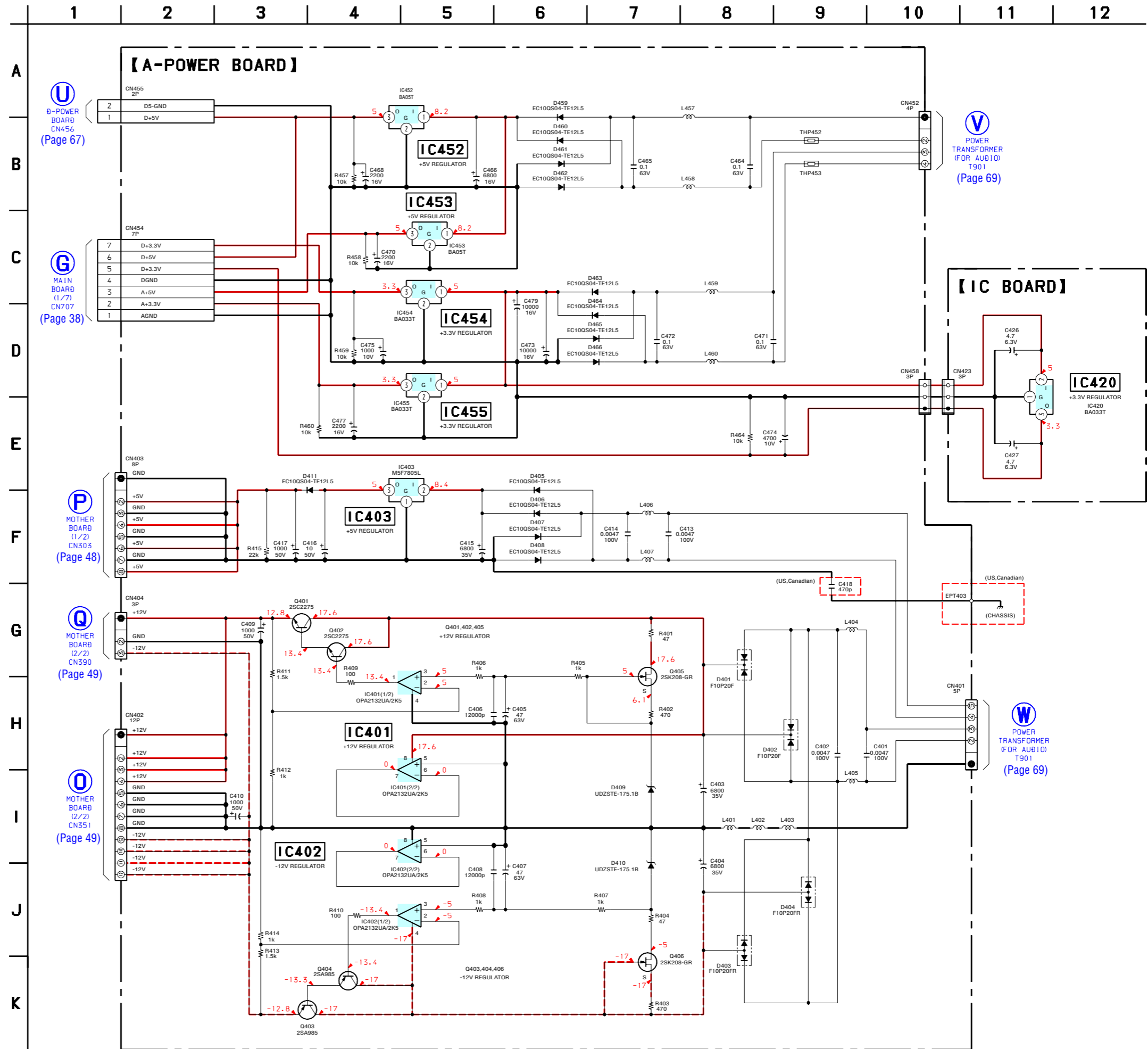

• Waveforms
– RF Board –

① IC001 ③⑨ (TE) (CD Play)

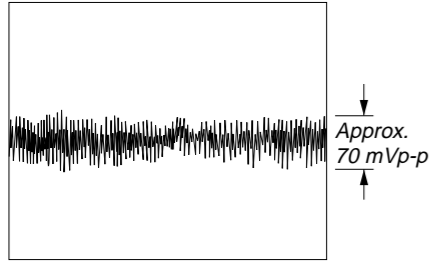

⑤ IC001 ⑤⑦ (RFAC) (CD Play)

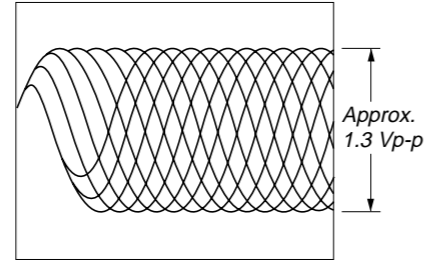

⑬ IC509 ④① (TE) (CD Play)

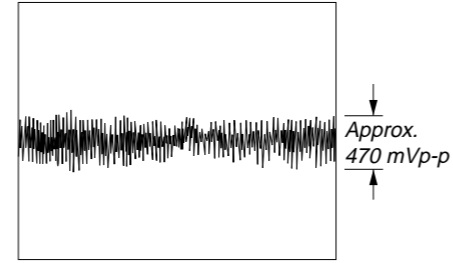

⑮ IC509 ⑤⑦ (BCK) (CD Play)

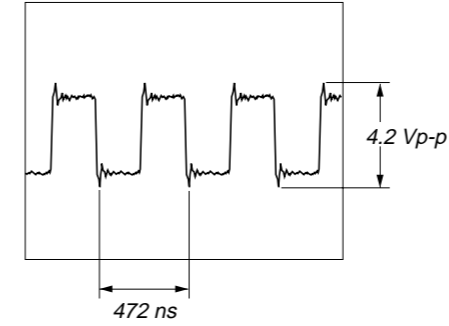

⑲ IC802 ⑩ (PHRI)

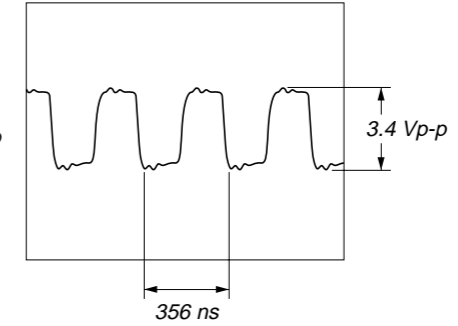

⑳ IC901 ④① (EXTAL)

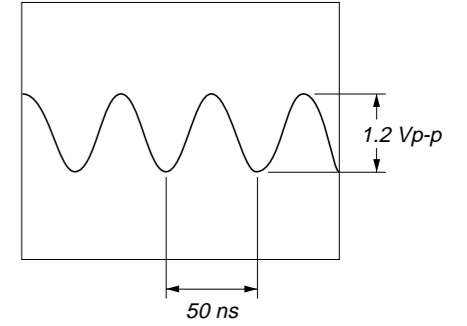

② IC001 ③⑨ (TE) (SACD Play)

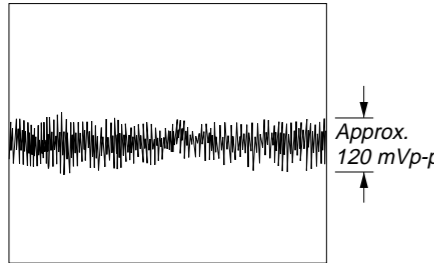

⑥ IC001 ⑤⑦ (RFAC) (SACD Play)

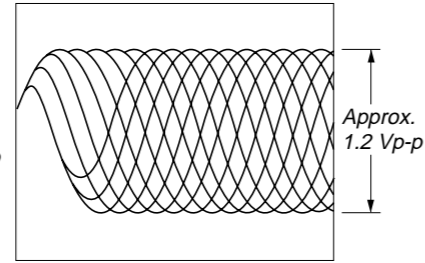

⑭ IC509 ④① (TE) (SACD Play)

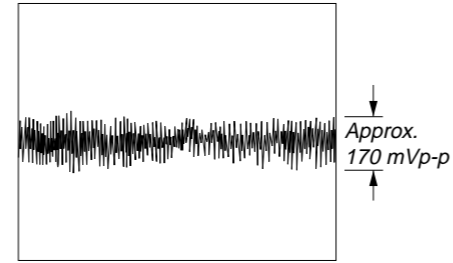

⑰ IC509 ⑤① (XTAI)

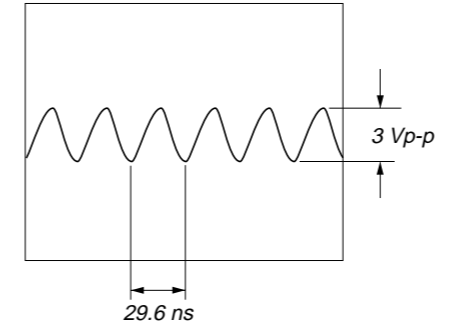

⑳ IC802 ⑩ (BCKAI)

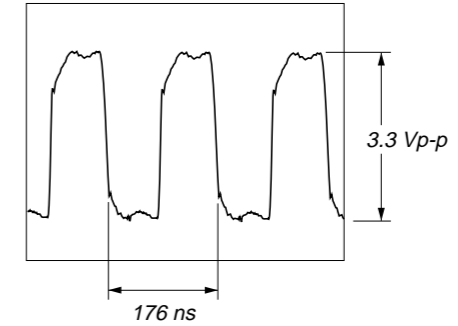

㉑ IC901 ④③ (SPDA)

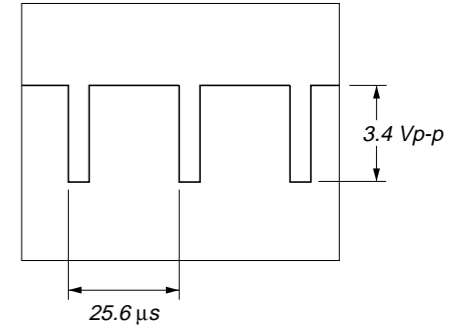

③ IC001 ⑩ (FE) (CD Play)

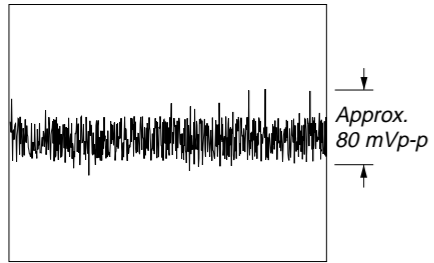

⑮ IC509 ⑤⑥ (RFAC) (CD Play)

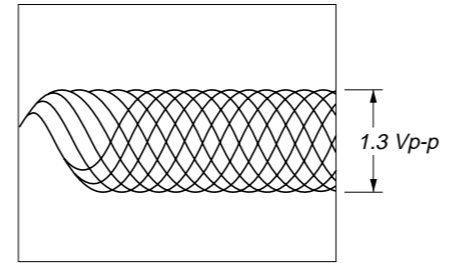

⑳ IC701 ⑩ (XTL2)

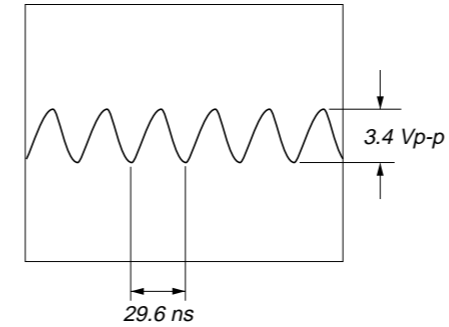

㉑ IC804 ⑬

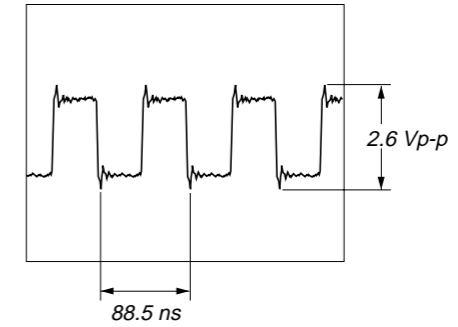

㉒ IC901 ④④ (APDO) (CD Play)

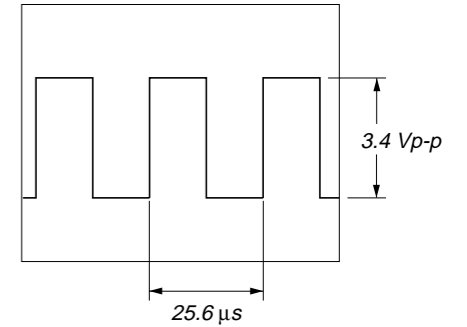

– MAIN Board –

④ IC001 ⑩ (FE) (SACD Play)

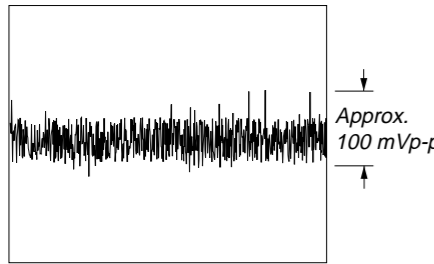

⑪ IC509 ③⑨ (FE) (CD Play)

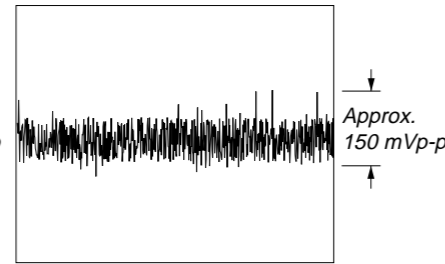

⑯ IC509 ⑤⑥ (RFAC) (SACD Play)

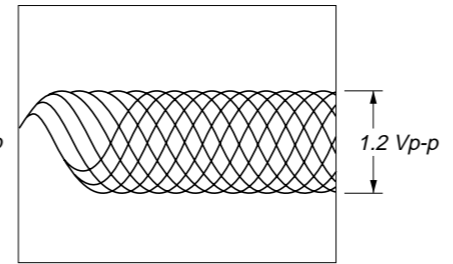

㉑ IC801 ⑩ (WARFI) (CD Play)

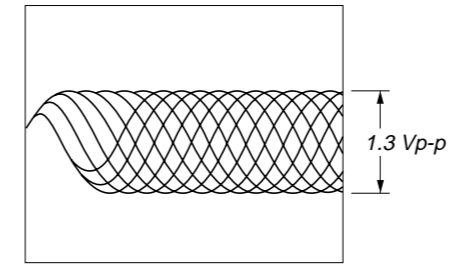

㉒ IC804 ⑥

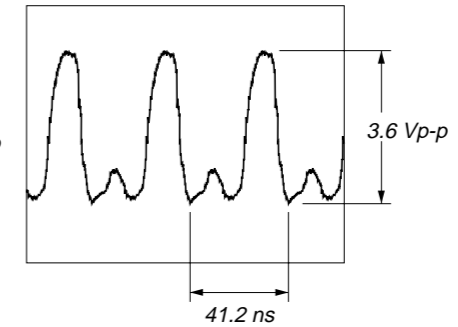

㉓ IC901 ④④ (APDO) (SACD Play)

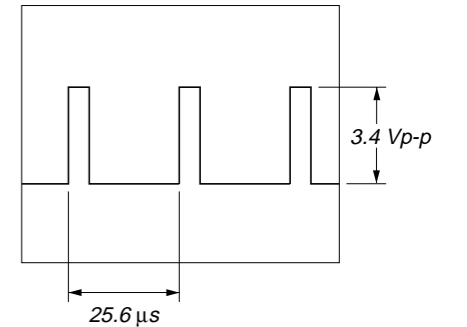

⑫ IC509 ③⑨ (FE) (SACD Play)

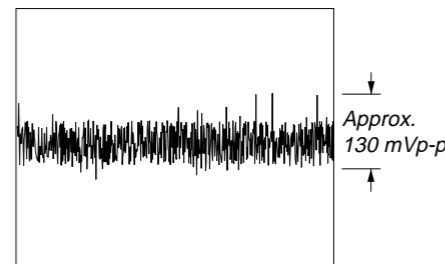

⑰ IC509 ⑤⑤ (LRCK) (CD Play)

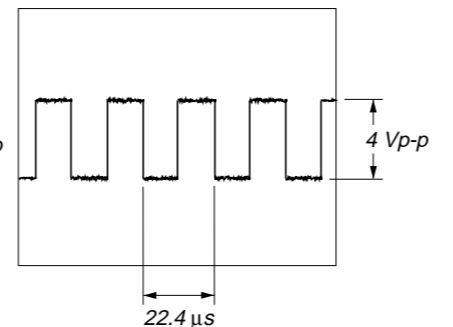

㉒ IC801 ⑩ (WARFI) (SACD Play)

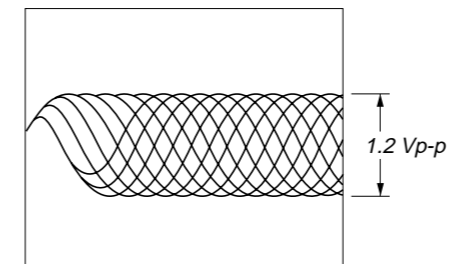

㉓ IC811 ②, ④, ⑥

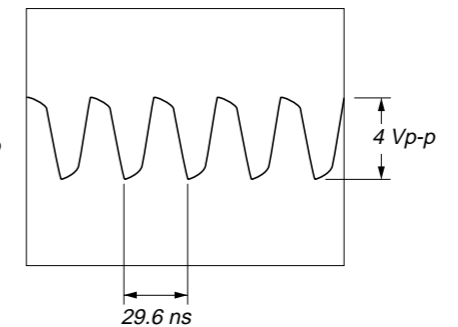

5-41. PRINTED WIRING BOARD – D-POWER Board – • See page 33 for Circuit Boards Location.  :Uses unleaded solder.

• Semiconductor Location

Ref. No.	Location
D421	B-6
D422	C-7
D423	B-6
D451	B-6
D452	B-6
D453	B-6
D454	B-6
D455	C-5
D456	C-5
D457	B-5
D458	B-5
IC451	D-6
Q451	B-7

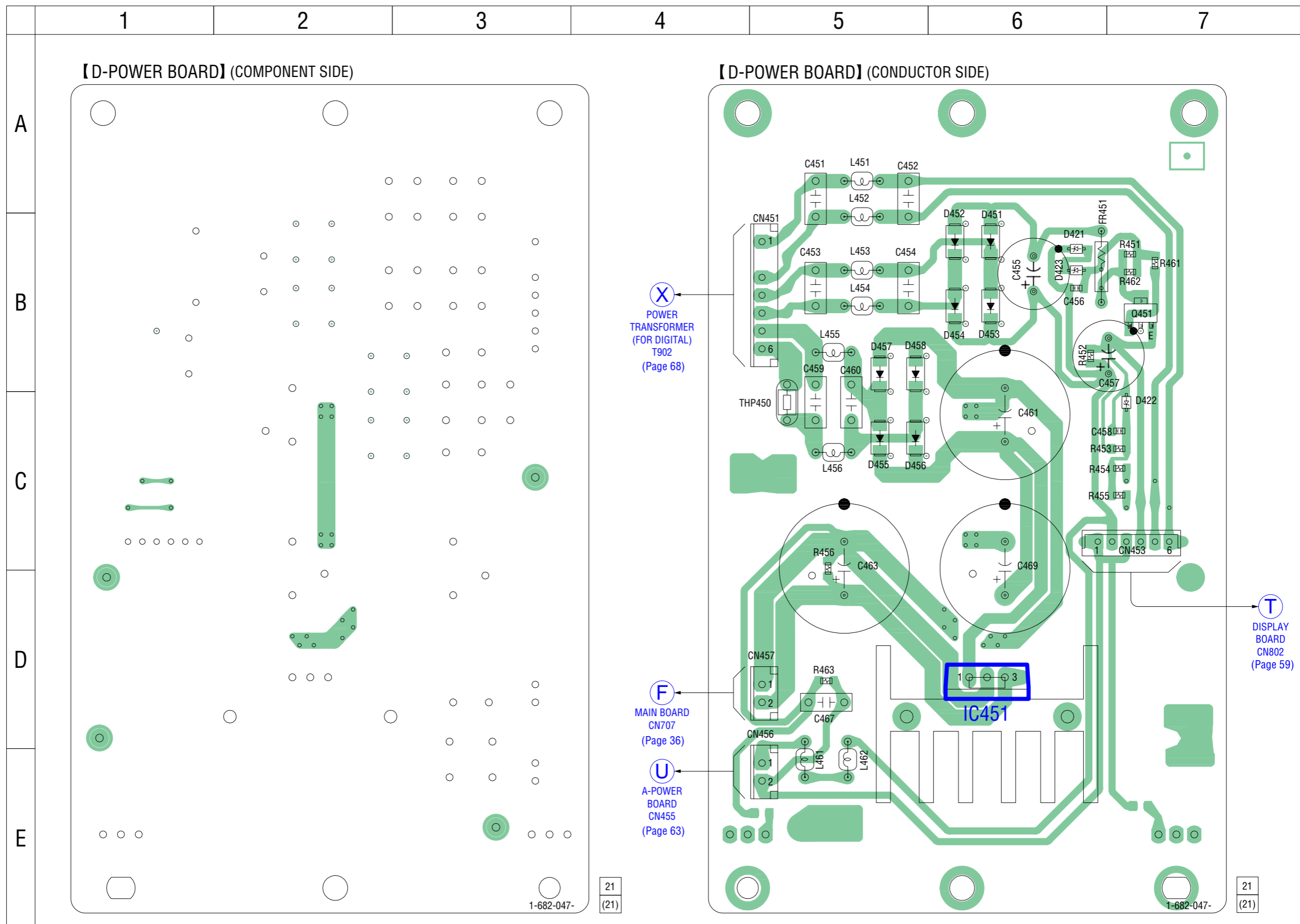

5-42. SCHEMATIC DIAGRAM – D-POWER Board –

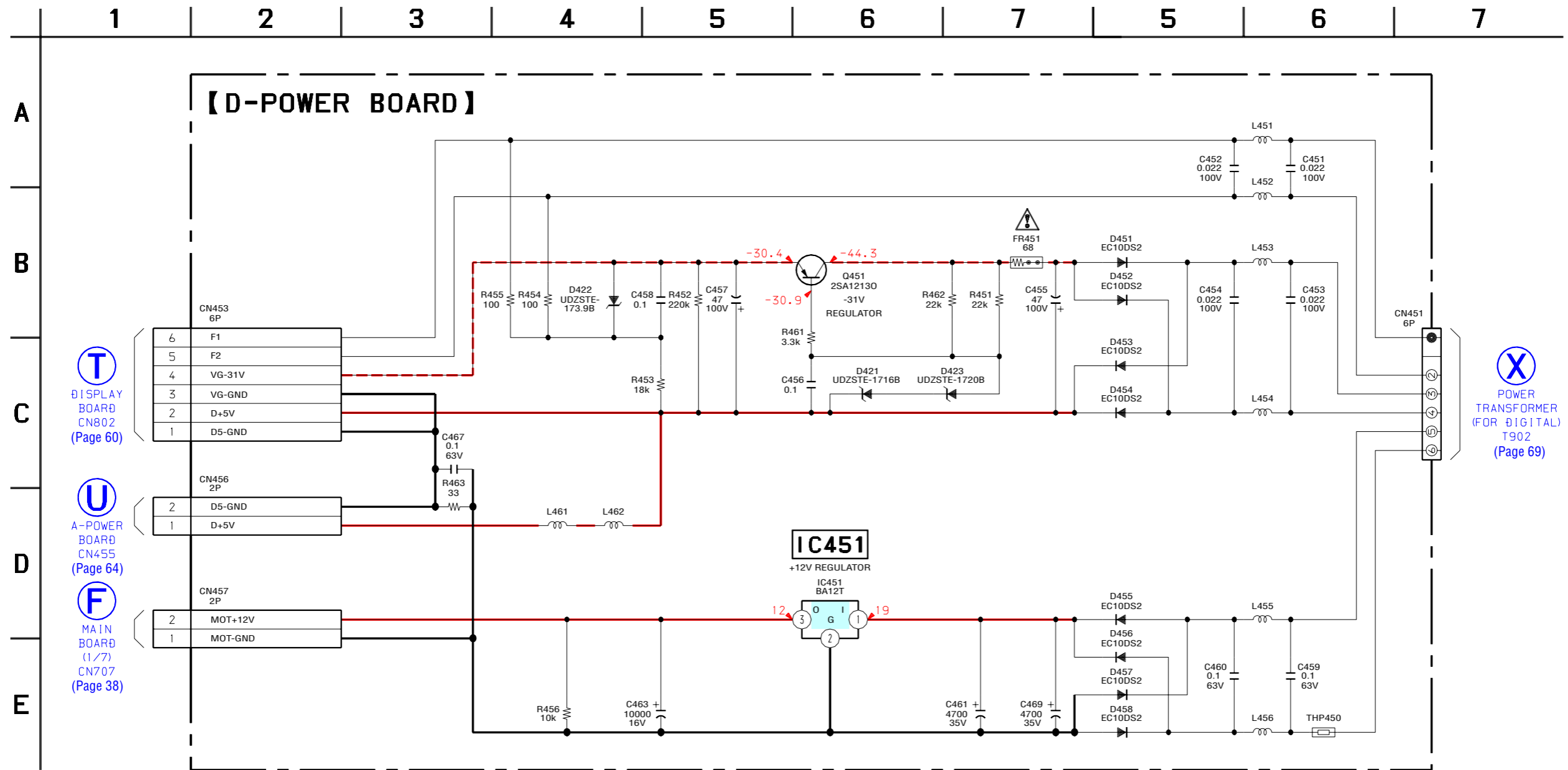

The components identified by mark \triangle or dotted line with mark \triangle are critical for safety. Replace only with part number specified.

Les composants identifiés par une marque \triangle sont critiques pour la sécurité. Ne les remplacer que par une pièce portant le numéro spécifié.

5-43. PRINTED WIRING BOARDS – AC/AC SW Boards – • See page 33 for Circuit Boards Location.  :Uses unleaded solder.

【AC BOARD】 (COMPONENT SIDE)

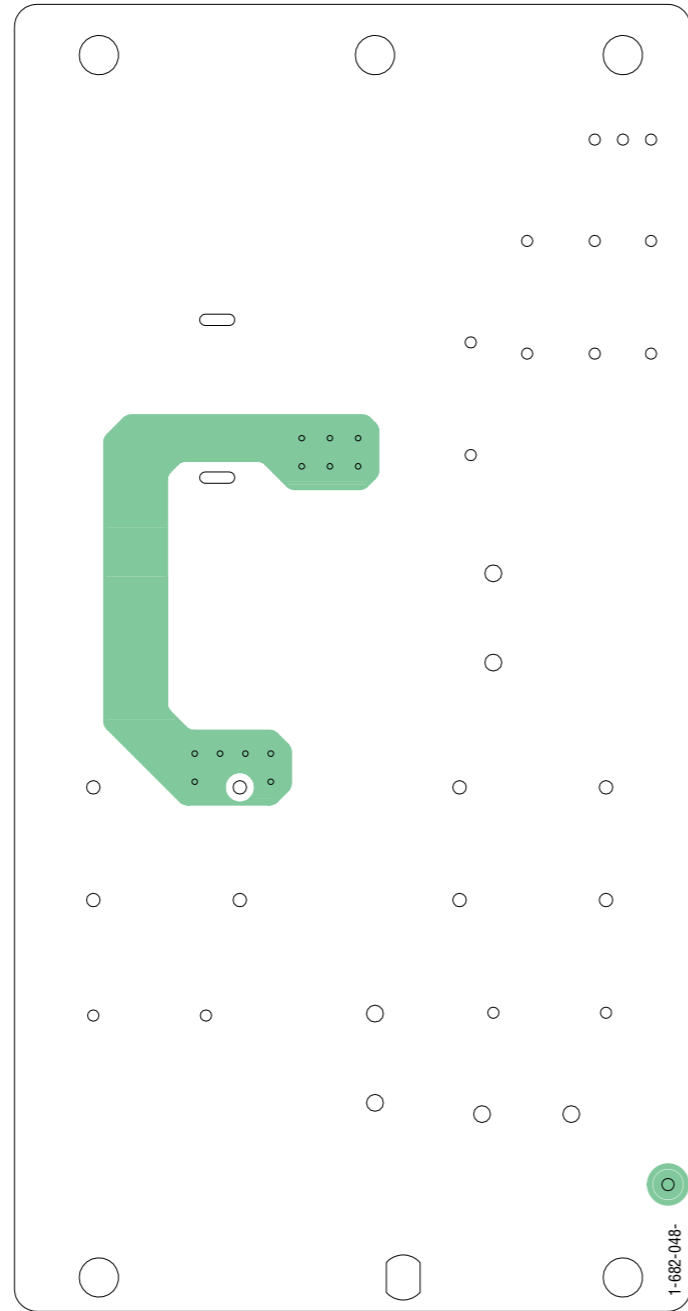

【AC BOARD】 (CONDUCTOR SIDE)

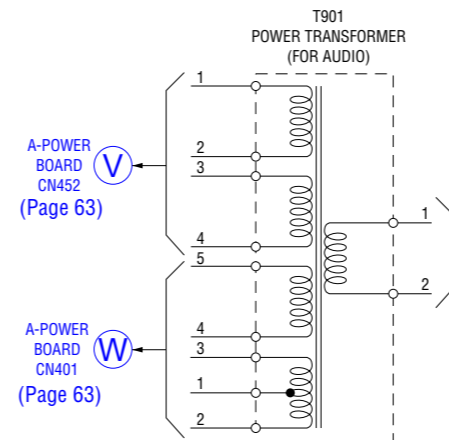
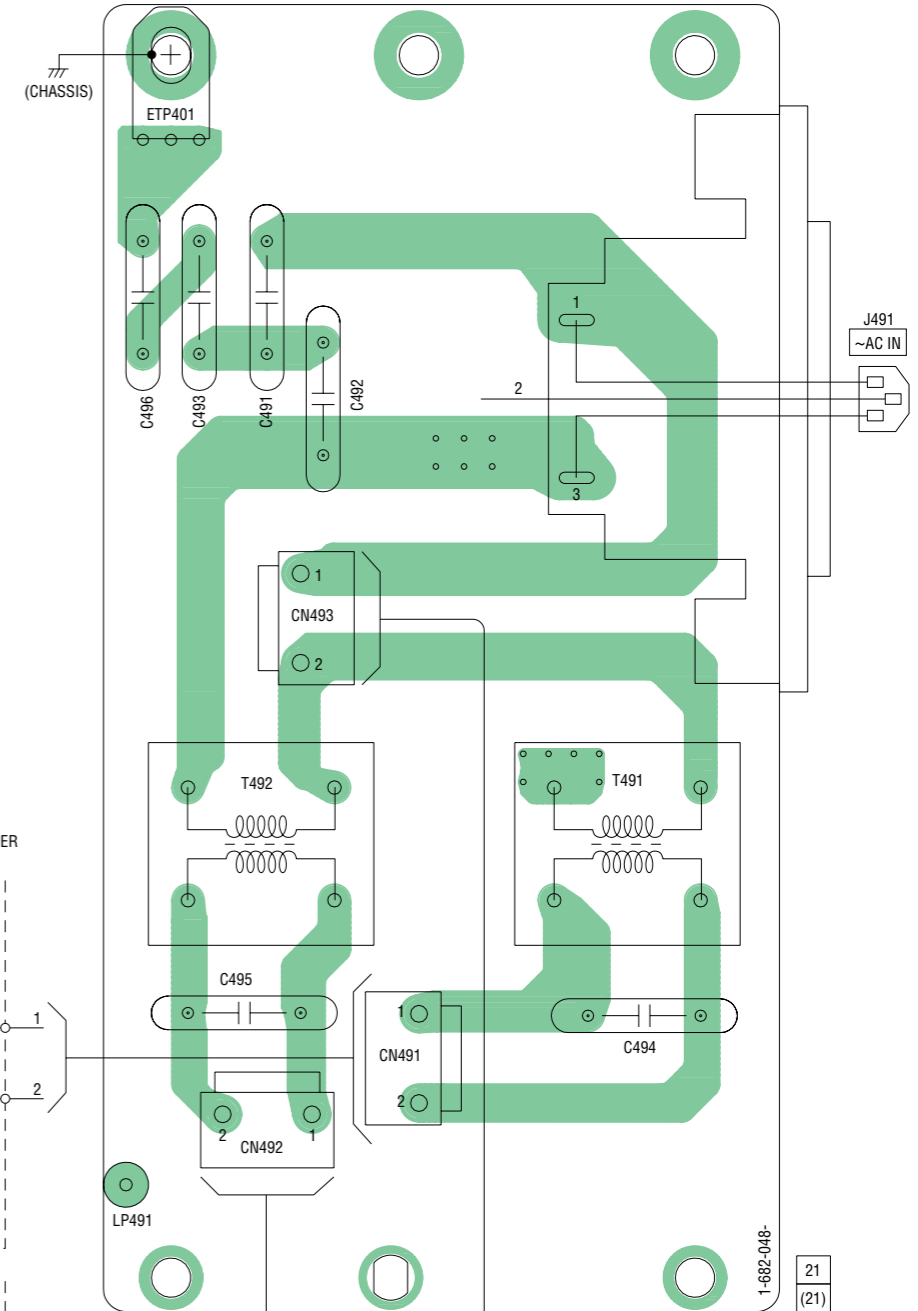

A-POWER BOARD
CN452
(Page 63)

A-POWER BOARD
CN401
(Page 63)

D-POWER BOARD
CN451
(Page 66)

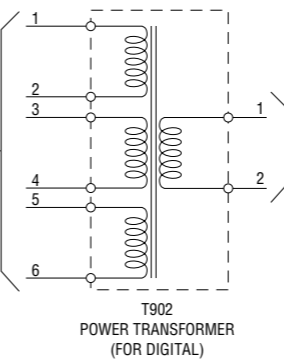

【AC SW BOARD】

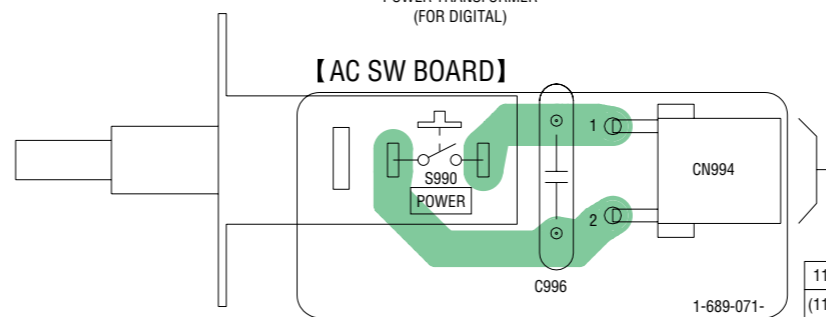

5-44. SCHEMATIC DIAGRAM – AC/AC SW Boards –

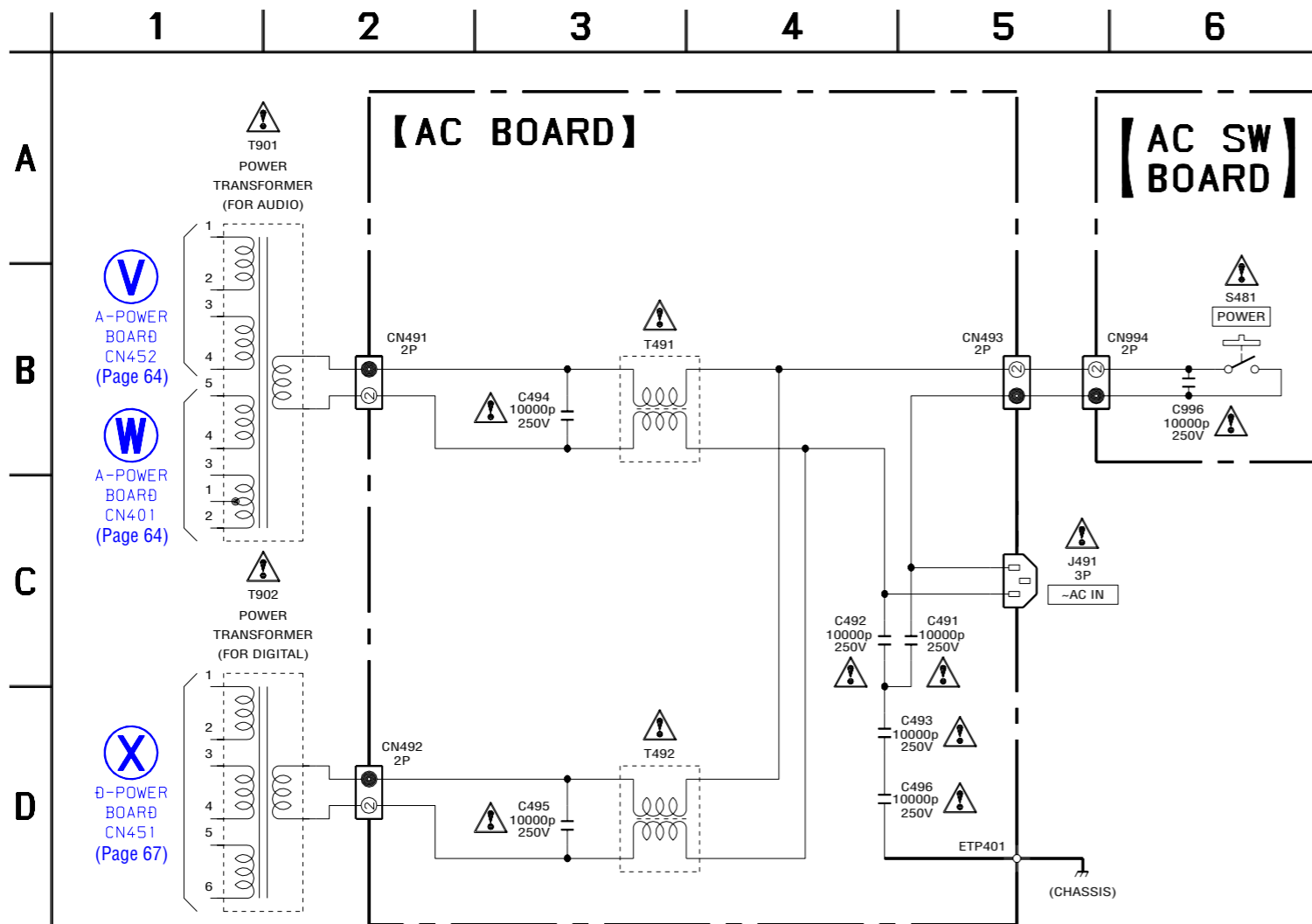

<p>The components identified by mark \triangle or dotted line with mark \triangle are critical for safety. Replace only with part number specified.</p>	<p>Les composants identifiés par une marque \triangle sont critiques pour la sécurité. Ne les remplacer que par une pièce portant le numéro spécifié.</p>
---	--

• Waveforms
– MOTHER Board –

⑰ IC303 ⑭ (QA)

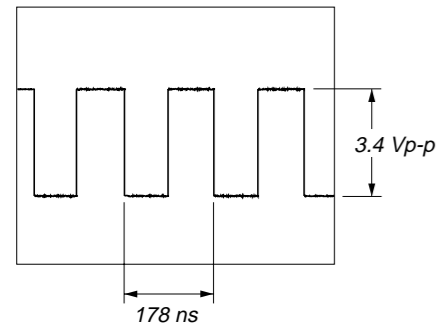

⑱ IC303 ⑬ (QB)

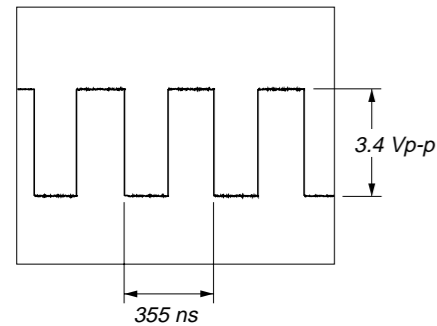

⑲ IC302 ②

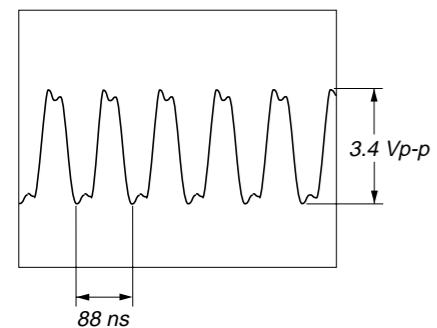

– LINK Board –

④① IC1903 ⑬ (XOUT)

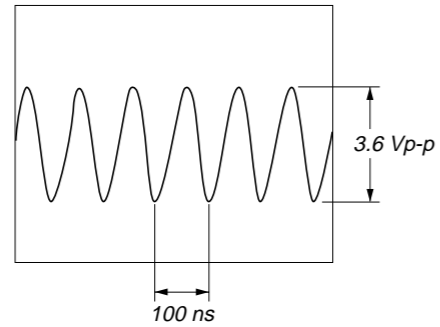

④② IC1902 ⑨⑦ (X2/CLKIN)

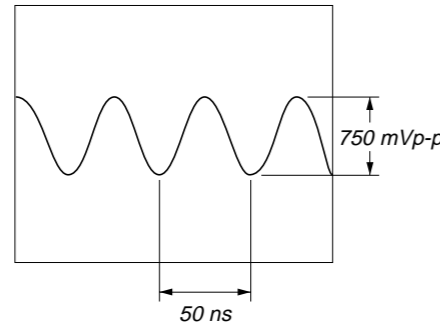

– DISPLAY Board –

⑤① IC801 ⑤① (OSCO)

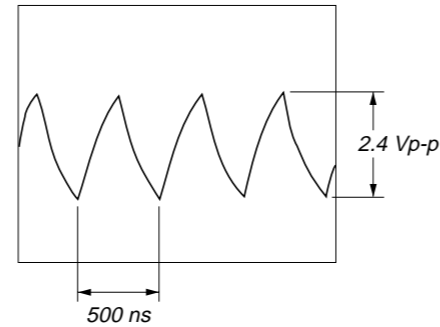

⑤② IC803 ③② (XTAL)

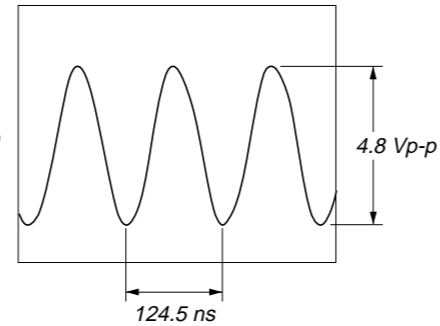

• IC Block Diagrams
– RF Board –

IC001 CXD1881AR-2

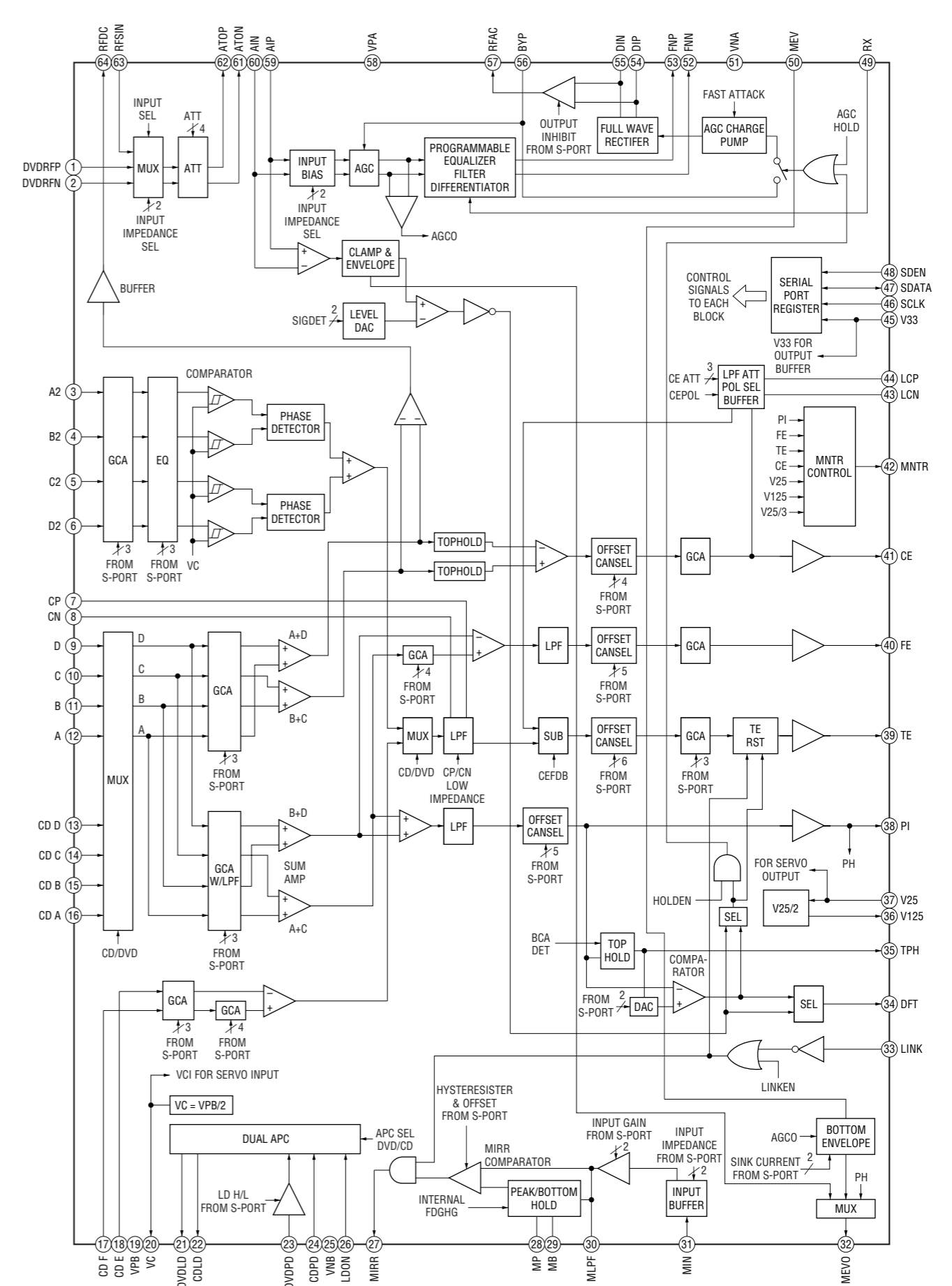

- MAIN Board -

IC509 CXD3068Q

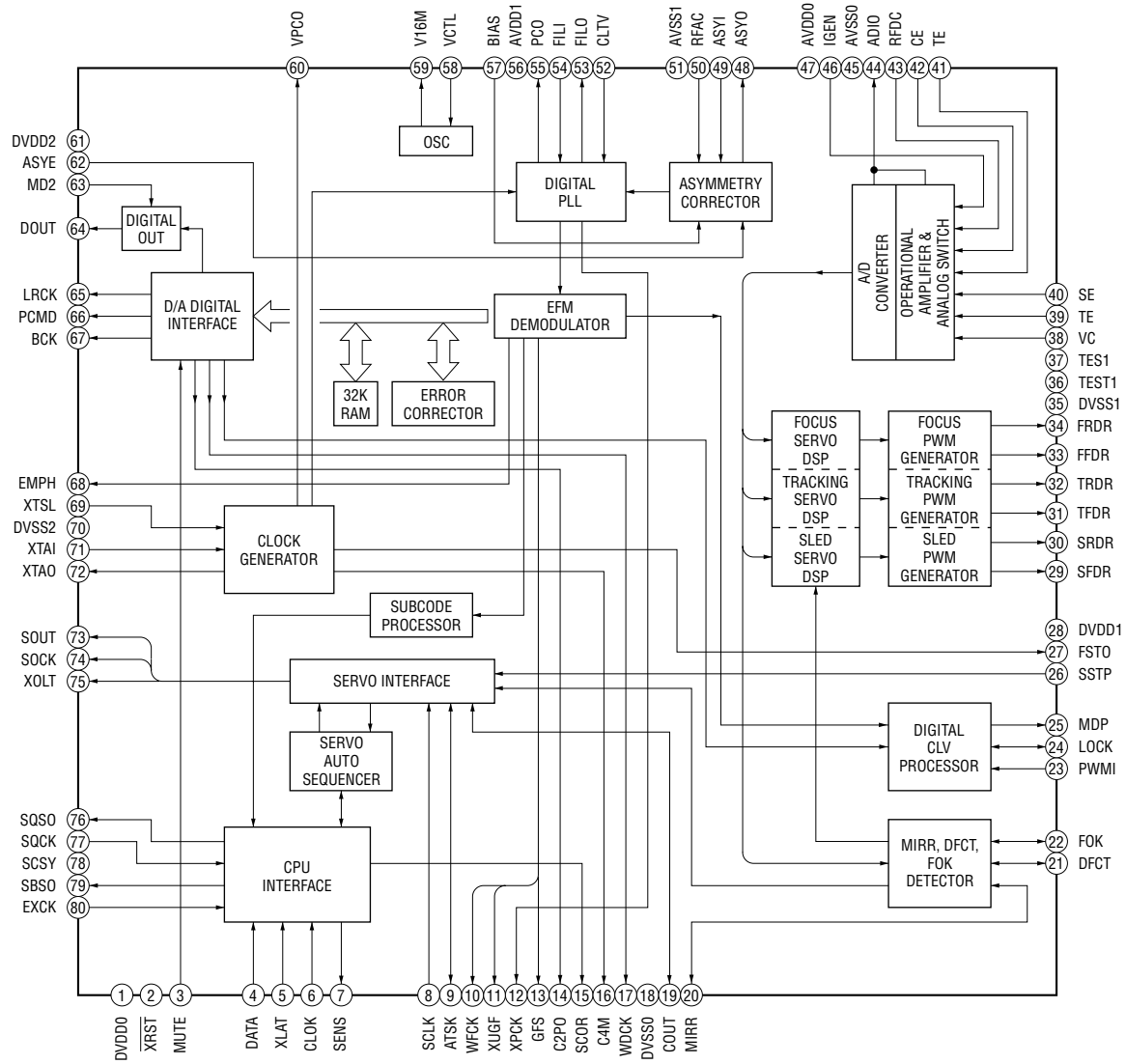

SCD-XA9000ES

IC701 TMC57929PGF-RDP

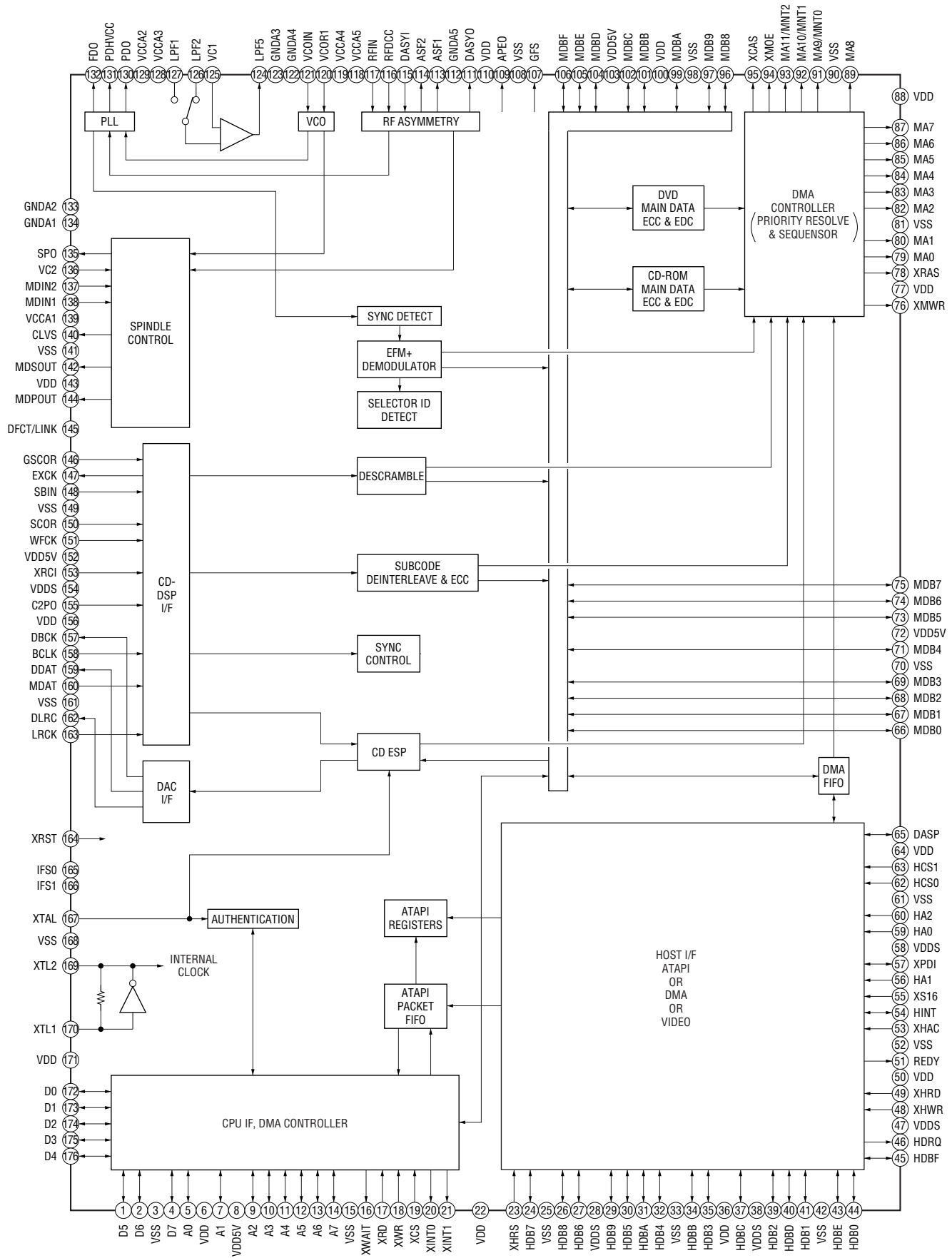

IC902 TC7WH157FU (TE12R)

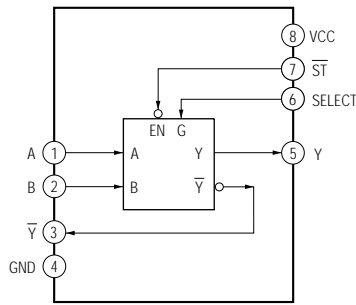

IC905 M51957BFP-600C

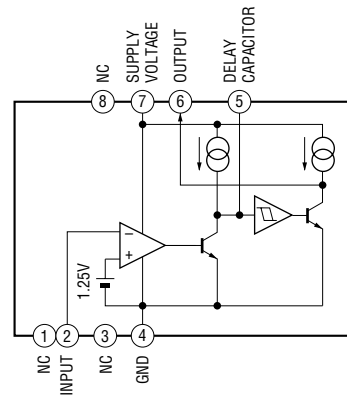

- MOTHER Board -

IC303 HD74LV161ATELL

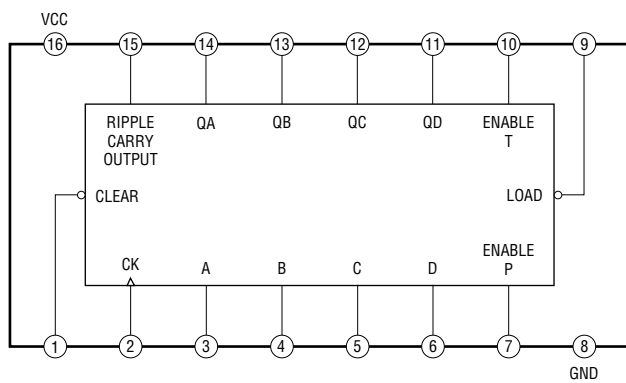

IC304, 305, 306, 307, 308 SN74LV157APWR

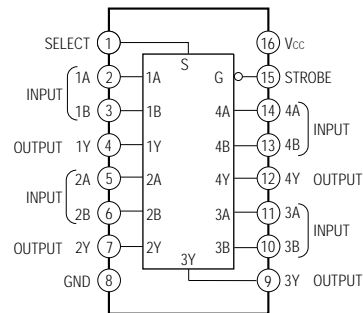

- AUDIO FRONT, AUDIO SURR, AUDIO C/SW Board -

- IC101, 201 (AUDIO FRONT Board)**
- IC1101, 1201 (AUDIO SURR Board)**
- IC2101, 2201 (AUDIO C/SW Board)**
- CXD9657N/2K**

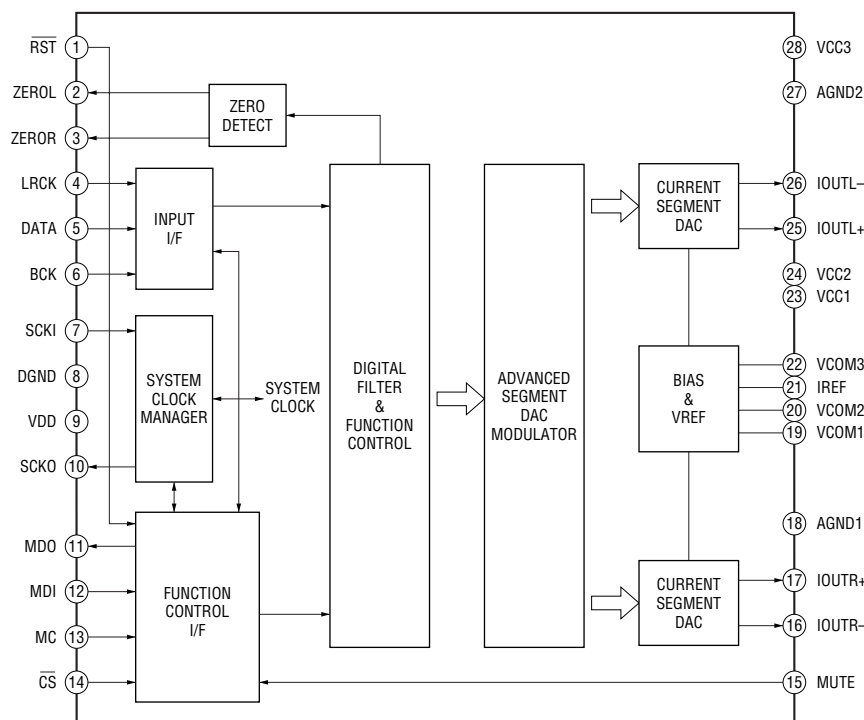

5-45. IC PIN FUNCTION DESCRIPTION

• MAIN BOARD IC509 CXD3068Q

(DIGITAL SERVO PROCESSOR, DIGITAL SIGNAL PROCESSOR, DIGITAL FILTER)

Pin No.	Pin Name	I/O	Description
1	DVDD0	—	Power supply terminal (+3.3V) (digital system)
2	XRST	I	Reset signal input from the I/O expander “L”: reset
3	MUTE	I	Muting on/off control signal input from the CPU “H”: muting on
4	DATA	I	Serial data input from the CPU
5	XLAT	I	Serial data latch pulse signal input from the CPU
6	CLOK	I	Serial data transfer clock signal input from the CPU
7	SENS	O	Internal status (SENSE) signal output to the CPU
8	SCLK	I	SENSE serial data reading clock signal input from the CPU
9	ATSK	I/O	Input/output terminal for anti-shock Not used
10	WFCK	O	Write frame clock signal output to the SACD decoder
11	RFCK	O	RFCK signal output terminal Not used
12	XPCK	O	XPCK signal output terminal Not used
13	GFS	O	Guard frame sync signal output to the CPU
14	C2PO	O	C2 pointer signal output to the SACD decoder
15	SCOR	O	Subcode sync (S0+S1) detection signal output to the SACD decoder and CPU
16	C4M	O	4.2336 MHz clock signal output terminal Not used
17	WDCK	O	Guard subcode sync (S0+S1) detection signal output to the SACD decoder
18	DVSS0	—	Ground terminal (digital system)
19	COUT	O	Numbers of track counted signal output to the CPU
20	MIRR	O	Mirror signal output to the CPU
21	DFCT	O	Defect signal output to the SACD decoder
22	FOK	O	Focus OK signal output to the CPU
23	PWMI	I	Spindle motor external control signal input terminal Not used
24	LOCK	O	GFS is sampled by 460 Hz “H” output when GFS is “H”
25	MDP	O	Spindle motor servo drive signal output to the SACD decoder
26	SSTP	I	Detection signal input from limit in switch The optical pick-up is inner position when “H”
27	FSTO	O	2/3 divider output terminal Not used
28	DVDD1	—	Power supply terminal (+3.3V) (digital system)
29	SFDR	O	Sled servo drive PWM signal (+) output terminal
30	SRDR	O	Sled servo drive PWM signal (-) output terminal
31	TFDR	O	Tracking servo drive PWM signal (+) output terminal
32	TRDR	O	Tracking servo drive PWM signal (-) output terminal
33	FFDR	O	Focus servo drive PWM signal (+) output terminal
34	FRDR	O	Focus servo drive PWM signal (-) output terminal
35	DVSS1	—	Ground terminal (digital system)
36	TEST	I	Input terminal for the test
37	TES1	I	Input terminal for the test
38	VC	I	Middle point voltage (+1.65V) input terminal
39	FE	I	Focus error signal input from the SACD/CD RF amplifier
40	SE	I	Sled error signal input from the SACD/CD RF amplifier
41	TE	I	Tracking error signal input from the SACD/CD RF amplifier
42	CE	I	Middle point servo analog signal input terminal
43	RFDC	I	RF signal input from the SACD/CD RF amplifier
44	ADIO	O	Output terminal for the test Not used
45	AVSS0	—	Ground terminal (analog system)

Pin No.	Pin Name	I/O	Description
46	IGEN	I	Stabilized current input for operational amplifiers
47	AVDD0	—	Power supply terminal (+3.3V) (analog system)
48	ASYO	O	EFM full-swing output terminal
49	ASYI	I	Asymmetry comparator voltage input terminal
50	RFAC	I	EFM signal input from the SACD/CD RF amplifier
51	AVSS1	—	Ground terminal (analog system)
52	CLTV	I	Internal VCO control voltage input terminal
53	FILO	O	Filter output for master PLL
54	FILI	I	Filter input for master PLL
55	PCO	O	Charge pump output for master PLL
56	AVDD1	—	Power supply terminal (+3.3V) (analog system)
57	BIAS	I	Asymmetry circuit constant current input terminal
58	VCTL	I	VCO control voltage input terminal for the wideband EFM PLL Not used
59	V16M	O	VCO oscillation output terminal for the wideband EFM PLL Not used
60	VPCO	O	Charge pump output terminal for the wideband EFM PLL Not used
61	DVDD2	—	Power supply terminal (+3.3V) (digital system)
62	ASYE	I	Asymmetry circuit on/off control signal input terminal “L”: off, “H”: on Fixed at “H” in this set
63	MD2	I	Digital out on/off control signal input from the CPU “L”: digital out off, “H”: digital out on
64	DOUT	O	Digital audio signal output terminal
65	LRCK	O	L/R sampling clock signal (44.1 kHz) output to the SACD decoder and D/A converter
66	PCMD	O	Serial data output to the SACD decoder and D/A converter
67	BCLK	O	Bit clock signal (2.8224 MHz) output to the SACD decoder and D/A converter
68	EMPH	O	“L” is output when playback disc is emphasis off “H” is output when playback disc is emphasis on Not used
69	XTSL	I	Input terminal for the system clock frequency setting “L”: 16.9344 MHz, “H”: 33.8688MHz Fixed at “H” in this set
70	DVSS2	—	Ground terminal (digital system)
71	XTAI	I	System clock input terminal (33.8688 MHz)
72	XTAO	O	System clock output terminal (33.8688 MHz) Not used
73	SOUT	O	Serial data output terminal Not used
74	SOCK	O	Serial data reading clock signal output terminal Not used
75	XOLT	O	Serial data latch pulse signal output terminal Not used
76	SQSO	O	Subcode Q data output to the CPU
77	SQCK	I	Subcode Q data reading clock signal input from the CPU
78	SCSY	I	Input terminal for resynchronism of guard subcode sync (S0+S1) Not used
79	SBSO	O	Subcode serial data output to the SACD decoder
80	EXCK	I	Subcode serial data reading clock signal input to the SACD decoder

• MAIN BOARD IC701 TMC57929PGF-RDP (SACD DECODER)

Pin No.	Pin Name	I/O	Description
1, 2	D5, D6	I/O	Two-way data bus with the CPU and I/O expander
3	VSS	—	Ground terminal (digital system)
4	D7	I/O	Two-way data bus with the CPU and I/O expander
5	A0	I	Address signal input from the CPU
6	VDD	—	Power supply terminal (+3.3V) (digital system)
7	A1	I	Address signal input from the CPU
8	VDD5V	—	Power supply terminal (+5V)
9 to 14	A2 to A7	I	Address signal input from the CPU
15	VSS	—	Ground terminal (digital system)
16	XWAIT	O	Wait signal output terminal Not used
17	XRD	I	Read strobe signal input from the CPU
18	XWR	I	Write strobe signal input from the CPU
19	XCS	I	Chip select signal input from the CPU
20, 21	XINT0, XINT1	O	Interrupt signal output to the CPU
22	VDD	—	Power supply terminal (+3.3V) (digital system)
23	XHRS	I	Not used
24	HDB7	O	Stream data signal output to the DSD decoder
25	VSS	—	Ground terminal (digital system)
26	HDB8	O	Error flag signal output to the DSD decoder
27	HDB6	O	Stream data signal output to the DSD decoder
28	VDDS	—	Power supply terminal (+5V) (digital system)
29	HDB9	O	Not used
30	HDB5	O	Stream data signal output to the DSD decoder
31	HDBA	O	Not used
32	HDB4	O	Stream data signal output to the DSD decoder
33	VSS	—	Ground terminal (digital system)
34	HDBB	O	Not used
35	HDB3	O	Stream data signal output to the DSD decoder
36	VDD	—	Power supply terminal (+3.3V) (digital system)
37	HDBC	O	Not used
38	VDDS	—	Power supply terminal (+5V) (digital system)
39	HDB2	O	Stream data signal output to the DSD decoder
40	HDBD	O	Not used
41	HDB1	O	Stream data signal output to the DSD decoder
42	VSS	—	Ground terminal (digital system)
43	HDBE	O	Not used
44	HDB0	O	Stream data signal output to the DSD decoder
45	HDBF	O	Not used
46	XSAK	O	Serial data effect flag signal output to the DSD decoder
47	VDDS	—	Power supply terminal (+5V) (digital system)
48	XDCK	O	Serial data transfer clock signal output to the DSD decoder
49	XSHD	O	Header flag signal output to the DSD decoder
50	VDD	—	Power supply terminal (+3.3V) (digital system)
51	REDY	O	Not used
52	VSS	—	Ground terminal (digital system)
53	XSRQ	I	Serial data request signal input from the DSD decoder

Pin No.	Pin Name	I/O	Description
54	HINT	O	Not used
55	XS16	O	Not used
56	HA1	I	Not used
57	XPDI	I/O	Not used
58	VDDS	—	Power supply terminal (+5V) (digital system)
59, 60	HA0, HA2	I	Not used
61	VSS	—	Ground terminal (digital system)
62, 63	HCS0, HCS1	I	Not used
64	VDD	—	Power supply terminal (+3.3V) (digital system)
65	DASP	I/O	Not used
66 to 69	MDB0 to MDB3	I/O	Two-way data bus with the D-RAM
70	VSS	—	Ground terminal (digital system)
71	MDB4	I/O	Two-way data bus with the D-RAM
72	VDD5V	—	Power supply terminal (+5V)
73 to 75	MDB5 to MDB7	I/O	Two-way data bus with the D-RAM
76	XMWR	O	Write enable signal output to the D-RAM
77	VDD	—	Power supply terminal (+3.3V) (digital system)
78	XRAS	O	Row address strobe signal output to the D-RAM
79, 80	MA0, MA1	O	Address signal output to the D-RAM
81	VSS	—	Ground terminal (digital system)
82 to 87	MA2 to MA7	O	Address signal output to the D-RAM
88	VDD	—	Power supply terminal (+3.3V) (digital system)
89	MA8	O	Address signal output to the D-RAM
90	VSS	—	Ground terminal (digital system)
91	MA9	O	Address signal output to the D-RAM
92	MA10	O	RF data signal output terminal Not used
93	MA11	O	Operation clock signal output for PSP physical disc mark detection to DSD decoder
94	XMOE	O	Output enable signal output to the D-RAM
95	XCAS	O	Column address strobe signal output to the D-RAM
96, 97	MDB8, MDB9	I/O	Two-way data bus with the D-RAM
98	VSS	—	Ground terminal (digital system)
99	MDBA	I/O	Two-way data bus with the D-RAM
100	VDD	—	Power supply terminal (+3.3V) (digital system)
101, 102	MDBB, MDBC	I/O	Two-way data bus with the D-RAM
103	VDD5V	—	Power supply terminal (+5V)
104 to 106	MDBD to MDBF	I/O	Two-way data bus with the D-RAM
107	GFS	O	Guard frame sync signal output to the CPU
108	VSS	—	Ground terminal (digital system)
109	APEO	O	Absolute phase error signal output terminal
110	VDD	—	Power supply terminal (+3.3V) (digital system)
111	DASYO	O	RF binary signal output terminal
112	GNDA5	—	Ground terminal (analog system)
113, 114	ASF1, AFS2	—	Filter connected terminal for selection the constant asymmetry compensation
115	DASYI	I	Analog signal input after integrated from the RF binary signal
116	RFDCC	I	Input terminal for adjusting DC cut high-pass filter for RF signal Not used
117	RFIN	I	RF signal input from the SACD/CD RF amplifier
118, 119	VCCA5, VCCA4	—	Power supply terminal (+3.3V) (analog system)

SCD-XA9000ES

Pin No.	Pin Name	I/O	Description
120	VCOR1	—	VCO oscillating range setting resistor connected terminal
121	VCOIN	I	VCO input terminal
122, 123	GND4, GND43	—	Ground terminal (analog system)
124	LPF5	O	Signal output from the operation amplifier from PLL loop filter
125	VC1	I	Middle point voltage (+1.65V) input terminal
126, 127	LPF2, LPF1	I	Inverted signal input to the operation amplifier from PLL loop filter
128, 129	VCCA3, VCCA2	—	Power supply terminal (+3.3V) (analog system)
130	PDO	O	Signal output from the charge pump for phase comparator
131	PDHVCC	I	Middle point voltage input terminal for RF PLL
132	FDO	O	Signal output from the charge pump for frequency comparator
133, 134	GND2, GND1	—	Ground terminal (analog system)
135	SPO	O	Spindle motor control signal output terminal
136	VC2	I	Middle point voltage (+1.65V) input terminal
137	MDIN2	I	Spindle motor servo drive signal input terminal
138	MDIN1	I	MDP input terminal
139	VCCA1	—	Power supply terminal (+3.3V) (analog system)
140	CLVS	O	Control signal output for selection the spindle control filter constant at CLVS
141	VSS	—	Ground terminal (digital system)
142	MDSOUT	O	Frequency error output terminal of internal CLV circuit
143	VDD	—	Power supply terminal (+3.3V) (digital system)
144	MDPOUT	O	Phase error output terminal of internal CLV circuit
145	DEFECT	I	Defect signal input from the digital signal processor
146	GSCOR	I	Guard subcode sync (S0+S1) detection signal input from the digital signal processor
147	EXCK	O	Subcode serial data reading clock signal output to the digital signal processor
148	SBIN	I	Subcode serial data input from the digital signal processor
149	VSS	—	Ground terminal (digital system)
150	SCOR	I	Subcode sync (S0+S1) detection signal input from the digital signal processor
151	WFCK	I	Write frame clock signal input from the digital signal processor
152	VDD5V	—	Power supply terminal (+5V)
153	XRCI	I	RAM overflow signal input terminal Not used
154	VDDS	—	Power supply terminal (+5V) (digital system)
155	C2PO	I	C2 pointer signal input from the digital signal processor
156	VDD	—	Power supply terminal (+3.3V) (digital system)
157	DBCK	O	Bit clock signal (2.8224 MHz) output terminal Not used
158	BCLK	I	Bit clock signal (2.8224 MHz) input from the digital signal processor
159	DDAT	O	PCM data output terminal Not used
160	MDAT	I	Serial data input from the digital signal processor
161	VSS	—	Ground terminal (digital system)
162	DLRC	O	L/R sampling clock signal (44.1 kHz) output terminal Not used
163	LRCK	I	L/R sampling clock signal (44.1 kHz) input from the digital signal processor
164	XRST	I	Reset signal input from the I/O expander “L”: reset
165	IFS0	I	Interface selection signal input terminal Fixed at “L” in this set
166	IFS1	I	Interface selection signal input terminal Fixed at “H” in this set
167	XTAL	I	33.8688 MHz clock signal input terminal
168	VSS	—	Ground terminal (digital system)
169	XTA2	O	System clock output terminal (33.8688 MHz)
170	XTA1	I	System clock input terminal (33.8688 MHz)

Pin No.	Pin Name	I/O	Description
171	VDD	—	Power supply terminal (+3.3V) (digital system)
172 to 176	D0 to D4	I/O	Two-way data bus with the CPU and I/O expander

• MAIN BOARD IC801 CXD2753R (DSD DECODER)

Pin No.	Pin Name	I/O	Description
1	VSCA0	—	Ground terminal (for core)
2	XMSLAT	I	Serial data latch pulse signal input from the CPU
3	MSCK	I	Serial data transfer clock signal input from the CPU
4	MSDATI	I	Serial data input from the CPU
5	VDCA0	—	Power supply terminal (+2.5V) (for core)
6	MSDATO	O	Serial data output to the CPU
7	MSREADY	O	Ready signal output to the CPU “L”: ready
8	XMSDOE	O	Serial data output enable signal output terminal Not used
9	XRST	I	Reset signal input from the I/O expander “L”: reset
10	SMUTE	I	Soft muting on/off control signal input from the CPU “H”: muting on
11	MCKI	I	Master clock signal (33.8688 MHz) input terminal
12	VSIOA0	—	Ground terminal (for I/O)
13	EXCKO1	O	External clock 1 signal output terminal Not used
14	EXCKO2	O	External clock 2 signal output terminal Not used
15	LRCK	O	L/R sampling clock signal (44.1 kHz) output terminal Not used
16	F75HZ	O	Not used
17	VDIOA0	—	Power supply terminal (+3.3V) (for I/O)
18 to 25	MNT0 to MNT7	O	Monitor signal output terminal Not used
26	TCK	I	Clock signal input terminal for the test (normally: fixed at “L”)
27	TDI	I	Input terminal for the test (normally: open)
28	VSCA1	—	Ground terminal (for core)
29	TDO	O	Output terminal for the test (normally: open)
30	TMS	I	Input terminal for the test (normally: open)
31	TRST	I	Reset terminal for the test (normally: fixed at “L”)
32 to 34	TEST1 to TEST3	I	Input terminal for the test (normally: fixed at “L”)
35	VDCA1	—	Power supply terminal (+2.5V) (for core)
36	UBIT	O	Monitor terminal relative to DST Not used
37	XBIT	O	Monitor terminal relative to DST Not used
38 to 41	SUPDT0 to SUPDT3	O	Supplementary data output terminal Not used
42	VSIOA1	—	Ground terminal (for I/O)
43, 44	SUPDT4, SUPDT5	O	Supplementary data output terminal Not used
45	VDIOA1	—	Power supply terminal (+3.3V) (for I/O)
46, 47	SUPDT6, SUPDT7	O	Supplementary data output terminal Not used
48	SUPEN	O	Supplementary data enable signal output terminal Not used
49	VSCA2	—	Ground terminal (for core)
50	DSAEXR	O	Not used
51, 52	TEST4, TEST5	I	Input terminal for the test (normally: fixed at “L”)
53	NC	O	Not used
54	VDCA2	—	Power supply terminal (+2.5V) (for core)
55	DSADML	O	DSD data output terminal for L-ch down mix Not used
56	DSADMR	O	DSD data output terminal for R-ch down mix Not used
57	BCKASL	I	Input/output selection signal input terminal of bit clock signal (2.8224 MHz) for DSD data output “L”: input (slave), “H”: output (master) Fixed at “L” in this set
58	VSDSD0	—	Ground terminal (for DSD data output)
59	BCKAI	I	Clock signal (5.6448 MHz) input terminal

Pin No.	Pin Name	I/O	Description
60	BCKAO	O	Bit clock signal (2.8224 MHz) output terminal for DSD data output Not used
61	PHREFI	I	Clock signal (2.8224 MHz) input terminal
62	PHREFO	O	Phase reference signal output terminal for DSD output phase modulation Not used
63	ZDFL	O	Front L-ch Zero data flag detection signal output terminal Not used
64	DSAL	O	Front L-ch DSD data output to the DSD digital signal processor
65	ZDFR	O	Front R-ch Zero data flag detection signal output terminal Not used
66	DSAR	O	Front R-ch DSD data output to the DSD digital signal processor
67	VDDSD0	—	Power supply terminal (+3.3V) (for DSD data output)
68	ZDFC	O	Center zero data flag detection signal output terminal Not used
69	DSAC	O	Center DSD data output to the DSD digital signal processor
70	ZDFLFE	O	Sub woofer zero data flag detection signal output terminal Not used
71	DSASW	O	Sub woofer DSD data output to the DSD digital signal processor
72	VSDSD1	—	Ground terminal (for DSD data output)
73	ZDFLS	O	Surround L-ch zero data flag detection signal output terminal Not used
74	DSALS	O	Surround L-ch DSD data output to the DSD digital signal processor
75	ZDFRS	O	Surround R-ch zero data flag detection signal output terminal Not used
76	DSARS	O	Surround R-ch DSD data output to the DSD digital signal processor
77	VDDSD1	—	Power supply terminal (+3.3V) (For DSD data output)
78, 79	IOUT0, IOUT1	I/O	Two-way data bus with the i-link interface
80	VSCB0	—	Ground terminal (for core)
81, 82	IOUT2, IOUT3	I/O	Two-way data bus with the i-link interface
83	VDCB0	—	Power supply terminal (+2.5V) (for core)
84, 85	IOUT4, IOUT5	I/O	Two-way data bus with the i-link interface
86	VSI0B0	—	Ground terminal (for I/O)
87	IANCO	O	Transmission information data output to the i-link interface
88	IFULL	I	Data transmission hold request signal input from the i-link interface
89	IEMPTY	I	High speed transmission request signal input from the i-link interface
90	VDIOB0	—	Power supply terminal (+3.3V) (for I/O)
91	IFRM	O	Frame reference signal output to the i-link interface
92	IOUTE	O	Enable signal output to the i-link interface
93	IBCK	O	Data transmission clock signal output to the i-link interface
94	VSCB1	—	Ground terminal (for core)
95	IERR	I	Not used
96	IANCI	I	Not used
97	IPLAN	I	Not used
98	IHOLD	O	Not used
99	VDCB1	—	Power supply terminal (+2.5V) (for core)
100	IVLD	I	Not used
101 to 105	IDIN0 to IDIN4	I	Not used
106	VSI0B1	—	Ground terminal (for I/O)
107 to 109	IDIN5 to IDIN7	I	Not used
110	VDIOB1	—	Power supply terminal (+3.3V) (for I/O)
111 to 114	WAD0 to WAD3	I	External A/D data input terminal for PSP physical disc mark detection Not used
115	TESTI	I	Input terminal for disc inspection mode from the I/O expander
116	VSCB2	—	Ground terminal (for core)
117 to 120	WAD4 to WAD7	I	External A/D data input terminal for PSP physical disc mark detection Not used
121	VDCB2	—	Power supply terminal (+2.5V) (for core)

SCD-XA9000ES

Pin No.	Pin Name	I/O	Description
122	WRFD	I	Not used
123	WCK	I	Operation clock signal input for PSP physical disc mark detection from the SACD decoder
124, 125	WAVDD0, WAVDD1	—	A/D power supply terminal (+2.5V) (for PSP physical disc mark detection)
126	WARFI	I	Analog RF signal input for PSP physical disc mark detection from the SACD/CD RF amplifier
127	WAVRB	I	A/D bottom reference terminal for PSP physical disc mark detection
128, 129	WAVSS0, WAVSS1	—	A/D ground terminal (for PSP physical disc mark detection)
130	VSIOA2	—	Ground terminal (for I/O)
131 to 134	DQ7 to DQ4	I/O	Two-way data bus with the D-RAM
135	VDIOA2	—	Power supply terminal (+3.3V) (for I/O)
136 to 139	DQ3 to DQ0	I/O	Two-way data bus with the D-RAM
140	VSIOA3	—	Ground terminal (for I/O)
141	DCLK	O	Clock signal output to the D-RAM
142	DCKE	O	Clock enable signal output to the D-RAM
143	XWE	O	Write enable signal output to the D-RAM
144	XCAS	O	Column address strobe signal output to the D-RAM
145	XRAS	O	Row address strobe signal output to the D-RAM
146	VDIOA3	—	Power supply terminal (+3.3V) (for I/O)
147	NC	O	Not used
148, 149	A11, A10	O	Address signal output to the D-RAM
150	VSCA3	—	Ground terminal (for core)
151, 152	A9, A8	O	Address signal output to the D-RAM
153	VDCA3	—	Power supply terminal (+2.5V) (for core)
154 to 157	A7 to A4	O	Address signal output to the D-RAM
158	VSIOA4	—	Ground terminal (for I/O)
159 to 162	A3 to A0	O	Address signal output to the D-RAM
163	VDIOA4	—	Power supply terminal (+3.3V) (for I/O)
164	XSRQ	O	Serial data request signal output to the SACD decoder
165	XSHD	I	Header flag signal input from the SACD decoder
166	SDCK	I	Serial data transfer clock signal input from the SACD decoder
167	XSAK	I	Serial data effect flag signal input from the SACD decoder
168	SDEF	I	Error flag signal input from the SACD decoder
169 to 176	SD0 to SD7	I	Stream data signal input from the SACD decoder

• MAIN BOARD IC802 CXD9722TQ (DSD DIGITAL SIGNAL PROCESSOR)

Pin No.	Pin Name	I/O	Description
1 to 5	D1 to D5	I/O	Two-way data bus with the SD-RAM
6	VDD	—	Power supply terminal (+3.3V)
7, 8	D6, D7	I/O	Two-way data bus with the SD-RAM
9	VSS	—	Ground terminal
10	WE	O	Write enable signal output to the SD-RAM
11	CAS	O	Column address strobe signal output to the SD-RAM
12	RAS	O	Row address strobe signal output to the SD-RAM
13	CS	O	Chip select signal output to the SD-RAM
14	CLK	O	Clock signal output to the SD-RAM
15	CKE	O	Clock enable signal output to the SD-RAM
16	VDD	—	Power supply terminal (+3.3V)
17 to 22	A11, A10, A0 to A3	O	Address signal output to the SD-RAM
23	VSS	—	Ground terminal
24 to 29	A9 to A4	O	Address signal output to the SD-RAM
30	VSS	—	Ground terminal
31	DRSO	O	Surround R-ch DSD data output to the D/A converter
32	DLSO	O	Surround L-ch DSD data output to the D/A converter
33	DEXRO	O	Not used
34	DLFEO	O	Sub woofer DSD data output to the D/A converter
35	DCO	O	Center DSD data output to the D/A converter
36	VDD	—	Power supply terminal (+3.3V)
37	DRO	O	Front R-ch DSD data output to the D/A converter
38	DLO	O	Front L-ch DSD data output to the D/A converter
39	VSS	—	Ground terminal
40	DMRO	O	DSD data output terminal for R-ch down mix Not used
41	DMLO	O	DSD data output terminal for L-ch down mix Not used
42	VSS	—	Ground terminal
43	VDD	—	Power supply terminal (+3.3V)
44	DLDRO	O	Analog audio data output terminal Not used
45	CSWO	O	Center and sub woofer audio data output terminal Not used
46	SLSRO	O	Surround audio data output terminal Not used
47	FLFRO	O	Front audio data output terminal Not used
48	VSS	—	Ground terminal
49	SPDIFO	O	Digital audio data output terminal Not used
50	TEST1	I	Input terminal for the test
51	TRST	I	Reset signal input from terminal “L”: reset Not used
52	TMS	I	Mode selection signal input terminal Not used
53	TCK	I	Clock signal input terminal Not used
54	TDI	I	Serial data signal input terminal Not used
55	TDO	O	Serial data signal output terminal Not used
56	TEST2	I	Input terminal for the test
57	SPDIFI	I	Digital audio data input terminal Not used
58	VSS	—	Ground terminal
59	LRCKI	I	L/R sampling clock signal (44.1 kHz) input terminal Not used
60	BCKI	I	Bit clock signal (2.8224 MHz) input terminal Not used

SCD-XA9000ES

Pin No.	Pin Name	I/O	Description
61	VDD	—	Power supply terminal (+3.3V)
62	VSS	—	Ground terminal
63	DLDR1	I	Analog audio data input terminal Not used
64	CSWI	I	Center and sub woofer audio data input terminal Not used
65	SLSRI	I	Surround audio data input terminal Not used
66	FLFRI	I	Front audio data input terminal Not used
67	TEST3	I	Input terminal for the test
68	CLK512	I	Master clock signal (22.5792 MHz) input terminal
69	VSS	—	Ground terminal
70	XRST	I	Reset signal input from the CPU “L”: reset
71	VDD	—	Power supply terminal (+3.3V)
72	SCLK	I	Serial clock signal input from the CPU
73	XCS	I	Chip select signal input from the CPU
74	SI	I	Serial data input from the CPU
75	SO	O	Serial data output to the CPU
76	DEXRI	I	Not used
77	DMLI	I	DSD data input terminal for L-ch down mix Not used
78	DMRI	I	DSD data input terminal for R-ch down mix Not used
79	VSS	—	Ground terminal
80	PHAI	I	Clock signal (2.8224 MHz) input terminal
81	BCKAI	I	Clock signal (5.6448 MHz) input terminal
82	DQM	O	Not used
83	DLI	I	Front L-ch DSD data input from DSD decoder
84	DRI	O	Front R-ch DSD data input from DSD decoder
85	DCI	O	Center DSD data input from DSD decoder
86	DLFEI	O	Sub woofer DSD data input from DSD decoder
87	DLSI	O	Surround L-ch DSD data input from DSD decoder
88	DRSI	O	Surround R-ch DSD data input from DSD decoder
89	VSS	—	Ground terminal
90 to 95	D15 to D10	I/O	Two-way data bus with the SD-RAM
96	VDD	—	Power supply terminal (+3.3V)
97, 98	D9, D8	I/O	Two-way data bus with the SD-RAM
99	GND	—	Ground terminal
100	D0	I/O	Two-way data bus with the SD-RAM

• MAIN BOARD IC901 CXP973064-241R (CPU)

Pin No.	Pin Name	I/O	Description
1	MUTE_LOAD	O	Muting on/off control signal output to the loading motor drive “L”: muting on
2	RST_DY	O	Reset signal output to the DSD digital signal processor “L”: reset
3	DOCTRL	O	Digital out on/off control signal output to the digital signal processor “L”: digital out off, “H”: digital out on
4	MUTE_2D	O	Muting on/off control signal output to the focus/tracking coil drive “L”: muting on
5	MODE_SACD	O	SACD/CD mode selection signal output terminal “L”: CD mode, “H”: SACD mode
6	SP_ON	O	Muting on/off control signal output to the spindle motor drive “L”: muting on
7	FCS_JMP1	O	Focus jump 1 signal output terminal
8	FCS_JMP2	O	Focus jump 2 signal output terminal
9	SENS_CD	I	Internal status (SENSE) signal input from the digital signal processor
10	XDIS_IO	O	Reset signal output to the I/O expander “L”: reset
11	XCS_IO	O	Chip select signal output to the I/O expander
12	XCS_DVD	O	Chip select signal output to the SACD decoder
13	VSS	—	Ground terminal (digital system)
14 to 21	D0 to D7	I/O	Two-way data bus with the SACD decoder and I/O expander
22	INT0_DVD	I	Interrupt signal input from the SACD decoder
23	INT1_DVD	I	Interrupt signal input from the SACD decoder
24	T_SENS	I	Input terminal of disc tray status detection signal from table sensor Not used
25	MIRR_RF	I	Mirror signal input from the digital signal processor
26	SCOR_CD	I	Subcode sync (S0+S1) detection signal input from the digital signal processor
27	RDY_DSD	I	Ready signal input from the DSD decoder “L”: ready
28	MUTE_DSD	O	Soft muting on/off control signal output to the DSD decoder “H”: muting on
29	COUT_CD	I	Numbers of track counted signal input from the digital signal processor
30	IN_SW	I	Loading in switch input terminal “L”: loading in
31	OUT_SW	I	Loading out switch input terminal “L”: loading out
32	—	I	Not used
33	SQSO_CD	I	Subcode Q data input from the digital signal processor
34	DATA_CD	O	Serial data output to the digital signal processor
35	CLOK_CD	O	Serial data transfer clock signal output to the digital signal processor
36	XLAT_CD	O	Serial data latch pulse signal output to the digital signal processor
37	SQCK_CD	O	Subcode Q data reading clock signal output to the digital signal processor
38	XRST	I	System reset signal input terminal “L”: reset For several hundreds msec. after the power supply rises, “L” is input, then it changes to “H”
39	VSS	—	Ground terminal (digital system)
40	XTAL	I	System clock input terminal (20 MHz)
41	EXTAL	O	System clock output terminal (20 MHz)
42	VDD	—	Power supply terminal (+3.3V) (digital system)
43	SPDA	O	Spindle motor control signal output terminal
44	APDO	O	Output terminal for offset adjustment of APEO (Ⓔ pin of SACD decoder)
45	LOAD_IN	O	Loading motor drive signal (loading in direction) output terminal
46	LOAD_OUT	O	Loading motor drive signal (loading out direction) output terminal
47	XLAT_DSD	O	Serial data latch pulse signal output to the DSD decoder
48	SIN_DSD	I	Serial data input from the DSD decoder and DSD digital signal processor
49	SOUT_DSD	O	Serial data output to the DSD decoder, DSD digital signal processor and D/A converter
50	SCK_DSD	O	Serial data transfer clock signal output to the DSD decoder, DSD digital signal processor and D/A converter

Pin No.	Pin Name	I/O	Description
51	BUSY_DP	I	Busy signal input from the display controller
52	SIN_DP	I	Serial data input from the display controller
53	SOUT_DP	O	Serial data output to the display controller
54	SCLK_DP	O	Serial data transfer clock signal output to the display controller
55	VSS	—	Ground terminal (digital system)
56	REQ_DP	O	Request signal output to the display controller
57	XCS_DY	O	Chip select signal output to the DSD digital signal processor
58	GFS_DVD	I	Guard frame sync signal input from the SACD decoder
59	SP_ERR	I	Spindle motor backward voltage input terminal
60	AMUT_MCH	O	Surround, center and sub woofer audio muting on/off control signal output terminal “L”: muting on
61	MLS_RST	O	Reset signal output to the i-link system controller “L”: reset
62	LAT_DF_B	O	Serial data latch pulse signal output to the D/A converter
63	DOON	O	Digital out on/off control signal output terminal “L”: digital out off, “H”: digital out on
64	JITTER	I	Jitter signal input terminal
65	TE	I	Tracking error signal input from the SACD/CD RF amplifier
66	PI	I	Pull in signal input from the SACD/CD RF amplifier
67	FE	I	Focus error signal input from the SACD/CD RF amplifier
68	AVSS	—	Ground terminal (for A/D converter)
69	AVREF	I	Reference voltage (+3.3V) input terminal (for A/D converter)
70	AVDD	—	Power supply terminal (+3.3V) (for A/D converter)
71	GFS_CD	I	Guard frame sync signal input from the digital signal processor
72	SCLK_CD	O	SENSE serial data reading clock signal output to the digital signal processor
73	MUTE_CD	O	Muting on/off control signal output to the digital signal processor “H”: muting on
74	FOK_CD	I	Focus OK signal input from the digital signal processor
75	LOCK_CD	I	GFS is sampled by 460 Hz “H” input when GFS is “H”
76	MULTI	O	Multi/2ch selection signal output terminal “L”: 2ch, “H”: multi
77	CLK_RF	O	Serial data transfer clock signal output to the SACD/CD RF amplifier
78	EEPSIO	I/O	Two-way data bus with the EEPROM and i-link system controller
79	EEPSCL	I/O	Clock signal bus with the EEPROM and i-link system controller
80	RXD	I	Not used
81	TXD	O	Not used
82	CLK_SW	I	OSC on/off control signal output terminal “L”: OSC off, “H”: OSC on
83	DATA_RF	I/O	Two-way data bus with the SACD/CD RF amplifier
84	XWR	O	Write strobe signal output to the SACD decoder and I/O expander
85	XRD	O	Read strobe signal output to the SACD decoder and I/O expander
86	NC_(PWE/VPP)	—	Not used
87	VDD	—	Power supply terminal (+3.3V) (digital system)
88	VSS	—	Ground terminal (digital system)
89	A0	O	Address signal output to the SACD decoder and I/O expander
90 to 96	A1 to A7	O	Address signal output to the SACD decoder
97	INIT_DF	O	Reset signal output to the D/A converter “L”: reset
98	LAT_DF_A	O	Serial data latch pulse signal output to the D/A converter
99	SWGUP	O	Sub woofer gain up/normal control signal output terminal “L”: normal, “H”: gain up
100	LD_ON	O	Laser diode on/off control signal output to the SACD/CD RF amplifier “L”: laser diode off, “H”: laser diode on

• MAIN BOARD IC904 ISPLSI2032VE-110LT44-SA8 (I/O EXPANDER)

Pin No.	Pin Name	I/O	Description
1	SI_SEL	O	Serial data selection signal output for SIN_DSD (Ⓓ pin of CPU) “L”: DSD decoder serial data, “H”: DSD digital signal processor serial data
2	ZEROL	I	L-ch zero data flag detection signal input terminal Not used
3	FS64	O	Clock signal (2.8224 MHz) output terminal Not used
4	FS128	O	Clock signal (5.6448 MHz) output terminal Not used
5	YO	I	Clock signal (11.2896 MHz) input terminal Not used
6	VCC	—	Power supply terminal (+5V) (digital system)
7	XBSCAN	—	Not used
8	TDI	—	Not used
9	XCS	I	Chip select signal input from the CPU
10	XRD	I	Read strobe signal input from the CPU
11	XWR	I	Write strobe signal input from the CPU
12 to 16	D0 to D4	I/O	Two-way data bus with the SACD decoder and the CPU
17	GND	—	Ground terminal (digital system)
18	TDO	—	Not used
19 to 21	D5 to D7	I/O	Two-way data bus with the SACD decoder and the CPU
22	A	I	Address signal input from the CPU
23	CDPDSW	O	Photo diode for CD on/off control signal output terminal Not used
24	RST	I	Reset signal input from the CPU “L”: reset
25	RST_DSD	O	Reset signal output to the DSD decoder “L”: reset
26	RST_DP	O	Reset signal output to the display controller “L”: reset
27	TCK	—	Not used
28	VCC	—	Power supply terminal (+5V) (digital system)
29	XRESET	—	Not used
30	TMS	—	Not used
31	RST_DVD	O	Reset signal output to the SACD decoder “L”: reset
32	RST_CD	O	Reset signal output to the digital signal processor “L”: reset
33	VMOD	O	Photo diode on/off control signal output terminal “H”: photo diode on
34	MULTI	O	Multi/2ch selection signal output terminal Not used
35	SDEN	O	Serial data enable signal output to SACD/CD RF amplifier
36	ISBTEST	O	Output terminal for disc inspection mode to DSD decoder
37	AMUTE	O	Front and 2ch audio muting on/off control signal output terminal “L”: muting on
38	LMUTE	O	L-ch muting on/off control signal output terminal Not used
39	GND	—	Ground terminal (digital system)
40	GOE	—	Not used
41	ZEROR	I	R-ch zero data flag detection signal input terminal Not used
42	ZDFL	I	Front L-ch zero data flag detection signal input terminal Not used
43	ZDFR	I	Front R-ch zero data flag detection signal input terminal Not used
44	LIM_SW	I	Detection signal input from limit in switch The optical pick-up is inner position when “H”

• LINK BOARD IC1902 TMS320VC5409PGE100A (I-LINK DSP)

Pin No.	Pin Name	I/O	Description
1	VSS	—	Ground terminal
2	A22	O	Address signal output terminal Not used
3	VSS	—	Ground terminal
4	DVDD (3.3V)	—	Power supply terminal (+3.3V)
5	A10	O	Address signal output terminal Not used
6	HD7	I/O	Two-way data bus with the i-link system controller
7 to 11	A11 to A15	O	Address signal output terminal Not used
12	CVDD (1.8V)	—	Power supply terminal (+1.8V)
13	$\overline{\text{HAS}}$	I	Address strobe signal input from the i-link system controller
14, 15	VSS	—	Ground terminal
16	CVDD (1.8V)	—	Power supply terminal (+1.8V)
17	$\overline{\text{HCS}}$	I	Chip select signal input from the i-link system controller
18	$\overline{\text{HR}}/\overline{\text{W}}$	I	Read/write signal input from the i-link system controller
19	READY	I	Ready signal input terminal Not used
20	$\overline{\text{PS}}$	I	Program select signal input terminal Not used
21	$\overline{\text{DS}}$	I	Data select signal input terminal Not used
22	$\overline{\text{IS}}$	I	I/O space select signal input terminal Not used
23	$\overline{\text{R}}/\overline{\text{W}}$	O	Read/write signal output terminal Not used
24	$\overline{\text{MSTRB}}$	O	Memory strobe signal output terminal Not used
25	$\overline{\text{IOSTRB}}$	O	I/O strobe signal output terminal Not used
26	$\overline{\text{MSC}}$	O	Microstate complete signal output terminal Not used
27	XF	O	External flag signal output to the i-link system controller
28	$\overline{\text{HOLDA}}$	O	Hold acknowledge signal output terminal Not used
29	$\overline{\text{IAQ}}$	O	Instruction acquisition signal output terminal Not used
30	$\overline{\text{HOLD}}$	I	Hold signal input terminal Not used
31	$\overline{\text{BIO}}$	I	Branch control signal input terminal Not used
32	$\overline{\text{MP}}/\overline{\text{MC}}$	I	Microprocessor/microcomputer mode selection signal input terminal “L”: microcomputer mode, “H”: microprocessor mode Fixed at “L” in this set
33	DVDD (3.3V)	—	Power supply terminal (+3.3V)
34	VSS	—	Ground terminal
35	BDR1	I	Serial data input terminal Not used
36	BFSR1	I	Frame sync signal input terminal Not used
37	VSS	—	Ground terminal
38	BCLKR1	I	Receive clock signal input terminal Not used
39	HCNTL2	I	Control signal input from the i-link system controller
40	VSS	—	Ground terminal
41, 42	BCLKR0, BCLKR2	I	Receive clock signal input terminal Not used
43, 44	BFSR0, BFSR2	I	Frame sync signal input terminal Not used
45	BDR0	I	Serial data input terminal Not used
46	HCNTL1	I	Control signal input from the i-link system controller
47	BDR2	I	Serial data input terminal Not used
48, 49	BCLKX0, BCLKX2	I	Transmit clock signal input terminal Not used
50	VSS	—	Ground terminal
51	$\overline{\text{HINT}}$	O	Interrupt signal output to the $\overline{\text{INT2}}$ (Ⓢ pin)
52	CVDD (1.8V)	—	Power supply terminal (+1.8V)
53, 54	BFSX0, BFSX2	I	Frame sync signal input terminal Not used

Pin No.	Pin Name	I/O	Description
55	HRDY	O	Ready signal output to the i-link system controller
56	DVDD (3.3V)	—	Power supply terminal (+3.3V)
57	VSS	—	Ground terminal
58	HD0	I/O	Two-way data bus with the i-link system controller
59, 60	BDX0, BDX2	O	Serial data output terminal Not used
61	IACK	O	Interrupt acknowledge signal output terminal Not used
62	HBIL	I	Byte identification signal input from the i-link system controller
63	$\overline{\text{NMI}}$	I	Non-maskable interrupt input terminal Not used
64, 65	$\overline{\text{INT0}}$, $\overline{\text{INT1}}$	I	Interrupt signal input terminal Not used
66	$\overline{\text{INT2}}$	I	Interrupt signal input from the $\overline{\text{HINT}}$ (Ⓢ) pin)
67	$\overline{\text{INT3}}$	I	Interrupt signal input terminal Not used
68	CVDD (1.8V)	—	Power supply terminal (+1.8V)
69	HD1	I/O	Two-way data bus with the i-link system controller
70	VSS	—	Ground terminal
71	BCLKX1	I	Transmit clock signal input terminal Not used
72	VSS	—	Ground terminal
73	BFSX1	I	Frame sync signal input terminal Not used
74	BDX1	O	Serial data output terminal Not used
75	DVDD (3.3V)	—	Power supply terminal (+3.3V)
76	VSS	—	Ground terminal
77 to 79	CLKMD1 to CLKMD3	I	Clock mode selection signal input terminal Not used
80	HPI16	I	HPI 16 bit selection signal input terminal Not used
81	HD1	I/O	Two-way data bus with the i-link system controller
82	TOUT	O	Timer output terminal Not used
83	EMU0	I	Not used
84	EMU1/ $\overline{\text{OFF}}$	I	Not used
85	TDO	O	Not used
86	TDI	I	Not used
87	$\overline{\text{TRST}}$	I	Not used
88	TCK	I	Not used
89	TMS	I	Not used
90	VSS	—	Ground terminal
91	CVDD (1.8V)	—	Power supply terminal (+1.8V)
92	HPIENA	I	HPI module selection signal input terminal Not used
93	VSS	—	Ground terminal
94	CLKOUT	O	Master clock signal output terminal Not used
95	HD3	I/O	Two-way data bus with the i-link system controller
96	X1	O	System clock output terminal (20 MHz)
97	X2/CLKIN	I	System clock input terminal (20 MHz)
98	$\overline{\text{RS}}$	I	Reset signal input from the i-link system controller “L”: reset
99 to 104	D0 to D5	I/O	Two-way data bus terminal Not used
105	A16	O	Address signal output terminal Not used
106	VSS	—	Ground terminal
107 to 110	A17 to A20	O	Address signal output terminal Not used
111	VSS	—	Ground terminal
112	DVDD (3.3V)	—	Power supply terminal (+3.3V)

SCD-XA9000ES

Pin No.	Pin Name	I/O	Description
113 to 119	D6 to D12	I/O	Two-way data bus terminal Not used
120	HD4	I/O	Two-way data bus with the i-link system controller
121 to 123	D13 to D15	I/O	Two-way data bus terminal Not used
124	HD5	I/O	Two-way data bus with the i-link system controller
125	CVDD (1.8V)	—	Power supply terminal (+1.8V)
126	VSS	—	Ground terminal
127	$\overline{\text{HDS1}}$	I	Data strobe signal input from the i-link system controller
128	VSS	—	Ground terminal
129	$\overline{\text{HDS2}}$	I	Data strobe signal input from the i-link system controller
130	DVDD (3.3V)	—	Power supply terminal (+3.3V)
131 to 134	A0 to A3	O	Address signal output terminal Not used
135	HD6	I/O	Two-way data bus with the i-link system controller
136 to 141	A4 to A9	O	Address signal output terminal Not used
142	CVDD (1.8V)	—	Power supply terminal (+1.8V)
143	A21	O	Address signal output terminal Not used
144	VSS	—	Ground terminal

• LINK BOARD IC1903 M30626FHPFP-SCD-XA9000 (I-LINK SYSTEM CONTROLLER)

Pin No.	Pin Name	I/O	Description
1 to 7	HD6 to HD0	I/O	Two-way data bus with the i-link DSP
8	BYTE	I	External data bus line byte selection signal input terminal “L”: 16 bit, “H”: 8 bit Fixed at “L” in this set
9	CNVSS	—	Processor mode selection signal input terminal “L”: single Fixed at “L” in this set
10, 11	NC	O	Not used
12	RESET	I	Reset signal input from the CPU “L”: reset
13	XOUT	O	System clock output terminal (10 MHz)
14	VSS	—	Ground terminal
15	XIN	I	System clock input terminal (10 MHz)
16	VCC	—	Power supply terminal (+3.3V)
17	NMI	I	Non-maskable interrupt input terminal Not used
18	NC	O	Not used
19	AKE_XF	I	External flag signal input from the i-link DSP
20	NC	O	Not used
21	HRDY	I	Ready signal input from the i-link DSP
22	XHAS	O	Address strobe signal output to the i-link DSP
23, 24	XHDS1, XHDS2	O	Data strobe signal output to the i-link DSP
25	XHCS	O	Chip select signal output to the i-link DSP
26	XRS	O	Reset signal output to the i-link DSP “L”: reset
27, 28	NC	O	Not used
29	IIC CLK	I/O	Clock signal bus with the CPU and EEPROM
30	IIC DATA	I/O	Two-way data bus with the CPU and EEPROM
31	TXD1	I	Not used
32	RXD1	I	Not used
33	CLK1	I	Not used
34	RTS1	I	Not used
35 to 38	NC	O	Not used
39	RDY	I	Ready signal input from the i-link interface
40	ALE	O	Not used
41	HOLD	I	Not used
42	HLDA	O	Not used
43	BCLK	O	Not used
44	RD	O	Read data output to the i-link interface and EEPROM
45	WRH	O	Not used
46	WR	O	Write data output to the i-link interface and EEPROM
47	NC	O	Not used
48	EEP_CS	O	Chip select signal output to the EEPROM
49	CS1	O	Chip select signal output to the i-link interface
50	NC	O	Not used
51, 52	HCNTL0, HCNTL1	O	Control signal output to the i-link DSP
53	HBIL	O	Byte identification signal output to the i-link DSP
54	HRW	O	Read/write signal output to the i-link DSP
55, 56	NC	O	Not used
57 to 61	A13 to A9	O	Address signal output to the EEPROM
62	VCC	—	Power supply terminal (+3.3V)
63	A8	O	Address signal output to the i-link interface and EEPROM

SCD-XA9000ES

Pin No.	Pin Name	I/O	Description
64	GND	—	Ground terminal
65 to 71	A7 to A1	O	Address signal output to the i-link interface and EEPROM
72	A0	O	Address signal output terminal Not used
73 to 88	D15 to D0	I/O	Two-way data bus with the i-link interface and EEPROM
89	PHY_BIAS	O	Power down signal output to the i-link interface
90	PHY_RST	O	Power reset signal output to the i-link interface “L”: reset
91	NC	O	Not used
92	LINK_RST	O	Link reset signal output to the i-link interface “L”: reset
93 to 95	NC	O	Not used
96	AVSS	—	Ground terminal (for A/D converter)
97	NC	O	Not used
98	A/D VREF	I	Reference voltage (+3.3V) input terminal (for A/D converter)
99	AVCC 3.3V	—	Power supply terminal (+3.3V) (for A/D converter)
100	HD7	I/O	Two-way data bus with the i-link DSP

• DISPLAY BOARD IC803 CXP84120-092Q (DISPLAY CONTROLLER)

Pin No.	Pin Name	I/O	Description
1 to 29	NC	O	Not used
30	$\overline{\text{RESET}}$	I	Reset signal input from the I/O expander “L”: reset
31	EXTAL	O	System clock output terminal (8 MHz)
32	XTAL	I	System clock input terminal (8 MHz)
33	VSS	—	Ground terminal (digital system)
34, 35	NC	O	Not used
36	AVSS	—	Ground terminal (for A/D converter)
37	AVREF	I	Reference voltage (+5V) input terminal (for A/D converter)
38 to 41	NC	O	Not used
42	TEST	I	Test mode setting terminal “L”: test mode, normally: fixed at “H”
43	NC	O	Not used
44, 45	KEY0, KEY1	I	Front key input terminal (A/D input)
46	RESET-OUT	O	Reset signal output to the FL driver “L”: reset
47	$\overline{\text{ACK}}$	O	Busy signal output to the CPU
48	SCK	I	Serial data transfer clock signal input from the CPU
49	SIN	I	Serial data input from the CPU
50	SOUT	O	Serial data output to the CPU
51	$\overline{\text{CP}}$	O	Serial data transfer clock signal output to the FL driver
52	$\overline{\text{CS}}$	O	Chip select signal output to the FL driver
53	DA	O	Serial data output to the FL driver
54, 55	(+5V)	—	Power supply terminal (+5V)
56	SIRCS	I	SIRCS signal input from the remote control receiver
57	(+5V)	—	Power supply terminal (+5V)
58, 59	NC	O	Not used
60	$\overline{\text{REQ}}$	I	Request signal input from the CPU
61 to 64	NC	O	Not used
65	LED (I-LINK)	O	LED drive signal output of the i.LINK indicator “L”: LED on
66	LED (PLAY)	O	LED drive signal output of the ► indicator “L”: LED on
67	LED (PAUSE)	O	LED drive signal output of the ■■ indicator “L”: LED on
68	JOG B	I	Jog dial pulse input from the rotary encoder (B phase input)
69	JOG A	I	Jog dial pulse input from the rotary encoder (A phase input)
70, 71	NC	O	Not used
72	VDD	—	Power supply terminal (+5V)
73	(+5V)	—	Power supply terminal (+5V)
74 to 76	DUTY0 to DUTY2	I	Not used
77 to 80	NC	O	Not used

SECTION 6 EXPLODED VIEWS

NOTE:

- XX and -X mean standardized parts, so they may have some difference from the original one.
 - Color Indication of Appearance Parts
Example:
KNOB, BALANCE (WHITE) . . . (RED)
- ↑ ↑
Parts Color Cabinet's Color

- Items marked "*" are not stocked since they are seldom required for routine service. Some delay should be anticipated when ordering these items.
- Accessories are given in the last of the electrical parts list.
- Color variation
SILVER : US, Canadian, AEP model
GOLD : AEP, Taiwan model
BLACK : AEP model

The components identified by mark Δ or dotted line with mark Δ are critical for safety. Replace only with part number specified.

Les composants identifiés par une marque Δ sont critiques pour la sécurité. Ne les remplacer que par une pièce portant le numéro spécifié.

6-1. CASE SECTION

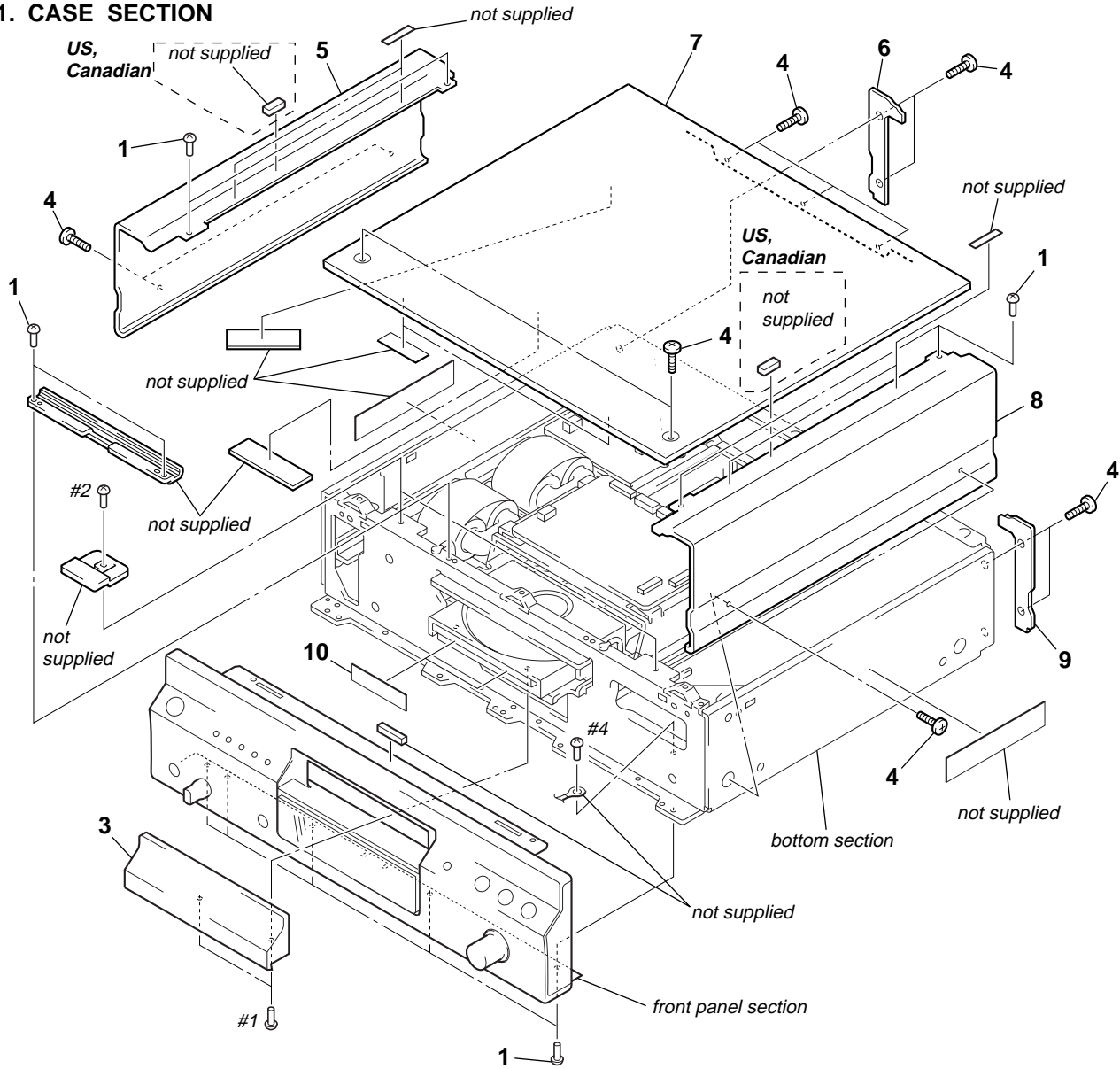

Ref. No.	Part No.	Description	Remark	Ref. No.	Part No.	Description	Remark
1	4-929-074-01	SCREW (3X8)		7	4-235-616-21	CASE (TOP) (SILVER)	
3	A-4739-675-A	PANEL ASSY, LOADING (BLACK)		7	4-235-616-31	CASE (TOP) (GOLD)	
3	A-4739-704-A	PANEL ASSY, LOADING (GOLD)		8	4-235-618-01	PLATE (RIGHT), SIDE (GOLD)	
3	A-4739-776-A	PANEL ASSY, LOADING (SILVER)		8	4-235-618-11	PLATE (RIGHT), SIDE (BLACK)	
4	4-227-843-03	SCREW (TP), FLAT HEAD (for BLACK)		8	4-235-618-21	PLATE (RIGHT), SIDE (SILVER)	
4	4-227-843-31	SCREW (TP), FLAT HEAD (for SILVER, GOLD)		9	4-235-636-01	PLATE (SIDE-R), ORNAMENTAL (GOLD)	
5	4-235-617-01	PLATE (LEFT), SIDE (GOLD)		9	4-235-636-11	PLATE (SIDE-R), ORNAMENTAL (BLACK)	
5	4-235-617-11	PLATE (LEFT), SIDE (BLACK)		9	4-235-636-21	PLATE (SIDE-R), ORNAMENTAL (SILVER)	
5	4-235-617-21	PLATE (LEFT), SIDE (SILVER)		*	10	4-615-354-01	SPACER
6	4-235-635-01	PLATE (SIDE-L), ORNAMENTAL (GOLD)		#1	7-685-147-21	SCREW +P 3X10, TYPE2 SLIT	
6	4-235-635-11	PLATE (SIDE-L), ORNAMENTAL (BLACK)		#2	7-682-548-09	SCREW +B 3X8	
6	4-235-635-21	PLATE (SIDE-L), ORNAMENTAL (SILVER)		#4	7-685-871-01	SCREW +BVTT 3X6 (S)	
7	4-235-616-11	CASE (TOP) (BLACK)					

6-2. FRONT PANEL SECTION-1

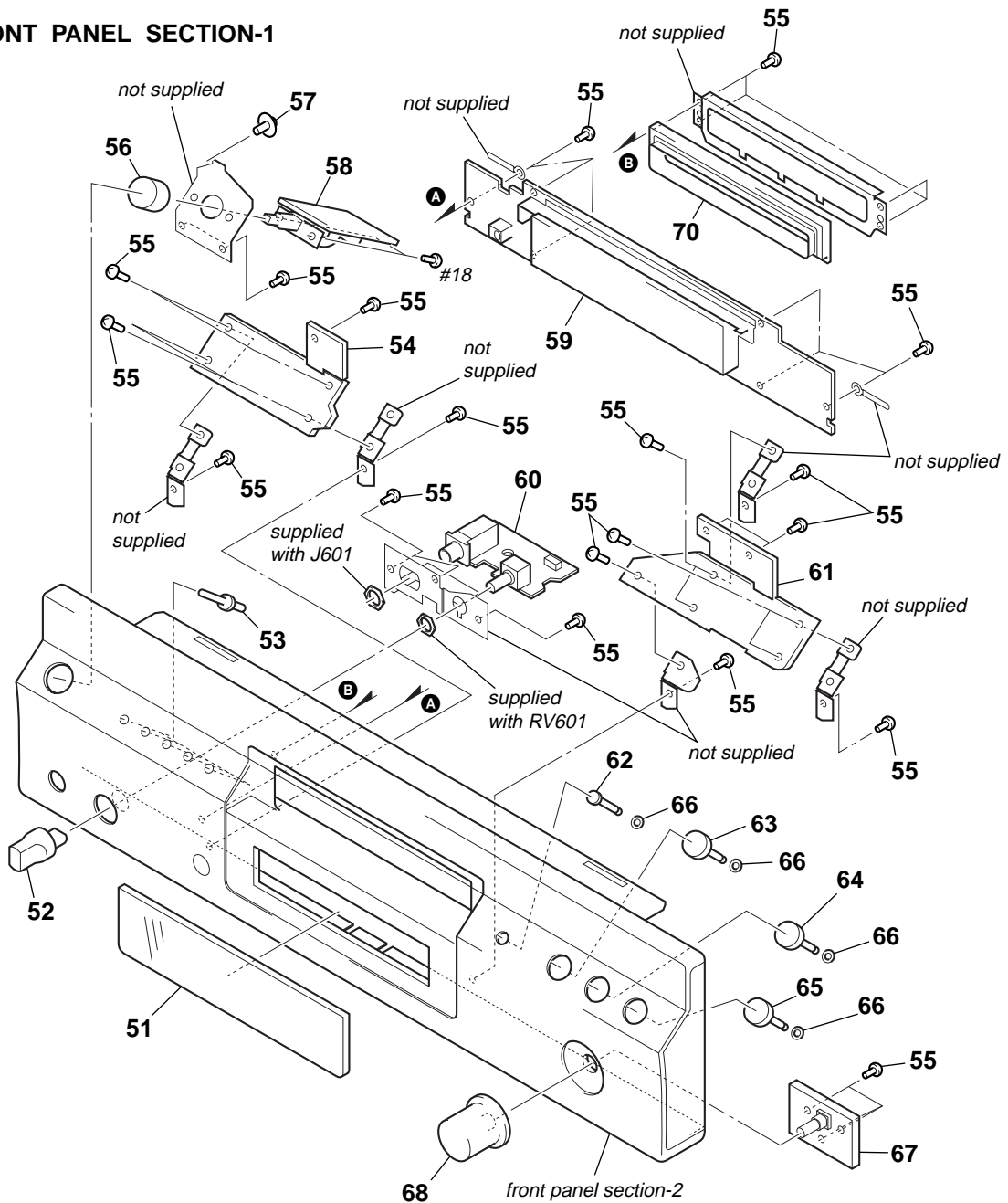

Ref. No.	Part No.	Description	Remark	Ref. No.	Part No.	Description	Remark
51	4-246-566-02	WINDOW (for BLACK)		62	4-246-568-11	BUTTON (OPEN) (≡) (GOLD)	
51	4-246-566-12	WINDOW (for SILVER, GOLD)		62	4-246-568-21	BUTTON (OPEN) (≡) (SILVER)	
52	4-250-532-01	KNOB (HP-VOL) (BLACK)		63	4-246-567-01	BUTTON (PLAY) (▶) (BLACK)	
52	4-250-532-11	KNOB (HP-VOL) (GOLD)		63	4-246-567-11	BUTTON (PLAY) (▶) (GOLD)	
52	4-250-532-21	KNOB (HP-VOL) (SILVER)		63	4-246-567-21	BUTTON (PLAY) (▶) (SILVER)	
53	4-230-635-11	BUTTON (PLAY MODE) (BLACK)		64	4-246-567-31	BUTTON (PLAY) (▨) (BLACK)	
53	4-230-635-21	BUTTON (PLAY MODE) (GOLD)		64	4-246-567-41	BUTTON (PLAY) (▨) (GOLD)	
53	4-230-635-31	BUTTON (PLAY MODE) (SILVER)		64	4-246-567-51	BUTTON (PLAY) (▨) (SILVER)	
54	1-689-069-11	KEY-B BOARD		65	4-246-567-61	BUTTON (PLAY) (■) (BLACK)	
55	3-087-053-01	+BVTP 2.6 (3CR)		65	4-246-567-71	BUTTON (PLAY) (■) (GOLD)	
56	X-4955-616-1	BUTTON (POWER) ASSY (BLACK)		65	4-246-567-81	BUTTON (PLAY) (■) (SILVER)	
56	X-4955-617-1	BUTTON (POWER) ASSY (GOLD)		66	3-325-697-01	WASHER	
56	X-4955-618-1	BUTTON (POWER) ASSY (SILVER)		67	1-689-070-11	JOG BOARD	
57	4-985-672-01	SCREW (+PTPWH M2.6), FLOATING		68	X-4955-651-1	KNOB (SEL) ASSY (SILVER)	
58	1-689-071-11	AC SW BOARD		68	X-4955-655-1	KNOB (SEL) ASSY (GOLD)	
59	A-4747-500-A	DISPLAY BOARD, COMPLETE		68	X-4955-656-1	KNOB (SEL) ASSY (BLACK)	
60	1-689-072-11	HP BOARD		70	4-235-619-01	PACKING (LOADING)	
61	1-689-068-11	KEY-A BOARD		#18	7-685-646-79	SCREW +BVTP 3X8 TYPE2 IT-3	
62	4-246-568-01	BUTTON (OPEN) (≡) (BLACK)					

6-3. FRONT PANEL SECTION-2

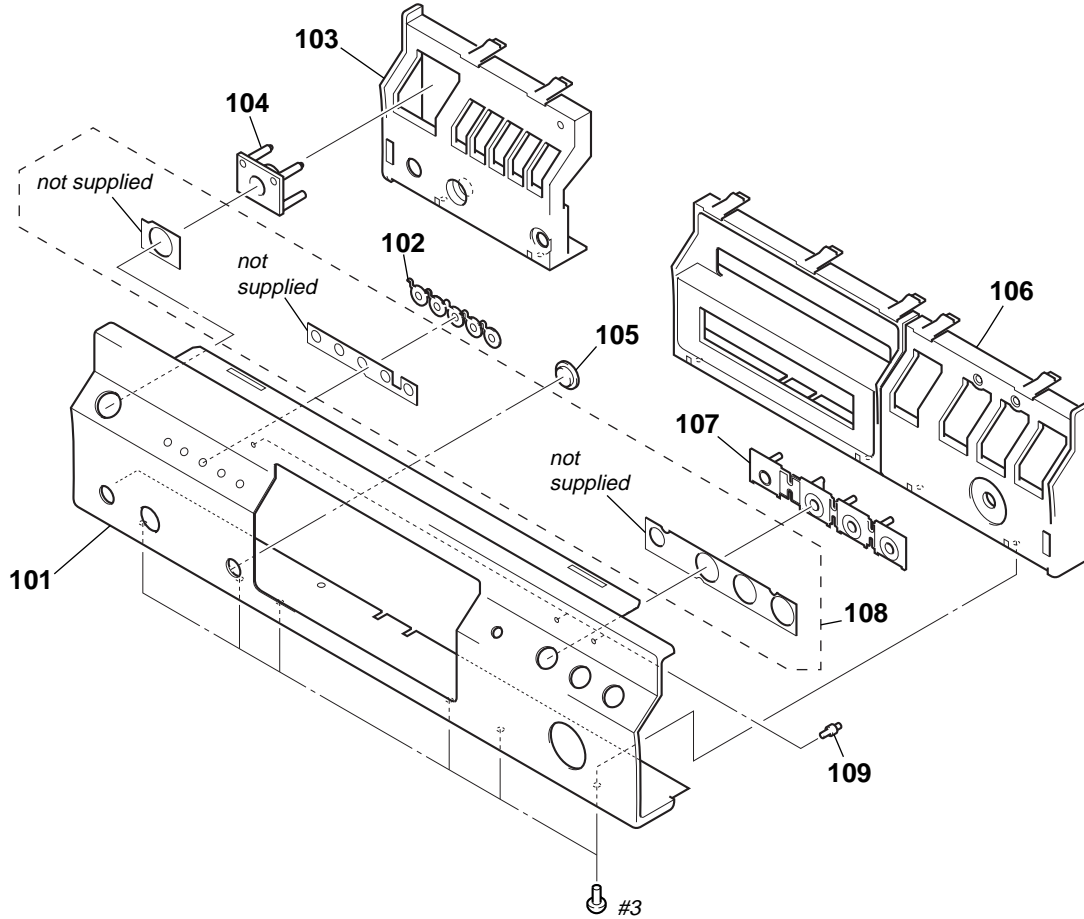

Ref. No.	Part No.	Description	Remark	Ref. No.	Part No.	Description	Remark
101	4-246-560-22	PANEL, FRONT (BLACK)		105	4-975-105-01	WINDOW, RAY CATCHER (BLACK)	
101	4-246-560-32	PANEL, FRONT (GOLD)		105	4-975-105-32	WINDOW, RAY CATCHER (GOLD)	
101	4-246-560-42	PANEL, FRONT (SILVER) (US, Canadian)		105	4-975-105-41	WINDOW, RAY CATCHER (SILVER)	
101	4-246-560-52	PANEL, FRONT (SILVER) (AEP)		106	4-246-561-01	BASE (R), PANEL (BLACK)	
102	4-246-564-01	ESCUTCHEON (B) (BLACK)		106	4-246-561-11	BASE (R), PANEL (GOLD)	
102	4-246-564-11	ESCUTCHEON (B) (GOLD)					
102	4-246-564-21	ESCUTCHEON (B) (SILVER)		106	4-246-561-21	BASE (R), PANEL (SILVER)	
103	4-246-562-01	BASE (L), PANEL (BLACK)		107	4-246-563-01	ESCUTCHEON (A) (BLACK)	
103	4-246-562-12	BASE (L), PANEL (GOLD)		107	4-246-563-11	ESCUTCHEON (A) (GOLD)	
103	4-246-562-22	BASE (L), PANEL (SILVER)		107	4-246-563-21	ESCUTCHEON (A) (SILVER)	
104	4-246-565-01	ESCUTCHEON (C) (BLACK)		108	4-250-643-01	SHEET (ES-A), ADHESIVE	
104	4-246-565-11	ESCUTCHEON (C) (GOLD)		109	X-4950-462-1	LENS ASSY, LED	
104	4-246-565-21	ESCUTCHEON (C) (SILVER)		#3	7-685-548-19	SCREW +BTP 3X12 TYPE2 N-S	

6-4. BOTTOM SECTION

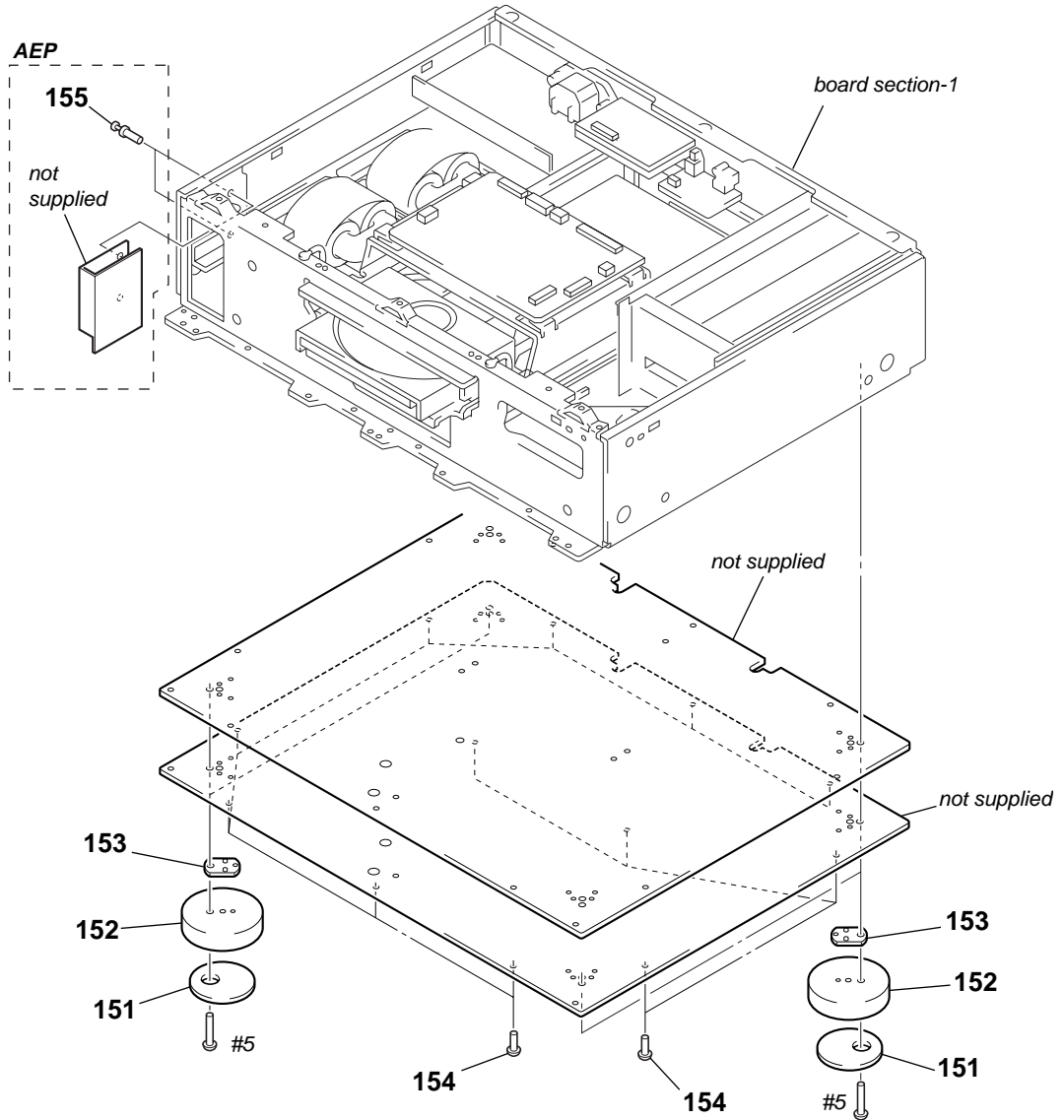

Ref. No.	Part No.	Description	Remark	Ref. No.	Part No.	Description	Remark
151	4-970-124-12	CUSHION (F50180S)		154	4-929-074-01	SCREW (3X8)	
152	4-970-487-01	FOOT (F50180S)		155	3-531-576-01	RIVET (AEP)	
153	4-970-488-01	SPACER (F50180S)		#5	7-685-886-09	SCREW +BVTT 4X20 (S)	

6-5. BOARD SECTION-1

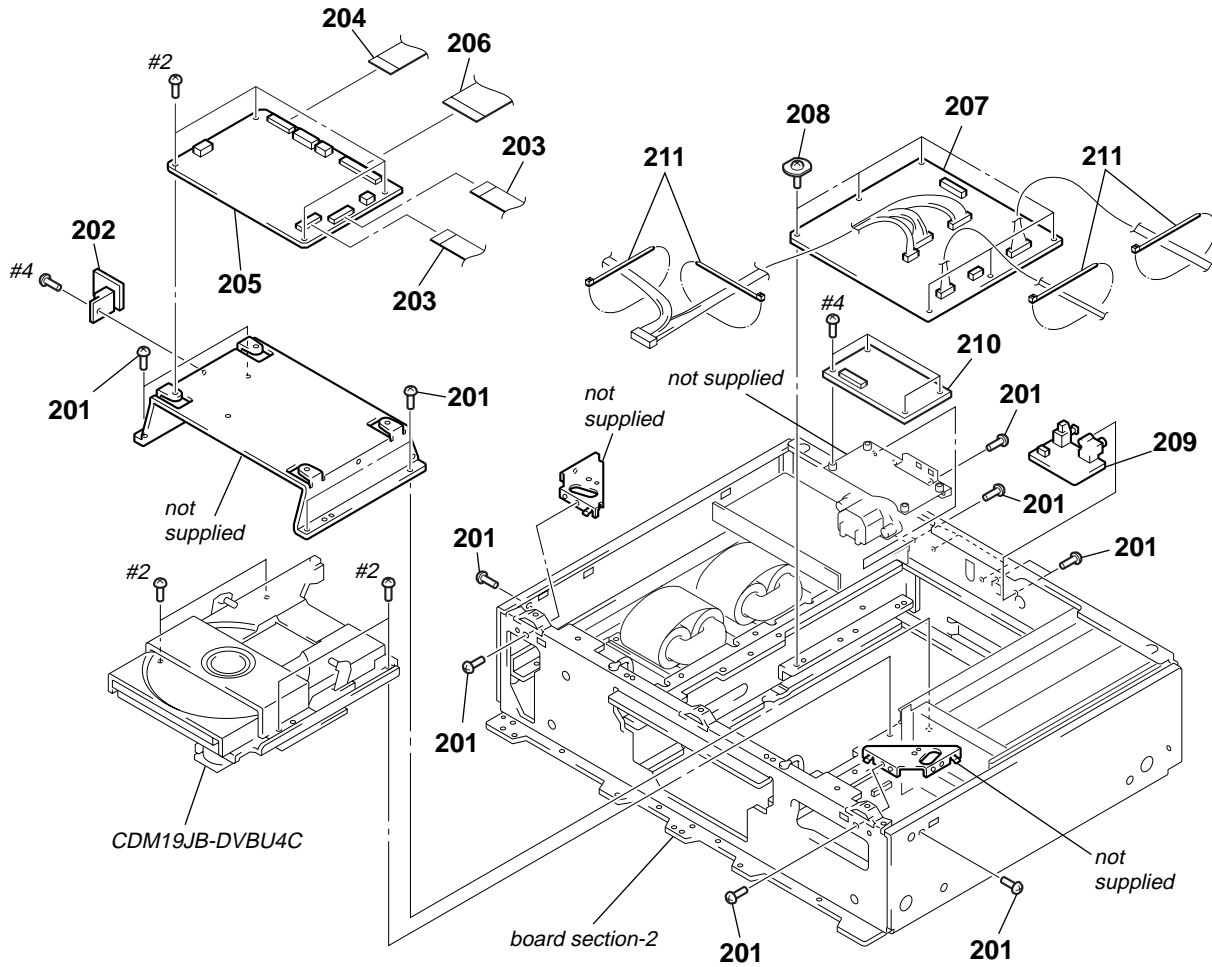

Ref. No.	Part No.	Description	Remark	Ref. No.	Part No.	Description	Remark
201	4-929-074-01	SCREW (3X8)		207	A-4747-600-A	A-POWER BOARD, COMPLETE (EXCEPT AEP)	
202	1-860-271-21	IC BOARD		208	X-4954-269-1	SCREW ASSY, + BVTT	
203	1-775-172-11	WIRE (FLAT TYPE) (19 CORE)		209	A-4747-509-A	D-OUT BOARD, COMPLETE	
204	1-775-225-11	WIRE (FLAT TYPE) (25 CORE)		210	A-1143-923-A	LINK BOARD, COMPLETE (for SERVICE)	
205	A-4747-512-A	MAIN BOARD, COMPLETE		211	3-655-653-01	BAND (TAITON), BINDING	
206	1-757-098-11	WIRE (FLAT TYPE) (35 CORE)		#2	7-682-548-09	SCREW +B 3X8	
207	A-4747-511-A	A-POWER BOARD, COMPLETE (AEP)		#4	7-685-871-01	SCREW +BVTT 3X6 (S)	

6-6. BOARD SECTION-2

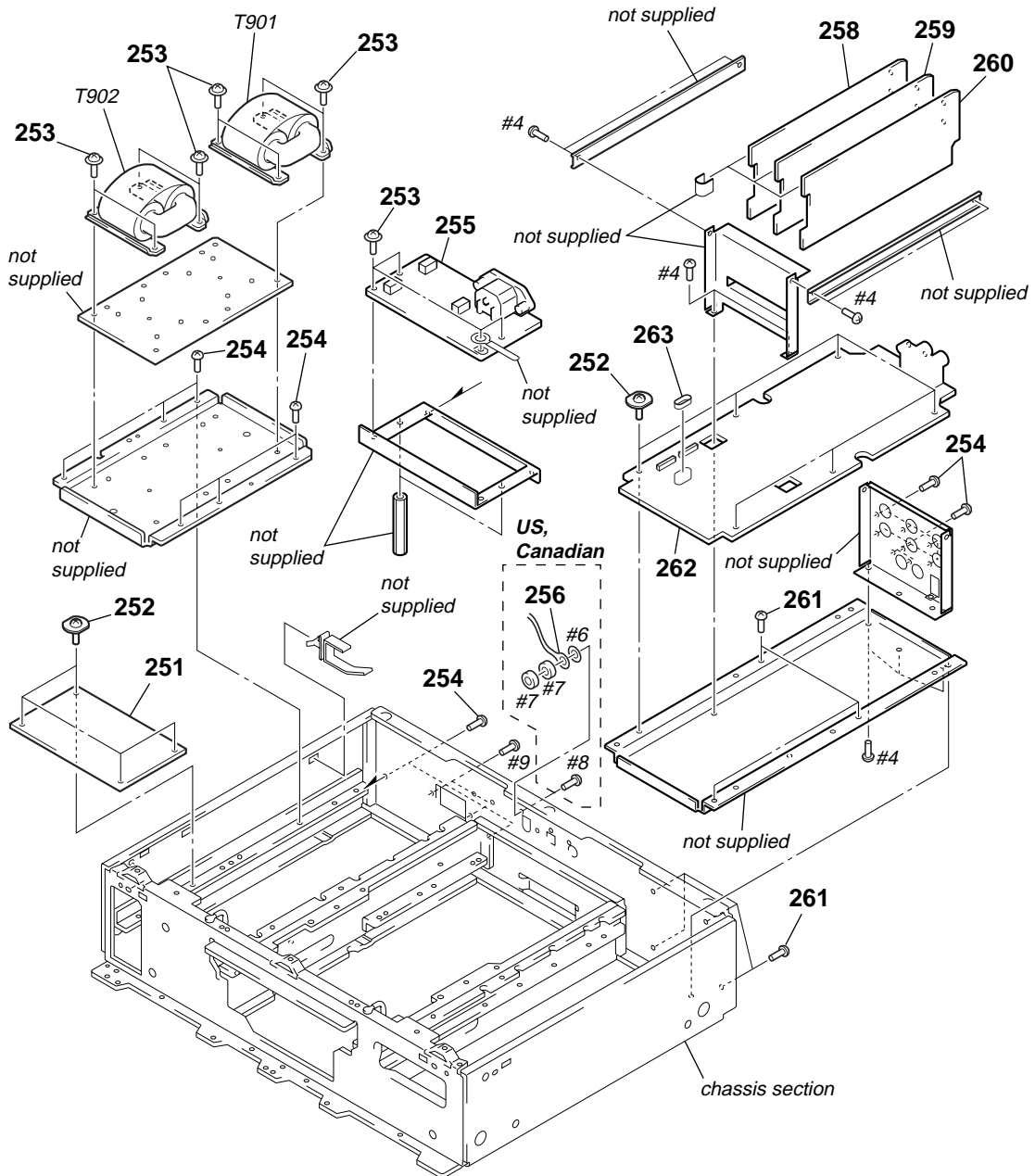

<p>The components identified by mark Δ or dotted line with mark Δ are critical for safety. Replace only with part number specified.</p>	<p>Les composants identifiés par une marque Δ sont critiques pour la sécurité. Ne les remplacer que par une pièce portant le numéro spécifié.</p>
---	---

Ref. No.	Part No.	Description	Remark	Ref. No.	Part No.	Description	Remark
251	A-4747-507-A	D-POWER BOARD, COMPLETE (AEP)		262	A-4747-510-A	MOTHER BOARD, COMPLETE (AEP)	
251	A-4747-599-A	D-POWER BOARD, COMPLETE (EXCEPT AEP)		262	A-4747-598-A	MOTHER BOARD, COMPLETE (EXCEPT AEP)	
252	X-4954-269-1	SCREW ASSY, + BVTT		263	4-211-300-01	RING, RUBBER	
253	3-703-249-22	SCREW, S TIGHT, +PTTWH (M3X8)		Δ T901	1-437-420-12	TRANSFORMER, POWER (AEP)	
254	4-929-074-01	SCREW (3X8)		Δ T901	1-437-422-12	TRANSFORMER, POWER (EXCEPT AEP)	
255	A-4751-591-A	AC BOARD, COMPLETE (Taiwan)		Δ T902	1-437-421-12	TRANSFORMER, POWER (AEP)	
255	A-4747-508-A	AC BOARD, COMPLETE (EXCEPT Taiwan)		Δ T902	1-437-423-12	TRANSFORMER, POWER (EXCEPT AEP)	
256	1-555-724-00	WIRE, GROUND (US, Canadian)		#4	7-685-871-01	SCREW +BVTT 3X6 (S)	
258	A-4747-498-A	AUDIO C/SW BOARD, COMPLETE		#6	7-623-423-07	LW 4, TYPE B (US, Canadian)	
259	A-4747-497-A	AUDIO SURR BOARD, COMPLETE		#7	7-684-024-04	N 4, TYPE 2 (US, Canadian)	
260	A-4747-496-A	AUDIO FRONT BOARD, COMPLETE		#8	7-682-964-09	SCREW +PSW 4X14 (US, Canadian)	
261	3-703-685-32	SCREW (+BV 3X8)		#9	7-685-659-79	SCREW +BVTP 4X8 TYPE2 N-S	

6-7. CHASSIS SECTION

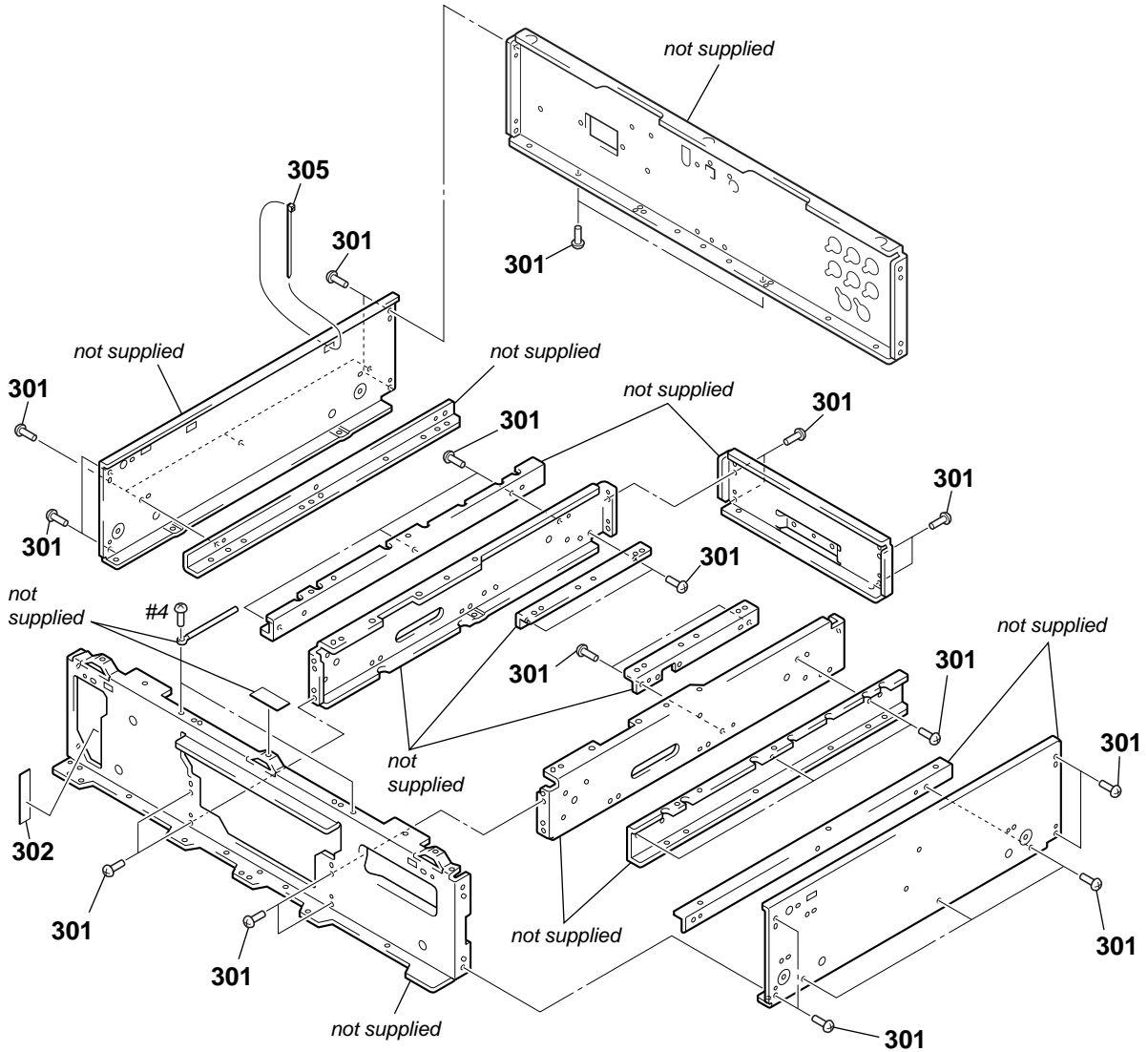

Ref. No.	Part No.	Description	Remark	Ref. No.	Part No.	Description	Remark
301	4-929-074-01	SCREW (3X8)		305	3-655-653-01	BAND (TAITON), BINDING	
* 302	4-615-354-01	SPACER		#4	7-685-871-01	SCREW +BVTT 3X6 (S)	

6-8. MECHANISM DECK SECTION
(CDM19JB-DVBU4C: Except AEP (Silver type))
(CDM19JB-DVBU4D: AEP (Silver type))

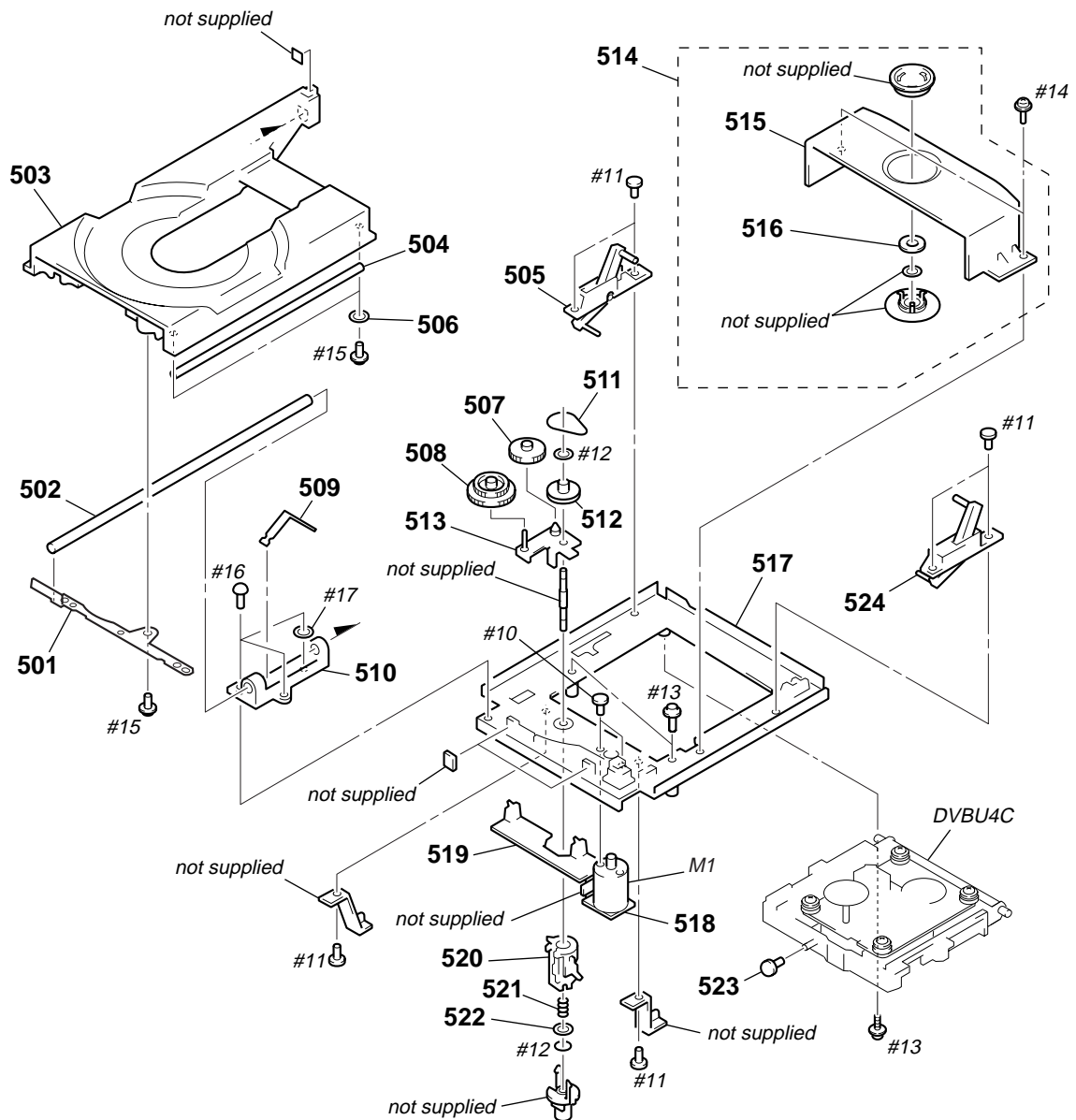

Ref. No.	Part No.	Description	Remark	Ref. No.	Part No.	Description	Remark
* 501	4-948-370-01	BRACKET (LOADING PANEL)		* 518	1-641-765-13	LOADING MOTOR BOARD	
* 502	4-948-368-01	BAR (MAIN), GUIDE		* 519	1-641-764-13	SW BOARD	
503	4-948-353-08	TABLE, DISC		* 520	4-948-371-01	CAM (BU)	
* 504	4-948-369-01	BAR (SUB), GUIDE		521	3-659-338-00	SPRING, COMPRESSION	
505	A-4604-913-A	LOCK (L) ASSY, STABLE		522	4-927-654-01	WASHER (LIMITER)	
506	4-927-318-01	WASHER		523	4-927-631-01	ROLLER (L)	
507	4-967-268-01	GEAR (C)		524	A-4604-914-A	LOCK (R) ASSY, STABLE	
508	4-927-620-04	GEAR (P)		M1	A-4604-347-A	MOTOR (L) ASSY (LOADING)	
* 509	4-927-648-01	SLIDER (GROUND)		#10	7-682-544-04	SCREW +P 3X3	
* 510	4-948-360-01	BEARING, LOADING		#11	7-685-871-09	SCREW +BVTT 3X6 (S)	
511	4-927-649-01	BELT		#12	7-624-105-04	STOP RING 2.3, TYPE-E	
512	4-929-724-01	PULLEY (B)		#13	7-685-903-21	+PTPWH 3X8 (TYPE2)	
513	X-4927-608-1	ARM ASSY, SWING		#14	7-682-547-04	+B 3X6	
514	A-4735-483-A	HOLDER (A.P.) ASSY		#15	7-685-646-79	SCREW +BVTP 3X8 TYPE2 IT-3	
* 515	4-948-356-03	HOLDER (A.P.)		#16	7-685-872-09	SCREW +BVTT 3X8 (S)	
516	3-053-844-01	YOKE		#17	7-685-003-12	W 3, MIDDLE	
* 517	4-948-355-05	CHASSIS (OUTSERT)					

6-9. BASE UNIT SECTION

(DVBU4C: Except AEP (Silver type))
 (DVBU4D: AEP (Silver type))

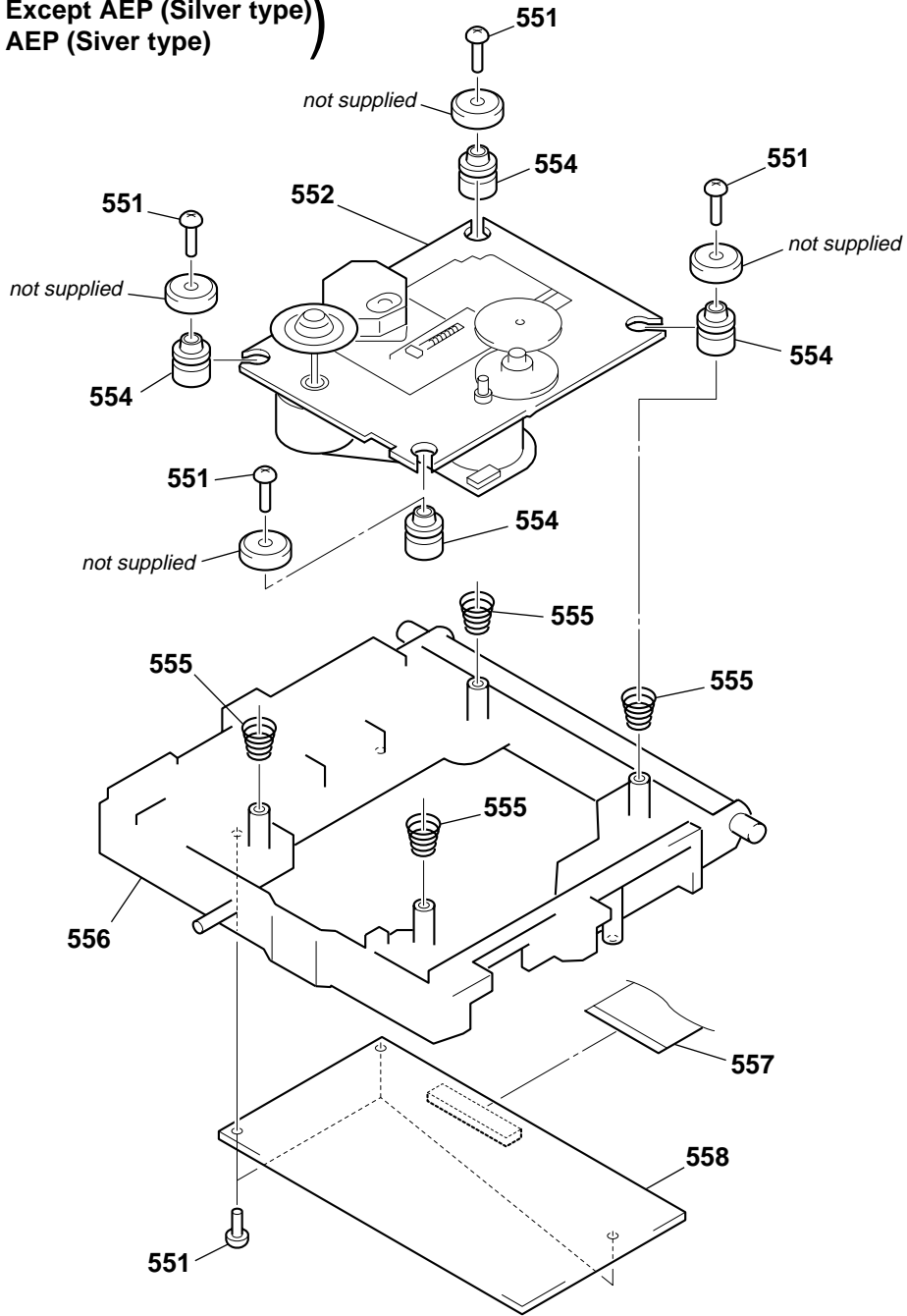

The components identified by mark \triangle or dotted line with mark \triangle are critical for safety. Replace only with part number specified.	Les composants identifiés par marque \triangle sont critiques pour la sécurité. Ne les remplacer que par une pièce portant le numéro spécifié.
--	--

Ref. No.	Part No.	Description	Remark	Ref. No.	Part No.	Description	Remark
551	3-087-053-01	+BVTP 2.6 (3CR)		556	4-228-669-01	HOLDER (KHM230)	
\triangle 552	8-820-132-03	OPTICAL PICK-UP (KHM-230AAA/J1RP) (EXCEPT AEP: SILVER)		557	1-757-097-11	WIRE (FLAT TYPE) (25 CORE)	
\triangle 552	8-820-132-09	OPTICAL PICK-UP (KHM-230AAA/J1RP1) (AEP: SILVER)		558	A-4747-590-A	RF BOARD, COMPLETE (EXCEPT AEP: SILVER)	
554	4-227-549-11	INSULATOR		558	A-1167-570-A	RF BOARD, COMPLETE (AEP: SILVER)	
555	4-231-449-11	SPRING (230), CONE TYPE COIL					

SECTION 7 ELECTRICAL PARTS LIST

AC	AC SW
A-POWER	

NOTE:

- Due to standardization, replacements in the parts list may be different from the parts specified in the diagrams or the components used on the set.
- -XX and -X mean standardized parts, so they may have some difference from the original one.
- RESISTORS
All resistors are in ohms.
METAL: Metal-film resistor.
METAL OXIDE: Metal oxide-film resistor.
F: nonflammable

- Items marked “*” are not stocked since they are seldom required for routine service. Some delay should be anticipated when ordering these items.
- SEMICONDUCTORS
In each case, u: μ , for example:
uA. . : μ A. . uPA. . : μ PA. .
uPB. . : μ PB. . uPC. . : μ PC. .
uPD. . : μ PD. .
- CAPACITORS
uF: μ F
- COILS
uH: μ H

The components identified by mark Δ or dotted line with mark Δ are critical for safety. Replace only with part number specified.

Les composants identifiés par une marque Δ sont critiques pour la sécurité. Ne les remplacer que par une pièce portant le numéro spécifié.

When indicating parts by reference number, please include the board.

Ref. No.	Part No.	Description	Remark	Ref. No.	Part No.	Description	Remark
	A-4747-508-A	AC BOARD, COMPLETE (EXCEPT Taiwan)			A-4747-511-A	A-POWER BOARD, COMPLETE (AEP)	
	A-4751-591-A	AC BOARD, COMPLETE (Taiwan)			A-4747-600-A	A-POWER BOARD, COMPLETE (EXCEPT AEP)	
		*****				*****	
		< CAPACITOR >					
Δ	C491	1-113-927-11 CERAMIC	0.01uF 250V				
Δ	C492	1-113-927-11 CERAMIC	0.01uF 250V				
Δ	C493	1-113-927-11 CERAMIC	0.01uF 250V				
Δ	C494	1-113-927-11 CERAMIC	0.01uF 250V				
Δ	C495	1-113-927-11 CERAMIC	0.01uF 250V				
Δ	C496	1-113-927-11 CERAMIC	0.01uF 250V				
		< CONNECTOR >					
	CN491	1-770-128-11 PIN, CONNECTOR (3.96mm PITCH) 2P					
*	CN492	1-564-321-21 PIN, CONNECTOR (3.96mm PITCH) 2P					
	CN493	1-564-321-00 PIN, CONNECTOR (3.96mm PITCH) 2P					
		< GROUND TERMINAL >					
	ETP401	1-537-770-21 TERMINAL BOARD, GROUND					
		< JACK >					
Δ	J491	1-251-234-11 INLET, AC (AC IN) (EXCEPT Taiwan)					
Δ	J491	1-816-148-11 INLET, AC (AC IN) (Taiwan)					
		< TRANSFORMER >					
Δ	T491	1-421-915-11 COIL, LINE FILTER					
Δ	T492	1-421-915-11 COIL, LINE FILTER					

		< CAPACITOR >					
		1-689-071-11 AC SW BOARD					

		< CAPACITOR >					
Δ	C996	1-113-927-11 CERAMIC	0.01uF 250V				
		< CONNECTOR >					
*	CN994	1-695-044-11 PIN, CONNECTOR (3.96mm PITCH) 2P					
		< SWITCH >					
Δ	S990	1-572-267-51 SWITCH, PUSH (AC POWER) (1 KEY) (POWER)					

		< CAPACITOR >					
		2-259-121-01 SCREW, TR					
*		4-931-401-01 HEAT SINK, V.0UT					
		< CAPACITOR >					
	C401	1-136-818-11 FILM	0.0047uF 5% 100V				
	C402	1-136-818-11 FILM	0.0047uF 5% 100V				
	C403	1-137-626-11 ELECT	6800uF 20% 35V				
	C404	1-137-626-11 ELECT	6800uF 20% 35V				
	C405	1-109-857-11 ELECT	47uF 20% 63V				
	C406	1-127-714-21 FILM	12000PF 5% 50V				
	C407	1-109-857-11 ELECT	47uF 20% 63V				
	C408	1-127-714-21 FILM	12000PF 5% 50V				
	C409	1-128-091-11 ELECT	1000uF 20% 50V				
	C410	1-128-091-11 ELECT	1000uF 20% 50V				
	C413	1-136-818-11 FILM	0.0047uF 5% 100V				
	C414	1-136-818-11 FILM	0.0047uF 5% 100V				
	C415	1-137-626-11 ELECT	6800uF 20% 35V				
	C416	1-128-197-11 ELECT	10uF 20% 63V				
	C417	1-128-091-11 ELECT	1000uF 20% 50V				
	C418	1-125-853-21 FILM	470PF 5% 50V (EXCEPT AEP)				
	C464	1-136-850-11 MYLAR	0.1uF 5% 63V				
	C465	1-136-850-11 MYLAR	0.1uF 5% 63V				
	C466	1-135-697-11 ELECT	6800uF 16V				
	C468	1-135-836-11 ELECT	2200uF 16V				
	C470	1-135-836-11 ELECT	2200uF 16V				
	C471	1-136-850-11 MYLAR	0.1uF 5% 63V				
	C472	1-136-850-11 MYLAR	0.1uF 5% 63V				
	C473	1-135-698-11 ELECT	10000uF 16V				
	C474	1-135-673-11 ELECT	4700uF 10V				
	C475	1-119-782-11 ELECT	1000uF 20% 10V				
	C477	1-135-836-11 ELECT	2200uF 16V				
	C479	1-135-698-11 ELECT	10000uF 16V				
		< CONNECTOR >					
	CN401	1-691-767-11 PLUG (MICRO CONNECTOR) 5P					
*	CN402	1-691-774-11 PLUG (MICRO CONNECTOR) 12P					
	CN403	1-691-770-21 PLUG (MICRO CONNECTOR) 8P					
	CN404	1-691-765-11 PLUG (MICRO CONNECTOR) 3P					
	CN452	1-691-766-11 PLUG (MICRO CONNECTOR) 4P					

SCD-XA9000ES

Ver 1.2

A-POWER

AUDIO C/SW

Ref. No.	Part No.	Description	Remark	Ref. No.	Part No.	Description	Remark
< DIODE >							
D401	8-719-079-01	DIODE FRH10A15		R402	1-259-991-11	CARBON MELF 470	2% 1/8W
D402	8-719-079-01	DIODE FRH10A15		R403	1-259-991-11	CARBON MELF 470	2% 1/8W
D403	8-719-079-00	DIODE FCH10A15		R404	1-259-979-11	CARBON MELF 47	2% 1/8W
D404	8-719-079-00	DIODE FCH10A15		R405	1-259-995-11	CARBON MELF 1K	2% 1/8W
D405	8-719-210-39	DIODE EC10QS-04		R406	1-259-995-11	CARBON MELF 1K	2% 1/8W
D406	8-719-210-39	DIODE EC10QS-04		R407	1-259-995-11	CARBON MELF 1K	2% 1/8W
D407	8-719-210-39	DIODE EC10QS-04		R408	1-259-995-11	CARBON MELF 1K	2% 1/8W
D408	8-719-210-39	DIODE EC10QS-04		R409	1-259-983-11	CARBON MELF 100	2% 1/8W
D409	8-719-069-54	DIODE UDZSTE-175.1B		R410	1-259-983-11	CARBON MELF 100	2% 1/8W
D410	8-719-069-54	DIODE UDZSTE-175.1B		R411	1-259-997-11	CARBON MELF 1.5K	2% 1/8W
D411	8-719-210-39	DIODE EC10QS-04		R412	1-259-995-11	CARBON MELF 1K	2% 1/8W
D459	8-719-210-39	DIODE EC10QS-04		R413	1-259-997-11	CARBON MELF 1.5K	2% 1/8W
D460	8-719-210-39	DIODE EC10QS-04		R414	1-259-995-11	CARBON MELF 1K	2% 1/8W
D461	8-719-210-39	DIODE EC10QS-04		R415	1-260-012-11	CARBON MELF 22K	2% 1/8W
D462	8-719-210-39	DIODE EC10QS-04		R457	1-216-073-00	RES-CHIP 10K	5% 1/10W
D463	8-719-210-39	DIODE EC10QS-04		R458	1-216-073-00	RES-CHIP 10K	5% 1/10W
D464	8-719-210-39	DIODE EC10QS-04		R459	1-216-073-00	RES-CHIP 10K	5% 1/10W
D465	8-719-210-39	DIODE EC10QS-04		R460	1-216-073-00	RES-CHIP 10K	5% 1/10W
D466	8-719-210-39	DIODE EC10QS-04		R464	1-216-073-00	RES-CHIP 10K	5% 1/10W
< EARTH TERMINAL >				< THERMISTOR (POSITIVE) >			
EPT403	1-537-770-21	TERMINAL BOARD, GROUND (EXCEPT AEP)		THP452	1-801-578-11	THERMISTOR, POSITIVE	
				THP453	1-801-696-11	THERMISTOR, POSITIVE	

< IC >				A-4747-498-A AUDIO C/SW BOARD, COMPLETE			
IC401	8-759-566-39	IC OPA2132UA/2K5		*****			
IC402	8-759-566-39	IC OPA2132UA/2K5		< CAPACITOR >			
IC403	8-759-231-53	IC TA7805S		C2101	1-109-857-11	ELECT 47uF	20% 63V
IC452	8-759-450-47	IC BA05T		C2102	1-130-973-00	MYLAR 0.022uF	5% 100V
IC453	8-759-450-47	IC BA05T		C2103	1-109-857-11	ELECT 47uF	20% 63V
IC454	8-759-445-59	IC BA033T		C2105	1-128-197-11	ELECT 10uF	20% 63V
IC455	8-759-445-59	IC BA033T		C2106	1-128-197-11	ELECT 10uF	20% 63V
< COIL >				C2107	1-130-973-00	MYLAR 0.022uF	5% 100V
L401	1-424-122-11	FILTER, NOISE		C2108	1-109-857-11	ELECT 47uF	20% 63V
L402	1-424-122-11	FILTER, NOISE		C2109	1-128-197-11	ELECT 10uF	20% 63V
L403	1-424-122-11	FILTER, NOISE		C2110	1-136-819-11	FILM 0.0068uF	5% 100V
L404	1-424-122-11	FILTER, NOISE		C2111	1-136-819-11	FILM 0.0068uF	5% 100V
L405	1-424-122-11	FILTER, NOISE		C2112	1-136-817-11	FILM 0.0033uF	5% 100V
L406	1-424-122-11	FILTER, NOISE		C2113	1-136-814-11	FILM 0.001uF	5% 100V
L407	1-424-122-11	FILTER, NOISE		C2114	1-136-817-11	FILM 0.0033uF	5% 100V
L457	1-424-122-11	FILTER, NOISE		C2115	1-136-814-11	FILM 0.001uF	5% 100V
L458	1-424-122-11	FILTER, NOISE		C2116	1-136-818-11	FILM 0.0047uF	5% 100V
L459	1-424-122-11	FILTER, NOISE		C2117	1-136-810-11	FILM 220PF	5% 100V
L460	1-424-122-11	FILTER, NOISE		C2118	1-136-960-11	FILM 0.1uF	10% 160V
< TRANSISTOR >				C2119	1-128-201-11	ELECT 100uF	20% 63V
Q401	8-729-107-53	TRANSISTOR 2SC2275A-P		C2120	1-128-201-11	ELECT 100uF	20% 63V
Q402	8-729-107-53	TRANSISTOR 2SC2275A-P		C2151	1-110-495-11	ELECT 220uF	20% 25V
Q403	8-729-141-10	TRANSISTOR 2SA985A-QP		C2152	1-119-803-11	ELECT 470uF	20% 25V
Q404	8-729-141-10	TRANSISTOR 2SA985A-QP		C2153	1-164-506-11	CERAMIC CHIP 4.7uF	16V
Q405	8-729-036-56	FET 2SK208-GR-TE85L		C2154	1-128-201-11	ELECT 100uF	20% 63V
Q406	8-729-036-56	FET 2SK208-GR-TE85L		C2155	1-128-201-11	ELECT 100uF	20% 63V
< RESISTOR >				C2156	1-130-973-00	MYLAR 0.022uF	5% 100V
R401	1-259-979-11	CARBON MELF 47	2% 1/8W	C2157	1-130-973-00	MYLAR 0.022uF	5% 100V
				C2158	1-130-973-00	MYLAR 0.022uF	5% 100V
				C2159	1-130-973-00	MYLAR 0.022uF	5% 100V
				C2160	1-165-319-11	CERAMIC CHIP 0.1uF	50V
				C2161	1-165-319-11	CERAMIC CHIP 0.1uF	50V

AUDIO C/SW

Ref. No.	Part No.	Description	Remark	Ref. No.	Part No.	Description	Remark
C2162	1-119-800-11	ELECT	100uF 20% 25V	IC2201	8-759-836-44	IC CXD9657N/2K	
C2163	1-165-319-11	CERAMIC CHIP	0.1uF 50V	IC2202	8-759-566-39	IC OPA2132UA/2K5	
C2164	1-165-319-11	CERAMIC CHIP	0.1uF 50V	IC2203	8-759-566-39	IC OPA2132UA/2K5	
C2165	1-110-495-11	ELECT	220uF 20% 25V			< JACK >	
C2166	1-165-319-11	CERAMIC CHIP	0.1uF 50V	J2301	1-815-744-11	JACK, PIN 2P (ANALOG 5.1CH OUT CENTER/SUB WOOFER)	
C2180	1-117-720-11	CERAMIC CHIP	4.7uF 10V			< COIL >	
C2181	1-163-141-00	CERAMIC CHIP	0.001uF 5% 50V	L2102	1-408-619-31	MICRO INDUCTOR	220uH
C2201	1-109-857-11	ELECT	47uF 20% 63V	L2202	1-408-619-31	MICRO INDUCTOR	220uH
C2202	1-130-973-00	MYLAR	0.022uF 5% 100V			< TRANSISTOR >	
C2203	1-109-857-11	ELECT	47uF 20% 63V	Q2151	8-729-207-71	TRANSISTOR	RN2405
C2205	1-128-197-11	ELECT	10uF 20% 63V	Q2152	8-729-027-43	TRANSISTOR	DTC114EKA-T146
C2206	1-128-197-11	ELECT	10uF 20% 63V	Q2153	8-729-207-71	TRANSISTOR	RN2405
C2207	1-130-973-00	MYLAR	0.022uF 5% 100V	Q2154	8-729-027-43	TRANSISTOR	DTC114EKA-T146
C2208	1-109-857-11	ELECT	47uF 20% 63V	Q2155	8-729-207-71	TRANSISTOR	RN2405
C2209	1-128-197-11	ELECT	10uF 20% 63V	Q2156	8-729-027-43	TRANSISTOR	DTC114EKA-T146
C2210	1-136-819-11	FILM	0.0068uF 5% 100V			< RESISTOR >	
C2211	1-136-819-11	FILM	0.0068uF 5% 100V	R2101	1-259-937-11	CARBON MELF	16K 2% 1/8W
C2212	1-136-817-11	FILM	0.0033uF 5% 100V	R2103	1-259-979-11	CARBON MELF	47 2% 1/8W
C2213	1-136-814-11	FILM	0.001uF 5% 100V	R2104	1-259-979-11	CARBON MELF	47 2% 1/8W
C2214	1-136-817-11	FILM	0.0033uF 5% 100V	R2105	1-259-979-11	CARBON MELF	47 2% 1/8W
C2215	1-136-814-11	FILM	0.001uF 5% 100V	R2106	1-259-979-11	CARBON MELF	47 2% 1/8W
C2216	1-136-818-11	FILM	0.0047uF 5% 100V	R2107	1-259-991-11	CARBON MELF	470 2% 1/8W
C2217	1-136-810-11	FILM	220PF 5% 100V	R2108	1-259-991-11	CARBON MELF	470 2% 1/8W
C2218	1-136-960-11	FILM	0.1uF 10% 160V	R2109	1-259-998-11	CARBON MELF	1.8K 2% 1/8W
C2219	1-128-201-11	ELECT	100uF 20% 63V	R2110	1-259-998-11	CARBON MELF	1.8K 2% 1/8W
C2220	1-128-201-11	ELECT	100uF 20% 63V	R2111	1-259-925-11	CARBON MELF	1.6K 2% 1/8W
C2256	1-130-973-00	MYLAR	0.022uF 5% 100V	R2112	1-259-998-11	CARBON MELF	1.8K 2% 1/8W
C2257	1-130-973-00	MYLAR	0.022uF 5% 100V	R2113	1-259-998-11	CARBON MELF	1.8K 2% 1/8W
C2258	1-130-973-00	MYLAR	0.022uF 5% 100V	R2114	1-259-925-11	CARBON MELF	1.6K 2% 1/8W
C2259	1-130-973-00	MYLAR	0.022uF 5% 100V	R2115	1-260-002-11	CARBON MELF	3.3K 2% 1/8W
		< CONNECTOR >		R2116	1-260-001-11	CARBON MELF	2.7K 2% 1/8W
* CN2101	1-774-629-11	CONNECTOR, BOARD TO BOARD 17P		R2117	1-260-002-11	CARBON MELF	3.3K 2% 1/8W
* CN2102	1-770-727-11	CONNECTOR, BOARD TO BOARD 8P		R2118	1-260-028-11	CARBON MELF	470K 2% 1/8W
		< DIODE >		R2119	1-259-971-11	CARBON MELF	10 2% 1/8W
D2151	8-719-069-60	DIODE UDZSTE-179.1B		R2120	1-259-983-11	CARBON MELF	100 2% 1/8W
D2152	8-719-069-60	DIODE UDZSTE-179.1B		R2151	1-216-073-00	RES-CHIP	10K 5% 1/10W
D2153	8-719-016-74	DIODE 1SS352		R2153	1-216-025-11	RES-CHIP	100 5% 1/10W
D2154	8-719-016-74	DIODE 1SS352		R2154	1-216-025-11	RES-CHIP	100 5% 1/10W
D2155	8-719-049-09	DIODE 1SS367-T3SONY		R2155	1-216-025-11	RES-CHIP	100 5% 1/10W
D2156	8-719-016-74	DIODE 1SS352		R2156	1-216-025-11	RES-CHIP	100 5% 1/10W
D2157	8-719-069-60	DIODE UDZSTE-179.1B		R2157	1-216-025-11	RES-CHIP	100 5% 1/10W
		< RESISTOR >		R2159	1-216-073-00	RES-CHIP	10K 5% 1/10W
△FR2101	1-212-881-11	FUSIBLE	100 5% 1/4W	R2160	1-216-081-00	RES-CHIP	22K 5% 1/10W
△FR2151	1-212-881-11	FUSIBLE	100 5% 1/4W	R2161	1-216-025-11	RES-CHIP	100 5% 1/10W
△FR2152	1-212-881-11	FUSIBLE	100 5% 1/4W	R2162	1-216-041-00	RES-CHIP	470 5% 1/10W
△FR2153	1-212-865-00	FUSIBLE	22 5% 1/4W	R2163	1-216-025-11	RES-CHIP	100 5% 1/10W
△FR2154	1-212-881-11	FUSIBLE	100 5% 1/4W	R2164	1-216-025-11	RES-CHIP	100 5% 1/10W
△FR2201	1-212-881-11	FUSIBLE	100 5% 1/4W	R2165	1-216-025-11	RES-CHIP	100 5% 1/10W
		< IC >		R2166	1-216-081-00	RES-CHIP	22K 5% 1/10W
IC2101	8-759-836-44	IC CXD9657N/2K		R2180	1-216-073-00	RES-CHIP	10K 5% 1/10W
IC2102	8-759-566-39	IC OPA2132UA/2K5		R2181	1-216-298-00	RES-CHIP	2.2 5% 1/10W
IC2103	8-759-566-39	IC OPA2132UA/2K5					
IC2151	8-759-486-55	IC NJM2370U33-TE2					

The components identified by mark △ or dotted line with mark △ are critical for safety. Replace only with part number specified.

Les composants identifiés par une marque △ sont critiques pour la sécurité. Ne les remplacer que par une pièce portant le numéro spécifié.

AUDIO C/SW

AUDIO FRONT

Ref. No.	Part No.	Description	Remark
R2201	1-259-937-11	CARBON MELF 16K	2% 1/8W
R2203	1-259-979-11	CARBON MELF 47	2% 1/8W
R2204	1-259-979-11	CARBON MELF 47	2% 1/8W
R2205	1-259-979-11	CARBON MELF 47	2% 1/8W
R2206	1-259-979-11	CARBON MELF 47	2% 1/8W
R2207	1-259-991-11	CARBON MELF 470	2% 1/8W
R2208	1-259-991-11	CARBON MELF 470	2% 1/8W
R2209	1-259-998-11	CARBON MELF 1.8K	2% 1/8W
R2210	1-259-998-11	CARBON MELF 1.8K	2% 1/8W
R2211	1-259-925-11	CARBON MELF 1.6K	2% 1/8W
R2212	1-259-998-11	CARBON MELF 1.8K	2% 1/8W
R2213	1-259-998-11	CARBON MELF 1.8K	2% 1/8W
R2214	1-259-925-11	CARBON MELF 1.6K	2% 1/8W
R2215	1-260-002-11	CARBON MELF 3.3K	2% 1/8W
R2216	1-260-001-11	CARBON MELF 2.7K	2% 1/8W
R2217	1-260-002-11	CARBON MELF 3.3K	2% 1/8W
R2218	1-260-028-11	CARBON MELF 470K	2% 1/8W
R2219	1-259-971-11	CARBON MELF 10	2% 1/8W
R2220	1-259-983-11	CARBON MELF 100	2% 1/8W
R2221	1-260-002-11	CARBON MELF 3.3K	2% 1/8W
< RELAY >			
RY2151	1-755-295-11	RELAY	
RY2152	1-755-295-11	RELAY	
RY2153	1-755-295-11	RELAY	

A-4747-496-A	AUDIO FRONT BOARD, COMPLETE		

< CAPACITOR >			
C101	1-109-857-11	ELECT 47uF 20%	63V
C102	1-130-973-00	MYLAR 0.022uF 5%	100V
C103	1-109-857-11	ELECT 47uF 20%	63V
C105	1-128-197-11	ELECT 10uF 20%	63V
C106	1-128-197-11	ELECT 10uF 20%	63V
C107	1-130-973-00	MYLAR 0.022uF 5%	100V
C108	1-109-857-11	ELECT 47uF 20%	63V
C109	1-128-197-11	ELECT 10uF 20%	63V
C110	1-136-819-11	FILM 0.0068uF 5%	100V
C111	1-136-819-11	FILM 0.0068uF 5%	100V
C112	1-136-817-11	FILM 0.0033uF 5%	100V
C113	1-136-814-11	FILM 0.001uF 5%	100V
C114	1-136-817-11	FILM 0.0033uF 5%	100V
C115	1-136-814-11	FILM 0.001uF 5%	100V
C116	1-136-818-11	FILM 0.0047uF 5%	100V
C117	1-136-810-11	FILM 220PF 5%	100V
C118	1-136-960-11	FILM 0.1uF 10%	160V
C119	1-128-201-11	ELECT 100uF 20%	63V
C120	1-128-201-11	ELECT 100uF 20%	63V
C151	1-110-495-11	ELECT 220uF 20%	25V
C152	1-119-803-11	ELECT 470uF 20%	25V
C153	1-164-506-11	CERAMIC CHIP 4.7uF	16V
C154	1-128-201-11	ELECT 100uF 20%	63V
C155	1-128-201-11	ELECT 100uF 20%	63V
C156	1-130-973-00	MYLAR 0.022uF 5%	100V
C157	1-130-973-00	MYLAR 0.022uF 5%	100V
C158	1-130-973-00	MYLAR 0.022uF 5%	100V
C159	1-130-973-00	MYLAR 0.022uF 5%	100V

Ref. No.	Part No.	Description	Remark
C160	1-165-319-11	CERAMIC CHIP 0.1uF	50V
C162	1-119-800-11	ELECT 100uF 20%	25V
C163	1-165-319-11	CERAMIC CHIP 0.1uF	50V
C164	1-165-319-11	CERAMIC CHIP 0.1uF	50V
C165	1-110-495-11	ELECT 220uF 20%	25V
C181	1-163-141-00	CERAMIC CHIP 0.001uF	5% 50V
C201	1-109-857-11	ELECT 47uF 20%	63V
C202	1-130-973-00	MYLAR 0.022uF 5%	100V
C203	1-109-857-11	ELECT 47uF 20%	63V
C205	1-128-197-11	ELECT 10uF 20%	63V
C206	1-128-197-11	ELECT 10uF 20%	63V
C207	1-130-973-00	MYLAR 0.022uF 5%	100V
C208	1-109-857-11	ELECT 47uF 20%	63V
C209	1-128-197-11	ELECT 10uF 20%	63V
C210	1-136-819-11	FILM 0.0068uF 5%	100V
C211	1-136-819-11	FILM 0.0068uF 5%	100V
C212	1-136-817-11	FILM 0.0033uF 5%	100V
C213	1-136-814-11	FILM 0.001uF 5%	100V
C214	1-136-817-11	FILM 0.0033uF 5%	100V
C215	1-136-814-11	FILM 0.001uF 5%	100V
C216	1-136-818-11	FILM 0.0047uF 5%	100V
C217	1-136-810-11	FILM 220PF 5%	100V
C218	1-136-960-11	FILM 0.1uF 10%	160V
C219	1-128-201-11	ELECT 100uF 20%	63V
C220	1-128-201-11	ELECT 100uF 20%	63V
C256	1-130-973-00	MYLAR 0.022uF 5%	100V
C257	1-130-973-00	MYLAR 0.022uF 5%	100V
C258	1-130-973-00	MYLAR 0.022uF 5%	100V
C259	1-130-973-00	MYLAR 0.022uF 5%	100V
< CONNECTOR >			
* CN101	1-770-732-11	CONNECTOR, BOARD TO BOARD 15P	
* CN102	1-770-727-11	CONNECTOR, BOARD TO BOARD 8P	
< DIODE >			
D152	8-719-069-60	DIODE UDZSTE-179.1B	
D154	8-719-016-74	DIODE 1SS352	
D155	8-719-049-09	DIODE 1SS367-T3SONY	
< RESISTOR >			
△ FR101	1-212-881-11	FUSIBLE 100 5%	1/4W
△ FR152	1-212-881-11	FUSIBLE 100 5%	1/4W
△ FR153	1-212-865-00	FUSIBLE 22 5%	1/4W
△ FR201	1-212-881-11	FUSIBLE 100 5%	1/4W
< IC >			
IC101	8-759-836-44	IC CXD9657N/2K	
IC102	8-759-566-39	IC OPA2132UA/2K5	
IC103	8-759-566-39	IC OPA2132UA/2K5	
IC151	8-759-486-55	IC NJM2370U33-TE2	
IC201	8-759-836-44	IC CXD9657N/2K	
IC202	8-759-566-39	IC OPA2132UA/2K5	
IC203	8-759-566-39	IC OPA2132UA/2K5	
< JACK >			
J301	1-815-743-11	JACK, PIN 2P (ANALOG 5.1CH OUT FRONT)	

The components identified by mark △ or dotted line with mark △ are critical for safety. Replace only with part number specified.

Les composants identifiés par une marque △ sont critiques pour la sécurité. Ne les remplacer que par une pièce portant le numéro spécifié.

AUDIO SURR

Ref. No.	Part No.	Description	Remark
C1211	1-136-819-11	FILM	0.0068uF 5% 100V
C1212	1-136-817-11	FILM	0.0033uF 5% 100V
C1213	1-136-814-11	FILM	0.001uF 5% 100V
C1214	1-136-817-11	FILM	0.0033uF 5% 100V
C1215	1-136-814-11	FILM	0.001uF 5% 100V
C1216	1-136-818-11	FILM	0.0047uF 5% 100V
C1217	1-136-810-11	FILM	220PF 5% 100V
C1218	1-136-960-11	FILM	0.1uF 10% 160V
C1219	1-128-201-11	ELECT	100uF 20% 63V
C1220	1-128-201-11	ELECT	100uF 20% 63V
C1256	1-130-973-00	MYLAR	0.022uF 5% 100V
C1257	1-130-973-00	MYLAR	0.022uF 5% 100V
C1258	1-130-973-00	MYLAR	0.022uF 5% 100V
C1259	1-130-973-00	MYLAR	0.022uF 5% 100V
< CONNECTOR >			
* CN1101	1-770-732-11	CONNECTOR, BOARD TO BOARD 15P	
* CN1102	1-770-727-11	CONNECTOR, BOARD TO BOARD 8P	
< DIODE >			
D1151	8-719-069-60	DIODE UDZSTE-179.1B	
D1152	8-719-069-60	DIODE UDZSTE-179.1B	
D1153	8-719-016-74	DIODE 1SS352	
D1154	8-719-016-74	DIODE 1SS352	
D1155	8-719-049-09	DIODE 1SS367-T3SONY	
< RESISTER >			
△FR1101	1-212-881-11	FUSIBLE	100 5% 1/4W
△FR1151	1-212-881-11	FUSIBLE	100 5% 1/4W
△FR1152	1-212-881-11	FUSIBLE	100 5% 1/4W
△FR1153	1-212-865-00	FUSIBLE	22 5% 1/4W
△FR1201	1-212-881-11	FUSIBLE	100 5% 1/4W
< IC >			
IC1101	8-759-836-44	IC CXD9657N/2K	
IC1102	8-759-566-39	IC OPA2132UA/2K5	
IC1103	8-759-566-39	IC OPA2132UA/2K5	
IC1151	8-759-486-55	IC NJM2370U33-TE2	
IC1201	8-759-836-44	IC CXD9657N/2K	
IC1202	8-759-566-39	IC OPA2132UA/2K5	
IC1203	8-759-566-39	IC OPA2132UA/2K5	
< JACK >			
J1301	1-815-743-11	JACK, PIN 2P	(ANALOG 5.1CH OUT SURROUND)
< COIL >			
L1102	1-408-619-31	MICRO INDUCTOR	220uH
L1202	1-408-619-31	MICRO INDUCTOR	220uH
< TRANSISTOR >			
Q1151	8-729-207-71	TRANSISTOR	RN2405
Q1152	8-729-027-43	TRANSISTOR	DTC114EKA-T146
Q1153	8-729-207-71	TRANSISTOR	RN2405
Q1154	8-729-027-43	TRANSISTOR	DTC114EKA-T146
< RESISTOR >			
R1101	1-259-937-11	CARBON MELF	16K 2% 1/8W

Ref. No.	Part No.	Description	Remark
R1103	1-259-979-11	CARBON MELF	47 2% 1/8W
R1104	1-259-979-11	CARBON MELF	47 2% 1/8W
R1105	1-259-979-11	CARBON MELF	47 2% 1/8W
R1106	1-259-979-11	CARBON MELF	47 2% 1/8W
R1107	1-259-991-11	CARBON MELF	470 2% 1/8W
R1108	1-259-991-11	CARBON MELF	470 2% 1/8W
R1109	1-259-998-11	CARBON MELF	1.8K 2% 1/8W
R1110	1-259-998-11	CARBON MELF	1.8K 2% 1/8W
R1111	1-259-925-11	CARBON MELF	1.6K 2% 1/8W
R1112	1-259-998-11	CARBON MELF	1.8K 2% 1/8W
R1113	1-259-998-11	CARBON MELF	1.8K 2% 1/8W
R1114	1-259-925-11	CARBON MELF	1.6K 2% 1/8W
R1115	1-260-002-11	CARBON MELF	3.3K 2% 1/8W
R1116	1-260-001-11	CARBON MELF	2.7K 2% 1/8W
R1117	1-260-002-11	CARBON MELF	3.3K 2% 1/8W
R1118	1-260-028-11	CARBON MELF	470K 2% 1/8W
R1119	1-259-971-11	CARBON MELF	10 2% 1/8W
R1120	1-259-983-11	CARBON MELF	100 2% 1/8W
R1151	1-216-073-00	RES-CHIP	10K 5% 1/10W
R1153	1-216-025-11	RES-CHIP	100 5% 1/10W
R1154	1-216-025-11	RES-CHIP	100 5% 1/10W
R1155	1-216-025-11	RES-CHIP	100 5% 1/10W
R1156	1-216-025-11	RES-CHIP	100 5% 1/10W
R1157	1-216-025-11	RES-CHIP	100 5% 1/10W
R1159	1-216-073-00	RES-CHIP	10K 5% 1/10W
R1160	1-216-081-00	RES-CHIP	22K 5% 1/10W
R1161	1-216-025-11	RES-CHIP	100 5% 1/10W
R1162	1-216-041-00	RES-CHIP	470 5% 1/10W
R1163	1-216-025-11	RES-CHIP	100 5% 1/10W
R1164	1-216-025-11	RES-CHIP	100 5% 1/10W
R1165	1-216-025-11	RES-CHIP	100 5% 1/10W
R1180	1-216-073-00	RES-CHIP	10K 5% 1/10W
R1181	1-216-298-00	RES-CHIP	2.2 5% 1/10W
R1201	1-259-937-11	CARBON MELF	16K 2% 1/8W
R1203	1-259-979-11	CARBON MELF	47 2% 1/8W
R1204	1-259-979-11	CARBON MELF	47 2% 1/8W
R1205	1-259-979-11	CARBON MELF	47 2% 1/8W
R1206	1-259-979-11	CARBON MELF	47 2% 1/8W
R1207	1-259-991-11	CARBON MELF	470 2% 1/8W
R1208	1-259-991-11	CARBON MELF	470 2% 1/8W
R1209	1-259-998-11	CARBON MELF	1.8K 2% 1/8W
R1210	1-259-998-11	CARBON MELF	1.8K 2% 1/8W
R1211	1-259-925-11	CARBON MELF	1.6K 2% 1/8W
R1212	1-259-998-11	CARBON MELF	1.8K 2% 1/8W
R1213	1-259-998-11	CARBON MELF	1.8K 2% 1/8W
R1214	1-259-925-11	CARBON MELF	1.6K 2% 1/8W
R1215	1-260-002-11	CARBON MELF	3.3K 2% 1/8W
R1216	1-260-001-11	CARBON MELF	2.7K 2% 1/8W
R1217	1-260-002-11	CARBON MELF	3.3K 2% 1/8W
R1218	1-260-028-11	CARBON MELF	470K 2% 1/8W
R1219	1-259-971-11	CARBON MELF	10 2% 1/8W
R1220	1-259-983-11	CARBON MELF	100 2% 1/8W
< RELAY >			
RY1151	1-755-295-11	RELAY	
RY1152	1-755-295-11	RELAY	

The components identified by mark △ or dotted line with mark △ are critical for safety. Replace only with part number specified.	Les composants identifiés par une marque △ sont critiques pour la sécurité. Ne les remplacer que par une pièce portant le numéro spécifié.
--	--

DISPLAY

D-OUT

Ref. No.	Part No.	Description	Remark	Ref. No.	Part No.	Description	Remark
	A-4747-500-A	DISPLAY BOARD, COMPLETE *****		R843	1-216-809-11	METAL CHIP 100 5%	1/10W
				R844	1-216-809-11	METAL CHIP 100 5%	1/10W
	2-389-320-01	CUSHION		R845	1-216-809-11	METAL CHIP 100 5%	1/10W
*	4-996-686-13	HOLDER (FL)		R846	1-216-809-11	METAL CHIP 100 5%	1/10W
		< CAPACITOR >		R847	1-216-833-11	METAL CHIP 10K 5%	1/10W
C801	1-131-992-91	CERAMIC CHIP 100000PF	35V	R848	1-216-833-11	METAL CHIP 10K 5%	1/10W
C802	1-124-584-00	ELECT 100uF 20%	6.3V	R849	1-216-833-11	METAL CHIP 10K 5%	1/10W
C803	1-131-992-91	CERAMIC CHIP 100000PF	35V	R850	1-216-833-11	METAL CHIP 10K 5%	1/10W
C804	1-162-964-11	CERAMIC CHIP 0.001uF 10%	50V	R851	1-216-805-11	METAL CHIP 47 5%	1/10W
C805	1-162-964-11	CERAMIC CHIP 0.001uF 10%	50V	R852	1-216-809-11	METAL CHIP 100 5%	1/10W
C806	1-131-992-91	CERAMIC CHIP 100000PF	35V	R868	1-216-833-11	METAL CHIP 10K 5%	1/10W
C807	1-131-992-91	CERAMIC CHIP 100000PF	35V	R871	1-216-833-11	METAL CHIP 10K 5%	1/10W
C810	1-131-992-91	CERAMIC CHIP 100000PF	35V	R872	1-216-833-11	METAL CHIP 10K 5%	1/10W
C811	1-162-964-11	CERAMIC CHIP 0.001uF 10%	50V	R873	1-216-833-11	METAL CHIP 10K 5%	1/10W
C812	1-162-964-11	CERAMIC CHIP 0.001uF 10%	50V	R874	1-216-833-11	METAL CHIP 10K 5%	1/10W
C813	1-162-964-11	CERAMIC CHIP 0.001uF 10%	50V	R875	1-216-833-11	METAL CHIP 10K 5%	1/10W
C814	1-162-964-11	CERAMIC CHIP 0.001uF 10%	50V	R876	1-216-833-11	METAL CHIP 10K 5%	1/10W
C815	1-162-949-11	CERAMIC CHIP 47PF 5%	50V	R877	1-216-833-11	METAL CHIP 10K 5%	1/10W
C816	1-162-964-11	CERAMIC CHIP 0.001uF 10%	50V	R878	1-216-833-11	METAL CHIP 10K 5%	1/10W
C817	1-162-964-11	CERAMIC CHIP 0.001uF 10%	50V	R880	1-216-833-11	METAL CHIP 10K 5%	1/10W
C818	1-162-964-11	CERAMIC CHIP 0.001uF 10%	50V	R881	1-216-833-11	METAL CHIP 10K 5%	1/10W
C819	1-162-964-11	CERAMIC CHIP 0.001uF 10%	50V	R882	1-216-833-11	METAL CHIP 10K 5%	1/10W
C833	1-124-584-00	ELECT 100uF 20%	6.3V			< VIBRATOR >	
C851	1-124-584-00	ELECT 100uF 20%	6.3V	X801	1-781-472-21	VIBRATOR, CERAMIC (8MHz)	
C880	1-131-992-91	CERAMIC CHIP 100000PF	35V			*****	
		< CONNECTOR >			A-4747-509-A	D-OUT BOARD, COMPLETE *****	
CN801	1-794-706-11	PIN, CONNECTOR 7P				< CAPACITOR >	
CN802	1-568-955-11	PIN, CONNECTOR 6P		C441	1-136-850-11	MYLAR 0.1uF 5%	63V
		< DIODE >		C442	1-104-645-11	CERAMIC 1uF 20%	50V
D805	8-719-988-61	DIODE 1SS355TE-17		C443	1-163-251-11	CERAMIC CHIP 100PF 5%	50V
		< FILTER >		C444	1-164-732-11	CERAMIC 0.1uF 20%	50V
FL801	1-518-749-21	INDICATOR TUBE, FLUORESCENT		C445	1-164-732-11	CERAMIC 0.1uF 20%	50V
		< IC >		C446	1-107-611-11	CERAMIC 91PF 5%	500V
IC801	8-759-829-13	IC MSM9202-06GS-BK		C447	1-136-850-11	MYLAR 0.1uF 5%	63V
IC802	8-759-827-70	IC NJL64H400A-1		C448	1-119-824-31	ELECT 10uF 20%	50V
IC803	8-753-206-42	IC CXP84120-092Q				< CONNECTOR >	
		< TRANSISTOR >		CN441	1-506-468-11	PIN, CONNECTOR 3P	
Q801	8-729-027-43	TRANSISTOR DTC114EKA-T146				< IC >	
Q802	8-729-027-43	TRANSISTOR DTC114EKA-T146		IC441	8-759-591-61	IC TC7WHU04FU (TE12R)	
Q803	8-729-027-43	TRANSISTOR DTC114EKA-T146		IC442	6-600-005-01	IC GP1FA351TZ (DIGITAL (CD) OUT, OPTICAL)	
Q810	8-729-027-23	TRANSISTOR DTA114EKA-T146				< JACK >	
Q811	8-729-027-23	TRANSISTOR DTA114EKA-T146		J391	1-770-905-21	JACK, PIN 1P (DIGITAL (CD) OUT, COAXIAL)	
Q812	8-729-027-23	TRANSISTOR DTA114EKA-T146				< RESISTOR >	
		< RESISTOR >		R441	1-216-033-00	RES-CHIP 220 5%	1/10W
R801	1-216-827-11	METAL CHIP 3.3K 5%	1/10W	R442	1-216-022-00	RES-CHIP 75 5%	1/10W
R806	1-216-845-11	METAL CHIP 100K 5%	1/10W			< COIL >	
R807	1-216-845-11	METAL CHIP 100K 5%	1/10W	T441	1-416-701-11	COIL (WITH CORE)	
R808	1-216-845-11	METAL CHIP 100K 5%	1/10W			*****	
R842	1-216-809-11	METAL CHIP 100 5%	1/10W				

SCD-XA9000ES

Ver 1.2



Ref. No.	Part No.	Description	Remark
	A-4747-507-A	D-POWER BOARD, COMPLETE (AEP)	
	A-4747-599-A	D-POWER BOARD, COMPLETE (EXCEPT AEP)	*****
	2-259-121-01	SCREW, TR	
		< CAPACITOR >	
C451	1-130-973-00	MYLAR 0.022uF 5%	100V
C452	1-130-973-00	MYLAR 0.022uF 5%	100V
C453	1-130-973-00	MYLAR 0.022uF 5%	100V
C454	1-130-973-00	MYLAR 0.022uF 5%	100V
C455	1-128-562-11	ELECT 47uF 20%	100V
C456	1-165-319-11	CERAMIC CHIP 0.1uF	50V
C457	1-128-562-11	ELECT 47uF 20%	100V
C458	1-165-319-11	CERAMIC CHIP 0.1uF	50V
C459	1-136-850-11	MYLAR 0.1uF 5%	63V
C460	1-136-850-11	MYLAR 0.1uF 5%	63V
C461	1-135-748-11	ELECT 4700uF	35V
C463	1-135-698-11	ELECT 10000uF	16V
C467	1-136-850-11	MYLAR 0.1uF 5%	63V
C469	1-135-748-11	ELECT 4700uF	35V
		< CONNECTOR >	
CN451	1-691-768-11	PLUG (MICRO CONNECTOR) 6P	
CN453	1-568-955-11	PIN, CONNECTOR 6P	
CN456	1-564-505-11	PLUG, CONNECTOR 2P	
CN457	1-564-505-21	PLUG, CONNECTOR 2P	
		< DIODE >	
D421	8-719-083-52	DIODE UDZSTE-1716B	
D422	8-719-083-58	DIODE UDZSTE-173.9B	
D423	8-719-083-67	DIODE UDZSTE-1720B	
D451	8-719-210-33	DIODE EC10DS2	
D452	8-719-210-33	DIODE EC10DS2	
D453	8-719-210-33	DIODE EC10DS2	
D454	8-719-210-33	DIODE EC10DS2	
D455	8-719-210-33	DIODE EC10DS2	
D456	8-719-210-33	DIODE EC10DS2	
D457	8-719-210-33	DIODE EC10DS2	
D458	8-719-210-33	DIODE EC10DS2	
		< RESISTER >	
△FR451	1-212-877-11	FUSIBLE 68 5%	1/4W
		< IC >	
IC451	8-759-394-35	IC BA12T	
		< COIL >	
L451	1-412-473-51	INDUCTOR (SMALL TYPE)	
L452	1-412-473-51	INDUCTOR (SMALL TYPE)	
L453	1-424-122-11	FILTER, NOISE	
L454	1-424-122-11	FILTER, NOISE	
L455	1-424-122-11	FILTER, NOISE	
L456	1-424-122-11	FILTER, NOISE	
L461	1-424-122-11	FILTER, NOISE	
L462	1-424-122-11	FILTER, NOISE	

Ref. No.	Part No.	Description	Remark
		< TRANSISTOR >	
Q451	8-729-209-71	TRANSISTOR 2SA12130-TE12L	
		< RESISTOR >	
R451	1-216-081-00	RES-CHIP 22K 5%	1/10W
R452	1-216-105-00	RES-CHIP 220K 5%	1/10W
R453	1-216-079-00	RES-CHIP 18K 5%	1/10W
R454	1-216-025-11	RES-CHIP 100 5%	1/10W
R455	1-216-025-11	RES-CHIP 100 5%	1/10W
R456	1-216-073-00	RES-CHIP 10K 5%	1/10W
R461	1-216-061-00	RES-CHIP 3.3K 5%	1/10W
R462	1-216-081-00	RES-CHIP 22K 5%	1/10W
R463	1-216-013-00	RES-CHIP 33 5%	1/10W
		< THERMISTOR (POSITIVE) >	
THP450	1-801-578-11	THERMISTOR, POSITIVE	*****
	1-689-072-11	HP BOARD	*****
		< CAPACITOR >	
C601	1-162-964-11	CERAMIC CHIP 0.001uF 10%	50V
C603	1-162-964-11	CERAMIC CHIP 0.001uF 10%	50V
C604	1-164-227-11	CERAMIC CHIP 0.022uF 10%	25V
		< CONNECTOR >	
* CN601	1-506-468-11	PIN, CONNECTOR 3P	
		< JACK >	
J601	1-770-904-11	JACK (LARGE TYPE) (PHONES)	
		< COIL/SHORT >	
L601	1-424-122-11	FILTER, NOISE	
L602	1-424-122-11	FILTER, NOISE	
L603	1-424-122-11	FILTER, NOISE	
L605	1-216-864-11	SHORT CHIP 0	
L606	1-216-864-11	SHORT CHIP 0	
L607	1-216-864-11	SHORT CHIP 0	
L608	1-414-180-11	MICRO INDUCTOR 3.3uH	
L609	1-414-180-11	MICRO INDUCTOR 3.3uH	
L610	1-414-180-11	MICRO INDUCTOR 3.3uH	
		< VARIABLE RESISTOR >	
RV601	1-227-185-11	RES, VAR, CARBON 1K/1K (PHONE LEVEL)	*****
	1-860-271-21	IC BOARD	*****
		< CAPACITOR >	
C426	1-128-196-91	ELECT 4.7uF 20%	63V
C427	1-128-196-91	ELECT 4.7uF 20%	63V
		< CONNECTOR >	
CN423	1-564-506-11	PLUG, CONNECTOR 3P	

The components identified by mark △ or dotted line with mark △ are critical for safety. Replace only with part number specified.	Les composants identifiés par une marque △ sont critiques pour la sécurité. Ne les remplacer que par une pièce portant le numéro spécifié.
--	--

IC	JOG	KEY-A	KEY-B	LINK
----	-----	-------	-------	------

Ref. No.	Part No.	Description	Remark	Ref. No.	Part No.	Description	Remark
		< IC >		R822	1-216-825-11	METAL CHIP 2.2K 5%	1/10W
IC420	8-759-445-59	IC BA033T		R823	1-216-829-11	METAL CHIP 4.7K 5%	1/10W
*****						< SWITCH >	
	1-689-070-11	JOG BOARD *****		S810	1-762-875-21	SWITCH, KEYBOARD (MULTI/2CH)	
		< CONNECTOR >		S811	1-762-875-21	SWITCH, KEYBOARD (MENU)	
CN806	1-506-469-11	PIN, CONNECTOR 4P		S812	1-762-875-21	SWITCH, KEYBOARD (TIME/TEXT)	
		< SWITCH >		S813	1-762-875-21	SWITCH, KEYBOARD (SACD/CD)	
S830	1-475-543-11	ENCODER, ROTARY (◀◀ ANS ▶▶▶, PUSH ENTER)		S814	1-762-875-21	SWITCH, KEYBOARD (i. LINK)	
*****				*****			
		< CAPACITOR >		A-1143-923-A LINK BOARD, COMPLETE (for SERVICE) *****			
	1-689-068-11	KEY-A BOARD *****		C1901	1-162-915-11	CERAMIC CHIP 10PF 0.5PF 50V	
		< CONNECTOR >		C1902	1-162-915-11	CERAMIC CHIP 10PF 0.5PF 50V	
* CN804	1-568-943-11	PIN, CONNECTOR 5P		C1903	1-162-957-11	CERAMIC CHIP 220PF 5% 50V	
		< LED >		C1904	1-162-921-11	CERAMIC CHIP 33PF 5% 50V	
D801	8-719-046-41	LED SEL5521C-TP15 (▶)		C1905	1-164-156-11	CERAMIC CHIP 0.1uF 25V	
D802	8-719-046-39	LED SEL5821A-TP15 (■)		C1906	1-164-156-11	CERAMIC CHIP 0.1uF 25V	
		< RESISTOR >		C1907	1-164-156-11	CERAMIC CHIP 0.1uF 25V	
R810	1-216-821-11	METAL CHIP 1K 5%	1/10W	C1908	1-164-156-11	CERAMIC CHIP 0.1uF 25V	
R811	1-216-825-11	METAL CHIP 2.2K 5%	1/10W	C1909	1-126-246-11	ELECT CHIP 220uF 20% 4V	
R812	1-216-825-11	METAL CHIP 2.2K 5%	1/10W	C1910	1-115-156-11	CERAMIC CHIP 1uF 10V	
R813	1-216-829-11	METAL CHIP 4.7K 5%	1/10W	C1911	1-164-156-11	CERAMIC CHIP 0.1uF 25V	
R861	1-216-809-11	METAL CHIP 100 5%	1/10W	C1912	1-115-156-11	CERAMIC CHIP 1uF 10V	
R862	1-216-809-11	METAL CHIP 100 5%	1/10W	C1914	1-162-958-11	CERAMIC CHIP 270PF 5% 50V	
		< SWITCH >		C1916	1-164-156-11	CERAMIC CHIP 0.1uF 25V	
S803	1-762-875-21	SWITCH, KEYBOARD (⊕)		C1917	1-164-156-11	CERAMIC CHIP 0.1uF 25V	
S804	1-762-875-21	SWITCH, KEYBOARD (▶)		C1918	1-164-156-11	CERAMIC CHIP 0.1uF 25V	
S805	1-762-875-21	SWITCH, KEYBOARD (■)		C1919	1-164-156-11	CERAMIC CHIP 0.1uF 25V	
S806	1-762-875-21	SWITCH, KEYBOARD (■)		C1920	1-164-156-11	CERAMIC CHIP 0.1uF 25V	
*****				C1921	1-164-156-11	CERAMIC CHIP 0.1uF 25V	
	1-689-069-11	KEY-B BOARD *****		C1922	1-126-246-11	ELECT CHIP 220uF 20% 4V	
		< CAPACITOR >		C1923	1-164-156-11	CERAMIC CHIP 0.1uF 25V	
C820	1-131-992-91	CERAMIC CHIP 100000PF	35V	C1924	1-164-156-11	CERAMIC CHIP 0.1uF 25V	
		< CONNECTOR >		C1925	1-164-156-11	CERAMIC CHIP 0.1uF 25V	
* CN812	1-568-941-11	PIN, CONNECTOR 3P		C1926	1-164-156-11	CERAMIC CHIP 0.1uF 25V	
		< LED >		C1927	1-164-156-11	CERAMIC CHIP 0.1uF 25V	
D803	8-719-084-07	LED SEL5E20CTP15 (i. LINK)		C1928	1-164-156-11	CERAMIC CHIP 0.1uF 25V	
		< RESISTOR >		C1929	1-164-156-11	CERAMIC CHIP 0.1uF 25V	
R818	1-216-807-11	METAL CHIP 68 5%	1/10W	C1930	1-164-156-11	CERAMIC CHIP 0.1uF 25V	
R819	1-216-833-11	METAL CHIP 10K 5%	1/10W	C1931	1-164-156-11	CERAMIC CHIP 0.1uF 25V	
R820	1-216-821-11	METAL CHIP 1K 5%	1/10W	C1932	1-164-156-11	CERAMIC CHIP 0.1uF 25V	
R821	1-216-825-11	METAL CHIP 2.2K 5%	1/10W	C1933	1-164-156-11	CERAMIC CHIP 0.1uF 25V	
				C1934	1-164-156-11	CERAMIC CHIP 0.1uF 25V	
				C1935	1-164-156-11	CERAMIC CHIP 0.1uF 25V	
				C1936	1-164-156-11	CERAMIC CHIP 0.1uF 25V	
				C1937	1-164-156-11	CERAMIC CHIP 0.1uF 25V	
				C1938	1-164-156-11	CERAMIC CHIP 0.1uF 25V	
				C1939	1-164-156-11	CERAMIC CHIP 0.1uF 25V	
				C1940	1-125-822-11	TANTALUM CHIP 10uF 20% 10V	
				C1941	1-164-156-11	CERAMIC CHIP 0.1uF 25V	
				C1943	1-164-156-11	CERAMIC CHIP 0.1uF 25V	
				C1944	1-164-156-11	CERAMIC CHIP 0.1uF 25V	
				C1945	1-164-156-11	CERAMIC CHIP 0.1uF 25V	
				C1946	1-164-156-11	CERAMIC CHIP 0.1uF 25V	

SCD-XA9000ES

Ver. 1.4

LINK

Ref. No.	Part No.	Description	Remark	Ref. No.	Part No.	Description	Remark
C1947	1-164-156-11	CERAMIC CHIP 0.1uF	25V			< TRANSISTOR >	
C1948	1-125-822-11	TANTALUM CHIP 10uF	20% 10V				
C1949	1-126-246-11	ELECT CHIP 220uF	20% 4V	Q1901	8-729-422-35	TRANSISTOR 2SD601A-S-TX	
C1950	1-164-156-11	CERAMIC CHIP 0.1uF	25V	Q1902	8-729-422-35	TRANSISTOR 2SD601A-S-TX	
C1951	1-164-156-11	CERAMIC CHIP 0.1uF	25V	Q1903	8-729-422-35	TRANSISTOR 2SD601A-S-TX	
C1952	1-125-822-11	TANTALUM CHIP 10uF	20% 10V	Q1904	8-729-901-47	TRANSISTOR DTA143EK	
C1953	1-164-156-11	CERAMIC CHIP 0.1uF	25V			< RESISTOR >	
C1954	1-115-156-11	CERAMIC CHIP 1uF	10V	R1801	1-216-833-11	METAL CHIP 10K 5%	1/10W
C1957	1-125-822-11	TANTALUM CHIP 10uF	20% 10V	R1802	1-216-833-11	METAL CHIP 10K 5%	1/10W
C1959	1-126-246-11	ELECT CHIP 220uF	20% 4V	R1803	1-216-833-11	METAL CHIP 10K 5%	1/10W
C1960	1-162-915-11	CERAMIC CHIP 10PF	0.5PF 50V	R1804	1-216-829-11	METAL CHIP 4.7K 5%	1/10W
C1961	1-162-915-11	CERAMIC CHIP 10PF	0.5PF 50V	R1805	1-216-829-11	METAL CHIP 4.7K 5%	1/10W
		< CONNECTOR >		R1806	1-216-829-11	METAL CHIP 4.7K 5%	1/10W
CN1901	1-784-875-21	CONNECTOR, FFC (LIF (NON-ZIF)) 25P		R1807	1-216-864-11	SHORT CHIP 0	
CN1902	1-784-688-41	PIN, CONNECTOR (PC BOARD) 2P		R1808	1-216-864-11	SHORT CHIP 0	
CN1903	1-784-369-21	CONNECTOR, FFC/FPC 10P		R1809	1-216-864-11	SHORT CHIP 0	
		< DIODE >		R1810	1-216-864-11	SHORT CHIP 0	
D1901	8-719-058-24	DIODE RB501V-40TE-17		R1811	1-216-864-11	SHORT CHIP 0	
D1903	8-719-058-24	DIODE RB501V-40TE-17		R1812	1-216-864-11	SHORT CHIP 0	
		< FERRITE BEAD >		R1813	1-216-864-11	SHORT CHIP 0	
FB1901	1-469-835-21	INDUCTOR, FERRITE BEAD		R1814	1-216-864-11	SHORT CHIP 0	
FB1902	1-469-835-21	INDUCTOR, FERRITE BEAD		R1815	1-216-864-11	SHORT CHIP 0	
FB1903	1-500-283-11	INDUCTOR, FERRITE BEAD		R1816	1-216-864-11	SHORT CHIP 0	
FB1904	1-469-835-21	INDUCTOR, FERRITE BEAD		R1817	1-216-864-11	SHORT CHIP 0	
FB1905	1-500-283-11	INDUCTOR, FERRITE BEAD		R1818	1-216-864-11	SHORT CHIP 0	
FB1906	1-500-283-11	INDUCTOR, FERRITE BEAD		R1819	1-216-864-11	SHORT CHIP 0	
FB1907	1-500-283-11	INDUCTOR, FERRITE BEAD		R1820	1-216-864-11	SHORT CHIP 0	
		< FILTER >		R1821	1-216-864-11	SHORT CHIP 0	
FL1901	1-234-177-21	FILTER, CHIP EMI		R1822	1-216-864-11	SHORT CHIP 0	
FL1902	1-234-177-21	FILTER, CHIP EMI		R1823	1-216-864-11	SHORT CHIP 0	
FL1903	1-234-177-21	FILTER, CHIP EMI		R1897	1-216-829-11	METAL CHIP 4.7K 5%	1/10W
FL1904	1-234-177-21	FILTER, CHIP EMI		R1898	1-216-829-11	METAL CHIP 4.7K 5%	1/10W
FL1905	1-234-177-21	FILTER, CHIP EMI		R1899	1-216-833-11	METAL CHIP 10K 5%	1/10W
FL1906	1-234-177-21	FILTER, CHIP EMI		R1901	1-216-833-11	METAL CHIP 10K 5%	1/10W
		< IC >		R1902	1-216-833-11	METAL CHIP 10K 5%	1/10W
IC1901	8-752-421-58	IC CXD3210AR		R1903	1-216-833-11	METAL CHIP 10K 5%	1/10W
IC1902	6-704-169-01	IC TMS320VC5409PGE100A		R1904	1-216-833-11	METAL CHIP 10K 5%	1/10W
IC1903	(Not supplied)	IC M30626FHFPF-SCD-XA9000		R1905	1-216-833-11	METAL CHIP 10K 5%	1/10W
IC1904	(Not supplied)	IC AT28BV64B-25SI		R1906	1-216-833-11	METAL CHIP 10K 5%	1/10W
IC1905	8-759-832-05	IC BA18BC0FP-E2		R1907	1-218-867-11	METAL CHIP 6.8K 0.5%	1/10W
IC1906	6-700-852-01	IC SI-3018LUS-TP		R1908	1-216-845-11	METAL CHIP 100K 5%	1/10W
IC1907	8-759-649-46	IC SN74AHC1G08DCKR		R1909	1-216-829-11	METAL CHIP 4.7K 5%	1/10W
		< JACK >		R1910	1-216-829-11	METAL CHIP 4.7K 5%	1/10W
J1901	1-793-078-11	CONNECTOR, SQUARE TYPE 4P		R1911	1-216-833-11	METAL CHIP 10K 5%	1/10W
		< COIL >		R1912	1-216-833-11	METAL CHIP 10K 5%	1/10W
L1901	1-400-098-21	COIL, COMMON MODE CHOKE		R1913	1-216-857-11	METAL CHIP 1M 5%	1/10W
L1903	1-400-098-21	COIL, COMMON MODE CHOKE		R1915	1-208-359-81	RES-CHIP 56 0.5%	1/10W
				R1916	1-208-359-81	RES-CHIP 56 0.5%	1/10W
				R1918	1-216-295-00	SHORT CHIP 0	
				R1919	1-208-359-81	RES-CHIP 56 0.5%	1/10W
				R1920	1-208-359-81	RES-CHIP 56 0.5%	1/10W
				R1921	1-216-833-11	METAL CHIP 10K 5%	1/10W
				R1923	1-216-295-00	SHORT CHIP 0	
				R1924	1-216-864-11	SHORT CHIP 0	
				R1925	1-216-833-11	METAL CHIP 10K 5%	1/10W
				R1926	1-216-833-11	METAL CHIP 10K 5%	1/10W
				R1927	1-216-833-11	METAL CHIP 10K 5%	1/10W

LINK

LOADING MOTOR

MAIN

Ref. No.	Part No.	Description	Remark	Ref. No.	Part No.	Description	Remark
R1928	1-216-833-11	METAL CHIP	10K 5% 1/10W	R1988	1-216-833-11	METAL CHIP	10K 5% 1/10W
R1929	1-216-833-11	METAL CHIP	10K 5% 1/10W	R1989	1-216-864-11	SHORT CHIP	0
R1930	1-216-833-11	METAL CHIP	10K 5% 1/10W	R1990	1-216-864-11	SHORT CHIP	0
R1931	1-216-833-11	METAL CHIP	10K 5% 1/10W	R1991	1-216-864-11	SHORT CHIP	0
R1932	1-216-833-11	METAL CHIP	10K 5% 1/10W	R1992	1-216-833-11	METAL CHIP	10K 5% 1/10W
R1933	1-216-833-11	METAL CHIP	10K 5% 1/10W	R1994	1-216-833-11	METAL CHIP	10K 5% 1/10W
R1934	1-216-833-11	METAL CHIP	10K 5% 1/10W	R1995	1-216-833-11	METAL CHIP	10K 5% 1/10W
R1935	1-216-833-11	METAL CHIP	10K 5% 1/10W	R1996	1-216-833-11	METAL CHIP	10K 5% 1/10W
R1936	1-216-833-11	METAL CHIP	10K 5% 1/10W	R1997	1-216-833-11	METAL CHIP	10K 5% 1/10W
R1938	1-216-833-11	METAL CHIP	10K 5% 1/10W	R1998	1-216-833-11	METAL CHIP	10K 5% 1/10W
R1939	1-216-833-11	METAL CHIP	10K 5% 1/10W	R1999	1-216-833-11	METAL CHIP	10K 5% 1/10W
R1940	1-216-833-11	METAL CHIP	10K 5% 1/10W			< VIBRATOR >	
R1941	1-216-833-11	METAL CHIP	10K 5% 1/10W	X1901	1-795-219-21	VIBRATOR, CRYSTAL (24.576MHZ)	
R1942	1-216-833-11	METAL CHIP	10K 5% 1/10W	X1902	1-795-244-11	VIBRATOR, CERAMIC (10MHZ)	
R1943	1-216-833-11	METAL CHIP	10K 5% 1/10W	X1903	1-579-996-21	VIBRATOR, CERAMIC (20MHZ)	
R1944	1-216-833-11	METAL CHIP	10K 5% 1/10W	*****			
R1945	1-216-833-11	METAL CHIP	10K 5% 1/10W	*	1-641-765-13	LOADING MOTOR BOARD	*****
R1946	1-216-833-11	METAL CHIP	10K 5% 1/10W	*****			
R1947	1-216-833-11	METAL CHIP	10K 5% 1/10W		A-4747-512-A	MAIN BOARD, COMPLETE	*****
R1948	1-216-833-11	METAL CHIP	10K 5% 1/10W	< CAPACITOR >			
R1949	1-216-833-11	METAL CHIP	10K 5% 1/10W	C501	1-125-837-11	CERAMIC CHIP	1uF 10% 6.3V
R1950	1-216-833-11	METAL CHIP	10K 5% 1/10W	C502	1-107-826-11	CERAMIC CHIP	0.1uF 10% 16V
R1951	1-216-833-11	METAL CHIP	10K 5% 1/10W	C506	1-107-826-11	CERAMIC CHIP	0.1uF 10% 16V
R1952	1-216-833-11	METAL CHIP	10K 5% 1/10W	C509	1-107-826-11	CERAMIC CHIP	0.1uF 10% 16V
R1953	1-216-833-11	METAL CHIP	10K 5% 1/10W	C510	1-107-826-11	CERAMIC CHIP	0.1uF 10% 16V
R1954	1-216-833-11	METAL CHIP	10K 5% 1/10W	C511	1-107-826-11	CERAMIC CHIP	0.1uF 10% 16V
R1955	1-216-833-11	METAL CHIP	10K 5% 1/10W	C513	1-107-826-11	CERAMIC CHIP	0.1uF 10% 16V
R1956	1-216-833-11	METAL CHIP	10K 5% 1/10W	C516	1-107-826-11	CERAMIC CHIP	0.1uF 10% 16V
R1957	1-216-833-11	METAL CHIP	10K 5% 1/10W	C517	1-125-822-11	TANTALUM CHIP	10uF 20% 10V
R1958	1-216-833-11	METAL CHIP	10K 5% 1/10W	C518	1-107-826-11	CERAMIC CHIP	0.1uF 10% 16V
R1959	1-216-864-11	SHORT CHIP	0	C519	1-125-837-11	CERAMIC CHIP	1uF 10% 6.3V
R1960	1-216-833-11	METAL CHIP	10K 5% 1/10W	C520	1-126-395-11	ELECT CHIP	22uF 20% 16V
R1961	1-216-833-11	METAL CHIP	10K 5% 1/10W	C521	1-162-965-11	CERAMIC CHIP	0.0015uF 10% 50V
R1962	1-216-833-11	METAL CHIP	10K 5% 1/10W	C523	1-162-965-11	CERAMIC CHIP	0.0015uF 10% 50V
R1963	1-216-833-11	METAL CHIP	10K 5% 1/10W	C525	1-107-826-11	CERAMIC CHIP	0.1uF 10% 16V
R1964	1-216-864-11	SHORT CHIP	0	C526	1-107-826-11	CERAMIC CHIP	0.1uF 10% 16V
R1965	1-216-833-11	METAL CHIP	10K 5% 1/10W	C527	1-164-739-11	CERAMIC CHIP	560PF 5% 50V
R1966	1-216-833-11	METAL CHIP	10K 5% 1/10W	C528	1-125-822-11	TANTALUM CHIP	10uF 20% 10V
R1967	1-216-825-11	METAL CHIP	2.2K 5% 1/10W	C529	1-164-739-11	CERAMIC CHIP	560PF 5% 50V
R1968	1-216-833-11	METAL CHIP	10K 5% 1/10W	C530	1-107-826-11	CERAMIC CHIP	0.1uF 10% 16V
R1970	1-216-833-11	METAL CHIP	10K 5% 1/10W	C531	1-165-176-11	CERAMIC CHIP	0.047uF 10% 16V
R1971	1-216-833-11	METAL CHIP	10K 5% 1/10W	C532	1-107-826-11	CERAMIC CHIP	0.1uF 10% 16V
R1972	1-216-833-11	METAL CHIP	10K 5% 1/10W	C533	1-162-966-11	CERAMIC CHIP	0.0022uF 10% 50V
R1973	1-216-829-11	METAL CHIP	4.7K 5% 1/10W	C534	1-164-227-11	CERAMIC CHIP	0.022uF 10% 25V
R1974	1-216-833-11	METAL CHIP	10K 5% 1/10W	C535	1-162-966-11	CERAMIC CHIP	0.0022uF 10% 50V
R1975	1-216-833-11	METAL CHIP	10K 5% 1/10W	C536	1-125-891-11	CERAMIC CHIP	0.47uF 10% 10V
R1976	1-216-833-11	METAL CHIP	10K 5% 1/10W	C539	1-107-826-11	CERAMIC CHIP	0.1uF 10% 16V
R1977	1-216-864-11	SHORT CHIP	0	C541	1-107-826-11	CERAMIC CHIP	0.1uF 10% 16V
R1978	1-216-857-11	METAL CHIP	1M 5% 1/10W	C542	1-125-891-11	CERAMIC CHIP	0.47uF 10% 10V
R1979	1-216-833-11	METAL CHIP	10K 5% 1/10W	C543	1-107-826-11	CERAMIC CHIP	0.1uF 10% 16V
R1980	1-216-833-11	METAL CHIP	10K 5% 1/10W	C544	1-107-826-11	CERAMIC CHIP	0.1uF 10% 16V
R1981	1-216-833-11	METAL CHIP	10K 5% 1/10W	C545	1-125-822-11	TANTALUM CHIP	10uF 20% 10V
R1982	1-216-833-11	METAL CHIP	10K 5% 1/10W				
R1983	1-216-833-11	METAL CHIP	10K 5% 1/10W				
R1984	1-216-833-11	METAL CHIP	10K 5% 1/10W				
R1985	1-216-833-11	METAL CHIP	10K 5% 1/10W				
R1986	1-216-817-11	METAL CHIP	470 5% 1/10W				
R1987	1-216-833-11	METAL CHIP	10K 5% 1/10W				

SCD-XA9000ES

MAIN

Ref. No.	Part No.	Description			Remark	Ref. No.	Part No.	Description			Remark
C547	1-107-826-11	CERAMIC CHIP	0.1uF	10%	16V	C730	1-164-156-11	CERAMIC CHIP	0.1uF		25V
C548	1-162-970-11	CERAMIC CHIP	0.01uF	10%	25V	C731	1-107-826-11	CERAMIC CHIP	0.1uF	10%	16V
C549	1-107-826-11	CERAMIC CHIP	0.1uF	10%	16V	C740	1-164-156-11	CERAMIC CHIP	0.1uF		25V
C550	1-115-412-11	CERAMIC CHIP	680PF	5%	25V	C741	1-164-156-11	CERAMIC CHIP	0.1uF		25V
C551	1-125-891-11	CERAMIC CHIP	0.47uF	10%	10V	C742	1-164-156-11	CERAMIC CHIP	0.1uF		25V
C553	1-162-970-11	CERAMIC CHIP	0.01uF	10%	25V	C743	1-164-156-11	CERAMIC CHIP	0.1uF		25V
C554	1-107-826-11	CERAMIC CHIP	0.1uF	10%	16V	C744	1-164-156-11	CERAMIC CHIP	0.1uF		25V
C555	1-115-412-11	CERAMIC CHIP	680PF	5%	25V	C745	1-164-156-11	CERAMIC CHIP	0.1uF		25V
C556	1-125-822-11	TANTALUM CHIP	10uF	20%	10V	C746	1-115-467-11	CERAMIC CHIP	0.22uF	10%	10V
C558	1-115-412-11	CERAMIC CHIP	680PF	5%	25V	C747	1-125-837-11	CERAMIC CHIP	1uF	10%	6.3V
C559	1-107-826-11	CERAMIC CHIP	0.1uF	10%	16V	C752	1-164-156-11	CERAMIC CHIP	0.1uF		25V
C560	1-162-965-11	CERAMIC CHIP	0.0015uF	10%	50V	C760	1-164-156-11	CERAMIC CHIP	0.1uF		25V
C561	1-107-826-11	CERAMIC CHIP	0.1uF	10%	16V	C761	1-164-156-11	CERAMIC CHIP	0.1uF		25V
C562	1-115-412-11	CERAMIC CHIP	680PF	5%	25V	C762	1-164-156-11	CERAMIC CHIP	0.1uF		25V
C563	1-162-927-11	CERAMIC CHIP	100PF	5%	50V	C763	1-164-156-11	CERAMIC CHIP	0.1uF		25V
C565	1-107-826-11	CERAMIC CHIP	0.1uF	10%	16V	C764	1-164-156-11	CERAMIC CHIP	0.1uF		25V
C567	1-107-826-11	CERAMIC CHIP	0.1uF	10%	16V	C765	1-164-156-11	CERAMIC CHIP	0.1uF		25V
C568	1-125-822-11	TANTALUM CHIP	10uF	20%	10V	C766	1-162-927-11	CERAMIC CHIP	100PF	5%	50V
C569	1-107-826-11	CERAMIC CHIP	0.1uF	10%	16V	C767	1-164-156-11	CERAMIC CHIP	0.1uF		25V
C570	1-125-822-11	TANTALUM CHIP	10uF	20%	10V	C768	1-164-156-11	CERAMIC CHIP	0.1uF		25V
C572	1-125-837-11	CERAMIC CHIP	1uF	10%	6.3V	C769	1-164-156-11	CERAMIC CHIP	0.1uF		25V
C577	1-162-970-11	CERAMIC CHIP	0.01uF	10%	25V	C770	1-164-156-11	CERAMIC CHIP	0.1uF		25V
C579	1-107-826-11	CERAMIC CHIP	0.1uF	10%	16V	C771	1-165-176-11	CERAMIC CHIP	0.047uF	10%	16V
C582	1-107-826-11	CERAMIC CHIP	0.1uF	10%	16V	C772	1-164-156-11	CERAMIC CHIP	0.1uF		25V
C583	1-107-826-11	CERAMIC CHIP	0.1uF	10%	16V	C773	1-125-891-11	CERAMIC CHIP	0.47uF	10%	10V
C584	1-126-395-11	ELECT CHIP	22uF	20%	16V	C774	1-162-968-11	CERAMIC CHIP	0.0047uF	10%	50V
C587	1-107-826-11	CERAMIC CHIP	0.1uF	10%	16V	C775	1-164-156-11	CERAMIC CHIP	0.1uF		25V
C588	1-162-966-11	CERAMIC CHIP	0.0022uF	10%	50V	C776	1-164-156-11	CERAMIC CHIP	0.1uF		25V
C589	1-162-966-11	CERAMIC CHIP	0.0022uF	10%	50V	C777	1-164-156-11	CERAMIC CHIP	0.1uF		25V
C590	1-162-964-11	CERAMIC CHIP	0.001uF	10%	50V	C778	1-164-156-11	CERAMIC CHIP	0.1uF		25V
C591	1-125-822-11	TANTALUM CHIP	10uF	20%	10V	C779	1-125-822-11	TANTALUM CHIP	10uF	20%	10V
C592	1-125-822-11	TANTALUM CHIP	10uF	20%	10V	C780	1-125-822-11	TANTALUM CHIP	10uF	20%	10V
C701	1-125-822-11	TANTALUM CHIP	10uF	20%	10V	C781	1-125-822-11	TANTALUM CHIP	10uF	20%	10V
C702	1-125-822-11	TANTALUM CHIP	10uF	20%	10V	C790	1-126-204-11	ELECT CHIP	47uF	20%	16V
C703	1-125-837-11	CERAMIC CHIP	1uF	10%	6.3V	C791	1-126-206-11	ELECT CHIP	100uF	20%	6.3V
C704	1-125-837-11	CERAMIC CHIP	1uF	10%	6.3V	C792	1-126-206-11	ELECT CHIP	100uF	20%	6.3V
C705	1-164-156-11	CERAMIC CHIP	0.1uF		25V	C793	1-126-246-11	ELECT CHIP	220uF	20%	4V
C706	1-164-156-11	CERAMIC CHIP	0.1uF		25V	C794	1-126-246-11	ELECT CHIP	220uF	20%	4V
C708	1-162-970-11	CERAMIC CHIP	0.01uF	10%	25V	C795	1-126-206-11	ELECT CHIP	100uF	20%	6.3V
C709	1-164-156-11	CERAMIC CHIP	0.1uF		25V	C796	1-125-837-11	CERAMIC CHIP	1uF	10%	6.3V
C711	1-162-970-11	CERAMIC CHIP	0.01uF	10%	25V	C797	1-126-246-11	ELECT CHIP	220uF	20%	4V
C712	1-164-816-11	CERAMIC CHIP	220PF	2%	50V	C798	1-164-156-11	CERAMIC CHIP	0.1uF		25V
C713	1-164-156-11	CERAMIC CHIP	0.1uF		25V	C800	1-162-970-11	CERAMIC CHIP	0.01uF	10%	25V
C714	1-125-837-11	CERAMIC CHIP	1uF	10%	6.3V	C802	1-125-822-11	TANTALUM CHIP	10uF	20%	10V
C715	1-162-965-11	CERAMIC CHIP	0.0015uF	10%	50V	C803	1-162-970-11	CERAMIC CHIP	0.01uF	10%	25V
C716	1-125-891-11	CERAMIC CHIP	0.47uF	10%	10V	C804	1-162-970-11	CERAMIC CHIP	0.01uF	10%	25V
C717	1-162-970-11	CERAMIC CHIP	0.01uF	10%	25V	C807	1-162-970-11	CERAMIC CHIP	0.01uF	10%	25V
C718	1-164-156-11	CERAMIC CHIP	0.1uF		25V	C808	1-162-927-11	CERAMIC CHIP	100PF	5%	50V
C720	1-107-826-11	CERAMIC CHIP	0.1uF	10%	16V	C809	1-125-822-11	TANTALUM CHIP	10uF	20%	10V
C721	1-125-837-11	CERAMIC CHIP	1uF	10%	6.3V	C810	1-162-970-11	CERAMIC CHIP	0.01uF	10%	25V
C722	1-164-156-11	CERAMIC CHIP	0.1uF		25V	C811	1-162-970-11	CERAMIC CHIP	0.01uF	10%	25V
C723	1-164-156-11	CERAMIC CHIP	0.1uF		25V	C812	1-162-970-11	CERAMIC CHIP	0.01uF	10%	25V
C724	1-164-156-11	CERAMIC CHIP	0.1uF		25V	C813	1-162-970-11	CERAMIC CHIP	0.01uF	10%	25V
C725	1-164-156-11	CERAMIC CHIP	0.1uF		25V	C815	1-162-970-11	CERAMIC CHIP	0.01uF	10%	25V
C726	1-164-156-11	CERAMIC CHIP	0.1uF		25V	C817	1-162-970-11	CERAMIC CHIP	0.01uF	10%	25V
C727	1-125-822-11	TANTALUM CHIP	10uF	20%	10V	C818	1-162-970-11	CERAMIC CHIP	0.01uF	10%	25V
C728	1-107-826-11	CERAMIC CHIP	0.1uF	10%	16V	C819	1-162-970-11	CERAMIC CHIP	0.01uF	10%	25V
C729	1-125-822-11	TANTALUM CHIP	10uF	20%	10V						

Ref. No.	Part No.	Description	Remark	Ref. No.	Part No.	Description	Remark	
C820	1-164-156-11	CERAMIC CHIP	0.1uF	25V				
C821	1-162-970-11	CERAMIC CHIP	0.01uF	10%	25V			
C822	1-164-156-11	CERAMIC CHIP	0.1uF	25V				
C823	1-164-156-11	CERAMIC CHIP	0.1uF	25V				
C824	1-164-156-11	CERAMIC CHIP	0.1uF	25V				
C825	1-164-156-11	CERAMIC CHIP	0.1uF	25V				
C826	1-164-156-11	CERAMIC CHIP	0.1uF	25V				
C827	1-164-156-11	CERAMIC CHIP	0.1uF	25V				
C828	1-164-156-11	CERAMIC CHIP	0.1uF	25V				
C829	1-164-156-11	CERAMIC CHIP	0.1uF	25V				
C830	1-164-156-11	CERAMIC CHIP	0.1uF	25V				
C831	1-164-156-11	CERAMIC CHIP	0.1uF	25V				
C832	1-125-822-11	TANTALUM CHIP	10uF	20%	10V			
C837	1-162-970-11	CERAMIC CHIP	0.01uF	10%	25V			
C838	1-162-970-11	CERAMIC CHIP	0.01uF	10%	25V			
C839	1-162-970-11	CERAMIC CHIP	0.01uF	10%	25V			
C840	1-125-822-11	TANTALUM CHIP	10uF	20%	10V			
C841	1-125-822-11	TANTALUM CHIP	10uF	20%	10V			
C842	1-162-970-11	CERAMIC CHIP	0.01uF	10%	25V			
C843	1-162-970-11	CERAMIC CHIP	0.01uF	10%	25V			
C844	1-164-156-11	CERAMIC CHIP	0.1uF	25V				
C845	1-126-246-11	ELECT CHIP	220uF	20%	4V			
C846	1-126-206-11	ELECT CHIP	100uF	20%	6.3V			
C847	1-164-156-11	CERAMIC CHIP	0.1uF	25V				
C848	1-162-970-11	CERAMIC CHIP	0.01uF	10%	25V			
C849	1-162-970-11	CERAMIC CHIP	0.01uF	10%	25V			
C850	1-162-945-11	CERAMIC CHIP	22PF	5%	50V			
C851	1-162-945-11	CERAMIC CHIP	22PF	5%	50V			
C852	1-162-945-11	CERAMIC CHIP	22PF	5%	50V			
C854	1-162-970-11	CERAMIC CHIP	0.01uF	10%	25V			
C855	1-162-970-11	CERAMIC CHIP	0.01uF	10%	25V			
C856	1-162-970-11	CERAMIC CHIP	0.01uF	10%	25V			
C857	1-162-970-11	CERAMIC CHIP	0.01uF	10%	25V			
C858	1-126-206-11	ELECT CHIP	100uF	20%	6.3V			
C860	1-162-970-11	CERAMIC CHIP	0.01uF	10%	25V			
C861	1-162-970-11	CERAMIC CHIP	0.01uF	10%	25V			
C865	1-162-970-11	CERAMIC CHIP	0.01uF	10%	25V			
C866	1-162-970-11	CERAMIC CHIP	0.01uF	10%	25V			
C867	1-162-970-11	CERAMIC CHIP	0.01uF	10%	25V			
C870	1-164-227-11	CERAMIC CHIP	0.022uF	10%	25V			
C871	1-162-970-11	CERAMIC CHIP	0.01uF	10%	25V			
C882	1-164-156-11	CERAMIC CHIP	0.1uF	25V				
C883	1-162-964-11	CERAMIC CHIP	0.001uF	10%	50V			
C901	1-125-822-11	TANTALUM CHIP	10uF	20%	10V			
C902	1-162-970-11	CERAMIC CHIP	0.01uF	10%	25V			
C903	1-125-822-11	TANTALUM CHIP	10uF	20%	10V			
C904	1-162-970-11	CERAMIC CHIP	0.01uF	10%	25V			
C905	1-162-970-11	CERAMIC CHIP	0.01uF	10%	25V			
C906	1-162-970-11	CERAMIC CHIP	0.01uF	10%	25V			
C907	1-107-826-11	CERAMIC CHIP	0.1uF	10%	16V			
C908	1-162-970-11	CERAMIC CHIP	0.01uF	10%	25V			
C909	1-162-927-11	CERAMIC CHIP	100PF	5%	50V			
C910	1-162-970-11	CERAMIC CHIP	0.01uF	10%	25V			
C911	1-125-822-11	TANTALUM CHIP	10uF	20%	10V			
C912	1-107-826-11	CERAMIC CHIP	0.1uF	10%	16V			
C913	1-164-156-11	CERAMIC CHIP	0.1uF	25V				
C914	1-125-822-11	TANTALUM CHIP	10uF	20%	10V			
C915	1-162-927-11	CERAMIC CHIP	100PF	5%	50V			
C916	1-162-970-11	CERAMIC CHIP	0.01uF	10%	25V			
C917	1-107-826-11	CERAMIC CHIP	0.1uF	10%	16V			
C918	1-107-826-11	CERAMIC CHIP	0.1uF	10%	16V			
C920	1-162-970-11	CERAMIC CHIP	0.01uF	10%	25V			
C921	1-162-970-11	CERAMIC CHIP	0.01uF	10%	25V			
C923	1-125-837-11	CERAMIC CHIP	1uF	10%	6.3V			
C924	1-162-970-11	CERAMIC CHIP	0.01uF	10%	25V			
C925	1-164-156-11	CERAMIC CHIP	0.1uF	25V				
C940	1-164-156-11	CERAMIC CHIP	0.1uF	25V				
C941	1-125-837-11	CERAMIC CHIP	1uF	10%	6.3V			
C942	1-107-826-11	CERAMIC CHIP	0.1uF	10%	16V			
C945	1-107-826-11	CERAMIC CHIP	0.1uF	10%	16V			
C946	1-107-826-11	CERAMIC CHIP	0.1uF	10%	16V			
C951	1-164-156-11	CERAMIC CHIP	0.1uF	25V				
C952	1-164-156-11	CERAMIC CHIP	0.1uF	25V				
C953	1-164-156-11	CERAMIC CHIP	0.1uF	25V				
C954	1-162-927-11	CERAMIC CHIP	100PF	5%	50V			
		< CONNECTOR >						
CN701	1-784-871-21	CONNECTOR, FFC (LIF (NON-ZIF))	19P					
CN702	1-784-871-21	CONNECTOR, FFC (LIF (NON-ZIF))	19P					
CN703	1-784-688-41	PIN, CONNECTOR (PC BOARD)	2P					
CN704	1-774-653-41	PIN, CONNECTOR (PC BOARD)	3P					
CN705	1-691-591-91	PIN, CONNECTOR	8P					
CN706	1-794-708-11	PIN, CONNECTOR (PC BOARD)	7P					
CN707	1-794-606-41	PIN, CONNECTOR (PC BOARD)	9P					
CN708	1-784-883-21	CONNECTOR, FFC (LIF (NON-ZIF))	35P					
CN709	1-573-768-91	PIN, CONNECTOR	5P					
CN710	1-784-875-21	CONNECTOR, FFC (LIF (NON-ZIF))	25P					
		< DIODE >						
D903	8-719-049-09	DIODE 1SS367-T3SONY						
D904	8-719-049-09	DIODE 1SS367-T3SONY						
D905	8-719-049-09	DIODE 1SS367-T3SONY						
		< FERRITE BEAD >						
FB700	1-469-835-21	INDUCTOR, FERRITE BEAD						
FB701	1-469-835-21	INDUCTOR, FERRITE BEAD						
FB703	1-500-283-11	INDUCTOR, FERRITE BEAD						
FB704	1-500-283-11	INDUCTOR, FERRITE BEAD						
FB705	1-469-835-21	INDUCTOR, FERRITE BEAD						
FB706	1-469-835-21	INDUCTOR, FERRITE BEAD						
FB707	1-500-283-11	INDUCTOR, FERRITE BEAD						
FB708	1-500-283-11	INDUCTOR, FERRITE BEAD						
FB709	1-500-283-11	INDUCTOR, FERRITE BEAD						
FB710	1-500-283-11	INDUCTOR, FERRITE BEAD						
FB711	1-500-283-11	INDUCTOR, FERRITE BEAD						
FB712	1-500-283-11	INDUCTOR, FERRITE BEAD						
FB713	1-500-283-11	INDUCTOR, FERRITE BEAD						
FB714	1-500-283-11	INDUCTOR, FERRITE BEAD						
FB715	1-500-283-11	INDUCTOR, FERRITE BEAD						
FB716	1-500-283-11	INDUCTOR, FERRITE BEAD						
FB717	1-500-283-11	INDUCTOR, FERRITE BEAD						
FB718	1-500-283-11	INDUCTOR, FERRITE BEAD						
FB719	1-500-283-11	INDUCTOR, FERRITE BEAD						
FB720	1-500-283-11	INDUCTOR, FERRITE BEAD						
FB721	1-500-283-11	INDUCTOR, FERRITE BEAD						

SCD-XA9000ES

MAIN

Ref. No.	Part No.	Description	Remark	Ref. No.	Part No.	Description	Remark
FB722	1-500-283-11	INDUCTOR, FERRITE BEAD		IC801	8-752-416-77	IC CXD2753R	
FB723	1-500-283-11	INDUCTOR, FERRITE BEAD		IC802	6-702-288-01	IC CXD9722TQ	
FB724	1-500-283-11	INDUCTOR, FERRITE BEAD		IC803	(Not supplied)	IC MSM56V16160F-10T4FM1	
FB725	1-500-283-11	INDUCTOR, FERRITE BEAD		IC804	8-759-549-24	IC SN74LV86APWR	
FB726	1-500-283-11	INDUCTOR, FERRITE BEAD		IC808	(Not supplied)	IC MSM56V16160F-10T4FM1	
FB727	1-500-283-11	INDUCTOR, FERRITE BEAD		IC810	8-759-649-46	IC SN74AHC1G08DCKR	
FB728	1-500-283-11	INDUCTOR, FERRITE BEAD		IC811	8-759-549-25	IC SN74LVU04APWR	
FB751	1-500-283-11	INDUCTOR, FERRITE BEAD		IC812	8-759-549-15	IC SN74LV245APWR	
FB753	1-500-283-11	INDUCTOR, FERRITE BEAD		IC813	8-759-549-15	IC SN74LV245APWR	
FB754	1-500-283-11	INDUCTOR, FERRITE BEAD		IC814	8-759-649-33	IC SN74AHCT1G08DCKR	
FB755	1-500-283-11	INDUCTOR, FERRITE BEAD		IC815	8-759-649-50	IC SN74AHC1GU04DCKR	
FB756	1-500-283-11	INDUCTOR, FERRITE BEAD		IC901	8-753-223-28	IC CXP973064-241R	
FB759	1-500-283-11	INDUCTOR, FERRITE BEAD		IC902	8-759-546-74	IC TC7WH157FU (TE12R)	
FB761	1-500-283-11	INDUCTOR, FERRITE BEAD		IC903	8-759-640-39	IC BR24C02F-WE2	
FB762	1-500-283-11	INDUCTOR, FERRITE BEAD		IC904	6-802-393-01	IC ISPLSI2032VE-110LT44-SA8	
FB801	1-500-283-11	INDUCTOR, FERRITE BEAD		IC905	8-759-636-64	IC M51957BFP-600C	
FB802	1-500-283-11	INDUCTOR, FERRITE BEAD		IC906	8-759-645-76	IC TC74VHCT32AFT	
FB803	1-500-283-11	INDUCTOR, FERRITE BEAD				< COIL >	
FB804	1-500-283-11	INDUCTOR, FERRITE BEAD					
		< FILTER >		L801	1-410-369-11	CHIP INDUCTOR 1uH	
FL501	1-234-177-21	FILTER, CHIP EMI		L802	1-410-369-11	CHIP INDUCTOR 1uH	
FL502	1-234-177-21	FILTER, CHIP EMI		L803	1-410-369-11	CHIP INDUCTOR 1uH	
FL701	1-234-177-21	FILTER, CHIP EMI				< RESISTOR >	
FL702	1-234-177-21	FILTER, CHIP EMI		R501	1-216-833-11	METAL CHIP 10K 5% 1/10W	
FL703	1-234-177-21	FILTER, CHIP EMI		R502	1-216-833-11	METAL CHIP 10K 5% 1/10W	
FL704	1-234-177-21	FILTER, CHIP EMI		R505	1-216-829-11	METAL CHIP 4.7K 5% 1/10W	
FL705	1-234-177-21	FILTER, CHIP EMI		R506	1-216-829-11	METAL CHIP 4.7K 5% 1/10W	
FL706	1-234-177-21	FILTER, CHIP EMI		R507	1-216-827-11	METAL CHIP 3.3K 5% 1/10W	
FL750	1-233-893-21	FILTER, CHIP EMI		R508	1-216-827-11	METAL CHIP 3.3K 5% 1/10W	
FL751	1-234-177-21	FILTER, CHIP EMI		R509	1-216-833-11	METAL CHIP 10K 5% 1/10W	
FL752	1-234-177-21	FILTER, CHIP EMI		R512	1-216-864-11	SHORT CHIP 0	
FL753	1-234-177-21	FILTER, CHIP EMI		R513	1-216-797-11	METAL CHIP 10 5% 1/10W	
FL754	1-234-177-21	FILTER, CHIP EMI		R516	1-216-797-11	METAL CHIP 10 5% 1/10W	
FL807	1-234-177-21	FILTER, CHIP EMI		R518	1-216-797-11	METAL CHIP 10 5% 1/10W	
FL808	1-234-177-21	FILTER, CHIP EMI		R522	1-216-864-11	SHORT CHIP 0	
FL809	1-234-177-21	FILTER, CHIP EMI		R523	1-216-797-11	METAL CHIP 10 5% 1/10W	
FL810	1-234-177-21	FILTER, CHIP EMI		R524	1-216-833-11	METAL CHIP 10K 5% 1/10W	
FL811	1-234-177-21	FILTER, CHIP EMI		R529	1-218-748-11	METAL CHIP 220K 0.5% 1/10W	
FL812	1-234-177-21	FILTER, CHIP EMI		R530	1-218-748-11	METAL CHIP 220K 0.5% 1/10W	
FL813	1-234-177-21	FILTER, CHIP EMI		R534	1-218-704-11	METAL CHIP 3.3K 0.5% 1/10W	
FL901	1-234-177-21	FILTER, CHIP EMI		R538	1-218-740-11	METAL CHIP 100K 0.5% 1/10W	
FL904	1-234-177-21	FILTER, CHIP EMI		R540	1-216-833-11	METAL CHIP 10K 5% 1/10W	
FL905	1-234-177-21	FILTER, CHIP EMI		R541	1-218-740-11	METAL CHIP 100K 0.5% 1/10W	
FL906	1-234-177-21	FILTER, CHIP EMI		R544	1-218-740-11	METAL CHIP 100K 0.5% 1/10W	
FL908	1-234-177-21	FILTER, CHIP EMI		R545	1-218-740-11	METAL CHIP 100K 0.5% 1/10W	
		< IC >		R554	1-216-827-11	METAL CHIP 3.3K 5% 1/10W	
IC502	8-759-567-26	IC BA5983FP-E2		R555	1-218-704-11	METAL CHIP 3.3K 0.5% 1/10W	
IC503	8-759-701-40	IC NJM3404AM-T1		R556	1-216-827-11	METAL CHIP 3.3K 5% 1/10W	
IC504	8-759-473-95	IC uPC2905T-E1		R558	1-216-841-11	METAL CHIP 47K 5% 1/10W	
IC509	8-752-408-73	IC CXD3068Q		R559	1-216-797-11	METAL CHIP 10 5% 1/10W	
IC512	8-759-490-71	IC BA5912AFP-YE2		R560	1-216-821-11	METAL CHIP 1K 5% 1/10W	
IC701	6-703-552-01	IC TMC57929PGF-RDP		R561	1-216-821-11	METAL CHIP 1K 5% 1/10W	
IC702	8-759-637-50	IC TA48M025F (TE16L)		R562	1-216-821-11	METAL CHIP 1K 5% 1/10W	
IC703	8-759-701-40	IC NJM3404AM-T1		R563	1-216-797-11	METAL CHIP 10 5% 1/10W	
IC706	8-759-564-30	IC MSM51V18165B-60TSKR1		R565	1-216-833-11	METAL CHIP 10K 5% 1/10W	
IC708	8-759-701-40	IC NJM3404AM-T1		R568	1-216-833-11	METAL CHIP 10K 5% 1/10W	
				R572	1-216-797-11	METAL CHIP 10 5% 1/10W	

Ref. No.	Part No.	Description	Remark	Ref. No.	Part No.	Description	Remark
R573	1-216-797-11	METAL CHIP	10 5% 1/10W	R716	1-218-668-11	METAL CHIP	100 0.5% 1/10W
R581	1-216-833-11	METAL CHIP	10K 5% 1/10W	R717	1-218-740-11	METAL CHIP	100K 0.5% 1/10W
R582	1-216-833-11	METAL CHIP	10K 5% 1/10W	R718	1-218-716-11	METAL CHIP	10K 0.5% 1/10W
R584	1-218-728-11	METAL CHIP	33K 0.5% 1/10W	R719	1-218-692-11	METAL CHIP	1K 0.5% 1/10W
R588	1-218-716-11	METAL CHIP	10K 0.5% 1/10W	R720	1-216-821-11	METAL CHIP	1K 5% 1/10W
R589	1-218-728-11	METAL CHIP	33K 0.5% 1/10W	R721	1-218-728-11	METAL CHIP	33K 0.5% 1/10W
R590	1-218-716-11	METAL CHIP	10K 0.5% 1/10W	R724	1-218-692-11	METAL CHIP	1K 0.5% 1/10W
R591	1-218-702-11	METAL CHIP	2.7K 0.5% 1/10W	R725	1-218-698-11	METAL CHIP	1.8K 0.5% 1/10W
R592	1-218-708-11	METAL CHIP	4.7K 0.5% 1/10W	R726	1-218-728-11	METAL CHIP	33K 0.5% 1/10W
R593	1-218-740-11	METAL CHIP	100K 0.5% 1/10W	R727	1-218-704-11	METAL CHIP	3.3K 0.5% 1/10W
R594	1-218-728-11	METAL CHIP	33K 0.5% 1/10W	R728	1-218-716-11	METAL CHIP	10K 0.5% 1/10W
R595	1-218-708-11	METAL CHIP	4.7K 0.5% 1/10W	R730	1-216-801-11	METAL CHIP	22 5% 1/10W
R597	1-218-716-11	METAL CHIP	10K 0.5% 1/10W	R731	1-216-801-11	METAL CHIP	22 5% 1/10W
R599	1-218-702-11	METAL CHIP	2.7K 0.5% 1/10W	R732	1-216-833-11	METAL CHIP	10K 5% 1/10W
R601	1-218-724-11	METAL CHIP	22K 0.5% 1/10W	R733	1-216-833-11	METAL CHIP	10K 5% 1/10W
R602	1-218-708-11	METAL CHIP	4.7K 0.5% 1/10W	R734	1-216-833-11	METAL CHIP	10K 5% 1/10W
R603	1-218-704-11	METAL CHIP	3.3K 0.5% 1/10W	R735	1-216-833-11	METAL CHIP	10K 5% 1/10W
R604	1-218-692-11	METAL CHIP	1K 0.5% 1/10W	R736	1-216-833-11	METAL CHIP	10K 5% 1/10W
R606	1-216-835-11	METAL CHIP	15K 5% 1/10W	R737	1-216-833-11	METAL CHIP	10K 5% 1/10W
R607	1-218-708-11	METAL CHIP	4.7K 0.5% 1/10W	R738	1-216-833-11	METAL CHIP	10K 5% 1/10W
R608	1-218-716-11	METAL CHIP	10K 0.5% 1/10W	R740	1-216-833-11	METAL CHIP	10K 5% 1/10W
R611	1-218-724-11	METAL CHIP	22K 0.5% 1/10W	R741	1-216-801-11	METAL CHIP	22 5% 1/10W
R613	1-216-857-11	METAL CHIP	1M 5% 1/10W	R742	1-216-801-11	METAL CHIP	22 5% 1/10W
R617	1-216-857-11	METAL CHIP	1M 5% 1/10W	R743	1-216-801-11	METAL CHIP	22 5% 1/10W
R618	1-218-911-11	METAL CHIP	470K 0.5% 1/10W	R744	1-216-801-11	METAL CHIP	22 5% 1/10W
R621	1-216-864-11	SHORT CHIP	0	R745	1-216-841-11	METAL CHIP	47K 5% 1/10W
R625	1-216-813-11	METAL CHIP	220 5% 1/10W	R746	1-216-841-11	METAL CHIP	47K 5% 1/10W
R626	1-216-864-11	SHORT CHIP	0	R750	1-216-833-11	METAL CHIP	10K 5% 1/10W
R627	1-216-864-11	SHORT CHIP	0	R755	1-216-864-11	SHORT CHIP	0
R628	1-216-864-11	SHORT CHIP	0	R756	1-216-864-11	SHORT CHIP	0
R632	1-216-833-11	METAL CHIP	10K 5% 1/10W	R757	1-216-864-11	SHORT CHIP	0
R634	1-218-867-11	METAL CHIP	6.8K 0.5% 1/10W	R758	1-216-864-11	SHORT CHIP	0
R642	1-216-839-11	METAL CHIP	33K 5% 1/10W	R759	1-216-864-11	SHORT CHIP	0
R644	1-216-797-11	METAL CHIP	10 5% 1/10W	R760	1-216-864-11	SHORT CHIP	0
R645	1-216-797-11	METAL CHIP	10 5% 1/10W	R761	1-218-700-11	METAL CHIP	2.2K 0.5% 1/10W
R654	1-216-821-11	METAL CHIP	1K 5% 1/10W	R762	1-218-724-11	METAL CHIP	22K 0.5% 1/10W
R655	1-216-821-11	METAL CHIP	1K 5% 1/10W	R763	1-218-714-11	METAL CHIP	8.2K 0.5% 1/10W
R656	1-216-821-11	METAL CHIP	1K 5% 1/10W	R764	1-216-857-11	METAL CHIP	1M 5% 1/10W
R657	1-218-700-11	METAL CHIP	2.2K 0.5% 1/10W	R765	1-218-724-11	METAL CHIP	22K 0.5% 1/10W
R658	1-218-700-11	METAL CHIP	2.2K 0.5% 1/10W	R766	1-216-864-11	SHORT CHIP	0
R659	1-218-700-11	METAL CHIP	2.2K 0.5% 1/10W	R767	1-218-732-11	METAL CHIP	47K 0.5% 1/10W
R660	1-218-700-11	METAL CHIP	2.2K 0.5% 1/10W	R768	1-216-809-11	METAL CHIP	100 5% 1/10W
R661	1-216-864-11	SHORT CHIP	0	R769	1-218-700-11	METAL CHIP	2.2K 0.5% 1/10W
R701	1-218-748-11	METAL CHIP	220K 0.5% 1/10W	R772	1-216-801-11	METAL CHIP	22 5% 1/10W
R702	1-218-740-11	METAL CHIP	100K 0.5% 1/10W	R776	1-216-864-11	SHORT CHIP	0
R703	1-218-740-11	METAL CHIP	100K 0.5% 1/10W	R777	1-216-864-11	SHORT CHIP	0
R704	1-218-748-11	METAL CHIP	220K 0.5% 1/10W	R778	1-218-740-11	METAL CHIP	100K 0.5% 1/10W
R705	1-218-740-11	METAL CHIP	100K 0.5% 1/10W	R780	1-216-864-11	SHORT CHIP	0
R706	1-218-740-11	METAL CHIP	100K 0.5% 1/10W	R781	1-216-864-11	SHORT CHIP	0
R707	1-218-668-11	METAL CHIP	100 0.5% 1/10W	R800	1-216-829-11	METAL CHIP	4.7K 5% 1/10W
R708	1-218-911-11	METAL CHIP	470K 0.5% 1/10W	R801	1-216-829-11	METAL CHIP	4.7K 5% 1/10W
R709	1-218-744-11	METAL CHIP	150K 0.5% 1/10W	R802	1-216-829-11	METAL CHIP	4.7K 5% 1/10W
R710	1-218-716-11	METAL CHIP	10K 0.5% 1/10W	R804	1-216-833-11	METAL CHIP	10K 5% 1/10W
R711	1-218-700-11	METAL CHIP	2.2K 0.5% 1/10W	R806	1-216-833-11	METAL CHIP	10K 5% 1/10W
R712	1-218-716-11	METAL CHIP	10K 0.5% 1/10W	R807	1-216-833-11	METAL CHIP	10K 5% 1/10W
R713	1-218-716-11	METAL CHIP	10K 0.5% 1/10W	R809	1-216-809-11	METAL CHIP	100 5% 1/10W
R714	1-218-716-11	METAL CHIP	10K 0.5% 1/10W	R810	1-216-809-11	METAL CHIP	100 5% 1/10W
				R811	1-216-864-11	SHORT CHIP	0

SCD-XA9000ES

MAIN

Ref. No.	Part No.	Description	Remark	Ref. No.	Part No.	Description	Remark
R813	1-216-801-11	METAL CHIP	22 5% 1/10W	R902	1-216-833-11	METAL CHIP	10K 5% 1/10W
R814	1-216-801-11	METAL CHIP	22 5% 1/10W	R903	1-216-801-11	METAL CHIP	22 5% 1/10W
R815	1-216-801-11	METAL CHIP	22 5% 1/10W	R904	1-216-801-11	METAL CHIP	22 5% 1/10W
R816	1-216-801-11	METAL CHIP	22 5% 1/10W	R905	1-216-801-11	METAL CHIP	22 5% 1/10W
R817	1-216-801-11	METAL CHIP	22 5% 1/10W	R906	1-216-801-11	METAL CHIP	22 5% 1/10W
R818	1-216-801-11	METAL CHIP	22 5% 1/10W	R907	1-216-801-11	METAL CHIP	22 5% 1/10W
R821	1-216-801-11	METAL CHIP	22 5% 1/10W	R908	1-216-833-11	METAL CHIP	10K 5% 1/10W
R822	1-216-801-11	METAL CHIP	22 5% 1/10W	R909	1-216-833-11	METAL CHIP	10K 5% 1/10W
R824	1-216-864-11	SHORT CHIP	0	R910	1-216-864-11	SHORT CHIP	0
R826	1-216-801-11	METAL CHIP	22 5% 1/10W	R911	1-216-821-11	METAL CHIP	1K 5% 1/10W
R827	1-216-809-11	METAL CHIP	100 5% 1/10W	R912	1-216-833-11	METAL CHIP	10K 5% 1/10W
R828	1-216-829-11	METAL CHIP	4.7K 5% 1/10W	R913	1-216-833-11	METAL CHIP	10K 5% 1/10W
R829	1-216-809-11	METAL CHIP	100 5% 1/10W	R915	1-216-809-11	METAL CHIP	100 5% 1/10W
R830	1-216-829-11	METAL CHIP	4.7K 5% 1/10W	R916	1-216-821-11	METAL CHIP	1K 5% 1/10W
R831	1-216-839-11	METAL CHIP	33K 5% 1/10W	R917	1-216-821-11	METAL CHIP	1K 5% 1/10W
R832	1-216-864-11	SHORT CHIP	0	R918	1-216-789-11	METAL CHIP	2.2 5% 1/10W
R833	1-216-864-11	SHORT CHIP	0	R919	1-216-801-11	METAL CHIP	22 5% 1/10W
R834	1-216-864-11	SHORT CHIP	0	R920	1-216-809-11	METAL CHIP	100 5% 1/10W
R835	1-216-864-11	SHORT CHIP	0	R921	1-216-809-11	METAL CHIP	100 5% 1/10W
R836	1-216-864-11	SHORT CHIP	0	R922	1-216-833-11	METAL CHIP	10K 5% 1/10W
R837	1-216-864-11	SHORT CHIP	0	R923	1-216-833-11	METAL CHIP	10K 5% 1/10W
R838	1-216-864-11	SHORT CHIP	0	R925	1-216-809-11	METAL CHIP	100 5% 1/10W
R839	1-216-829-11	METAL CHIP	4.7K 5% 1/10W	R926	1-216-809-11	METAL CHIP	100 5% 1/10W
R840	1-216-864-11	SHORT CHIP	0	R929	1-216-809-11	METAL CHIP	100 5% 1/10W
R841	1-216-864-11	SHORT CHIP	0	R931	1-216-833-11	METAL CHIP	10K 5% 1/10W
R842	1-216-864-11	SHORT CHIP	0	R932	1-216-801-11	METAL CHIP	22 5% 1/10W
R847	1-216-801-11	METAL CHIP	22 5% 1/10W	R933	1-216-864-11	SHORT CHIP	0
R848	1-216-801-11	METAL CHIP	22 5% 1/10W	R935	1-216-833-11	METAL CHIP	10K 5% 1/10W
R849	1-216-801-11	METAL CHIP	22 5% 1/10W	R940	1-216-809-11	METAL CHIP	100 5% 1/10W
R850	1-216-801-11	METAL CHIP	22 5% 1/10W	R941	1-216-809-11	METAL CHIP	100 5% 1/10W
R851	1-216-864-11	SHORT CHIP	0	R942	1-216-809-11	METAL CHIP	100 5% 1/10W
R852	1-216-864-11	SHORT CHIP	0	R943	1-216-809-11	METAL CHIP	100 5% 1/10W
R853	1-216-813-11	METAL CHIP	220 5% 1/10W	R946	1-216-833-11	METAL CHIP	10K 5% 1/10W
R854	1-216-813-11	METAL CHIP	220 5% 1/10W	R947	1-216-864-11	SHORT CHIP	0
R855	1-216-813-11	METAL CHIP	220 5% 1/10W	R948	1-218-712-11	METAL CHIP	6.8K 0.5% 1/10W
R857	1-216-813-11	METAL CHIP	220 5% 1/10W	R949	1-218-712-11	METAL CHIP	6.8K 0.5% 1/10W
R858	1-216-819-11	METAL CHIP	680 5% 1/10W	R951	1-216-821-11	METAL CHIP	1K 5% 1/10W
R859	1-216-819-11	METAL CHIP	680 5% 1/10W	R955	1-216-801-11	METAL CHIP	22 5% 1/10W
R860	1-216-813-11	METAL CHIP	220 5% 1/10W	R956	1-216-833-11	METAL CHIP	10K 5% 1/10W
R861	1-216-809-11	METAL CHIP	100 5% 1/10W	R957	1-216-801-11	METAL CHIP	22 5% 1/10W
R862	1-216-809-11	METAL CHIP	100 5% 1/10W	R958	1-218-716-11	METAL CHIP	10K 0.5% 1/10W
R863	1-216-833-11	METAL CHIP	10K 5% 1/10W	R959	1-216-833-11	METAL CHIP	10K 5% 1/10W
R864	1-216-809-11	METAL CHIP	100 5% 1/10W	R960	1-216-833-11	METAL CHIP	10K 5% 1/10W
R865	1-218-740-11	METAL CHIP	100K 0.5% 1/10W	R961	1-216-821-11	METAL CHIP	1K 5% 1/10W
R866	1-216-813-11	METAL CHIP	220 5% 1/10W	R962	1-216-833-11	METAL CHIP	10K 5% 1/10W
R867	1-216-813-11	METAL CHIP	220 5% 1/10W	R963	1-218-692-11	METAL CHIP	1K 0.5% 1/10W
R868	1-216-805-11	METAL CHIP	47 5% 1/10W	R964	1-218-692-11	METAL CHIP	1K 0.5% 1/10W
R870	1-218-716-11	METAL CHIP	10K 0.5% 1/10W	R965	1-216-833-11	METAL CHIP	10K 5% 1/10W
R882	1-216-833-11	METAL CHIP	10K 5% 1/10W	R970	1-216-833-11	METAL CHIP	10K 5% 1/10W
R883	1-216-833-11	METAL CHIP	10K 5% 1/10W	R971	1-216-809-11	METAL CHIP	100 5% 1/10W
R884	1-216-833-11	METAL CHIP	10K 5% 1/10W	R973	1-216-864-11	SHORT CHIP	0
R885	1-216-833-11	METAL CHIP	10K 5% 1/10W	R975	1-216-833-11	METAL CHIP	10K 5% 1/10W
R886	1-216-833-11	METAL CHIP	10K 5% 1/10W	R978	1-216-833-11	METAL CHIP	10K 5% 1/10W
R887	1-216-833-11	METAL CHIP	10K 5% 1/10W	R980	1-216-825-11	METAL CHIP	2.2K 5% 1/10W
R888	1-216-833-11	METAL CHIP	10K 5% 1/10W	R981	1-216-833-11	METAL CHIP	10K 5% 1/10W
R889	1-216-833-11	METAL CHIP	10K 5% 1/10W	R982	1-216-801-11	METAL CHIP	22 5% 1/10W
R901	1-216-801-11	METAL CHIP	22 5% 1/10W	R983	1-216-801-11	METAL CHIP	22 5% 1/10W
				R985	1-216-864-11	SHORT CHIP	0

MAIN **MOTHER**

Ref. No.	Part No.	Description	Remark	Ref. No.	Part No.	Description	Remark	
R986	1-216-864-11	SHORT CHIP	0	R1061	1-216-864-11	SHORT CHIP	0	
R988	1-216-821-11	METAL CHIP	1K	R1062	1-216-864-11	SHORT CHIP	0	
R991	1-216-864-11	SHORT CHIP	0	R1063	1-216-864-11	SHORT CHIP	0	
R992	1-216-864-11	SHORT CHIP	0	R1064	1-216-864-11	SHORT CHIP	0	
R993	1-216-864-11	SHORT CHIP	0	R1065	1-216-864-11	SHORT CHIP	0	
R994	1-216-864-11	SHORT CHIP	0	R1066	1-216-864-11	SHORT CHIP	0	
R995	1-216-864-11	SHORT CHIP	0	R1067	1-216-864-11	SHORT CHIP	0	
R996	1-216-864-11	SHORT CHIP	0	R1068	1-216-864-11	SHORT CHIP	0	
R997	1-216-864-11	SHORT CHIP	0	R1069	1-216-864-11	SHORT CHIP	0	
R998	1-216-864-11	SHORT CHIP	0	R1070	1-216-864-11	SHORT CHIP	0	
R999	1-216-864-11	SHORT CHIP	0	R1072	1-216-864-11	SHORT CHIP	0	
R1000	1-216-864-11	SHORT CHIP	0	< VIBRATOR >				
R1002	1-216-833-11	METAL CHIP	10K	5%	1/10W	X901	1-781-945-21	VIBRATOR, CERAMIC (20MHz)
R1003	1-216-833-11	METAL CHIP	10K	5%	1/10W	*****		
R1014	1-216-864-11	SHORT CHIP	0	A-4747-510-A MOTHER BOARD, COMPLETE (AEP)				
R1015	1-216-801-11	METAL CHIP	22	5%	1/10W	A-4747-598-A MOTHER BOARD, COMPLETE (EXCEPT AEP)		
R1018	1-216-801-11	METAL CHIP	22	5%	1/10W	*****		
R1019	1-216-864-11	SHORT CHIP	0	< CAPACITOR >				
R1020	1-216-833-11	METAL CHIP	10K	5%	1/10W	C301	1-115-198-11	ELECT 470uF 20% 25V
R1021	1-216-821-11	METAL CHIP	1K	5%	1/10W	C302	1-115-198-11	ELECT 470uF 20% 25V
R1022	1-216-832-11	METAL CHIP	8.2K	5%	1/10W	C303	1-165-319-11	CERAMIC CHIP 0.1uF 50V
R1023	1-216-864-11	SHORT CHIP	0	C304	1-117-914-51	ELECT 330uF 20% 25V		
R1026	1-216-833-11	METAL CHIP	10K	5%	1/10W	C305	1-136-960-11	FILM 0.1uF 10% 160V
R1027	1-216-843-11	METAL CHIP	68K	5%	1/10W	C306	1-165-627-21	FILM 27PF 10% 50V
R1028	1-216-809-11	METAL CHIP	100	5%	1/10W	C307	1-165-627-21	FILM 27PF 10% 50V
R1029	1-216-832-11	METAL CHIP	8.2K	5%	1/10W	C308	1-136-850-11	MYLAR 0.1uF 5% 63V
R1030	1-216-809-11	METAL CHIP	100	5%	1/10W	C309	1-136-850-11	MYLAR 0.1uF 5% 63V
R1031	1-216-864-11	SHORT CHIP	0	C310	1-136-850-11	MYLAR 0.1uF 5% 63V		
R1032	1-216-864-11	SHORT CHIP	0	C311	1-136-850-11	MYLAR 0.1uF 5% 63V		
R1033	1-216-864-11	SHORT CHIP	0	C312	1-136-850-11	MYLAR 0.1uF 5% 63V		
R1034	1-216-864-11	SHORT CHIP	0	C313	1-136-850-11	MYLAR 0.1uF 5% 63V		
R1035	1-216-864-11	SHORT CHIP	0	C314	1-119-800-11	ELECT 100uF 20% 25V		
R1036	1-216-864-11	SHORT CHIP	0	C315	1-165-319-11	CERAMIC CHIP 0.1uF 50V		
R1037	1-216-864-11	SHORT CHIP	0	C330	1-125-853-21	FILM 470PF 5% 50V		
R1038	1-216-864-11	SHORT CHIP	0	C331	1-163-141-00	CERAMIC CHIP 0.001uF 5% 50V		
R1039	1-216-864-11	SHORT CHIP	0	C332	1-163-141-00	CERAMIC CHIP 0.001uF 5% 50V		
R1040	1-216-864-11	SHORT CHIP	0	C333	1-163-141-00	CERAMIC CHIP 0.001uF 5% 50V		
R1041	1-216-864-11	SHORT CHIP	0	C335	1-128-201-11	ELECT 100uF 20% 63V		
R1042	1-216-864-11	SHORT CHIP	0	C351	1-128-201-11	ELECT 100uF 20% 63V		
R1043	1-216-864-11	SHORT CHIP	0	C352	1-128-201-11	ELECT 100uF 20% 63V		
R1044	1-216-864-11	SHORT CHIP	0	C353	1-128-655-21	FILM 22PF 10% 50V		
R1045	1-216-864-11	SHORT CHIP	0	C354	1-128-655-21	FILM 22PF 10% 50V		
R1046	1-216-864-11	SHORT CHIP	0	C355	1-136-960-11	FILM 0.1uF 10% 160V		
R1047	1-216-864-11	SHORT CHIP	0	C356	1-136-960-11	FILM 0.1uF 10% 160V		
R1048	1-216-864-11	SHORT CHIP	0	C357	1-136-960-11	FILM 0.1uF 10% 160V		
R1049	1-216-864-11	SHORT CHIP	0	C360	1-128-201-11	ELECT 100uF 20% 63V		
R1050	1-216-864-11	SHORT CHIP	0	C361	1-128-201-11	ELECT 100uF 20% 63V		
R1051	1-216-864-11	SHORT CHIP	0	C362	1-136-960-11	FILM 0.1uF 10% 160V		
R1052	1-216-864-11	SHORT CHIP	0	C365	1-128-201-11	ELECT 100uF 20% 63V		
R1053	1-216-864-11	SHORT CHIP	0	C366	1-128-201-11	ELECT 100uF 20% 63V		
R1054	1-216-864-11	SHORT CHIP	0	C367	1-136-960-11	FILM 0.1uF 10% 160V		
R1055	1-216-864-11	SHORT CHIP	0	C368	1-165-319-11	CERAMIC CHIP 0.1uF 50V		
R1056	1-216-864-11	SHORT CHIP	0	C369	1-136-960-11	FILM 0.1uF 10% 160V		
R1057	1-216-864-11	SHORT CHIP	0	C370	1-163-117-00	CERAMIC CHIP 100PF 5% 50V		
R1058	1-216-864-11	SHORT CHIP	0	C371	1-163-117-00	CERAMIC CHIP 100PF 5% 50V		
R1059	1-216-864-11	SHORT CHIP	0					
R1060	1-216-864-11	SHORT CHIP	0					

SCD-XA9000ES

Ver 1.2

MOTHER

Ref. No.	Part No.	Description	Remark	Ref. No.	Part No.	Description	Remark
C372	1-119-791-21	ELECT	330uF 20% 16V			< JACK >	
C373	1-127-713-21	FILM	10000PF 5% 50V				
C374	1-127-713-21	FILM	10000PF 5% 50V	J351	1-815-742-11	JACK, PIN 2P (ANALOG 2CH OUT)	
C380	1-163-117-00	CERAMIC CHIP	100PF 5% 50V			< COIL >	
C381	1-163-117-00	CERAMIC CHIP	100PF 5% 50V				
C382	1-119-791-21	ELECT	330uF 20% 16V	L301	1-424-153-11	FILTER, NOISE	
C383	1-165-319-11	CERAMIC CHIP	0.1uF 50V	L371	1-408-619-31	MICRO INDUCTOR	220uH
C384	1-165-319-11	CERAMIC CHIP	0.1uF 50V	L381	1-408-619-31	MICRO INDUCTOR	220uH
C390	1-165-319-11	CERAMIC CHIP	0.1uF 50V			< TRANSISTOR >	
C391	1-119-801-21	ELECT	220uF 20% 25V	Q371	8-729-141-74	TRANSISTOR	2SC3624A-T2L15L16
C392	1-119-801-21	ELECT	220uF 20% 25V	Q381	8-729-141-74	TRANSISTOR	2SC3624A-T2L15L16
C393	1-117-720-11	CERAMIC CHIP	4.7uF 10V	Q391	8-729-900-53	TRANSISTOR	DTC114EK
		< CONNECTOR >		Q392	8-729-207-71	TRANSISTOR	RN2405
CN301	1-770-167-11	CONNECTOR, FFC/FPC 19P		Q393	8-729-027-38	TRANSISTOR	DTA144EKA-T146
CN302	1-770-167-11	CONNECTOR, FFC/FPC 19P		Q394	8-729-900-53	TRANSISTOR	DTC114EK
CN304	1-774-628-11	CONNECTOR, BOARD TO BOARD 17P		Q395	8-729-207-71	TRANSISTOR	RN2405
CN305	1-766-956-11	CONNECTOR, BOARD TO BOARD 15P				< RESISTOR >	
CN306	1-766-956-11	CONNECTOR, BOARD TO BOARD 15P		R301	1-216-041-00	RES-CHIP	470 5% 1/10W
* CN352	1-770-723-11	CONNECTOR, BOARD TO BOARD 8P		R302	1-260-032-11	CARBON MELF	1M 2% 1/8W
* CN353	1-770-723-11	CONNECTOR, BOARD TO BOARD 8P		R303	1-216-025-11	RES-CHIP	100 5% 1/10W
* CN354	1-770-723-11	CONNECTOR, BOARD TO BOARD 8P		R304	1-216-033-00	RES-CHIP	220 5% 1/10W
* CN392	1-506-468-11	PIN, CONNECTOR 3P		R305	1-216-033-00	RES-CHIP	220 5% 1/10W
		< DIODE >		R306	1-216-025-11	RES-CHIP	100 5% 1/10W (AEP)
D151	8-719-069-60	DIODE UDZSTE-179.1B		R306	1-216-029-00	RES-CHIP	150 5% 1/10W (EXCEPT AEP)
D301	8-719-049-09	DIODE 1SS367-T3SONY		R307	1-216-025-11	RES-CHIP	100 5% 1/10W
D351	8-719-016-74	DIODE 1SS352		R308	1-216-025-11	RES-CHIP	100 5% 1/10W
D353	8-719-016-74	DIODE 1SS352		R309	1-216-025-11	RES-CHIP	100 5% 1/10W
D354	8-719-016-74	DIODE 1SS352		R310	1-216-025-11	RES-CHIP	100 5% 1/10W
D390	8-719-069-60	DIODE UDZSTE-179.1B		R311	1-216-025-11	RES-CHIP	100 5% 1/10W
D391	8-719-016-74	DIODE 1SS352		R313	1-216-025-11	RES-CHIP	100 5% 1/10W
		< SHORT >		R314	1-216-025-11	RES-CHIP	100 5% 1/10W
FB302	1-216-295-00	SHORT CHIP	0	R315	1-216-025-11	RES-CHIP	100 5% 1/10W
		< RESISTOR >		R317	1-216-025-11	RES-CHIP	100 5% 1/10W
△ FR390	1-212-881-11	FUSIBLE	100 5% 1/4W	R318	1-216-025-11	RES-CHIP	100 5% 1/10W
△ FR391	1-212-889-00	FUSIBLE	220 5% 1/4W	R319	1-216-025-11	RES-CHIP	100 5% 1/10W
△ FR392	1-212-889-00	FUSIBLE	220 5% 1/4W	R321	1-216-025-11	RES-CHIP	100 5% 1/10W
△ FR393	1-212-881-11	FUSIBLE	100 5% 1/4W	R322	1-216-025-11	RES-CHIP	100 5% 1/10W
△ FR394	1-212-881-11	FUSIBLE	100 5% 1/4W	R323	1-212-865-00	FUSIBLE	22 5% 1/4W
		< IC >		R324	1-216-025-11	RES-CHIP	100 5% 1/10W
IC301	8-759-486-55	IC NJM2370U33-TE2		R325	1-216-025-11	RES-CHIP	100 5% 1/10W
IC302	8-759-591-61	IC TC7WHU04FU (TE12R)		R326	1-216-073-00	RES-CHIP	10K 5% 1/10W
IC303	6-700-067-01	IC HD74LV161ATELL		R327	1-216-073-00	RES-CHIP	10K 5% 1/10W
IC304	8-759-549-07	IC SN74LV157APWR		R328	1-216-073-00	RES-CHIP	10K 5% 1/10W
IC305	8-759-549-07	IC SN74LV157APWR		R329	1-216-073-00	RES-CHIP	10K 5% 1/10W
IC306	8-759-549-07	IC SN74LV157APWR		R351	1-260-012-11	CARBON MELF	22K 2% 1/8W
IC307	8-759-549-07	IC SN74LV157APWR		R352	1-260-012-11	CARBON MELF	22K 2% 1/8W
IC308	8-759-549-07	IC SN74LV157APWR		R353	1-260-012-11	CARBON MELF	22K 2% 1/8W
IC351	8-759-566-39	IC OPA2132UA/2K5		R354	1-249-427-11	CARBON	6.8K 5% 1/4W
IC352	8-759-566-39	IC OPA2132UA/2K5		R355	1-216-296-11	SHORT CHIP	0
IC371	8-759-711-85	IC NJM4580E-D		R356	1-260-002-11	CARBON MELF	3.3K 2% 1/8W
				R357	1-259-971-11	CARBON MELF	10 2% 1/8W
				R358	1-259-983-11	CARBON MELF	100 2% 1/8W
				R359	1-260-028-11	CARBON MELF	470K 2% 1/8W
				R360	1-260-002-11	CARBON MELF	3.3K 2% 1/8W

The components identified by mark △ or dotted line with mark △ are critical for safety. Replace only with part number specified.

Les composants identifiés par une marque △ sont critiques pour la sécurité. Ne les remplacer que par une pièce portant le numéro spécifié.

MOTHER	RF
--------	----

Ref. No.	Part No.	Description	Remark	Ref. No.	Part No.	Description	Remark
R361	1-260-012-11	CARBON MELF 22K	2% 1/8W	C015	1-124-779-00	ELECT CHIP 10uF	20% 16V
R362	1-260-012-11	CARBON MELF 22K	2% 1/8W	C016	1-164-218-11	CERAMIC CHIP 180PF	5% 50V
R363	1-260-012-11	CARBON MELF 22K	2% 1/8W	C017	1-162-919-11	CERAMIC CHIP 22PF	5% 50V
R364	1-249-427-11	CARBON 6.8K	5% 1/4W	C018	1-162-919-11	CERAMIC CHIP 22PF	5% 50V
R365	1-216-296-11	SHORT CHIP 0		C019	1-124-779-00	ELECT CHIP 10uF	20% 16V
R366	1-260-002-11	CARBON MELF 3.3K	2% 1/8W	C020	1-162-919-11	CERAMIC CHIP 22PF	5% 50V
R367	1-259-971-11	CARBON MELF 10	2% 1/8W	C021	1-162-919-11	CERAMIC CHIP 22PF	5% 50V
R368	1-259-983-11	CARBON MELF 100	2% 1/8W	C022	1-164-357-11	CERAMIC CHIP 0.001uF	5% 50V
R369	1-260-028-11	CARBON MELF 470K	2% 1/8W	C023	1-126-206-11	ELECT CHIP 100uF	20% 6.3V
R370	1-260-002-11	CARBON MELF 3.3K	2% 1/8W	C024	1-162-974-11	CERAMIC CHIP 0.01uF	50V
R371	1-216-093-11	RES-CHIP 68K	5% 1/10W	C025	1-164-156-11	CERAMIC CHIP 0.1uF	25V
R372	1-216-085-00	RES-CHIP 33K	5% 1/10W	C026	1-162-970-11	CERAMIC CHIP 0.01uF	10% 25V
R373	1-216-085-00	RES-CHIP 33K	5% 1/10W	C027	1-164-156-11	CERAMIC CHIP 0.1uF	25V
R374	1-216-093-11	RES-CHIP 68K	5% 1/10W	C028	1-128-993-21	ELECT CHIP 22uF	20% 10V
R375	1-216-065-00	RES-CHIP 4.7K	5% 1/10W	C029	1-124-779-00	ELECT CHIP 10uF	20% 16V
R376	1-216-019-00	RES-CHIP 56	5% 1/10W	C030	1-128-993-21	ELECT CHIP 22uF	20% 10V
R381	1-216-085-00	RES-CHIP 33K	5% 1/10W	C031	1-107-826-11	CERAMIC CHIP 0.1uF	10% 16V
R382	1-216-093-11	RES-CHIP 68K	5% 1/10W	C032	1-107-826-11	CERAMIC CHIP 0.1uF	10% 16V
R383	1-216-085-00	RES-CHIP 33K	5% 1/10W	C033	1-128-993-21	ELECT CHIP 22uF	20% 10V
R384	1-216-093-11	RES-CHIP 68K	5% 1/10W	C034	1-124-779-00	ELECT CHIP 10uF	20% 16V
R385	1-216-065-00	RES-CHIP 4.7K	5% 1/10W	C036	1-164-156-11	CERAMIC CHIP 0.1uF	25V
R386	1-216-019-00	RES-CHIP 56	5% 1/10W	C037	1-164-357-11	CERAMIC CHIP 0.001uF	5% 50V
R390	1-216-081-00	RES-CHIP 22K	5% 1/10W	C038	1-126-206-11	ELECT CHIP 100uF	20% 6.3V
R391	1-216-081-00	RES-CHIP 22K	5% 1/10W	C039	1-107-826-11	CERAMIC CHIP 0.1uF	10% 16V
R392	1-216-105-00	RES-CHIP 220K	5% 1/10W	C040	1-162-970-11	CERAMIC CHIP 0.01uF	10% 25V
R393	1-216-097-11	RES-CHIP 100K	5% 1/10W	C041	1-162-970-11	CERAMIC CHIP 0.01uF	10% 25V
R394	1-216-049-11	RES-CHIP 1K	5% 1/10W	C042	1-164-677-11	CERAMIC CHIP 0.033uF	10% 16V
R395	1-216-073-00	RES-CHIP 10K	5% 1/10W	C043	1-164-677-11	CERAMIC CHIP 0.033uF	10% 16V
R396	1-216-073-00	RES-CHIP 10K	5% 1/10W	C044	1-162-959-11	CERAMIC CHIP 330PF	5% 50V
		< RELAY >		C045	1-115-416-11	CERAMIC CHIP 0.001uF	5% 25V
RY351	1-755-295-11	RELAY		C046	1-125-891-11	CERAMIC CHIP 0.47uF	10% 10V
RY352	1-755-295-11	RELAY		C047	1-107-826-11	CERAMIC CHIP 0.1uF	10% 16V
RY353	1-755-295-11	RELAY		C048	1-165-176-11	CERAMIC CHIP 0.047uF	10% 16V
		< VIBRATOR >		C049	1-128-993-21	ELECT CHIP 22uF	20% 10V
X301	1-767-406-21	VIBRATOR, CRYSTAL (11.2896MHz)		C050	1-128-993-21	ELECT CHIP 22uF	20% 10V
*****				C051	1-164-156-11	CERAMIC CHIP 0.1uF	25V
	A-1167-570-A	RF BOARD, COMPLETE (AEP: SILVER)		C052	1-164-156-11	CERAMIC CHIP 0.1uF	25V
	A-4747-590-A	RF BOARD, COMPLETE (EXCEPT AEP: SILVER)		C055	1-128-993-21	ELECT CHIP 22uF	20% 10V
		*****		C060	1-115-156-11	CERAMIC CHIP 1uF	10V
		< CAPACITOR >		C064	1-164-156-11	CERAMIC CHIP 0.1uF	25V
C001	1-162-966-11	CERAMIC CHIP 0.0022uF	10% 50V	C068	1-115-156-11	CERAMIC CHIP 1uF	10V
C002	1-162-966-11	CERAMIC CHIP 0.0022uF	10% 50V	C069	1-115-156-11	CERAMIC CHIP 1uF	10V
C003	1-107-826-11	CERAMIC CHIP 0.1uF	10% 16V	C070	1-128-993-21	ELECT CHIP 22uF	20% 10V
C004	1-115-156-11	CERAMIC CHIP 1uF	10V	C071	1-128-993-21	ELECT CHIP 22uF	20% 10V
C005	1-128-993-21	ELECT CHIP 22uF	20% 10V	C081	1-164-357-11	CERAMIC CHIP 0.001uF	5% 50V
C006	1-115-156-11	CERAMIC CHIP 1uF	10V	C082	1-164-357-11	CERAMIC CHIP 0.001uF	5% 50V
C007	1-124-779-00	ELECT CHIP 10uF	20% 16V	C084	1-107-826-11	CERAMIC CHIP 0.1uF	10% 16V
C008	1-162-966-11	CERAMIC CHIP 0.0022uF	10% 50V	C094	1-128-993-21	ELECT CHIP 22uF	20% 10V
C009	1-162-966-11	CERAMIC CHIP 0.0022uF	10% 50V	C095	1-164-156-11	CERAMIC CHIP 0.1uF	25V
C010	1-162-966-11	CERAMIC CHIP 0.0022uF	10% 50V			< CONNECTOR >	
C011	1-162-966-11	CERAMIC CHIP 0.0022uF	10% 50V	CN001	1-774-731-21	PIN, CONNECTOR (PC BOARD) 5P	
C012	1-164-172-11	CERAMIC CHIP 0.0056uF	10% 25V	CN002	1-770-161-21	PIN, CONNECTOR (PC BOARD) 6P	
C013	1-164-172-11	CERAMIC CHIP 0.0056uF	10% 25V	CN003	1-794-707-11	CONNECTOR, FFC/FPC 25P	
C014	1-124-779-00	ELECT CHIP 10uF	20% 16V	CN005	1-784-883-21	CONNECTOR, FFC (LIF (NON-ZIF)) 35P	

SCD-XA9000ES

Ver. 1.3



Ref. No.	Part No.	Description	Remark
< DIODE >			
D001	8-719-016-74	DIODE 1SS352	
D002	8-719-016-74	DIODE 1SS352	
< IC >			
IC001	8-752-424-87	IC CXD1881AR-2	
IC004	8-759-058-45	IC NJM3403AV	
IC081	8-759-701-40	IC NJM3404AM-T1	
< COIL >			
L001	1-412-031-11	CHIP INDUCTOR 47uH	
L002	1-412-031-11	CHIP INDUCTOR 47uH	
L003	1-412-031-11	CHIP INDUCTOR 47uH	
< TRANSISTOR >			
Q001	8-729-805-25	TRANSISTOR 2SB1121-S	
Q002	8-729-805-25	TRANSISTOR 2SB1121-S	
Q003	8-729-805-25	TRANSISTOR 2SB1121-S	
Q005	8-729-820-90	TRANSISTOR 2SD1621-ST	
< RESISTOR >			
R001	1-216-864-11	SHORT CHIP 0	
R002	1-218-668-11	METAL CHIP 100	0.5% 1/10W
R003	1-216-839-11	METAL CHIP 33K	5% 1/10W
R005	1-216-864-11	SHORT CHIP 0	
R006	1-216-864-11	SHORT CHIP 0	
R007	1-216-864-11	SHORT CHIP 0	
R008	1-216-864-11	SHORT CHIP 0	
R011	1-216-864-11	SHORT CHIP 0	
R012	1-216-864-11	SHORT CHIP 0	
R013	1-216-864-11	SHORT CHIP 0	
R014	1-216-864-11	SHORT CHIP 0	
R015	1-216-803-11	METAL CHIP 33	5% 1/10W
R016	1-216-821-11	METAL CHIP 1K	5% 1/10W
R017	1-216-817-11	METAL CHIP 470	5% 1/10W
R018	1-216-821-11	METAL CHIP 1K	5% 1/10W
R019	1-216-803-11	METAL CHIP 33	5% 1/10W
R020	1-216-817-11	METAL CHIP 470	5% 1/10W
R021	1-219-570-11	METAL CHIP 10M	5% 1/10W
R022	1-218-718-11	METAL CHIP 12K	0.5% 1/10W
R023	1-216-864-11	SHORT CHIP 0	
R024	1-216-864-11	SHORT CHIP 0	
R025	1-216-864-11	SHORT CHIP 0	
R027	1-216-864-11	SHORT CHIP 0	
R029	1-216-841-11	METAL CHIP 47K	5% 1/10W
R030	1-216-864-11	SHORT CHIP 0	
R031	1-216-864-11	SHORT CHIP 0	
R032	1-216-864-11	SHORT CHIP 0	
R033	1-216-864-11	SHORT CHIP 0	
R036	1-216-833-11	METAL CHIP 10K	5% 1/10W
R044	1-216-832-11	METAL CHIP 8.2K	5% 1/10W
R046	1-218-668-11	METAL CHIP 100	0.5% 1/10W
R053	1-216-864-11	SHORT CHIP 0	
R054	1-216-864-11	SHORT CHIP 0	
R060	1-216-864-11	SHORT CHIP 0	
R065	1-218-716-11	METAL CHIP 10K	0.5% 1/10W
R066	1-218-716-11	METAL CHIP 10K	0.5% 1/10W

Ref. No.	Part No.	Description	Remark
R068	1-216-839-11	METAL CHIP 33K	5% 1/10W
R082	1-216-833-11	METAL CHIP 10K	5% 1/10W
R083	1-216-833-11	METAL CHIP 10K	5% 1/10W
R084	1-216-833-11	METAL CHIP 10K	5% 1/10W
R085	1-216-833-11	METAL CHIP 10K	5% 1/10W
R086	1-216-833-11	METAL CHIP 10K	5% 1/10W
R087	1-216-833-11	METAL CHIP 10K	5% 1/10W
R088	1-216-864-11	SHORT CHIP 0	
R089	1-216-864-11	SHORT CHIP 0	
R093	1-216-803-11	METAL CHIP 33	5% 1/10W
R094	1-216-803-11	METAL CHIP 33	5% 1/10W
R097	1-216-839-11	METAL CHIP 33K	5% 1/10W
R098	1-216-839-11	METAL CHIP 33K	5% 1/10W
R100	1-249-417-11	CARBON 1K	5% 1/4W
(AEP: SILVER)			

*	1-641-764-13	SW BOARD	*****
< CAPACITOR >			
C001	1-161-494-00	CERAMIC 0.022uF	25V
< SWITCH >			
S001	1-571-300-11	SWITCH, ROTARY (LOADING IN)	
S002	1-571-300-11	SWITCH, ROTARY (LOADING OUT)	

MISCELLANEOUS			

203	1-775-172-11	WIRE (FLAT TYPE) (19 CORE)	
204	1-775-225-11	WIRE (FLAT TYPE) (25 CORE)	
206	1-757-098-11	WIRE (FLAT TYPE) (35 CORE)	
256	1-555-724-00	WIRE, GROUND (US, Canadian)	
△ 552	8-820-132-03	OPTICAL PICK-UP (KHM-230AAA/J1RP)	(EXCEPT AEP: SIVLER)
△ 552	8-820-132-09	OPTICAL PICK-UP (KHM-230AAA/J1RP1)	(AEP: SILVER)
557	1-757-097-11	WIRE (FLAT TYPE) (25 CORE)	
M1	A-4604-347-A	MOTOR (L) ASSY (LOADING)	
△ T901	1-437-420-12	TRANSFORMER, POWER (AEP)	
△ T901	1-437-422-12	TRANSFORMER, POWER (EXCEPT AEP)	
△ T902	1-437-421-12	TRANSFORMER, POWER (AEP)	
△ T902	1-437-423-12	TRANSFORMER, POWER (EXCEPT AEP)	

<p>The components identified by mark △ or dotted line with mark △ are critical for safety. Replace only with part number specified.</p>	<p>Les composants identifiés par une marque △ sont critiques pour la sécurité. Ne les remplacer que par une pièce portant le numéro spécifié.</p>
---	---

Ref. No.	Part No.	Description	Remark
		ACCESSORIES *****	
	1-476-598-13	REMOTE COMMANDER (RM-SX700)	
△	1-793-461-11	PLUG, CONVERSION (3P-2P) (US, Canadian)	
△	1-551-631-22	CORD, POWER (AEP)	
△	1-551-812-11	CORD, POWER (US, Canadian)	
	1-757-167-21	CORD, CONNECTION (i.LINK CONNECTING CORD)	
	1-757-960-22	CORD, CONNECTION (BLACK) (CENTOR or SUB WOOFER CONNECTION)	
	1-791-732-12	CORD, CONNECTION (RED and WHITE) (FRONT/SURR CONNECTION)	
△	1-828-109-11	CORD, POWER (Taiwan)	
	4-228-696-01	COVER, BATTERY (for RM-SX700)	
	4-249-411-12	MANUAL, INSTRUCTION (ENGLISH, FRENCH)	
	4-249-411-21	MANUAL, INSTRUCTION (GERMAN, SPANISH) (AEP)	
	4-249-411-31	MANUAL, INSTRUCTION (DUTCH, ITALIAN, SWEDISH, POLISH) (AEP)	
	4-249-411-41	MANUAL, INSTRUCTION (POLTUGUESE) (AEP)	
	4-249-411-51	MANUAL, INSTRUCTION (DANISH, FINNISH) (AEP)	
	4-249-411-61	MANUAL, INSTRUCTION (RUSSIAN) (AEP)	
	4-249-411-71	MANUAL, INSTRUCTION (ENGLISH, SIMPLIFIED CHINESE) (Taiwan)	
	4-249-412-11	MANUAL, INSTRUCTION (GREEK) (AEP)	
	4-249-412-21	MANUAL, INSTRUCTION (HUNGARIAN, CZECH) (AEP)	
	4-249-412-31	MANUAL, INSTRUCTION (TURKISH) (AEP)	
	4-249-412-41	MANUAL, INSTRUCTION (SLOVAKIAN) (AEP)	

The components identified by mark △ or dotted line with mark △ are critical for safety. Replace only with part number specified.

Les composants identifiés par une marque △ sont critiques pour la sécurité. Ne les remplacer que par une pièce portant le numéro spécifié.

