

FOR SERVICE MANUALS  
CONTACT:  
**MAURITRON TECHNICAL SERVICES**

www.mauritron.co.uk  
TEL: 01844 - 351694  
FAX: 01844 - 352554

# ST-2950F

*UK Model*  
*AEP Model*

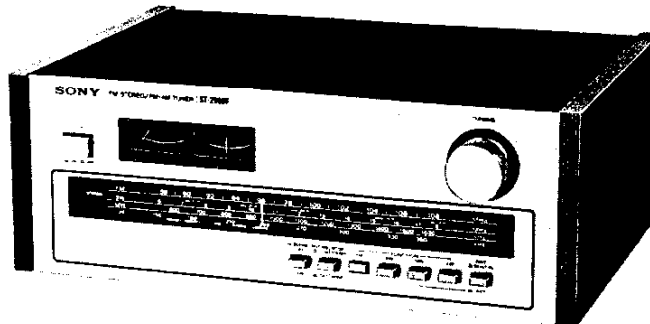

## FM STEREO/FM-AM TUNER

### SPECIFICATIONS

#### GENERAL

**Power Requirements:** 110, 127, 220 or 240 V ac adjustable,  
50/60 Hz

**Power Consumption:** 23 W

**Dimensions:** Approx. 390 (w) x 145 (h) x 310 (d) mm  
15<sup>3</sup>/<sub>8</sub> (w) x 5<sup>3</sup>/<sub>4</sub> (h) x 12<sup>1</sup>/<sub>4</sub> (d) inches  
Including projecting parts and controls

**Weight:** Approx. 6.0 kg, 13 lb 4 oz (net)  
Approx. 7.8 kg, 17 lb 2 oz (with shipping  
carton)

#### FM SECTION

**Tuning Range:** 87.5 MHz – 108 MHz

**Antenna Terminals:** 300  $\Omega$  balanced  
75  $\Omega$  unbalanced

**Intermediate Frequency:** 10.7 MHz

**Sensitivity**  
**at 50 dB Quieting:** 4.0  $\mu$ V (MONO)  
50  $\mu$ V (STEREO)

**Sensitivity at 46 dB Quieting**  
**(40 kHz deviation):** 50  $\mu$ V (STEREO)

**Usable Sensitivity:** 2.0  $\mu$ V (IHF)  
1.7  $\mu$ V, S/N = 26 dB (40 kHz deviation)

**S/N Ratio:** 73 dB (MONO)  
68 dB (STEREO)

**Harmonic Distortion:**

at 100 Hz	0.2% (MONO)
	0.3% (STEREO)
at 1 kHz	0.2% (MONO)
	0.3% (STEREO)
at 10 kHz	0.2% (MONO)
	0.6% (STEREO)

**IM Distortion:** 0.2% (MONO)  
0.3% (STEREO)

**Separation:** 35 dB at 100 Hz  
40 dB at 1 kHz  
35 dB at 10 kHz

**Frequency Response:** 40 Hz – 12.5 kHz <sup>+0.5</sup> <sub>-1.5</sub> dB

#### Alternate

**Channel Selectivity:** 50 dB (400 kHz)

**Capture Ratio:** 1.0 dB

**AM Suppression Ratio:** 54 dB

**Image Response Ratio:** 45 dB

**IF Response Ratio:** 90 dB

**Spurious Response Ratio:** 75 dB

**RF Intermodulation:** 60 dB

**Sub-carrier Product Ratio:** 50 dB

**Muting Threshold:** Approx. 5  $\mu$ V

**Output Level/impedance:** 750 mV, 5 k $\Omega$  at  
100% modulation

# SONY®

---

# SERVICE MANUAL



# SECTION 1

## BLOCK DIAGRAM

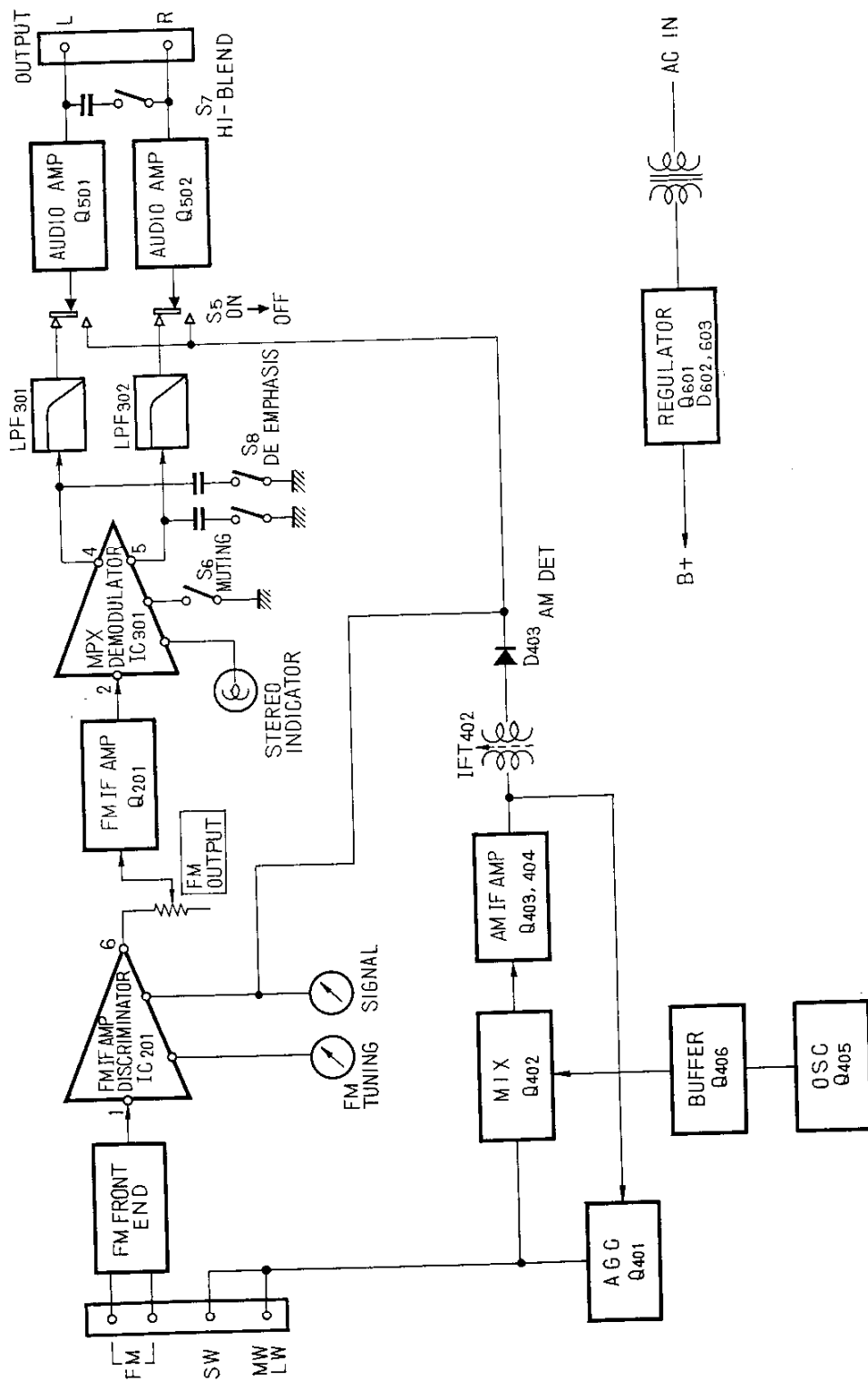

**SECTION 2  
DISASSEMBLY AND REPLACEMENT**

**1. ORNAMENTAL SIDE BOARD REMOVAL**

Remove four screws ( ⊕ BW 4 x 22) on the ornamental side boards (L, R).

**2. FRONT PANEL REMOVAL**

② BV 3 x 6  
(also at the bottom side)

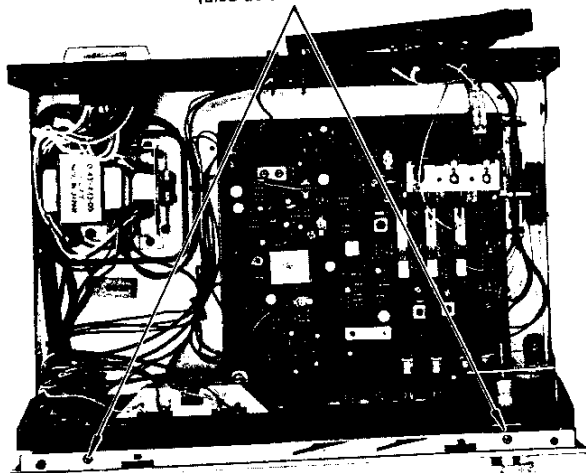

① Loosen the fixing screw and remove the knob.

**3. DIAL CORD STRINGING**

1) Dial Cord Preparation

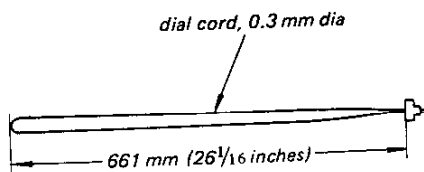

2) Dial Cord Stringing

Turn the tuning drum fully clockwise.

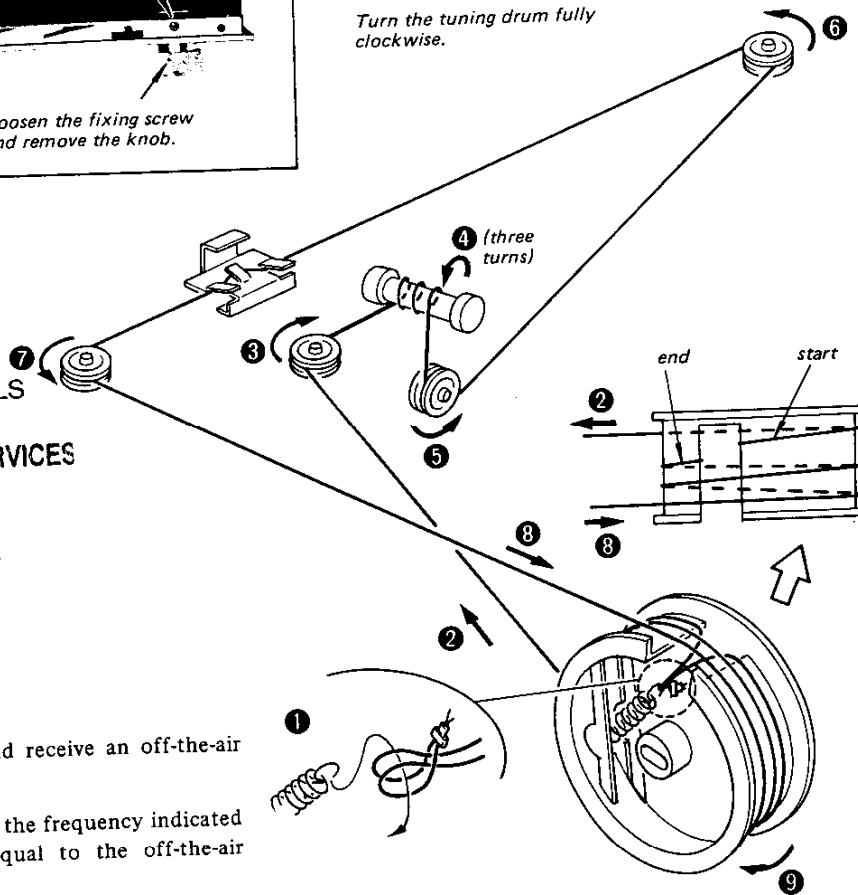

FOR SERVICE MANUALS  
CONTACT:  
**MAURITRON TECHNICAL SERVICES**  
www.mauritron.co.uk  
TEL: 01844 - 351694  
FAX: 01844 - 352554

3) Dial Pointer Setting

1. Turn the tuning drum and receive an off-the-air signal.
2. Set the dial pointer so that the frequency indicated by the dial pointer is equal to the off-the-air signal's carrier frequency.
3. Secure the dial cord and the dial pointer with locking compound.

# SECTION 3

## ALIGNMENTS AND ADJUSTMENTS

### FM FREQUENCY COVERAGE AND TRACKING ALIGNMENT

Never attempt alignment of the fm front-end section for the fm frequency coverage and tracking alignment. If the fm frequency coverage alignment is required, replace the fm front-end board.

In the case of tracking alignment, ask your nearest SONY Service Station to send your set to the Factory Service Center.

### LW/MW/SW FREQUENCY COVERAGE AND TRACKING ALIGNMENT

Setup:

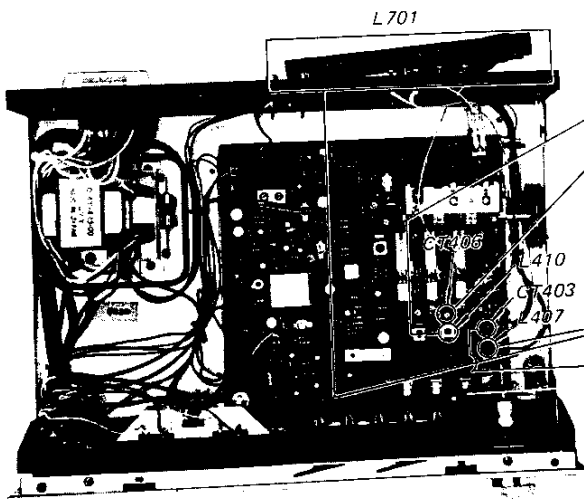
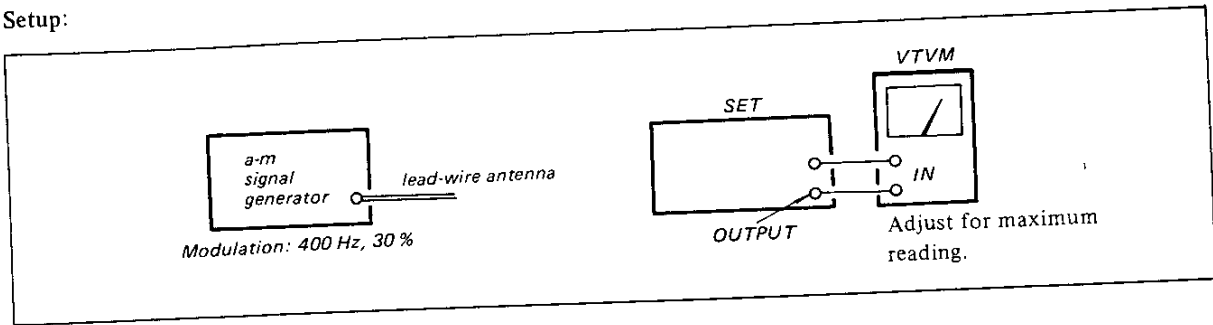

Step	LW FREQUENCY COVERAGE ALIGNMENT	DIAL INDICATION
1	L410 (150 kHz)	150 kHz
2	CT406 (350 kHz)	350 kHz

Note: Repeat step 1 and 2 several times, and finish the alignment at step 2.

Step	LW TRACKING ALIGNMENT
1	L407, 701 (150 kHz)
2	CT403 (300 kHz)

Note: Repeat step 1 and 2 several times, and finish the alignment at step 2.

FOR SERVICE MANUALS  
CONTACT:  
**MAURITRON TECHNICAL SERVICES**  
www.mauritron.co.uk  
TEL: 01844 - 351694  
FAX: 01844 - 352554

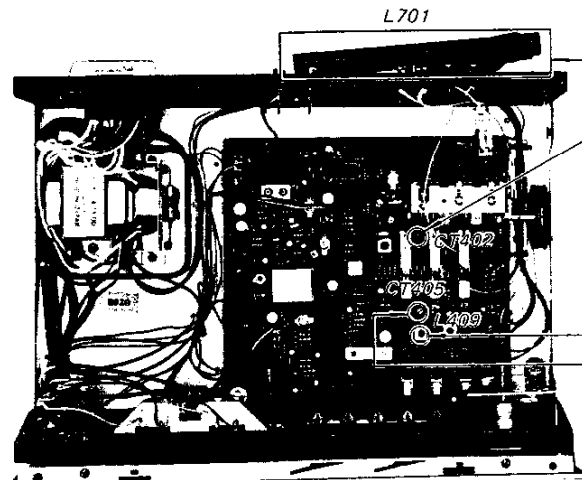

Step	MW TRACKING ALIGNMENT
1	L701 (600 kHz)
2	CT402 (1,400 kHz)

**Note:** Repeat step 1 and 2 several times, and finish the alignment at step 2.

Step	MW FREQUENCY COVERAGE ALIGNMENT
1	L409 (530 kHz)
2	CT405 (1,605 kHz)

**Note:** Repeat step 1 and 2 several times, and finish the alignment at step 2.

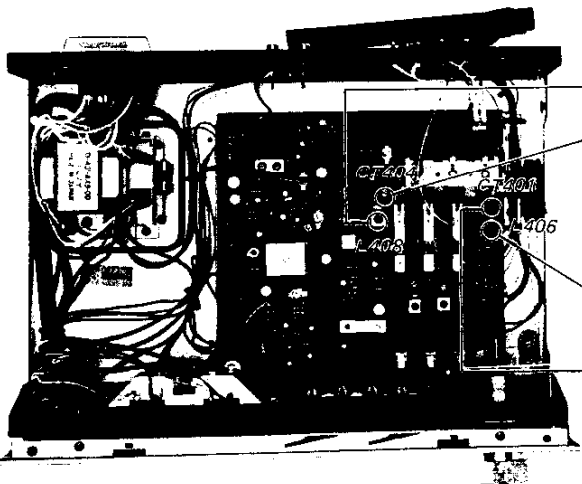

Step	SW FREQUENCY COVERAGE ALIGNMENT	DIAL INDICATION
1	L408 (6 MHz)	6 MHz
2	CT404 (18 MHz)	18 MHz

**Note:** Repeat step 1 and 2 several times, and finish the alignment at step 2.

Step	SW TRACKING ALIGNMENT
1	L406 (6 MHz)
2	CT401 (18 MHz)

**Note:** Repeat step 1 and 2 several times, and finish the alignment at step 2.

### FM IF ALIGNMENT

#### Setup:

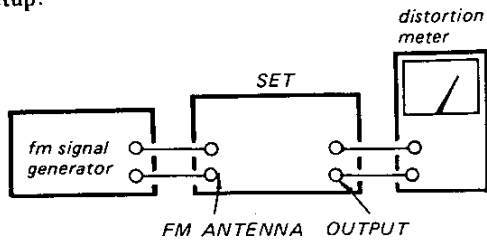

#### FM Signal Generator Setting:

Carrier frequency: 98 MHz  
 Modulation: 400 Hz,  
 75 kHz deviation (100%)  
 Output level: 1 mV (60 dB)

#### Procedure:

Tune the set to 98 MHz and adjust the primary-side core (black) of IFT201 for a minimum distortion reading.

### FM DISCRIMINATOR ALIGNMENT

#### Procedure:

1. Detune the set.
2. Turn the secondary-side core (blue) of IFT201 for null-point reading on the FM TUNING meter.

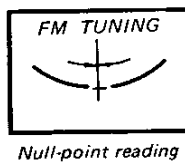

Null-point reading

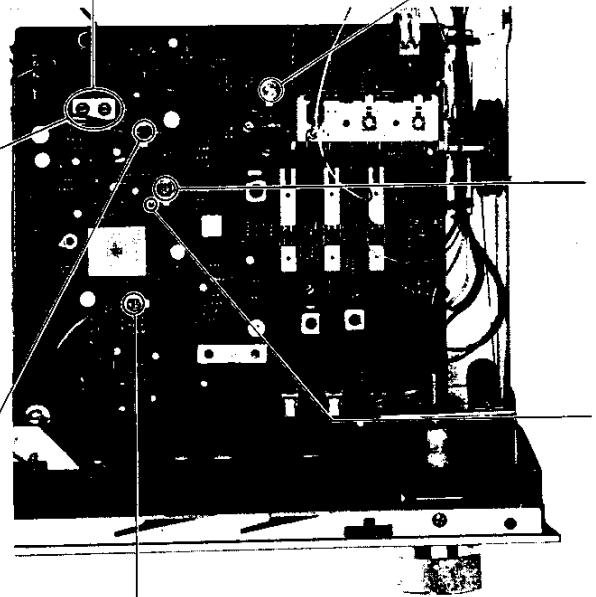

### FM OUTPUT LEVEL ADJUSTMENT

#### Setup:

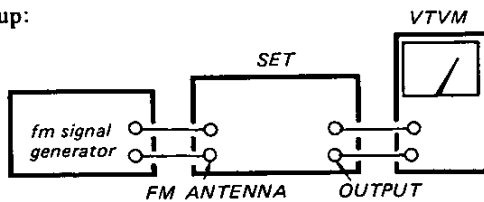

#### FM Signal Generator Setting:

Carrier frequency: 98 MHz,  
 Modulation: 400 Hz,  
 75 kHz deviation (100%)  
 Output level: 1 mV (60 dB)

#### Procedure:

Adjust RT202 for 750 mV (-0.3 dB) reading on the VTVM.

### FM STEREO SEPARATION ADJUSTMENT

#### Setup:

MUTING/MODE switch: ON/STEREO

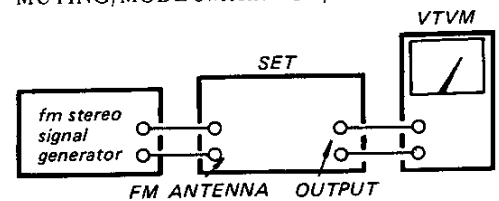

#### FM Stereo Signal Generator Setting:

Main carrier frequency: 98 MHz  
 Output level: 1 mV (60 dB)  
 Mode: Stereo  
 Audio (400 Hz) Mod: 67.5 kHz deviation (90  
 Pilot (19 kHz) Mod: 7.5 kHz deviation (10

### FM Signal Generator Setting:

Carrier frequency: 98 MHz  
 Modulation: 400 Hz,  
 75 kHz deviation (100%)  
 Output level: 1 mV (60 dB)

#### Procedure:

Tune the set to 98 MHz and adjust the primary-side core (black) of IFT201 for a minimum distortion reading.

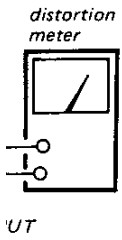

### SIGNAL METER ADJUSTMENT

#### Setup:

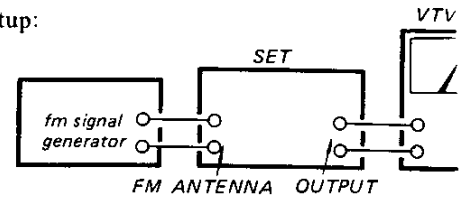

### FM Signal Generator Setting:

Carrier frequency: 98 MHz  
 Modulation: 400 Hz,  
 75 kHz deviation (100%)  
 Output level: 1 mV (60 dB)

### 19 kHz ADJUSTMENT

#### Setup:

MUTING/MODE switch: ON/STEREO

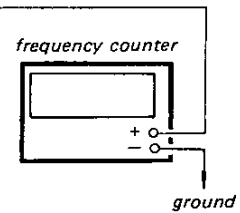
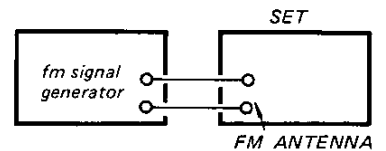

of IFT201 for  
 JNING meter.

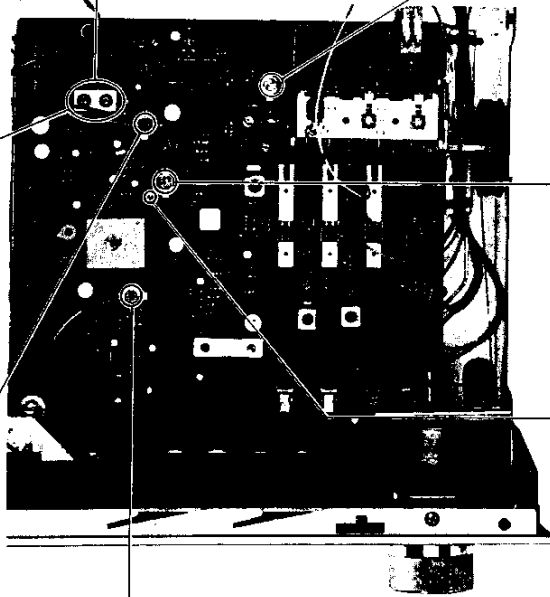

### FM STEREO SEPARATION ADJUSTMENT

#### Setup:

MUTING/MODE switch: ON/STEREO

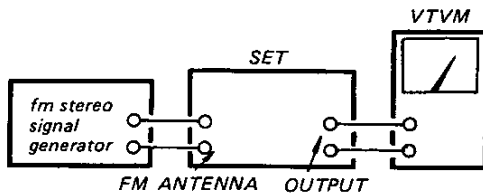

### FM Stereo Signal Generator Setting:

Main carrier frequency: 98 MHz  
 Output level: 1 mV (60 dB)  
 Mode: Stereo  
 Audio (400 Hz) Mod: 67.5 kHz deviation (90%)  
 Pilot (19 kHz) Mod: 7.5 kHz deviation (10%)

#### Procedure:

1. Set the signal generator channel selector to L-C
2. Tune the set to 98 MHz.
3. Connect the VTVM to the OUTPUT "L-CH" the set and calibrate the VTVM for 0 dB reading
4. Turn the stereo signal generator channel select from L-CH to R-CH and adjust RT501 for minimum output on the VTVM.
5. Connect the VTVM to the OUTPUT "R-CH" the set and calibrate the VTVM for 0 dB reading
6. Turn the stereo signal generator channel select from R-CH to L-CH and adjust RT501 for minimum output on the VTVM.

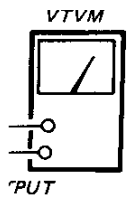

(100%)

ading on the

FOR SERVICE MANUALS

CONTACT:

MAURITRON TECHNICAL SERVICES

www.mauritron.co.uk

TEL: 01844 - 351694

FAX: 01844 - 352554



**SIGNAL METER ADJUSTMENT**

Setup:

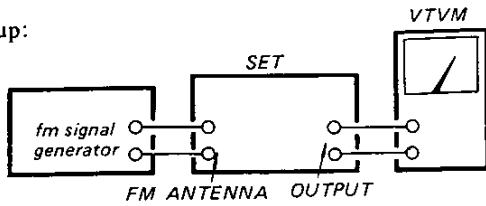

**FM Signal Generator Setting:**

- Carrier frequency: 98 MHz
- Modulation: 400 Hz,  
75 kHz deviation (100%)
- Output level: 1 mV (60 dB)

Procedure:

Tune the set to 98 MHz and adjust RT201 for specified pointer position (See figure below.) on the SIGNAL meter.

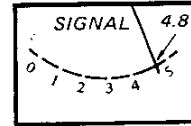

**19 kHz ADJUSTMENT**

Setup:

MUTING/MODE switch: ON/STEREO

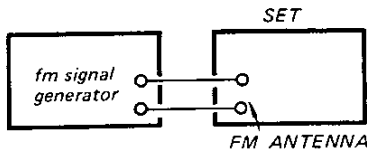

**FM Signal Generator Setting:**

- Carrier frequency: 98 MHz
- Modulation: 400 Hz,  
75 kHz deviation (100%)
- Output level: 1 mV (60 dB)

A) With Frequency Counter  
Procedure:

1. Tune the set to 98 MHz.
2. Adjust RT301 for 19 kHz  $\pm$  100 Hz on the counter.

B) Without Frequency Counter  
Procedure:

1. Tune the set to FM stereo signal.
2. Turn RT301 clockwise or counterclockwise and secure RT301 at the center in lighting-up range of stereo lamp as shown below.

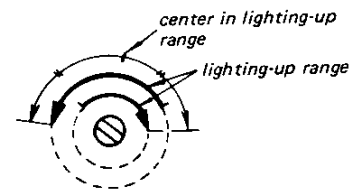

ENT

Procedure:

1. Set the signal generator channel selector to L-CH.
2. Tune the set to 98 MHz.
3. Connect the VTVM to the OUTPUT "L-CH" of the set and calibrate the VTVM for 0 dB reading.
4. Turn the stereo signal generator channel selector from L-CH to R-CH and adjust RT501 for minimum output on the VTVM.
5. Connect the VTVM to the OUTPUT "R-CH" of the set and calibrate the VTVM for 0 dB reading.
6. Turn the stereo signal generator channel selector from R-CH to L-CH and adjust RT501 for minimum output on the VTVM.

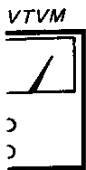

iation (90%)  
tion (10%)

FOR SERVICE MANUALS  
CONTACT:  
**MAURITRON TECHNICAL SERVICES**  
www.mauritron.co.uk  
TEL: 01844 - 351694  
FAX: 01844 - 352554

# SECTION 4 DIAGRAMS

## 4-1. MOUNTING DIAGRAM — Conductor Side —

IC201: HA1137

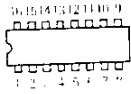

(Top view)

IC301: HA-1156

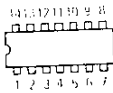

(Top view)

Q201  
Q501, 502: 2SC900

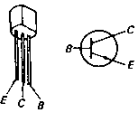

Q401 ~ 406: 2SC710

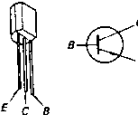

Q601: 2SC1173

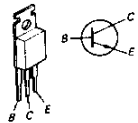

D201, 301: 1S1555

D401, 402

D202: 1T22A

D403

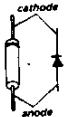

D602: 10E2

D603

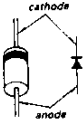

D601: EQA01-16R

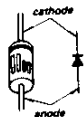

FOR SERVICE MANUALS  
CONTACT:  
**MAURITRON TECHNICAL SERVICES**  
www.mauritron.co.uk  
TEL: 01844 - 351694  
FAX: 01844 - 352554

Q, IC	D
IC201	
	202
	201
	301
	201
IC301	403
	402
	404
	405
	403
	501
	406
	602
	603
	502
	401
601	401
	601

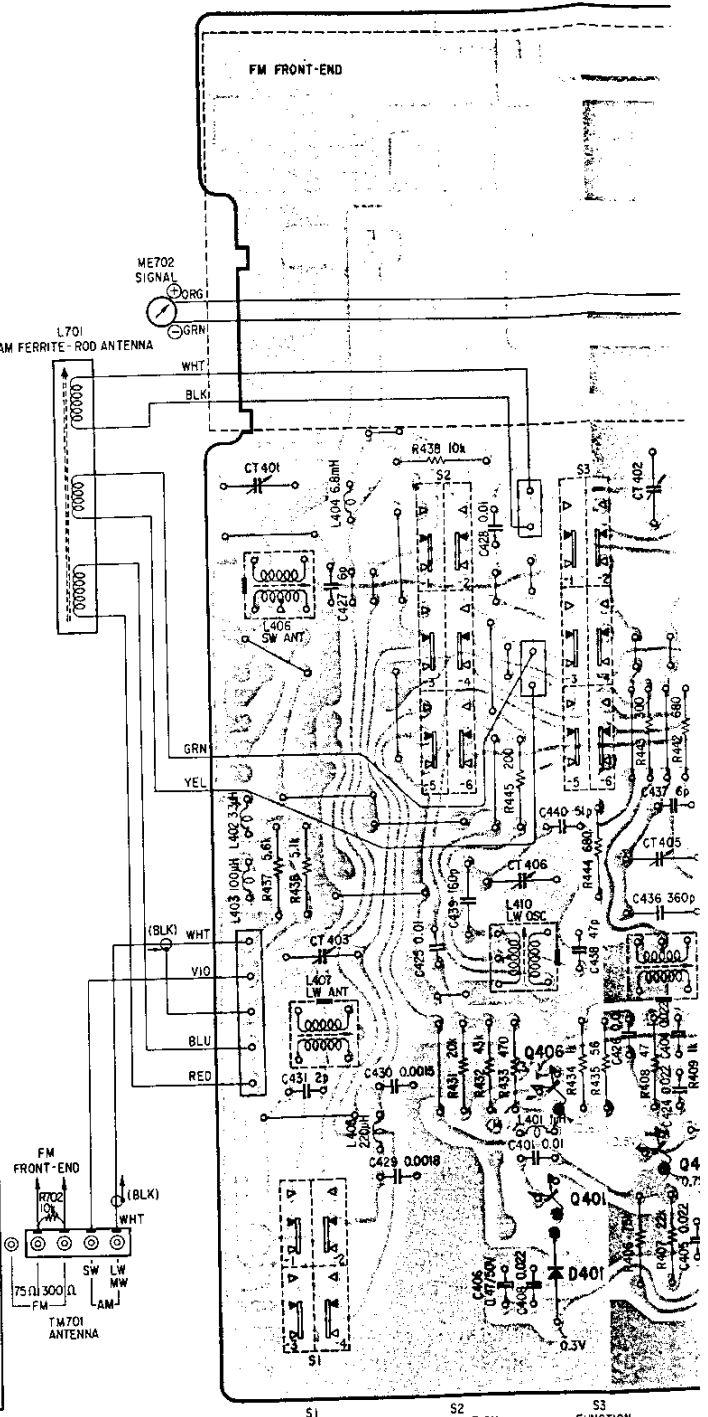

S1 ANTENNA SELECTOR  
EXT → BUILT IN

S2 FUNCTION (LW)  
ON → OFF

S3 FUNCTION (MW)  
ON → OFF

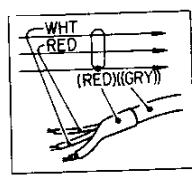

- Note:**
- shows the location of stencilled part number. Refer to this mark when replacing the parts.
  - Capacitors marked  $\Delta$  are built in transformers.
  - : Muting switch "ON".
  - : B+ pattern

SECTION 4  
DIAGRAMS

Q, IC	D
IC201	
202	
201	
301	
201	
IC301	
403	
402	
404	
405	
403	
501	
406	
602	
603	
502	
401	
601	401
601	601

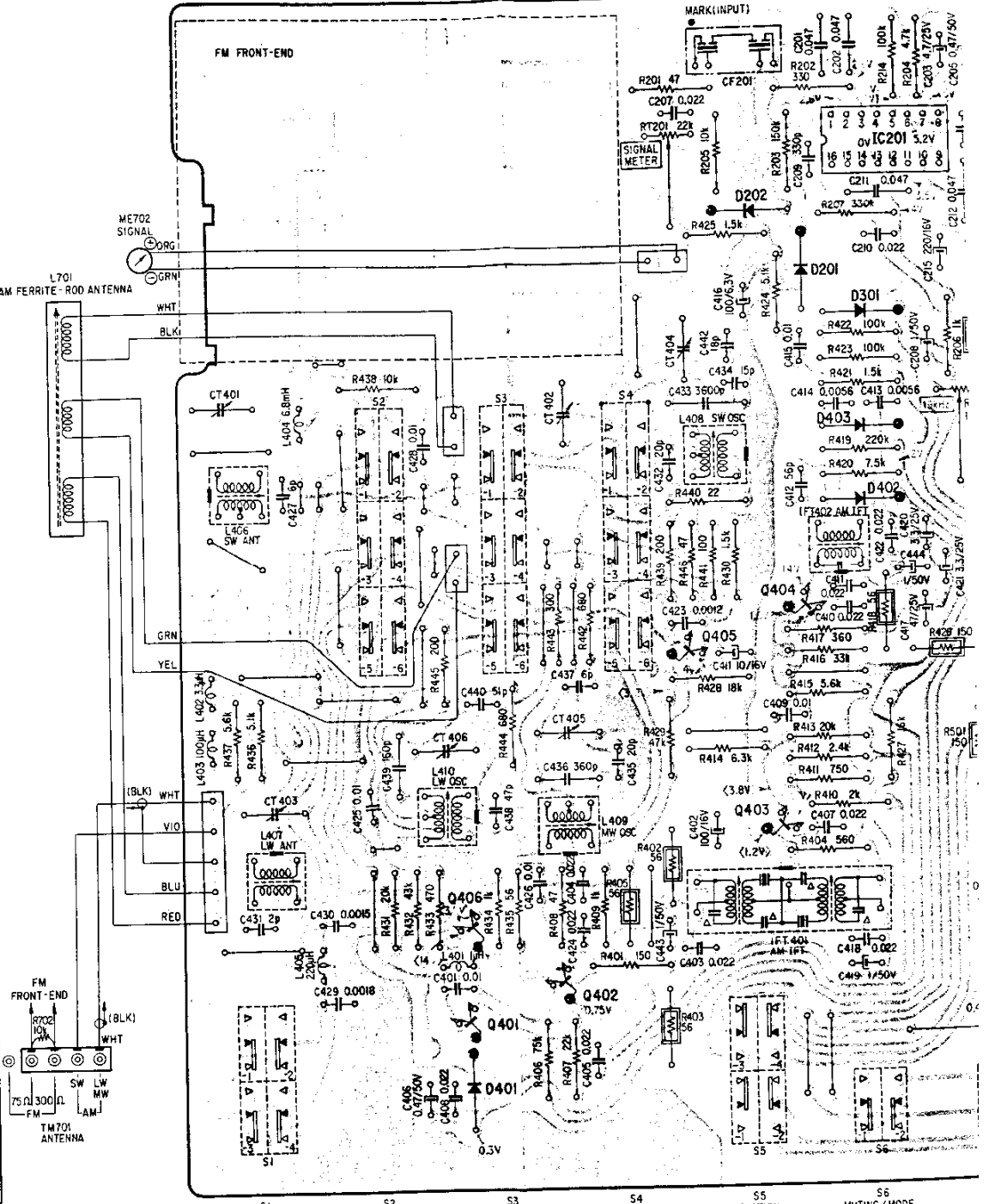

- S1 ANTENNA SELECTOR  
EXT BUILT IN
- S2 FUNCTION (LW)  
ON OFF
- S3 FUNCTION (MW)  
ON OFF
- S4 FUNCTION (SW)  
ON OFF
- S5 FUNCTION (FM)  
ON OFF
- S6 MUTING / MODE  
OFF MONO  
ON STEREO

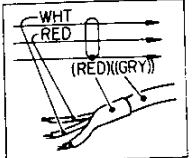

the location of stencilled part number.  
to this mark when replacing the parts.  
marked  $\Delta$  are built in transformers.  
ring switch "ON".  
pattern

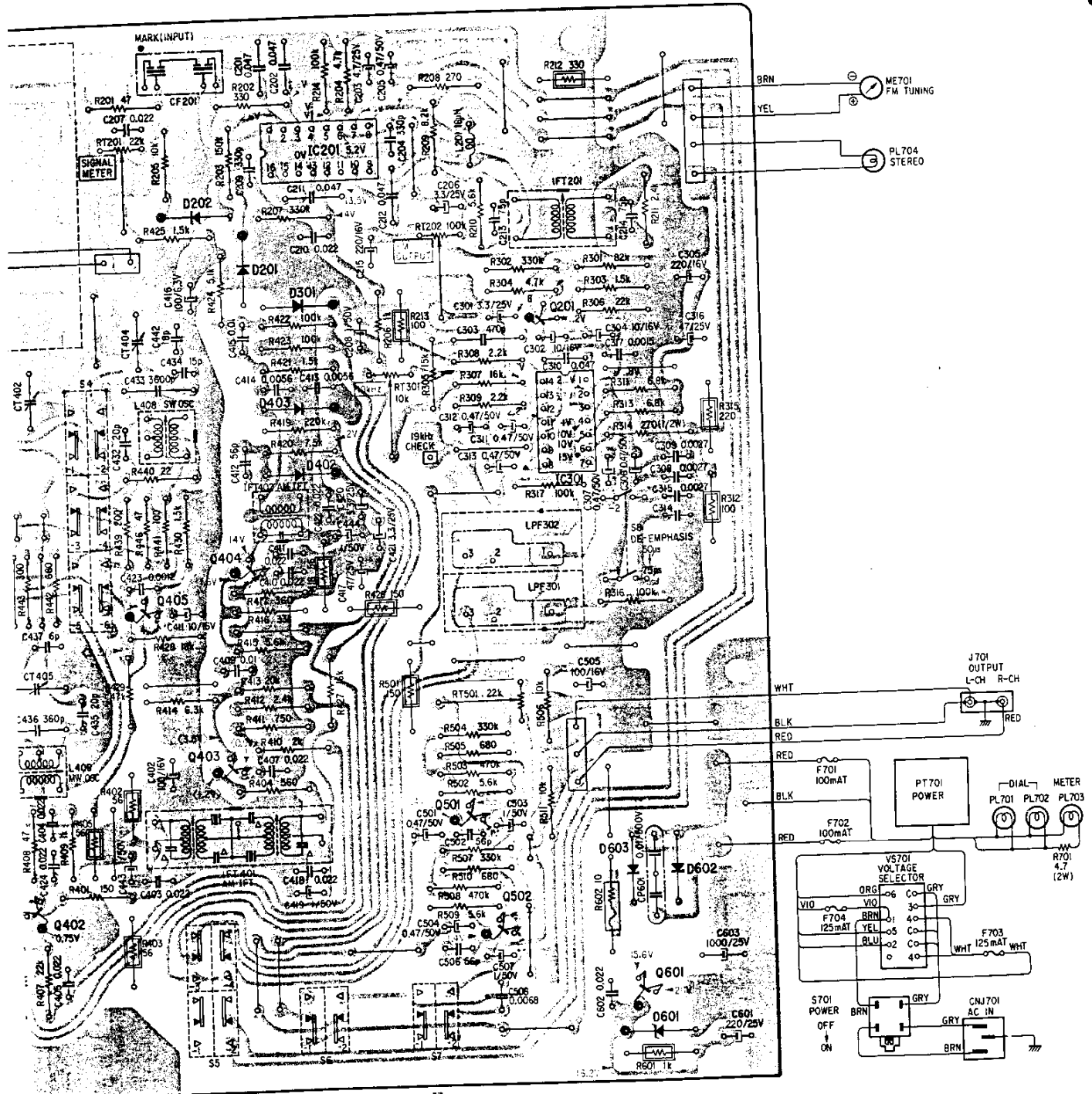

- S4 FUNCTION (SW) ON OFF
- S5 FUNCTION (FM) ON OFF
- S6 MUTING / MODE OFF MONO ON STEREO
- S7 HI-BLEND ON OFF

FOR SERVICE MANUALS  
CONTACT:  
**MAURITRON TECHNICAL SERVICES**  
www.mauritron.co.uk  
TEL: 01844 - 351694  
FAX: 01844 - 352554

# 4.2. SCHEMATIC DIAGRAM

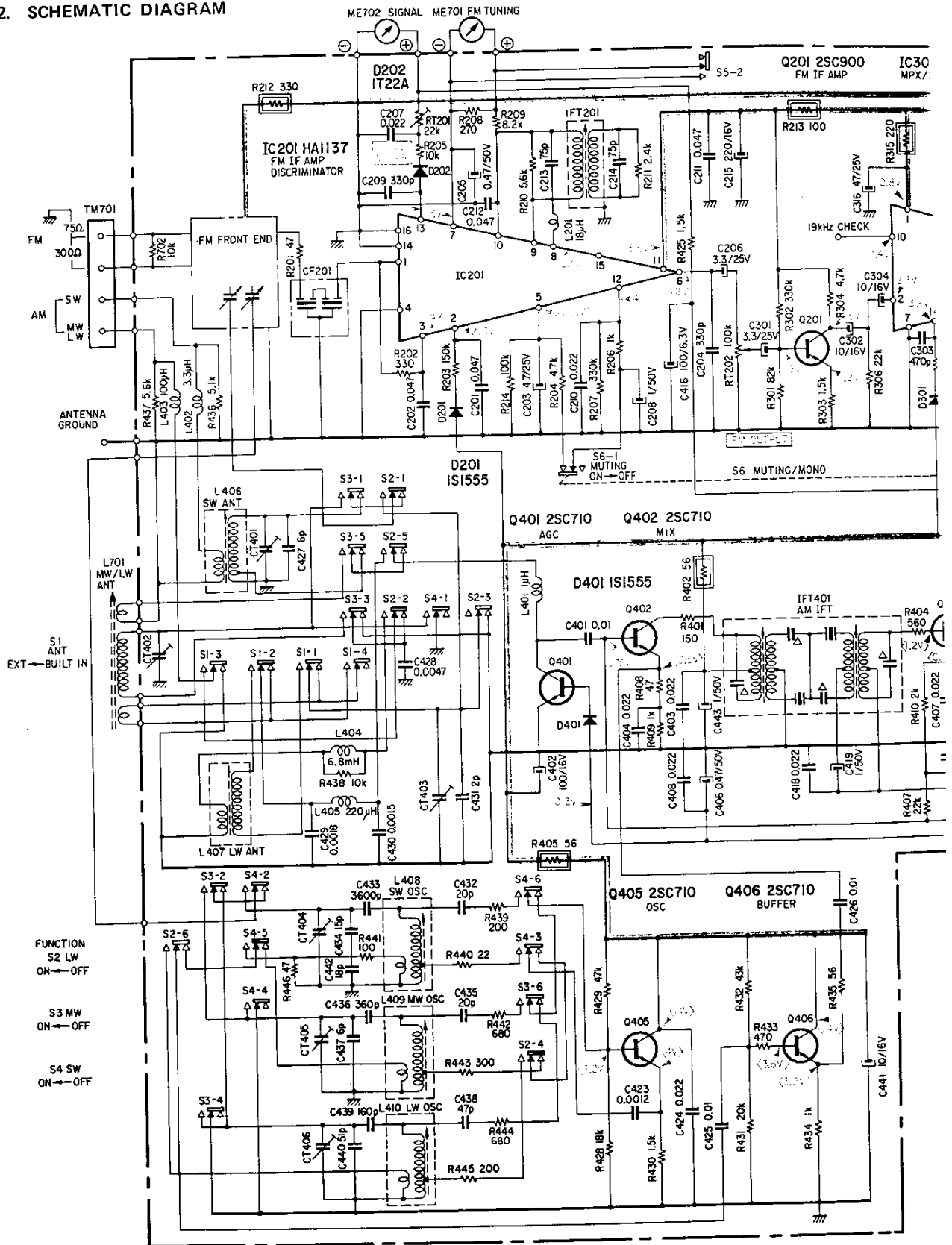

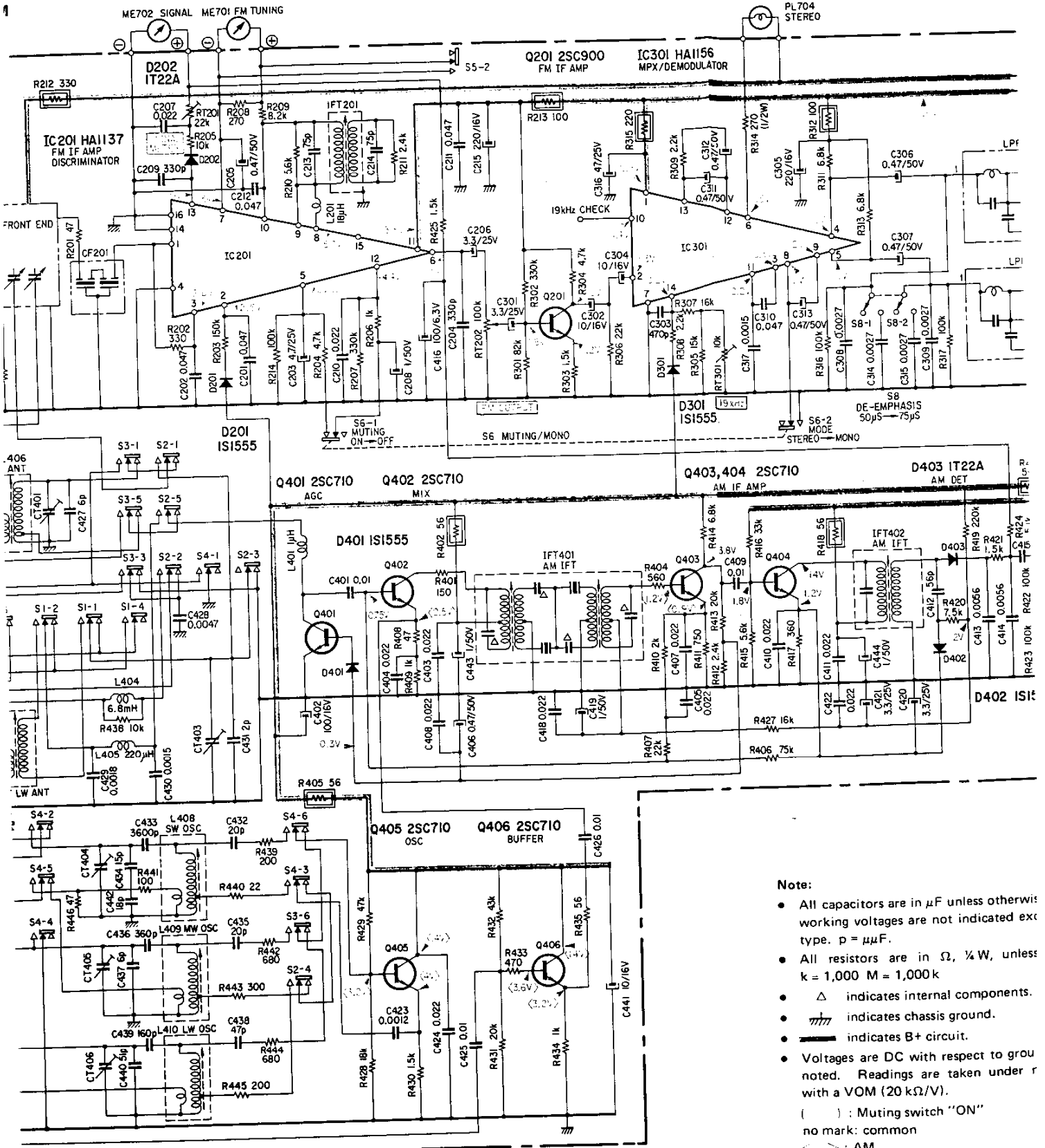

- Note:**
- All capacitors are in  $\mu\text{F}$  unless otherwise working voltages are not indicated except type.  $p = \mu\text{F}$ .
  - All resistors are in  $\Omega$ ,  $\frac{1}{2}W$ , unless  $k = 1,000$   $M = 1,000k$
  - $\Delta$  indicates internal components.
  - $\text{---}$  indicates chassis ground.
  - $\text{---}$  indicates B+ circuit.
  - Voltages are DC with respect to ground noted. Readings are taken under r with a VOM (20  $k\Omega/V$ ).
  - ( ) : Muting switch "ON"  
no mark: common  
< > : AM
  - Voltage variations may be noted due to component tolerances.

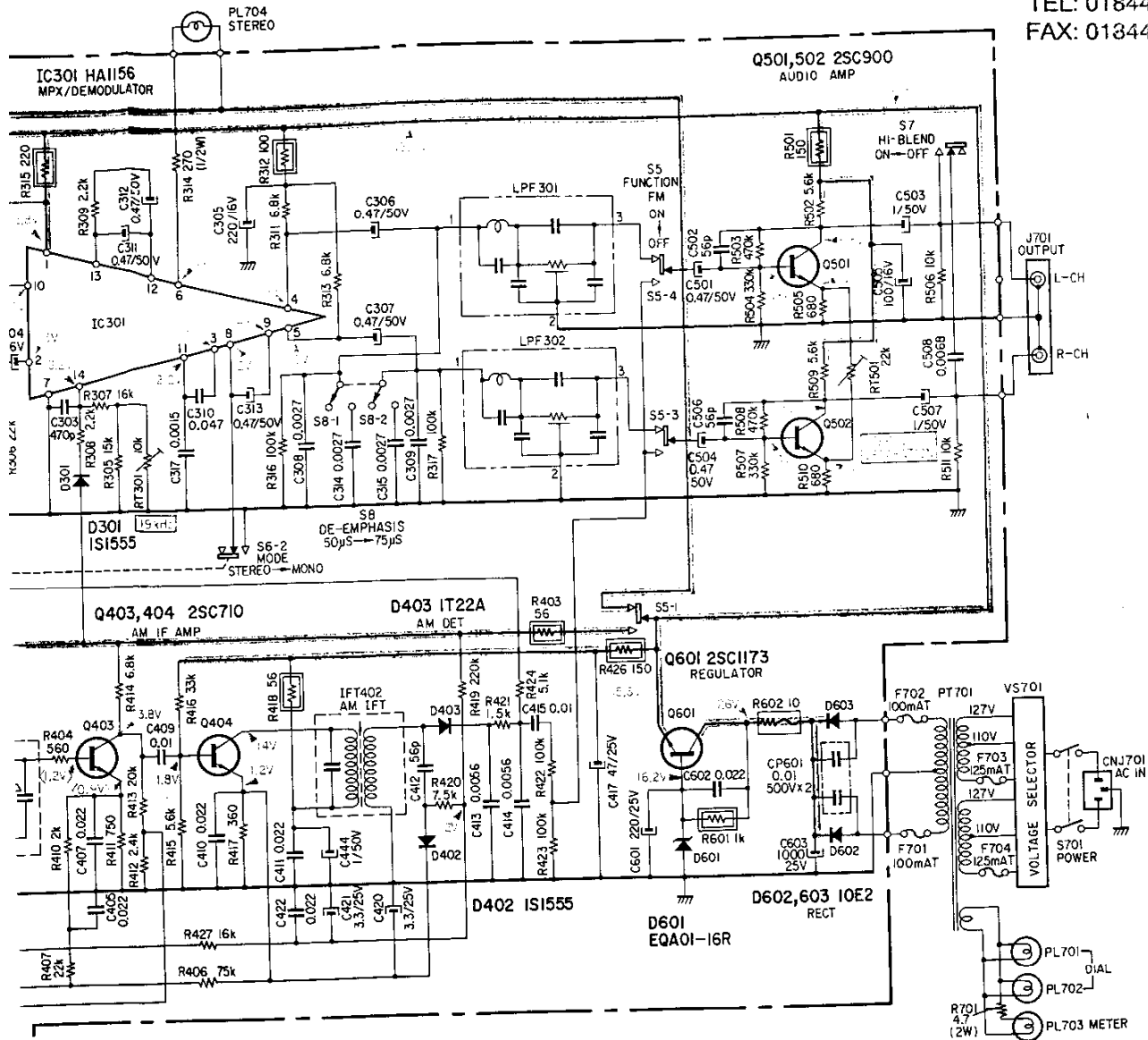

**Note:**

- All capacitors are in  $\mu\text{F}$  unless otherwise noted. 50 or less working voltages are not indicated except for electrolytic type.  $p = \mu\text{F}$ .
- All resistors are in  $\Omega$ ,  $\frac{1}{4}\text{W}$ , unless otherwise noted.  $k = 1,000$   $M = 1,000k$
- $\Delta$  indicates internal components.
- $\text{///}$  indicates chassis ground.
- $\text{---}$  indicates B+ circuit.
- Voltages are DC with respect to ground unless otherwise noted. Readings are taken under no-signal conditions with a VOM (20  $k\Omega/V$ ).
- ( ) : Muting switch "ON"
- no mark: common
- < > : AM
- Voltage variations may be noted due to normal production tolerances.

• indicates nonflammable resistor.

• indicates fusible resistor.

• Switch Mode:

Ref. No.	Description	Position
S1	ANT (MW/LW only)	BUILT IN
S2	LW	FUNCTION
S3	MW	
S4	SW	
S5	FM	
S6	MUTING MODE	ON STEREO
S7	HI-BLEND	OFF
S8	DE-EMPHASIS	50 $\mu\text{S}$
S701	POWER	OFF





# SECTION 5 EXPLODED VIEWS

B

C

D

E

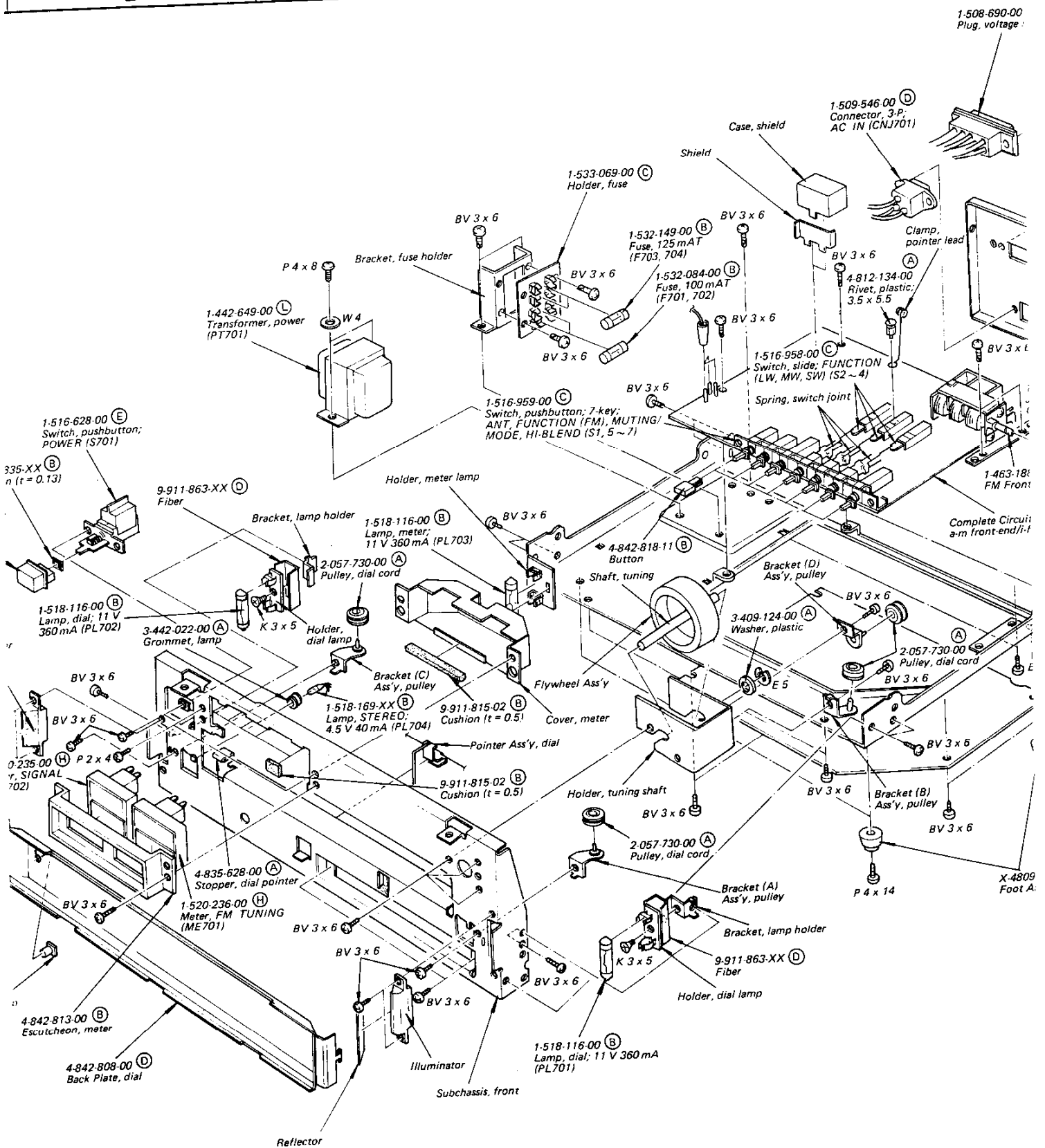



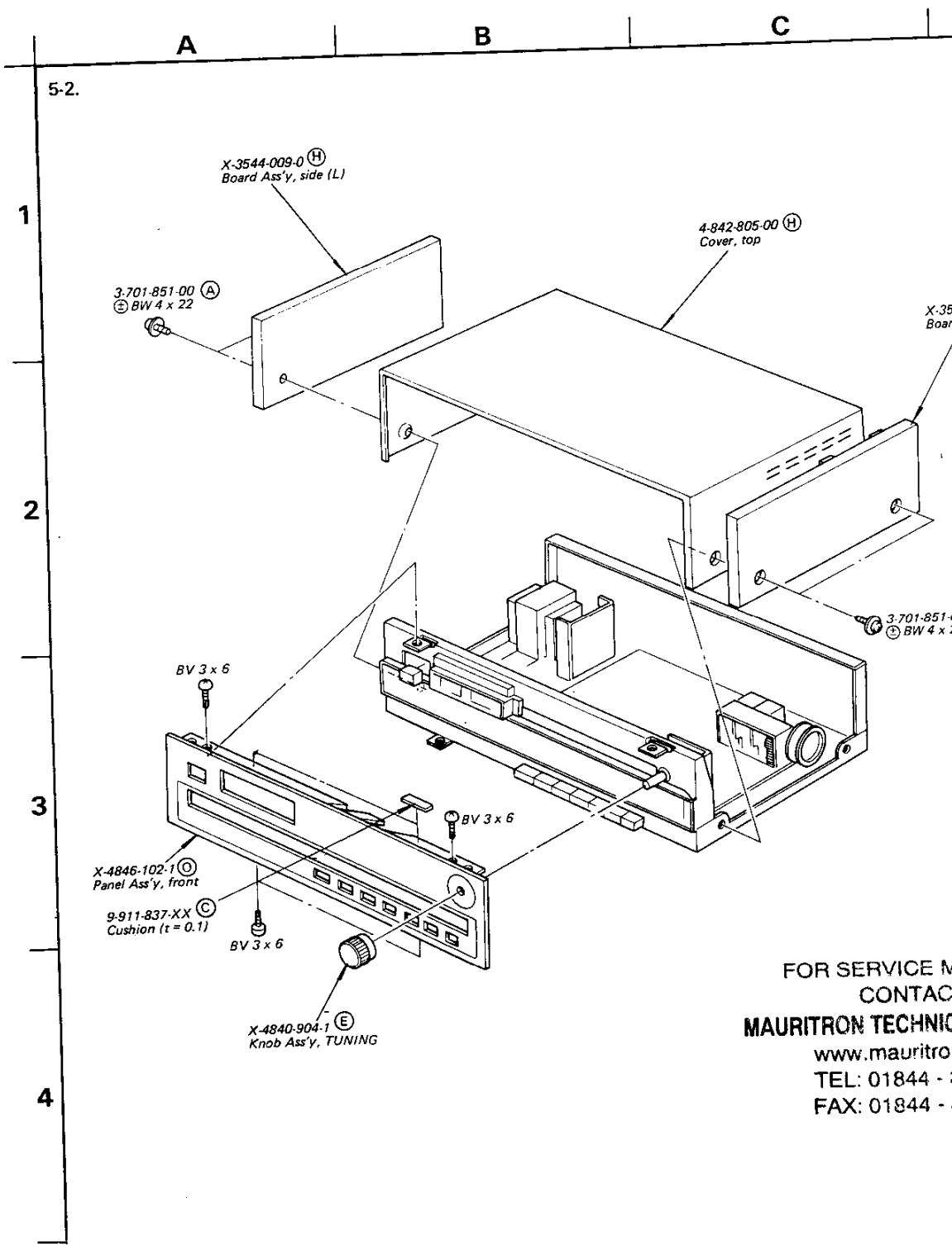

FOR SERVICE MANUALS  
CONTACT:  
**MAURITRON TECHNICAL SERVICES**  
www.mauritron.co.uk  
TEL: 01844 - 351694  
FAX: 01844 - 352554

- Note:**
- Items with no part number and/or no description are not stocked because they are seldom required for routine service.
  - All screws are Phillips (cross recess) type unless otherwise noted.  
(-) = slotted head
  - The circled letters ( A to Z ) are applicable for European model only.

**SECTION 6  
ELECTRICAL PARTS LIST**

Note: The circled letters (A) to (Z) are applicable for European model only.

<u>Ref. No.</u>	<u>Part No.</u>	<u>Description</u>
<b>SEMICONDUCTORS</b>		
<b>Transistors</b>		
⇒ Q201	(B) 2SC632A	
Q401 ~ 406	(B) 2SC710	
⇒ Q501, 502	(B) 2SC632A	
Q601	(C) 2SC1173	
<b>ICs</b>		
IC201	(H) HA1137	
⇒ IC301	(J) HA1156W	
<b>Diodes</b>		
D201	(B) 1S1555	
D202	(B) 1T22A	
D301	(B) 1S1555	
D401, 402	(B) 1S1555	
D403	(B) 1T22A	
D601	(C) EQA01-16R	
D602, 603	(B) 10E2	
<b>COILS</b>		
L401	1-407-178-XX (A) Microinductor, 1 μH	
L402	1-407-184-XX (A) Microinductor, 3.3 μH	
L403	1-407-169-XX (A) Microinductor, 100 μH	
L404	1-407-204-XX (B) Microinductor, 6.8 mH	
L405	1-407-173-XX (A) Microinductor, 220 μH	
L406	1-401-663-00 (B) SW Ant	
L407	1-401-664-00 (B) LW Ant	
L408	1-405-730-00 (B) SW Osc	
L409	1-405-732-00 (B) MW Osc	
L410	1-405-731-00 (B) LW Osc	
L701	1-401-669-00 (H) MW/LW Ferrite-rod Ant	

⇒: Due to replacement parts, the descriptions are different from the diagrams.

<u>Ref. No.</u>	<u>Part No.</u>	<u>Description</u>
<b>TRANSFORMERS</b>		
IFT201	1-404-029-00 (C) FM Discriminator	
IFT401	1-403-963-21 (E) AM IFT	
IFT402	1-403-149-00 (B) AM IFT	
PT701	1-442-649-00 (L) Power	
<b>FILTERS</b>		
CF201	1-527-240-91 (E) Ceramic	
LPF <sup>(301)</sup> <sub>(302)</sub>	1-231-303-00 (C) Low-pass	
<b>CAPACITORS</b>		
All capacitors are in μF and of ceramic unless otherwise noted. (p = μμ, elect = electrolytic) 50 or less working volts are omitted except for electrolytic type.		
C201, 202	1-101-925-11 (A) 0.047	
C203	1-121-395-11 (A) 4.7	25 V elect
C204	1-102-112-11 (A) 330 p	
C205	1-121-726-11 (A) 0.47	50 V elect
C206	1-121-392-11 (A) 3.3	25 V elect
C207	1-101-924-11 (A) 0.022	
C208	1-121-391-11 (A) 1	50 V elect
C209	1-102-112-11 (A) 330 p	
C210	1-101-924-11 (A) 0.022	
C211, 212	1-101-925-11 (A) 0.047	
C213, 214	1-102-732-11 (A) 75 p	
C215	1-121-421-11 (B) 220	16 V elect
C301	1-121-392-11 (A) 3.3	25 V elect
C302	1-121-651-11 (A) 10	16 V elect
C303	1-103-717-11 (A) 470 p	polystyrol
C304	1-121-651-11 (A) 10	16 V elect
C305	1-121-421-11 (B) 220	16 V elect
C306, 307	1-121-726-11 (A) 0.47	50 V elect
C308, 309	1-108-830-12 (A) 0.0027	mylar
C310	1-108-845-12 (A) 0.047	mylar
C311 ~ 313	1-121-726-11 (A) 0.47	50 V elect
C314, 315	1-108-830-12 (A) 0.0027	mylar

FOR SERVICE MANUALS  
CONTACT:  
**MAURITRON TECHNICAL SERVICES**  
www.mauritron.co.uk  
TEL: 01844 - 351664  
FAX: 01844 - 352554

Note: The circled letters ( A to Z ) are applicable for European model only.

<u>Ref. No.</u>	<u>Part No.</u>	<u>Description</u>
C316	1-121-410-11	(B) 47 25 V elect
C317	1-108-827-12	(A) 0.0015 mylar
C401	1-101-923-11	(A) 0.01
C402	1-121-415-11	(B) 100 16 V elect
C403 ~ 405	1-101-924-11	(A) 0.022
C406	1-121-726-11	(A) 0.47 50 V elect
C407, 408	1-101-924-11	(A) 0.022
C409	1-101-923-11	(A) 0.01
C410, 411	1-101-924-11	(A) 0.022
C412	1-101-884-11	(A) 56 p
C413, 414	1-108-834-12	(A) 0.0056 mylar
C415	1-108-837-12	(A) 0.01 mylar
C416	1-121-413-11	(A) 100 6.3 V elect
C417	1-121-410-11	(B) 47 25 V elect
C418	1-101-924-11	(A) 0.022
C419	1-121-391-11	(A) 1 50 V elect
C420, 421	1-121-392-11	(A) 3.3 25 V elect
C422	1-101-924-11	(A) 0.022
C423	1-108-826-12	(A) 0.0012 mylar
C424	1-101-924-11	(A) 0.022
C425, 426	1-101-923-11	(A) 0.01
C427	1-102-943-11	(A) 6 p
C428	1-108-833-12	(A) 0.0047
C429	1-108-828-12	(A) 0.0018 mylar
C430	1-108-827-12	(A) 0.0015 mylar
C431	1-102-939-11	(A) 2 p
C432	1-102-958-11	(A) 20 p
C433	1-103-738-11	(A) 3600 p polystyrol
C434	1-102-292-11	(A) 15 p
C435	1-102-958-11	(A) 20 p
C436	1-103-714-11	(A) 360 p polystyrol
C437	1-102-943-11	(A) 6 p
C438	1-101-880-11	(A) 47 p
C439	1-103-706-11	(A) 160 p polystyrol
C440	1-101-882-11	(A) 51 p
C441	1-121-651-11	(A) 10 16 V elect
C442	1-102-296-11	(A) 18 p
C443, 444	1-121-391-11	(A) 1 50 V elect
C501	1-121-726-11	(A) 0.47 50 V elect
C502	1-101-884-11	(A) 56 p
C503	1-121-391-11	(A) 1 50 V elect
C504	1-121-726-11	(A) 0.47 50 V elect
C505	1-121-415-11	(B) 100 16 V elect

<u>Ref. No.</u>	<u>Part No.</u>	<u>Description</u>
C506	1-101-884-11	(A) 56 p
C507	1-121-391-11	(A) 1 50 V elect
C508	1-108-835-12	(A) 0.0068 mylar
C601	1-121-422-11	(B) 220 25 V elect
C602	1-108-841-12	(A) 0.022 mylar
C603	1-121-657-11	(B) 1000 25 V elect
CP601	1-102-355-11	(A) (0.01 500 V) x 2 ceramic
CT401, 403	1-141-147-00	(B) Trimmer
CT405, 406		(B) Trimmer
CT402, 404	1-141-138-XX	(B) Trimmer

### RESISTORS

All resistor are in  $\Omega$ . Regular-type  $\frac{1}{4}W$  carbon resistors are omitted. Check the schematic diagram for the resistance values. (k = 1000)

R212	1-211-534-11	(A) 330 $\frac{1}{4}W$ carbon (nonflammable)
R213	1-211-522-11	(A) 100 $\frac{1}{4}W$ carbon (nonflammable)
R312	1-211-522-11	(A) 100 $\frac{1}{4}W$ carbon (nonflammable)
R314	1-202-559-11	(A) 270 $\frac{1}{2}W$ composition
R315	1-211-530-11	(A) 220 $\frac{1}{4}W$ carbon (nonflammable)
R402, 403	1-211-516-11	(A) 56 $\frac{1}{4}W$ carbon (nonflammable)
R405, 418		(A) 56 $\frac{1}{4}W$ carbon (nonflammable)
R426	1-211-526-11	(A) 150 $\frac{1}{4}W$ carbon (nonflammable)
R501	1-211-526-11	(A) 150 $\frac{1}{4}W$ carbon (nonflammable)
R601	1-211-935-11	(A) 1 k $\frac{1}{4}W$ carbon (nonflammable)
R602	1-217-523-11	(A) 10 $\frac{1}{4}W$ fusible
R701	1-207-624-11	(B) 4.7 2 W wirewound
RT201	1-222-764-11	(A) 22 k, adjustable
RT202	1-222-766-11	(B) 100 k, adjustable
RT301	1-222-752-11	(B) 10 k, adjustable
RT501	1-222-764-11	(A) 22 k, adjustable

Note: The circled letters (A to Z) are applicable for European model only.

Ref. No.	Part No.	Description
<b>SWITCHES</b>		
S1, 5~7	1-516-959-00	(H) Pushbutton, 7-key; ANT, FUNCTION (FM), MUTING/MODE, HI-BLEND
S2~4	1-516-958-00	(C) Slide, FUNCTION (LW, MW, SW)
S8	1-516-954-00	(B) De-emphasis
S701	1-516-628-00	(E) Pushbutton, POWER

<b>MISCELLANEOUS</b>		
CNJ701	1-509-546-00	(D) Connector, 3-p; AC IN
F701, 702	1-532-084-00	(B) Fuse, 100 mA T
F703, 704	1-532-149-00	(B) Fuse, 125 mA T
J701	1-507-378-00	(B) Jack, phono; 2-p; OUTPUT
ME701	1-520-236-00	(H) Meter, FM TUNING
ME702	1-520-235-00	(H) Meter, SIGNAL
PL701~703	1-518-116-00	(B) Lamp, 11 V 360 mA; dial, meter

Ref. No.	Part No.	Description
PL704	1-518-169-XX	(B) Lamp, 4.5 V 40 mA; STEREO
TM701	1-536-403-00	(C) Terminal Strip, 4-p; ANTENNA
	1-463-188-21	(H) FM Front-end
	1-508-690-00	(C) Plug, voltage selector
	1-533-069-00	(C) Holder, fuse

<b>ACCESSORIES</b>	
Part No.	Description
X-4490-002-2	(B) Cloth Ass'y, polishing
1-501-161-00	(F) Ribbon Antenna, f-m
1-534-049-61	(F) Cord, connection; RK-74
1-534-492-00	(C) Cord, SW antenna
1-534-819-00	(C) Cord, power (UK Model)
3-780-970-11	(E) Manual, instruction

**HARDWARE NOMENCLATURE**

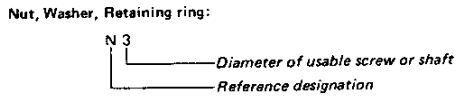
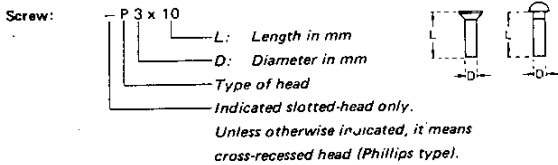

Reference Designation	Shape	Description	Remarks
<b>SCREWS</b>			
P		pan-head screw	binding-head (B) screw for replacement
PWH		pan-head screw with washer face	binding-head (B) screw and flat washer for replacement
PS PSP		pan-head screw with spring washer	binding-head (B) screw and spring washer for replacement
PSW PSPW		pan-head screw with spring and flat washers	binding-head (B) screw and spring and flat washers for replacement
R		round-head screw	binding-head (B) screw for replacement
K		flat-countersunk-head screw	
RK		oval-countersunk-head screw	
B		binding-head screw	
T		truss-head screw	binding-head (B) screw for replacement
F		flat-fillister-head screw	
RF		fillister-head screw	
BV		braizer-head screw	

Reference Designation	Shape	Description	Remarks
<b>SELF-TAPPING SCREWS</b>			
TA		self-tapping screw	ex: TA, P 3 x 10
PTP		pan-head self-tapping screw	binding-head self-tapping (TA, B) screw for replacement
PTPWH		pan-head self-tapping screw with washer face	binding-head self-tapping (TA, B) screw and flat washer for replacement
P <sup>T</sup> TWH		pan-head thread-rolling screw with washer face	binding-head (B) screw and flat washer for replacement
<b>SET SCREWS</b>			
SC		set screw	
SC		hexagon-socket set screw	ex: SC 2.6 x 4, hexagon socket
<b>NUT</b>			
N		nut	
<b>WASHERS</b>			
W		flat washer	
SW		spring washer	
LW		internal-tooth lock washer	ex: LW3, internal
LW		external-tooth lock washer	ex: LW3, external
<b>RETAINING RINGS</b>			
E		retaining ring	
G		grip-type retaining ring	
<b>FOR SERVICE MANUALS CONTACT:</b>			
<b>MAURITRON TECHNICAL SERVICES</b>			
www.mauritron.co.uk			
TEL: 01844 - 351694			
FAX: 01844 - 352554			

Sony Corporation

9-958-319-01

© 1976

6C0561-1

Printed in Japan