

SONY[®]

ST - A6B

Tuner



**new circuit
operation**

SONY INDUSTRIES

Hi-Fi Technical Support

47-47 Van Dam Street, Long Island City, New York 11101

PRINTED IN U.S.A.

IF Bandwidth Control

The ST-A6B offers a choice of IF bandwidth, or degree of selectivity, appropriate to the condition of the received signal. Narrow selectivity can be manually selected for the highest possible S/N ratio, or if a strong signal on an adjacent channel is causing interference. On the other hand, automatic selectivity selection can be chosen; the tuner itself will then select a bandwidth appropriate to the signal level.

Transistors Q201-Q204 are connected as cascaded pairs of emitter follower-common base amplifiers (Fig. 1). This configuration is akin to a differential amplifier having only one input driven. These amplifiers provide the extra gain needed to overcome ceramic filter losses, and improve limiting. An interesting feature of this amplifier block is that one bias-divider string (resistors R206 and R207) serves all four transistors.

Transistors Q203 and Q204 also play a part in the dual-bandwidth circuit. For normal selectivity (wide bandwidth), signal is channelled directly from the collector of Q203 to the input (pin 1) of IC201. For narrow bandwidth, signal is channelled through ceramic filters CF203 and CF204. Bandwidth selection and switching is accomplished by transistors Q205 and Q206, and diodes D201 and D202.

Narrow bandwidth operation can be selected either manually via the SELECTIVITY switch or automatically via the muting circuit. If the SELECTIVITY switch is set to NARROW, B+ is removed from resistor R241, so transistor Q205 has no base bias. Its collector-emitter impedance therefore becomes an open circuit and its collector voltage goes high. This forward biases diode D201, connecting the narrow-band signal (from CF204) to IC201, and turns on transistors Q206 and Q211. When saturated on, the collector-emitter im-

pedance of Q206 is so low that it shorts the direct signal (from Q203) to ground. The resulting near-zero collector voltage of Q206 kills the bias on diode D202, thereby opening the signal path from Q203 to IC201. Similarly, when saturated on, the resulting low collector-emitter impedance of Q211 completes the ground path for the NARROW lamp, turning it on. The low collector voltage of Q211 also turns off Q212 and the NORMAL lamp.

When the SELECTIVITY switch is set to AUTO, bandwidth selection is matched to received signal level under the control of the muting circuit. The muting control signal appearing at the variable contact of pot RT401 is also applied to transistor Q209 through resistor R237. Transistors Q209 and Q210 form a Schmitt trigger, so when the muting voltage exceeds a certain level, or falls below a lower level, the trigger output voltage will switch abruptly from one state to the other. The difference in trigger levels (hysteresis) ensures that the tuner will not rapidly switch back and forth between the two selectivity modes due to minor signal-level variations.

At low signal levels, the voltage delivered to Q209 will be too low to turn it on, hence the collector voltage of Q210 will be low and the conditions previously described for narrow-band operation will exist. However, if the signal is high enough for low-noise wideband operation, the high muting voltage will turn Q209 on and Q210 off. The resulting high Q210 collector voltage will bias Q205 into saturation, shorting the output of filter CF204. Transistor Q205's collector voltage will also drop to near zero, killing the bias on transistor Q206. This last action removes the short from the direct line, and the rise of Q206's collector voltage causes diode D202 to conduct and connect the wideband signal path to IC201.

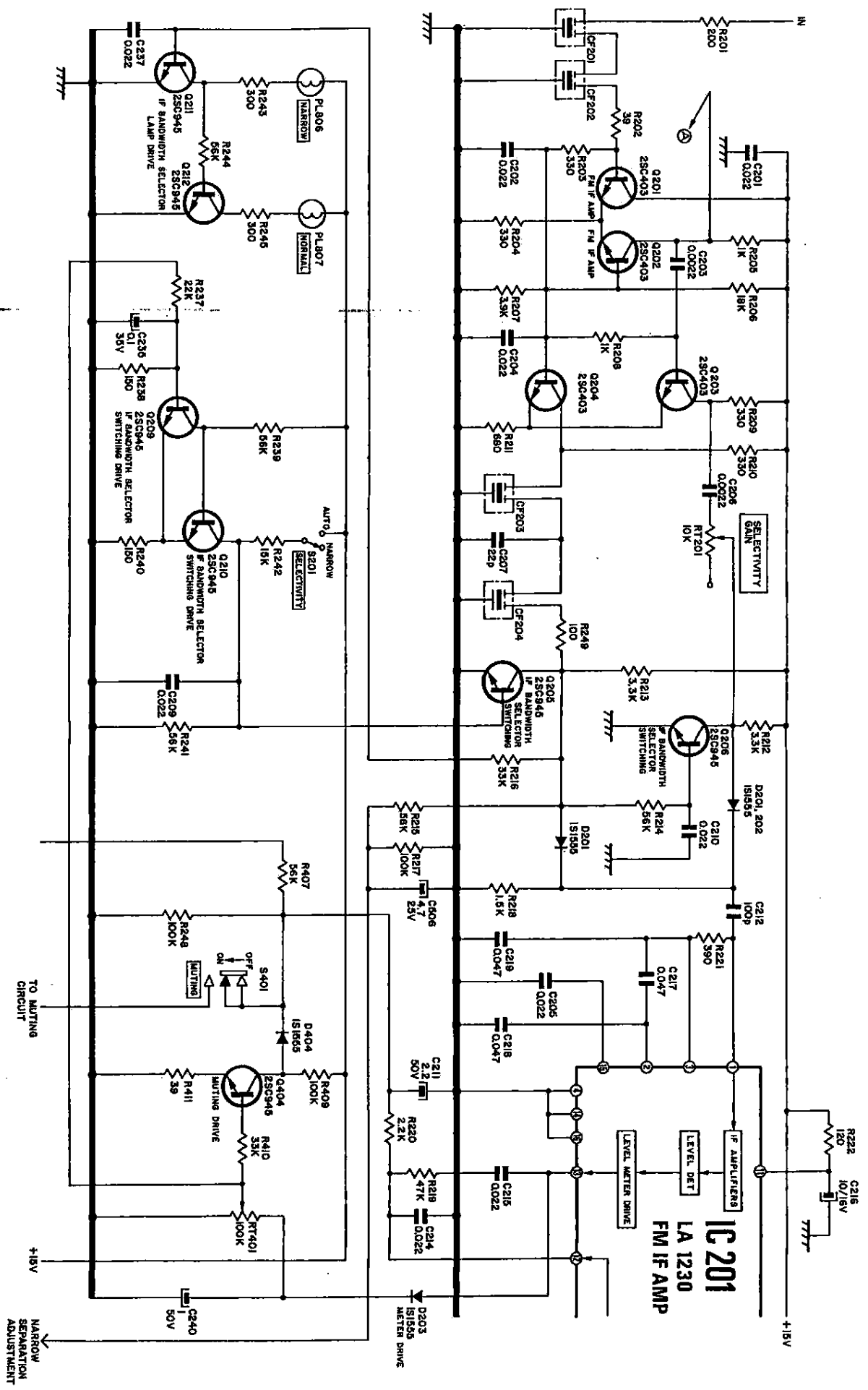

Fig. 1. ST-168 IF Bandwidth Control Circuitry

Muting

The DC output from pin 13 of IC201 is monitored by muting transistor Q404 (Fig. 1). With no or low input signal, the output of pin 13 is too low to turn on Q404, so its collector voltage goes high. This forward biases diode D404, connecting nearly +15V to resistor R412 (Fig. 2), providing the MUTING switch (S401) is set at ON.

Voltage applied to R412 turns transistor Q402 on and Q403 off. Transistors Q402 and Q403 are connected as a Schmitt trigger, so these transistors will switch states abruptly. The hysteresis of the Schmitt trigger circuit prevents the tuner from going in and out of muting due to noise and minor signal-level variations. Loss

of collector current in Q403 de-energizes relay RY401 and opens the signal path to the OUTPUT jacks. However, if the calibration tone is on (switch S701-5 closed), the voltage on the muting line is held to 0.7 volts by diode D401. This is insufficient to turn on Q402, so the signal path to the output jacks remains intact regardless of the signal level.

Transistor Q401 mutes the tuner when the POWER switch is turned on or off to prevent the power-supply transients that occur at those times from appearing at the OUTPUT jacks. Because Q401 supplies base current to relay transistor Q403, Q401 must be on for Q403 to energize the relay. When the ST-A6B is turned on,

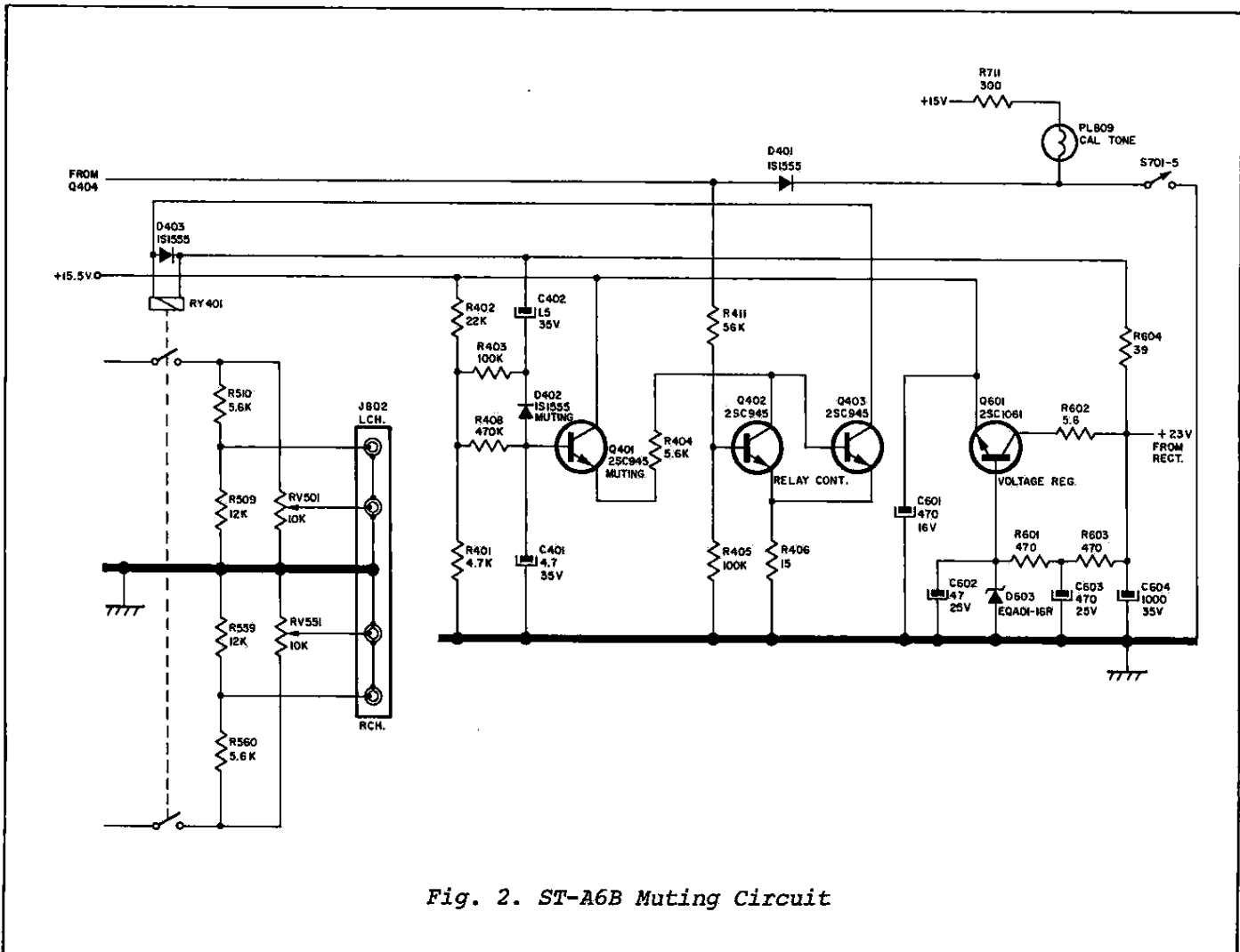

Fig. 2. ST-A6B Muting Circuit

the rising output voltage of the +15.5 volt regulator attempts to turn on Q401 via voltage divider R401/R402. However, this is delayed by capacitor C401 charging through resistor R408. The delay is long enough to permit the operating voltages throughout the ST-A6B to stabilize before the base voltage of Q401 rises high enough to turn on it and Q403.

When the ST-A6B is turned off, the voltage on the positive side of capacitor C402 will quickly drop towards ground. C402 will therefore forward bias diode D402, and lower the base voltage of Q401 enough to cut off this transistor and (thereby Q403) to effect muting.

Auxiliary Circuits

The ST-A6B contains an oscillator that provides a 400 Hz calibration tone for recording use, and an amplifier for the multipath signal. These circuits share transistor Q701 and a few resistors and capacitors; the setting of the SELECTOR switch (S701) determines in which of the two circuits the common parts are used. Fig. 3 shows the circuit diagram in each mode.

CAL-Tone Oscillator. Transistor Q701 is set up as a standard RC audio amplifier. However, three RC sections (R707/C705, R708/C706, and R702/C707) connected from output to input convert the amplifier into a phase-shift oscillator. The oscillator signal is coupled through capacitor C704 and resistors R305 and R308 to the tuner's buffer amplifiers.

Multipath Amplifier. Signal from the output to the first IF amplifier (where the level is very high but the signal has not undergone much limiting) is applied to a full-wave rectifier (germanium diodes D206 and D207). Changes in signal amplitude produced by the changing phase difference between the reflected (ghost) and incident (direct) signals appear as an AM signal. The detected amplitude changes (multipath) appearing across load resistor R250 are coupled through capacitor C246 to a two-stage RC-coupled amplifier (Q213 and Q701). The amplified multipath signal is rectified by diode D701 and applied to meter ME801. Capacitor C701 suitably shapes the meter response characteristics, while diode D702 conducts on very high multipath levels to keep the meter from pinning.

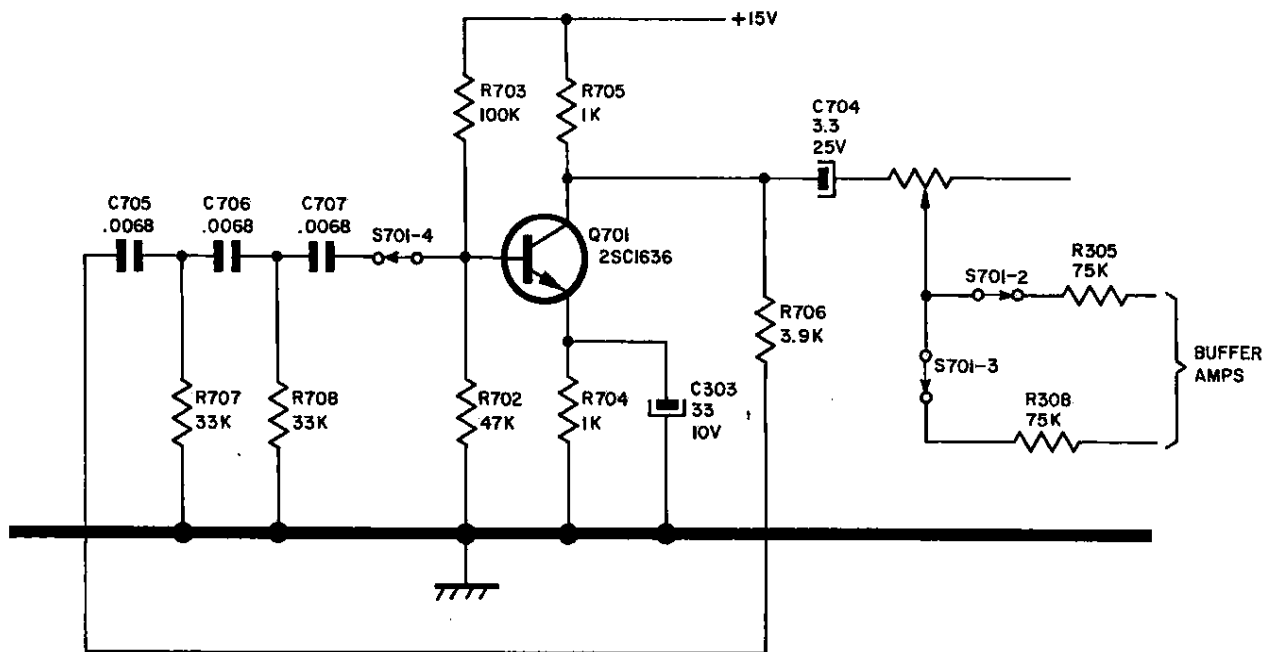

(a) CAL tone oscillator

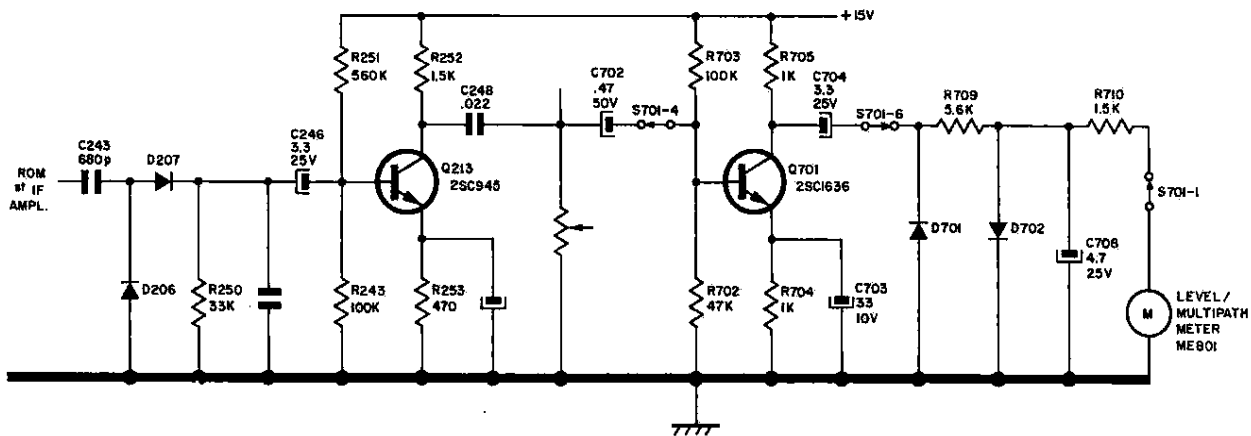

(b) Multipath amplification

Fig. 3. ST-A6B CAL-Tone Oscillator and Multipath Amplifier