

# ST-J75

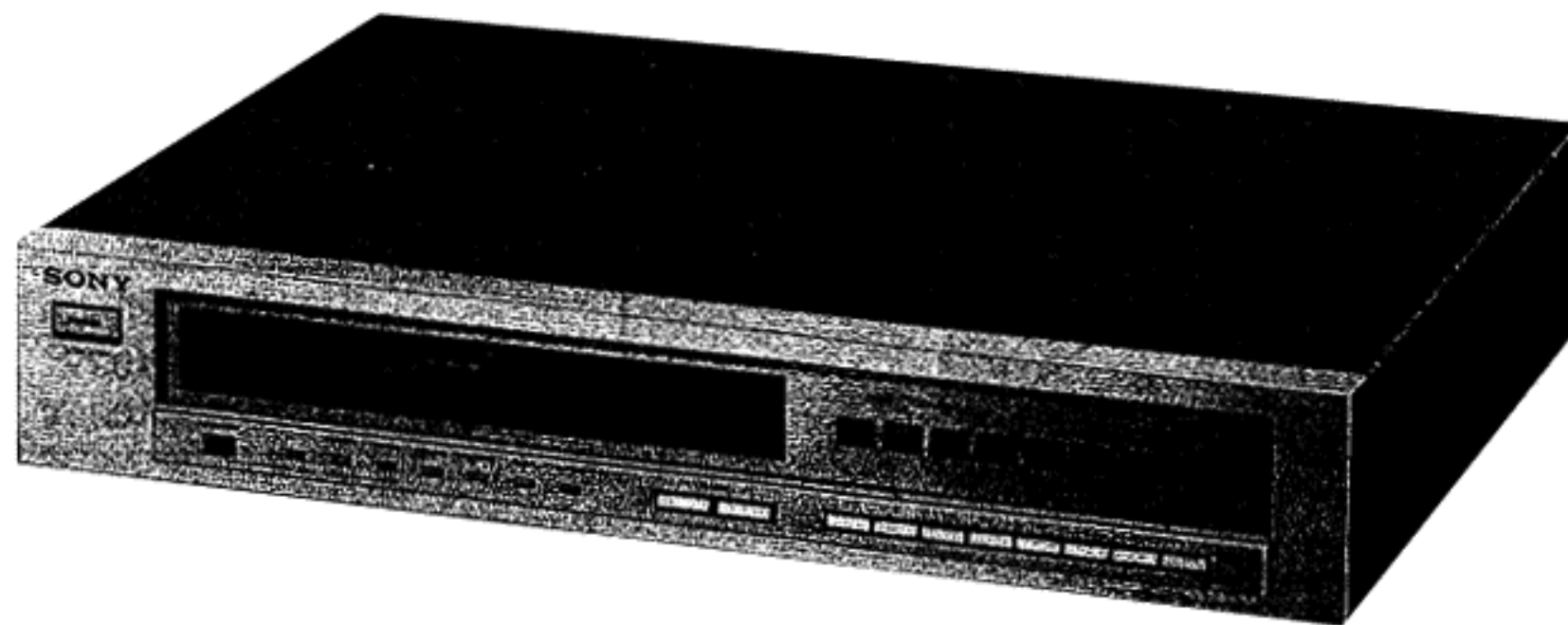

## FM STEREO TUNER

### SPECIFICATIONS

#### GENERAL

<b>System:</b>	PLL crystal-locked digital synthesizer system
<b>Power Requirements:</b>	US model 120 V ac, 60 Hz AEP, UK model 110, 120, 220 or 240 V ac adjustable, 50/60 Hz
<b>Power Consumption:</b>	US model: 20 W AEP, UK model: 18 W
<b>Dimensions:</b>	Approx. 430 (w) x 80 (h) x 315 (d) mm 17 (w) x 3 1/4 (h) x 12 1/2 (d) inches including projecting parts and controls
<b>Weight:</b>	US model Approx. 4.6 kg (10 lb 2 oz) net Approx. 5.4 kg (11 lb 15 oz) in shipping carton AEP, UK model Approx. 4.8 kg (10 lb 10 oz) net Approx. 5.6 kg (12 lb 6 oz) in shipping carton

#### TUNER SECTION

<b>Tuning Range:</b>	87.5 MHz – 108 MHz
<b>Antenna Terminals:</b>	300 $\Omega$ , balanced 75 $\Omega$ , unbalanced coaxial input
<b>Intermediate Frequency:</b>	10.7 MHz
<b>Sensitivity at 50dB Quieting:</b>	16.8 dBf, 3.8 $\mu$ V (mono) (US model) 37.3 dBf, 40 $\mu$ V (stereo)
<b>Sensitivity at 46dB Quieting:</b>	3.8 $\mu$ V (mono) (40kHz deviation) 40 $\mu$ V (stereo) (AEP, UK model)
<b>Usable Sensitivity:</b>	US model 10.8 dBf, 1.9 $\mu$ V AEP, UK model 1.4 $\mu$ V (S/N = 26 dB, 40 kHz deviation) 1.9 V, 10.8 dBf (IHF)
<b>Limiting Threshold:</b>	(AEP, UK model) 1.2 $\mu$ V

— Continued on page 2 —

#### SAFETY-RELATED COMPONENT WARNING!!

COMPONENTS IDENTIFIED BY SHADING AND MARK  ON THE SCHEMATIC DIAGRAMS, EXPLODED VIEWS AND IN THE PARTS LIST ARE CRITICAL TO SAFE OPERATION. REPLACE THESE COMPONENTS WITH SONY PARTS WHOSE PART NUMBERS APPEAR AS SHOWN IN THIS MANUAL OR IN SUPPLEMENTS PUBLISHED BY SONY.

# SONY<sup>®</sup>

---

# SERVICE MANUAL

**S/N Ratio:**

	US model	AEP, UK model	
		40kHz deviation	75kHz deviation
mono	92dB	92dB	87dB
stereo	86dB	86dB	81dB

**Harmonic Distortion:**

	mono	stereo
at 100Hz	0.05%	0.08%
at 1kHz	0.05%	0.07%
at 10kHz	0.05%	0.2%

**IM distortion:** 0.05 % (mono),  
(40kHz deviation) 0.07 % (stereo)

**Separation:**

	US model	AEP, UK model
at 100Hz	55dB	50dB
at 1kHz	60dB	55dB
at 10kHz	45dB	40dB

**Frequency Response:** US model  
30 Hz – 15 kHz +0.2 dB  
-0.5 dB

AEP, UK model  
40 Hz – 12.5 kHz ± 0.2 dB  
30 Hz – 15 kHz +0.2 dB  
-0.5 dB

**Selectivity:** 30 dB at 200 kHz, 80 dB at 300 kHz**Capture Ratio:** 1.5 dB**AM Suppression Ratio:** 65 dB**Image Response Ratio:** 95 dB**IF Response Ratio:** 100 dB**Spurious Response Ratio:** 100 dB**RF Intermodulation:** 78 dB (IHF), 100 dB (2.4 MHz)**Sub-carrier Product Ratio:**  
US model: 75 dB  
AEP, UK model: 66 dB**Muting and Auto-tuning Threshold:**

	US model	AEP, UK model
LOW	25dBf, 10μV	10μV
HIGH	45dBf, 100μV	100μV

**Output Level/ Impedance:**

(75kHz deviation) 750 mV, 600 Ω

**Calibrating Tone:** US model  
50 % modulation (37.5 kHz deviation),  
400 Hz  
AEP, UK model  
375 mV (37.5 kHz deviation),  
400 Hz**MODEL IDENTIFICATION**

— Specification Label —

**US model**

<b>SONY</b>	<b>FM STEREO TUNER</b>	
	MODEL NO. <b>ST-J75</b>	
	FREQ. RANGE	: FM87.5–108MHz
	IF	: FM 10.7MHz
	AC	120V 60Hz 20W
SERIAL NO.		MADE IN JAPAN
CERTIFICATION : DESIGN CERTIFIED AS COMPLYING WITH F. C. C. RULES PART 15, IN EFFECT AS OF DATE OF MANUFACTURE.		

**AEP model**

<b>SONY</b>	<b>FM STEREO TUNER</b>	
	MODEL NO. <b>ST-J75</b>	
	FREQ. RANGE	: FM87.5–108MHz
	IF	: FM 10.7MHz
	AC	110, 120, 220, 240V ~ 50/60Hz 18W
SERIAL NO.		MADE IN JAPAN
FTZ-PRÜFNUMMER U185		

**UK model**

<b>SONY</b>	<b>FM STEREO TUNER</b>	
	MODEL NO. <b>ST-J75</b>	
	FREQ. RANGE	: FM87.5–108MHz
	IF	: FM 10.7MHz
	AC	110, 120, 220, 240V ~ 50/60Hz 18W
SERIAL NO.		MADE IN JAPAN

## Handling Precautions for MOS ICs

Generally, the insulation resistance of the oxide layer in MOS IC structures is very high, and the oxide layer is very thin. Because of this, it is possible that the static voltages usually present on clothes and the human body will be enough to generate a potential difference across the insulator, high enough to cause a breakdown of the insulating layer.

The following precautions should be taken while handling these ICs.

(Particular care should be taken under conditions of low humidity.)

### Precautions in Replacing MOS ICs

1. Store new ICs by inserting them into a urethane-polyester cushion (which is somewhat conductive), or wrapping it in aluminum foil, so that all the pins are at the same potential. (The ICs should be stored in that manner until mounted on the circuit board.)

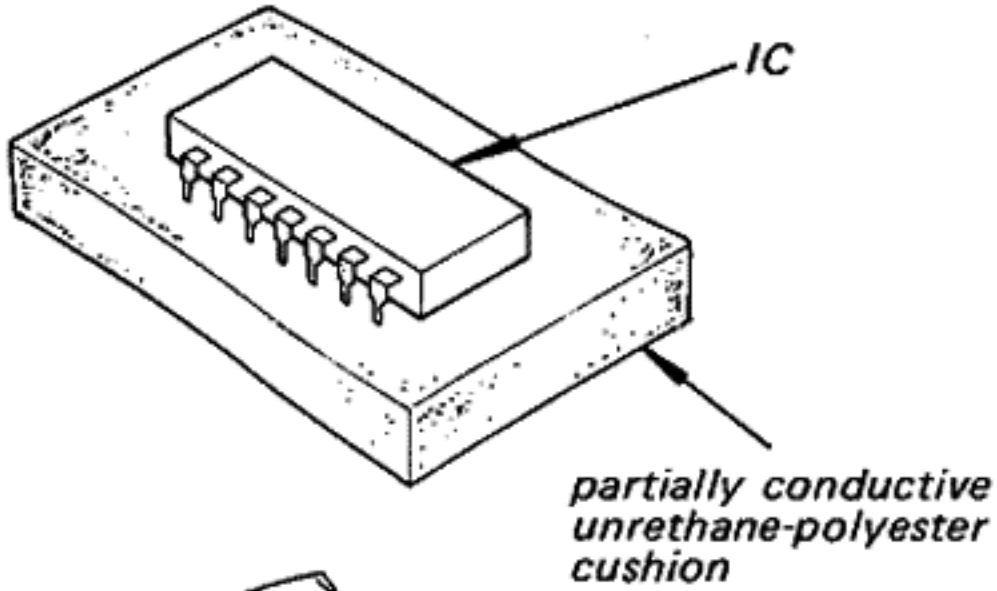

Fig. A

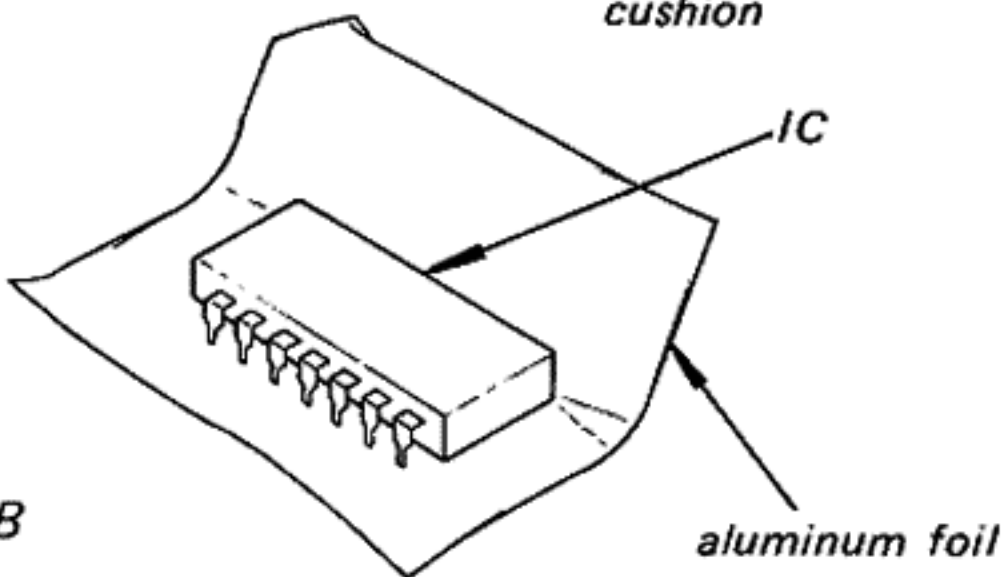

Fig. B

2. Check the soldering iron for possible power-line leakage current. Make sure that there is no leakage path by connecting an ohmmeter to the tip of the soldering iron and the plug as shown in Fig. C. If there is a leakage path, use some other soldering iron.

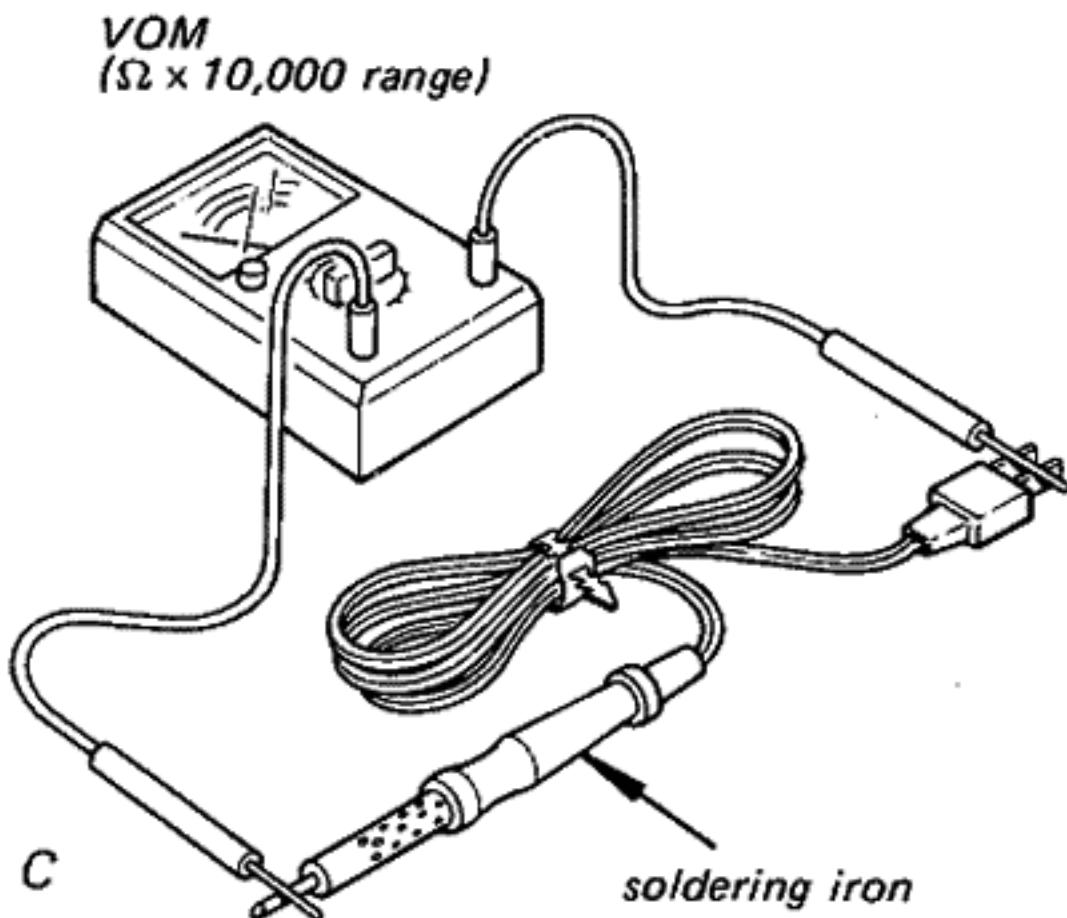

Fig. C

3. Equalize any potential difference between the clothes, the tools in use, the work bench, the set being worked on, and the packaged IC by touching them all in succession with the hands or a conductive wire or tool.
4. The following are effective methods for handling ICs that remove the potential difference across the oxide layer.
  - Use a paper clip modified by soldering in a wire braid insert.

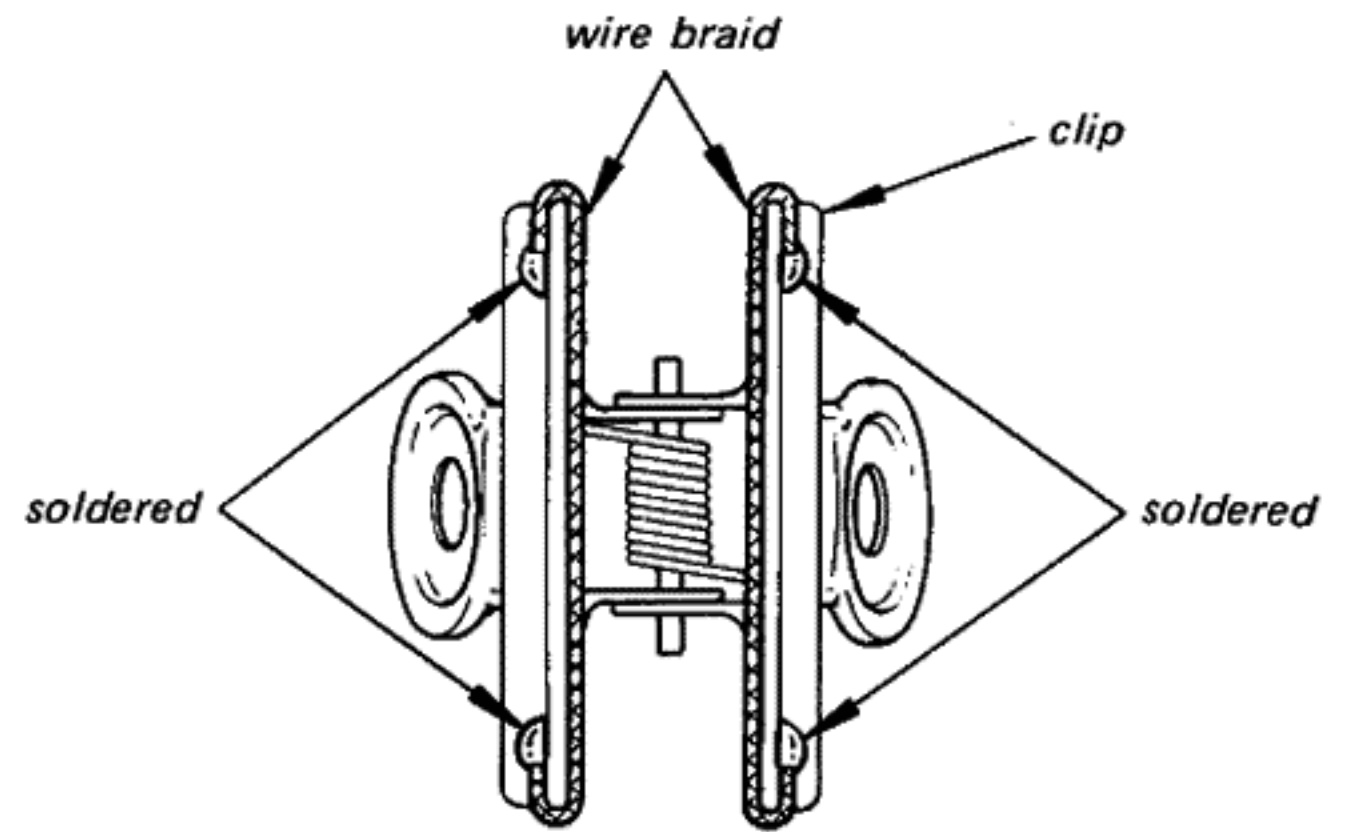

Fig. D

Make sure that there is no solder on the inside.

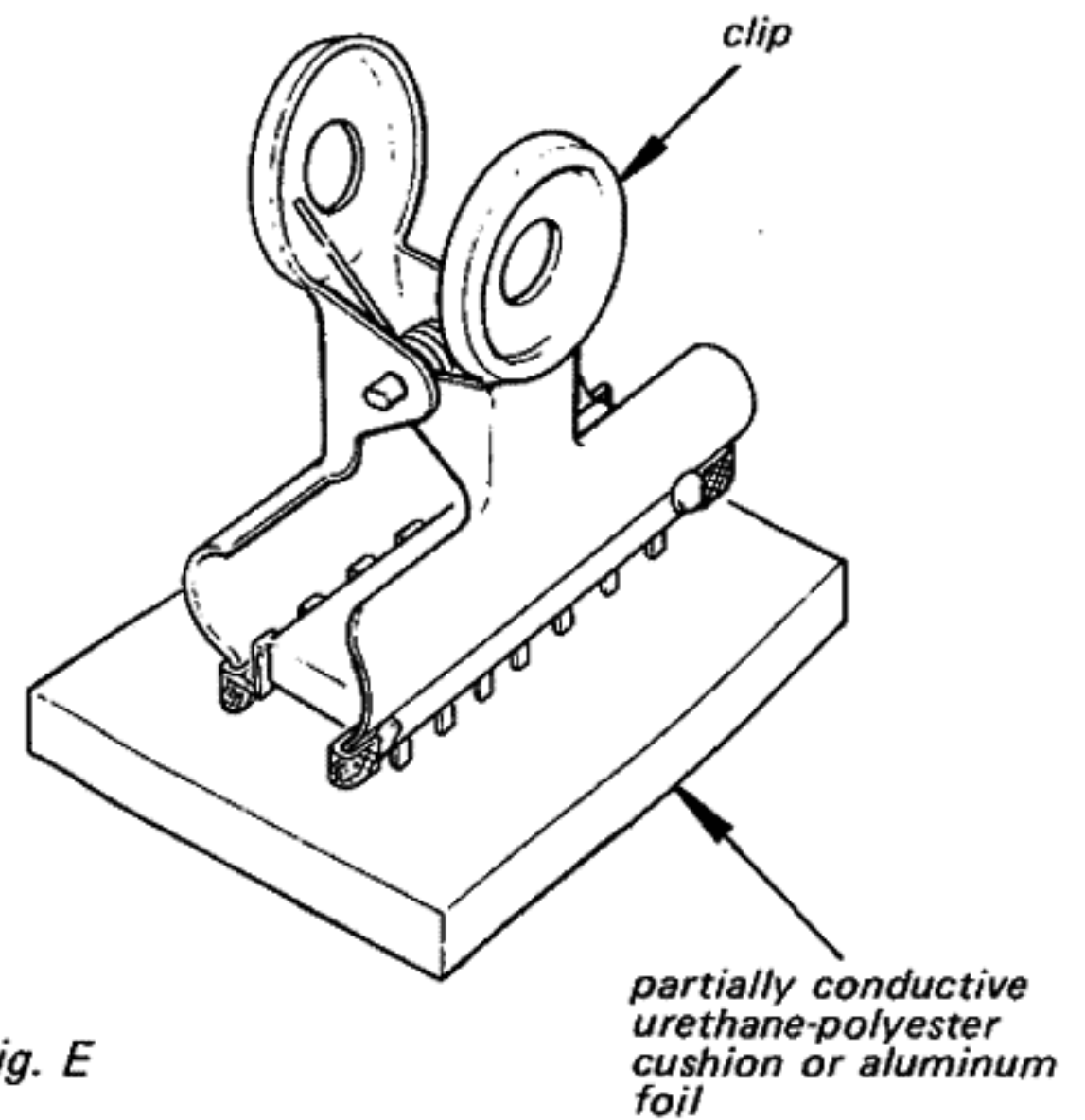

Fig. E

partially conductive urethane-polyester cushion or aluminum foil

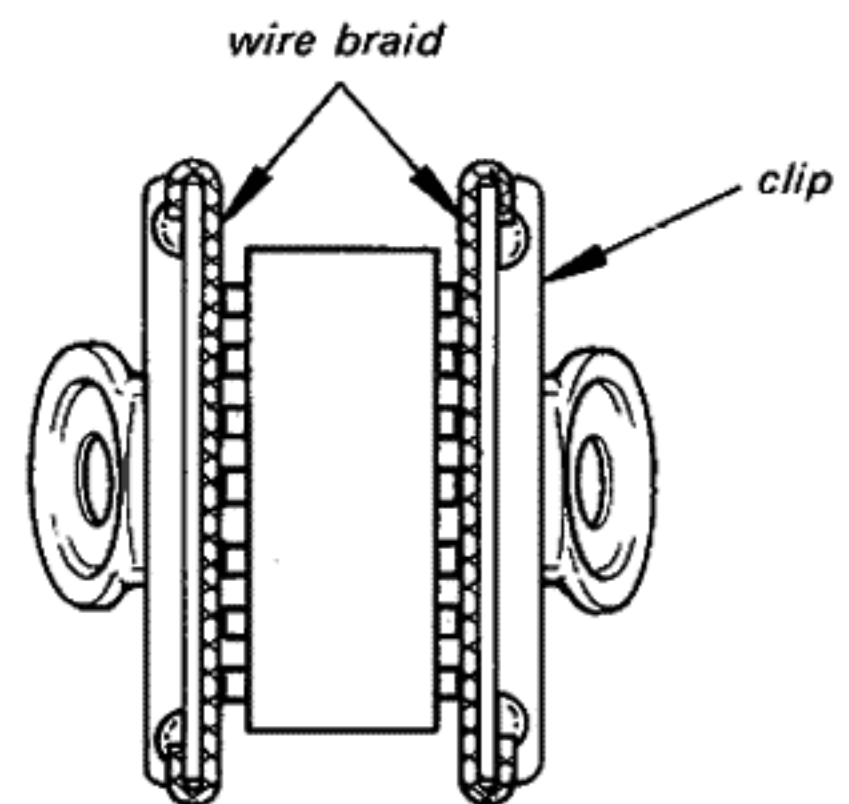

Fig. F

Make sure that all the pins are in contact with the wire braid (all the pins will then be at the same potential.).

- Take a short length of fine bare wire and wind it around the IC so that it shorts all the pins of the IC, while it is still in the urethane-polyester cushion or aluminum foil. This ensures that all the pins are at the same potential.

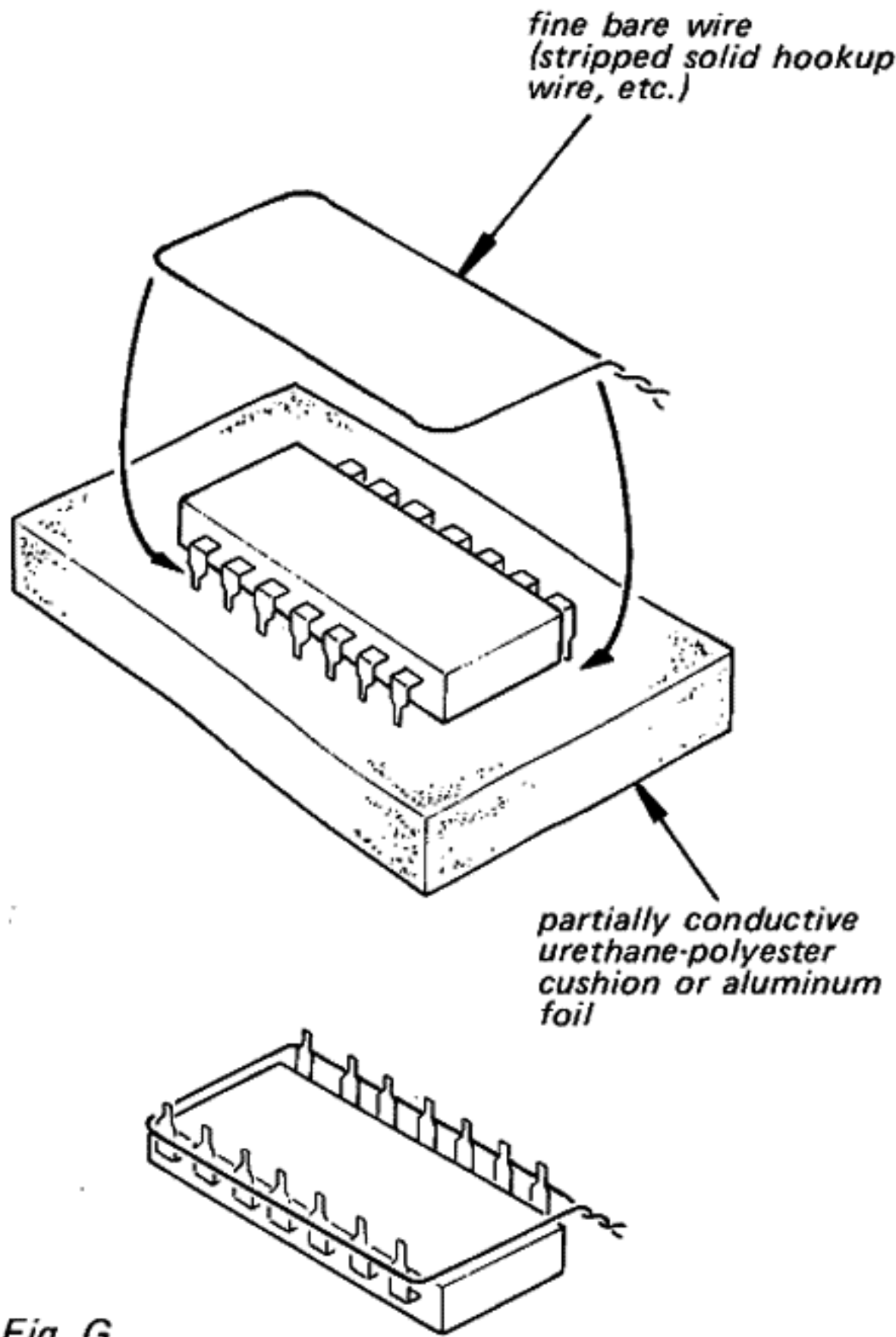

Fig. G

- When it is necessary to handle the IC with the fingers, do not touch any pin, and hold the IC at the ends of its plastic-package case as shown in Fig. H.

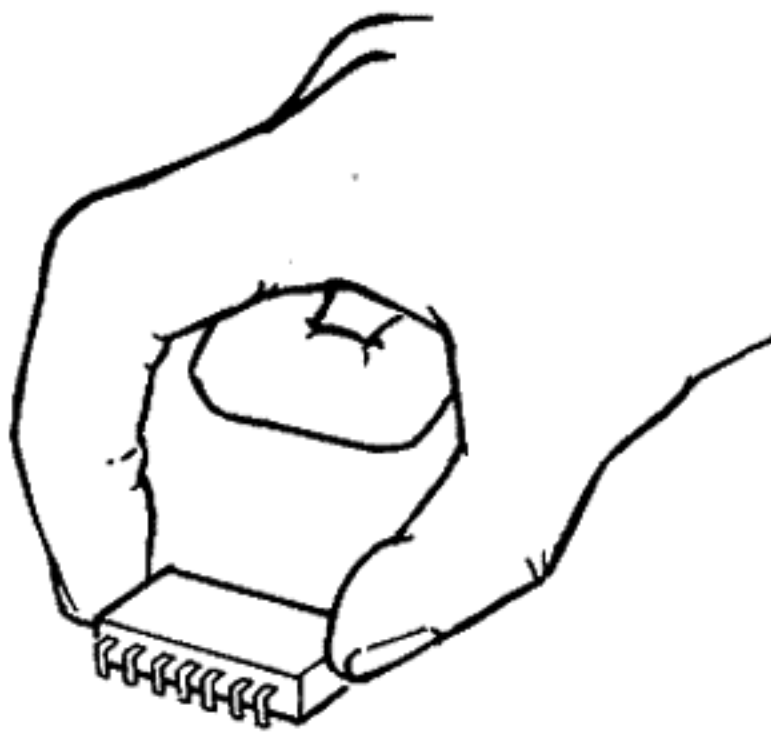

Fig. H

#### 5. Method of Mounting

Insert the IC while holding it with the modified clip, and solder all the pins with the clip still shorting the pins. (Similarly, solder all the pins while the bare shorting wire is still wound around them.) Remove the clip or the bare shorting wire only after all the pins have been soldered.

#### Precaution while Checking C-MOS ICs

The C-MOS ICs (Complementary MOS) are MOS ICs that have their output sections made up of N-channel and P-channel push-pull stages to increase their speed of operation. If the output terminal of these ICs comes into contact with B+ or B- voltage, then the FET which is ON at that time will either become shorted or open.

This is valid for all the output sections that are connected together by the interconnections. Even the circuits that are physically separated (and not on the same board) can be destroyed simultaneously.

#### Example:

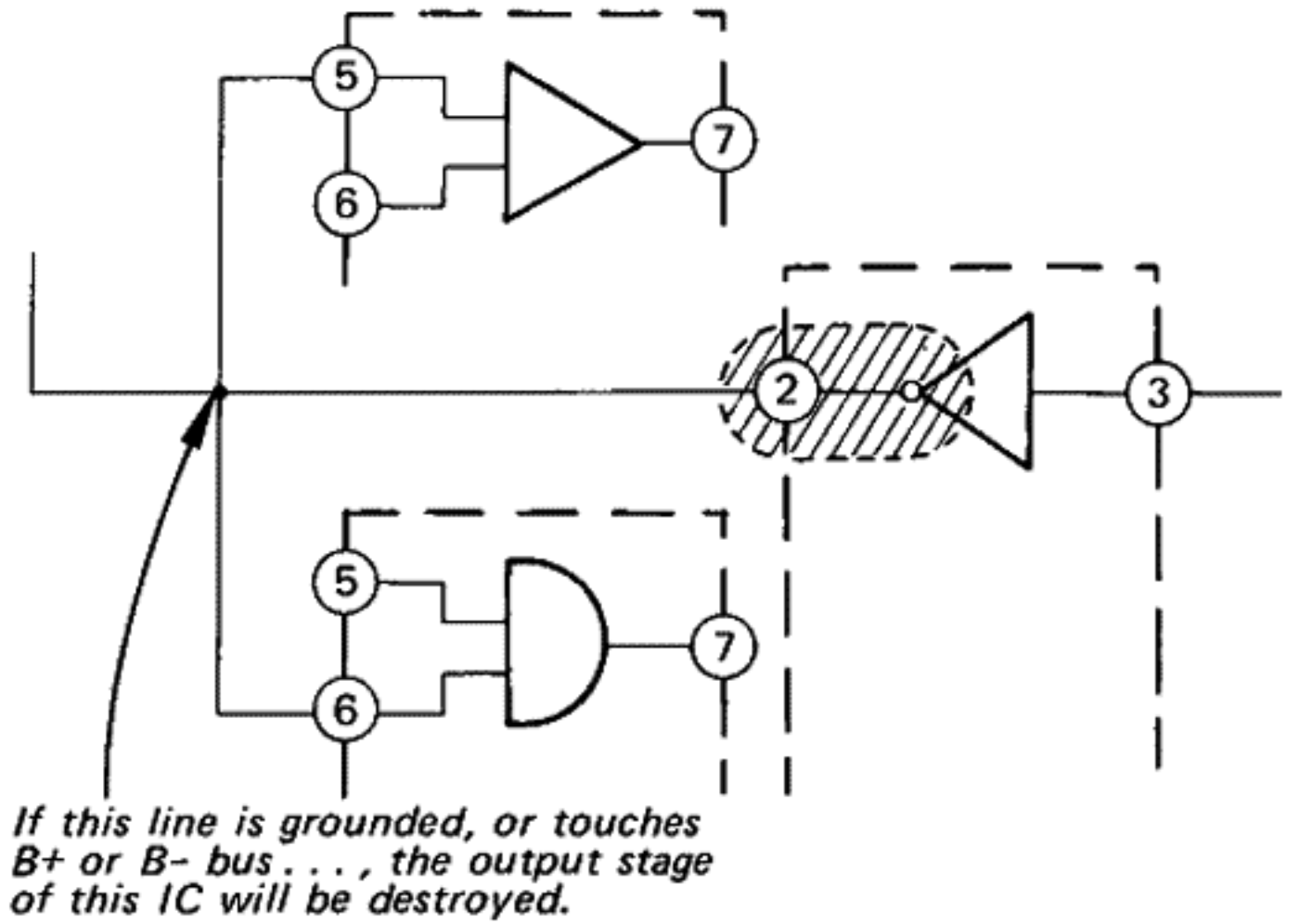
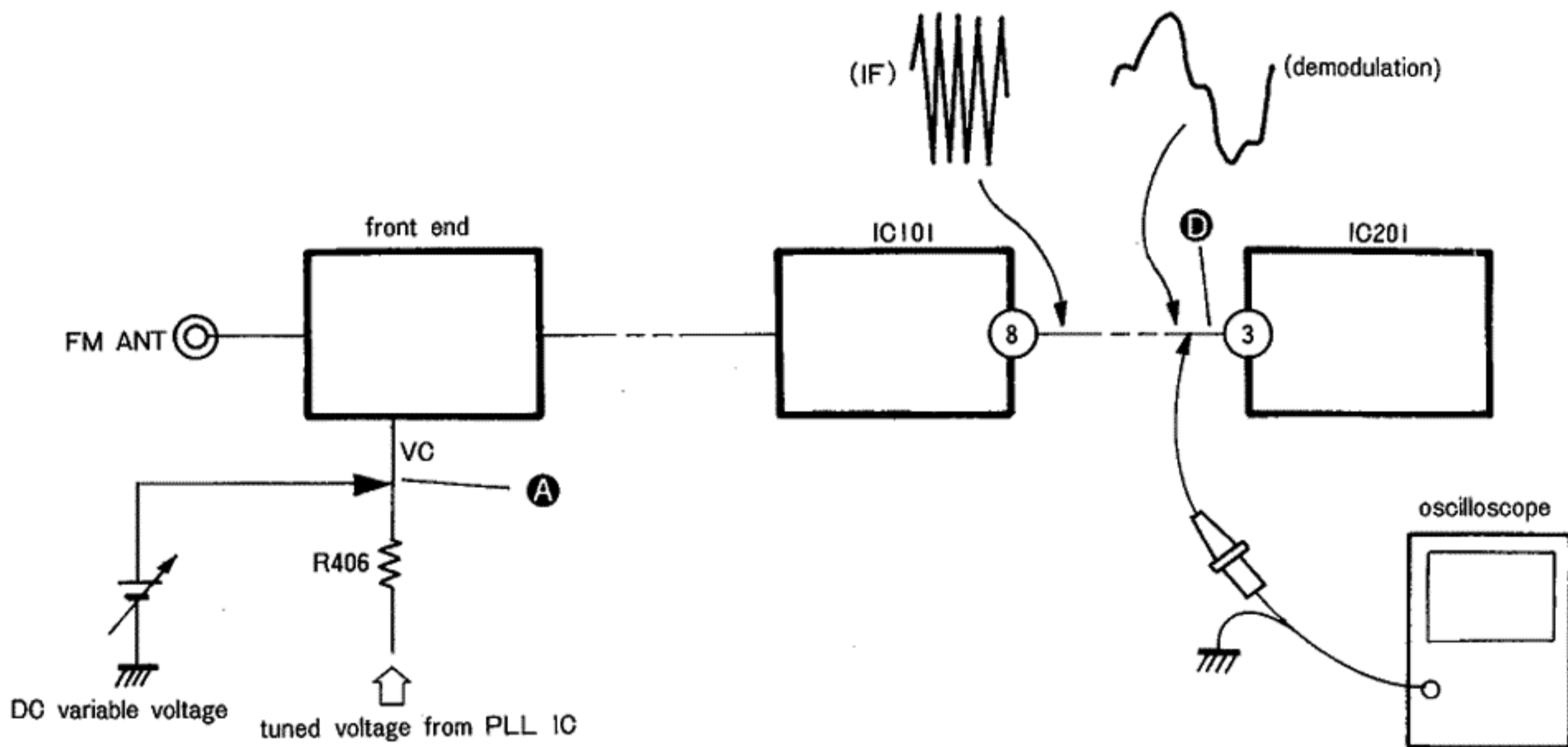

Fig. I

# SECTION 1 OUTLINE

## 1-1. CIRCUIT DESCRIPTION



### TROUBLE CHECKS FOR FM RECEPTION

When FM signal can not be received, make above connection. Regardless of the computer or the PLL synthesizer, trouble checks for FM reception can be made.

### How to Check

1. Connect an oscilloscope or an earphone with point **D**.
2. Check whether there is noise or broadcast on an oscilloscope or through an earphone.
3. Make sure that stations can be received one after another when changing DC variable voltage from approximately 0V to 20V.

### $\mu$ PD533C-073 (IC501)

IC501 ( $\mu$ PD533C-073) is a one-chip microcomputer. Configuration of the computer system is shown below.

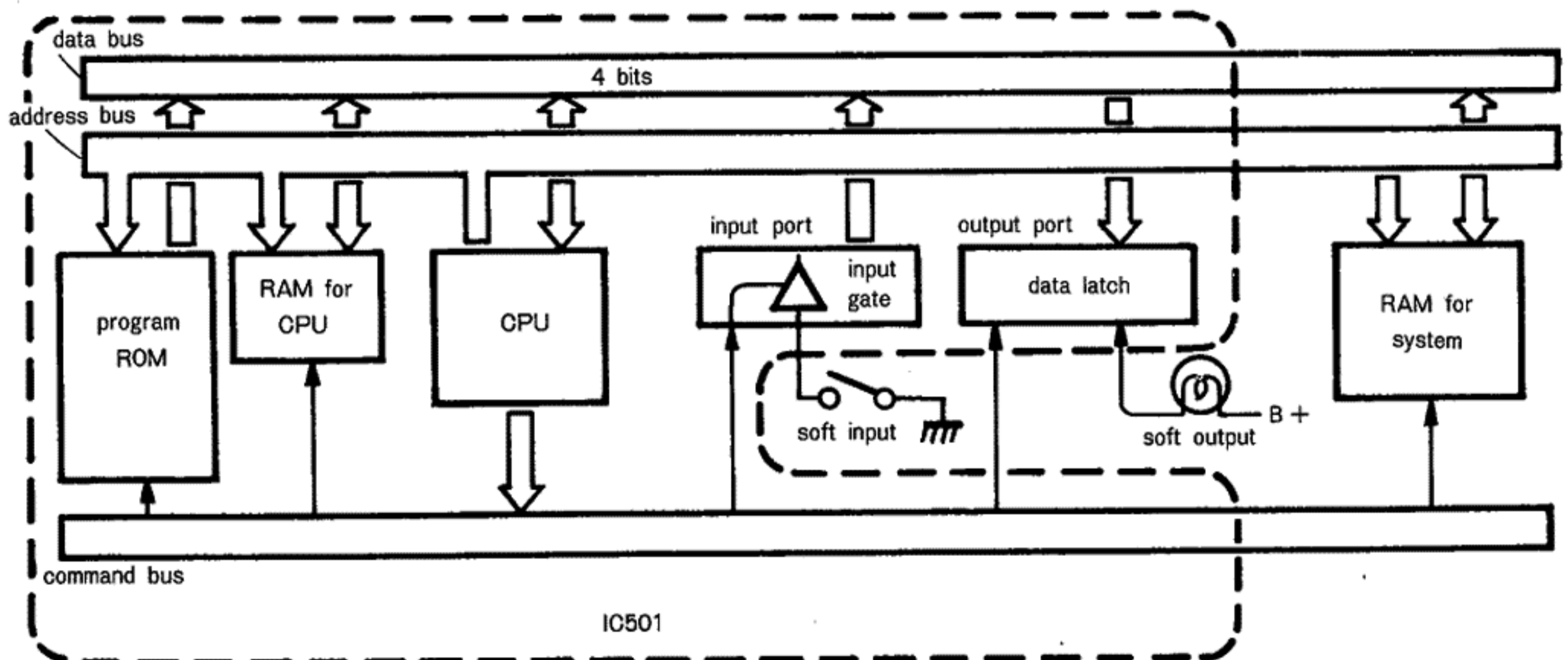

Above figure is an example of the computer system composed by six individual ICs.  $\mu$ PD533C has functions of ICs surrounded by the broken line. In the above figure there is only one pair of I/O ports and I/O can be made in four-bit parallel manner. This set has nine pairs of the ports each of which is four bits except one port which is three.

RAM on the far right is the memory capable of presetting up to 8 stations and maintains the memorized information for a long time without a battery back-up after the power switch is turned off. Suffix of IC501, that is 073, shows that the program for ST-J75 has already been written in IC501.

## CX778 (IC401)

IC401 is the PLL synthesizer to control local oscillator frequency by comparing it with reference frequency. As the local oscillator output is directly (without any additional prescaler) supplied to the programmable counter section, reference frequency is as high as the channel spacing frequency. The benefits owing to this are the stable and almost ripple-less local oscillation and reduced spurious radiation.

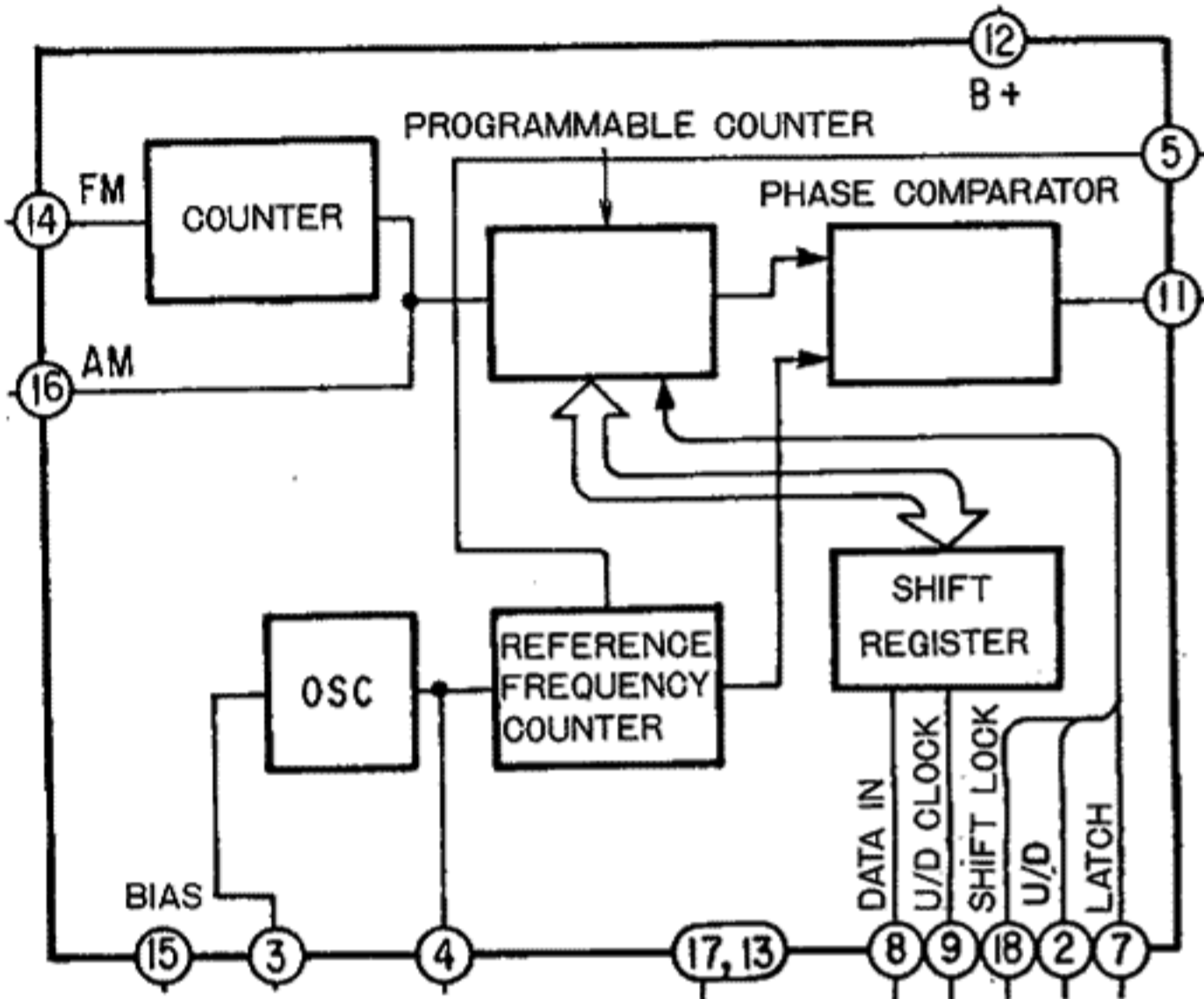

## Function of Terminals

Pin No.	Mark	Function
1	Data Check	not used in this set
2	U/D	input terminal for selecting mode of built-in UP/DOWN counter HIGH level: UP mode LOW level: DOWN mode
3, 4	X <sub>1</sub> , X <sub>0</sub>	terminal for connecting crystal oscillator (7.2MHz)
5	Sys CLK	output terminal for system clock in phase comparator 360kHz
6	Fref	output terminal for reference frequency
7	Latch	input terminal for signal to let the shift register latch the data Data is latched at HIGH level
8	Data IN	input terminal for data
9	Shift CLK	input terminal for clock to let data input in 16-bit parallel manner
11	PD	output terminal for phase comparator (tristate)
12	V <sub>DD</sub>	power supply (+5V)
13	Fout	output terminal for divided signal from the programmable counter
14	FM IN	input terminal for signal from FM local oscillator
15	Sub	substrate
17	GND	ground
18	U/D CLK	input terminal for UP/DOWN clock of UP/DOWN counter

As shown above, the programmable counter for changing frequency gets the data through the shift register.

### Data Input Procedure from Microcomputer:

#### ● Setting of division ratio

Data for setting division ratio of the programmable counter, comparison frequency and the pin for input are input by 16-bit serial manner by using terminals DATA IN, SHIFT CLOCK and LATCH. The first 12 bits (D<sub>0</sub> – D<sub>11</sub>) of this 16-bit data works for

setting division ratio of the programmable counter and the last 4 bits (C<sub>0</sub> – C<sub>3</sub>) works for controlling comparison frequency. Timing chart when data are input is as follows.

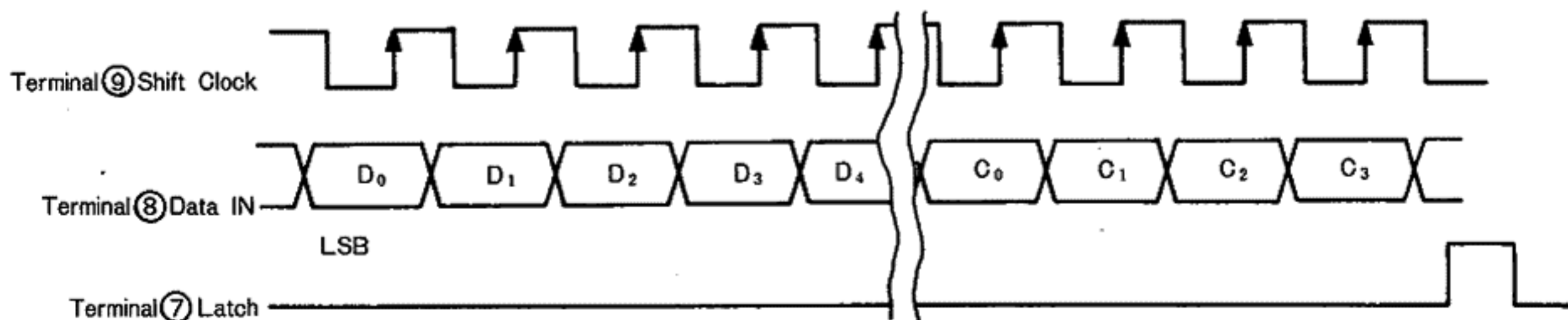

- Input waveform of UP/DOWN pin is as follows.

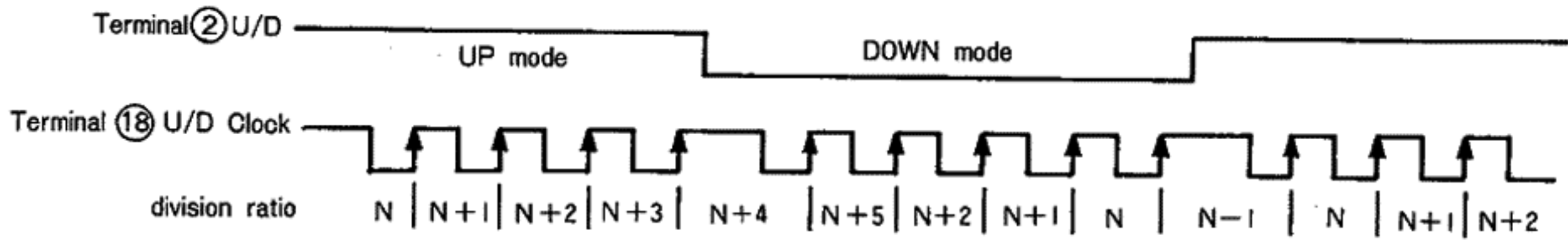

Each terminal receives instructions from the CPU which are expressed with the combination of "0" and "1". There is no meaning in measuring waveform at each terminal with an oscilloscope, because combination of "0" and "1" changes every moment without any rule. Few examples are shown below.

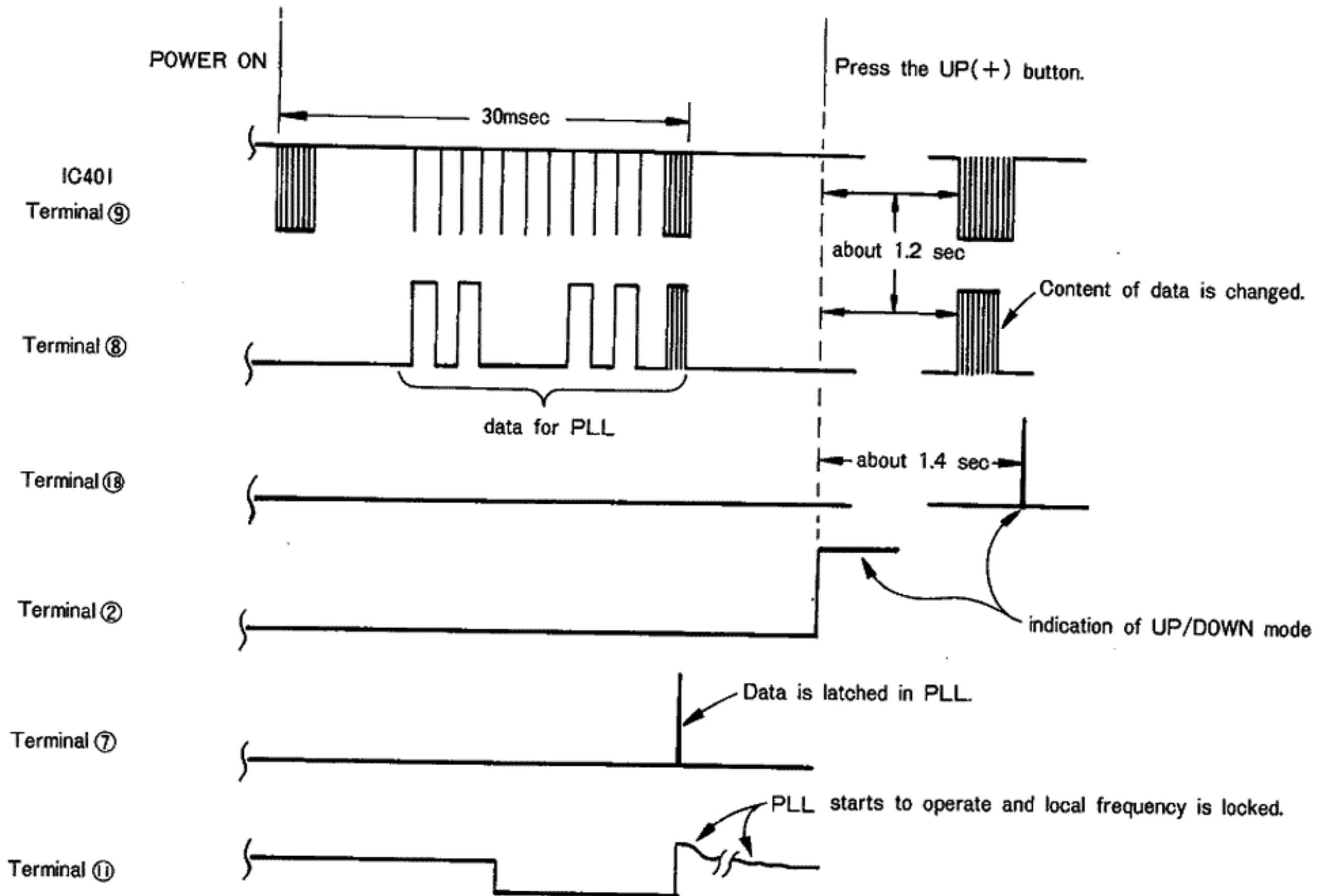

## MEMORY IC CX761 (IC502)

### Outline of CX761:

- This is a non-volatile memory IC. Has 260 (16 words x 16 bits + 4 bits) non-volatile memory transistors built in, and works for reading, erasure and writing the data word.
- Because of being a non-volatile type memory, this IC maintains the memorized informations for a long time without a battery back-up after the power switch is turned off.
- Word address is done by the BCD inputs.
- Silicon-type P-channel enhancement NMOS IC construction.
- 14-pin molded DIP casing.

### Function of Terminals:

Terminal	IN or OUT	Function
1	IN	Word address D
2	IN	Word address C
3	IN	Word address B
4	IN	Word address A
5	IN	Power supply input
6	IN/OUT	Writing and erasure control inputs/memory-BUSY output
7	IN	Power supply input
8	IN/OUT	Inputs and outputs for test checkout
9	IN	Test signal
10	IN/OUT	Combined data inputs and data outputs
11	IN	Input for synchronous clock
12	IN	Input for mode control C3
13	IN	Input for mode control C2
14	IN	Input for mode control C1

### Mode Control Signals

MODE INPUT	SB	RTNS	WTNS	WRT	MSTNS	ERS	READ	MCTNS
C1	0	1	0	1	0	1	0	1
C2	0	0	1	1	0	0	1	1
C3	0	0	0	0	1	1	1	1

#### Note:

- SB: Standby
- RTNS: Informations of the data register (relayed by the READ operation) are put out from the D I/O terminal
- WTNS: Informations to be memorized are relayed to the data register from the D I/O terminal
- WRT: Memorize the informations relayed by the WTNS operation in the designated address
- ERS: Clears the informations memorized in the designated address
- READ: Relay the memorized informations in the designated address to the data register
- MSTNS: The control signals which follow the MSTNS operation are processed in accordance with the station memory
- MCTNS: The control signals which follow the MCTNS operation are processed in accordance with the last channel memory.

## IC504 (4 bits x 4 latch)

There are 4 ports for latching each of which can receive command from the CPU. The port selector signal from the CPU selects which port receives the command.

### Display Function of Microcomputer

The display of this set is the dynamic light-up system which is made by the digit and the data for a segment from the CPU.

### How to Check the Microcomputer with an Oscilloscope

When a microcomputer is in normal condition, programs in the CPU are executed in a certain sequence when the power switch turns on. This is owing that the ROM program is written in. Following check can be made according to the above mentioned logic.

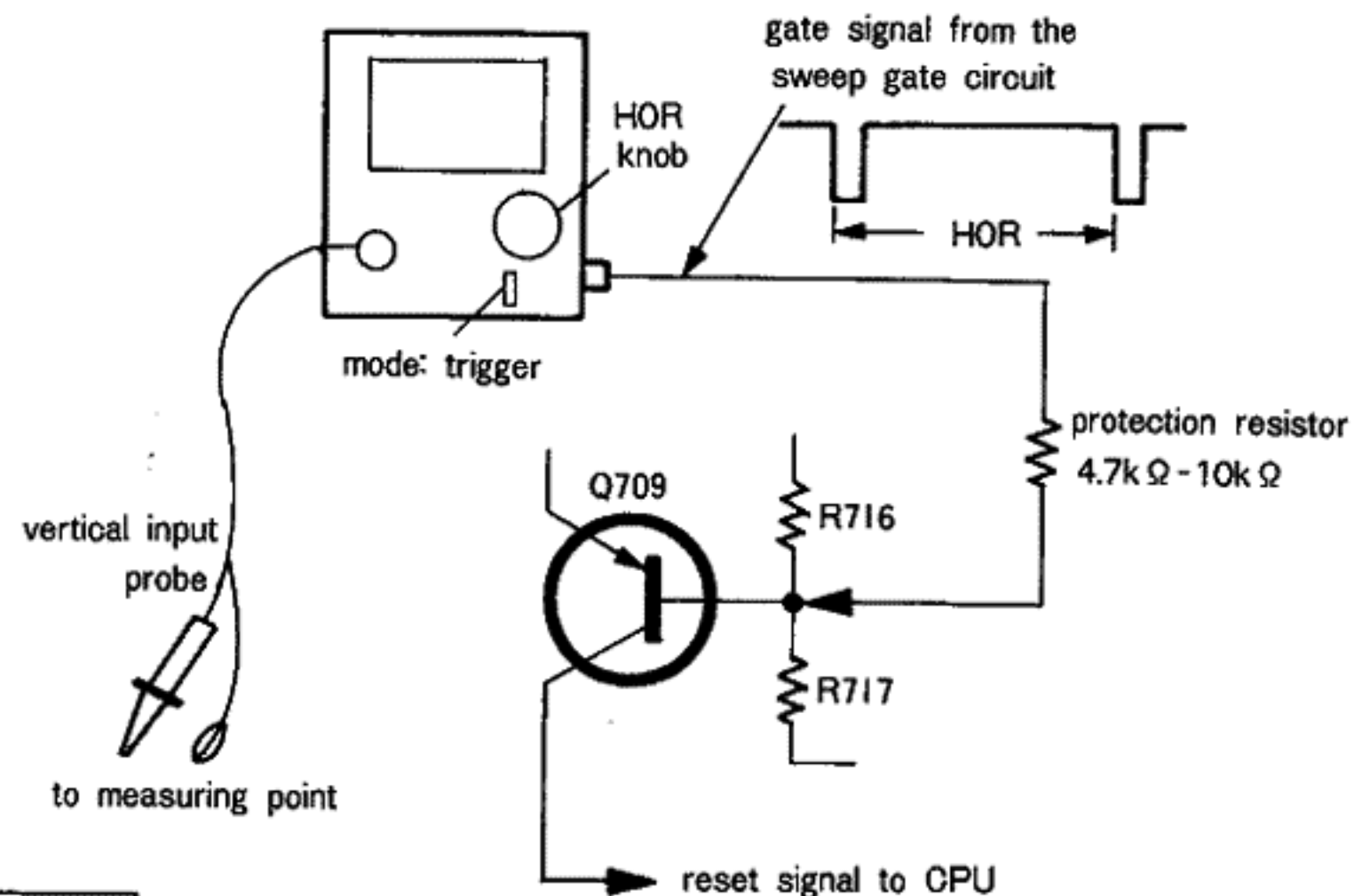



### How to Check

- Connect the gate output of an oscilloscope with Q709 via a protection resistor. When the oscilloscope is turned on, the CPU starts.
- oscilloscope: free running (that is, trigger mode: AUTO)
- HOR of oscilloscope: 5msec DIV

If necessary, measure each section with a probe. (The fact that the frequency is displayed on the frequency counter means that a microcomputer is in normal condition, because frequency display is made after finishing every preparation.)

### Input and Output of TMS 1024 (IC504)

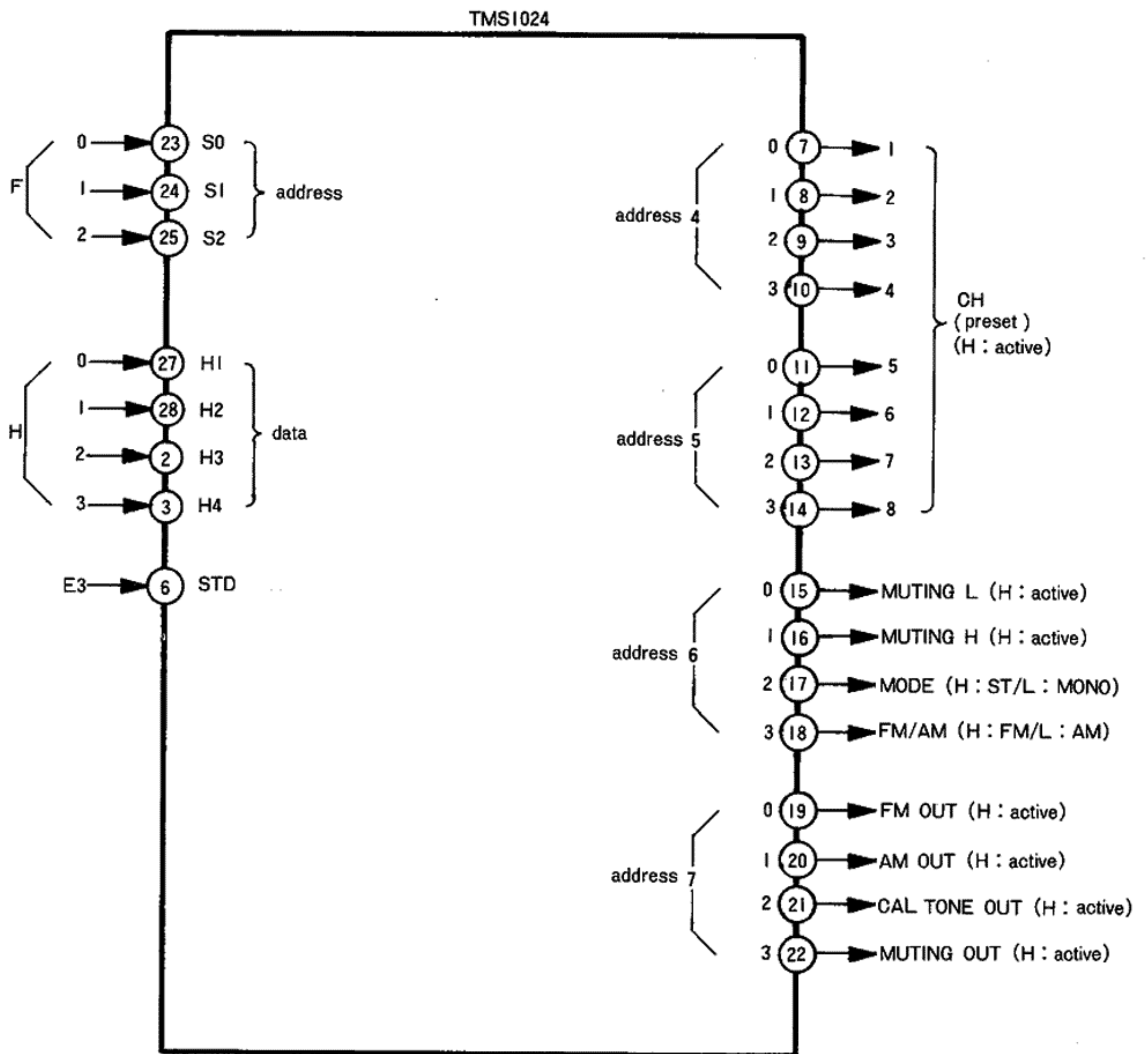

### Input and output of $\mu$ PD553C-073

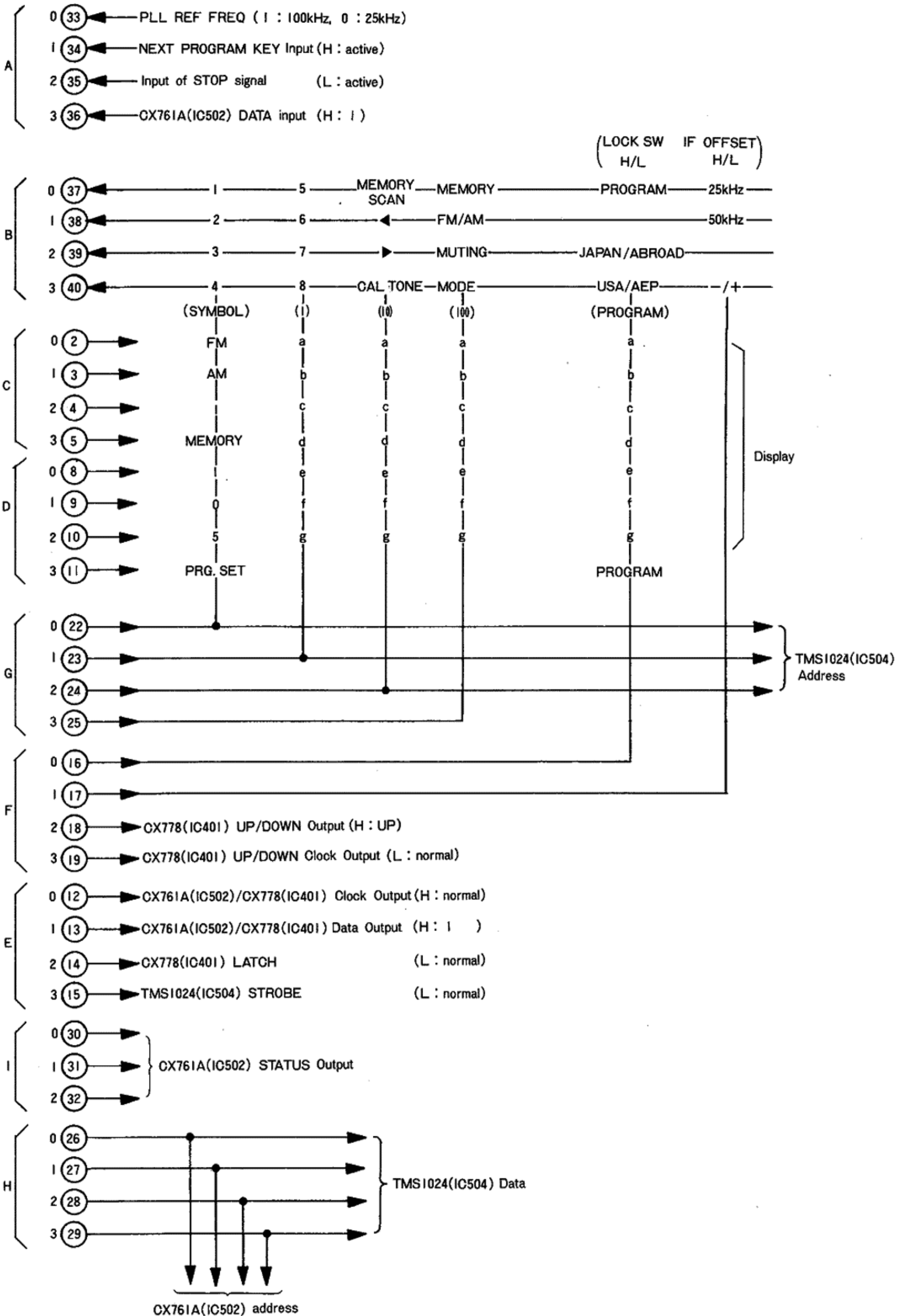

# SECTION 3 ADJUSTMENTS

## 3-1. ELECTRICAL ADJUSTMENT

### • Before Adjustments

PROGRAM switch: OFF

POWER switch: ON

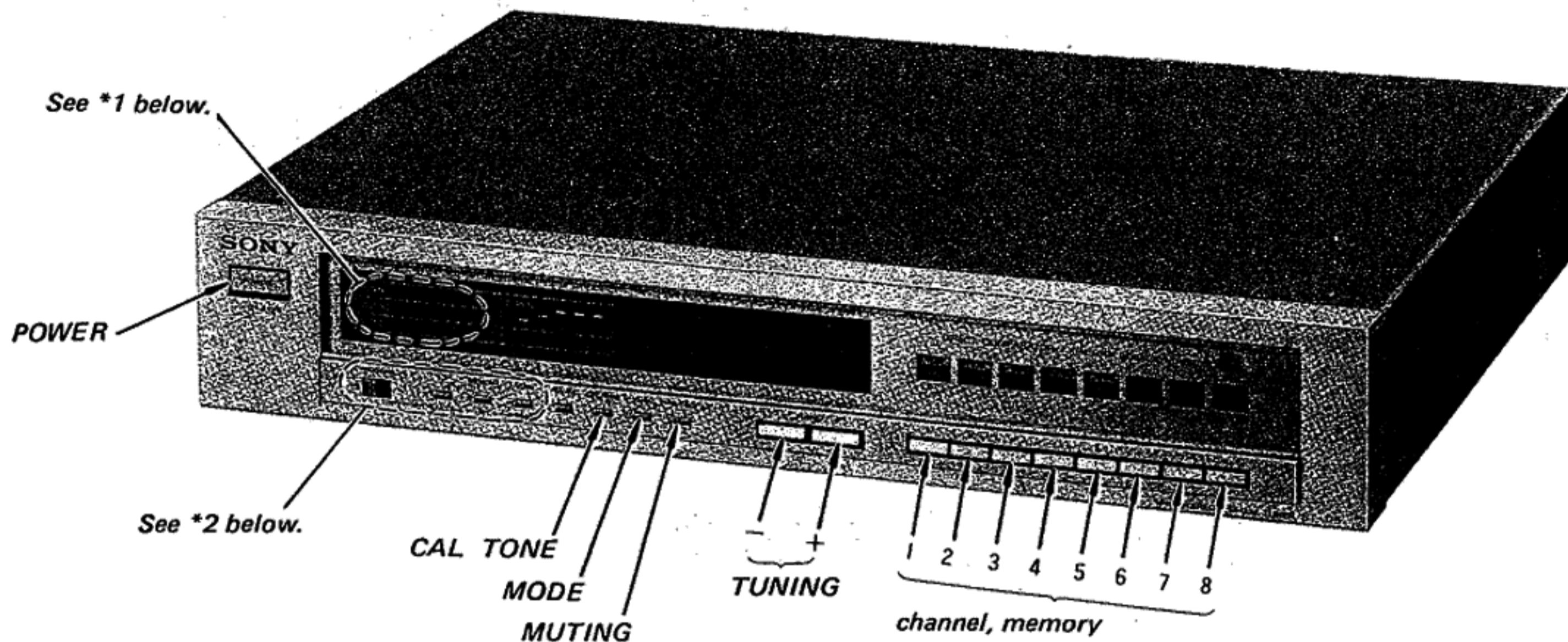

\* 1

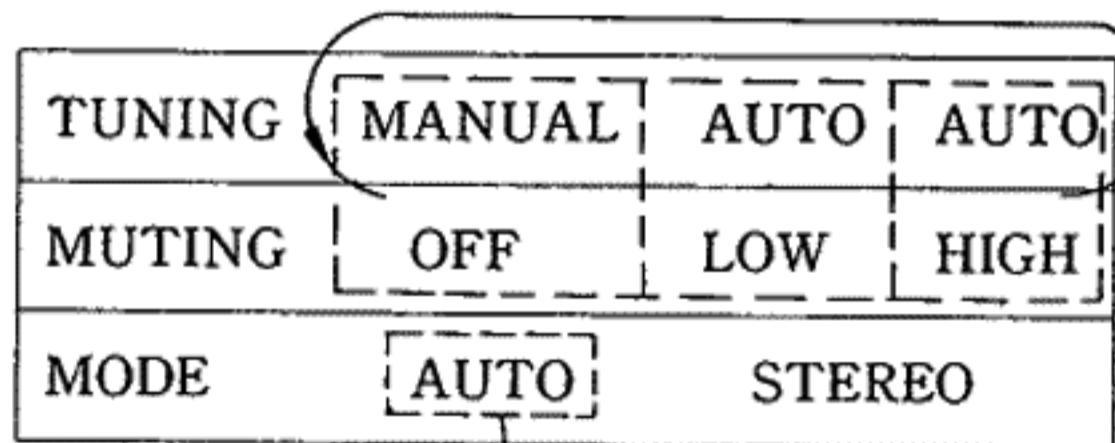

Each time MUTING switch is pressed, indication changes in sequence.

Each time MODE switch is pressed, indication "AUTO" lights up or goes off. When SCAN button is pressed, "AUTO" goes off.

\* 2

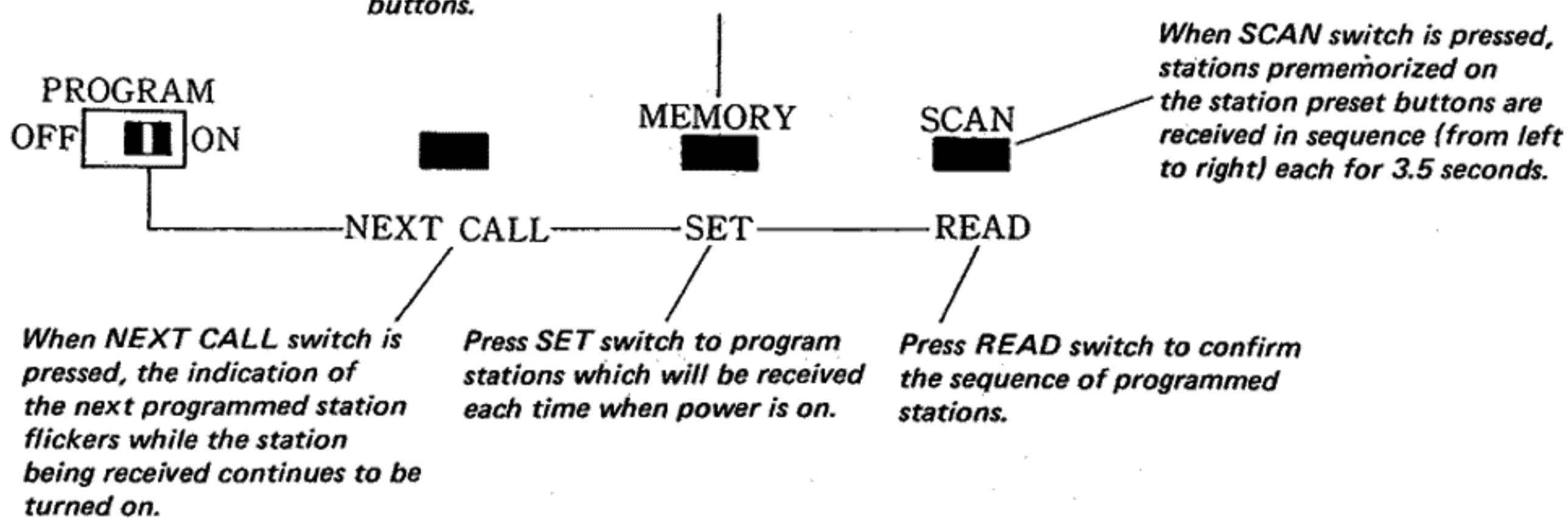

**Output Level Adjustment Setting**

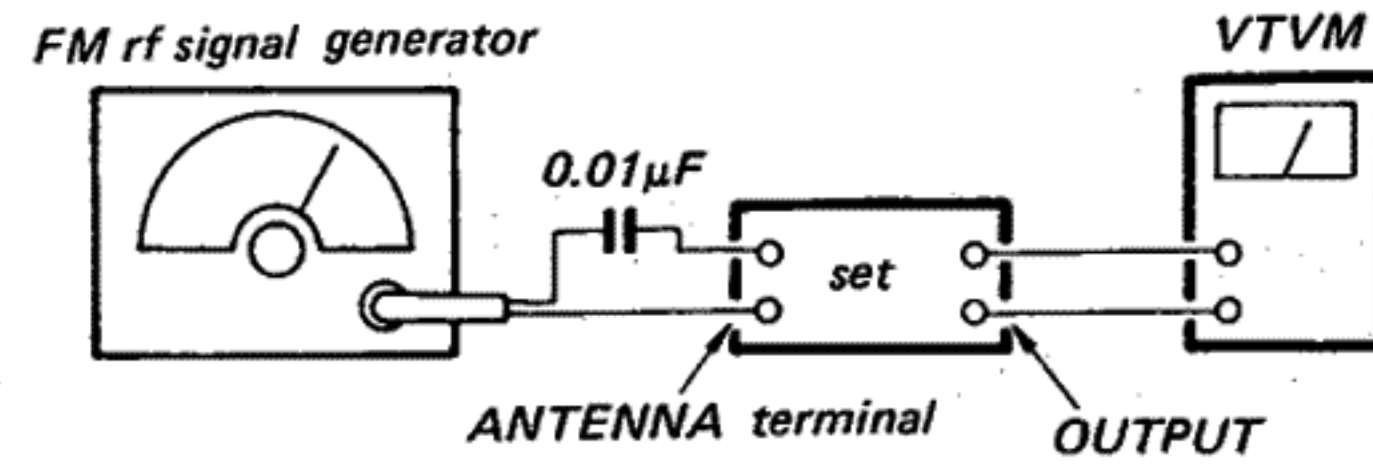

Output level: 1mV (60dB)

**Procedure:**

Adjust RT205 (L-CH) and RT206 (R-CH) for 0dB (0.775V) reading on VTVM.

FM rf Stereo Signal	FM rf Monaural Signal
Carrier frequency: 98MHz Modulation: Audio 400Hz, 33.75kHz deviation (45%) Subchannel 38kHz 33.75kHz deviation (45%) Pilot 19kHz 7.5kHz deviation (10%)	Carrier frequency: 98MHz Modulation: 400kHz deviation (100%)

**CAL TONE Level Adjustment Setting:**

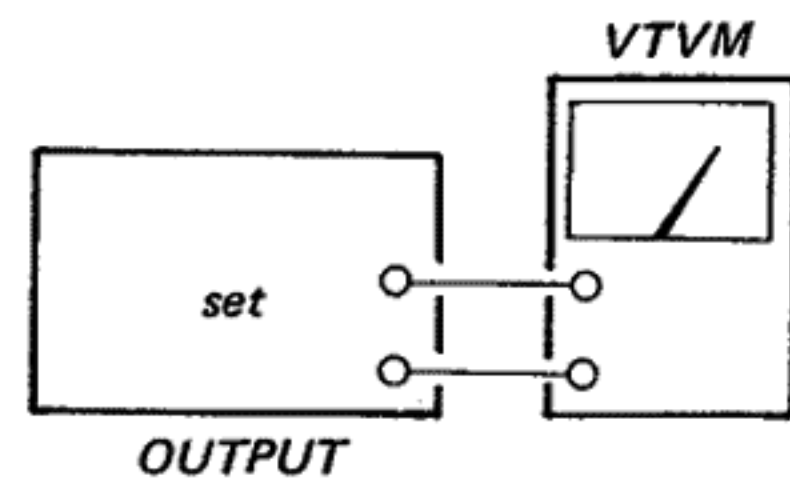

**Procedure:**

1. Press CAL TONE switch.
2. Adjust RT201 for -6dB (0.39V) reading on VTVM.

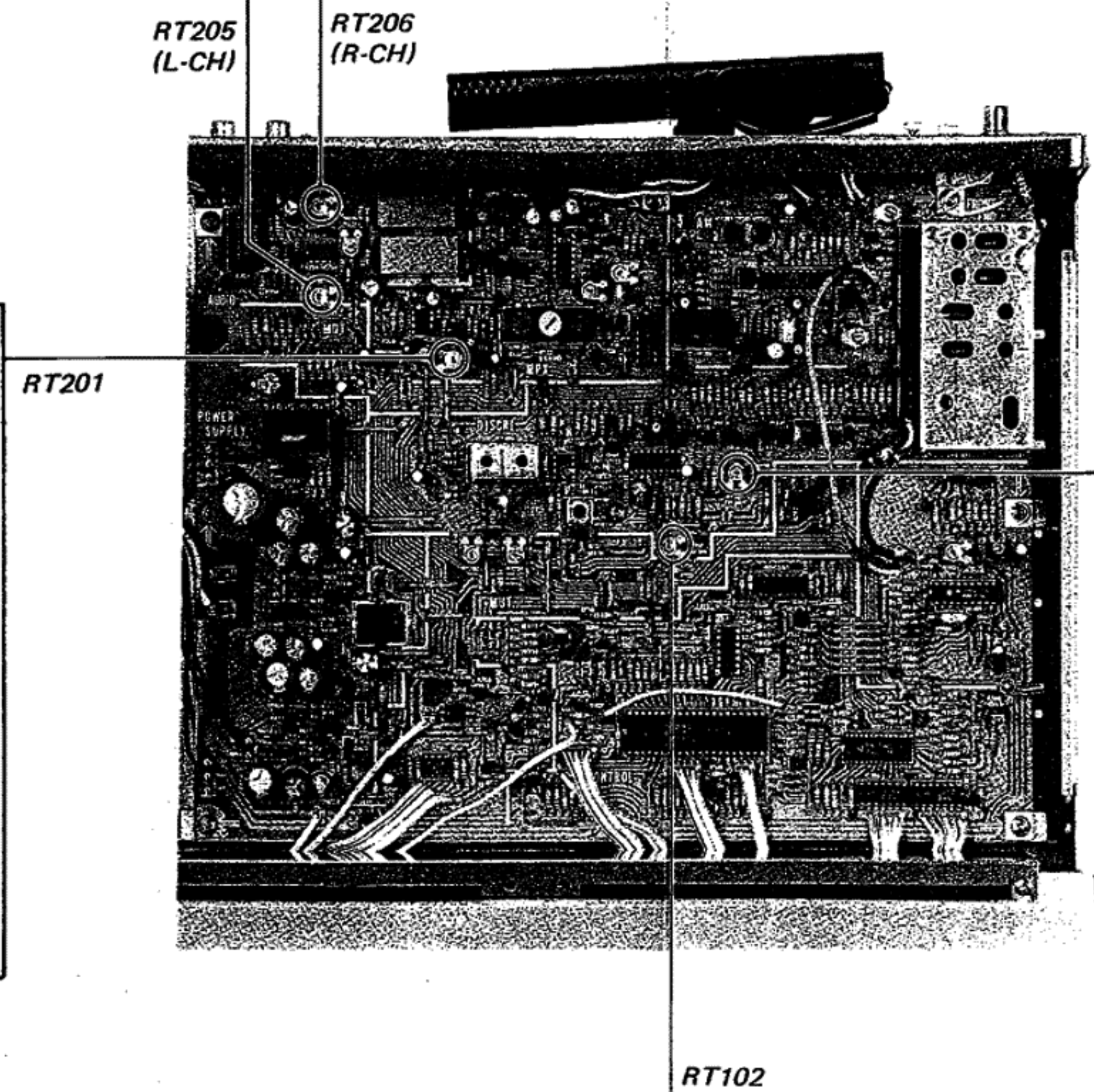

**FM Muting Level Adjustment Setting:**

**Setting:**

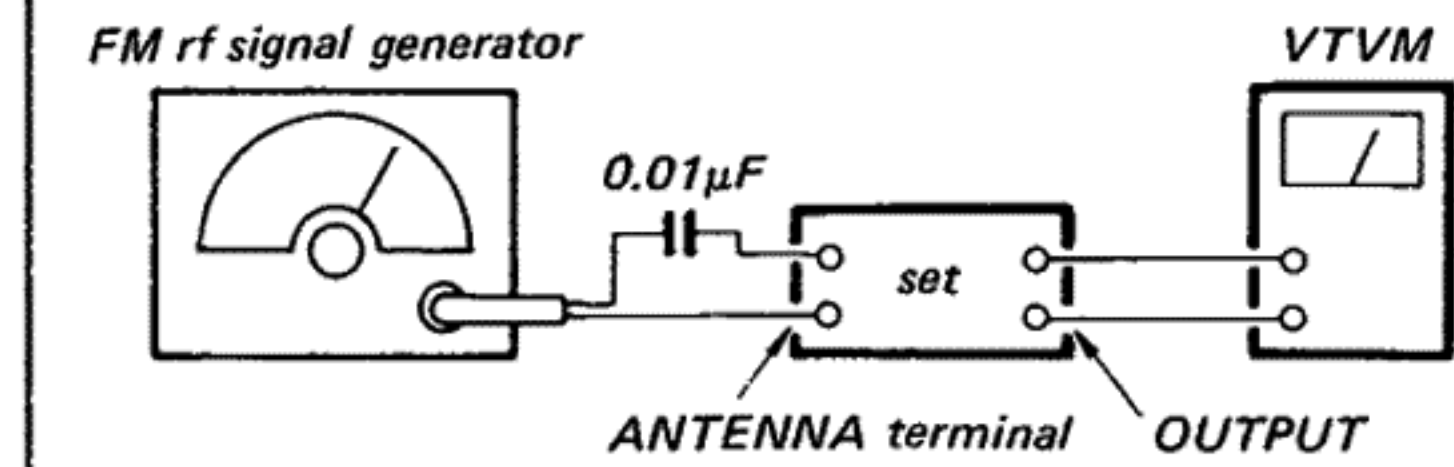

Output level: 10µV (20dB)

**Procedure:**

1. Indication: MUTING LOW
2. Tune the set to 98MHz by pressing the TUNING button (+, -) and adjust the output level at 20dB (10µV).
3. Turn RT101 and stop it just when the VTVM reading becomes suddenly 0V.

**Signal Indicator Adjustment Setting:**

**Setting:**

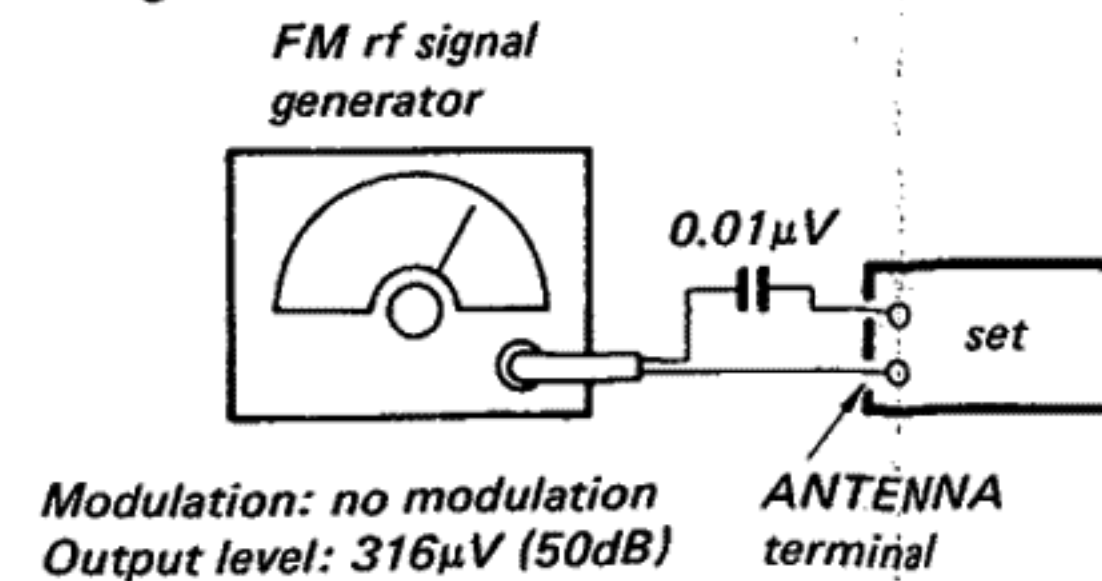

Modulation: no modulation  
Output level: 316µV (50dB)

**Procedure:**

Adjust RT102 so that all LEDs light up.

**Stereo Separation Adjustment**

**Procedure:**

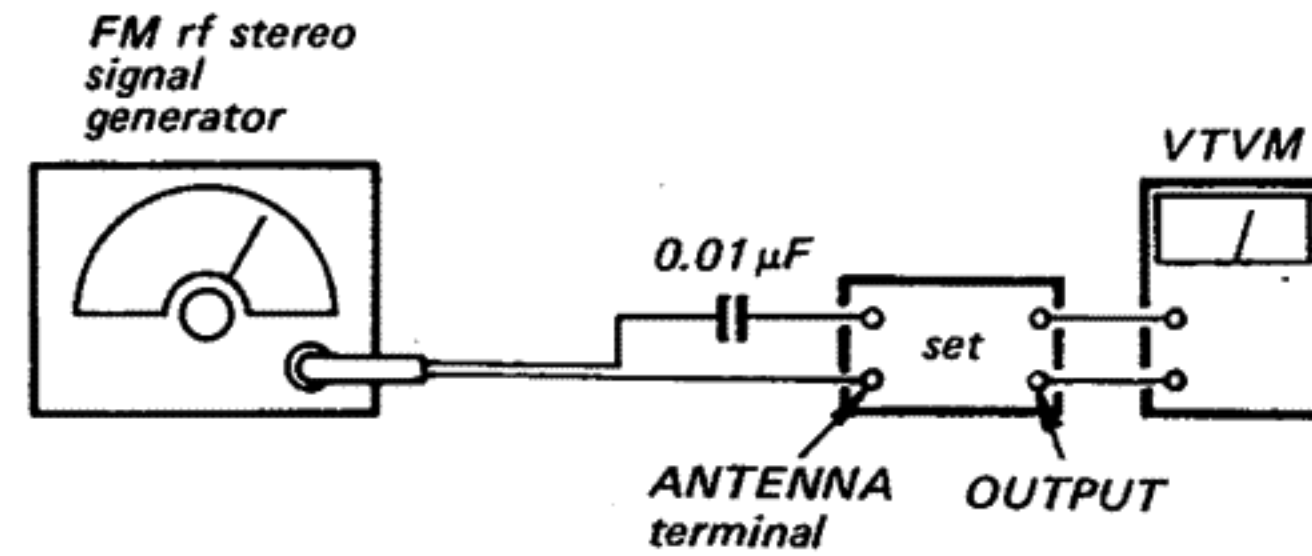

Carrier frequency: 98 MHz  
 Output level: 1 mV (60 dB)  
 Mode: Stereo  
 Modulation:  
 Audio (400 Hz): 33.75 kHz deviation (45%)  
 Pilot (19 kHz): 7.5 kHz deviation (10%)  
 Subchannel (38 kHz): 33.75 kHz deviation (45%)

FM stereo signal generator output channel	VTVM connection	VTVM reading (dB)
L-CH	L-CH	(A)
R-CH	L-CH	(B) Adjust RT204 for minimum reading.
R-CH	R-CH	(C)
L-CH	R-CH	(D) Adjust RT204 for minimum reading.

L-CH Stereo separation: (A) - (B)  
 R-CH Stereo separation: (C) - (D)

The separations of both channels should be equal.

**Pilot Cancel Adjustment**

**Procedure:**

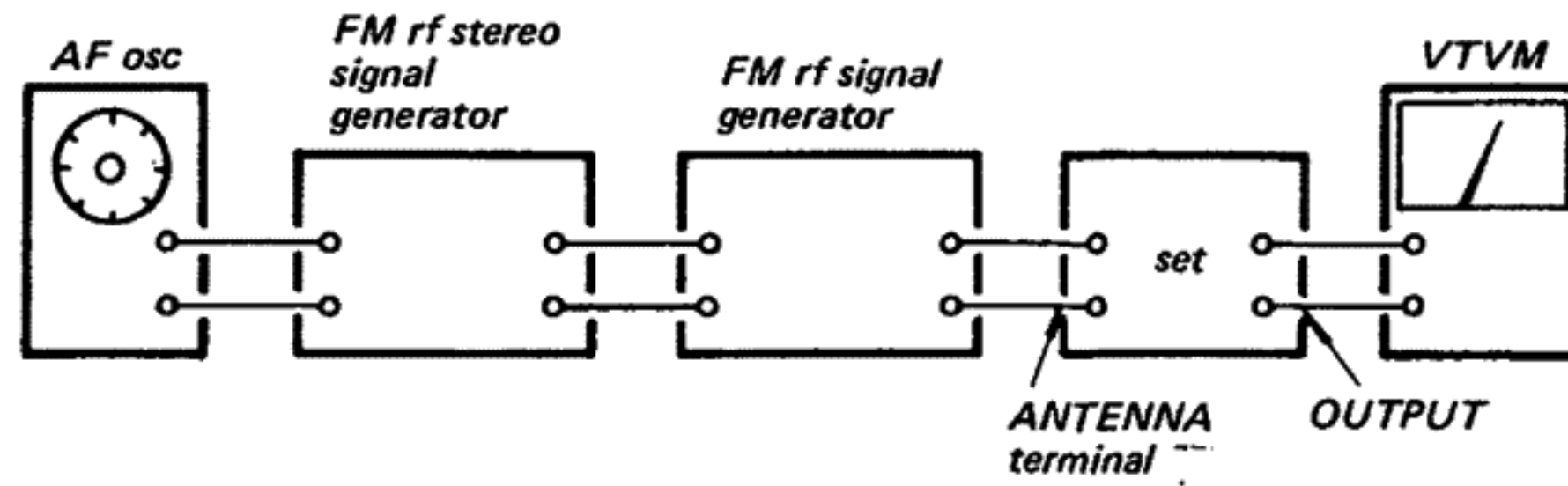

1. Repeat pressing the MUTING button until MUTING LOW indicator lights up.
2. Tune the set to 83MHz by pressing the TUNING switch and turn OFF the audio modulation (400Hz) of the FM stereo signal generator.
3. Adjust RT202 for minimum reading on the VTVM. Output level of both channels should be equal.

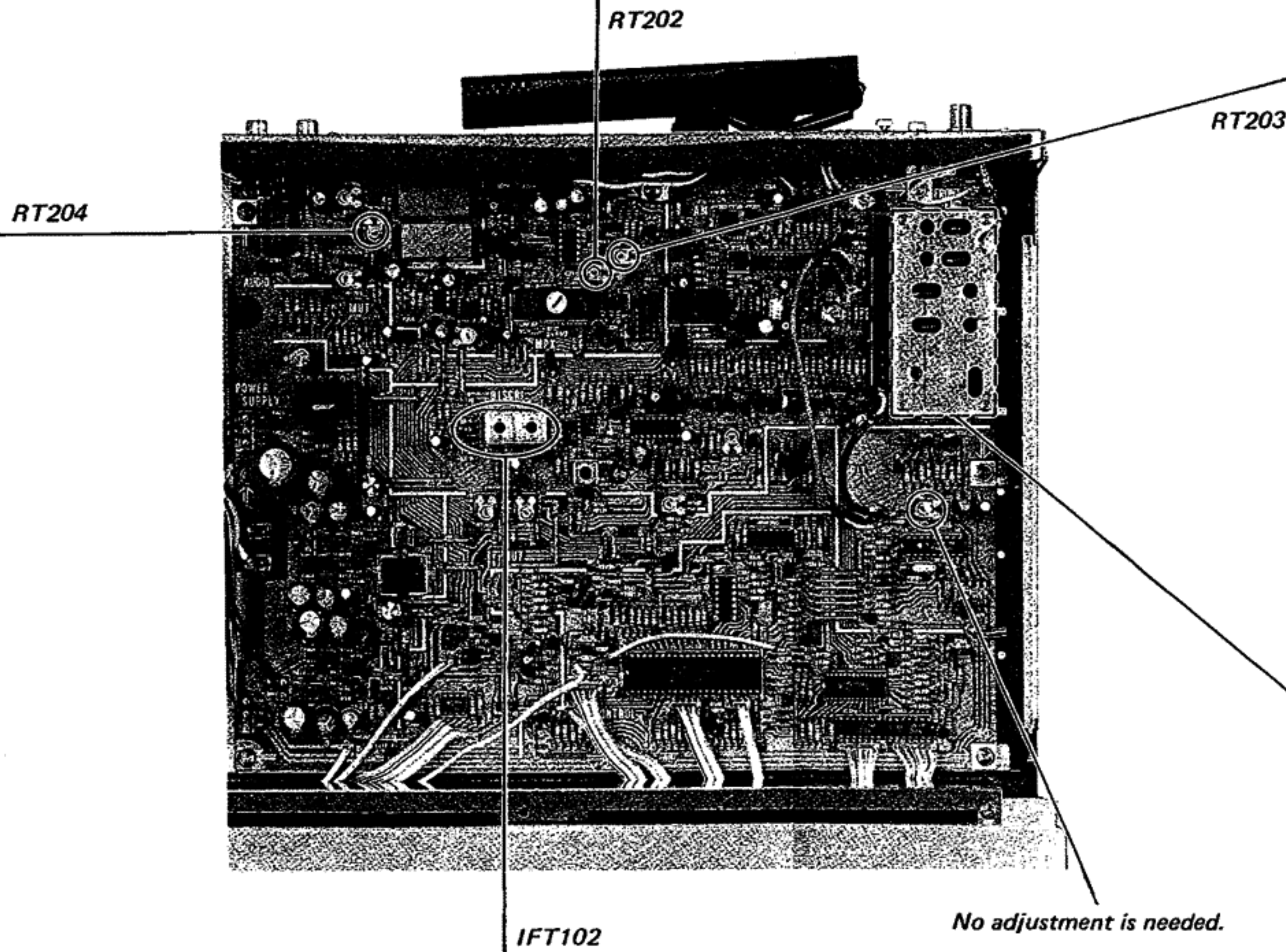

**VCO Adjustment**

**Setting:**

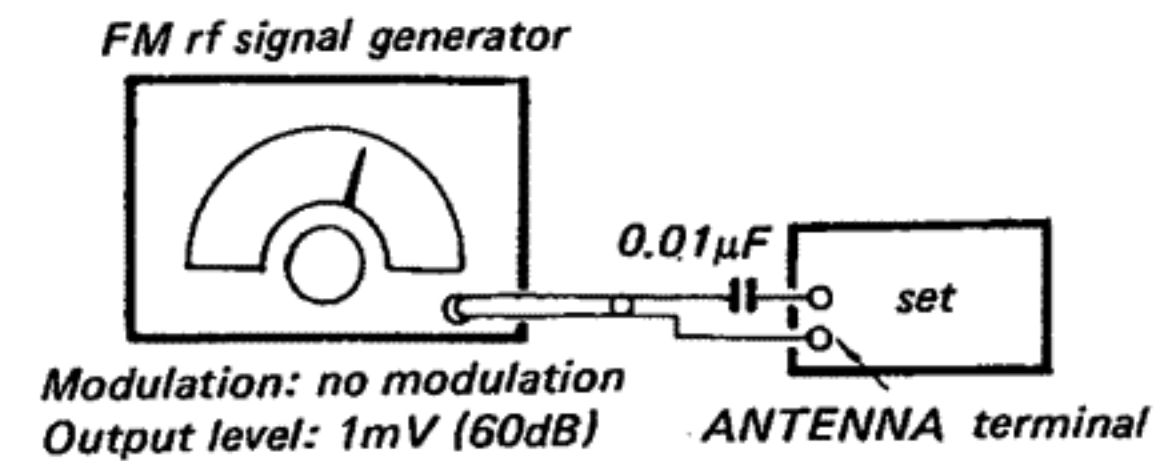

Modulation: no modulation  
 Output level: 1mV (60dB)

**Procedure:**

Adjust RT203 for 76kHz ±100Hz on the counter.

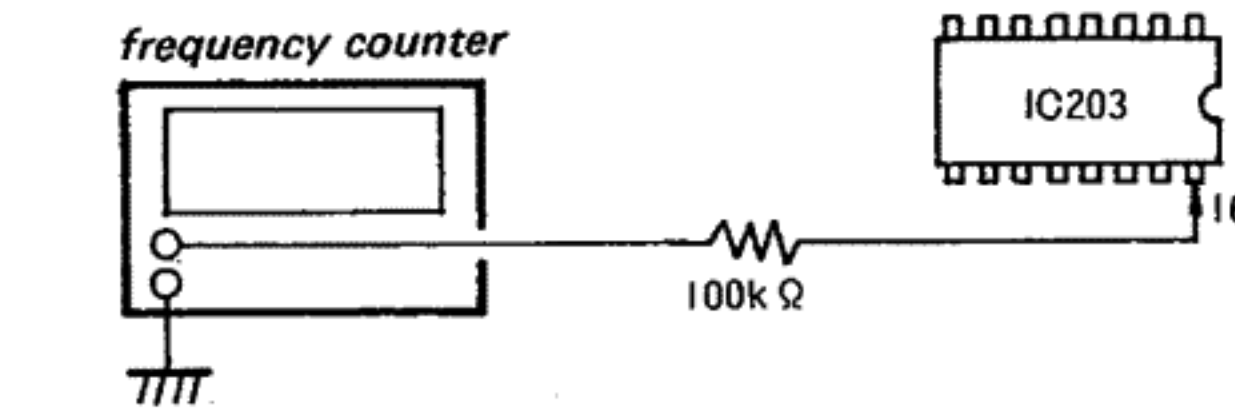

**Servicing Precaution**

The front-end section has been carefully adjusted at the factory. When it is worn out, be sure to exchange it all with new section, because it is difficult to repair.

**Discriminator Alignment**

**A) Secondary Side**

**Procedure:**

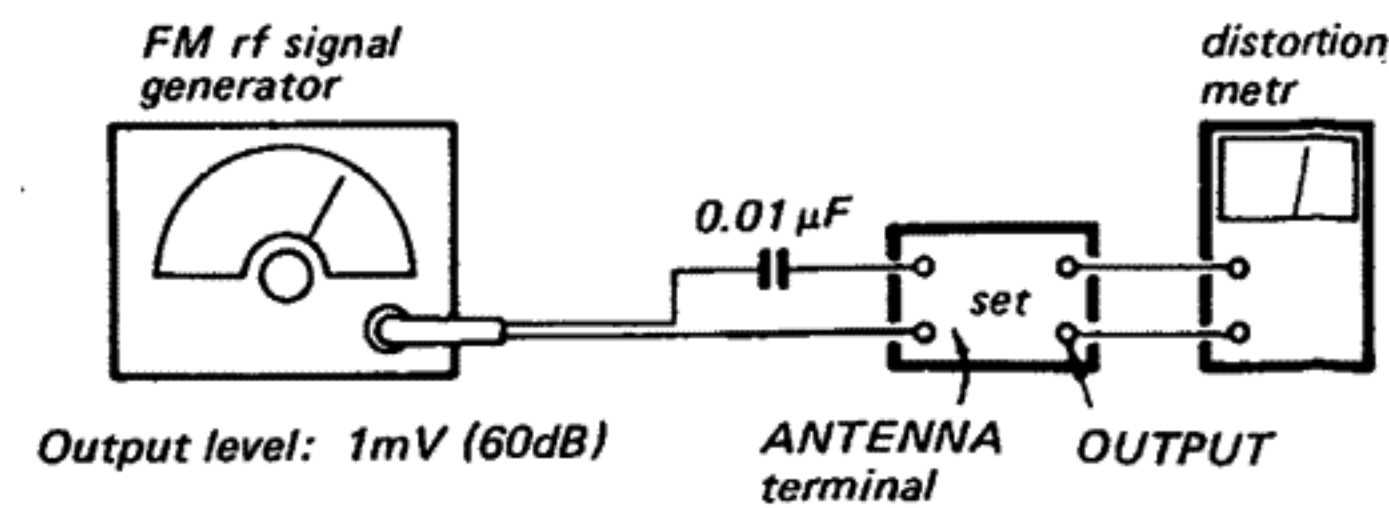

Output level: 1mV (60dB)

Turn the core (secondary side; black) of IFT102 for minimum distortion reading on the distortion meter.

**Note:** Repeat both secondary and primary sides adjustments several times.

**B) Primary Side**

**Procedure:**

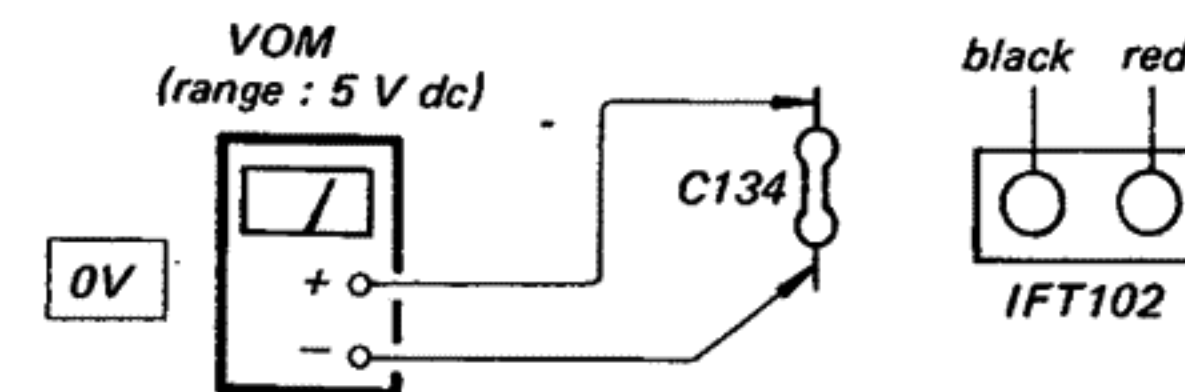

1. Press the TUNING switch to detune the set.
2. Turn the core (primary side: red) of IFT101 for 0V reading on VOM.

**Note:** When the ceramic filter is replaced, these adjustments should be made.



4-2. SCHEMATIC DIAGRAM

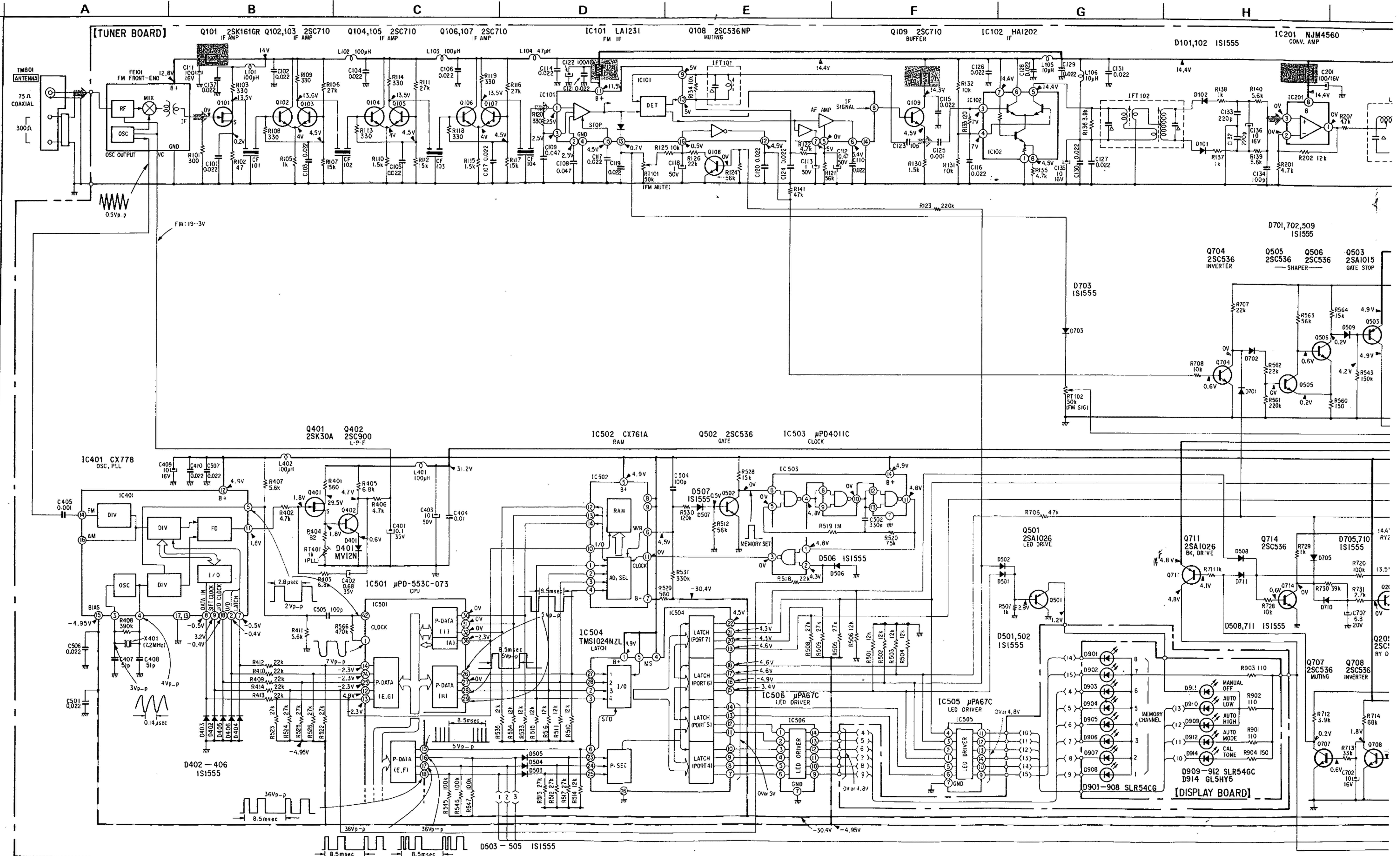





# SECTION 5 EXPLODED VIEWS

## Semiconductor Lead Layouts

<b>2SA1027R</b> 	<b>CX761A</b> <b>NPA67C</b> <b>TC4066BP</b> <b>μPD4011C</b> 	<b>GL5HY5</b> <b>SLR54GC</b> <b>SLR54GG</b> <b>SLR54URC</b> 
<b>2SB731</b> 	<b>CX778</b> 	<b>MV12N</b> 
<b>2SC536SP</b> <b>2SC1362</b> <b>2SC1364</b> 	<b>HA1202</b> <b>HA11223W</b> <b>LA1231</b> 	<b>SLP241B</b> 
<b>2SC710</b> 	<b>NJM4560D</b> <b>TL489CP</b> 	
<b>2SC1986</b> 	<b>TMS1024N2L</b> 	
<b>2SD809</b> 	<b>μPD553C-073</b> 	
<b>2SK30A-GR3</b> 		
<b>2SK161</b> 	<b>EQB01-06</b> <b>EQB01-15</b> <b>HZ6B1L</b> 	

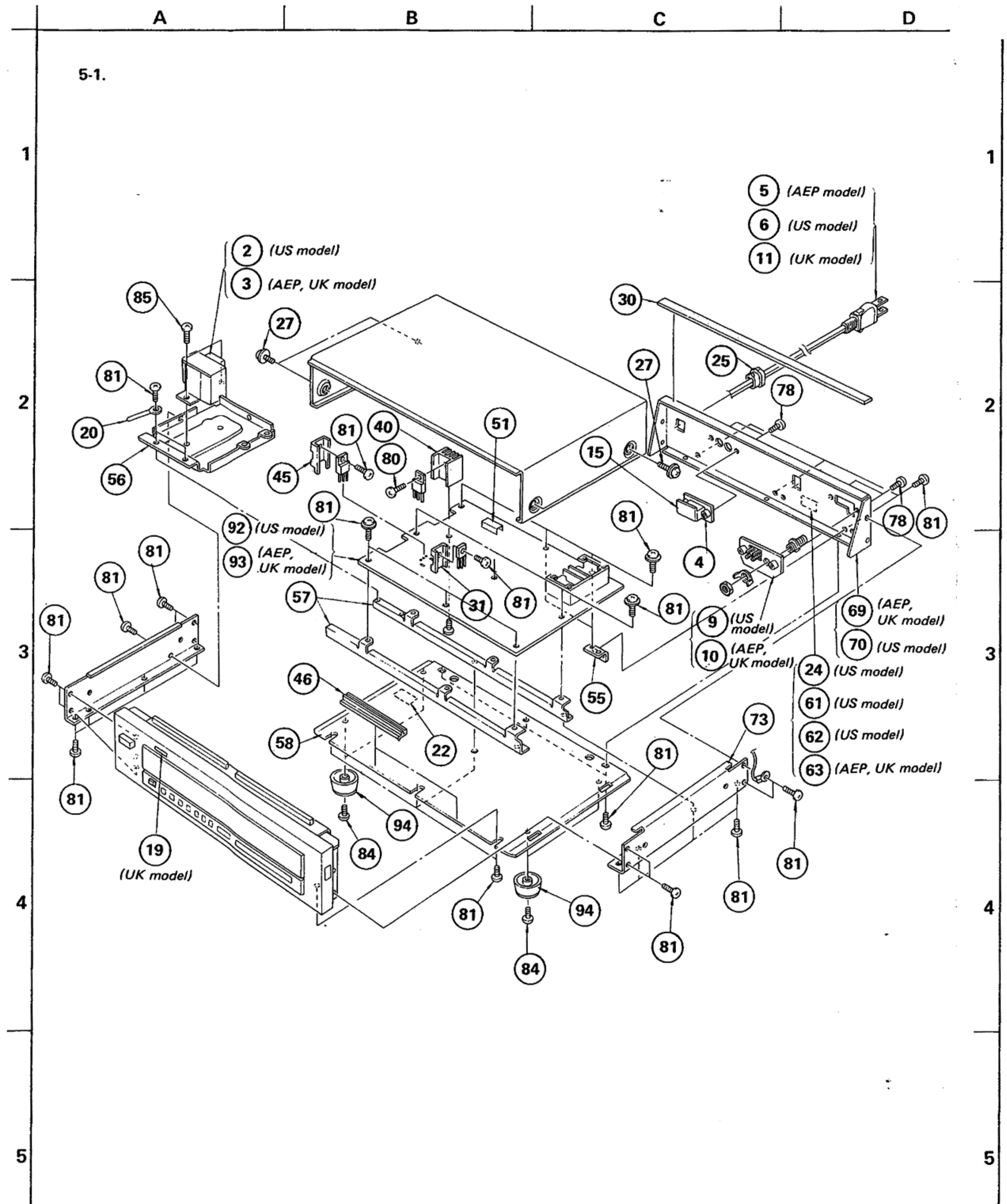



GENERAL SECTION

No.	Part No.	Description
1	△-1-231-326-11	ENCAPSULATED COMPONENT, CP801***(USA)
2	△-1-446-904-00	TRANSFORMER, POWER****(USA)
3	△-1-446-905-00	TRANSFORMER, POWER****(AEP,UK)
4	1-507-699-00	JACK, PIN 2P
5	△-1-534-817-99	CORD, POWER****(AEP)
6	△-1-534-986-XX	CORD, POWER****(USA)
7	*****	
8	*****	
9	1-536-652-00	TERMINAL BOARD (ANT)***(AEP,UK)
10	1-536-653-00	TERMINAL BOARD (ANT)***(USA)
11	△-1-551-884-00	CORD, POWER****(UK)
12	♣:1-560-062-00	PIN, CONNECTOR 4P
13	♣:1-603-254-00	PC BOARD, DISPLAY
14	♣:1-603-256-00	PC BOARD, SWITCH (B)
15	♣:1-603-257-00	PC BOARD, PIN JACK
16	♣:1-603-910-00	PC BOARD, POWER SWITCH
17	3-558-428-21	KNOB, SLIDE
18	*****	
19	3-701-690-01	LABEL (MADE IN JAPAN)***(UK)
20	3-701-822-00	HOLDER, WIRE
21	3-703-043-21	LABEL, MAIN-CAUTION****(UK)
22	*****	
23	3-703-079-21	LABEL, SUB-CAUTION****(USA)
24	3-703-208-11	LABEL, IDENTIFICATION*** (USA)
25	3-703-244-00	BUSHING, CORD
26	3-703-249-01	SCREW, S TIGHT, +PTWH 3X6
27	3-703-354-11	SCREW (OS), CASE, CLAW
28	*****	
29	3-831-441-XX	CUSHION (A)
30	4-848-642-00	CUSHION, VIBRATION
31	♣:4-861-002-00	HEAT SINK
32	4-861-701-00	HOLDER, DIAL SCALE
33	4-861-708-11	PLATE, SIDE
34	4-861-709-11	PLATE (A), SIDE
35	4-861-735-00	ILLUMINATOR*****(AEP,UK)
36	*****	
37	4-861-765-00	ILLUMINATOR,(S)*****(USA)
38	4-862-326-00	EMBLEM, QUARTZ
39	4-862-338-00	RING, STOPPER
40	♣:4-863-132-00	HEAT SINK (SMALL)
41	4-866-357-00	WINDOW, DIGITAL
42	4-866-397-00	CUSHION, LED
43	4-866-603-11	KNOB, PUSH
44	4-866-604-00	JOINT, PUSH KNOB
45	♣:4-866-647-00	HEAT SINK

GENERAL SECTION

No.	Part No.	Description
46	♣:4-866-702-00	RETAINER (A), PC BOARD
47	4-866-705-11	KNOB (C)
48	4-866-706-11	KNOB (B)
49	4-866-707-00	SPRING, COMPRESSION
50	♣:4-866-711-00	HOLDER, LED
51	♣:4-866-725-00	PLATE (A), SHIELD
52	4-866-728-00	INDICATOR, STATION (F-1)
53	4-866-738-00	INDICATOR, STATION(E-1)**(AEP,UK)
54	4-866-739-00	INDICATOR, STATION(E-2)**(AEP,UK)
55	♣:4-866-740-00	BRACKET, CHASSIS
56	♣:4-866-741-00	BASE, TRANSFORMER
57	♣:4-866-745-00	CHANNEL (A)
58	♣:4-866-746-00	PLATE, BOTTOM
59	♣:4-866-747-00	COVER, SHIELD
60	4-866-748-00	INDICATOR, STATION(E)****(AEP,UK)
61	4-871-302-00	LABEL, MODEL NUMBER****(USA)
62	4-871-302-00	LABEL, SPECIFICATION****(USA)
63	4-871-303-00	LABEL, SPECIFICATION****(UK)
64	♣:4-871-305-00	WINDOW, INDICATION
65	4-871-308-00	PANEL, INDICATION
66	4-871-309-00	HOLDER (A), LED
67	4-871-313-00	WINDOW, LARGE
68	4-871-315-00	BRACKET, INDICATION PANEL
69	4-871-318-00	PLATE, JACK*****(AEP,UK)
70	4-871-319-00	PLATE, JACK****(USA)
71	♣:4-871-320-00	CHASSIS, SUB
72	4-871-321-00	LABEL, SPECIFICATION****(AEP)
73	♣:4-871-326-00	PLATE, SIDE
74	♣:4-871-328-00	PLATE, INDICATION, PROGRAM
75	4-893-632-11	CASE
76	7-621-775-10	SCREW +B 2.6X4
77	7-682-647-01	SCREW +PS 3X6
78	7-685-647-29	SCREW +BVTP 3X10 TYPE2 SLIT
79	*****	
80	7-685-871-01	SCREW +BVTT 3X6 (S)
81	7-685-871-01	SCREW +BVTT 3X6 (S)
82	*****	
83	*****	
84	7-685-872-01	SCREW +BVTT 3X8 (S)
85	7-685-880-09	SCREW +BVTT 4X6 (S)
86	9-911-839-XX	RUBBER (A)
87	9-911-840-XX	RUBBER (B)
88	9-911-841-XX	SPACER
89	9-911-845-XX	CUSHION
90	*****	

NOTE:

- Items with no part number and no description are not stocked because they are seldom required for routine service.
- Items marked " ♣ " are not stocked since they are seldom required for routine service. Some delay should be anticipated when ordering these items.
- Due to standardization, parts with part numbers (△-△△△-△△△-XX or △-△△△△-△△△-X) may be different from those used in the set.

CAPACITORS:

- All capacitors are in  $\mu\text{F}$ . Common capacitors are omitted. Refer to the following lists for their part numbers. MF: $\mu\text{F}$ , PF: $\mu\mu\text{F}$ .

RESISTORS

- All resistors are in ohms. Common 1/4W, 1/8W and 1/16W carbon resistors are omitted. Refer to the following lists for their part numbers.

- F : nonflammable

The components identified by shading and mark  are critical for safety. Replace only with part number specified.

COILS

- MMH : mH, UH :  $\mu\text{H}$

GENERAL SECTION

No.	Part No.	Description
91	A-4322-299-A	PANEL ASSY
92	♣:A-4351-219-A	MOUNTED PCB, TUNER***** (USA)
93	♣:A-4351-220-A	MOUNTED PCB, TUNER***** (AEP, UK)
94	X-4861-312-0	FOOT ASSY, MF
95	A-4447-064-A	KNOB ASSY, POWER

ACCESSORY & PACKING MATERIAL

Part No.	Description
(USA)	
1-501-161-00	ANTENNA, FEEDER
1-506-305-00	F PLUG (FP-33)
1-551-734-11	CORD, CONNECTION (RK- 74A)
3-701-620-00	BAG, POLYETHYLENE
3-701-630-00	BAG, POLYETHYLENE
4-863-543-00	CUSHION
4-866-728-00	INDICATOR, STATION (F-1)
4-871-333-00	SHEET, PROTECTION
4-871-335-00	INDIVIDUAL CARTON
(UK)	
1-501-161-00	ANTENNA, FEEDER
1-551-734-11	CORD, CONNECTION (RK- 74A)
3-701-620-00	BAG, POLYETHYLENE
3-701-630-00	BAG, POLYETHYLENE
4-863-543-00	CUSHION
4-866-738-00	INDICATOR, STATION
4-866-739-00	INDICATOR, STATION (E-2)
4-871-333-00	SHEET, PROTECTION
4-871-335-00	INDIVIDUAL CARTON
(AEP)	
1-501-161-00	ANTENNA, FEEDER
1-551-734-11	CORD, CONNECTION (RK- 74A)
3-701-360-00	LABEL; TACK
3-701-620-00	BAG, POLYETHYLENE
3-701-630-00	BAG, POLYETHYLENE
4-863-543-00	CUSHION
4-866-738-00	INDICATOR, STATION
4-866-739-00	INDICATOR, STATION (E-2)
4-871-333-00	SHEET, PROTECTION
4-871-335-00	INDIVIDUAL CARTON

NOTE:

- Items with no part number and no description are not stocked because they are seldom required for routine service.
- Items marked "♣" are not stocked since they are seldom required for routine service. Some delay should be anticipated when ordering these items.
- Due to standardization, parts with part numbers (Δ-ΔΔΔ-ΔΔΔ-XX or Δ-ΔΔΔΔ-ΔΔΔ-X) may be different from those used in the set.

CAPACITORS:

- All capacitors are in μF. Common capacitors are omitted. Refer to the following lists for their part numbers. MF:μF, PF:μμF.

RESISTORS

- All resistors are in ohms. Common 1/4W, 1/8W and 1/16W carbon resistors are omitted. Refer to the following lists for their part numbers.

- F : nonflammable

The components identified by shading and mark  are critical for safety. Replace only with part number specified.

COILS

- MMH : mH, UH : μH

## ELECTRICAL PARTS

Ref.No.	Part No.	Description
C601	▲ 1-123-350-00	ELECT 220MF 20% 35V
C606	▲ 1-123-323-00	ELECT .470MF 20% 16V
C609	▲ 1-123-323-00	ELECT .470MF 20% 16V
C612	▲ 1-123-376-00	ELECT 330MF 20% 63V
C616	▲ 1-123-376-00	ELECT 330MF 20% 63V
C801	▲ 1-130-456-11	FILM 0.022MF 250V (AEP,UK)
CF101	1-527-796-00	FILTER, CERAMIC***** (USA)
CF102	1-527-796-00	FILTER, CERAMIC***** (USA)
CF103	1-527-796-00	FILTER, CERAMIC***** (USA)
CF104	1-527-796-00	FILTER, CERAMIC***** (USA)
CF101	1-527-799-00	FILTER, CERAMIC***** (AEP,UK)
CF102	1-527-799-00	FILTER, CERAMIC***** (AEP,UK)
CF103	1-527-799-00	FILTER, CERAMIC***** (AEP,UK)
CF104	1-527-799-00	FILTER, CERAMIC***** (AEP,UK)
CP601A	1-102-394-00	CERAMIC 250V
CP602A	1-102-394-00	CERAMIC 250V
CP603A	1-102-394-00	CERAMIC 250V
CP604A	1-102-394-00	CERAMIC 250V
CP605A	1-102-394-00	CERAMIC 250V
D101	8-719-815-55	DIODE 1S1555
D102	8-719-815-55	DIODE 1S1555
D201	8-719-815-55	DIODE 1S1555
D401	8-719-912-00	DIODE MV-12N
D402	8-719-815-55	DIODE 1S1555
D403	8-719-815-55	DIODE 1S1555
D404	8-719-815-55	DIODE 1S1555
D405	8-719-815-55	DIODE 1S1555
D406	8-719-815-55	DIODE 1S1555
D501	8-719-815-55	DIODE 1S1555
D502	8-719-815-55	DIODE 1S1555
****	*****	
****	*****	
****	*****	
D506	8-719-815-55	DIODE 1S1555
D507	8-719-815-55	DIODE 1S1555
D508	8-719-815-55	DIODE 1S1555
D509	8-719-815-55	DIODE 1S1555
D512	8-719-815-55	DIODE 1S1555
D601	8-719-200-02	DIODE 10E-2
D602	8-719-200-02	DIODE 10E-2
D603	8-719-910-65	DIODE HZ6B1L
D604	8-719-200-02	DIODE 10E-2
D605	8-719-200-02	DIODE 10E-2
D606	8-719-910-65	DIODE HZ6B1L
D607	8-719-200-02	DIODE 10E-2
D608	8-719-200-02	DIODE 10E-2
D609	8-719-910-65	DIODE HZ6B1L
D610	8-719-200-02	DIODE 10E-2
D611	8-719-200-02	DIODE 10E-2
D612	8-719-931-30	DIODE EQB01-30

## ELECTRICAL PARTS

Ref.No.	Part No.	Description
D613	8-719-931-15	DIODE EQB01-15
D614	8-719-200-02	DIODE 10E-2
D615	8-719-200-02	DIODE 10E-2
D616	8-719-913-02	DIODE HZ30-2L
D617	8-719-931-06	DIODE EQB01-06
D701	8-719-815-55	DIODE 1S1555
D702	8-719-815-55	DIODE 1S1555
****	*****	
****	*****	
D706	8-719-815-55	DIODE 1S1555
D707	8-719-815-55	DIODE 1S1555
D709	8-719-815-55	DIODE 1S1555
****	*****	
D711	8-719-815-55	DIODE 1S1555
D729	8-719-815-55	DIODE 1S1555
D801	8-719-815-55	DIODE 1S1555
D901	8-719-900-48	DIODE SLR54GG
D902	8-719-900-48	DIODE SLR54GG
D903	8-719-900-48	DIODE SLR54GG
D904	8-719-900-48	DIODE SLR54GG
D905	8-719-900-48	DIODE SLR54GG
D906	8-719-900-48	DIODE SLR54GG
D907	8-719-900-48	DIODE SLR54GG
D908	8-719-900-48	DIODE SLR54GG
D909	8-719-905-45	DIODE SLR54GC
D910	8-719-905-45	DIODE SLR54GC
D911	8-719-905-45	DIODE SLR54GC
D912	8-719-905-45	DIODE SLR54GC
D913	8-718-905-40	DIODE SLR54URC
D914	8-719-900-57	DIODE GL5HY5
D915	8-719-922-41	DIODE SLP241B
D916	8-719-922-41	DIODE SLP241B
D917	8-719-922-41	DIODE SLP241B
D918	8-719-922-41	DIODE SLP241B
D919	8-719-922-41	DIODE SLP241B
D920	8-719-815-55	DIODE 1S1555
D921	8-719-815-55	DIODE 1S1555
D922	8-719-815-55	DIODE 1S1555
D923	8-719-815-55	DIODE 1S1555
D924	8-719-815-55	DIODE 1S1555
D925	8-719-815-55	DIODE 1S1555
D926	8-719-815-55	DIODE 1S1555
D927	8-719-815-55	DIODE 1S1555
FE101	1-463-346-00	FRONT END
FE901	1-519-208-00	INDICATOR TUBE, FLUORESCENT
IC101	8-759-812-31	IC LA1231
IC102	8-759-312-02	IC HA1202
IC201	8-759-745-60	IC NJM4560D
IC202	8-759-240-66	IC TC4066BP
IC203	8-759-312-23	IC HA11223W

## NOTE:

- Items with no part number and no description are not stocked because they are seldom required for routine service.
- Items marked "▲" are not stocked since they are seldom required for routine service. Some delay should be anticipated when ordering these items.
- Due to standardization, parts with part numbers (▲-▲▲▲-▲▲▲-XX or ▲-▲▲▲-▲▲▲-X) may be different from those used in the set.

## CAPACITORS:

- All capacitors are in  $\mu$ F. Common capacitors are omitted. Refer to the following lists for their part numbers.  
MF: $\mu$ F, PF: $\mu$ F.

## RESISTORS

- All resistors are in ohms. Common 1/4W, 1/8W and 1/16W carbon resistors are omitted. Refer to the following lists for their part numbers.

- F : nonflammable

The components identified by shading and mark ▲ are critical for safety. Replace only with part number specified.

## COILS

- MMH : mH, UH :  $\mu$ H

## ELECTRICAL PARTS

Ref.No.	Part No.	Description
IC204	8-759-745-60	IC NJM4560D
IC401	8-759-607-78	IC CX-778
IC501	8-759-153-73	IC UPD553C-073
IC502	8-757-611-00	IC CX-761A
IC503	8-759-140-11	IC UPD4011C
IC504	8-759-990-23	IC TMS1024N2L
IC505	8-759-100-67	IC UPA67C
IC506	8-759-100-67	IC UPA67C
IC701	8-759-904-89	IC TL489CP
IIFT101	1-404-312-00	TRANSFORMER, IF
IIFT102	1-404-250-00	TRANSFORMER, DISCRIMINATOR
L101	1-407-169-XX	MICRO INDUCTOR 100UH
L102	1-407-169-XX	MICRO INDUCTOR 100UH
L103	1-407-169-XX	MICRO INDUCTOR 100UH
L104	1-407-165-XX	MICRO INDUCTOR 47UH
L105	1-407-190-00	MICRO INDUCTOR 10UH
L106	1-407-190-00	MICRO INDUCTOR 10UH
L401	1-407-169-XX	MICRO INDUCTOR 100UH
L402	1-407-169-XX	MICRO INDUCTOR 100UH
LPF201	1-231-422-00	FILTER, LOWPASS
LPF202	1-231-421-00	FILTER, LOWPASS
LPF203	1-231-421-00	FILTER, LOWPASS
Q101	8-729-216-13	TRANSISTOR 2SK161
Q102	8-729-671-14	TRANSISTOR 2SC710-13
Q103	8-729-671-14	TRANSISTOR 2SC710-13
Q104	8-729-671-14	TRANSISTOR 2SC710-13
Q105	8-729-671-14	TRANSISTOR 2SC710-13
Q106	8-729-671-14	TRANSISTOR 2SC710-13
Q107	8-729-671-14	TRANSISTOR 2SC710-13
Q108	8-729-803-63	TRANSISTOR 2SC536SP
Q109	8-729-671-13	TRANSISTOR 2SC710-13
Q203	8-729-663-47	TRANSISTOR 2SC1364
Q204	8-729-663-47	TRANSISTOR 2SC1364
Q205	8-729-803-63	TRANSISTOR 2SC536SP
Q401	8-729-203-05	TRANSISTOR 2SK30A-GR3
Q402	8-729-665-47	TRANSISTOR 2SC1362
Q501	8-729-612-77	TRANSISTOR 2SA1027R
Q502	8-729-853-63	TRANSISTOR 2SC536SP
Q503	8-729-612-77	TRANSISTOR 2SA1027R
Q504	8-729-853-63	TRANSISTOR 2SC536SP
Q505	8-729-853-63	TRANSISTOR 2SC536SP
Q506	8-729-853-63	TRANSISTOR 2SC536SP
Q507	8-729-853-63	TRANSISTOR 2SC536SP
Q601	8-729-382-62	TRANSISTOR 2SC1986
Q602	8-729-663-47	TRANSISTOR 2SC1364
Q603	8-729-663-47	TRANSISTOR 2SC1364
Q604	8-729-173-13	TRANSISTOR 2SB731

## NOTE:

- Items with no part number and no description are not stocked because they are seldom required for routine service.
- Items marked "▲" are not stocked since they are seldom required for routine service. Some delay should be anticipated when ordering these items.
- Due to standardization, parts with part numbers (Δ-ΔΔΔ-ΔΔΔ-XX or Δ-ΔΔΔΔ-ΔΔΔ-X) may be different from those used in the set.

## CAPACITORS:

- All capacitors are in  $\mu\text{F}$ . Common capacitors are omitted. Refer to the following lists for their part numbers. MF: $\mu\text{F}$ , PF: $\mu\text{F}$ .

## RESISTORS

- All resistors are in ohms. Common 1/4W, 1/8W and 1/16W carbon resistors are omitted. Refer to the following lists for their part numbers.

- F : nonflammable

## ELECTRICAL PARTS

Ref.No.	Part No.	Description
Q605	8-729-382-61	TRANSISTOR 2SC1986
Q606	8-729-180-93	TRANSISTOR 2SD809
Q607	8-729-173-13	TRANSISTOR 2SB731
Q608	8-729-180-93	TRANSISTOR 2SD809
Q704	8-729-853-63	TRANSISTOR 2SC536SP
Q706	8-729-853-63	TRANSISTOR 2SC536SP
Q707	8-729-853-63	TRANSISTOR 2SC536SP
Q708	8-729-853-63	TRANSISTOR 2SC536SP
Q709	8-729-612-77	TRANSISTOR 2SA1027R
Q710	8-729-612-77	TRANSISTOR 2SA1027R
Q711	8-729-612-77	TRANSISTOR 2SA1027R
Q712	8-729-853-63	TRANSISTOR 2SC536SP
Q713	8-729-853-63	TRANSISTOR 2SC536SP
Q714	8-729-853-63	TRANSISTOR 2SC536SP
Q715	8-729-663-47	TRANSISTOR 2SC1364
R104	▲1-247-097-00	CARBON 39 5% 1/4W F
R129	▲1-247-083-00	CARBON 10 5% 1/4W F
R208	▲1-247-107-00	CARBON 100 5% 1/4W F
R209	▲1-247-107-00	CARBON 100 5% 1/4W F
R219	▲1-247-109-00	CARBON 230 5% 1/4W F
R229	▲1-247-107-00	CARBON 100 5% 1/4W F
R233	▲1-247-107-00	CARBON 100 5% 1/4W F
R234	▲1-247-097-00	CARBON 39 5% 1/4W F
R601	▲1-247-079-00	CARBON 4.7 5% 1/4W F
R607	▲1-247-083-00	CARBON 10 5% 1/4W F
R610	▲1-247-083-00	CARBON 10 5% 1/4W F
R613	▲1-247-083-00	CARBON 10 5% 1/4W F
R617	▲1-247-083-00	CARBON 10 5% 1/4W F
R801	▲1-202-725-00	COMPOSITION 3.3M 10% 1/2W*** (USA)
RT101	1-226-238-00	RES, ADJ, CARBON 50K
RT102	1-226-238-00	RES, ADJ, CARBON 50K
RT201	1-226-238-00	RES, ADJ, CARBON 50K
RT202	1-226-238-00	RES, ADJ, CARBON 50K
RT203	1-226-235-00	RES, ADJ, CARBON 5K
RT204	1-226-239-00	RES, ADJ, CARBON 100K
RT205	1-226-237-00	RES, ADJ, CARBON 20K
RT206	1-226-237-00	RES, ADJ, CARBON 20K
RT401	1-226-233-00	RES, ADJ, CARBON 1K
RY201	1-515-297-00	RELAY, REED
S801	▲1-553-318-00	SWITCH, PUSH (POWER)**** (AEP,UK)
S801	▲1-553-319-00	SWITCH, PUSH (POWER)**** (USA)
S802	1-553-428-00	SWITCH, SLIDE
S901	1-552-539-00	SWITCH, KEY BOARD
S902	1-552-539-00	SWITCH, KEY BOARD
S903	1-552-539-00	SWITCH, KEY BOARD
S905	1-552-539-00	SWITCH, KEY BOARD
S906	1-552-539-00	SWITCH, KEY BOARD
S907	1-552-539-00	SWITCH, KEY BOARD
S908	1-552-539-00	SWITCH, KEY BOARD

The components identified by shading and mark ▲ are critical for safety. Replace only with part number specified.

## COILS

- MMH : mH, UH :  $\mu\text{H}$

ELECTRICAL PARTS

<u>Ref.No.</u>	<u>Part No.</u>	<u>Description</u>
S909	1-552-539-00	SWITCH, KEY BOARD
S910	1-552-539-00	SWITCH, KEY BOARD
S911	1-552-539-00	SWITCH, KEY BOARD
S912	1-552-539-00	SWITCH, KEY BOARD
S913	1-552-539-00	SWITCH, KEY BOARD
S914	1-552-539-00	SWITCH, KEY BOARD
S915	1-552-539-00	SWITCH, KEY BOARD
S916	1-552-539-00	SWITCH, KEY BOARD
S917	1-552-539-00	SWITCH, KEY BOARD
VS801A	1-552-963-00	VOLTEGE SELECTER****(AEP,UK)
X401	1-527-731-00	OSCILLATOR, CRYSTAL

### ELECTROLYTIC CAPACITORS

RATING							→ : Use the high voltage rated one.
CAP. (μF)	6.3 VOLT.	10 VOLT.	16 VOLT.	25 VOLT.	35 VOLT.	50 VOLT.	
	PART No.	PART No.	PART No.	PART No.	PART No.	PART No.	PART No.
0.47							1-121-726-00
1.0							1-121-391-00
2.2							1-121-450-00
3.3	→	→	→	1-121-392-00			1-121-393-00
4.7	→	→	→	1-121-395-00			1-121-396-00
10	→	→	1-121-651-00	1-121-398-00			1-121-738-00
22	→	→	1-121-479-00	1-121-480-00	1-121-662-00		1-121-152-00
33	→	→	1-121-403-00	1-121-404-00	1-121-652-00		1-121-405-00
47	→	1-121-352-00	1-121-409-00	1-121-410-00	1-121-653-00		1-121-411-00
100	→	1-121-414-00	1-121-415-00	1-121-416-00	1-121-357-00		1-121-417-00
220	1-121-415-00	1-121-420-00	1-121-421-00	1-121-422-00	1-121-261-00		1-121-423-00
330	1-121-751-00	1-121-805-00	1-121-521-00	1-121-654-00	1-121-655-00		1-121-656-00
470	1-121-424-00	1-121-425-00	1-121-426-00	1-121-733-00	1-121-361-00		1-121-810-00
1000	-	1-121-736-00	1-121-245-00	1-121-657-00	1-121-388-00		1-123-061-00
2200	1-121-658-00	1-121-659-00	1-121-660-00	1-123-067-00	1-121-984-00		-
3300	1-121-661-00	1-123-075-00	1-123-071-00	-	-		-

CAP. (μF)	100 VOLT.	160 VOLT.	250 VOLT.	350 VOLT.
	PART No.	PART No.	PART No.	PART No.
0.47	-	-	-	-
1.0	1-123-249-00	1-123-252-00	1-123-003-00	1-121-168-00
2.2	1-123-250-00	1-123-026-00	-	1-123-028-00
3.3	1-121-995-00	-	1-123-004-00	1-123-006-00
4.7	1-123-255-00	1-121-246-00	1-121-759-00	1-123-007-00
10	1-121-126-00	1-121-999-00	1-123-254-00	1-123-008-00
22	1-121-996-00	1-123-253-00	1-123-005-00	1-123-022-00
33	1-121-997-00	1-121-757-00	-	-
47	1-123-251-00	1-121-919-00	-	-
100	1-123-084-00	-	-	-

### CERAMIC CAPACITORS

RATING							
CAP. (pF)	50 VOLT.	CAP. (pF)	50 VOLT.	CAP. (pF)	50 VOLT.	CAP. (μF)	50 VOLT.
	PART No.		PART No.		PART No.		PART No.
0.5	1-101-837-00	22	1-102-959-00	150	1-101-361-00	0.001	1-102-074-00
0.75	1-101-586-00	24	1-102-960-00	160	1-101-367-00	0.0012	1-102-118-00
1.0	1-102-934-00	27	1-102-961-00	180	1-102-976-00	0.0015	1-102-119-00
1.5	1-101-576-00	30	1-102-962-00	200	1-102-977-00	0.0018	1-102-120-00
2.0	1-102-935-00	33	1-102-963-00	220	1-102-978-00	0.0022	1-102-121-00
3	1-102-936-00	36	1-102-964-00	240	1-102-979-00	0.0027	1-102-122-00
4	1-102-937-00	39	1-102-965-00	270	1-102-980-00	0.0033	1-102-123-00
5	1-102-942-00	43	1-102-966-00	300	1-102-981-00	0.0039	1-102-124-00
6	1-102-943-00	47	1-101-880-00	330	1-102-820-00	0.0047	1-102-125-00
7	1-102-944-00	51	1-101-882-00	360	1-102-821-00	0.0056	1-102-126-00
8	1-102-945-00	56	1-101-884-00	390	1-102-822-00	0.0068	1-102-127-00
9	1-102-946-00	62	1-101-886-00	430	1-102-823-00	0.0082	1-102-128-00
10	1-102-947-00	68	1-101-888-00	470	1-102-824-00	0.01	1-102-129-00
11	1-102-948-00	75	1-101-890-00	510	1-101-059-00	0.022	1-101-005-00
12	1-102-949-00	82	1-102-971-00	560	1-102-115-00	0.047	1-101-006-00
13	1-102-950-00	91	1-102-972-00	680	1-102-116-00		
15	1-102-951-00	100	1-102-973-00	820	1-102-117-00		
16	1-102-952-00	110	1-102-815-00				
18	1-102-953-00	120	1-102-816-00				
20	1-102-958-00	130	1-101-081-00				

0.001μF = 1,000pF

### CERAMIC (SEMICONDUCTOR) CAPACITORS

RATING						→ : Use the high voltage rated one.
CAP. (μF)	25 VOLT.	50 VOLT.	CAP. (μF)	25 VOLT.	50 VOLT.	
	PART No.	PART No.		PART No.	PART No.	
0.001	→	1-161-039-00	0.018	1-161-016-00	1-161-054-00	
0.0012	→	1-161-040-00	0.022	1-161-017-00	1-161-055-00	
0.0015		1-161-041-00	0.027	1-161-018-00	1-161-056-00	
0.0018		1-161-042-00	0.033	1-161-019-00	1-161-057-00	
0.0022		1-161-043-00	0.039	1-161-010-00	1-161-058-00	
0.0027	→	1-161-044-00	0.047	1-161-021-00	1-161-059-00	
0.0033	→	1-161-045-00	0.056	→	1-161-060-00	
0.0039	→	1-161-046-00	0.068	→	1-161-061-00	
0.0047	→	1-161-047-00	0.082	1-161-024-00	1-161-062-00	
0.0056	→	1-161-048-00	0.1	1-161-025-00	1-161-063-00	
0.0068	→	1-161-049-00				
0.0082	1-161-012-00	1-161-050-00				
0.01	1-161-013-00	1-161-051-00				
0.012	→	1-161-052-00				
0.015	1-161-015-00	1-161-053-00				



**MYLAR CAPACITORS**

		RATING									
CAP. (μF)	50 VOLT.	100 VOLT.	200 VOLT.	CAP. (μF)	50 VOLT.	100 VOLT.	200 VOLT.	CAP. (μF)	50 VOLT.	100 VOLT.	200 VOLT.
	PART No.	PART No.	PART No.		PART No.	PART No.	PART No.		PART No.	PART No.	PART No.
0.001	1-108-227-00	1-108-365-00	1-108-409-00	0.01	1-108-239-00	1-108-377-00	1-108-421-00	0.1	1-108-251-00	1-108-389-00	1-108-433-00
0.0012	1-108-351-00	1-108-366-00	1-108-410-00	0.012	1-108-357-00	1-108-378-00	1-108-422-00	0.12	1-108-363-00	1-108-390-00	1-108-434-00
0.0015	1-108-228-00	1-108-367-00	1-108-411-00	0.015	1-108-240-00	1-108-379-00	1-108-423-00	0.15	1-108-252-00	1-108-391-00	1-108-435-00
0.0018	1-108-352-00	1-108-368-00	1-108-412-00	0.018	1-108-358-00	1-108-380-00	1-108-424-00	0.18	1-108-364-00	1-108-392-00	1-108-436-00
0.0022	1-108-230-00	1-108-369-00	1-108-413-00	0.022	1-108-242-00	1-108-381-00	1-108-425-00	0.22	1-108-254-00	1-108-393-00	1-108-437-00
0.0027	1-108-353-00	1-108-370-00	1-108-414-00	0.027	1-108-359-00	1-108-382-00	1-108-426-00	0.27	1-108-854-00	-	-
0.0033	1-108-232-00	1-108-371-00	1-108-415-00	0.033	1-108-244-00	1-108-383-00	1-108-427-00	0.33	1-108-855-00	-	-
0.0039	1-108-354-00	1-108-372-00	1-108-416-00	0.039	1-108-360-00	1-108-384-00	1-108-428-00	0.39	1-108-856-00	-	-
0.0047	1-108-234-00	1-108-373-00	1-108-417-00	0.047	1-108-246-00	1-108-385-00	1-108-429-00	0.47	1-108-857-00	-	-
0.0056	1-108-355-00	1-108-374-00	1-108-418-00	0.056	1-108-361-00	1-108-386-00	1-108-430-00				
0.0068	1-108-237-00	1-108-375-00	1-108-419-00	0.068	1-108-249-00	1-108-387-00	1-108-431-00				
0.0082	1-108-356-00	1-108-376-00	1-108-420-00	0.082	1-108-362-00	1-108-388-00	1-108-432-00				

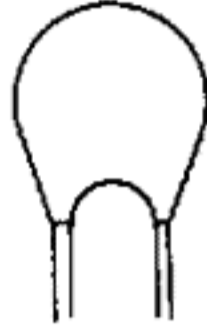

**TANTALUM CAPACITORS**

		RATING						→: Use the high voltage rated one.	
CAP. (μF)	3.15 VOLT.	6.3 VOLT.	10 VOLT.	16 VOLT.	20 VOLT.	25 VOLT.	35 VOLT.		
	PART No.	PART No.	PART No.	PART No.	PART No.	PART No.	PART No.	PART No.	
0.01					→	→		1-131-396-00	
0.015						→		1-131-397-00	
0.022						→		1-131-398-00	
0.033						→		1-131-399-00	
0.047						→		1-131-400-00	
0.068					→	→		1-131-401-00	
0.1					→	→		1-131-402-00	
0.15					→	→		1-131-403-00	
0.22					→	→		1-131-404-00	
0.33					→	1-131-409-00		1-131-405-00	
0.47	-	-	-	-	1-131-412-00	→		1-131-406-00	
0.68	-	-	-	1-131-415-00	→	1-131-410-00		1-131-407-00	
1.0	-	-	1-131-418-00	-	1-131-413-00	→		1-131-408-00	
1.5	-	1-131-421-00	-	1-131-416-00	→	1-131-411-00		1-131-348-00	
2.2	1-131-424-00	-	1-131-419-00	-	1-131-414-00	1-131-355-00		1-131-349-00	
3.3	-	1-131-422-00	-	1-131-417-00	1-131-362-00	1-131-356-00		1-131-350-00	
4.7	1-131-425-00	-	1-131-420-00	1-131-369-00	1-131-363-00	1-131-357-00		1-131-351-00	
6.8	-	1-131-423-00	1-131-376-00	1-131-370-00	1-131-364-00	1-131-358-00		1-131-352-00	
10	1-131-426-00	1-131-383-00	1-131-377-00	1-131-371-00	1-131-365-00	1-131-359-00		1-131-353-00	
15	1-131-390-00	1-131-384-00	1-131-378-00	1-131-372-00	1-131-366-00	1-131-360-00		-	
22	1-131-391-00	1-131-385-00	1-131-379-00	1-131-373-00	1-131-367-00				
33	1-131-392-00	1-131-386-00	1-131-380-00	1-131-374-00					
47	1-131-393-00	1-131-387-00	1-131-381-00	-					
68	1-131-394-00	1-131-388-00	-	-					
100	1-131-395-00	-	-	-					

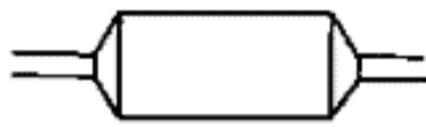

**TANTALUM CAPACITORS**

		RATING				
CAP. (μF)	3 VOLT.	6.3 VOLT.	10 VOLT.	16 VOLT.	20 VOLT.	35 VOLT.
	PART No.	PART No.	PART No.	PART No.	PART No.	PART No.
0.033						1-131-273-00
0.047						1-131-274-00
0.068						1-131-275-00
0.1						1-131-276-00
0.15						1-131-277-00
0.22					1-131-262-00	1-131-278-00
0.33					1-131-263-00	1-131-279-00
0.47			1-131-169-00		1-131-264-00	1-131-280-00
0.68				1-131-258-00	1-131-265-00	1-131-281-00
1.0			1-131-254-00		1-131-266-00	1-131-282-00
1.5		1-131-250-00			1-131-267-00	1-131-283-00
2.2				1-131-259-00	1-131-268-00	1-131-284-00
3.3			1-131-255-00		1-131-269-00	-
4.7		1-131-251-00	1-131-171-00		1-131-270-00	-
6.8				1-131-260-00	1-131-271-00	-
10			1-131-256-00		1-131-272-00	-
15		1-131-252-00		1-131-261-00		
22			1-131-257-00			
33	1-131-176-00	1-131-253-00	1-131-173-00			
47	1-131-288-00	1-131-174-00				
100	1-131-177-00					

## 1/4 WATT CARBON RESISTORS

Ω	Part No.	Ω	Part No.	Ω	Part No.	Ω	Part No.	Ω	Part No.	Ω	Part No.	Ω	Part No.
1.0	1-246-401-00	10	1-246-425-00	100	1-246-449-00	1.0k	1-246-473-00	10k	1-246-497-00	100k	1-246-521-00	1.0M	1-246-545-00
1.1	1-246-402-00	11	1-246-426-00	110	1-246-450-00	1.1k	1-246-474-00	11k	1-246-498-00	110k	1-246-522-00	1.1M	1-210-814-00
1.2	1-246-403-00	12	1-246-427-00	120	1-246-451-00	1.2k	1-246-475-00	12k	1-246-499-00	120k	1-246-523-00	1.2M	1-210-815-00
1.3	1-246-404-00	13	1-246-428-00	130	1-246-452-00	1.3k	1-246-476-00	13k	1-246-500-00	130k	1-246-524-00	1.3M	1-210-816-00
1.5	1-246-405-00	15	1-246-429-00	150	1-246-453-00	1.5k	1-246-477-00	15k	1-246-501-00	150k	1-246-525-00	1.5M	1-210-817-00
1.6	1-246-406-00	16	1-246-430-00	160	1-246-454-00	1.6k	1-246-478-00	16k	1-246-502-00	160k	1-246-526-00	1.6M	1-210-818-00
1.8	1-246-407-00	18	1-246-431-00	180	1-246-455-00	1.8k	1-246-479-00	18k	1-246-503-00	180k	1-246-527-00	1.8M	1-210-819-00
2.0	1-246-408-00	20	1-246-432-00	200	1-246-456-00	2.0k	1-246-480-00	20k	1-246-504-00	200k	1-246-528-00	2.0M	1-210-820-00
2.2	1-246-409-00	22	1-246-433-00	220	1-246-457-00	2.2k	1-246-481-00	22k	1-246-505-00	220k	1-246-529-00	2.2M	1-210-821-00
2.4	1-246-410-00	24	1-246-434-00	240	1-246-458-00	2.4k	1-246-482-00	24k	1-246-506-00	240k	1-246-530-00	2.4M	1-244-754-00
2.7	1-246-411-00	27	1-246-435-00	270	1-246-459-00	2.7k	1-246-483-00	27k	1-246-507-00	270k	1-246-531-00	2.7M	1-244-755-00
3.0	1-246-412-00	30	1-246-436-00	300	1-246-460-00	3.0k	1-246-484-00	30k	1-246-508-00	300k	1-246-532-00	3.0M	1-244-756-00
3.3	1-246-413-00	33	1-246-437-00	330	1-246-461-00	3.3k	1-246-485-00	33k	1-246-509-00	330k	1-246-533-00	3.3M	1-244-757-00
3.6	1-246-414-00	36	1-246-438-00	360	1-246-462-00	3.6k	1-246-486-00	36k	1-246-510-00	360k	1-246-534-00	3.6M	1-244-758-00
3.9	1-246-415-00	39	1-246-439-00	390	1-246-463-00	3.9k	1-246-487-00	39k	1-246-511-00	390k	1-246-535-00	3.9M	1-244-759-00
4.3	1-246-416-00	43	1-246-440-00	430	1-246-464-00	4.3k	1-246-488-00	43k	1-246-512-00	430k	1-246-536-00	4.3M	1-244-760-00
4.7	1-246-417-00	47	1-246-441-00	470	1-246-465-00	4.7k	1-246-489-00	47k	1-246-513-00	470k	1-246-537-00	4.7M	1-244-761-00
5.1	1-246-418-00	51	1-246-442-00	510	1-246-466-00	5.1k	1-246-490-00	51k	1-246-514-00	510k	1-246-538-00	5.1M	1-244-762-00
5.6	1-246-419-00	56	1-246-443-00	560	1-246-467-00	5.6k	1-246-491-00	56k	1-246-515-00	560k	1-246-539-00		
6.2	1-246-420-00	62	1-246-444-00	620	1-246-468-00	6.2k	1-246-492-00	62k	1-246-516-00	620k	1-246-540-00		
6.8	1-246-421-00	68	1-246-445-00	680	1-246-469-00	6.8k	1-246-493-00	68k	1-246-517-00	680k	1-246-541-00		
7.5	1-246-422-00	75	1-246-446-00	750	1-246-470-00	7.5k	1-246-494-00	75k	1-246-518-00	750k	1-246-542-00		
8.2	1-246-423-00	82	1-246-447-00	820	1-246-471-00	8.2k	1-246-495-00	82k	1-246-519-00	820k	1-246-543-00		
9.1	1-246-424-00	91	1-246-448-00	910	1-246-472-00	9.1k	1-246-496-00	91k	1-246-520-00	910k	1-246-544-00		

### HARDWARE NOMENCLATURE

Screw:

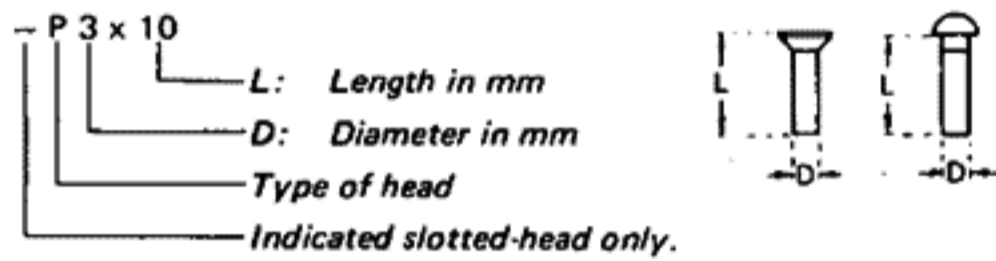

Unless otherwise indicated, it means cross-recessed head (Phillips type).

Nut, Washer, Retaining ring:

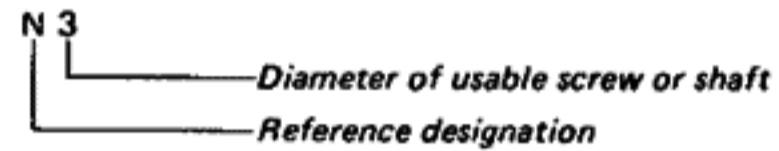

Reference Designation	Shape	Description	Remarks
<b>SCREWS</b>			
P		pan-head screw	binding-head (B) screw for replacement
PWH		pan-head screw with washer face	binding-head (B) screw and flat washer for replacement
PS PSP		pan-head screw with spring washer	binding-head (B) screw and spring washer for replacement
PSW PSPW		pan-head screw with spring and flat washers	binding-head (B) screw and spring and flat washers for replacement
R		round-head screw	binding-head (B) screw for replacement
K		flat-countersunk-head screw	
RK		oval-countersunk-head screw	
B		binding-head screw	
T		truss-head screw	binding-head (B) screw for replacement
F		flat-fillister-head screw	
RF		fillister-head screw	
BV		braizer-head screw	

Reference Designation	Shape	Description	Remarks
<b>SELF-TAPPING SCREWS</b>			
TA		self-tapping screw	ex: TA, P 3 x 10
PTP		pan-head self-tapping screw	binding-head self-tapping (TA, B) screw for replacement
PTPWH		pan-head self-tapping screw with washer face	binding-head self-tapping (TA, B) screw and flat washer for replacement
PTTWH		pan-head thread-rolling screw with washer face	binding-head (B) screw and flat washer for replacement
<b>SET SCREWS</b>			
SC		set screw	
SC		hexagon-socket set screw	ex: SC 2.6 x 4, hexagon socket
<b>NUT</b>			
N		nut	
<b>WASHERS</b>			
W		flat washer	
SW		spring washer	
LW		internal-tooth lock washer	ex: LW3, internal
LW		external-tooth lock washer	ex: LW3, external
<b>RETAINING RINGS</b>			
E		retaining ring	
G		grip-type retaining ring	

Sony Corporation