

# ST-JX295/JX390

## SERVICE MANUAL

US Model  
E Model

ST-JX295/JX390

Canadian Model  
ST-JX295

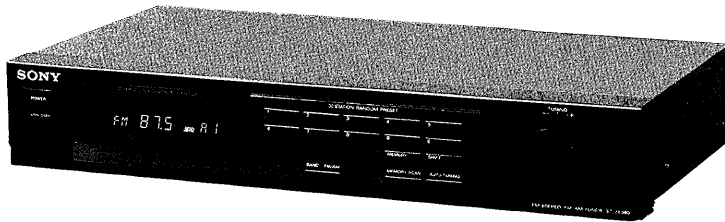

Photo: ST-JX390

ST-JX290: This set is the tuner section in  
SEN-290 (CND, E)/SEN-390 (US).

### SPECIFICATIONS

#### FM tuner

Frequency range 87.5 — 108 MHz  
Antenna terminal 300 ohms, balanced  
75 ohms, unbalanced  
IF 10.7 MHz  
Sensitivity

S/N 50 dB sensitive	Mono	22.1 dBf (7 $\mu$ V)
	Stereo	42.1 dBf (70 $\mu$ V)
Usable sensitivity (IHF)		19.5 dBf (5 $\mu$ V)

Signal-to-noise ratio 80 dB (mono), 75 dB (stereo)  
Harmonic distortion 0.3% (mono), 0.5% (stereo) at 1 kHz  
Separation 40 dB (1 kHz)  
Frequency response 30 Hz — 15 kHz  $\pm 2.0$  dB  
Selectivity 55 dB (400 kHz)  
AM suppression ratio 54 dB  
Image response ratio 50 dB  
IF response ratio 90 dB  
Spurious response ratio 70 dB  
Automatic tuning threshold 17.8  $\mu$ V (30 dBf)  
Output 775 mV, 4.7 kohms (at 75 kHz deviation) (ST-JX390)

#### AM tuner

Frequency range  $\left. \begin{array}{l} 530 - 1,710 \text{ kHz (10 kHz)} \\ 531 - 1,710 \text{ kHz (9 kHz)} \end{array} \right\}$  US/CA Model  
 $\left. \begin{array}{l} 530 - 1,710 \text{ kHz (10 kHz)} \\ 531 - 1,602 \text{ kHz (9 kHz)} \end{array} \right\}$  E Model  
Antenna Loop antenna, External antenna terminal  
IF 450 kHz  
Sensitivity (999 kHz or 1,000 kHz) 500  $\mu$ V/m (when the loop antenna is in use)  
Signal-to-noise ratio 54 dB (mono, normal)  
Harmonic distortion 0.5% (mono, normal)  
Selectivity 35 dB (9 kHz, normal)  
38 dB (10 kHz, normal)  
Frequency response 40 Hz — 3.5 kHz  $\pm 0$  dB (normal)

#### General

Power requirements 120 V AC, 60 Hz } ST-JX390  
Power consumption 8 W }  
Dimensions Approx. 430 x 80 x 260 mm (w/h/d)  
(17 x 3 1/4 x 10 1/4 inches)  
Weight Approx. 2.4 kg (5 lb 5 oz) (ST-JX390)  
Approx. 2.0 kg (4 lb 7 oz) (ST-JX295)

#### Supplied accessories (ST-JX390)

- Remote control cord (1)
- Connecting cord (1)
- FM wire antenna (1)
- AM loop antenna (1)

Sony Corporation Printed in

Design and specifications subject to change without notice.



## FM STEREO/FM-AM TUNER

# SONY®

## SAFETY CHECK-OUT

After correcting the original service problem, perform the following safety check before releasing the set to the customer:

Check the antenna terminals, metal trim, "metallized" knobs, screws, and all other exposed metal parts for AC leakage. Check leakage as described below.

### LEAKAGE TEST

The AC leakage from any exposed metal part to earth ground and from all exposed metal parts to any exposed metal part having a return to chassis, must not exceed 0.5 mA (500 microamperes). Leakage current can be measured by any one of three methods.

1. A commercial leakage tester, such as the Simpson 229 or RCA WT-540A. Follow the manufacturers' instructions to use these instruments.
2. A battery-operated AC milliammeter. The Data Precision 245 digital multimeter is suitable for this job.
3. Measuring the voltage drop across a resistor by means of a VOM or battery-operated AC voltmeter. The "limit" indication is 0.75 V, so analog meters must have an accurate low-voltage scale. The Simpson 250 and Sanwa SH-63Trd are examples of a passive VOM that is suitable. Nearly all battery operated digital multimeters that have a 2V AC range are suitable. (See Fig. A)

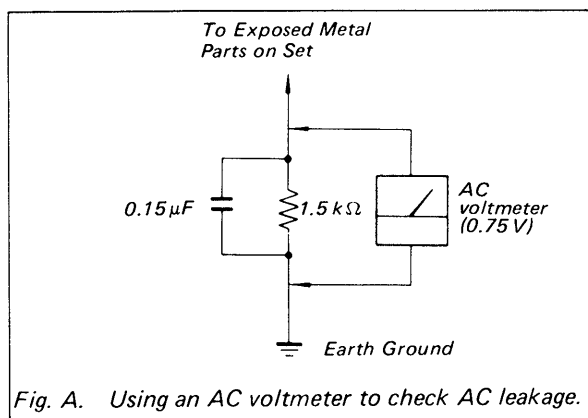

Fig. A. Using an AC voltmeter to check AC leakage.

## TABLE OF CONTENTS

<u>Section</u>	<u>Title</u>	<u>Page</u>
Specification .....		1
Safety Check-out .....		2
<b>1. GENERAL</b> .....		<b>3</b>
<b>2. ELECTRICAL ADJUSTMENT</b>		
FM Section .....		4
AM Section .....		4
<b>3. DIAGRAM</b>		
3-1. Block Diagram .....		5
3-2. Printed Wiring Boards .....		10
3-3. Schematic Diagram .....		15
<b>4. EXPLODED VIEWS</b> .....		<b>21</b>
<b>5. ELECTRICAL PARTS LIST</b> .....		<b>22</b>

### To change the AM tuning interval

The AM tuning interval is preset at the factory to 10 kHz to match the frequency allocation system of your country. To change the interval to 9 kHz, proceed as follows.

- 1 Depress the POWER switch to turn on the unit.
- 2 Set the BAND FM/AM selector to AM.
- 3 Press the POWER switch to turn off the unit.
- 4 Hold the TUNING knob in the "+" position, and depress the POWER switch to turn on the unit. To reset the interval to 10 kHz, follow the same procedure.

### Note

When the interval is changed, all preset stations which you have memorized using the numeric buttons will be erased from the memory. After changing the interval, be sure to preset the stations again.

SECTION 1  
GENERAL

**Storing Station Frequencies into Memory**

**1** Tune in a desired station.

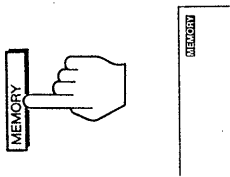

**2**

Allot one of the following codes:

- A-1, A-2, ... A-9,
- B-1, ... B-9,
- C-1, ... C-9, C-0

First, select alphabet.

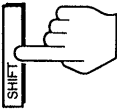

**3**

**4** Select number.

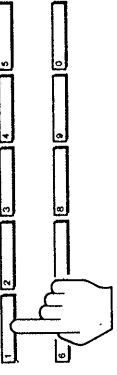

**Scanning Stored Stations — Memory Scanning**

**1**

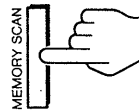

The code indication flashes in the window.

**2**

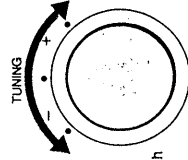

To scan stations with preceding codes.

Stored stations are tuned in successively.

**3**

As soon as the desired station is received:

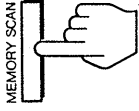

Scanning stops.

**More information on storing stations**

**How many stations can be stored?**

Up to 10 stations can be stored in any order for each alphabet (A, B, C). Therefore, 30 stations can be stored in total.

**If you cannot store a station successfully**

You can store a station only while "MEMORY" is displayed. If the "MEMORY" indication has gone off, press MEMORY again.

**More information on scanning stored stations**

**Which stations are skipped during memory scanning?**

The memory scan will skip stations which have a very weak signal.

**If you cannot scan successfully**

Turn the TUNING knob while the code indication is flashing. If the flashing has stopped, press MEMORY SCAN again.

## SECTION 2 ELECTRICAL ADJUSTMENT

### FM SECTION

#### • FM Discriminator Alignment (NULL check)

**Setting :**

FM RF stereo signal generator

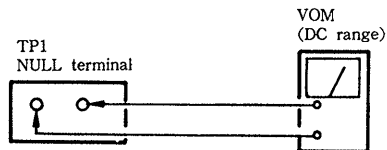
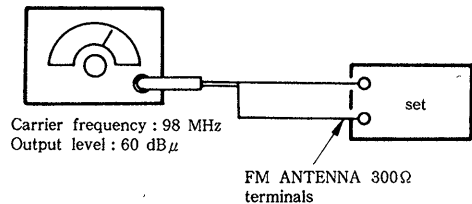

**Procedure :**

1. Tune the set to 98 MHz.
  2. Adjust T21 for 0 V reading on the VOM.
- Note :** FM TUNING LEVEL adjustment should be made after FM discriminator alignment.

#### • FM TUNING LEVEL Adjustment

**Setting :**

FM RF stereo signal generator

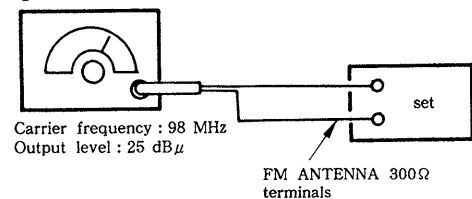

**Procedure :**

1. Tune the set to 98 MHz.
2. Adjust RV24 so that the TUNED LED goes on.

### AM SECTION

#### • AM Tuned Indication Lighting Level Adjustment

**Setting :**

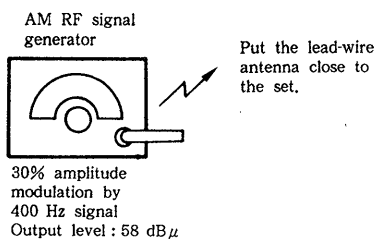

**Procedure :**

1. Tune the set to 1,050 kHz (US, CANADIAN), 999 kHz (E).
2. Adjust RV22 so that the TUNED LED goes on.

#### • FM Stereo Separation Adjustment

**Setting :**

FM RF stereo signal generator

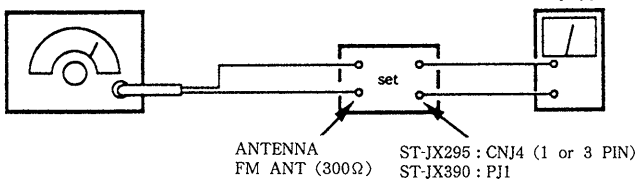

Carrier frequency : 98 MHz  
Output level : 60 dB $\mu$

**Procedure :**

Tune the set to 98 MHz.

FM stereo signal generator output channel	VTVM connection	VTVM reading (dB)
L-CH	L-CH	(A)
R-CH	L-CH	(B) Adjust RV21 for minimum reading.
R-CH	R-CH	(C)
L-CH	R-CH	(D) Adjust RV21 for minimum reading.

L-CH Stereo separation : (A) - (B)  
R-CH Stereo separation : (C) - (D)

The separations of both channels should be equal.

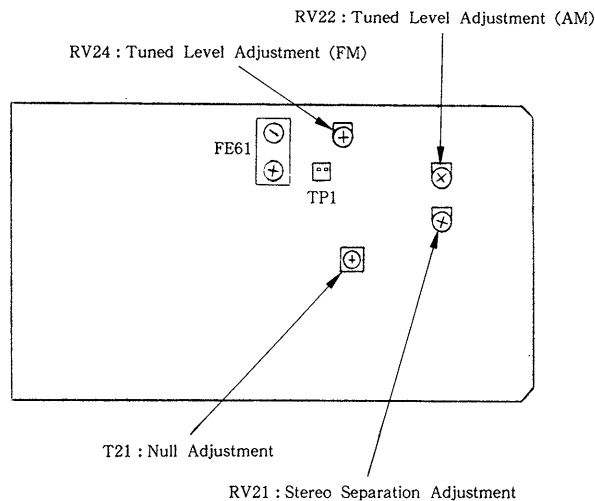

SECTION 3  
DIAGRAMS

3-1. BLOCK DIAGRAMS

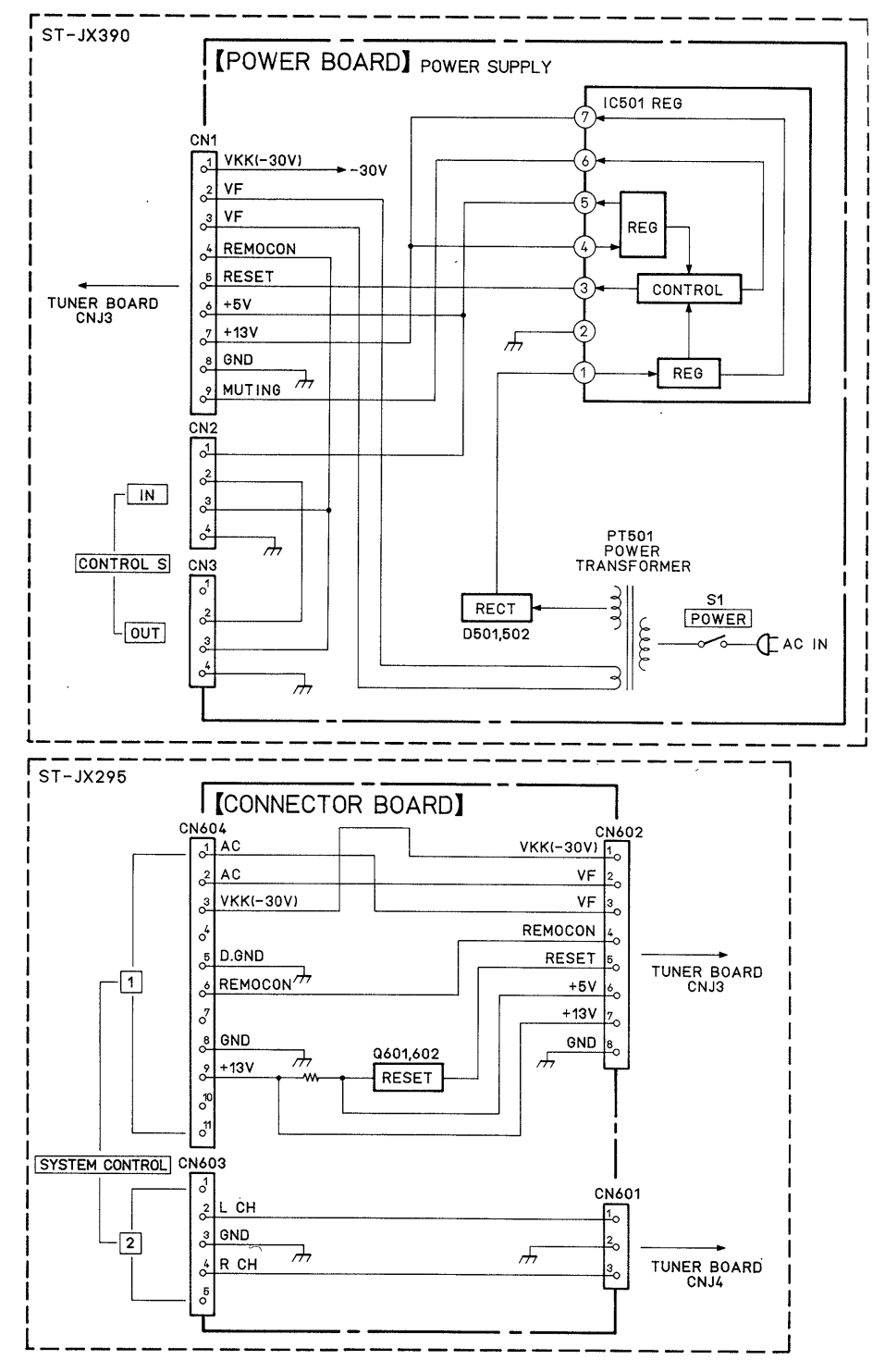
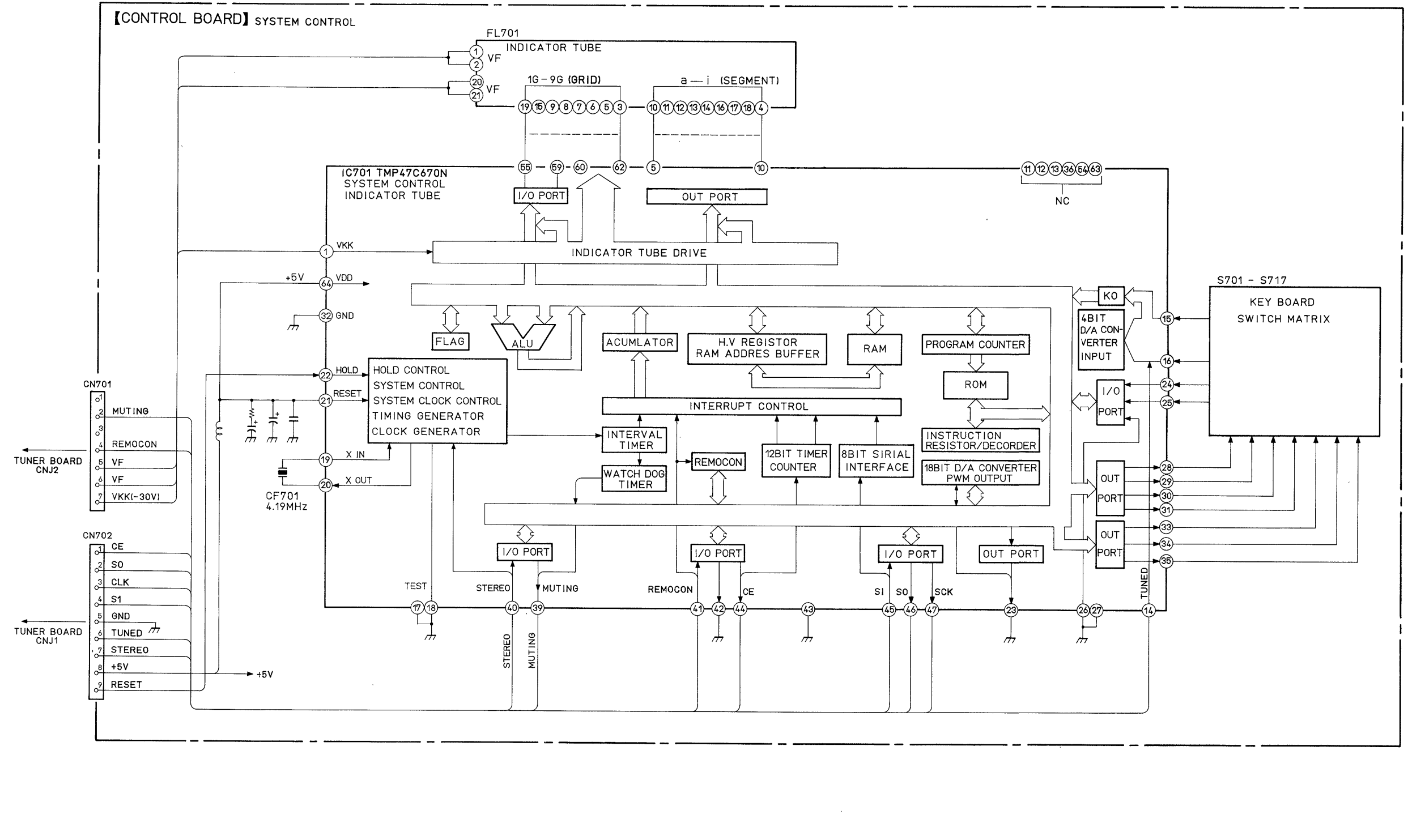
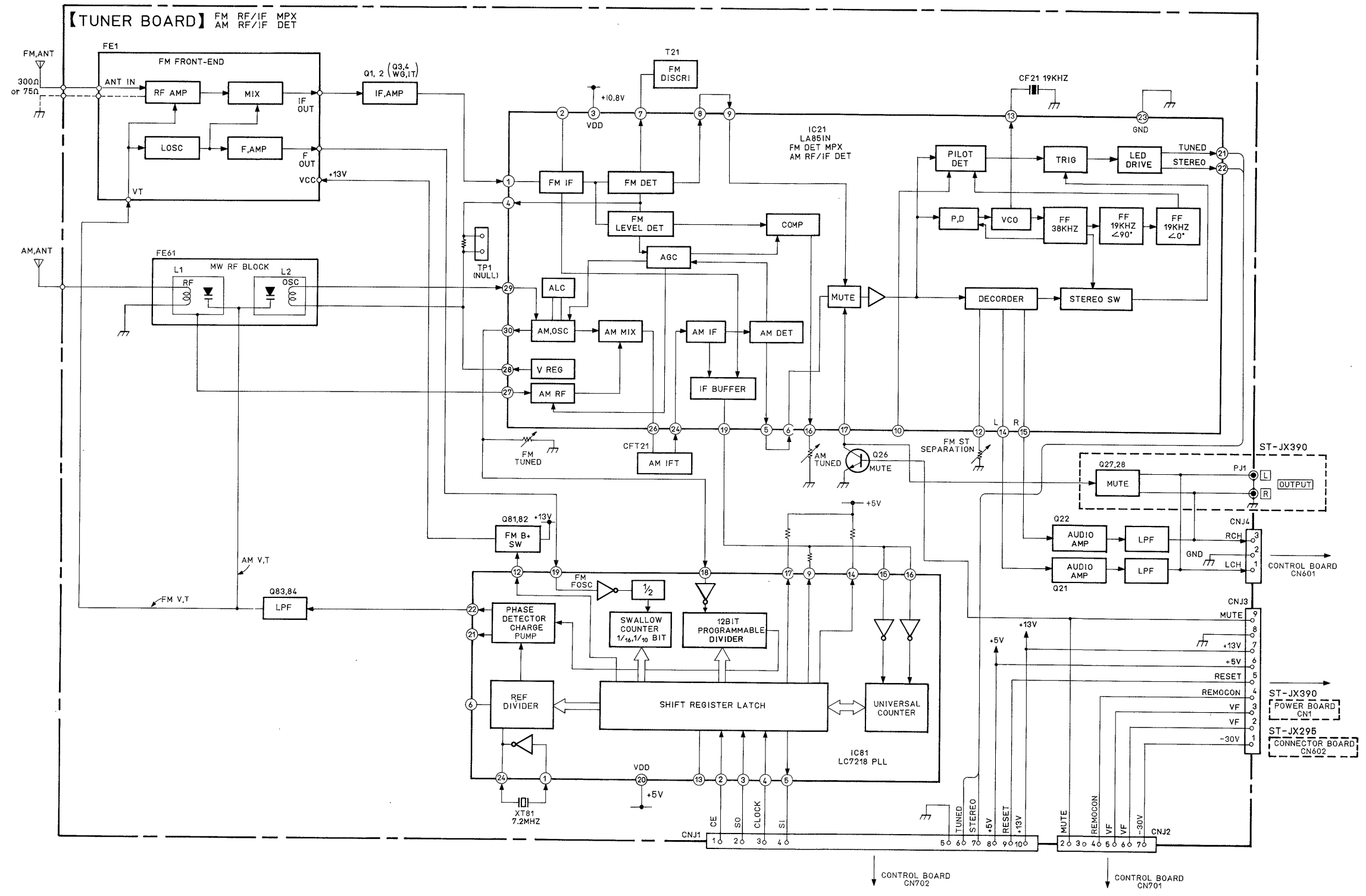

3-2. PRINTED WIRING BOARDS

Note :

- Color code or sleeving over the end of the jacket.

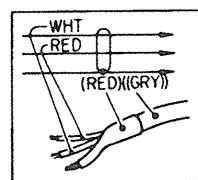

- : parts extracted from the component side.
- : indicates side identified with part number.

[Note on Inserting the Cord to the Connector on Tuner Board]

- Insert the cord to the connector fitting Pin ① of the cord in accordance with the white mark on the board at the connector as shown in the figure.

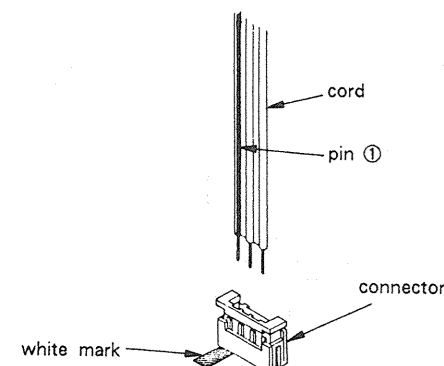

• Semiconductor Location

Ref. No.	Location
D21	H-8
D22	I-8
D23	I-8
D24	H-9
D501	D-19
D502	D-19
D503	D-19
D504	D-19
D505	E-18
D506	E-19
D507	B-16
D801	H-12
D802	H-11
D803	H-13
D701	C-13
D702	C-9
D703	C-7
D707	C-2
D708	B-2
D709	B-2
D710	B-8
D711	B-7
D712	B-6
D713	B-5
D714	B-4
D715	B-3
D716	C-3
D717	C-3
D718	C-2
IC21	H-7
IC81	F-4
IC501	B-19
IC701	B-11
Q1	G-4
Q2	G-5
Q22	G-8
Q21	G-8
Q26	I-8
Q27	G-8
Q28	H-8
Q81	G-6
Q82	G-6
Q83	F-3
Q84	F-3
Q601	H-11
Q602	H-12

• Semiconductor Lead Layouts

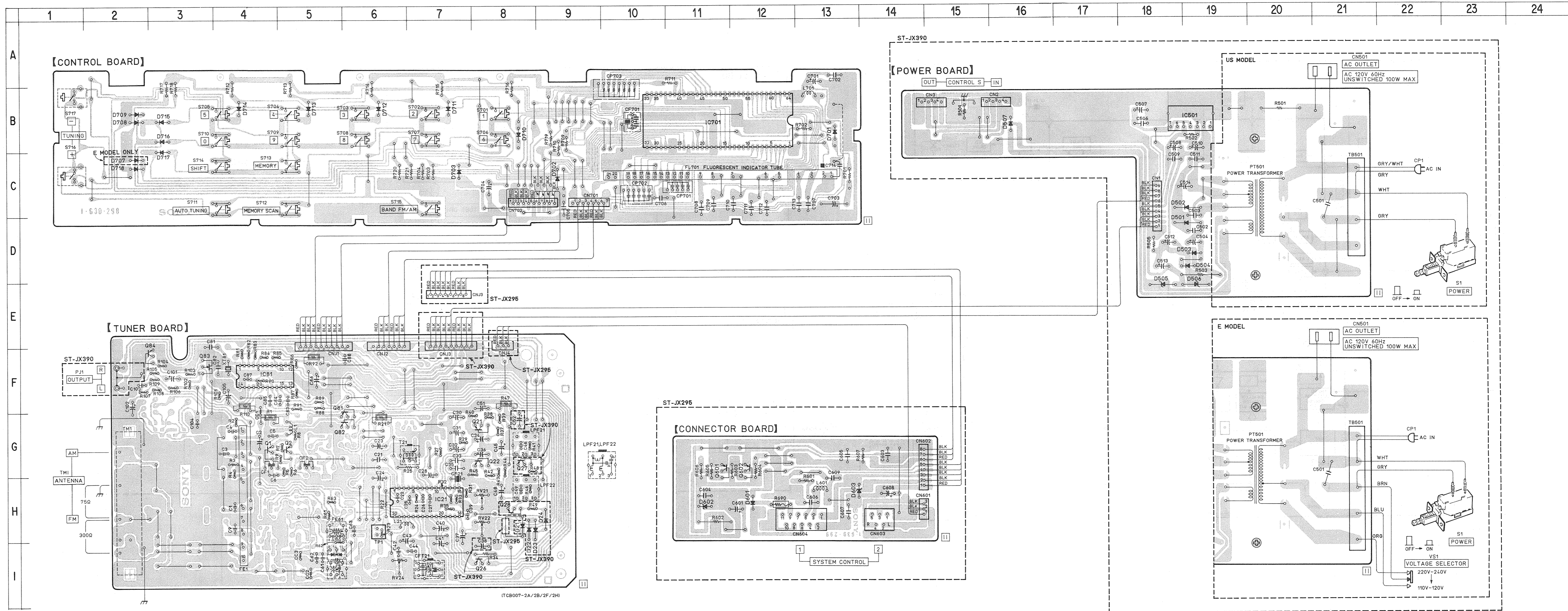
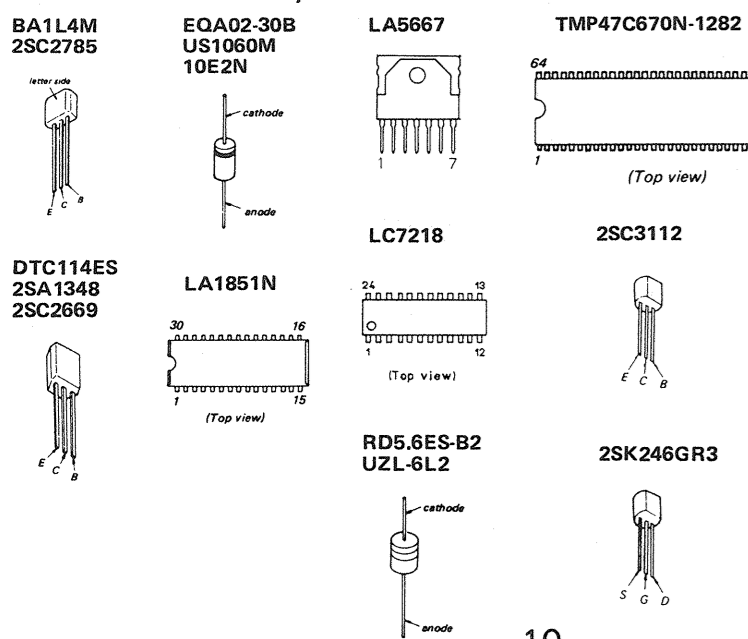

3-3. SCHEMATIC DIAGRAM — Tuner Section —

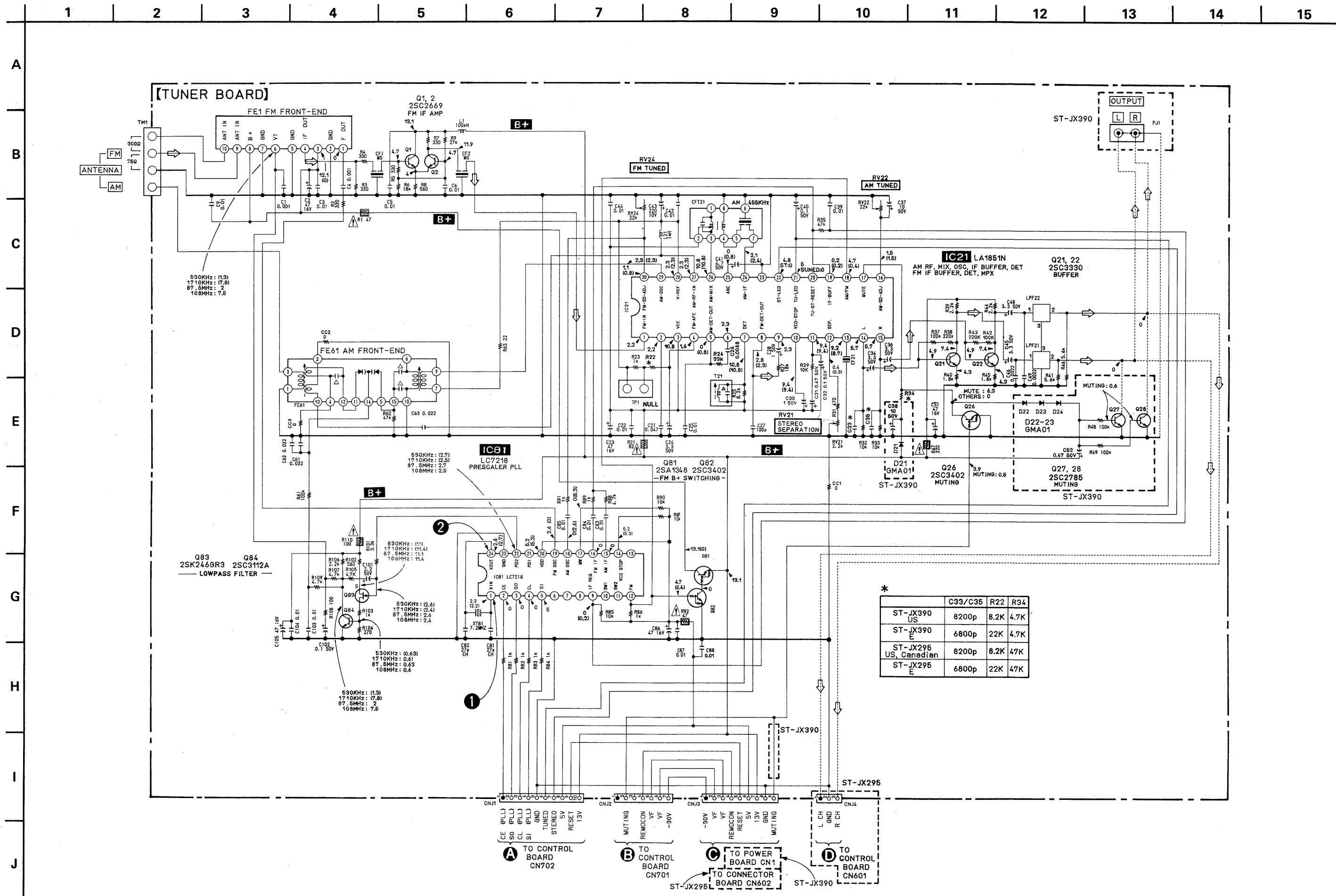

● FE1(Front End) Schematic Diagram

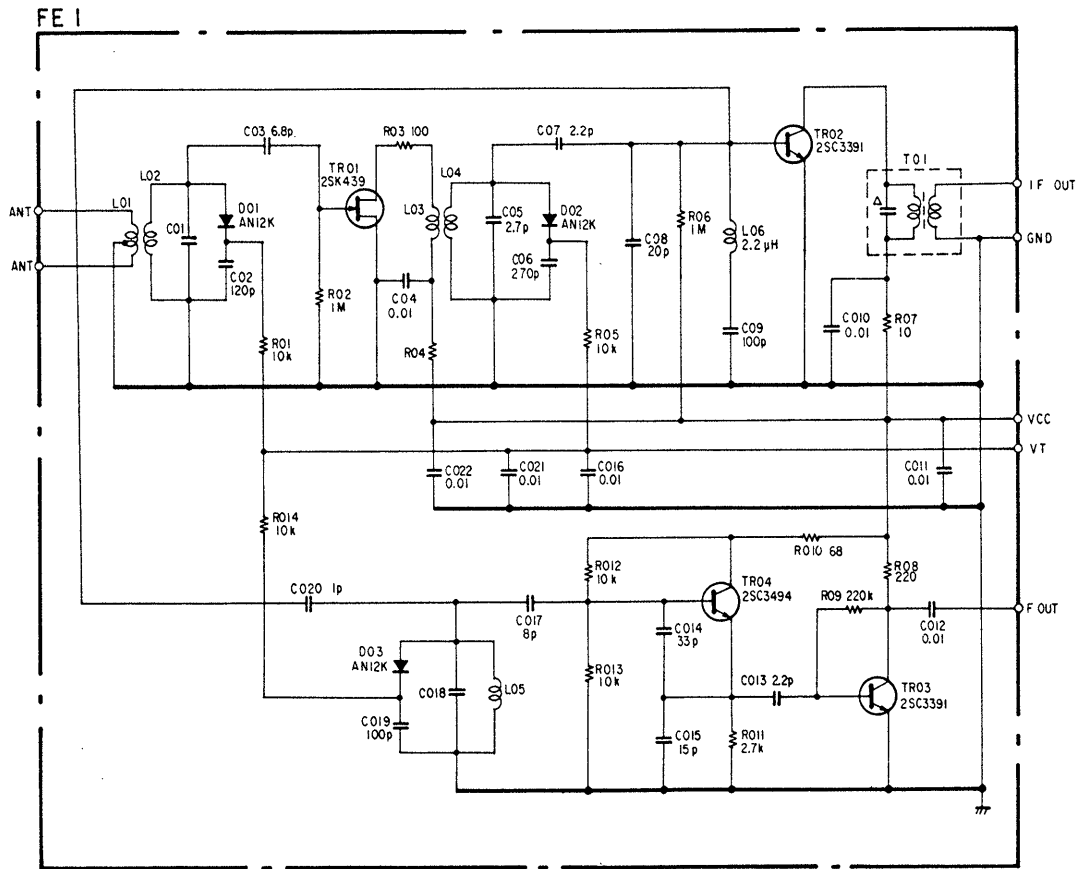

● Wave Forms

No.	Wave Forms	No.	Wave Forms
①		③	
②		④	
		⑤	



3-4. SCHEMATIC DIAGRAM — Control and Power Section —

1 2 3 4 5 6 7 8 9 10 11 12 13 14 15 16 17 18 19

- Note :**
- All capacitors are in  $\mu\text{F}$  unless otherwise noted.
  - pF :  $\mu\text{F}$  50 WV or less are not indicated except for electrolytics and tantalums.
  - All resistors are in  $\Omega$  and  $\frac{1}{4}$  W or less unless otherwise specified.
  - $\Delta$  : internal component.
  - : nonflammable resistor.
  - : fusible resistor.

**Note :**  
The components identified by mark  $\Delta$  or dotted line with mark  $\Delta$  are critical for safety. Replace only with part number specified.

**Note :**  
Les composants identifiés par une marque  $\Delta$  sont critiques pour la sécurité. Ne les remplacer que par une pièce portant le numéro spécifié.

- B+** : B+ Line.
- B-** : B- Line.
- : adjustment for repair.
- Voltage and waveforms are dc with respect to ground under no-signal (detuned) conditions.
- no mark : FM
- ( ) : AM
- Voltage are taken with a VOM (Input impedance 10 M $\Omega$ ). Voltage variations may be noted due to normal production tolerances.
- Waveforms are taken with an oscilloscope. Voltage variations may be noted due to normal production tolerances.
- Circled numbers refer to waveforms.
- Signal path.
- : FM

**[Service Note]**

INDICATOR TUBE ALL LIGHT-UP MODE  
When turning POWER switch on while pressing PRESET 1 and AUTO TUNING KEYS simultaneously, all the segments of FL701 will light.

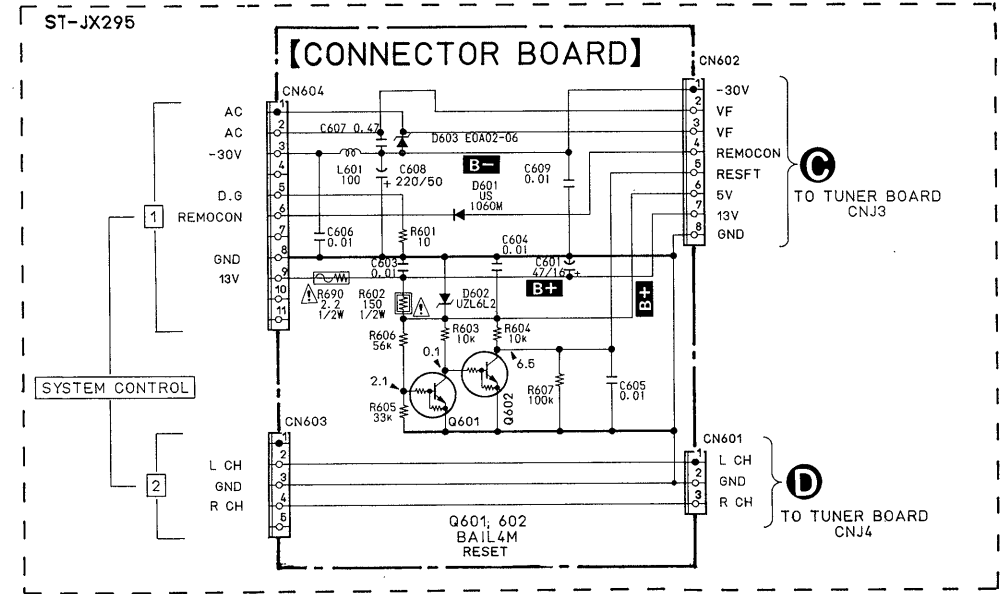
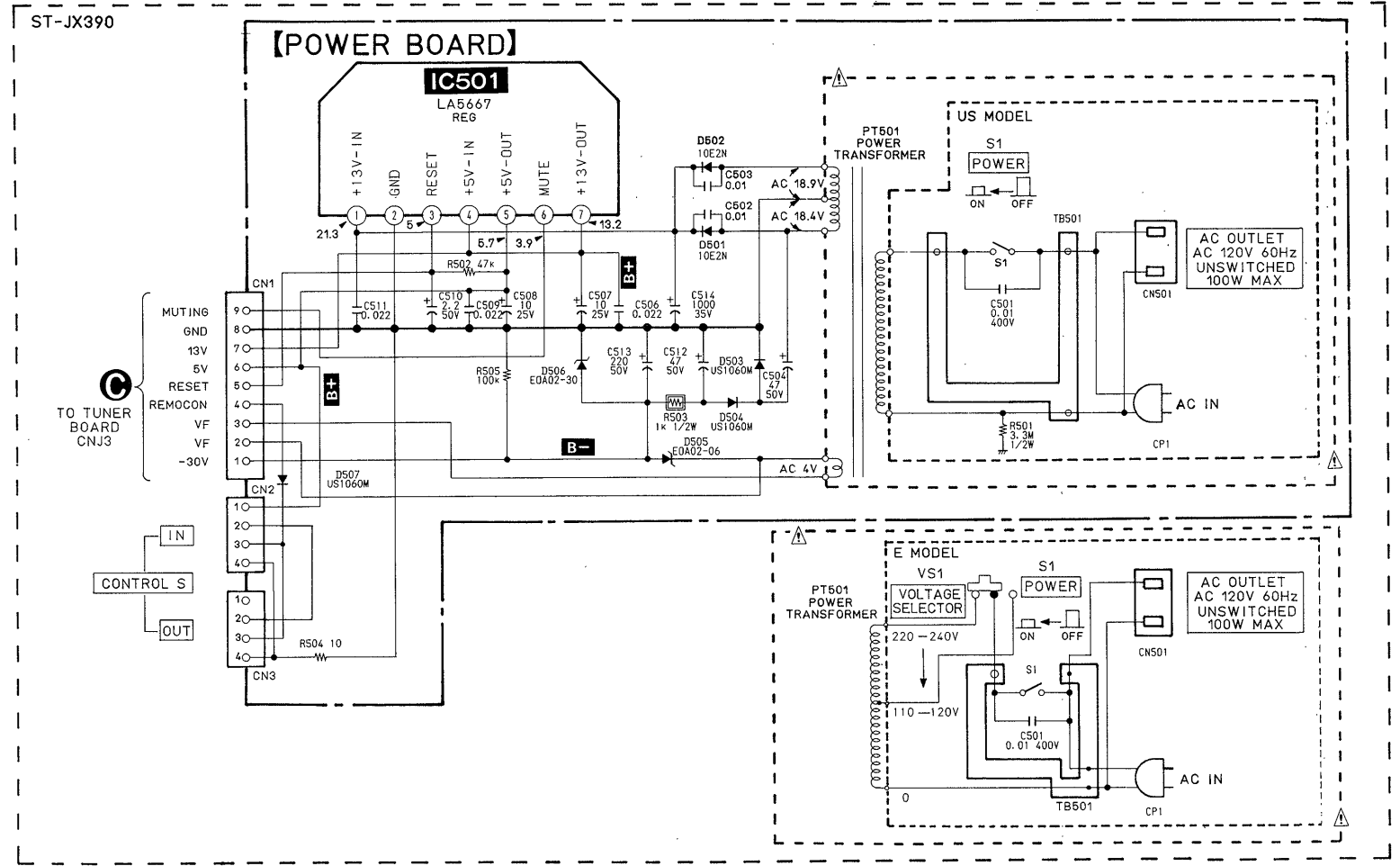
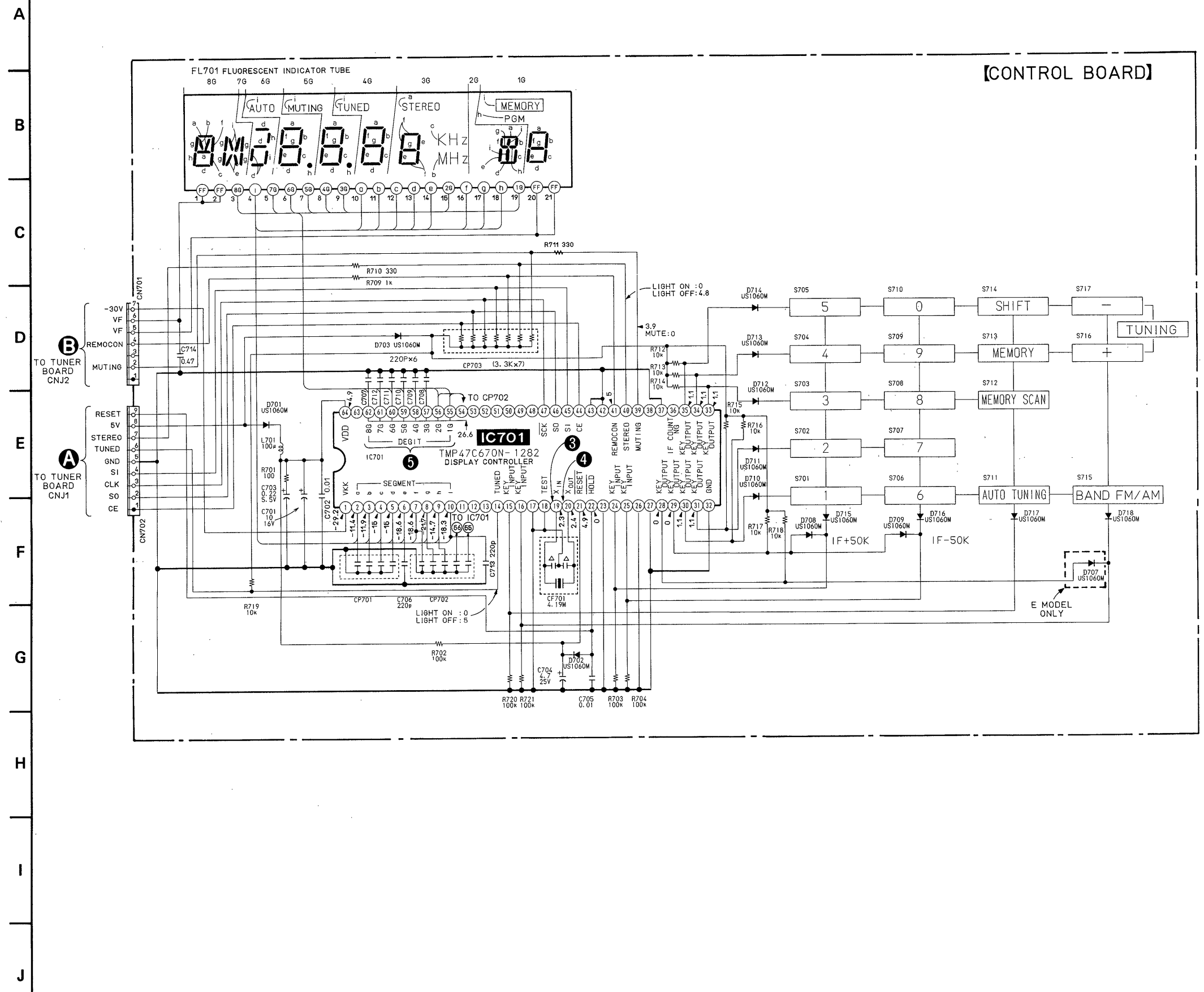

**SECTION 4  
EXPLODED VIEW**

**NOTE:**

- The mechanical parts with no reference number in the exploded views are not supplied.
- The construction parts of an assembled part are indicated with a collation number in the remark column.
- Items marked "★" are not stocked since they are seldom required for routine service. Some delay should be anticipated when ordering these items.

- Due to standardization, parts with part number suffix -XX and -X may be different from the parts specified in the components used on the set.
- Color Indication of Appearance Parts  
Example:  
(RED) ... KNOB, BALANCE (WHITE)  
↑ Cabinet's Color                      ↑ Parts' Color

The components identified by mark **▲** or dotted line with mark **▲** are critical for safety. Replace only with part number specified.

Les composants identifiés par une marque **▲** sont critiques pour la sécurité. Ne les remplacer que par une pièce portant le numéro spécifié.

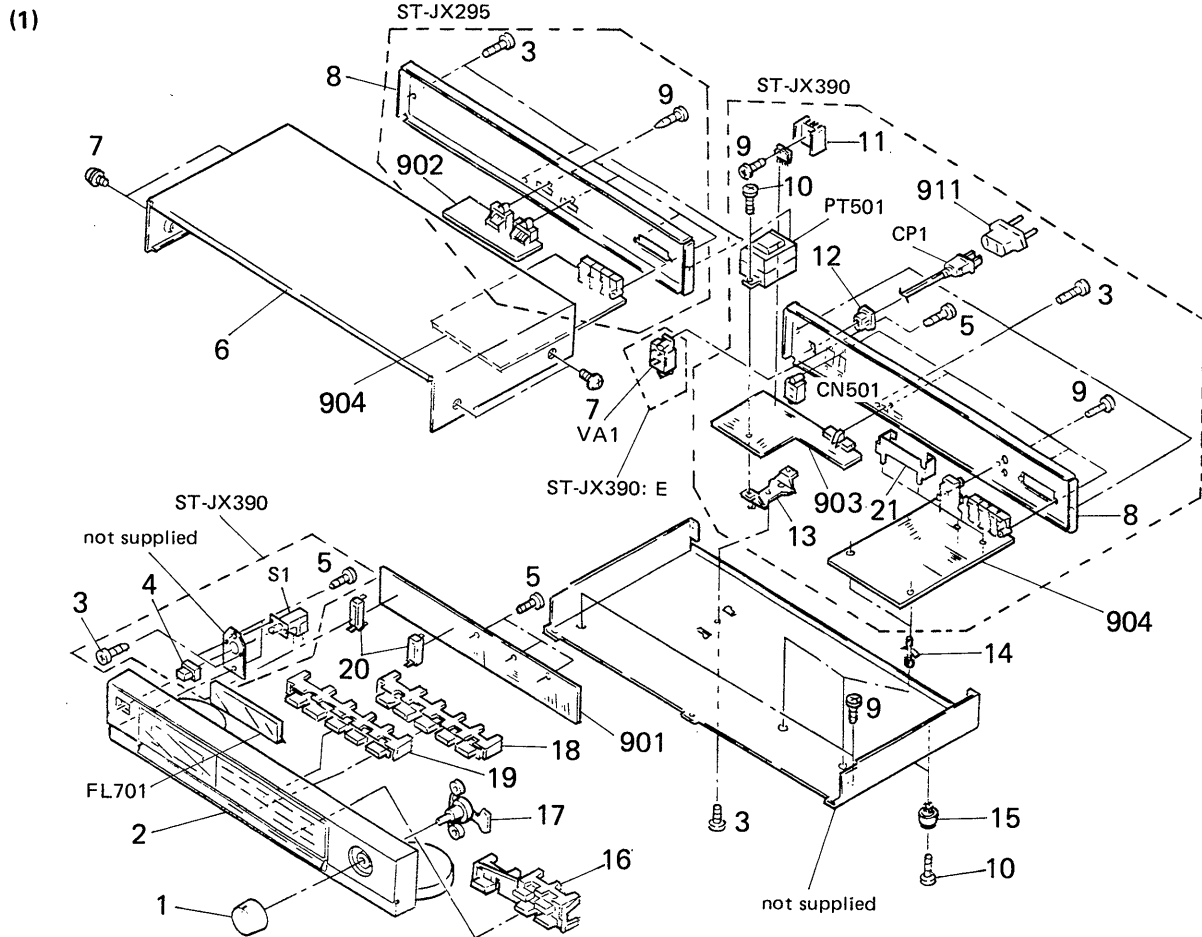

No.	Part No.	Description	Remarks	No.	Part No.	Description	Remarks
1	4-922-790-11	KNOB (TUNING)		21	*4-924-988-11	PLATE (ST), GROUND	
2	X-4905-263-1	(JX295)...PANEL ASSY, FRONT		901	*A-4333-249-A	(JX295:US,Canadian) ...MOUNTED PCB, CONTROL	
	X-4905-264-1	(JX390)...PANEL ASSY, FRONT			*A-4333-250-A	(JX295:E)...MOUNTED PCB, CONTROL	
3	7-682-548-04	SCREW +BVT 3X8 (S)			*A-4333-480-A	(JX390:E)...MOUNTED PCB, CONTROL	
4	4-917-460-01	(JX390)...KNOB, POWER			*A-4333-481-A	(JX390:US)...MOUNTED PCB, CONTROL	
5	7-685-534-19	SCREW +BTP 2.6X8 TYPE2 N-S		902	*1-630-299-11	(JX295)...PC BOARD, CONNECTOR	
6	4-917-050-41	CASE		903	*1-630-297-11	(JX390)...PC BOARD, POWER	
7	3-704-366-01	SCREW (CASE) (M3X8)		904	*A-4303-176-A	(JX295:US Canadian)...MOUNTED PCB TUNER	
8	*4-917-058-01	(JX295).....PANEL, BACK			*A-4303-177-A	(JX295:E).....MOUNTED PCB TUNER	
	*4-917-065-01	(JX390:US)...PANEL, BACK			*A-4303-174-A	(JX390:US).....MOUNTED PCB TUNER	
	*4-917-065-11	(JX390:E)...PANEL, BACK			*A-4303-175-A	(JX390:E).....MOUNTED PCB TUNER	
9	7-685-646-79	SCREW +BVT 3X8 TYPE2 N-S		911	▲.1-526-565-12	(JX390:E)...AC PLUG ADAPTOR	
10	7-682-550-04	SCREW +BVT 3X12 (S)		CN501▲.1-540-038-11	(JX390:E)...OUTLET, AC (NONPOLAR)		
11	*4-363-146-31	(JX390)...HEAT SINK, V.OUT		CN501▲.1-540-057-11	(JX390:US)...OUTLET, AC (POLAR)		
12	*3-703-244-00	(JX390:US)...BUSHING (2104), CORD		CP1 ▲.1-551-188-XX	(JX390:E)...CORD, POWER		
	*3-703-571-12	(JX390:E)...BUSHING (4516), CORD		CP1 ▲.1-557-577-11	(JX390:US)...CORD, POWER		
13	*4-917-044-11	(JX390)...BRACKET (PT)		FL701 1-519-512-11	INDICATOR TUBE, FLUORESCENT		
14	*3-346-265-11	HOLDER, PC BOARD		PJ1 1-565-352-21	(JX390)...JACK, PIN 2P		
15	X-4904-496-1	FOOT ASSY		PT501▲.1-449-526-11	(JX390:E)...TRANSFORMER, POWER		
16	4-917-063-01	BUTTON (T)		PT501▲.1-449-527-11	(JX390:US)...TRANSFORMER, POWER		
17	*4-917-061-01	SHAFT, TUN		S1 ▲.1-554-920-11	(JX390)...SWITCH, PUSH (AC POWER)(1 KEY)		
18	4-917-064-11	BUTTON (10 KEY)(6-0)		VSI ▲.1-570-046-21	(JX390:E)...SWITCH, VOLTAGE CHANGE		
19	4-917-064-01	BUTTON (10 KEY)(1-5)					
20	*4-924-989-01	HOLDER (FL TUBE)					

## SECTION 5

### ELECTRICAL PARTS LIST

**NOTE:**

- Due to standardization, replacements in the parts list may be different from the parts specified in the diagrams or the components used on the set.
- Items marked "\*" are not stocked since they are seldom required for routine service. Some delay should be anticipated when ordering these items.
- If there are two or more same circuits in a set such as a stereophonic machine, only typical circuit parts may be indicated and capacitors and resistors in other same circuits may be omitted.

**CAPACITORS:**MF:  $\mu$ F, PF:  $\mu$ F.**RESISTORS**

- All resistors are in ohms.
- F: nonflammable

**COILS**

- MMH: mH, UH:  $\mu$ H

**SEMICONDUCTORS**In each case, U:  $\mu$ , for example:
 UA...:  $\mu$ A..., UPA...:  $\mu$ PA...,  
 UPC...:  $\mu$ PC, UPD...:  $\mu$ PD...

The components identified by mark  $\Delta$  or dotted line with mark  $\Delta$  are critical for safety. Replace only with part number specified.

Les composants identifiés par une marque  $\Delta$  sont critiques pour la sécurité. Ne les remplacer que par une pièce portant le numéro spécifié.

Ref.No.	Part No.	Description	Ref.No.	Part No.	Description
901	*A-4333-249-A	(JX295:US,Canadian) ...MOUNTED PCB, CONTROL	C49	1-162-524-11	CERAMIC CHIP 0.0022MF 20% 25V
	*A-4333-250-A	(JX295:E)...MOUNTED PCB, CONTROL	C51	1-124-477-11	CAP, ELECT 47MF 20% 16V
	*A-4333-480-A	(JX390:US)...MOUNTED PCB, CONTROL	C52	1-124-902-11	(JX390)...CAP,ELECT 0.47MF 20% 50V
	*A-4333-481-A	(JX390:US)...MOUNTED PCB, CONTROL	C61	1-163-063-00	CERAMIC MELF 0.022MF 25V
902	*1-630-299-11	(JX295)...PC BOARD, CONNECTOR	C62	1-163-063-00	CERAMIC MELF 0.022MF 25V
903	*1-630-297-11	(JX390)...PC BOARD, POWER	C63	1-163-063-00	CERAMIC MELF 0.022MF 25V
904	*A-4303-176-A	(JX295:US,Canadian)...MOUNTED PCB TUNER	C64	1-163-063-00	CERAMIC MELF 0.022MF 25V
	*A-4303-177-A	(JX295:E)...MOUNTED PCB TUNER	C81	1-102-961-00	CAP, CERAMIC 27PF 5% 50V
	*A-4303-174-A	(JX390:US)...MOUNTED PCB TUNER	C82	1-102-961-00	CAP, CERAMIC 27PF 5% 50V
	*A-4303-175-A	(JX390:E)...MOUNTED PCB TUNER	C83	1-163-059-00	CERAMIC MELF 0.01MF 20% 16V
911	$\Delta$ 1-526-565-12	(JX390:E)...AC PLUG ADAPTOR	C84	1-163-059-00	CERAMIC MELF 0.01MF 20% 16V
C1	1-162-294-31	CERAMIC CHIP 0.001MF 20% 25V	C85	1-163-059-00	CERAMIC MELF 0.01MF 20% 16V
C2	1-124-477-11	CAP, ELECT 47MF 20% 16V	C86	1-124-477-11	CAP, ELECT 47MF 20% 16V
C3	1-163-059-00	CERAMIC MELF 0.01MF 20% 16V	C87	1-163-059-00	CERAMIC MELF 0.01MF 20% 16V
C4	1-162-294-31	CERAMIC CHIP 0.001MF 20% 25V	C88	1-163-059-00	CERAMIC MELF 0.01MF 20% 16V
C5	1-163-059-00	CERAMIC MELF 0.01MF 20% 16V	C101	1-124-925-11	CAP, ELECT 2.2MF 20% 50V
C6	1-163-059-00	CERAMIC MELF 0.01MF 20% 16V	C102	1-124-463-00	CAP, ELECT 0.1MF 20% 50V
C9	1-163-059-00	CERAMIC MELF 0.01MF 20% 16V	C105	1-124-477-11	CAP, ELECT 47MF 20% 16V
C21	1-161-021-11	CAP, CERAMIC 0.047MF 10% 25V	C103	1-163-059-00	CERAMIC MELF 0.01MF 20% 16V
C22	1-163-059-00	CERAMIC MELF 0.01MF 20% 16V	C104	1-163-059-00	CERAMIC MELF 0.01MF 20% 16V
C23	1-124-477-11	CAP, ELECT 47MF 20% 16V	C501	$\Delta$ 1-161-744-00	CERAMIC 0.01MF 400V
C24	1-123-382-00	CAP, ELECT 3.3MF 20% 50V	C502	1-101-004-00	CERAMIC 0.01MF 50V
C25	1-163-059-00	CERAMIC MELF 0.01MF 20% 16V	C503	1-101-004-00	CERAMIC 0.01MF 50V
C26	1-162-527-11	CERAMIC CHIP 0.0068MF 20% 12V	C504	1-124-910-11	ELECT 47MF 20% 50V
C27	1-162-516-11	CERAMIC CHIP 100PF 10% 50V	C506	1-101-005-00	CERAMIC 0.022MF 50V
C28	1-124-499-11	CAP, ELECT 1.0MF 20% 50V	C507	1-123-356-00	ELECT 10MF 20% 25V
C30	1-124-499-11	CAP, ELECT 1.0MF 20% 50V	C508	1-123-356-00	ELECT 10MF 20% 25V
C31	1-124-902-00	CAP, ELECT 0.47MF 20% 50V	C509	1-101-005-00	CERAMIC 0.022MF 50V
C32	1-124-463-00	CAP, ELECT 0.1MF 20% 50V	C510	1-124-925-11	ELECT 2.2MF 20% 50V
C33	1-130-481-91	(JX390/JX295:E)...CAP,PE TEREPHTHALATE 00068MF 5% 50V	C511	1-101-005-00	CERAMIC 0.022MF 50V
C33	1-130-482-00	(JX390:US/JX295:US,Canadian)... CAP, PE TEREPHTHALATE 0.0082MF 5% 50V	C512	1-124-910-11	ELECT 47MF 20% 50V
C34	1-123-382-00	CAP, ELECT 3.3MF 20% 50V	C513	1-124-911-11	ELECT 220MF 20% 50V
C35	1-130-481-91	(JX390/JX295:E)...CAP,PE TEREPHTHALATE 00068MF 5% 50V	C514	1-126-105-11	ELECT 1000MF 20% 35V
C35	1-130-482-00	(JX390:US/JX295:US,Canadian)... CAP, PE TEREPHTHALATE 0.0082MF 5% 50V	C601	1-123-332-00	(JX295)...ELECT 47MF 20% 16V
C36	1-123-382-00	CAP, ELECT 3.3MF 20% 50V	C603	1-101-004-00	(JX295)...CERAMIC 0.01MF 20% 50V
C37	1-123-875-11	CAP, ELECT 10MF 20% 50V	C604	1-101-004-00	(JX295)...CERAMIC 0.01MF 20% 50V
C38	1-123-875-11	(JX390)...CAP,ELECT 10MF 20% 50V	C605	1-101-004-00	(JX295)...CERAMIC 0.01MF 20% 50V
C39	1-163-059-00	CERAMIC MELF 0.01MF 20% 16V	C606	1-101-004-00	(JX295)...CERAMIC 0.01MF 20% 50V
C40	1-124-463-00	CAP, ELECT 0.1MF 20% 50V	C607	1-136-173-00	(JX295)...FILM 0.47MF 5% 50V
C41	1-124-927-11	CAP, ELECT 4.7MF 20% 50V	C608	1-124-122-11	(JX295)...ELECT 100MF 20% 50V
C42	1-163-059-00	CERAMIC MELF 0.01MF 20% 16V	C609	1-101-004-00	(JX295)...CERAMIC 0.01MF 20% 50V
C43	1-126-176-11	CAP, ELECT 220MF 20% 10V	C701	1-126-157-11	ELECT 10MF 20% 16V
C44	1-163-059-00	CERAMIC MELF 0.01MF 20% 16V	C702	1-161-379-00	CERAMIC 0.01MF 30% 16V
C45	1-123-382-00	CAP, ELECT 3.3MF 20% 50V	C703	1-125-486-11	CAP,DOUBLELAYEKS 0.22F 5.5V
C46	1-162-524-11	CERAMIC CHIP 0.0022MF 20% 25V	C704	1-126-094-11	ELECT 4.7MF 20% 25V
C48	1-123-382-00	CAP, ELECT 3.3MF 20% 50V	C705	1-161-379-00	CERAMIC 0.01MF 30% 16V

Ref.No.	Part No.	Description			
C706	1-162-286-31	CERAMIC	220PF	10%	50V
C707	1-162-286-31	CERAMIC	220PF	10%	50V
C708	1-162-286-31	CERAMIC	220PF	10%	50V
C709	1-162-286-31	CERAMIC	220PF	10%	50V
C710	1-162-286-31	CERAMIC	220PF	10%	50V
C711	1-162-286-31	CERAMIC	220PF	10%	50V
C712	1-162-286-31	CERAMIC	220PF	10%	50V
C713	1-162-286-31	CERAMIC	220PF	10%	50V
C714	1-136-173-00	FILM	0.47MF	5%	50V
CC1	1-249-366-11	CARBON MELF	0	5%	1/5W
CC2	1-249-366-11	CARBON MELF	0	5%	1/5W
CC3	1-249-366-11	CARBON MELF	0	5%	1/5W
CF1	1-567-389-11	FILTER, CERAMIC			
CF2	1-567-389-11	FILTER, CERAMIC			
CF21	1-577-075-11	OSCILLATOR, CERAMIC			
CF701	1-577-359-21	VIBRATOR, CERAMIC			
CFT21	1-404-853-11	TRANSFORMER, IF (CERAMIC FILTER)			
CN1	*1-568-284-11	SOCKET, CONNECTOR 9P			
CN2	1-564-980-11	(JX390)...PIN, CONNECTOR 4P			
CN3	1-564-980-11	(JX390)...PIN, CONNECTOR 4P			
CN501A	1-540-038-11	(JX390:E)...OUTLET, AC (NONPOLAR)			
CN501A	1-540-057-11	(JX390:US)...OUTLET, AC (POLAR)			
CN601	1-568-278-11	(JX295)...SOCKET, CONNECTOR 3P			
CN602	1-568-283-11	(JX295)...SOCKET, CONNECTOR 8P			
CN603	1-566-856-11	(JX295)...SOCKET, CONNECTOR 5P			
CN604	1-566-858-11	(JX295)...SOCKET, CONNECTOR 11P			
CN701	1-568-282-11	SOCKET, CONNECTOR 7P			
CN702	*1-568-284-11	SOCKET, CONNECTOR 9P			
CNJ1	*1-568-276-11	SOCKET, CONNECTOR 10P			
CNJ2	*1-568-273-11	SOCKET, CONNECTOR 7P			
CNJ3	*1-568-275-11	SOCKET, CONNECTOR 9P			
CNJ4	1-568-269-11	(JX295)...SOCKET, CONNECTOR 3P			
CP1	A.1-551-188-XX	(JX390:E)...CORD, POWER			
CP1	A.1-557-577-11	(JX390).....CORD, POWER			
CP701	1-233-148-11	COMPOSITION CIRCUIT BLOCK			
D21	8-719-000-26	(JX390)...DIODE US1060M			
D22	8-719-000-26	(JX390)...DIODE US1060M			
D23	8-719-000-26	(JX390)...DIODE US1060M			
D24	8-719-000-26	(JX390)...DIODE US1060M			
D501	8-719-200-77	DIODE 10E2N			
D502	8-719-200-77	DIODE 10E2N			
D503	8-719-000-26	DIODE US1060M			
D504	8-719-000-26	DIODE US1060M			
D505	8-719-109-89	DIODE RD5.6ES-B2			
D506	8-719-904-93	DIODE EQA02-30B			
D507	8-719-000-26	DIODE US1060M			
D601	8-719-000-26	(JX295)...DIODE US1060M			
D602	8-719-000-51	(JX295)...DIODE UZL-6L2			
D603	8-719-109-89	(JX295)...DIODE RD5.6ES-B2			
D701	8-719-000-26	DIODE US1060M			
D702	8-719-000-26	DIODE US1060M			
D703	8-719-000-26	DIODE US1060M			
D707	8-719-000-26	(JX390/JX295:E)...DIODE US1060M			
D708	8-719-000-26	DIODE US1060M			
D709	8-719-000-26	DIODE US1060M			
D710	8-719-000-26	DIODE US1060M			
D711	8-719-000-26	DIODE US1060M			
D712	8-719-000-26	DIODE US1060M			

Ref.No.	Part No.	Description			
D713	8-719-000-26	DIODE US1060M			
D714	8-719-000-26	DIODE US1060M			
D715	8-719-000-26	DIODE US1060M			
D716	8-719-000-26	DIODE US1060M			
D717	8-719-000-26	DIODE US1060M			
D718	8-719-000-26	DIODE US1060M			
FE1	1-463-862-21	FRONT END, FM			
FE61	1-236-461-11	ENCAPSULATED COMPONENT			
FL701	1-519-512-11	INDICATOR TUBE, FLUORESCENT			
IC21	8-759-821-45	IC LA1851N			
IC81	8-759-820-91	IC LC7218			
IC501	8-759-820-09	IC LA5667			
IC701	8-759-234-26	IC TMP47C670N-1282			
L1	1-410-521-11	MICRO INDUCTOR			
L21	1-410-171-11	MICRO INDUCTOR			
L601	1-410-521-11	(JX295)...INDUCTOR 100UH			
L701	1-410-521-11	INDUCTOR 100UH			
LPF21	1-235-164-00	FILTER, LOW PASS			
LPF22	1-235-164-00	FILTER, LOW PASS			
PJ1	1-565-352-21	(JX390)...JACK, PIN 2P			
PT501A	1-449-526-11	(JX390:E)...TRANSFORMER, POWER			
PT501A	1-449-527-11	(JX390:US)...TRANSFORMER, POWER			
Q1	8-729-266-93	TRANSISTOR 2SC2669			
Q2	8-729-266-93	TRANSISTOR 2SC2669			
Q21	8-729-119-78	TRANSISTOR 2SC2785			
Q22	8-729-119-78	TRANSISTOR 2SC2785			
Q26	8-729-900-80	TRANSISTOR DT C114ES			
Q27	8-729-119-78	(JX390)...TRANSISTOR 2SC2785			
Q28	8-729-119-78	(JX390)...TRANSISTOR 2SC2785			
Q81	8-729-806-10	TRANSISTOR 2SA1348			
Q82	8-729-900-80	TRANSISTOR DT C114ES			
Q83	8-729-202-67	TRANSISTOR 2SK246GR3			
Q84	8-729-201-84	TRANSISTOR 2SC3112-13			
Q601	8-729-115-77	(JX295)...TRANSISTOR BAIL4M			
Q602	8-729-115-77	(JX295)...TRANSISTOR BAIL4M			
R1	A.1-249-401-11	RES, CARBON (SMALL) 47	5%	1/4W	F
R2	1-249-329-11	CARBON MELF 330	5%	1/8W	
R3	1-249-329-11	CARBON MELF 330	5%	1/8W	
R4	1-249-329-11	CARBON MELF 330	5%	1/8W	
R5	1-249-329-11	CARBON MELF 330	5%	1/8W	
R6	1-249-350-11	CARBON MELF 18K	5%	1/8W	
R7	1-249-329-11	CARBON MELF 330	5%	1/8W	
R8	1-249-332-11	CARBON MELF 560	5%	1/8W	
R9	1-249-352-11	CARBON MELF 27K	5%	1/8W	
R21	A.1-249-404-00	RES, CARBON (SMALL) 82	5%	1/4W	F
R22	1-249-428-11	(JX390:US/JX295:US, Canadian) ...RES, CARBON (SMALL) 8.2K	5%	1/4W	
R22	1-249-433-00	(JX390/JX295:E) ...RES, CARBON (SMALL) 22K	5%	1/4W	
R23	1-249-335-11	CARBON MELF 1K	5%	1/8W	
R24	1-249-353-11	CARBON MELF 33K	5%	1/8W	
R25	1-249-428-11	RES, CARBON (SMALL) 8.2K	5%	1/4W	
R27	1-249-350-11	CARBON MELF 18K	5%	1/8W	
R29	1-249-347-11	CARBON MELF 10K	5%	1/8W	
R31	1-249-331-11	CARBON MELF 470	5%	1/8W	
R32	1-249-347-11	CARBON MELF 10K	5%	1/8W	
R33	1-249-347-11	CARBON MELF 10K	5%	1/8W	

**Note:**

The components identified by mark  $\Delta$  or dotted line with mark  $\Delta$  are critical for safety. Replace only with part number specified.

**Note:**

Les composants identifiés par une marque  $\Delta$  sont critiques pour la sécurité. Ne les remplacer que par une pièce portant le numéro spécifié.

Ref.No.	Part No.	Description	Ref.No.	Part No.	Description
R34	1-249-425-11	(JX390)...RES,CARBON(SMALL) 4.7K	R690	△,1-212-942-00	(JX295)...FUSIBLE 2.2 5% 1/2W
R34	1-249-437-11	(JX295)...RES,CARBON(SMALL) 47K 5% 1/4W	R701	1-249-405-11	CARBON 100 5% 1/4W
R35	1-249-355-11	CARBON MELF 47K 5% 1/8W	R702	1-249-441-11	CARBON 100K 5% 1/4W
R37	1-249-359-11	CARBON MELF 100K 5% 1/8W	R703	1-249-441-11	CARBON 100K 5% 1/4W
R38	1-249-363-11	CARBON MELF 220K 5% 1/8W	R704	1-249-441-11	CARBON 100K 5% 1/4W
R39	1-249-339-11	CARBON MELF 2.2K 5% 1/8W	R709	1-249-417-11	CARBON 1K 5% 1/4W
R40	1-249-338-11	CARBON MELF 1.8K 5% 1/8W	R710	1-249-411-11	CARBON 330 5% 1/4W
R41	1-249-344-11	CARBON MELF 5.6K 5% 1/8W	R711	1-249-411-11	CARBON 330 5% 1/4W
R42	1-249-359-11	CARBON MELF 100K 5% 1/8W	R712	1-249-429-11	CARBON 10K 5% 1/4W
R43	1-249-363-11	CARBON MELF 220K 5% 1/8W	R713	1-249-429-11	CARBON 10K 5% 1/4W
R44	1-249-339-11	CARBON MELF 2.2K 5% 1/8W	R714	1-249-429-11	CARBON 10K 5% 1/4W
R45	1-249-338-11	CARBON MELF 1.8K 5% 1/8W	R715	1-249-429-11	CARBON 10K 5% 1/4W
R46	1-249-344-11	CARBON MELF 5.6K 5% 1/8W	R716	1-249-429-11	CARBON 10K 5% 1/4W
R47	△,1-249-409-11	RES, CARBON (SMALL) 220 5% 1/4W F	R717	1-249-429-11	CARBON 10K 5% 1/4W
R48	1-249-359-11	(JX390)...CARBON MELF 100K 5% 1/8W	R718	1-249-429-11	CARBON 10K 5% 1/4W
R49	1-249-359-11	(JX390)...CARBON MELF 100K 5% 1/8W	R719	1-249-429-11	CARBON 10K 5% 1/4W
R61	1-249-359-11	CARBON MELF 100K 5% 1/8W	R720	1-249-441-11	CARBON 100K 5% 1/4W
R62	1-249-355-11	CARBON MELF 47K 5% 1/8W	R721	1-249-441-11	CARBON 100K 5% 1/4W
R63	1-249-315-11	CARBON MELF 22 5% 1/8W	RV21	1-238-013-11	RES, ADJ, CARBON 2.2K
R81	1-249-335-11	CARBON MELF 1K 5% 1/8W	RV22	1-238-017-11	RES, ADJ, CARBON 22K
R82	1-249-335-11	CARBON MELF 1K 5% 1/8W	RV24	1-238-017-11	RES, ADJ, CARBON 22K
R83	1-249-335-11	CARBON MELF 1K 5% 1/8W	S1	△,1-554-920-11	(JX390)..SWITCH, PUSH (AC POWER)(1 KEY)
R84	1-249-335-11	CARBON MELF 1K 5% 1/8W	S701	1-554-303-21	SWITCH, KEY BOARD (1)
R85	1-249-347-11	CARBON MELF 10K 5% 1/8W	S702	1-554-303-21	SWITCH, KEY BOARD (2)
R86	1-249-335-11	CARBON MELF 1K 5% 1/8W	S703	1-554-303-21	SWITCH, KEY BOARD (3)
R87	1-249-347-11	CARBON MELF 10K 5% 1/8W	S704	1-554-303-21	SWITCH, KEY BOARD (4)
R88	1-249-343-11	CARBON MELF 4.7K 5% 1/8W	S705	1-554-303-21	SWITCH, KEY BOARD (5)
R89	1-249-335-11	CARBON MELF 1K 5% 1/8W	S706	1-554-303-21	SWITCH, KEY BOARD (6)
R90	1-249-347-11	CARBON MELF 10K 5% 1/8W	S707	1-554-303-21	SWITCH, KEY BOARD (7)
R91	1-249-335-11	CARBON MELF 1K 5% 1/8W	S708	1-554-303-21	SWITCH, KEY BOARD (8)
R92	△,1-249-401-11	RES, CARBON (SMALL) 47 5% 1/4W F	S709	1-554-303-21	SWITCH, KEY BOARD (9)
R101	1-249-341-11	CARBON MELF 3.3K 5% 1/8W	S710	1-554-303-21	SWITCH, KEY BOARD (0)
R102	1-249-332-11	CARBON MELF 560 5% 1/8W	S711	1-554-303-21	SWITCH, KEY BOARD (AUTO TUNING)
R103	1-249-335-11	CARBON MELF 1K 5% 1/8W	S712	1-554-303-21	SWITCH, KEY BOARD (MEMORY SCAN)
R104	1-249-328-11	CARBON MELF 270 5% 1/8W	S713	1-554-303-21	SWITCH, KEY BOARD (MEMORY)
R105	1-249-343-11	CARBON MELF 4.7K 5% 1/8W	S714	1-554-303-21	SWITCH, KEY BOARD (SHIFT)
R106	1-249-339-11	CARBON MELF 2.2K 5% 1/8W	S715	1-554-303-21	SWITCH, KEY BOARD (BAND FM/AM)
R107	1-249-343-11	CARBON MELF 4.7K 5% 1/8W	S716	1-554-088-00	SWITCH, KEY BOARD (TUNING +)
R108	1-249-323-11	CARBON MELF 100 5% 1/8W	S717	1-554-088-00	SWITCH, KEY BOARD (TUNING -)
R109	1-249-343-11	CARBON MELF 4.7K 5% 1/8W	T21	1-404-807-11	TRANSFORMER, DISCRIMINATOR
R110	△,1-249-405-11	RES, CARBON (SMALL) 100 5% 1/4W F	TB501	*1-535-141-00	(JX390:US)..BASE POST 22MM(10MM PITCH)4P
R501	1-202-725-00	SOLID 3.3M 10% 1/2W	TB501	*1-535-142-21	(JX390:E)...BASE POST 22MM(10MM PITCH)5P
R502	1-249-437-11	CARBON 47K 5% 1/4W	TMI	1-536-708-00	TERMINAL BOARD, PUSH 4P
R503	△,1-247-752-11	CARBON 1K 5% 1/2W F	TP1	*1-560-060-00	PIN, CONNECTOR 2P
R504	1-249-393-11	CARBON 10 5% 1/4W	VSI	△,1-570-046-21	(JX390:E)...SWITCH, VOLTAGE CHANGE
R505	1-249-441-11	CARBON 100K 5% 1/4W	XT81	1-577-126-11	VIBRATOR, CRYSTAL
R601	1-249-393-11	(JX295)...CARBON 10 5% 1/4W			
R602	△,1-247-741-11	(JX295)...CARBON 150 5% 1/2W			
R603	1-249-429-11	(JX295)...CARBON 10K 5% 1/4W			
R604	1-249-429-11	(JX295)...CARBON 10K 5% 1/4W			
R605	1-249-435-11	(JX295)...CARBON 33K 5% 1/4W			
R606	1-249-438-11	(JX295)...CARBON 56K 5% 1/4W			
R607	1-249-441-11	(JX295)...CARBON 100K 5% 1/4W			

**Note:**

The components identified by mark △ or dotted line with mark △ are critical for safety. Replace only with part number specified.

**Note:**

Les composants identifiés par une marque △ sont critiques pour la sécurité. Ne les remplacer que par une pièce portant le numéro spécifié.

ACCESSORY & PACKING MATERIAL

1-501-374-11 (JX390)...ANTENNA, LOOP  
1-558-232-11 (JX390)...CORD (WITH CONNECTOR)(SIRCS)4P  
1-558-543-11 (JX390)...CORD, CONNECTION  
  
3-750-169-11 (JX390:E)...MANUAL, INSTRUCTION  
3-750-169-21 (JX390:US)...MANUAL, INSTRUCTION  
  
\*3-704-339-01 (JX390)...SHEET (STANDARD), PROTECTION  
\*4-917-057-01 (JX390)...CUSHION  
\*4-917-066-01 (JX390)...INDIVIDUAL CARTON .



# ST-JX295/JX390

## SONY SERVICE MANUAL

US Model  
E Model  
ST-JX295/JX390

Canadian Model  
ST-JX295

## SUPPLEMENT-1

File this supplement with the Service Manual.

**Subject :** Australian model has been added.

ST-JX390 Australian model has been added for E model.

This supplement only contains the difference between the models.

Therefore, refer to the service manual for the other information.

ST-JX390 E model				ST-JX390 Australian model	
Page	No.	Part No.	Description	Part No.	Description
	12	*3-703-571-12	BUSHING (4516), CORD	*3-703-244-00	BUSHING (2104), CORD
21	911	△1-526-565-12	AC PLUG ADAPTOR	△1-506-401-00	ADAPTOR, CONVERSION
	CP1	△1-551-188-XX	CORD, POWER	△1-555-795-00	CORD, POWER,EURO PLUG

- Items marked "\*" are not stocked since they are seldom required for routine service. Some delay should be anticipated when ordering these items.



# ST-JX295/JX390

## SONY<sup>®</sup> SERVICE MANUAL

*US Model*

*E Model*

*ST-JX295/JX390*

*Canadian Model*

*ST-JX295*

## SUPPLEMENT-2

**Subject:**  
**TUNER BOARD MODIFICATION**

The tuner board has been modified.  
File this supplement with the service manual.

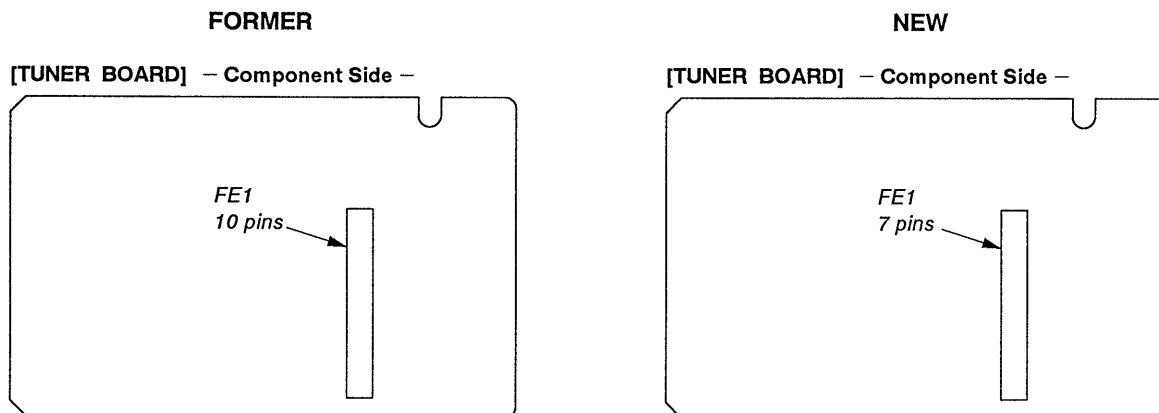

### • DIFFERENCE BETWEEN NEW TYPE AND FORMER TYPE



**Note:** The mounted tuner board can be replaced with the new type as a whole block.



**Note on Printed Wiring Board:**

-  : parts extracted from the component side.
-  : indicates side identified with part number.

**[Note on Inserting the Cord to the Connector on Tuner Board]**

- Insert the cord to the connector fitting Pin ① of the cord in accordance with the white mark on the board at the connector as shown in the figure.

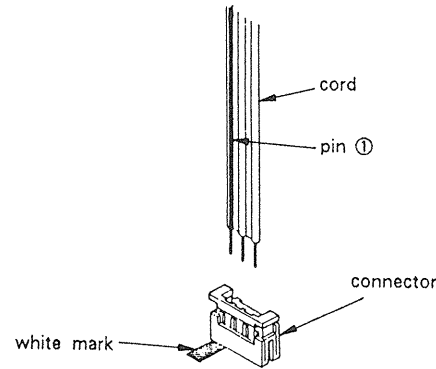

**Note on Schematic Diagram:**

- All capacitors are in  $\mu\text{F}$  unless otherwise noted. pF:  $\mu\text{pF}$ . 50 WV or less are not indicated except for electrolytics and tantalums.
- All resistors are in  $\Omega$  and  $\frac{1}{4}$  W or less unless otherwise specified.
- $\Delta$  : internal component.
-  : nonflammable resistor.

**Note:**  
The components identified by mark  $\Delta$  or dotted line with mark  $\Delta$  are critical for safety. Replace only with part number specified.

**Note:**  
Les composants identifiés par une marque  $\Delta$  sont critiques pour la sécurité. Ne les remplacer que par une pièce portant le numéro spécifié.

- **B+** : B + Line.
- **B-** : B - Line.
-  : adjustment for repair.
- Voltages and waveforms are dc with respect to ground under no-signal (detuned) conditions.  
no mark : FM  
( ) : AM
- Voltages are taken with a VOM (10 M $\Omega/V$ ).  
Voltage variations may be noted due to normal production tolerances.
- Waveforms are taken with an oscilloscope.  
Voltage variations may be noted due to normal production tolerances.
- Circled numbers refer to waveforms.
- Signal path.  
 $\Rightarrow$  : FM

**[PRINTED WIRING BOARD]**

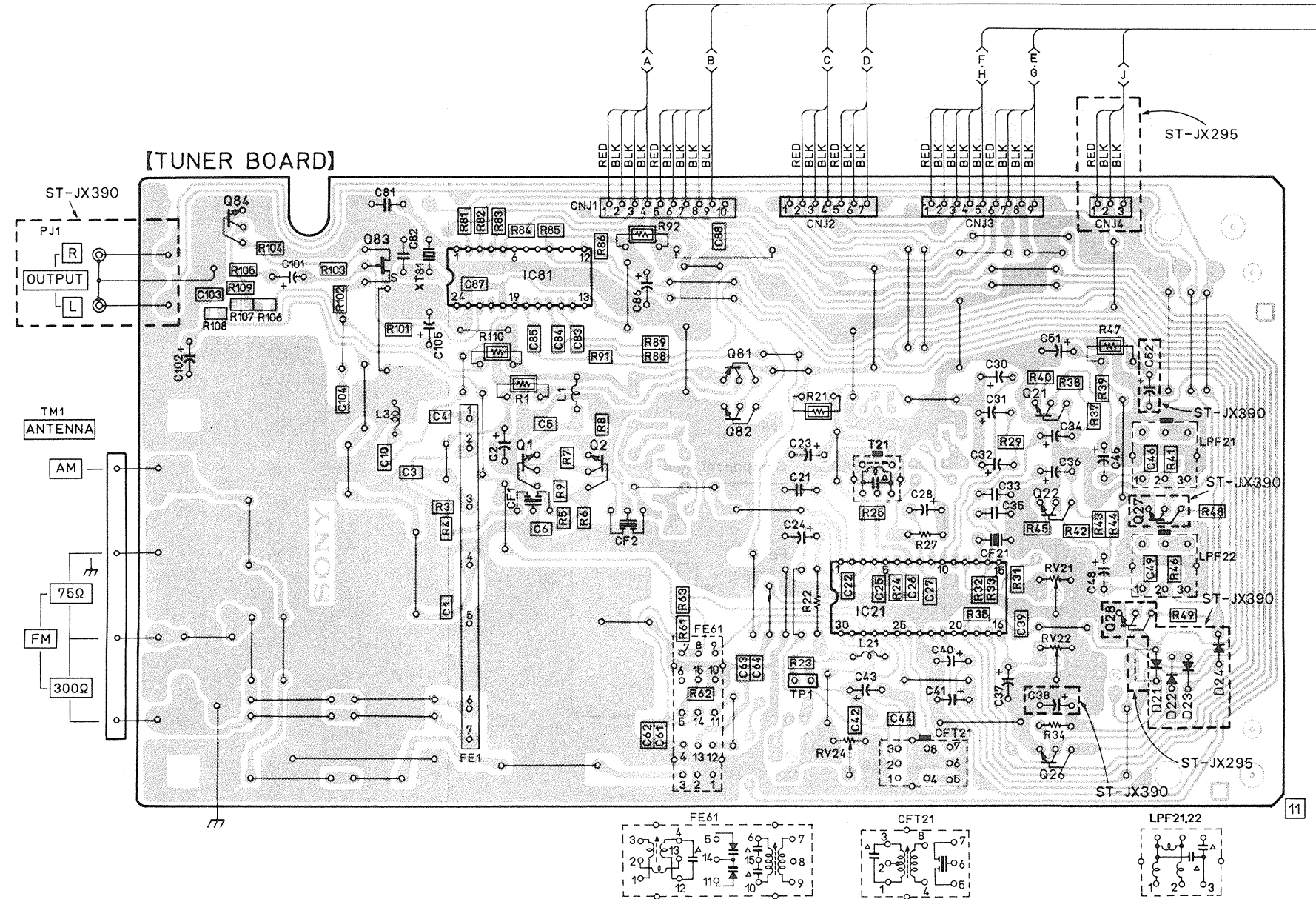

A  
B  
C  
D  
E  
F  
G  
H  
I  
J

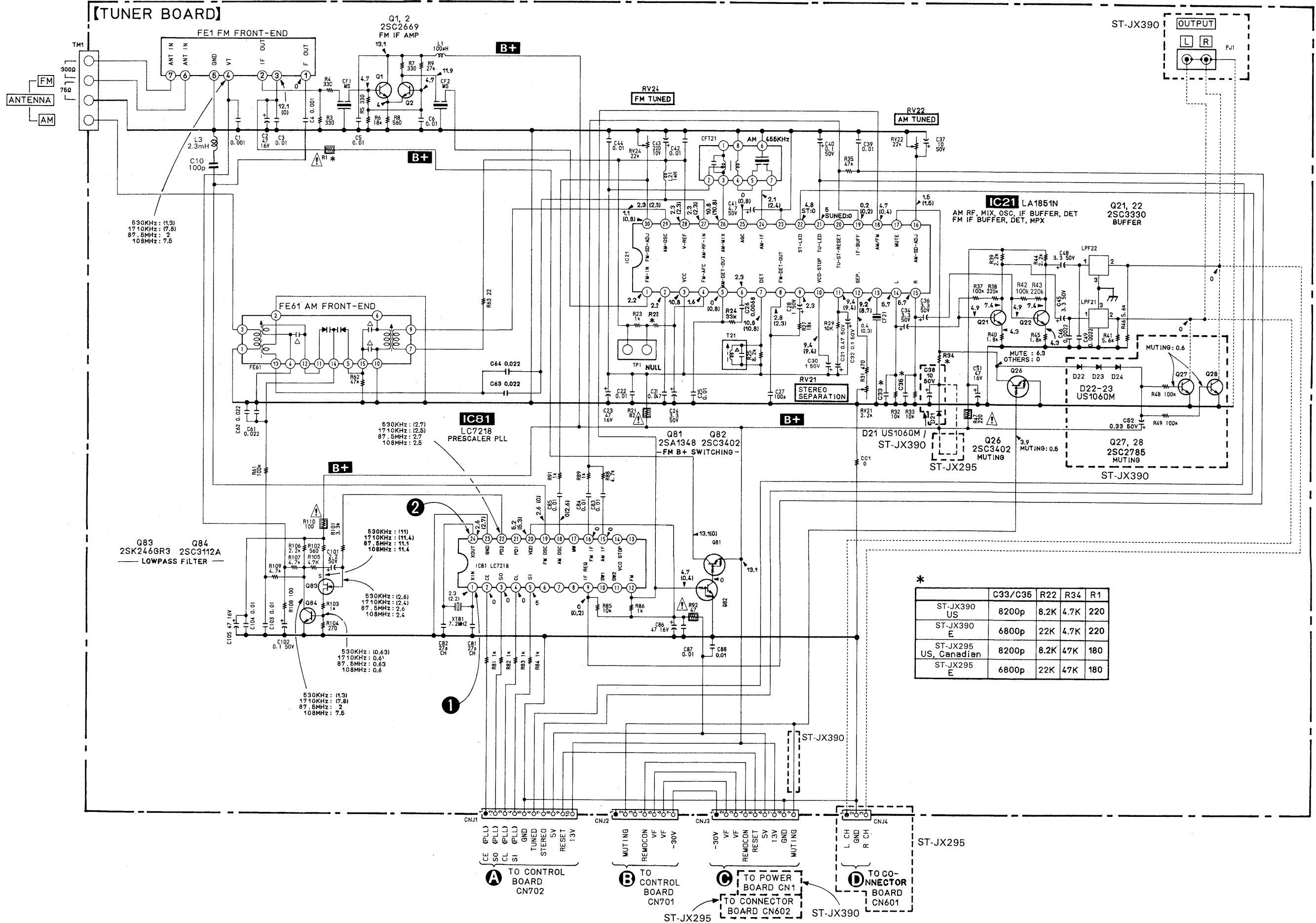

# [ELECTRICAL PARTS LIST]

## NOTE:

- Due to standardization, replacements in the parts list may be different from the parts specified in the diagrams or the components used on the set.
- Items marked "★" are not stocked since they are seldom required for routine service. Some delay should be anticipated when ordering these items.
- If there are two or more same circuits in a set such as a stereophonic machine, only typical circuit parts may be indicated and capacitors and resistors in other same circuits may be omitted.

CAPACITORS:  
MF:  $\mu$ F, PF:  $\mu$ MF.

RESISTORS  
• All resistors are in ohms.  
• F: nonflammable

COILS  
• MMH: mH, UH:  $\mu$ H

SEMICONDUCTORS  
In each case, U:  $\mu$ , for example:  
UA...:  $\mu$ A..., UPA...:  $\mu$ PA...,  
UPC...:  $\mu$ PC, UPD...:  $\mu$ PD...

The components identified by mark  $\Delta$  or dotted line with mark  $\Delta$  are critical for safety. Replace only with part number specified.

Les composants identifiés par une marque  $\Delta$  sont critiques pour la sécurité. Ne les remplacer que par une pièce portant le numéro spécifié.

Ref.No.	Part No.	Description	Ref.No.	Part No.	Description
904	* A-4303-238-A	(JX295: US Canadian)...MOUNTED PCB TUNER	C49	1-162-524-11	CERAMIC CHIP 0.0022MF 20% 25V
	* A-4303-239-A	(JX295: E).....MOUNTED PCB TUNER	C51	1-124-477-11	CAP, ELECT 47MF 20% 16V
	* A-4303-236-A	(JX390: US).....MOUNTED PCB TUNER	C52	1-123-609-11	(JX390)...CAP, ELECT 0.33MF 20% 50V
	* A-4303-237-A	(JX390: E).....MOUNTED PCB TUNER	C61	1-163-063-00	CERAMIC MELF 0.022MF 25V
C1	1-162-294-31	CERAMIC CHIP 0.001MF 20% 25V	C62	1-163-063-00	CERAMIC MELF 0.022MF 25V
C2	1-124-477-11	CAP, ELECT 47MF 20% 16V	C63	1-163-063-00	CERAMIC MELF 0.022MF 25V
C3	1-163-059-00	CERAMIC MELF 0.01MF 20% 16V	C64	1-163-063-00	CERAMIC MELF 0.022MF 25V
C4	1-162-294-31	CERAMIC CHIP 0.001MF 20% 25V	C81	1-102-961-00	CAP, CERAMIC 27PF 5% 50V
C5	1-163-059-00	CERAMIC MELF 0.01MF 20% 16V	C82	1-102-961-00	CAP, CERAMIC 27PF 5% 50V
C6	1-163-059-00	CERAMIC MELF 0.01MF 20% 16V	C83	1-163-059-00	CERAMIC MELF 0.01MF 20% 16V
C10	1-162-516-11	CERAMIC CHIP 100PF 10% 50V	C84	1-163-059-00	CERAMIC MELF 0.01MF 20% 16V
C9	1-163-059-00	CERAMIC MELF 0.01MF 20% 16V	C85	1-163-059-00	CERAMIC MELF 0.01MF 20% 16V
C21	1-161-021-11	CAP, CERAMIC 0.047MF 10% 25V	C86	1-124-477-11	CAP, ELECT 47MF 20% 16V
C22	1-163-059-00	CERAMIC MELF 0.01MF 20% 16V	C87	1-163-059-00	CERAMIC MELF 0.01MF 20% 16V
C23	1-124-477-11	CAP, ELECT 47MF 20% 16V	C88	1-163-059-00	CERAMIC MELF 0.01MF 20% 16V
C24	1-123-382-00	CAP, ELECT 3.3MF 20% 50V	C101	1-124-925-11	CAP, ELECT 2.2MF 20% 50V
C25	1-163-059-00	CERAMIC MELF 0.01MF 20% 16V	C102	1-124-463-00	CAP, ELECT 0.1MF 20% 50V
C26	1-162-527-11	CERAMIC CHIP 0.0068MF 20% 12V	C105	1-124-477-11	CAP, ELECT 47MF 20% 16V
C27	1-162-516-11	CERAMIC CHIP 100PF 10% 50V	C103	1-163-059-00	CERAMIC MELF 0.01MF 20% 16V
C28	1-124-499-11	CAP, ELECT 1.0MF 20% 50V	C104	1-163-059-00	CERAMIC MELF 0.01MF 20% 16V
C30	1-124-499-11	CAP, ELECT 1.0MF 20% 50V	CC11	1-249-366-11	CARBON MELF 0 5% 1/5W
C31	1-124-902-00	CAP, ELECT 0.47MF 20% 50V	CF1	1-567-389-11	FILTER, CERAMIC
C32	1-124-463-00	CAP, ELECT 0.1MF 20% 50V	CF2	1-567-389-11	FILTER, CERAMIC
C33	1-130-481-91	(JX390/JX295:E)...CAP, PE TEREPHTHALATE 00068MF 5% 50V	CF21	1-577-075-11	OSCILLATOR, CERAMIC
C33	1-130-482-00	(JX390:US/JX295:US,Canadian)...CAP, PE TEREPHTHALATE 0.0082MF 5% 50V	CF701	1-577-359-21	VIBRATOR, CERAMIC
C34	1-123-382-00	CAP, ELECT 3.3MF 20% 50V	CFT21	1-404-853-11	TRANSFORMER, IF (CERAMIC FILTER)
C35	1-130-481-91	(JX390/JX295:E)...CAP, PE TEREPHTHALATE 00068MF 5% 50V	CNJ1	*1-568-276-11	SOCKET, CONNECTOR 10P
C35	1-130-482-00	(JX390:US/JX295:US,Canadian)...CAP, PE TEREPHTHALATE 0.0082MF 5% 50V	CNJ2	*1-568-273-11	SOCKET, CONNECTOR 7P
C36	1-123-382-00	CAP, ELECT 3.3MF 20% 50V	CNJ3	*1-568-275-11	SOCKET, CONNECTOR 9P
C37	1-123-875-11	CAP, ELECT 10MF 20% 50V	CNJ4	1-568-269-11	(JX295)...SOCKET, CONNECTOR 3P
C38	1-123-875-11	(JX390)...CAP, ELECT 10MF 20% 50V	D21	8-719-000-26	(JX390)...DIODE U1060M
C39	1-163-059-00	CERAMIC MELF 0.01MF 20% 16V	D22	8-719-000-26	(JX390)...DIODE U1060M
C40	1-124-463-00	CAP, ELECT 0.1MF 20% 50V	D23	8-719-000-26	(JX390)...DIODE U1060M
C41	1-124-927-11	CAP, ELECT 4.7MF 20% 50V	D24	8-719-000-26	(JX390)...DIODE U1060M
C42	1-163-059-00	CERAMIC MELF 0.01MF 20% 16V	FE1	1-463-962-21	FRONT END, FM
C43	1-126-176-11	CAP, ELECT 220MF 20% 10V	FE61	1-236-461-11	ENCAPSULATED COMPONENT
C44	1-163-059-00	CERAMIC MELF 0.01MF 20% 16V	IC21	8-759-821-45	IC LA1851N
C45	1-123-382-00	CAP, ELECT 3.3MF 20% 50V	IC81	8-759-820-91	IC LC7218
C46	1-162-524-11	CERAMIC CHIP 0.0022MF 20% 25V	L1	1-410-521-11	MICRO INDUCTOR 100UH
C48	1-123-382-00	CAP, ELECT 3.3MF 20% 50V	L21	1-410-171-11	MICRO INDUCTOR 1MMH
			LPF21	1-235-164-00	FILTER, LOW PASS
			LPF22	1-235-164-00	FILTER, LOW PASS
			PJ1	1-565-352-21	(JX390)...JACK, PIN 2P

Ref.No.	Part No.	Description
Q1	8-729-266-93	TRANSISTOR 2SC2669
Q2	8-729-266-93	TRANSISTOR 2SC2669
Q21	8-729-119-78	TRANSISTOR 2SC2785-HFE
Q22	8-729-119-78	TRANSISTOR 2SC2785-HFE
Q26	8-729-900-80	TRANSISTOR DT C114ES
Q27	8-729-620-05	(JX390)...TRANSISTOR 2SC2603-EF
Q28	8-729-620-05	(JX390)...TRANSISTOR 2SC2603-EF
Q81	8-729-806-10	TRANSISTOR 2SA1348
Q82	8-729-900-80	TRANSISTOR DT C114ES
Q83	8-729-202-67	TRANSISTOR 2SK246GR3
Q84	8-729-201-84	TRANSISTOR 2SC3112-13
R1	△ 1-249-409-11	RES, CARBON (SMALL) 220 5% 1/4W F
R3	1-249-329-11	CARBON MELF 330 5% 1/8W
R4	1-249-329-11	CARBON MELF 330 5% 1/8W
R5	1-249-329-11	CARBON MELF 330 5% 1/8W
R6	1-249-350-11	CARBON MELF 18K 5% 1/8W
R7	1-249-329-11	CARBON MELF 330 5% 1/8W
R8	1-249-332-11	CARBON MELF 560 5% 1/8W
R9	1-249-352-11	CARBON MELF 27K 5% 1/8W
R21	△ 1-249-404-00	RES, CARBON (SMALL) 82 5% 1/4W F
R22	1-249-428-11	(JX390:US/JX295:US,Canadian) ...RES, CARBON (SMALL) 8.2K 5% 1/4W
R22	1-249-433-00	(JX390/JX295:E) ...RES, CARBON (SMALL) 22K 5% 1/4W
R23	1-249-335-11	CARBON MELF 1K 5% 1/8W
R24	1-249-353-11	CARBON MELF 33K 5% 1/8W
R25	1-249-346-11	CARBON MELF 8.2K 5% 1/8W
R27	1-249-350-11	CARBON MELF 18K 5% 1/8W
R29	1-249-347-11	CARBON MELF 10K 5% 1/8W
R31	1-249-331-11	CARBON MELF 470 5% 1/8W
R32	1-249-347-11	CARBON MELF 10K 5% 1/8W
R33	1-249-347-11	CARBON MELF 10K 5% 1/8W
R34	1-249-425-11	(JX390)...RES, CARBON(SMALL) 4.7K
R34	1-249-437-11	(JX295)...RES, CARBON(SMALL) 47K 5% 1/4W
R35	1-249-355-11	CARBON MELF 47K 5% 1/8W
R37	1-249-359-11	CARBON MELF 100K 5% 1/8W
R38	1-249-363-11	CARBON MELF 220K 5% 1/8W
R39	1-249-339-11	CARBON MELF 2.2K 5% 1/8W
R40	1-249-338-11	CARBON MELF 1.8K 5% 1/8W
R41	1-249-344-11	CARBON MELF 5.6K 5% 1/8W
R42	1-249-359-11	CARBON MELF 100K 5% 1/8W
R43	1-249-363-11	CARBON MELF 220K 5% 1/8W
R44	1-249-339-11	CARBON MELF 2.2K 5% 1/8W
R45	1-249-338-11	CARBON MELF 1.8K 5% 1/8W
R46	1-249-344-11	CARBON MELF 5.6K 5% 1/8W
R47	△ 1-249-409-11	RES, CARBON (SMALL) 220 5% 1/4W F
R48	1-249-359-11	(JX390)...CARBON MELF 100K 5% 1/8W
R49	1-249-359-11	(JX390)...CARBON MELF 100K 5% 1/8W
R61	1-249-359-11	CARBON MELF 100K 5% 1/8W
R62	1-249-355-11	CARBON MELF 47K 5% 1/8W
R63	1-249-315-11	CARBON MELF 22 5% 1/8W
R81	1-249-335-11	CARBON MELF 1K 5% 1/8W
R82	1-249-335-11	CARBON MELF 1K 5% 1/8W
R83	1-249-335-11	CARBON MELF 1K 5% 1/8W
R84	1-249-335-11	CARBON MELF 1K 5% 1/8W

Ref.No.	Part No.	Description
R85	1-249-347-11	CARBON MELF 10K 5% 1/8W
R86	1-249-335-11	CARBON MELF 1K 5% 1/8W
R87	1-249-347-11	CARBON MELF 10K 5% 1/8W
R88	1-249-343-11	CARBON MELF 4.7K 5% 1/8W
R89	1-249-335-11	CARBON MELF 1K 5% 1/8W
R90	1-249-347-11	CARBON MELF 10K 5% 1/8W
R91	1-249-335-11	CARBON MELF 1K 5% 1/8W
R92	△ 1-249-401-11	RES, CARBON (SMALL) 47 5% 1/4W F
R101	1-249-341-11	CARBON MELF 3.3K 5% 1/8W
R102	1-249-332-11	CARBON MELF 560 5% 1/8W
R103	1-249-335-11	CARBON MELF 1K 5% 1/8W
R104	1-249-328-11	CARBON MELF 270 5% 1/8W
R105	1-249-343-11	CARBON MELF 4.7K 5% 1/8W
R106	1-249-339-11	CARBON MELF 2.2K 5% 1/8W
R107	1-249-343-11	CARBON MELF 4.7K 5% 1/8W
R108	1-249-323-11	CARBON MELF 100 5% 1/8W
R109	1-249-343-11	CARBON MELF 4.7K 5% 1/8W
R110	△ 1-249-405-11	RES, CARBON (SMALL) 100 5% 1/4W F
RV21	1-238-013-11	RES, ADJ, CARBON 2.2K
RV22	1-238-017-11	RES, ADJ, CARBON 22K
RV24	1-238-017-11	RES, ADJ, CARBON 22K
T21	1-404-807-11	TRANSFORMER, DISCRIMINATOR
TMI	1-536-708-00	TERMINAL BOARD, PUSH 4P
TP1	*1-560-060-00	PIN, CONNECTOR 2P
XT81	1-577-126-11	VIBRATOR, CRYSTAL

**Note:**

The components identified by mark **△** or dotted line with mark **△** are critical for safety. Replace only with part number specified.

**Note:**

Les composants identifiés par une marque **△** sont critiques pour la sécurité. Ne les remplacer que par une pièce portant le numéro spécifié.