

STR-6040



Specifications

- Frequency range (FM):** 87 to 108 MHz
- Usable sensitivity (FM):** $2.0 \mu\text{V} \pm 1 \text{ dB}$, IHF
- Selectivity (FM):** 70 dB, IHF
- Frequency range (A-M):** 530 to 1,605 kHz
- Sensitivity (A-M):** 48 dB above $1 \mu\text{V}$ ($251 \mu\text{V}$), built-in antenna
26 dB above $1 \mu\text{V}$ ($20 \mu\text{V}$), external antenna
- Dynamic power:** $32 \text{ W} \pm 0.5 \text{ dB}$, both channels, 8 ohms, IHF
- Rated output:** $15 \text{ W} \pm 0.5 \text{ dB}$, each channel, 8 ohms
- THD (Audio):** Less than 0.5 % at 1 kHz at rated output
- IMD (Audio):** Less than 0.5 % at rated output
- Power consumption:** Approx. 60 W, UL Model
70 VA (CSA Standard), CSA Model
110 W (IEC Standard), General Export Model
- Power requirement:** 117 V, UL & CSA Model
100, 117, 220, 240 V, General Export Model
- Dimensions:** $15\text{-}3/4"$ (width) \times $5\text{-}3/4"$ (height) \times $12\text{-}1/4"$ (depth)
400 mm (width) \times 145 mm (height) \times 310 mm (depth)
- Weight:** 16 lb
7.25 kg

SONY[®]
SERVICE MANUAL

TABLE OF CONTENTS

	<i>Page</i>
SECTION 1 CIRCUIT DESCRIPTION	
1-1. Technical Specifications	1
1-2. Circuit Features	2
1-3. Detailed Circuit Operation	2
SECTION 2 DISASSEMBLY AND PARTS REPLACEMENT	
2-1. Top Cover and Bottom Plate Removal	8
2-2. Front Panel Removal	8
2-3. Front-panel Assembly Removal	8
2-4. Switch and Jack Replacement	10
2-5. Pilot Lamp Replacement	10
2-6. Power Transistor Replacement	11
2-7. Dial Glass Replacement	11
2-8. Dial Cord Stringing	11
SECTION 3 ALIGNMENT PROCEDURES	
3-1. Fm Discriminator	14
3-2. Fm Tuner Front-end	15
3-3. A-m I-f Strip	16
3-4. A-m Tuner Frequency Coverage and Tracking	17
SECTION 4 OVERALL ADJUSTMENTS AND TESTS	
4-1. Fm Discriminator Adjustment	19
4-2. Fm Monaural Distortion	20
4-3. Fm Stereo Distortion	20
4-4. Channel Separation	21
4-5. Dial Pointer Calibration	21
4-6. Power Amplifier	21
CHASSIS LAYOUT	23
LEVEL DIAGRAM	24
BLOCK DIAGRAM	25
MOUNTING DIAGRAM	
A-m CP/I-f Amplifier Board	27
Fm I-f Amplifier Board	29
Fm Front-end Section	31
Multiplex Decoder and Equalizer Amplifier Board	32
SCHEMATIC DIAGRAM, Tuner Section	34
MOUNTING DIAGRAM	
Tone Control and Flat Amplifier Board	36
Power Amplifier Board	37
Power Supply Board	39
SCHEMATIC DIAGRAM, Audio Amplifier Section	40
EXPLODED VIEW (1)	43
EXPLODED VIEW (2)	45
REPLACEMENT PARTS LIST	42, 44, 46

SECTION 1

CIRCUIT DESCRIPTION

1-1. TECHNICAL SPECIFICATIONS

FM Tuner

Frequency range	: 87 to 108 MHz
Intermediate frequency	: 10.7 MHz
Usable sensitivity	: $2.0 \mu\text{V} \pm 1 \text{ dB}$, IHF
Signal-to-noise ratio	: 70 dB
Capture ratio	: 2.0 dB
Selectivity	: 70 dB, IHF
Image rejection	: 60 dB
I-f rejection	: 90 dB
Spurious rejection	: 100 dB
A-m suppression	: 50 dB
Frequency response	: 30 to 15,000 Hz $\pm 1 \text{ dB}$
Antenna	: 300 ohms balanced
Harmonic distortion	: Mono: 0.4%, 400 Hz Stereo: 0.5%, 400 Hz
Fm stereo separation	: Greater than 40 dB at 1 kHz
Stereo automatic switching level	: $5 \mu\text{V}$ 19 kHz, 38 kHz
suppression	: 54 dB

A-M Tuner

Frequency range	: 530 to 1,605 kHz
Intermediate frequency	: 455 kHz
Sensitivity	: 48 dB above $1 \mu\text{V}$ (251 μV), built-in antenna 26 dB above $1 \mu\text{V}$ (20 μV), external antenna
Signal-to-Noise ratio	: 46 dB at 5 mV input
Image rejection	: 47 dB at 600 kHz 45 dB at 1,400 kHz
I-f rejection	: 40 dB at 1,000 kHz
Harmonic distortion	: 0.8% at 5 mV input

Audio Amplifier

Dynamic power	: 32 W $\pm 0.5 \text{ dB}$, IHF, into 8 ohms, 0.5% THD, both channels
---------------	---

Rated Output	: 4 ohms: 14 W each ch. 8 ohms: 15 W each ch. 16 ohms: 13 W each ch.
Power bandwidth	: 30 Hz to 40 kHz, 8 ohms, IHF
Total harmonic distortion	: Less than 0.5% at 1 kHz at rated output Less than 0.1% at 1 kHz at 1 W output
IM distortion (SMPTE)	: Less than 0.5% at rated output Less than 0.2% at 1 W output
Frequency response	: PHONO: RIAA equalization curve. Tuner, TAPE, AUX 1, 2: 20 Hz to 50 kHz (-3 dB) REC/PB(input): 20 Hz to 50 kHz (-3 dB)
Input sensitivity and impedance	: PHONO: 2.5 mV 47 k AUX 1, 2: 250 mV 100 k TAPE: 250 mV 100 k REC/PB: 250 mV 100 k
Output voltage	: REC OUT: 250 mV 10 k REC/PB: 35 mV 80 k
Signal-to-noise ratio	: PHONO: greater than 70 dB AUX 1, 2: greater than 70 dB TAPE: greater than 90 dB REC/PB(input): greater than 90dB IHF (using weighting net- work A)
Tone control	: BASS $\pm 10 \text{ dB}$ at 100 Hz TREBLE $\pm 10 \text{ dB}$ at 10 kHz
Filter	: HIGH 6 dB/oct above 5 kHz

General

Power consumption	: Approx. 60 W, UL 70 VA (CSA Standard), CSA 110 W (IEC Standard), Gen.
Power requirement	: 117 V, UL & CSA 100, 117, 220, 240 V, Gen.
Dimensions	: $15\frac{3}{4}$ " (width) \times $5\frac{3}{4}$ " (height) \times $12\frac{1}{4}$ " (depth) 400 mm (width) \times 145 mm (height) \times 310 mm (depth)
Weight	: 16 lb (7.25 kg)

1-2. CIRCUIT FEATURES

FM Tuner

A triple-tuned passive rf circuit and field-effect transistor give the tuner an excellent figure of merit. The passive rf circuit makes possible excellent sensitivity and selectivity, low cross-modulation, and high overload capacity.

A newly-designed fm local-oscillator circuit provides drift-free operation, eliminating the need for automatic frequency control.

Seven i-f stages using six ceramic filters ensure good selectivity, sharp skirt response, and essentially flat response within the selected channel.

An electronic switching system in the multiplex decoder section switches the receiver to stereo or monaural automatically, according to the characteristics of the received signal.

A-M Tuner

Two ceramic filters are used in the a-m tuner section for good selectivity and adjacent channel rejection. An FET is used to improve the agc response for distortionless reception.

Control Amplifier

The amplifier delivers up to 32 watts of dynamic power (16 watts each channel) to an 8-ohm load (measured according to IHF standards). The amplifier section consists of a flat amplifier, and a power amplifier with an effective power-transistor protection circuit.

All equalization, filtering and tone-control functions are performed by passive R-C networks, with two feedback-stabilized direct-coupled amplifiers between them for isolation and gain.

1-3. DETAILED CIRCUIT OPERATION

The following describes the functions of all stages and controls. The text sequence follows signal paths. Stages are listed by transistor reference designation at the left margin; major components are also listed in a similar manner. Refer to the block diagram on page 25 and the schematic diagram on page 34 and 40.

FM FRONT END

Stage/Control	Function
Passive rf circuit L101 to L103	This triple-tuned circuit is used between the antenna and mixer to select the desired signal and suppress all others. It is perfectly linear, and cannot produce distortion and overload components. Thus, the factors that contribute to spurious responses ahead of the mixer are

Stage/Control	Function
Local oscillator Q102	eliminated. Q102 supplies injection voltage to the mixer through L104. The circuit is a modified Hartley oscillator with feedback applied to the emitter of Q102 from the tap on L104. As this oscillator is extremely stable and temperature changes have little effect upon oscillator tuning, AFC is not necessary.
Mixer Q101	Rf signals and local oscillator voltage are heterodyned in field-effect transistor Q101 to produce the 10.7 MHz output. Source injection of the oscillator voltage provides some isolation between the rf tuned circuits and oscillator. IFT101 is a tuned transformer to develop the i-f output and provide a path to ground for the other heterodyne products. A low-impedance output winding feeds the signal to the first i-f amplifier.
I-f amplifier Q103	This stage amplifies the output of the mixer to a level sufficient to drive the main i-f amplifier strip.

FM I-F AMPLIFIER AND DISCRIMINATOR

I-f amplifiers Q201 to Q205	These i-f stages are basically R-C coupled amplifiers that provide the required gain.
Ceramic filters CF201 to CF206	The selectivity of the main i-f strip is determined by the ceramic filters which provide interstage coupling paths. These ceramic filters are made up of two individual sections that operate in a "trapped-energy" mode. The filters provide extremely-sharp skirt selectivity and flat response within the pass band. These filters determine overall selectivity in the fm tuner.
Diode limiters D201 to D206	Limiting is accomplished by pairs of diodes, connected in parallel and opposite in polarity (Fig. 1-1). Each diode conducts when the signal across it exceeds the barrier potential of about 0.6 volts in the forward direction. Thus, the signal is limited in both directions to 1.2

Stage/Control

Function

volts peak to peak. The diodes provide symmetrical limiting.

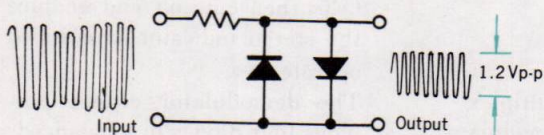

Fig. 1-1 Diode limiter

I-f output
Q206

Signal at the base of Q206 has had all amplitude variations removed by the preceding limiters, and only selected signals have been passed by the solid-state filters. Therefore, the main purpose of Q206 is to provide driving power for the ratio detector.

Tuning meter
M901

This meter is a tuning aid used to obtain optimum reception of fm or a-m stations. It works as follows: An fm i-f component is extracted from the collector of Q204 and converted into a dc voltage by D209. Similarly, an a-m i-f output is taken from the IFT302 secondary winding and converted into dc voltage by D303. The proper dc voltage is then supplied to M901 via FUNCTION switch S2. These dc voltages are directly proportional to their rf-input signal strength because the preceding i-f stages have a fixed gain.

Ratio detector
T201,
D207, D208

Transformer T201 and diodes D207 and D208 form a balanced ratio detector that transforms the frequency-modulated signal into an audio signal.

MULTIPLEX DECODER

SCA trap
L402, C426

Parallel circuit of L402 and C426 effectively blocks SCA interference with a resonant circuit in the emitter of Q401.

Signal separator
Q401

This stage serves two functions. It extracts the 19 kHz pilot carrier by means of a tuned circuit at its collector, and provides a low-impedance source of composite stereo signal (without the pilot carrier) at its emitter.

Stage/Control

Function

Frequency doubler
D401, D402

Signals developed at the collector of Q401 are transformer-coupled to a full-wave rectifier consisting of diodes D401 and D402. The output of these rectifiers is not filtered, resulting in two positive pulses for each input cycle, as shown in Fig. 1-2. Therefore, the 19 kHz frequency of the pilot carrier is effectively doubled by D401 and D402. However, the waveform is not sinusoidal at the base of Q402.

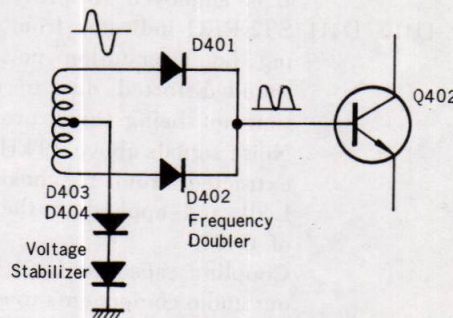

Fig. 1-2 Frequency doubler

38 kHz amplifier

The 38 kHz pulses produced by D401 and D402 are amplified by Q402. At its collector a tank circuit is tuned to 38 kHz to restore these pulses to a sine wave signal. This signal is transformer-coupled to the bridge-type demodulator to supply sampling drive.

STEREO lamp
circuit
Q403

The STEREO indicator lights when an fm stereo signal is received. As shown in Fig. 1-3,

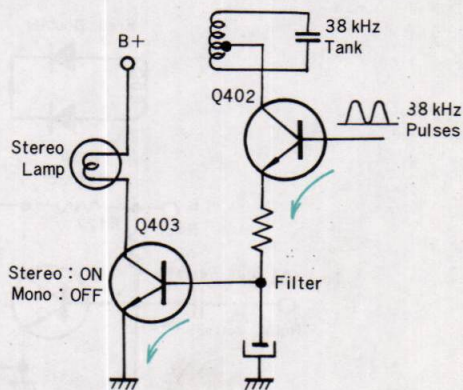

Fig. 1-3 Stereo lamp circuit

Stage/Control

Function

the emitter of Q402 is connected to the base of Q403, which is normally cutoff. The circuit operates as follows: When a composite stereo signal is applied to the multiplex decoder, the 38 kHz pulses produced at the output of the frequency doubler yield a higher average current flow through Q402. This forces Q403 into conduction, lighting the STEREO indicator lamp PL904.

Noise amplifier Q404, D409, D410, D411

This circuit, shown in Fig. 1-4, is employed to prevent the STEREO indicator from lighting on interstation noise, or sound distorted due to a station not being tuned properly. Noise signals above 19 kHz are extracted from rf choke coil L401 and applied to the base of Q404.

Coupling capacitor C421 filters out audio components to ensure that the input signal consists primarily of high-frequency noise. This noise signal is amplified by Q404 to drive rectifiers D410 and D411. When interstation noise is received, the dc output of D410 and D411 is fed back to the base of Q404, and drives Q404 into conduction. This in turn shorts the frequency doubler output to ground, preventing operation of the 38 kHz amplifier Q402 and stereo indicator circuit Q403. When a stereo signal is received,

Stage/Control

Function

the signal-to-noise ratio increases, reducing the noise signal at the base of Q404. Q404 then cuts off and enables the stereo indicator circuits to operate.

Multiplex demodulator D405 to D408

The demodulator circuit employs four diodes in a balanced-bridge arrangement. This system has the advantage of cancelling residual rf components (actually 38 kHz signal,

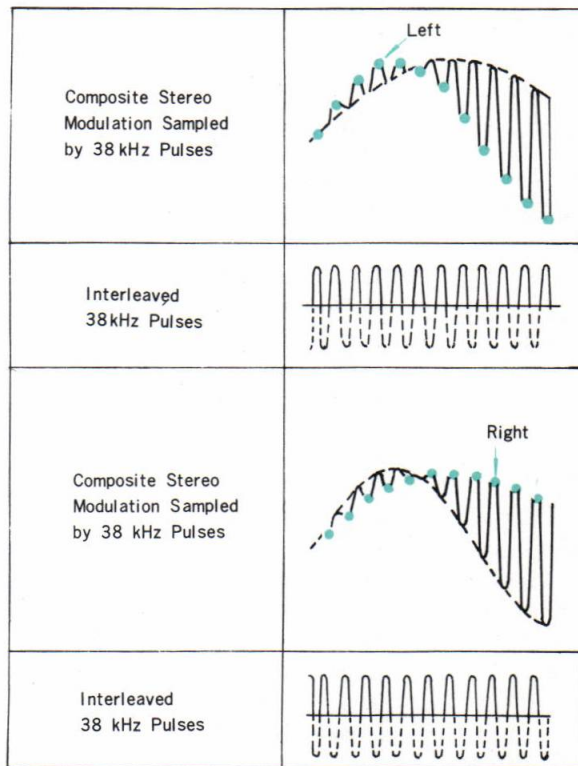

Fig. 1-5 Stereo switching mode

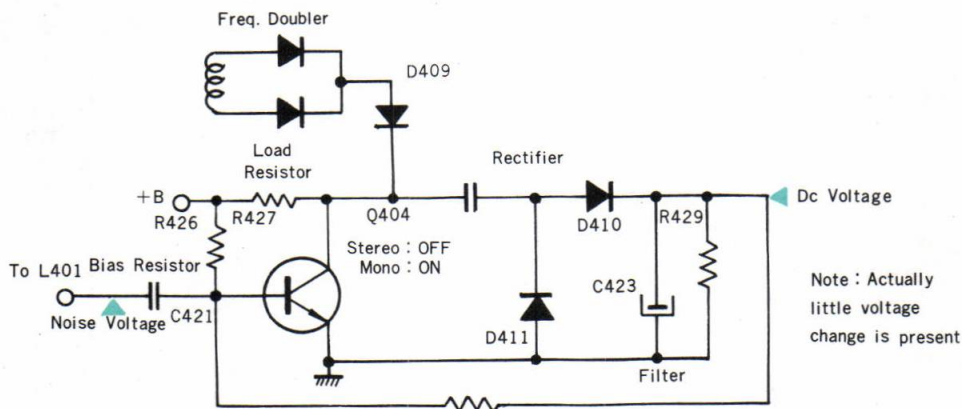

Fig. 1-4 Noise amplifier

Note: Actually little voltage change is present

Stage/Control	Function
	some 19 kHz signal, and higher-order harmonics of these frequencies.)
	"L" and "R" components are developed at each side of the bridge as the result of demodulation when the tuner is operated in the stereo mode (Fig. 1-5). In the monaural mode, diodes D405 and D408 are forward biased by supply voltage through R906, the stereo lamp, R410 and R412, so these diodes act merely as low value resistances. Under this condition, the monaural signal is applied to both "L" and "R" audio amplifiers respectively.
Twin-T filter C411, C412 R417, R416, R419, C414 (C419, C420, R418, R424, R423, C415)	This filter eliminates the 38 kHz carrier component to prevent carrier-leak interference.

A-M TUNER

Local oscillator Q305	This stage supplies injection voltage to the mixer through the secondary winding of L303 (bar antenna). The circuit is a modified Hartley oscillator with feedback applied to the emitter of Q305 from the secondary winding of oscillator coil L304.
Mixer/Amplifier Q301, Q302	Incoming rf signals and local-oscillator voltage are heterodyned in the base-emitter junction of Q301 to produce the 455 kHz output. Transistors Q301 and Q302 form a cascade mixer/amplifier that ensures stable processing of the signals. In addition, an ingenious AGC circuit is incorporated in the cascade amplifier (via Q302) that provides a wide control range in a-m reception.
IFT301	IFT301 is a transformer tuned for 455 kHz. Its low-impedance output winding feeds the signal to i-f amplifier Q303.
I-f amplifier Q303, CF301	This stage is basically an RC coupled amplifier. The selectivity of the stage is determined

Stage/Control	Function
I-f amplifier Q304	by two ceramic filters in its output circuit. Each of these three-section filters provides extremely-sharp skirt selectivity inside the pass band. Transistor Q304 provides the power to drive diode detector D302.
AGC circuit R325, C322 R326, C323	The dc output voltage of detector D302 is fed back to the gate of Q302 through R325 and R326 to control the gain of Q302. The time constants of these resistors and capacitors C322 and C323 determine the AGC response.

AUDIO PREAMPLIFIER

Channel separation adjustment RV504	This network is connected between the emitters of audio preamplifiers Q501 and Q601 in fm stereo reception. It provides a form of negative feedback between the left and right channels. Any residual "L" signals in the "R" channel are cancelled out by the same amount of oppositely phased "L" signal from the "L" channel. The same is true of residual "R" signals in the "L" channel. RV504 is therefore set for maximum channel separation.
Preamplifier (equalizer) Q501 and Q502 (Q601 and Q602)	These stages amplify the small signal produced by the tuner, phono cartridge, tape recorder, or signals applied to the AUX input jacks, to the level required at the input of the driver section. The circuit employs a complicated negative-feedback technique that provides stable operation during temperature changes and good amplification at low-frequencies. It also applies the audio signal to the REC OUT terminal for recording. Preamplifier gain is about 39.2 dB at 1 kHz for the PHONO and tuner inputs. For the AUX inputs, the gain changes to about -0.8 dB. In addition, RIAA equalization is accomplished in this section when FUNCTION switch S1 is in the

Stage/Control	Function
	PHONO position.
R517, R518, C508 to C511 (R617, R618, C608 to C611)	RIAA equalization is achieved by the negative feedback loop containing these components. Use care when replacing any of them.
R519, R520 (R619, R620)	In all positions of the FUNCTION switch except the PHONO position, feedback is applied through R519 or R520 to provide a flat response in the preamplifier. In the PHONO position, specially compensated feedback is applied through a network consisting of resistors R517 and R518, and capacitors C508 to C511 to effect RIAA equalization.
R502 to R505 (R602 to R605)	Signals applied at the AUX 1 and AUX 2 input jacks are attenuated about 40 dB by these resistors. This allows the STR-6040 to accept signals at about 250 mV across these input jacks and amplify them without distortion.
MONITOR switch S3	Switch S3 selects the signals from the TAPE IN jack (TAPE position) or preamplifier output (SOURCE position.)
MODE switch S4	In the STEREO position of S4, left and right input signals are routed to their respective amplifiers. In the MONO position of S4, left and right signals are added and the sum is fed to both amplifier channels.
VOLUME control RV501 (RV601)	The level of signal applied to the power-amplifier section is determined by the setting of RV501 (RV601), which has an audio-taper.
LOUDNESS switch S5, C512, C513 R523, R524 (R623, R624 C612, C613)	These components compensate for human hearing characteristics, which vary according to the loudness of the sound. When this switch is set to the "IN" position, high- and low-frequency components are increased with decreasing volume level. In the IN position of S5 the frequency response changes as follows:

Stage/Control	Function								
	<table border="1"> <thead> <tr> <th>Under 30mW output</th> <th>Under 300mW output</th> </tr> </thead> <tbody> <tr> <td>10dB up at 50Hz</td> <td>5dB up at 50Hz</td> </tr> <tr> <td>0dB at 1kHz</td> <td>0dB at 1kHz</td> </tr> <tr> <td>4.5dB up at 10kHz</td> <td>1.5dB up at 10kHz</td> </tr> </tbody> </table>	Under 30mW output	Under 300mW output	10dB up at 50Hz	5dB up at 50Hz	0dB at 1kHz	0dB at 1kHz	4.5dB up at 10kHz	1.5dB up at 10kHz
Under 30mW output	Under 300mW output								
10dB up at 50Hz	5dB up at 50Hz								
0dB at 1kHz	0dB at 1kHz								
4.5dB up at 10kHz	1.5dB up at 10kHz								
Flat amplifier Q503 (Q603)	This amplifier provides 19 dB voltage gain to compensate for the tone-control insertion loss, and isolates the volume control and tone control to eliminate mutual interference.								
TONE control RV502 (RV602) RV503 (RV603)	RV502 (RV602) controls treble response. It has a range of ± 10 dB at 10 kHz. RV503 (RV603) controls bass response. It has a range of ± 10 dB at 100 Hz.								
HIGH FILTER switch S6	Eliminates unwanted high-frequency components from the input signal (6 dB/octave above 5 kHz) in the ON position.								

AUDIO POWER AMPLIFIER

Flat amplifier Q701 (Q801)	This is a conventional direct-coupled amplifier to drive phase inverter Q702.
Ac balance adjustment RV701 (RV801)	Controls the bias current of Q701 and Q702 to the point where positive and negative half cycles are simultaneously clipped when increasing the input signal. It also affects the rated output power.
Phase inverter Q702 (Q802)	Stage Q702 has two oppositely-phased outputs to drive the power-output stages in push pull. Equal load resistors are used in the collector and emitter circuits to provide equal but oppositely-phased signals at the base of Q704 and Q705.
Dc bias adjustment RV702 (RV802)	Controls the bias current in Q704, Q705, Q706 and Q707 to eliminate crossover distortion at small signal levels.
Negative feedback loop R706, C707	These components provide negative voltage feedback from the output of the power amplifier to the emitter of Q701.
Driver limiter Q703 (Q803)	Q703 limits the amplitude of the positive-going half-cycle drive voltage which causes power transistor damage. This limiter can be considered as an electronic protection circuit based on the principle that power transistor damage usually

Stage/Control**Function**

occurs when power dissipation at the collector exceeds its safety margin. Since collector voltage and collector current determine the power dissipation at the collector, trigger signal for Q703 is taken from the collector and emitter circuit of Q706. The limiting is performed as follows (refer to Fig. 1-6):

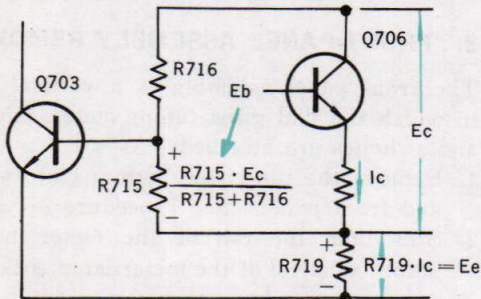

Fig. 1-6 Driver limiter

Under normal condition, Q703 is cut off. When excessive current flows in power transistor Q706, or the power dissipation at the collector of Q706 exceeds its safety margin, Q703 turns on and limits the input drive voltage to protect the power transistors. Though Q703 seems only to be limiting the positive half cycle, it also works for the negative half cycle. C706 discharges during the initial negative half cycle, reducing the center voltage to nearly zero. Since the positive half cycle will not charge C706 due to the limiter's operation, the following negative half cycle can not drive the power transistors.

Drivers

Q704, Q705
(Q804, Q805)

These transistors operate as emitter followers to provide the current swings demanded of the output stages for full output.

Power amplifier

Q706, Q707
(Q806, Q807)

These SONY silicon transistors have been specially manufactured to drive the speaker system at rated output power. Output is coupled to the speakers through C705.

POWER SUPPLY**Stage/Control**

Voltage regulator
Q901, Q902,
D902

Function

Dc output from rectifier D901 is filtered by C902 and applied to series regulator Q901. Q902 compares a sample of the output voltage picked off across R905 with reference voltage supplied by D902. A change in output voltage is detected at the base of Q902, determining the conduction of Q902 and therefore its collector voltage. Since the collector of Q902 is directly coupled to the base of Q901, the change in output voltage alters the conduction of Q901 by the amount necessary to maintain the output voltage constant. An increase in output voltage causes an increase in the impedance (decrease in conduction) of Q901, and vice-versa. The dc output voltage is thus stable and supplied to tuner and preamplifier.

SECTION 2

DISASSEMBLY AND PARTS REPLACEMENT

Warning: Before starting any disassembly or replacement procedures, unplug the ac line cord.

2-1 TOP COVER AND BOTTOM PLATE REMOVAL

1. Remove the two machine screws at each side of the receiver, and lift off the top cover.
2. Remove five Phillips-Head screws (+RF 3×6) at the bottom of the receiver and pull the bottom plate toward the rear of the receiver. See Fig. 2-1.

2-2. FRONT PANEL REMOVAL

1. Remove the top cover. See Procedure 2-1.
2. Remove all control knobs by pulling them out. See Fig. 2-2.
3. Loosen the two screws (+B 3×6); one is just above the VOLUME control shaft and the other is also above the TUNING shaft. See Fig. 2-2.
4. Loosen the two hex nuts that secure the BASS control and rotary FUNCTION switch to the front panel. See Fig. 2-2. Be careful not to scratch or otherwise damage the front panel

5. Remove the front panel and three black pads from the slide switches.

2-3. FRONT-PANEL ASSEMBLY REMOVAL

The front panel assembly is a vertical member to which the dial glass, tuning meter, pilot lamps and switches are attached.

1. Remove the top cover, bottom plate, all knobs and front panel. See Procedure 2-1 and 2-2.
2. Straighten the tab of the meter holder to permit removal of the meter-lamp socket. Pull out the meter-lamp socket.
3. Unhook the dial cord from the dial pointer tab. Mark the dial-pointer position on the dial cord to insure correct reinstallation of the pointer.
4. Loosen the two screws (+RF 3×6) at each side of the chassis as shown in Fig. 2-4.
5. Carefully remove the front panel assembly by pulling it forward and down.

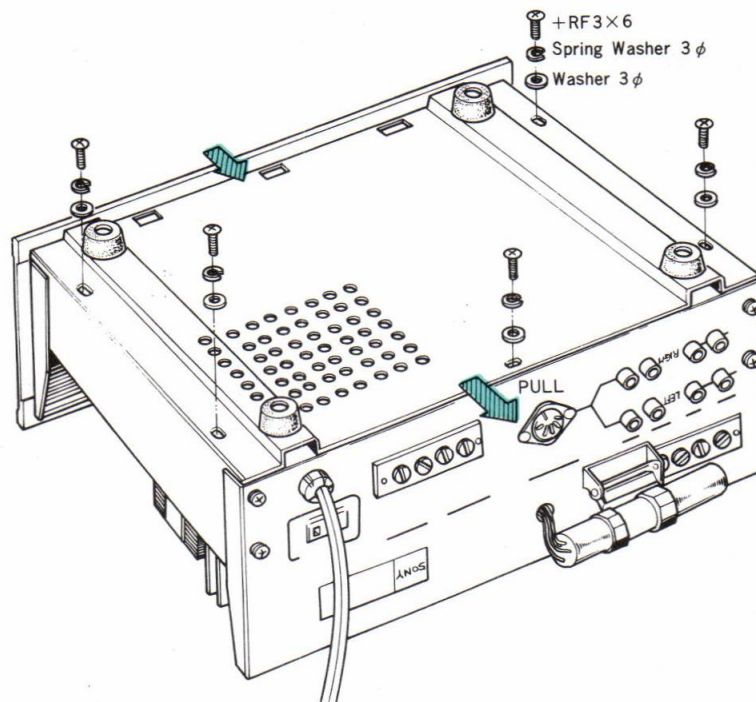

Fig. 2-1 Removal of bottom plate

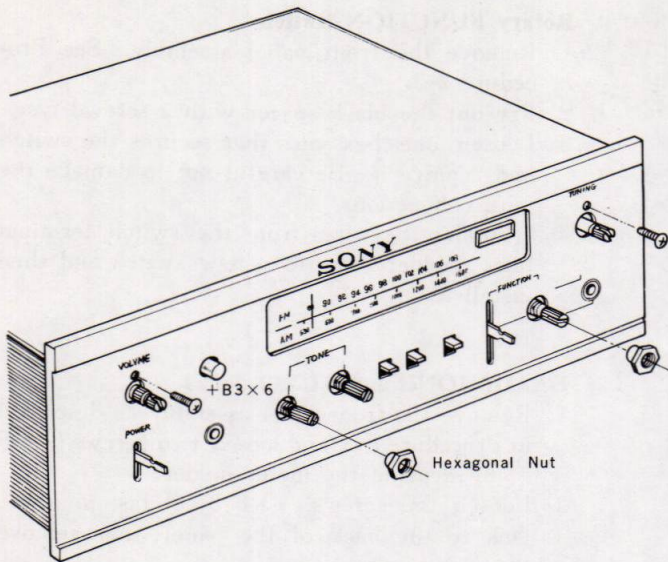

Fig. 2-2 Removal of front panel

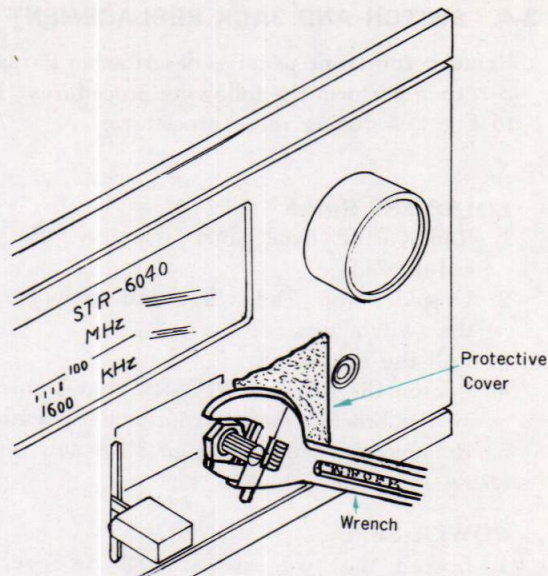

Fig. 2-3 Removal of hexagonal nut

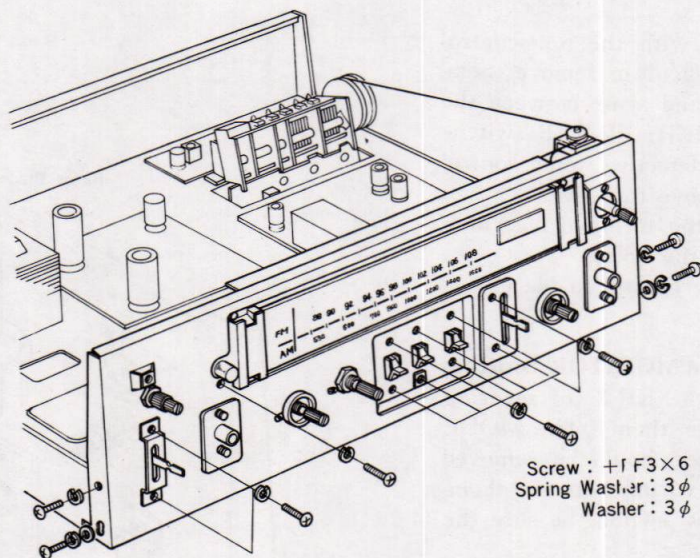

Fig. 2-4 Front panel assembly

2-4. SWITCH AND JACK REPLACEMENT

Remove the front panel as described in Paragraph 2-2, then perform the following procedures. Refer to Fig. 2-4 during these procedures.

LOUDNESS Switch

1. Remove the front-panel assembly. See Procedure 2-3.
2. Unsolder the lead wires and components on the switch lugs.
3. Pull the button off.
4. Loosen the screw (+RF 3×6) that secures the switch bracket to the front-panel assembly.
5. Remove the switch and install a new one.

POWER Switch

1. Loosen the two screws (+RF 3×6) securing the switch. Remove the switch.
2. Unsolder and remove the ac cord and encapsulated component from the switch terminals.
3. Solder the cord and encapsulated component to the new switch.
4. Install the new switch.

TONE Controls

1. Pry out the black spacer with a screwdriver and loosen the two hex nuts securing both controls.
2. Carefully remove them with the tone-control circuit board. If it is difficult to remove them, unsolder the black ground wire between the circuit board and the HIGH FILTER switch.
3. Cut each lug of the defective tone control above the board to remove the part.
4. Unsolder and remove the terminal lugs individually, and clean out the holes.
5. Install and solder a new control in place.

HIGH FILTER, MODE, and MONITOR Switches

1. Loosen the two screws (+RF 3×6) securing each switch and remove them. The MODE and MONITOR switches should be removed together because of the wiring between them.
2. When installing the new switch, be sure the two fiber pads are in place.

Lever-type FUNCTION Switch

1. Loosen the two screws (+RF 3×6) securing the switch and remove it. Be careful not to damage the wire connections.
2. Unsolder the wires from the switch terminal lugs. Solder them to a new switch, and then install it.

Rotary FUNCTION Switch

1. Remove the front panel assembly. See Procedure 2-3.
2. Pry out the black spacer with a screwdriver.
3. Loosen one hex nut that secures the switch and remove it. Be careful not to damage the wire connections.
4. Unsolder the wires from the switch terminal lugs. Solder them to a new switch and then install it.

HEADPHONE and AUX 2 Jacks

1. Remove the front panel assembly as described in Procedure 2-3, and loosen two screws (+RF 3×6) securing the meter holder.
2. Loosen the screws (+RF 3×6) fastening the jack to the back of the panel; then remove the jack.

2-5. PILOT LAMP REPLACEMENT

Meter Lamp

1. Remove the top cover as described in Procedure 2-1.
2. Straighten the tab of the meter holder to permit removal of the meter lamp socket; then pull out the meter lamp socket.
3. Unscrew the lamp and install a new one.

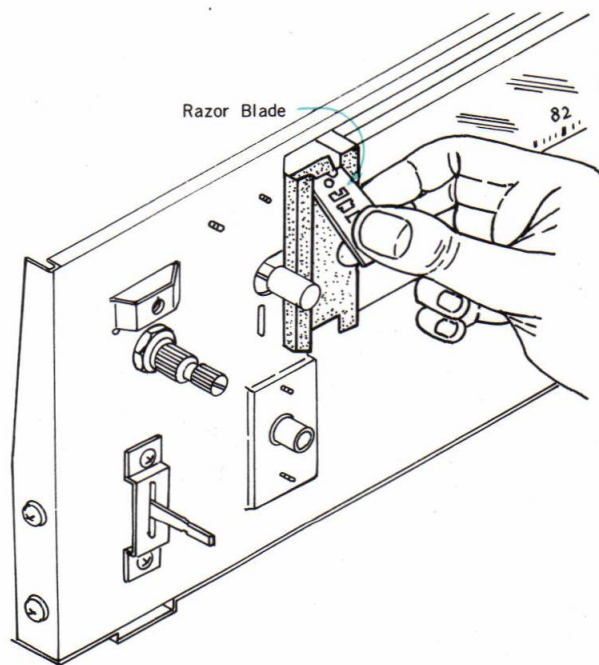

Fig. 2-5 Dial glass lamp replacement

Dial Glass Lamp

1. Remove the front panel as described in Procedure 2-2.
2. Apply a few drops of cement solvent around the fiber lamp shade top and cut through the weakened cement with a razor blade. See Fig. 2-5.
3. Pry out the fiber top, then remove the lamp with a long-nose plier.
4. Install a new lamp, then recement the fiber lamp shade.

STEREO Lamp

1. Remove the top cover. See Procedure 2-1.
2. Loosen two screws (+RF 3×6) that secure the meter holder to the chassis.
3. Turn the meter holder up side down and apply a drop of cement solvent to the stereo lamp holder.
4. Wait a few seconds for the cement to dissolve.
5. Unsolder and remove the defective lamp, then install a new one.

2-6. POWER TRANSISTOR REPLACEMENT

1. Remove the top cover and bottom plate as described in Procedure 2-1.
2. Loosen the two screws (+RF 3×6) that secure the heat sink to the bottom of the chassis.
3. Unsolder and remove the defective transistor, then install a new one.
4. When replacing the power transistor, apply a coating of a heat-transferring silicone grease to both sides of the insulating mica washer.

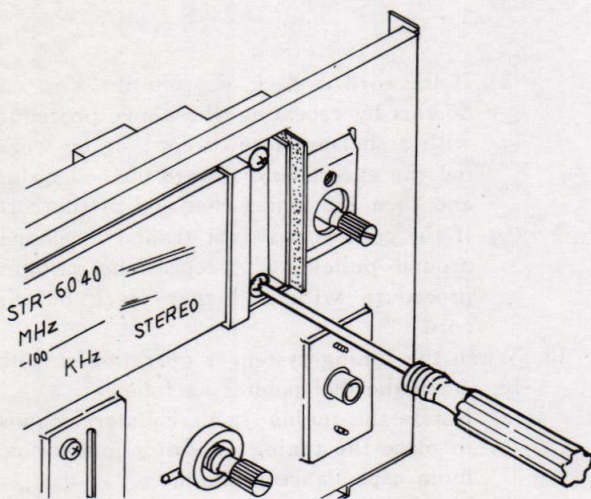

Fig. 2-6 Dial glass replacement

The grease fills in any tiny gaps between the mating surfaces, thereby improving heat transfer to the heat sink.

5. Any excess grease, that is squeezed out when the mounting bolts are tightened, should be wiped off with a clean cloth to prevent it from accumulating conductive dust particles that might eventually cause a short.

2-7. DIAL GLASS REPLACEMENT

1. Remove the front panel as described in Procedure 2-2.
2. Loosen the two self-tapping screws (+RF 3×6), securing the left- and right-side dial-glass holders to the chassis. Figure 2-6 shows the right-side dial-glass holder.
3. Carefully take out the glass and install a new dial glass.

2-8. DIAL CORD STRINGING

1. Remove the top cover as described in Procedure 2-1.
2. Cut a 52-1/2 inch (1,334 mm) length of dial cord.
3. Slowly rotate the tuning-capacitor drive-drum fully counterclockwise to its maximum capacitance position. Be sure that the slot in the drive drum comes to the position as shown in Fig. 2-7.

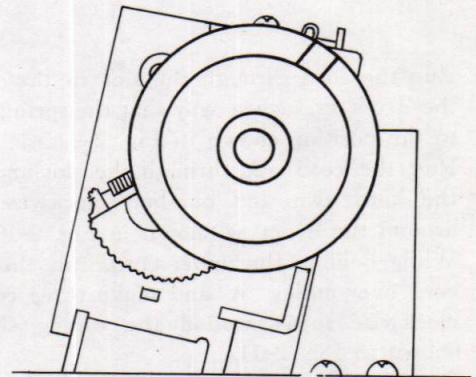

Fig. 2-7 Tuning-capacitor drive-drum installation

4. Make a large knot at each end of the dial cord, then pass the doubled ends of the cord through the two eyelets. Hook each end of the coil spring around one of the cord loops protruding through an eyelet. The dial cord and coil spring now form one large loop as shown in Fig. 2-8.
5. Wind one turn of the cord clockwise around the drum as close to the inner flange as possible. See Fig. 2-9.



Fig. 2-8 Loop of dial cord

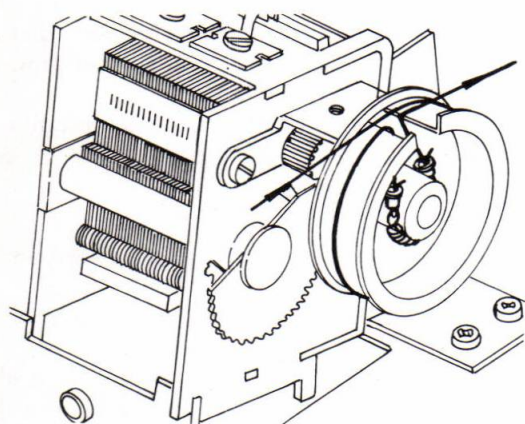

Fig. 2-9 Location of tension spring and dial-cord

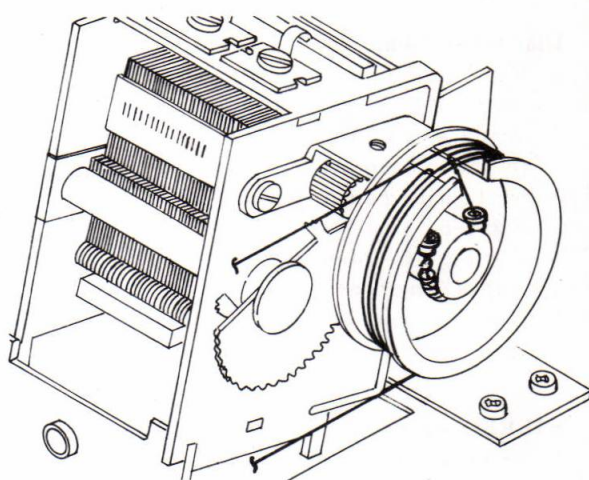

Fig. 2-10 Wrapping dial cord around tuning drum

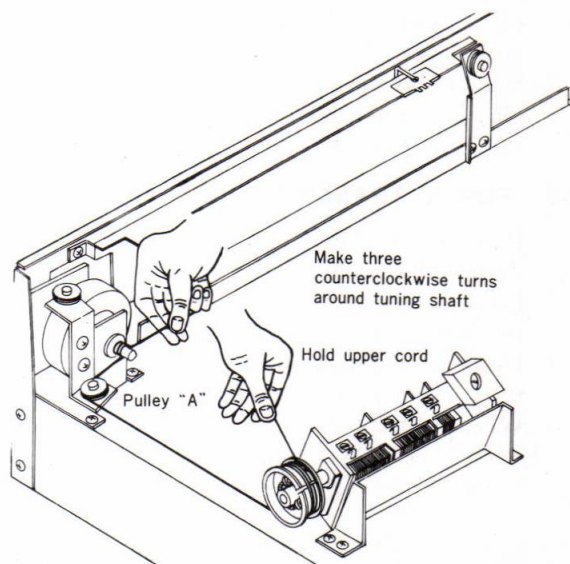

Fig. 2-11 Wrapping dial cord around tuning shaft

6. Run the cord through the slot in the rim of the drum in such a way that the spring comes to the position shown in Fig. 2-9.
7. Run the cord out through the slot and wrap the cord two and one-half clockwise turns around the drum as shown in Fig. 2-10.
8. While holding the upper cord, run the lower cord over pulley "A" and make three counterclockwise turns around the tuning shaft as shown in Fig. 2-11.
9. Run the cord over pulley "B" while maintaining tension on the cord. See Fig. 2-14.
10. Pull the cord while stretching the spring with a pair of needle-nosed pliers or tweezers, then place the cord around pulley "C". See Fig. 2-12 and 2-13.
11. After completing the dial-cord stringing (Fig. 2-14), check out the tuning system for proper operation and apply a drop of contact cement to each eyelet in the drum.
12. In case the system does not work properly, perform the following steps to achieve smooth tuning:

- (a) If the cord is slack, shorten it. You can do this by repeating the above procedure with a shorter piece of cord, or by working the excess cord toward the coil spring, and then shortening that end of the cord.
 - (b) If the cord is too tight (cannot be looped around pulley "C"), repeat the stringing procedure with a longer piece of dial cord.
13. When the tuning system is operating smoothly, attach the dial pointer as follows:
 - (a) Rotate the tuning knob counterclockwise to place the tuning capacitor in its maximum capacitance position.
 - (b) Set the dial pointer to indicate "0" on the logging scale on the dial glass. See Sec-

tion 4, Procedure 4-5 "DIAL CALIBRATION" for accurately locating the dial pointer.

- (c) Run the dial cord over and under the tabs at the rear of the pointer.
- (d) Apply a drop of contact cement to the cord and dial pointer tabs.

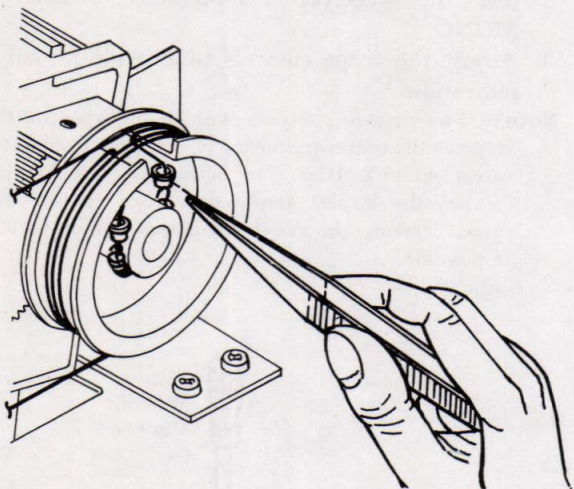

Fig. 2-12 Stretching the tension-spring

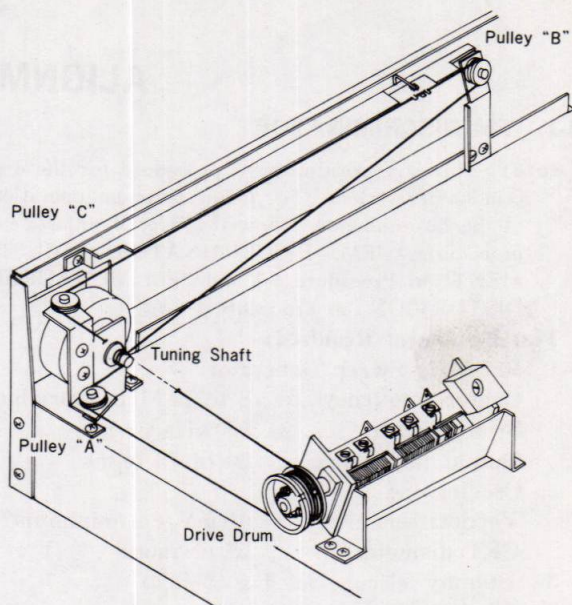

Fig. 2-14 Dial-cord stringing completed

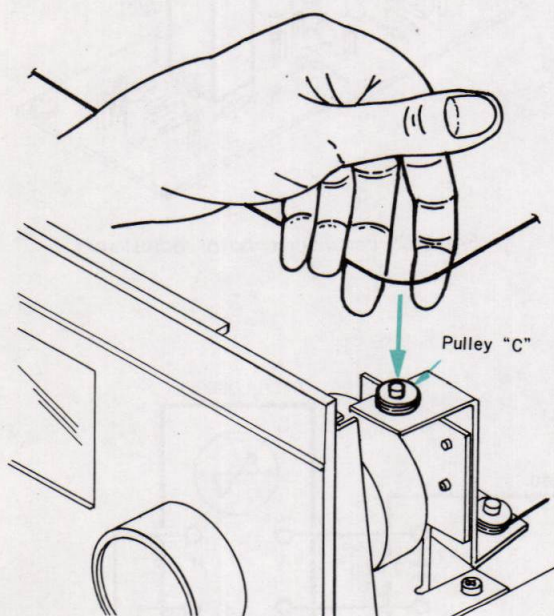

Fig. 2-13 Threading the dial cord over pulley "C"

SECTION 3

ALIGNMENT PROCEDURES

3-1. FM DISCRIMINATOR

Note: This is a preadjustment procedure for the discriminator section. To obtain optimum operation of the discriminator, follow the overall adjustment procedures "FM DISCRIMINATOR ADJUSTMENT" in Procedure 4-1 and "FM MONAURAL DISTORTION" in Procedure 4-2.

Test Equipment Required:

- 10.7 MHz Sweep Generator
Center frequency8 to 12 MHz (variable)
Sweep width:800 kHz or more
Output impedance50 or 75 ohms
- Oscilloscope
Vertical sensitivity10 mV/cm minimum
CRT diameter5" or more
- Dummy circuit See Fig. 3-1.
- Alignment tools

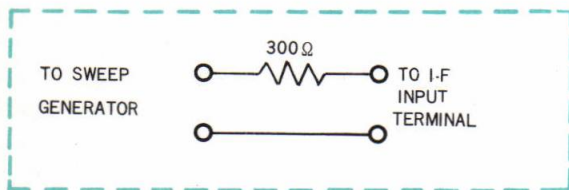

Fig. 3-1 Dummy circuit

Preparation:

- Remove the top cover and bottom plate as described in Procedure 2-1.
- Unsolder the coaxial cable from the input and output terminals of the i-f and discriminator board.
- Connect the dummy circuit between the sweep generator and the input terminals of the i-f and discriminator board.
- Connect the capacitor ($0.02 \mu\text{F}$) to the output terminals of the i-f and discriminator board.

Procedures:

- With the equipment connected as shown in Fig. 3-2, set the 10.7 MHz sweep generator controls as follows:
Center frequency.....10.7 MHz
Sweep width800 kHz or 1.0 MHz
Output levelas low as possible
- Set the receiver FUNCTION switch to MONO.
- Adjust the scope controls to provide a visible indication.

Note: Two or three outputs will be observed on the scope as the center frequency of the sweep generator varies ± 1 to 2 MHz. The output you are looking for has the largest amplitude. Once you get this curve, decrease the sweep generator output as low as possible.

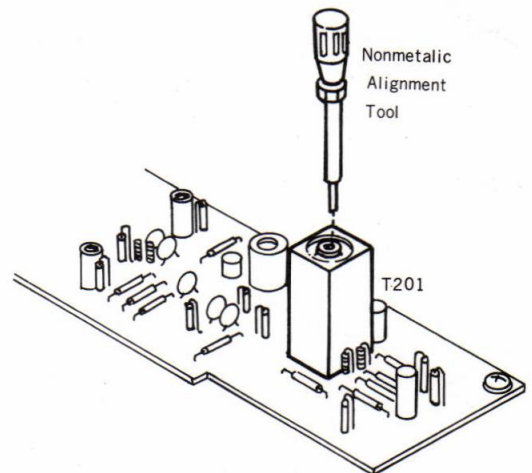

Fig. 3-3 Fm discriminator adjustment

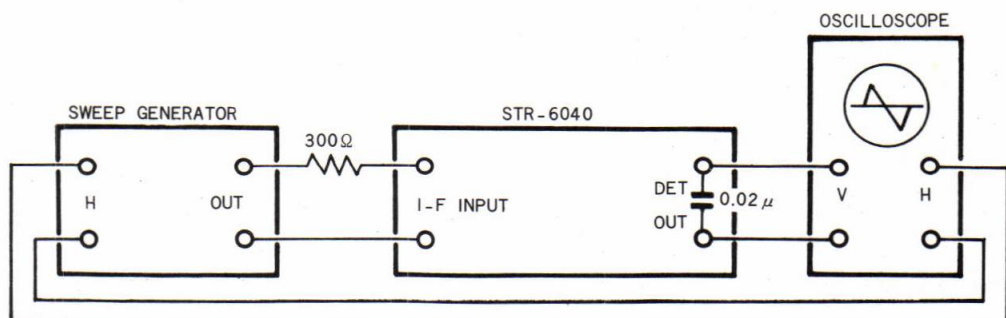

Fig. 3-2 Fm discriminator adjustment test set-up

4. Turn the top core of transformer T201 with the hexagonal-head alignment tool (as shown in Fig. 3-3) to obtain an "S" curve response (as shown in Fig. 3-4).
 5. Turn the bottom core of T201 to obtain a maximum amplitude indication.
 6. Turn the top core slightly to equalize negative and positive peaks as shown in Fig. 3-4.
- $$\frac{A}{2} = B = C$$
7. Disconnect the sweep generator and make sure that the scope displays only noise.

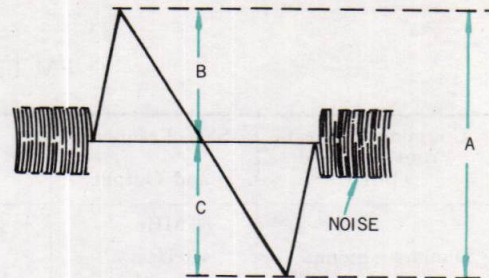

Fig. 3-4 "S"-curve response

3-2. FM TUNER FRONT-END

Never attempt alignment of the front-end section except for the frequency-coverage and dial-calibration adjustments. The front-end section of the tuner has been carefully adjusted at the factory, so very little adjustment is necessary in field. Alignment need not be performed when front-end FETs have been replaced since changes in FET parameters have little effect upon tuning. In case an rf stage adjustment is required, ask your nearest SONY Service Station to send your unit to the Factory Service Center for a complete front-end alignment. Exercise caution when returning the faulty unit so that it is not damaged in transit. The warranty will not cover damage incurred in transit to the Factory Service Center.

Note. Discriminator alignment should be performed first.

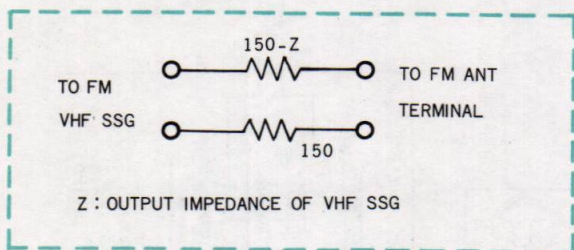

Fig. 3-5 Dummy antenna

Test Equipment Required:

1. FM standard signal generator. If such a generator is unavailable, off-the-air signals at each end of the band will suffice.
2. Dummy antenna See Fig. 3-5.
3. Ac VTVM.
4. Alignment tools.

Preparation:

1. Remove the top cover as described in Paragraph 2-1.
 2. Connect the equipment as shown in Fig. 3-6.
 3. Set the receiver's controls as follows:
 FUNCTION switchMONO
 VOLUME controlMinimum
- Follow the procedures given in Table 1 on next page.

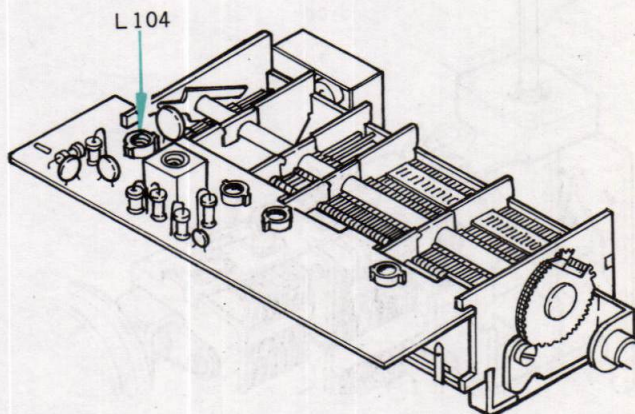

Fig. 3-7 Location of fm oscillator coil L104

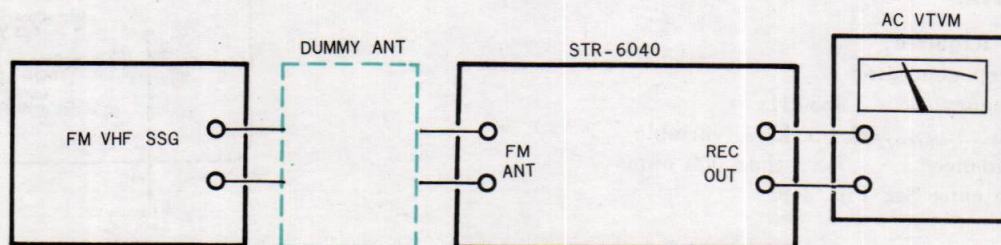

Fig. 3-6 Front end alignment test set-up

TABLE 1
 FM Frequency Coverage Adjustment

Coupling Between Front End and SSG	SSG Frequency and Output	Tuning Capacitor	AC VTVM Connection	Adjust	Indication
Dummy antenna Fig. 3-5	86 MHz 400 Hz 100 % Mod 20 dB/ μ (10 μ V)	Maximum capacitance position	REC OUT J 504	OSC coil L 104 Fig. 3-7	Maximum VTVM reading
Same as above	109.5 MHz 400 Hz 100 % Mod 20 dB/ μ (10 μ V)	Minimum capacitance position	REC OUT J 504	OSC trimmer CT 104 Fig. 3-8	Same as above

Note: Repeat the foregoing procedure several times until accurate dial calibration is observed.

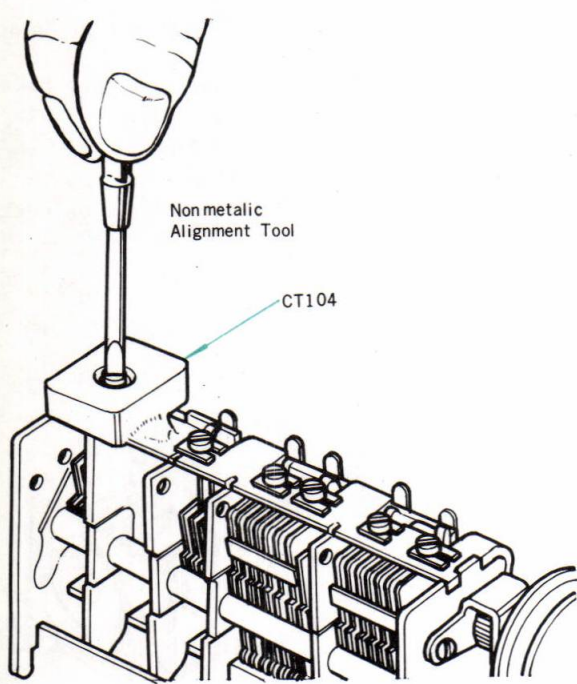

Fig. 3-8 Location of fm trimmer capacitor CT104

3-3. A-M I-F STRIP

Test Equipment Required:

- 455 kHz sweep generator
 Center frequency.....455 kHz
 Sweep width..... ± 35 kHz (variable)
 Output impedanceLess than 300 ohms
- Radiating antenna. See Fig. 3-9.
- Oscilloscope
 Vertical sensitivity10 mV/cm minimum
- Alignment tools.

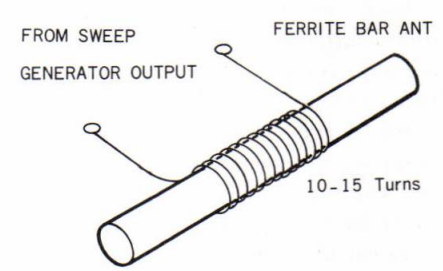

Fig. 3-9 455 kHz radiating antenna

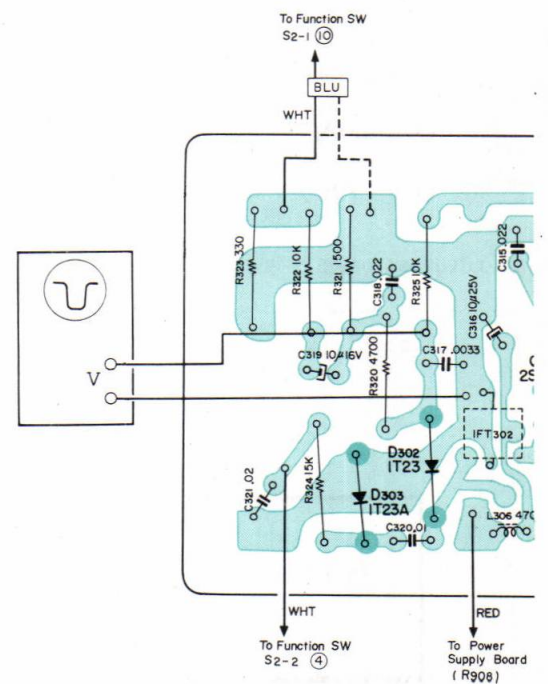

Fig. 3-10 Connection of oscilloscope

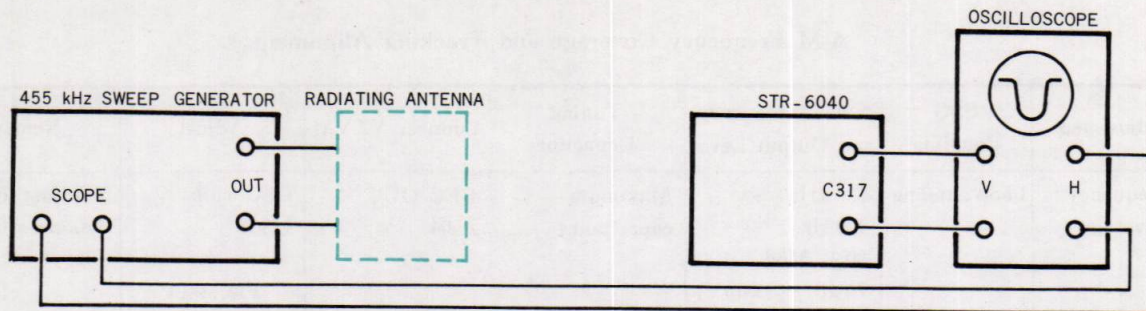

Fig. 3-11 A-m i-f alignment test set-up

Preparation:

1. Remove the top cover and bottom plate as described in Procedure 2-1.
2. Solder a hook-up wire to each end of C317 (0.0033 μ F) from the conductor side of the AM CP/I-F board. Connect the oscilloscope to these wires as shown in Fig. 3-10.
3. Set the receiver's controls as follows:
FUNCTION switchAM
VOLUME controlMinimum

Procedure:

1. With the equipment connected as shown in Fig. 3-11, set the sweep generator output as low as possible and adjust the scope controls to provide a visible indication.
2. Adjust IFT301 to obtain a maximum and symmetrical response, as shown in Fig. 3-12.

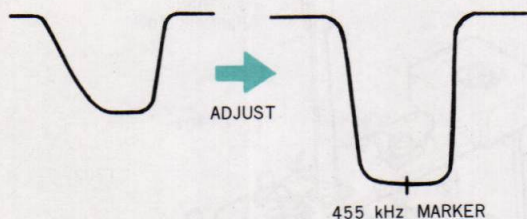

Fig. 3-12 A-m i-f frequency response

3-4. A-M TUNER FREQUENCY COVERAGE AND TRACKING**Test Equipment Required:**

1. Standard a-m signal generator. If such a generator is unavailable, off-the-air signals at each end of the band will suffice.
2. Loop antenna.
3. Ac VTVM.
4. Alignment tools.

Preparation:

1. Remove the top cover, See Procedure 2-1.
2. Set the receiver's controls as follows:
FUNCTION switchAM
VOLUME controlMinimum

Procedure:

With the equipment connected as shown in Fig. 3-13, follow the procedure given in Table 2 on the next page.

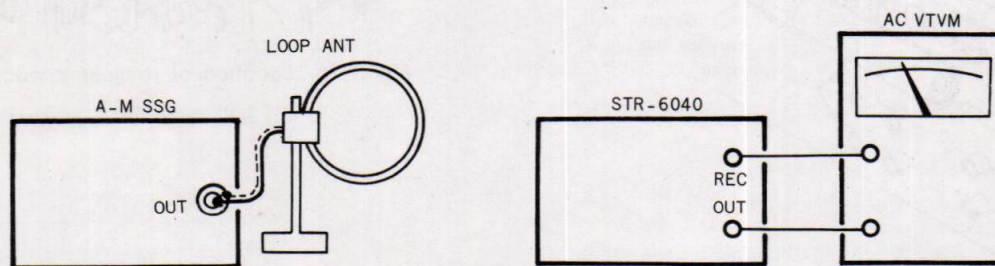

Fig. 3-13 A-m tuner frequency coverage and tracking alignment test set-up

TABLE 2

A-M Frequency Coverage and Tracking Alignment

Adjustment	SSG Coupling	SSG Frequency and Output Level	Tuning Capacitor	Connect VTVM	Adjust	Remarks
Frequency Coverage	Loop antenna	520 kHz 400 Hz 30 % Mod 70 dB/ μ (3000 μ V)	Maximum capacitance	REC OUT J 504	OSC coil L 304 Fig. 3-14	Adjust to obtain maximum reading
		1680 kHz Same as above	Minimum capacitance	Same as above	OSC trimmer CT301 Fig.3-15	Same as above

Note: Repeat the foregoing procedure two or three times until sufficient response is obtained.

Tracking	Loop antenna	SSG Frequency and Output Level	Tuning Capacitor	Connect VTVM	Adjust	Remarks
Tracking	Loop antenna	620 kHz 400 Hz 30 % Mod Output level as low as possible	Tune to 620 kHz signal	REC OUT J 504	Position of bar antenna core L 303 Fig. 3-16	Adjust to obtain maximum reading
		1400 kHz Same as above	Tune to 1400 kHz signal	Same as above	Antenna trimmer CT 302 Fig. 3-15	Same as above

Note: Repeat the foregoing procedure two or three times until sufficient response is obtained.

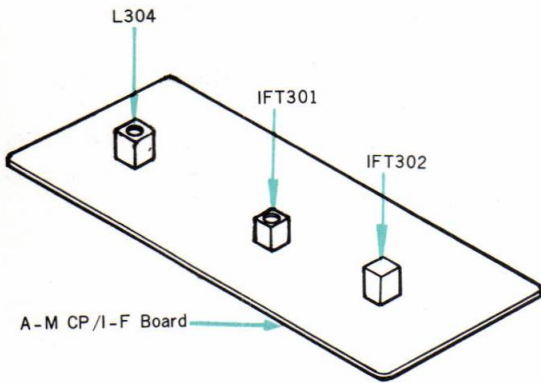

Fig. 3-14 Location of a-m oscillator coil L304

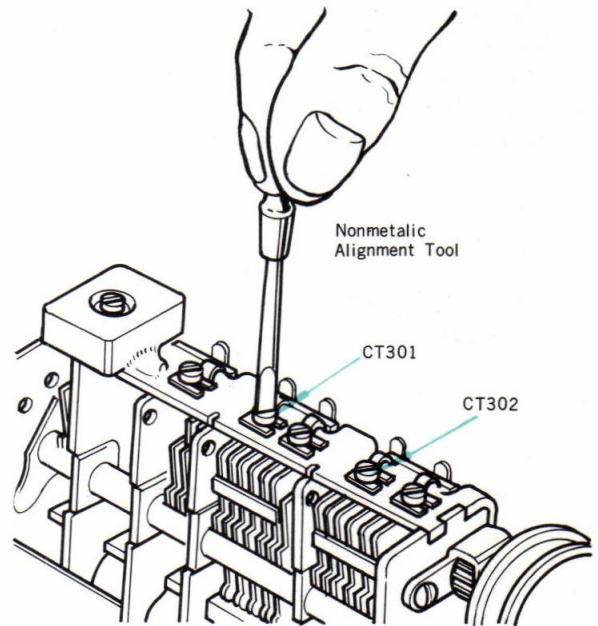

Fig. 3-15 Location of trimmer capacitor CT301 & CT302

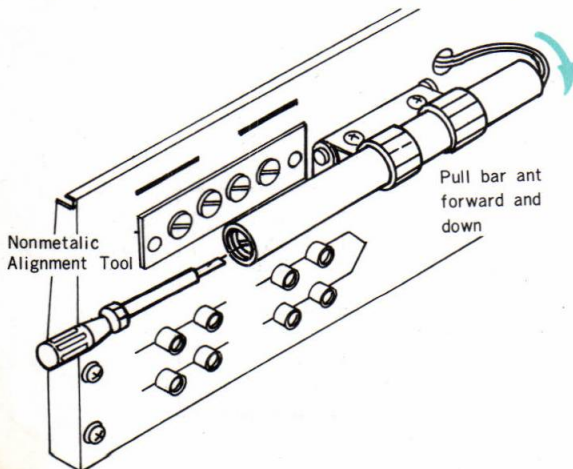

Fig. 3-16 A-m bar antenna core adjustment

SECTION 4

OVERALL ADJUSTMENTS AND TESTS

These "touch-up" adjustments ensure optimum performance.

They also aid in locating troubles.

Test Equipment Required:

1. Standard fm signal generator
2. Multiplex stereo signal generator
3. Audio oscillator
4. Distortion meter with ac VTVM
5. Dummy antenna (See Fig. 3-5.)
6. Oscilloscope
7. Alignment tools

4-1. FM DISCRIMINATOR ADJUSTMENT

Note: This adjustment should be done before performing any other adjustments. Then follow Procedure 4-2 "FM MONAURAL DISTORTION" described on page 20. In case the discriminator transformer is replaced, first follow the procedure described in Procedure 3-1 "FM DISCRIMINATOR ADJUSTMENT" described on page 14.

Preparation:

1. Unsolder the grounded leads of resistors R247 and R248 on the I-F amplifier and discriminator board. Then, connect a null meter (center zero) or dc voltmeter between the junction of R247 and R248, and the ground foil, as shown in Fig. 4-1.
2. Set the receiver's controls as follows.
 FUNCTION switchFM MONO
 VOLUME controlMinimum

Procedure:

1. With the equipment connected as shown in Fig. 4-2, make sure that the null meter shows a center-scale reading under no signal conditions. If it does not, turn the top core of T201 (discriminator transformer) slightly to obtain zero indication on the meter. In performing this step, watch the oscilloscope and see that it displays only noise.
2. Repeat the above step two or three times while changing the setting of the TUNING control.
3. Tune the receiver to the 98 MHz 400 Hz 100% Mod. 1000 μ V signal. Make certain that the null meter gives a zero reading when tuning or completely detuning the receiver.

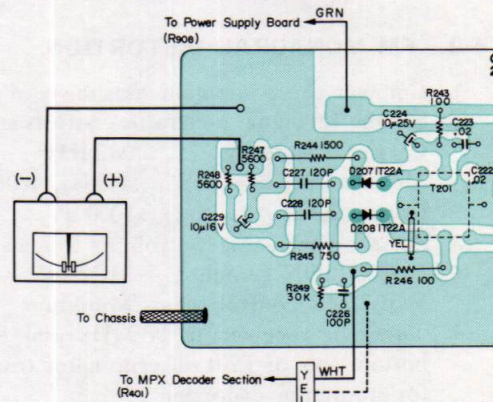

Fig. 4-1 Connection of null meter

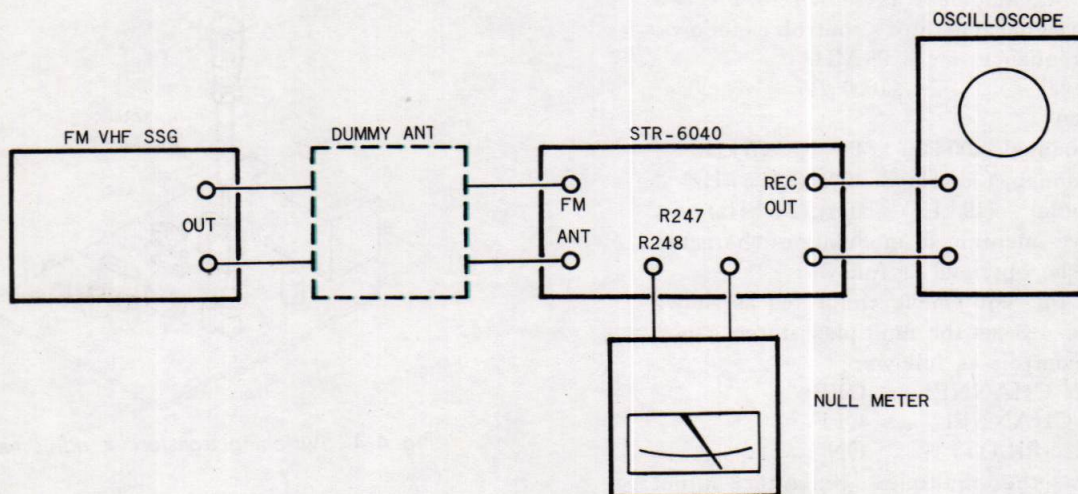

Fig. 4-2 FM discriminator adjustment test set-up

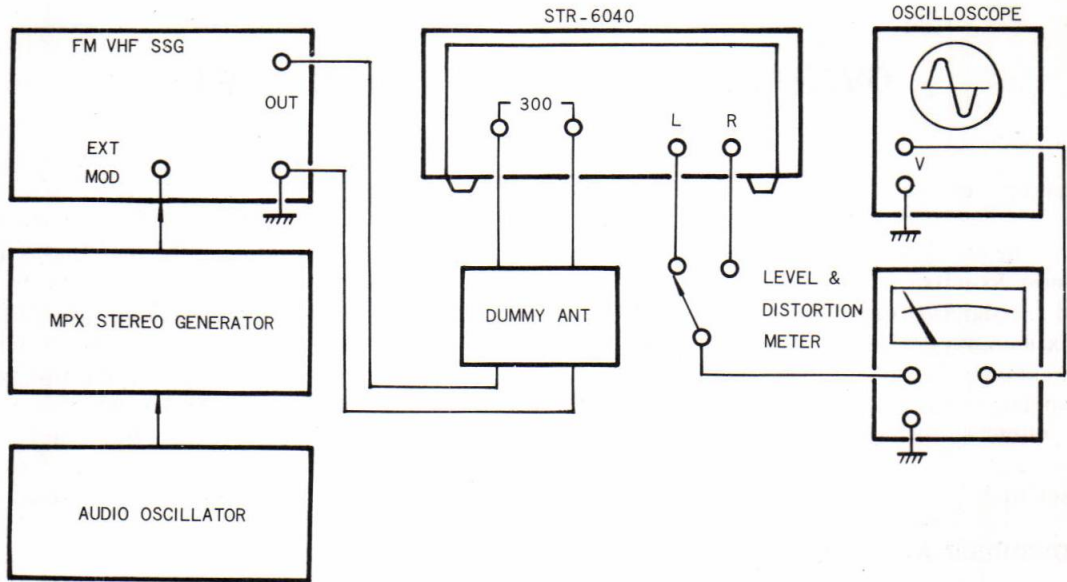

Fig. 4-3 Overall adjustment test set-up

4-2. FM MONAURAL DISTORTION

1. Connect the equipment as shown in Fig. 4-3.
2. Set the fm signal generator controls as follows:
 Carrier frequency98 MHz
 Modulation.....400 Hz, 100%
 Output level1000 μ V
3. Set the receiver's controls as follows:
 FUNCTION switchMONO
 VOLUME controlMinimum
4. Tune the receiver to 98 MHz and adjust the bottom core of T201 (discriminator transformer) for minimum distortion.

4-3. FM STEREO DISTORTION

1. Connect the equipment as shown in Fig. 4-3, set the fm signal generator's controls as follows:
 Carrier frequency98 MHz
 Output level1000 μ V
 Modulation:
 Main channel (400 Hz) ...45% (33.75 kHz)
 Sub channel (38 kHz) ...45% (33.75 kHz)
 Pilot signal (19 kHz) ...10% (7.5 kHz)

The above mentioned modulation characteristics can be obtained as follows:

- (a) With the equipment connected as shown in Fig. 4-3, set the multiplex stereo generator controls as follows:
 MAIN CHANNEL.....OFF
 SUB CHANNEL.....OFF
 19 kHz (PILOT)ON
- (b) Adjust the multiplex generator output level to obtain a 7.5 kHz deviation on the FM SSG modulation indicator.

- (c) Reset the generator controls as follows:
 MAIN CHANNEL.....ON
 SUB CHANNEL.....OFF
 19 kHz (PILOT)OFF
 - (d) Adjust the audio oscillator output control to obtain a 33.75 kHz deviation on the FM SSG modulation indicator.
 - (e) Set all controls to the ON position.
2. Check for distortion on each channel. Adjust the core of T401 (switching transformer) on the receiver's multiplex decoder board as shown in Fig. 4-4 to obtain minimum distortion.

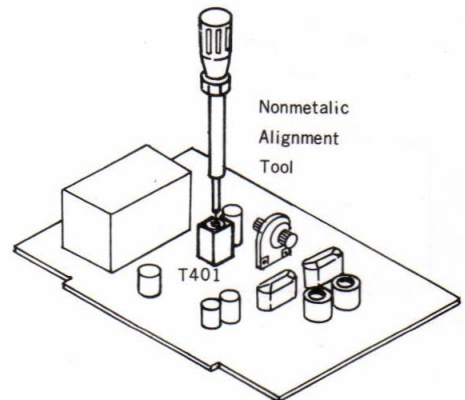

Fig. 4-4 Switching transformer adjustment

4-4. CHANNEL SEPARATION

1. With the equipment connected as shown in Fig. 4-3, set the signal generator and receiver's controls to the positions described in the Procedure 4-2 "FM STEREO DISTORTION."
2. Check the channel separation as follows:
Record the output level of the left channel when the multiplex generator input selector is set to the left channel. Switch the input selector to the right channel, and read the residual signal level in the left channel. The output-level to residual-level ratio represents the channel separation.
Adjust RV504 (1 k-B) (separation adj.) on the multiplex and preamplifier board for minimum residual level.
Check the right channel separation. Usually, about an 8 to 9 dB difference in channel separation exists. Readjust RV504 for minimum difference between left and right separation.

Note: Remember that the output level changes according to the setting of RV504.

4-5. DIAL POINTER CALIBRATION

1. Connect the signal generator to the antenna terminals of the receiver using a dummy antenna. See Fig. 4-3.
2. Set the generator to 98 MHz (crystal calibrated), 400 Hz 100% modulation. Set the output level to 10 μ V.
3. Tune the receiver precisely to the 98 MHz signal.
4. Set the dial pointer to the 98 MHz marking on the dial scale.

4-6. POWER AMPLIFIER

This adjustment should be made after replacing any of the power amplifier transistors.

Note: To simplify the following procedure only the left channel and related adjustments are described. The right channel adjustment is identical except for component reference numbers (See the schematic diagram on page 40.)

Preparation:

Set the receiver's controls as follows:

TONE controls.....Flat (center position)
MODE switchSTEREO
MONITOR switchTAPE
VOLUME controlMinimum

Dc Bias Adjustment

CAUTION

Serious troubles, such as thermal runaway of power transistors, will result if this adjustment is set improperly. Furthermore, to avoid ac-

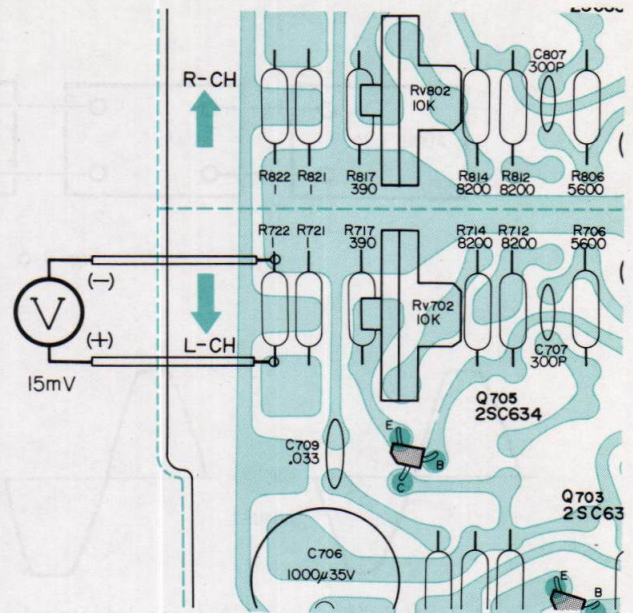

Fig. 4-5 Connection of dc volt meter across R722

cidental power-transistor damage, increase the ac line voltage gradually, using the variable transformer, while checking the voltage across emitter resistor R722 (1.0 ohm). Check to see that the reading does not exceed 15 mV. See Fig. 4-5.

1. Connect a dc voltmeter across emitter resistor R722 (1.0 ohm) as shown in Fig. 4-5.
2. Turn on the POWER switch; then increase the line voltage gradually up to the rated value.
3. Adjust RV702 (10 k ohm-B) to obtain a 15 mV reading on the meter.

Ac Balance Adjustment

Note: Serious deficiencies in harmonic distortion at high levels will result if this adjustment is set improperly.

1. With the equipment connected as shown in Fig. 4-6 and the power switch in the ON position, feed a 1 kHz, 0 dB signal to the TAPE IN terminal.
2. While watching the waveform on the oscilloscope, alternately turn the VOLUME control (RV501) and adjust RV701. Adjust RV701 (10 k Ω -B) so that the positive and negative peaks of the output waveform are simultaneously clipped (as shown in Fig. 4-7) when increasing the VOLUME control beyond the point that causes distortion.

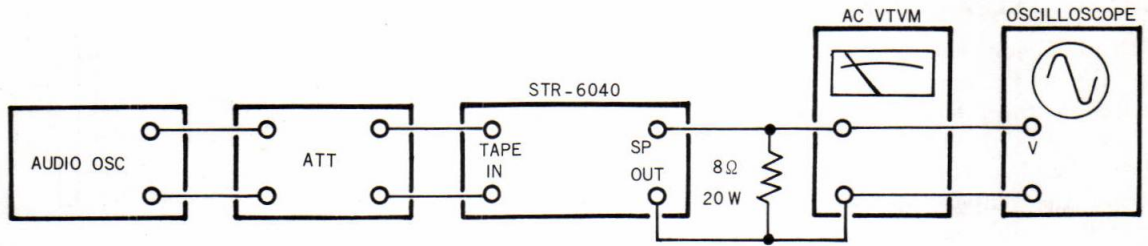

Fig. 4-6 Ac balance adjustment test set-up

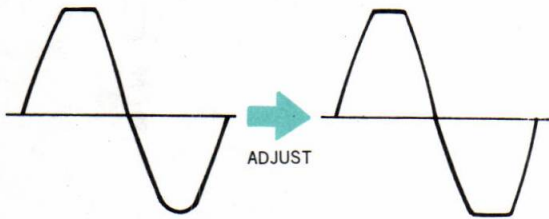
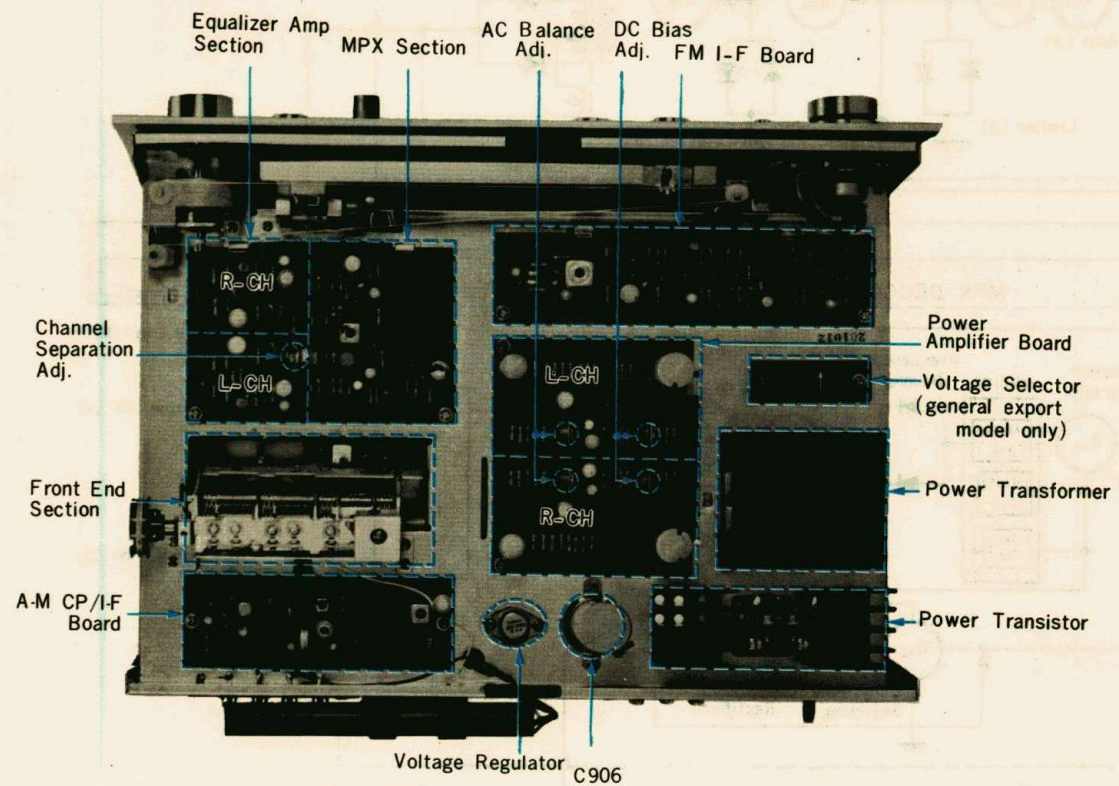

Fig. 4-7 Waveforms at ac balance adjustment

CHASSIS LAYOUT

Top View



Bottom View

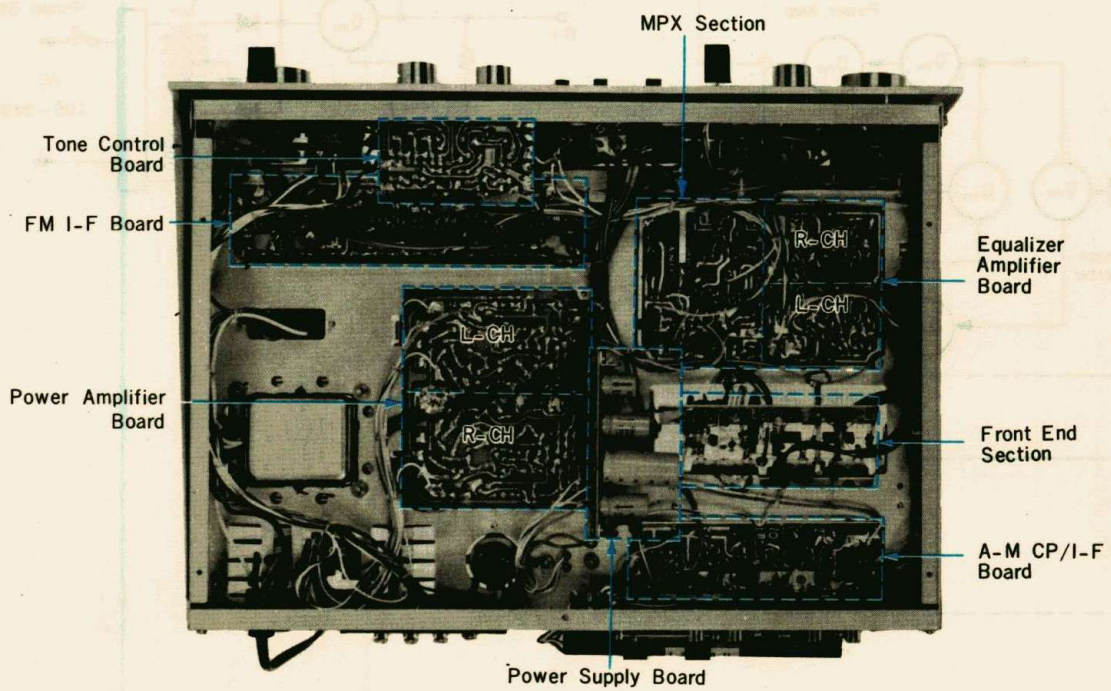

LEVEL DIAGRAM

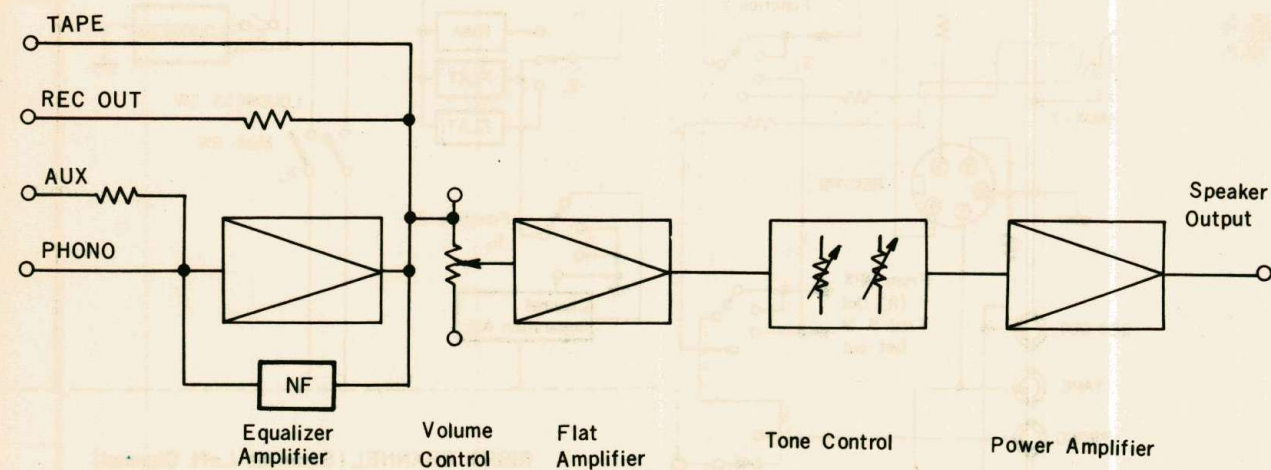
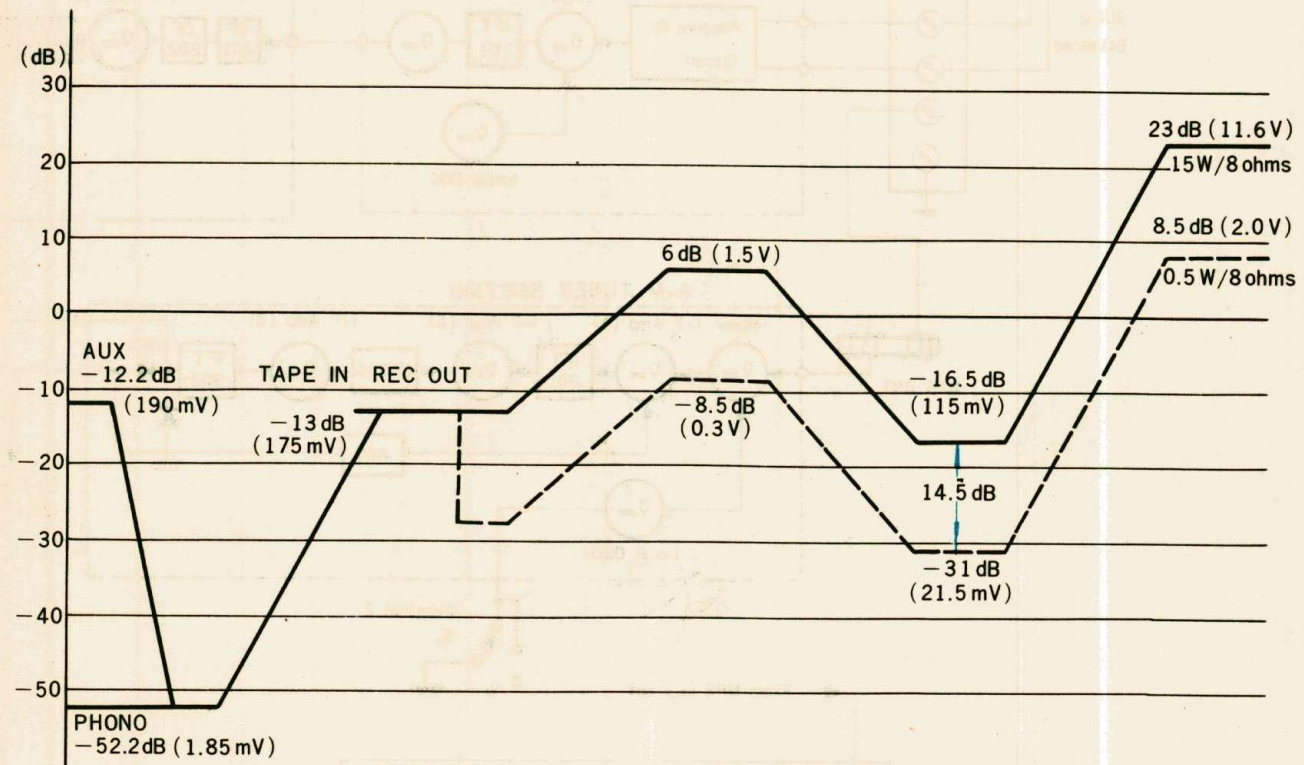

BLOCK DIAGRAM

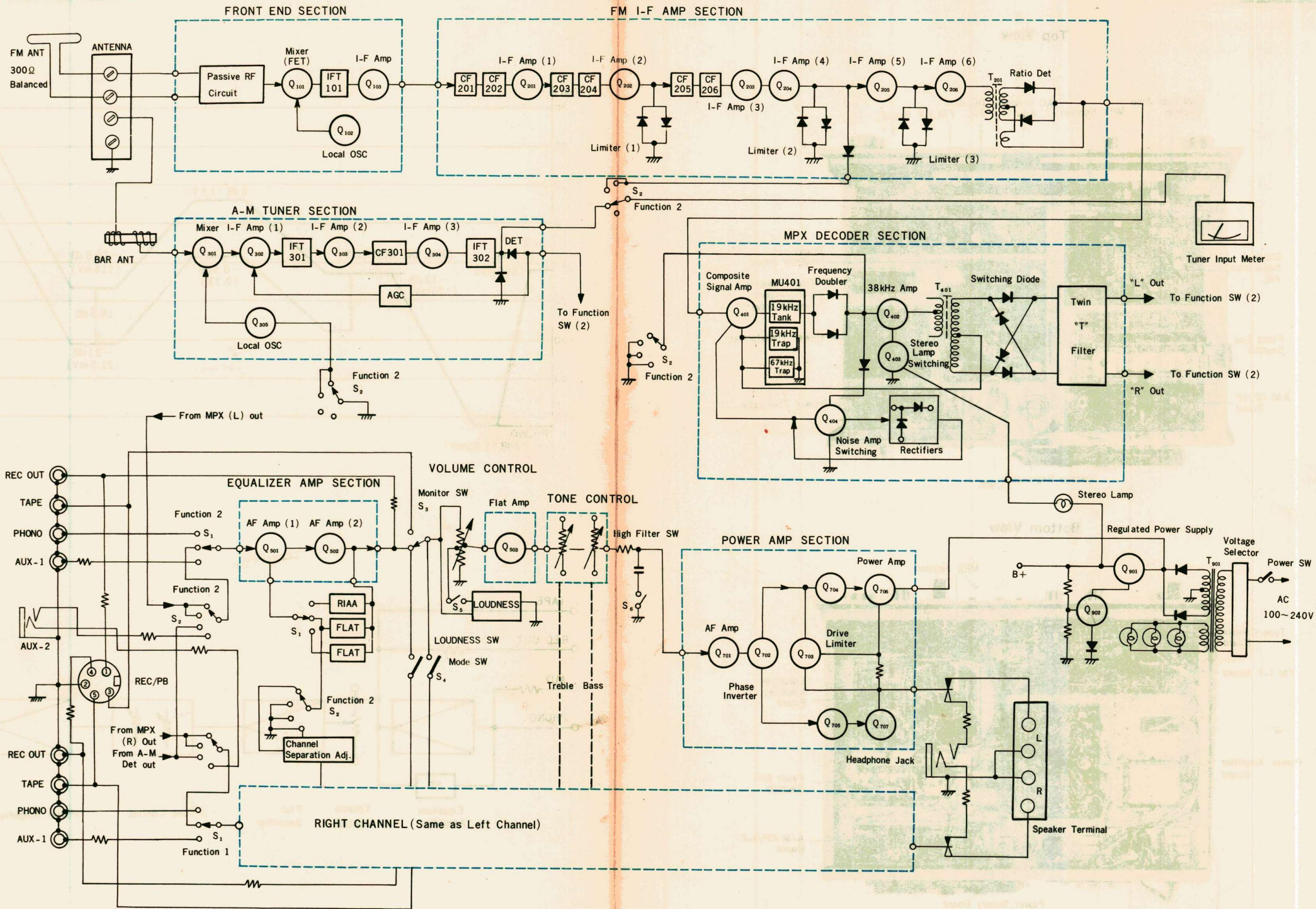

MOUNTING DIAGRAM

A-M CP / I-F Amplifier Board

- Conductor Side -

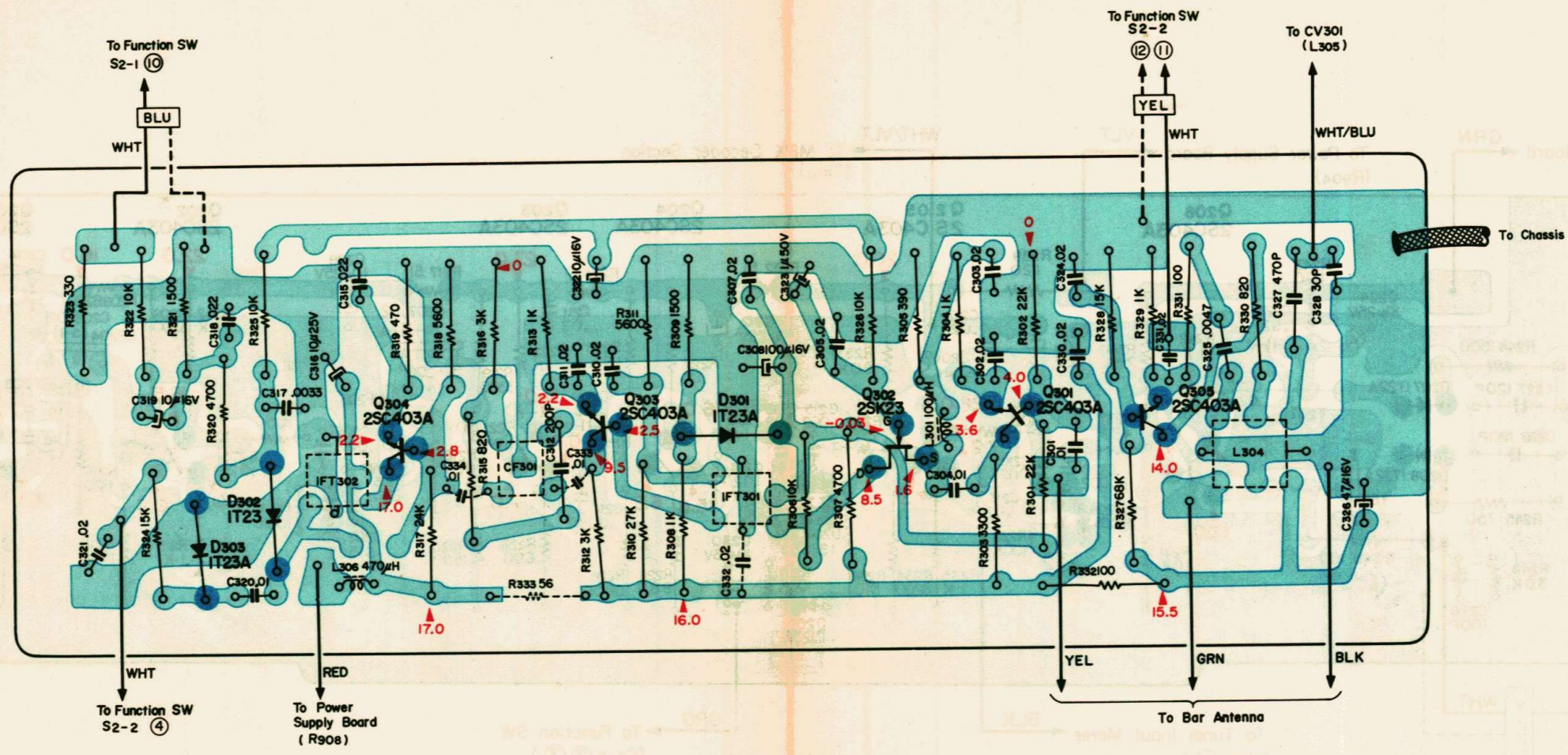

- Component Side -

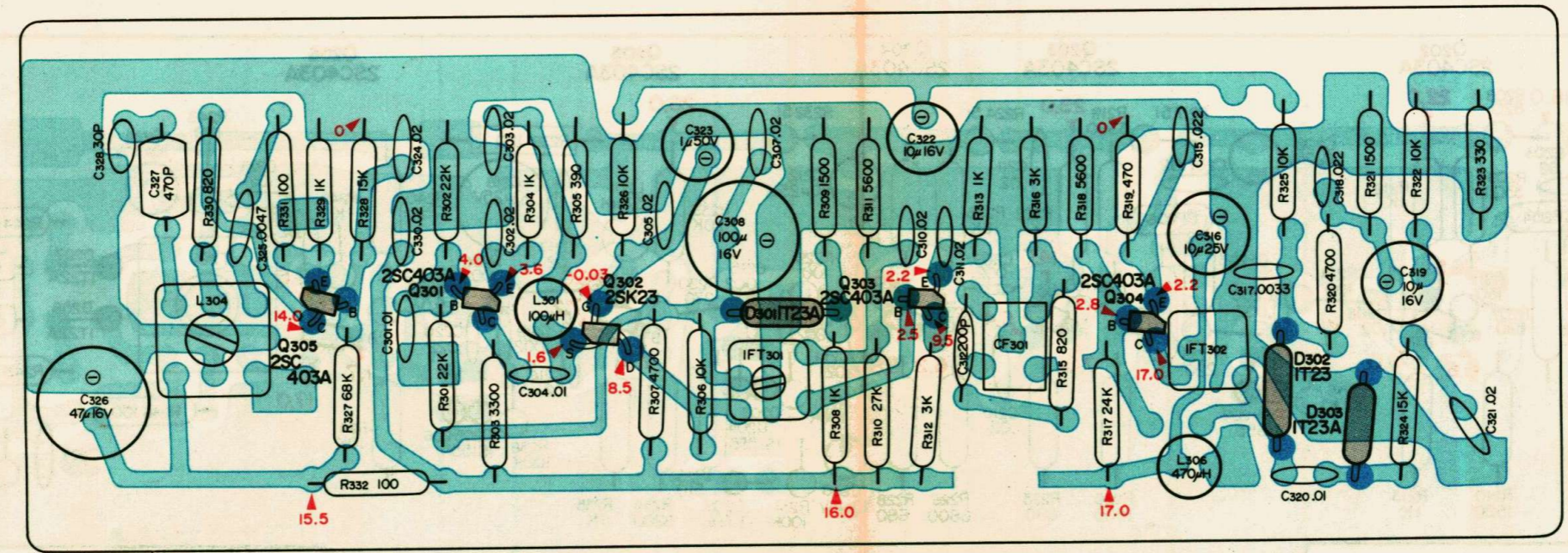

MOUNTING DIAGRAM

FM I-F Amplifier Board

— Conductor Side —

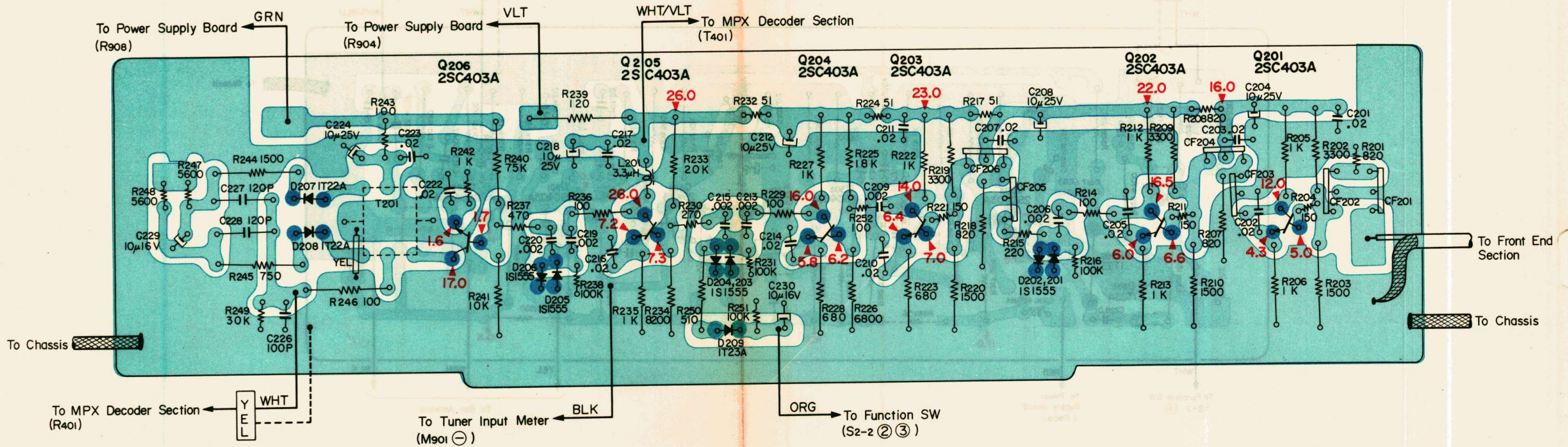

— Component Side —

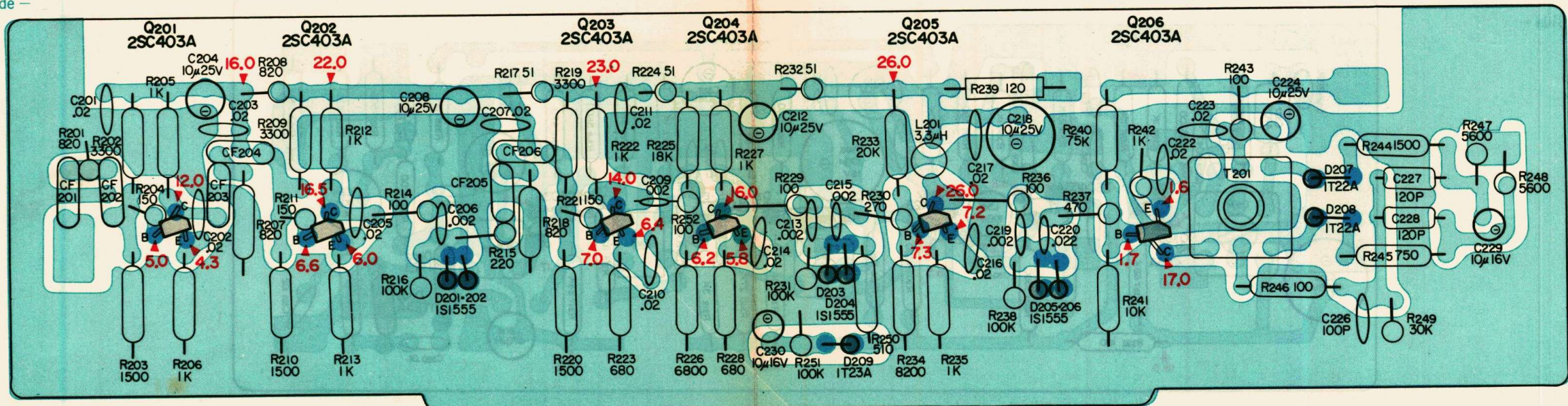

MOUNTING DIAGRAM

FM Front-end Section

— Conductor Side —

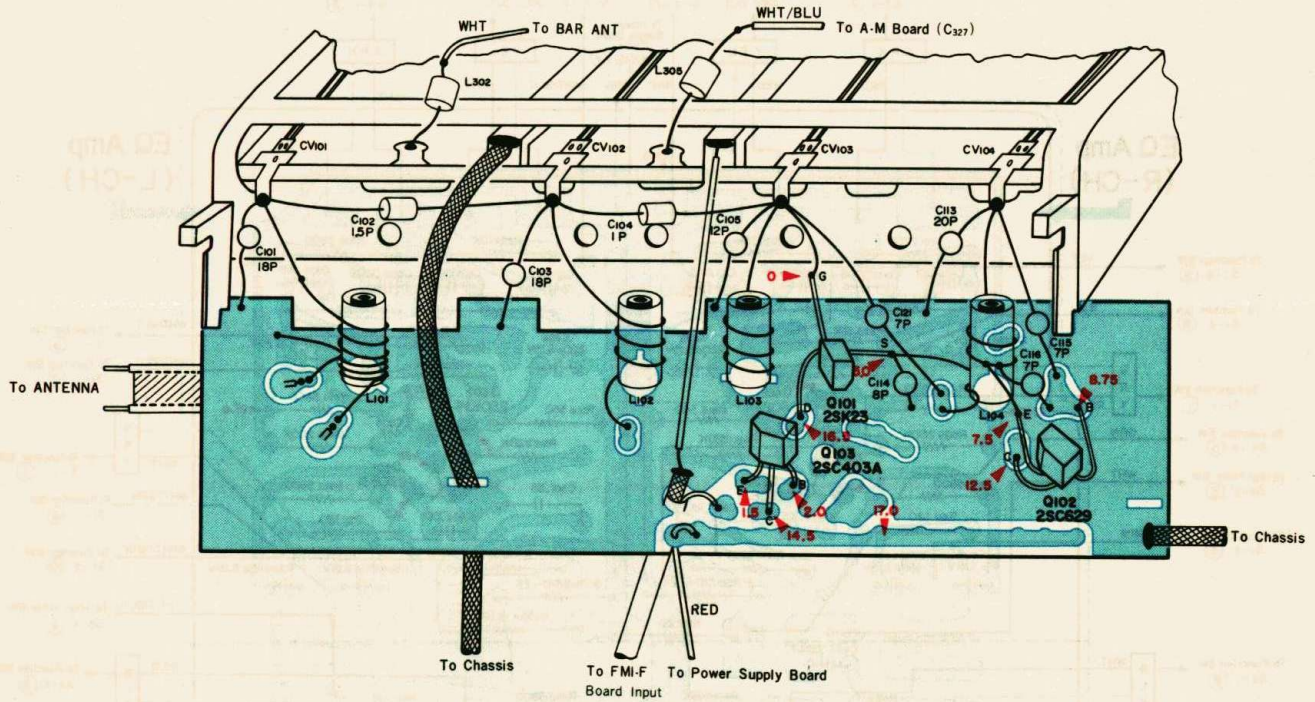

— Component Side —

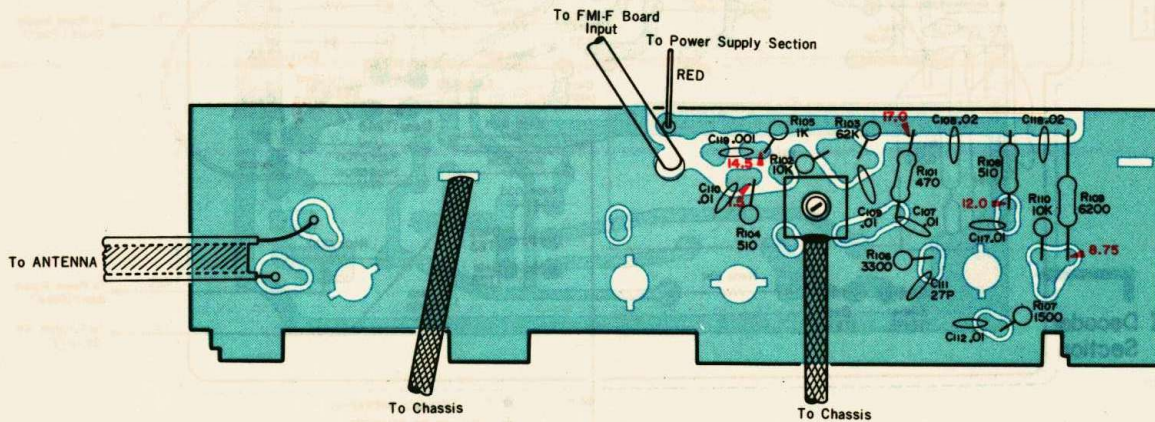

MOUNTING DIAGRAM

Multiplex Decoder and Equalizer Amplifier Board

— Conductor Side —

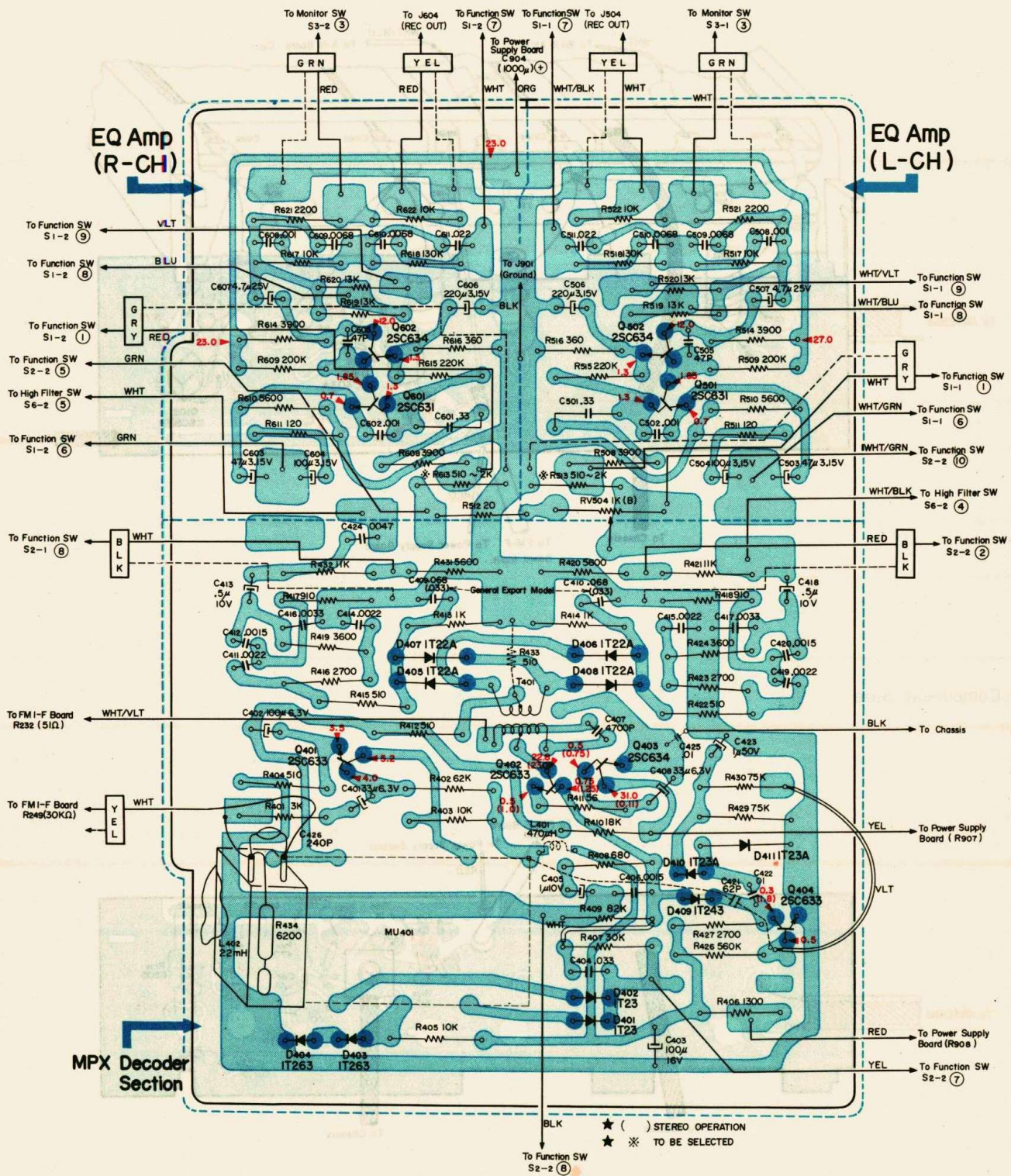

MOUNTING DIAGRAM

Multiplex Decoder and Equalizer Amplifier Board

- Component Side -

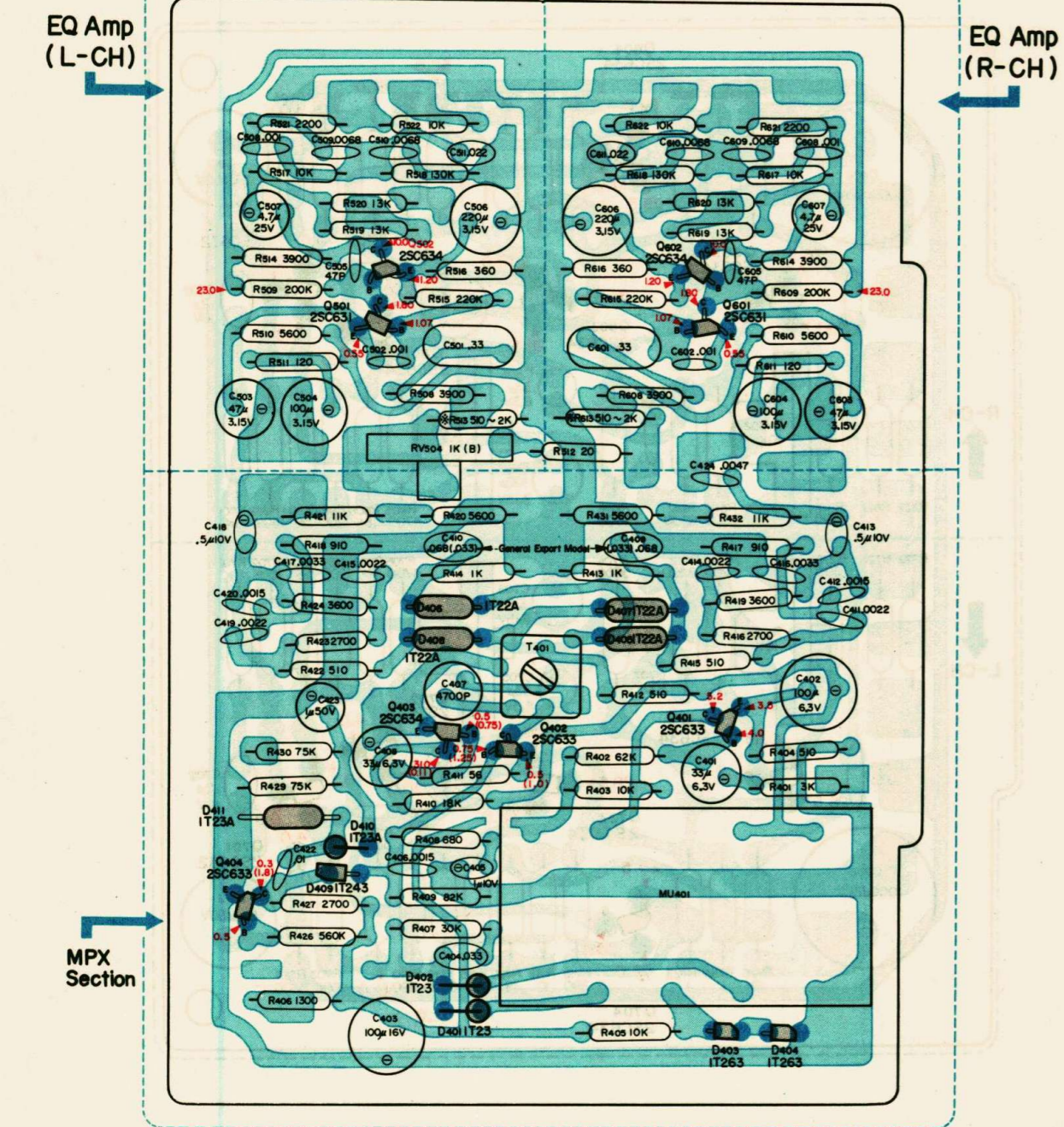

() STEREO OPERATION
 ★ * TO BE SELECTED

SCHEMATIC DIAGRAM

Tuner Section

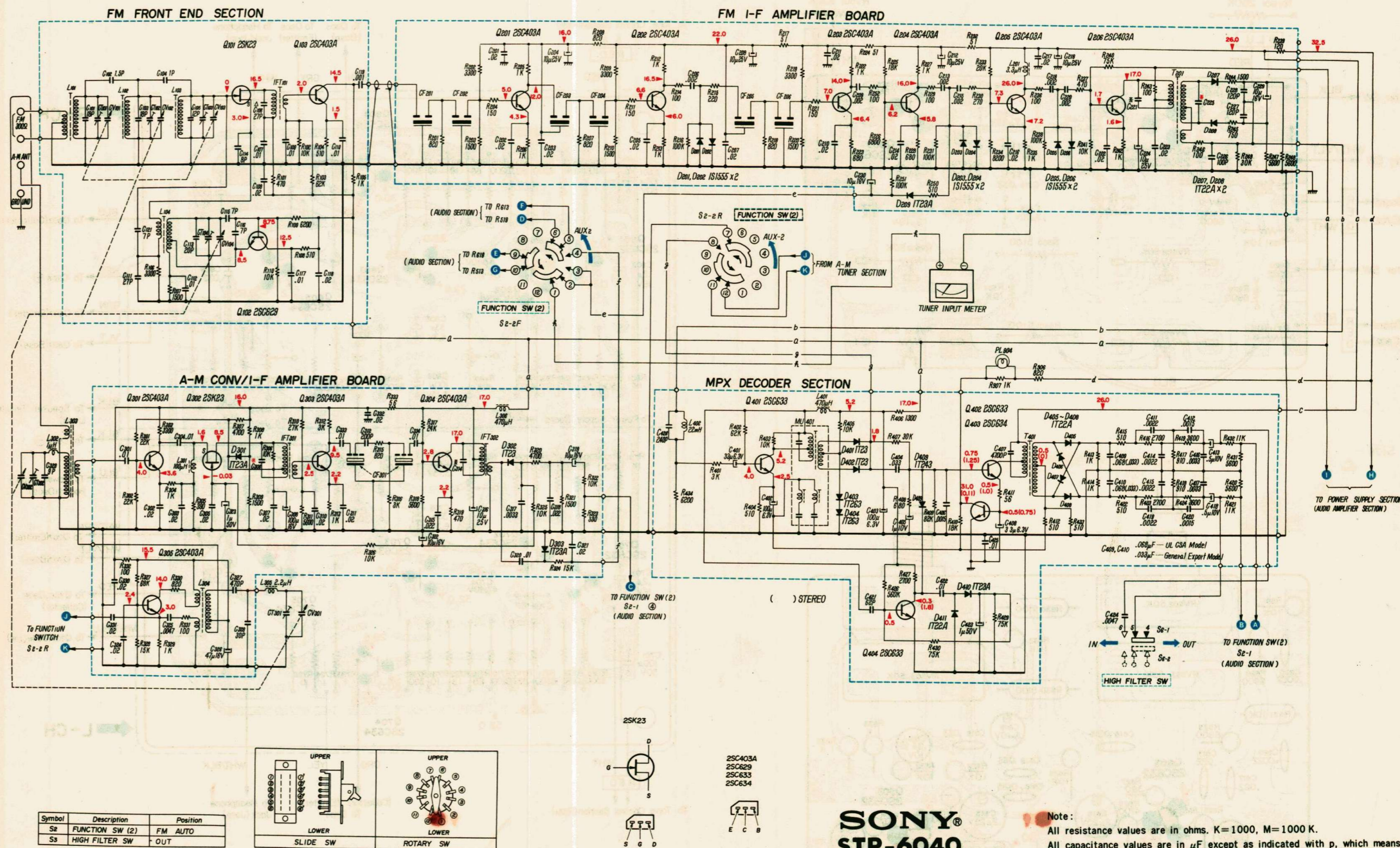

Symbol	Description	Position
S2	FUNCTION SW (2)	FM AUTO
S3	HIGH FILTER SW	OUT

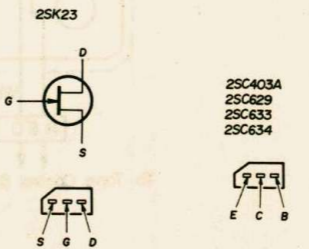
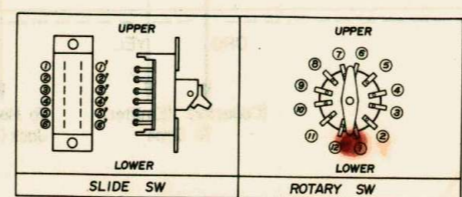

SONY
STR-6040
 © 1969

Note:
 All resistance values are in ohms. K=1000, M=1000 K.
 All capacitance values are in μ F except as indicated with p, which means μ F.
 All voltages are dc measured with a VOM (DC 20 kohms/volt) under no signal condition.
 Resistors marked * should be selected.

MOUNTING DIAGRAM

Tone Control and Flat Amplifier Board

- Conductor Side -

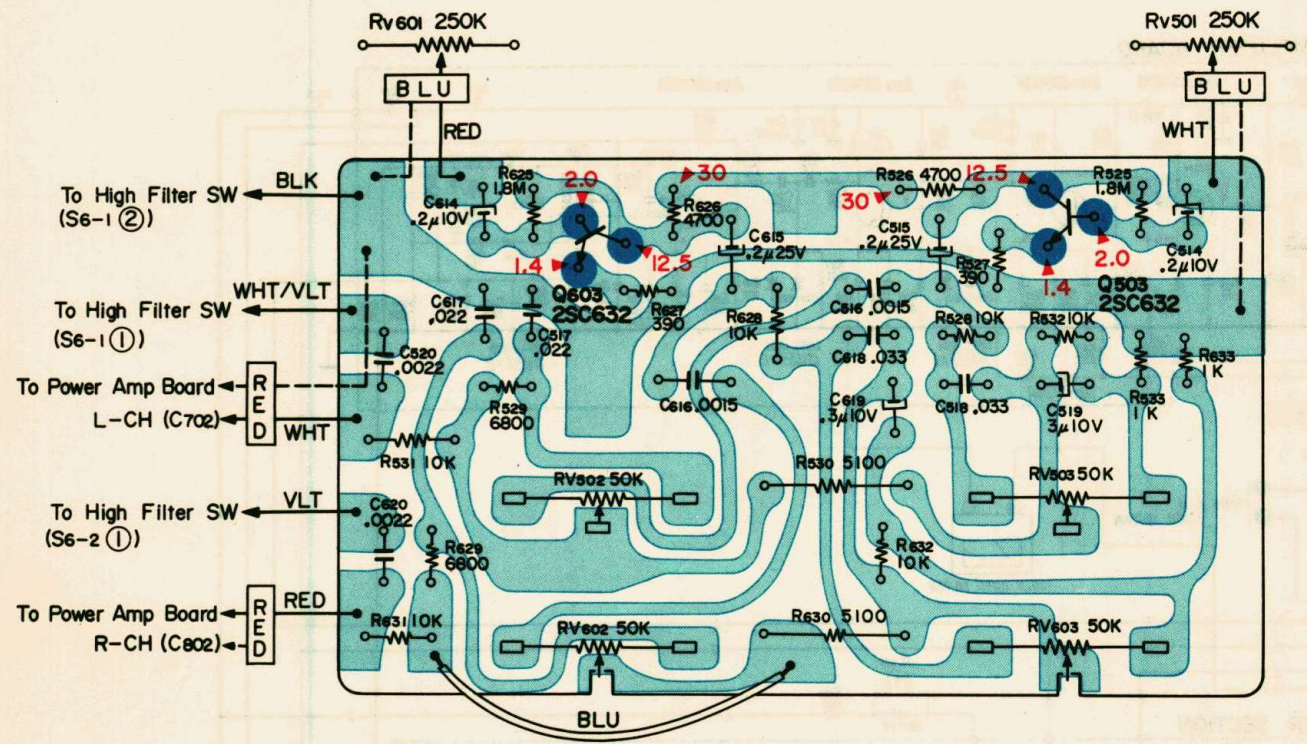

- Component Side -

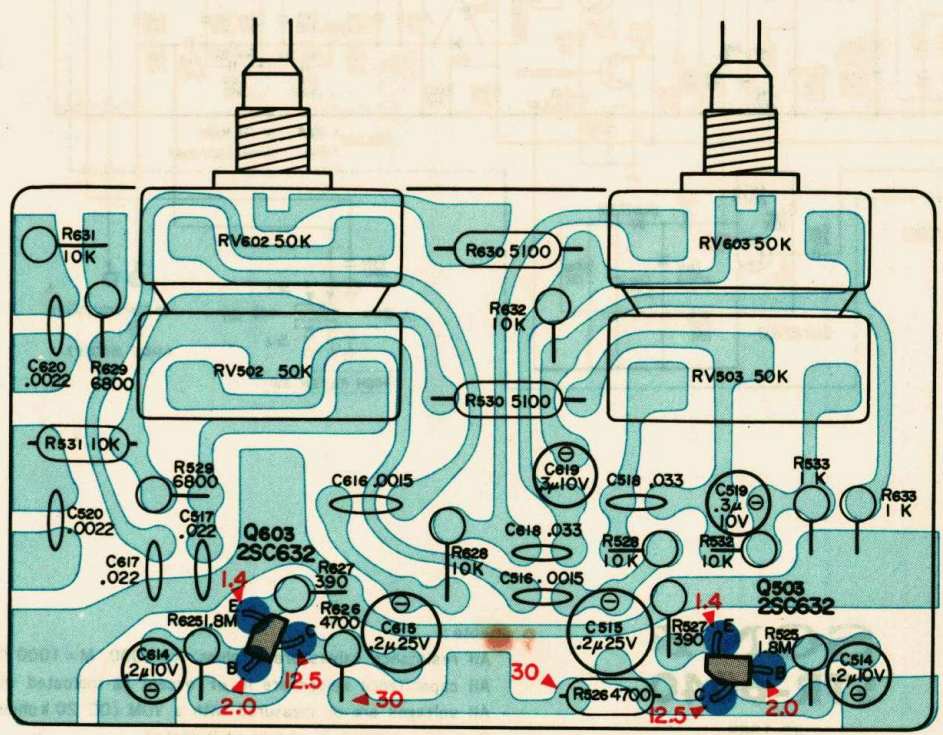

MOUNTING DIAGRAM

Power Supply Board

— Conductor Side —

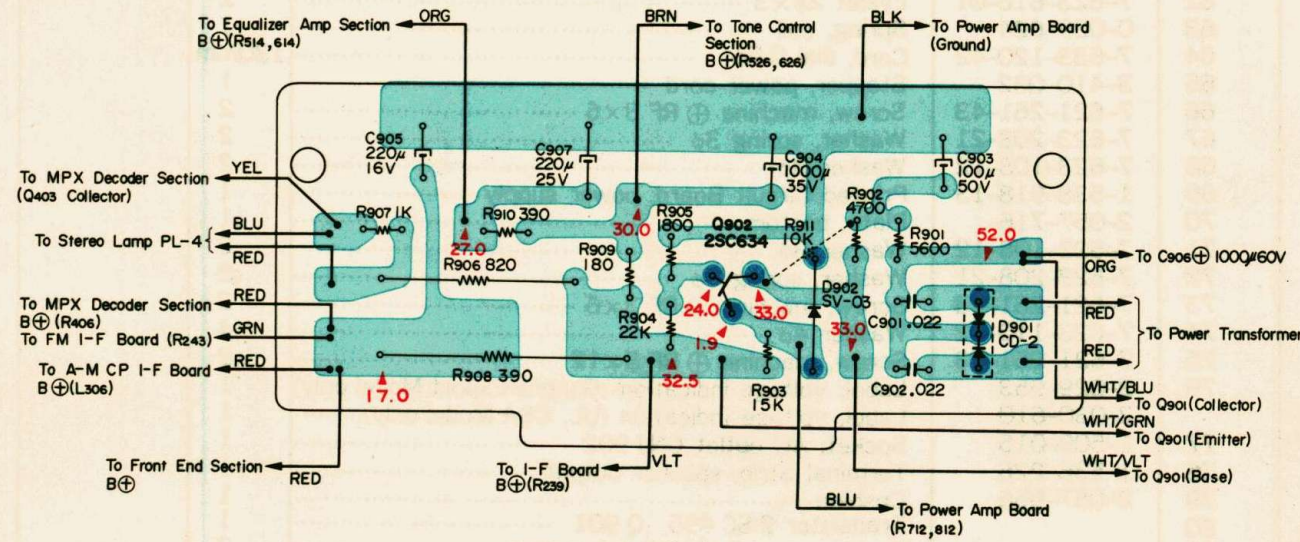

— Component Side —

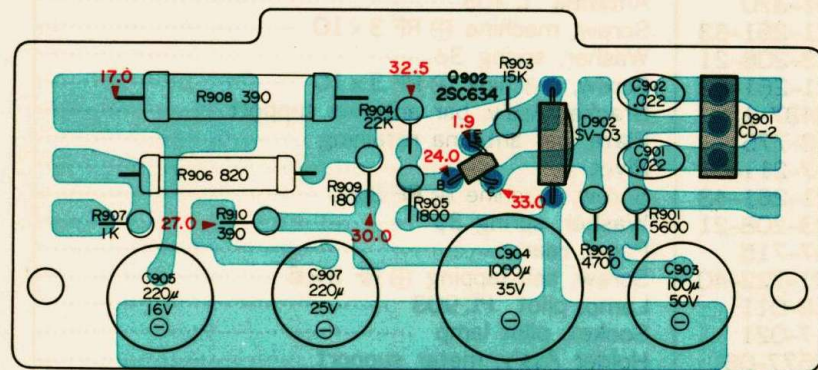

SCHEMATIC DIAGRAM

Audio Amplifier Section

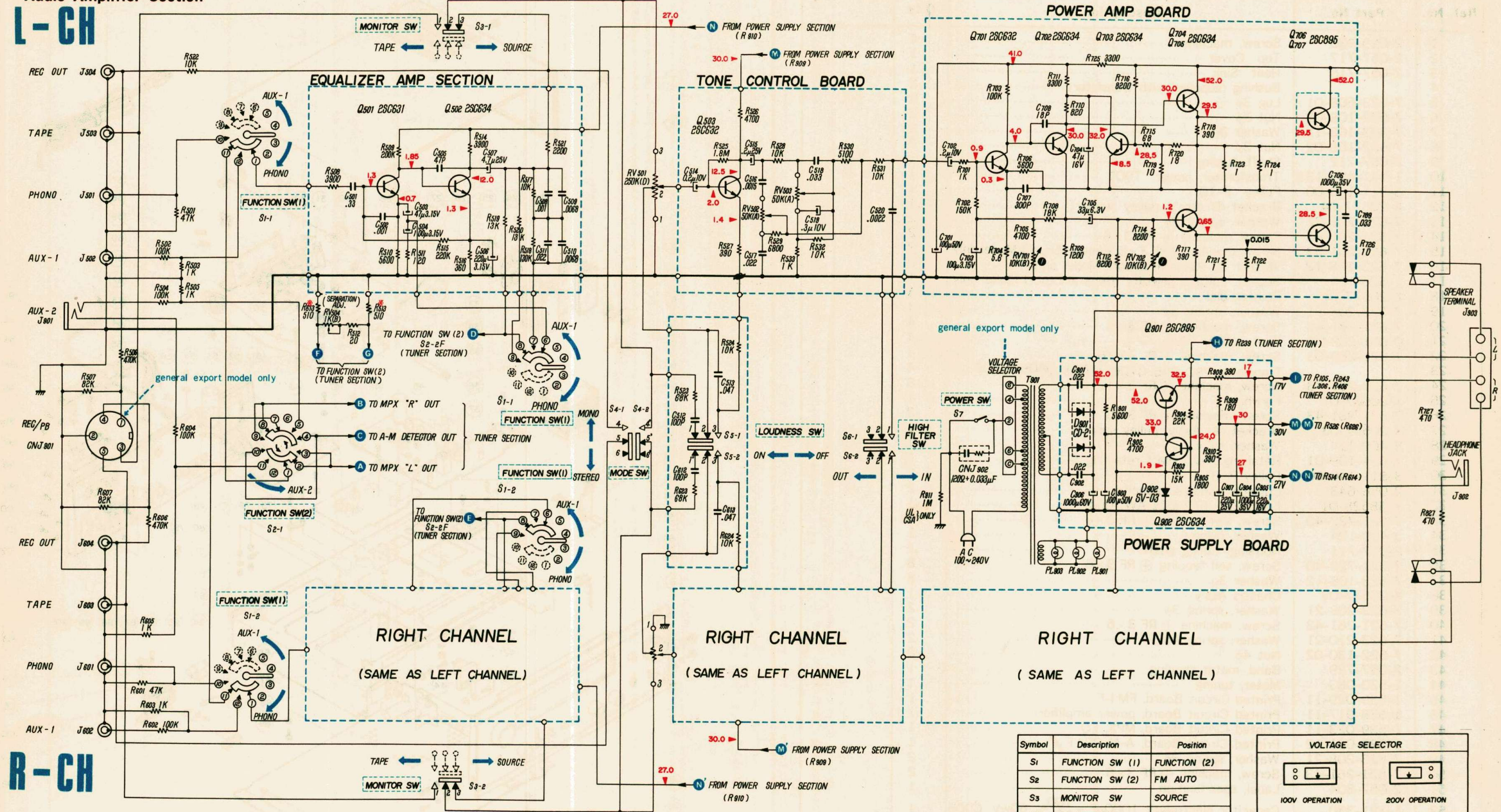

R-CH

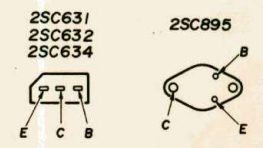
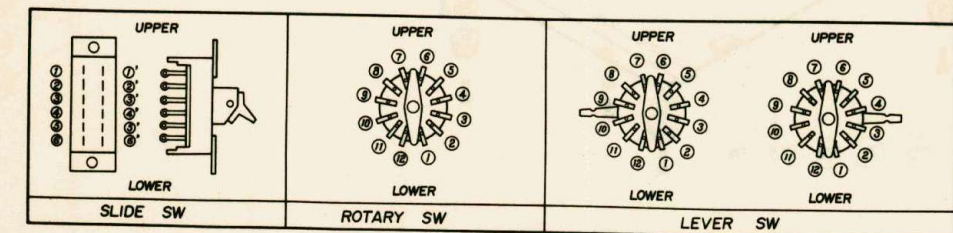

Symbol	Description	Position
S1	FUNCTION SW (1)	FUNCTION (2)
S2	FUNCTION SW (2)	FM AUTO
S3	MONITOR SW	SOURCE
S4	MODE SW	STEREO
S5	LOUDNESS SW	ON
S6	HIGH FILTER SW	OFF
S7	POWER SW	OFF

VOLTAGE SELECTOR	
100V OPERATION	200V OPERATION
120V OPERATION	240V OPERATION

Note:
 All resistance values are in ohms. K=1000, M=1000K.
 All capacitance values are in μ F except as indicated with p, which means μ F.
 All voltages are dc measured with a VOM (DC 20 kohms/volt) under no signal condition.
 Resistors marked * should be selected.

SONY STR-6040

© 1969

REPLACEMENT PARTS LIST

Ref. No.	Part No.	Description	Q'ty
1	2-029-930	Screw, machine	4
2	2-057-717	Top Cover	1
3	2-057-718	Heat Sink	1
4		Bushing (supplied with transistor)	2
5	7-623-508-01	Lug 3φ	2
6	7-622-108-02	Nut 3φ	2
7	7-623-108-12	Washer 3φ	2
8	7-622-108-02	Nut 3φ	2
9	2-057-712	Shaft, tuning	1
10	1-441-453-13S	Transformer, power T901	1
11	3-811-140-00	Pulley P-10	1
12	X-20577-04	Bracket (B) Ass'y, pulley support	1
13	7-623-208-22	Washer, spring 3φ	2
14	7-621-261-43	Screw, machine ⊕ RF 3×6	2
15	7-621-261-53	Screw, machine ⊕ RF 3×8 (General Export Model only)	2
16	7-623-108-12	Washer 3φ (General Export Model only)	2
17	1-526-165	Socket, voltage selector (General Export Model only)	1
18	X-20577-05	Pointer, dial	1
19	7-623-208-21	Washer, spring 3φ	4
20	7-621-261-43	Screw, machine ⊕ RF 3×6	4
21	0-051-263-04	Foot, rubber	4
22	7-621-269-03	Screw, machine ⊕ RF 4×16	4
23		Transistor 2SC 895 Q706, Q709, Q806, Q809	4
24	7-621-261-73	Screw, machine ⊕ RF 3×12	8
25	X-20577-07	Flywheel	1
26	7-621-261-43	Screw, machine ⊕ RF 3×6	2
27	X-20577-03	Bracket (A) Ass'y, pulley support	1
28	3-409-124	Washer, nylon	1
29	7-624-109-01	Retaining Ring, shaft retaining E-5	1
30	3-811-140-00	Pulley P-10	2
31	2-056-643	Cushion, variable capacitor	2
32	Y-38528-01	Front End (FAF-O11 AW) Unit	1
33	7-621-722-40	Screw, self-tapping ⊕ RF 3×6	1
34	3-409-124	Washer, nylon	1
35	2-057-711	Housing, tuning shaft	1
36	7-621-722-40	Screw, self-tapping ⊕ RF 3×6	8
37	7-623-108-12	Washer 3φ	8
38	X-20577-02	Chassis Ass'y	1
39	7-623-208-21	Washer, spring 3φ	2
40	7-621-261-43	Screw, machine ⊕ RF 3×6	2
41	7-623-210-21	Washer, spring 4φ	2
42	7-622-130-02	Nut 4φ	2
43	2-057-729	Band, meter shading	1
44	1-520-083	Meter, tuning	1
45	1-539-029-11	Printed Circuit Board, FM I-F	1
46	1-538-917-11	Printed Circuit Board, power amplifier	1
47	1-539-023-11	Printed Circuit Board, MPX, EQ	1
48	1-539-021-12	Printed Circuit Board, A-M CP/I-F	1
49	7-623-208-21	Washer, spring 3φ	2
50	7-621-261-43	Screw, machine ⊕ RF 3×6	2
51	2-057-804	Label, specification	1
52	1-121-330	Capacitor, electrolytic 1000μF ±10% 60WV C906	1
53	3-811-819-03	Label, FCC	1
54	7-621-722-40	Screw, self-tapping ⊕ RF 3×6	2
55	2-047-211-06	Rivet	2
56	7-623-108-12	Washer 3φ	2
57	7-621-722-40	Screw, self-tapping ⊕ RF 3×6	2
58	2-056-635	Bracket, tuning capacitor	1
59	7-621-722-40	Screw, self-tapping ⊕ RF 3×6	4

EXPLODED VIEW 1

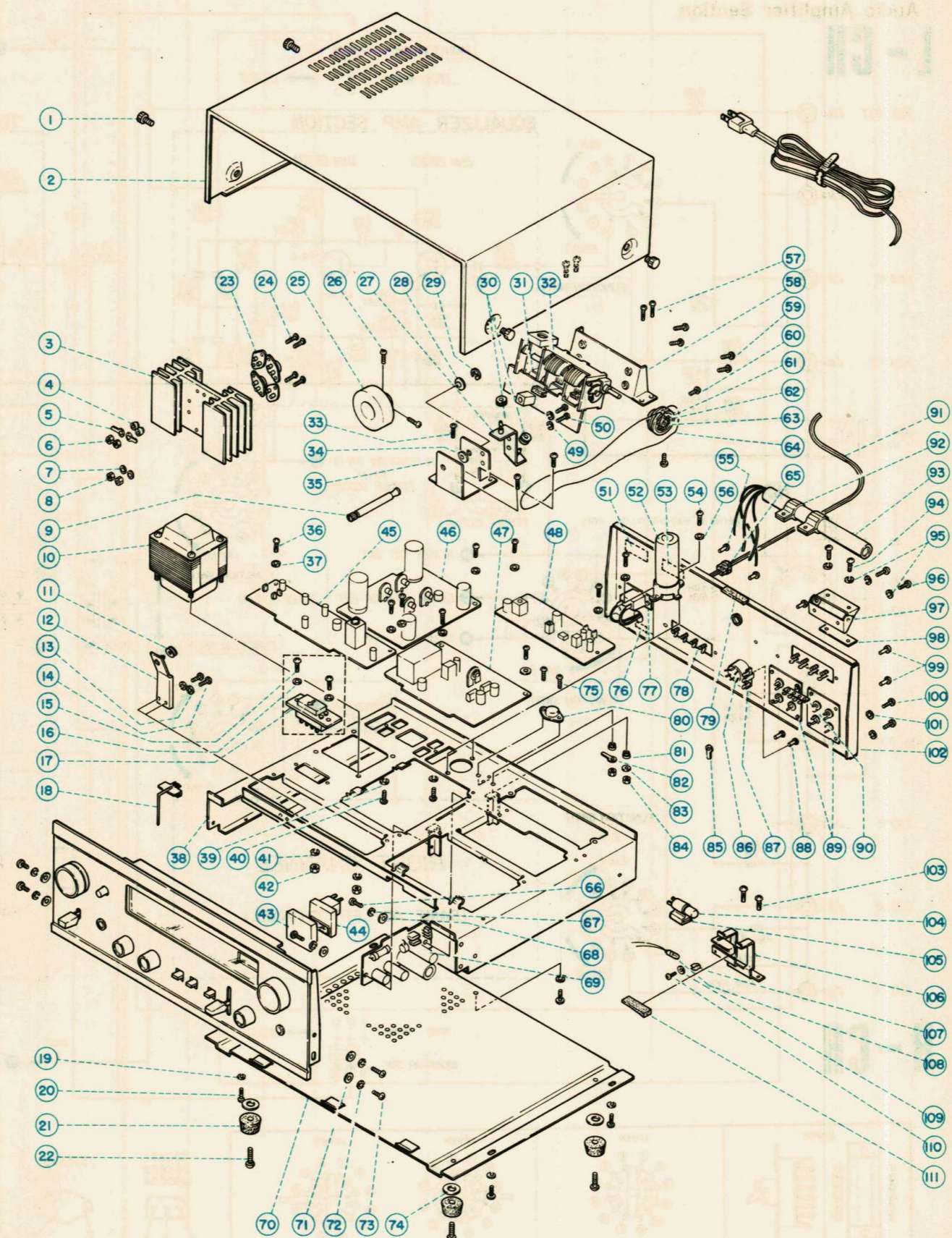

REPLACEMENT PARTS LIST

Ref. No.	Part No.	Description	Q'ty
60	7-621-261-43	Screw, machine ⊕ RF 3×6	2
61	2-057-719	Drum, tuning capacitor	1
62	7-623-616-01	Eyelet 2φ×3	2
63	0-029-624	Spring, coil	1
64	7-633-120-42	Cord, dial 0.5φ	130mm
65	3-410-032	Stopper, power cord	1
66	7-621-261-43	Screw, machine ⊕ RF 3×6	2
67	7-623-208-21	Washer, spring 3φ	2
68	7-623-108-12	Washer 3φ	2
69	1-538-918-13	Printed Circuit Board, power supply	1
70	2-057-716	Plate, bottom	1
71	7-623-108-12	Washer 3φ	2
72	7-623-208-21	Washer, spring 3φ	2
73	7-621-261-43	Screw, machine ⊕ RF 3×6	2
74	7-623-110-02	Washer 4φ	4
75	7-621-261-73	Screw, machine ⊕ RF 3×12	2
76	2-029-953	Label, voltage indication (General Export Model only)	1
	2-030-610	Label, voltage indication (UL, CSA Model only)	1
77	1-509-015	Socket, AC outlet CNJ 902	1
78	1-536-226	Terminal Strip, speaker output	1
79	2-057-956	Cushion	1
80		Transistor 2SC 895 Q 901	1
81		Bushing (supplied with transistor)	2
82	7-623-508-01	Lug 3φ	1
83	7-623-208-21	Washer, spring 3φ	1
84	7-622-108-02	Nut 3φ	2
85	7-623-508-01	Lug 3φ	1
86	1-509-029	Connector, Rec/PB CNJ 901 (General Export Model)	1
87	1-536-179	Terminal strip C-1-L-1	1
88	2-047-211-06	Rivet	2
89	1-507-163-13	Jack, input J501~504, J601~604	2
90	1-536-180	Terminal strip C-1-L-2	1
91	1-534-487-21	Cord, power	1
92	2-043-779	Band, bar antenna support	2
93	1-401-370	Antenna L 303	1
94	7-621-261-63	Screw, machine ⊕ RF 3×10	2
95	7-623-208-21	Washer, spring 3φ	4
96	7-621-261-63	Screw, machine ⊕ RF 3×10	2
97	X-20437-13	Bracket Ass'y, bar antenna support	1
98	2-043-775	Plate, bar antenna retaining	1
99	2-047-211-07	Rivet	12
100	7-621-261-43	Screw, machine ⊕ RF 3×6	4
101	7-623-208-21	Washer, spring 3φ	4
102	2-057-715	Panel, rear	1
103	7-621-722-40	Screw, self-tapping ⊕ RF 3×6	2
104	1-518-011	Lamp, pilot PL 903	1
105	1-517-021	Socket, pilot lamp	1
106	X-20577-06	Holder Ass'y, meter support	1
107	3-807-728	Holder, stereo lamp	1
108	1-518-051	Lamp, stereo indicating	1
109	7-623-205-21	Washer, spring 2φ	1
110	7-621-255-13	Screw, machine ⊕ RF 2×3	1
111	2-056-645	Cushion, light interception	1
112	2-056-627	Knob (C), volume control	1
113	2-056-628	Knob (D), volume control	1
114	2-029-931	Knob (A), power switch	1
115	2-047-106	Mask (A)	1
116	2-057-723	Cushion (B), light interception	2
117	2-054-832	Mask (D)	3
118	2-047-107	Mask (B)	1

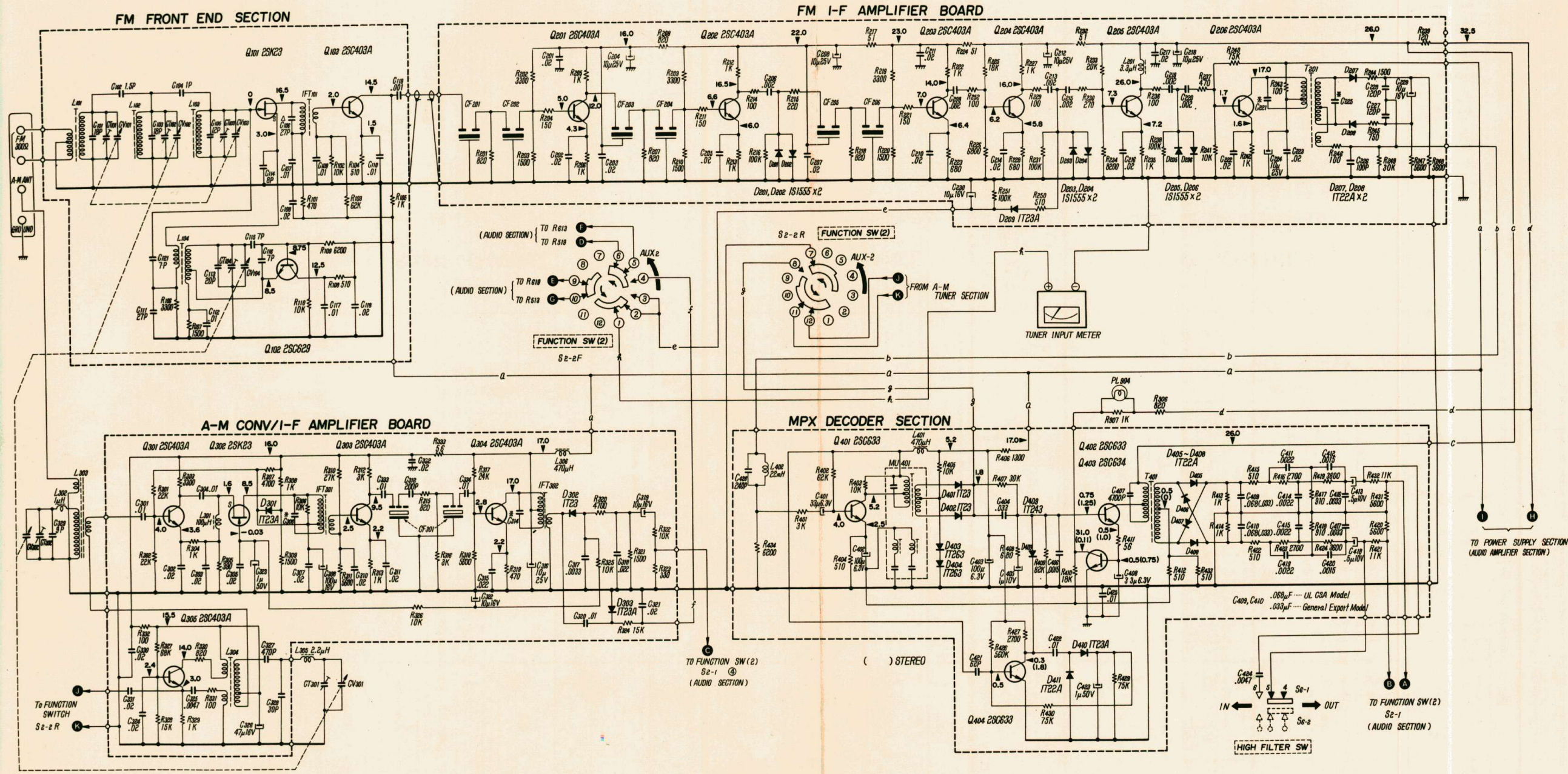

Symbol	Description	Position
S2	FUNCTION SW (2)	FM AUTO
S3	HIGH FILTER SW	OUT

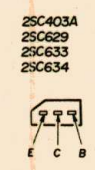
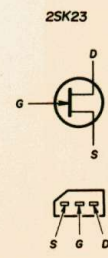
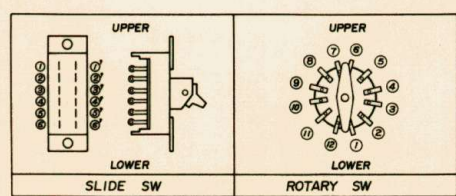

TO POWER SUPPLY SECTION
(AUDIO AMPLIFIER SECTION)

HIGH FILTER SW

() STEREO

TO FUNCTION SW (2)
S2-1 (3)
(AUDIO SECTION)

TO FUNCTION SW (2)
S2-1
(AUDIO SECTION)

L-CH

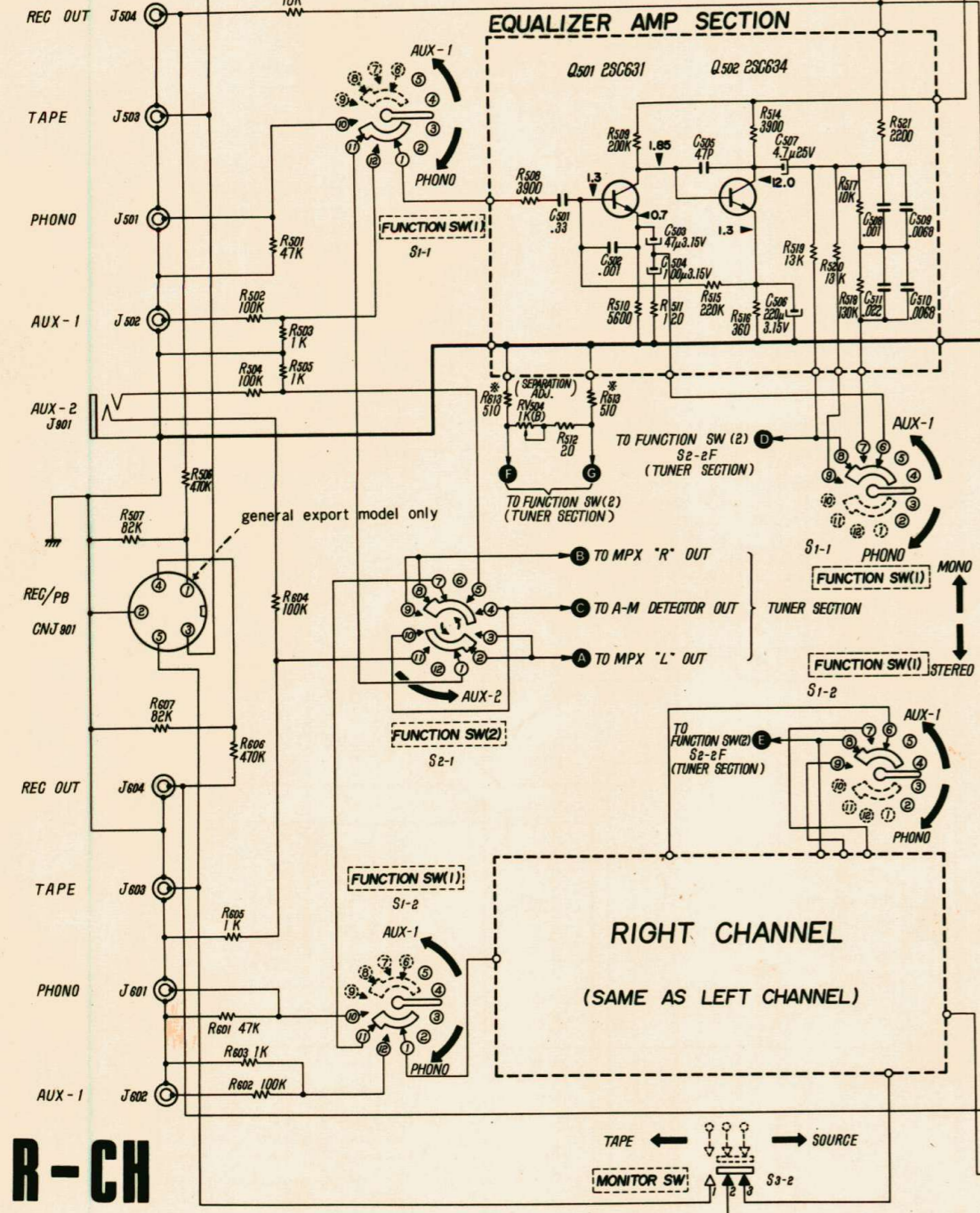

R-CH

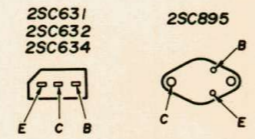
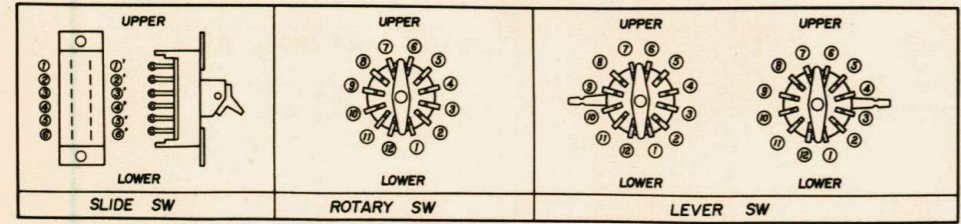
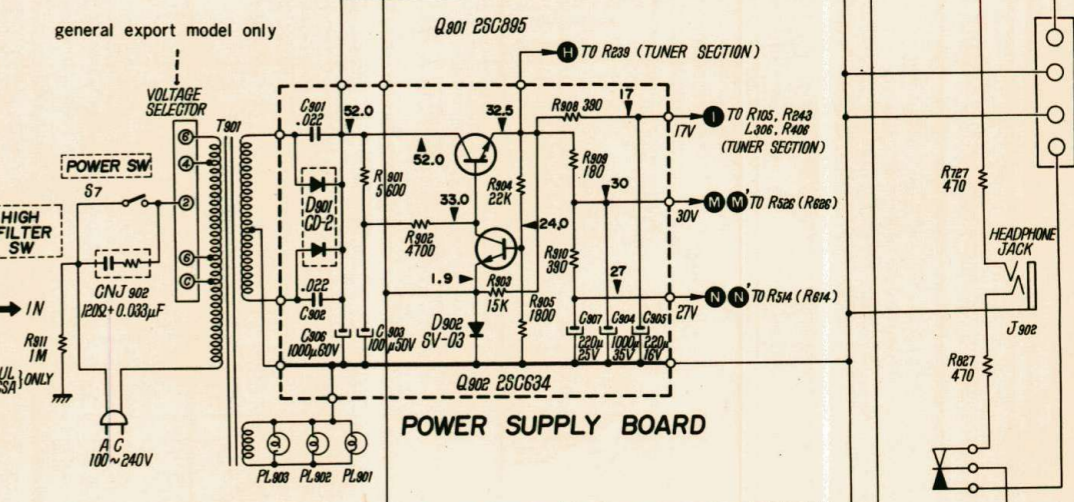
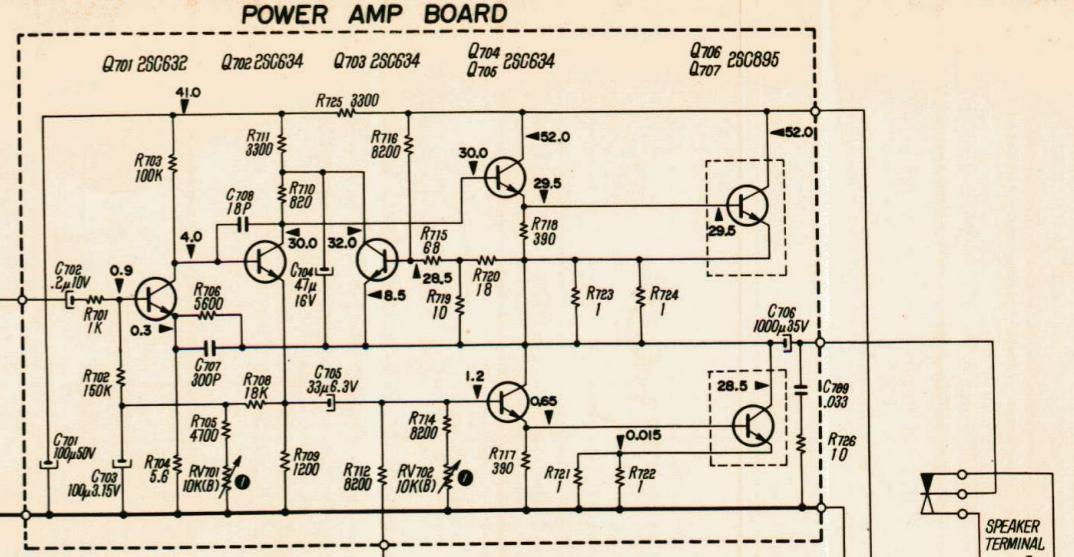
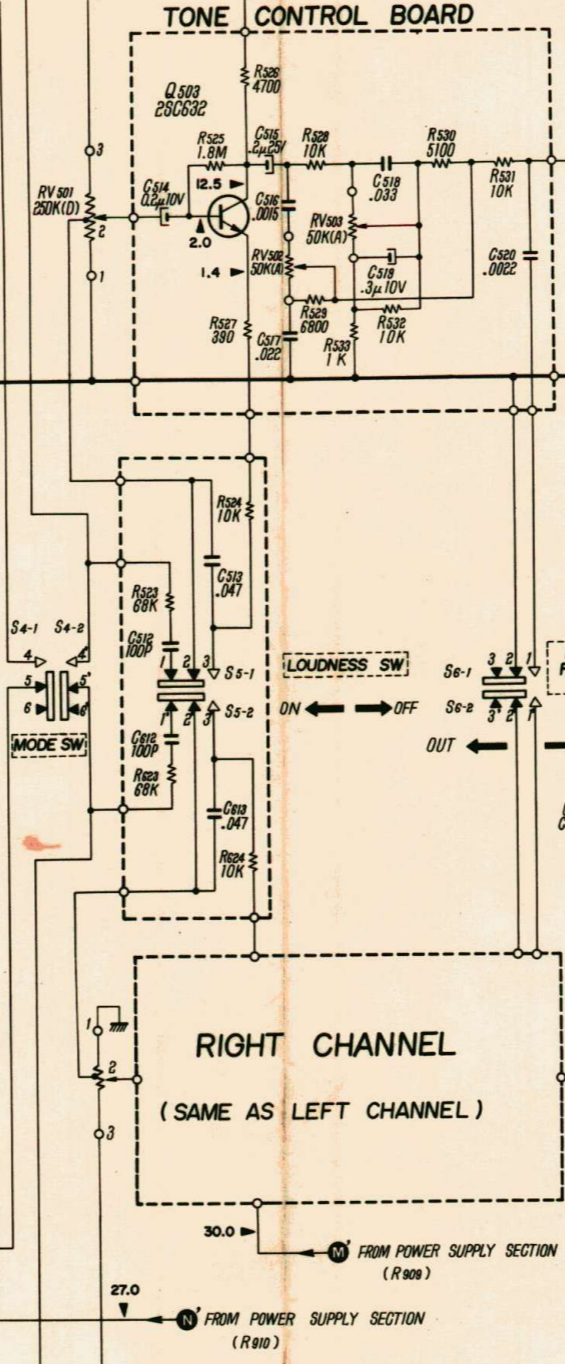

**SCHEMATIC DIAGRAM
SONY® STR-6040**

© 1969

Symbol	Description	Position
S1	FUNCTION SW (1)	FUNCTION (2)
S2	FUNCTION SW (2)	FM AUTO
S3	MONITOR SW	SOURCE
S4	MODE SW	STEREO
S5	LOUDNESS SW	ON
S6	HIGH FILTER SW	OFF
S7	POWER SW	OFF

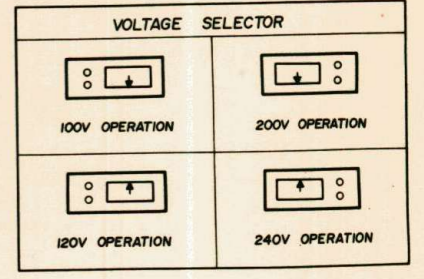

Note:
All resistance values are in ohms. K=1000, M=1000K.
All capacitance values are in μ F except as indicated with p, which means μ F.
All voltages are dc measured with a VOM (DC 20 kohms/volt) under no signal condition.
Resistors marked * should be selected.

Complete Spare Parts List for STR-6040 (E, UL, CSA)

January, 1969

Part No. DescriptionI. Mechanical PartsMain Section

X-20578-11	Chassis Ass'y (E type only) -----	1
X-20577-02	Chassis Ass'y (UL, CSA types only) -----	1
-03	Bracket (A) Ass'y, pulley support -----	1
-04	Bracket (B) Ass'y, pulley support -----	1
-05	Pointer Guide Ass'y -----	1
-06	Holder Ass'y, meter -----	1
-07	Balancer Ass'y -----	1
X-20437-13	Bracket Ass'y, antenna -----	1
2-057-711	Holder, tuning shaft -----	1
-712	Shaft, tuning -----	1
-713	Sub-panel -----	1
-714	Plate, back -----	1
-715	Panel, rear -----	1
-716	Plate, bottom -----	1
-717	Cabinet -----	1
-718	Heat Sink -----	1
-719	Drum, dial -----	1
-720	Nut (A) -----	1
-722	Rubber (A), light interception -----	2
-723	Rubber (B), light interception -----	2
-724	Holder Plate, push switch -----	1
-725	Cushion, dial scale plate -----	2
-726	Shading, light interception -----	2
-729	Shading, band -----	1
-701	Panel -----	1
-807	Spacer -----	2
-809	Plate, dial scale -----	1
-804	Label, specification (E) -----	1
3-852-802	Shading (2), light interception -----	2
2-057-956	Shading B, light interception -----	2
-967	Shading C, light interception -----	2
0-029-624	Spring -----	1
2-029-931	Knob A, lever -----	1
-932	Knob B, lever -----	1
-930	Screw, case -----	4

<u>Part No.</u>	<u>Description</u>	<u>Q'ty</u>
2-029-953	Label, voltage indicate -----	1
2-047-106	Cushion (A), light interception -----	1
-107	Cushion (B), light interception -----	1
-140	Shading, lamp -----	1
-211-07	Rivet, TA -----	12
-06	Rivet, TA -----	4
2-043-775	Bracket, antenna -----	1
-779	Band, antenna -----	2
2-051-922	Cap, knob (loudness switch) -----	1
2-054-832	Cushion (D), light interception -----	3
2-056-625	Knob (A), tuning -----	1
-626	Knob (B), function -----	3
-627	Knob (C), volume control -----	1
-628	Knob (D), volume control -----	1
-636	Nut (B) -----	1
-637	Washer -----	2
-645	Cushion, light interception -----	1
-642	Guide, lever switch -----	1
-643	Cushion, VC -----	2
3-409-124	Washer, nylon -----	2
3-410-032	Stopper, cord -----	1
0-051-263-04	Foot, rubber -----	4
3-807-728	Bracket, pilot lamp -----	1
3-811-140-00	Pulley P-10 -----	3

Front End Section

3-852-803	Plate (A), front end shield -----	1
-804	Plate (B), front end shield -----	1
2-056-635	Holder Plate, VC -----	1

Screws, Washers & Nuts

7-621-255-13	Screw, machine (+) RF 2 x 3 -----	1
-259-23	Screw, machine (+) RF 2.6 x 4 -----	1
-261-43	Screw, machine (+) RF 3 x 6 -----	46
-63	Screw, machine (+) RF 3 x 10 -----	2
-73	Screw, machine (+) RF 3 x 12 -----	10
-269-03	Screw, machine (+) RF 4 x 16 -----	4
-713-27	Set, screw 3 x 4 -----	2
-722-40	Screw, selftapping (+) RF 3 x 6 -----	28

<u>Part No.</u>	<u>Description</u>	<u>Q'ty</u>
7-621-770-25	Screw, machine (+) B 3 x 6 -----	2
7-622-108-02	Nut 3 ϕ -----	10
-130-02	" 4 ϕ -----	2
7-623-108-12	Washer 3 ϕ (Middle) -----	31
-110-02	" 4 ϕ (Small) -----	4
-205-21	" , spring 2 ϕ -----	1
-207-21	" , " 2.6 ϕ -----	1
-208-21	" , " 3 ϕ -----	41
-210-21	" , " 4 ϕ -----	6
-508-01	Lug 3 ϕ -----	6
-616-01	Eyelet 2 ϕ x 3 -----	2
7-624-109-01	Washer, retaining ring E-5 -----	1
7-623-208-22	Washer, spring 3 ϕ -----	4

Accessories & Packing Materials

3-790-802-11	Manual, instruction -----	1
4-404-717-01	Card, inspection -----	1
3-701-020-00	Bag, check sheet -----	1
-026	Label, tack -----	1
-030	Label, self -----	1
7-491-001-01	Desiccant -----	1
X-44900-02	Cloth, polishing -----	1
1-501-083-21	Antenna, ribbon -----	1
1-506-138-11	Plug, phono; red -----	1
-12	Plug, phono; white -----	1
-191-11	Plug, binaural -----	1

II. Electrical Parts

Front End Section

Y-38528-01	Completed, front end (FAF-011AW) -----	1
1-539-046-12	Printed Circuit Board, front end -----	1
	Junction Type FET 2SK23 Q101 -----	1
	Transistor 2SC403A Q103 -----	1
	" 2SC629 Q102 -----	1
1-151-191-12S	Capacitor, variable FM/AM CV101-104,301,302 --	1
1-401-371	Coil, antenna L101 -----	1
1-403-295	IFT, FM IFT101 -----	1
1-405-377	Coil, oscillator L104 -----	1

<u>Part No.</u>	<u>Description</u>	<u>Q'ty</u>
1-425-446	Coil, RF	L102,103 ----- 2
1-407-178	Inductor, micro 1 μ H	L105 ----- 1
1-536-177	Terminal Strips	L-1 ----- 1
<u>Capacitor, ceramic</u>		
1-101-937	1pF +10% 500WV	C104 ----- 1
-938	1.5pF " "	C102 ----- 1
1-102-875	7pF +5% 50WV	C115,116 ----- 2
1-101-961	12pF " "	C105 ----- 1
-862	18pF " "	C101,103,105 ----- 2
1-102-899	20pF " "	C113 ----- 1
1-101-918	0.001 μ F +80% -20% 25WV	C119 ----- 1
-072	0.01 μ F " "	C107,109,110,117 --- 4
1-102-077	0.01 μ F +20% 50WV	C112 ----- 1
1-101-073	0.02 μ F +80% -20% 25WV	C108,118 ----- 2
-869	27pF +5% 50WV	C111 ----- 1
-073	0.02 μ F +80% -20% 25WV	C120 ----- 1
-957	7pF \pm 0.5% 50WV	C121 ----- 1
-958	8pF " "	C114,122 ----- 1
<u>Resistor, carbon</u>		
1-244-665	470 Ω +5% RD1/4SR	R101 ----- 1
-666	510 Ω " "	R104,108 ----- 2
-673	1k Ω " "	R105 ----- 1
-675	1.5k Ω " "	R107 ----- 1
-685	3.3k Ω " "	R106 ----- 1
-692	6.2k Ω " "	R109 ----- 1
-697	10k Ω " "	R102,110 ----- 2
-716	62k Ω " "	R103 ----- 1
1-908-925-07	Tube 25mm 0.7 ϕ	----- 1

IF Section

1-539-029-11	Printed Circuit Board, I-F	----- 1
	Transistor 2SC403A-2	Q206 ----- 1
	" 2SC403A-3	Q201,202,203 ----- 3
	" 2SC403A-4	Q204,205 ----- 2
	Diode 1T22A	D207,208 ----- 2
	" 1T23A	D209 ----- 1
	" 1S1555	D201-206 ----- 6

<u>Part No.</u>	<u>Description</u>				<u>Q'ty</u>
1-403-291	Transformer, discriminator T201 -----				1
-297-15	Filter, ceramic CF201-206 -----				6
-11					
1-407-184	Inductor, micro 3.3 μ H L201 -----				1
<u>Capacitor, ceramic</u>					
1-101-896	100pF	+5%	50WV	C226 -----	1
-919	2000pF	+80% -20%	25WV	C206,209,213,215, 219,220 -----	6
-073	0.02 μ F	"	"	C201-203,205,207, 210,211,216,217, 222,214,223 -----	12
<u>Capacitor, styrol</u>					
1-103-603	120pF	+5%	50WV	C227,228 -----	2
<u>Capacitor, electrolytic</u>					
1-121-347	10 μ F	+100% -10%	16WV	C229,230 -----	2
-283	10 μ F	"	25WV	C204,208,212,224 ---	4
-286	33 μ F	"	"	C218 -----	1
<u>Resistor, composition</u>					
1-202-551-31	120 Ω	+10%	RC1/2	R239 -----	1
<u>Resistor, carbon</u>					
1-244-642	51 Ω	+5%	RD1/4SR	R217,224,232 -----	3
-649	100 Ω	"	"	R214,229,236,243, 246 -----	5
-653	150 Ω	"	"	R204,211,221 -----	3
-657	220 Ω	"	"	R215 -----	1
-659	270 Ω	"	"	R230 -----	1
-660	300 Ω	"	"	R250 -----	1
-665	470 Ω	"	"	R237 -----	1
-669	680 Ω	"	"	R223,228 -----	2
-670	750 Ω	"	"	R245 -----	1
-671	820 Ω	"	"	R201,207,208,218 ---	4
-673	1k Ω	+10%	"	R205,206,212,213, 222,227,235,242 ---	8

<u>Part No.</u>	<u>Description</u>	<u>Q'ty</u>
1-244-677	1.5k Ω <u>+10%</u> RD1/4SR R203,210,220,244 ---	4
-685	3.3k Ω " " R202,209,219 -----	3
-691	5.6k Ω " " R247,248 -----	2
-693	6.8k Ω " " R226 -----	1
-695	8.2k Ω " " R234 -----	1
-697	10k Ω " " R241 -----	1
-703	18k Ω " " R225 -----	1
-704	20k Ω " " R233 -----	1
-708	30k Ω " " R249 -----	1
-718	75k Ω " " R240 -----	1
-721	100k Ω " " R216,231,238,251 ---	4

AM Section

1-539-021-12	Printed Circuit Board, A-M -----	1
	Transistor 2SK23 Q302 -----	1
	" 2SC403A-2 Q305 -----	1
	" 2SC403A-3 Q303 -----	1
	" 2SC403A-4 Q301,304 -----	2
	Diode 1T23 D302 -----	1
	" 1T23A D301,303 -----	2
1-403-128	IFT, AM IFT302 -----	1
-152	" , " IFT301 -----	1
-153	Filter, ceramic 455kHz CF301 -----	1
1-405-359	Coil, MW oscillator L304 -----	1
1-407-169	Inductor, micro 100 μ H L301 -----	1
-177	" , " 470 μ H L306 -----	1
-182	" , " 2.2 μ H L305 -----	1
-178	" , " 1.0 μ H L302 -----	1

Capacitor, ceramic

1-101-874	36pF <u>+5%</u> 50WV C328 -----	1
-072	0.01 μ F <u>+80%</u> -20% 25WV C301,304,320,333,334 -----	5
-073	0.02 μ F " " C302,303,305,307,310,311,324,330,331,332,321 -----	11

Capacitor, styrol

1-103-608	200pF <u>+5%</u> 50WV C312 -----	1
-617	470pF " " C327 -----	1

<u>Part No.</u>	<u>Description</u>				<u>Q'ty</u>
<u>Capacitor, mylar</u>					
1-105-827	0.0033 μ F	+20%	50WV	C317 -----	1
-829	0.0047 μ F	"	"	C325 -----	1
-837	0.022 μ F	"	"	C315,318 -----	2
<u>Capacitor, electrolytic</u>					
1-121-343	1 μ F	+150% -10%	50WV	C323 -----	1
-347	10 μ F	+100% -10%	16WV	C319,322 -----	2
-283	10 μ F	"	25WV	C316 -----	1
-353	47 μ F	"	16WV	C326 -----	1
-356	100 μ F	"	"	C308 -----	1
<u>Resistor, carbon</u>					
1-244-649	100 Ω	+5%	RD1/4SR	R331,332 -----	2
-665	470 Ω	"	"	R319 -----	1
-671	820 Ω	"	"	R315,330 -----	2
-673	1k Ω	"	"	R304,313,308,329 ---	4
-677	1.5k Ω	"	"	R309,321 -----	2
-684	3k Ω	"	"	R312,316 -----	2
-685	3.3k Ω	"	"	R303 -----	1
-689	4.7k Ω	"	"	R307,320 -----	2
-691	5.6k Ω	"	"	R311,318 -----	2
-697	10k Ω	"	"	R306,325,326,322 ---	4
-701	15k Ω	"	"	R324,328 -----	2
-705	22k Ω	"	"	R301,302 -----	2
-706	24k Ω	"	"	R317 -----	1
-707	27k Ω	"	"	R310 -----	1
-717	68k Ω	"	"	R327 -----	1
-643	56 Ω	"	"	R333 -----	1
-663	390 Ω	"	"	R305 -----	1
-669	680 Ω	"	"	R323 -----	1

MPX, EQ Section

1-539-023-11	Printed Circuit Board, MPX, EQ -----			1
	Transistor	2SC631-7	Q501,601 -----	2
	"	2SC633-6	Q401,402 -----	2
	"	2SC633-7	Q404 -----	1
	"	2SC634-6	Q403 -----	1
	"	2SC634-7	Q502,602 -----	2

<u>Part No.</u>	<u>Description</u>	<u>Q'ty</u>
	Diode 1T243	D409 ----- 1
	" 1T263	D403,404 ----- 2
	" 1T22A	D405-408 ----- 4
	" 1T23	D401,402 ----- 2
	" 1T23A	D410,411 ----- 1
1-221-964	Resistor, adjustable 1k Ω (B)	RV504 ----- 1
1-407-177	Inductor, micro 470 μ H	L401 ----- 1
1-409-169	Coil, encased	MU401 ----- 1
1-425-260	Transformer, switching 38kHz	T401 ----- 1
<u>Capacitor, styrol</u>		
1-103-575	4700pF <u>+5%</u> 50WV	C407 ----- 1
<u>Capacitor, ceramic</u>		
1-101-072	0.01 μ F +80% -20% 25WV	C422,425 ----- 2
-872	33pF <u>+5%</u> 50WV	C421 ----- 1
<u>Capacitor, mylar</u>		
1-105-661	0.001 μ F <u>+10%</u> 50WV	C502,602,508,608 --- 4
-663	0.0015 μ F " "	C406,412,420 ----- 3
-665	0.0022 μ F " "	C411,414,415,419 --- 4
-667	0.0033 μ F " "	C416,417 ----- 2
-669	0.0047 μ F " "	C424 ----- 1
-671	0.0068 μ F " "	C509,609,510,610 --- 4
-677	0.022 μ F " "	C511,611 ----- 2
-414	0.033 μ F " 35WV	C404 ----- 1
-416	0.068 μ F " "	C409,410 ----- 2
-420	0.33 μ F " "	C501,601 ----- 2
<u>Capacitor, silvered mica</u>		
1-107-123	47pF <u>+10%</u> 50WV	C505,605 ----- 2
<u>Capacitor, electrolytic</u>		
1-121-281	4.7 μ F +100% -10% 25WV	C507,607 ----- 2
-343	1 μ F +150% -10% 50WV	C423 ----- 1
-284	33 μ F +100% -10% 6.3WV	C401,408 ----- 2
-294	220 μ F " 3.15WV	C506,606 ----- 2
-290	100 μ F " 3.6WV	C504,604 ----- 2

<u>Part No.</u>	<u>Description</u>	<u>Q'ty</u>
1-121-291	100 μ F +100% -10% 6.3WV C402 -----	1
-356	100 μ F " 16WV C403 -----	1
-287	47 μ F " 3.15WV C503,603 -----	2

Capacitor, aluminum electrolytic

1-127-022	0.5 μ F +20% 10WV C413,418 -----	2
-023	1 μ F " " C405 -----	1

Resistor, carbon

1-244-632	20 Ω +5% RD1/4SR R512 -----	1
-651	120 Ω " " R511,611 -----	2
-643	56 Ω " " R411 -----	1
-662	360 Ω " " R516,616 -----	2
-666	510 Ω " " R404,412,415,422 ---	4
-669	680 Ω " " R408 -----	1
-672	910 Ω " " R417,418 -----	2
-673	1k Ω " " R413,414 -----	2
-676	1.3k Ω " " R406 -----	1
-681	2.2k Ω " " R521,621 -----	2
-683	2.7k Ω " " R416,423,427 -----	3
-686	3.6k Ω " " R419,424 -----	2
-687	3.9k Ω " " R508,608,514,614 ---	4
-703	18k Ω " " R410 -----	1
-691	5.6k Ω " " R420,431,510,610 ---	4
-697	10k Ω " " R403,405,517,522, 617,622 -----	6
-698	11k Ω " " R421,432 -----	2
-700	13k Ω " " R520,620,519,619 ---	4
-708	30k Ω " " R407 -----	1
-716	62k Ω " " R402 -----	1
-718	75k Ω " " R429,430 -----	2
-714	51k Ω " " R409 -----	1
-724	130k Ω " " R518,618 -----	2
-728	200k Ω " " R509,609 -----	2
-729	220k Ω " " R515,615 -----	2
-739	560k Ω " " R426 -----	1
-666	510k Ω " " R433 -----	1
-684	3k Ω " " R401 -----	1
-666	510 Ω " " R513,613 (Adjust) ---	2
-673	1k Ω " " R513,613 (") ---	
-677	1.5k Ω " " R513,613 (") ---	
-680	2k Ω " " R513,613 (") ---	

<u>Part No.</u>	<u>Description</u>				<u>Q'ty</u>
	<u>Resistor, adjustable</u>				
1-221-967	10k Ω (B)			RV701,801,702,802 --	4
	<u>Capacitor, mylar</u>				
1-105-821	0.001 μ F	+20%	50WV	C710,810 -----	2
-839	0.033 μ F	"	"	C709,809 -----	2
	<u>Capacitor, silvered mica</u>				
1-107-113	18pF	+10%	50WV	C708,808 -----	2
-131	100pF	"	"	C707,807 -----	2
	<u>Capacitor, electrolytic</u>				
1-121-284	33 μ F	+100% -10%	6.3WV	C705,805 -----	2
-353	47 μ F	"	16WV	C704,804 -----	2
-290	100 μ F	"	3.6WV	C703,803 -----	2
-384	100 μ F	"	50WV	C701,801 -----	2
-388	1000 μ F	+150% -10%	35WV	C706,806 -----	2
	<u>Capacitor, aluminum electrolytic</u>				
1-127-072	0.2 μ F	+80% -20%	10WV	C702,802 -----	2
	<u>Resistor, composition</u>				
1-202-525-51	10 Ω	+20%	RC1/2	R726,826 -----	2
	<u>Resistor, carbon</u>				
1-244-601	1 Ω	+5%	RD1/4SR	R721,821,722,822, 723,823,724,824 ---	8
-625	10 Ω	"	"	R719,819 -----	2
-643	56 Ω	"	"	R704,804 -----	2
-661	330 Ω	"	"	R701,801 -----	2
-663	390 Ω	"	"	R717,817,718,818 ---	4
-671	820 Ω	"	"	R710,810 -----	2
-675	1.2k Ω	"	"	R709,809 -----	2
-685	3.3k Ω	"	"	R711,811 -----	2
-689	4.7k Ω	"	"	R705,805 -----	2
-691	5.6k Ω	"	"	R706,806 -----	2

<u>Part No.</u>	<u>Description</u>	<u>Q'ty</u>
1-244-695	8.2k Ω +5% RD1/4SR R712,812,714,814, 716,816 -----	6
-703	18k Ω " " R708,808 -----	2
-721	100k Ω " " R703,803 -----	2
-725	150k Ω " " R702,802 -----	2
-631	18 Ω " " R720,820 -----	2
-645	68 Ω " " R715,815 -----	2
-685	3.3k Ω " " R725,825 -----	2

Power Supply Section

1-538-918-13	Printed Circuit Board, power supply -----	1
	Transistor 2SC634 Q902 -----	1
	Diode SV-03 D902 -----	1
	" CD-2 D901 -----	1

Capacitor, mylar

1-105-917	0.022 μ F +20% 200WV C901,902 -----	2
-----------	---	---

Capacitor, electrolytic

1-121-384	100 μ F +100% -10% 50WV C903 -----	1
-358	220 μ F " " 16WV C905 -----	1
-297	220 μ F " " 25WV C907 -----	1
-388	1000 μ F +150% -10% 35WV C904 -----	1

Resistor, carbon

1-209-222	820 Ω +5% RD1SP R906 -----	1
1-210-602	390 Ω " RD2SP R908 -----	1
1-242-655	180 Ω " RD1/4UR R909 -----	1
-663	390 Ω " " R910 -----	1
-673	1k Ω " " R907 -----	1
-679	1.8k Ω " " R905 -----	1
-689	4.7k Ω " " R902 -----	1
-691	5.6k Ω " " R901 -----	1
-701	15k Ω " " R903 -----	1
-705	22k Ω " " R904 -----	1

General Items

Transistor 2SC895	Q706,806,709,809 ---	4
-------------------	----------------------	---

<u>Part No.</u>	<u>Description</u>	<u>Q'ty</u>
	Transistor 2SC895	Q901 ----- 1
1-222-201	Resistor, variable 250k Ω (D)	RV501,601 ----- 1
1-401-370	Antenna, bar	L303 ----- 1
1-441-453-13S	Transformer, power	T901 ----- 1
1-507-163-13	Jack, 4P-in	J501-504,601-604 --- 2
-265-12	JM-60, M-3T Jack	J901 ----- 1
-267	JM-60, M-3TS Jack	J902 ----- 1
1-509-015	Socket, AC	CNJ902 ----- 1
-029	Connector, Rec./P.B.	CNJ901 ----- 1
1-513-149	Switch, push	S5 ----- 1
1-514-338	Lever Switch, rotary	S1 ----- 1
-466	" " , slide	S6 ----- 1
-505	" " , seesaw	S7 ----- 1
-521	" " , slide	S4 ----- 1
-337	" " , slide	S3 ----- 1
-506	Lever, rotary	S2 ----- 1
1-517-021	Socket, pilot lamp	----- 1
-041	Holder, lamp	----- 2
1-518-011	Lamp, pilot	PL903 ----- 1
-051	Lamp, stereo	PL904 ----- 1
-070	Lamp, pilot	PL901,902 ----- 2
1-520-083	Meter, tuning	M901 ----- 1
1-536-182	Terminal Strips	2-L-2 ----- 1
1-526-165	Socket, voltage selector	----- 1
1-534-487-21	Cord, power	----- 1
1-536-144	Terminal Strips	1-L ----- 1
-179	" " C-1-L-1	----- 2
-226	Terminal Board, 4P-in	J903,904 ----- 2
-180	Terminal Strips	C-1-L-2 ----- 1
1-231-057	Encapsulated Component	0.033 μ F+120 Ω 50WV CP901- 1
1-105-681	Capacitor, mylar	0.047 μ F +10% 50WV C513,613 --- 2
1-107-085	Capacitor, silvered mica	100pF +5% 50WV C512, 612 ----- 2
1-121-330	Capacitor, electrolytic	1000 μ F +100% -10% 60WV C906 ----- 1
1-202-565	Resistor, composition	470 Ω +10% RC1/2 R727,827- 2
	<u>Resistor, carbon</u>	
1-244-673	1k Ω +5% RD1/4SR	R503,603,505,605 --- 4
-697	10k Ω " "	R524,624 ----- 2
-713	47k Ω " "	R501,601 ----- 2
-717	68k Ω " "	R523,623 ----- 2

<u>Part No.</u>	<u>Description</u>	<u>Q'ty</u>
1-244-719	82k Ω <u>+5%</u> RD1/4SR R507,607 -----	2
-721	100k Ω " " R502,602,504,604 ---	4
-737	470k Ω " " R506,606 -----	2
7-633-120-42	String, dial -----	1500mm

Mounted Circuit Board

X-20577-21	Tone Control -----	1
-22	Power Supply -----	1
-23	Power Amplifier -----	1
-24	MPX, equalizer -----	1
-25	IF -----	1
-26	Amplifier -----	1

* Additional Parts List for UL Model

2-057-803	Label, specification UL -----	1
2-029-955	Label, outlet -----	1
2-030-610	Sheet D, input indicate -----	1
3-422-204-04	Label (B), caution -----	1
3-811-819-03	Label, FCC -----	1
3-709-802-21	Manual, instruction -----	1
3-994-399	Card, warranty -----	1
3-701-026	Label, tack -----	2
2-057-728	Carton -----	1
-806	Master Carton (for two sets) -----	1/2
2-029-944	Cushion, styroform -----	2
2-047-103	Bag, polyethylene -----	1
1-441-454	Transformer, power -----	1
1-534-538-21	Cord, power -----	1

* Additional Parts List for CSA Model

2-057-805	Label, specification CSA -----	1
2-029-966	Label, AC outlet -----	1
3-790-802-41	Manual, instruction -----	1
3-793-105	Station List, warranty -----	1
-107	Card, warranty -----	1
3-701-041	Label, CSA -----	1
1-202-645	Resistor, composition 1M Ω <u>+10%</u> RC1/2 -----	1